



ADEGIS

We care a lot.

We secure the continuity of production

ADEGIS is a Polish company providing services that are designed to support Purchasing and Maintenance Departments in their daily work. We specialise in the sale and repair of industrial automation and we also implement modern systems for the acquisition and analysis of data from machines and production lines.

We have been operating continuously since 2010

Until a dozen years ago, we were a local micro-enterprise trading in industrial automation. Today, **we employ more than 50 people**, we work with industry leaders from Western Europe and we serve thousands of customers in Poland and abroad.

Our story is one of sustainability, which we also want to make possible for our customers - regardless of the sector and size of their company.



Offer built on real needs

01 Guaranteed response time

Maximum 24 hours

02 Min. 24 months warranty

For all equipment covered by service contract

03 Costs reduction

Lower purchase costs thanks to an option of an exchange service

04 Quality and safety

Extensive technical facilities and the iron rule „no repair - no costs”

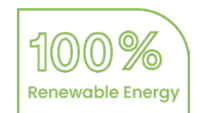



One supplier, entire industrial automation

Our online platform shop.adegis.com offers parts from leading manufacturers of industrial automation.

Through the shop, customers have access to up-to-date stocks and can significantly speed up the order process.



Scan the QR code
and visit our shop
shop.adegis.com

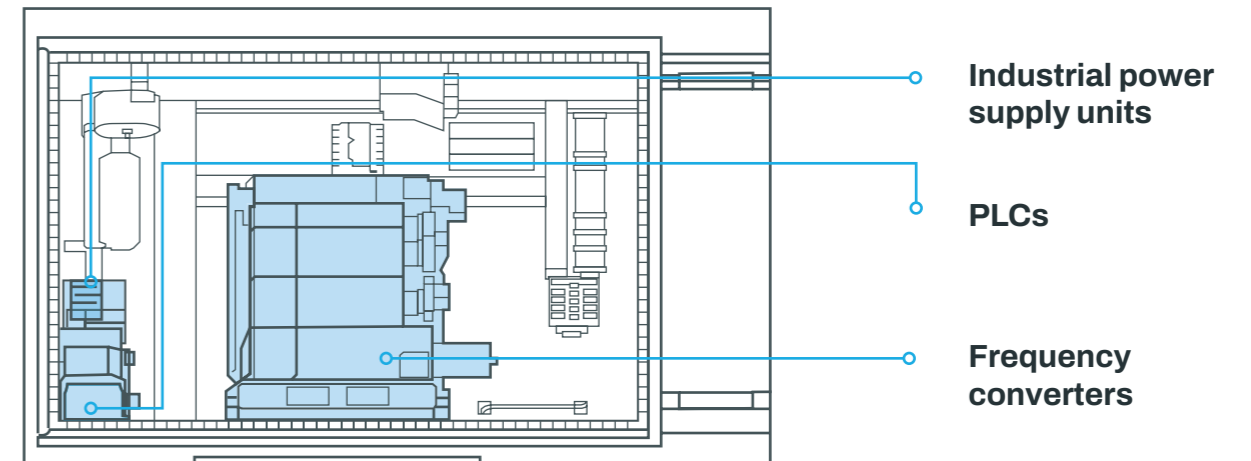
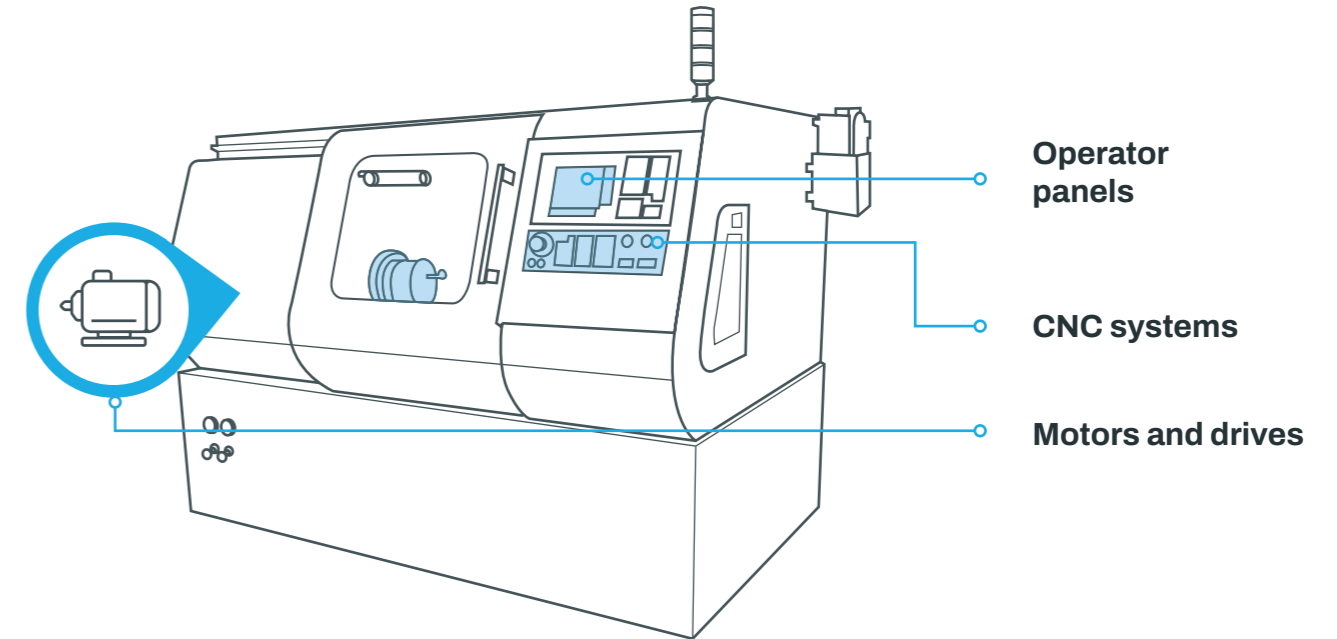

Reactive actions

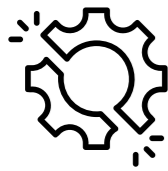

PROBLEM

Nonfunctional device

SOLUTION



Purchase

- 60,000 products on offer.
- 2-year warranty for all products.
- Saving through **exchange service**: possibility of purchasing of a device with the return of the damaged one.

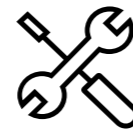

Repair

- Free diagnostics.
- No repair = no costs.
- 2-year guarantee on the entire device - regardless of the scope of the repair.

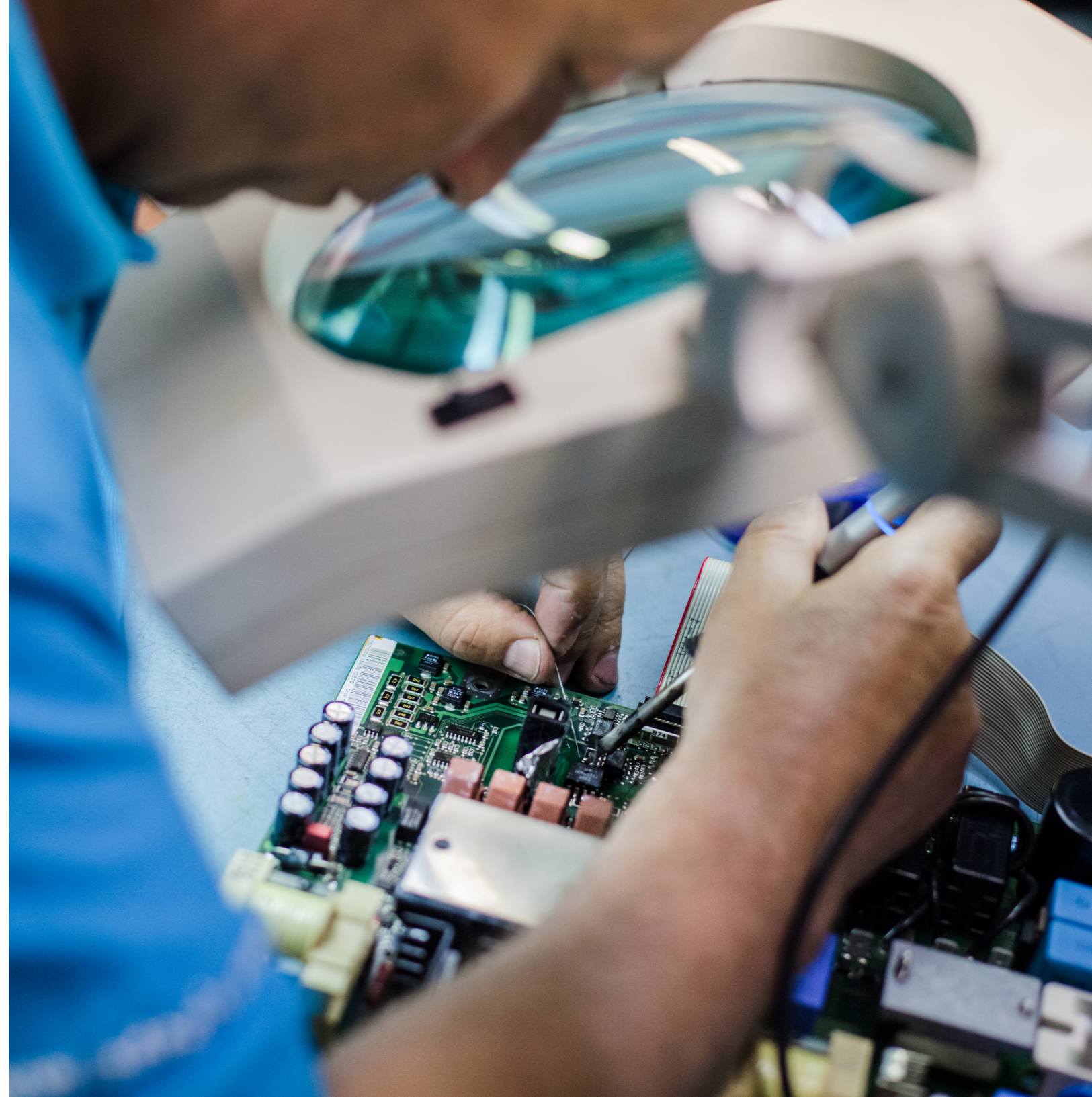

Preventive actions



PROBLEM

**Long
downtime**

SOLUTION



**Dedicated
stock**

- **Stock** with spare parts in ADEGIS.
- **Immediate access** to key components.
- **Low-cost** service.



PROBLEM

**Frequent
failures**

SOLUTION



**Service
contract**

- **Subscription** to ADEGIS servicing and repair.
- **Lifetime guarantee.**
- **Flexible** contract terms.
- Guaranteed response time: **max. 24 h.**



24/7 process monitoring with the iba system

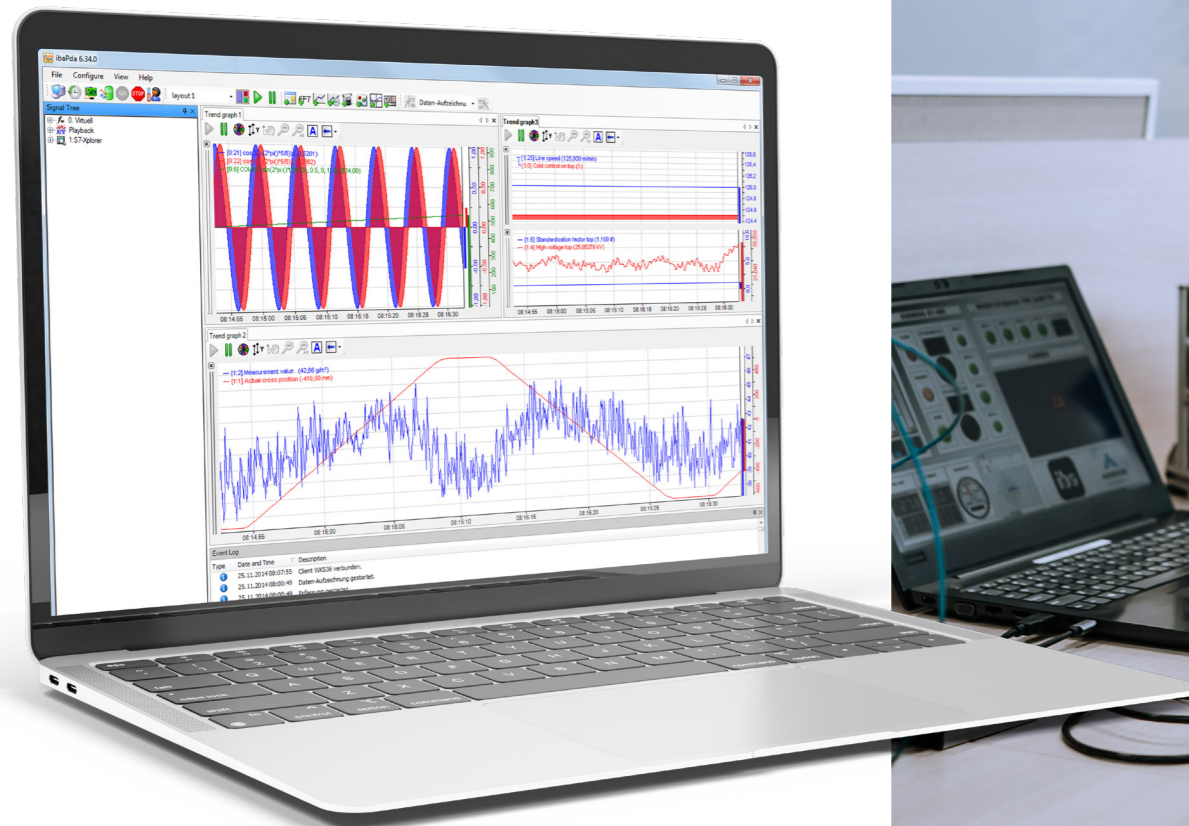

The iba software has proven itself over the years as one of the most versatile data acquisition and analysis systems necessary for maintenance and production.

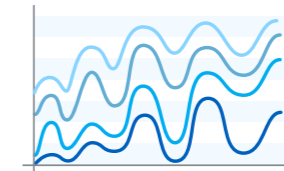

Signals from PLC

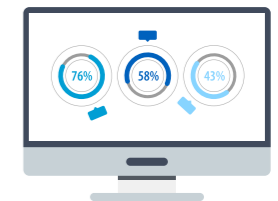

CCTV images

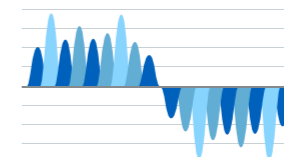

Vibration of machines and motors

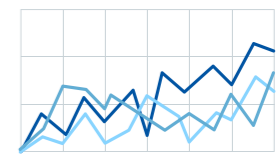

Wear of mechanical components

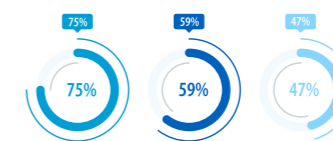

Electric power quality

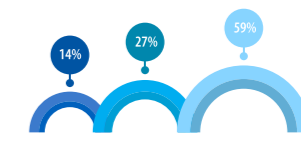

Key performance indicators



Quick reaction at the time of a crisis

Our Customer Service places importance on direct contact and individual approach to every problem.

Contact your dedicated Regional Representative to discuss the most favourable solutions for your company.

Emergency telephone number:

 **+48 884 737 947**



We can speak to you in:

1 English
tel. +48 32 440 22 10

2 Spanish
tel. +48 530 155 752

3 Czech
tel. +48 530 555 446



Electronic workshop



Electro-mechanical workshop

Research and Development Department





Sale: shop.adegis.com
iba system: iba.adegis.com
Full offer: adegis.com/en/pages/services

office@adegis.com
phone no.: +48 32 440 22 10