

# SIEMENS

## SITRANS

Pressure transmitter  
SITRANS P, Z series for gauge and  
absolute pressure

7MF1564

Operating Instructions

<u>Introduction</u>	<b>1</b>
<u>Safety instructions</u>	<b>2</b>
<u>Description</u>	<b>3</b>
<u>Assembly and connection</u>	<b>4</b>
<u>Technical data</u>	<b>5</b>
<u>Dimensional drawings</u>	<b>6</b>

## Safety Guidelines

This manual contains notices you have to observe in order to ensure your personal safety, as well as to prevent damage to property. The notices referring to your personal safety are highlighted in the manual by a safety alert symbol, notices referring only to property damage have no safety alert symbol. These notices shown below are graded according to the degree of danger.



---

### Danger

indicates that death or severe personal injury **will** result if proper precautions are not taken.

---



---

### Warning

indicates that death or severe personal injury **may** result if proper precautions are not taken.

---



---

### Caution

with a safety alert symbol, indicates that minor personal injury can result if proper precautions are not taken.

---

---

### Caution

without a safety alert symbol, indicates that property damage can result if proper precautions are not taken.

---

---

### Notice

indicates that an unintended result or situation can occur if the corresponding information is not taken into account.

---

If more than one degree of danger is present, the warning notice representing the highest degree of danger will be used. A notice warning of injury to persons with a safety alert symbol may also include a warning relating to property damage.

## Qualified Personnel

The device/system may only be set up and used in conjunction with this documentation. Commissioning and operation of a device/system may only be performed by **qualified personnel**. Within the context of the safety notes in this documentation qualified persons are defined as persons who are authorized to commission, ground and label devices, systems and circuits in accordance with established safety practices and standards.

## Prescribed Usage

Note the following:



---

### Warning

This device may only be used for the applications described in the catalog or the technical description and only in connection with devices or components from other manufacturers which have been approved or recommended by Siemens. Correct, reliable operation of the product requires proper transport, storage, positioning and assembly as well as careful operation and maintenance.

---

## Trademarks

All names identified by ® are registered trademarks of the Siemens AG. The remaining trademarks in this publication may be trademarks whose use by third parties for their own purposes could violate the rights of the owner.

## Disclaimer of Liability

We have reviewed the contents of this publication to ensure consistency with the hardware and software described. Since variance cannot be precluded entirely, we cannot guarantee full consistency. However, the information in this publication is reviewed regularly and any necessary corrections are included in subsequent editions.

# Table of contents

<b>1</b>	<b>Introduction</b> .....	<b>1-1</b>
1.1	Purpose of this documentation .....	1-1
1.2	History .....	1-1
1.3	Additional information .....	1-1
<b>2</b>	<b>Safety instructions</b> .....	<b>2-1</b>
2.1	General information .....	2-1
2.2	Correct usage.....	2-1
2.3	Laws and directives .....	2-1
2.4	Measures .....	2-2
2.5	Qualified Personnel.....	2-2
<b>3</b>	<b>Description</b> .....	<b>3-1</b>
3.1	Applications.....	3-1
3.2	Structure.....	3-1
3.3	How It works.....	3-2
<b>4</b>	<b>Assembly and connection</b> .....	<b>4-1</b>
4.1	Safety information for installation.....	4-1
4.2	Connection safety information .....	4-2
4.3	Connecting the transmitter.....	4-3
<b>5</b>	<b>Technical data</b> .....	<b>5-1</b>
5.1	SITRANS P pressure transmitter, Z series for gauge and absolute pressure.....	5-1
<b>6</b>	<b>Dimensional drawings</b> .....	<b>6-1</b>
6.1	SITRANS P, Z series gauge pressure/absolute pressure .....	6-1



# Introduction

## 1.1 Purpose of this documentation

These instructions contain all the information you need for commissioning and using the transmitter.

It is aimed both at persons mechanically installing the device, connecting it electronically, configuring the parameters and commissioning it as well as service and maintenance engineers.

## 1.2 History

The following table shows the most important changes in the documentation compared to each previous edition.

Edition	Remarks
01 10/2005	First edition
02 12/2005	The most important changes are as follows: <ul style="list-style-type: none"> <li>• Legend to figure "Connecting with voltage output" changed.</li> <li>• Chapter "Technical data"</li> </ul>

## 1.3 Additional information

### Information

The contents of these instructions shall not become part of or modify any prior or existing agreement, commitment or legal relationship. All commitments on the part of Siemens AG are contained in the respective sales contract, which also contains the complete and solely applicable warranty conditions. Any statements contained herein do not create new warranties or modify the existing warranty.

The content reflects the technical status at the time of printing. We reserve the right to make technical changes in the course of further development.

## **References**

If there are references to further information on an aspect described here, these will always be found at the end of a chapter under "See also"

## **Offices**

If you need more information or have particular problems which are not covered sufficiently by the operating instructions, contact your local Siemens office. You will find your local Siemens office on the Internet under:

[www.siemens.com/processinstrumentation](http://www.siemens.com/processinstrumentation)

Click on "Contact" and select your closest town.

## **Product information on the Internet**

The instructions are available on the Internet at:

[www.siemens.com/sitransp](http://www.siemens.com/sitransp)

Click on "More Info" and "-> Instructions and Manuals".

## Safety instructions

### 2.1 General information

This device left the factory free from safety problems. In order to maintain this status and to ensure safe operation of the device, please observe the safety information and warnings contained in these instructions.

### 2.2 Correct usage

The device may only be used for the purposes specified in these instructions.

Insofar as they are not expressly stated in these instructions, all changes to the device are the sole responsibility of the user.

### 2.3 Laws and directives

The regulations of the test certification valid in your country are to be observed.

#### **Electrical connection in hazardous areas with explosive atmospheres**

The national directives and laws for hazardous areas valid in your country must be observed for electrical connection. For example, in Germany these are:

- Operational safety regulations
- Directive for the installation of electrical systems in hazardous areas DIN EN 60079-14 (previously VDE 0165, T1)

## 2.4 Measures

For the sake of safety, the following precautions must be observed:



---

### Warning

#### "Intrinsically safe" protection type

"Intrinsically-safe" devices lose their certification as soon as they are operated on circuits which do not correspond with the test certification valid in their country.

#### Exposure to aggressive and hazardous media

The device can be operated both at high pressure and with aggressive and hazardous media. Therefore, improper use of this device may lead to serious injury and or considerable damage to property. Above all, it must be noted when the device was in use and when is to be exchanged.

---



---

### Caution

#### Electrostatic Sensitive Devices (ESD)

This device contains electrostatic sensitive devices. Electrostatic sensitive devices may be destroyed by voltages and energies that are undetectable to a human. Voltages of this kind occur as soon as a component or an assembly is touched by a person who is not grounded against static electricity. The damage to a module as a result of overvoltage cannot usually be detected immediately. It may only become apparent after a long period of operation.

---

## 2.5 Qualified Personnel

"Qualified personnel" means those who are familiar with the installation, mounting, commissioning and operation of the product. They must have the following, appropriate qualifications for their activities:

- Training or instruction/authorization in operating and maintaining devices and systems according to the safety regulations for electrical circuits, high pressures and aggressive as well as hazardous media.
- For explosion-proof devices: Training or instruction/authorization in carrying out work on electrical circuits for hazardous systems.
- Training and instruction in maintenance and use of adequate safety equipment according to safety regulations.
- Should be trained in first aid.



## Description

### 3.1 Applications

The pressure transmitter measures gauge and absolute pressures of liquids and gases.

### 3.2 Structure

#### Overview

The design of the pressure transmitter depends on the measuring span.

#### Construction for a measuring span from < 1 bar (<14.5 psi)

- Stainless steel housing with piezo-resistive silicon measuring cell (with stainless steel diaphragm, temperature-compensated) and electronics module
- Stainless steel process connection in a variety of versions.
- Electrical connection via DIN 43650 connector with M16 x 1.5, ½-14 NPT cable entry, or round M12 plug.

The pressure transmitter with a span from 1 bar (< 14.5 psi) is available with a current output of 4 to 20 mA and optionally with or without explosion protection.

#### Construction for a measuring span from ≥ 1 bar (≥14.5 psi)

- Stainless steel housing with a ceramic measuring cell and electronics module. The temperature-compensated ceramic measuring cell has a thin-film strain gauge which is mounted on a ceramic diaphragm. The ceramic diaphragm can also be used for aggressive media.
- Stainless steel process connection in a variety of versions.
- Electrical connection via DIN 43650 connector with M16 x 1.5, ½-14 NPT cable entry, or round M12 plug.

The pressure transmitter with a measuring span from ≥ 1 bar (≥ 14.5 psi) is available:

- With an output current of 4 to 20 mA optionally with or without explosion protection.
- With an output voltage of 0 to 10 V only without explosion protection.

### 3.3 How It works

#### Description

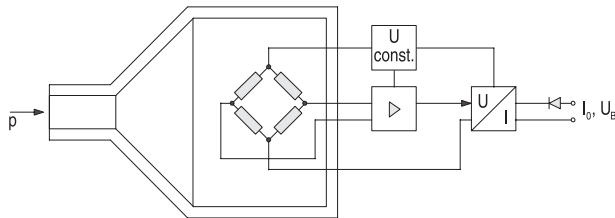

Figure 3-1 Principle of operation (two-wire technology)

- $I_0$  Output current
- $U_B$  Auxiliary power

The way a pressure transmitter works depends on the measuring span and on the type of output signal.

#### Operating principle for a measuring span from < 1 bar (<14.5 psi)

The silicon measuring cell of the pressure transmitter has a piezo-resistive resistor bridge on which the operating pressure  $p$  is transmitted through silicone oil and a stainless steel diaphragm.

The measuring cell output voltage is fed to an amplifier and converted into an output current 4 to 20 mA. The output current is linearly proportional to the input pressure. For this measuring span there is no output voltage.

#### Principle of operation for a measuring span from $\geq 1$ bar ( $\geq 14.5$ psi)

The thin-film measuring cell has a thin-film resistance bridge onto which the operating pressure  $p$  is transmitted through a ceramic diaphragm.

The voltage output from the measuring cell is fed to an amplifier and converted into an output current of 4 to 20 mA or an output voltage of DC 0 to 10 V. The output current or voltage are linearly proportional to the input pressure.

## Assembly and connection

### 4.1 Safety information for installation

#### Requirement

The transmitter can be installed for different areas of use.

Depending on the area of application and the system configuration, there may be differences in the installation.

The location of the equipment has no influence on the precision of the measurement.



#### Warning

##### Protection against incorrect use of the measuring device

Take particular care to ensure that the selected materials for the wetted parts are suitable for the process media used.

Failure to observe this precaution may result in a risk of severe personal injury and pollution of the environment.

---



#### Caution

If the surface temperatures are  $> 70^{\circ}\text{C}$ , shock protection is required.

The shock protection must be designed in such a way that, if there is a buildup of heat, the maximum permitted ambient temperature at the device is not exceeded.

The permissible ambient temperature can be found in the Technical Data.

---

#### Caution

The device may only be used within the measuring span, overload pressure limits and voltage limits dependent on the protection type specified on the rating plate.

---

**Notice**

External loads may not be allowed to affect the transmitter as this may result in an incorrect measured value or even destruction of the device. In the worst case scenario, the process medium will escape.

---



**Warning**

**"Intrinsically-safe" protection type**

Notes on operating the intrinsically safe type in areas where there is a risk of explosion:

Operation is only permissible in certified intrinsically-safe circuits. The transmitter corresponds to category 1/2.

The EC type approval certificate applies to installation of the device in the walls of containers and pipes in which explosive gas/air or vapor/air mixtures occur only under atmospheric conditions. Atmospheric conditions apply for a pressure of 0.8 to 1.1 bar (11.6 to 16 psi) and a temperature of -20 °C to +60 °C (-4 to +140 °F). The permissible span of environmental temperatures ( $T_a$ ) is -25 °C to +85 °C (-13 °F to +185 °F). The permissible medium temperature  $T_M$  depends on the application:

- Category 1 :  $T_M$  is -20 °C to +60 °C (-4 °F to +140 °F) (II 1/2 G EEx ia IIC T4)
- Category 2 :  $T_M$  is -30 °C to +120 °C (-22 °F to +248 °F) (II 2 G EEx ib IIC T4)

The operator may use the device under non-atmospheric conditions outside the limits specified in the EC type examination certificate (or the certification applicable in the country of use) at the operator's own risk if safety measures which may be necessary in accordance with use conditions (explosive mixture) have been taken. The limit values specified in the general Technical Data are to be complied with in all cases.

---

## 4.2 Connection safety information

### Requirement



**Warning**

**Fixed installation**

Devices to be operated in hazardous areas should be connected with fixed cable installation.

---



### Warning

Observe the provisions of the test certification valid for your country.

#### Electrical connection in hazardous areas with explosive atmospheres

The national directives and laws for hazardous areas valid in your country must be observed for electrical connection.

In Germany these are, for example:

- Operational safety regulations
- Directive for the installation of electrical systems in hazardous areas DIN EN 60079-14 (previously VDE 0165, T1)

If auxiliary power is required, check that it corresponds with that on the nameplate and with the test certification valid for your country.

## 4.3 Connecting the transmitter

### Requirement

Use screened cable with the following external diameter:

- 4.5 to 10 mm (0.18 to 0.39 inches) with M16 x 1.5 cable joint
- 4 to 11 mm (0.16 to 0.43 inches) with 1/2-14 NPT cable joint

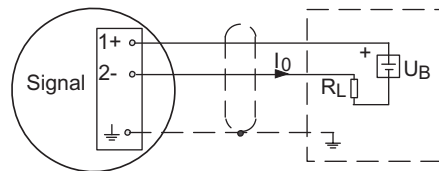

Figure 4-1 Connecting to a current output

$I_0$  Output current

$U_B$  Auxiliary power

$R_L$ : Load

Ports:

1(+ $U_B$ )

2(- $U_B$ )

4.3 Connecting the transmitter

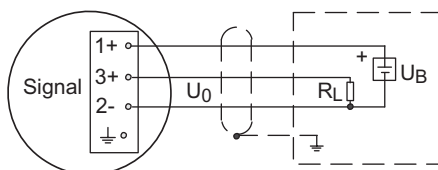

Figure 4-2 Connecting to a voltage output

$U_0$  Output voltage

$U_B$  Auxiliary power

$R_L$ : Load

Ports:

1(+ $U_B$ )

2(- $U_B$ )

3(+ $U_0$ )

### Procedure

To connect the transmitter, proceed as follows:

1. Feed in the 2 or 3 wire, screened cable in via the cable joint.
2. It is preferable to only connect the cable screen at one point e.g. in the switching cabinet.

### Result

The grounding connection on the transmitter plug is conductively bonded to the transmitter housing.

## Technical data

### 5.1 SITRANS P pressure transmitter, Z series for gauge and absolute pressure

#### Technical data

<b>How it works</b>		
Measuring span < 1 bar (< 14.5 psi)	Piezo-resistive	
Measuring span ≥ 1 bar (≥ 14.5 psi)	Thin-film strain gauge	

<b>Gauge pressure input</b>		
Measured variable	Gauge pressure	
Measuring range for gauge pressure	perm. operating pressure min. ... max.	Burst pressure
• 0 ... 100 mbar g (0 ... 1.45 psi g)	-0,6 ... 0.6 bar g (-8.7 ... 8.7 psi g)	1 bar g (14.5 psi g)
• 0 ... 160 mbar g (0 ... 2.32 psi g)	-0,6 ... 0.6 bar g (-8.7 ... 8.7 psi g)	1 bar g (14.5 psi g)
• 0 ... 250 mbar g (0 ... 3.63 psi g)	-1 ... 1 bar g (-14.5 ... 14.5 psi g)	1,7 bar g (25 psi g)
• 0 ... 400 mbar g (0 ... 5.80 psi g)	-1 ... 1 bar g (-14.5 ... 14.5 psi g)	1,7 bar g (25 psi g)
• 0 ... 600 mbar g (0 ... 8.70 psi g)	-1 ... 3 bar g (-14.5 ... 43.5 psi g)	5 bar g (72 psi g)
• 0 ... 1 bar g (0 ... 14.5 psi g)	-0,4 ... 2 bar g (-5.8 ... 30 psi g)	5 bar g (72 psi g)
• 0 ... 1.6 bar g (0 ... 23.2 psi g)	-0,4 ... 3.2 bar g (-5.8 ... 45 psi g)	5 bar g (72 psi g)
• 0 ... 2.5 bar g (0 ... 36.3 psi g)	-0,8 ... 5 bar g (-11.6 ... 72 psi g)	12 bar g (175 psi g)
• 0 ... 4 bar g (0 ... 58 psi g)	-0,8 ... 8 bar g (-11.6 ... 115 psi g)	12 bar g (175 psi g)
• 0 ... 6 bar g (0 ... 87 psi g)	-1 ... 12 bar g (-14.5 ... 175 psi g)	25 bar g (360 psi g)
• 0 ... 10 bar g (0 ... 145 psi g)	-1 ... 20 bar g (-14.5 ... 290 psi g)	50 bar g (725 psi g)
• 0 ... 16 bar g (0 ... 232 psi g)	-1 ... 32 bar g (-14.5 ... 460 psi a)	50 bar g (725 psi g)
• 0 ... 25 bar g (0 ... 363 psi g)	-1 ... 50 bar g (-14.5 ... 725 psi g)	120 bar g (1750 psi g)
• 0 ... 40 bar g (0 ... 580 psi g)	-1 ... 80 bar g (-14.5 ... 1150 psi g)	120 bar g (1750 psi g)
• 0 ... 60 bar g (0 ... 870 psi g)	1 ... 120 bar g (-14.5 ... 1750 psi g)	250 bar g (3600 psi g)
• 0 ... 100 bar g (0 ... 1450 psi g)	-1 ... 200 bar g (-14.5 ... 2900 psi g)	450 bar g (6525 psi g)
• 0 ... 160 bar g (0 ... 2321 psi g)	-1 ... 320 bar g (-14.5 ... 4640 psi g)	450 bar g (6525 psi g)

5.1 SITRANS P pressure transmitter, Z series for gauge and absolute pressure

<b>Gauge pressure input</b>		
• 0 ... 250 bar g (0 ... 3630 psi g)	-1 ... 500 bar g (-14.5 ... 7250 psi g)	650 bar g (9425 psi g)
• 0 ... 400 bar g (0 ... 5800 psi g)	-1 ... 600 bar g (-14.5 ... 8700 psi g)	650 bar g (9425 psi g)
<b>Measuring range for gauge pressure (only for U.S. market)</b>	<b>perm. operating pressure min. ... max.</b>	<b>Burst pressure</b>
• 0 ... 10 psi g	-3 ... 20 psi g	60 psi g
• 0 ... 15 psi g	-6 ... 30 psi g	72 psi g
• 3 ... 15 psi g	-6 ... 30 psi g	72 psi g
• 0 ... 20 psi g	-6 ... 40 psi g	72 psi g
• 0 ... 30 psi g	-6 ... 60 psi g	72 psi g
• 0 ... 60 psi g	-11.5 ... 120 psi g	175 psi g
• 0 ... 100 psi g	-14.5 ... 200 psi g	360 psi g
• 0 ... 150 psi g	-14.5 ... 300 psi g	725 psi g
• 0 ... 200 psi g	-14.5 ... 400 psi g	725 psi g
• 0 ... 300 psi g	-14.5 ... 600 psi g	1750 psi g
• 0 ... 500 psi g	-14.5 ... 1000 psi g	1750 psi g
• 0 ... 750 psi g	-14.5 ... 1500 psi g	3600 psi g
• 0 ... 1000 psi g	-14.5 ... 2000 psi g	3600 psi g
• 0 ... 1500 psi g	-14.5 ... 3000 psi g	6525 psi g
• 0 ... 2000 psi g	-14.5 ... 4000 psi g	6525 psi g
• 0 ... 3000 psi g	-14.5 ... 6000 psi g	9425 psi g
• 0 ... 5000 psi g	-14.5 ... 8700 psi g	9425 psi g
• 0 ... 6000 psi g	-14.5 ... 8700 psi g	9425 psi g

<b>Absolute pressure input</b>		
<b>Measured variable</b>	<b>Absolute pressure</b>	
<b>Measuring range for absolute pressure</b>	<b>perm. operating pressure min. ... max.</b>	<b>Burst pressure</b>
• 0 ... 600 mbar a (0 ... 8.7 psi a)	0 ... 3 bar a (0 psi a ... 43.5 psi a)	5 bar a (72 psi a)
• 0 ... 1 bar a (0 ... 14.5 psi a)	0 ... 2 bar a (0 psi a ... 30 psi a)	5 bar a (72 psi a)
• 0 ... 1.6 bar a (0 ... 23.2 psi a)	0 ... 3.2 bar a (0 psi a ... 45 psi a)	5 bar a (72 psi a)
• 0 ... 2.5 bar a (0 ... 36.3 psi a)	0 ... 5 bar a (0 psi a ... 72 psi a)	12 bar a (175 psi a)
• 0 ... 4 bar a (0 ... 58.0 psi a)	0 ... 8 bar a (0 psi a ... 115 psi a)	12 bar a (175 psi a)
• 0 ... 6 bar a (0 ... 87.3 psi a)	0 ... 12 bar a (0 psi a ... 175 psi a)	25 bar a (360 psi a)
• 0 ... 10 bar a (0 ... 145 psi a)	0 ... 20 bar a (0 psi a ... 290 psi a)	50 bar a (725 psi a)



5.1 SITRANS P pressure transmitter, Z series for gauge and absolute pressure

<b>Absolute pressure input</b>		
• 0 ... 16 bar a (0 ... 232 psi a)	0 ... 32 bar a (0 psi a ... 460 psi a)	50 bar a (725 psi a)
<b>Measuring range for absolute pressure (only for US market)</b>	<b>perm. operating pressure min. ... max.</b>	<b>Burst pressure</b>
• 0 ... 10 psi a	0 ... 20 psi a	60 psi a
• 0 ... 15 psi a	0 ... 30 psi a	72 psi a
• 0 ... 20 psi a	0 ... 40 psi a	72 psi a
• 0 ... 30 psi a	0 ... 60 psi a	72 psi a
• 0 ... 60 psi a	0 ... 120 psi a	175 psi a
• 0 ... 100 psi a	0 ... 200 psi a	360 psi a
• 0 ... 150 psi a	0 ... 300 psi a	725 psi a
• 0 ... 200 psi a	0 ... 400 psi a	725 psi a
• 0 ... 300 psi a	0 ... 600 psi a	1725 psi a

<b>Output</b>	
Output signal	
• Current output signal	4 ... 20 mA
Load	(U <sub>H</sub> – 10 V) / 0.02 A
• Voltage output signal (only measuring span ≥ 1 bar (14.5 psi))	DC 0 to 10 V
Load	≥ 10 kΩ
Power consumption	< 7 mA at 10 kΩ
• Characteristic curve	Linear rising

<b>Measuring accuracy</b>	
Error in measurement (at 25 °C (77 °F), including conformity error, hysteresis and repeatability)	0.25 % of full scale value - typical (0.5 % of full scale value - max.)
Settling time T <sub>63</sub>	< 0.1 s
Long-term drift	
• Start of scale	0.25 % of full scale value/year
• Full scale value	0.25 % of full scale value/year
Influence of ambient temperature	
• Start of scale	0.25 %/10 K of full scale value
	0.5 %/10 K of full scale value. This holds for measuring cells with the following measuring range for gauge pressure:
	0 ... 100 mbar g (0 ... 1.45 psi g)
	0 ... 160 mbar g (0 ... 2.32 psi g)
	0 ... 250 mbar g (0 ... 3.63 psi g)
	0 ... 400 mbar g (0 ... 5.80 psi g)

---

**Measuring accuracy**

---

• Full scale value	0.25 %/10 K of full scale value 0.5 %/10 K of full scale value. This holds for measuring cells with the following measuring range for gauge pressure: 0 ... 100 mbar g (0 ... 1.45 psi g) 0 ... 160 mbar g (0 ... 2.32 psi g) 0 ... 250 mbar g (0 ... 3.63 psi g) 0 ... 400 mbar g (0 ... 5.80 psi g)
Influence of auxiliary power	0.005 %/V
Influence of vibration according to IEC 60068-2-64	0.05 %/g

---



---

**Operating conditions**

---

Process temperature	-30 °C ... +120 °C (-22 °F ... +248 °F)
Ambient temperature	-25 °C ... +85 °C (-13 °F ... +185 °F)
Storage temperature	-50 °C ... +100 °C (-58 °F ... +212 °F)
Type of protection to EN 60 529	IP65
Electromagnetic compatibility	
• Spurious emission and resistance to interference	As per EN 61326 and NAMUR NE 21
• Measurement errors	< 1% of full scale value Cable screen is not connected to ground connection.

---



---

**Construction**

---

Weight	Approx. 0.25 kg (approx. 0.55 lb)
Process connection	<ul style="list-style-type: none"> <li>• G½ external</li> <li>• Male thread G½ and internal (female) thread G¾</li> <li>• Male thread G¼</li> <li>• Male thread 7/16-20 UNF</li> <li>• Male thread ¼-18 NPT</li> <li>• Female thread ¼-18 NPT</li> <li>• Male thread ½-14 NPT</li> <li>• Female thread ½-14 NPT</li> <li>• Male thread G1" with flush-mounted diaphragm</li> </ul>
Electrical connection	
• Connectors	To DIN 43650, type A
• Cable entry	M16 x 1.5 or ½-14 NPT
Material of the wetted parts	
• Measuring cell	
Measuring span < 1 bar (< 14.5 psi)	Stainless steel, mat.no. 1.4571/316Ti filled with silicone oil
Measuring span ≥ 1 bar (≥ 14.5 psi)	AL <sub>2</sub> O <sub>3</sub> - 96 %

5.1 SITRANS P pressure transmitter, Z series for gauge and absolute pressure

**Construction**

• Process connection	Stainless steel, mat. no. 1.4571/316Ti
• Gasket	Viton (FPM) from -15 °C ... +125 °C (+5 °F ... +257 °F)
	Neoprene (CR) from -35 °C ... +100 °C; < 100 bar (-31 °F ... +212 °F; < 1450 psi)
	Perbunan (NBR) from -20 °C ... +100 °C (-4 °F ... +212 °F)
Material of parts not in contact with the medium	
• Casing	Stainless steel, mat. no. 1.4571/316Ti
• Plug-in connectors	Plastic housing to DIN A43650, type A

**Auxiliary power U<sub>H</sub>**

Terminal voltage on pressure transmitter

• For current output	DC 10 ... 36 V (DC 10 ... 30 V for Ex)
• For voltage output (measuring span ≥ 1 bar (14.5 psi) only)	DC 5 to 36 V DC

**Certificates and approvals**

Classification according to Pressure Equipment Directive (PED 97/23/EC)	For gases of Fluid Group 1 and liquids of Fluid Group 1; meets requirements of Article 3 Para. 3 (Good engineering practice)
Explosion protection	
• Intrinsic safety "i" (with current output only)	TÜV 02 ATEX 1953X
Marking	Ex II 1/2 G EEx ia IIC T4
Connection to certified intrinsically safe circuits with maximum values	U <sub>i</sub> = 30 V; I <sub>i</sub> = 100 mA; P <sub>i</sub> = 0.75 W
Effective internal inductance and capacitance	L <sub>i</sub> = 2.2 nH; C <sub>i</sub> = 37.9 nF
• Intrinsic safety "T.I.I.S" (with current output only)	Applied for
Lloyds Register of Shipping	05/20049(E1)



## Dimensional drawings

### 6.1 SITRANS P, Z series gauge pressure/absolute pressure

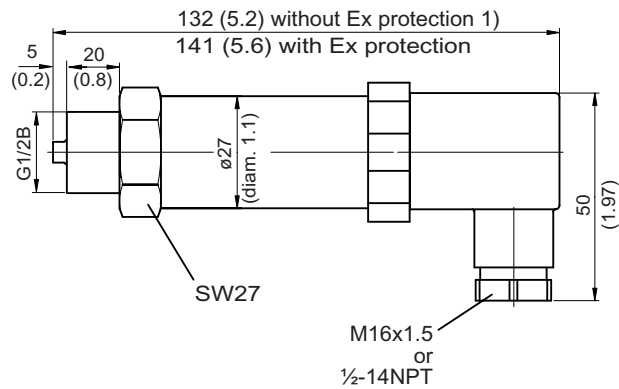

Figure 6-1 Transmitter with male G $\frac{1}{2}$ " process connection, dimensions in mm (inches)

- 1) Length on version with voltage output: 106 (4.2)

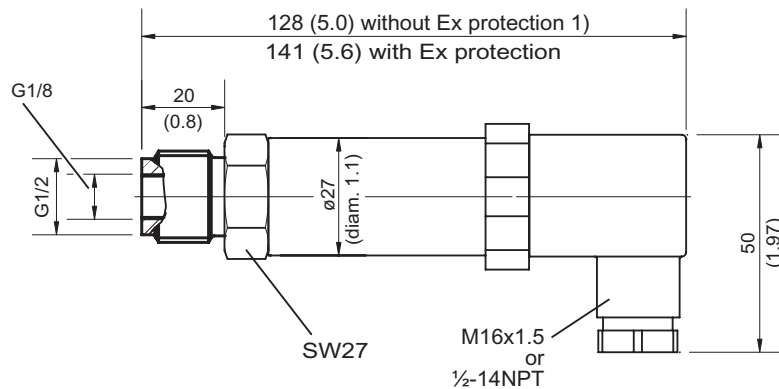

Figure 6-2 Transmitter with male G $\frac{1}{2}$ " and female G $\frac{1}{8}$ " process connection, dimensions in mm (inches)

- 1) Length on version with voltage output: 102 (4.1)

6.1 SITRANS P, Z series gauge pressure/absolute pressure

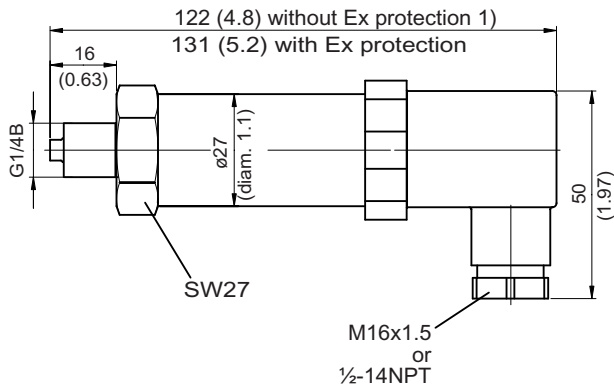

Figure 6-3 Transmitter with male G1/4" process connection, dimensions in mm (inches)

- 1) Length on version with voltage output: 96 (3.8)

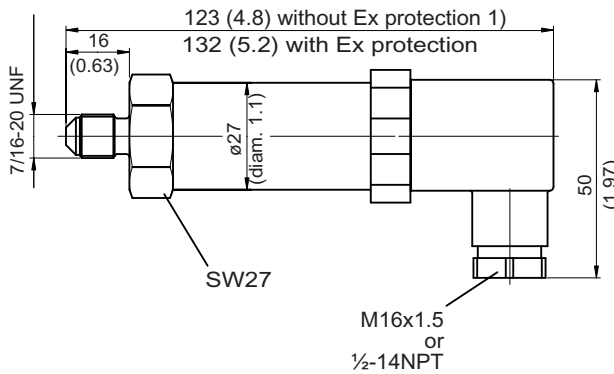

Figure 6-4 Transmitter with male 7/16-20 UNF process connection, dimensions in mm (inches)

- 1) Length on version with voltage output: 97 (3.8)

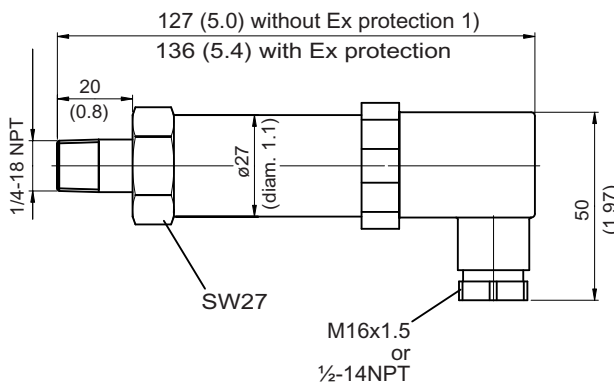

Figure 6-5 Transmitter with male 1/4"-18 NPT process connection, dimensions in mm (inches)

- 1) Length on version with voltage output: 101 (4.0)

6.1 SITRANS P, Z series gauge pressure/absolute pressure

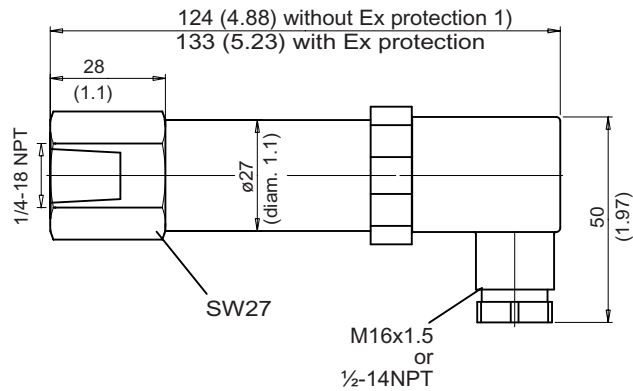

Figure 6-6 Transmitter with 1/4"-18 NPT female process connection, dimensions in mm (inches)

- 1) Length on version with voltage output: 98 (3.9)

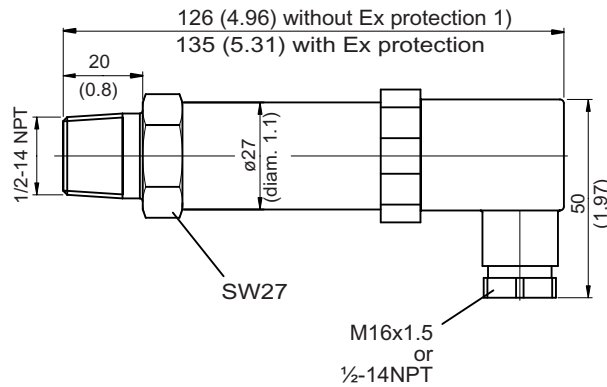

Figure 6-7 Transmitter with male 1/2"-14 NPT process connection, dimensions in mm (inches)

- 1) Length on version with voltage output: 100 (4.0)

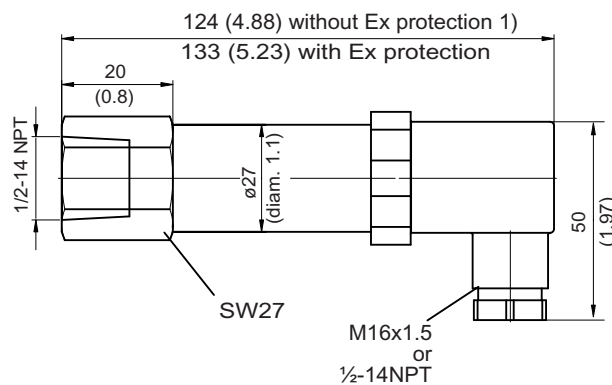

Figure 6-8 Transmitter with 1/2"-14 NPT female process connection, dimensions in mm (inches)

- 1) Length on version with voltage output signal: 98 (3.9)

6.1 SITRANS P, Z series gauge pressure/absolute pressure

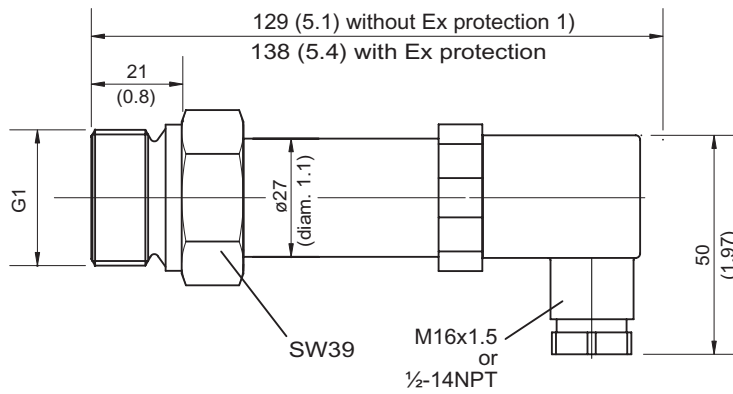

Figure 6-9 Transmitter with male G1" process connection with flush-mounted diaphragm dimensions in mm (inches)

1) Length on version with voltage output signal: 103 (4.1)