

PROGRAMMABLE LOGIC CONTROLLER

MODEL

FX3GE

QUICK START MANUAL



1. INTRODUCTION	3	5. BUILT-IN ETHERNET	11
1.1 CAUTION.....	3	5.1 ETHERNET SPECIFICATIONS AND WIRING.....	11
1.2 INCLUDED ITEMS	3	5.2 PARAMETER SETTINGS AND DIAGNOSTICS IN GX WORKS2.....	12
1.3 FRONT PANEL	3	6. BUILT-IN ANALOG SPECIFICATIONS AND WIRING	19
2. DIMENSIONS	4	6.1 ANALOG INPUT TERMINAL BLOCK	19
3. INSTALLATION	4	7. PROGRAMMING USING GX WORKS2	21
3.1 SPECIFICATIONS.....	5	7.1 SYSTEM CONFIGURATION.....	21
3.2 MOUNTING INSTRUCTIONS.....	6	7.2 INSTALLING THE USB DRIVER	21
4. SPECIFICATIONS AND WIRING	7	7.3 INSTALLING GX WORKS2.....	23
4.1 WIRING.....	7	7.4 STARTING AND EXITING GX WORKS2	24
4.2 GROUNDING	8	7.5 USING THE HELP FILES IN GX WORKS2.....	24
4.3 POWER SUPPLY SPECIFICATIONS AND WIRING DIAGRAM	8	8. OPERATION	25
4.4 INPUT SPECIFICATIONS AND WIRING DIAGRAM.....	8	9. MAINTENANCE	27
4.5 PULSE CATCH (M8170 TO M8175).....	9	10. TROUBLESHOOTING	28
4.6 PULSE WIDTH/PULSE PERIOD MEASUREMENT SPECIFICATIONS AND WIRING	9		
4.7 HIGH SPEED COUNTERS SPECIFICATIONS AND WIRING	9		
4.8 OUTPUT SPECIFICATIONS AND WIRING	10		

1. INTRODUCTION

This manual describes the part names, dimensions, mounting, and specifications of the product. Before use, read this manual and the manuals of all relevant products fully to acquire proficiency in handling and operating the product. Make sure to learn all the product information, safety information, and precautions.

Store this manual in a safe place so that it can be taken out and read whenever necessary. Always forward it to the end user.

Registration

The company name and the product name to be described in this manual are the registered trademarks or trademarks of each company.

Effective August 2013

Specifications are subject to change without notice.

© 2013 Mitsubishi Electric Corporation

1.1 CAUTION

Safety Precaution (Read these precautions before use.) This manual classifies the safety precautions into two categories: **ANGER** and **CAUTION**.

 **DANGER** Indicates that incorrect handling may cause hazardous conditions, resulting in death or severe injury.

 **CAUTION** Indicates that incorrect handling may cause hazardous conditions, resulting in medium or slight personal injury or physical damage.

Depending on the circumstances, procedures indicated by **CAUTION** may also cause severe injury. It is important to follow all precautions for personal safety.

DANGER STARTUP AND MAINTENANCE PRECAUTIONS

- Do not touch any terminal while the PLC's power is on. Doing so may cause electric shock or malfunctions.
- Before cleaning or retightening terminals, cut off all phases of the power supply externally. Failure to do so may cause electric shock.
- Use the battery for memory backup correctly
 - ▶ Use the battery only for the specified purpose.
 - ▶ Connect the battery correctly.
 - ▶ Do not charge, disassemble, heat, put in fire, short-circuit, connect reversely, weld, swallow or burn the battery, or apply excessive forces (vibration, impact, drop, etc.) to the battery.
 - ▶ Do not store or use the battery at high temperatures or expose to direct sunlight.
 - ▶ Do not expose to water, bring near fire or touch liquid leakage or other contents directly.
 - ▶ Incorrect handling of the battery may cause heat excessive generation, bursting, ignition, liquid leakage or deformation, and lead to injury, fire or failures and malfunctions of facilities and other equipment.
- Before modifying or disrupting the program in operation or running the PLC, carefully read through this manual to ensure the safety of the operation. An operation error may damage the machinery or cause accidents.

CAUTION STARTUP AND MAINTENANCE PRECAUTIONS

- Do not disassemble or modify the PLC. Doing so may cause fire, equipment failures, or malfunctions.

- Turn off the power to the PLC before connecting or disconnecting any extension cable. Failure to do so may cause equipment failures or malfunctions.
- Turn off the power to the PLC before attaching or detaching the following devices. Failure to do so may cause equipment failures or malfunctions.
 - ▶ Peripheral devices, display module, battery, and expansion boards

CAUTION DISPOSAL PRECAUTIONS

Please contact a certified electronic waste disposal company for the environmentally safe recycling and disposal of your device. When disposing of batteries, separate them from other waste according to local regulations.

CAUTION TRANSPORT AND STORAGE PRECAUTIONS

- When transporting the FX3GE Series PLC incorporating the optional battery, turn on the PLC before shipment, confirm that the battery mode is set using a parameter and the ALM LED is OFF, and check the battery life. If the PLC is transported with the ALM LED on or the battery exhausted, the battery-backed data may be unstable during transportation.
- The PLC is a precision instrument. During transportation, avoid impacts larger than those specified in this manual. Failure to do so may cause failures in the PLC. After transportation, verify the operations of the PLC.
- When transporting lithium batteries, follow required transportation regulations.

1.2 INCLUDED ITEMS

Check if the following product and items are included in the package:

MAIN UNIT		
FX3GE-24MR/ES	Product	1 unit
	Dust proof protection sheet	1 sheet
	Manual [English version]	1 manual

1.3 FRONT PANEL

■ FACTORY DEFAULT CONFIGURATION (STANDARD)

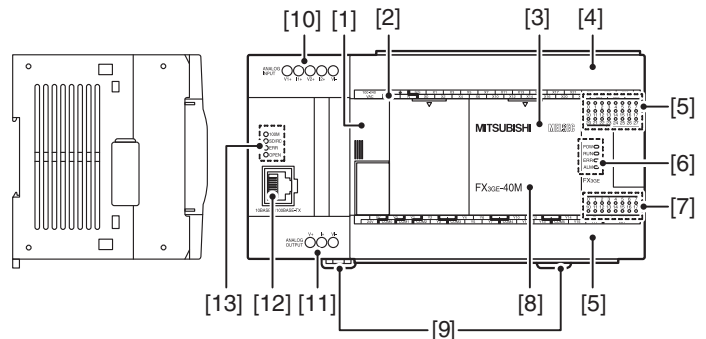

[1] Peripheral device connector cover The peripheral device connector, variable analog potentiometers and RUN/STOP switch are located under this cover.

[2] Terminal names The signal names for power supply, input and output terminals are shown.

[3] Top cover (S) (40 points, 60 points type only) Mount the expansion board under this cover.

[4] Terminal block covers The covers can be opened for wiring. Keep the covers closed while the PLC is running (the unit power is on).

[5] Input display LEDs (red) When an input terminal (X000 or more) is turned on, the corresponding LED lights.

[6] Operation status display LEDs The operation status of the PLC can be checked with the LEDs. The LEDs turn off, light and flash according to the following table. For details on the operation status, refer to Section 10.

LED Name	Display Color	Description
POW	Green	On while power is on the PLC.
RUN	Green	On while the PLC is running.
ERR	Red	Flashing when a program error occurs. Lights when a CPU error occurs.
ALM	Red	Lights when the battery voltage drops. (When the optional battery is used)

[7] Output display LEDs (red) When an output terminal (Y000 or more) is turned on, the corresponding LED lights.

[8] Model name (abbreviation) The model name of the main unit is indicated. Check the nameplate on the right side for the model name.

[9] DIN rail mounting hooks The main unit can be installed on DIN46277 rail (35mm (1.38") wide).

[10] Analog input terminal block

[11] Analog output terminal block

[12] 10BASE-T/100BASE-TX connector (RJ45)

[13] Ethernet status LEDs

■ WITH TERMINAL COVER OPEN

[1] Peripheral device connector (USB) Connect a programming tool

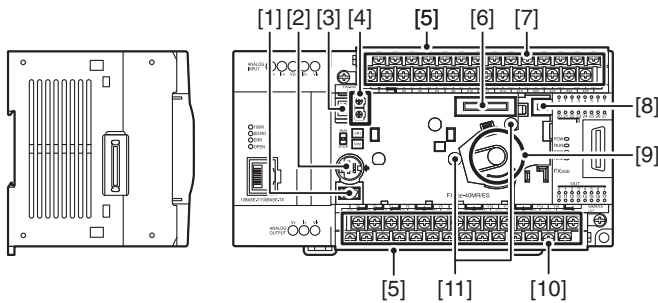

(PC) to program a sequence.

[2] Peripheral device connector (RS-422) Connect a programming tool to program a sequence.

[3] RUN/STOP switch To stop writing (batch) of the sequence program or operation, set the switch to STOP (slide it downward). To start operation (run the machine), set it to RUN (slide it upward).

[4] Variable analog potentiometers Upper side: VR1, Lower side: VR2 Two variable analog potentiometers are built in. Upper side : VR1, Lower side : VR2

[5] Terminal cover A protective terminal cover

[6] Optional equipment connector Connect the expansion board to the connector.

[7] Power supply terminal, Input (X) terminals Wire switches and sensors to the terminals.

[8] Battery connector Connect the optional battery to the connector.

[9] Battery holder This holder accommodates the optional battery.

[10] Power supply terminal, Output (Y) terminals Wire loads (contactors, solenoid valves, etc.) to be driven to the terminals.

[11] Optional equipment connecting screw holes These holes are designed to secure the expansion board and memory cassette with screws.

■ LED STATUS

LED Display	LED Color	Status	Description
POW	Green	ON	Power is on
		OFF	Power is off
RUN	Green	ON	Running
		OFF	Stopped
ERR	Red	ON	When a CPU error occurs
		Flicker	When a program error occurs
		OFF	When a normal status
ALM	Red	ON	When the battery voltage drops (When the optional battery is installed)
		OFF	When the battery voltage normal status

2. DIMENSIONS

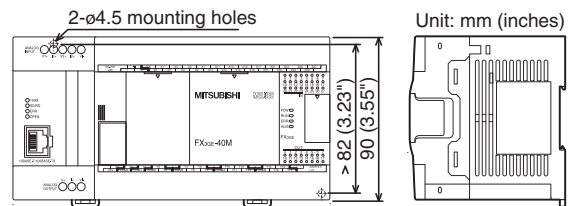

Model Number	W: mm (inches)	W1: mm (inches) Direct Mounting Hole Pitches	Weight: kg (lbs)
FX3GE-24MR/ES	130 (5.12")	105 (4.13")	0.60 (1.32 lbs)

Installation: 35mm wide DIN rail or Direct (screw) mounting (M4)

3. INSTALLATION

CAUTION INSTALLATION PRECAUTIONS

- Use the product within the generic environment specifications described in this manual. Never use the product in areas with excessive dust, oily smoke, conductive dusts, corrosive gas (salt air, Cl2, H2S, SO2 or NO2), flammable gas, vibration or impacts, or exposed to high temperature, condensation, or rain and wind. If the product is used in such conditions, electric shock, fire, malfunctions, deterioration or damage may occur.
- Do not touch the conductive parts of the product directly to avoid failure or malfunctions.
- Install the product securely using a DIN rail or mounting screws.
- Install the product on a flat surface. If the mounting surface is rough, undue force will be applied to the PC board, thereby causing nonconformities.
- When drilling screw holes or wiring, make sure cutting or wire debris does not enter the ventilation slits. Failure to do so may cause fire, equipment failures or malfunctions.
- Be sure to remove the dust proof sheet from the PLC's ventilation port when installation work is completed. Failure to do so may cause fire, equipment failures or malfunctions.

- Connect the extension cables, peripheral device cables, input/output cables and battery connecting cable securely to their designated connectors. Unsecured connection may cause malfunctions.
- Turn off the power before attaching or detaching the following devices. Failure to do so may cause device failures or malfunctions.
 - ▶ Peripheral devices, display modules and battery.
- When a dust proof sheet is supplied with units, keep the sheet applied to the ventilation slits during installation and wiring work.
- To prevent temperature rise, do not install the PLC on a floor, a ceiling or a vertical surface. Install it horizontally on a wall.
- Keep a space of 50mm (1.97") or more between the unit main body and another device or structure (part A). Install the unit as far away as possible from highvoltage lines, high-voltage devices and power equipment.

DANGER WIRING PRECAUTIONS

- Make sure to cut off all phases of the power supply externally before attempting installation or wiring work. Failure to do so may cause electric shock or damage to the product.

3.1 SPECIFICATIONS

■ COMPLIANCE WITH EC DIRECTIVE (CE MARKING)

This document does not guarantee that a mechanical system including this product will comply with the following standards. Compliance to EMC directive and LVD directive of the entire mechanical system should be checked by the user / manufacturer.

■ REQUIREMENT FOR COMPLIANCE WITH EMC DIRECTIVE

The following products have shown compliance through direct testing (of the identified standards below) and design analysis (through the creation of a technical construction file) to the European Directive for Electromagnetic Compatibility (2004/108/EC) when used as directed by the appropriate documentation.

ATTENTION

- This product is designed for use in industrial applications.
- Manufactured by:
Mitsubishi Electric Corporation
2-7-3 Marunouchi, Chiyoda-ku, Tokyo, 100-8310 Japan
- Manufactured at:
Mitsubishi Electric Corporation Himeji Works
840 Chiyoda-machi, Himeji, Hyogo, 670-8677 Japan
- Authorized Representative in the European Community:
Mitsubishi Electric Europe B.V.
Gothaer Str. 8, 40880 Ratingen, Germany

Type: Programmable Controller (Open Type Equipment)

Models: MELSEC FX3GE series, FX3G series, FX3U series

Manufactured:

from November 1st, 2008

FX3G-232-BD

FX3G-422-BD

FX3G-5DM

from March 1st, 2013

FX3GE-24MR/ES

from September 1st, 2013

FX3G-485-BD-RJ

Standard	REMARK
EN61131-2:2007 Programmable controllers - Equipment requirements and tests	Compliance with all relevant aspects of the standard. EMI • Radiated Emissions • Conducted Emissions EMS • Radiated electromagnetic field • Fast transient burst • Electrostatic discharge • High-energy surge • Voltage drops and interruptions • Conducted RF • Power frequency magnetic field

■ REQUIREMENT FOR COMPLIANCE WITH LVD DIRECTIVE

The following products have shown compliance through direct testing (of the identified standards below) and design analysis (through the creation of a technical construction file) to the European Directive for Low Voltage (2006/95/EC) when used as directed by the appropriate documentation.

Type: Programmable Controller (Open Type Equipment)

Models: MELSEC FX3GE series

Manufactured: from March 1st, 2013 FX3GE-24MR/ES

Standard	REMARK
EN61131-2:2007 Programmable controllers - Equipment requirements and tests	The equipment has been assessed as a component for fitting in a suitable enclosure which meets the requirements of EN61131-2:2007

■ CAUTION FOR COMPLIANCE WITH EC DIRECTIVE

Installation in Enclosure

Programmable logic controllers are open-type devices that must be installed and used within conductive control boxes. Please use the FX3GE Series programmable logic controllers while installed in conductive shielded control boxes. Please secure the control box lid to the control box (for conduction). Installation within a control box greatly affects the safety of the system and aids in shielding noise from the programmable logic controller.

Analog input/output

The analog input/output have been found to be compliant to the European standards in the aforesaid manual and directive. However, for the very best performance from what are in fact delicate measuring and controlled output devices, Mitsubishi Electric would like to make the following points.

As analog devices are sensitive by nature, their use should be considered carefully. For users of proprietary cables (integral with sensors or actuators), these users should follow those manufacturers' installation requirements. Mitsubishi Electric recommends that shielded cables be used. If NO other EMC protection is provided, users may experience temporary loss or accuracy between +10% / -10% in very heavy industrial areas. However, Mitsubishi Electric suggests that adequate EMC precautions be followed for the users complete control system.

- ▶ Sensitive analog cables should not be laid in the same trunking or cable conduit as high voltage cabling. Where possible, users should run analog cables separately.
- ▶ Good cable shielding should be used. When terminating the shield at Earth, ensure that no earth loops are accidentally created.
- ▶ When reading analog values, EMC accuracy can be improved by averaging the readings. This can be achieved either through functions on the analog products or through a user's program in the FX3GE Series PLC main unit.

Item	Specification				
Ambient Temperature	0 to 55°C (32 to 131°F) when operating and -25 to 75°C (-13 to 167°F) when stored				
Ambient Humidity	5 to 95%RH (no condensation) when operating				
Vibration Resistance *1		Frequency (Hz)	Acceleration (m/s ²)	Half amplitude (mm)	Sweep Count for X, Y, Z: 10 times (80 min in each direction)
	When installed on DIN rail	10 to 57	-	0.035	
		57 to 150	4.9	-	
	When installed directly	10 to 57	-	0.075	
57 to 150		9.8	-		
Shock Resistance *1	147m/s ² Acceleration, Action time: 11ms, 3 times by half-sine pulse in each direction X, Y, and Z				
Noise Resistance	By noise simulator at noise voltage of 1,000Vp-p, noise width of 1μs, rise time of 1ns and period of 30 to 100Hz				
Dielectric Withstand Voltage *2	1.5kVAC for one minute		Between each terminals *2 and ground terminal		
	500VAC for one minute				
Insulation Resistance *2	5MΩ or more by 500VDC megger				
Grounding	Class D grounding (grounding resistance: 100Ω or less) <Common grounding with a heavy electrical system is not allowed.> *3				
Working Atmosphere	Free from corrosive or flammable gas and excessive conductive dusts				
Working Altitude	<2000m *4				

Terminal	Dielectric Strength	Insulation Resistance
Main units		
Between power supply terminal (AC power) and ground terminal	1.5 kVAC for one minute	5MΩ or more by 500VDC megger
Between power supply terminal (DC power) and ground terminal	500VAC for one minute	
Between input terminal (24VDC) and ground terminal	500VAC for one minute	
Between output terminal (relay) and ground terminal	1.5 kVAC for one minute	
10BASE-T/100BASE-TX connector and ground terminal	500VAC for one minute	
Main unit analog terminal and ground terminal	Not allowed	Not allowed

1. The criterion is shown in IEC61131-2.
2. Dielectric withstand voltage and insulation resistance are shown above.
3. For common grounding, refer to Section 4.2.
4. The PLC cannot be used at a pressure higher than the atmospheric pressure to avoid damage.

3.2 MOUNTING INSTRUCTIONS

■ INSTALLATION LOCATION

Install the PLC in an environment conforming to the generic specifications, installation precautions and notes.

Installation location in enclosure

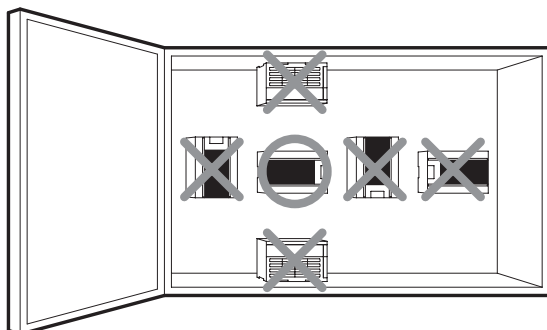

Space enclosure

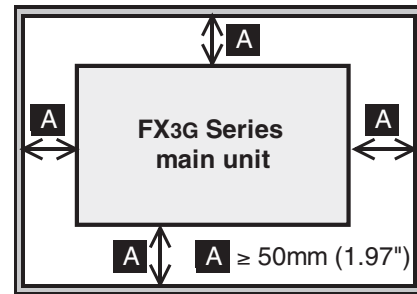

■ AFFIXING THE DUST PROOF SHEET

The dust proof sheet should be affixed to the ventilation port before beginning the installation and wiring work. **For the affixing procedure, refer to the instructions on the dust proof sheet.** Be sure to remove the dust proof sheet when the installation and wiring work is completed.

■ PROCEDURES FOR INSTALLING TO AND DETACHING FROM DIN RAIL

The products can be installed on a DIN46277 rail [35mm (1.38") wide].

- 1) Push out all DIN rail mounting hooks (below fig. A).

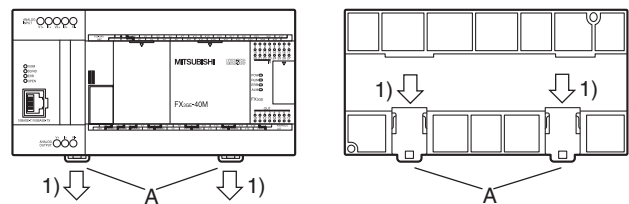

- 2) Fit the upper edge of the DIN rail mounting groove (below fig. B) onto the DIN rail.

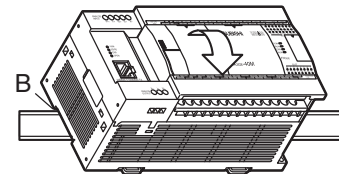

- 3) Lock the DIN rail mounting hooks (below fig. C) while pressing the PLC against the DIN rail.

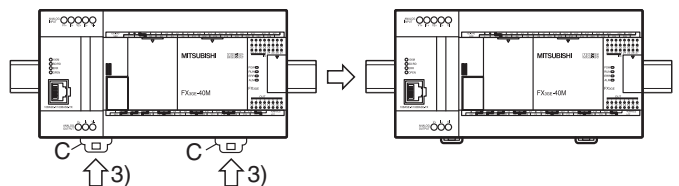

■ PROCEDURES FOR MOUNTING WITH M4 SCREWS

MOUNTING HOLE PITCHES

Refer to the External Dimensions (Section 2) for the product's mounting hole pitch information

■ INSTALLATION

1) Make mounting holes in the mounting surface referring to the external dimensions diagram.

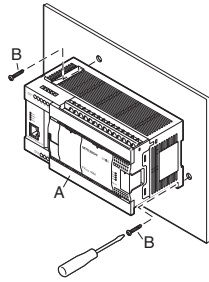

2) Fit the main unit (A in the above figure) based on the holes, and secure it with M4 screws (B in the above figure). The mounting hole pitches and number of screws depend on the product. Refer to the external dimensions diagram.

4. SPECIFICATIONS AND WIRING

DANGER DESIGN PRECAUTIONS

- Make sure to have the following safety circuits outside of the PLC to ensure safe system operation even during external power supply problems or PLC failure. Otherwise, malfunctions may cause serious accidents.
 - ▶ Most importantly, have the following: an emergency stop circuit, a protection circuit, an interlock circuit for opposite movements (such as normal vs. reverse rotation), and an interlock circuit (to prevent damage to the equipment at the upper and lower positioning limits).
 - ▶ Note that when the PLC CPU detects an error, such as a watchdog timer error, during self-diagnosis, all outputs are turned off. Also, when an error that cannot be detected by the PLC CPU occurs in an input/output control block, output control may be disabled. External circuits and mechanisms should be designed to ensure safe machinery operation in such a case.
 - ▶ Note that when an error occurs in a relay the output could be held either on or off. For output signals that may lead to serious accidents, external circuits and mechanisms should be designed to ensure safe machinery operation in such a case.
- Do not bundle the control line together with or lay it close to the main circuit or power line. As a guideline, lay the control line at least 100mm (3.94") or more away from the main circuit or power line. Noise may cause malfunctions.
- Install module so that excessive force will not be applied to the built-in programming connectors, power connectors or I/O connectors. Failure to do so may result in wire damage/breakage or PLC failure.
- Even if the AC power supply causes an instantaneous power failure for less than 10 ms, the PLC can continue to operate.
- If a long-time power failure or an abnormal voltage drop occurs, the PLC stops, and output is turned off. When the power supply is restored, it will automatically restart (when the RUN input is on).

CAUTION WIRING PRECAUTIONS

- Connect the AC power supply to the dedicated terminals specified in this manual. If an AC power supply is connected to a DC input/output terminal or DC power supply terminal, the PLC will burn out.
- Do not wire vacant terminals externally. Doing so may damage the product.

- Use class D grounding (grounding resistance of 100Ω or less) with a wire of 2mm² or thicker on the grounding terminal of the FX3GE Series main unit. However, do not connect the ground terminal at the same point as a heavy electrical system.
- When drilling screw holes or wiring, make sure cutting or wire debris does not enter the ventilation slits. Failure to do so may cause fire, equipment failures or malfunctions.
- Make sure to properly wire to the terminal in accordance with the following precautions. Failure to do so may cause electric shock, equipment failures, a short-circuit, wire breakage, malfunctions, or damage to the product.
 - ▶ The disposal size of the cable end should follow the dimensions described in the manual.
 - ▶ Tightening torque should follow the specifications in the manual.
- Input/output wiring 50 to 100m (164'1" to 328'1") long will cause almost no problems of noise, but, generally, the wiring length should be less than 20m (65'7") to ensure the safety.

4.1 WIRING

■ CABLE END TREATMENT AND TIGHTENING TORQUE

- For the terminals of FX3GE series PLC, M3 screws are used. The electric wire ends should be treated as shown below.
- Tighten the screws to a torque of 0.5 to 0.8 N•m.
- Do not tighten terminal screws with a torque exceeding the regulation torque.
- Failure to do so may cause equipment failures or malfunctions.

■ WHEN ONE WIRE IS CONNECTED TO ONE TERMINAL

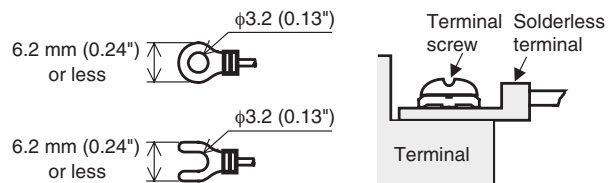

Terminal Manufacturer	Type No.	Certification	Pressure Bonding Tool
JAPAN SOLDERLESS TERMINAL MFG CO LTD (JST)	FV1.25-B3A	UL Listed	YA-1(JST)
	FV2-MS3		

■ WHEN TWO WIRES ARE CONNECTED TO ONE TERMINAL

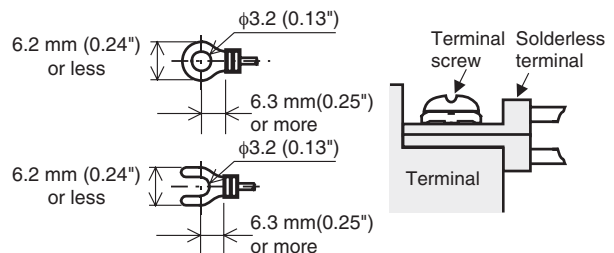

Terminal Manufacturer	Type No.	Certification	Pressure Bonding Tool
JAPAN SOLDERLESS TERMINAL MFG CO LTD (JST)	FV1.25-B3A	UL Listed	YA-1(JST)

4.2 GROUNDING

Ground the PLC as stated below.

- Perform class D grounding. (Grounding resistance: 100Ω or less)
- Ground the PLC independently if possible.

If it cannot be grounded independently, ground it jointly as shown below.

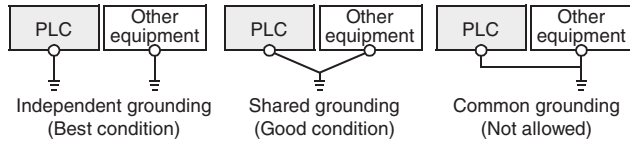

- Use ground wires thicker than AWG14 (2 mm²).
- Position the grounding point as close to the PLC as possible to decrease the length of the ground wire.

4.3 POWER SUPPLY SPECIFICATIONS AND WIRING DIAGRAM

■ POWER SUPPLY SPECIFICATIONS FX3GE-24MR/ES

Item	Specification
	AC Power Type
Supply Voltage	100 to 240VAC
Allowable Supply Voltage Range	85 to 264VAC
Rated Frequency	50/60Hz
Allowable Instantaneous Power Failure Time	Operation can be continued upon occurrence of instantaneous power failure for 10 ms or less.
Power Fuse	250V 1A
Rush Current	30A max. 5ms or less/100 VAC 50A max. 5ms or less/200 VAC
Power Consumption *1	32W
24VDC Service Power Supply	400mA

*1 This item shows values when all 24VDC service power supplies are used in the maximum configuration connectable to the main unit.

■ EXAMPLE OF EXTERNAL WIRING (AC POWER TYPE)

100 to 240VAC power is supplied to the main unit and input/output extension unit.

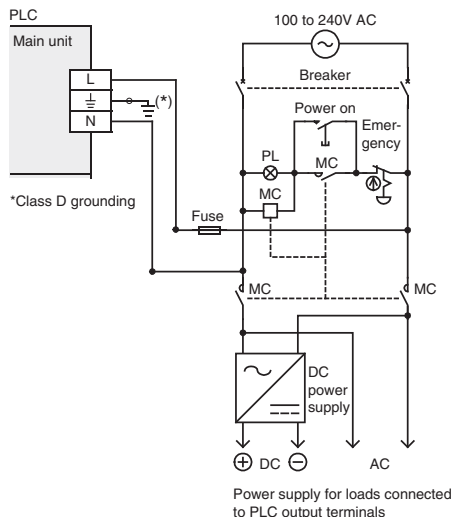

4.4 INPUT SPECIFICATIONS AND WIRING DIAGRAM

■ 24VDC INPUT [TYPE

Item	FX3GE-24MR/ES
Number of Input Points	14 points (16 points) *1
Input Connecting Type	Terminal block (M3 screw)
Input Form	Sink/Source
Input Signal Voltage	AC power supply type: 24V DC +10%, -10%
Input Impedance	X000 to X007 3.3kΩ X010 or More 4.3kΩ
Input Signal Current	X000 to X007 7mA/24VDC X010 or More 5mA/24VDC
ON Input Sensitivity Current	X000 to X007 4.5mA or more X010 or More 3.5mA or more
OFF Input Sensitivity Current	1.5mA or less
Input Response Time	Approx. 10ms
Input Signal Form	No-voltage contact input Sink input: NPN open collector transistor Source input: PNP open collector transistor
Input Circuit Insulation	Photocoupler insulation
Input Operation Display	LED on panel lights when photocoupler is driven

*1 Each value inside () indicates the number of occupied points.

EXAMPLES OF INPUT WIRING (AC POWER TYPE)

1. Each value inside () indicates the number of occupied points.

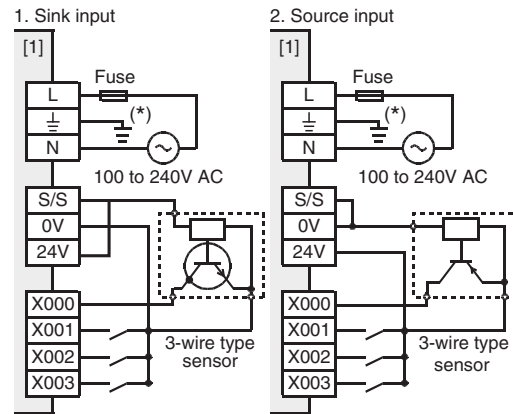

(*) Class D grounding

■ INSTRUCTIONS FOR CONNECTING INPUT DEVICES

In the case of no-voltage contact The input current of this PLC is 5 to 7mA/24VDC. Use input devices applicable to this current. If no-voltage contacts (switches) for large current are used, contact failure may occur.

In the case of input device with built-in series diode The voltage drop of the series diode should be approx. 4V or less. When lead switches with a series LED are used, up to two switches can be connected in series. Also make sure that the input current is over the input-sensing level while the switches are ON.

In the case of input device with built-in parallel resistance Use a device with a parallel resistance of 15kΩ or more. When the resistance is less than 15kΩ, connect a bleeder resistance.

In the case of 2-wire proximity switch Use a two-wire proximity switch whose leakage current is 1.5mA or less when the switch is off. When the current is 1.5mA or more, connect a bleeder resistance.

4.5 PULSE CATCH (M8170 TO M8175)

The PLC (main unit) is provided with a pulse catch function and has 6 pulse catch input points.

For details on programming, refer to the HELP section in GX Works2.

■ CAUTIONS FOR PULSE CATCH

1. Non-overlap of input numbers

The input terminals X000 to X005 can be used for high-speed counter, input interruption, pulse catch, speed detection (SPD) instructions and general-purpose input. Take care not to overlap the input numbers.

2. Cautions in wiring

It is recommended to use shielded twisted-pair cables for connection cables.

■ EXAMPLES OF EXTERNAL WIRING

It is recommended to use shielded twisted-pair cables for connection cables. Ground the shield of each shielded cable only on the PLC side.

■ EXAMPLES OF PULSE CATCH (M8170) WIRING USING X000

When another input terminal is used, wire it according to the following diagrams.

1) When 24VDC service power supply is used

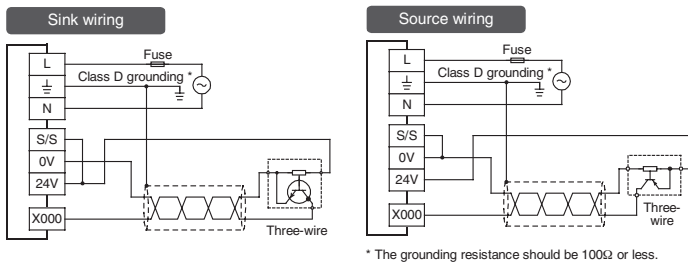

2) When 24VDC external power supply is used

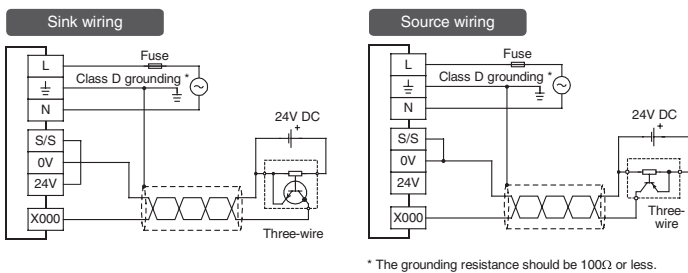

4.6 PULSE WIDTH/PULSE PERIOD MEASUREMENT SPECIFICATIONS AND WIRING

Four input points in the PLC (main unit) can be used for the pulse width/period measurement function which enables measurement of the pulse width or pulse frequency in units of 10 s.

For details on programming, refer to the HELP section in GX Works2.

■ CAUTIONS FOR PULSE WIDTH/PERIOD MEASUREMENT FUNCTION

1. Non-overlap of input numbers

The input terminals X000, X001, X003 and X004 can be used for high-speed counter, input interruption, pulse catch, speed detection

(SPD) instructions and general-purpose input. Take care not to overlap the input numbers. However, overlap of input numbers is allowed for input interruptions.

2. When the pulse width/period measurement function and high-speed counters are used together, the overall frequency of high-speed counters is affected.

3. Make sure that the total frequency of four input channels is 50 kHz or less when using the pulse width/period measurement function. For details on programming, refer to the HELP section in GX Works2.

4. Cautions in wiring

It is recommended to use shielded twisted-pair cables for connection cables.

■ EXAMPLES OF EXTERNAL WIRING

It is recommended to use shielded twisted-pair cables for connection cables. Ground the shield of each shielded cable only on the PLC side.

■ EXAMPLES OF PULSE WIDTH MEASUREMENT WIRING USING X000

When another input terminal is used, wire it according to the following diagrams.

1) When 24VDC service power supply is used

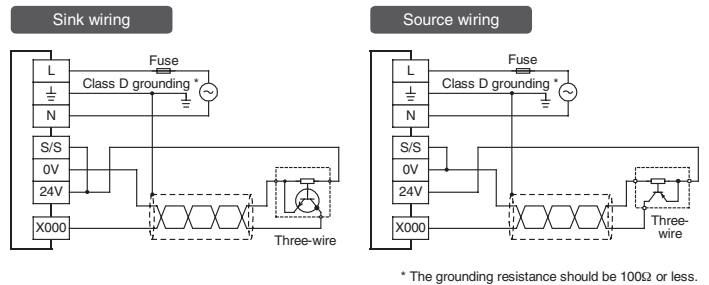

2) When 24VDC external power supply is used

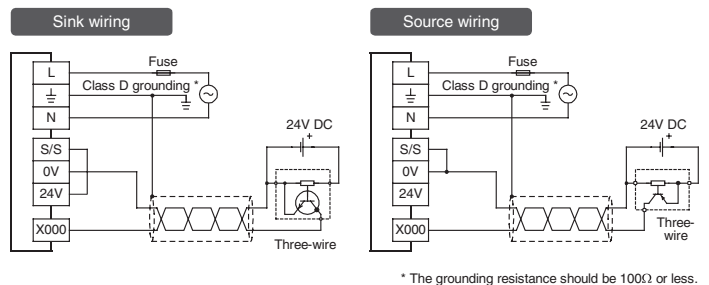

4.7 HIGH SPEED COUNTERS SPECIFICATIONS AND WIRING

High-speed counters use input terminals X000 to X007 of the main unit for inputs, and offer counting up to 60kHz (1 phase).

Input terminals not used for high-speed counters are available for general-purpose inputs.

For details on programming, refer to the HELP section of GX Works2.

■ EXAMPLES OF EXTERNAL WIRING (ROTARY ENCODER) 1-phase 1-input [C235 to C245]

The following examples of wiring apply to the cases where C235 is

used. When another high-speed counter number is used, wire the counter referring to the following diagrams. It is recommended to use shielded twisted-pair cables for connection cables. Ground the shield of each shielded cable only on the PLC side.

1) NPN open collector transistor output rotary encoder

In the case of sink wiring

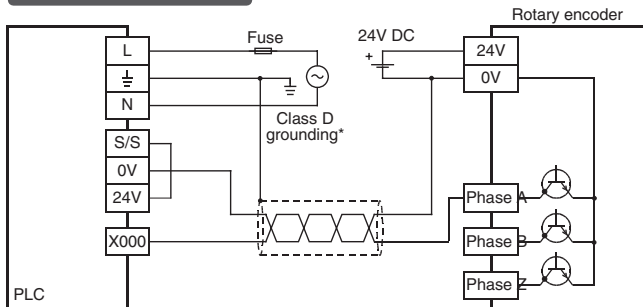

* The grounding resistance should be 100Ω or less.

2) PNP open collector transistor output rotary encoder

In the case of source wiring

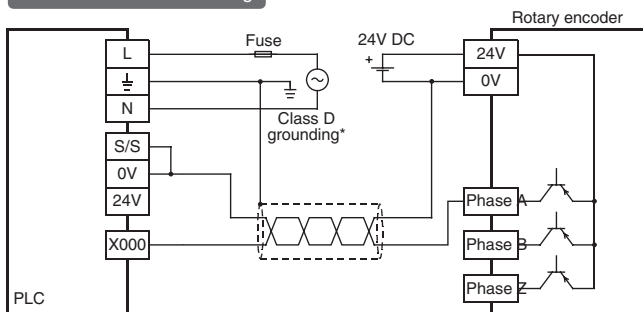

* The grounding resistance should be 100Ω or less.

2-phase 2-input [C251 to C255]

The following examples of wiring apply to the cases where C251 is used. When another high-speed counter number is used, wire the counter referring to the following diagrams.

It is recommended to use shielded twisted-pair cables for connection cables. Ground the shield of each shielded cable only on the PLC side.

1) NPN open collector transistor output rotary encoder

In the case of sink wiring

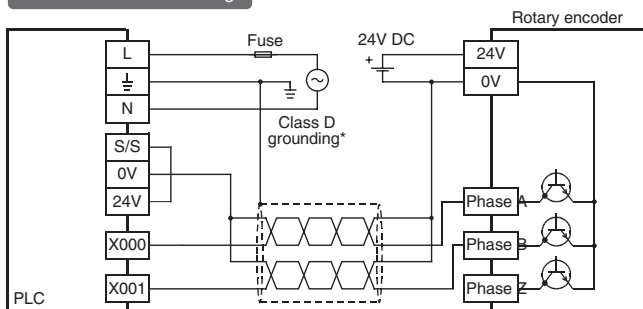

* The grounding resistance should be 100Ω or less.

2) PNP open collector transistor output rotary encoder

In the case of source wiring

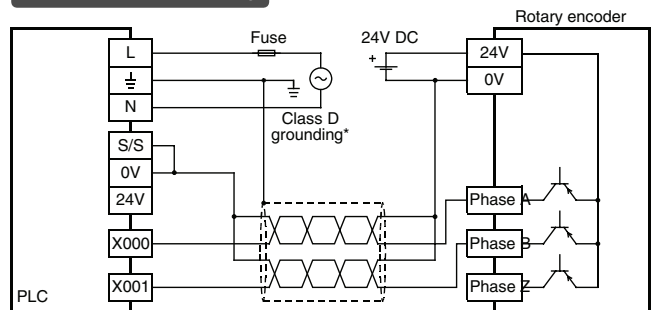

* The grounding resistance should be 100Ω or less.

4.8 OUTPUT SPECIFICATIONS AND WIRING

Item	FX3GE-24MR/ES	
Number of Output Points	10 points (16 points) *1	
Input Connecting Type	Terminal block (M3 screw)	
Output Form	Relay	
External Power Supply	30VDC or less 240VAC or less *2	
Max. Load	Resistance Load	2A/point *3
	Inductive Load	80VA
Minimum Load	5VDC, 2mA (reference value)	
Open Circuit Leakage Current	-	
Response Time	OFF-ON	Approx. 10ms
	ON-OFF	
Circuit Insulation	Mechanical insulation	
Display of Output Operation	LED lights when power is applied to relay coil	

- Each value inside () indicates the number of occupied points.
- Between 250V and 240V CE, UL, and cUL are not compliant.
- The total load current of resistance loads per common terminal should be the following value or less.
 - ▶ 1 output point/common terminal: 2A
 - ▶ 4 output points/common terminal: 8A

■ LIFE OF RELAY OUTPUT CONTACT

The product life of relay contacts considerably varies depending on the load type used. Take care that loads generating reverse electromotive force or rush current may cause poor contact or deposition of contacts which may lead to considerable reduction of the contact product life.

Inductive load Inductive loads generate large reverse electromotive force between contacts at shutdown may cause arcing. At a fixed current consumption, as the power factor (phase between current and voltage) gets smaller, the arc energy gets larger. The standard life of the contact used for Inductive loads, such as contactors and solenoid valves, is 500 thousand operations at 20VA.

The following table shows the approximate life of the relay based on the results of our operation life test.

Test condition: 1 sec. ON / 1 sec. OFF.

Load Capacity	Contact Life	
20VA	0.2A/100VAC	3 million times
	0.1A/200VAC	
35VA	0.35A/100VAC	1 million times
	0.17A/200VAC	
80VA	0.8A/100VAC	2 hundred thousand times
	0.4A/200VAC	

The product life of relay contacts becomes considerably shorter than the above conditions when the rush overcurrent is shut down. Some types of inductive loads generate rush current 5 to 15 times

the stationary current at activation. Make sure that the rush current does not exceed the current corresponding to the maximum specified resistance load.

Lamp load Lamp loads generally generate rush current 10 to 15 times the stationary current. Make sure that the rush current does not exceed the current corresponding to the maximum specified resistance load.

Capacitive load Capacitive loads can generate rush current 20 to 40 times the stationary current. Make sure that the rush current does not exceed the current corresponding to the maximum specified resistance load. Capacitive loads such as capacitors may be present in electronic circuit loads including inverters.

EXAMPLE OF RELAY OUTPUT WIRING

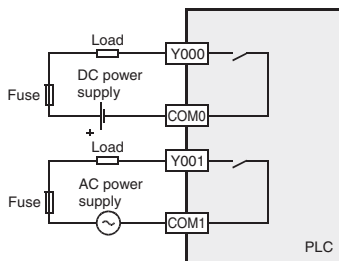

CAUTIONS IN EXTERNAL WIRING

Protection circuit for load short-circuiting

When a load connected to the output terminal short-circuits, the printed circuit board may be burnt out. Fit a protective fuse on the output circuit.

Protection circuit of contact when inductive load is used

An internal protection circuit for the relays is not provided for the relay output circuit in this product. It is recommended to use inductive loads with built-in protection circuits. When using loads without built-in protection circuits, insert an external contact protection circuit, etc. to reduce noise and extend the product life.

DC CIRCUIT Connect a diode in parallel with the load. Use a diode (for commutation) having the following specifications:

Item	Standard
Reverse Voltage	5 to 10 times the load voltage
Forward Current	Load current or more

AC CIRCUIT Connect the surge absorber (combined CR components such as a surge killer and spark killer, etc.) parallel to the load. Select the rated voltage of the surge absorber suitable to the output used. Refer to the table below for other specifications.

Item	Standard
Electrostatic Capacity	Approx. 0.1μF
Resistance Value	Approx. 100 to 200Ω

INTERLOCK Loads, such as contactors for normal and reverse rotations, that must not be turned on simultaneously should have an interlock in the PLC program and an external interlock.

COMMON MODE Use output contacts of the PLC in the common mode.

5. BUILT-IN ETHERNET

5.1 ETHERNET SPECIFICATIONS AND WIRING

CAUTION: DESIGN PRECAUTIONS

- Observe the following items. Failure to do so may cause incorrect datawriting through noise to the PLC and result in PLC failure, machine damage or other accident.
 - Do not bundle the control line together with or lay it close to the main circuit or power line. As a guideline, lay the control line at least 100mm (3.94") or more away from the main circuit or power line. Noise may cause malfunctions.
 - Ground the shield wire or shield of a shielded cable. Do not use common grounding with heavy electrical systems.

COMMUNICATION SPECIFICATIONS

Item	Specification	
Transmission Specifications	Data transmission speed	100Mbps/10Mbps
	Communication method	Full-duplex/Half-duplex
	Transmission method	Base band
	Maximum segment length	100m (328'1")

PERFORMANCE SPECIFICATIONS

Item	Specification
Functions	MELSOFT connections
	MELSOFT Direct Connection (Simple Connection)
	Diagnostics function from MELSOFT

CONNECTING TO THE NETWORK

The following explains how to connect the built-in Ethernet to 10BASE-T/100BASE-TX networks. Pay close attention to safety and use the built-in Ethernet properly.

Sufficient network knowledge and safety precautions are required when installing 10BASE-T or 100BASE-TX networks. Consult a specialist when connecting cable terminals or installing trunk line cables, etc.

Use a connection cable conforming to the standards shown in this manual.

CAUTIONS REGARDING POWERING THE HUB, PLC AND ETHERNET SIMULTANEOUSLY

On some hubs, for a fixed period of time immediately after powering up, even if packets are sent from the Ethernet device, there are cases when packets are not sent to the external device. In this case, create a sequence program that waits a sufficient amount of time after powering up before sending packets.

■ APPLICABLE CABLE AND CONNECTOR

Connector RJ45 type modular jack

Pin Configuration The pin sequence of the 10BASE-T/100BASE-TX connection connector (RJ45 type modular jack) of the built-in Ethernet is as follows:

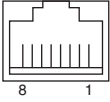

Pin No.	Signal	Direction	Contents
1	TD+	Out	+ side of sending data
2	TD-	Out -	side of sending data
3	RD+	In	+ side of receiving data
4	Not used	-	
5	Not used	-	
6	RD-	In	- side of receiving data
7	Not used	-	
8	Not used	-	

Applicable cable

10BASE-T	Cable conforming to Ethernet standard practice: Category 3 or higher (STP cable)
100BASE-TX	Cable conforming to Ethernet standard practice: Category 5 or higher (STP cable)

A straight cable is used. A cross cable can also be used when using direct connection (simple connection) between the personal computer and the FX3GE Series PLC.

■ CONNECTING TO THE 10BASE-T/100BASE-TX NETWORK

This section explains how to connect the built-in Ethernet to the 10BASE-T, 100BASE-TX network.

The following shows the connection diagram for the twisted pair cable.

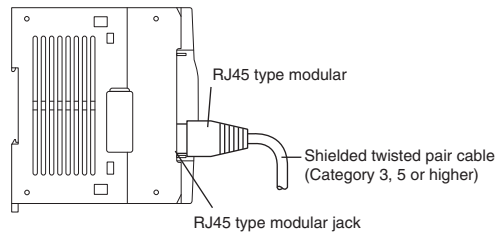

■ OPERATING PROCEDURE

1. Connect the twisted pair cable to the hub.
2. Connect the twisted pair cable to the built-in Ethernet.
 - ▶ The built-in Ethernet detects whether it is 10BASE-T or 100BASE-TX, and in full-duplex or half-duplex transmission mode automatically according to the hub. (Auto detection function) For connection to a hub without the auto detection function, set the half-duplex mode on the hub side.

5.2 PARAMETER SETTINGS AND DIAGNOSTICS IN GX WORKS2

This section explains operations of GX Works 2 related to the Ethernet adapter setting.

■ ETHERNET PORT SETTING

Set Ethernet adapter on the “Ethernet Port” tab of the “FX Parameter” screen in PLC parameters.

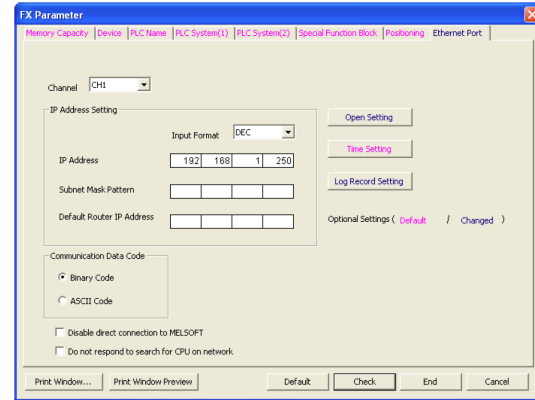

Setting	Description
Channel	Select whether or not the Ethernet adapter is connected. When it is connected, specify the channel connected to the Ethernet adapter. [Setting] • Not Set • CH1 • CH2
Input Format	Select the input format and display format used to set the IP address, subnet mask pattern and default router IP address. [Setting] • Decimal • Hexadecimal
IP Address *1	Set the Ethernet adapter IP address. [Setting range] • 0.0.0.1 to 223.255.255.254 (Decimal) • 00.00.00.01 to DF.FF.FF.FE (Hexadecimal)
Subnet Mask Pattern *1	Specify the subnet mask pattern. [Setting range] • 192.0.0.0 to 255.255.255.252 (Decimal) • C0.00.00.00 to FF.FF.FF.FC (Hexadecimal)
Default Router IP Address *1	Specify the IP address of the default router when it is used. [Setting range] • 0.0.0.1 to 223.255.255.254 (Decimal) • 00.00.00.01 to DF.FF.FF.FE (Hexadecimal)
Communication Data Code	Select the data code used for communication using the MC protocol • Binary Code Communicates by binary code • ASCII Code Communicates by ASCII code
Disable Direct Connection to MELSOFT	Set whether or not direct connection to MELSOFT is disabled.
Do Not Respond to Search for CPU on Network	MELSOFT connection to the search for connection CPU is disabled
Log Record Setting	A click of the button will display “Ethernet Port Log Record Setting” screen

*1 Set the IP address, subnet mask pattern and default router IP address upon consulting a network administrator.

LOG RECORD SETTING

On the “Log Record Setting” screen, set the error log save destination and others. The user device (D, R) is used to save the error log, etc. Click the [Log Record Setting] button on the “Ethernet Port” screen to display the screen below.

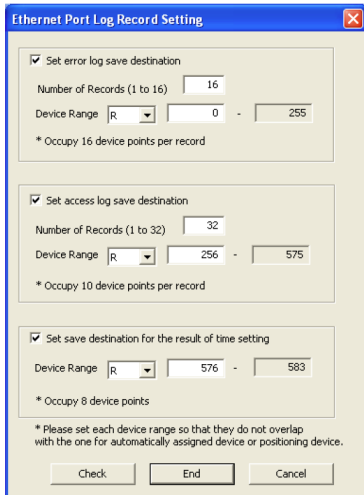

Setting		Description	
Set Error Log Save Destination		Error log is stored if checked	
Error Log	Number of Records	Specify the number of records in the error log within the range from 1 to 16. One record occupies devices 16 points	
	Device Range	Head Device Type	Select the device type of the error log save destination between “D” and “R”
		Head Device Number	Set the head device number of the error log save destination
		Last Device Number	The last device number in the occupied range calculated from the head device number and number of records is displayed
Set access Log Save Destination		Access log is stored if checked	
Access Log	Number of Records	Specify the number of records in the access log within the range from 1 to 32. One record occupies 10 points.	
	Device Range	Head Device Type	Select the device type of the access log save destination between “D” and “R”
		Head Device Number	Set the head device number of the access log save destination
		Last Device Number	The last device number in the occupied range calculated from the head device number and number of records is displayed
Set Save Destination for the Result of Time Setting		Result of time setting is stored if checked	
Save Destination for the Result of Time Setting (Device Range)	Head Device Type	Select the device type of the time setting result save destination between “D” and “R”	
	Head Device Number	Set the head device number of the time setting result save destination. 8 points are occupied from the head device number	
	Last Device Number	The last device number in the occupied range calculated from the head device number is displayed	

MELSOFT DIRECT CONNECTION (SIMPLE CONNECTION)

This function connects the main unit to a MELSOFT product (such as GX Works2) with one Ethernet cable without using the hub. The direct connection enables communication by only specifying the connection target. IP address setting is not required.



CAUTION

- When the item “Disable direct connection to MELSOFT” is checked in the Ethernet port setting of the PLC parameters, direct connection is disabled. Check this item to prevent illegal connections from remote places.
- When the Ethernet adapter is connected to the LAN line, do not set direct connection. It may increase the load on the line and adversely affect communication or other devices.
- Do not configure direct connection in a system configuration that connects the Ethernet adapter with an external device using a hub.
- When two or more Ethernet ports are enabled in the network connections setting on the personal computer, communication by direct connection is not possible. In the setting, leave only one Ethernet port enabled for direct connection and disable the other Ethernet ports.
- Under the following conditions, direct connection communication may not be available. In that case, check the setting of the Ethernet adapter, main unit and/or personal computer.
 - ▶ When all bits corresponding to “0” of the subnet mask in the personal computer are ON or OFF
 - ▶ When all bits corresponding to the host address in each class of IP address in the personal computer are ON or OFF
- When the FX3GE PLC (Ethernet adapter) is connected directly to the personal computer (MELSOFT direct connection), a communication error may occur when the PLC memory clear operation is executed due to the Windows firewall. In this case, open the Windows control panel, and specify the MELSOFT product (such as GX Works2) as “Allowed program” or “Exception” in the security setting for Windows firewall.

DESIGNATION OF DESTINATION TO BE CONNECTED

When the FX PLC is connected using the Ethernet adapter, the following route is used.

Personal Computer Side I/F	PLC Side I/F	Other Station Setting Network	Connection pathname / Imaged figure / Explanation
Ethernet	CPU (Direct connection)	No Specification	Direct connection of the PLC module for Ethernet board communication Personal computer is connected directly to the Ethernet adapter with the LAN cable. Connection of the PLC module via a hub for Ethernet board communication
			Ethernet (HUB) Personal computer is connected to the Ethernet adapter via a hub. This route supports the find CPU function.

TRANSFER SETUP SCREEN

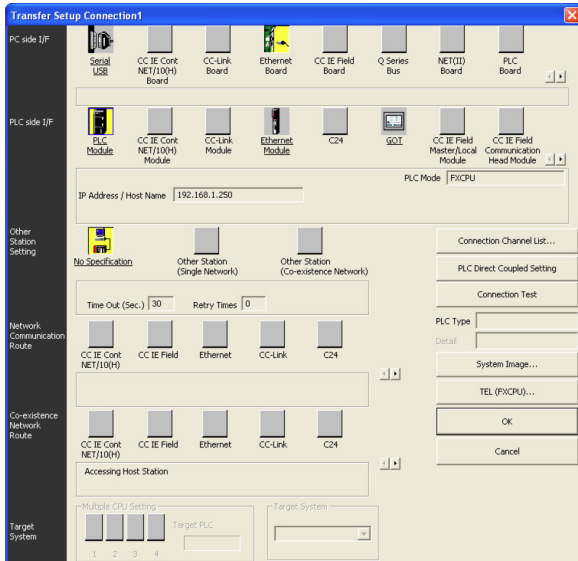

When connecting the FX PLC using the Ethernet adapter, set the following contents on the “Transfer Setup Connection” screen.

- PC side I/F
“Ethernet Board” is chosen.
- PLC side I/F
Double-click “PLC Module” to open the “PLC side I/F Detailed Setting of PLC Module” screen, and set details of the connection route. For description, refer to “2)” below.
- Other Station Setting
Double-click “No Specification”, and set the “Check at Communication Time” and “Retry Times”

2) PLC side I/F Detailed Setting of PLC Module screen
On the “PLC side I/F Detailed Setting of PLC Module” screen, set the connection type (direct connection to the Ethernet port or connection via a hub) and others. For connection via a hub, the method to directly enter the IP address and host name and the method to search for connected PLC units and select one from the list are available.

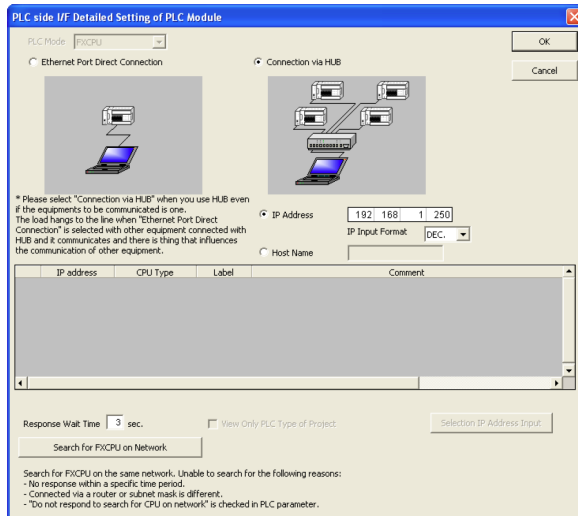

Setting	Description
PLC Mode	FXCPU is displayed
Ethernet Port Direct Connection *1	Check this item to select direct connection to the Ethernet port
Connection Via HUB *1	Check this item to select connection via a hub
IP Address *2	When the item “Connection via HUB” is checked, specify the IP address of the connection destination. To enter the IP address, there is another method to search for FXCPU units on the network and select one from the list of found FXCPU units.
Host Name *2	When the item “Connection via HUB” is checked, specify the host name of the connection destination
IP Input Format	Specify the input format used to set the IP address. [Setting] • DEC • HEX
Connection CPU List	This list shows the result of searching for FX PLC main units connected on the network. • IP address: Displays the IP address of a found PLC (in decimal). • CPU type: Displays the CPU type of a found PLC. • Label: Displays nothing because the FX PLC has no label. • Comment: Displays the PLC parameter, PLC name setting and title in up to 32 half-width characters. It is possible to select (by double-clicking) a desired FX PLC from the list to enter the IP address.
Response Wait Time	Specify the response wait time in the find CPU function. [Setting range] 0 to 99
View Only PLC Type of Project	Check this item so that only the CPU type selected in the project is displayed in the list of CPU units found on the network
Selection IP Address Input	Click this button to enter the IP address selected in the list of found CPU units to the “IP Address” input field

1. Only one can be selected between “Ethernet Port Direct Connection” and “Connection via HUB”.
2. Only one can be selected between “IP Address” and “Host Name”.

ETHERNET DIAGNOSTICS

The Ethernet diagnostics function checks various setting status in the Ethernet adapter.

Ethernet diagnostics function outline When the Ethernet adapter is used, the Ethernet diagnostics function monitors and tests the following items.

Function	Description
Parameter Status	IP address, Ethernet address, etc. are displayed
Error History	Connection No., Error code, Port number, Date, Time, etc. are displayed
Status of Each Connection (Access History)	• Status of each connection: Host station port No., Destination IP address, Destination port No., Latest error code, etc. are displayed. • Access History: Date, Time, Connection No., Destination IP address, etc. are displayed. (“Access History” is displayed together with “Status of each connection”)
Status of Each Protocol	TCP packet number and UDP packet number are displayed
Connection Status	Full Duplex/Half Duplex, Connection status and 10BASE-T/100BASE-TX are displayed
Time Setting Status	Latest time setting, Time required for response are displayed
PING Test	This test checks the presence of Ethernet modules on the Ethernet network whose initial processing is completed, or the presence of specified IP address

Ethernet diagnostics screen is displayed from the “Diagnostics” → “Ethernet Diagnostics” menu.

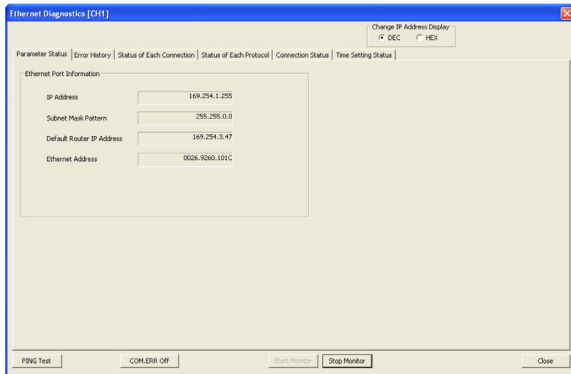

Function	Description
[Title Bar]	Ethernet Diagnostics [CH*] “[CH*]” indicates the channel being diagnosed (* = 1 or 2).
Change IP Address Display	Select the IP address notation on various tab screens between decimal and hexadecimal
Various Diagnostics Function Tabs	Each tab displays various information on the Ethernet adapter. Tabs are displayed in the following sequence. <ul style="list-style-type: none"> Parameter Status Error History Status of Each Connection Status of Each Protocol Connection Status Time Setting Status
PING Test	Click this button to execute the PING test to the external device
COM.ERR Off	Click this button to turn OFF the flickering of the [ERR.] LED in the Ethernet adapter
Start Monitor	Monitor is started
Stop Monitor	Monitor is stopped

Parameter status is monitored

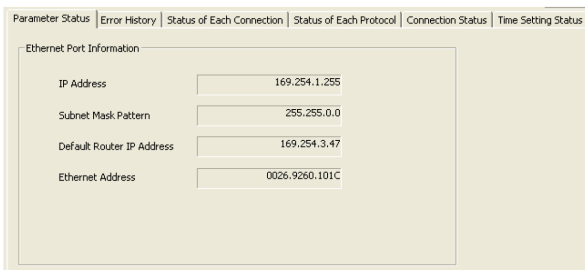

Function	Description
IP Address	IP address is displayed
Subnet Mask Pattern	Subnet mask pattern is displayed
Default Router IP Address	Default router IP address is displayed
Ethernet Address	Ethernet address is displayed. Display is only in hexadecimal

Error history is monitored: When “Set error log save destination” (area) in the PLC parameters is set to save ten records, only 10 lines become valid.

Connection No.	Protocol	Open System	Host Station Port No.	Error Code	Destination IP Address	Destination Port No.	Command Code	Year/Month/Day	Time
1			760	760				2013-03-25	15:54:46
2			760	760				2013-03-25	15:54:40
3			760	760				2013-03-25	15:49:12
4									
5									
6									
7									
8									
9									
10									
11									
12									
13									
14									
15									
16									

Function	Description
Connection No.	Connection number (1 to 4)
Protocol	Protocol is displayed
Open System	Open system is displayed
Host Station Port No.	Host station port No. is displayed in decimals
Error Code	Error code is displayed in decimals. The error code is stored to the error code D8417 [CH1], D8437 [CH2] of the Ethernet adapter. If multiple errors occur in CH1, the error code of the first error is stored to D8417. If multiple errors occur in CH2, the error code of the first error is stored to D8437.
Destination IP Address	The IP address of the external device (connection destination) connected when the error occurred is displayed
Destination Port No.	The port number of the external device (connection destination) connected when the error occurred is displayed in decimal
Year/Month/Day	Date when the error occurred is displayed
Time	Time when the error occurred is displayed
Clear History	Error history is cleared

CAUTION: The history cannot be displayed when log record setting is not set up in the PLC parameters. The history can be displayed for the number of records (1 to 16) set in the log record setting.

Status of each connection, Access History

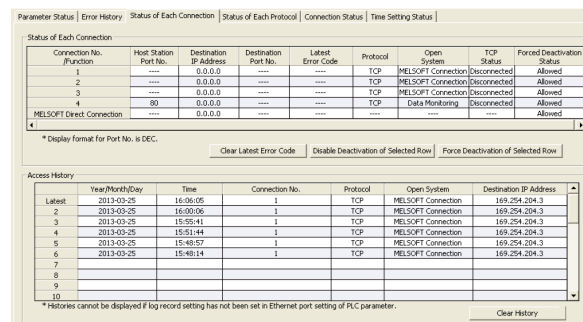

Function	Description
Connection No./Function	Connection No. and MELSOFT Direct Connection is displayed
Host Station Port No.	Host station port No. is displayed
Destination IP Address	Destination IP address is displayed
Destination Port No.	Destination port No. is displayed in decimal
Latest Error Code	Latest Error Code is displayed in decimal
Protocol	Protocol is displayed
Open System	Open system is displayed
TCP Status	The connection status is displayed when TCP protocol is selected
Forced Deactivation Status	Whether the forced deactivation status is allowed or rejected is displayed
Clear Latest Error Code	Latest Error Code is cleared
Disable Deactivation of Selected Row	This button cancels deactivation of the selected row
Force Deactivation of Selected Row	This button deactivates the selected row

CAUTION: While diagnosing Ethernet and when using data monitoring, MELSOFT connections opens/closes every time the display updates. Therefore, depending on the timing, it may not display the “TCP Status” as “Connecting.”

Item and description of access history

Function	Description
Year/Month/Day	Date when the error occurred is displayed
Time	Time when the error occurred is displayed
Connection No.	Connection No. (1 to 4) is displayed
Protocol	Protocol is displayed
Open System	Open system is displayed
Destination IP Address	Destination IP address is displayed
Clear History	Error history is cleared

CAUTION: The history cannot be displayed when log record setting is not set up in the PLC parameters. The history can be displayed for the number of records (1 to 32) set in the log record setting.

Even if connections are opened and closed repeatedly, the opening and closing history is not recorded. In MELSOFT connection, the date and time are logged as a new access when the TCP connection is established again after 10 seconds or more of no activity.

■ ERROR CODE LIST

This section explains the error codes (abnormal codes) for errors that may occur in each processing when communicating between the Ethernet adapter and an external device as well as those generated by processing requests from the local station's FX series PLC.

The error code is stored to the error code D8417 [CH1], D8437 [CH2] of the Ethernet adapter. If multiple errors occur in CH1, the error code of the first error is stored to D8417. If multiple errors occur in CH2, the error code of the first error is stored to D8437.

Error Code (Decimal)	Description	Corrective Action	ERR. LED
21	An error is detected in the PLC main unit	When an error has occurred in the PLC, take countermeasures in accordance with the contents of the error. • Replace the PLC and/or Ethernet adapter.	ON
22			
101	ROM error	<ul style="list-style-type: none"> • Check the connection status of connectors. • Check whether the Ethernet adapter is used within the general specification range. • Check whether the power capacity is sufficient. • Check whether the hardware is in normal status. • If a problem cannot be solved by the above actions, confirm the operation/communication status when the error occurred and the error log in the Ethernet adapter. Contact Mitsubishi Electric at Amzsupport@meau.com, and report the confirmed information. 	
102			
103			
104			
120	An error is detected in the PLC main unit.	When an error has occurred in the PLC, take countermeasures in accordance with the contents of the error.	

Error Code (Decimal)	Description	Corrective Action	ERR. LED
750	Sum error has occurred in a parameter	Set the parameter again, and start up the system again.	ON
751	The set value of a parameter is abnormal	Check the version of the Ethernet adapter, PLC main unit and MELSOFT.	
752			
753	The set value of the Ethernet adapter IP address is wrong	Correct the IP address. Set the class to "A" "B" or "C"	
756	The set value of the host station port No. is outside the allowable range when MELSOFT connection is specified. (Allowable range: 5556 only)	Correct the port No.	
761	The set value of the subnet mask field is outside the allowable range when the default router IP address is specified. (Allowable range: 192.0.0.0 to 255.255.255.252)	Correct the subnet mask	
762	The set value of the subnet mask field is wrong when the default router IP address is specified. ("1" does not continue from the first bit.)		
763	The set value of the default router IP address is wrong when the default router IP address is specified.	Correct the IP address. Set the class to "A" "B" or "C".	
764	The Ethernet adapter IP address and default router IP address do not belong to the same network address when the default router IP address is specified	Correct the IP address. Set the class to "A" "B" or "C".	
765	The Ethernet adapter IP address and external device IP address do not belong to the same network address when the default router IP address is not specified.	<ul style="list-style-type: none"> • Specify the default router IP address. • Correct the external device IP address. • Check whether the network address is correct. 	
771	The specified device type used to record the error log is outside the allowable range	Check the device type setting	
772	The set value of the number of records is outside the allowable range when the error log is recorded. (Allowable range: 1 to 16)	Check the number of records setting	
773	The set value of the head device is outside the allowable range when the error log is recorded	Check the device number setting	
774	The specified device type used to record the access log is outside the allowable range	Check the device type setting	
775	The set value of the number of records is outside the allowable range when the access log is recorded. (Allowable range: 1 to 32)	Check the number of records setting	
776	The set value of the head device is outside the allowable range when the access log is recorded	Check the device number setting	
777	The specified device type used to record the time setting result is outside the allowable range	Check the device type setting	

Error Code (Decimal)	Description	Corrective Action	ERR. LED
778	The set value of the head device is outside the allowable range when the time setting result is recorded	Check the device number setting	ON
779	The range of devices used to record various logs (error log, access log and time setting result) overlaps	Correct the number of records and device number of various logs (error log, access log and time setting result).	
780	The host station port No. setting is wrong. (For example, the same port No. is set for both the MC protocol and data monitoring, or when the data monitoring function is set as two or more connections with different port numbers specified, etc.)	Correct the port No.	
815	Sending is disabled because a cable is disconnected or defective (wire breakage).	Check whether cables are connected correctly. • Check the hub power supply.	Flicker
911	A receive error occurred in TCP/IP communication	<ul style="list-style-type: none"> Check operation of the external device. The line may be jammed with packets. Wait for a while, and execute sending again. Check whether cables are connected correctly. 	
912	A receive error occurred in UDP/IP communication	<ul style="list-style-type: none"> Check operation of the external device. The line may be jammed with packets. Wait for a while, and execute sending again. Check whether cables are connected correctly. 	
1013	A send error occurred in TCP/IP communication	<ul style="list-style-type: none"> Check operation of the external device. Check whether cables are connected correctly. 	
1014	send error occurred in UDP/IP communication	<ul style="list-style-type: none"> Check whether cables are connected correctly. 	
1015	Sending is disabled because a cable is disconnected or defective (wire breakage)	<ul style="list-style-type: none"> Check whether cables are connected correctly. Check the hub power supply. 	
1016	Sending is disabled because the communication line is closed	<ul style="list-style-type: none"> Check operation of the external device. Check whether cables are connected correctly 	
1117	The data length is beyond the allowable range	<ul style="list-style-type: none"> Correct the data length. When the send data exceeds the specified quantity, divide it and send divided portions one by one. 	
2417		<ul style="list-style-type: none"> The line may be jammed with packets. Wait for a while, and execute sending again 	
2550	Received ASCII code data cannot be converted into binary code when ASCII code communication is set in the operation setting in the Ethernet adapter	<ul style="list-style-type: none"> Set binary code communication in the operation setting, start up the Ethernet adapter again, and execute communication again. Correct the send data from the external device, and send the corrected data 	
2551	A specified device is wrong. (Unexpected device type.)	Correct the contents of request, and send the corrected contents to the Ethernet adapter	
2552	A specified device is wrong. (Read/write of bit unit to a non-bit device.)	Correct the contents of request, and send the corrected contents to the Ethernet adapter. (Correct a subcommand, etc.)	

Error Code (Decimal)	Description	Corrective Action	ERR. LED
2553	A specified device is wrong. (An odd number is specified for access to C200 to C255.)	Correct the contents of request, and send the corrected contents to the Ethernet adapter	Flicker
2554	A specified device is wrong. (The head device number is not a multiple of 16 when accessing bit devices in word units.)	Correct the contents of request, and send the corrected contents to the Ethernet adapter. (Correct a subcommand, etc.)	
2555	A specified device is wrong. (C200 to C255 are specified for word unit random write.)	Correct the contents of request, and send the corrected contents to the Ethernet adapter	
2556	The number of read/write points is outside the allowable range		
2557	The request for read/write exceeds the maximum address		
2558	A specified command or subcommand is wrong	<ul style="list-style-type: none"> Make the response monitoring timer value longer. Check whether the PLC is operating normally. 	
2559	A response was not received within the response monitoring timer value		
2560	The specified PLC number is wrong		
2650	HTTP request error	Check the HTTP version supported by the browser.	
10032	The Ethernet adapter was not able to receive the data sent from the external device.	The line may be jammed with packets. Contact the network manager, and mitigate the load applied on the line by separating the network or reducing the data quantity	
10035	The Ethernet adapter aborted message sending	Check the communication setting of the HUB	
10166	System error (Communication with the PLC main unit failed.)	<ul style="list-style-type: none"> Check the connection status of connectors. When an error has occurred in the PLC, take countermeasures in accordance with the contents of the error. Check the scan time in the PLC. Replace the PLC 	
10167			
10168			
10169			
10853			
12650			
20154			
20155			
20156			
20159			
20353			
20354			
20356			
20357			
20359			
20360			
20361			
20363			
20364			
20365			
20366			
20367			
20368			
20369			
20370			
20451			
20751			
20752			
20753			
20755			
20852			

Error Code (Decimal)	Description	Corrective Action	ERR. LED
20853	System error (Communication with the PLC main unit failed.)	<ul style="list-style-type: none"> Check the connection status of connectors. When an error has occurred in the PLC, take countermeasures in accordance with the contents of the error. Check the scan time in the PLC. Replace the PLC 	ON
20854			
20858			
20859			
21251			
21253			
21751			

STATUS OF EACH PROTOCOL

Number of communication packets is monitored

Item	Description	
TCP Packet	Total Number of Receives	Total number of TCP packets received is displayed
	Total Number of Sends	Total number of TCP packets sent is displayed
UDP Packet	Total Number of Receives	Total number of UDP packets received is displayed
	Total Number of Sends	Total number of UDP packets sent is displayed
Clear the Status of Each Protocol	Packet number displays cleared	

CONNECTION STATUS

Connection status (communicating status) is monitored

PING TEST

The PING test checks for the presence of Ethernet modules on the Ethernet network whose initial processing is completed, or the presence of specified IP address. Execute the PING test to the Ethernet adapter to confirm the following items.

- Whether the Ethernet adapter (test target) is connected correctly to the network.
- Whether parameters for the Ethernet adapter are set correctly.
- Whether initial processing for the Ethernet adapter is completed normally.

Communication route

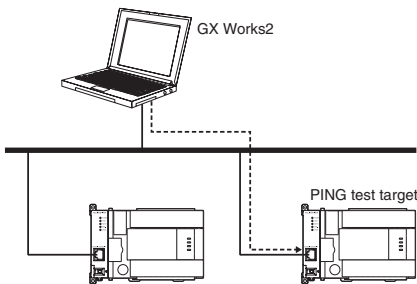

CAUTION The PING test supports only the communication route and does not support the communication route via the serial connection.

DISPLAY SCREEN

“Diagnostics” → “Ethernet Diagnostics” → “PING Test” button is clicked.

Item and description of the PING test screen

Item	Description		
Input item	Address Specification	IP Address	Set PING test target station IP address
		IP Address Input Format	Input format of the IP address and decimal/hexadecimal are chosen
		IP Address/Host Name	Set IP address or host name
	Setting Options	Display the Host Name	When this item is checked, the host name corresponding to the IP address is displayed in the “Result” field
		Specify the Data Size	Specify arbitrary size of the system data sent in the PING test. [Setting range] • 1 to 8192 byte (Default: 32 byte)
		Specify the Time of the Communication Time Check	The completed latency time of the PING test is specified. [Setting range] • 1 to 30 second (Default: 1 second)
		Specify the Number of Transmissions	Number of transmissions is specified. Or it executes until it is stopped. [Setting range] • 1 to 50 times (Default: 4 times)
		Default	Set default values to all settings in “Setting Options”
		Execute	PING test is executed
		Cancel	PING test is stopped
Result	Result	The result of the PING test is displayed	
	Success/Transmissions	The total number of times a packet was sent and number of times it was successful in the PING test are displayed	

ADDRESS SPECIFICATION

Specify the PING test target station using the IP address or host name.

- **When specifying the IP address**
Select the IP address input format (decimal or hexadecimal). Specify the IP address of the target station in accordance with the selected input format (decimal or hexadecimal).
- **When specifying the host name**
Specify the host name of the external device set in the “HOSTS” file in the personal computer where GX Works2 is installed or set in the DNS server. It is possible to enter the IP address in the “IP Address/Host Name” input field.

SETTING OPTIONS

Set details of the PING test. (It is not necessary to set this field when the initial value is used in each item.)

- **Display the host name**
Check this item when displaying the host name instead of the IP address of the PING test target station.

- **Specify the data size**
Specify the size of the system data sent in the PING test.
Setting range: 1 to 8192 byte (Default: 32 byte)
- **Specify the time of the communication time check**
Specify the time to wait for a response in the PING test.
Setting range: 1 to 30 second (Default: 1 second)
- **Specify the number of transmissions**
Specify the number of times the PING test is executed.

Function	Description
Specify the Number of Times	The PING test is executed the specified number of times. Setting range: 1 to 50 times (Default: 4 times)
Execute Till Interrupting	The PING test is executed repeatedly until the [Cancel] button is clicked

DESCRIPTION DETAILS OF THE RESULT COLUMN

1. Display of the PING test

- ▶ Description of the IP address specification display
Pinging [IP address] with [Set size] bytes of data:
- ▶ Example of IP address specification display
Pinging 192.168.0.3 with 32 bytes of data:
- ▶ Description of the host name specification display
Pinging [Host name [IP address]] with [Set size] bytes of data:
- ▶ Example of host name specification display
Pinging PLC1[192.168.0.3] with 32 bytes of data:

2. Description displayed on PING execution

- IP address
- Size of the received of the packet
- Round trip time of the packet
- Maximum lifespan of the packet
- ▶ Description of the completion display
Reply from [IP address]: bytes=[Set size] time<1ms
TTL=[Communication speed]
- ▶ Example of completion display
Reply from 10.97.29.75: bytes=32 time<1ms TTL=64
- ▶ Display when there is an error
Request timed out.

3. Description displayed on the reception end and the Cancel button click

- Total packet transmission count
- Success count
- Failure count
- Packet minimum round trip time
- Packet maximum round trip time
- Packet average round trip time

SUCCESS/TRANSMISSIONS

The number of times of success and total number of times of a packet was sent are updated every time 1 packet is sent.

6. BUILT-IN ANALOG SPECIFICATIONS AND WIRING

CAUTION WIRING PRECAUTIONS

- When drilling screw holes or wiring, make sure cutting or wire debris does not enter the ventilation slits. Failure to do so may cause fire, equipment failures or malfunctions.
- Make sure to observe the following precautions in order to prevent any damage to the machinery or accidents due to abnormal data written to the PLC under the influence of noise:
 1. Do not bundle the power line or shield of the analog input/output cable together with or lay it close to the maincircuit, high-voltage line, or load line. Otherwise, noise disturbance and/or surge induction are likely to take place. As a guideline, lay the control line at least 100mm (3.94") or more away from the main circuit, high-voltage line, or load line.
 2. Ground the shield of the analog input/output cable at one point on the signal receiving side. However, do not use common grounding with heavy electrical systems.
- Make sure to properly wire to the terminal block (European type) in accordance with the following precautions. Failure to do so may cause electric shock, equipment failures, a short-circuit, wire breakage, malfunctions, or damage to the product.
 - ▶ The disposal size of the cable end should follow the dimensions described in the manual.
 - ▶ Tightening torque should follow the specifications in the manual.
 - ▶ Twist the end of strand wire and make sure that there are no loose wires.
 - ▶ Do not solder-plate the electric wire ends.
 - ▶ Do not connect more than the specified number of wires or electric wires of unspecified size.
 - ▶ Affix the electric wires so that neither the terminal block nor the connected parts are directly stressed.

6.1 ANALOG INPUT TERMINAL BLOCK (EUROPEAN TYPE)

1. Wire size
Wiring to analog device should use 22-20 AWG wire.
2. Applicable cable
Analog input performance specifications

Model Names	Wire Size
Single Wire	0.3mm ² to 0.5mm ² (AWG22 to 20)
Double Wire	0.3mm ² (AWG22) × 2

3. Termination

Strip the coating of strand wire and twist the cable core before connecting it, or strip the coating of single wire before connecting it. An alternative connection is to use a ferrule with insulating sleeve.

Manufacturer	Model	Caulking Tool
Phoenix Contact Co., Ltd.	AI 0.5-8WH	CRIMPFOX 6*1 (or CRIMPFOX 6T-F*2)

*1 Old model name: CRIMPFOX ZA 3

*2 Old model name: CRIMPFOX UD 6

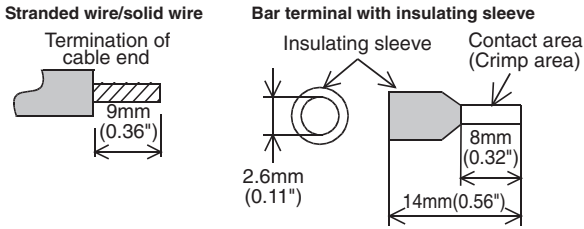

When using a stick terminal with an insulating sleeve, choose a wire with proper cable sheath referring to the above outside dimensions, otherwise the wire cannot be inserted easily.

Tighten the screws to a torque of 0.22 to 0.25 N•m. Do not tighten terminal screws exceeding the specified torque. Failure to do so may cause equipment failures or malfunctions.

4. Tool

For tightening the terminal, use a commercially available small screwdriver having a straight form that is not widened toward the end as shown below.

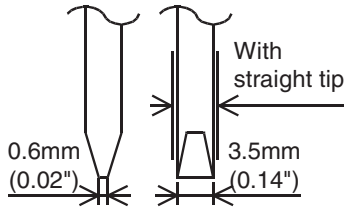

Note:
If the diameter of screwdriver grip is too small, tightening torque will not be able to be achieved. To achieve the appropriate tightening torque shown in the table above, use the following screwdriver or appropriate replacement (grip diameter : approximately 25mm (0.98")).

Manufacturer	Model Name
Phoenix Contact Co., Ltd.	SZS 0.6 x 3.5

ANALOG INPUT PERFORMANCE SPECIFICATIONS

Item	Voltage Input	Current Input
Analog Input Range	0V to 10VDC (Input resistance: 198.7kΩ)	4mA to 20mA DC (Input resistance: 250Ω)
Absolute Maximum Input	-0.5V,+15V	-2mA,+30mA
Resolution	2.5mV(10V/4000)	5μA(16mA/3200)
Overall Accuracy	<ul style="list-style-type: none"> ±0.5% (±50mV) for 10V full scale (when ambient temperature is 25°C ± 5°C) ±1.0% (±100mV) for 10V full scale (when ambient temperature is 0°C to 55°C) 	<ul style="list-style-type: none"> ±0.5% (±80μA) for 16mA full scale (when ambient temperature is 25°C ± 5°C) ±1.0% (±160μA) for 16mA full scale (when ambient temperature is 0°C to 55°C)
Input Characteristics		

ANALOG OUTPUT PERFORMANCE SPECIFICATIONS

Item	Voltage Output	Current Output
Analog Output Range	0V to 10V DC (External load: 2k to 1MΩ)	4mA to 20mA DC (External load: 500Ω or less)
Resolution	2.5mV(10V/4000)	4μA(16mA/4000)
Overall Accuracy	<ul style="list-style-type: none"> ±0.5% (±50mV) for 10V full scale (when ambient temperature is 25°C ± 5°C) ±1.0% (±100mV) for 10V full scale (when ambient temperature is 0°C to 55°C) Shipment adjustment is carried out by external load resistance 2kΩ. If external load resistance becomes larger than 2kΩ, the output voltage will increase slightly. When the load is 1MΩ, the output voltage becomes about 2% higher than the correct value 	<ul style="list-style-type: none"> ±0.5% (±80μA) for 16mA full scale (when ambient temperature is 25°C ± 5°C) ±1.0% (±160μA) for 16mA full scale (when ambient temperature is 0°C to 55°C)
Output Characteristics	0 to 4000 are adjusted to 0 to 10V when the external load resistance is 2kΩ.	0 to 4000 are adjusted to 4 to 20mA when the external load resistance is 250Ω.

CAUTION: In the voltage output characteristics, an area of dead band is located in the region of 0V. Therefore the output analog value may not represent the digital value accurately.

COMMON SPECIFICATIONS OF ANALOG INPUT AND OUTPUT

Setting	Description
Digital Input and Output	12 bits, binary
Conversion Time	90μs for each selected input channel + 50μs for each selected output channel (The data will be updated at every scan of the PLC.)
Insulation Method	No insulation between each channel or the PLC.
Occupied Points	0 point (This number is not related to the maximum number of input and output points of the PLC.)

EXAMPLE OF ANALOG INPUT

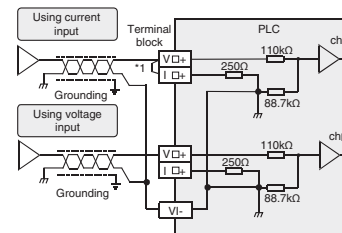

V□+, I□+, ch□: represents the channel number.
*1 Make sure to short-circuit the 'V□+' and 'I□+' terminals when current is input. (□: input channel number)

EXAMPLE OF ANALOG OUTPUT

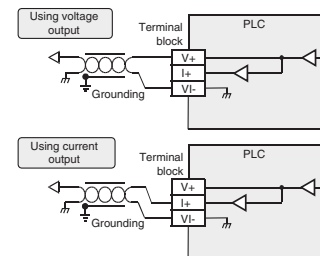

CAUTIONS IN WIRING:

1. Use 2-core shielded twisted pair cable for the analog output lines, and separate the analog output lines from other power lines or inductive lines.
2. The grounding resistance should be 100Ω or less.

LIST OF SPECIAL DEVICES

Special auxiliary relay	M8280	Switches the input mode of channel 1 OFF: Voltage input ON: Current input	R/W
	M8281	Switches the input mode of channel 2 OFF: Voltage input ON: Current input	R/W
	M8282	Switches the output mode OFF: Voltage output ON: Current output	R/W
	M8283 to M8285	Unused (Do not use.)	-
	M8286	Sets the cancel of output holding function. OFF: Holds the analog data output just before stop of the PLC. ON: Outputs the offset data at stop of the PLC.	R/W
	M8287	Sets whether or not input channel 1 is used. OFF: Channel is used. ON: Channel is not used.	R/W
	M8288	Sets whether or not input channel 2 is used. OFF: Channel is used. ON: Channel is not used.	R/W
	M8289	Sets whether or not output channel is used. OFF: Channel is used. ON: Channel is not used.	R/W
Special data register	D8280	Channel-1 input data	R
	D8281	Channel-2 input data	R
	D8282	Output setting data	R/W
	D8283	Unused (Do not use)	-
	D8284	Averaging time for channel-1 (Setting range: 1 to 4095)	R/W
	D8285	Averaging time for channel-2 (Setting range: 1 to 4095)	R/W
	D8286	Unused (Do not use)	-
	D8287	Unused (Do not use)	-
	D8288	Error status b0: Channel-1 over-scale detection b1: Channel-2 over-scale detection b2: Output data setting error b3: Unused b4: EEPROM error b5: Averaging time setting error b6: Hardware error b7: Communication data error b8 to b15: Unused	R/W
	D8289	Model code = 51	R

ANALOG ERROR STATUS DETAILS AND TROUBLESHOOTING

Error Status	Name	Description	Remedy
b0, b1	Over-scale detection	The input analog value (voltage or current value) is outside the specified range. Voltage input mode: The input voltage value is over the specified upper limit of 10.2 V. Current input mode: The input current value is over the specified upper limit of 20.4 mA.	Check that the input analog value is within the specified range. Also check the wiring.
b2	Output data setting error	The specified digital value is outside the specified range. Analog data will not be correctly output	Check that the specified digital value is within the specified range.
b4	EEPROM error	The adjustment data which was set in the EEPROM before delivery from our factory cannot be read out properly or has been destroyed	Please contact Mitsubishi Electric at Amzsupport@meau.com.
b5	Averaging time setting error	The averaging time set for one of the channels (channels 1 to 2) is outside the specified range: 1 to 4095	Check that the averaging time is set correctly for each channel.
b8, b9	Under-scale detection	The input analog value (current value) is below the specified lower limit. This error is only detected for the current input mode, and indicates the input current is less than 2 mA.	Check that the input analog value is within the specified range. Also check the wiring.

7. PROGRAMMING USING GX WORKS2

The software package GX Works2 is a programming tool designed to be used with FX3GE programmable controller. GX Works2 runs on Microsoft® Windows® 95, Windows® 98, Windows® Me, WindowsNT® Workstation 4.0, Windows® 2000, Windows® XP, Windows Vista®, Windows® 7, and Windows® 8 (hereafter referred to collectively as Windows®). The software has been designed to be both powerful and user friendly. While many of the software features can be learned intuitively, a detailed help file has been incorporated into the software to assist users in finding answers to their questions.

7.1 SYSTEM CONFIGURATION

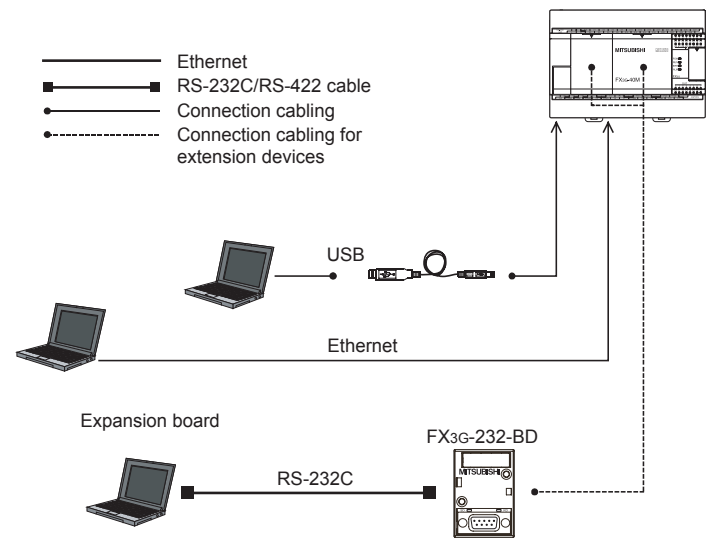

7.2 INSTALLING THE USB DRIVER

In order to communicate with a programmable controller CPU via USB, a USB driver needs to be installed.

The following explains the procedure of USB driver installation.

WHEN USING WINDOWS® 2000 PROFESSIONAL

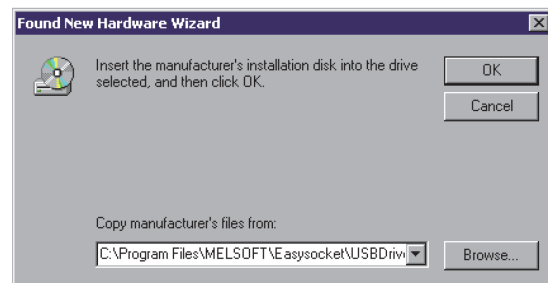

OPERATING PROCEDURE

1. Connect the personal computer and the programmable controller CPU with a USB cable, and then turn on the programmable controller CPU.
2. The *Found New Hardware Wizard* screen is displayed. Select "Specify a location".

- Click the **BROWSE** button and set “Easysocket\USBdrivers” in the folder where GX Works2 has been installed to “Copy manufacturer’s files from:”, and then click the **OK** button. If multiple MELSOFT products are installed previously, refer to their installed location.

POINT

Considerations when installing USB driver:

If the USB driver cannot be installed, confirm the following Windows® settings.

- If “Block → Prevent installation of unsigned files” is selected under [Control Panel] → [System] → [Hardware] → [Driver Subscription], the USB driver may not be installed.
- Select “Ignore → Install all files, regardless of file signature,” or “Warn → Display a message before installing an unsigned files” in [Driver Subscription], and execute the USB driver installation.

WHEN USING WINDOWS® XP

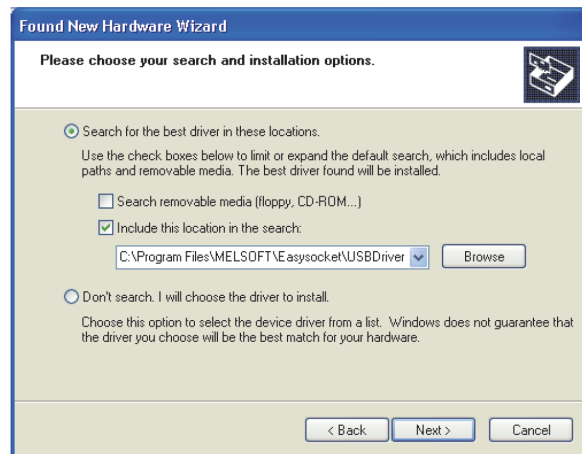

OPERATING PROCEDURE

- Connect the personal computer and the programmable controller CPU with a USB cable, and then turn on the programmable controller CPU.
- The Found New Hardware Wizard screen is displayed. Select “Install from a list or specific location (Advanced)”.
- Select “Search for the best driver in these locations” on the displayed screen. Select “Include this location in the search,” and then set “Easysocket\USBdrivers” in the folder where GX Works2 has been installed. If multiple MELSOFT products are installed previously, refer to their installed location.

POINT

Considerations when installing USB driver:

If the USB driver cannot be installed, confirm the following Windows® settings.

- If “Block - Never install unsigned driver software” is selected under [Control Panel] → [System] → [Hardware] → [Driver Signing], the USB driver may not be installed.
- Select “Ignore → Install the software anyway and don’t ask for my approval,” or “Warn → Prompt me each time to choose an action” in [Driver Signing], and execute the USB driver installation.

WHEN USING WINDOWS VISTA®

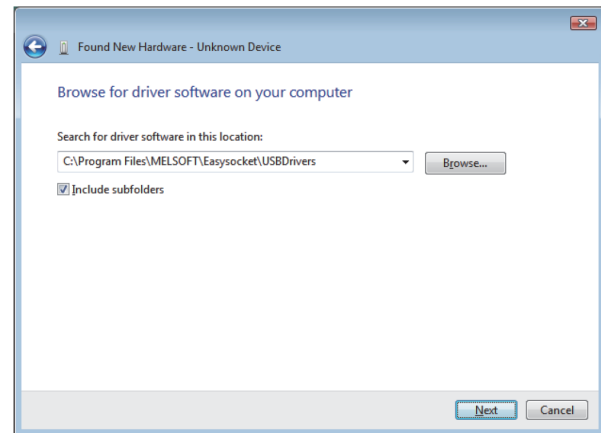

OPERATING PROCEDURE

- Connect the personal computer and the programmable controller CPU with a USB cable, and then turn on the programmable controller CPU.
- The *Found New Hardware* screen is displayed. Select “Locate and install driver software (recommended)”.
- Select “Browse my computer for driver software (advanced)” on the Found New Hardware screen.
- Specify “Easysocket\USBdrivers” in the folder where GX Works2 has been installed on the displayed screen. If multiple MELSOFT products are installed previously, refer to their installed location. Select “Include subfolders”.

POINT

Considerations when installing USB driver:

When the *Windows can't verify the publisher of this driver software* screen is displayed during the installation, select “Install this driver software anyway”.

WHEN USING WINDOWS® 7

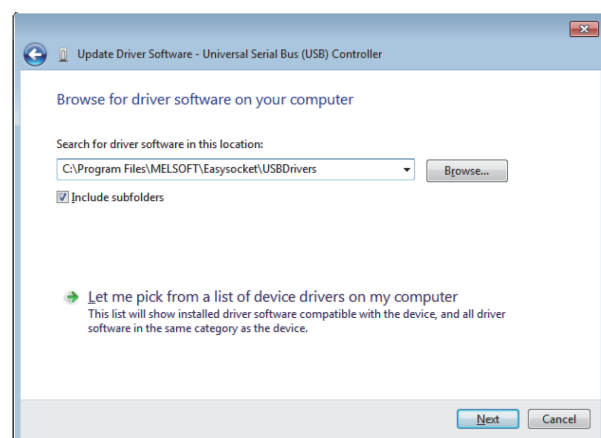

OPERATING PROCEDURE

- Connect the personal computer and the programmable controller CPU with a USB cable, and then turn on the programmable controller CPU.
- From Windows® Control Panel, select [System and Security] → [Device Manager]. Right-click “Unknown device” and click “Update Driver Software”.

- The Update Driver Software screen is displayed. Select “Browse my computer for driver software” and specify “Easysocket\USBdrivers” in the folder where GX Works2 has been installed on the displayed screen. If multiple MELSOFT products are installed previously, refer to their installed location.

WHEN USING WINDOWS® 8 OR WINDOWS® 8.1

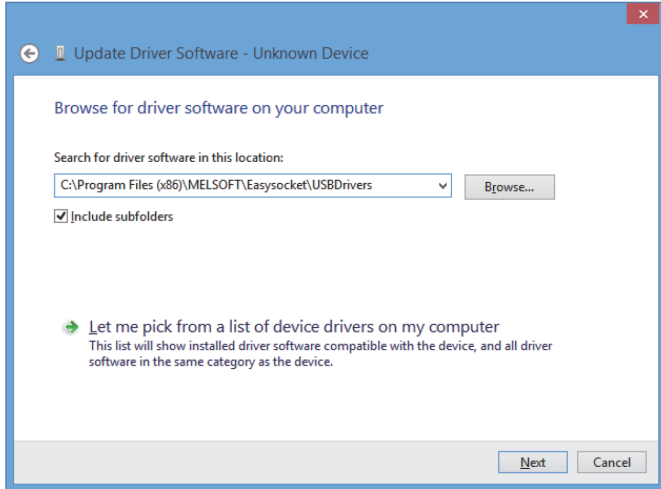

OPERATING PROCEDURE

- Connect the personal computer and the programmable controller CPU with a USB cable, and then turn on the programmable controller CPU.
- From Windows® Control Panel, select [System and Security] → [Device Manager]. Right-click “Unknown device” and click “Update Driver Software”.
- The Update Driver Software screen is displayed. Select “Browse my computer for driver software” and specify “Easysocket\USBdrivers” in the folder where GX Works2 has been installed on the displayed screen. If multiple MELSOFT products are installed previously, refer to their installed location.

7.3 INSTALLING GX WORKS2

This section explains how to install and uninstall GX Works2 (SW1DNC-GXW2-E). Please read carefully before installing the product to your personal computer.

Notice: Reprinting or reproducing the part or all of the contents of this document in any form for any purpose without the permission of Mitsubishi Electric Corporation is strictly forbidden.

- Although we have made the utmost effort to follow the revisions of the software and hardware, in some cases, unsynchronized matter may occur.

The information in this document may be subject to change without notice.

■ INSTALLATION

Install GX Works2 to the personal computer.

Confirm before installation

- Log on to the personal computer as an administrator.
- Close all the applications running under Microsoft® Windows® Operating System before installation. If the product is installed while other applications are running, it may not operate normally.

- Insert the CD-ROM (Disc 1) to the CD-ROM drive. Double click the “setup.exe” file on the CD-ROM (Disc 1).
- Following the on-screen instructions, select or enter the necessary information.

POINT

Product ID is written on the “License certificate” included with the product. Enter the 12-digit number divided into 3 and 9 digits.

■ OPERATING ENVIRONMENT

Item	Contents
Personal Computer	Windows® supported personal computer
CPU	Intel®Core™2 Duo Processor 2GHz or more recommended
Required Memory	1GB or more recommended
Available Hard Disk Capacity	When installing GX Works2: HDD available capacity is 2.5GB or more. When operating GX Works2: Virtual memory available capacity is 512MB or more.
Disk Drive	CD-ROM supported disk drive
Monitor	Resolution 1024 x 768 pixels or higher
OS (English Version)	Microsoft® Windows® 8.1 Operating System Microsoft® Windows® 8.1 Pro Operating System Microsoft® Windows® 8.1 Enterprise Operating System Microsoft® Windows® 8 Operating System Microsoft® Windows® 8 Pro Operating System Microsoft® Windows® 8 Enterprise Operating System Microsoft® Windows® 7 Starter Operating System Microsoft® Windows® 7 Home Premium Operating System Microsoft® Windows® 7 Professional Operating System Microsoft® Windows® 7 Ultimate Operating System Microsoft® Windows® 7 Enterprise Operating System Microsoft® Windows Vista® Home Basic Operating System *1 Microsoft® Windows Vista® Home Premium Operating System *1 Microsoft® Windows Vista® Business Operating System *1 Microsoft® Windows Vista® Ultimate Operating System *1 Microsoft® Windows Vista® Enterprise Operating System *1 Microsoft® Windows® XP Professional, Service Pack 2 or later *1 Microsoft® Windows® XP Home Edition, Service Pack 2 or later Microsoft® Windows® 2000 Professional, Service Pack 4 or later
Communication Interface *2	RS-232 port USB port Ethernet port

- 64-bit version is not supported.
- When a programmable controller CPU is directly connected.

PRECAUTIONS

- If .NET Framework 2.0 and Windows Installer 3.0 are not installed to the personal computer to which GX Works2 is to be installed, approximately 350MB of memory is required in the system drive to install them.
- For Windows® 8 and Windows® 8.1, if .NET Framework 3.5 (including .NET 2.0 and 3.0) is invalid on the personal computer to which GX Works2 is to be installed, it needs to be valid.
- The following functions cannot be used when the computer is running under Windows® XP, Windows Vista®, Windows® 7, Windows® 8, or Windows® 8.1. This product may not perform properly, when these functions are used.
 - Activating the application with Windows® compatible mode.
 - Simplified user switch-over
 - Remote desktop
 - Large font size (Advanced setting of Display Properties)
 - DPI setting other than 100% (set the size of text and illustration other than [smaller-100%])
 - Windows XP Mode

- Windows Touch or Touch
- Modern UI
- Client Hyper-V
- Use the product as a user having a privilege higher than ‘Standard user’ or ‘Administrator’ for Windows Vista®, Windows® 7, Windows® 8, and Windows® 8.1.
- The screens of this product may not perform properly when multi-display is set on Display Properties.
- For a personal computer with less than 1GB of memory, the startup speed of GX Works2 may be improved by increasing the memory to more than 1GB.
- The operations on the screen of this product may not be executed properly when the screen resolution is changed while the product is being activated.

7.4 STARTING AND EXITING GX WORKS2

Starting GX Works2

Select [Start] → [All Programs] → [MELSOFT Application] → [GX Works2] → [GX Works2].

Exiting GX Works2

Select [Project] → [Exit].

MAIN FRAME CONFIGURATION

The following screen shows a main frame configuration on which a work window and docked windows are displayed.

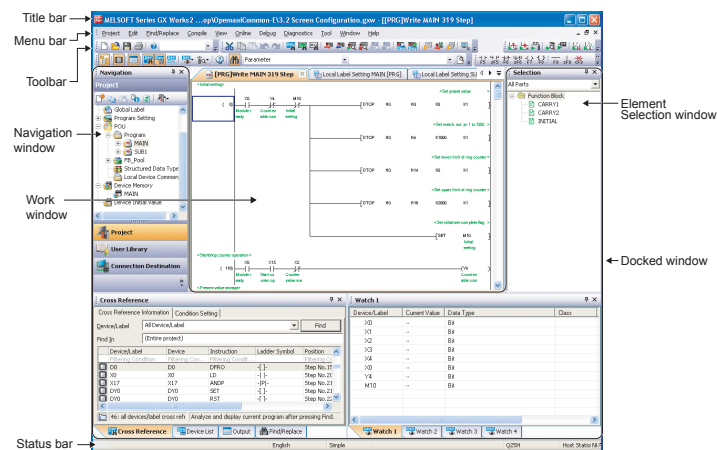

Name	Description
Title Bar	Display a project name
Menu Bar	Display menu options for executing each function
Toolbar	Display tool buttons for executing each function
Work window	A main screen used for operations such as programming, parameter setting, and monitoring
Docking window	A sub screen to support operations performed on a work window
Navigation	Display contents of a project in tree format
Element Selection	Display a list of functions (such as function blocks) used for programming
Output	Display compilation and check results (errors and warnings)
Cross Reference	Display cross reference results
Device List	Display the device list
Watch 1 to 4	A screen used for monitoring and changing current device values.
Intelligent Function Module Monitor 1 to 10	Screens used for monitoring intelligent function modules
Find/Replace	A screen used for searching and replacing character strings in the project
Debug	A screen used for setting the debug which uses the simulation function
Status bar	Display information about a project being edited

POINT

Focus point indication in Windows Vista®, Windows® 7, Windows® 8, or Windows® 8.1. When using Windows Vista®, Windows® 7, Windows® 8, or Windows® 8.1, the focus point may not be indicated on the screen.

To display the focus point, set the following setting.

1. For Windows Vista®, select [Start] → [Control Panel] → [Ease of Access] → [Ease of Access Center].
For Windows® 7, select [Start] → [Control Panel] → [Ease of Access] → [Ease of Access Center].
For Windows® 8 and Windows® 8.1, select the windows key + [X] [Control Panel] → [Ease of Access Center].
2. Select “Make the keyboard easier to use”
3. Select “Underline keyboard shortcuts and access keys”

7.5 USING THE HELP FILES IN GX WORKS2

Use the GX Works2 help function to learn GX Works2 operations, understand functions, and check error codes of programmable controller CPU.

The following items can be checked with the GX Works2 help function.

- Help for operations
- Help for instructions
- Help for special relays/special registers
- Help for CPU errors
- Error codes for CPU module communication
- Changes from GX Developer
- List of shortcut keys
- Registered Trademarks and Trademarks
- FX manuals

8. OPERATION

■ PRELIMINARY INSPECTION [POWER OFF]

Incorrect connection of the power supply terminal, contact of the DC input wire and power supply wire, or short-circuiting of output wires may result in serious damage. Before applying power, check that the power supply and ground terminals are connected correctly and input/output devices are wired properly.

NOTES The dielectric withstand voltage and insulation resistance test of the PLC should be measured in accordance with the following procedures.

1. Remove all input/output wires and power supply wires from the PLC.
2. Connect a crossing wire to each of the PLC terminals (power supply terminal, input terminals and output terminals) except the ground terminal.
3. For the dielectric withstand voltage test of each terminal, refer to the generic specifications for the product.
Measure the dielectric withstand voltage and insulation resistance between each terminal and the ground terminal. Dielectric withstand voltage: 1.5kV AC or 500V for 1min (The terminals vary in dielectric withstand voltage.) Insulation resistance: 500V DC/5M or more.

■ CONNECTION TO BUILT-IN PROGRAMMING CONNECTOR (RS-422)

• When connecting a peripheral device

Connect and disconnect the communication cable for the peripheral device. At connection, align the "positioning mark" between the cable and the main unit.

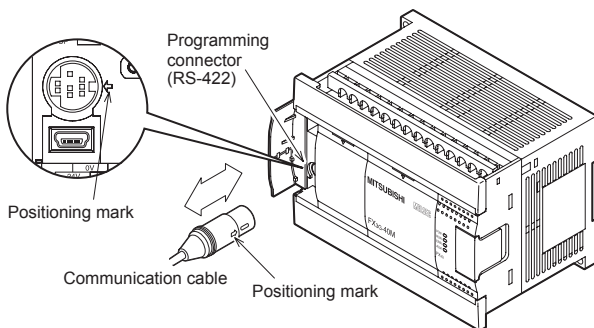

■ FOR CONTINUOUS USE OF A PERIPHERAL DEVICE (SUCH AS GOT)

- Cut off the area shown in the left figure below of the peripheral device connector cover (main unit) using a nipper, etc., and connect the peripheral device as shown in the right figure below.

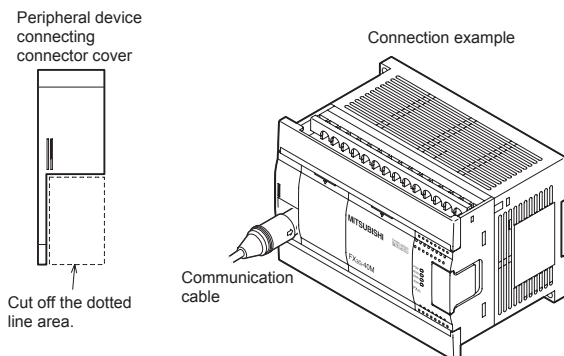

■ CONNECTION TO BUILT-IN PROGRAMMING CONNECTOR (USB)

Connect and disconnect the communication cable for the peripheral device (personal computer). At connection, confirm the cable and connector shape.

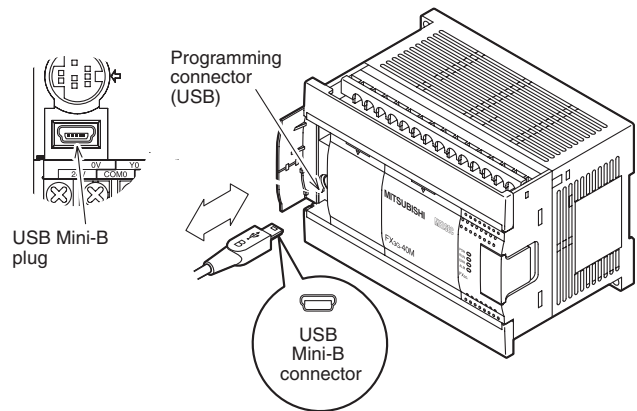

■ WRITING OF PROGRAM AND PROGRAM CHECK [POWER ON AND PLC STOPPED]

1. Turn on the PLC power.
Make sure that the RUN/STOP switch of the PLC is set to STOP, and turn the power on.
2. Check the program.
Check for circuit errors and grammatical errors with the program check function of the programming tool.
3. Transfer the sequence program.
Write the program to the PLC with the programming tool.
4. Verify the sequence program.
Verify that the program has been correctly written to the PLC.
5. Execute PLC diagnosis.
Check for errors in the PLC main body with the PLC diagnostic function of the programming tool.

■ METHODS OF RUNNING AND STOPPING

FX3GE PLCs can be started or stopped by any of the following three methods. Two of the methods can be combined. The RUN/STOP switch is located under the peripheral device connector cover.

1. Operation with built-in RUN/STOP switch

Operate the RUN/STOP switch on the front panel of the main unit to start and stop the PLC (refer to the right figure). Turn the switch to RUN, and the PLC will start. Turn it to STOP, and the PLC will stop.

RUN/STOP switch

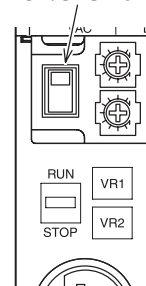

2. Running and stopping with general-purpose input (RUN terminal)

Operation with one switch (RUN)

One of the input terminals X000 to X017 *1 of the main unit can be used as a RUN input terminal by a parameter setting (refer to the figure below). When the specified input terminal is turned on, the PLC starts. When it is turned off, the PLC is started or stopped depending on the state of the built-in RUN/STOP switch.

*1. X000 to X007 in 14-point type main units, and X000 to X015 in 24-point type main units.

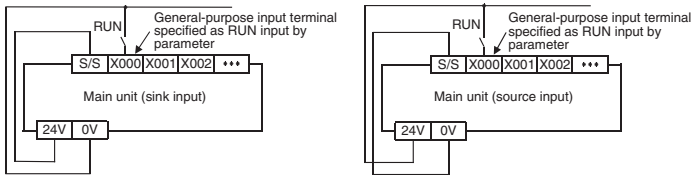

For details, refer to the HELP menu in GX Works2.

Operation with two switches (RUN and STOP)

The PLC can be started and stopped with individual RUN and STOP pushbutton switches. For this operation, a sequence program using M8035 to M8037 is necessary.

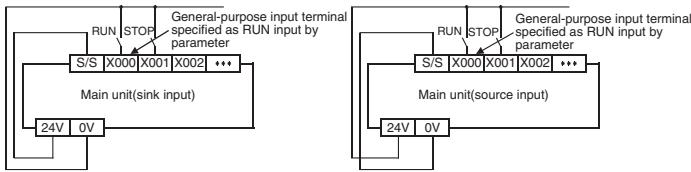

For details, refer to the HELP menu in GX Works2.

3. Starting and stopping by remote control from programming software

The programming software has a function to forcibly start and stop the PLC by remote control (remote RUN/STOP function). However, when power is reapplied, the remote RUN/STOP function is disabled. The RUN/STOP status is then determined by the RUN/STOP switch or RUN terminal.

For details on the start and stop procedures with remote control from programming software, see below.

■ USE OF SEVERAL RUNNING/STOPPING METHODS

1. When the built-in RUN/STOP switch and the general-purpose RUN terminal are used

(without remote running/stopping operation from the programming software) The RUN/STOP status of the PLC is determined by the conditions shown in the following table.

Condition of Built-in RUN/STOP Switch	Condition of General-Purpose Input Terminal Specified as RUN Terminal by Parameter	Status of PLC
RUN	OFF	RUN
	ON	RUN
STOP	OFF	STOP
	ON	RUN

Use either built-in RUN/STOP switch or the general input specified as RUN terminal. (When specifying the general-purpose terminal as the RUN terminal, always set the built-in RUN/STOP switch to STOP.)

2. When the remote running/stopping operation from the programming software is performed

For this operation, keep both the built-in RUN/STOP switch and the general-purpose input RUN terminal in the STOP position. If the stop command is given from the programming software after the PLC is started by either the built-in RUN/STOP switch or the general-purpose input RUN terminal, the PLC will be restored to the running status by giving the RUN command from the programming software. This can also be accomplished by setting the built-in RUN/STOP switch or the general-purpose input RUN terminal to STOP and then to RUN.

■ OPERATION AND TEST [POWER ON AND PLC RUNNING]

SELF-DIAGNOSTIC FUNCTION

When the PLC's power is turned on, its self-diagnostic function starts automatically. If there are no problems with the hardware, parameters or program, the PLC will start and the RUN command is given (RUN LED is lit). If any problems are found, the "ERR" LED flashes or lights.

TEST FUNCTIONS

Functions of the programming tool to turn on/off the PLC devices and change the current values/settings are effective or ineffective depending on the PLC status as shown below.

X: Effective O: Conditionally Effective - : Ineffective

Item	In Running Status	In Stopped Status
Forcible ON/OFF *1	Devices used in program	O *1
	Devices not in use	X
Change of current values of timers, counters, data registers, extension registers, extension file registers and file registers *4	Devices used in program	O *2, *3
	Devices not in use	X *3
Change of settings of timers and counters *5	When the program memory is the built-in EEPROM	X
	When the program memory is in the memory cassette and the PROTECT switch is on	-
	When the program memory is in the memory cassette and the PROTECT switch is off	X

1. Forcible ON/OFF

- ▶ The forcible ON/OFF function is effective on the input relays (X), output relays (Y), auxiliary relays (M), state (S), timers (T) and counters (C). On the display module, the function cannot be operated for the input relays (X).
- ▶ The forcible ON/OFF function can turn on or off the devices only for one scan. While the PLC is running, the function is substantially effective in clearing the current values of the timers (T), counters (C), data registers (D), index registers (Z and V) and extension registers (R) and in controlling the SET/RST circuit and self-retaining circuit. (The operation to forcibly turn on timers is effective only when the timers are driven by the program.)
- ▶ The results of forcible ON/OFF operation performed while the PLC in the stopped state or performed for devices not used in the program are retained. However, the results of the operation performed for the input relays (X) are not retained because the relays refresh input even while the PLC is in the stopped state. (They are updated according to the input terminal conditions.)

- Since the current values may be changed according to MOV instruction in the program and the operation results, the most recently obtained values are retained.
- Only display modules can change the current value by the extension file register test function.
- The current values of the file registers stored in the program memory cannot be monitored or tested on the display module.
- Change of timer and counter settings. The settings of the timers (T) and counters (C) can be changed only when the timers are driven by the program.

PROGRAM MODIFICATION FUNCTION

The sequence program can be transferred while the PLC is running or in the stopped state as shown below.

X: Effective - : Ineffective

Item		In Running Status	In Stopped Status
Batch Writing of File Registers (D) and Extension File Registers (ER)		-	X
Writing of Program to PLC	Partial Modification of Program	X	X
	Modification of whole Program (Batch Writing)	-	X
Writing of Parameters to PLC		-	X
Writing of Comments to PLC		-	X

1. Since the writing function is used during running, the programming tool must support the write during RUN function, such as GX Works2.

BUILT-IN VARIABLE ANALOG POTENTIOMETER FUNCTION

The main unit has two built-in variable analog potentiometers (shown in the figure below). The current value increases from 0 to 255 when a variable analog potentiometer is turned clockwise.

The current value of each variable analog potentiometer is stored in special data registers shown below.

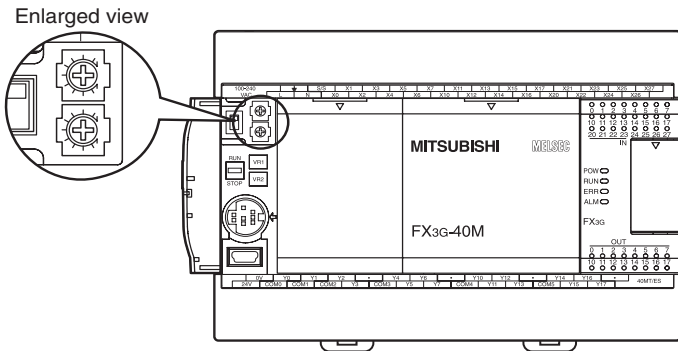

Volume	Data Register to Store Current Value
VR1 : variable analog potentiometer1	D8030 (Integer from 0 to 255)
VR2 : variable analog potentiometer2	D8031 (Integer from 0 to 255)

Use example 1 of variable analog potentiometer

The current value of VR1 is used as the set value of a timer.

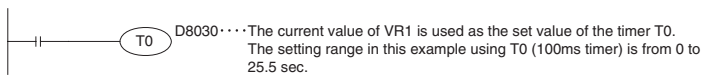

Use example 2 of variable analog potentiometer

The current value of VR2 multiplied by "10" is used as the set value of a timer.

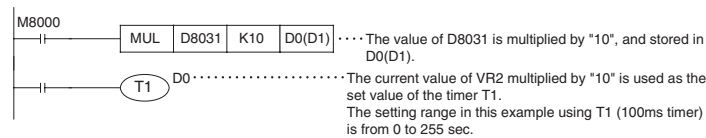

9. MAINTENANCE

This PLC does not incorporate consumable parts that are factors in the reduction of service life. However, the output relays (points of contact) and batteries (option) have a limited life expectancy.

PERIODIC INSPECTION - BATTERY LIFE, ETC.

1. Battery

Model FX3U-32BL battery: Standard life: 5 years (at ambient temperature of 25°C (77°F))

2. Other devices

When inspecting the battery, check the following points.

- ▶ Check that the temperature in the panel is not abnormally increased by other heat generating bodies or direct sunlight.
- ▶ Check that dust or conductive dust has not entered the panel.
- ▶ Check for loosening of wiring and other abnormalities.

3. Battery Replacement

When the battery voltage drops while the PLC power is on, the "ALM" LED on the panel is lit in red, and M8005 and M8006 (latch) are turned on. The memory can be retained for about one month after the lamps turn on. However, the operators may not immediately find the lamps to be on. Prepare a new battery promptly, and replace the battery with the new one.

MAINTENANCE – PRODUCT LIFE OF RELAY CONTACTS

The product life of relay contacts varies considerably depending on the load type used. Take care that loads generating reverse electromotive force or rush current may cause poor contact or deposition of contacts which may lead to considerable reduction of the contact product life.

Inductive load

Inductive loads generate large reverse electromotive force between contacts at shutdown, which may cause arcing. At a fixed current consumption, as the power factor (phase between current and voltage) gets smaller, the arc energy gets larger.

The standard life of contacts used for Inductive loads, such as contactors and solenoid valves, is 500,000 operations at 20VA. The following table shows the approximate life of a relay based on the results of an operation life test.

Load Capacity	Contact Life	
20VA	0.2A/100VAC	3,000,000 times
	0.1A/200VAC	
35VA	0.35A/100VAC	1,000,000 times
	0.17A/200VAC	
80VA	0.8A/100VAC	200,000 times
	0.4A/200VAC	

The product life of relay contacts becomes considerably shorter than the above conditions when the rush overcurrent is shut down.

Some types of inductive loads generate rush current 5 to 15 times the stationary current at activation. Make sure that the rush current does not exceed the current corresponding to the maximum specified resistance load.

Lamp load

Lamp loads generally generate rush current 10 to 15 times the stationary current. Make sure that the rush current does not exceed the current corresponding to the maximum specified resistance load.

CAPACITIVE LOAD

Capacitive loads can generate rush current 20 to 40 times the stationary current. Make sure that the rush current does not exceed the current corresponding to the maximum specified resistance load. Capacitive loads such as capacitors may be present in electronic circuit loads including inverters.

10. TROUBLESHOOTING

■ TROUBLESHOOTING WITH LEDES

When trouble occurs, check the LEDs on the PLC to identify the problem with the PLC.

State of LED	State of PLC	Remedies
On	Power of the specified voltage is being correctly supplied to the power supply terminal.	The power supply is normal.
Flashing	One of the following problems may have occurred. <ul style="list-style-type: none"> Power of the specified voltage and current is not being supplied to the power supply terminal. External wiring is incorrect. Internal error of PLC 	Check the supply voltage. <ul style="list-style-type: none"> After disconnecting the cables other than the power cable, re-apply power to the PLC, and check for changes in the state. If the problem persists, consult your local Mitsubishi Electric representative.
Off	One of the following problems may have occurred. <ul style="list-style-type: none"> The power supply is off. External wiring is incorrect. Power of the specified voltage is not being supplied to the power supply terminal. The power cable is broken. 	<ul style="list-style-type: none"> If the power is not off, check the power supply and the power supply route. If power is being supplied correctly, consult your local Mitsubishi Electric representative. After disconnecting the cables other than the power cable, re-apply power to the PLC, and check for changes in the state. If the problem persists, consult your local Mitsubishi Electric representative.

■ ALM LED [ON/OFF]

This LED is valid when the optional battery is installed and the battery mode is selected using a parameter.

State of LED	State of PLC	Remedies
On	The battery voltage is low.	Immediately replace the battery.
Off	The battery voltage is higher than the value set with D8006.	Normal

■ ERR LED [ON/FLASHING/OFF]

State of LED	State of PLC	Remedies
On	A watchdog timer error may have occurred, or the hardware of the PLC may be damaged.	<ol style="list-style-type: none"> Stop the PLC, and re-apply power. If ERR LED goes off, a watchdog timer error may have occurred. Take any of the following measures. <ul style="list-style-type: none"> Review the program. The maximum value (D8012) of the scan time should not exceed the setting (D8000) of the watchdog timer. Check that the input used for input interruption or pulse catch is not being abnormally turned on and off in one scan. Check that the frequency of the pulse (duty of 50%) input to the high-speed counter does not exceed the specified range. Add the WDT instructions. Add some WDT instructions to the program, and reset the watchdog timer several times in one scan. Change the setting of the watchdog timer. Change the watchdog timer setting (D8000) in the program so that the setting is larger than the maximum value of the scan time (D8012). Remove the PLC and supply power to it from another power supply on a desk. If the ERR LED goes off, noise may have affected the PLC. Take the following measures. <ul style="list-style-type: none"> Check the ground wiring, and reexamine the wiring route and installation location. Fit a noise filter onto the power supply line. If the ERR LED does not go off even after the measures stated in (1) and (2) are taken, consult your local Mitsubishi Electric representative.

State of LED	State of PLC	Remedies
Flashing	One of the following errors has occurred in the PLC. <ul style="list-style-type: none"> Parameter error Syntax error Ladder error 	Perform PLC diagnosis and program check with the programming tool.
Off	No errors that stop the PLC have occurred.	If the operations of the PLC are abnormal, perform PLC diagnosis and program check with the programming tool. An I/O error, Comms error or Runtime error may have occurred.

■ OUTPUT DOES NOT OPERATE

1. Output does not turn on

Stop the PLC, and forcibly turn the inoperable output on then off with a peripheral device or the display module to check its operation. Check for troubles with external wiring.

- When the output operates
The output may be turned off unintentionally in the program. Reexamine the program. (Duplicate coil or RST instructions)

- When the output does not operate
Check the configuration of the connected devices and the connection of the extension cables. If the configuration of the external wiring and connected devices and the connection of the extension cables are acceptable, the output circuit may be damaged. Consult your local Mitsubishi Electric representative.

2. Output does not turn off

Stop the PLC, and check that the output turns off. Check for trouble with external wiring.

- When the output turns off

The output may be turned on unintentionally in the program.
Check that there are no duplicate coils in the program.

- When the output does not turn off

The output circuit may be damaged.

Consult your local Mitsubishi Electric representative.

■ 24VDC INPUT DOES NOT OPERATE

1. Input does not turn on

Disconnect the external wiring and connect the S/S terminal and the 0V terminal or the 24V terminal. Short-circuit the 0V terminal or 24V terminal not connected to the S/S terminal and the input terminal, then check the input display LED or a peripheral device to confirm that the input turns on.

	Measures
When Input Turns On	Check that the input device does not have a built-in diode or parallel resistance. .
When Input Does Not Turn On	Measure the voltage between the 0V terminal or 24V terminal not connected to the S/S terminal and the input terminal with a tester to confirm that the voltage is 24VDC. • Check the configuration of the external wiring and connected devices and the connection of the extension cables.

2. Input does not turn off

Check for leakage current from input devices.

If the leakage current is larger than 1.5mA, it is necessary to connect a bleeder resistance.

MITSUBISHI ELECTRIC AUTOMATION, INC.

500 Corporate Woods Parkway, Vernon Hills, IL 60061
Ph 847.478.2100 • Fx 847.478.2253

us.MitsubishiElectric.com/fa/en/support

January, 2016 • ©2016, Mitsubishi Electric Automation, Inc. •
Specifications subject to change without notice. • All rights reserved

AZ-JY997D49401-A



Mitsubishi Electric Automation, Inc.