

SIEMENS

SIMATIC

ET 200S distributed I/O IM151-3 PN FO interface module (6ES7151-3BB22-0AB0)

Manual

Preface

Properties

1

Parameters

2

Functions

3

Alarm, error and system messages

4

Response times

5

Connection

6

Order numbers

A

Safety Guidelines

This manual contains notices you have to observe in order to ensure your personal safety, as well as to prevent damage to property. The notices referring to your personal safety are highlighted in the manual by a safety alert symbol, notices referring only to property damage have no safety alert symbol. These notices shown below are graded according to the degree of danger.

⚠ DANGER
indicates that death or severe personal injury will result if proper precautions are not taken.
⚠ WARNING
indicates that death or severe personal injury may result if proper precautions are not taken.
⚠ CAUTION
with a safety alert symbol, indicates that minor personal injury can result if proper precautions are not taken.
CAUTION
without a safety alert symbol, indicates that property damage can result if proper precautions are not taken.
NOTICE
indicates that an unintended result or situation can occur if the corresponding information is not taken into account.

If more than one degree of danger is present, the warning notice representing the highest degree of danger will be used. A notice warning of injury to persons with a safety alert symbol may also include a warning relating to property damage.

Qualified Personnel

The device/system may only be set up and used in conjunction with this documentation. Commissioning and operation of a device/system may only be performed by **qualified personnel**. Within the context of the safety notes in this documentation qualified persons are defined as persons who are authorized to commission, ground and label devices, systems and circuits in accordance with established safety practices and standards.

Prescribed Usage

Note the following:

⚠ WARNING
This device may only be used for the applications described in the catalog or the technical description and only in connection with devices or components from other manufacturers which have been approved or recommended by Siemens. Correct, reliable operation of the product requires proper transport, storage, positioning and assembly as well as careful operation and maintenance.

Trademarks

All names identified by ® are registered trademarks of the Siemens AG. The remaining trademarks in this publication may be trademarks whose use by third parties for their own purposes could violate the rights of the owner.

Disclaimer of Liability

We have reviewed the contents of this publication to ensure consistency with the hardware and software described. Since variance cannot be precluded entirely, we cannot guarantee full consistency. However, the information in this publication is reviewed regularly and any necessary corrections are included in subsequent editions.

Preface

Preface

Purpose of the manual

This manual supplements the *ET 200S Distributed I/O System* Operating Instructions. General functions for the ET 200S are described in the *ET 200S Distributed I/O System* Operating Instructions.

The information in this document along with the operating instructions enables you to commission the ET 200S.

Basic knowledge requirements

To understand these operating instructions you should have general knowledge of automation engineering.

Scope of the manual

This manual applies to this ET 200S module. It describes the components that are valid at the time of publication.

Recycling and disposal

Thanks to the fact that it is low in contaminants, this ET 200S module is recyclable. For environmentally compliant recycling and disposal of your electronic waste, please contact a company certified for the disposal of electronic waste.

Additional support

If you have any questions relating to the products described in these operating instructions, and do not find the answers in this document, please contact your local Siemens representative.

<http://www.siemens.com/automation/partner>

The portal to our technical documentation for the various SIMATIC products and systems is available at:

<http://www.siemens.com/automation/simatic/portal>

The online catalog and ordering system are available at:

<http://www.siemens.com/automation/mall>

Training center

We offer courses to help you get started with the ET 200S and the SIMATIC S7 automation system. Please contact your regional training center or the central training center in D - 90327, Nuremberg, Germany.

Phone: +49 (911) 895-3200.

<http://www.siemens.com/sitrain>

Technical Support

You can reach technical support for all A&D projects

- using the support request web form:
<http://www.siemens.com/automation/support-request>
- Phone: + 49 180 5050 222
- Fax: + 49 180 5050 223

For more information about our technical support, refer to our Web site at

<http://www.siemens.de/automation/service>

Service & Support on the Internet

In addition to our documentation services, you can also make use of our comprehensive online knowledge base on the Internet.

<http://www.siemens.com/automation/service&support>

There you will find:

- Our Newsletter, which constantly provides you with the latest information about your products.
- The right documentation for you using our Service & Support search engine.
- The bulletin board, a worldwide knowledge exchange for users and experts.
- Your local contact for Automation & Drives in our contact database.
- Information about on-site services, repairs, spare parts. Lots more can be found on our "Services" pages.

Table of contents

	Preface	3
1	Properties	7
1.1	Interface module IM151-3 PN FO (6ES7151-3BB22-0AB0)	7
1.2	SNMP	11
1.3	SIMATIC Micro Memory Card	12
1.4	Firmware update	14
2	Parameters	15
2.1	Parameters for the IM151-3 PN FO interface module	15
2.2	Parameter description	15
2.2.1	Bus length	15
2.2.2	Interference frequency suppression	15
2.2.3	Reference junction slot	16
2.2.4	Reference junction input	16
3	Functions	17
3.1	Identification data for PROFINET IO	17
3.2	Configuring port 1 and port 2	19
4	Alarm, error and system messages	21
4.1	Diagnostics using LED display	21
4.2	Diagnostic messages of the electronic modules	24
4.3	Substitute value behavior	25
4.4	Diagnostics with STEP 7	25
4.4.1	Diagnostics readout	25
4.4.2	Channel diagnostics	26
4.4.3	Incorrect module configurations of ET 200S on the PROFINET IO	29
4.4.4	Interruption of the ET 200S backplane bus	29
4.4.5	Failure of the load voltage from the power module	31
4.4.6	STOP of the IO controller and recovery of the IO device	31
4.5	Maintenance interrupts	32
4.6	Evaluating the interrupts of the ET 200S	33

5	Response times	35
5.1	Response times of PROFINET IO	35
5.2	Response time for digital input modules	36
5.3	Response time for digital output modules.....	36
5.4	Response time for analog input modules.....	37
5.5	Reaction times of analog output modules.....	38
5.6	Response times for a 4 IQ-SENSE electronic module	39
5.7	Response times for technology modules	39
6	Connection	41
6.1	Connecting interface module IM151-3 PN FO with PROFINET IO interface (optical).....	41
6.2	Connecting the voltage supply	43
A	Order numbers	45
	Index	47

Properties

1.1 Interface module IM151-3 PN FO (6ES7151-3BB22-0AB0)

Properties

The IM151-3 PN FO interface module has the following properties:

- It interconnects ET 200S with PROFINET IO via fiber-optic cable.
- It prepares the data for the electronic modules and motor starters that are fitted.
- It supplies the backplane bus.
- Integrated interfaces for plastic fiber-optic cable (POF)
- Integrated switch with 2 ports
- Transfer and backup of the device name on SIMATIC Micro Memory Card
- Firmware update
 - Via SIMATIC Micro Memory Card
 - Via PROFINET IO
- The reference potential M of the rated supply voltage of the IM151-3 PN FO to the mounting rail (protective conductor) is connected by means of an RC combination. This permits an ungrounded configuration.
- Supported Ethernet services: ping, arp, Net diagnostics (SNMP)/MIB-2
- Interrupts
 - Diagnostic interrupts
 - Process interrupts
 - Insert/remove module interrupts
 - Maintenance interrupts
- Port diagnostics
- Port disabling
- Records for IO modules
- Identification data
- The maximum address space is 256 bytes I/O data.
- A maximum of 63 modules can be operated with the IM151-3 PN FO.
- Maximum distance between two PROFINET FO interfaces when using plastic fiber-optic cables (POF): 50 m.
- The maximum bus length at the backplane bus is 2 m.
- Summary of modules within one byte (packing)
- Use of fail-safe modules (PROFIsafe V2 or higher)
- IRTflex (RT Class 2)

Isochronous Realtime Ethernet IRTflex (RT Class 2)

IRTflex (RT Class 2) denotes a highly stable form of isochronous communication over PROFINET IO.

This procedure is characterized by particularly simple engineering and high flexibility for network expansions.

In the case of PROFINET IO with IRTflex, a sync master generates a signal with which the sync slaves synchronize themselves. The sync master and sync slaves belong to a sync domain that is configured using STEP 7.

For additional information, refer to the STEP 7 Online Help.

Compatibility with the predecessor module

Interface module IM151-3 PN FO (6ES7151-3BB22-0AB0) is compatible with interface module IM151-3 PN FO (6ES7151-3BB21-0AB0).

The new interface module directly replaces the predecessor module in an existing system without the need for reconfiguration.

Firmware updates on the predecessor module are not supported.

Operational constraints

The following modules cannot be used with the IM151-3 PN FO:

Module	Up to order number	Up to product version
2AO U; HIGH FEATURE	6ES7135-4LB01-0AB0	3
2AO I; HIGH FEATURE	6ES7135-4MB01-0AB0	3
1SI 3964(R)/ASCII	6ES7138-4DF00-0AB0	4
1SI Modbus/USS	6ES7138-4DF01-0AB0	4
2PULSE	6ES7138-4DD00-0AB0	6
1Count 24V/100kHz	6ES7138-4DA03-0AB0	-
Motor starter <ul style="list-style-type: none">• Direct starter• Reversing starter		3RK1301-xxxxx-1AA1 3RK1301-xxxxx-1AA1

Pin assignment

The following table shows the pin assignment of the IM151-3 PN FO interface module for the 24 V DC voltage supply and of the SC RJ interfaces for PROFINET IO:

Table 1-1 Pin assignment of the IM151-3 PN FO interface module

View	Signal name	Description
	①	Receiver/receive data
	②	Sender/transmit data
	1L+	24 V DC
	1L+	24 V DC
	M	Ground
	M	Ground

Block diagram

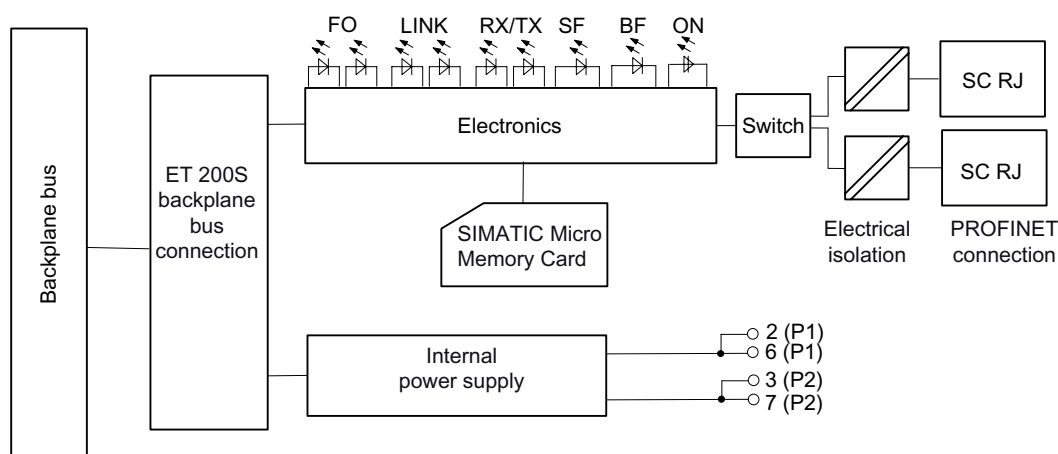

Figure 1-1 Block diagram for the IM151-3 PN FO interface module

Technical data IM151-3 PN FO (6ES7151-3BB22-0AB0)

Dimensions and weight	
Dimension B (mm)	60
Weight	Approx. 150 g
Module-specific specifications	
Data transmission rate	<ul style="list-style-type: none"> • 100 Mbps for Ethernet services • 100 Mbps full duplex for PROFINET IO
Transmission procedure	100BASE-FX
Autonegotiation	Yes; half duplex, full duplex
Autocrossing	No
Bus protocol	PROFINET UDP/IP
Supported Ethernet services	<ul style="list-style-type: none"> • ping • arp • Net diagnostics (SNMP)/MIB-2
PROFINET interface	2x SC RJ
Manufacturer ID (VendorID)	002A _H
Device ID (DeviceID)	0301 _H
Voltages, currents, potentials	
Rated supply voltage of the electronic components (1L+)	24 V DC
<ul style="list-style-type: none"> • Incorrect polarity protection 	Yes
<ul style="list-style-type: none"> • Power failure bypass 	Min. 20 ms
Galvanic isolation	
<ul style="list-style-type: none"> • Between the backplane bus and electronic components 	No
<ul style="list-style-type: none"> • Between Ethernet and electronic components 	Yes
<ul style="list-style-type: none"> • Between the supply voltage and electronic components 	No
Permitted potential difference (to the rail)	75 V DC/60 V AC
Insulation test voltage	500 V DC
Current consumption from rated supply voltage (1L+)	Approx. 200 mA
Power dissipation of the module	Approx. 3 W
Status, interrupts, diagnostics	
Interrupts	Yes
Diagnostic function	Yes
<ul style="list-style-type: none"> • Batch error 	Red LED "SF"
<ul style="list-style-type: none"> • Bus monitoring PROFINET IO 	Red "BF" LED
<ul style="list-style-type: none"> • Monitoring of the supply voltage of the electronics 	Green "ON" LED
<ul style="list-style-type: none"> • Diagnostics 	One yellow LED "FO" per port
<ul style="list-style-type: none"> • Existing connection to network 	One green LED "LINK" per port
<ul style="list-style-type: none"> • Transmitting/receiving data on the network 	One yellow LED "RX/TX" per port

1.2 SNMP

The interface module supports the Ethernet service SNMP. MIB-2 (RFC1213) is supported. R/W objects can be changed using SNMP tools and are stored in the module.

Following replacement with a brand new module, the R/W objects of the interface module are set to the factory settings.

Reset to default settings

NOTICE
When factory settings are restored, the stations in a line can fail.

"Reset to default settings" is only possible if the IO device is not exchanging data with a controller.

Remanent stored SNMP parameters are reset to default settings (*STEP 7*V5.3 SP 3 and higher) in HW Config dialog "Target system > Ethernet > Edit Ethernet nodes" "Reset" button under "Reset to default settings".

The following data is **not** deleted when resetting:

- The device name is saved to the SIMATIC Micro Memory Card.
- The MAC address
- I&M data

Note

Deleting the device name

To prevent a new module with a "strange" device name from starting, delete the device name from the SIMATIC Micro Memory Card.

Open the properties dialog box of the interface module in HW Config. Confirm the properties dialog box without entering a device name in the "Assign device name" field.

1.3 SIMATIC Micro Memory Card

SIMATIC Micro Memory Card (MMC) as memory medium

A SIMATIC Micro Memory Card is used as a memory medium for the IM151-3 PN FO.

A 64 k MMC is sufficient for saving the device name.

An MMC of 2 MB or higher is required for a firmware update.

Principle

Position of the module slot for the SIMATIC Micro Memory Card

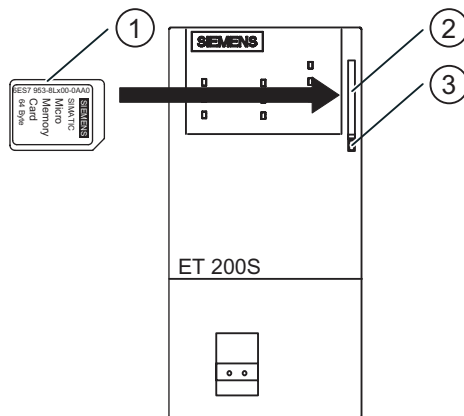

- ① SIMATIC Micro Memory Card
- ② Module slot
- ③ Ejector

Insertion of the SIMATIC Micro Memory Card

Note

You can save **either** process-related data (device names) **or** firmware update data on **one** MMC.

Service life of a SIMATIC Micro Memory Card

The service life of a SIMATIC Micro Memory Card essentially depends on the following factors:

- Number of deletion or programming operations
- External factors, such as ambient temperature

At an ambient temperature of up to 60°C, a SIMATIC Micro Memory Card has a service life of 10 years, with a maximum of 100,000 write/delete operations.

NOTICE

Possible data loss

If the maximum number of write/delete operations is exceeded, data loss is possible.

Available SIMATIC Micro Memory Cards

Table 1-2 Available SIMATIC Micro Memory Cards

Description	As of order number	Memory size
SIMATIC Micro Memory Card 64k	6ES7953-8LF11-0AA0	64 KB
SIMATIC Micro Memory Card 128k	6ES7953-8LG11-0AA0	128 KB
SIMATIC Micro Memory Card 512k	6ES7953-8LJ11-0AA0	512 KB
SIMATIC Micro Memory Card 2M	6ES7953-8LL11-0AA0	2 MB
SIMATIC Micro Memory Card 4M	6ES7953-8LM11-0AA0	4 MB
SIMATIC Micro Memory Card 8M	6ES7953-8LP11-0AA0	8 MB

Inserting/replacing the card

Note

In order to ensure that it will function correctly, the SIMATIC Micro Memory Card must only be inserted or removed with the power turned off.

The beveled corner of the SIMATIC Micro Memory Card prevents it from being inserted the wrong way round (reverse polarity protection).

The module slot for the SIMATIC Micro Memory Card is located behind the front door on the interface module. The front door has a protruding edge for opening.

To eject the card, push in the ejector with a suitable object (such as a small screwdriver or ball-point pen).

1.4 Firmware update

Firmware update

The firmware of an IM151-3 PN FO can be updated:

- Using a SIMATIC Micro Memory Card with at least 2 MB of memory.

You can find additional information on the Internet at:

<http://support.automation.siemens.com/WW/view/en/19241998/133100>

- Via PROFINET IO, e.g., using HW Config or in the SIMATIC Manager via "Target system > Display accessible nodes".

For additional information, refer to the *STEP 7* Online Help.

Requirements

In order to update the firmware of an IM151-3 PN FO you require:

- *STEP 7*, V5.3 SP 2 or higher
- A SIMATIC Micro Memory Card
- A PC or programming device with a facility for writing to a SIMATIC Micro Memory Card

NOTICE

When the firmware is updated, the stations in a line can fail.

Parameters

2.1 Parameters for the IM151-3 PN FO interface module

Table 2-1 Parameters for the IM151-3 PN FO interface module

IM151-3	Value range	Default setting	Applicability
Bus length	≤ 1 m/> 1 m	≤ 1 m	ET 200S
Interference frequency suppression	50 Hz/60 Hz	50 Hz	ET 200S
Reference junction slot	None/2 to 63	None	ET 200S
Reference junction input	RTD on channel 0/ RTD on channel 1	0	ET 200S

2.2 Parameter description

2.2.1 Bus length

≤ 1 m: The default setting for the maximum bus length is 1 m.

> 1 m: The bus length of the ET 200S is > 1 m and can be up to 2 m. However, this setting will increase the response time of the ET 200S.

2.2.2 Interference frequency suppression

The frequency of your AC power system can interfere with the measured value especially when measuring in low voltage ranges and using thermocouple elements. Enter the line frequency for your system here (50 Hz or 60 Hz).

The interference frequency suppression parameter applies to all analog electronic modules. This parameter is also used to specify the integration and conversion time of the various modules. See the technical data for the analog electronic modules.

2.2.3 Reference junction slot

This parameter can be used to assign a slot (none, 2 to 12/2 to 63) with a channel location for measuring the reference temperature (calculation of the compensation value).

Reference

Refer to the *manuals* for the *analog electronic modules* for information on connecting thermocouples.

2.2.4 Reference junction input

This parameter can be used to set the channel (0/1) for measuring the reference temperature (calculation of the compensation value) for the assigned slot.

Reference

Refer to the *manuals* for the *analog electronic modules* for information on connecting thermocouples.

Functions

3.1 Identification data for PROFINET IO

Definition

Identification data are data that are stored in a module for assisting the user in:

- checking the system configuration
- locating modified system hardware
- troubleshooting a system

Identification data enable modules to be uniquely identified online.

In *STEP 7*, the identification data are displayed in the "Module Information - IM 151" and "Properties ..." tabs (see *STEP 7* Online Help).

Reading of identification data

You can directly access specific identification data by selecting **Read data record**. Obtain the corresponding part of the identification data under the associated data record index.

The data records are structured as follows:

Table 3-1 Basic structure of data records with identification data for PROFINET IO

Contents	Length (bytes)	Coding (hex)
Header information		
BlockType	2	I&M0: 0020 I&M1: 0021 I&M2: 0022 I&M3: 0023
BlockLength	2	I&M0: 0038 I&M1: 0038 I&M2: 0012 I&M3: 0038
BlockVersionHigh	1	01
BlockVersionLow	1	00
Identification data		
Identification data (see table below)	I&M0/Index AFF0 hex: 54 I&M1/Index AFF1 hex: 54 I&M2/Index AFF2 hex: 16 I&M3/Index AFF3 hex: 54	

The data structures in the data records correspond to the PROFINET IO definitions.

Functions

3.1 Identification data for PROFINET IO

Table 3-2 Identification data for PROFINET IO

Identification data	Access	Default setting	Description
Identification data 0: (data record index AFF0 hex)			
VendorIDHigh	read (1 bytes)	00 hex	The name of the manufacturer is stored here. (42 dec = SIEMENS AG)
VendorIDLow	read (1 bytes)	2A hex	
Order_ID	read (20 bytes)		Order number of the module
IM_SERIAL_NUMBER	read (16 bytes)	-	Serial number (device specific)
IM_HARDWARE_REVISION	read (2 bytes)	1	Corresponding hardware version
IM_SOFTWARE_REVISION	read	Firmware version	Indicates the firmware version of the module.
• SWRevisionPrefix	(1 byte)	V, R, P, U, T	
• IM_SWRevision_Functional_Enhancement	(1 byte)	00 - FF hex	
• IM_SWRevision_Bug_Fix	(1 byte)	00 - FF hex	
• IM_SWRevision_Internal_Change	(1 byte)	00 - FF hex	
IM_REVISION_COUNTER	read (2 bytes)	-	Provides information on parameter modifications on the module.
IM_PROFILE_ID	read (2 bytes)	0000	Generic device
IM_PROFILE_SPECIFIC_TYPE	read (2 bytes)	0005 hex	on interface modules
IM_VERSION	read	0101 hex	Provides information on the identification data version (0101 hex = version 1.1)
• IM_Version_Major	(1 byte)		
• IM_Version_Minor	(1 byte)		
IM_SUPPORTED	read (2 bytes)	000E hex	Provides information on existing identification data (I&M1 to I&M3)
Maintenance data 1: (data record index AFF1 hex)			
IM_TAG_FUNCTION	Read/write (32 bytes)	-	Define a unique identifier for the module in this record.
IM_TAG_LOCATION	Read/write (22 bytes)	-	Define the installation location of the module.
Maintenance data 2: (data record index AFF2 hex)			
IM_DATE	Read/write (16 bytes)	YYYY-MM-DD HH:MM	Enter the installation date of the module here.
Maintenance data 3: (data record index AFF3 hex)			
IM_DESCRIPTOR	Read/write (54 bytes)	-	Define a comment describing the module in this record.

3.2 Configuring port 1 and port 2

Introduction

The IM151-3 PN FO interface module can diagnose 2 ports: X1 P1 and X1 P2.

Requirement

- The ports must be configured in HW Config.
- The port diagnostics must be enabled.

Configuring the ports in HW Config

Configure both ports in HW Config in the "Properties of the IM151-3 PN port..." dialog box:

- Addresses tab: Diagnostic address of the respective port.
- Topology tab:
You can specify a port interconnection and the fiber-optic cable.
- Options tab:
To enable the port diagnostics, select the following for "Connection" under "Transmission Medium/Duplex": "Automatic Settings (monitor)".

Reference

See *STEP 7* Online Help.

See also

Maintenance interrupts (Page 32)

Alarm, error and system messages

4.1 Diagnostics using LED display

LED display

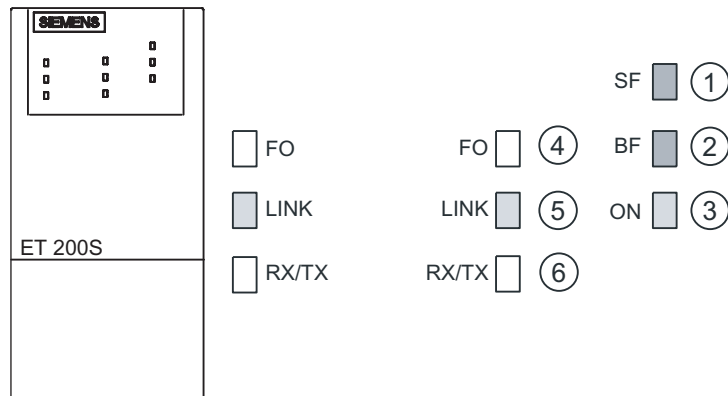

- ① Batch error (red)
- ② Bus fault (red)
- ③ Supply voltage (green)
- ④ Status of the FO path (yellow), per port
- ⑤ Connection to a switch or IO controller (green), per port
- ⑥ Data exchange (yellow), per port

Status and error displays

Table 4-1 Status and error displays of the IM151-3 PN FO

LEDs			Meaning	Remedy
SF	BF	ON		
Off	Off	Off	There is no voltage at the interface module, or the interface module has a hardware defect.	<ul style="list-style-type: none"> Switch on the 24 V DC supply voltage at the interface module.
*	*	On	There is voltage at the interface module.	–
*	Flashing 0.5 Hz	On	<p>Faulty or no connect message frame - no data transfer between the IO controller and the interface module (IO device), although the device is physically connected to the switch.</p> <p>Causes:</p> <ul style="list-style-type: none"> Incorrect device name Configuration error Parameter assignment error There is an error in an I/O module, or the bus cable to the controller is missing. 	<ul style="list-style-type: none"> Check the interface module. Check the configuration and parameter assignment. Check the device name. Assign a valid device name to the interface module. Check the IO controller
*	On	On	The IO device is not connected to a switch.	<ul style="list-style-type: none"> Establish a connection to the IO controller (via a switch). Assign a valid device name to the interface module. Check the bus configuration. Check that the bus connector is correctly inserted. Check whether the bus cable to the I/O controller is interrupted.
*	On	On	<ul style="list-style-type: none"> The prefabrication of the FO cable is bad. The fiber-optic cable attenuate too much. 	<ul style="list-style-type: none"> Check the firm fit of the FO connector. Check the cable prefabrication. Replace the fiber-optic cable.
On	*	On	<p>The configured structure of the ET 200S does not coincide with the actual structure of the ET 200S.</p> <ul style="list-style-type: none"> There is an error in an I/O module, or the interface module is defective. Incoming diagnostics 	<ul style="list-style-type: none"> Check the structure of the ET 200S for missing or defective modules or whether an unconfigured module is inserted. Check the configuration (using <i>STEP 7</i>, for example), and correct the parameter assignment error. Replace the interface module, or contact your Siemens representative.

LEDs			Meaning	Remedy
SF	BF	ON		
On	Off	On	<ul style="list-style-type: none"> No S7 program on the SIMATIC Micro Memory Card No SIMATIC Micro Memory Card is inserted. The SIMATIC Micro Memory Card is out of memory, or can not provide sufficient memory for the device name. No suitable SIMATIC Micro Memory Card is inserted (i.e., no SIMATIC Micro Memory Card from Siemens). <p>In this state, the IO device cannot be accessed.</p>	<ul style="list-style-type: none"> Format the SIMATIC Micro Memory Card. Before switching on the supply voltage, insert an empty SIMATIC Micro Memory Card in the IM151-3 PN FO.
On	On	On	A brand new SIMATIC Micro Memory Card is being formatted.	<ul style="list-style-type: none"> Wait until the formatting sequence is complete. This may take several minutes. The formatting sequence is completed when the SF LED goes out.
Off	Off	On	Data exchange is taking place between the IO controller and the ET 200S. The target configuration and actual configuration of the ET 200S match.	–
On	On	Off	FW update busy	
Off	Flashing 0.5 Hz	Off	FW update successfully completed	
On	Flashing 0.5 Hz	Off	External error during FW update (incorrect FW, for example)	<ul style="list-style-type: none"> Use the correct FW for the update.
On	Flashing 2 Hz	Off	Internal error during FW update (possible read/write error)	<ul style="list-style-type: none"> Repeat the FW update.
*) not relevant				

4.2 Diagnostic messages of the electronic modules

LEDs			Meaning	Remedy
FO	LINK	RX/TX		
*	Off	Off	No connection to switch/I/O controller.	<ul style="list-style-type: none"> • Check the fiber-optic cable.
*	On	*	Connection to switch/I/O controller.	–
*	On	On	Transmission/reception is in progress.	–
On	*	*	Maintenance demanded/maintenance required: Attenuation through the fiber-optic cable is too high making operation no longer possible.	Check the affected data transmission link for the following causes: <ul style="list-style-type: none"> • Damage to the fiber-optic cable • Correct installation of the PROFINET connector/PROFINET connection • Adherence to the max. length of 50 m for POF cables • Check the firm fit of the FO connector.
*) not relevant				

4.2 Diagnostic messages of the electronic modules

Actions after a diagnosis message

Each diagnostic message triggers the following actions:

- The SF LED of the interface module lights up.
- Several simultaneous diagnostic messages are possible.
- Diagnostics data are reported as diagnosis interrupts and can be read from data records.
- Following a diagnostic message, they are saved to the diagnostics buffer of the I/O controller.
- OB 82 is called. If OB 82 is not available, the I/O controller goes into STOP.
- Acknowledgment of the diagnostic interrupt (thereafter a new interrupt is possible).

Causes of faults and corrective measures

The causes of faults and corrective measures for the diagnosis messages are described in this manual in the chapter entitled "Channel diagnostics" under "Interrupt, cause and system messages to the PROFIBUS DP."

See also

Channel diagnostics (Page 26)

4.3 Substitute value behavior

Substitute value behavior

In all PROFINET IO interface modules, substitute value behavior is slot-selective.

Each output behaves according to its parameterized substitute value behavior, e.g., "At zero current/voltage" or "Output substitute value". Substitute value behavior is triggered when the user data accompanying each instance is set to "Bad".

4.4 Diagnostics with STEP 7

4.4.1 Diagnostics readout

Options for reading out the diagnostics

Table 4-2 Reading out the diagnostics with STEP 7

Automation system with IO controller	Block or tab in <i>STEP 7</i>	Application	Reference
SIMATIC S7	Open in HW Config with the menu command "Station > Online"	Device diagnostics in form of plain text on STEP 7 interface (in the Quick View, Diagnostics View, or Module Status windows)	"Diagnosing hardware" in <i>STEP 7 online help</i>
	SFB 52 "RDREC"	Read data sets from the I/O device	SFB see <i>STEP 7 online help</i> (system functions/-function blocks)
	SFB 54 "RALRM"	Receiving interrupts from the IO device	SFB see <i>STEP 7 online help</i> (system functions/-function blocks)

4.4.2 Channel diagnostics

Definition

Channel diagnostics provide information about channel errors in the modules.

Channel errors are mapped as channel diagnoses in I/O diagnostics data records.

You can read all diagnostics data of a submodule slot, or of a slot, or of a device slot assigned to the I/O controller, or of an IO device. The distinction is made based on the data record number:

800A _H	Channel diagnostics for a submodule slot
800B _H	Vendor-specific channel diagnostics for a submodule slot (incoming)
800C _H	Vendor-specific channel diagnostics for a submodule slot (incoming and outgoing)
C00B _H	Vendor-specific channel diagnostics for a slot (incoming)
C00C _H	Vendor-specific channel diagnostics for a slot (incoming and outgoing)
E002 _H	Deviation of the set configuration from the actual configuration of an IO device assigned to an IO controller
E00A _H	Channel diagnostics for the channels assigned to an IO controller in an IO device
E00B _H	Vendor-specific channel diagnostics for the channels assigned to an IO controller in an IO device (incoming)
E00C _H	Vendor-specific channel diagnostics for the channels assigned to an IO controller in an IO device (incoming and outgoing)
F00A _H	Channel diagnostics for an IO device
F00B _H	Vendor-specific channel diagnostics for an IO device (incoming)
F00C _H	Vendor-specific channel diagnostics for an IO device (incoming and outgoing)

The data record is read with the SFB 52 RDREC (read data record).

Structure of diagnostic data records

You will find the diagnostic data records structure and programming examples in the *From PROFIBUS DP to PROFINET IO Programming Manual*.

Data records supported by ET 200S are based on PROFINET IO - Application Layer Service Definition V2.0.

You can download the standard at www.profibus.com at no cost.

Channel diagnostics

The channel diagnostics for the ET 200S with the IM151-3 are structured as follows:

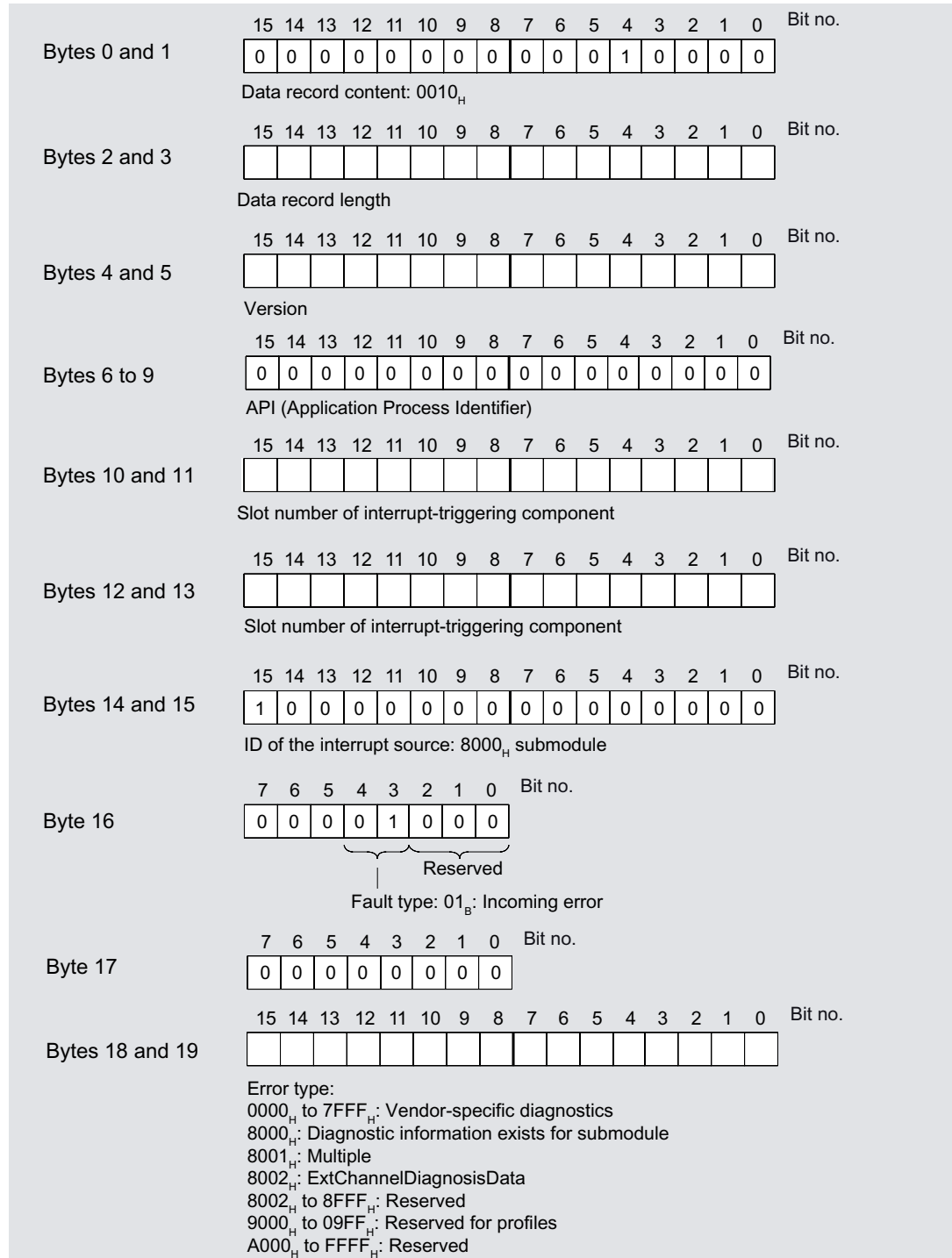

Figure 4-1 Structure of the channel diagnostics for ET 200S with IM151-3 (Part 1)

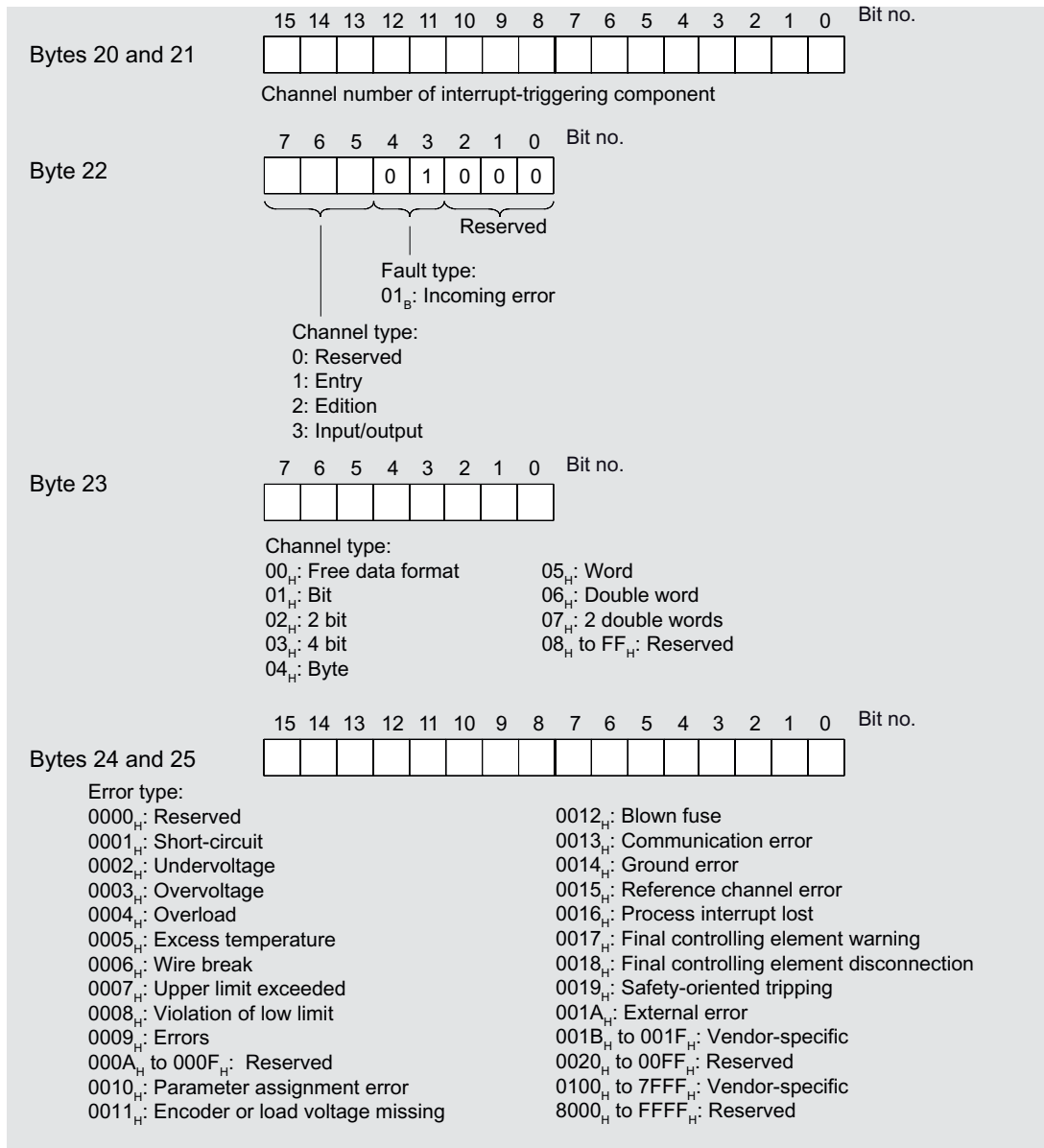

Figure 4-2 Structure of the channel diagnostics for ET 200S with IM151-3 (Part 2)

Bytes 20 to 25 are allocated to each additional error reported in this diagnostic message.

Error types of the other modules

The error types for the power modules, digital electronic modules, analog electronic modules, and technology modules can be found in the relevant manual.

4.4.3 Incorrect module configurations of ET 200S on the PROFINET IO

Incorrect module configuration

The following incorrect ET 200S module configuration lead to the failure of the ET 200S IO device or prevent data exchange.

- Starting with 2 missing modules
- Terminating module missing
- Number of modules exceeds maximum configuration
- Backplane bus fault (for example, defective terminal module)

Note

The I/O device will not start up if **one** module is missing (gap) and the ET 200S is switched on.

4.4.4 Interruption of the ET 200S backplane bus

Separate diagnostics of bus interruption

If the ET 200S does not start up, this may have the following causes:

- One or several missing modules
- Terminating module missing
- Number of modules exceeds maximum configuration
- Backplane bus fault (for example, defective terminal module)

If the data exchange is interrupted, it may have the following causes:

- At least two modules (compared to a missing module, this is no longer a gap, but rather a loose backplane bus)
- Terminating module missing
- Backplane bus fault (for example, defective terminal module)

ET 200S backplane bus interruptions do not trigger an interrupt.

You can read this information with STEP 7 in the SIMATIC Manager via "Accessible nodes" in the "Module status" window. To this end, the PD must be available in the PROFINET sub-net. The information is displayed in text format.

Grouping of diagnostics for bus interruption

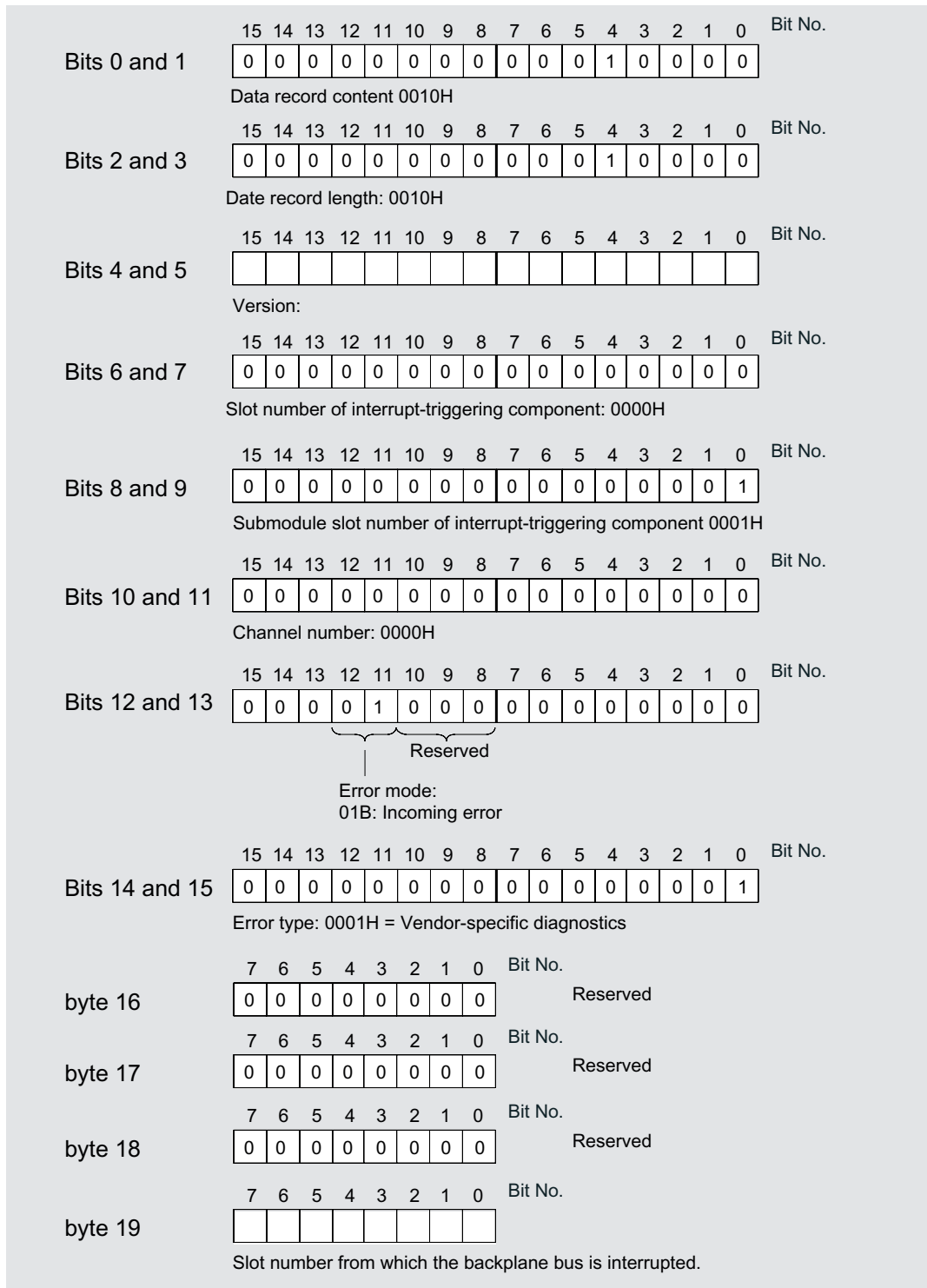

Figure 4-3 Structure of diagnostics of the bus interrupt for ET 200S with IM151-3 on the PROFINET IO

4.4.5 Failure of the load voltage from the power module

Load voltage failure

Should the load voltage of the power module fail, the electronic modules will behave as follows:

- If an electronic module is removed during a load voltage failure, a remove-module interrupt is triggered.
- If an electronic module is inserted during a load voltage failure, an insert-module interrupt is triggered.

Note

Electronic modules that are re-parameterized during operation must be parameterized yet again once the load voltage has been restored to the power module.

4.4.6 STOP of the IO controller and recovery of the IO device

Diagnostics events triggered by a STOP of the IO controller

Diagnostics frames received from the IO device while the IO controller is in STOP will not initiate a call of any corresponding OBs after when the IO controller goes into RUN. To obtain an overview of the device state, call OB 100.

Diagnostics after recovery of the IO device

After the recovery of an IO device, call SFB 52 to read data record E00CH. This record contains all diagnostics data of the IO device slots IO assigned to an IO controller.

4.5 Maintenance interrupts

Introduction

The PROFINET interfaces of the IM151-3 PN FO support the diagnostic and maintenance concept in PROFINET in accordance with IEC 61158-6-10. The goal is early detection and correction of potential errors.

Maintenance interrupts

On the IM151-3 PN FO, maintenance interrupts signal to the user when a fiber-optic cable must be checked or replaced. This depends on the increase in the attenuation value on the PROFINET interface.

The IM151-3 PN FO signals a maintenance interrupt to the higher-level diagnostics unit when the following events occur:

Maintenance interrupts	Event	Message/Meaning	LEDs
Level 1: Maintenance required	Loss of synchronization	<ul style="list-style-type: none"> No synchronization message frame received After parameter assignment or during operation, the sync master did not receive a synchronization message frame within the timeout period. Jitter lies outside the limits <ul style="list-style-type: none"> The maximum permissible jitter has been exceeded during synchronization. A sync slave has been synchronized by the sync master again. 	-
	Fiber-optic error	<ul style="list-style-type: none"> With a system reserve of 2 dB or more: ¹ (limit for POF cable): The affected transmission link must be checked. There is sufficient time to replace the fiber-optic cable before total failure. 	FO-LED illuminates
	Network error	<ul style="list-style-type: none"> Message frames rejected ² The integrated switch has rejected 3 message frames due to network overload. 	-
Level 2: Maintenance demanded	Fiber-optic error	<ul style="list-style-type: none"> With a system reserve of 0 dB or more: ¹ The affected fiber-optic cable must be immediately replaced to prevent total failure of the PROFINET devices. 	FO-LED illuminates
	Network error	<ul style="list-style-type: none"> Message frames rejected ² The integrated switch has rejected 10 message frames due to network overload. 	-
¹ Limit for POF cable. ² These diagnostic messages are automatically deleted after 1 second.			

System alarms in *STEP 7*

The maintenance information is generated in *STEP 7* with the following system alarms:

- Maintenance required, identified by a yellow wrench per port.
- Maintenance demanded, identified by an orange wrench per port.

See also

Configuring port 1 and port 2 (Page 19)

4.6 Evaluating the interrupts of the ET 200S

Introduction

The I/O device generates interrupts as a reaction to specific error events. Interrupts are evaluated based on the I/O controller used.

Evaluating interrupts with IO controller

The ET 200S supports the following interrupts

- Diagnostic interrupts
- Process interrupts
- Insert/remove module interrupts
- Maintenance interrupts

An interrupt automatically initiates execution of the interrupt OBs in the CPU of the IO controller (see the *Programming Manual System Software for S7-300/S7-400*, under "Program design").

Information on the cause and class of the error is already available based on the OB number and start information.

You can obtain detailed information on the error event in the error OB with SFB 54 RALRM (read supplementary interrupt information).

Triggering of a diagnostic interrupt

When an incoming or outgoing event (e.g., wire break) is registered the module triggers a diagnostic interrupt: if "Enable: Diagnostic interrupt" is set.

The CPU interrupts processing of the user program and processes the OB 82 diagnostic block instead. The event that triggered the interrupt is entered in the OB 82 start information.

Triggering a process interrupt

When the CPU receives a process interrupt it interrupts the user program and processes the OB 40 process interrupt. The event that triggered the interrupt is entered in the OB 40 start information.

Triggering of an insert/remove-module interrupt

The CPU interrupts processing of the user program and processes the OB 83 diagnostic block instead. The event that triggered the interrupt is entered in the OB 83 start information.

Diagnosis "Process interrupt lost"

The "Process interrupt lost" diagnosis is not currently available for the following modules:

- 2DI DC24V HF (6ES7131-4BB01-0AB0),
- 4DI DC24V HF (6ES7131-4BD01-0AB0) and
- 4DI UC24..48V HF (6ES7131-4CD00-0AB0)

Note

Process interrupts should not be used for technological purposes (e.g., cyclical generation of process interrupts).

Depending on the number of I/O modules and the communication load, process interrupts may be lost if more than approx. 50 are generated per second.

Response times

5.1 Response times of PROFINET IO

Calculation of the response time for IM151-3 PN

The following equation enables you to make an approximate calculation of the ET 200S response time:

Response time [μ s]: 390

+ Maximum out (380 + 9m + 11do) or (24m + 40ai + 80t)

+ Maximum out (120 + 9m) or (24 + 9do + 40ao + 80t)

- m Total number of all modules (power modules, digital electronic modules, analog electronic modules, 4 IQ-SENSE electronic modules, technological modules and motor starters)
- do Sum total of all digital output modules
- ao Sum total of all analog output modules
- ai Sum total of all analog input modules and 1SSI fast electronic modules
- t Number of all technology modules (except 1SSI fast)

Note

The formula specified applies to cyclic data transfer. The following requirements must be fulfilled:

- No diagnostics are reported.
 - No modules are removed and inserted.
 - PROFINET sending cycle 1 ms
-

5.2 Response time for digital input modules

Input delay

The reaction times of the digital input modules depend on the input delay.

Reference

Information on the input delays can be found in the technical data of the *manual* for the relevant digital electronic module.

5.3 Response time for digital output modules

Output delay

The response times correspond to the output delay.

Reference

Information on the output delays can be found in the technical data of the *manual* for the relevant digital electronic module.

5.4 Response time for analog input modules

Conversion time

The conversion time comprises the basic conversion time and the processing time for wire break check diagnostics.

In integrative conversion processes, the integration time is included directly in the conversion time.

Cycle time

The analog/digital conversion and the transfer of the digitized measured values to memory or to the backplane bus take place sequentially. In other words, the analog input channels are converted one after the other. The cycle time, that is, the time until an analog output value is converted again, is the sum of the conversion times of all the activated analog output channels of the analog input modules. You should deactivate unused analog input channels during parameter assignment in order to reduce the cycle time. The conversion and integration time for a deactivated channel is 0.

The following figure gives you an overview of what the cycle time for an n-channel analog input module comprises.

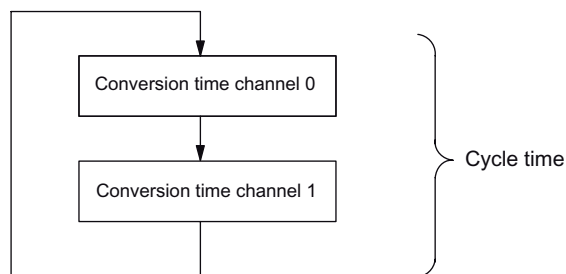

Figure 5-1 Cycle time of the analog input module

Reference

Information on the conversion times can be found in the technical data of the *manual* for the relevant analog electronic module.

5.5 Reaction times of analog output modules

Conversion time

The conversion time of the analog output channels comprises the time for the transfer of the digitized output values from internal memory and the digital/analog conversion.

Cycle time

The conversion of the analog output channels for the module takes place with a processing time and sequentially with a conversion time for channels 0 and 1.

The cycle time, i.e. the time until an analog output value is converted again, is the sum of the conversion times of all the activated analog output channels and of the processing time of the analog output module.

The following figure provides you with an overview of what makes up the cycle time for an analog output module.

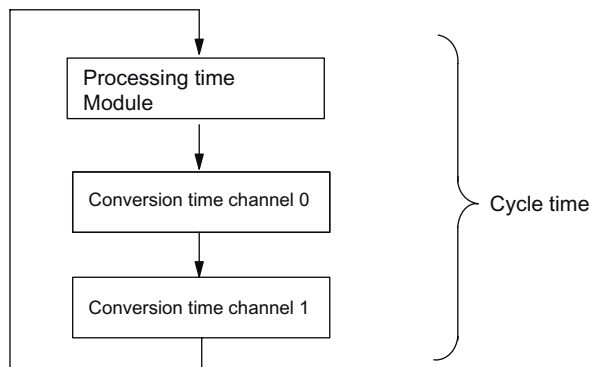

Figure 5-2 Cycle time of the analog output module

Settling time

The settling time (t_2 to t_3) i.e. the time from the application of the converted value until the specified value is obtained at the analog output - depends on the load. A distinction must be drawn between resistive, capacitive, and inductive loads.

Response time

The response time (t_1 to t_3) i.e., the time from the application of the digital output values in internal memory until the specified value is obtained at the analog output - is, in the most unfavorable case, the sum of the cycle time and the settling time. The most unfavorable case is when the analog channel is converted shortly before the transfer of a new output value and is not converted again until after the conversion of the other channels (cycle time).

This figure shows the response time of an analog output channel:

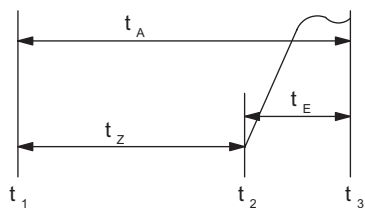

Figure 5-3 Response time of an analog output channel

t_A	Response time
t_z	Cycle time, corresponding to the processing time of the module and the conversion time of the channel
t_E	Settling time
t_1	new digital value applied
t_2	output value transferred and converted
t_3	specified output value obtained

Reference

Information on the conversion times can be found in the technical data of the *manual* for the relevant analog electronic module.

5.6 Response times for a 4 IQ-SENSE electronic module

The response time of the 4 IQ-SENSE electronic module is specified as a cycle time in the Technical Data.

5.7 Response times for technology modules

The response times of the technology modules are specified as response time or update rate in the Technical Data. See *ET 200S Technological Functions Manual*.

Connection

6.1 Connecting interface module IM151-3 PN FO with PROFINET IO interface (optical)

Introduction

Connect the supply voltage to the interface module IM151-3 PN FO using a 2-pin connector and the fiber-optic cable for the PROFINET connection using SC RJ connectors.

Preconditions

- Wire the interface module with the supply voltage switched off.
- Follow the wiring rules.

Tools required

3 mm screwdriver

Required accessories (see *Order numbers*)

- Connectors for PROFINET connection: IE SC RJ POF Plug
- Fiber-optic cable:
 - IE POF standard cable
 - IE POF trailing cable

Rules for configuring a fiber-optic cable network with IM151-3 PN FO

In fiber-optic networks with nodes with integrated fiber-optic interfaces:

- The fiber-optic network can only be configured as a line.
- If you remove the fiber-optic cable from an integrated fiber-optic interface or the supply voltage to the IM151-3 PN FO fails, all subsequent nodes will no longer be accessible.
- The fiber-optic cable may have the following maximum lengths:
 - IE POF standard cable: 50 m
 - IE POF trailing cable: 50 m

6.1 Connecting interface module IM151-3 PN FO with PROFINET IO interface (optical)

Preparing fiber-optic cables with connectors

Prepare the IE POF cable with the connectors IE SC RG POF plug.

Complete instructions are available in the *POF Fiber-Optic Cables with Connectors IE SC RJ POF Plug* (A5E00351141) installation instructions.

Bending radius for the fiber-optic cable

When installing the fiber-optic cable, ensure that the permissible bending radius is not exceeded:

- IE POF standard cable: 150 mm
- IE POF trailing cable: 60 mm

Refer also to the installation guidelines for fiber-optic cable in the *ET 200 Distributed I/O System* or *SIMATIC NET - PROFIBUS Networks* manual.

Reusing fiber-optic cable

Note

If reusing fiber-optic cable, you must shorten both fiber-optic cores by the amount of the curved lengths and reinstall the connectors. This will prevent any attenuation losses caused by re-bent, heavily-stressed portions of the fiber-optic core.

Connecting interface module IM151-3 PN FO to PROFINET IO

1. Remove the blind plugs of the PROFINET connections.
2. Hold the preassembled connector by the **housing** and push it into the PROFINET socket until it audibly engages. The connectors are coded to ensure safe connection.

If the IM151-3 PN FO is the last node of the fiber-optic cable network, then you have to connect the unused fiber-optic interface with a blind plug. The blind plugs go into the PROFINET sockets of the IM151-3 PN FO in the delivery condition.

 CAUTION

Do not look directly into the opening of the optical transmit diodes. The emitted light beam can damage your eyes.

6.2 Connecting the voltage supply

Introduction

The voltage supply is over a connecting plug. The connecting plug is plugged into the voltage supply connection on the IM151-3 PN FO in delivery condition.

The connecting plug makes it possible to loop the voltage supply uninterrupted.

Tools required

3 mm screwdriver

Power supply unit

You must only use PELV-type power supply units with protective extra-low voltage with safe electrical isolation (\leq DC 60 V).

Connector for power supply

The voltage supply connection for the 24V voltage supply is located on the front of the IM151-3 PN FO. The maximum cross-section of the connection is 2.5 mm². The connections have the following functions:

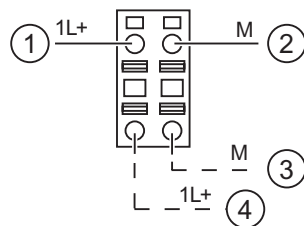

- ① + 24V DC (red)
- ② Ground (blue)
- ③ Ground (blue)
- ④ + 24V DC (red)

Procedure

1. Strip the wire to a length of 10 mm.
2. Insert the wire as far as it will go into the round opening of the connecting plug. Insert the connecting plug in delivery condition into the voltage supply connection.
3. Insert the wired connecting plug into the voltage supply connection on the IM151-3 PN FO.
4. Please ensure that there is sufficient strain relief.

Order numbers

Accessories for fiber-optic cable technology

Table A-1 Order numbers of accessories

Description	Order No.:
IE Termination Kit SC RJ POF Plug Assembly case for on-site installation of SC RJ POF connectors; consisting of stripping tool, Kevlar scissors, SC RJ grinding disk, grinding paper, grinding base and microscope	6GK1 900-0ML00-0AA0
IE SC RJ POF plug Cable connector (20 units)	6GK1 900-0MB00-0AC0
SC RJ Refill Set POF Refill Set for Termination Kit SC RJ POF Plug consisting of grinding paper and grinding disk (5 units)	6GK1 900-0MN00-0AC0
IE POF Standard Cable GP 980/1000, cut-to-length	6XV1874-2A
IE POF Trailing Cable 980/1000, cut-to-length	6XV1874-2B

For the technical data of the fiber-optic cables, please refer to IKPI 2006.

Index

A

Accessories, 45

B

Basic knowledge requirements, 3
Block diagram, 9

C

Channel diagnostics, 26
Compatibility, 8
Configuration
 Ports, 19
Connecting PROFINET IO, 42
Connection
 Interface module IM151-3 PN FO, 41
Conversion time, 38
Cycle time, 37, 38

D

Diagnostics, 25
 after recovery of the IO device, 31
 after STOP IO controller, 31
Diagnostics readout, 25
Disposal, 3

E

Evaluating interrupts with IO controller, 33

F

Fiber-optic error, 32
Firmware update, 14
FOC
 bending radius, 42

I

Identification data, 17
Internet
 Service & Support, 4

L

LED display, 21
Load voltage
 Failure, 31
Load voltage failure, 31
Loss of synchronization, 32

M

Maintenance interrupts
 Fiber-optic error, 32
 Loss of synchronization, 32
 Network error, 32

N

Network error, 32

O

Options, 25

P

Parameters, 15
Pin assignment, 9
Plug connector
 Making, 42
Ports, 19
Properties, 7

- R**
- Recovery of the IO device
 - Diagnostics events triggered, 31
- Recycling, 3
- Response time, 39
- Response times
 - 4 IQ-SENSE, 39
 - analog input modules, 37
 - analog output modules, 38
 - digital input modules, 36
 - digital output modules, 36
 - Technological modules, 39
- Rules for fiber-optic cable network, 41

- S**
- Scope
 - Manual, 3
- Service & Support, 4
- Settling time, 38

- SIMATIC Micro Memory Card, 12
 - Service life, 13
- SIMATIC Micro Memory Cards
 - Order numbers, 13
- SNMP, 11
- Status and error displays, 22
- STEP 7, 25
- STOP IO controller
 - Diagnostics events triggered, 31

- T**
- Technical data, 10
- Technical Support, 4
- Training center, 4

- V**
- Voltage supply
 - Connecting, 43