

SIEMENS

SIMATIC HMI

HMI device KP8, KP8F, KP32F

Operating Instructions

Preface

Overview	1
Safety instructions and approvals	2
Planning the use	3
Mounting and connecting the HMI device	4
Operator controls and displays	5
Assigning parameters for the HMI device in STEP 7	6
Fail-safe operation of KP8F and KP32F	7
HMI device maintenance and repair	8
Technical specifications	9
Appendix	A
List of abbreviations	B

Legal information

Warning notice system

This manual contains notices you have to observe in order to ensure your personal safety, as well as to prevent damage to property. The notices referring to your personal safety are highlighted in the manual by a safety alert symbol, notices referring only to property damage have no safety alert symbol. These notices shown below are graded according to the degree of danger.

⚠ DANGER
indicates that death or severe personal injury will result if proper precautions are not taken.
⚠ WARNING
indicates that death or severe personal injury may result if proper precautions are not taken.
⚠ CAUTION
with a safety alert symbol, indicates that minor personal injury can result if proper precautions are not taken.
CAUTION
without a safety alert symbol, indicates that property damage can result if proper precautions are not taken.
NOTICE
indicates that an unintended result or situation can occur if the relevant information is not taken into account.

If more than one degree of danger is present, the warning notice representing the highest degree of danger will be used. A notice warning of injury to persons with a safety alert symbol may also include a warning relating to property damage.

Qualified Personnel

The product/system described in this documentation may be operated only by **personnel qualified** for the specific task in accordance with the relevant documentation, in particular its warning notices and safety instructions. Qualified personnel are those who, based on their training and experience, are capable of identifying risks and avoiding potential hazards when working with these products/systems.

Proper use of Siemens products

Note the following:

⚠ WARNING
Siemens products may only be used for the applications described in the catalog and in the relevant technical documentation. If products and components from other manufacturers are used, these must be recommended or approved by Siemens. Proper transport, storage, installation, assembly, commissioning, operation and maintenance are required to ensure that the products operate safely and without any problems. The permissible ambient conditions must be complied with. The information in the relevant documentation must be observed.

Trademarks

All names identified by ® are registered trademarks of Siemens AG. The remaining trademarks in this publication may be trademarks whose use by third parties for their own purposes could violate the rights of the owner.

Disclaimer of Liability

We have reviewed the contents of this publication to ensure consistency with the hardware and software described. Since variance cannot be precluded entirely, we cannot guarantee full consistency. However, the information in this publication is reviewed regularly and any necessary corrections are included in subsequent editions.

Preface

Purpose of the operating instructions

This operating manual provides information for manuals derived from the requirements for mechanical engineering documentation according to DIN EN 62079. This information relates to the place of use, transport, storage, mounting, use and maintenance.

These operating instructions are intended for:

- Project planning engineers
- Users
- Commissioning engineers
- Maintenance personnel

Pay particular attention to the chapter "Safety Instructions (Page 23)".

Required knowledge

General knowledge of automation technology and process communication is needed to understand the operating instructions.

It is also assumed that those using the manual have experience in using personal computers and an understanding of Microsoft operating systems.

You must have knowledge about the STEP 7 software and about safety-related technology.

Scope

The operating instructions applies to the following HMI devices:

- KP8, order number 6AV3688-3AY36-0AX0
- KP8F, order number 6AV3688-3AF37-0AX0
- KP32F, order number 6AV3688-3EH47-0AX0

Note

The manual is part of the HMI device and will be required for repeat commissioning. Retain all enclosed and additional documents for the entire service life of the HMI device.

You must pass on all these documents to future owners of the HMI device.

Registered trademarks

The following designations marked with the protective note ® are registered trademarks of the Siemens AG:

- HMI®
- SIMATIC®
- WinCC®

Notes on fail-safe operation

The following sections of these operating instructions contain important information about the fail-safe operation of the KP8F and the KP32F:

- Safety instructions and approvals (Page 23)
- Requirements for fail-safe operation (Page 42)
- Connecting the HMI device (Page 48)
- KP8F – Setting the fail-safe properties (Page 77)
- Fail-safe operation of KP8F and KP32F (Page 95)
- KP8F – Encoder evaluation of the fail-safe channels (Page 117)
- KP32F – Sensor evaluation of the fail-safe channels (Page 122)

Documentation for fail-safe systems

- System description "Safety technology in SIMATIC S7"
 - Provides general information on the use, structure, and mode of operation of the fail-safe automation systems S7 Distributed Safety and S7 F/FH Systems
 - Contains detailed technical information which can be represented for the fail-safe technology both in S7-300 and S7-400.
 - Contains information about the calculation of monitoring and reaction times of the fail-safe systems "S7 Distributed Safety" and of "S7 F/FH Systems".
- "S7 Distributed Safety, Configuring and Programming" Manual and Online Help
 - Describes the configuration of the F-CPU and of the fail-safe I/O and the programming of the F-CPU in F-FBD or F-LAD
- "Automation System S7-1200, CPU Data" Reference Manual
 - Describes the standard functions of the CPU 1211C, CPU 1212C and CPU 1214C.
- "Automation System S7-400, CPU Data" Reference Manual
 - Describes the standard functions of CPU 416F-3 PN/DP, CPU 414-3 PN/DP and CPU 416-3 PN/DP.
- "Automation System S7-300, CPU Data" Reference Manual
 - Describes the standard functions of CPU 315F-2 PN/DP, CPU 317F-2 PN/DP, CPU 315-2 PN/DP and CPU 317-2 PN/DP.

Style conventions

This manual uses the following style conventions:

Style Convention	Scope
"Add screen"	<ul style="list-style-type: none"> Terminology in the user interface, for example dialog names, tabs, buttons, menu commands Required input, for example, limits, tag values. Path information
"File > Edit"	Operational sequences, for example, shortcut menu commands
<F1>, <Alt+P>	Keyboard operation

Please observe notes labeled as follows:

Note

A note contains important information about the product described in the manual and its use, or a specific section of the manual to which you should pay particular attention.

Naming conventions

This manual uses the following naming conventions:

Naming convention	Applies to
Plant	<ul style="list-style-type: none"> System Machining center One or more machines
Actuate	<ul style="list-style-type: none"> By means of the touch screen on the HMI device By means of the button on the HMI device By operating a mouse on the HMI device
Switching cabinet	<ul style="list-style-type: none"> Mounting cabinet Switching cabinet Switchboard Console

Figures

This manual contains illustrations of the described devices. The illustrations can deviate from the details of the delivered device.

Technical Support

Technical support for the products covered in the manual is available in the Internet at:

- Technical Support (http://www.siemens.de/automation/csi_en_WW)
- Support Request (<http://www.siemens.com/automation/support-request>)
- Service (<http://support.automation.siemens.com/WW/view/en/16604318>)
- Contacts and office locations
(<http://www.automation.siemens.com/mcms/aspa-db/en/Pages/default.aspx>)
- Training center (<http://sitrain.automation.siemens.com/sitrainworld/?AppLang=en>)

Additional information on SIMATIC products is available in the Internet at:

- Industry Portal (http://www.automation.siemens.com/_en/portal/index.htm)
- Overall SIMATIC documentation (<http://www.siemens.com/simatic-tech-doku-portal>)

Recycling and disposal

The HMI devices described in these operating instructions can be recycled due to the low levels of pollutants. Contact a certified disposal service company for environmentally sound recycling and disposal of your old devices.

Table of contents

	Preface	3
1	Overview.....	11
1.1	Product Overview.....	11
1.2	Scope of delivery	11
1.3	Design of KP8 and KP8F	12
1.4	Structure of the KP32F	15
1.5	Accessory kit.....	17
1.6	Service packages.....	17
1.7	Performance features	18
1.8	Communication and enabled PLCs	19
1.9	Fail-safe operation of KP8F and KP32F	20
2	Safety instructions and approvals	23
2.1	Safety Instructions	23
2.2	Approvals	25
2.3	TÜV certificate.....	27
2.4	Notes about Usage	27
2.5	Electromagnetic compatibility	30
3	Planning the use.....	33
3.1	"Plan use" check list.....	33
3.2	Ambient conditions for storage and transport.....	33
3.3	Ambient conditions for operation	35
3.4	Mounting Positions and Type of Fixation.....	37
3.5	Preparing for Mounting	38
3.6	Insulation resistance, protection class and degree of protection.....	41
3.7	Requirements for fail-safe operation.....	42
3.7.1	Sensor for 1oo1 mode	42
3.7.2	Sensor for 1oo2 mode	43
3.7.3	Cables	45

4	Mounting and connecting the HMI device	47
4.1	"Mounting and connection of HMI device" checklist	47
4.2	Check the scope of delivery	47
4.3	Mounting the HMI device	47
4.4	Connecting the HMI device	48
4.4.1	Connection sequences and lines	48
4.4.2	Ports	49
4.4.3	Connecting functional grounding at the KP32F	50
4.4.4	Connecting the power supply	52
4.4.5	Connect standard inputs/outputs	54
4.4.6	Connecting KP8F - fail-safe inputs	55
4.4.6.1	General.....	55
4.4.6.2	Connecting the EMERGENCY STOP button.....	55
4.4.6.3	Fail-safe connection of sensor.....	57
4.4.7	Connecting KP32F - fail-safe inputs	58
4.4.7.1	General.....	58
4.4.7.2	Connecting the EMERGENCY STOP button.....	58
4.4.7.3	Fail-safe connection of sensor.....	60
4.4.8	Connecting the PLC.....	61
4.5	Switching on and testing the HMI device.....	63
4.6	Securing the cables.....	64
5	Operator controls and displays	65
5.1	Front-sided control elements and displays	65
5.2	Rear operator controls and displays	66
5.3	Labeling keys	68
6	Assigning parameters for the HMI device in STEP 7	71
6.1	Checklist "Assign parameters for the HMI device".....	71
6.2	Integrating GSDML in STEP 7	71
6.3	KP8 and KP8F	74
6.3.1	Assigning parameters for the KP8 and KP8F	74
6.3.2	Setting the properties for PROFINET	75
6.3.3	Setting the properties of the digital inputs/outputs.....	76
6.3.4	KP8F – Setting the fail-safe properties	77
6.3.5	KP8F – Configure Shared Device	80
6.3.6	KP8F – Configure Shared Device for non fail-safe controller	82
6.4	KP32F	84
6.4.1	Assign parameters for KP32F	84
6.4.2	Setting the properties for PROFINET	85
6.4.3	Setting the properties and addresses of the lights and buttons.....	85
6.4.4	Setting the properties of the digital inputs.....	87
6.4.5	Setting the properties of the digital inputs/outputs.....	88
6.4.6	Setting the fail-safe properties	89
6.5	Setting the PROFIsafe address	92
6.6	Assigning parameters for Media Redundancy Protocol and Isochronous Real-Time	94

7	Fail-safe operation of KP8F and KP32F	95
7.1	Overview	95
7.2	Passivate HMI device	96
7.3	Error diagnostics	97
7.4	Repair error and reintegrate.....	99
7.5	Response times of the PROFIsafe devices	100
8	HMI device maintenance and repair	103
8.1	Service	103
8.2	Spare parts and repairs	104
9	Technical specifications.....	105
9.1	Dimension drawing KP8, KP8F.....	105
9.2	Dimension drawing KP32F	106
9.3	Technical specifications	107
9.4	Fail-safe mode	109
9.5	Interface description.....	112
9.5.1	KP8, inputs/outputs.....	112
9.5.2	KP8F, inputs/outputs.....	113
9.5.3	KP32F	114
9.5.3.1	Power supply.....	114
9.5.3.2	Inputs	114
9.5.3.3	Input and outputs	114
9.5.4	PROFINET	115
9.6	KP8 and KP8F - Bit assignment in the process image.....	116
9.7	KP8F – Encoder evaluation of the fail-safe channels	117
9.8	KP32F - Bit assignment in the process image.....	119
9.9	KP32F – Sensor evaluation of the fail-safe channels	122
A	Appendix.....	125
A.1	ESD guideline	125
B	List of abbreviations.....	127
	Glossary	129
	Index.....	133

Overview

1.1 Product Overview

Application scenarios of the HMI device

The HMI device shows you operating states of a plant. You can actively control a running production process based on this information.

The HMI device is designed for mounting in control panels, and replaces keys and LEDs that are individually mounted. The HMI device is connected via PROFINET to a SIMATIC controller.

The HMI device is parameterized for immediate use. In comparison to conventional wiring, substantially less time is needed for commissioning and the device provides increased security against failure during runtime.

The KP8 and the KP8F are intended for installation in the following extension units:

- Extension Unit 15", Order number 6AV7674-0KG00-0AA0
- Extension Unit 19" left, order number 6AV7674-0KH00-0AA0
- Extension Unit 19" right, order number 6AV7674-0KJ00-0AA0

Fail-safe operation with KP8F and KP32F

Thanks to the integrated PROFIsafe communication, the HMI device can be used in fail-safe mode for simple sensor applications. In regards to the safety-relevant signals, safety categories SIL3, Performance Level e and category 4 are reached.

1.2 Scope of delivery

The scope of delivery includes:

- 1 HMI device
- 1 accessory kit
- 1 data carrier with ATEX handbook

1.3 Design of KP8 and KP8F

Front view and side view

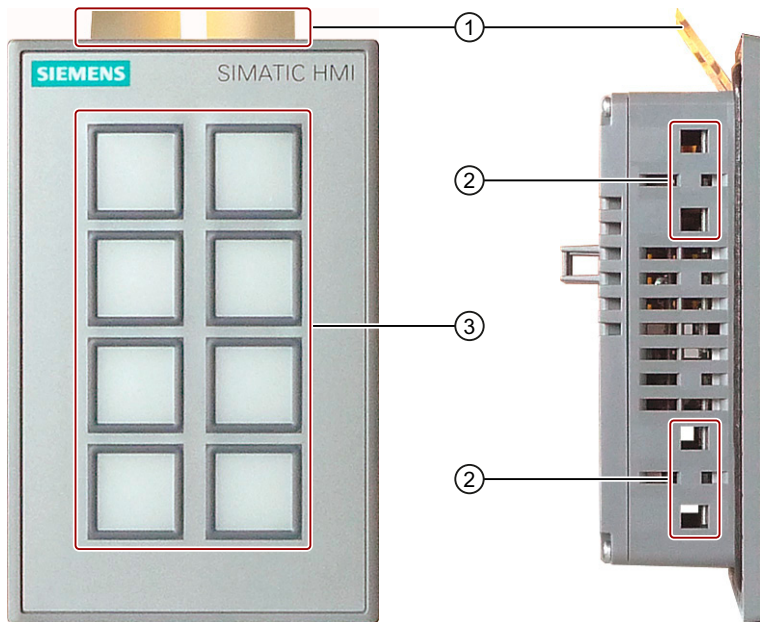

- ① Labeling strips
- ② Oblong holes for a mounting clamp
- ③ Keyboard

Plan view

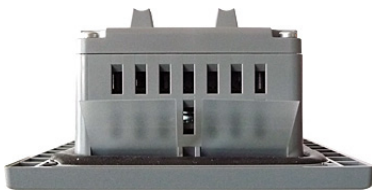

Rear view KP8

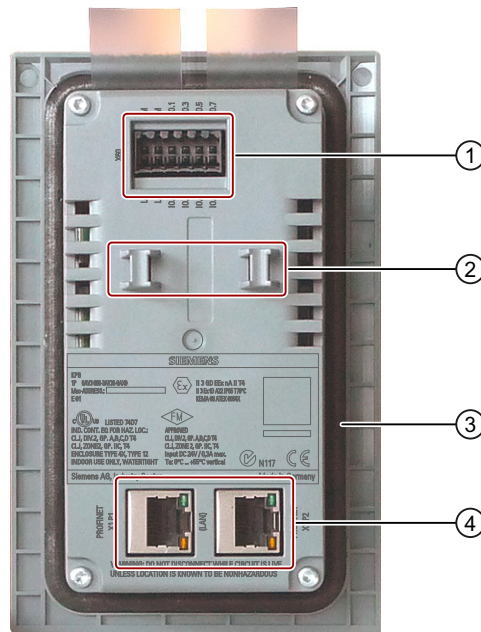

- ① Power supply connection and digital inputs and outputs
- ② Bar for strain relief
- ③ Seal
- ④ PROFINET interfaces

Rear view KP8F

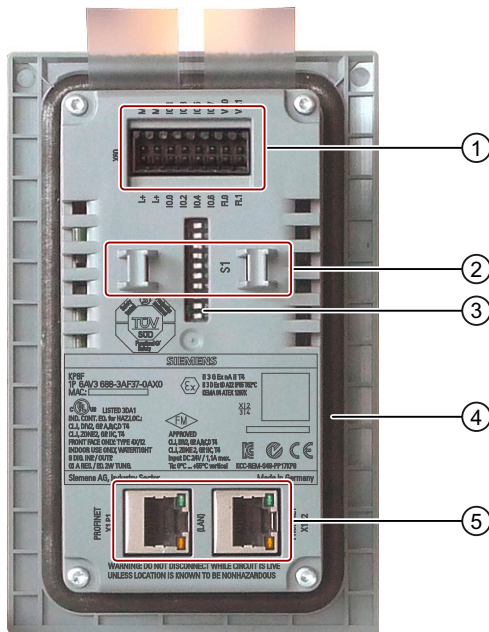

- ① Power supply connection and digital inputs and outputs
- ② Bar for strain relief
- ③ DIP switch
- ④ Seal
- ⑤ PROFINET interfaces

1.4 Structure of the KP32F

Front view and side view

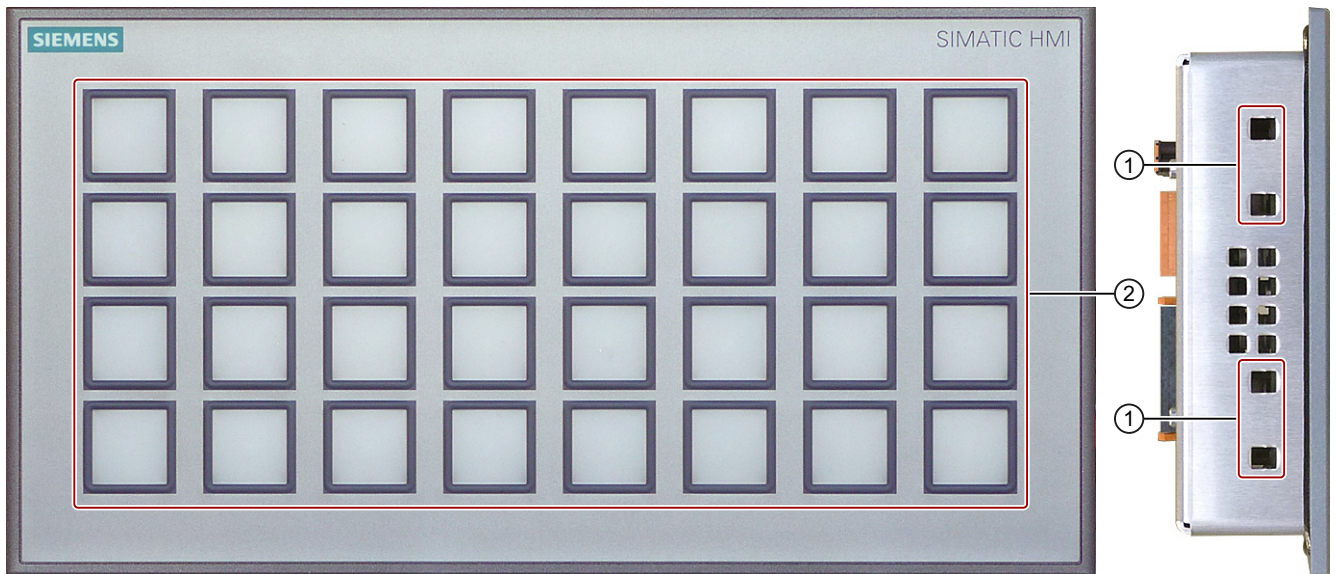

- ① Oblong holes for a mounting clamp
- ② Keyboard

Plan view

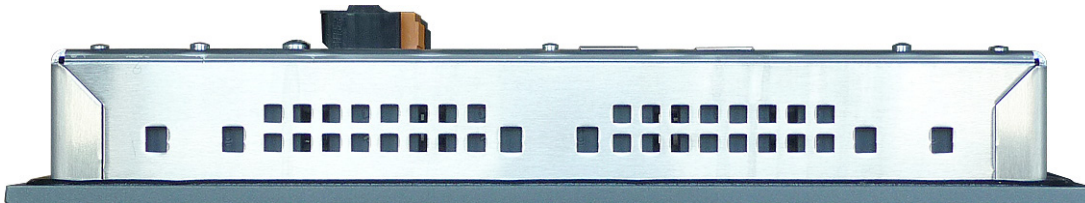

Rear view

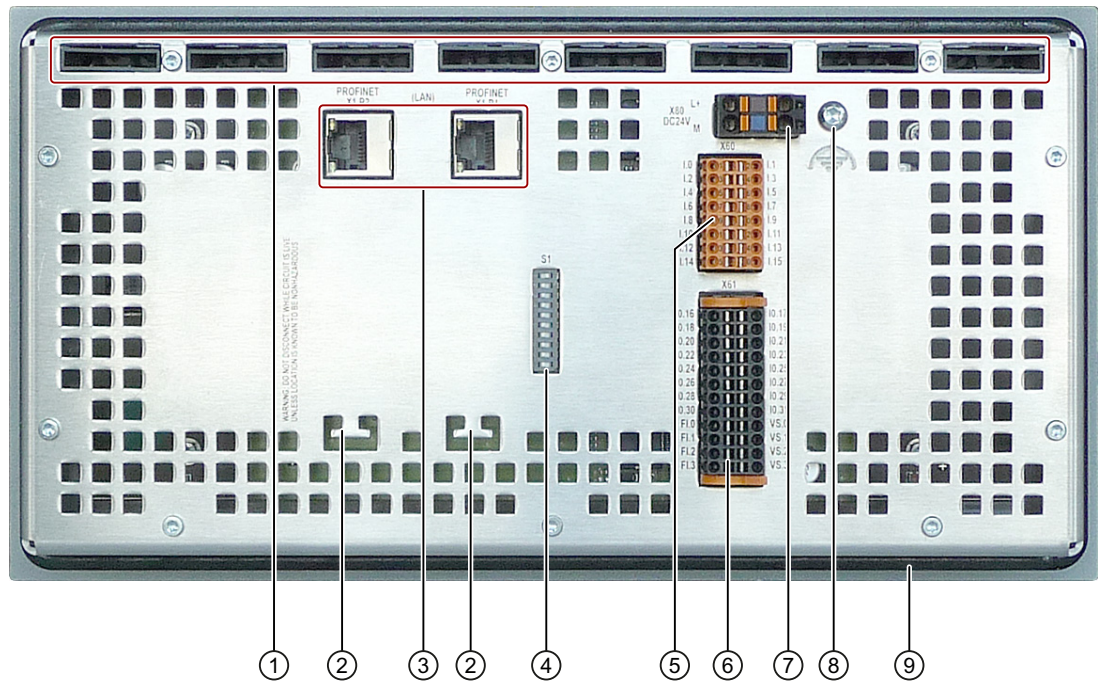

- ① Openings for labeling strips
- ② Bar for strain relief
- ③ PROFINET interfaces
- ④ DIP switch
- ⑤ Connector for the digital inputs
- ⑥ Connector for the digital inputs/outputs
- ⑦ Connector for the power supply connection
- ⑧ Connection for the functional grounding
- ⑨ Seal

1.5 Accessory kit

Device	Content of the accessory kit
KP8	<ul style="list-style-type: none"> • A 12-pin plug connector • Four mounting clamps for mounting the HMI device
KP8F	<ul style="list-style-type: none"> • A 16-pin plug connector • Four mounting clamps for mounting the HMI device
KP32F	<ul style="list-style-type: none"> • One mains terminal • A 16-pin plug connector • A 24-pin plug connector • 10 mounting clamps for mounting the HMI device

The accessory kit can include documents.

1.6 Service packages

KP8

This service pack contains:

1 set connector, 12-pin, order number 6AV6671-3XY39-4AX0

KP8F, KP32F

This service pack contains:

1 set connector, 16-pin, order number 6AV6671-3XY49-4AX0

KP8, KP8F, KP32F

This service pack contains:

1 set plastic mounting clamps, order number 6AV6671-8XK00-0AX2

KP32F

The service packs contain:

- 1 connector, 24-pin, order number 6AV6671-3XY58-4AX0
- 2 mains supply terminals, 2-pin, order number 6ES7193-4JB00-0AA0

1.7 Performance features

Performance features KP8

The HMI device offers a wide range of features:

- 8 short-stroke keys with integrated LEDs

The LEDs allow for the display of different colors. The colors red, yellow, blue, green and white are displayable.

- 8 clamps, rear

The clamps are used as digital inputs or outputs to the connection of external sensors.

- Integrated light and button tests - after turning on the HMI device
- Communication via PROFINET
- SIMATIC design

Through this, the HMI devices can be arranged closely next to each other.

Expansion with external input/output devices

The functionality of the HMI device can be extended using input and output devices, for example lamps or key switches.

Performance features KP8F

The KP8F has the following additional performance features compared to the KP8:

- Fail-safe digital inputs for:
 - An EMERGENCY STOP button or alternatively
 - Two single-channel evaluations

Performance features KP32F

The HMI device offers a wide range of features:

- 32 short-stroke keys with integrated LEDs
The LEDs allow for the display of different colors. The colors red, yellow, blue, green and white are displayable.
- 32 clamps, rear
16 terminals to be used as digital inputs and 16 terminals as digital inputs or outputs for connection of external encoders and sensors.
- Integrated light and button tests - after turning on the HMI device
- Communication via PROFINET
- SIMATIC design
Through this, the HMI devices can be arranged closely next to each other.
- 4 fail-safe digital inputs for:
 - Two EMERGENCY STOP buttons or alternatively
 - four single-channel evaluations

1.8 Communication and enabled PLCs

Enabled PLCs

The HMI device has been enabled for operation with the following type of controllers:

- SIMATIC S7-1200
- SIMATIC S7-400, SIMATIC S7-400F
- SIMATIC S7-300, SIMATIC S7-300F
- WinAC and Embedded Controllers

NOTICE
Safety-related communication
A non fail-safe controller does not provide any safety-directed communication. A SIMATIC S7F controller is required for fail-safe communication.

Released protocols

The HMI device uses the following protocols for communication with the controller:

- PROFINET IO for standard communication
- PROFIsafe Mode V2.0 for fail-safe communication of the KP8F and KP32F

1.9 Fail-safe operation of KP8F and KP32F

Configuring software

For fail-safe operation of the HMI device, the following software is required:

- STEP 7 V5.5 and higher
- SIMATIC S7 Distributed Safety, as of V5.4

Fail-safe automation system

A fail-safe automation system (F System) is used in plants with increased safety requirements.

An F system controls production processes so that residual error probability is taken into consideration to achieve a safe operating state when a shutdown occurs. An immediate shutdown therefore does not pose a danger to people or the environment.

Configuration example of an F system with KP8F and KP32F

The following example shows fail-safe and non-fail safe devices in a computer network.

SIMATIC S7-416F-3 PN/DP
as PROFINET IO controller

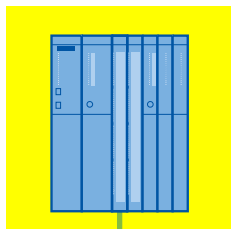

Standard Host/SPS
as PROFINET IO controller



ET 200S station
with
IM 151-3 PN

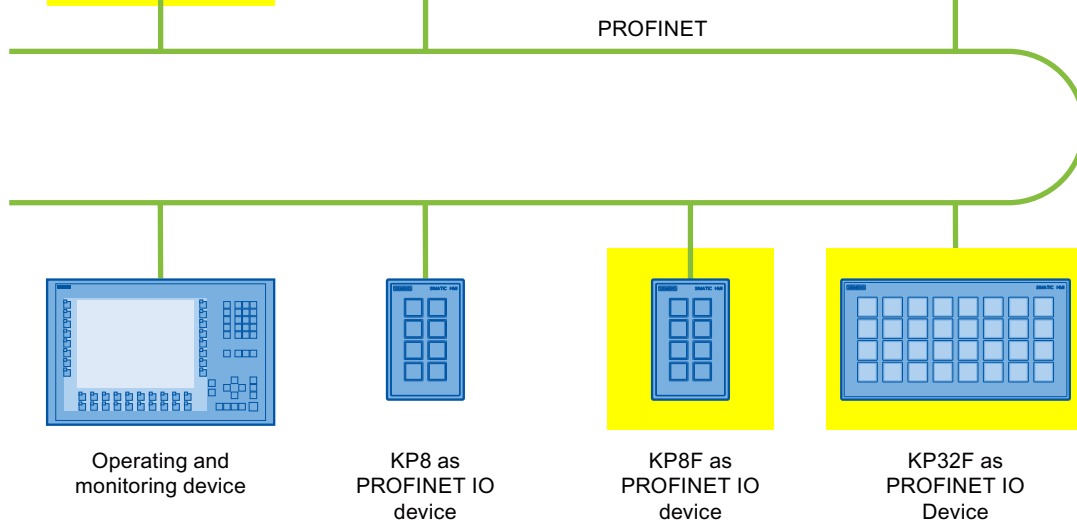

In the example, each PROFINET IO device communicates with just one PROFINET IO-controller. The PROFIsafe device communicates here exclusively with the F-PROFINET IO controller.

Fail-safe operation of KP8F and KP32F

KP8F and KP32F are PROFINET IO devices in an Industrial Ethernet.

In fail-safe mode the HMI device registers the signal states of compatible emergency stop buttons and transmits corresponding safety frames to the controller. The controller and the HMI device communicate with each other using the fail-safe protocol, PROFIsafe.

The HMI device can operate in fail-safe mode corresponding to SIL3, Performance Level e and category 4 if the safety functions are appropriately configured in STEP 7 with the "S7 Distributed Safety" add-on package.

Fail-safe mode of the HMI devices differs from standard mode essentially in that during communication, the signals are checked for being fault-free. In the event of a fault, the HMI device is placed in a safe state.

The fail-safe connection fulfills the following requirements:

- Single-channel mode with 1oo1 parameterization
 - Safety category SIL2 corresponding to IEC 61508
 - Safety category Performance Level d corresponding to IEC 13849-1
 - Safety category category 3 corresponding to EN 954:1996
- Two-channel mode with 1oo2 parameter assignment
 - Safety category SIL3 corresponding to IEC 61508
 - Safety category Performance Level e corresponding to IEC 13849-1
 - Safety category category 4 corresponding to EN 954:1996

Diagnostic function of KP8F and KP32F

KP8F and KP32F offer non-programmable diagnostics functions. The diagnostics functions are always active. The diagnostics result is automatically made available by the HMI device in STEP 7 and passed on to the fail-safe controller in the event of a fault.

Safety instructions and approvals

2.1 Safety Instructions

 WARNING
Injury or material damage If you do not follow precisely the safety guidelines and manuals in this handbook, this may result in sources of danger and make safety functions ineffective. This can result in personal injuries or material damage. Follow the safety guidelines and instructions precisely.

Observe the safety and accident prevention instructions applicable to your application in addition to the safety instructions given in this manual.

Project security

 WARNING
Injury or material damage The configuration engineer for a system controller must take precautions so that an interrupted program can be restarted normally after voltage dips or power failures. A dangerous operating state must not occur during the entire process of the control program, also during troubleshooting - also not in the short-run.

Safety during commissioning and operation

 WARNING
Installation according to the instructions Commissioning of the HMI device is forbidden until it has been absolutely ensured that the machine which is to be operated with the HMI device complies with Directive 2006/42/EC. Before commissioning, check to see if the regulations of the directive 2006/42/EC are fulfilled. Open-type resource The HMI device is an open-type resource. This means that the HMI device may only be installed in cabinets that allow the device to be operated from the front side. Access to the control cabinet in which the HMI device is installed should only be possible by means of a key or tool and only for trained and authorized personnel. Danger, high voltage Opening the cabinet will expose high voltage parts. Contact with these parts could be fatal. Switch off the power supply to the cabinet before opening it.

When operating the HMI device in hazardous areas the following warning applies.

 WARNING
Explosion Hazard Do not disconnect while circuit is live unless area is known to be non-hazardous. Substitution of components may impair suitability for Class I, Division 2 or Zone 2.

Safety during operation

Note

High frequency radiation, from mobile phones for example, can cause unintentional operating situations.

Recall

Note

If a safety issue is discovered for the KP8F or the KP32F, customers are immediately informed by the Siemens sales department they ordered from and told about suitable measures.

2.2 Approvals

Note

The following overview shows possible approvals for the HMI device.

The HMI device itself is certified as shown on the label on its rear panel.

CE mark



The HMI device meets the general and safety-related requirements of the following EU directives and conforms to the harmonized European standards for programmable logic controllers published in the official gazettes of the European Union:

- 2004/108/EC "Electromagnetic Compatibility" (EMC Directive)
- 2006/95/EC "Electrical Equipment Designed for Use within Certain Voltage Limits" (Low-voltage Directive)

EC Declaration of Conformity

The EC Declarations of Conformity are kept available for the responsible authorities at the following address:

Siemens AG
Industry Sector
I IA AS FA SYS
Postfach 1963
92209 Amberg
Germany

Explosion protection approval



For the HMI device

- EN 60079-0
- EN 60079-15
- EN 60079-31

the following approvals are in place:

II 3 G	II 3 G Ex nA IIC T4 Gc
II 3 D	II 3 D Ex tc IIIC T 70 °C Dc IP65

The design examination certificate is available at the following Internet address:

Technical Support (http://www.siemens.de/automation/csi_en_WW)

2.2 Approvals

FM approval



"Factory Mutual Research" approval in accordance with Approval Standard Class Number 3611, 3600, 3810

Approved for use in:

- Class I, Division 2, Group A, B, C, D Tx
- Class I, Zone 2, Group IIC Tx

UL approval

Please note the following:

- The device shall be supplied from an isolating source, rated 24 VDC.
- For use on a flat surface of a Type 1, 4X (indoor use only) and 12 Enclosure.
- Only for use in LAN, not for connection to telecommunication circuits.



"Underwriters Laboratories Inc." approval in accordance with:

- UL 508 (Industrial Control Equipment)
- CSA C22.2 No. 142 (Process Control Equipment)

or



"Underwriters Laboratories Inc." approval in accordance with:

- UL 508 (Industrial Control Equipment)
- CSA C22.2 No. 142 (Process Control Equipment)
- UL 1604 (Hazardous Location)
- CSA-213 (Hazardous Location)

Approved for use in:

- Class I, Division 2, Group A, B, C, D or
- Class I, Zone 2, Group IIC or
- Non-hazardous locations

Approval for Australia and New Zealand



The HMI device fulfills the requirements of standard AS/NZS 2064 (Class A).

Approval for Korea



This product meets the requirements of the Generic standards - Emission standard for industrial environments.

2.3 TÜV certificate

The HMI device is certified according to the following standards. The latest edition of the standard can be found in the report for the Technical Inspectorate Certificate.

Safety subject	Standard
Functional safety	IEC 61508:2010
	EN ISO 13849-1:2008
	DIN EN 954-1:1997
Basic safety	DIN EN 61131-2:2007
Machine Safety	EN 60204-1:2006
	NFPA 79:2007
	EN 62061:2005
	IEC 61511:2003
	ISO 13850:2008

You can obtain a copy of certificates and reports from the Technical Inspectorate at the following address:

Siemens AG
 Industry Sector
 I IA AS FA SYS
 Postfach 1963
 92209 Amberg
 Germany

You can find the certificates from the Technical Inspectorate in the Internet at the following address:

"Technical Support (http://www.siemens.de/automation/csi_en_WW)"

2.4 Notes about Usage

The HMI device is designed for industrial use, limit class A. The following standards are met:

- Requirements for emissions EN 61000-6-4:2007
- Requirements for interference immunity DIN EN 61000-6-2:2005

Note

The HMI device is not suitable for operation in residential areas: Operation of an HMI device in residential areas can have a negative impact on radio and TV reception.

If the HMI device is used in a residential area, you must take measures to achieve Limit Class B conforming to EN 55016 for RF interference.

Suitable measures to achieve Limit Class B for suppression of radio interference include:

- Installation of the HMI device in a grounded control cabinet
- Use of filters in electrical supply lines

Individual acceptance is required.

Operation in potentially explosive atmosphere, zone 2 and 22

 DANGER
<p>Degree of hazard</p> <p>There is an explosion hazard when operating an HMI device that does not have explosion protection.</p> <p>Operate the HMI device in potentially explosive zones 2 and 22 only if it has been approved and certified for such environments.</p>

If an HMI device is operated in potentially explosive atmospheres of zone 22, pay attention to the product information "Use in potentially explosive atmospheres of zones 2 and 22." The product information is available at the following Internet address:

Technical Support (http://www.siemens.de/automation/csi_en_VW)

 WARNING
<p>Personal injury and damage to property</p> <p>Personal injury and property damage can occur in potentially explosive atmospheres if an electric connection is disconnected from the HMI device while the system is in operation.</p> <p>In potentially explosive atmospheres, always turn off power to the HMI device before disconnecting any electrical connections..</p>

Potentially explosive atmosphere zones 2 and 22

Areas subject to explosion hazard are divided into zones. The zones are differentiated according to the probability of the existence of an explosive atmosphere.

Zone	Degree of hazard	Example
2	Explosive gaseous atmosphere occurs only seldom and for a short period	Areas around flanged pipe joints with flat gaskets in closed rooms
22	Area in which a potentially explosive atmosphere in the form of a cloud in the air containing flammable dust does not usually occur or occurs only briefly during normal operation .	–
Safe zone	No	<ul style="list-style-type: none"> • Outside zone 2 • Outside zone 22 • Standard applications of distributed I/Os

Operating conditions for zones 2 and 22

The following operating conditions apply for zones 2 and 22:

- The HMI device must be installed in a control cabinet. The control cabinet must meet the following in accordance with EN 60529:
 - Protection type IP54 or higher for Zone 2
 - Protection type IP5x or higher for Zone 22 in case of **non** conductive dust
 - Protection type IP6x or higher for Zone 22 in case of conductive dust

You must install the HMI device so that you provide at least protection type IP54 or IP5x to EN 60529 on the front of the device. Consult the operating instructions of control cabinet and HMI device for this purpose.

Make allowances for the operating and ambient conditions under which you operate the HMI device. A manufacturer's declaration must be provided for the control cabinet in accordance with EC Directive 94/9, stating it is fit for purpose.

- The ambient temperature range is $0\text{ °C} \leq T \leq 55\text{ °C}$. Under these conditions, the HMI device will satisfy temperature class Tx for category 3G and support a maximum surface temperature of xx °C for category 3D. (x ... Temperature value, see design examination certificate).

Refer to the operating instructions for details of limitations resulting from the ambient temperature range.

- In situations where the temperature on the cable at the cable inlet of the control cabinet exceeds a temperature of 70 °C, or where the temperature on the wire branching point exceeds 80 °C under operating conditions, the temperature specifications of the cables must match the actually measured temperatures.
- Put measures in place to ensure the rated voltage is not exceeded.

Any transient interference voltages above the rated value must not exceed 40 %.

- Protect the HMI device from mechanical loads > 4 joule and the display from mechanical loads > 2 joule.
- Ensure that the atmosphere is not explosive during servicing.

Measures that impair or remove the protection type of the HMI device are not permitted while the system is in operation.

- If the HMI device was dismantled, check the mounting seal for damage before reassembling the HMI device. A damaged, porous or used mounting seal no longer meets the requirements of the protection type. In this case, the mounting seal must be replaced.
- Turn off the HMI device and the entire electrical installation in the control cabinet, if the film on the front of the HMI device or the glass of the display on the HMI device are damaged by a tear or hole or if the front film starts to peel off.

Replace the HMI device. Restart the system again after the device has been exchanged.

2.5 Electromagnetic compatibility

The HMI device fulfils, among other things, the requirements of the EMC laws pertaining to the European domestic market.

EMC-compliant installation of HMI devices

An EMC-compliant installation of the HMI device and the use of interference-proof cables form the basis of trouble-free operation. The following documentation applies to the mounting of the HMI device:

- Description "Directives for interference-free installation of PLCs" (<http://support.automation.siemens.com/WW/view/de/1064706>)
- The manual "PROFINET System Description"

Pulseshaped Interference

The following table shows the electromagnetic compatibility of modules compared to pulse-shaped interference. These specifications only apply when the HMI device meets the specifications and directives regarding electrical installation.

Pulse-shaped interference	Tested with	Corresponds to test intensity
Electrostatic discharge conforming to IEC 61000-4-2:2008	Air discharge: 8 kV Contact discharge: 6 kV	3
Bursts (high-speed transient interference) in accordance with IEC 61000-4-4:2004	2 kV power supply cable 2 kV signal cable, > 30 m 1 kV signal cable, < 30 m	3
High-power surge pulses in accordance with IEC 61000-4-5:2005, external protective circuit required (refer to manual S7-300 Automation System, Installation, section "Lightning and overvoltage protection").		
Asymmetric coupling	2 kV power cable DC voltage with protective elements 2 kV signal/data cable, > 30 m, with protective elements as required	3
Symmetric coupling	1 kV power cable DC voltage with protective elements 1 kV signal cable, > 30 m, with protective elements as required	3

Sinusoidal interference

The table below shows the EMC properties of the modules with respect to sinusoidal interference. These specifications only apply when the HMI device meets the specifications and directives regarding electrical installation.

Sinusoidal interference	Test values	Corresponds to test intensity
HF radiation (in electromagnetic fields) in accordance with IEC 61000-4-3:2006	<ul style="list-style-type: none"> • 80% amplitude modulation at 1 kHz with 10 V/m in the range of 80 MHz to 1 GHz with 3 V/m in the range 1.4 GHz to 2 GHz with 1 V/m the range 2 GHz to 2.7 GHz • 10 V/m with 50 % pulse modulation at 900 MHz 10 V/m with 50 % pulse modulation at 1.89 GHz 	3
RF interference current on cables and cable shielding conforming to IEC 61000-4-6:2008	Test voltage 10 V at 80 % amplitude modulation of 1 kHz in the range from 9 kHz to 80 MHz	3

Emission of radio interference

The table below shows the emission values of electromagnetic interference conforming to 55011:2009, limit value class A, Group 1, measured at a distance of 10 m:

30 ... 230 MHz	< 40 dB (V/m) quasi-peak
230 ... 1000 MHz	< 47 dB (V/m) quasi-peak

Note

Before you connect the HMI device to the public power grid, ensure that it is compliant with Limit Class B in accordance with EN 55022:2006.

Planning the use

3.1 "Plan use" check list

Before deploying the HMI device, you should check that the planned operation of the HMI device complies with the following test steps.

Test step	Information	Check
Check climatic and mechanical ambient conditions	Ambient conditions for storage and transport (Page 33)	
Set mounting position, installation location and mounting type of the HMI device	Mounting Positions and Type of Fixation (Page 37)	
Prepare installation cut-out	Preparing for Mounting (Page 38)	
Check insulation voltage, protection class and seal tightness	Insulation resistance, protection class and degree of protection (Page 41)	
Select sensors for fail-safe operation	Requirements for fail-safe operation (Page 42)	
Check compliance with the technical data	Technical specifications (Page 107)	

3.2 Ambient conditions for storage and transport

The shipping conditions of this HMI device exceed requirements in accordance with IEC 61131-2. The following specifications apply to devices that are shipped and stored in the original packaging.

The climatic ambient conditions conform to the following standards:

- IEC 60721-3-3:1994, Class 3K7 for storage
- IEC 60721-3-2:1997, Class 2K4 for transportation

The mechanical ambient conditions are compliant with IEC 60721-3-2:1997, Class 2M2.

3.2 Ambient conditions for storage and transport

In the following table, the tests are contained that were checked on the HMI device in regards to the ambient conditions for transport and storage.

Test	Permitted range
Drop test, in transport package	≤ 1 m
Temperature	-20 to +60 °C
Air pressure acc. to IEC 60068-2-13:1983	1080 to 660 hPa, corresponds to an elevation of -1000 to 3500 m
Humidity, relative	10 to 95 %, without condensation
Vibration, sinusoidal as per IEC 60068-2-6:2007 Test Fc	<ul style="list-style-type: none"> • 5 to 8 Hz, 3.5 mm, 10 cycles per axis • 8 to 500 Hz, 9.8 m/s², 10 cycles per axis
Shock as per IEC 60068-2-27:2008 Test Ea	250 m/s ² , 6 ms, 1000 shocks

<p>NOTICE</p> <p>Equipment failure</p> <p>Moisture and condensation lead to malfunction. Moisture in the form of condensation on or in the device is formed:</p> <ul style="list-style-type: none"> • When transporting a device at low temperatures • Under extreme temperature variations <p>Bring the device to room temperature before operating.</p> <p>Condensation</p> <p>When condensation is on the device, do not expose the HMI device to direct radiation from a heater.</p> <p>If condensation has developed, wait approximately 4 hours until the HMI device has dried completely before switching it on.</p>
--

The following points must be adhered to in order to ensure a fault-free and safe operation of the HMI device:

- Proper transportation and storage
- Proper installation and mounting
- Careful operation and maintenance

The warranty for the HMI device will be deemed void if these stipulations are not heeded.

3.3 Ambient conditions for operation

Mechanical and climatic ambient conditions

The HMI device is designed for operation in a location protected from the effects of the weather. The ambient conditions meet the requirements for IEC 60721-3-3 Edition 2.2:2002:

- Mechanical requirements according to class 3M3
- Climatic requirements according to class 3K3

Operation with additional protective measures

You may only operate the HMI device at the following locations with additional protective measures:

- In locations with a high degree of ionizing radiation
- In locations with difficult operating conditions, for example due to:
 - Corrosive vapors, gases, oils or chemicals
 - Electrical or magnetic fields of high intensity
- In systems that require special monitoring, for example:
 - Elevators
 - Systems in especially hazardous rooms

Damping shock and vibration

If the HMI device is subjected to strong shocks or vibrations - as specified in the following table - you must take appropriate measures to reduce amplitudes or acceleration. In such situations, use vibration damping or vibration absorber systems for the HMI device and accessories.

Testing mechanical ambient conditions

In the following table contains tests that were checked on the HMI device in regards to the ambient conditions for operation.

Test	Physical variable	Value
Vibrations IEC 60068-2-6:2007 Test Fc	Vibration	1 octave/min 10 cycles per axis
	Frequency band	5 to 8.4 Hz Deflection 3.5 mm
		8.4 to 150 Hz Vibration acceleration 9.8 m/s
Shock IEC 60068-2-27:2008 Test Ea	Shock form	Half sine
	Acceleration	150 ms ⁻²
	Duration	11 ms
	Number of shocks	3 per axis
Case DIN EN 60068-2-31:2009 Test Ec	Fall height	0.3 m, five times

Testing climatic ambient conditions

In the following table, contains the tests that were checked on the HMI device in regards to the climatic ambient conditions for operation.

Ambient condition	Permitted range	Comment
Operating temperature	See Mounting Positions and Type of Fixation (Page 37)	–
Humidity, relative IEC 61131-2:2007	< 95 %, No condensation	–
Humidity, absolute	1 to 25 g/m ³	–
Air pressure IEC 60068-2-13:1983	1080 to 795 hPa	Corresponds to an elevation of –1000 to 2000 m
Hazardous material concentration IEC 60721-3-3:1994	SO ₂ < 0.5 vpm, relative humidity < 60%, no condensation	Test: 10 cm ³ /m ³ ; 10 days
	H ₂ S < 0.1 vpm, relative humidity < 60%, no condensation	Test: 1 cm ³ /m ³ ; 10 days

3.4 Mounting Positions and Type of Fixation

Mounting position

The HMI device is designed for mounting in:

- Racks
- Cabinets
- Control boards
- Consoles

In the following, all of these mounting options are referred to by the general term "cabinet".

The HMI device is self-ventilated and approved for vertical and inclined mounting in stationary cabinets.

The following mounting positions are permitted:

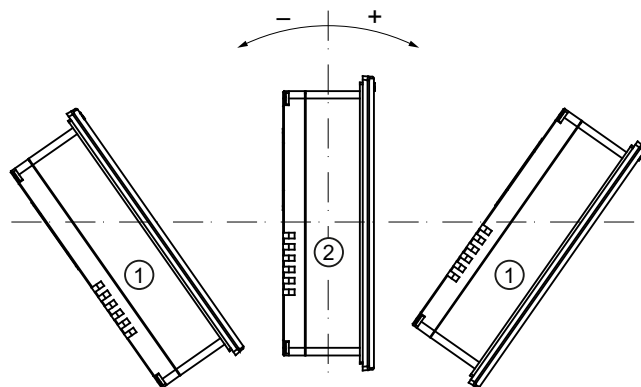

	Mounting position	Device	Orientation	Deviation from the vertical	operating temperature, permissible
①	Inclined	KP8, KP8F	Portrait and landscape format	< 30°	0 to 45 °C
		KP32F	Portrait and landscape format	< 30°	0 to 45 °C
②	Vertical	KP8, KP8F	Portrait and landscape format	0°	0 to 55 °C
		KP32F	Portrait and landscape format	0°	0 to 55 °C

CAUTION

Impermissible ambient temperatures

Do not operate the HMI device without auxiliary ventilation. If the maximum permissible ambient temperature is exceeded, it may lead to damage. The approvals and warranties for the HMI device will become void!

If the maximum permissible ambient temperature is exceeded, only operate the HMI device with auxiliary ventilation.

Type of fixation

Mounting clamps are provided for mounting the device - see section "Accessory kit (Page 17)".

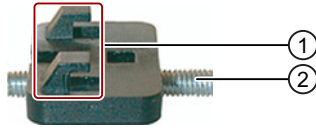

- ① Hooks
- ② Grub screw

The main dimensions of the HMI device are not exceeded by the installation of the mounting clamps.

3.5 Preparing for Mounting

Select the HMI device mounting location

Points to observe when selecting the mounting location:

- Position the HMI device so that it is not subjected to direct sunlight.
- Position the HMI device such that it is ergonomically accessible for the user.
Choose a suitable mounting height.
- Ensure that the air vents are not covered as a result of the mounting.
- Observe the permissible mounting positions for the HMI device.

Configuration of the mounting cut-out

In order to guarantee the protective type corresponding with section "Insulation resistance, protection class and degree of protection (Page 41)", the following must be complied with:

- The material at the mounting cut-out must be distortion-resistant.
- Material thickness at the mounting cutout for IP65 degree of protection or for enclosure type 4X/type 12 (indoor use only): 2 mm up to 6 mm
- Permitted deviation from plane at the mounting cut-out: ≤ 0.5 mm
This condition must be fulfilled for the mounted HMI device.
- Permissible surface roughness in the area of the seal: $\leq 120 \mu\text{m}$ ($R_z 120$)

Dimensions of the mounting cut-out

You can mount several HMI devices flush side-by-side or stacked.

- Mounting cut-out KP8, KP8F

The following figure shows the dimensions of the mounting cut-out and the required distances.

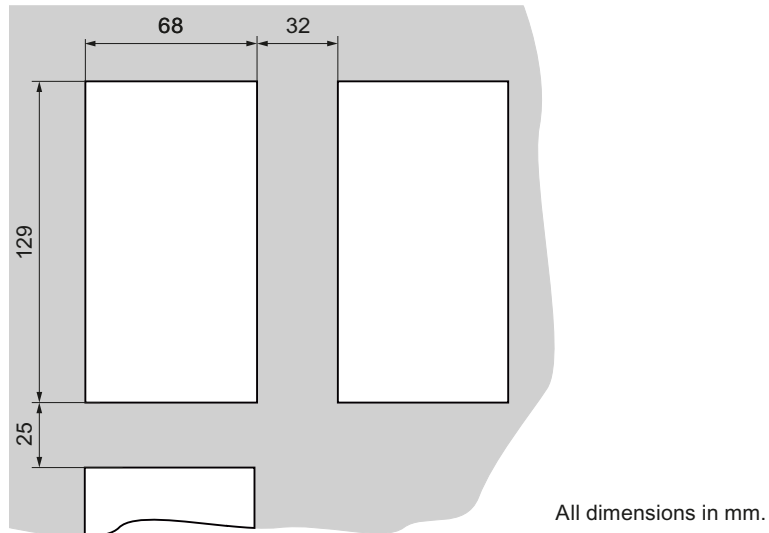

- Mounting cut-out KP32F

The following figure shows the dimensions of the mounting cut-out and the required distances.

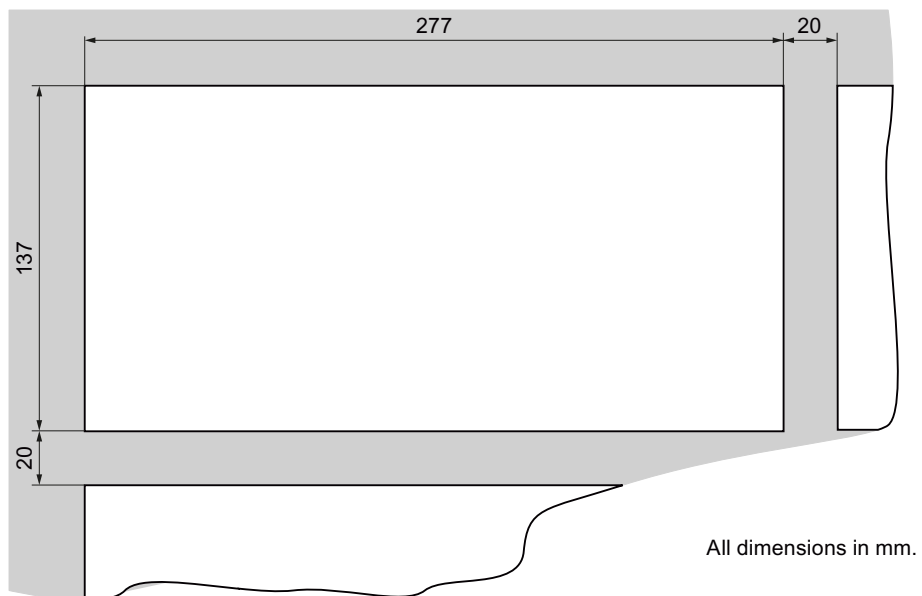

Distances between KP32F and KP8 or KP8F

The following figure shows the required distances for flush-mounting of KP32F and KP8 or KP8F.

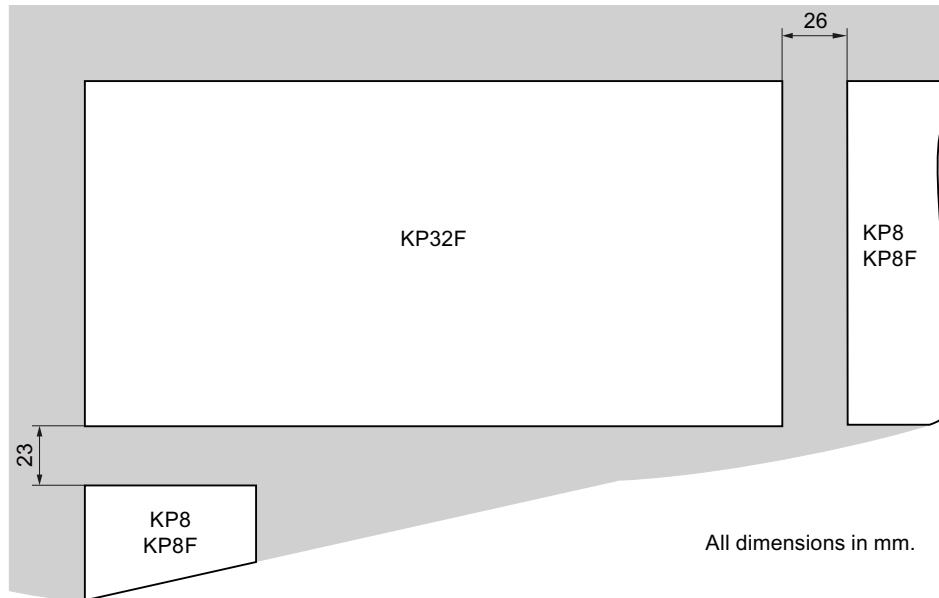

Mounting Depth

The mounting depth for the HMI device depends on the type of construction of the PROFINET connector. With angled PROFINET connector, order number 6GK1901-1BB20-2AB0, the mounting depth is 65 mm.

Plan for an adequate bending radius for the cables connected to the HMI device.

Clearance

Observe the maximum permitted ambient temperature particularly when flush-mounting multiple HMI devices. Make sure that there is sufficient heat dissipation during operation.

3.6 Insulation resistance, protection class and degree of protection

Insulation resistance of the HMI device

Insulation resistance is demonstrated in the type test with the following test voltages in accordance with IEC 61131-2:

Circuits with a nominal voltage of U_n to other circuits or ground	Test voltage
< 50 V	500 VDC

Protection class of the HMI device



HMI device	Protection class according to IEC 60417-DB-HS:2008
Front and rear panel	Protection class III

Degree of protection of the HMI device

NOTICE
<p>Degree of protection IP65 for HMI device</p> <p>If the HMI device is not installed according to this manual, the HMI device does not comply with the specified protection type.</p> <p>Make sure the mounting is done properly. Observe the permitted material thickness at the mounting cut-out.</p>

HMI device	Degree of protection IEC 60529:2000
Front	IP65
Rear	IP20

3.7 Requirements for fail-safe operation

3.7.1 Sensor for 1oo1 mode

The following safety categories can be achieved with the HMI device:

- SIL2 corresponding to IEC 61508
- PL d corresponding to IEC 13849-1
- Category 3 according to EN 954

Note

Have the fail-safe part of the system checked and accepted by a registered company in regards to the prescribed technical safety controls before commissioning the HMI device.

Sensor Requirements for Fail-Safe Sensors

NOTICE
Qualified sensor If you do not use any qualified, normed sensors, the safety categories SIL2, PL d and category 3 will not be reached. Only use qualified sensors corresponding with IEC 60947.

Note

Our electronics are equipped with such safety engineering features so that 98% of the maximum permissible probability of hazardous faults is due to all other components of the safety function. This corresponds to the recommended load division in safety engineering between sensing devices, actuating devices, and electronic switching for input, processing, and output.

The probability of hazardous faults and the rate of occurrence of hazardous faults of a safety function must comply with an upper limit determined by an SIL or PL. For a description of the HMI device, refer to section "Technical specifications (Page 107)".

Proof-test interval

Note the following:

- They have a considerable safety responsibility for the instrumentation with sensors.
- Sensors normally do not survive a proof-test interval of 10 years corresponding with IEC 61508.

The sensors clearly lose their safety.

Note

In order to reach the safety categories SIL2, PL d and category 3, high-quality sensors are required. The sensors used must fulfill the standards EN 60947-5-1:2004 and EN 60947-5-5:1997 (VDE 0660, section 200).

The contacts of the sensors must be weld-resistant in accordance with the standard IEC EN 60947-5. Ensure that the sensor connection is free of short-circuits.

Define an ideal proof-test interval for the used sensor.

Fault detection

Faults can be detected if the following connection errors are present:

- Short-circuit between two sensors
- Short-circuit to DC 24 V

Signal duration

In order to assure accurate detection of the sensor signal by the HMI device, you must ensure that the minimum duration for the sensor signal is adhered to. See section "Technical specifications (Page 107)".

3.7.2 Sensor for 1oo2 mode

The following safety categories can be achieved with the HMI device:

- SIL3 corresponding to IEC 61508
- PL e corresponding to IEC 13849-1
- Category 4 according to EN 954

Note

Have the fail-safe part of the system checked and accepted by a registered company in regards to the prescribed technical safety controls before commissioning the HMI device.

Sensor Requirements for Fail-Safe Sensors

NOTICE
Qualified sensor If you do not use any qualified, normed sensors, the safety categories SIL3, PL e and category 4 will not be reached. Only use qualified sensors corresponding with IEC 60947.

Note

Our electronics are equipped with such safety engineering features so that 98% of the maximum permissible probability of hazardous faults is due to all other components of the safety function. This corresponds to the recommended load division in safety engineering between sensing devices, actuating devices, and electronic switching for input, processing, and output.

The probability of hazardous faults and the rate of occurrence of hazardous faults of a safety function must comply with an upper limit determined by an SIL or PL. For a description of the HMI device, refer to section "Technical specifications (Page 107)".

If you operate the HMI device with an EMERGENCY-STOP button, you must use a 2-channel equivalent sensor switching - see section "General (Page 55)".

Proof-test interval

Note the following:

- They have a considerable safety responsibility for the instrumentation with sensors.
- Sensors normally do not survive a proof-test interval of 10 years corresponding with IEC 61508.

The sensors clearly lose their safety.

Note

In order to reach the safety categories SIL3, PL e and category 4, high-quality sensors are required. The sensors used must fulfill the standards IEC EN 60947-5-1:2004 and IEC EN 60947-5-5:1997 (VDE 0660, section 200).

The contacts of the sensors must be weld-resistant in accordance with the standard IEC EN 60947-5. Ensure the short-circuit-free connection of the emergency-stop button.

Define an ideal proof-test interval for the used sensor.

Fault detection

Faults can be detected if the following connection errors are present:

- When non-equivalent sensor signals are connected.
- When a single-channel sensor has a redundant connection.

 WARNING
No redundant connection of two single-channel break contacts
If sensor signals are connected redundantly (break contacts), a fault will only be recognized if one of the sensors is triggered.
Ascertain that under no circumstances are two single-channel break contacts redundantly connected as sensor signals.

Signal duration

In order to assure accurate detection of the sensor signal by the HMI device, you must ensure that the minimum duration for the sensor signal is adhered to. See section "Technical specifications (Page 107)". The minimum duration is ensured by the usage of push-to-lock emergency stop buttons.

3.7.3 Cables

The cables used must meet the following requirements:

- The unique assignment of terminals to sensors must be ensured.
- Cables laid outside of the switching cabinet must be laid separately in accordance with the relevant standards.

Use stable pipes or cable channels in order to avoid short circuits and cross-circuits.

Note

With the connection of an emergency stop button to the fail-safe channels of the HMI device, the line lengths corresponding with chapter "Technical specifications (Page 107)" must be complied with.

Mounting and connecting the HMI device

4.1 "Mounting and connection of HMI device" checklist

The following steps must be taken when mounting and connecting the HMI device.

Test step	Check
Check the scope of delivery (Page 47)	
Mounting the HMI device (Page 47)	
Connecting the power supply (Page 52)	
Connect standard inputs/outputs (Page 54)	
General (Page 55)	
Connecting the EMERGENCY STOP button (Page 58)	
Connecting the PLC (Page 61)	
Switching on and testing the HMI device (Page 63)	

4.2 Check the scope of delivery

Check the scope of delivery for completeness and visible signs of transport damage.

NOTICE
<p>Do not use damaged parts</p> <p>If you use defective parts from the items delivered, you may experience malfunctions.</p> <p>If you find defective parts in the item delivered, contact your Siemens partner. Only install undamaged parts.</p>

4.3 Mounting the HMI device

Requirement

- For KP8, KP8F: Four mounting clamps.
For KP32F: Ten mounting clamps.
The mounting clamps are included in the accessory kit.
- The HMI device comes equipped with a mounting seal.
If the mounting seal is damaged, do not mount the HMI device.

Procedure

Note

Always mount the HMI device according to the operating instructions in this manual.

When mounting the HMI device, ensure that the labeling strips do not become jammed between the mounting cut-out and the HMI device.

1. Insert the HMI device into the mounting cut-out.
2. Insert a mounting clamp into a recess of the HMI device.
3. Fasten each mounting clamp by tightening its screws.
The permitted torque is 0.2 Nm.
4. Repeat step 2 and 3 for all mounting clamps until all required clamps are tightened.

4.4 Connecting the HMI device

4.4.1 Connection sequences and lines

Requirement

- The HMI device must be mounted according to the specifications of these operating instructions.
- Shielded standard cables

For additional information, refer to the Internet at:

Industry Mall (<http://mall.automation.siemens.com>)

Connection sequence

Note

Failure to do so may result in damage to the HMI device.

Connect the HMI device in the following sequence:

1. With KP32F functional grounding
2. Power supply
3. Controller

Proceed in a reverse direction when disconnecting the connections.

Connecting the cables

Pay attention to the following when connecting the lines:

- Do not bend contact pins
- All plug connectors are coded against polarity reversal.

The setting of the interfaces is described in section "Technical specifications (Page 105)".

4.4.2 Ports

Note

The PROFINET interfaces are released for operation in a LAN. The PROFINET interfaces are not suitable for telecommunication interfaces.

The following figure shows the interfaces of the KP8.

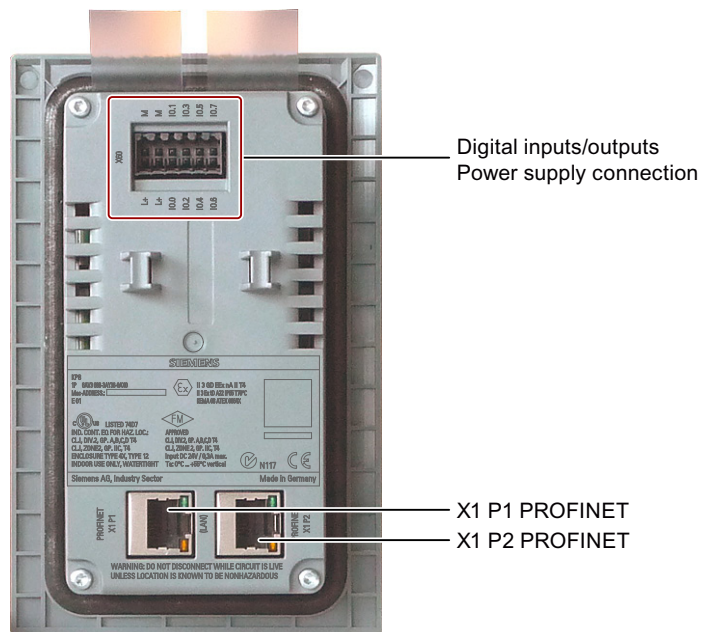

In contrast to the KP8, the KP8F has a 16-pin connector for the digital inputs/outputs and for connection of the power supply. For a description of the interfaces, refer to section "Interface description (Page 112)".

The following figure shows the interfaces of the KP32F.

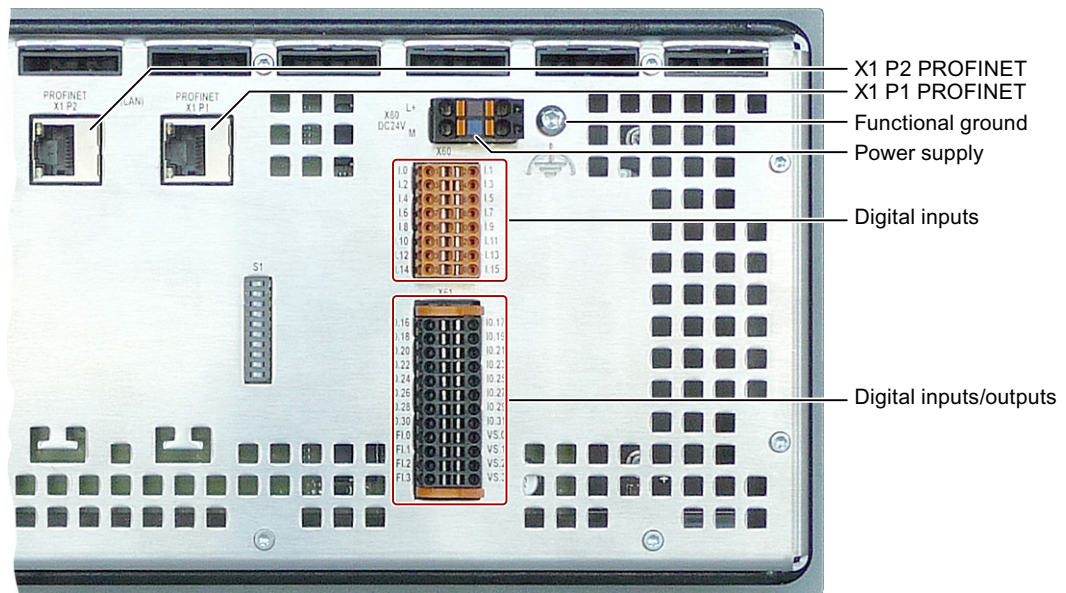

4.4.3 Connecting functional grounding at the KP32F

Differences in electrical potential

Differences in potential may occur between spatially separated system parts. Such differences in electrical potential can lead to high equalizing currents over the data cables and therefore to the destruction of their interfaces. Equalizing currents can develop if the cable shielding is terminated at both ends and grounded to different parts of the system.

Differences in potential can develop when a system is connected to different mains.

General requirements of equipotential bonding

Differences in electrical potential must be reduced using equipotential bonding to ensure trouble-free operation of the relevant components of the electronic system. The following must therefore be observed when installing the equipotential bonding circuit:

- The effectiveness of equipotential bonding increases as the impedance of the equipotential bonding conductor decreases or as its cross-section increases.
- If two plant parts are interconnected by means of shielded data cables and their shielding is bonded at both ends to the grounding/protective conductor, the impedance of the additionally installed equipotential bonding cable must not exceed 10% of the shielding impedance.
- The cross-section of a selected equipotential bonding conductor must be capable of handling the maximum equalizing current.

- Use equipotential bonding conductors made of copper or galvanized steel. Establish a large surface contact between the equipotential bonding conductors and the grounding/protective conductor and protect them from corrosion.
- Use a suitable cable clip to clamp the shield of the data cable flush to the equipotential bonding rail. Keep the length of cable between the HMI device and the equipotential bonding rail as short as possible.
- Route the equipotential bonding conductor and data cables in parallel and with minimum clearance between them.

Procedure

1. Connect the functional grounding of the control cabinet according to the following figure.
Cable shielding is not suitable for functional grounding.

Note

Interface blocks may be damaged or destroyed if the cable for the functional ground does not meet the required minimum cross-section according to the following figure.

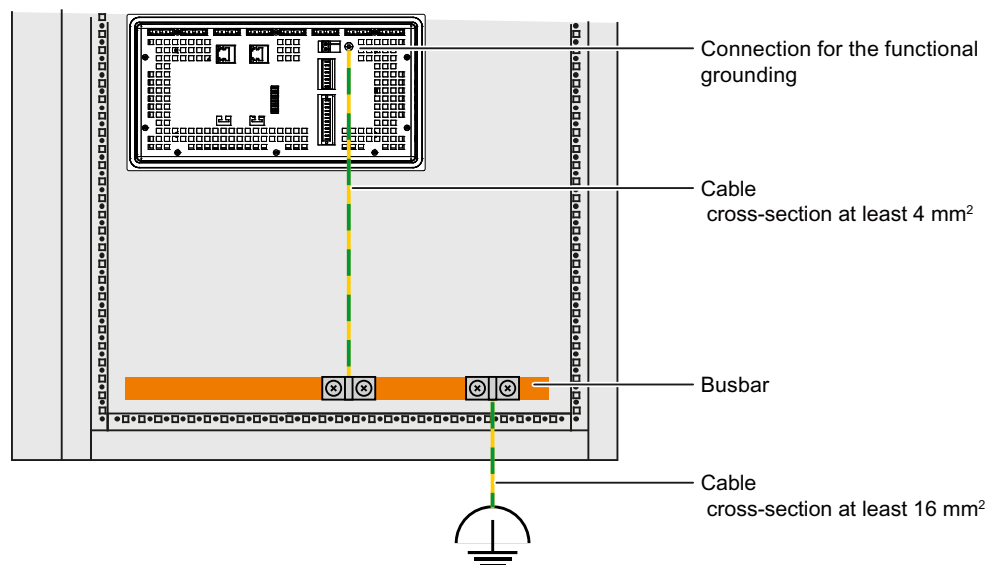

4.4.4 Connecting the power supply

Configuration diagram

The figure below shows the connection between KP8 or KP8F and the power supply.

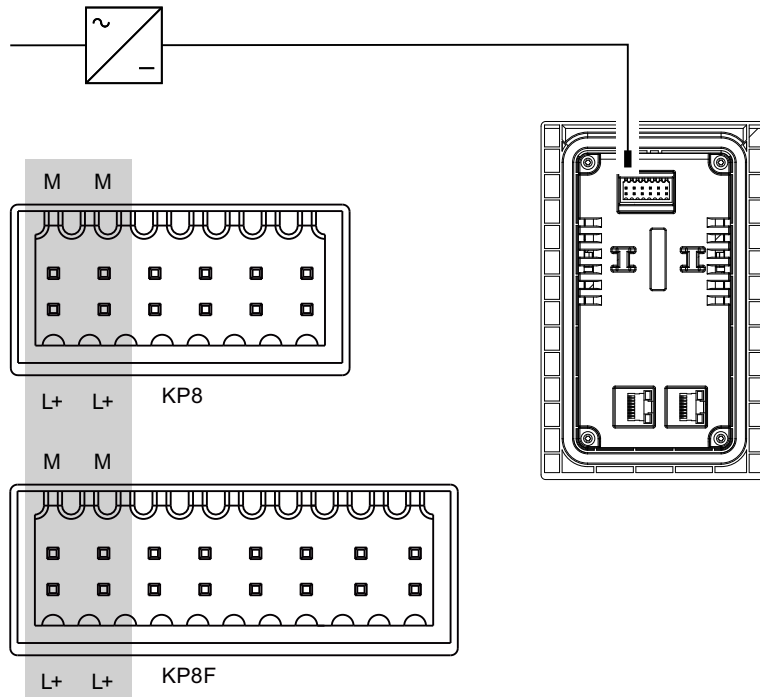

The figure below shows the connection between KP32F and the power supply.

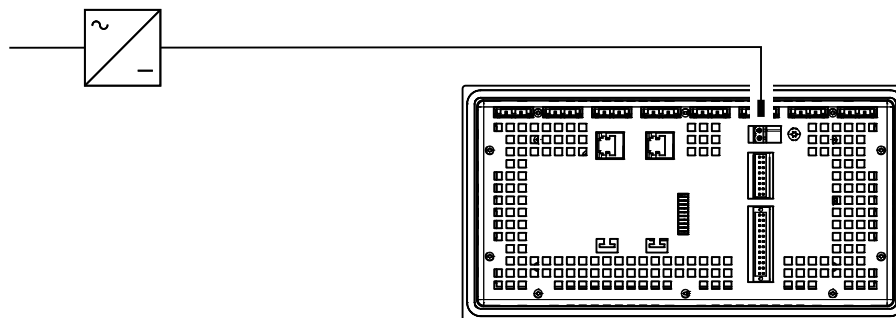

The interfaces are described in the section "Interface description (Page 112)".

Connecting the connector

The plug-in connector for connecting the power supply is contained in the accessory kit and is designed for cables with a maximum cross-section of 1 mm². Note the following diagram when stripping the wire.

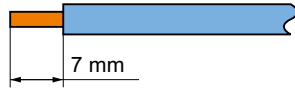

NOTICE

Damage possible

Do not connect the lines if the connector is in the HMI device. You may otherwise damage the mounting of the HMI device socket.

Always remove the connector to connect the wires.

To open the connectors, press in the opening provided with a screwdriver for slotted screws. Slide the cable into the connector enclosure and remove the screwdriver. The wire is fixed.

Do not confuse the wires. Refer to the label for the contact pins on the rear of the HMI device.

Note

The HMI device is equipped with a polarity reversal protection circuit.

Connecting the power supply

⚠ CAUTION

For the 24 VDC supply, use only power supply units with safety isolation complying with IEC 364-4-41 or HD 384.04.41 (VDE 0100, Part 410), for example according to the standards, SELV (Safety Extra Low Voltage) and PELV (Protective Extra Low Voltage).

The supply voltage must be within the specified voltage range. Any other voltage might lead to failure of the HMI device.

Applies to floating system design:

Connect the connection for GND 24 V from the 24 V power supply output to equipotential bonding for uniform reference potential. For this purpose, choose a connecting point that is as close as possible to the center.

4.4.5 Connect standard inputs/outputs

On the back of the HMI device are the digital inputs/outputs for **non** fail-safe input and output devices. Non fail-safe inputs/outputs are shown in gray in the following illustrations.

Unconnected inputs/outputs are automatically set to "0".

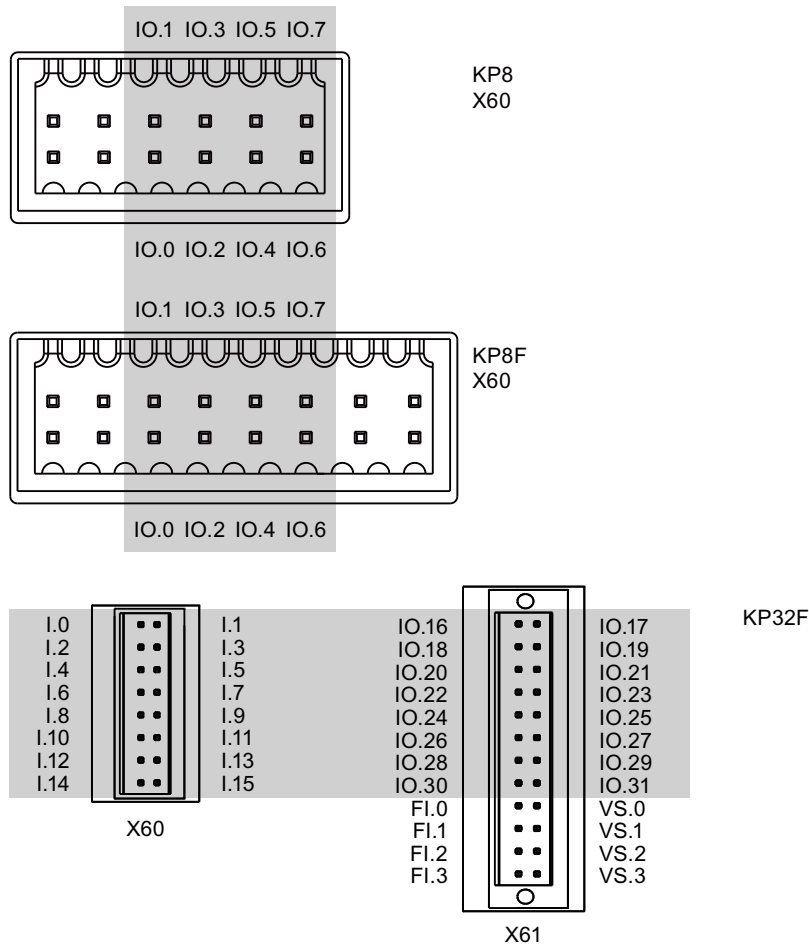

The signal assignment is described in the section "Interface description (Page 112)".

Procedure

Note

Follow the notes about connectors in section "Connecting the power supply (Page 52)".

1. Connect the wires on the connector corresponding with the setting of the socket on the rear of the HMI device.

4.4.6 Connecting KP8F - fail-safe inputs

4.4.6.1 General

The KP8F is intended for operation of an emergency stop button and fail-safe sensor. Please observe the information in Section "Sensor for 1oo1 mode (Page 42)" and "Sensor for 1oo2 mode (Page 43)".

Note

For supplying the fail-safe inputs, only inputs labeled with VS may be used on the HMI device.

Only connect fail-safe inputs if these are also used. This also applies for disabled fail-safe inputs.

Follow the notes about connectors in section "Connecting the power supply (Page 52)".

4.4.6.2 Connecting the EMERGENCY STOP button

Requirement

- 1 connector, see accessory kit
- 1 EMERGENCY STOP button

Note

If, in STEP 7 HW Config, you selected the option "No evaluation" for the KP8F in the "Evaluation of the sensor" parameter and no sensor is connected, the value 0 will be reported to the controller for the sensor values in the process illustration.

See section and "KP8 and KP8F - Bit assignment in the process image (Page 116)".

Procedure

1. Connect the EMERGENCY-STOP button as follows to the connector for the fail-safe digital inputs:
 - Sensor supply VS.0 for the FI.0 input
 - Sensor supply VS.1 for the FI.1 input

Note

The assignment of the fail-safe inputs has changed as of product version 03.

External power supply is not permissible for VS.0 and VS.1.

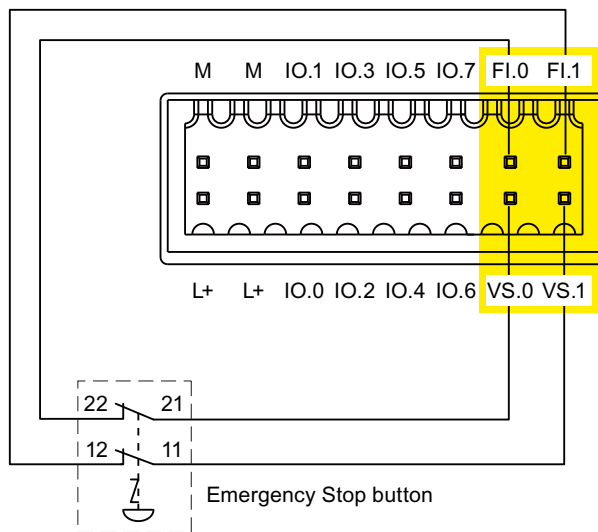

The EMERGENCY-STOP button must be connected as an equivalent break contact. Observe the affiliated setting for "Evaluation of the sensor" in the HW config - see section "KP8F – Setting the fail-safe properties (Page 77)".

4.4.6.3 Fail-safe connection of sensor

Requirement

- 1 connector, see accessory kit
- 2 buttons as NC contact or NO contact

Procedure

The following approach is an example.

1. Connect the button as follows to the connector for the fail-safe digital inputs:
 - Sensor supply VS.0 for the FI.0 input
 - Sensor supply VS.1 for the FI.1 input

Note

The assignment of the fail-safe inputs has changed as of product version 03.

External power supply is not permissible for VS.0 and VS.1.

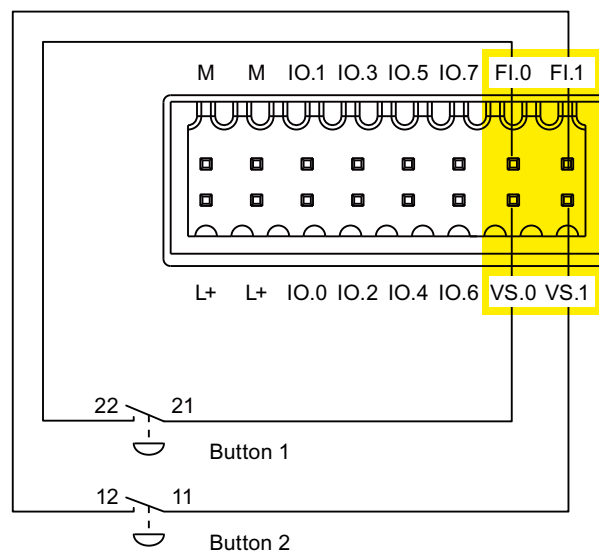

Observe the respective setting for "Evaluation of the sensor" in HW Config - see section "Setting the fail-safe properties (Page 89)".

4.4.7 Connecting KP32F - fail-safe inputs

4.4.7.1 General

The KP32F is intended for the connection of EMERGENCY STOP buttons and fail-safe sensors. Please observe the information in Section "Sensor for 1oo1 mode (Page 42)" and "Sensor for 1oo2 mode (Page 43)".

Note

For supplying the fail-safe inputs, only inputs labeled with VS may be used on the HMI device.

Only connect fail-safe inputs if these are also used. This also applies for disabled fail-safe inputs.

Follow the notes about connectors in section "Connecting the power supply (Page 52)".

4.4.7.2 Connecting the EMERGENCY STOP button

Requirement

- 1 connector, see accessory kit
- 1 or 2 EMERGENCY STOP buttons

Note

If you selected the option "No evaluation" for the KP32F in the "Evaluation of the sensor" parameter in STEP 7 HW Config and no sensor is connected, the value 0 will be reported to the controller for the sensor values in the process image.

See section "KP32F - Bit assignment in the process image (Page 119)".

Procedure

1. Connect the EMERGENCY-STOP button as follows to the connector for the fail-safe digital inputs:
 - Sensor supply VS.0 for the FI.0 input
 - Sensor supply VS.1 for the FI.1 input
 - Sensor supply VS.2 for the FI.2 input
 - Sensor supply VS.3 for the FI.3 input

Note

External supply is not permitted for VS.0, VS.1, VS.2 and VS.3.

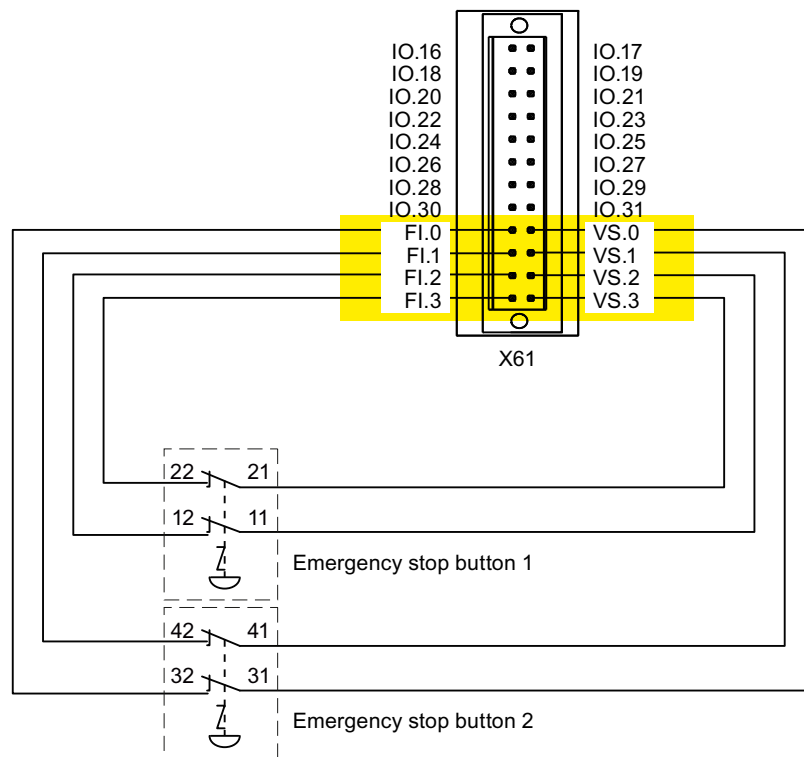

The following connection options are available:

FI.0	FI.1	FI.2	FI.3
1oo1	1oo1	Not connected	
1oo2		Not connected	
1oo2		1oo2	
1oo2		1oo1	1oo1
1oo1	1oo1	1oo1	1oo1

The EMERGENCY-STOP button must be connected as an equivalent break contact. Observe the respective setting for "Evaluation of the sensor" in HW Config - see section "Setting the fail-safe properties (Page 89)".

4.4.7.3 Fail-safe connection of sensor

Requirement

- 1 connector, see accessory kit
- 2 to 4 buttons as NC contact or NO contact

Procedure

The following approach is an example.

1. Connect the button as follows to the connector for the fail-safe digital inputs:
 - Sensor supply VS.0 for the FI.0 input
 - Sensor supply VS.1 for the FI.1 input
 - Sensor supply VS.2 for the FI.2 input
 - Sensor supply VS.3 for the FI.3 input

Note

External supply is not permitted for VS.0, VS.1, VS.2 and VS.3.

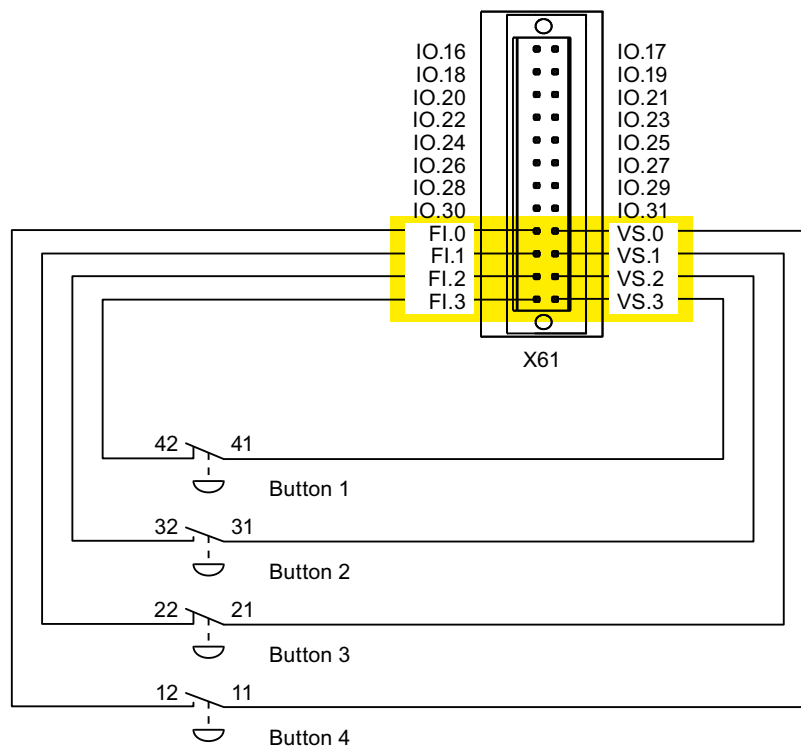

The following connection options are available:

FI.0	FI.1	FI.2	FI.3
1oo1	1oo1	Not connected	
1oo2		Not connected	
1oo2		1oo2	
1oo2		1oo1	1oo1
1oo1	1oo1	1oo1	1oo1

Observe the respective setting for "Evaluation of the sensor" in HW Config - see section "Setting the fail-safe properties (Page 89)".

4.4.8 Connecting the PLC

The connection between the HMI device and controller depends on the topology of the PROFINET network.

- Line
All the communication nodes are connected in series as a bus. The series structure is implemented with switches that are integrated in the PROFINET devices.
- Star
The communication nodes are connected with a switch, from the Scalance X208 or X204 series for example.

You can find additional information on the topology of PROFINET networks in the system manual, "PROFINET System Description".

Note

Always use only the approved cables to connect a SIMATIC S7 controller.

Standard cables are available for the connection. You will find more information in the SIMATIC NET-catalog IK PI or on the Internet at:

Industry Mall (<http://mall.automation.siemens.com>)

Configuration diagram for serial configuration

The figure below illustrates the connection between the HMI device and the controller with a serial configuration.

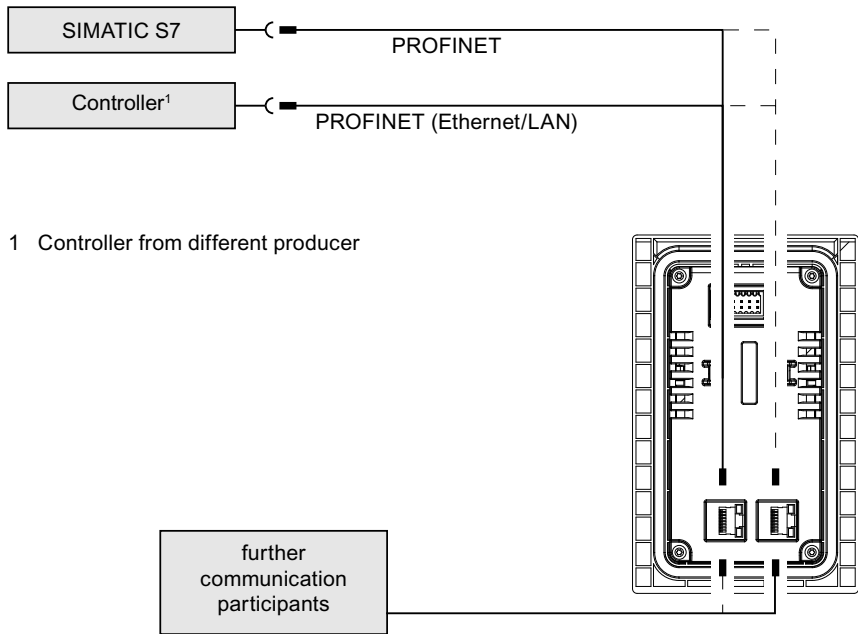

Configuration diagram for star configuration

The following figure shows the connection between the HMI device and the controller with a star configuration.

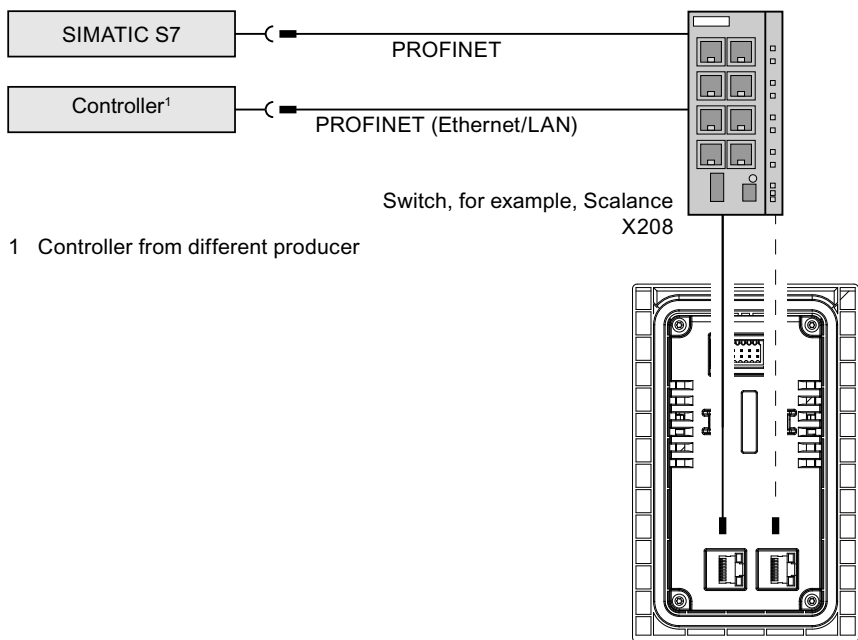

4.5 Switching on and testing the HMI device

Note

If the KP8F or KP32F is operated with fail-safe components, check before each commissioning, whether the required sensor evaluation is set correctly according to the circuit. See section "KP8F – Setting the fail-safe properties (Page 77)" and "Setting the fail-safe properties (Page 89)".

Procedure

1. Switch on the power supply.

After starting the HMI device, all LEDs will illuminate corresponding to the setting. The default illumination time is 5 s.

Note

As long as the light test is executed, no keyboard entry will be transferred to the connected controller.

If the HMI device does not start, it is possible the wires on the connector have been crossed. Check the connected wires and change the connections if necessary.

2. Press each light button after one another.

The LED of the illuminated pushbutton goes off while it is pressed.

3. Applies to KP8F and KP32F:

If fail-safe components are connected, you must conduct a function test of the fail-safe components each time you turn them on.

Switching off the HMI device

NOTICE
Switching off the device
The plant can enter the fail-safe state when you switch off a PROFIsafe device, depending on the configuration.
Before you switch off the device, check its integration into the control program.

If you want to switch off the HMI device, interrupt the power supply. The HMI device is not equipped with an off switch.

4.6 Securing the cables

After the power-on test, use cable ties to secure the connected cables to the marked fixing elements to ensure strain relief.

- Strain relief on the KP8 and KP8F

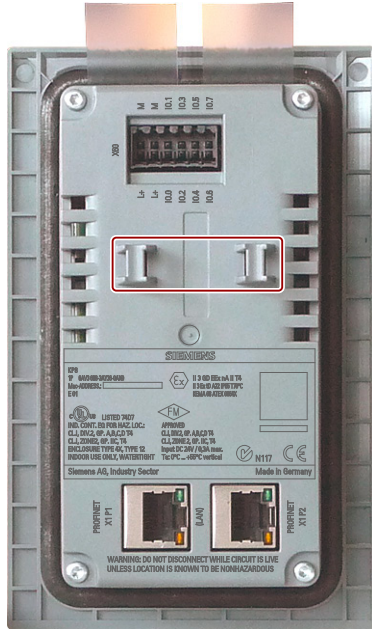

- Strain relief on the KP32F

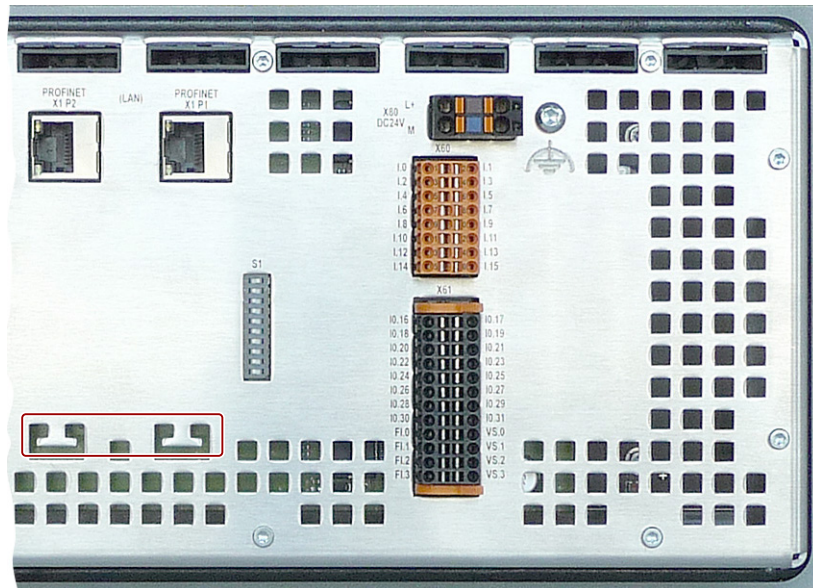

Operator controls and displays

5.1 Front-sided control elements and displays

Operator control elements

There are illuminated pushbuttons on the front of the HMI device. The following figures show the illuminated pushbuttons and the numbering of the associated LEDs.

- KP8 and KP8F



- KP32F

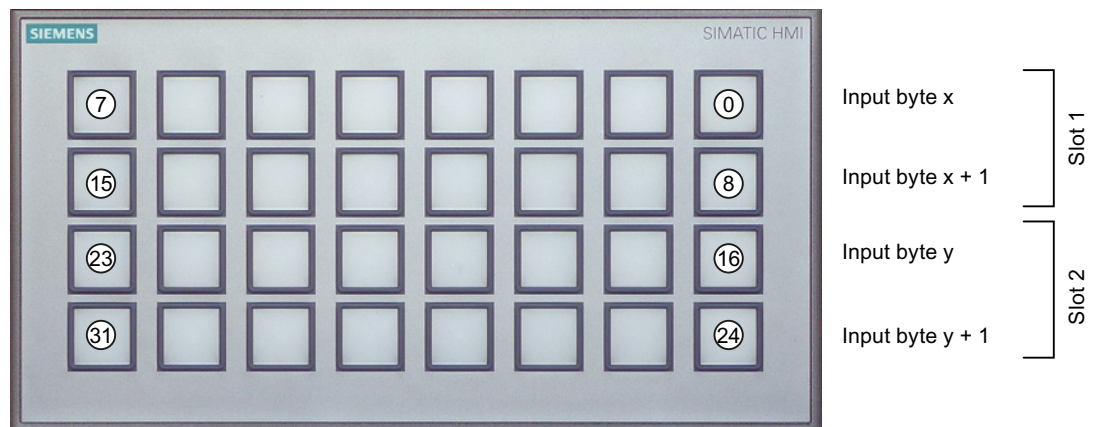

- x Input byte start address of slot 1
- y Input byte start address of slot 2

The following control elements and displays are located on the rear of the KP32F.

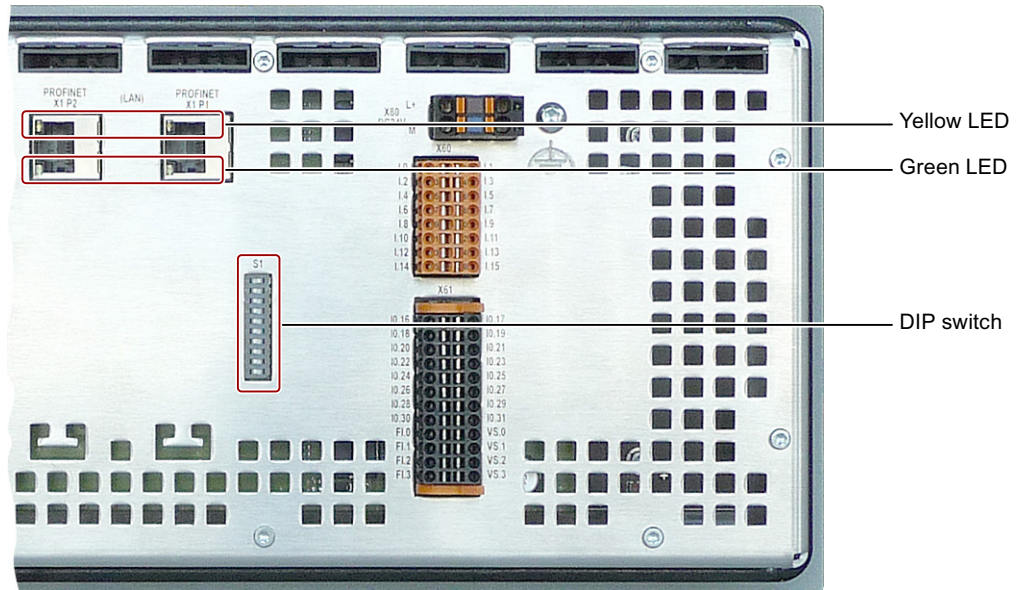

PROFINET interfaces

There are two LEDs on each PROFINET interface. These LEDs display the status of the PROFINET communication. The following table shows the meaning:

Green LED LINK	Yellow LED RX/TX	Meaning
OFF	OFF	No PROFINET connection
On	OFF	PROFINET communication possible
On	On	PROFINET communication runs

5.3 Labeling keys

You can label the keys as required for your project. Use the labeling strip for this purpose.

- KP8 and KP8F

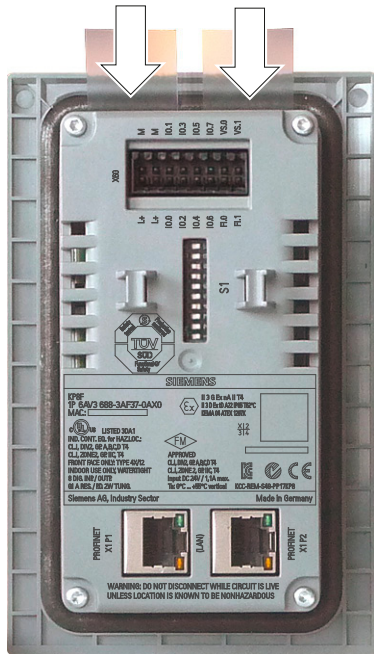

When installed, the labeling strips can be inserted if the mounting has a material thickness of < 3.5 mm. With larger material thicknesses, the disassembly of the HMI device is required if a labeling strip should be changed.

- KP32F

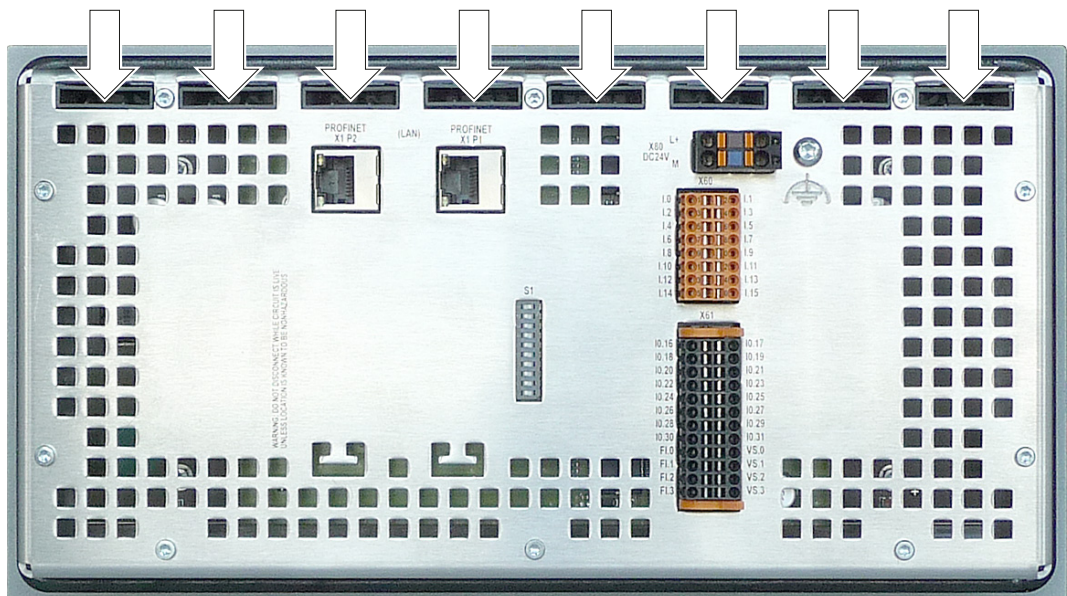

With KP32F you can replace the labeling strips in the installed state without restrictions.

Note

Do not write on the keyboard to label the function keys.

Printing labeling strips

A template for the labeling strips is available as a Word file online under:

"Labeling strips for SIMATIC Panels

(<http://support.automation.siemens.com/WW/view/en/11274631>)"

Observe the information in this file.

The labeling strip of the KP8 and the KP8F have the following dimensions:

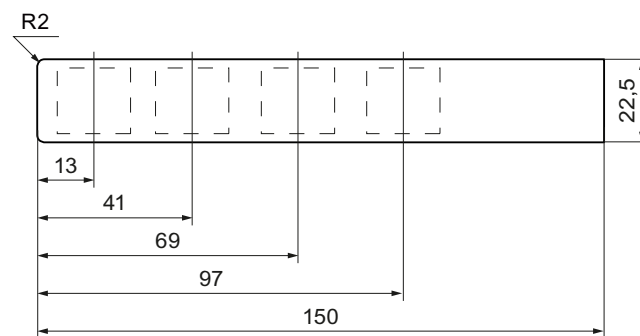

Visible window area, 20 x 20

All dimensions in mm.

The labeling strip of the KP32F has the following dimensions:

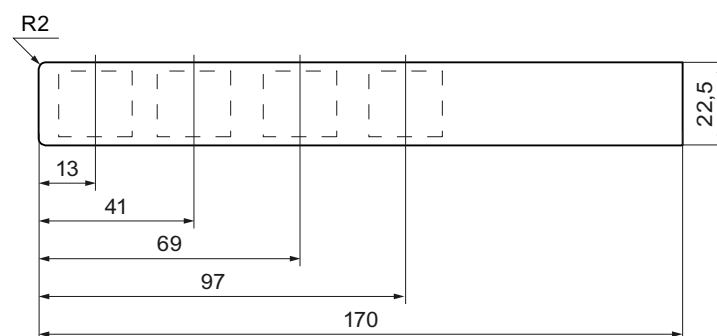

Visible window area, 20 x 20

All dimensions in mm.

Procedure

1. Edit the template.
2. Print the template.

You can use printable foils. Always ensure an adequate material stiffness during the selection. This is needed to insert the labeling strips. The maximum permitted thickness of the labeling strip is 0.15 mm.

Alternatively, you can also label the strips by hand.

Note

Wait for the printed labeling strips to dry before you insert them.

3. Cut out the labeling strip.

Ensure that the corners are cut according to the corresponding diagram, as this makes it easier to slide them into the slot.

4. Remove any previously existing labeling strips.
5. Slide the new labeling strips into the guide up to the stop.

The labeling strip will protrude approximately 1 cm out of the guide. The template dimensions for the labeling strips are designed so that the labeling is correctly placed for the keys. An interlock is not required for the labeling strips.

Assigning parameters for the HMI device in STEP 7

6.1 Checklist "Assign parameters for the HMI device"

Parameter assignment in STEP 7 and on the HMI device are required for operation of the HMI device. Information on how to assign parameters of the fail-safe I/O in STEP 7, is available in the Programming and operation manual "S7 Distributed Safety - Configuring and Programming" (<http://support.automation.siemens.com/WW/view/en/22099875>) and in the "Safety Technology in SIMATIC S7" system manual (<http://support.automation.siemens.com/WW/view/en/12490443>).

- Parameter assignment checklist for KP8 and KP8F

Test step	Information	Check
Assign parameters for slot 0	Assigning parameters for the KP8 and KP8F (Page 74)	
Assign parameters for slot 1	Setting the properties of the digital inputs/outputs (Page 76)	
Assign parameters for slot 2 of the KP8F	KP8F – Setting the fail-safe properties (Page 77)	

- Parameter assignment checklist for KP32F

Test step	Information	Check
Setting PROFINET	Setting the properties for PROFINET (Page 85)	
Setting the addresses of the inputs/outputs and the properties of the light test	Setting the properties and addresses of the lights and buttons (Page 85)	
Setting the properties of the digital inputs	Setting the properties of the digital inputs (Page 87)	
Setting the properties of the digital inputs/outputs	Setting the properties of the digital inputs/outputs (Page 88)	
Setting the fail-safe properties	Setting the fail-safe properties (Page 89)	

6.2 Integrating GSDML in STEP 7

If the HMI device is not listed in the hardware catalog of HW Config, you need to integrate a valid GSD (device database) file for the HMI device in the STEP 7 database.

Requirement

- The GSD is installed.
Information on installing the GSD can be found online at:
Integrating a GSD File (<http://support.automation.siemens.com/WW/view/en/22817133>)
- STEP 7 applications, e.g., the LAD/STL/FBD editor or the symbol table, are closed.
- SIMATIC Manager is open.

Displaying the HMI device

- Catalog structure with KP8 and KP8F

KP8 and KP8F are displayed in the catalog structure of the HW Config, "GSD" folder - see red labeling in the following image.

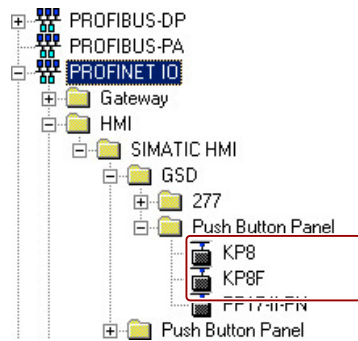

- Catalog structure with KP32F

KP32F devices are displayed in the catalog structure of the HW Config, "GSD" folder - see red identification in the following figure.

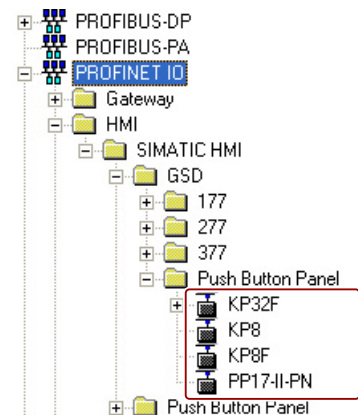

Parameterizable slots

The STEP 7 project has to be configured and parameters assigned in HW Config to enable communication between HMI device and controller.

Note

The KP8F can only be configured with a – non fail-safe – standard controller if this standard controller supports Shared Device.

Assign parameters for the following slots:

- KP8 and KP8F
 - Slot 0
 - Slot 1
 - Slot 2 - for KP8F
 - Parameters for fail-safe operation are assigned via slot 2.
- KP32F
 - Slot 0
 - Slot 1 and 4
 - Slot 5
 - Parameters for fail-safe operation are assigned via slot 5.

6.3 KP8 and KP8F

6.3.1 Assigning parameters for the KP8 and KP8F

The SIMATIC Manager and HW Config are opened. A project was created with a KP8F. In the following image, the slots that require parameter assignment are labeled in red.

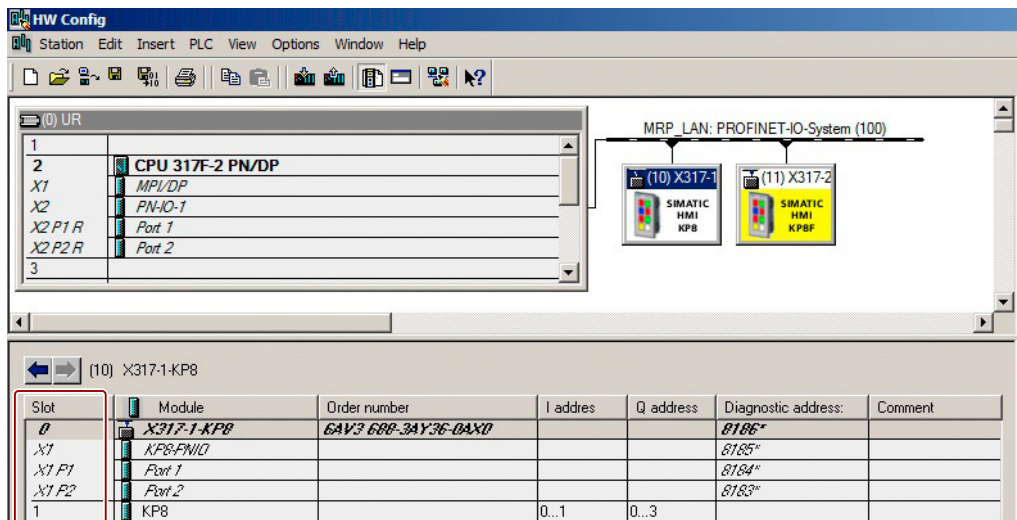

The setting described in the following uses KP8 as an example and applies similarly for the KP8F.

Parameters for following slots are entered in HW Config:

- Slot 0 – device identification
 You can find additional information on device name and device number in the manual "SIMATIC PROFINET system description (<http://support.automation.siemens.com/WW/view/en/19292127>)".
- Slot 1 - address area of the keys and LEDs 0 to 8 and lamp test on this slot

6.3.2 Setting the properties for PROFINET

Requirement

- A project is open in "HW Config".

The setting described in the following uses KP8 as an example and applies similarly for the KP8F.

Procedure

1. Double click in the station window on the module.
The "Properties – [Name]" dialog box opens.
2. Select the "General" tab.

Parameter	Meaning
Device name	The IO controller addresses the IO device using its device name. The device name must be unique within the computer network. The device name is connected with the IP-address, which is set for the HMI device.
Device number	You can identify an IO device in the user program with its device number. STEP 7 assigns the device number.

3. Change the entries, if required.
The changes are displayed in the detail view.
4. If you want to change the current IP address, click the "Ethernet" button.
A dialog window is displayed.
5. Change the entries, if required.
6. Click "OK".
The entries are saved. The dialog box closes.

6.3.3 Setting the properties of the digital inputs/outputs

Requirement

- A project is open in "HW Config".

Procedure

1. Double click in the properties window on slot 1.
The "Properties – KP8 inputs/outputs" dialog box opens.
2. Open the "Addresses" tab.

In the "Inputs" and "Outputs" groups, the start values of the address areas are set depending on the controller used.

Parameter	Meaning
Inputs > Start	Start of address range in which the PROFIsafe inputs/outputs for the fail-safe HMI device are mapped.
Inputs > Process Image	Process image to which the address range belongs. This parameter cannot be set with controllers of the SIMATIC CPU 300 type.
Outputs > Start	Start of address range in which the PROFIsafe inputs/outputs for the fail-safe HMI device are mapped.
Outputs > Process Image	Process image to which the address range belongs. This parameter cannot be set with controllers of the SIMATIC CPU 300 type.

3. Change the entries, if required.
4. Select the "Parameters" tab.
5. Open the "Parameters > Device-specific parameters" folder.

Parameter	Meaning
Duration of the light test	The value range from 0 to 60 s can be set. With the value "0", no light test is executed. Default setting is 5 s.
Brightness	Adjustable: very bright, bright, normal, dark or very dark Default setting is "normal".
Function of the clamp 0	Adjustable: Input or output, default setting is input
Function of the clamp 1	Adjustable: Input or output, default setting is input
...	...
Function of the clamp 6	Adjustable: Input or output, default setting is output
Function of the clamp 7	Adjustable: Input or output, default setting is output

6. Change the entries, if required.

7. Click "OK".

The entries are saved. The dialog box closes.

Result

The HMI device will now respond in operation according to the new setting. The switch states of the digital inputs/outputs of the HMI device are stored in the specified address area of the controller.

6.3.4 KP8F – Setting the fail-safe properties

This step applies to the fail-safe slot 2 of KP8F.

Requirement

- The password for the security program must be known.
- The SIMATIC Manager and HW Config are opened.
- A project was created with a KP8F.

In the following image, the slot that requires parameter assignment is labeled in red.

Slot	Module	Order number	I address	Q address	Diagnostic address:	Comment
0	X317-1-KP8	6AV3 6BB-3AY36-0AX0			8186*	
X1	KP8-PNIO				8185*	
X1 P1	Port 1				8184*	
X1 P2	Port 2				8183*	
1	KP8		0...1	0...3		
2	F-DI					

Procedure

1. Double click in the properties window on slot 2.

The "Properties – F-DI" dialog box opens.

2. Open the "Addresses" tab.

In the "Inputs" and "Outputs" groups, the start values of the address areas are set depending on the controller used. The signals of the F channels of the HMI device are mapped in these address ranges.

Parameter	Meaning
Inputs > Start	Start of address range in which the safety-relevant usage data of the HMI device are mapped.
Inputs > Process Image	Process image to which the address range belongs. This parameter cannot be entered with a controller of the SIMATIC CPU 300 type.
Outputs > Start	Start of address range in which the safety-relevant usage data of the HMI device are mapped.
Outputs > Process Image	Process image to which the address range belongs. This parameter cannot be entered with a controller of the SIMATIC CPU 300 type.

3. Check the default entry of the addresses for "Start".

If necessary, change the address range.

4. Select the "Parameters" tab.

5. Open the "Parameters > Device-specific Panels > Evaluation of the sensors" directory.

6. In the list, select:

- Not activated

"Not activated" is the default entry.

- 1oo2 (2v2)-evaluation, EMERGENCY STOP

- 1oo1 (1v1)-evaluation, single-channel

The selection is based on the connection corresponding with section "General (Page 55)".

Note

Make sure that the sensor is monitored corresponding with its connection.

7. Click "OK".

The entries are saved. The dialog box closes.

8. Open the "PROFIsafe" tab.

If no access rights exist, the following dialog box will be shown.

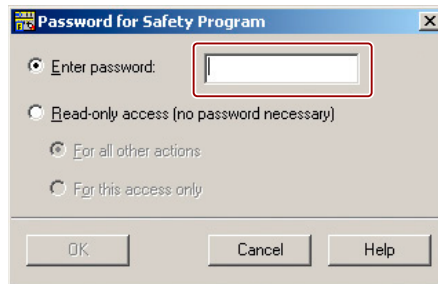

9. Enter the password that was assigned when the safety program was created in Distributed Safety.

10. Click "OK".

The dialog box closes.

11. If necessary, change the "F_Dest_Add" parameter.

To do this, use the "Change value" button. Assign a network and station-wide unique address.

12. Change the monitoring time "F_WD_Time" if needed.

13. Click "OK".

The entries are saved. The dialog box closes.

Result

The HMI device will now respond in operation according to the new setting. The switch states of the digital inputs of the HMI device are stored in the specified address area of the controller.

See also

Connecting the EMERGENCY STOP button (Page 58)

6.3.5 KP8F – Configure Shared Device

KP8F is designed for shared device.

Shared Device is the parallel and independent access from two different controllers to the same HMI device. A fixed assignment of the different modules that are used in an automation device must be configured to a select controller. The unique assignment of the module to the controller is always guaranteed and visible for the user.

Requirement

- A project is open in "HW Config".

In the following image, the module to be configured is labeled in red.

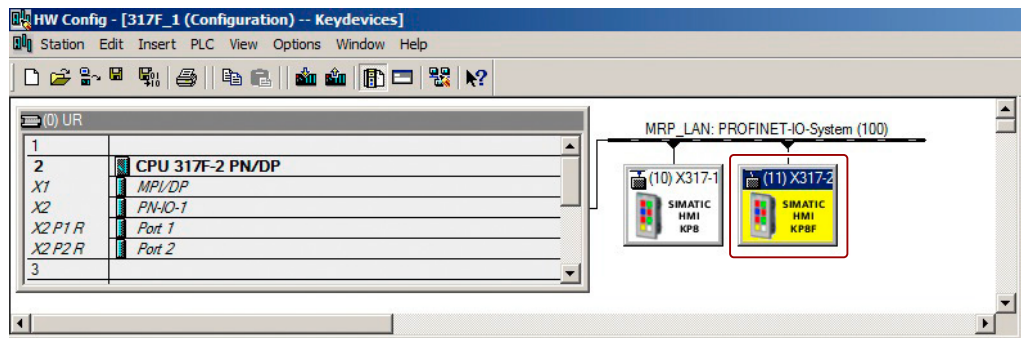

Procedure

1. Double-click in the station window on the marked device.

The following dialog appears.

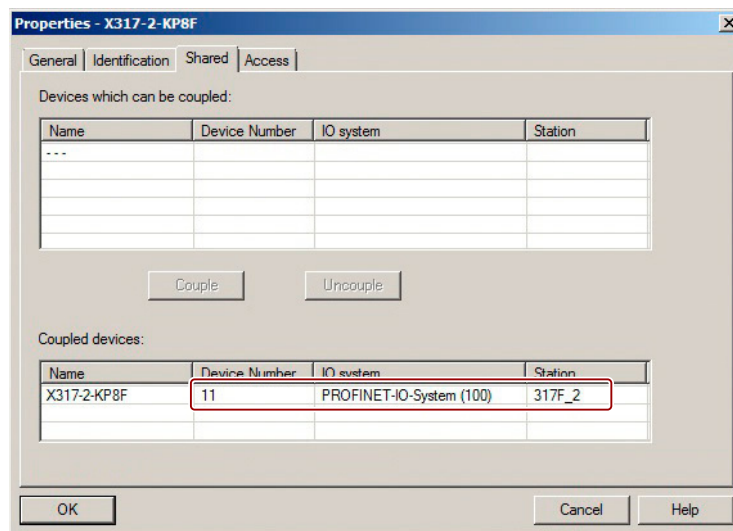

2. Select the "Shared" tab.
The buttons are gray as long as no device is selected.
3. In the "Shared Device" group, select the device to be coupled to the KP8F.

4. Press "Connect".

The Shared Device connection is established. The coupled device is displayed in the "Shared Device" group. See red marking.

5. If you want to decouple a Shared Device connection, select the device in question.

6. Click the "Disconnect" button.

The Shared Device connection is terminated. The decoupled device is displayed in the "Shared Device" group.

7. If there are several Shared Device connections, you must select a device for full access.

The following dialog appears:

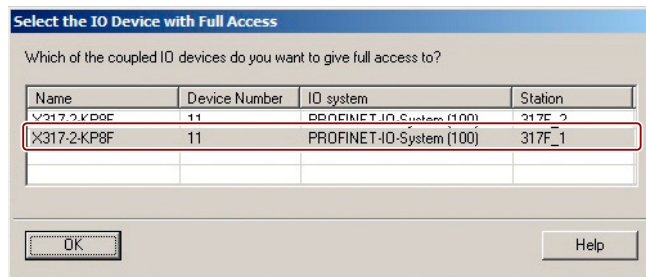

8. Select the required device for the access type "Full".

9. Click "OK".

The entry is saved. The dialog box closes.

10. Select the "Access" tab.

The following dialog appears:

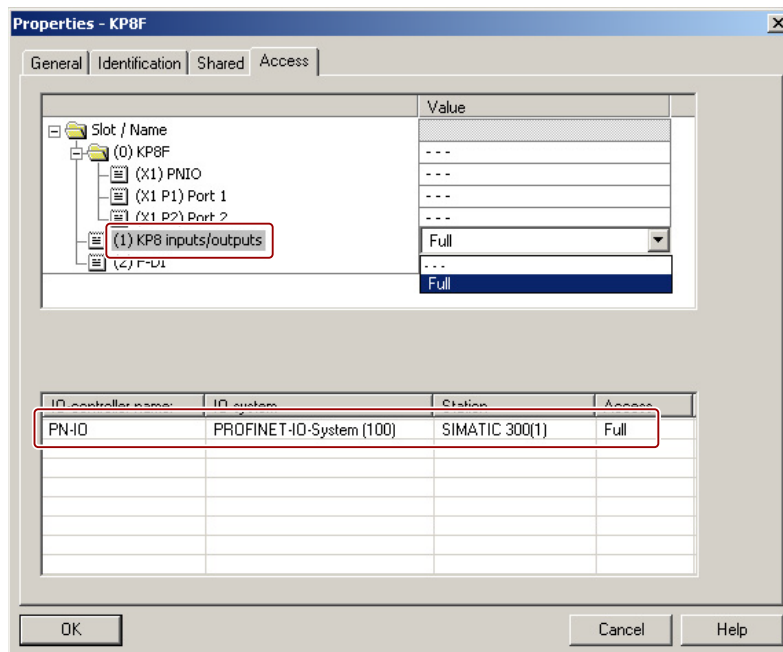

6.3 KP8 and KP8F

11. Select the Shared Device connection for which you want to change the access.

Parameter	Meaning
full	Read and write access by the controller
...	No access by the controller

12. Select the required parameter.

13. Click "OK".

The entry is saved. The dialog box closes.

Result

Shared Device is configured for the KP8F.

6.3.6 KP8F – Configure Shared Device for non fail-safe controller

You can also operate the KP8F with a non fail-safe controller. The non fail-safe controller must support Shared Device in this case.

Requirement

- "HW Config" is open in the SIMATIC Manager.

In the following image, the module to be configured is labeled in red.

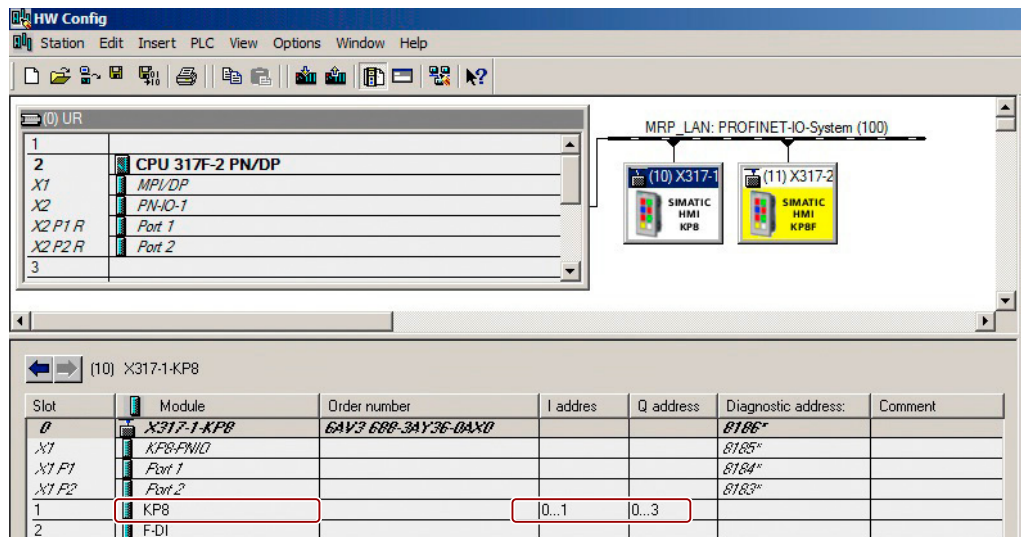

Procedure

1. Perform steps 1 to 9 as described in section "KP8F – Configure Shared Device (Page 80)".
2. Select the "Access" tab.

The following dialog appears:

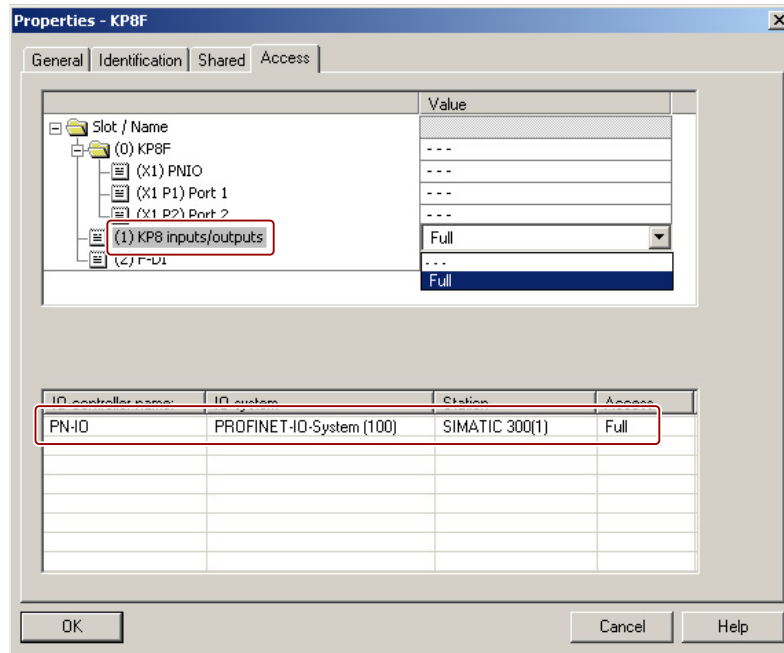

3. Select "...". for the Shared Device connection.
The parameter indicates that there is no access by the controller.
4. Click "OK".
The entry is saved. The dialog box closes.

Result

Shared Device is configured for the KP8F and for a **non** fail-safe controller.

6.4 KP32F

6.4.1 Assign parameters for KP32F

The SIMATIC Manager and HW Config are opened. A project was created with a KP32F. In the following image, the slots that require parameter assignment are labeled in red.

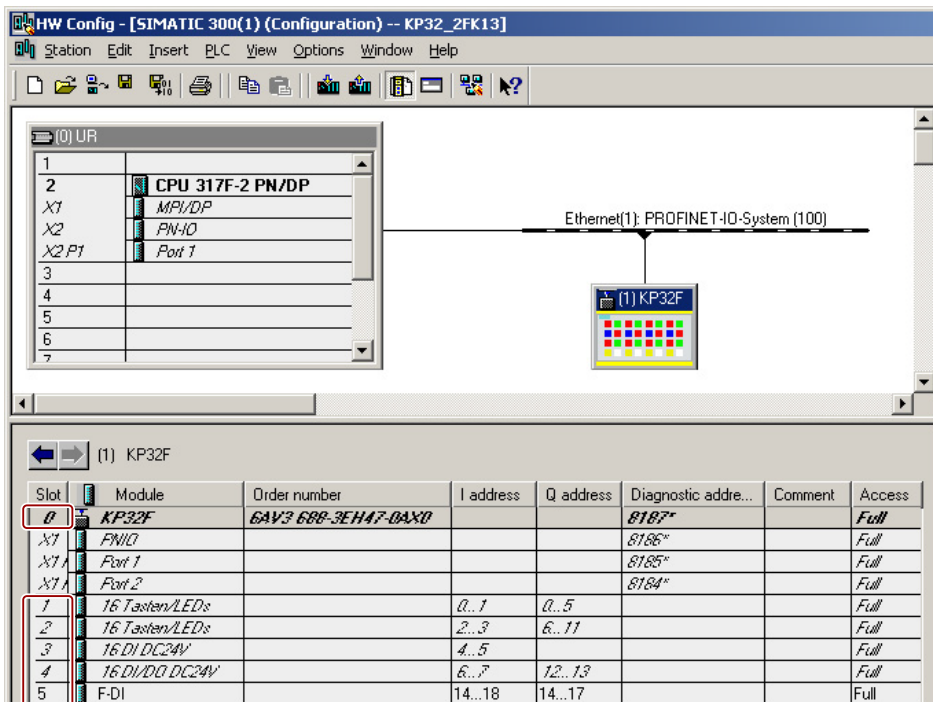

Parameters for following slots are entered in the HW Config for the KP32F:

- Slot 0 – device identification
You can find additional information on device name and device number in the manual "SIMATIC PROFINET system description (<http://support.automation.siemens.com/WW/view/en/19292127>)".
- Slot 1 - address area of the keys and LEDs 0 to 15 and light test on this slot
- Slot 2 - address area of the keys and LEDs 16 to 31
- Slot 3 - digital inputs
- Slot 4 - digital inputs/outputs
- Slot 5 - fail-safe digital inputs

The fail-safe slot is empty by default. Drag-and-drop a fail-safe input to this slot from the hardware catalog.

6.4.2 Setting the properties for PROFINET

Requirement

- A project is open in "HW Config".

Procedure

1. Double click in the station window on the module.
The dialog box "Properties – KP32F" is displayed.
2. Select the "General" tab.

Parameter	Meaning
Device name	The IO controller addresses the IO device using its device name. The device name must be unique within the computer network. The device name is connected with the IP-address, which is set for the HMI device.
Device number	1 to 255 or 256 can be set as device number.
Comment	Field for a comment on the properties of the module

3. Change the entries, if required.
The changes are displayed in the detail view.
4. If you want to change the current IP address, click the "Ethernet" button.
A dialog window is displayed.
5. Change the entries, if required.
6. Click "OK".
The entries are saved. The dialog box closes.

6.4.3 Setting the properties and addresses of the lights and buttons

This step applies to slots 1 and 2; the properties of the light test for all lamps can only be set at slot 1.

Requirement

- A project is open in "HW Config".

Procedure

1. Double-click slot 1 in the detailed view.
The dialog box "Properties – 16 keys/LEDs" is displayed.
2. Select the "General" tab.

Parameter	Meaning
Name	The name is displayed in the detail view, "Module" column
Comment	The name is displayed in the detail view, "Comment" column

3. Change the entries, if required.
4. Open the "Addresses" tab.

In the "Inputs" and "Outputs" groups, the start values of the address areas are set depending on the controller used. The signals of the HMI device are mapped in these address ranges.

Parameter	Meaning
Inputs > Start	Start of the address range in which the user data of the HMI device are mapped.
Inputs > Process Image	Process image to which the address range belongs. This parameter cannot be entered with a controller of the SIMATIC CPU 300 type.
Outputs > Start	Start of the address range in which the user data of the HMI device are mapped.
Outputs > Process Image	Process image to which the address range belongs. This parameter cannot be entered with a controller of the SIMATIC CPU 300 type.

5. Check the standard entry of the addresses.
Change the entries, if required.
6. Select the "Parameters" tab.
7. Open the "Parameters > Device-specific parameters" folder.

Parameter	Meaning
Duration of the light test	The value range from 0 to 60 s can be set. With the value "0", no light test is executed. Default setting is 5 s.
Brightness	Adjustable: very bright, bright, normal, dark or very dark Default setting is "normal".

8. Change the entries, if required.
9. Click "OK".
The entries are saved. The dialog box closes.

Result

The switch states of the digital inputs/outputs of the HMI device are stored in the specified address area of the controller.

6.4.4 Setting the properties of the digital inputs**Requirement**

- A project is open in "HW Config".

Procedure

1. Double-click slot 3 in the detailed view.
The dialog box "Properties – 16 DI DC24V" is displayed.
2. Select the "General" tab.

Parameter	Meaning
Name	The name is displayed in the detail view, "Module" column
Comment	The name is displayed in the detail view, "Comment" column

3. Change the entries, if required.
4. Open the "Addresses" tab.
In the "Inputs" group, the start value of the address range is set depending on the controller used. The signals of the HMI device are mapped in these address ranges.

Parameter	Meaning
Inputs > Start	Start of the address range in which the user data of the HMI device are mapped.
Inputs > Process Image	Process image to which the address range belongs. This parameter cannot be entered with a controller of the SIMATIC CPU 300 type.

5. Check the standard entry of the addresses.
Change the entries, if required.
6. Click "OK".
The entries are saved. The dialog box closes.

Result

The switch states of the digital inputs of the HMI device are stored in the specified address area of the controller.

6.4.5 Setting the properties of the digital inputs/outputs

Requirement

- A project is open in "HW Config".

Procedure

1. Double-click slot 4 in the detailed view.
The dialog box "Properties – 16 DI/DO DC24V" is displayed.
2. Select the "General" tab.

Parameter	Meaning
Name	The name is displayed in the detail view, "Module" column
Comment	The name is displayed in the detail view, "Comment" column

3. Change the entries, if required.
4. Select the "Parameters" tab.
5. Open the "Parameters > Device-specific parameters" folder.

Parameter	Meaning
Function of terminal 16 (IO.16)	Adjustable: Input or output, default setting is input
...	Adjustable: Input or output, default setting is input
Function of terminal 31 (IO.31)	Adjustable: Input or output, default setting is input

6. Change the entries, if required.
7. Open the "Addresses" tab.

In the "Inputs" and "Outputs" groups, the start values of the address areas are set depending on the controller used. The signals of the HMI device are mapped in these address ranges.

Parameter	Meaning
Inputs > Start	Start of the address range in which the user data of the HMI device are mapped.
Inputs > Process Image	Process image to which the address range belongs. This parameter cannot be entered with a controller of the SIMATIC CPU 300 type.
Outputs > Start	Start of the address range in which the user data of the HMI device are mapped.
Outputs > Process Image	Process image to which the address range belongs. This parameter cannot be entered with a controller of the SIMATIC CPU 300 type.

8. Check the standard entry of the addresses.
Change the entries, if required.
9. Click "OK".
The entries are saved. The dialog box closes.

Result

The switch states of the digital inputs/outputs of the HMI device are stored in the specified address area of the controller.

6.4.6 Setting the fail-safe properties

This step applies to the fail-safe slot 5.

You can delete slot 5 in the detailed view in HW Config. If slot 5 has been deleted, you can operate the KP32F in non fail-safe operation.

Requirement

- You know the password for the safety program.
- A project is open in "HW Config".

Procedure

1. Double click in the properties window on slot 5.
The "Properties – F-DI" dialog box is displayed.
2. Select the "General" tab.

Parameter	Meaning
Name	The name is displayed in the detail view, "Module" column
Comment	The name is displayed in the detail view, "Comment" column

3. Change the entries, if required.

4. Open the "Addresses" tab.

In the "Inputs" and "Outputs" groups, the start values of the address areas are set depending on the controller used. The signals of the F channels of the HMI device are mapped in these address ranges.

Parameter	Meaning
Inputs > Start	Start of address range in which the safety-relevant usage data of the HMI device are mapped.
Inputs > Process Image	Process image to which the address range belongs. This parameter cannot be entered with a controller of the SIMATIC CPU 300 type.
Outputs > Start	Start of address range in which the safety-relevant data of the HMI device are mapped.
Outputs > Process Image	Process image to which the address range belongs. This parameter cannot be entered with a controller of the SIMATIC CPU 300 type.

5. Check the default entry of the addresses for "Start".
If necessary, change the address range.
6. Select the "Parameters" tab.
7. Open the "Parameters > Device-specific Panels > Evaluation of the sensors" directory.
8. In the "Value" column select the entry for the connected sensor according to section "Connecting KP32F - fail-safe inputs (Page 58)":
 - [101h], FI.0.FI.1 disabled, FI.2.FI.3 disabled
 - [8484h], FI.0.FI.1 1oo1, FI.2.FI.3 disabled
 - [D3D3h], FI.0.FI.1 1oo2, FI.2.FI.3 disabled
 - [5454h], FI.0.FI.1 1oo2, FI.2.FI.3 1oo2
 - [4A4Ah], FI.0.FI.1 1oo2, FI.2.FI.3 1oo1
 - [9898h], FI.0.FI.1 1oo1, FI.2.FI.3 1oo1

Note

Make sure that the sensor is monitored corresponding with its connection.

9. Note the value returned in the square brackets.

10. Open the "PROFIsafe" tab.

When you open a project for the first time, the following dialog appears.



11. Enter the corresponding password.

Enter the password that was assigned when the safety program was created in Distributed Safety.

12. Click "OK".

The content of the "PROFIsafe" tab is changed.

13. Select the parameter name "F_iPar_CRC".

14. To do this, use the "Change value" button.

One of the following dialogs is opened.

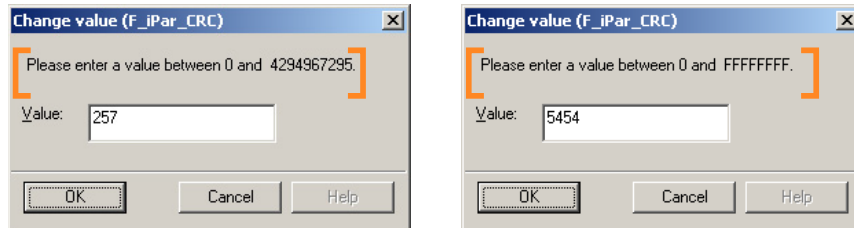

Please note the numerical range of the marked text in the dialog. If the range of numbers is hexadecimal, enter the necessary hexadecimal value.

If the range of numbers is decimal, enter the decimal value according to the following table.

Input value, hexadecimal	Associated decimal input value
101	257
8484	33924
D3D3	54227
5454	21588
4A4A	19018
9898	39064

15. Click "OK".

The entries are saved. The dialog box closes.

16. If necessary, change the "F_Dest_Add" parameter.

To do this, use the "Change value" button. Assign a network and station-wide unique address.

6.5 Setting the PROFIsafe address

17. Change the monitoring time "F_WD_Time" if needed.

To do this, use the "Change value" button. Assign a network and station-wide unique address.

18. Click "OK".

The entries are saved. The dialog box closes.

Result

The switch states of the digital inputs of the HMI device are stored in the specified address area of the controller.

See also

Connecting the EMERGENCY STOP button (Page 58)

6.5 Setting the PROFIsafe address

A PROFIsafe target address is assigned when you add the HMI device in the HW Config of the STEP 7 project. The PROFIsafe target address is the value of the "F_Dest_Add" parameter – KP8F see section "Setting the fail-safe properties (Page 89)" and KP32F see section "Setting the fail-safe properties (Page 89)".

Then you must set the same PROFIsafe target address using the DIP switch on the back of the HMI device.

Note

Ensure that the HMI device is disconnected from the power before setting the PROFIsafe target address with the DIP switches.

Requirement

- The DIP switch of the HMI device is accessible.
- The value of the "F_Dest_Add" parameter is known.

Note

The PROFIsafe target address of the HMI device must be unique throughout the communication network and station. You can assign a maximum of 1022 PROFIsafe target addresses in a single system.

If you change the STEP 7 program in a way that changes the PROFIsafe target address, you need to change the switch settings on the HMI device's DIP switch accordingly.

Example

In the HW Config of the STEP 7 project, set the binary address for "383" as the PROFIsafe-target address:

Corresponding setting on the DIP switch: 0101111111

- 1 = switch setting "ON"
- 0 = switch setting "OFF".

Set the DIP switch on the back of the KP8F or the KP32F as follows:

OFF	ON	Switch	Bit number	Weighting	Address
<input type="checkbox"/>	<input checked="" type="checkbox"/>	1	0	1	1
<input type="checkbox"/>	<input checked="" type="checkbox"/>	2	1	2	2
<input type="checkbox"/>	<input checked="" type="checkbox"/>	3	2	4	4
<input type="checkbox"/>	<input checked="" type="checkbox"/>	4	3	8	8
<input type="checkbox"/>	<input checked="" type="checkbox"/>	5	4	16	16
<input type="checkbox"/>	<input checked="" type="checkbox"/>	6	5	32	32
<input type="checkbox"/>	<input checked="" type="checkbox"/>	7	6	64	64
<input checked="" type="checkbox"/>	<input type="checkbox"/>	8	7	128	0
<input type="checkbox"/>	<input checked="" type="checkbox"/>	9	8	256	256
<input checked="" type="checkbox"/>	<input type="checkbox"/>	10	9	512	0

383

The illustrated switch settings correspond with the binary address 383.

Result

The HMI device can be uniquely identified by the configured PROFIsafe target address.

6.6 Assigning parameters for Media Redundancy Protocol and Isochronous Real-Time

KP8, KP8F and KP32F are designed for MRP and IRT.

See the STEP 7 Online Help for a description of how to configure MRT and IRT in STEP 7. You will find detailed information in the following manual:

You can find additional information on device names and device number in the manual "SIMATIC PROFINET System Description (<http://support.automation.siemens.com/WW/view/en/19292127>)".

Fail-safe operation of KP8F and KP32F

7.1 Overview

Fail-safe mode

In fail-safe mode the HMI device recognizes signal states from suitable fail-safe sensors and sends corresponding safety telegrams to the fail-safe controller where the safety program runs. The fail-safe controller and the HMI device communicate with each other using the fail-safe protocol "PROFIsafe".

Safety functions

During fail-safe mode, safety functions are activated in both HMI and the fail-safe controller which recognize faults and react to them.

In the following cases, the fitting system unit must be run in a secure operating state:

- The EMERGENCY STOP button is pressed.
- An sensor was actuated.
- A diagnosable error has occurred.

Reaction to pressed EMERGENCY STOP buttons or activation of sensor

If the EMERGENCY-STOP button was pressed or sensor was activated, the related BIT is sent to the controller in a safety-related manner. The controller program analyzes if the EMERGENCY STOP button was pressed or the sensor was activated.

Note

Which reactions this bit activates in the controller and thus, in the system, is the task of the user. Tasks include:

- Configuring required responses appropriate for the EMERGENCY STOP in the controller
- Setting measures to repair the cause of an EMERGENCY STOP
- Configuring the startup behavior after an EMERGENCY STOP

The response to an EMERGENCY STOP or activation of the sensor, measures and startup behavior must be described in the system documentation.

Responses to faults in the system

In the case of a failure, the F channels of the HMI device are passivated. This means "0" will be recognized at all fail-safe digital inputs.

The system must be configured so that the required safe operating mode can occur. Which measures must be implemented for failure analysis and repairs must be provided by the user.

Note

The HMI device may first be integrated into the control process after the causes for the failure have been repaired.

After integration, the process values for the digital fail-safe inputs are available again.

7.2 Passivate HMI device

As soon as the HMI device recognizes a fault in fail-safe mode, all fail-safe channels are switched to the safe operating state. Through this, the fail-safe channels of this HMI device are passivated.

Note

If the HMI device is passivated, instead of the queued process values, the fail-safe value "0" is always assigned to all the fail-safe digital inputs. You cannot assign parameters for the fail-safe value.

Detected faults are entered in the diagnostic buffer of the fail-safe controller and reported to the safety program in the fail-safe controller.

The HMI device cannot permanently save the fault. When you switch off the HMI device and switch it on again, only one of the existing faults will continue to be detected after startup. If you want to save the faults, program your safety program accordingly.

The HMI device is passivated in the following situations:

- After turning on the HMI device
- With a setting error

Errors in the PROFIsafe parameters, for example "F_WD_TIME" (F_monitoring time) too short.

- When an error occurs in the PROFIsafe communication between the fail-safe controller and HMI device
- With a hardware error

Error, for example, through wire break, short-circuit, discrepancy errors, internal errors of the HMI device.

Determining passivation

If you want to determine if the HMI device is passive or not, address the "PASS_OUT" variable of the F-I/O. The variable can be assigned the following values:

- 0 = HMI device not passive
- 1 = HMI device passive

Reintegration of KP8F and KP32F

After passivation of the HMI device, the fault must be diagnosed and rectified. Afterwards, the HMI device can be reintegrated.

7.3 Error diagnostics

Diagnostic functions

Diagnostic functions, in other words displays and messages, are not critical to safety and therefore are not designed to be safety-related functions. They are therefore not tested internally.

Diagnostic function the HMI device

The fail-safe HMI device includes a non-configurable diagnostic function. The diagnostics are always activated and are automatically made available by the HMI device in STEP 7 and passed on to the controller in the event of a fault.

The diagnostics function passes the following diagnostics information to the controller:

- Communication error
The communication between the HMI device as the IO-device and the controller as the IO-controller is disrupted.
- Configuration error
Error in the PROFIsafe configuration

Reading diagnostic information

If you wish to locate the cause of an error, open the module diagnostics in STEP 7. You can find detailed information in the online help for STEP 7.

The following table shows the diagnostic functions of the HMI device. The diagnostic functions are assigned either to one channel or to the entire module.

Diagnosics function	Error code	Scope of diagnostics functions
Short-circuit	0x01	Channel
Configuration error	0x10	Module
Communication error	0x13	Module
Discrepancy error	0x19	Channel
Non-permissible sensor evaluation	0x1C	Module
PROFIsafe address deviation	0x1D	Module
Serious error	0x1E	Module
Version conflict	0x1F	Module

You have the option of reading the diagnostics functions in the standard program by calling SFB 52 or SFB 54. For detailed information, refer to the "System and Standard Functions" reference manual.

Diagnostics of PROFIsafe errors

When diagnosing PROFIsafe errors, address the "DIAG" variable of the F-I/O DB. Detailed information about the F-I/O-DB can be found in the Programming and operation manual "S7 Distributed Safety - Configuring and Programming" (<http://support.automation.siemens.com/WW/view/en/22099875>).

HMI device with a serious error

If a serious error in the HMI device leads to its failure, the HMI device reacts as follows:

- The connection to PROFINET will be interrupted and the fail-safe channels will be rendered passive.
- No diagnosis will be transmitted from the HMI device.

In STEP 7 in module diagnostics, the standard diagnosis "Module interrupted" or "Module missing" will be reported.

7.4 Repair error and reintegrate

Remedy

The error correction of the HMI device should be undertaken depending on the type of error recognized:

Error	Possible causes of error	Remedy
Short-circuit	Short-circuit in the sensor	Eliminate the short-circuit.
	Cross-circuit in the sensor	Eliminate the cross-circuit.
	Internal error	Replace the HMI device.
Serious error	Internal error in the HMI device	Replace the HMI device.
Discrepancy error (1oo2 evaluation)	The process signal is faulty. The sensor is defective.	Check the process signal. Replace the sensor if needed.
	Short-circuit between the sensor line and the sensor voltage supply line.	Eliminate the short-circuit.
Configuration error	The HMI device does not match the configuration.	Correct the configuration. Check the communication paths.
	Configuration incorrect	Correct the configuration.
PROFIsafe address deviation	The PROFIsafe address on the HMI device is set incorrectly.	Set the same PROFIsafe address in the SIMATIC manager, HW Config and on the device. This address must be unique. See section "Setting the PROFIsafe address (Page 92)".
Communication error	The communication between the fail-safe controller and HMI device is interrupted, for example, due to a defective PROFINET connection or EMI.	Check the PROFINET cable.
	The PROFIsafe monitoring time set too low.	Increase the value of the "F_WD_Time" parameter in the SIMATIC Manager, HW Config.
	The configuration of the HMI device does not match the safety program.	Compile the safety program again. Then download the configuration and the safety program to the fail-safe controller.
Non-permissible sensor evaluation	An invalid value was transferred for the setting "Evaluation of the sensor".	Check the setting. Check the version of your GSDML-file. Load a new GSDML file.
Version conflict	The HMI device recognized an invalid combination of firmware.	Update the device firmware completely and bring it to the current state.

End passivation

When you have eliminated an error that lead to a passivation of the HMI device, you have to reintegrate the HMI device. A user acknowledgement in the safety program may be required for the reintegration of the HMI device. After reintegration, the pending process values at the HMI device's fail-safe channels are provided again for the safety program.

More information about the reintegration of F-I/O and for creating a user acknowledgement in the safety program can be found in the Programming and operation manual "S7 Distributed Safety - Configuring and Programming" (<http://support.automation.siemens.com/WW/view/en/22099875>).

7.5 Response times of the PROFIsafe devices

Influencing the response time

The response time of the HMI device enters into the calculation of the response time of the F-system.

- Response times of the fail-safe channels

The response time is the time that is required between a signal change on the digital input and the safe loading of the safety message frame to PROFINET.

- Response time of the HMI device

The actual response time is somewhere between the shortest and longest response time. When planning a system, the longest response time must always be anticipated. Information about the response time can be found in the section "Technical specifications (Page 107)".

The following image shows where response times can be expected.

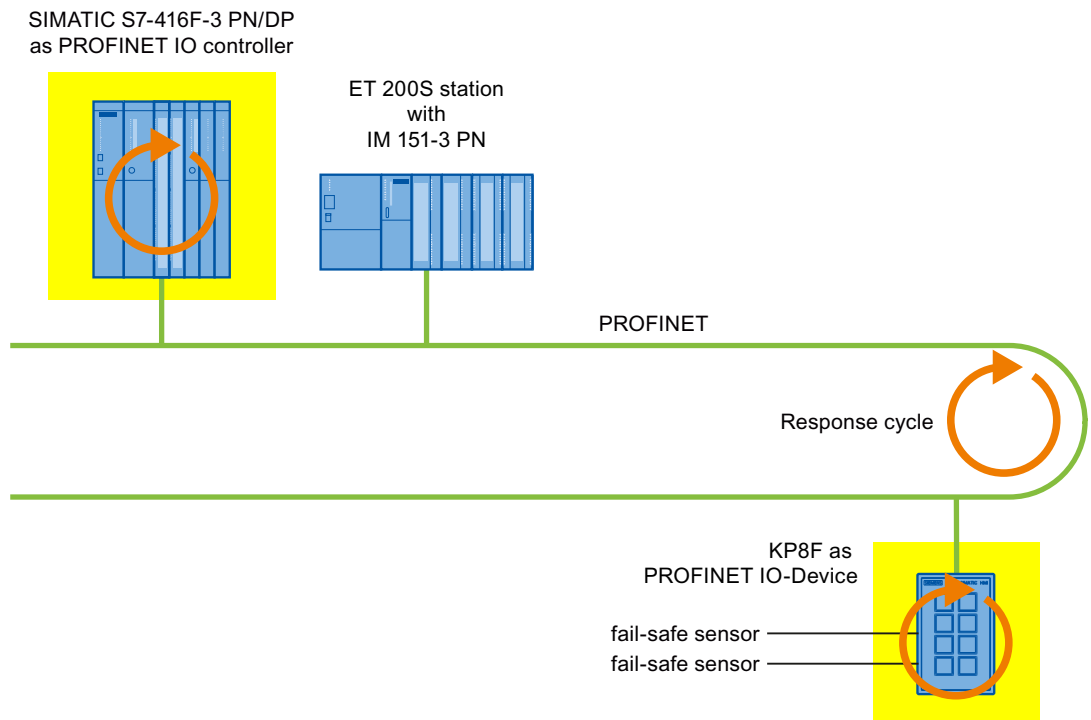

Calculating response time

Information about the response times of the IO controller can be found in the manual of the IO controller used.

The "S7 Distributed Safety" add-on package contains an Excel file "s7fcotia.xls" for calculating maximum response times. You can find the current version of this table on the Internet at the following address:

"s7coti (<http://support.automation.siemens.com/WW/view/en/19138505>)",
Entry -ID 19138505

Detailed information for the calculation of the response time of the F-system can be found in the "Safety Technology in SIMATIC S7" system manual (<http://support.automation.siemens.com/WW/view/en/12490443>)".

HMI device maintenance and repair

8.1 Service

Observe the safety instructions during maintenance found in section "Safety Instructions (Page 23)".

Scope of maintenance

The HMI device is designed for maintenance-free operation. Cyclic maintenance work is not required. But you should still clean the keyboard membrane.

Procedure

CAUTION
Damage possible Using compressed air or steam cleaners, or aggressive solvents or scouring agents will damage the HMI device. Use a cleaning cloth dampened with a cleaning agent to clean the equipment. Only use water with a little liquid soap or a screen cleaning foam.

Proceed as follows:

1. Switch off the HMI device.
2. Spray the cleaning solution onto a cleaning cloth.
Do not spray directly onto the HMI device.
3. Clean the HMI device.

8.2 Spare parts and repairs

If the unit needs to be repaired, ship the HMI device to the Return Center in Fürth.

The address is:

Siemens AG
Industry Sector
Retouren-Center
Siemensstr. 2
90766 Fürth
Germany

You can find more detailed information on the Internet at Spare parts and repairs (<http://support.automation.siemens.com/WW/view/en/16611927>).

Technical specifications

9.1 Dimension drawing KP8, KP8F

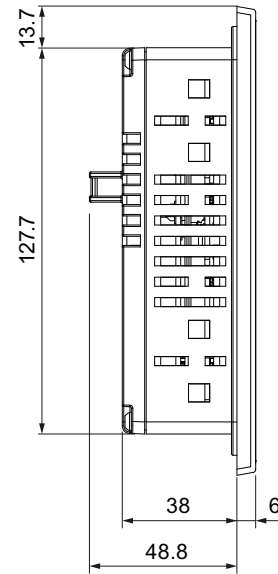
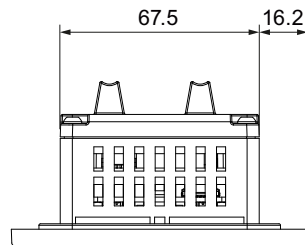
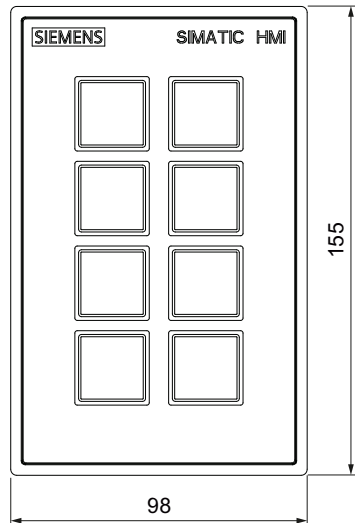

All dimensions in mm.

You can find more images on the Internet at:

Image database (<http://www.automation.siemens.com/bilddb>)

9.2 Dimension drawing KP32F

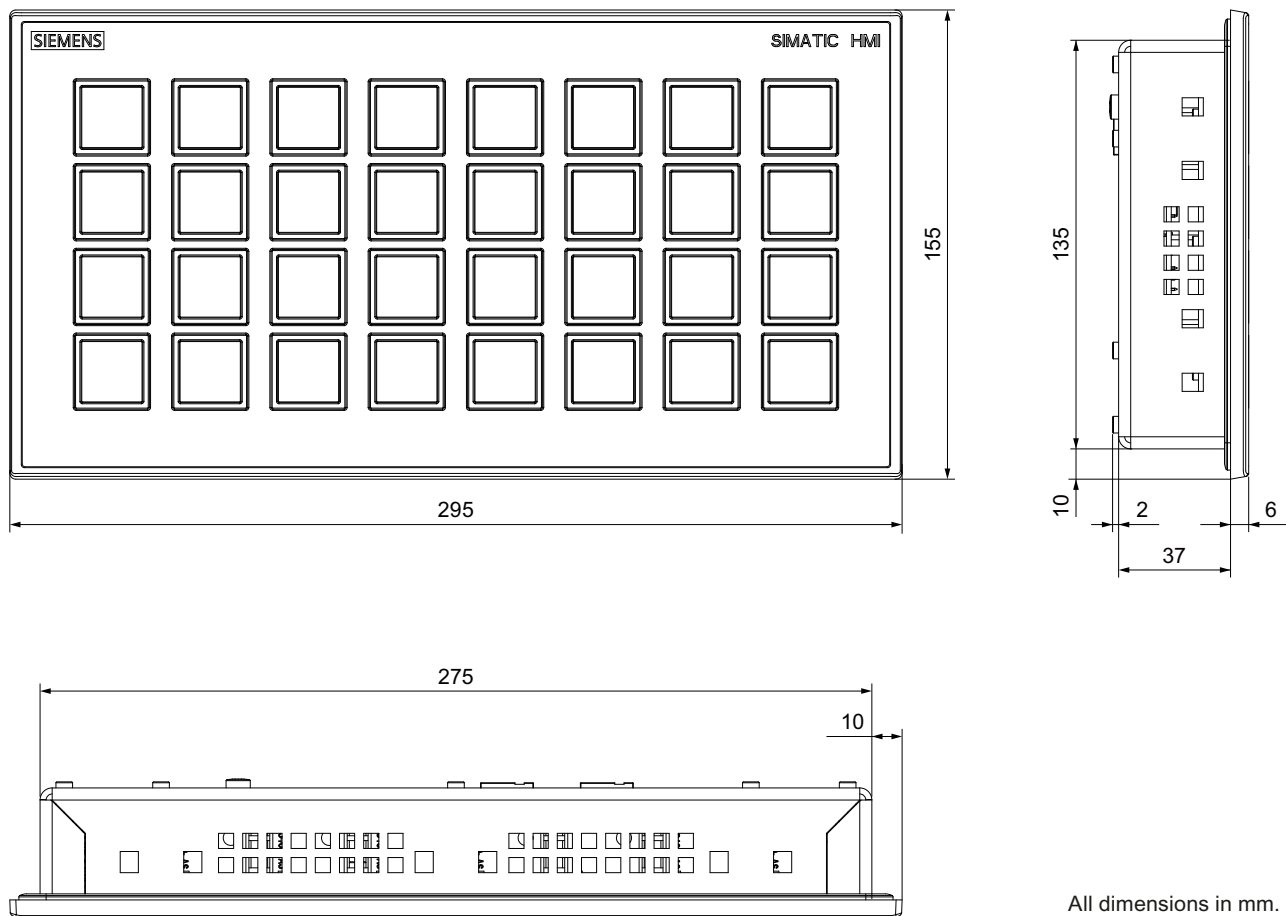

All dimensions in mm.

You can find more images on the Internet at:

Image database (<http://www.automation.siemens.com/bilddb>)

9.3 Technical specifications

Weight

KP8, including connector and mounting clamps, without packaging	270 g
KP8F, including connector and mounting clamps, without packaging	280 g
KP32F, including connector and mounting clamps, without packaging	1,220 g

Power supply

Physical variable	KP8, KP8F	KP32F
Nominal value	+24 VDC	
Voltage range, permitted	+20.4 V to +28.8 V (-15 %, +20 %)	
Current consumption, without load	≤ 0.3 A	≤ 1.0 A
Electrical isolation	No	
Short-circuit protection	Yes	
Transients, maximum permissible	35 V, 500 ms	
Time between two transients	≥ 50 s	
Fuse, internal	4 A	

Sensor

Physical variable	KP8, KP8F	KP32F
Signal duration	≥ 50 ms	

KP8 and KP32F in non fail-safe operation - digital inputs/outputs

Physical variable	KP8, KP8F	KP32F
Connectable	Keys, switches	
Number of digital inputs, standard mode	0	16
Number of digital inputs/outputs, standard mode	8	16
Electrically isolated from internal logic	No	
Cable length	<ul style="list-style-type: none"> • Unshielded cable ≤ 3 m • Shielded cable ≤ 10 m 	
Input current with "1" signal and 24 V	5 mA, typical	
Delay in the digital inputs/outputs	0.3 ms	
Bounce time	≤ 10 ms	

9.3 Technical specifications

Physical variable	KP8, KP8F	KP32F
<ul style="list-style-type: none"> Permitted resistive loads Lamp load, permissible 	0.1 A 2 W	
Energy, inductive	≤ 200 mWs	
Output voltage	≤ 2 V, in no-load operation Supply voltage ≥ 3 V	
<ul style="list-style-type: none"> With "0" signal With "1" signal 		
Output current	≤ 1 mA Cumulative current for all outputs 800 mA	
<ul style="list-style-type: none"> With "0" signal With "1" signal 		
Switching frequency, max. at		
<ul style="list-style-type: none"> Resistive load Lamp load 	100 Hz 8 Hz	

KP8 and KP32F – fail-safe digital inputs/outputs

In addition, the following applies to fail-safe digital inputs with KP8F and KP32F:

Physical variable	KP8, KP8F	KP32F
Number of fail-safe digital inputs	2	4
Number of fail-safe outputs	Corresponding to PROFIsafe process values	
Cable length		
<ul style="list-style-type: none"> Unshielded cable Shielded cable 	≤ 1 m ≤ 3 m	≤ 3 m ≤ 10 m
Response time for 1oo1 and 1oo2 if there are no faults	6 to 22 ms	
Response time for 1oo1 and 1oo2 in the event of a fault	10 to 27 ms	
Acknowledgment time in safety mode	15 to 35 ms	
Signal duration, minimum	22 ms	

9.4 Fail-safe mode

KP8F and KP32F internally

The block diagram:

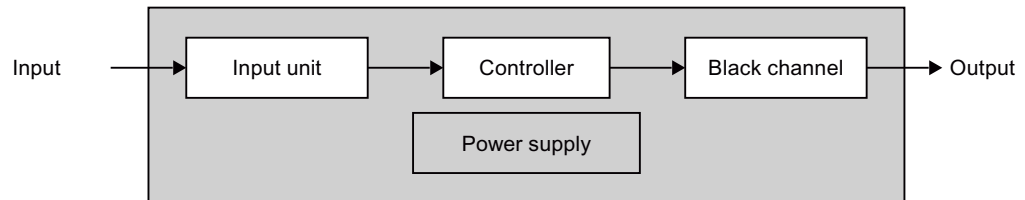

The relevant values of the individual blocks are shown in the following.

Note

All values for the following data are based on the SN 29500:2005 and an ambient temperature of 60 °C.

Input unit – 1oo1 mode

Parameter	Value	Comment
Hardware Fault Tolerance	0	–
Classification	A	–
Architecture	1oo1D	–
Failure mode	Dangerous process value	Due to failures in the input circuit
<ul style="list-style-type: none"> • Detected • Undetected 	<ul style="list-style-type: none"> • 5.50 FIT • 0.34 FIT 	
Failure Mode Diagnostic	No error signaling or no safe values	Calculation according IEC 13849-1, CAT4
<ul style="list-style-type: none"> • Detected • Undetected 	<ul style="list-style-type: none"> • 0 FIT • 0 FIT 	
Diagnostic Coverage	94.15 %	–
Diagnostic test interval	15 ms	Errors detected in each firmware cycle
Safe Failure Fraction	99.19 %	–

Input unit – 1oo2 mode

Parameter	Value	Comment
Hardware Fault Tolerance	1	–
Classification	A	–
Architecture	1oo2D	1st detected failure leads to the safe state
Failure mode <ul style="list-style-type: none"> • Detected • Undetected 	Dangerous process value <ul style="list-style-type: none"> • 5.78 FIT • 0.06 FIT 	Due to failures in the input circuit One channel One channel
Failure Mode Diagnostic <ul style="list-style-type: none"> • Detected • Undetected 	No error signaling or no safe values <ul style="list-style-type: none"> • 0 FIT • 0 FIT 	Calculation according IEC 13849-1, CAT4
Diagnostic Coverage	99.00 %	–
Diagnostic test interval	15 ms	Errors detected in each firmware cycle
Safe Failure Fraction	99.86 %	–
Common Cause Factor	2 %	–

Controller

Parameter	Value	Comment
Hardware Fault Tolerance	1	–
Classification	B	–
Architecture	1oo2D	1st detected failure leads to the safe state
Failure mode <ul style="list-style-type: none"> • detected • undetected 	Dangerous process value <ul style="list-style-type: none"> • 174,00 FIT • 1,68 FIT 	Due to failures in the processing unit <ul style="list-style-type: none"> • One channel • One channel
Failure Mode Diagnostic <ul style="list-style-type: none"> • Detected • Undetected 	No error signaling or no safe values <ul style="list-style-type: none"> • 0 FIT • 0 FIT 	Calculation according IEC 13849-1, CAT4
Diagnostic Coverage	99.04 %	–
Diagnostic test interval	15 ms	Errors detected in each firmware cycle
Safe Failure Fraction	99.23 %	–
Common Cause Factor	2 %	–

Power supply

Parameter	Value	Comment
Hardware Fault Tolerance	0	–
Classification	A	–
Architecture	1oo1D	–
Failure mode • Detected • Undetected	Dangerous process value • 22.50 FIT • 0.22 FIT	Due to failures in the power supply
Failure Mode Diagnostic • Detected • Undetected	No error signaling or no safe values • 0 FIT • 0 FIT	Calculation according IEC 13849-1, CAT4
Diagnostic Coverage	99.03 %	–
Diagnostic test interval	< 10 ms	Voltage monitoring in hardware
Safe Failure Fraction	99.84 %	–

Fail-safe mode for 1oo1 evaluation

- According to IEC 61508

Systematic Capability	SIL3
Mode of operation	High and low demand mode
Meantime to Restoration (MTTR)	100 h
Probability of a dangerous failure per hour (PFH)	5.95×10^{-10} 1/h
Probability of a dangerous failure on demand (PFD)	2.61×10^{-5}
Safe Failure Fraction (SFF)	99.19 %
Diagnostic test interval	15 ms
Proof Test Interval	10 y
Lifetime	10 y

- According to IEC 13849-1

Meantime to Failure (MTTF _d)	560 y
Meantime to Restoration (MTTR)	100 h
Diagnostic Coverage (DC _{avg})	98.90 %
Performance Level	d
Category	3

- According to EN 954-1

Category	3
----------	---

Fail-safe mode for 1oo2 evaluation

- According to IEC 61508

Systematic Capability	SIL3
Mode of operation	High and low demand mode
Meantime to Restoration (MTTR)	100 h
Probability of a dangerous failure per hour (PFH)	2.55×10^{-10} 1/h
Probability of a dangerous failure on demand (PFD)	1.11×10^{-5}
Safe Failure Fraction (SFF)	99.23 %
Diagnostic test interval	15 ms
Proof Test Interval	10 y
Lifetime	10 y

- According to IEC 13849-1

Meantime to Failure (MTTF _d)	560 y
Meantime to Restoration (MTTR)	100 h
Diagnostic Coverage (DC _{avg})	99.04 %
Performance Level	e
Category	4

- According to EN 954-1

Category	4
----------	---

9.5 Interface description

9.5.1 KP8, inputs/outputs

X60, connector, 12-pin

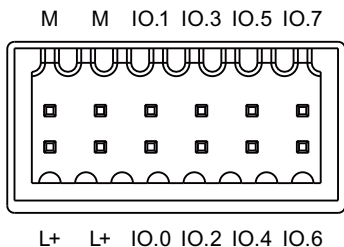

Pin number	Pin	Assignment
1	L+	+24 VDC
2	M	Ground
3	L+	+24 VDC
4	M	Ground
5	IO.0	digital input/output 0
6	IO.1	digital input/output 1
7	IO.2	digital input/output 2
8	IO.3	digital input/output 3
9	IO.4	digital input/output 4
10	IO.5	digital input/output 5
11	IO.6	digital input/output 6
12	IO.7	digital input/output 7

9.5.2 KP8F, inputs/outputs

X60, connector, 16-pin

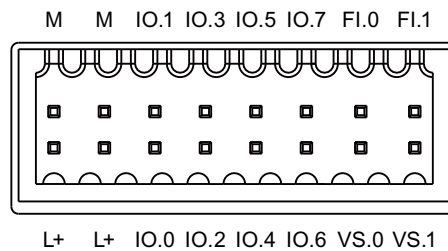

Pin number	Pin	Assignment
1	L+	+24 VDC
2	M	Ground
3	L+	+24 VDC
4	M	Ground
5	IO.0	digital input/output 0
6	IO.1	digital input/output 1
7	IO.2	digital input/output 2
8	IO.3	digital input/output 3
9	IO.4	digital input/output 4
10	IO.5	digital input/output 5
11	IO.6	digital input/output 6
12	IO.7	digital input/output 7
13	FI.0	Fail-safe digital input 0
14	FI.1	Fail-safe digital input 1
15	VS.0	Sensor supply 1 for FI.0
16	VS.1	Sensor supply 2 for FI.1

9.5.3 KP32F

9.5.3.1 Power supply

Plug connector, 2-pin



Pin number	Assignment
1	+24 VDC (L+)
2	GND 24 V (M)

9.5.3.2 Inputs

X60, connector, 16-pin

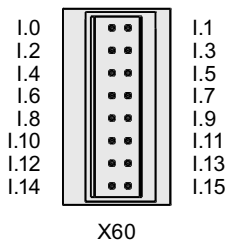

Pin number	Pin	Assignment
1	I.0	Digital input 0
2	I.1	Digital input 1
...
15	I.14	Digital input 14
16	I.15	Digital input 15

9.5.3.3 Input and outputs

X61, connector, 24-pin

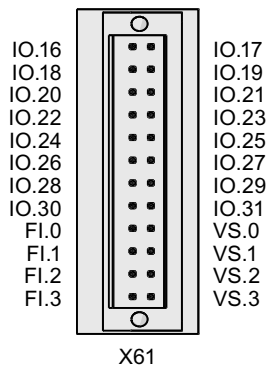

Pin number	Pin	Assignment
1	I0.16	digital input/output 16
2	I0.17	digital input/output 17
...
15	I0.30	digital input/output 30
16	I0.31	digital input/output 31
17	FI.0	Fail-safe digital input 0
18	VS.0	Sensor supply 0 for FI.0
19	FI.1	Fail-safe digital input 1
20	VS.1	Sensor supply 1 for FI.1
21	FI.2	Fail-safe digital input 2
22	VS.2	Sensor supply 2 for FI.2
23	FI.3	Fail-safe digital input 3
24	VS.3	Sensor supply 3 for FI.3

9.5.4 PROFINET

X1, RJ45 socket, 8-pin

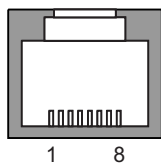

Pin number	Pin	Assignment
1	RxP	Receive data +
2	RxN	Receive data –
3	TxP	Transmit data +
4	GND	n. c.
5	GND	n. c.
6	TxN	Transmit data –
7	GND	n. c.
8	GND	n. c.

9.6 KP8 and KP8F - Bit assignment in the process image

The signal states of HMI device digital inputs/outputs that are used in standard mode are saved in their own process images independently from the signal states of the fail-safe channels.

Input area of the controller

The keys and digital inputs of the HMI device are mapped to the bits in the input area of the controller as follows:

Bit 7	Bit 6	Bit 5	Bit 4	Bit 3	Bit 2	Bit 1	Bit 0	Description	Input
K 7	K 6	K 5	K 4	K 3	K 2	K 1	K 0	Keys 0 to 7	Byte 0
DI 7	DI 6	DI 5	DI 4	DI 3	DI 2	DI 1	DI 0	Digital inputs 0 to 7	Byte 1

K = Key

DI = Digital input

The numbering refers to the specifications in the chapter "Front-sided control elements and displays (Page 65)".

Output area of the controller

Each of the three questions has its own output byte. The LEDs are assigned to the bits in the output area of the controller as follows:

Bit 7	Bit 6	Bit 5	Bit 4	Bit 3	Bit 2	Bit 1	Bit 0	Description	Output
R 7	R 6	R 5	R 4	R 3	R 2	R 1	R 0	LEDs 0 to 7, red	Byte 0
G 7	G 6	G 5	G 4	G 3	G 2	G 1	G 0	LEDs 0 to 7, green	Byte 1
B 7	B 6	B 5	B 4	B 3	B 2	B 1	B 0	LEDs 0 to 7, blue	Byte 2
DO 7	DO 6	DO 5	DO 4	DO 3	DO 2	DO 1	DO 0	Digital outputs 0 to 7	Byte 3

R = Red

G = Green

B = Blue

DO = Digital output

For the output bytes 0 to 2, the bit combinations of the bit x are illustrated in the following table.

Bit R x (red, byte 0)	Bit G x (green, byte 1)	Bit B x (blue, byte 2)	LED
1	0	0	Red
0	1	0	Green
0	0	1	Blue
1	1	0	Yellow
1	1	1	White
0	0	0	OFF
1	0	1	OFF
0	1	1	OFF

9.7 KP8F – Encoder evaluation of the fail-safe channels

Note

For digital inputs that are reserved with a fail-safe channel, the process image described in the chapter "KP8 and KP8F - Bit assignment in the process image (Page 116)" is **not** used.

The fail-safe channels occupy the following address areas in the process image of the fail-safe controller:

Input area	Output area
x + 0 to x + 4	x + 0 to x + 3

- x The start address for the input and output range.
The address was entered on the "Addresses" tab in the HW Config in the object properties of the module "KP8F, Slot 2".

The first byte in the process image describes the switch state of the connected sensors or a connected EMERGENCY-OFF button. The setting is described in the section "KP8F – Setting the fail-safe properties (Page 77)".

Note

The unused bits in the byte 0 are always "0".

The following evaluations are possible:

- No evaluation

Slot 2 was not set. No evaluation occurs.

SIL2				SIL3				First byte
Bit 7	Bit 6	Bit 5	Bit 4	Bit 3	Bit 2	Bit 1	Bit 0	

- 1001 evaluation

The slot 2 was set with "1001 (1v1)-evaluation, one-channel". The connected sensor is evaluated.

SIL2				SIL3				First byte
Bit 7	Bit 6	Bit 5	Bit 4	Bit 3	Bit 2	Bit 1	Bit 0	

FI.1
FI.0
↓
↓

Bits 4 and 5 determine if the respective sensor contact is open or closed. The bits may take on the following values:

- 0 = Open sensor contact
- 1 = sensor contact closed

- 1002 evaluation

The slot 2 was set with "1002 (2v2)-evaluation, EMERGENCY STOP". The EMERGENCY STOP button is evaluated.

SIL2				SIL3				First byte
Bit 7	Bit 6	Bit 5	Bit 4	Bit 3	Bit 2	Bit 1	Bit 0	

FI.0
FI.1

Bit 0 determines whether or not the EMERGENCY STOP button was pressed. The bit can take on the following values:

- 0 = EMERGENCY STOP button pressed or error
- 1 = EMERGENCY STOP button **not** pressed

9.8 KP32F - Bit assignment in the process image

The signal states of HMI device digital inputs/outputs that are used in standard mode are saved in their own process images independently from the signal states of the fail-safe channels.

Input area of the controller

See figure in section "Front-sided control elements and displays (Page 65)". The keys and digital inputs of the HMI device are mapped to the bits in the input area of the controller as follows:

Input area, slot 1

Bit 7	Bit 6	Bit 5	Bit 4	Bit 3	Bit 2	Bit 1	Bit 0	Description	Input
K07	K06	K05	K04	K03	K02	K01	K00	Keys 0 to 7	Byte 0
K15	K14	K13	K12	K11	K10	K09	K08	Keys 8 to 15	Byte 1

Input area, slot 2

Bit 7	Bit 6	Bit 5	Bit 4	Bit 3	Bit 2	Bit 1	Bit 0	Description	Input
K23	K22	K21	K20	K19	K18	K17	K16	Keys 16 to 23	Byte 0
K31	K30	K29	K28	K27	K26	K25	K24	Keys 24 to 31	Byte 1

K = Key

The numbering of the keys refers to the specifications in the section "Front-sided control elements and displays (Page 65)".

Digital inputs, slot 3

Bit 7	Bit 6	Bit 5	Bit 4	Bit 3	Bit 2	Bit 1	Bit 0	Description	Input
DI07	DI06	DI05	DI04	DI03	DI02	DI01	DI00	Input 0 to 7	Byte 0
DI15	DI14	DI13	DI12	DI11	DI10	DI09	DI08	Input 8 to 15	Byte 1

Digital inputs, slot 4

Bit 7	Bit 6	Bit 5	Bit 4	Bit 3	Bit 2	Bit 1	Bit 0	Description	Input
DI23	DI22	DI21	DI20	DI19	DI18	DI17	DI16	Input 16 to 23	Byte 0
DI31	DI30	DI29	DI28	DI27	DI26	DI25	DI24	Input 24 to 31	Byte 1

DI = Digital input

Output area of the controller

Each of the three questions has its own output byte. The LEDs are assigned to the bits in the output area of the controller as follows:

For the DOe output bytes 0 to 2, the DOe bit combinations of the bit x are illustrated in the following table.

Bit R x (red, byte 0)	Bit G x (green, byte 1)	Bit B x (blue, byte 2)	LED
1	0	0	Red
0	1	0	Green
0	0	1	Blue
1	1	0	Yellow
1	1	1	White
0	0	0	OFF
1	0	1	OFF
0	1	1	OFF

Output area, slot 1

Bit 7	Bit 6	Bit 5	Bit 4	Bit 3	Bit 2	Bit 1	Bit 0	Description	Output
D07	D06	D05	D04	D03	D02	D01	D00	LEDs 0 to 7, red	Byte 0
D07	D06	D05	D04	D03	D02	D01	D00	LEDs 0 to 7, green	Byte 1
D07	D06	D05	D04	D03	D02	D01	D00	LEDs 0 to 7, blue	Byte 2

Bit 7	Bit 6	Bit 5	Bit 4	Bit 3	Bit 2	Bit 1	Bit 0	Description	Output
D15	D14	D13	D12	D11	D10	D09	D08	LEDs 8 to 15, red	Byte 3
D15	D14	D13	D12	D11	D10	D09	D08	LEDs 8 to 15, green	Byte 4
D15	D14	D13	D12	D11	D10	D09	D08	LEDs 8 to 15, blue	Byte 5

D = LED

Output area, slot 2

Bit 7	Bit 6	Bit 5	Bit 4	Bit 3	Bit 2	Bit 1	Bit 0	Description	Output
D23	D22	D21	D20	D19	D18	D17	D16	LEDs 16 to 23, red	Byte 0
D23	D22	D21	D20	D19	D18	D17	D16	LEDs 16 to 23, green	Byte 1
D23	D22	D21	D20	D19	D18	D17	D16	LEDs 16 to 23, blue	Byte 2

Bit 7	Bit 6	Bit 5	Bit 4	Bit 3	Bit 2	Bit 1	Bit 0	Description	Output
D31	D30	D29	D28	D27	D26	D25	D24	LEDs 24 to 31, red	Byte 3
D31	D30	D29	D28	D27	D26	D25	D24	LEDs 24 to 31, green	Byte 4
D31	D30	D29	D28	D27	D26	D25	D24	LEDs 24 to 31, blue	Byte 5

D = LED

Digital outputs, slot 4

Bit 7	Bit 6	Bit 5	Bit 4	Bit 3	Bit 2	Bit 1	Bit 0	Description	Input
DO23	DO22	DO21	DO20	DO19	DO18	DO17	DO16	Output 16 to 23	Byte 0
DO31	DO30	DO29	DO28	DO27	DO26	DO25	DO24	Output 24 to 31	Byte 1

DO = Digital output

9.9 KP32F – Sensor evaluation of the fail-safe channels

Note

For digital inputs that are reserved with a fail-safe channel, the process image described in the chapter "KP32F - Bit assignment in the process image (Page 119)" is **not** used.

The fail-safe channels occupy the following address areas in the process image of the fail-safe controller:

Input area	Output area
x + 0 to x + 4	x + 0 to x + 3

x The start address for the input and output range.

The address was entered on the "Addresses" tab in the HW Config in the object properties of the module "KP32F, slot 5".

The first byte in the process image describes the switch state of the connected sensors or a connected EMERGENCY STOP button. The setting is described in the section "Setting the fail-safe properties (Page 89)".

Note

The unused bits in the byte 0 are always "0".

The following evaluations are possible:

- FI.0.FI.1 disabled, FI.2.FI.3 disabled

Slot 5 was not set. No evaluation occurs.

SIL2				SIL3			
Bit 7	Bit 6	Bit 5	Bit 4	Bit 3	Bit 2	Bit 1	Bit 0

First byte

- FI.0.FI.1 1oo1, FI.2.FI.3 disabled

Slot 5 parameters were set to "FI.0.FI .1 1oo1, FI.2.FI .3 disabled". The connected sensors are evaluated.

SIL2				SIL3			
Bit 7	Bit 6	Bit 5	Bit 4	Bit 3	Bit 2	Bit 1	Bit 0

First byte

Bits 4 and 5 determine if the respective sensor contact is open or closed. The bits may take on the following values:

- 0 = Open sensor contact
- 1 = sensor contact closed

- FI.0.FI.1 1oo2, FI.2.FI.3 disabled

Slot 5 parameters were set to "FI.0.FI.1 1oo2, FI.2.FI.3 disabled". The EMERGENCY STOP button is evaluated.

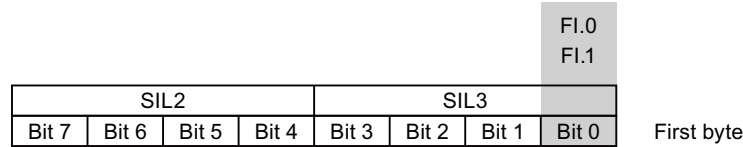

Bit 0 determines whether or not the EMERGENCY STOP button was pressed. The bit can take on the following values:

- 0 = EMERGENCY STOP button pressed or error
- 1 = EMERGENCY STOP button **not** pressed

- FI.0.FI.1 1oo2, FI.2.FI.3 1oo2

Slot 5 parameters were set to "FI.0.FI.1 1oo2, FI.2.FI.3 1oo2". The EMERGENCY STOP buttons are evaluated.

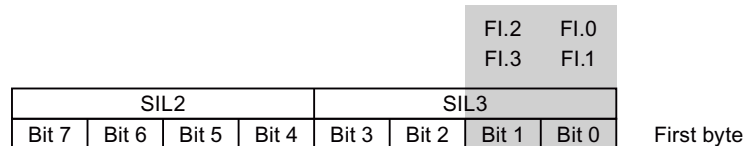

Bits 0 and 1 determine whether or not the EMERGENCY STOP button was pressed. The bit can take on the following values:

- 0 = EMERGENCY STOP button pressed or error
- 1 = EMERGENCY STOP button **not** pressed

- FI.0.FI.1 1oo2, FI.2.FI.3 1oo1

Slot 5 parameters were set to "FI.0.FI.1 1oo2, FI.2.FI.3 1oo1". The EMERGENCY STOP button and the connected sensors are evaluated.

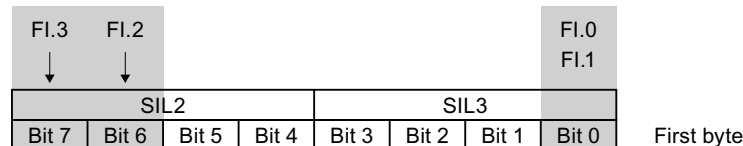

Bit 0 determines whether or not the EMERGENCY STOP button was pressed. The bit can take on the following values:

- 0 = EMERGENCY STOP button pressed or error
- 1 = EMERGENCY STOP button **not** pressed

Bits 6 and 7 determine if the respective sensor contact is open or closed. The bits may take on the following values:

- 0 = Open sensor contact
- 1 = sensor contact closed

9.9 KP32F – Sensor evaluation of the fail-safe channels

- FI.0.FI.1 1oo1, FI.2.FI.3 1oo1

Slot 5 parameters were set to "FI.0.FI .1 1oo1, FI.2.FI .3 1oo1". The connected sensors are evaluated.

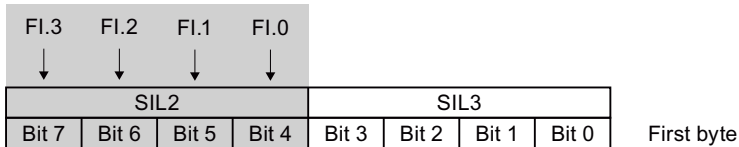

Bits 4 to 7 determine if the associated sensor contact is open or closed. The bits may take on the following values:

- 0 = Open sensor contact
- 1 = sensor contact closed

Appendix

A.1 ESD guideline

What does ESD mean?



An electronic module is equipped with highly integrated electronic components. Due to their design, electronic components are highly sensitive to overvoltage and thus to the discharge of static electricity. Such electronic components are labeled as electrostatic sensitive devices (ESD).

The following abbreviations are commonly used for electrostatic sensitive devices:

- ESD – Electrostatic Sensitive Device
- ESD – Electrostatic Sensitive Device (internationally recognized term)

Electrostatic charge

CAUTION

Electrostatic charge

ESDs may be destroyed by voltages far below the level perceived by human beings. If you are not discharged electrostatically, the voltage that you transfer when touching a component or the contact points of a module can already cause damage.

The damage to an ESD caused by overvoltage is usually not recognized immediately. The damage only becomes apparent after a long period of operation.

Discharge any electrostatic charge of your body before you touch the ESD.

Anyone who is not connected conductively to their surroundings is subject to electrostatic charge.

The following diagram shows the maximum voltage values to which a person can be charged electrostatically. The values depend on the material and humidity. The shown values are in conformity with the specifications of EN 61000-4-2.

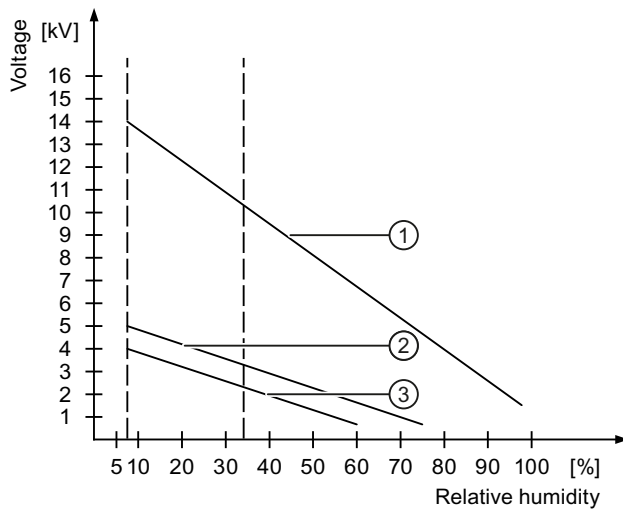

- ① Synthetic materials
- ② Wool
- ③ Antistatic materials such as wood or concrete

Protective measures against discharge of static electricity

CAUTION

Grounding measures

There is no equipotential bonding without grounding. An electrostatic charge is not discharged and may damage the ESD.

When working with electrostatic sensitive devices, make sure that the person and the workplace are properly grounded.

Note the following:

- Only touch the ESD if it is absolutely necessary.
- When you touch ESD modules, avoid touching the pins or the PCB tracks.
This precaution reduces the risk of damaging an ESD.
- Discharge electrostatic electricity from your body if you are performing measurements on an ESD.
To do so, touch a grounded metal object before you carry out the measurement.
- Always use grounded measuring instruments.

List of abbreviations

CPU	Central Processing Unit
DC	Direct Current
DIL	Dual-in-Line
DP	Distributed I/O
ESD	Electrostatic Discharge, the components and modules endangered by such
EMC	Electromagnetic Compatibility
EN	European standard
ESD	Electrostatic Sensitive Device
F-CPU	Fail-safe Central Processing Unit
GND	Ground
GSD	Device master file
HF	High Frequency
HMI	Human Machine Interface
IEC	International Electronically Commission
IRT	Isochronous Real-Time
LED	Light Emitting Diode
MTTR	Meantime to Restoration
MRP	Media Redundancy Protocol
MS	Microsoft
PELV	Protective Extra Low Voltage
PFD	Probability of a dangerous Failure on Demand
PFH	Probability of a dangerous Failure per Hour
PL	Performance Level
RSTP	Rapid Spanning Tree Protocol
SELV	Safety Extra Low Voltage
SIL	Safety Integrity Level
TIA	Totally Integrated Automation
UL	Underwriter's Laboratory

Glossary

Automation system

is a controller of the SIMATIC S7 series such as a SIMATIC S7-1200.

Controller

General term for devices and systems with which the HMI device communicates, e.g. SIMATIC S7.

Diagnostics

Diagnostics enable you to determine if the signals are being correctly registered in the fail-safe HMI device.

EMC

Electromagnetic compatibility (EMC) refers to a state in which technical equipment does not disturb other equipment with unwanted electrical or electromagnetic effects. Electromagnetic compatibility deals with technical and regulatory questions of undesired, mutual influence in electrical engineering.

Failsafe

Capability of a technical system to remain in a safe state or switch to another safe state immediately in the event of a failure or fault.

Fail-safe system, F system

A fail-safe system is used to control production processes in which immediate shutdown results in a safe system status. This means that a fail-safe systems control processes that do not present a danger to people or the environment if a direct shutdown of the plant occurs.

Fail-safe systems are used in plants with high safety requirements.

GSD

The GSD file contains all the properties of a DP slave or IO device. STEP 7 requires a GSD file for each DP slave and for each IO device to allow the DP slave or IO device to be selected in the module catalog of HW Config.

Passivation

If the F-I/O detects a fault/error, it switches the affected channel or all its channels to the safe state. In other words, channels of this F-I/O are passivated. The F-I/O reports the detected error to CPU via the slave diagnostics. With an F-I/O with inputs, passivation is performed by the the F system by making available substitute values (0) to the safety program instead of the process values queued at the fail-safe inputs. With an F-I/O with outputs, passivation is performed by the the F system by sending substitute values (0) to the fail-safe outputs instead of the output values provided by from the safety program.

PROFINET

Within the framework of Totally Integrated Automation (TIA), PROFINET represents an enhancement of the following bus systems:

- PROFIBUS DP as well-established field bus
- Industrial Ethernet as the communication bus for the cell level

The experience gained from both systems has been and continues to be integrated in PROFINET. PROFINET as an Ethernet-based automation standard from PROFIBUS International (PROFIBUS Nutzerorganisation e.V.) defines a vendor-independent communication and engineering model.

PROFINET IO controller

Device used to address the connected IO devices. That is: The IO controller exchanges input and output signals with assigned field devices. The IO controller is often the controller on which the automation program runs.

PROFINET IO device

A PROFINET IO device is a decentralized field device that is assigned to one of the IO controllers (e.g., remote IO, valve terminals, frequency converters, switches)

PROFINET IO

As part of PROFINET, PROFINET IO is a communication concept that is used to implement modular, distributed applications.

PROFINET IO allows you to create automation solutions of the type with which you are familiar from PROFIBUS.

PROFINET IO is implemented by the PROFINET standard for automation devices on the one hand, and on the other hand by the STEP 7 engineering tool.

This means that you have the same application view in STEP 7 regardless of whether you configure PROFINET devices or PROFIBUS devices. Programming your user program is essentially the same for PROFINET IO and PROFIBUS DP if you use the extended blocks and system status lists for PROFINET IO.

PROFIsafe

Fail-safe bus profile of PROFINET for communication between the safety program and the F-I/O in an F system.

PROFIsafe address

Every F-I/O has a PROFIsafe address. This address is used to receive safety frames from the fail-safe CPU or send safety frames to the fail-safe CPU.

Proof-test interval

The proof-test interval is the time period after which a component must be put into fail-safe state. That is, it is replaced by an unused component or it is proven to be completely fault-free.

Reintegration

Reintegration of the fail-safe I/O is required after troubleshooting. Reintegration (switching from substitute values to process data) takes place either automatically or following user acknowledgment.

For an F-I/O module with inputs, the process data queued at the failsafe inputs are made available again to the safety program after reintegration. For an F-I/O module with outputs, the output values for fail-safe outputs are sent again by the system to the fail-safe outputs.

Safe state

State of a unit in which safety is assured. In other words, the risk is acceptably low because it has been established that safety-related malfunctions do not occur or because of the safety measures taken to prevent possible safety-related malfunctions.

The basic principle of the safety concept in a fail-safe system is the existence of a safe state for all process variables.

Safety class

Safety integrity level according to IEC 61508 and prEN 50129. The higher the safety integrity level, the sharper the measures taken to avoid systematic errors and to control systematic errors and random hardware failures.

Safety function

Safety function is a mechanism integrated in fail-safe CPUs and I/Os, enabling them to be used in fail-safe systems. According to IEC 61508: A safety function is implemented by a safety system to ensure that the system is kept in a safe state or brought into a safe state in the event of a particular fault (user safety function).

Safety mode

Operating mode of the HMI device in which safety-related communication can be performed via safety frames.

safety-related communication

Communication used to exchange fail-safe data.

Sensor evaluation

Two types of sensor evaluation:

- 1oo1 evaluation

Sensor signal is read once.

- 1oo2 evaluation

The sensor signal is read twice by the same F-I/O and compared internally.

Standard mode

Operating mode of an HMI device in which only standard communication is possible and safety-related communication cannot be performed via safety frames.

STEP 7

Programming software SIMATIC S7, SIMATIC C7 and SIMATIC WinAC controllers.

Index

1

- 1oo1 evaluation
 - encoder, 118
 - Sensor, 122, 123, 124
- 1oo1-parameterization, 22
- 1oo2 evaluation
 - EMERGENCY-STOP button, 118, 123
- 1oo2 parameter assignment, 22

A

- Address range, 117, 122
- Ambient condition
 - Climatic, 36
 - Mechanical, 36
- Ambient temperature
 - Impermissible, 37
- Approval
 - Australia, 26
 - FM, 26
 - Korea, 26
 - New Zealand, 26
 - Protection against explosion, 25
 - UL, 26
- Assign parameters
 - Slot 0, 75, 85
 - Slot 1, 76, 86
 - Slot 2, 78, 86
 - Slot 3, 87
 - Slot 4, 88
 - Slot 5, 89
- Automation system, 20

C

- Cable
 - Request, 45
- Calculating
 - Response time, 101
- CE mark, 25
- Channel
 - Fail-safe, 117, 122
- Charge
 - Electrostatic, 125

- Check list
 - Assign parameters for KP32F, 71
 - KP8 parameter assignment, 71
 - KP8F parameter assignment, 71
 - Mounting and connecting, 47
 - Planning the operation, 33
- Clearance, 40
- Climatic
 - Transport conditions, 33
- Communication error, 97
- Condensation, 34
- Conductor cross-section, 53
 - Equipotential bonding, 50
- Configuration diagram
 - Connecting the controller, 62
 - Connecting the power supply, 52
- Configuration error, 97
- Configuration example, 21
- Configuring software, 20
- connecting
 - Connection sequence, 48
 - EMERGENCY-STOP button, 56, 59
 - Equipotential bonding, 50
 - HMI device, 48
 - non fail-safe input/output, 54
 - Plug connector, 53
 - Sensor, 57, 60
- Connecting
 - Controller, 62
- Connecting the connector, 53
- Connecting the controller
 - Configuration diagram, 62
- Connection
 - 1oo1, 57, 60
 - 1oo2, 56, 59
 - EMERGENCY STOP, 55, 58
- Connection diagram
 - Functional ground, 51
- Connection sequence, 48
- Contact person, 6
- Controller, 19
 - Input, 116, 119
 - Output, 116, 120
- Convention
 - Style, 5
 - Term, 5

D

- Degree of protection, 38, 41
- Design examination certificate, 29
- Diagnostic function, 22
- Diagnostics, 97
 - Reading, 98
- Diagnostics function, 97
 - Reading, 98
- Dialog
 - Properties – F-DI, 89
- Digital input
 - Slot 2, 119
 - Slot 3, 119
- digital input/output, 107
- Digital output
 - Slot 4, 121
- DIP switch, 92
- Display element, 66
- Disposal, 6
- Documents
 - SIMATIC complete, 6

E

- EC Declaration of Conformity, 25
- Electrical potential difference, 50
- Electrostatic charge, 125
- EMERGENCY STOP connection, 55, 58
- EMERGENCY-STOP button
 - Bit assignment, 118, 123
 - connect fail-safe, 56, 59
 - Response to, 95
- Emission, 27
- encoder
 - Bit assignment, 118
- Equipotential bonding
 - connecting, 50
 - Requirements, 50

F

- fail-safe channel, 117, 122
- Fail-safe mode, 95
 - Technical specifications, 111, 112
- Fail-safe operation, 22
- Fault detection, 43, 45
- Functional ground
 - Cable, 51
 - Connection diagram, 51

G

- GSD, 71

H

- Hardware update, 71
- HMI device
 - connecting, 48
 - EMC-compliant mounting, 30
 - mounting, 38, 48
 - Mounting position, 37
 - Passivation, 97
 - Serious error, 98
 - Switching off, 63
 - Switching on, 63
 - Testing, 63
 - with Ex approval, 28
- HW Config, 73

I

- Identification
 - CE, 25
- Illustration, 5
- Industry Portal, 6
- Input area
 - Slot 1, 119
 - Slot 2, 119
- Input unit
 - 1oo1 mode, 109
 - 1oo2 mode, 110
- Input/output
 - non fail-safe, 54
- Input/output device
 - External, 18
- Installation cut-out, 39
 - Dimensions, 39
- Installation location, 38
- insulation resistance, 41
- Interference
 - Pulse-shaped, 30
 - Sinusoidal, 31
- IRT, 94

K

- Key
 - Labeling, 68
- Knowledge
 - Required, 3

KP32F
Main dimensions, 106
Reintegration, 97

KP8
Main dimensions, 105

KP8F
Main dimensions, 105
Reintegration, 97

L

Labeling
Key, 68

Labeling strips, 69

M

Main dimensions
KP32F, 106
KP8, 105
KP8F, 105

Maintenance, 103

Maintenance personnel, 3

Material thickness, 41

Mechanical

Transport conditions, 33

Module diagnostics, 98

moisture protection, 41

mounting

EMC-compliant, 30

HMI device, 38, 48

Mounting clamp, 38

Mounting Depth, 40

Mounting position

HMI device, 37

MRP, 94

MTTR, 111, 112

N

Notice of protected rights, 4

O

Office location, 6

Operating

Safety, 24

Operating instructions

Scope, 3

Operation

In industry, 27

In potentially explosive atmospheres, 28

In residential areas, 27

With protective measures, 35

Operation enabled

Dual-channel, 22

Fail-safe, 95

Single-channel, 22

Operator control element, 65

Output area

Slot 1, 120

Slot 2, 121

P

Passivation, 97

Determine, 97

Performance Characteristic

KP32F, 19

KP8, 18

KP8F, 18

PFD, 111, 112

PFH, 111, 112

Pin assignment

Connector X60, 114

Connector X61, 114

RJ45, 115

X60, 112, 113

Potentially explosive atmosphere, 28

Power supply, 107

Conductor cross-section, 53

Configuration diagram, 52

connecting, 53

Connecting the connector, 53

Prescribed usage, 24

Process image, 117, 122

PROFIsafe, 20

PROFIsafe target address, 92

Proof-test interval, 43, 44

Protected trademark, 4

Protection against explosion, 25

Protection against ingress of solid foreign bodies, 41

Protection class

HMI device, 41

Protective measure

Static electricity, 126

Protocol, 20

R

Radio interference, 27

Reading
 Diagnostics function, 98
Recycling, 6
Registered trademark, 4
Reintegration, 97
Request
 Cable, 45
Response time, 101
 Influencing, 100

S

Safety function, 95
Scope
 Operating instructions, 3
Scope of delivery, 11, 47
Sensor
 Bit assignment, 122, 123, 124
 Response to, 95
Sensor connection, 57, 60
Serious error, 98
Service, 6
SFB 52, 98
SFB 54, 98
Shock, 35
Signal duration, 43, 45
SIMATIC S7, 19
Slot 0
 Assign parameters, 75
Slot 1
 Assign parameters, 76
Slot 2
 Assign parameters, 78
Slot 3
 Assign parameters, 87
Slot 4
 Assign parameters, 88
Slot 5
 Assign parameters, 89
Static electricity
 Protective measures, 126
STEP 7
 HW Config, 73
Support
 Technical, 6
Support request, 6
Switching cabinet
 Working on, 23
Switching off
 HMI device, 63
Switching on
 HMI device, 63

T

Technical specifications
 Connector X60, 114
 Connector X61, 114
 Fail-safe mode, 111, 112
 KP32F, 107, 108
 KP8, 107
 KP8F, 108
 Power supply, 107
 RJ45, 115
 Weight, 107
 X60, 112, 113
Technical support, 6
Technical Support, 6
Test
 Climatic conditions, 36
 Mechanical conditions, 36
Testing
 HMI device, 63
Trademark, 4
Training center, 6
Transport conditions, 33
Transport damage, 47
Type of fixation, 38

U

Usage
 Prescribed usage, 24

V

Vibration, 35

W

Weight, 107

Z

Zones 2 and 22
 Operating conditions, 29
 Potentially explosive atmosphere, 28