

SIEMENS

SIMATIC Sensors

RFID systems RF182C communication module

Operating Instructions

Introduction	1
Description	2
Mounting	3
Connecting	4
Parameterizing	5
Communication interface	6
Maintenance and Service	7
Diagnostics	8
Error messages	9
Examples/applications	10
Technical data	11
Dimension drawings	12
Connecting cable to the reader/SLG	13
Ordering data	14
Command and acknowledgement telegrams	A
Addressing of the RFID tags	B
Transfer scheme for hexadecimal tag data via XML	C
Service & support	D

Legal information

Warning notice system

This manual contains notices you have to observe in order to ensure your personal safety, as well as to prevent damage to property. The notices referring to your personal safety are highlighted in the manual by a safety alert symbol, notices referring only to property damage have no safety alert symbol. These notices shown below are graded according to the degree of danger.

⚠ DANGER
indicates that death or severe personal injury will result if proper precautions are not taken.
⚠ WARNING
indicates that death or severe personal injury may result if proper precautions are not taken.
⚠ CAUTION
with a safety alert symbol, indicates that minor personal injury can result if proper precautions are not taken.
CAUTION
without a safety alert symbol, indicates that property damage can result if proper precautions are not taken.
NOTICE
indicates that an unintended result or situation can occur if the corresponding information is not taken into account.

If more than one degree of danger is present, the warning notice representing the highest degree of danger will be used. A notice warning of injury to persons with a safety alert symbol may also include a warning relating to property damage.

Qualified Personnel

The product/system described in this documentation may be operated only by **personnel qualified** for the specific task in accordance with the relevant documentation for the specific task, in particular its warning notices and safety instructions. Qualified personnel are those who, based on their training and experience, are capable of identifying risks and avoiding potential hazards when working with these products/systems.

Proper use of Siemens products

Note the following:

⚠ WARNING
Siemens products may only be used for the applications described in the catalog and in the relevant technical documentation. If products and components from other manufacturers are used, these must be recommended or approved by Siemens. Proper transport, storage, installation, assembly, commissioning, operation and maintenance are required to ensure that the products operate safely and without any problems. The permissible ambient conditions must be adhered to. The information in the relevant documentation must be observed.

Trademarks

All names identified by ® are registered trademarks of the Siemens AG. The remaining trademarks in this publication may be trademarks whose use by third parties for their own purposes could violate the rights of the owner.

Disclaimer of Liability

We have reviewed the contents of this publication to ensure consistency with the hardware and software described. Since variance cannot be precluded entirely, we cannot guarantee full consistency. However, the information in this publication is reviewed regularly and any necessary corrections are included in subsequent editions.

Table of contents

1	Introduction.....	5
1.1	Introduction	5
2	Description.....	7
3	Mounting.....	13
3.1	Mounting position, mounting dimensions.....	13
3.2	Mounting the I/O module.....	14
3.3	Mounting the connection block	16
3.4	Replacing labels.....	18
3.5	Disassembling the RF182C	19
4	Connecting	21
4.1	Wiring connection block M12, 7/8".....	24
4.2	Wiring of the push-pull connection block	27
4.3	Loop-through of Ethernet and supply voltage.....	30
4.4	Wiring an RF182C to a controller with Ethernet connection.....	32
4.5	Connecting the RF182C to functional ground (PE)	33
5	Parameterizing	35
5.1	Address assignment for Ethernet.....	35
5.2	Data communication between client and RF182C.....	37
5.3	Factory setting of the RF182C.....	40
5.4	Assigning the IP address	41
5.4.1	Overview	41
5.4.2	Web server.....	41
5.4.3	Primary Setup Tool	45
5.5	Troubleshooting: Assigning the IP address	48
6	Communication interface	49
6.1	Overview of commands	49
6.2	Configuration parameters of the RF182C.....	50
6.3	Input parameters of the RF182C	52
6.4	Commands of the communication module	53
6.4.1	writeTagData.....	53
6.4.2	readTagData	54
6.4.3	initializeTag	55
6.4.4	getReaderStatus	56
6.4.5	getTagStatus.....	57
6.4.6	setAnt	58
6.4.7	heartbeat.....	59

6.5	Asynchronous message frames.....	60
6.5.1	tagPresent.....	60
6.5.2	alarm.....	61
7	Maintenance and Service	63
7.1	Replacing the RF182C communication module.....	63
7.2	Firmware update	65
7.3	Reader update	65
8	Diagnostics	67
8.1	Diagnostics using LEDs.....	67
9	Error messages	71
9.1	Response without error entry.....	71
9.2	Response with error entry.....	71
9.3	Error messages of the RF182C	72
9.4	Diagnostics via Web server.....	78
9.4.1	Saving/reading of I&M data records.....	78
9.4.2	Communication status query.....	79
9.4.3	Event and message frame overview.....	80
10	Examples/applications	81
10.1	Basic principles of socket programming, exemplary in C	81
10.1.1	Socket programming requirements.....	81
10.1.2	Basic client/server principle.....	82
10.1.3	Important basic commands	82
10.1.4	Partial programming example of a client in C/Windows operating system.....	83
10.2	RF182C user application.....	85
10.2.1	User interface layout	86
10.2.2	Extracts example code of the user application in C#.....	87
10.2.3	Functions of the RF182C applications	95
10.3	Example application for a PLC according to DIN IEC 61131.....	99
11	Technical data	101
12	Dimension drawings	103
12.1	Dimension drawing for RF182C with fixing holes	103
13	Connecting cable to the reader/SLG.....	105
13.1	Routing of standard cables	105
13.2	Self-assembled cable.....	107
14	Ordering data.....	109
A	Command and acknowledgement telegrams.....	111
B	Addressing of the RFID tags.....	123
C	Transfer scheme for hexadecimal tag data via XML	125
D	Service & support	127

Introduction

1.1 Introduction

Purpose of these operating instructions

The information provided in these Operating Instructions enables you to operate the RF182C communication module on a standard PC or a PLC.

Basic knowledge required

These operating instructions assume general knowledge of automation engineering and identification systems.

You also require basic knowledge of socket programming (TCP/IP communication via Ethernet) Socket programming depends on the programming language or the operating system used (Windows, Linux, or Unix).

Scope of this manual

The Operating Instructions apply to the RF182C communication module.

Position in the information landscape

- The manual of the relevant RFID family contains information on the readers/SLGs to be connected.
- Special information on parameterizing the RF620R/RF630R readers in conjunction with the RF182C communication module can be found in the "RF620R/RF630R parameterization manual".

Guide

These Operating Instructions describe the hardware and the communications interface of the RF182C communication module. They comprise introductory sections and reference sections (e.g. technical data).

The operating instructions include the following subject areas:

- Connection of the RF182C communication module
- Parameterization and programming of the RF182C communication module
- Diagnostics information
- Display elements of the RF182C communication module
- Information on repair and maintenance (e.g. firmware update)
- Technical data as well as dimension drawings of the RF182C communication module
- Ordering data

Recycling and disposal

- Due to its environmentally compatible equipment, the RF182C communication module can be recycled.
- Contact a certified electronic-waste disposal company to recycle and dispose of your old equipment in an environment-friendly manner.

Description

Area of application

The RF182C communication module is a module that is used for operating RFID components on a standard PC or PLC over Ethernet.

RF182C communication module

With connection block M12, 7/8"



With push-pull connection block



When using it on a standard PC, please follow the appropriate instructions for parameterization and integration in the system.

The following RFID families can be operated with the RF182C (only with normal addressing):

- RF300
- RF600
- MOBY D
- MOBY U

Features

Up to 2 readers/SLGs can be operated on the RF182C at the same time. The user can issue a command on 2 readers/SLGs simultaneously.

The tag data is accessed by means of physical addressing of the tag.

Other features

- Degree of protection IP67
- System integration with M12, 7/8" concept or with push-pull concept
- Standardized Ethernet interface
- Diagnostics support via web server
- Routing capability
- Firmware update via web server
- Support of identification and maintenance data sets (I&M): Mechanism for reading out information via the communication module, and saving system information such as function, installation date, installation location, and comments
- Module supports SNMP

Layout

The RF182C has the same enclosure as the RFID communication module ASM 456 for PROFIBUS and the RFID communication module RF180C for PROFINET.

For connecting to Ethernet, the RF182C communication module features a connection block in one of the following designs:

- Connection block in M12 design, either with
 - 5-pin 7/8" connector (standard) or
 - 4-pin 7/8" connector (option)
- Push-pull connection block design, RJ45

The following figure shows the basic design of the RF182C.

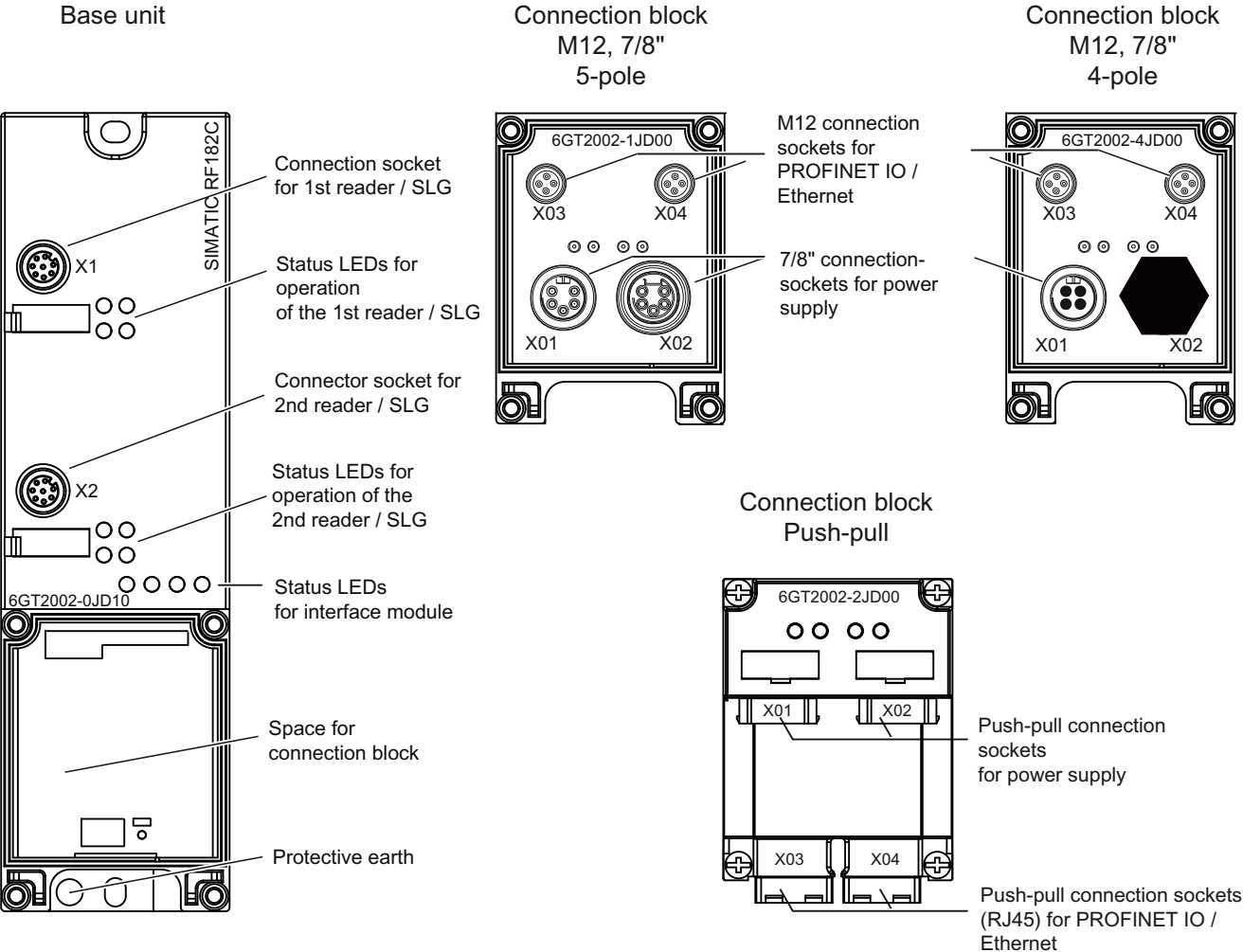

Figure 2-1 Basic design of the RF182C

Potential

Ungrounded installation of a system is possible with the RF182C. The following circuit shows the internal relationships of the reference potentials.

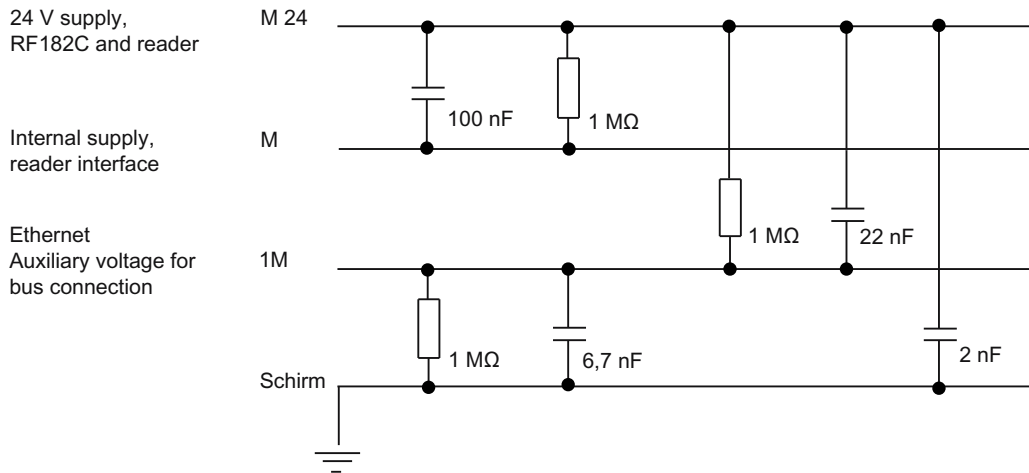

Figure 2-2 Galvanic isolation of RF182C

Integration

The following figure shows how the RF182C with connection block M12, 7/8" is integrated in an automation system. The push-pull connection block is integrated in the same manner as the connection block M12, 7/8".

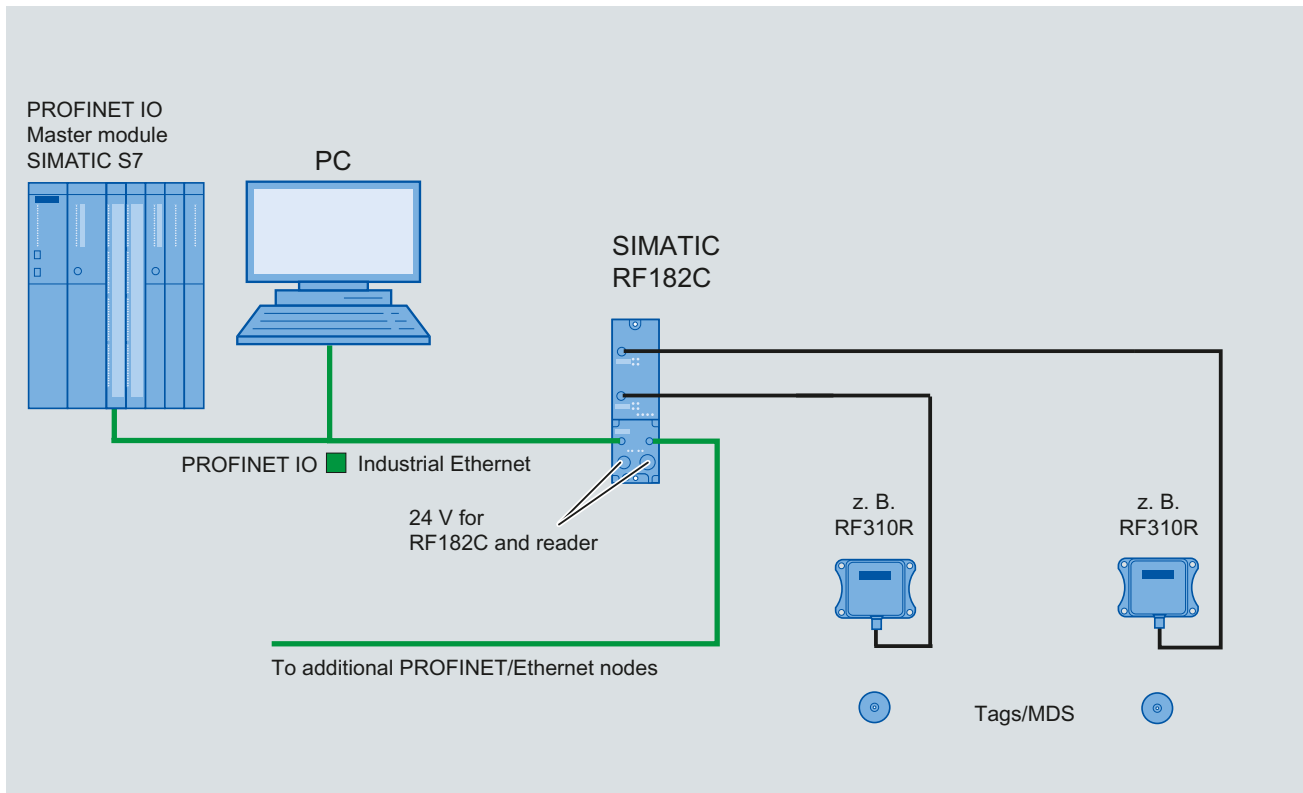

Figure 2-3 RF182C configurator with connection block M12, 7/8" □

Mounting

The RF182C communication module is designed for easy assembly.

3.1 Mounting position, mounting dimensions

Mounting position

There are no restrictions regarding the mounting position for the RF182C.

Mounting dimensions and spacing

Table 3- 1 Mounting dimensions of base module with connection block M12, 7/8" (without connector)

Designation	Dimensions
Mounting width	60 mm
Mounting height	210 mm
Mounting depth	54 mm

Table 3- 2 Mounting dimensions of base module with push-pull connection block (without connector)

Designation	Dimensions
Mounting width	60 mm
Mounting height	216 mm
Mounting depth	100 mm

3.2 Mounting the I/O module

Features

- The base unit is mounted on a stable surface

Note

Functional ground (PE)

If a grounded metal mounting surface is used, the bottom mounting screw of the RF182C module already establishes a reliable grounding connection. This eliminates the need for a separate grounding cable. If you use the fixing screw as grounding connection, the thread of the fixing screw or the contact facing of the fastening nut on the base must be unpainted. This ensures a low-resistance connection.

Requirements

Screws:

Screw type	Description
M5 cylindrical head screw to ISO 1207/ISO 1580 (DIN 84/DIN 85)	The screw should be at least 20 mm long. You will also need washers according to DIN 125.
Cylindrical head screw with M5 hexagonal recessed hole according to DIN 912	

Required tools

Medium-sized cross-head screwdriver or 8 mm socket wrench.

Procedure

Fix the base unit onto a level surface using the screws. The base unit must be screwed to the surface (3 Nm tightening torque) at both fixing points (front, top and bottom).

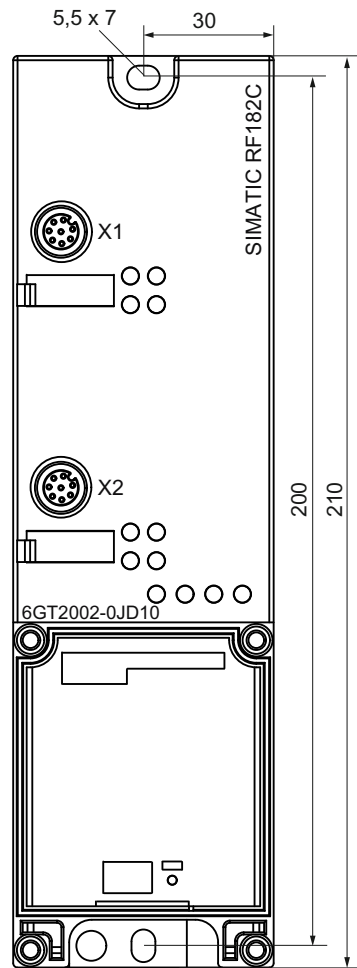

Figure 3-1 Mounting the I/O module

3.3 Mounting the connection block

Features

The connection block connects the RF182C with the Ethernet and supplies the base unit with voltage.

Requirements

The base unit is already mounted

Required tools

Cross-head screwdriver, medium.

Mounting the connection block

1. Plug the connection block into the base unit

2. Screw the connection block onto the base unit (torque 1 to 1.3 Nm) Tighten the screws evenly, working in cross-wise passes. 4 screws are already located in the connection block (see Figure).

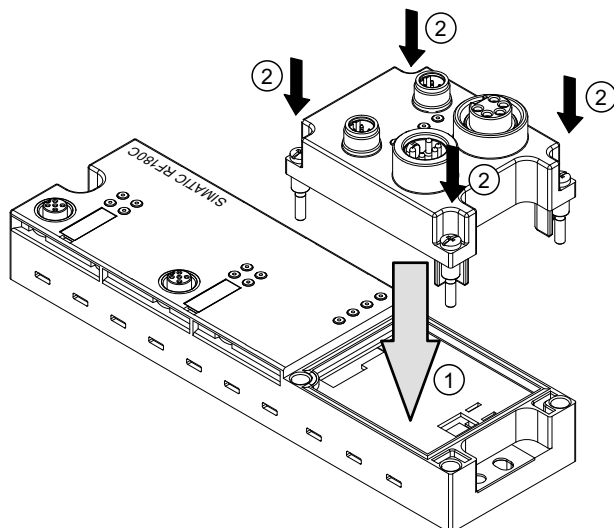

Figure 3-2 Plug the connection block M12, 7/8" onto the base unit and screw it on

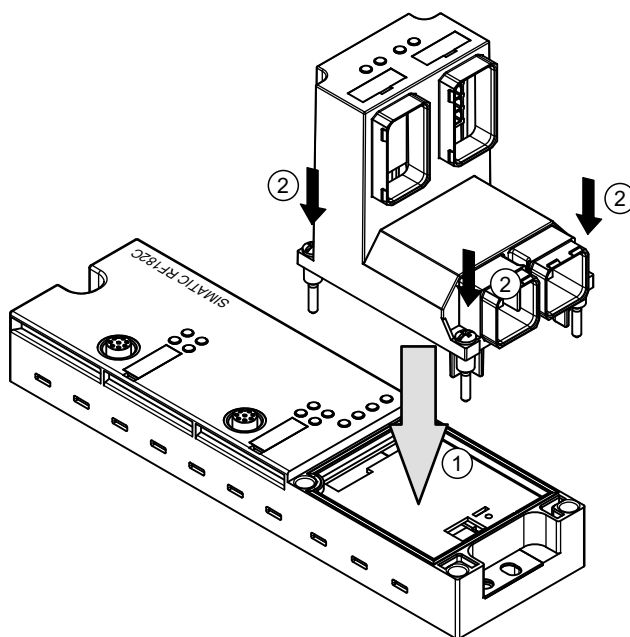

Figure 3-3 Plug the push-pull connection block onto the base unit and screw it on

Note

IP65, IP66 or IP67 degree of protection only exists when the connection block is screwed to the base unit.

3.4 Replacing labels

Features

You can use the labels to mark every channel on the base unit and the connection block. The labeling strips are supplied with clipped on label.

- 2 labels on the base module
- 1 label on connection block M12, 7/8"
- 2 labels on push-pull connection block

Requirements

If you want to replace the labels, you can reorder them. You will find the order number in section Ordering data (Page 109).

Required tools

Screwdriver, size 2.5 mm to 4 mm.

Replacing labels

1. Push the screwdriver into the small opening of the label, and then lever it out.

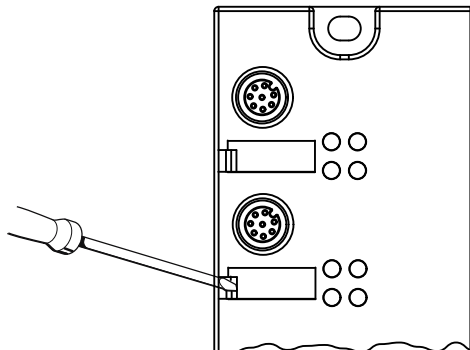

Figure 3-4 Removing labels

2. With your finger push the new label into the holder of the module.

3.5 Disassembling the RF182C

Procedure

The RF182C is wired up and operating.

1. Switch off the supply voltage for the RF182C.
2. Disconnect the wiring on the connection block.
3. Remove the 4 fixing screws from the connection block and pull the connection block off the base unit.
4. Disconnect the wiring on the base unit.
5. Remove the fixing screws from the base unit.

Note

See also section Loop-through of Ethernet and supply voltage (Page 30).

Connecting

4

Proper use

When connecting non-specified devices to the RF182C, it is possible that the connected device may be destroyed.

NOTICE

The device must **not** be connected to the public telephone network without a HUB / Switch because the voltage intervals are designed for 500 V.

Ethernet setups

Ethernet communication can be established in BUS or STAR topology. Also note the information in section Loop-through of Ethernet and supply voltage (Page 30).

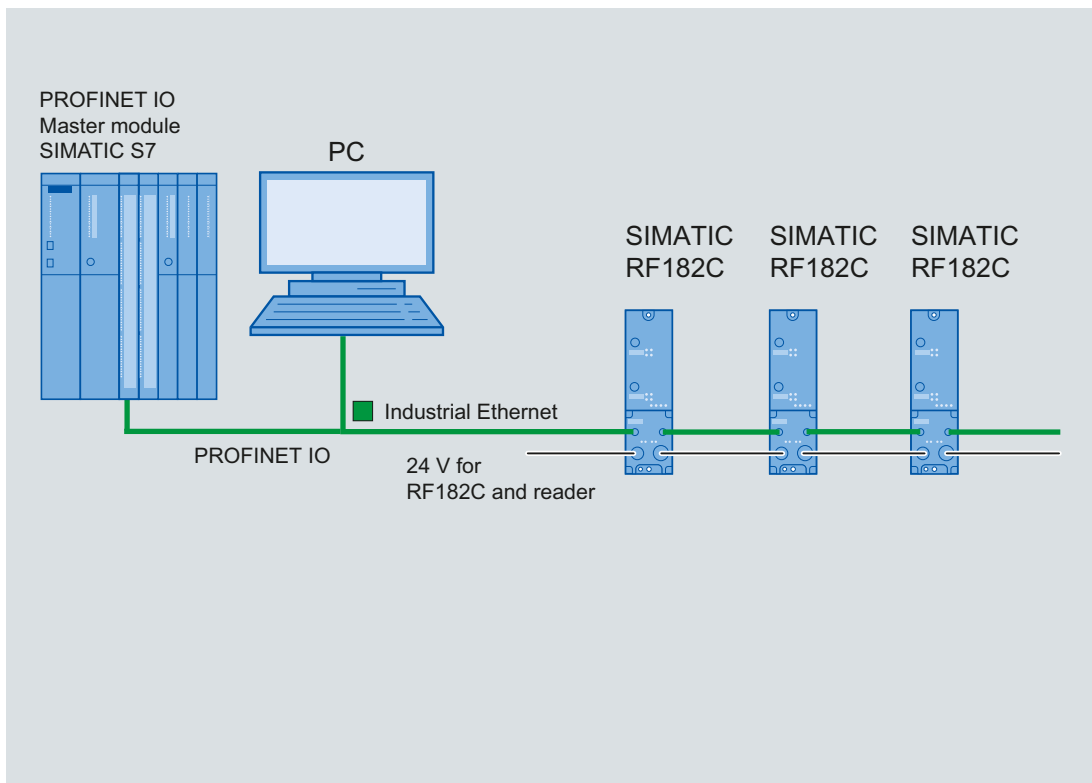

Figure 4-1 RF182C with BUS topology

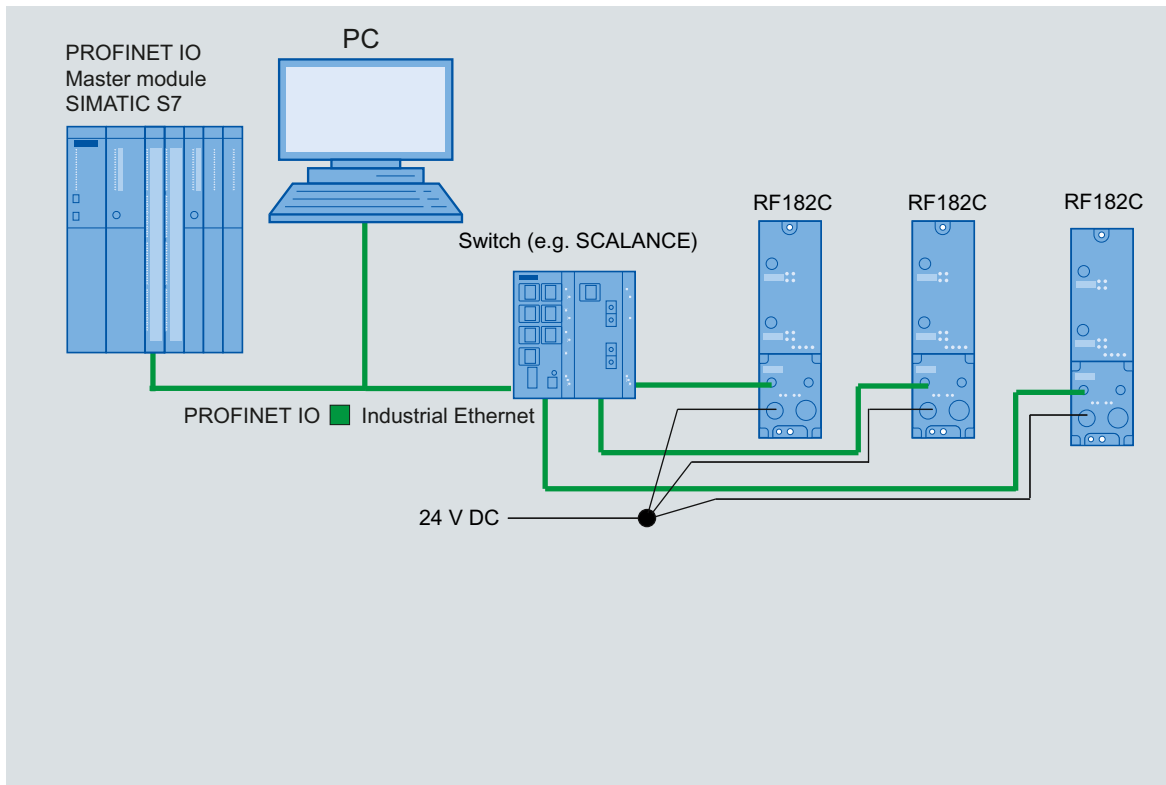

Figure 4-2 RF182C with STAR topology

Reader/SLG connection system

One reader/SLG always occupies one M12 connection socket on the RF182C. A pre-assembled cable therefore provides the optimum easy connection for the reader/SLG. The connection cable is 2 m long in the standard version.

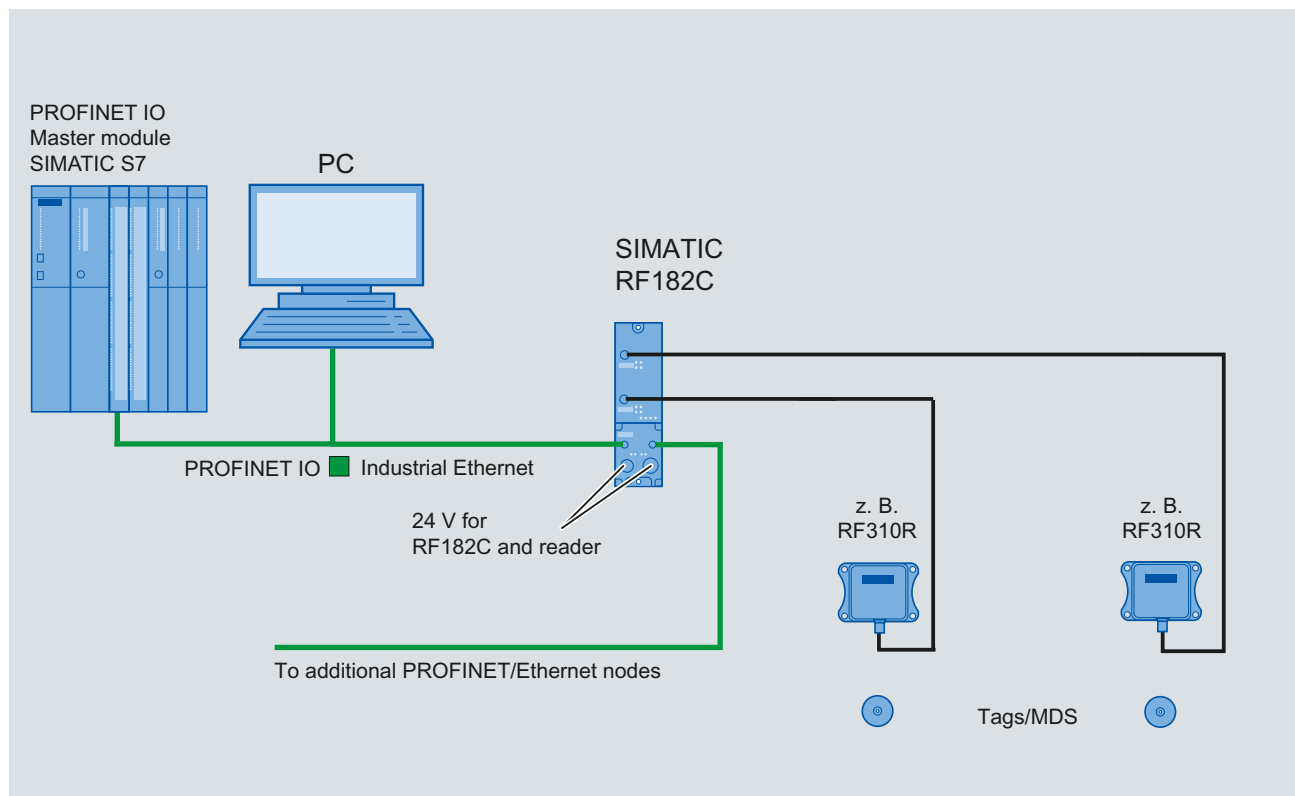

Figure 4-3 Overview of wiring

4.1 Wiring connection block M12, 7/8"

Features

- Connect the supply voltages and Ethernet to the connection block M12, 7/8":
 - M12 connection in D coding: Ethernet
 - 7/8" connection: Supply voltages
- You can loop the supply voltages and Ethernet through via the second M12 or 7/8" circular socket connectors.

Requirements

- Wire connection block M12, 7/8" when the supply voltage is switched off.

Required tools

Stripping tool, screwdriver for wiring the M12 and/or 7/8" connector if you are not using a pre-assembled cable.

Accessories required

- Pre-assembled cable with connector
- If you are not using a pre-assembled cable:
 - M12: 4-core Ethernet cable (Twisted Pair), shielded and M12 connector, 4-pole, D coding (see Table *Pin assignment of M12 connector, 4-pole, D coding (Ethernet)*)
 - 7/8": 5-core cable and 7/8" connector (see Table *Pin assignment for 7/8" connector (supply voltages)*)
- For order numbers, refer to Section *Ordering data*.

Wiring M12, 7/8" connector

The tables below contain the pin assignment for the M12 and 7/8" connectors:

Table 4- 1 Pin assignment of M12 connector, 4-pole, D coding (Ethernet)

Pin	Assignment		View of M12 connector, 4-pole, D coding (wiring side)
1	Data line TxP	Data line RxP	Infeed and loop-through of Ethernet X3, X4  Ethernet cable (Twisted Pair) Any connector can be used for infeed and looping through
2	Data line RxP	Data line TxP	
3	Data line TxN	Data line RxN	
4	Data line RxN	Data line TxN	

Table 4- 2 Pin assignment of 7/8" connector, 4-pole (supply voltages)

Pin	Assignment	View of 7/8" connector (wiring side)
1	Load voltage ground (2M)	
2	Ground for electronics/encoder supply (1M)	
3	Functional ground (PE)	
4	Electronics/encoder supply (1L+) (voltage supply for RF182C and reader/SLG)	
5	Load voltage supply (2L+) (unused on RF182C)	

Table 4- 3 Pin assignment of 7/8" connector, 4-pole (supply voltages)

Pin	Assignment	View of 7/8" connector (wiring side)
1	1L+ electronics/encoder supply (power supply for RFID 181EIP and reader/SLG)	
2	unused	
3	unused	
4	Ground for electronics/encoder supply (1M)	

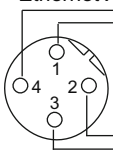
Note

When connecting the supply voltage, we recommend the cables specified in section Ordering data (Page 109) (5 x 1.5 mm² pre-assembled cable with 7/8" connectors).

If you want to assemble the cable yourself, then the conductor cross-section should be 1.5 mm².

Connecting M12, 7/8" connectors

1. Press the connector (M12 or 7/8") into the relevant round socket on the connection block. Ensure that the correct stop is provided between the connector and bush (groove and spring).
2. Use the knurled locking ring to secure the connector.

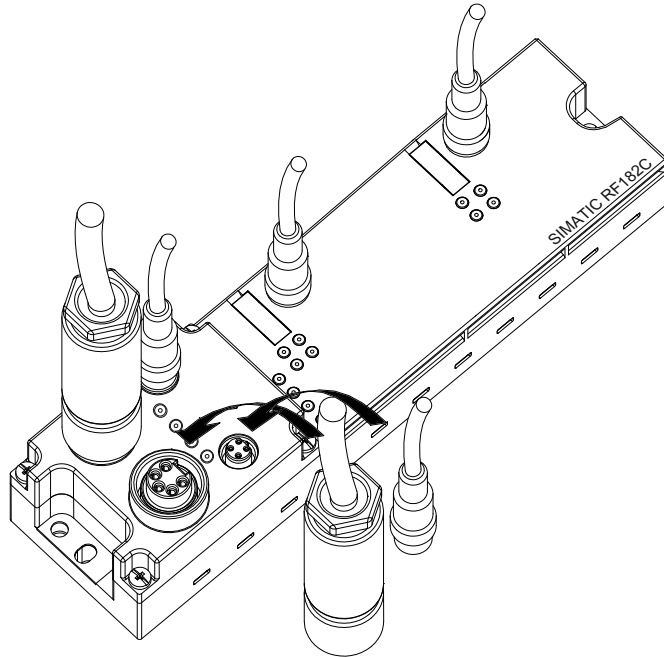

Figure 4-4 Connecting M12, 7/8" connectors

Sealing unused sockets

Always close all unused sockets using M12 or 7/8" seal caps in order to achieve the degree of protection IP65, IP66 or IP67. See section Ordering data (Page 109) for order numbers.

4.2 Wiring of the push-pull connection block

Features

- Connect the power supplies and Ethernet to the push-pull connection block:
 - Push-pull connection (RJ45), D-coded: Ethernet
 - Push-pull connection: Supply voltages
- You can loop through the supply voltages and Ethernet via the second push-pull connection.

Requirements

- Wire the push-pull connection block with the supply voltage switched off.

Required tools

- Screwdriver
- Stripping tool for wiring the push-pull cable connector if you assemble your own cables.

Accessories required

- Pre-fabricated cables with push-pull cable connector for 1L+/2L+ and RJ45. The cables are available in various lengths from appropriate manufacturers.
- If you assemble your own cables:
 - 5-core cable and push-pull cable connector for 1L+/2L+
 - 4-core, shielded cable (bus cable) and push-pull cable connector for RJ45

Note

Refer to the manufacturer's documentation if you are fabricating the cables with the push-pull cable connectors.

Wiring of push-pull connectors

The tables below contain the pin assignment for the push-pull connectors:

Table 4- 4 Pin assignment of push-pull cable connectors (RJ45)

View of push-pull cable connectors (RJ45)	Terminal	Assignment	
<p>X03 PN1</p> <p>X04 PN2</p>	X03 PN1 for infeed from Ethernet X04 PN2 for loop-through from Ethernet		
	1	Transmit Data+ TD	Receive Data+ RD
	2	Transmit Data- TD_N	Receive Data- RD_N
	3	Receive Data+ RD	Transmit Data+ TD
	4	Ground GND (RJ45)	
	5	Ground GND (RJ45)	
	6	Receive Data- RD_N	Transmit Data- TD_N
	7	Ground GND (RJ45)	
8	Ground GND (RJ45)		

Table 4- 5 Pin assignment of push-pull cable connectors (1L+ and 2L+ supply voltages)

View of push-pull cable connectors (1L+ and 2L+ supply voltages)	Terminal	Assignment	
<p>X01 DC 24V</p> <p>X02 DC 24V</p> <p>1L+</p> <p>2L+</p>	X01 DC 24 V for infeed X02 24 V DC for looping through		
	1	Electronic/encoder supply 1L+ground	
	2	Ground for electronic/encoder supply 1M	
	3	2L+ load voltage supply	
	4	Ground for load voltage supply 2M	
5	Functional ground (PE)		

Note

When connecting the power supply, we recommend the cables specified in section Ordering data (Page 109) (5 x 1.5 mm² pre-assembled with push-pull connectors).

If you want to assemble the cable yourself, then the conductor cross-section should be 1.5 mm².

A cable cross-section of 2.5 mm² is mandatory for an amperage > 8 A.

Connecting push-pull cable connectors

Plug the push-pull cable connectors for 1L+/2L+ and RJ45 into the associated sockets (see figure below). Ensure that the locking mechanism between the connector and socket is properly applied. The connectors must engage.

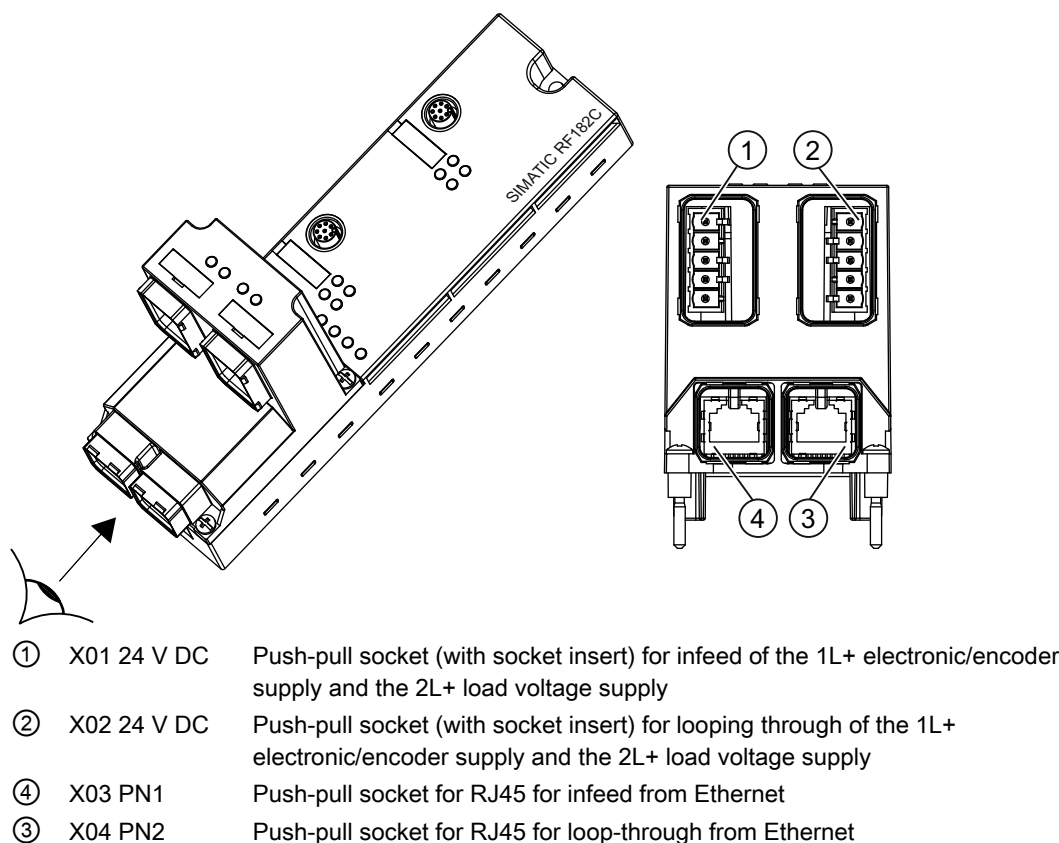

Figure 4-5 Connecting push-pull cable connectors

Sealing unused sockets

Cover all unused push-pull sockets with caps in order to achieve degree of protection IP65, IP66, or IP67. Refer to section *Ordering data* for order numbers.

4.3 Loop-through of Ethernet and supply voltage

Features

The connection block features one connector for the incoming supply and one socket for loop-through connection of the supply voltage. The connector and the socket for the supply are linked with one another internally.

Two sockets are available for the infeed and loop-through of Ethernet. The sockets are not connected to each other in the connection block. The switch in the base unit creates the logical connection.

Note

If you disassemble the connection block during operation, only the power supply will be looped through. Data communication to subsequent devices will be interrupted from this module onwards.

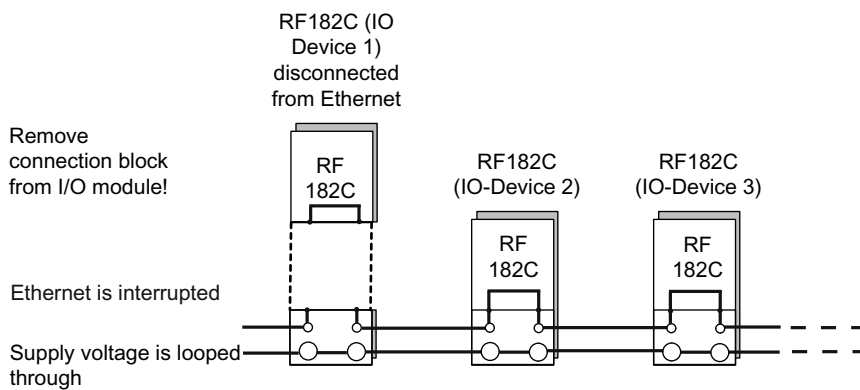

Figure 4-6 Loop-through of Ethernet and supply voltage

CAUTION

The IP65, IP66 or IP67 degree of protection is no longer guaranteed when the connection block is dismantled.

Notes for wiring

- If you are wiring your structure, then you must take into account the impact of cable length on supply voltage to the RF182C.

Example:

When using a 10 m long cable with a diameter of 1.5 mm², the voltage drop is 2.5 V with a loading of 10 A. This corresponds to 0.25 V at a 1 A load.

- The maximum infeed current for connection block M12, 7/8" is 6 A at 1L+ and 8 A at 2L+. These values must not be exceeded.
- The maximum infeed current of the push-pull connection block is 12 A for 1L+ and 2L+ at up to 40 °C and 8 A for 1L+ and 2L+ at up to 60 °C. These values must not be exceeded.
- Adhere to the current carrying capacity of the connected cables, which depends on the conductor material, the conductor cross-section and the ambient temperature.

CAUTION
If you do not observe the maximum infeed current and the cable cross-section required, this may result in the cable isolation and contacts overheating and to the device being damaged.

CAUTION
Damage
A cable cross-section of 2.5 mm ² is mandatory for an amperage > 8 A!

4.4 Wiring an RF182C to a controller with Ethernet connection

A connection from Ethernet to an M12 connection can be easily implemented.

Self-assembly of an Ethernet M12 cable

- You will need a pre-assembled PROFINET/Ethernet cable with M12 connectors at both ends twice the required length. You will also need two Ethernet connectors for self-assembly. Cut the M12 cable in the center and connect one Ethernet connector to each free cable end. This will result in two Ethernet M12 cables.
- You will need the following individual parts: Ethernet plug-in connector, M12 plug-in connector, and PROFINET/Ethernet standard cable (unassembled). The parts can be found in the ordering data. You can make up a cable to your own length requirements using these parts.

Using a cabinet bushing Ethernet M12

This connection variant must always be used when the controller electronics is installed in a cabinet. The following figure shows the connection layout.

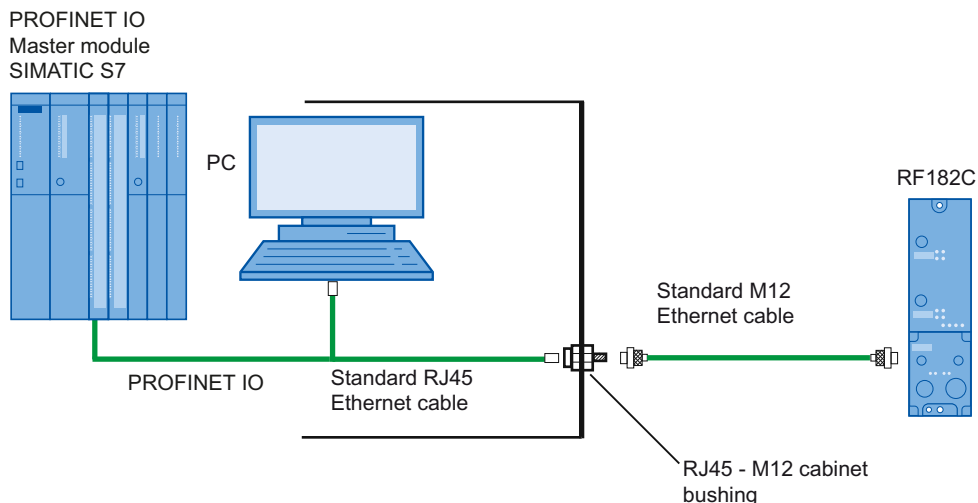

Figure 4-7 Cabinet bushing

4.5 Connecting the RF182C to functional ground (PE)

Features

- You have to connect the RF182C to the functional ground (PE). For this purpose, a grounding screw for one grounding cable is provided on the communication module.
- If a grounded metal mounting surface is used, the bottom mounting screw of the RF182C module already establishes a reliable grounding connection. This eliminates the need for a separate grounding cable.
- The connection to functional ground (PE) is also required to deflect the interference currents and for electromagnetic compatibility.

Requirements

- Always make sure there is a low-resistance connection to the functional ground (PE).
- If you use the fixing screw as grounding connection, the thread of the fixing screw or the contact facing of the fastening nut on the base must be unpainted. This ensures a low-resistance connection.

Required tools (only if grounding via the grounding cable is required).

- Screwdriver
- Stripping tool
- Crimp tool

Required accessories (only if grounding via the grounding cable is required).

- M5 x 10 grounding screw and washers
- Grounding cable (copper braided cable) with minimum cross-section of 4 mm²
- Cable lug

Connecting the RF182C to functional ground (PE)

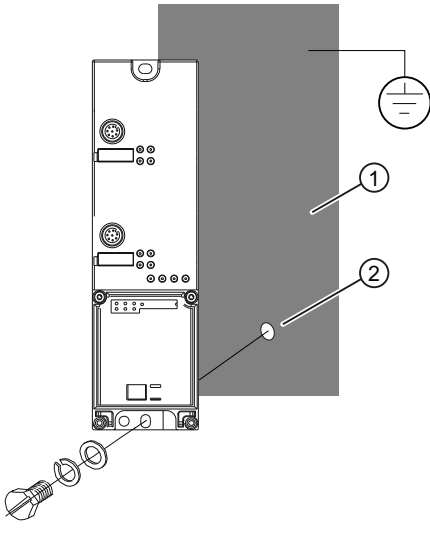
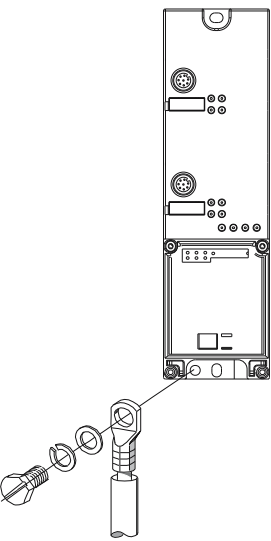
Standard grounding via the fixing screw	Optional grounding via a grounding cable
<p>1. Mount the module on the grounded, metallic base as described in section <i>Mounting the I/O module</i>.</p> <ul style="list-style-type: none">① Grounded, metallic base② Unpainted thread or nut base	<p>1. Isolate the grounding cable and secure the cable lug.</p> <p>2. Screw the cable lug on to the communication module (M5 grounding screw). The tightening torque is 3 Nm.</p>
	

Parameterizing

5.1 Address assignment for Ethernet

The reader is connected to Ethernet via the RF182C communication module. Communication between the application in the PC (client) and the reader (via the RF182C as server) only functions with a unique address assignment:

MAC-ADD

The physical address, MAC-ADD (Media Access Address), is defined by the manufacturer for each RF182C.

Example MAC-ADD: 67-89-AB-CD-EF-01

You will find the MAC-ADD printed on the side of the RF182C.

IP address

In addition, each RF182C requires a logical address, an IP address (Internet protocol), which is used to address it on the network.

An IP address may be present only once within a network. It must be parameterized in the RF182C. In the user application in the PC, the IP address is specified when establishing a connection.

The IP address always comprises 32 bits and is represented in decimal format (value range from 0 to 255). It therefore comprises a string of four numbers in ASCII format which are each separated by a point.

Example of an IP address: "157.163.170.12";

Subnet mask

The subnet mask is required to specify the network. The subnet mask is similar to the IP address. It comprises four numbers which are each separated by a point (default value: 255.255.255.0).

Example of a subnet mask "255.255.0.0"

Socket

A socket is a communication end point that is defined by an IP address and a port.

Port

A port is an access point that can be addressed by means of a specific function on the device. For the RF182C, for example, the reader is addressed through port numbers.

Note

Port assignment via web server

The assignment of the ports can be changed via the web server. If no connection could be established with the RF182C, check the port setting via the web server. The default port setting is: 10001/10002.

You can then establish a connection via the set port numbers.

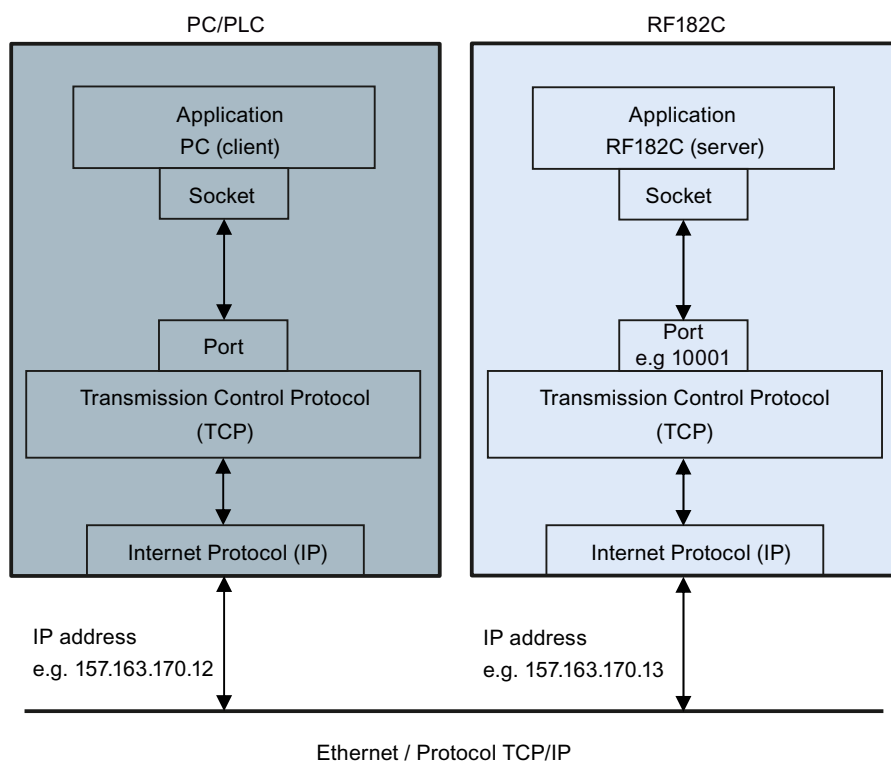

Figure 5-1 TCP/IP connection

For more detailed information on socket programming, see section Socket programming requirements (Page 81).

5.2 Data communication between client and RF182C

Basic sequence

- The module has run up and has not been parameterized yet.

Note

Connection problems?

If no connection could be established with the RF182C, check the the communication settings (IP address, port number) of the communication module via the web server (Page 41).

- Optionally, a configuration message frame (comDevSetConfig) can be sent to the RF182C to change the communication mode stored in the RF182C by default. The client that configures the RF182C first also defines the RF182C settings.

Further configurations during operation are not possible. The module must be de-energized or restarted by means of a "Reset" via the web server so that it can be reconfigured.

- If no configuration message frame is sent and the default port setting was not changed via the web server, the RF182C is operated in the default setting.

The default values are shown in the following figure:

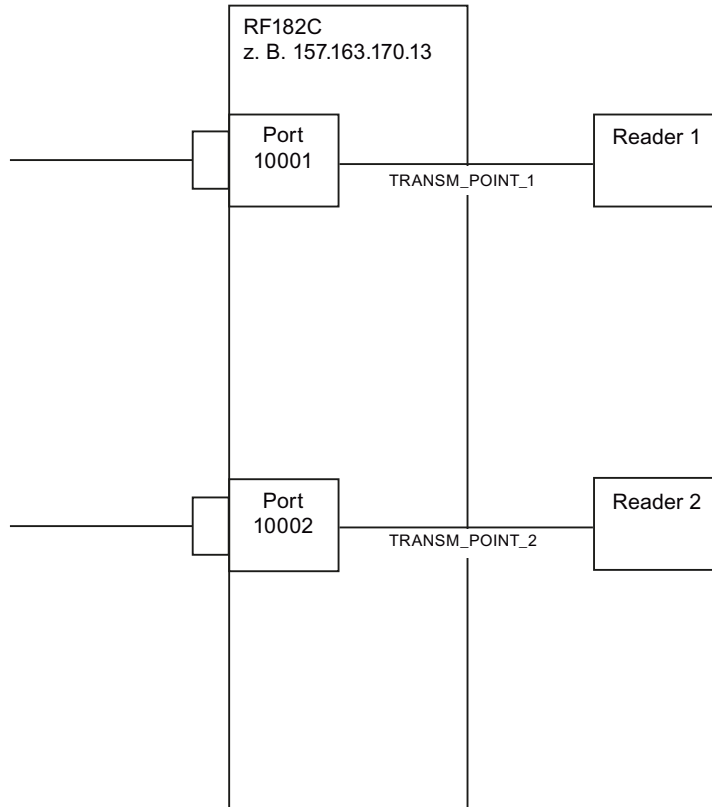

Figure 5-2 Default settings of the RF182C

Parameter	Value
Baud rate	115.2 kBaud
Port 10001	Reader 1 assignment (see chapter Web server (Page 41))
Port 10002	Reader 2 assignment (see chapter Web server (Page 41))
Asynchronous message frames (alarm/presence message) are assigned to the opened port.	
LED suppression	NONE
Mode	U/D/RF300/RF600

NOTICE

SLG D11S and D12S cannot run with the standard baud rate

Please note that the MOBY D readers SLG D11S and D12S cannot run if the standard baud rate is set.

If you want to operate these readers with the communication module, you must first parameterize the communication module and set the baud rate to 19.2 kBaud.

- The RESET message frame created by the user is sent to the corresponding reader.
- The process continues with a command message frame depending on the application.
- After longer periods without message frames (approx. 3 s), the application (client) can automatically send a heartbeat frame (line monitoring) to test the connection. The RF182C communication module then acknowledges the message frame. You yourself must ensure that the connection is monitored and define the interval after which the client should automatically send a heartbeat message frame. If, in case of an error, no response is sent in answer to the heartbeat message frame from the RF182C, the client must then initiate further actions (disconnect/connect/parameterize the reader).
- The connections (including TCP/IP) can be canceled by both sides due to the following causes:
 - Inactivity (timeout, keep-alive on TCP level)
 - Connection error
 - Disconnection request
- After disconnection by the server, the client must reconnect, send a RESET command, etc.

Data communication

The graphic below shows the principle of data communication between application (client) and RF182C:

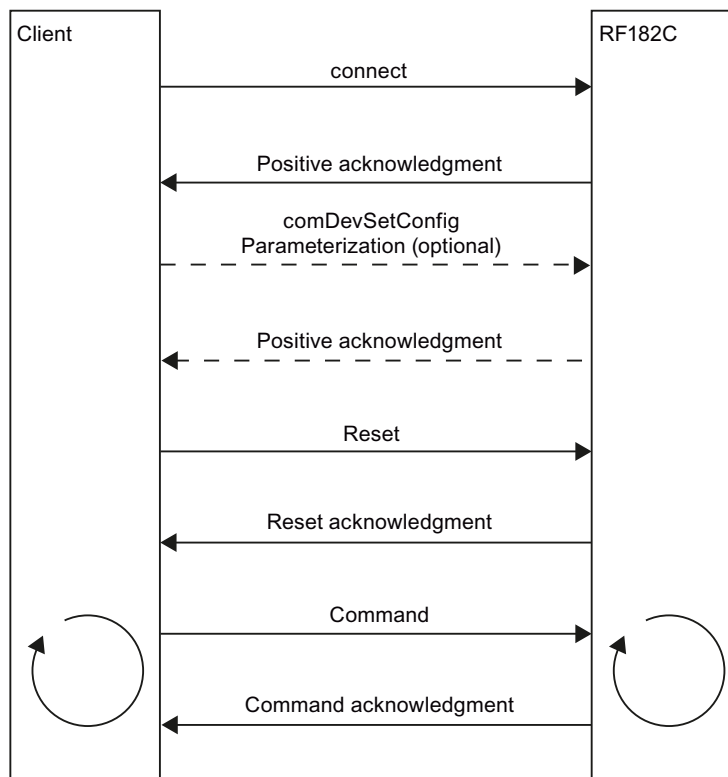

Figure 5-3 Data communication principle

5.3 Factory setting of the RF182C

Each RF182C is assigned a unique device ID (MAC address) before it leaves the factory. The communication module is addressed via the IP address during configuration and programming.

Therefore, you must first assign the IP address data (IP address and subnet mask) to the RF182C so that it can be used in the Ethernet network. An IP address can be assigned to the RF182C using the PST tool or via the web server.

Factory setting

- Default IP address setting: 192.168.0.100
- Default port setting (default:
 - 10001 Reader 1
 - 10002 Reader 2

Use the "Primary Setup Tool"

(<http://support.automation.siemens.com/WW/view/de/19440762>) software (V4-0 or higher) to assign an IP address to the communication module.

5.4 Assigning the IP address

5.4.1 Overview

There are two ways of assigning an IP address to the RF182C communication module:

- Using the "Primary Setup Tool V4-0"
- Via the web server of the communication module

Both alternative procedures are described in brief below.

5.4.2 Web server

Procedure

1. Enter the IP address of the communication module in the address field of your browser.

The web server of the communication module opens.

Note

No contact with web server RF182C

If the web server of the communication module does not open, you should make sure that all cables are correctly connected and check whether the RF182C communication module has powered up.

- 2. Check the IP address of the PC and the address of the subnet mask in the "Communication" menu, "Parameter" tab.

Note

If a connection is established, make sure that an IP address of the same subnet is assigned to the PC, laptop computer or PLC, unless a router is used. The IP address of the communication module and PC must have the same subnet mask.

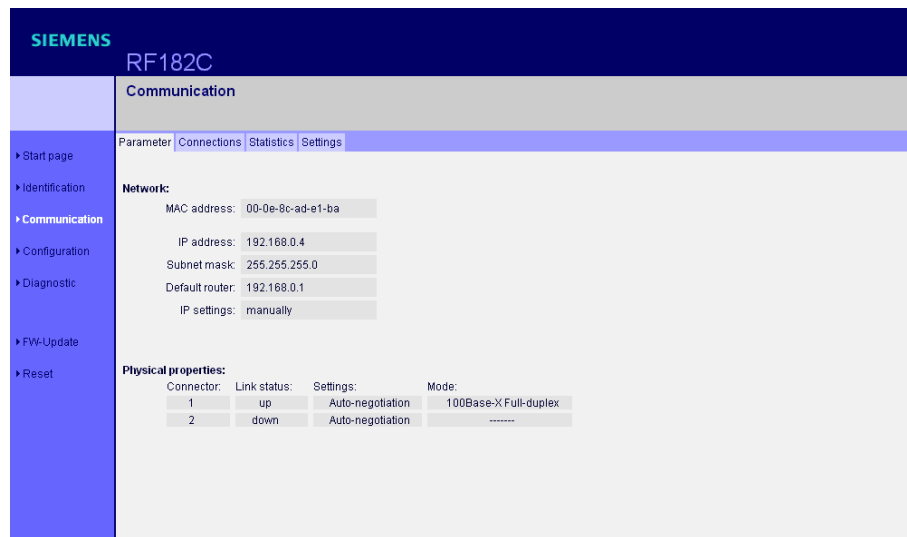

3. In the "Settings" tab you will find the settings that are currently valid on the RF182C device. Here you can change the IP address, subnet mask, default router or the port numbers of the individual readers.

NOTICE

Termination of communication

If you change the settings during ongoing operation, communication will be terminated. The application must then reconnect again with the new settings from the RF182C communication module. The same applies to the web server.

The screenshot shows the 'Settings' tab in the RF182C web interface. The left sidebar contains navigation options: Start page, Identification, Communication, Configuration, Diagnostic, FW-Update, and Reset. The main content area is divided into two sections:

- Network:** Contains three input fields: IP address (192.168.0.100), Subnet mask (255.255.255.0), and Default router (192.168.0.1). Below these is a warning: "By pressing Button, Device restarts and all Connections get lost. Further WEB-Pages can only be displayed after setting the new Address on your browser." A "transmit and restart" button is located at the bottom of this section, with the text "Inputs stored persistently on the RF182C" next to it.
- Local Port Number:** Contains two input fields: "dedicated to Reader 1" (10001) and "dedicated to Reader 2" (10002). Default values are shown in parentheses: (default: 10001) and (default: 10002). A warning states: "Port Numbers below 1024 are reserved as 'well known IP Ports' for different services and should not be used. Port numbers must be different to each other. Maximum Number: 65534." Below this is a "transmit" button with the text "Existing TCP-Connections will be interrupted by pressing button." and "Inputs stored persistently on the RF182C" next to it.

At the next startup of the communication module, the default settings are no longer active. The changed settings are now active.

Resetting to factory settings

Via the "Reset" menu, you can reset all settings to the factory settings.



1. To do this, click on the button "Reset RF182C to factory settings".

Note

Soft reset

If serious communication errors occur, you can also execute a so-called "soft reset" using the "Reset 182C" button. The communication module will then restart as if the power was turned off and back on again.

5.4.3 Primary Setup Tool

Procedure

1. Open the "Primary Setup Tool V4-0" via "Start > SIMATIC > Primary Setup Tool".
2. Select the network card of the PC in the menu under "Settings" and click the "Search" button 

A window opens that indicates that a device was found in the network.

If no RF182C communication module is shown, make sure that all cables are connected properly and check if the RF182C communication module has started.

Check the IP address of the PC and the subnet mask.

Note

If a connection is established, make sure that an IP address of the same subnet is assigned to the PC, laptop computer or PLC, unless a router is used. The IP address of the communication module and PC must have the same subnet mask.

3. Click the "+" sign next to the folder icon to display the settings of the communication module:

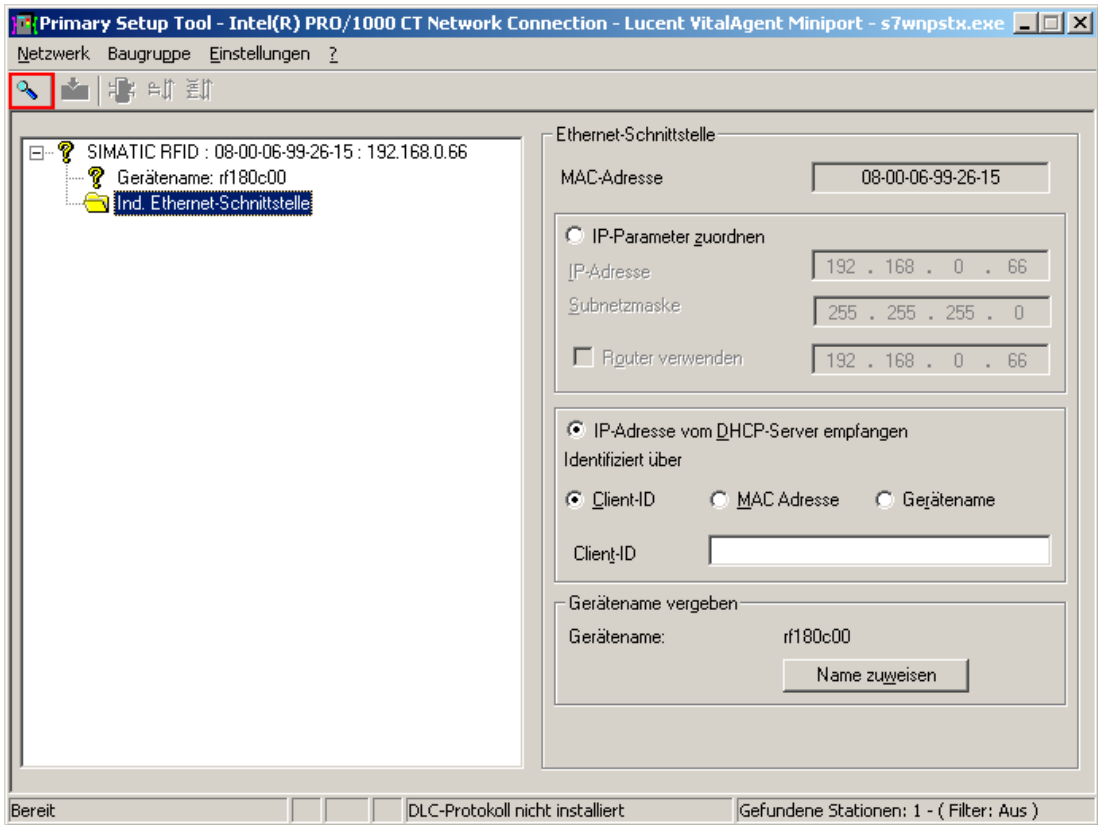



Figure 5-4 Settings of the communication module

- If you want to change the data under "Assign IP Parameters", check the adjacent option.
 - Click the button "Assign Name" to explicitly assign a name to the device, e.g. RF182C.
4. If you want to transfer the changed data to the communication module, select the higher-level folder and select "Module > Download" in the menu. Confirm the subsequent window with "Yes":

NOTICE

Waiting time

Wait until the IP address has been updated. Activate the search function by clicking the button  to view the change.

Result

You can now address the device using a browser or user program.

Note

IP address stored on connection block

The IP address is stored on the connection block. Therefore, if you replace the base module, no new IP address has to be assigned.

5.5 Troubleshooting: Assigning the IP address

If you are having problems when assigning an IP address to the SIMATIC RF182C communication module, proceed according to the checklist below:

Procedure

1. Connect the RF182C directly or via the hub/switch on your PC/notebook/PLC. Do not connect any other module/device to the network. Do **not** switch on the RF182C communication module yet.
2. Remove all other network cables from your PC/notebook and make sure that the RF182C is the only network device connected to your PC/notebook.
3. Now switch on the RF182C. Pay attention to the following LEDs:
 - The error LEDs 1 and 2 on the device should flash every 3 seconds after run up.
 - The "SF" LED should be lit.
 - The "ON" LED should be lit.
 - The "DC 24 V" LED should be lit.
 - The "BF" LED should be flashing.
 - One of the two green link LEDs should be lit (green). One or two "RxTx" LEDs should flicker depending on the communication load in the network.
4. Start the "Primary Setup Tool V4-0" software and configure the network settings if you have not already done so.
5. Click "Search"  to update the view.

The communication module should now be visible in the "Primary Setup Tool V4-0" software.
6. In the software, click the "+" sign next to the folder icon of the communication module.
7. Check "Assign IP parameter".
 - Enter a valid IP address.
8. To transfer the data, select the higher-level folder of the communication module and select "Module > Load" in the menu. Confirm the subsequent window with "Yes".
9. The IP address should be assigned to the communication module the next time the "Primary Setup Tool V4-0" inquires.

Communication interface

6.1 Overview of commands

Table 6- 1 Overview of commands

Name command	Description
comDevSetConfig	Optional: Reconfigure RF182C
reset	Reset and parameterize RF182C and reader of a channel
writeTagData	Write to tag address
readTagData	Read from tag address
initializeTag	Initialize the tag
getReaderStatus	Status of the connected readers
setAnt	Antenna on/off
heartbeat	Line monitoring
getTagStatus	Status of the tag

Note

Text file for structure of XML commands

The structure of the XML commands of this section can also be found in a text file (RF182C_XML_Commands.txt). You can find this file on the RFID CD "Software & Documentation". Follow the link "CM > ASM > RF182C > Tools".

Thus you can transfer the basic structure of the commands to your application program by means of copy and paste.

Note

Structure of the XML commands

Please note that a value must always be entered between an opening and a closing XML tag. Otherwise, the message frame will be acknowledged with the error 3550.

Example:

```
<baud rate>115200</baud rate>
```

If an XML tag pair does not contain a value, omit the complete pair.

6.2 Configuration parameters of the RF182C

The RF182C is already configured at the factory. In most cases this command can therefore be omitted in the application.

XML command

```
<command>
  <comDevSetConfig>
    <signature>RF182C</signature>
    <protocolVersion>Version</protocolVersion>
    <parameter>
      <transmissionPoint>
        <mode>Mode</mode>
        <baudrate>Baud rate</baudrate>
        <startupLedSupression>LEDSupression</startupLedSupression>
      </transmissionPoint>
    </parameter>
  </comDevSetConfig>
</command>
```

XML response

Below the XML response without error entry (for error entries, see section Error messages (Page 71)) is described:

```
<reply>
  <resultCode>Errorcode</resultCode>
  <comDevSetConfig/>
</reply>
```

Parameter

Parameter	Data type	Values
Version	ASCII	0 ... 9, A ... Z Here you must enter the following version of the protocol as string: <ul style="list-style-type: none">• V1.0
RF182C	ASCII	Here you must enter the following values: <ul style="list-style-type: none">• RF182C
Baud rate	ASCII	Here you must enter one of the following baud rates (in baud): <ul style="list-style-type: none">• 19200• 57600• 115200
LEDSuppression	ASCII	Both channels, or channel 1 or channel 2 are flashing <ul style="list-style-type: none">• NONE = run-up flashing is not suppressed by any of the two reader terminals• TRANSM_POINT_1 = run-up flashing of the err_LED at the reader 1 terminal is being suppressed• TRANSM_POINT_2 = run-up flashing of the err_LED at the reader 2 terminal is being suppressed
Mode	ASCII	U/D/RF300_DIRECT_ADDRESSING

Note

The baud rate and mode cannot be set individually; they apply for both channels.

6.3 Input parameters of the RF182C

The RESET command is always required after switching on/run-up of the module. It contains the settings for the reader connected to the RF182C.

Below the XML command for the RESET command is described:

XML command

```
<command>
  <reset>
    <param>Param</param>
  </reset>
</command>
```

XML response

Below the XML response without error entry (for error entries, see section Error messages (Page 71)) is described:

```
<reply>
  <resultCode>Errorcode</resultCode>
  <reset/>
</reply>
```

Parameter

Parameter	Data type	Values
Param	ASCII hex	00 ... FF (ASCII string of a length of 16 ASCII characters; corresponding to 8 hexadecimal numbers) e.g. 00 25 00 00 00 01 00 00 (presence activated RF300, no multitag) ¹⁾

¹⁾ The ASCII string may not contain any blank. Blanks have been inserted in the example for better readability.

A byte-by-byte breakdown of the RESET command can be found in section Command and acknowledgement telegrams (Page 111).

6.4 Commands of the communication module

6.4.1 writeTagData

With this command you can write to subareas or the complete tag insofar as there are address ranges in linear order physically on the tag.

Below the XML command for the write command (**writeTagData**) is described:

XML command

```
<command>
  <writeTagData>
    <startAddress>Address</startAddress>
    <data>Data</data>
  </writeTagData>
</command>
```

Information on the memory sizes of the tags can be found in section Addressing of the RFID tags (Page 123).

XML response

Below the XML response without error entry (for error entries, see section Error messages (Page 71)) is described:

```
<reply>
  <resultCode>Errorcode</resultCode>
  <writeTagData/>
</reply>
```

Note

The length of the data to be written is derived from the number of characters transferred in the variable <data>. Please note that in each case 2 ASCII characters of the transferred data flow are converted into a hex character on the tag in the communication module.

Parameter

Parameter	Data type	Values
Address	ASCII hex	0000 ... FFFF (4 x ASCII) <ul style="list-style-type: none"> • 0 to maximum length of the (user data - 1) • The user data is written to the tag from this start address. • Note that this parameter depends on the tag. For detailed information on the address, refer to the respective MOBY System Manual or Appendix B Addressing of the RFID tags (Page 123).
Data	ASCII hex	00...FF (ASCII string (max. 128 KB ASCII)) <ul style="list-style-type: none"> • User data to be written to the tag.

6.4.2 readTagData

With this command you can read subareas or the complete tag insofar as there are address ranges in linear order physically on the tag.

Below the XML command for the read command (**readTagData**) is described:

XML command

```
<command>
  <readTagData>
    <startAddress>Address</startAddress>
    <dataLength>Datalength</dataLength>
  </readTagData>
</command>
```

Information on the memory sizes of the tags can be found in section Addressing of the RFID tags (Page 123).

XML response

Below the XML response without error entry (for error entries, see section Error messages (Page 71)) is described:

```
<reply>
  <resultCode>Errorcode</resultCode>
  <readTagData>
    <returnValue>
      <data>Data</data>
    </returnValue>
  </readTagData>
</reply>
```

Parameter

Parameter	Data type	Values
Address	ASCII hex	0000 ... FFFF (4 x ASCII) <ul style="list-style-type: none"> 0 to maximum length of the (user data -1); the user data is read from the tag starting from this address. (Address + data length) must be smaller than the end address. Note that this parameter depends on the tag. For detailed information on the address, refer to the respective MOBY System Manual.
Datalength	ASCII hex	0000 ... FFFF (4 x ASCII) The contents of Datalength refer to the number of bytes to be read from the tag. Twice the number of characters is transmitted in the "Data" field of the XML response.
Data	ASCII hex	max. 128 KB ASCII per command

6.4.3 initializeTag

With this command the complete user memory area of the memory is deleted or overwritten with a defined value.

Below the XML command for initializing tags (**initializeTag**) is described:

XML command

```
<command>
  <initializeTag>
    <memorySize>MemorySize</memorySize>
    <defaultValue>Value</defaultValue>
  </initializeTag>
</command>
```

XML response

Below the XML response without error entry (for error entries, see section Error messages (Page 71)) is described:

```
<reply>
  <resultCode>Errorcode</resultCode>
  <initializeTag/>
</reply>
```

Parameter

Parameter	Data type	Values
MemorySize	ASCII hex	0000 ... FFFF (4 x ASCII) <ul style="list-style-type: none">• Memory size of the tag to be initialized• Note that this parameter depends on the tag. For detailed information on the memory size, refer to the respective MOBY System Manual or Appendix B Addressing of the RFID tags (Page 123).
Value	ASCII hex	00 ... FF (2 x ASCII) <ul style="list-style-type: none">• Hex value that is written to the tag.

6.4.4 getReaderStatus

The command requests diagnostic/status information from the connected reader.
 Below the XML command for the reader status (**getReaderStatus**) is described:

XML command

```
<command>
  <getReaderStatus>
    <mode>Mode</mode>
  </getReaderStatus>
</command>
```

XML response

Below the XML response without error entry (for error entries, see section Error messages (Page 71)) is described:

```
<reply>
  <resultCode>Errorcode</resultCode>
  <getReaderStatus>
    <returnValue>
      <data>Data</data>
    </returnValue>
  </getReaderStatus>
</reply>
```

Parameter

Parameter	Data type	Values
Mode	ASCII hex	00 ... FF (2 x ASCII) 01 = reader status 02 = MOBY U (SLG diagnostics I, function calls) 03 = MOBY U (SLG diagnostics II, error messages) 04 = MOBY U (SLG diagnostics III, identified MDS) 05 = MOBY U (SLG diagnostics IV, communication performance) 06 = RF300 reader diagnostics 07 = RF600 reader diagnostics
Data	ASCII hex	0000 ... FFFF (ASCII string (max. 400 x ASCII)) An acknowledgment message frame on the reader status is returned.

Reader status acknowledgement message frame

An acknowledgment message frame on the reader status is returned via the "Data" parameter. Different acknowledgment message frames are returned depending on the set "mode". All available acknowledgment message frames can be found in section Command and acknowledgement telegrams (Page 111).

6.4.5 getTagStatus

The command requests different status information on a tag in the field.
Below the XML command for the tag status (**getTagStatus**) is described:

XML command

```
<command>
  <getTagStatus>
    <mode>Mode</mode>
    <week>Week</week>
    <year>Year</year>
  </getTagStatus>
</command>
```

Note

Only with MOBY U

The italic XML tags *<week>* and *<year>* only apply for the MOBY U system. These italic tags must be omitted for other MOBY systems!

XML response

Below the XML response without error entry (for error entries, see section Error messages (Page 71)) is described:

```
<reply>
  <resultCode>Errorcode</resultCode>
  <getTagStatus>
    <returnValue>
      <data>Data</data>
    </returnValue>
  </getTagStatus>
</reply>
```

Parameter

Parameter	Data type	Values
Mode	ASCII hex	00 = MOBY U 01 = RF300: Type and write protection status 02 = RF300: Diagnostic data 03 = RF300/MOBY D: Type and write protection status for ISO tags 04 = RF600: Diagnostic data
Week	ASCII hex	00 ... FF (2 x ASCII)
Year	ASCII hex	00 ... FF (2 x ASCII)
Data	ASCII hex	0000 ... FFFF (ASCII string: max. 400 x ASCII)

Tag status acknowledgement message frame

An acknowledgment message frame on the tag status is returned via the "Data" parameter. Different acknowledgment message frames are returned depending on the set "mode". All available acknowledgment message frames can be found in section Command and acknowledgement telegrams (Page 111).

6.4.6 setAnt

Below the XML command for switching the antenna(s) on/off (**setAnt**) is described:

XML command

```
<command>  
  <setAnt>  
    <mode>Mode</mode>  
  </setAnt>  
</command>
```

XML response

Below the XML response without error entry (for error entries, see section Error messages (Page 71)) is described:

```
<reply>  
  <resultCode>Errorcode</resultCode>  
  <setAnt/>  
</reply>
```

Parameter

Parameter	Data type	Value
Mode	ASCII	D/U/RF300: 01 = switch antenna on 02 = standby; switch antenna off RF600: 00 = Antenna 1 off and Antenna 2 off 01 = Antenna 1 on and Antenna 2 off 02 = Antenna 1 off and Antenna 2 on 03 = Antenna 1 and 2 on

6.4.7 heartbeat

The heartbeat command has no parameters. Evaluation of the resultCode in the XML response shows if the connection to the communication module is still functioning properly. A missing connection between the communication module and reader causes an alarm and/or an error message.

Below the XML command for monitoring the connection (**heartbeat**) is described:

XML command

```
<command>  
  <heartbeat/>  
</command>
```

XML response

Below is the XML response without error entry

```
<reply>  
  <resultCode>0000</resultCode>  
  <heartbeat/>  
</reply>
```

See also

Error messages (Page 71)

6.5 Asynchronous message frames

6.5.1 tagPresent

The "tagPresent" notification will only be signaled if this is activated accordingly beforehand in the RESET message frame. If "tagPresence" is activated, this message frame is sent when a tag enters or exits the field of a reader.

XML message frame

```
<notification>  
  <id>Sequencenumber</id>  
  <origin>Origin</origin>  
  <tagPresent>  
    <tagCount>TagCount</tagCount>  
  </tagPresent>  
</notification>
```

Parameter

Parameter	Data type	Values
Sequence number	ASCII hex	0000 ... FFFF (4 x ASCII) The sequence number is a number that is automatically set to 0000 after switching on the RF182C. After sending a notification on the same TCP/IP channel, the sequence number is increased by 1. After FFFF, this number is also set to 0000 again.
Origin	ASCII	<ul style="list-style-type: none">• TRANSM_POINT_1 - Channel1/Reader1• TRANSM_POINT_2 - Channel2/Reader2
TagCount	ASCII hex	4 x ASCII 0000 = no tag present 0001 = there is a tag in the field of the reader 0002 = there are two tags in the field of the reader and so on, up to max. 00FF

6.5.2 alarm

If no command is pending, the RF182C communication module sends an alarm.

XML message frame

```
<alarm>
  <id>Sequencenumber</id>
  <origin>Origin</origin>
  <deviceName>Devicename</deviceName>
  <deviceTime>Time</deviceTime>
  <content>
    <code>Errorcode</code>
  </content>
</alarm>
```

Parameter

Parameter	Data type	Values
Sequence number	ASCII hex	0000 ... FFFF (4 x ASCII) The sequence number is a number that is automatically set to 0000 after switching on the RF182C. After sending an alarm on the same TCPIP channel, the sequence number is increased by 1. After FFFF, this number is also set to 0000 again.
Origin	ASCII	0 .. 9, A ... Z Source channel TRANSM_POINT_1 or TRANSM_POINT_2
DeviceName	ASCII	Name of the device (default: RF182C) The device name can be up to 256 bytes long.
Time	ASCII hex	00000000...FFFFFFFF (8 x ASCII) Time of the alarm in milliseconds This time is reset to 0000 when the RF182C is switched on. It cannot be set by the user. It is therefore a relative time
Error code	ASCII hex	0000 ... FFFF (4 x ASCII) The error code specifies the cause that triggered this alarm message frame. More information on the error codes can be found in section Error messages of the RF182C (Page 72).

7.1 Replacing the RF182C communication module

Initial situation

- The RF182C communication module is already mounted. A new RF182C communication module of the same type should be installed.
- The RF182C is wired up and operating.

Procedure

1. Remove the 4 fixing screws from the connection block and pull the connection block off the communication module.

Note

If you disassemble the connection block during operation, only the power supply will be looped through. Ethernet communication will be interrupted during module replacement from this node onwards. For more information, refer to section Loop-through of Ethernet and supply voltage (Page 30).

2. On the communication module, remove the screwed M12 plug-in connections to the readers.
3. Remove the fixing screws from the communication module and remove it.
4. Locate the new communication module and screw it down firmly.
5. Place the connection block on the new communication module and tighten the 4 fixing screws.

Result

Since the IP address of the communication module remains saved in the connection block, the new RF182C communication module is included in the data communication by the Ethernet controller.

Note

If the connection block is replaced in addition to the base unit, the RF182C may not start up automatically. In this case, proceed as follows:

What should I do if the RF182C can no longer be addressed

If the connection block is replaced in addition to the base unit, it is possible that the RF182C can no longer be addressed. This is indicated by a permanently lit or flashing BF LED.

In this case, check the network configuration. Load (e.g. using the PST tool) the required network parameters into the RF182C.

Check the diagnostic messages via the web server or check the settings of the IP address or the port number setting.

See also

Parameterizing (Page 35)

7.2 Firmware update

The firmware for the RF182C communication module can be updated via the Ethernet interface. You can start the firmware update via the web server of the communication module.

Preconditions

- The communication module is connected to the PC via Ethernet.
- Exit all applications before you start the firmware update.

Procedure

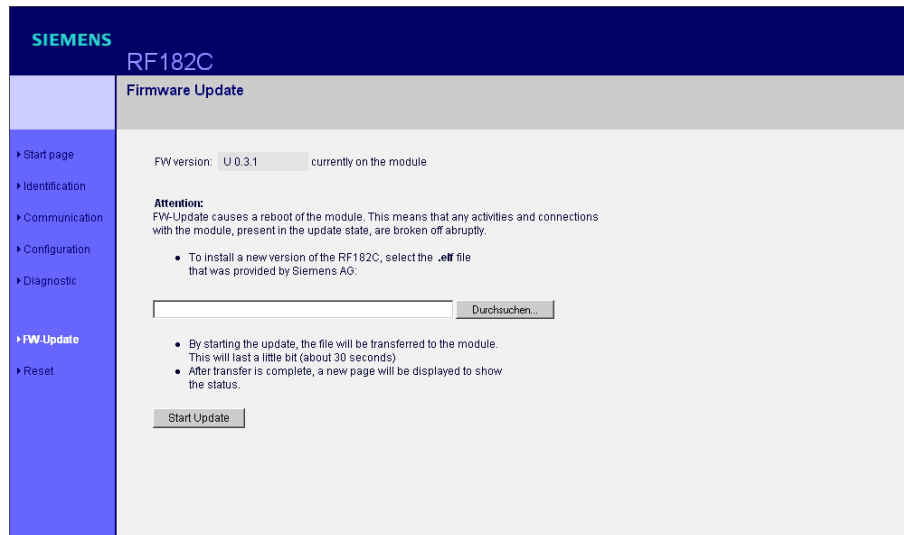

Figure 7-1 Firmware update

1. Save the update file (e.g. RF182C_V_2_0_0.elf"), which you received from Siemens, in the desired directory.
2. Enter the IP address of the communication module in the address field of your browser. The web server of the communication module opens.
3. Click the "Durchsuchen" button.
4. Select update file (RF182C_V_2_0_0.elf).
5. Start the firmware update via the "Start Update" button.

7.3 Reader update

In preparation.

8.1 Diagnostics using LEDs

The following figure shows details of the LEDs of the RF182C.

With connection block M12, 7/8"

With push-pull connection block

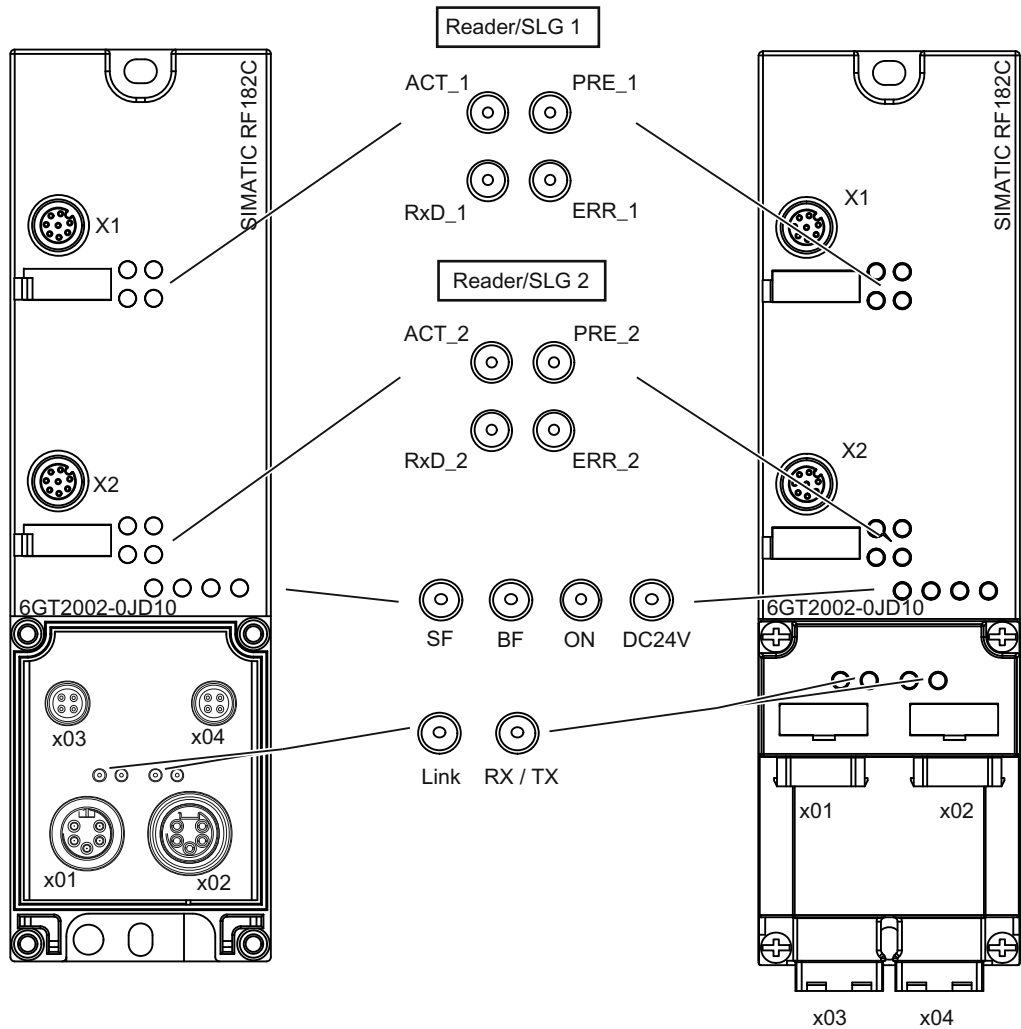

8.1 Diagnostics using LEDs

Table 8- 1 Status LEDs for the RF182C

LEDs	Meaning
ON	Lights up when the RF182C has completed start-up without errors.
24 V DC	Lights up when the 24 V supply voltage is connected to the RF182C.
ACT_1, ACT_2	Reserved
ERR_1, ERR_2	A flashing pattern indicates the last error to occur. These flashing patterns are described in Section Error messages (Page 71).
PRE_1, PRE_2	Indicates the presence of a tag/MDS.
RxD_1, RxD_2	Indicates live communication with the reader / SLG. May also indicate malfunctions on the reader / SLG.

Table 8- 2 LED display for Ethernet diagnosis

BF	SF	Cause of error	Error handling
On	–	<ul style="list-style-type: none"> Communication module is in start-up mode. No cable inserted 	Check the Ethernet cable.
Flashes	On	<ul style="list-style-type: none"> There is no TCP connection to the Ethernet controller. No client has connected. 	<ul style="list-style-type: none"> Check your Ethernet configuration using the PST tool.
Off	On	<ul style="list-style-type: none"> There is an error. The module has not received a reset or comDevSetConfig command on one channel. 	<ul style="list-style-type: none"> Send a reset or comDevSetConfig command.
Off	Off	<ul style="list-style-type: none"> Normal mode 	–

– = Status not relevant

Table 8- 3 LEDs on connection block

Link (green)	Tx / Tx (yellow)	Meaning
Off	Off	No physical connection over Ethernet.
On	Off	Physical connection over Ethernet, no data traffic
On	Flashes	Physical connection over Ethernet with data traffic
Off	On	Temporary state following switch-on

The table is equally applicable to the left and right Ethernet connection.

Other communication module operating modes are indicated by the PRE, ERR, ACT, SF and ON LEDs:

Table 8-4 LED display for operating states

ON	BF	SF	PRE_1	ERR_1	ACT_1	PRE_2	ERR_2	ACT_2	Description
Off	Off	Off	Off	Off	Off	Off	Off	Off	Start-up active
On	On	On	On	On	On	On	On	On	LED test on start-up (start Ethernet)
Off	Off	On	On	On	Off	On	On	Off	Internal fault
Off	Off	On	On	Off	On	On	Off	On	Checksum error of the firmware
Off	Off	On	Off	Slow flashing	Off	Off	Slow flashing	Off	Firmware update (flashes with every described area)
On	Flashes	On	Off	Flashes 1 x acc. to table 8-1	Off	Off	Flashes 1 x acc. to table 8-1	Off	Run-up cannot be parameterized. No client has connected.

Error messages

9.1 Response without error entry

Below the XML response without error entry is described:

XML response

```
<reply>
  <resultCode>0000</resultCode>
  <Name of the output command, e.g. reset/>
</reply>
```

9.2 Response with error entry

Below the XML response with error entry is described:

XML response

```
<reply>
  <resultCode>Errorcode</resultCode>
  <Name of the output command, e.g. reset/>
</reply>
```

The following table describes the possible error codes (**resultCodes**). The error codes are coded in 4 bytes.

9.3 Error messages of the RF182C

Table 9- 1 Error messages of the RF182C via the "resultCode" variable

Error code ASCII hex	Flashing of ERR LED ¹⁾	Description
0000	–	No error Default value if everything is ok.
	1x	No error The communication module has executed a start-up and is waiting for a RESET command.
0001	2x	Presence error: The MDS has moved out of the write/read device's transmission window. The MOBY command was executed only partially. Read command: No data is being transmitted to the client. Write command: The MDS which just left the field contains an incomplete data set. <ul style="list-style-type: none"> • Distance between write/read device and MDS not adhered to • Configuration error: The data set to be processed is too large (in dynamic mode) The next command is automatically executed on the next MDS. A read or write command is possible. <ul style="list-style-type: none"> • With timeout: No MDS in field
0002	2x	Presence error: An MDS has passed by a write/read device without being processed by a MOBY command. This error message is not reported immediately. Instead, the communication module is waiting for the next command (read, write). This command is immediately replied to with this error. This means that a read or write command is not processed. The next command is executed normally again by the communication module. A RESET command from the client also resets this error state. Bit 2 is set in the reset parameter option_1, or a reset command was sent and there is no MDS in the transmission window.
0003	3x	Error in the connection to the write/read device. Write/read device does not answer. <ul style="list-style-type: none"> • The cable between communication module and SLG is wired incorrectly or there is a cable break • The 24 V supply voltage is not connected or is not on or has failed briefly • Automatic fuse on the communication module has blown • Hardware defective • Another SLG is in the vicinity and is active • Interference injection on SLG line • Execute a RESET command after error correction
0004	4x	Error in MDS's memory The MDS has never been write-accessed or has lost the contents of its memory due to battery failure. <ul style="list-style-type: none"> • Replace MDS (if battery bit is set). • Install MDS with the STG. • Reinitialize MSD (see Section "Command parameter settings").

Error code ASCII hex	Flashing of ERR LED ¹⁾	Description
0005	5x	Unknown command The client is sending an uninterpretable command to the communication module. <ul style="list-style-type: none"> • Check the XML command • The MDS reported an address error
0006	6x	Field interference on write/read device The write/read device is receiving interference from its environment. <ul style="list-style-type: none"> • The distance between two write/read devices is too small and does not correspond to the configuration guidelines • The connecting cable to the write/read device is defective or too long or does not comply with the specification • MOBY U: MDS has left the field during communication. • MOBY U: Communication between write/read device and MDS was terminated by interference (e.g. person/foreign body moving between write/read device and MDS).
0007	7x	Too many transmit errors The MDS was not able to correctly receive the command or the write data from the communication module even after several attempts. <ul style="list-style-type: none"> • The MDS is positioned exactly on the boundary of the transmission window. • Data transmission to the MDS is being affected by external interference.
0008	8x	CRC sending error <ul style="list-style-type: none"> • The receiver monitor has detected at least one fault during transmission. <ul style="list-style-type: none"> – Cause same as error 0006 • MDS signaling CRC error frequently. <ul style="list-style-type: none"> – The MDS is positioned exactly on the boundary of the write/read device. – The hardware of the MDS and/or write/read device is defective.
0009	9x	Only during initialization: CRC error during acknowledgment receipt from MDS <ul style="list-style-type: none"> • Cause same as error 0006
000A	10x	Only during initialization: MDS is unable to perform the initialization command. <ul style="list-style-type: none"> • MDS is defective.
000B	11x	MOBY U: Memory of MDS cannot be read correctly.
000C	12x	Memory of the MDS cannot be write-accessed. <ul style="list-style-type: none"> • Memory of the MDS is defective. • EEPROM MDS was written too frequently and has reached the end of its service life
000D	13x	Address error The address area of the MDS was exceeded. <ul style="list-style-type: none"> • Check the XML command • The MDS is not the right type. • RF300: Attempted write access to write-protected areas (OTP area)

Error messages

9.3 Error messages of the RF182C

Error code ASCII hex	Flashing of ERR LED ¹⁾	Description
000E	14x	ECC error (only possible when ECC_mode = TRUE) The data could not be read by the MDS. <ul style="list-style-type: none"> Data of the MDS have been lost (MDS defective). The MDS was not initialized with ECC driver. <ul style="list-style-type: none"> Initialize MDS MDS with EEPROM has reached the end of its service life. The data have been lost. <ul style="list-style-type: none"> Replace the MDS → The MDS was moved out of the transmission window while being write-accessed <ul style="list-style-type: none"> The MDS is not positioned correctly → Command to the communication module was issued incorrectly by user
000F	1x	Run-up message from a reader that is connected to the communication module <ul style="list-style-type: none"> Carry out a RESET
0011	–	Short circuit or overload of the 24 V outputs (error code, presence) <ul style="list-style-type: none"> The affected output is turned off. All outputs are turned off when total overload occurs A reset can only be performed by turning the 24 V voltage off and on again. Then start RESET
0012	18x	Internal communication module communication error. <ul style="list-style-type: none"> Connector contact problem on the communication module Defective communication module hardware <ul style="list-style-type: none"> Return communication module for repair Start RESET after error correction
0013	19x	The communication module/SLG U does not have enough buffer storage to store the command intermediately.
0014	20x	Internal communication module/SLG error. <ul style="list-style-type: none"> Program execution error on the communication module Turn power of communication module off and on again. Start RESET after error correction MOBY U: Watchdog error on write/read device
0015	21x	Wrong parameterization of the communication module/SLG <ul style="list-style-type: none"> Check the parameterization RESET command is parameterized incorrectly After a start-up, the communication module has still not received a RESET
0016	22x	<ul style="list-style-type: none"> The communication module is unable to process the command. Client command (e.g. READ) issued with too much user data
0017	23x	Communication error <ul style="list-style-type: none"> Check the client command which causes this error Start RESET after error correction
0018	–	An error has occurred which must be acknowledged with a RESET. <ul style="list-style-type: none"> The RESET command is faulty. Transmit RESET after error correction

Error code ASCII hex	Flashing of ERR LED ¹⁾	Description
0019	25x	<p>Previous command is active or buffer overflow</p> <p>The user sent a new command to the communication module although the last command was still active.</p> <ul style="list-style-type: none"> • Active command can only be terminated with RESET. • Two client calls were parameterized with the same parameters • Start RESET after error correction • When command repetition is used, no data is fetched from the MDS. The data buffer on the communication module has overflowed. MDS data have been lost.
001C	28x	<p>The antenna of the write/read device is turned off. An MDS command to the communication module was started in this state.</p> <ul style="list-style-type: none"> • Turn on the antenna with the command "antenna on/off." • The antenna is turned on (off) and has received an additional turn-on (turn-off) command.
001D	–	<p>More MDSes are in the transmission window than the SLG is capable of processing simultaneously.</p> <ul style="list-style-type: none"> • Only 1 MDS can be processed at a time with a client
001E	30x	<p>Error when processing the function</p> <ul style="list-style-type: none"> • Communication module defective: The communication module receives wrong data during a RESET
001F	–	<p>Running command canceled by RESET</p> <ul style="list-style-type: none"> • Communication with the MDS was terminated by RESET • This error can only be reported if there is a RESET

¹⁾ The flashing ERR-LED can be implemented either on the communication module or on the reader.

9.3 Error messages of the RF182C

Table 9- 2 Error messages of the RF182C

Error code	Flashing of ERR LED	Description
3214	-	Fatal Error. Internal firmware error of the communication module <ul style="list-style-type: none"> • Turn the power supply of the communication module off and on again • Update the firmware to a new version, if applicable.
3221	-	Configuration required <ul style="list-style-type: none"> • Check configuration data or send it to communication module
3222	-	Conflicting configurations of the communication module. <ul style="list-style-type: none"> • The configuration module was already configured or is in default mode.
3223	-	Configuration faulty <ul style="list-style-type: none"> • Check configuration data to communication module
3321	-	Internal processing error <ul style="list-style-type: none"> • Turn the power supply of the communication module off and on again • Update the firmware to a new version, if applicable
3322	-	Buffer overflow in the communication module <ul style="list-style-type: none"> • The user is sending too many consecutive commands. • The communication module cannot transfer data to the user quickly enough or the user cannot receive the data quickly enough.
3323	-	Notification buffer overflow <ul style="list-style-type: none"> • Too many consecutive notification message frames that communicate results are received too quickly (presence). • The communication module cannot transfer data to the user quickly enough or the user cannot receive the data quickly enough.
3324	-	Alarm buffer overflow <ul style="list-style-type: none"> • Too many consecutive results are received too quickly via the alarm buffer (error messages). • The communication module cannot transfer data to the user quickly enough or the user cannot receive the data quickly enough.
3325	-	Internal data processing error in the communication module <ul style="list-style-type: none"> • Start RESET command.
3326	-	Error at the internal reader interface of the communication module <ul style="list-style-type: none"> • Start RESET command.
3417	-	Length error when receiving data via the TCP/IP connection. <ul style="list-style-type: none"> - Check if the TCP/IP data transmission over the line is executed properly
3421	-	Error in the configuration of the connection <ul style="list-style-type: none"> • Connection was not configured • Permissible number of connections was exceeded • Check and if necessary correct configuration.
3422	-	Error when sending data via the TCP/IP connection <ul style="list-style-type: none"> - Check if the TCP/IP data transmission over the line is executed properly
3423	-	Timeout when receiving data via the TCP/IP connection. <ul style="list-style-type: none"> • Increase the data transmission rate of a command from the user side.

Error code	Flashing of ERR LED	Description
3424	-	Error when receiving the TCP channel <ul style="list-style-type: none"> • Connection was aborted • TCP/IP protocol error • Permissible number of connections at one port was exceeded • Check socket programming on the user side or find the fault with network analyzer (Wireshark).
3425	-	Receiving buffer overflow <ul style="list-style-type: none"> • Previous command is still active • Check if maximum possible number of commands was exceeded.
3521	-	Incorrect UID <ul style="list-style-type: none"> • The length of the UID is not correct • A UID is required that has not been transferred by the user • Check UID
3523	-	Conversion error <ul style="list-style-type: none"> • Check if individual characters of the user data of a command exceed the permissible range for ASCII hex. (Range 0 – 9 or A – F). The number of characters must be an even number.
3550	-	Error in the XML structure of a command message frame. <ul style="list-style-type: none"> • Check command structure

Note**Error handling procedure**

If error messages occur, execute a reset command to eliminate the error.

If this procedure does not eliminate the error, disconnect the module from the power supply.

9.4 Diagnostics via Web server

9.4.1 Saving/reading of I&M data records

Via Identification&Maintenance data records you can store internal information on the module and retrieve it as required.

Save data records

Via the "Identification" menu in the "Settings" tab, various settings can be made and stored on the communication module. Use the "transmit and save" button to save the settings.

The screenshot shows the SIEMENS RF182C web interface. The top header is dark blue with the SIEMENS logo and the model number RF182C. Below the header, there is a navigation bar with 'Readout' and 'Settings' tabs. The 'Settings' tab is active. On the left side, there is a vertical menu with options: Start page, Identification, Communication, Configuration, Diagnostic, FW-Update, and Reset. The 'Identification' menu item is highlighted. The main content area is titled 'Identification' and contains a form with the following fields:

- Funktion: max. 32 Characters
- Location: max. 22 Characters
- Installation date: e.g. YYYY-MM-DD hh:mm, max. 16 Characters
- Comment: max. 54 Characters

At the bottom of the form, there is a button labeled 'transmit and save' and a note: 'Inputs stored persistently on the RF182C'.

Read data records

To read out the data records from the communication module, switch to the "Identification" menu in the "Readout" tab.

The screenshot shows the SIEMENS RF182C web interface. The top navigation bar includes 'SIEMENS' and 'RF182C'. Below this, there are tabs for 'Readout' and 'Settings', with 'Readout' being the active tab. A left-hand menu contains several options: 'Start page', 'Identification', 'Communication', 'Configuration', 'Diagnostic', 'FW-Update', and 'Reset'. The main content area is titled 'Identification' and contains the following information:

- Identification:**
 - Function (plant ID): Test
 - Location (site ID): Fürth
 - Installation date: 09.09.2010
 - Comment: Test
- Serial number: S C-X7VR41402009
- Version:**
 - Hardware:
 - Firmware: U 0.3.1
- Order number:**
 - Hardware: 6GT2 002-QJD10

9.4.2 Communication status query

You can query the communication status of the RF182C communication module via the menu "Communication" in the Connection "tab". You can see the status of the user connection.

The screenshot shows the SIEMENS RF182C web interface. The top navigation bar includes 'SIEMENS' and 'RF182C'. Below this, there are tabs for 'Parameter', 'Connections', 'Statistics', and 'Settings', with 'Connections' being the active tab. A left-hand menu contains several options: 'Start page', 'Identification', 'Communication', 'Configuration', 'Diagnostic', 'FW-Update', and 'Reset'. The main content area is titled 'Communication' and displays a table of TCP connections:

TCP Connections:						
Dedicated to Reader	Local IP Address:	Local Port:	Status:	Remote IP Address:	Remote Port:	
1	192.168.0.4	10001	connected	192.168.0.5	01150	
2	192.168.0.4	10002	not connected	---	---	

9.4.3 Event and message frame overview

Event overview

Via the "Diagnostic" menu in the "Events " tab, you can query the events of the module.

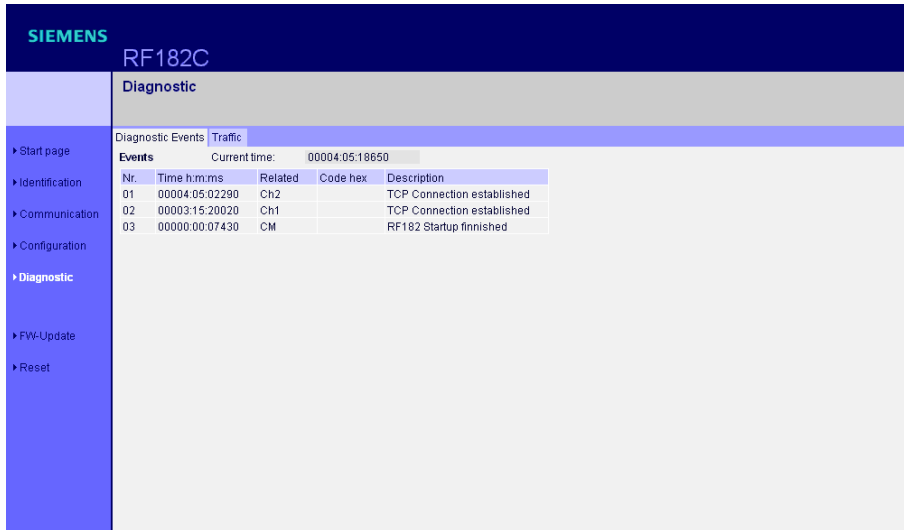

Message frame overview

Via the "Diagnostic" menu in the "Traffic " tab, you can query the last twenty message frames of the communication module.

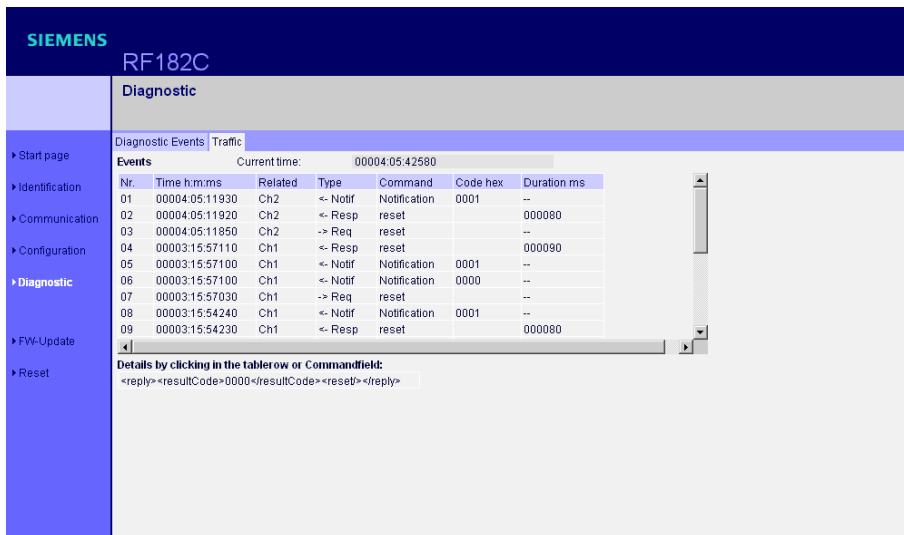

Examples/applications

10.1 Basic principles of socket programming, exemplary in C

10.1.1 Socket programming requirements

Definition

A socket is the end point of a communication connection. All modern operating systems nowadays have a socket application interface. This software interface permits access to the TCP/IP stack on the operating system used.

Requirements

- An operating system/programming language must be used that supports network programs with sockets.
- Sockets are supported by the following operating systems: Microsoft Windows 95/98/ME/2000/XP/Vista, Linux, Unix. Other operating systems must be considered with regard to the usability of network programs.
- Sockets are used by many programming languages (e.g. C, C++, C#, Delphi, VB, Java). Other programming languages must be considered with regard to the usability of network programs.

10.1.2 Basic client/server principle

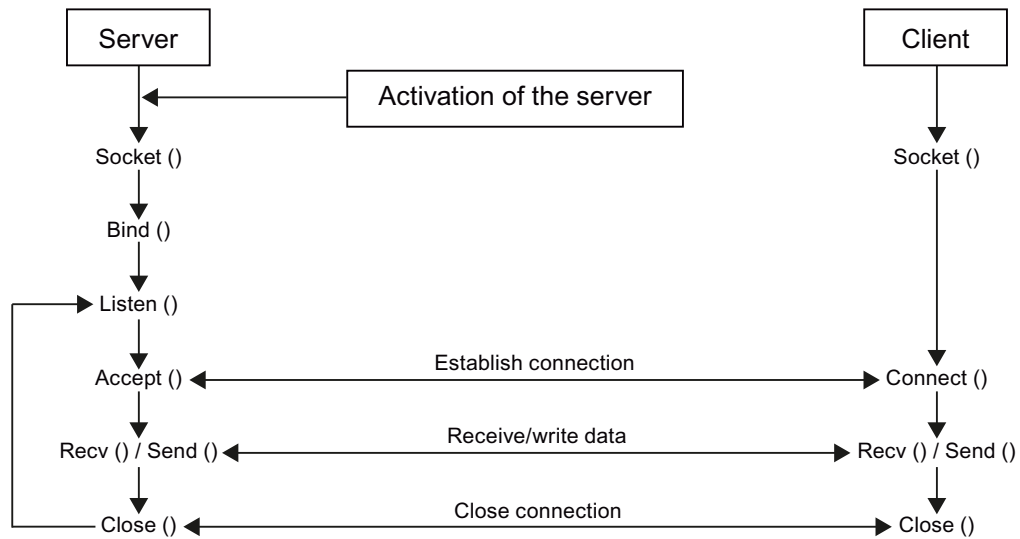

Figure 10-1 Basic client/server principle

10.1.3 Important basic commands

Commands/functions	Description
Socket()	Initialization and parameter transfer of a new socket
Bind()	Assignment of a user (IP address and port number) to a socket
Lists()	Ready to connect
Connect()	Function for connecting the client to the server via TCP/IP
Accept()	Wait function of server until a client connects
Send()	Sending data
Recv()	Receiving data
Close()	Closing the socket after completing data transmission. When working with the RF182C, a Close usually only occurs when the system is shut down.

Note

No parameters or return values of the individual functions are listed here since they may differ in the different operating systems/programming languages.

The names of the functions are examples only, they may differ in the operating systems/programming languages. These function examples are limited to the basic principles of the client/server representation – only a partial example of the functions is shown.

10.1.4 Partial programming example of a client in C/Windows operating system

Under Windows, the header file "winsock.h" or the library "wsock32.lib" must also be integrated.

These must be initialized before calling the Windows sockets.

/*Init Windows Sockets*/

```
{
WSADATA wsadata;

    if( WSStartup( MAKEWORD( 1,1 ), &wsadata ) == 0 )
    {
        /*Initialization successful*/
    }
    else
    {
        /*Error during initialization*/
    }
}
```

/*Extract from main function*/

```
SOCKET Client;          // variable for socket handle
SOCKADDR_IN adr;       // variable for storing the target information
char caBuf[ 1500 ];    // the XML command or XML result is stored in this variable.

int nLen;              // Length of the send/receive data
```

/*Initialization of target information prior to connecting*/

```
adr.sin_family = AF_INET;    // Selection of the address family/Internet //connection-
oriented
adr.sin_port =                // Assignment of port number:10001
adr.sin_addr.s_addr =        // Assignment of IP address: 192.168.0.100
/* Creation of a socket - function returns the handle from the socket
SOCK_STREAM - connection-oriented protocol TCP*/
Client = socket( AF_INET, SOCK_STREAM, 0 );
```

/*Connection establishment*/

```
if( connect(Client, (SOCKADDR*)&adr, sizeof( adr ) ) < 0)
{
    //Error has occurred
}
else
{
    //Connection OK
}
```

/*Sending data*/

```
nLen = send( Client, caBuf, nLen, 0 );
if( nLen > 0 )
{
    // Data was sent successfully
}
else
{
    // Error on sending
}
```

/*Receiving data*/

```
nLen = recv( Client, caBuf, sizeof( caBuf ) - 1, 0 );
if( nLen > 0 )
{
    // Data was received
    // The data can be read in the caBuf array
}
else
{
    // Error occurred while receiving
// Connection termination if applicable
}
```

/*Close connection*/

```
    closesocket( Client );
```

10.2 RF182C user application

To permit user-friendly operation, there is an application available for the PC. The application is created in C# and can run direct on any Windows PC. You can load, modify, and expand the PC in your development environment. This application can be used as a basis for your application.

You can find the application on the RFID CD "Software&Documentation", Edition 2009 or later. On the user interface, follow the link "CM/ASM > RF182C > Demo". You can start the program directly.

Requirements

- Operating system: Windows XP
- Development environment: Microsoft Visual Studio 2008

Procedure

The application can be started direct via the user interface of the CD.

The sources of the application are stored in a zip file on the CD. You will find the file under "Data/Tools > Applications/RF182C".

Functions

This application offers the following functions:

- Establish connection
- Disconnect
- Notes on connection
- Input window for entering the commands
- Transfer of the commands to the RF182C communication module
- Display window for monitoring the communication process of the RF182C (acknowledgements and error messages)

10.2.1 User interface layout

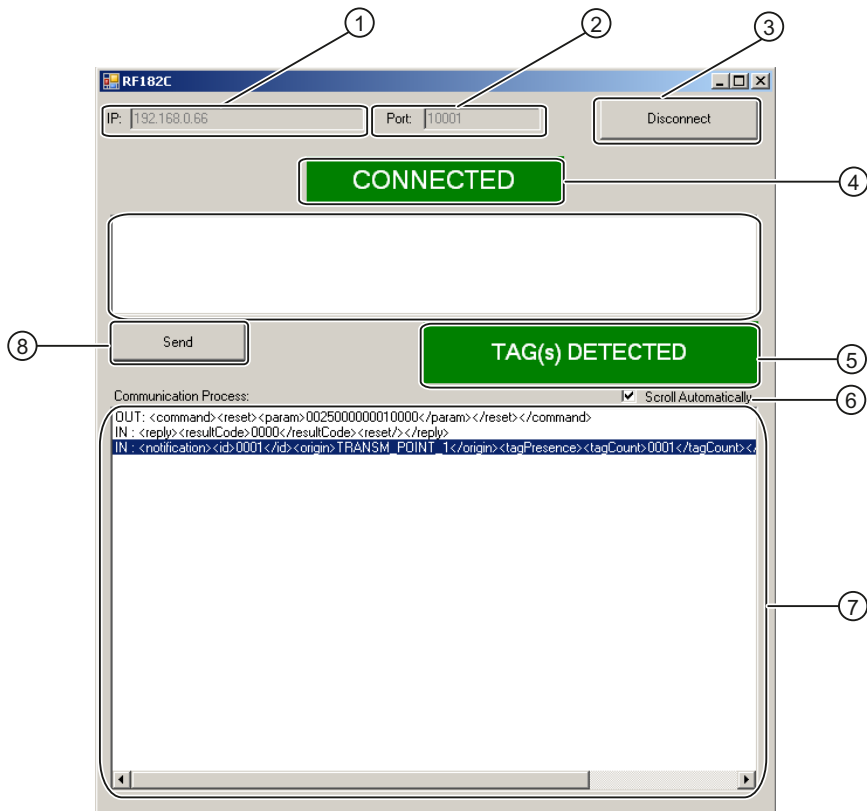

- ① IP address input window
- ② Port number input window
- ③ Button for connecting or disconnecting
- ④ Note: Connected or not connected
- ⑤ Note: Presence or no presence
- ⑥ Check box: The output window scrolls automatically or does not scroll automatically
- ⑦ Output window for receive data
- ⑧ Button for sending data in the input window

Figure 10-2 User interface

10.2.2 Extracts example code of the user application in C#

```
using System;
using System.Collections.Generic;
using System.ComponentModel;
using System.Data;
using System.Drawing;
using System.Text;
using System.Windows.Forms;
using System.Net;
using System.Net.Sockets;
using System.Web;

namespace RF182CApp

    public partial class MainForm : Form
    {
        // Socket to realize TCP/IP connection
        private Socket Connection = null;
        // connected (true) or not (false)
        private bool ConnectionState = false;
        // buffer for received data
        private String ReceiveBuffer = "";
        // Indicator for an error in asynchronous receive threads
        bool AsyncError = false;

        public MainForm()
        {
            InitializeComponent();
        }

        /* This routine is called when the window is initialized. */
        private void MainForm_Load(object sender, EventArgs e)
        {
            //We're not connected at the beginning
            SetConnectionState(false);
        }

        /* This routine is called when the Connect / Disconnect button
        * is clicked.
        * */
        private void bConnect_Click(object sender, EventArgs e)
        {
            if (ConnectionState == true) //already connected --> close connection
            {
                /* Connection may be disposed already (i.e. if an error
                * occurred before.
                * */
                if (Connection != null)
                {
                    //Close the socket
                    Connection.Close();
                }
            }
        }
    }
}
```

```

        }
        SetConnectionState(false);
    }
    else //not connected --> connect
    {
        //Try to connect the socket as client.
        if (Connect() == true)
        {
            // Connection was established successfully
            SetConnectionState(true);
        }
    }
}

/* This function enables/disables controls needed to set up
 * the connection and those needed to communicate separately from
 * each other.
 * */
private void Enable(bool enableConnectionData, bool enableCommunicationData)
{
    editIP.Enabled = enableConnectionData;
    editPort.Enabled = enableConnectionData;

    editMessage.Enabled = enableCommunicationData;
    buttonSend.Enabled = enableCommunicationData;
}

/* Sets the connection state to true (connected) or false
 * (not connected) with all necessary consequences (starting/stopping
 * timers, changing colors, texts and the serviceability of the
 * controls.
 * */
private void SetConnectionState(bool state)
{
    if (state == true)
    {
        ConnectionState = true;
        // Visualization
        Enable(false, true);
        labelConnectionState.Text = "CONNECTED";
        labelConnectionState.BackColor = Color.Green;
        buttonConnect.Text = "Disconnect";
        // Start UpdateTimer
        UpdateTimer.Start();
    }
    else
    {
        ConnectionState = false;
        //Stop UpdateTimer
        UpdateTimer.Stop();
        //Now, we don't know anything about tags in the field
    }
}

```



```
        SetTagDetectionState(TagDetectionState.UNDEFINED);
        //There may be uncollected data in the buffer --> call ParseBuffer()
        ParseBuffer();
        // Visualization
        Enable(true, false);
        labelConnectionState.Text = "NOT CONNECTED";
        labelConnectionState.BackColor = Color.Red;
        buttonConnect.Text = "Connect";
        AsyncError = false;
    }
}

/* Connects a stream based TCP/IP socket as client. */
private bool Connect()
{
    try
    {
        //Collect port and IP from the window.
        int port = 0;
        if (Int32.TryParse(editPort.Text, out port) == false || port <= 0)
        {
            MessageBox.Show(editIP.Text + " is not a legal port");
            return false;
        }

        IPHostEntry hostEntry = null;

        // Get host related information.
        hostEntry = Dns.GetHostEntry(editIP.Text);

        // Loop through the AddressList to obtain the supported AddressFamily. This is to avoid
        // an exception that occurs when the host IP Address is not compatible with the address
        family
        // (typical in the IPv6 case).
        for each (IPAddress address in hostEntry.AddressList)
        {
            IPEndPoint ipe = new IPEndPoint(address, port);
            // stream based TCP/IP socket
            Socket tempSocket = new Socket(ipe.AddressFamily, SocketType.Stream, ProtocolType.Tcp);

            // the actual connect
            tempSocket.Connect(ipe);

            if (tempSocket.Connected)
            {
                //a connection was established successfully
                Connection = tempSocket;
                Connection.ReceiveTimeout = 25;
                break;
            }
        }
        if (Connection == null) return false;
    }
}
```

```
        //Start asynchronous receive
        ReceiveString s = new ReceiveString();
    Connection.BeginReceive(s.buffer, 0, ReceiveString.BufferSize, 0, new
    AsyncCallback(ReceiveCallback), s);
        return true;

    }
    catch (Exception ex)
    {
        MessageBox.Show(ex.Message, "Connecting Failed");
        return false;
    }
}

/* This routine is called if there is new data in the asynchronous
 * receive available. The data is stored in ReceiveBuffer so that
 * it can be collected by the synchronous timer UpdateTimer.
 * */
private void ReceiveCallback(IAsyncResult res)
{
    try
    {
        if (ConnectionState == true)
        {
            // Collect data
            int size = Connection.EndReceive(res);
            ReceiveString s = (ReceiveString)res.AsyncState;
            // Without a lock we might cause race situations
            lock (ReceiveBuffer)
            {
                //Store data in buffer
                ReceiveBuffer += Encoding.ASCII.GetString(s.buffer, 0, size);
            }

            //Start new asynchronous receive
            ReceiveString rs = new ReceiveString();
    Connection.BeginReceive(rs.buffer, 0, ReceiveString.BufferSize, 0, new
    AsyncCallback(ReceiveCallback), rs);
        }
    }
    catch (Exception ex)
    {
        // An error occurred --> report it
        AsyncError = true;
        MessageBox.Show(ex.Message);
    }
}

//This routine is called when the Send button is clicked
private void buttonSend_Click(object sender, EventArgs e)
{
```

```
//only do something if there is a message specified
if (editMessage.Text != "")
{
    // convert to byte array
    byte[] buffer = Encoding.ASCII.GetBytes(editMessage.Text.ToCharArray());
    try
    {
        // Send!
        int count = Connection.Send(buffer);
        // Did we send everything?
        if (count != buffer.Length)
        {
            MessageBox.Show("Sending failed!");
            SetConnectionState(false);
        }
        //Show the message in the list.
        AppendOutMessage(editMessage.Text);
    }
    catch (Exception ex)
    {
        SetConnectionState(false);
        //An error occurred
        MessageBox.Show(ex.Message);
    }
    //Empty the editbox
    editMessage.Text = "";
}
}

/* This routine is called when UpdateTimer ticks. This happens
 * synchronous to the thread owning the dialog, hence we can
 * manipulate the list.
 * */
private void UpdateTimer_Tick(object sender, EventArgs e)
{
    if (AsyncError == true)
    {
        //An error occurred!
        SetConnectionState(false);
    }
    else
    {
        ParseBuffer();
    }
}

/* Parses ReceiveBuffer for complete XML telegrams and appends
 * them to the list.
 * */
private void ParseBuffer()
{
    // Without a lock we might cause race situations
```

```

// (ReceiveCallback is asynchronous)
lock (ReceiveBuffer)
{
    for (XMLTag tag = FirstTag(); tag != null; tag = FirstTag())
    {
        // Extract the parsed message and append it
        String message = ReceiveBuffer.Substring(tag.startIndex, tag.length);
        AppendInMessage(message);
        // Remove parsed message from ReceiveBuffer
        ReceiveBuffer = ReceiveBuffer.Substring(tag.startIndex + tag.length);
        // See if we got information about detected tags
        if (message.Contains("<tagCount>"))
        {
            if (message.Contains("<tagCount>0000</tagCount>"))
            {
                //There are no tags in the field
                SetTagDetectionState(TagDetectionState.NO);
            }
            else
            {
                // There are tags in the field
                SetTagDetectionState(TagDetectionState.YES);
            }
        }
    }
}

// Looks for the first complete XML telegram in ReceiveBuffer.
private XMLTag FirstTag()
{
    // Is there a reply, a notification or an alarm
    int index1 = ReceiveBuffer.IndexOf("<reply>");
    int index2 = ReceiveBuffer.IndexOf("<notification>");
    int index3 = ReceiveBuffer.IndexOf("<alarm>");

    if( index1== -1 && index2== -1 && index3== -1) return null; //No XML tag found

    if (index1 == -1) index1 = Int32.MaxValue;
    if (index2 == -1) index2 = Int32.MaxValue;
    if (index3 == -1) index3 = Int32.MaxValue;

    //Assume that the first tag is an alarm
    String endTag="</alarm>";
    XMLTag tag = new XMLTag();
    tag.type="alarm";
    tag.startIndex = index3;

    //See if this is true and change it if necessary
    if (index1 < index2 && index1 < index3)
    {

```

```
        // first tag is a reply
        endTag = "</reply>";
        tag.type = "reply";
        tag.startIndex = index1;
    }
    else if (index2 < index3)
    {
        // first tag is a notification
        endTag = "</notification>";
        tag.type = "notification";
        tag.startIndex = index2;
    }

    //Is the complete message in the buffer?
    int endIndex = ReceiveBuffer.IndexOf(endTag, tag.startIndex);
    if (endIndex == -1) return null;

    tag.length = endIndex - tag.startIndex + endTag.Length;

    return tag;
}

// Appends an outgoing message to the list
private void AppendOutMessage(String message)
{
    //Remove all CR and LF
    message.Replace("\r", "");
    message.Replace("\n", "");
    //Add message
    int index = listProcess.Items.Add("OUT: " + message);
    //Scroll if desired
    if (checkScroll.Checked == true)
    {
        listProcess.SelectedIndex = index;
    }
}

// Appends an ingoing message to the list
private void AppendInMessage(String message)
{
    //functionality just lie AppendOutMessage
    message.Replace("\r", "");
    message.Replace("\n", "");
    int index = listProcess.Items.Add("IN : " + message);
    if (checkScroll.Checked == true)
    {
        listProcess.SelectedIndex = index;
    }
}

/* Call this function if a tag appeared / disappeared. */
private void SetTagDetectionState(TagDetectionState state)
```

```
    {
        switch (state)
        {
            case TagDetectionState.YES:
                labelTagDetected.Text = "TAG(s) DETECTED";
                labelTagDetected.BackColor = Color.Green;
                break;
            case TagDetectionState.NO:
                labelTagDetected.Text = "NO TAG DETECTED";
                labelTagDetected.BackColor = Color.Red;
                break;
            case TagDetectionState.UNDEFINED:
                labelTagDetected.Text = "";
                labelTagDetected.BackColor = BackColor; //Color of the dialog
                break;
        }
    }
}

/* As long as no tag presence notification was send, we have no
 * information whether there is a tag in the field or not.
 * --> three states
 * */
enum TagDetectionState
{
    YES, NO, UNDEFINED
}

// This class is for handling asynchronous communication processes
internal class ReceiveString
{
    public read-only static int BufferSize = 512;
    public byte[] buffer = new byte[BufferSize];
}

// This class describes a XML block in ReceiveBuffer
internal class XMLTag
{
    //Index of first character
    public int startIndex;
    //Block length
    public int length;
    // Type ( reply, notification or alarm, since only telegrams
    // from the ASM are handled within this structure)
    public String type;
}
}
```

10.2.3 Functions of the RF182C applications

The following screenshots show the different functions of the RF182C application:

Example of working with the application

1. First enter the IP address and port number in the corresponding entry fields.

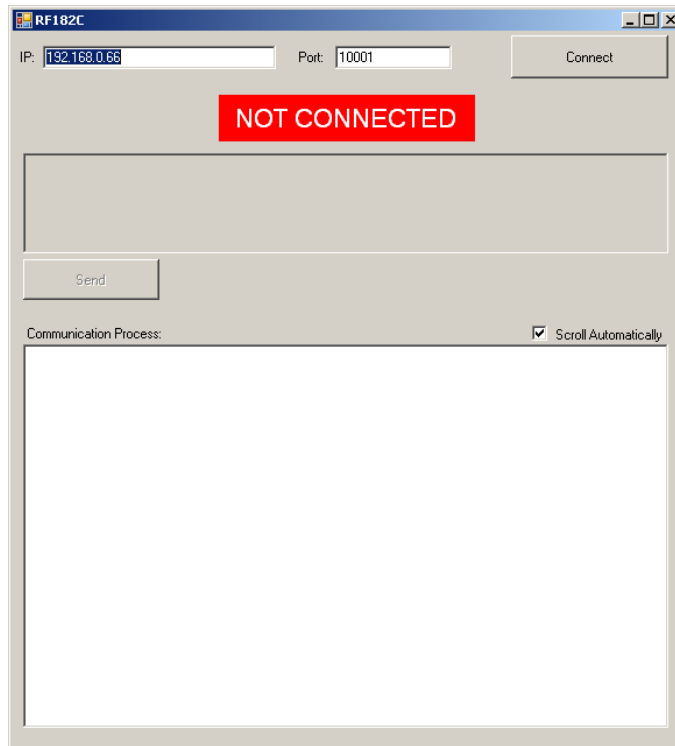

Figure 10-3 RF182C not connected

2. Then click "Connect".

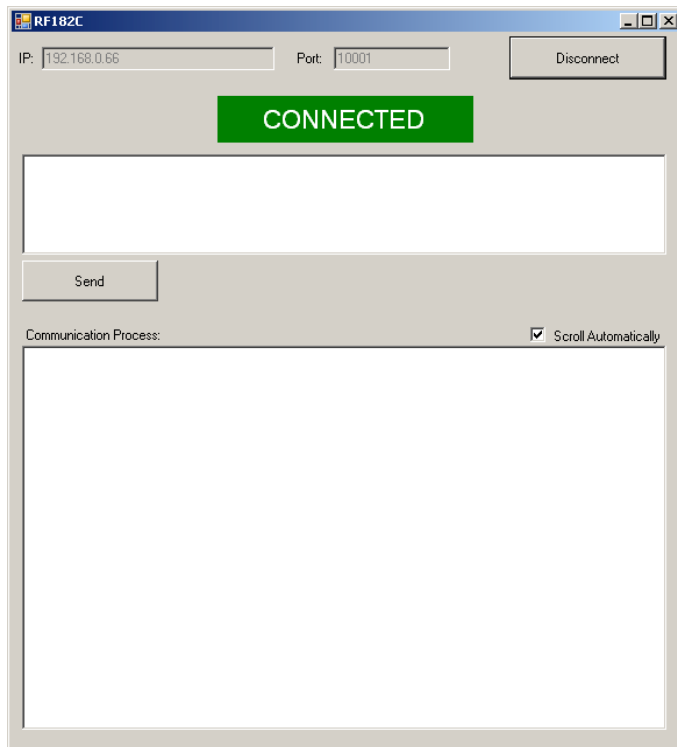

Figure 10-4 Connected successfully

The connection to the RF182C has been established successfully. The send window is empty after sending successfully.

3. Enter a RESET command in the input window. Click the "Send" button.

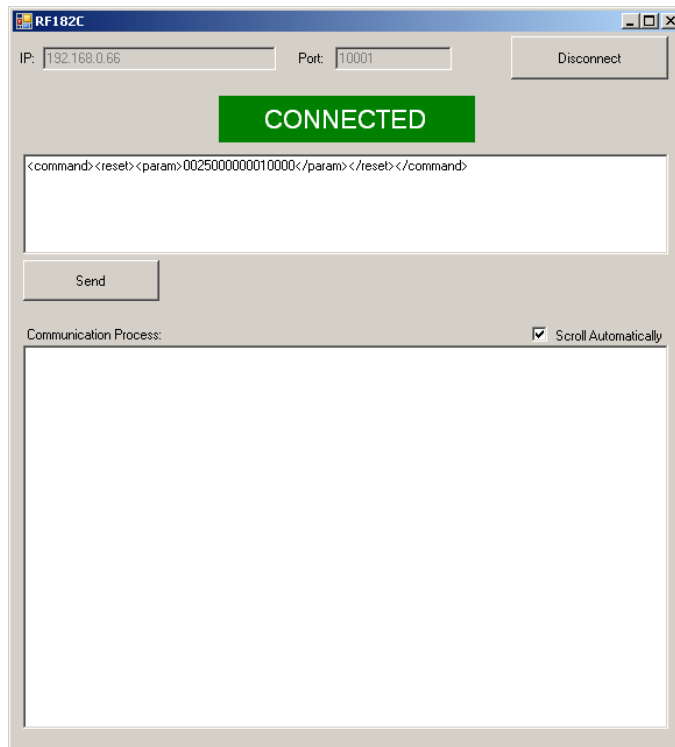

Figure 10-5 RESET command

The RF182C communication module operates in default mode.

- 4. The next window shows that the RESET command has been sent successfully. The RF182C has sent an acknowledgement with the error code "0000" (everything OK). It is indicated that a tag has been detected in the antenna field of the reader (0001).

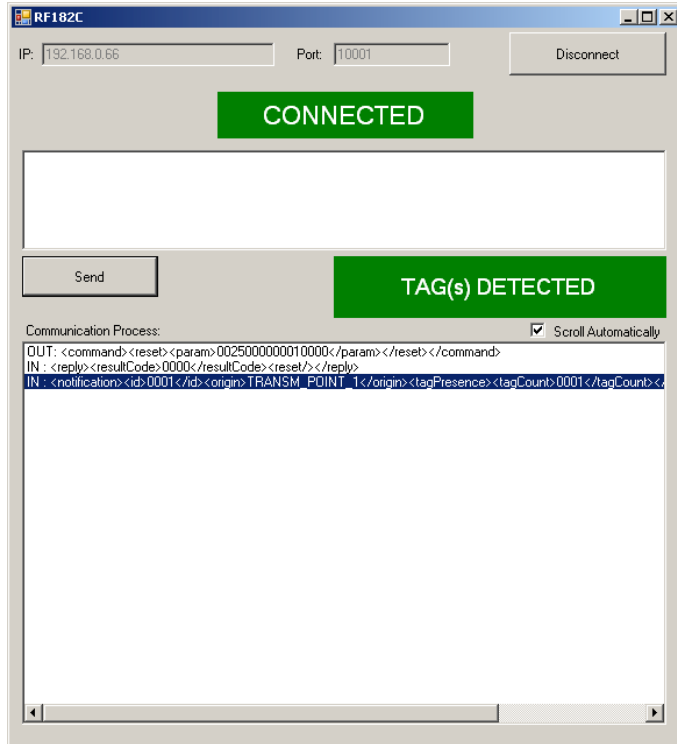

Figure 10-6 Tag detected

5. The next window shows that the tag has exited the reader's antenna field again (0000)

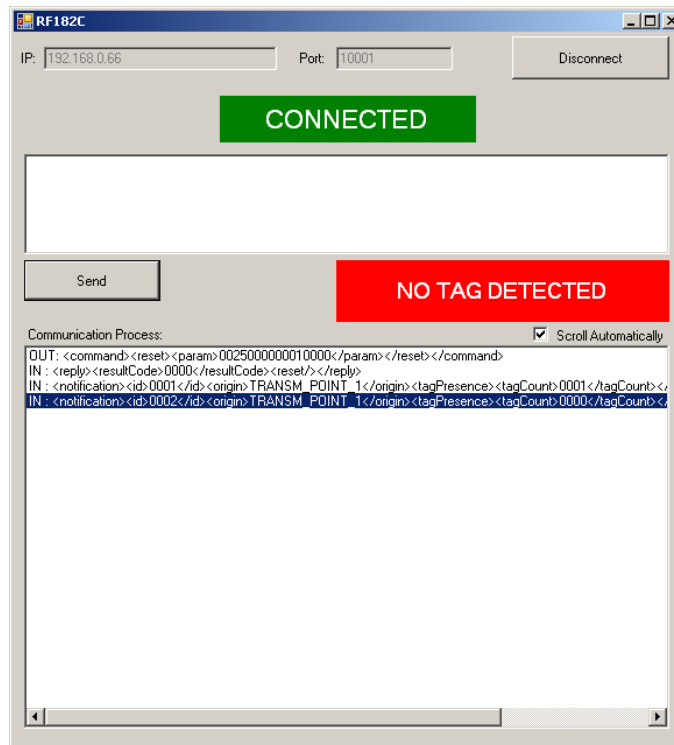

Figure 10-7 Tag exited the field

10.3 Example application for a PLC according to DIN IEC 61131

In preparation.

Technical data

Table 11- 1 General technical data

Ethernet interface to the user		
Principle	Ethernet	
Physical medium	Ethernet (TCP/IP communication)	
Duty type	<ul style="list-style-type: none"> • 10BASE-T Full or Half Duplex • 100BASE-TX Fast Ethernet Full or Half Duplex 	
Transmission rate	10/100 Mbit/s	
Plug-in connection	M12, 4-pin, D coding	
Maximum cable length	100 m	
Cable type	STP Cat 5	
Autonegotiation	Yes	
Autocrossing	Yes	
Switch function	Yes, internal	
Serial interface to the reader/SLG		
Connector	2 x M12 coupler plugs, 8-pin	
Max. cable length	1000 m, dependent on Reader/SLG (2 m = standard length; for other standard cables and self-assembled cables, refer to Section <i>Connection cables</i>)	
Connectable readers/SLGs	2x readers/SLG of the RFID families RF300, RF600, MOBY D/U	
Software functions		
Tag/MDS addressing	Direct access via addresses	
Commands	Initialize tag, read data from tag, write data to tag, etc.	
Supply voltage¹⁾		
Rated value	24 V DC	
Permissible range	20 V to 30 V DC	
Current consumption without reader / SLG ²⁾	max. 500 mA; typ. 100 mA	
Current consumption through reader connection	Each 500 mA	
Maximum infeed current in the connection block M12, 7/8"	1L = 6 A 2L = 8 A	
Maximum infeed current in the push-pull connection block	Up to 40 °C: 1L = 12 A ³⁾ 2L = 12 A	Up to 60 °C: 1L = 8 A 2L = 8 A
Galvanic isolation	Yes	

Ambient temperature	
During operation	0 to +60 °C
Transport and storage	-40 to +70 °C
Dimensions (W x H x D) in mm	
Base unit only	60 x 210 x 30
Base unit with connection block M12, 7/8"	60 x 210 x 54
Base unit with push-pull connection block	60 x 216 x 100
Weight	
Base unit	Approx. 210 g
Connection block M12, 7/8"	Approx. 230 g
Push-pull connection block	Approx. 120 g
Mechanical Environmental Conditions	
Mounting position	All mounting positions are possible
Vibration during operation	According to IEC 61131-2: 0.75 mm (10Hz to 58 Hz) 10 g (58 Hz to 150 Hz)
Shock resistance, shock during operation	Acc. to IEC 61131-2: 30 g
Degree of protection	IP67
MTBF (Mean Time Between Failures) in years	
Base unit	121
Connection block	1100
Approvals	cULus (file E116536) FCC Code of Federal Regulations, CFR 47, Part 15, Sections 15.107 and 15.109 (Class A)

- 1) All supply and signal voltages must be safety extra low voltage (SELV/PELV according to EN 60950)
24 V DC supply: Safety (electrical) isolation of low voltage (SELV / PELV acc. to EN 60950)
- 2) The power supply must provide the current required (max. 500 mA) during brief power failures of ≤ 20 ms.
- 3) **A cable cross-section of 2.5 mm² is mandatory for an amperage > 8 A.**

Dimension drawings

12.1 Dimension drawing for RF182C with fixing holes

Dimension drawing of an RF182C with bus connection block M12, 7/8" PN PN

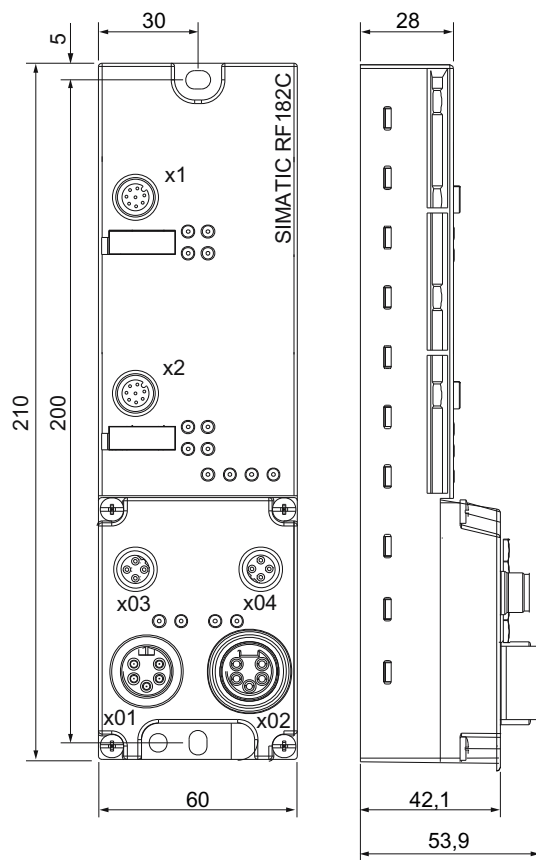

Figure 12-1 Dimension drawing of an RF182C with bus connection block M12, 7/8"

Dimension drawing of an RF182C with push-pull bus connection block

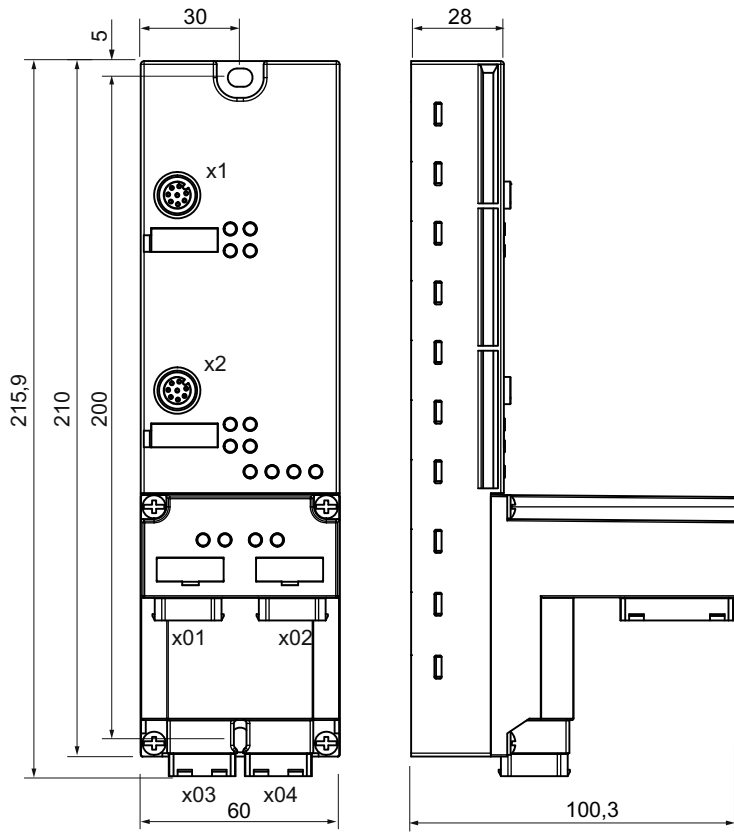

Figure 12-2 Dimension drawing of an RF182C with push-pull bus connection block

Connecting cable to the reader/SLG

13.1 Routing of standard cables

Available cables



Figure 13-1 Connecting cable, M12 ↔ Reader / SLG; l = 2 m, 5 m (MOBY U)

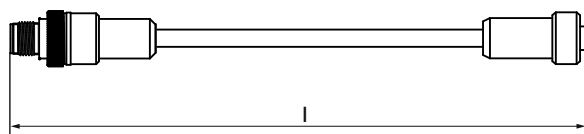

Figure 13-2 Connecting cable/extension cable M12 ↔ M12; l = 2 m, 5 m, 10 m, 20 m, 50 m

- Connecting cable RF300/RF600; MOBY D only 6GT2602-0AB10-0AX0
- Extension cable for all RFID systems

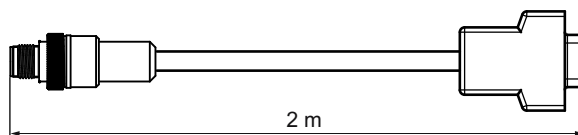

Figure 13-3 Connecting cable M12 ↔ sub-D (MOBY D all SLGs except 6GT2602-0AB10-0AX0)

Maximum cable length

The RF182C can be operated with any reader/SLG configuration with a maximum cable length of 50 m.

Longer connecting cables of up to 1000 m are possible in some instances. The current consumption of the connected reader/SLG must however be taken into account. You will find information in the relevant system manuals.

Sequential arrangement of more than two sub-sections to form a long section of cable should be avoided due to the additional contact resistances.

13.1 Routing of standard cables

Pin assignment

Table 13- 1 Connecting cable M12 ↔ Reader / SLG

M12 connector (male)		Reader/SLG connector (female)	
	1	2	
	2	5	
	3	3	
	4	4	
	5	6	
	6	1	
	7	–	
	8	7	

Table 13- 2 Connecting cable / extension cable M12 ↔ M12

	1	1	
	2	2	
	3	3	
	4	4	
	5	5	
	6	6	
	7	7	
	8	8	

Table 13- 3 Connecting cable M12 ↔ sub-D 9-pin

M12 connector (male)		Sub-D connector (female)	
	1	–	
	2	5	
	3	7	
	4	3	
	5	2	
	6	6	
	7	–	
	8	1, 8	

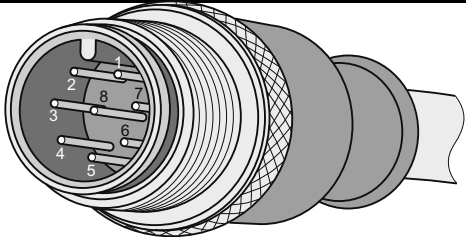
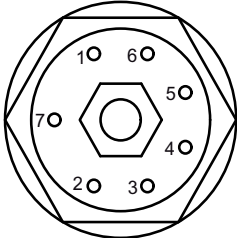
Note:
Reader/SLG with Sub-D connector must be supplied over an additional connector with 24 V DC.

13.2 Self-assembled cable

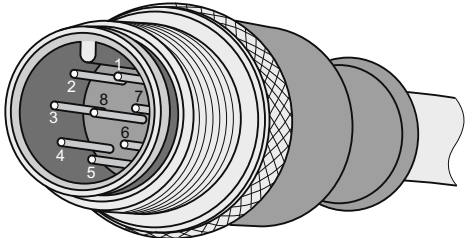
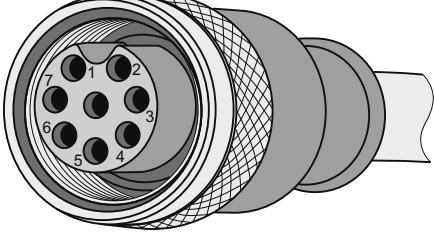
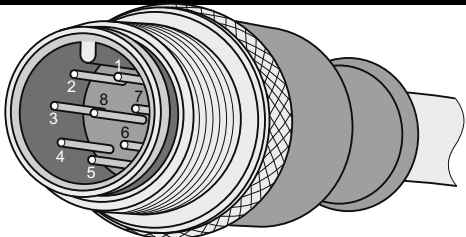
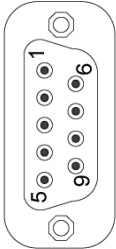
A reader/SLG connector plug with screw terminals is provided for users who want to individually pre-assemble their own cables (refer to the relevant system manual). Cables and reader/SLG connector plugs can be ordered from the Catalog *FS 10 Sensors for Production Automation*.

Cable structure

You will need cables of the following specifications for self-assembled cables:

7 x 0.25 mm²
 LiYC11Y 7 x 0.25

Connectors

M12 connectors can be obtained from the relevant specialist dealers (e.g. Binder).

Pin assignment

The pin assignment is listed in the following table.

Table 13- 4 Pin assignment

M12 connector (male)	Pin	Signal	Core color
	1	1L+ (+ 24 V)	Note data sheet provided by cable manufacturer
	2	-RxD	
	3	0 V	
	4	RxD	
	5	TxD	
	6	-TxD	
	7	Free	
	8	Functional ground (PE)/shield	

Table 14- 1 RF182C ordering data and accessories

RF182C	
RF182C communication module max. 2 SLGs or readers can be connected	6GT2002-0JD10
Connection block M12, 7/8" (5-pole)	6GT2002-1JD00
Connection block M12, 7/8" (4-pole)	6GT2002-4JD00
Push-pull connection block, RJ45	6GT2002-2JD00
Labels 20 x 7 mm (1 pack = 340 items)	3RT1900-1SB20
Accessories for connection block M12, 7/8" (5-pole)	
IE plug-in cable for PROFINET/Ethernet (pre-assembled trailing cable with two M12 connectors, 4-pin, code D)	6XV1870-8Axxx ¹⁾
7/8"-plug-in cable for supply voltage (5 x 1.5 mm ²) (pre-assembled trailing power cable with two 5-pin 7/8" connectors)	6XV1822-5Bxxx ¹⁾
Trailing power cable (5 x 1.5 mm ²) (not pre-assembled; length min. 20 m, length max. 1000 m)	6XV1830-8AH10
Connector plug 7/8" for supply voltage; (1 pack = 5 items) <ul style="list-style-type: none"> • with pin insert • with socket insert 	6GK1905-0FA00 6GK1905-0FB00
RJ45 plug-in cable with metal casing and FC connection system, 180 ° cable outlet;(1 pack = 1 item)	6GK1901-1BB10-2AA0
Control cabinet feedthrough for conversion from M12 connection method (D coded, IP65) to RJ45 connection method (IP20) ;(1 pack = 5 items)	6GK1901-0DM20-2AA5
M12 plug-in cable with metal casing and fast connection system, 180 ° cable outlet (D coded) ; (1 pack = 1 item)	6GK1901-0DB10-6AA0
M12 covering caps	3RX9802-0AA00
Covering caps 7/8" (1 pack = 10 items)	6ES7194-3JA00-0AA0
PROFINET/Ethernet standard cable 2x2, Type A, unassembled; minimum order quantity 20 m	6XV1840-2AH10
Accessories for connection block M12, 7/8" (4-pole)	
Cable for supply voltage pre-assembled with 7/8" 4-pole connectors (only for 6GT2002-4JD00)	Not available from Siemens

Accessories for push-pull connection block	
Trailing power cable (5 x 1.5 mm ²) (not pre-assembled; length min. 20 m, length max. 1000 m)	6XV1830-8AH10
Push-pull cable connector for 1L+/2L+, not pre-assembled	6GK1907-0AB10-6AA0
Push-pull cable connector for RJ45, not pre-assembled	6GK1901-1BB10-6AA0
Caps for push-pull sockets (1L+/2L+), 5 items per package, 1 item	6ES7194-4JA50-0AA0
Caps for push-pull sockets RJ45, 5 items per package, 1 item	6ES7194-4JD50-0AA0
PROFINET/Ethernet standard cable 2x2, Type A, unassembled; minimum order quantity 20 m	6XV1840-2AH10
Accessories for RFID	
SLG cable MOBY U; 2 m	6GT2091-0FH20
SLG cable MOBY U; 5 m	6GT2091-0FH50
SLG cable MOBY D; 2 m	6GT2691-0FH20
Reader cable RF300, extension cable RF300 / RF600 / MOBY I / E / U / D; 2 m	6GT2891-0FH20
Reader cable RF300, extension cable RF300 / RF600 / MOBY U / D; 5 m	6GT2891-0FH50
Reader cable RF300, extension cable RF300 / RF600 / MOBY U / D; 10 m	6GT2891-0FN10
Reader cable RF300, extension cable RF300 / RF600 / MOBY U / D; 20 m	6GT2891-0FN20
Reader cable RF300, extension cable RF300 / RF600 / MOBY U / D; 50 m	6GT2891-0FN50
Reader cable for RF300; connector on the reader is angled; 2 m	6GT2891-0JH20
RFID CD "Software&Documentation"	6GT2080-2AA10

1) These cables are available in different lengths. See Catalog IK PI for more details

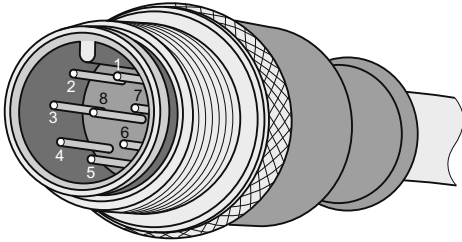
Command and acknowledgement telegrams

A

In this Section, you will find detailed information on some commands mentioned in Section Communication interface (Page 49). Only those commands requiring a special coding of commands and results are described.

Note

Special information on telegram expansions for the RF620R/RF630R readers can be found in the Appendix of the "Configuration Manual RF620R/RF630R".

RESET

Command telegram
to MOBY-ASM

standby	Param	00	dili	multitag	fcon	ftim
---------	-------	----	------	----------	------	------

Maximum number of tags being processed in parallel in the field; permissible values: 00 01 hex

MOBY U:
field_ON_control (see input parameter)
BERO operating mode
00 hex = without BEROs; no write/read device synchronization
01 hex = field_ON_time switches the field off
02 hex = 1st BERO switches the field on; 2. BERO switches the field off
03 hex = write/read device synchronization via cable connection activated (see manual for configuring, mounting and service for MOBY U)

MOBY D, RF300 not used (00 hex)

MOBY U:
distance_limiting_ (see input parameters)
05; 0A; 0F; 14; 19; 1E; 23 hex = 0.5; 1.0; 1.5; 2.0; 2.5; 3.0; 3.5 m
85; 8A; 8F; 94; 99; 9E; A3 hex = ditto with reduced output power

MOBY D: HF rating (see input parameters)
can only be set in 0.25 W steps for SLG D10S
02 hex = 0.5 W ... 10 hex = 4 W (default) ... 28 hex = 10 W

RF300:
distance_limiting only for RF380R change of output power
02 hex = 0.5 W 06 hex = 1.5 W
03 hex = 0.75 W 07 hex = 1.75 W
04 hex = 1.0 W 08 hex = 2.0 W
05 hex = 1.25 W

Option 1: MOBY RF300 only

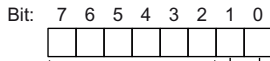

1 = reset ERR LED on the write/read device
0 = do not reset ERR LED on the write/read device

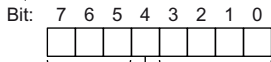

Presence check and MDS control (MDS_control_)
000 = no presence check
001 = no MDS control; presence check via firmware (default)

MOBY U:
field_ON_time_ (see input parameters)
00 hex = without BEROs
01 hex ... FF hex = 1 ... 255 s ON duration for the write/read device field

MOBY D:
MDS type (see input parameters)
00 hex = I code 1 (e.g. MDS D139)
01 hex = ISO-MDS
02 hex = (dual-driver, ICode1 and ISO)
03 hex = (MDS D324 optimization, only for write/read device D10S)
04 hex = (MDS D4xx optimization, only for write/read device D11S/12S)

RF300:
field_ON_time (see input parameters)
00 hex = RF300 mode (no ISO)
01 hex = Manufacturer-independent tag
03 hex = ISO my-d (Infineon SRF 55V10P)
04 hex = ISO (Fujitsu MB89R118)
05 hex = ISO I-Code SLI (NXP SL2 ICS20)
06 hex = ISO Tag-it HFI (Texas Instruments)
07 hex = ISO (ST LRI2K)

MOBY U:
scanning_time_; standby time for the MDS (see input parameters)
00 hex = no standby mode
01 hex ... C8 hex = 7 ms ... 1400 ms standby time

MOBY D, RF300: not used (00 hex)

GetReaderStatus mode = 01

Result message frame
mode = 01

01	SLG status
----	------------

The meaning of the SLG status
is described in the following table

Byte	0	1	2	3	4	5	6	7	8	9	10	11	12	13	14	15	16	17
Param	S-Info	HW	HW-V		LD-V	FW		FW-V		TR		TR-V		INT	baud	res	res	

Byte	18	19	20	21	22	23	24	25	26	27	
Param	res	dili	multi	fcon	fon	sync	ant	stand_by	MDS control		

Parameter name	Comment
S-Info	Reader status mode information = 01
HW	Hardware type
HW-V	Hardware version
LD-V	Version of loader
FW	Firmware type
FW-V	Firmware version
TR	Driver type
TR-V	Version of driver
INT	Interface (RS 232/RS 422)
Baud	Baud rate
Dili	Range-capacity setting
multi	Multitag reader
fcon	field_ON_control: BERO mode (RF300: res)
fon	Field_on_time: <ul style="list-style-type: none"> • MOBY U: BERO time • MOBY D: Tag type • RF300-ISO: Tag type
sync	Semaphore control (synchronization with reader (RF300: res)
ant	Status of antenna
stand_by	Time of standby after command execution (RF300: res)
MDS control	Presence mode

For detailed information, please refer to the respective reader description.

GetReaderStatus mode = 02

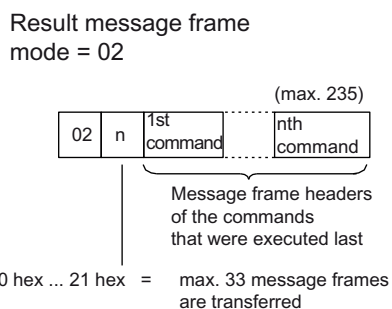

GetReaderStatus mode = 03

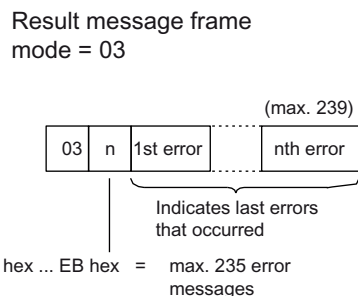

GetReaderStatus mode = 04

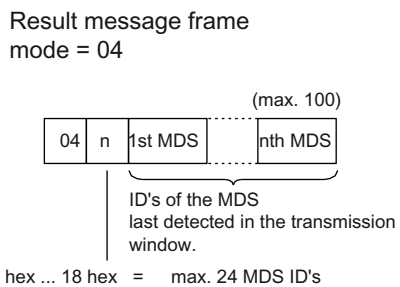

GetReaderStatus mode = 05

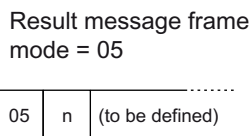

GetReaderStatus mode = 06

Result message frame
mode = 06

06	Diagnostic data
----	-----------------

The meaning of the diagnostics data is described in the following table

Byte	0	1	2	3	4	5	6	7	8 ... 26
Param	S-Info	FZP	ABZ	CFZ	SFZ	CRCFZ	BSTAT	ASMFZ	res.

Parameter name	Comment
S-Info	Reader status mode information = 06
FZP	Error counter, passive (errors during idle time)
ABZ	Abort counter
CFZ	Code error counter
SFZ	Signature error counter
CRCFZ	CRC error counter
BSTAT	Current command status
ASMFZ	Interface error counter for ASM
res.	Spare

GetReaderStatus mode = 07

Result message frame
mode = 07

07	SLG status
----	------------

The meaning of the SLG status is described in the following table

Byte	0	1	2	3	4	5	6	7	8	9	10	11	12	13	14	15	16	17
Param	S-Info	HW	HW-V		res0		FW		FW-V		TR		H	Min.	Sec	res1	SLG-V	Baud

Byte	18	19	20	21	22	23	24	25	26	
Param	res2	dili_SLG	multi	field_on_control	field_on_time	expert	ant	scanning_time	MDS control	

Parameter name	Comment
S-Info	Reader status mode information = 07
HW	Hardware type
HW-V	Hardware version
res0	Reserved
FW	Firmware type
FW-V	Firmware version
TR	Driver type
H	hours
Min.	Minutes
Sec	Seconds
res1	Reserved
SLG-V	Reader version
Baud	Baud rate
res2	Reserved
dili_SLG	Set transmission performance
multi	Multitag reader
field_on_control	Set communication type
field_on_time	Set channel
expert	Expert mode
ant	Status of antenna
scanning_time	Radio communication profile
MDS control	Presence mode

For detailed information, please refer to the respective reader description.

GetTagStatus mode = 00

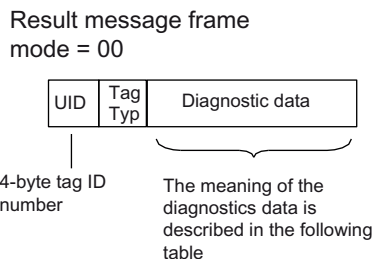

Byte	0	1	2	3	4	5	6	7	8	9	10	11	12	13	14	15
Param	UID				MDS_type	sum_sub			sum_search		week	Year	battery		ST	

Parameter name	Comment
UID	UID (tag number, EPC ID)
MDS_type	MDS type
sum_sub	Sum of subframe access
sum_search	Sum of searchmode
week	Date of last sleep-time change (week of year)
Year	Date of last sleep-time change (year)
battery	Battery left (percentage)
ST	Set sleep-time value on MDS

For detailed information, please refer to the respective reader description.

GetTagStatus mode = 01

Result message frame
mode = 01

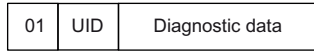

8-byte tag ID number (unique identifier)
The meaning of the diagnostics data is described in the following table

Byte	0	1	2	3	4	5	6	7	8	9	10 ... 15	
Param	status	UID 1 4			UID 5 8				Lock_state	res.		

Parameter name	Comment
status	Tag status mode information = 01
UID 1 4	UID (tag number, EPC ID)
UID 5 8	
Lock_state	EEPROM write protection status
res.	Spare

For detailed information, please refer to the respective reader description.

GetTagStatus mode = 02

Result message frame
mode = 02

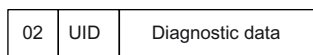

The meaning of the diagnostics data is described in UDT 270

Byte	0	1	2	3	4	5	6	7	8	9	10	11	12 ... 15
Param	status	UID 1 4			UID 5 8			LFD	FZP	FZA	res.		

Parameter name	Comment
status	Tag status mode information = 02
UID 1 4	UID (tag number, EPC ID)
UID 5 8	
LFD	Relationship between power flow density limit and actual measured value
FZP	Error counter, passive (errors during idle time)
FZA	Error counter, active (errors during communication)
ANWZ	Presence error
res.	Spare

GetTagStatus mode = 03

Result message frame
mode = 03

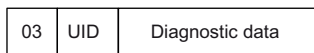

The meaning of the diagnostics data is described in the RF300 System Manual

Byte	0	1	2	3	4	5	6	7	8	9	10	11	12	13	14
Param	status	UID 1 4			UID 5 8				IC_version	Size		lock_state	block_size	nr_of_blocks	

Parameter name	Comment
status	Tag status mode information = 02
UID 1 4	UID (tag number)
UID 5 8	always 0
IC_version	Chip version (for my-d = 00h)
Size	Memory size in bytes
lock_state	Lock status, OTP information: per block (4x4 bytes or 2x8 bytes) one bit (bit=1: block is locked)
block_size	Block size of the transponder
nr_of_blocks	Number of blocks

For detailed information, please refer to the respective reader description.

GetTagStatus mode = 04

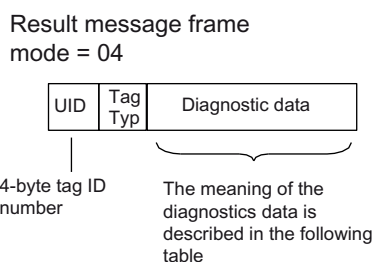

Byte	0	1	2	3	4	5	6	7	8	9	10	11	12	13	14	15	16
Param	status	UID 1 4			UID 5 8				ant	RSSI	H	Min.	Sec	res	res1	res2	

Parameter name	Comment
status	Tag status mode information = 04
UID 1 4	UID (tag number, EPC ID)
UID 5 8	
ant	Antenna that has detected the MDS
RSSI	RSSI threshold value
H	hours
Min.	Minutes
Sec	Seconds
res	Spare
res1	Spare
res2	Spare

For detailed information, please refer to the respective reader description.

Addressing of the RFID tags

Address space of the MDS versions for MOBY U

Table B- 1 Address space MOBY U

Memory	Addressing	16-bit hexadecimal number	Integer number
2 KB data memory	Start address	0000	+0
	End address	07FF	+2047
	Memory size	08 00	2048
	Read OTP memory (write access only possible once. The OTP memory of MOBY U can only be processed completely, i.e. the start address must always be specified with value FFF0 hex and the length with value 10 hex.)		
	Start address	FFF0	-16
	Length	10	+16
ID No.: (4 fixed-coded bytes; can only be read with the MDS status command)			
32 KB data memory	Start address	0000	+0
	End address	7FFF	+32767
	Memory size	80 00	32768
	Read OTP memory (write access only possible once)*		
	Start address	FFF0	-16
	Length	10	+16
ID No.: (4 fixed-coded bytes; can only be read with the MDS status command)			

Address space of the MDS versions for MOBY D

For address space of the RF300 transponders, see MOBY D System Manual (<http://support.automation.siemens.com/WW/view/en/13628689/0/en>), section "Mobile data storage units > Introduction".

Address space of the transponder versions for RF300

For address space of the RF300 transponders, see SIMATIC RF300 System Manual (<http://support.automation.siemens.com/WW/view/en/21738946/0/en>), section "RF300 transponders > Memory configuration of the RF300 tags" and section "ISO transponders > Memory configuration of the ISO tags".

Address space of the transponder versions for RF600

For address space of the RF600 transponders, see SIMATIC RF620R/RF630R Parameterization Manual

(<http://support.automation.siemens.com/WW/view/de/33287195/0/en>), section "Examples/applications > Memory configuration".

Transfer scheme for hexadecimal tag data via XML

The addresses for memory addressing on the tag are hexadecimal. The data on the tag is also stored in hexadecimal format. However, with the read/write commands, the data is transferred as ASCII characters. Conversion from hex to ASCII hex and vice versa is executed automatically in the communication module. The following example shows the coding scheme:

Command to RF182C

```
<readTagData>
  <startAddress>0000</startAddress>
  <dataLength>0004</dataLength>
</readTagData>
```

Data in tag

Address [hex]	Data [hex]	Data [ADC]
0000	4D	'M'
0001	4F	'O'
0002	42	'B'
0003	59	'Y'
...		

Result of the RF182C

```
<readTagData>
<returnValue>
  <data>4D4F4259</data>
</returnValue>
</readTagDatat>
```

Optional: storage of the result data in the data block of a controller

Address [dec]	Data [hex]	Data [ASC]
N	24	,4'
N+1	44	'D'
N+2	34	,4'
N+3	46	'F'
N+4	34	,4'
N+5	32	,2'
N+6	35	,5'
N+7	39	,9'

Service & support

Technical support

The technical support specialists advise and assist customers by responding to their queries on the functions of our RFID products and how to work with them.

You can reach us worldwide Mon. to Fri. during office hours: 8 a.m. - 5 p.m. CET:

Telephone: ++49 (0) 180 5050-222

Fax: ++49 (0) 180 5050-223

Internet

Visit our site on the Internet at:

Support homepage (www.siemens.com/automation/service&support)

You can send a support query to:

Online support request form: (www.siemens.com/automation/support-request)

General information on new features of the RF182C communication module and an overview of our other identification systems can be found on the Internet at:

RFID homepage (www.siemens.com/simatic-sensors/rf)

