

SIEMENS

SIRIUS

DE Kompaktmodul K60
 EN Compact Module K60
 FR Module compact K60

ES Módulo compacto K60
 IT Modulo compatto K60
 PT Módulo compacto K60

TR Kompakt modül K60
 PY Компактный модуль K60
 中文 紧凑型模块 K60

3RK1..
 3RK2..

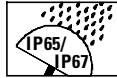
Technical Assistance:







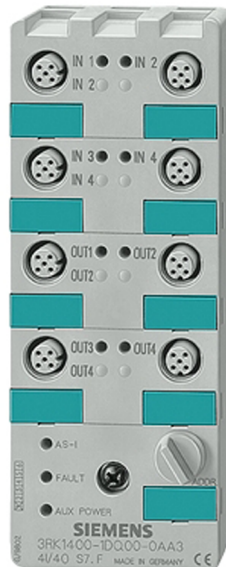

Telephone: +49 (911) 895-5900 (8°° - 17°° CET)
 Fax: +49 (911) 895-5907
 E-mail: technical-assistance@siemens.com
 Internet: www.siemens.com/industrial-controls/technical-assistance

SIEMENS AG
Technical Assistance
 Würzburger Str. 121
 D-90766 Fürth

Betriebsanleitung DE
 Operating Instructions EN
 Instructions de service FR
 Instructivo ES
 Istruzioni operative IT
 Instruções de Serviço PT
 İşletme Kılavuzu TR
 Руководство по эксплуатации PY
 使用说明 中文

3RK1100-1CQ00-0AA3 (K60 4DO)	3RK1400-1BQ00-0AA3 (K60 2DI/2DO)	3RK2100-1CQ00-0AA3 (K60 4DO)	3RK2400-1DQ00-0AA3 (K60 4DI/4DO A/B)
3RK1200-0CQ00-0AA3 (K60 4DI)	3RK1400-1DQ00-0AA3 (K60 4DI/4DO)	3RK2200-0CQ00-0AA3 (K60 4DI A/B)	3RK2400-1DQ00-1AA3 (K60 4DI/4DO A/B)
	3RK1400-1DQ01-0AA3 (K60 4DI/4DO)		3RK2400-1FQ03-0AA3 (K60 4DI/3DO A/B)
	3RK1400-1DQ02-0AA3 (K60 4DI/4DO)		
	3RK1400-1MQ00-0AA3 (K60 4DI/2DO)		



DE	 VORSICHT	Eine sichere Gerätefunktion ist nur mit zertifizierten Komponenten gewährleistet.
EN	 CAUTION	Reliable functioning of the equipment is only ensured with certified components.
FR	 PRUDENCE	La sécurité de fonctionnement de l'appareil n'est garantie qu'avec des composants certifiés.
ES	 PRECAUCIÓN	El funcionamiento seguro del aparato sólo está garantizado con componentes certificados.
IT	 CAUTELA	Il funzionamento sicuro dell'apparecchiatura è garantito soltanto con componenti certificati.
PT	 CUIDADO	O funcionamento seguro do aparelho apenas pode ser garantido se forem utilizados componentes certificados!
TR	 ÖNEMLİ DİKKAT	Cihazın güvenli çalışması ancak sertifikalı bileşenler kullanılması halinde garanti edilebilir.
PY	 OCTOPOЖHO	Безопасность работы устройства гарантируется только при использовании сертифицированных компонентов.
中文	 小心	只有认证的部件才能保证设备可靠发挥作用。

DE	Montage / Verdrahtung	ES	Montaje / Cableado	TR	Montaj / Kablo bağlantısı
EN	Installation / Wiring	IT	Montaggio / Cablaggio	PY	Монтаж / электропроводка
FR	Montage / Câblage	PT	Montagem / Cablagem	中文	就任 // 线路

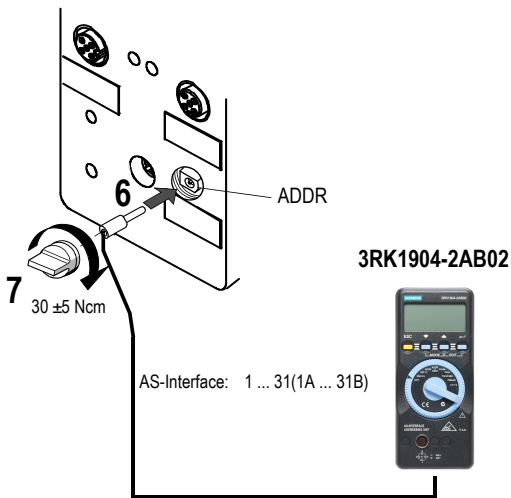
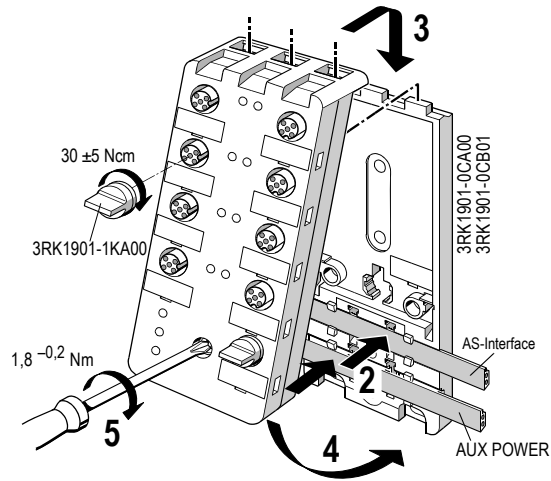
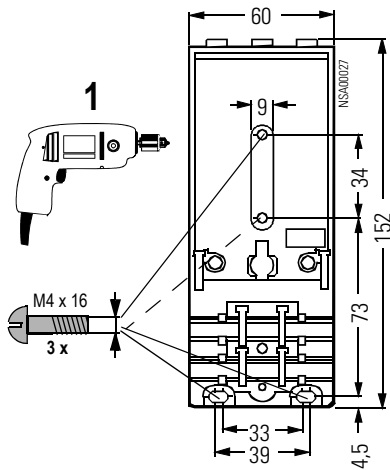

DE	Adressen einstellen
EN	Setting addresses
FR	Réglage de l'adresse
ES	Ajustar dirección
IT	Indirizzamento
PT	Ajustar endereço
TR	Adresleri ayarlama
PY	Настройка адресов
中文	设置地址

DE	Logische Zuordnung	ES	Asignación lógica	TR	Mantıksal atama
EN	Logic assignments	IT	Assegnazione logica	PY	Логическое присваивание
FR	Affectation logique	PT	Atribuição lógica	中文	逻辑分配

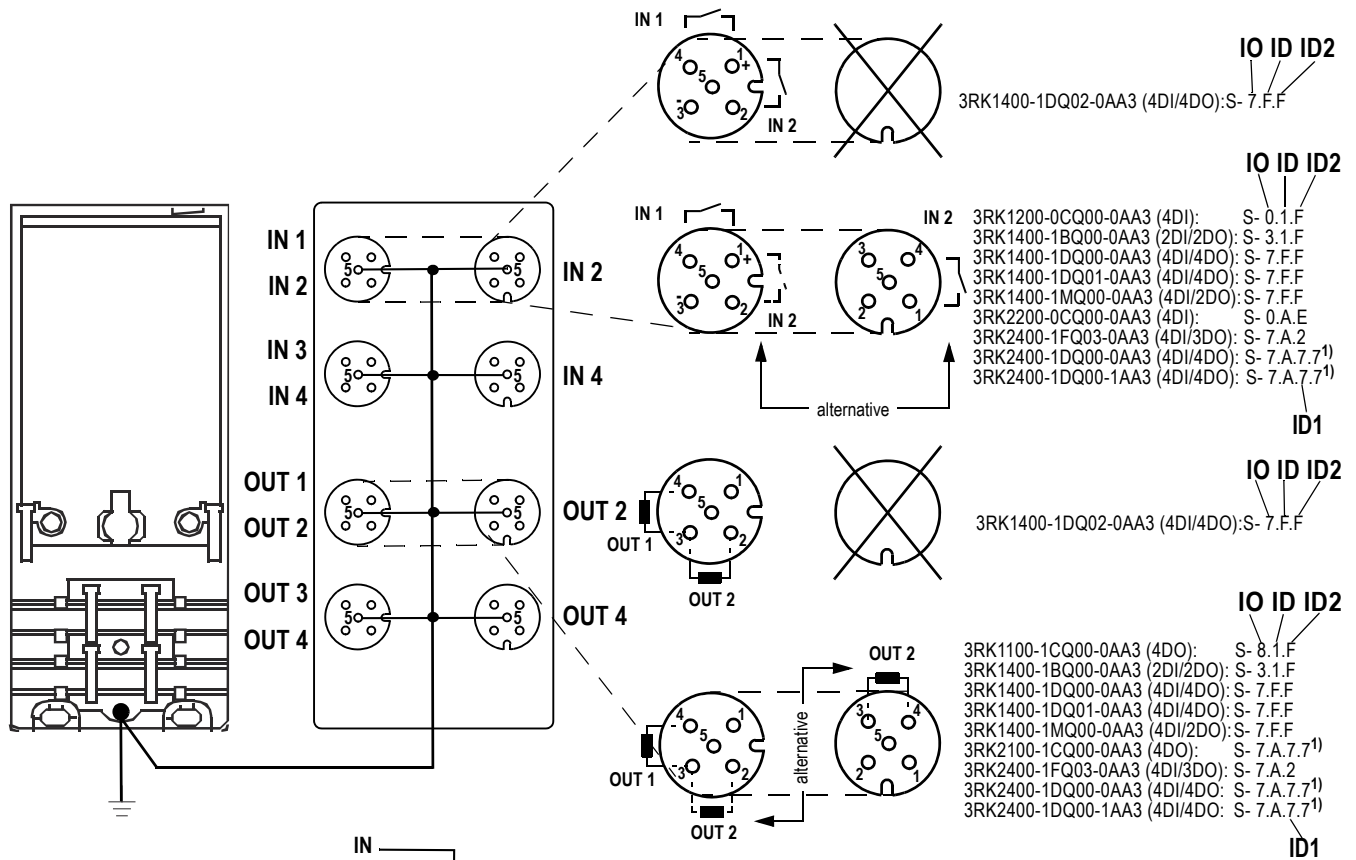













DE	nur mit	M4 AS-Interface Master
EN	only	
FR	seulement	
ES	solo	
IT	solo	
PT	somente	
TR	sadece	
PY	только	
中文	仅针对	

DE	Logische Zuordnung - Ein- / Ausgänge	ES	Asignación lógica: Entradas/salidas	TR	Mantıksal atama Giriş/çıkışlar
EN	Logic assignment - Inputs/outputs	IT	Assegnazione logica di ingressi e uscite	PY	Логическое назначение Вход/Выход
FR	Affectation logique Entrées / sorties	PT	Atribuição lógica Entradas e saídas	中文	逻辑分配 - 输入 / 输出端

	3RK1100-... 3RK2100-...	3RK1200-... 3RK2200-...	3RK1400-1BQ00-0AA3	3RK1400-1MQ00-0AA3	3RK1400-... 3RK2400-.DQ00-.AA3	3RK2400-1FQ03-0AA3
IN1	—	D0	D0	D0	D0	D0
IN2	—	D1	D1	D1	D1	D1
IN3	—	D2	—	D2	D2	D2
IN4	—	D3	—	D3	D3	D3
OUT1	D0	—	D0	D0	D0	D0
OUT2	D1	—	D1	D1	D1	D1
OUT3	D2	—	—	—	D2	D2
OUT4	D3	—	—	—	D3	—

DE	Status LEDs	ES	LEDs de estado	TR	Durum LED'leri
EN	Status LEDs	IT	LED di stato	РУ	СИДЫ состояния
FR	LED d'état	PT	LEDs de estado	中文	LED 状态

				3RK1100-.. 3RK1200-.. 3RK1400-.. 3RK2100-.. 3RK2200-.. 3RK2400-..	3RK1200-.. 3RK2200-.. 3RK1400-.. 3RK2400-1DQ00-.. 3RK2400-1FQ03-..	3RK1100-.. / 3RK2100-.. 3RK2400-.. 3RK1400-1DQ02-0AA3 3RK1400-1DQ00-0AA3 3RK1400-1DQ01-0AA3 3RK1400-1MQ00-0AA3
Betriebszustand	Kommunikation in Ordnung	Keine Spannung am AS-Interface-Chip	Kommunikation ausgefallen	Slave hat Adresse "0"	Überlast Sensorversorgung	Überlast / Kurzschluss am Ausgang (Peripheriefehler)
Operating state	Communication OK	No voltage present at AS Interface chip	Communication failed	Slave has address "0"	Overload of sensor supply	Overload / short-circuit in output terminal (Periphery fault)
Etat	Communication O.K.	ASIC AS-Interface non alimenté	Communication perturbée	Esclave avec adresse "0"	Surcharge alimentation des capteurs	Surcharge / court-circuit en sortie (erreur en périphérie)
Estado de servicio	La comunicación esta O.K.	No hay tensión en el chip AS-Interface	Falla la comunicación	El esclavo tiene dirección "0"	Sobrecarga en la alimentación de los sensores	Sobrecarga / cortocircuito en la salida (error de periferia)
Stato di funzionamento	Comunicazione in ordine	Manca tensione su chip AS-Interface	Comunicazione interrotta	Slave ha indirizzo "0"	Sovraccarico alimentazione sensorio	Sovraccarico / cortocircuito sull'uscita (errore di periferia)
Estado de funcionamento	Comunicação em ordem	Nenhuma tensão no chip AS-Interface	Falha na comunicação	O escravo tem endereço "0"	Sobrecarga na alimentação do sensor	Sobrecarga / curto-circuito na saída (erro periférico)
İşletme durumu	İletişim iyi durumda	AS arabirim çipinde gerilim yok	İletişim kesildi	Slave adresi: "0"	Gerilim beslemesinde aşırı yük	Çıkışta aşırı yük / kısa devre (çevre birim hatası)
Рабочее состояние	Связь в порядке	На AS-интерфейсе нет напряжения	Связь Прервалась	Адрес исполнительного модуля: "0"	Перегрузка цепи питания датчиков	Перегрузка / короткое замыкание на выходе (неисправность периферии)
运行状态	通信正常	AS-i 接口芯片上无电压	通信故障	从站地址为 "0"	传感器电源过载	输出端过载 / 短路 (外围设备故障)
AS-i (grün) AS-i (green) AS-i (verte) AS-i (verde) AS-i (verde) AS-i (verde) AS-i (yeşil) AS-i (зеленый) AS-i (绿色)						
FAULT (rot) FAULT (red) FAULT (rouge) FAULT (rojo) FAULT (rosso) FAULT (vermelho) FAULT (kırmızı) FAULT (красный) FAULT (红色)						
3RK1100-.. / 3RK1400-.. / 3RK2100-.. / 3RK2400-.. Betriebszustand Ein / Operating state On / Etat actives / Estado de servicio activada / Stato di funzionamento on / Estado de funcionamento ligado / İşletme durumu Açık / Рабочее состояние / 运行状态 接通						
AUX POWER		grün / green / verte / verde / verde / verde / yeşil / зеленый / 绿色				

DE	Weitere Daten und Bestellnummern für Zubehör siehe Katalog.	ES	Para más datos y el N° de referencia para accesorios, v. Catálogo.	TR	Diğer veriler ve aksesuarların sipariş numarası için kataloga bakın.
EN	For further data and accessories see Catalog.	IT	Per altri dati e per le sigle di ordinazione degli accessori vedere il catalogo.	РУ	Дополнительные данные и номера заказа комплектующих смотри Каталог.
FR	Pour de plus amples informations et pour les accessoires, voir Catalogue.	PT	Para outros dados e número de encomenda para os acessórios, consulte o Catálogo.	中文	详细数据和配件订货号请参阅目录。