



**Allen-Bradley**

# **1336 IMPACT™ Adjustable Frequency AC Drive**

**0.37 - 597 kW (0.5 - 800 HP)  
Version 1.xx - 4.xx**

**User Manual**

**Rockwell  
Automation**

## Important User Information

Solid state equipment has operational characteristics differing from those of electromechanical equipment. “*Safety Guidelines for the Application, Installation and Maintenance of Solid State Controls*” (Publication SGI-1.1 available from your local Allen-Bradley Sales Office or online at <http://www.ab.com/manuals/gi>) describes some important differences between solid state equipment and hard-wired electromechanical devices. Because of this difference, and also because of the wide variety of uses for solid state equipment, all persons responsible for applying this equipment must satisfy themselves that each intended application of this equipment is acceptable.

In no event will the Allen-Bradley Company be responsible or liable for indirect or consequential damages resulting from the use or application of this equipment.

The examples and diagrams in this manual are included solely for illustrative purposes. Because of the many variables and requirements associated with any particular installation, the Allen-Bradley Company cannot assume responsibility or liability for actual use based on the examples and diagrams.

No patent liability is assumed by Allen-Bradley Company with respect to use of information, circuits, equipment, or software described in this manual.

Reproduction of the contents of this manual, in whole or in part, without written permission of the Allen-Bradley Company is prohibited.

Throughout this manual we use notes to make you aware of safety considerations.



**ATTENTION:** Identifies information about practices or circumstances that can lead to personal injury or death, property damage, or economic loss.

---

Attentions help you:

- identify a hazard
- avoid the hazard
- recognize the consequences

**Important:** Identifies information that is especially important for successful application and understanding of the product.



**Shock Hazard** labels may be located on or inside the drive to alert people that dangerous voltage may be present.

---

SCANport is a trademark of Rockwell Automation.

PLC is a registered trademark of Rockwell Automation.

COLOR-KEYED is a registered trademark of Thomas & Betts Corporation.

IBM is a registered trademark of International Business Machines Corporation.

Windows 95 is a registered trademark of Microsoft Corporation.

	Who Should Use this Manual? . . . . .	1-1
	What Is the 1336 IMPACT Drive? . . . . .	1-1
	Purpose of this Manual . . . . .	1-1
	Terms and Abbreviations . . . . .	1-3
	Common Techniques Used in this Manual . . . . .	1-5
	Allen-Bradley Support . . . . .	1-5
	<b>Chapter 1</b>	
<b>Overview</b>	Chapter Objectives . . . . .	1-1
	What Features Does the 1336 IMPACT Drive Provide? . . . . .	1-1
	How Do I Read the Catalog Number? . . . . .	1-3
	What is a Frame Designator? . . . . .	1-4
	Hardware Overview . . . . .	1-5
	Where Do I Go From Here? . . . . .	1-6
	<b>Chapter 2</b>	
<b>Mounting and Wiring Your 1336 IMPACT Drive</b>	Chapter Objectives . . . . .	2-1
	Before Mounting Your Drive . . . . .	2-2
	Input Fuses and Circuit Breakers . . . . .	2-5
	Mounting Your Drive . . . . .	2-10
	Grounding Your Drive . . . . .	2-14
	Wiring the Power . . . . .	2-17
	Hard Wiring Your I/O . . . . .	2-21
	Connecting Your Gateway . . . . .	2-24
	Installing an Interface Board . . . . .	2-25
	Connecting the Power to the Drive . . . . .	2-25
	Disconnecting the Drive Output . . . . .	2-27
	Starting and Stopping the Motor . . . . .	2-27
	Electrical Interference — EMI/RFI . . . . .	2-28
	Do I Need an RFI Filter? . . . . .	2-28
	<b>Chapter 3</b>	
<b>Mounting and Wiring Information Specific to Frames A1, A2, A3, and A4</b>	Chapter Objectives . . . . .	3-1
	Wiring the Power . . . . .	3-1
	Hard Wiring Your I/O . . . . .	3-3
	Input Fusing Requirements . . . . .	3-4
	Dimensions . . . . .	3-5
	<b>Chapter 4</b>	
<b>Mounting and Wiring Information Specific to Frames B, C, D, E, F, G, &amp; H</b>	Chapter Objectives . . . . .	4-1
	Wiring the Power . . . . .	4-1
	Selecting the Proper Lug Kit for Your System . . . . .	4-6
	Hard Wiring Your I/O . . . . .	4-8
	Selecting/Verifying Fan Voltage . . . . .	4-10
	Input Fusing Requirements . . . . .	4-11
	Dimensions . . . . .	4-12
	<b>Chapter 5</b>	
<b>Using the L Option</b>	Chapter Objectives . . . . .	5-1
	What is the L Option? . . . . .	5-2
	What Functions are Available? . . . . .	5-3

	Setting Up the L Option Board . . . . .	5-4
	Using an Encoder with the L Option Board . . . . .	5-11
	Requirements for the Contact Closure Interface Board (L4). . . . .	5-11
	Requirements for the 24V AC/DC Interface Board Requirements (L5) . . . . .	5-12
	Requirements for the 115V AC Interface Board (L6) . . . . .	5-13
	Requirements for the Contact Closure Interface Board (L7E) . . . . .	5-14
	Requirements for the 24V AC/DC Interface Board Requirements (L8E) . . . . .	5-15
	Requirements for the 115V AC Interface Board (L9E) . . . . .	5-16
	<b>Chapter 6</b>	
<b>Starting Up Your System</b>	Chapter Objectives . . . . .	6-1
	Before Applying Power to Your Drive . . . . .	6-1
	Applying Power to Your Drive . . . . .	6-3
	Recording Your Drive and Motor Information . . . . .	6-3
	Understanding the Basics of the Human Interface Module (HIM). . . . .	6-4
	Starting Up Your System . . . . .	6-7
	Running the Quick Motor Tune Procedure . . . . .	6-8
	Configuring the Digital Section . . . . .	6-10
	Configuring the Analog Section . . . . .	6-11
	Understanding Links . . . . .	6-12
	Where Do I Go From Here? . . . . .	6-14
	<b>Chapter 7</b>	
<b>Setting Up the Input/Output</b>	Chapter Objective . . . . .	7-1
	What Are Drive Units? . . . . .	7-1
	Setting Up the Analog I/O . . . . .	7-1
	Setting Up the 4 – 20 mA Input/Output . . . . .	7-8
	Using the SCANport Capabilities . . . . .	7-10
	Configuring the Output Relay . . . . .	7-10
	Configuring the Pulse Input. . . . .	7-11
	Configuring the L Option I/O . . . . .	7-12
	<b>Chapter 8</b>	
<b>Using the SCANport Capabilities</b>	Chapter Objectives . . . . .	8-1
	Understanding the Logic Input Sts Parameter . . . . .	8-1
	SCANport Definition . . . . .	8-1
	Configuring the SCANport Controls . . . . .	8-3
	Setting the SCANport Faults. . . . .	8-7
	Using the SCANport I/O Image. . . . .	8-8
	Setting Up the Analog I/O Parameters for SCANport . . . . .	8-14
	<b>Chapter 9</b>	
<b>Applications</b>	Chapter Objectives . . . . .	9-1
	Choosing a Motor Feedback Source . . . . .	9-1
	Choosing an Optional Braking/Decelerating Method . . . . .	9-3
	Using DC Hold . . . . .	9-6
	Using Up to 400% Motor Current . . . . .	9-7
	Understanding the Scale and Offset Parameters for Analog I/O . . . . .	9-8
	Using 4 – 20 mA Inputs/Outputs . . . . .	9-11
	Using a Remote Pot . . . . .	9-12
	Using MOP . . . . .	9-14
	Using Flying Start . . . . .	9-14
	Speed Profiling Introduction . . . . .	9-16
	Speed Profiling Operation. . . . .	9-17

	Speed Profile Start Up Configuration . . . . .	9-18
	Initial Setup Requirements . . . . .	9-19
	Profile Command & Control . . . . .	9-21
	Using the TB3 Inputs . . . . .	9-23
	Encoder Steps . . . . .	9-25
	 <b>Chapter 10</b>	
<b>Using the Function Block</b>	Chapter Objectives . . . . .	10-1
	What is a Function Block? . . . . .	10-1
	Evaluating the Inputs . . . . .	10-4
	Using the Timer Delay Function . . . . .	10-5
	Using the State Machine Function . . . . .	10-8
	Using the Add/Subtract Function . . . . .	10-10
	Using the Maximum/Minimum Function . . . . .	10-12
	Using the Up/Down Counter Function . . . . .	10-14
	Using the Multiply/Divide Function . . . . .	10-18
	Using the Scale Function . . . . .	10-20
	Using the Hysteresis Function . . . . .	10-23
	Using the Band Function . . . . .	10-26
	Using the Logical Add/Subtract Function . . . . .	10-26
	Using the Logical Multiply/Divide Function . . . . .	10-27
	 <b>Chapter 11</b>	
<b>Parameters</b>	Chapter Objectives . . . . .	11-1
	Understanding the Parameter Files and Groups . . . . .	11-1
	Numerical Parameter Listing . . . . .	11-5
	Alphabetical Parameter Listing . . . . .	11-7
	Parameter Conventions . . . . .	11-9
	 <b>Chapter 12</b>	
<b>Troubleshooting</b>	Chapter Objectives . . . . .	12-1
	Required Equipment . . . . .	12-1
	Fault/Warning Handling . . . . .	12-2
	Viewing the Fault and Warning Queues on the HIM . . . . .	12-6
	What Are the Fault Descriptions? . . . . .	12-7
	Understanding Precharge and Ridethrough Faults . . . . .	12-16
	Understanding the Bus Voltage Tracker . . . . .	12-21
	Understanding the Parameter Limit Faults . . . . .	12-22
	Understanding the Math Limit Faults . . . . .	12-24
	Start Up Troubleshooting Procedures . . . . .	12-27
	Miscellaneous Troubleshooting Procedures . . . . .	12-28
	Encoderless Troubleshooting Problems . . . . .	12-30
	 <b>Chapter 13</b>	
<b>Understanding the Auto-tuning Procedure</b>	Chapter Objectives . . . . .	13-1
	What Is Auto-tuning? . . . . .	13-1
	Running the Power Structure and Transistor Diagnostics Tests . . . . .	13-2
	Running the Phase Rotation Test . . . . .	13-5
	Running the Sequential Torque Tuning Tests . . . . .	13-6
	Running the Inertia Test . . . . .	13-9
	Checking the Auto-tune Status . . . . .	13-13

---

	<b>Appendix A</b>	
<b>Specifications</b>	Chapter Objectives . . . . .	A-1
	Specifications . . . . .	A-1
	Input/Output Ratings . . . . .	A-4
	Cable and Wiring Recommendations . . . . .	A-5
	Software Block Diagram . . . . .	A-6
	<b>Appendix B</b>	
<b>Control Block Diagrams</b>	Chapter Objectives . . . . .	B-1
	Motor Control Board Overview . . . . .	B-2
	Speed Reference Selection Overview . . . . .	B-4
	Trim Control Overview . . . . .	B-10
	Speed Feedback Overview . . . . .	B-13
	Speed PI Regulator Overview . . . . .	B-16
	Torque Reference Overview . . . . .	B-19
	Torque Block Overview . . . . .	B-24
	Drive Fault Detection Overview . . . . .	B-27
	Inverter Overload Overview . . . . .	B-32
	Speed Loop Auto-tune Overview . . . . .	B-35
	Through-Put Time . . . . .	B-38
	<b>Appendix C</b>	
<b>Using the Human Interface Module (HIM)</b>	Chapter Objectives . . . . .	C-1
	What Is the Human Interface Module (HIM)? . . . . .	C-1
	HIM Operation . . . . .	C-3
	HIM Compatibility Information . . . . .	C-12
	Removing the HIM . . . . .	C-13
	<b>Appendix D</b>	
<b>Derating Guidelines</b>	Chapter Objectives . . . . .	D-1
	Derating Guidelines . . . . .	D-2
	<b>Appendix E</b>	
<b>CE Conformity</b>	EMC Directive . . . . .	E-1
	Requirements for Conforming Installation . . . . .	E-1
	Filter . . . . .	E-2
	Electrical Configuration . . . . .	E-3
	Grounding . . . . .	E-3
	Mechanical Configuration . . . . .	E-4
	<b>Appendix F</b>	
<b>Spare Parts Information</b>		

## Preface

Read this preface to become familiar with the rest of the manual. This preface covers the following topics:

- who should use this manual
- an overview of the 1336 IMPACT drive
- the purpose of this manual
- terms and abbreviations
- conventions used in this manual
- Allen-Bradley support

### **Who Should Use this Manual?**

Use this manual if you are responsible for installing, wiring, starting, programming, or troubleshooting control systems that use the 1336 IMPACT drive.

This manual is intended for qualified service personnel responsible for setting up and servicing the 1336 IMPACT AC drive. You must have previous experience with and a basic understanding of electrical terminology, programming procedures, required equipment, and safety precautions before attempting to service the 1336 IMPACT drive.

### **What Is the 1336 IMPACT Drive?**

The 1336 IMPACT drive is a high performance, microprocessor-based Field Oriented Control (FOC) AC drive that uses Force technologies™. The 1336 IMPACT drive was designed to be a low cost drive for standalone applications. The drive is user friendly and has an easy to use start up sequence for simple, out of the box installation.

### **Purpose of this Manual**

This manual is a learning and reference guide for the 1336 IMPACT drive. It describes the procedures needed to install, program, start, and maintain the 1336 IMPACT AC drive. Before you operate, service, or initialize the 1336 IMPACT drive, you should, at a minimum read the first 6 chapters of this manual.

## Contents of this Manual

This manual contains the following information:

Chapter	Title	Contents
	Preface	Describes the purpose, background, and scope of this manual as well as an overview of this product.
1	Overview	Provides an overview of the features of the 1336 IMPACT drive. Also provides an overview of the 1336 IMPACT hardware.
2	Mounting and Wiring Your 1336 IMPACT Drive	Provides procedures for mounting and wiring 1336 IMPACT drives. This chapter covers the installation information that is common to all drives.
3	Mounting and Wiring Information Specific to Frames A1, A2, A3, and A4	Provides the mounting and wiring information that is specific to frames A1, A2, A3, and A4.
4	Mounting and Wiring Information Specific to Frames B, C, D, E, F, G, and H	Provides the mounting and wiring information that is specific to frames B, C, D, E, F, G, and H.
5	Using the L Option	Provides information for wiring and using the L Option.
6	Starting Up Your System	Provides procedures for starting up your system.
7	Configuring the I/O Communications	Provides information to help you set up and use the inputs and outputs available on the 1336 IMPACT drive.
8	Using SCANport	Provides information to help you use SCANport™.
9	Applications	Provides information about various applications for which you can use the 1336 IMPACT drive.
10	Using the Function Block	Provides information and examples to help you use the provided function block.
11	Parameters	Provides information about the available parameters.
12	Troubleshooting	Explains how to interpret and correct problems with your drive.
13	Understanding the Auto-tuning Procedure	Provides information to help you solve problems that were reported during the motor tune routine.
A	Specifications	Provides specifications and reference tables for the 1336 IMPACT drive.
B	Control Block Diagrams	Provides information to help you better understand the capabilities of your drive.
C	Using the Human Interface Module (HIM)	Provides information to help you use your Human Interface Module (HIM).
D	Derating Guidelines	Provides the derating graphs for the 1336 IMPACT drive.
E	CE Conformity	Provides information regarding CE conformity.
F	Spare Parts Information	Provides information for locating spare parts.



**ATTENTION:** This board contains ESD (electrostatic discharge) sensitive parts and assemblies. Static control precautions are required when installing, testing, servicing, or repairing this assembly. Component damage may result if you do not follow ESD control precautions. If you are not familiar with static control procedures, refer to *Guarding Against Electrostatic Damage*, Allen-Bradley Publication 8000-4.5.2, or any other applicable ESD protection handbook.

**ATTENTION:** Only personnel familiar with SCANport devices and associated machinery should plan or implement the installation, start-up, or subsequent troubleshooting of this board. Failure to comply may result in personnel injury and/or equipment damage.




## Related Documentation

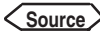

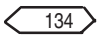

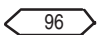

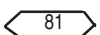

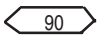

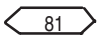

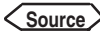

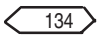

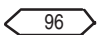

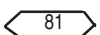

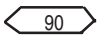

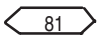

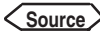

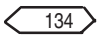

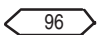

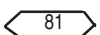

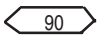

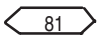


The following documents contain additional information concerning related Allen-Bradley products. To obtain a copy, contact your local Allen-Bradley office or distributor. For the National Electrical Code, you may need to contact the publisher.

For:	Read this document:	Document number:
In-depth information on grounding and wiring Allen-Bradley programmable controllers	Allen-Bradley Programmable Controller Grounding and Wiring Guidelines	1770-4.1
A description on how to install a PLC-5 <sup>®</sup> system	PLC-5 Family Programmable Controllers Hardware Installation Manual	1785-6.6.1
A description of important differences between solid-state programmable controller products and hard-wired electromechanical devices	Application Considerations for Solid-State Controls	SGL-1.1
An article on wire sizes and types for grounding electrical equipment	National Electrical Code	Published by the National Fire Protection Association of Boston, MA.
A complete listing of current Allen-Bradley documentation, including ordering instructions. Also indicates whether the documents are available on CD-ROM or in multi-languages.	Allen-Bradley Publication Index	SD499
A glossary of industrial automation terms and abbreviations	Allen-Bradley Industrial Automation Glossary	AG-7.1

## Terms and Abbreviations

The following terms and abbreviations are specific to this product. For a complete listing of Allen-Bradley terminology, refer to the *Allen-Bradley Industrial Automation Glossary*.

This term:	Has the following definition:
bandwidth	Bandwidth is the frequency range from $\omega = 0$ to the point at which the magnitude response of the speed regulator is 0.707 of (or 3db below) its zero frequency (steady-state) value. The bandwidth indicates the rise time or speed of response of the speed regulator. $\omega = 2\pi f$ , where f is Hz or cycles per second.
destination parameter (read and write parameters)	Destination parameters accept data from other parameters. The drive uses this data to perform the desired functions. An example of a destination parameter is <i>Speed Ref 1</i> (parameter 29), which can accept a speed reference from a device such as a PLC. Throughout this manual, the following symbol indicates a destination parameter: Destination parameters may also be called sink parameters. 
display units	Display units are the units that are displayed on the Human Interface Module (HIM). Display units are units such as Hz, volts, and rpm, and are converted to and from drive units by the HIM.
drive units	Drive units are the actual values of the parameters as stored within the drive parameter table. The drive units are converted to display units that are shown on the Human Interface Module (HIM). Drive units may also be called internal units.
EE or E <sup>2</sup>	See non-volatile memory.
frame size	A single-letter designator used to identify the various drive sizes. Frame sizes are frequently referred to instead of the kW or horsepower rating they represent. Refer to Chapter 1, <i>Overview</i> , to determine the frame size for your drive.

This term:	Has the following definition:																														
links	<p>A link is a software connection between two parameters that lets you transfer data from one parameter to the other. The parameter that provides the information is called the source parameter. The parameter that receives the data is called the destination parameter.</p> <p>The 1336 IMPACT Drive lets you make up to 20 links. You can only program links when the drive is not running. Links are stored in EE and established at power up and/or system reset.</p> <p>There are two types of links:</p> <ul style="list-style-type: none"> <li>• User link — A user link is a software connection that you establish. You can change these links as needed.</li> <li>• Default link — A default link is a software connection between two parameters that is made when the drive is initialized. You can change the default links as needed after initialization. Default links are sometimes called pre-defined links.</li> </ul> <p>The default links are as follows:</p> <table border="0" style="width: 100%; border-collapse: collapse;"> <thead> <tr> <th style="text-align: left;"></th> <th style="text-align: center;"></th> <th style="text-align: center;">To</th> <th style="text-align: center;"></th> <th style="text-align: left;"></th> </tr> </thead> <tbody> <tr> <td>SP An In1 Value</td> <td style="text-align: center;"></td> <td style="text-align: center;">→</td> <td style="text-align: center;">→</td> <td> Speed Ref 1</td> </tr> <tr> <td>An In 1 Value</td> <td style="text-align: center;"></td> <td style="text-align: center;">→</td> <td style="text-align: center;">→</td> <td> Speed Ref 2</td> </tr> <tr> <td>Motor Speed</td> <td style="text-align: center;"></td> <td style="text-align: center;">→</td> <td style="text-align: center;">→</td> <td> An Out 1 Value</td> </tr> <tr> <td>Motor Power</td> <td style="text-align: center;"></td> <td style="text-align: center;">→</td> <td style="text-align: center;">→</td> <td> An Out 2 Value</td> </tr> <tr> <td>Motor Speed</td> <td style="text-align: center;"></td> <td style="text-align: center;">→</td> <td style="text-align: center;">→</td> <td> SP An Output</td> </tr> </tbody> </table> <p>The links are made from the destination side, and the data transfer occurs in the opposite direction.</p> <p>For additional information about links, refer to Chapter 6, <i>Starting Up Your System</i>.</p>			To			SP An In1 Value		→	→	 Speed Ref 1	An In 1 Value		→	→	 Speed Ref 2	Motor Speed		→	→	 An Out 1 Value	Motor Power		→	→	 An Out 2 Value	Motor Speed		→	→	 SP An Output
		To																													
SP An In1 Value		→	→	 Speed Ref 1																											
An In 1 Value		→	→	 Speed Ref 2																											
Motor Speed		→	→	 An Out 1 Value																											
Motor Power		→	→	 An Out 2 Value																											
Motor Speed		→	→	 SP An Output																											
maintained start	<p>With a maintained start, the drive runs as long as you are commanding a start. The drive stops when you remove the start input (for example, if you remove your finger from the start button). This type of start is also referred to as an unlatched start.</p>																														
mask parameters	<p>Through the SCANport interface, up to six different SCANport adapters and the L Option board can control the 1336 IMPACT drive. With this flexibility, conflicts are inherent. The 1336 IMPACT drive lets you make functional masks. At each port, you can selectively lock out functions such as start, jog, and drive direction as well as many fault interlocks by using mask parameters to select the allowable functions for each port.</p>																														
momentary start	<p>With a momentary start, the drive continues running until a stop is commanded, even after you remove the start input. This type of start is also referred to as a latched start.</p>																														
non-volatile memory	<p>Non-volatile memory is data memory in the drive that retains the values of all data even when power is disconnected from the drive. An EE (Electrically Erasable) chip is used for the non-volatile memory to store the drive parameters, links, and user text.</p>																														
owner parameters	<p>The 1336 IMPACT drive lets one or more control devices or adapters own start, jog, direction, and other control functions. To avoid conflict, some owners are exclusive. For example, only one device can issue a forward direction speed command. Others have multiple control. For example, all devices can jog the drive. Devices can, for example, jog the drive in the forward direction only if the jog mask parameter allows for it.</p>																														
parameter	<p>A parameter is a memory location used to store drive data. Each parameter is assigned a number and a name.</p>																														
per-unit numbering	<p>Per-unit numbering is a numbering system that defines a specific numeric value as representing 100% of a particular quantity being measured. The number 4096 is used in many places in the drive to represent one per unit.</p>																														
precharge	<p>Precharge limits the current into the drive when the incoming power is first applied.</p>																														
radians per second	<p>Radians per second are the units used to measure bandwidth. <math>\omega = 2\pi f</math>, where f is Hz or cycles per second.</p>																														
ridethrough	<p>Ridethrough automatically turns off the drive and starts a precharge when a power interrupt occurs. If the power returns within two seconds, the drive automatically starts.</p>																														
SCANport device	<p>A SCANport device is a generic term that is used to refer to any device that you can connect to the SCANport communications network.</p>																														
source parameter (read-only parameters)	<p>Source parameters provide realtime information that is available for other devices to use. These devices can include PLC controllers, operator interface devices, and programming terminals. throughout this manual, the following symbol indicates a source parameter: </p>																														

## Common Techniques Used in this Manual

The following conventions are used throughout this manual:

- Bulleted lists provide information, not procedural steps.
- Numbered lists provide sequential steps or hierarchical information.
- *Italic* type is used for parameter and chapter names.



*This type of paragraph contains tips or notes that have been added to call attention to useful information.*

<i>file:</i> Control
<i>group:</i> Speed Reference

This information is provided as a navigational tool. Use this information to locate parameters in the file/group structure. For example, to access a parameter in this section, you would first locate the *Control* file and then the *Speed Reference* group.

## Allen-Bradley Support

Allen-Bradley offers support services worldwide, with over 75 Sales/Support Offices, 512 authorized Distributors and 260 authorized Systems Integrators located throughout the United States alone, plus Allen-Bradley representatives in every major country in the world.

### Local Product Support

Contact your local Allen-Bradley representative for:

- sales and order support
- product technical training
- warranty support
- support service agreements

### Technical Product Assistance

If you need to contact Allen-Bradley for technical assistance, please review the information in the *Troubleshooting* chapter first. If you are still having problems, then call your local Allen-Bradley representative.

**Notes:**

## Overview

### Chapter Objectives

Chapter 1 provides an overview of your 1336 IMPACT drive.

This topic:	Starts on page:
An overview of the provided features	1-1
A description of the frame designators	1-4
A hardware overview	1-5

### What Features Does the 1336 IMPACT Drive Provide?

The 1336 IMPACT AC drive is a microprocessor-controlled digital AC drive with the following features:

- standard: 0.37 to 485 kW (0.5 to 650 hp) at 0 – 250 Hz constant torque  
configured: 522 to 597 kW (700 to 800 hp) at 0 – 250 Hz constant torque
- high-performance digital speed loop
- microprocessor-controlled, field-oriented current loop
- simplified programming through the use of a parameter table that features data entries in engineering units with English descriptions
- user-friendly interface with easy commissioning and set up
- non-volatile parameter storage
- extensive diagnostics, including both logic board and power structure tests
- 32 entry fault queue and 32 entry warning queue with markers for clear fault and power up and with time stamps
- enclosed construction
- multiple communication interfaces for SCANport™ access
- complete encoder interface through the L Option board (quadrature A, A NOT, B, B NOT with encoder supply + 12V)
- two 12-bit resolution analog inputs for ±10V
- two 12-bit resolution analog outputs for ±10V
- one 12-bit resolution 4 – 20mA input
- one 12-bit resolution 4 – 20mA output
- 5 or 12V DC pulse input
- bumpless speed/torque control
- programmable output contacts (relay)
- function blocks
- flux braking, DC braking, and bus regulation
- DC hold
- 200/400% motor curve

- S-Curve
- autostart (auto restart, power up start)
- start and stop dwells
- analog input filters
- process trim
- fast flux up
- 2/3 wire control
- feedback filters (light, heavy, lead/lag, and notch)
- Flying Start

### **Options**

The 1336 IMPACT drive provides the following options:

- DriveTools™, which is PC Windows™ based programming software compatible with the 1336 IMPACT drive and also other Allen-Bradley 1336 and 1395 products
- dynamic braking
- AC motor contactor
- L Option board with or without an encoder interface
- Human Interface Module (HIM)
- Graphics Programming Terminal (GPT)
- gateway modules (Bulletin 1203 communications modules)

### **Protective Features**

The 1336 IMPACT drive uses the following protective measures:

- programmable motor overload protection ( $I^2T$ ) investigated by UL to comply with NEC Article 430
- inverter overload protection (IT)
- overspeed detection, even when operating as a torque follower
- programmable stall detection
- peak output current monitoring to protect against excessive current at the output due to a phase-to-ground or phase-to-phase short
- ground fault monitoring
- DC bus voltage monitoring to protect against undervoltage or overvoltage conditions
- power structure heatsink temperature monitoring
- motor overspeed
- internal voltage reflection reduction mechanism

## How Do I Read the Catalog Number?

Knowing your catalog number for the 1336 IMPACT drive, can help you sort out what options you have, as well as helping you communicate this information to the Allen-Bradley support personnel. The catalog numbers all have the following form:

1336E First Position Bulletin Number	AQ Second Position Voltage	F05 Third Position Nominal HP Rating	AA Fourth Position Enclosure Type	EN Fifth Position Language	mods Sixth Position Options				
Letter	Voltages	Code	kW (HP)	Code	Type	Code	Language		
AQ	200–240VAC or 310VDC	F05	0.37 (0.5)	AA	NEMA 1 (IP20)	EN	English/English		
BR	380–480VAC or 513±620VDC	F07	0.56 (0.75)	AE	NEMA 1 (IP20)/ EMC 0.37–45 kW  (0.5–60 HP) only <sup>2</sup>	FR	English/French		
CW	500–600VAC or 775VDC	F10	0.75 (1)			ES	English/Spanish		
		F15	1.2 (1.5)			DE	English/German		
		F20	1.5 (2)	AF	NEMA 4 (IP65) <sup>2</sup>	IT	English/Italian		
		F30	2.2 (3)	AJ	NEMA 12 (IP54) <sup>2</sup>	PT	English/ Portuguese		
		F50	3.7 (5)	AN	Open (IP00)				
		F75	5.5 (7.5)						
		F100	7.5 (10)						
or									
A	200–240VAC	007	5.5 (7.5)						
B	380–480VAC	010	7.5 (10)						
BP	380–480VAC (F Frame)	015	11 (15)						
BX	Special Rating	020	15 (20)						
C	500–600VAC	025	18.5 (25)						
Q	310VDC	030	22 (30)						
R	513–620VDC	040	30 (40)						
RX	Special Rating	050	37 (50)						
W	775VDC	060	45 (60)						
		075	56 (75)						
		100	75 (100)						
		125	93 (125)						
		150	112 (150)						
		200	149 (200)						
		250	187 (250) <sub>1</sub>						
		300	224 (300) <sub>1</sub>						
		350	261 (350) <sub>1</sub>						
		400	298 (400) <sub>1</sub>						
		450	336 (450) <sub>1</sub>						
		500	373 (500) <sub>1</sub>						
		600	448 (600) <sub>1</sub>						
		650	485 (650) <sub>1</sub>						
		700C	522 (700) <sub>1</sub>						
		800C	597 (800)						

Code	Description
<b>Human Interface Module, IP 20 (NEMA Type 1)</b>	
HAB	Blank — No functionality
HAP	Programmer Only
HA1	Programmer/Controller w/Analog Pot
HA2	Programmer/Controller w/Digital Pot
<b>Human Interface Module, IP 65/54 (NEMA Type4/12)</b>	
HJP	Programmer Only
HJ2	Programmer/Controller w/Digital Pot
<b>Communication Options</b>	
GM1	Single Point Remote I/O
GM2	RS–232/422/485, DF1, & DH485
GM5	DeviceNet™
<b>Control Interface Options</b>	
L4	TTL Contact
L7E	TTL Contact & Encoder Feedback
L5	24VAC/DC
L8E	24VAC/DC & Encoder Feedback
L6	115VAC
L9E	115VAC & Encoder Feedback

1 G frame drives in enclosed construction and all H frame drives are supplied only through the Configured Drives Program.

2 D – G frame drives in IP 65 (NEMA Type 4) and IP 54 (NEMA Type 12) configurations are supplied through the Configured Drives Program.

Note: BPR indicates F frame roll-in units

## What is a Frame Designator?

Allen-Bradley uses frame designators to identify the various sizes of drives. Throughout this manual, the frame sizes are frequently referred to instead of the kW or horsepower rating.

The following frame sizes are currently available for the 1336 IMPACT drive:

If your drive falls into this three-phase drive rating <sup>1</sup> :			Then your frame reference is:
200 – 240V	380 – 480V	500 – 600V	
0.37 – 0.75 kW 0.5 – 1 hp	0.37 – 1.2 kW 0.5 – 1.5 hp	—	A1
1.2 – 1.5 kW 1.5 – 2 hp	1.5 – 2.2 kW 2 – 3 hp	—	A2
2.2 – 3.7 kW 3 – 5 hp	3.7 kW 5 hp	—	A3
—	5.5 – 7.5 kW 7.5 – 10 hp	0.75 – 3.7 kW 1 – 10 hp	A4
5.5 – 11 kW 7.5 – 15 hp	5.5 – 22 kW 15 – 30 hp	5.5 – 15 kW 15 – 20 hp	B
15 – 22 kW 20 – 30 hp	30 – 45 kW 40 – 60 hp	18.5 – 45 kW 25 – 60 hp	C
30 – 45 kW 40 – 60 hp	45 – 112 kW 60 – 150 hp	56 – 93 kW 75 – 125 hp	D
56 – 75 kW 75 – 125 hp	112 – 187 kW 150 – 250 hp	112 – 224 kW 150 – 300 hp	E
—	224 – 336 kW 300 – 450 hp	—	F
—	224 – 448 kW 300 – 600 hp	224 – 448 kW 300 – 600 hp	G
—	522 – 597 kW 700 – 800 hp	522 – 597 kW 700 – 800 hp	H

<sup>1</sup> kW and hp are constant torque.

Once you have determined your frame reference, write it here: \_\_\_\_\_

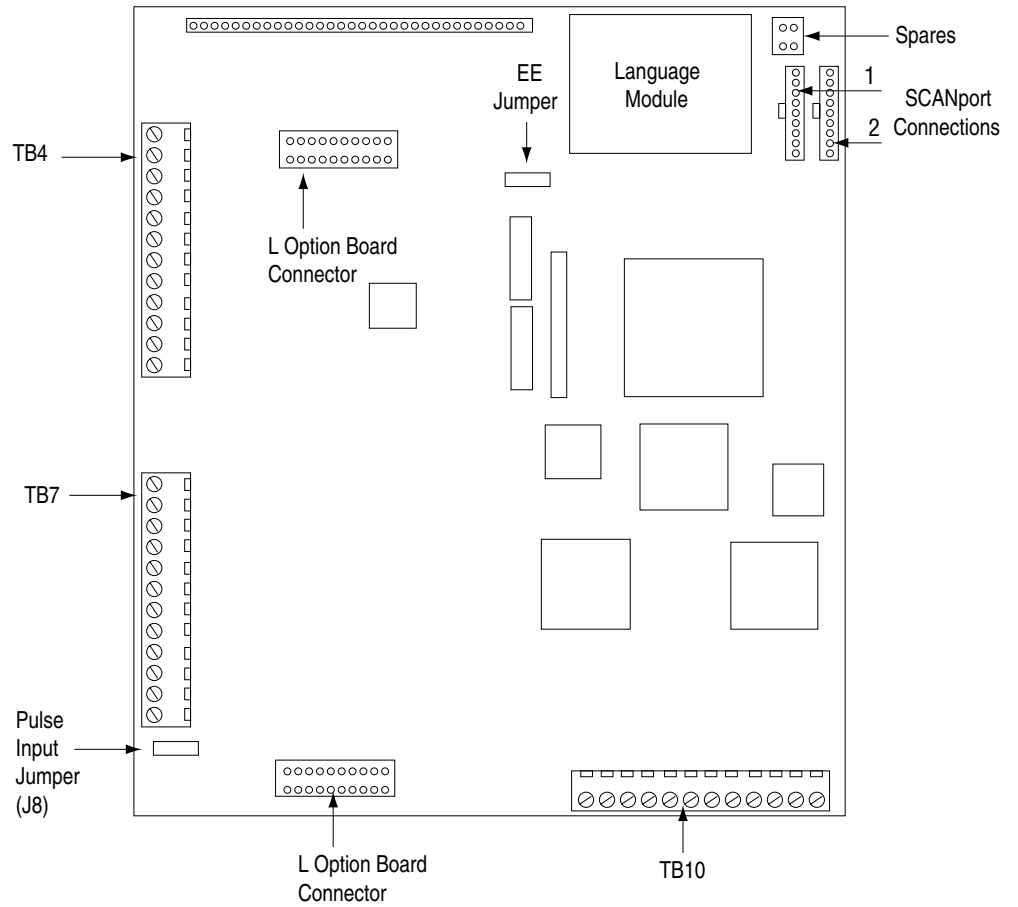
You can disregard information that is specific to other frame references.



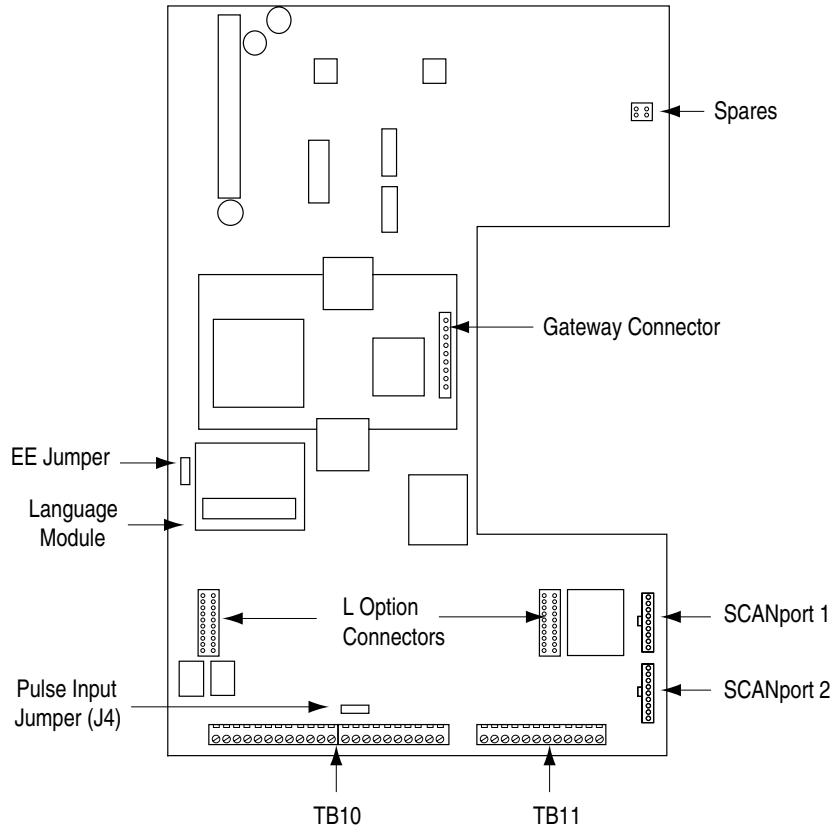
# Hardware Overview

Figures 1.1 and 1.2 show where the terminal blocks and L Option connectors are located.

**Figure 1.1**  
**Control Board for Frames A1, A2, A3, and A4**



**Figure 1.2**  
**Control Board for All Other Frames**



**Where Do I Go From Here?**

The installation and mounting instructions for your 1336 IMPACT drive are provided in Chapter 2, *Mounting and Wiring Your 1336 IMPACT Drive*. Some information is frame specific. For frame-specific information, refer to the appropriate chapter:

<b>If your drive frame reference is:</b>	<b>Then go to:</b>
A1, A2, A3, or A4	Chapter 3
B, C, D, E, F, G, or H	Chapter 4

## Mounting and Wiring Your 1336 IMPACT Drive

### Chapter Objectives

Chapter 2 provides information so that you can install your 1336 IMPACT drive.

This topic:	Starts on page:
Before mounting your drive	2-2
Input Fuses and Circuit Breakers	2-5
Mounting your drive	2-10
Grounding your drive	2-14
Wiring the power	2-17
Hard wiring your I/O	2-21
Connecting your gateway	2-24
Installing an interface board	2-25
Connecting the power to the drive	2-25
Disconnecting the drive output	2-27
Starting and stopping the motor	2-27
Electrical interference — EMI/RFI	2-28

**Important:** Some of the mounting and wiring information is specific to the individual frame sizes. This information is identified in this chapter, but is located in the following chapters:

Information for this frame size:	Is provided in:
A1, A2, A3, or A4	Chapter 3
B, C, D, E, F, G, or H	Chapter 4

If you do not know what your frame size is, please refer to Chapter 1, *Overview*.



**ATTENTION:** The following information is merely a guide for proper installation. The National Electric Code (NEC) and any other governing national, regional, or local code will overrule this information. Allen-Bradley cannot assume responsibility for the compliance or noncompliance to any code, national, local, or otherwise, for the proper installation of this drive or associated equipment. A hazard of personal injury and/or equipment damage exists if codes are ignored during installation.

## Before Mounting Your Drive

Before mounting your drive, consider the following:

- what tools and equipment you need to mount your drive
- the distance between the motor and the drive
- the distance between the drive and other surfaces

**Important:** Before you mount your drive, you need to thoroughly read and understand the information presented in this chapter. You should take every precaution to complete the wiring as instructed.

### Required Tools and Equipment

At a minimum, you will need the following tools and equipment to mount your drive:

- a small regular screw driver
- a medium phillips screw driver
- a box end wrench or socket set
- wire strippers

### Distance Between the Motor and the Drive

If the distance between the motor and the drive requires long motor cables, you may need to add an output reactor or cable terminators to limit voltage reflections at the motor. The following tables show the maximum length cable allowed for various installation techniques.

Values shown in Table 2.A are for 480V nominal input voltage and drive carrier frequency of 2 kHz. Consult factory regarding operation at carrier frequencies above 2 kHz. Multiply values by 0.85 for high line conditions. For input voltages of 380, 400 or 415V AC, multiply the table values by 1.25, 1.20 or 1.15, respectively.

Values shown in Table 2.B are for nominal input voltage and drive carrier frequency of 2 kHz. Consult factory regarding operation at carrier frequencies above 2 kHz. Multiply values by 0.85 for high line conditions.

If these tables indicate that your motor cables are not over the maximum cable length for your motor, you probably do not need a terminator or output reactor.

**Table 2.A**  
**Maximum Motor Cable Length Restrictions — 380V – 480V Drives<sup>7</sup>**  
 All Cable Lengths Given in meters (feet).

Drive Frame	Drive kW (hp)	Motor kW (hp)	No External Devices				w/1204-TFB2 Term.			w/1204-TFA1 Terminator					Reactor at Drive <sup>1</sup>								
			Motor				Motor			Motor					Motor								
			A <sup>2</sup>	B <sup>3</sup>	1329	1329R <sup>4</sup> , HR, L	A or B <sup>2, 3</sup>		1329	A <sup>2</sup>		B <sup>3</sup>		1329	A <sup>2</sup>	B or 1329							
			Any Cable	Any Cable	Any Cable	Any Cable <sup>5</sup>	Cable Type		Any Cable	Cable Type		Cable Type		Any Cable	Any Cable	Any Cable							
				Shld. <sup>6</sup>		Unshld.	Shld. <sup>f</sup>		Unshld.														
A1	0.37 (0.5)	0.37 (0.5)	12.2 (40)	33.5 (110)	114.3 (375)	91.4 (300)	<b>Use the 1204-TFA1 Terminator</b>						30.5 (100)	61.0 (200)	30.5 (100)	61.0 (200)	182.9 (600)	22.9 (75)	182.9 (600)				
	0.75 (1)	0.75 (1)	12.2 (40)	33.5 (110)	114.3 (375)	91.4 (300)							30.5 (100)	30.5 (100)	30.5 (100)	30.5 (100)	182.9 (600)	22.9 (75)	182.9 (600)				
		0.37 (0.5)	12.2 (40)	33.5 (110)	114.3 (375)	91.4 (300)							30.5 (100)	61.0 (200)	30.5 (100)	61.0 (200)	182.9 (600)	22.9 (75)	182.9 (600)				
A2	1.2 (1.5)	1.2 (1.5)	12.2 (40)	33.5 (110)	114.3 (375)	91.4 (300)							30.5 (100)	30.5 (100)	61.0 (200)	61.0 (200)	182.9 (600)	22.9 (75)	182.9 (600)				
		0.75 (1)	12.2 (40)	33.5 (110)	114.3 (375)	91.4 (300)							30.5 (100)	30.5 (100)	61.0 (200)	61.0 (200)	182.9 (600)	22.9 (75)	182.9 (600)				
		0.37 (0.5)	12.2 (40)	33.5 (110)	114.3 (375)	121.9 (400)							30.5 (100)	30.5 (100)	61.0 (200)	61.0 (200)	182.9 (600)	22.9 (75)	182.9 (600)				
	1.5 (2)	1.5 (2)	7.6 (25)	12.2 (40)	114.3 (375)	91.4 (300)	91.4 (300)	91.4 (300)	91.4 (300)	30.5 (100)	30.5 (100)	91.4 (300)	61.0 (200)	182.9 (600)	22.9 (75)	182.9 (600)							
		1.2 (1.5)	7.6 (25)	12.2 (40)	114.3 (375)	182.9 (600)	91.4 (300)	182.9 (600)	182.9 (600)	30.5 (100)	30.5 (100)	91.4 (300)	61.0 (200)	182.9 (600)	22.9 (75)	182.9 (600)							
		0.75 (1)	7.6 (25)	12.2 (40)	114.3 (375)	182.9 (600)	182.9 (600)	182.9 (600)	182.9 (600)	30.5 (100)	30.5 (100)	91.4 (300)	61.0 (200)	182.9 (600)	22.9 (75)	182.9 (600)							
		0.37 (0.5)	7.6 (25)	12.2 (40)	114.3 (375)	182.9 (600)	182.9 (600)	182.9 (600)	182.9 (600)	30.5 (100)	30.5 (100)	91.4 (300)	61.0 (200)	182.9 (600)	22.9 (75)	182.9 (600)							
	2.2 (3)	2.2 (3)	7.6 (25)	12.2 (40)	114.3 (375)	91.4 (300)	182.9 (600)	182.9 (600)	182.9 (600)	<b>Use the 1204-TFB2 Terminator</b>						22.9 (75)	182.9 (600)						
		1.5 (2)	7.6 (25)	12.2 (40)	114.3 (375)	182.9 (600)	182.9 (600)	182.9 (600)	22.9 (75)							182.9 (600)							
0.75 (1)		7.6 (25)	12.2 (40)	114.3 (375)	182.9 (600)	182.9 (600)	182.9 (600)	22.9 (75)	182.9 (600)														
0.37 (0.5)		7.6 (25)	12.2 (40)	114.3 (375)	182.9 (600)	182.9 (600)	182.9 (600)	22.9 (75)	182.9 (600)														
A3	3.7 (5)	3.7 (5)	7.6 (25)	12.2 (40)	114.3 (375)	For applications/ installations using new motors, no restrictions in lead length due to voltage reflection are necessary. You should observe standard practices for voltage drop, cable capacitance, and other issues.	182.9 (600)	182.9 (600)	182.9 (600)							<b>Use the 1204-TFB2 Terminator</b>						22.9 (75)	182.9 (600)
		2.2 (3)	7.6 (25)	12.2 (40)	114.3 (375)		182.9 (600)	182.9 (600)	182.9 (600)													22.9 (75)	182.9 (600)
		1.5 (2)	7.6 (25)	12.2 (40)	114.3 (375)		182.9 (600)	182.9 (600)	182.9 (600)													22.9 (75)	182.9 (600)
		0.75 (1)	7.6 (25)	12.2 (40)	114.3 (375)		182.9 (600)	182.9 (600)	182.9 (600)													22.9 (75)	182.9 (600)
		0.37 (0.5)	7.6 (25)	12.2 (40)	114.3 (375)		182.9 (600)	182.9 (600)	182.9 (600)	22.9 (75)	182.9 (600)												
A4	5.5 – 7.5 (7.5 – 10)	5.5 – 7.5 (7.5 – 10)	7.6 (25)	12.2 (40)	114.3 (375)	182.9 (600)	182.9 (600)	182.9 (600)	24.4 (80)	182.9 (600)													
B	5.5 – 22 (7.5 – 30)	5.5 – 22 (7.5 – 30)	7.6 (25)	12.2 (40)	114.3 (375)	182.9 (600)	182.9 (600)	182.9 (600)	24.4 (80)	182.9 (600)													
C	30 – 45 (X40 – X60)	30 – 45 (40 – 60)	7.6 (25)	12.2 (40)	114.3 (375)	182.9 (600)	182.9 (600)	182.9 (600)	76.2 (250)	182.9 (600)													
D	45 – 112 (60 – X150)	45 – 112 (60 – 150)	12.2 (40)	30.5 (100)	114.3 (375)	182.9 (600)	182.9 (600)	182.9 (600)	61.0 (200)	182.9 (600)													
E	112 – 187 (150 – 250)	112 – 224 (150 – 300)	12.2 (40)	53.3 (175)	114.3 (375)	For retrofit situations, check with the motor manufacturer for insulation rating.	182.9 (600)	182.9 (600)	182.9 (600)	182.9 (600)	182.9 (600)												
F	224 – 336 (300 – 450)	224 – 336 (300 – 450)	18.3 (60)	53.3 (175)	114.3 (375)		182.9 (600)	182.9 (600)	182.9 (600)	182.9 (600)	182.9 (600)												
G	224 – 448 (300 – 600)	224 – 448 (300 – 600)	18.3 (60)	53.3 (175)	114.3 (375)		182.9 (600)	182.9 (600)	182.9 (600)	182.9 (600)	182.9 (600)												
H	522 – 597 (700 – 800)	522 – 597 (700 – 800)	18.3 (60)	53.3 (175)	114.3 (375)		182.9 (600)	182.9 (600)	182.9 (600)	182.9 (600)	182.9 (600)												
			18.3 (60)	53.3 (175)	114.3 (375)		182.9 (600)	182.9 (600)	182.9 (600)	182.9 (600)	182.9 (600)												

1 A 3% reactor reduces motor and cable stress but may cause a degradation of motor waveform quality. Reactors must have a turn-turn insulation rating of 2100 volts or higher.

2 Type A Motor Characteristics: No phase paper or misplaced phase paper, lower quality insulation systems, corona inception voltages between 850 and 1000 volts

3 Type B Motor Characteristics: Properly placed phase paper, medium quality insulation systems, corona inception voltages between 1000 and 1200 volts

4 1329R Motors: These AC variable speed motors are power matched for use with Allen-Bradley drives. Each motor is energy efficient and designed to meet or exceed the requirements of the Federal Energy Act of 1992. All 1329R motors are optimized for variable speed operation and include premium inverter grade insulation systems which meet or exceed NEMA MG1. Part31.40.4.2.

5 These distance restrictions are due to charging of cable capacitance and may vary from application to application.

6 Includes wire in conduit.

7 Values shown are for 480V nominal input voltage and drive carrier frequency of 2 kHz. Consult factory regarding operation at carrier frequencies above 2 kHz. Multiply values by 0.85 for high line conditions. For input voltages of 380, 400 or 415V AC, multiply the table values by 1.25, 1.20 or 1.15, respectively.

**Table 2.B**  
**Maximum Motor Cable Length Restrictions — 500V – 600V Drives<sup>3</sup>**  
 All Cable Lengths Given in meters (feet)

Drive Frame	Drive kW (hp)	Motor kW (hp)	No External Devices			w/1204-TFB2 Terminator			w/1204-TFA1 Terminator			Reactor at Drive <sup>1</sup>		
			Motor w/Insulation V <sub>P-P</sub>			Motor w/Insulation V <sub>P-P</sub>			Motor w/Insulation V <sub>P-P</sub>			Motor w/Insulation V <sub>P-P</sub>		
			1000V	1200V	1600V <sup>2</sup>	1000V	1200V	1600V <sup>2</sup>	1000V	1200V	1600V <sup>2</sup>	1000V	1200V	1600V <sup>2</sup>
			Any Cable	Any Cable	Any Cable	Any Cable	Any Cable	Any Cable	Any Cable	Any Cable	Any Cable	Any Cable	Any Cable	Any Cable
A4	0.75 (1)	0.75 (1)	NR	NR	15.2 (50)	NR	182.9 (600)	335.3 (1100)	NR	61.0 (200)	182.9 (600)	Not Recommended		
		0.37 (0.5)	NR	NR	15.2 (50)	NR	182.9 (600)	335.3 (1100)	NR	61.0 (200)	182.9 (600)			
	1.5 (2)	1.5 (2)	NR	NR	15.2 (50)	NR	182.9 (600)	335.3 (1100)	NR	61.0 (200)	182.9 (600)			
		1.2 (1.5)	NR	NR	15.2 (50)	NR	182.9 (600)	335.3 (1100)	NR	61.0 (200)	182.9 (600)			
		0.75 (1)	NR	NR	15.2 (50)	NR	182.9 (600)	335.3 (1100)	NR	61.0 (200)	182.9 (600)			
		0.37 (0.5)	NR	NR	15.2 (50)	NR	182.9 (600)	335.3 (1100)	NR	61.0 (200)	182.9 (600)			
	2.2 (3)	2.2 (3)	NR	NR	15.2 (50)	NR	182.9 (600)	335.3 (1100)	NR	61.0 (200)	182.9 (600)			
		1.5 (2)	NR	NR	15.2 (50)	NR	182.9 (600)	335.3 (1100)	NR	61.0 (200)	182.9 (600)			
		0.75 (1)	NR	NR	15.2 (50)	NR	182.9 (600)	335.3 (1100)	NR	61.0 (200)	182.9 (600)			
		0.37 (0.5)	NR	NR	15.2 (50)	NR	182.9 (600)	335.3 (1100)	NR	61.0 (200)	182.9 (600)			
	3.7 (5)	3.7 (5)	NR	NR	15.2 (50)	NR	182.9 (600)	335.3 (1100)	NR	61.0 (200)	182.9 (600)			
		2.2 (3)	NR	NR	15.2 (50)	NR	182.9 (600)	335.3 (1100)	NR	61.0 (200)	182.9 (600)			
		1.5 (2)	NR	NR	15.2 (50)	NR	182.9 (600)	335.3 (1100)	NR	61.0 (200)	182.9 (600)			
		0.75 (1)	NR	NR	15.2 (50)	NR	182.9 (600)	335.3 (1100)	NR	61.0 (200)	182.9 (600)			
		0.37 (0.5)	NR	NR	15.2 (50)	NR	182.9 (600)	335.3 (1100)	NR	61.0 (200)	182.9 (600)			
	B	5.5 – 15 (7.5 – 20)	5.5 – 15 (7.5 – 20)	NR	9.1 (30)	15.2 (50)	91.4 (300)	182.9 (600)	182.9 (600)	NR	61.0 (200)			
C	18.5 – 45 (25 – 60)	18.5 – 45 (25 – 60)	NR	9.1 (30)	12.2 (40)	91.4 (300)	182.9 (600)	182.9 (600)	NR	61.0 (200)	182.9 (600)	30.5 (100)	91.4 (300)	182.9 (600)
D	56 – 93 (75 – 125)	56 – 93 (75 – 125)	NR	9.1 (30)	33.5 (110)	91.4 (300)	182.9 (600)	182.9 (600)	NR	61.0 (200)	182.9 (600)	61.0 (200)	91.4 (300)	182.9 (600)
E	112 – 224 (150 – X300)	112 – 224 (150 – X300)	NR	9.1 (30)	21.3 (70)	91.4 (300)	182.9 (600)	182.9 (600)	NR	61.0 (200)	182.9 (600)	182.9 (600)	182.9 (600)	182.9 (600)
F	224 – 336 (300 – 450)	224 – 336 (300 – 450)	NR	9.1 (30)	41.1 (135)	91.4 (300)	182.9 (600)	182.9 (600)	NR	61.0 (200)	182.9 (600)	182.9 (600)	182.9 (600)	182.9 (600)
G	224 – 448 (300 – 600)	224 – 448 (300 – 600)	NR	9.1 (30)	41.1 (135)	91.4 (300)	182.9 (600)	182.9 (600)	NR	61.0 (200)	182.9 (600)	182.9 (600)	182.9 (600)	182.9 (600)
H	522 – 597 (700 – 800)	522 – 597 (700 – 800)	NR	9.1 (30)	41.1 (135)	91.4 (300)	182.9 (600)	182.9 (600)	NR	61.0 (200)	182.9 (600)	182.9 (600)	182.9 (600)	182.9 (600)

1 A 3% reactor reduces motor and cable stress but may cause a degradation of motor waveform quality. Reactors must have a turn-turn insulation rating of 2100 volts or higher.

2 1329R only

3 Values shown are for nominal input voltage and drive carrier frequency of 2 kHz. Consult factory regarding operation at carrier frequencies above 2 kHz. Multiply values by 0.85 for high line conditions.

NR = Not Recommended

## Input Fuses and Circuit Breakers

The 1336 IMPACT can be installed with either input fuses or an input circuit breaker. Local/national electrical codes may determine additional requirements for these installations.

### Installations per U.S. NEC/UL/CSA

**Fuses** - In general, the specified fuses are suitable for branch short circuit protection and provide excellent short circuit protection for the drive. The fuses offer a high interrupting capacity and are fast acting. Refer to the North American selections in Chapter 3 for A1-A4 frames and Chapter 4 for B-H frames.

**Circuit Breakers** - The Westinghouse HMCP breakers specified in the following table provide branch short circuit protection. Because circuit breakers are typically slower than fuses and those listed are magnetic trip only, they may not be as effective in offering short circuit protection to the drive in the event of an internal drive short circuit. They may not be as effective in limiting damage to the drive.

### IEC Installations

**Fuses** - For those installations that are not required to meet the U.S. NEC/UL/CSA, the specified fuses are suitable for branch short circuit protection and provide excellent short circuit protection for the drive. The fuses offer a high interrupting capacity and are fast acting. Refer to the European selections in Chapter 3 for A1-A4 frames and Chapter 4 for B-H frames.

**Circuit Breakers** - For those installations that are not required to meet the U.S. NEC/UL/CSA requirements, additional devices are available as input circuit breakers. The Bulletin 140 and KTA3 devices meet the circuit breaker requirements. They can be used in “non-U.S.” installations where local/national codes allow, if they are installed per their installation instructions.



**ATTENTION:** The 1336 PLUS II does not provide input power short circuit protection. Specifications for the recommended fuse or circuit breaker to provide drive input power protection against short circuits are provided.

### Recommended AC Line Circuit Breakers (User Supplied)

Drive Catalog Number	Maximum Rated Vt kW (HP)	IEC Installations per IEC947-2		UL/CSA Installations		
		Bulletin 140 Circuit Breaker		HMCP Circuit Breaker <sup>2</sup>		
		Catalog Number	Rated Service Short Circuit Capability 400/415V	Catalog Number	MCP Trip Setting	Max. Short Circuit Amps <sup>3</sup> 480V
1336E-AQF05	0.37 (0.5)	140-MN-0400	100,000	HMCP007C0	H	65,000
1336E-AGF07	0.56 (0.75)	140-MN-0400	100,000	HMCP015E0C	E	65,000
1336E-AQF10	0.75 (1)	140-MN-0630	100,000	HMCP015E0C	E	65,000
1336E-AQF15	1.2 (1.5)	140-MN-1000	16,000	HMCP015E0C	E	65,000
1336E-AQF20	2.2 (3)	140-MN-1000	16,000	HMCP030H1C	F	65,000
1336E-AQF30	3.7 (5)	140-MN-1000	16,000	HMCP030H1C	F	65,000

Drive Catalog Number	Maximum Rated Vt kW (HP)	IEC Installations per IEC947-2		UL/CSA Installations		
		Bulletin 140 Circuit Breaker		HMCP Circuit Breaker <sup>2</sup>		
		Catalog Number	Rated Service Short Circuit Capability 400/415V	Catalog Number	MCP Trip Setting	Max. Short Circuit Amps <sup>3</sup> 480V
1336E-AQF50	3.7 (5)	140-MN-2500	6,000	HMCP503H1C	H	65,000
1336E-A007	5.5 (7.5)	140-CMN-4000	65,000	HMCP5030H1C	H	65,000
1336E-A010	7.5 (10)	140-CMN-4000	65,000	HMCP5050K2C	F	65,000
1336E-A015	11 (15)	140-CMN-6300	50,000	HMCP5050K2C	H	65,000
1336E-A020	15 (20)	140-CMN-6300	50,000	HMCP100R3C	G	65,000
1336E-A025	18.5 (25)	140-CMN-9000	25,000	HMCP100R3C	H	65,000
1336E-A030	22 (30)	140-CMN-9000	25,000	HMCP100R3C	H	65,000
1336E-A040	30 (40)	KTA3-160S-125	65,000	HMCP150T4C	F	65,000
1336E-A050	37 (50)	KTA3-160S-160	65,000	HMCP150T4C	G	65,000
1336E-A060	45 (60)	KTA3-250S-200	65,000	HMCP250A5	E	65,000
1336E-A075	56 (75)	KTA3-250S-250	65,000	HMCP250A5	E	65,000
1336E-A100	75 (100)	KTA3-400S-320	65,000	HMCP400J5	I	65,000
1336E-A125	93 (125)	KTA3-400S-320	65,000	HMCP400J5	I	65,000
1336E-BRF05	0.37 (0.5)	140-MN-0250	100,000	HMCP5003A0	E	65,000
1336E-BRF07	0.56 (0.75)	140-MN-0250	100,000	HMCP5003A0	G	65,000
1336E-BRF10	0.75 (1)	140-MN-0400	100,000	HMCP5003A0	G	65,000
1336E-BRF15	1.2 (1.5)	140-MN-0400	100,000	HMCP5007C0	B	65,000
1336E-BRF20	1.5 (2)	140-MN-0630	100,000	HMCP5007C0	C	65,000
1336E-BRF30	2.2 (3)	140-MN-1000	16,000	HMCP5015E0C	B	65,000
1336E-BRF50	3.7 (5)	140-MN-1000	16,000	HMCP5015E0C	D	65,000
1336E-BRF75	5.5 (7.5)	140-MN-1600	6,000	HMCP5015E0C	H	65,000
1336E-BRF100	7.5 (10)	140-MN-2000	6,000	HMCP5030H1C	H	65,000
1336-B010	11 (15)	140-MN-2000	6,000	HMCP5030H1C	E	65,000
1336-B015	15 (20)	140-MN-2500	6,000	HMCP5030H1C	H	65,000
1336-B020	18.5 (25)	140-CMN-4000	65,000	HMCP5050K2C	H	65,000
1336-B025	22 (30)	140-CMN-4000	65,000	HMCP5050K2C	H	65,000
1336-B030	22 (30)	140-CMN-6300	50,000	HMCP5050K2C	H	65,000
1336-BX040	30 (40)	140-CMN-6300	50,000	HMCP5050K2C	H	65,000
1336-B040	37 (50)	140-CMN-6300	50,000	HMCP100R3C	G	65,000
1336-B050	45 (60)	140-CMN-9000	25,000	HMCP100R3C	G	65,000
1336E-BX060	45 (60)	140-CMN-9000	25,000	HMCP100R3C	G	65,000
1336E-B060	56 (75)	KTA3-160S-125	65,000	HMCP150T4C	F	65,000
1336E-B075	75 (100)	KTA3-160S-125	65,000	HMCP150T4C	H	65,000
1336E-B100	93 (125)	KTA3-160S-160	65,000	HMCP150U4C	E	65,000
1336E-B125	112 (150)	KTA3-250S-200	65,000	HMCP250K5	H	65,000
1336E-BX150	112 (150)	KTA3-250S-200	65,000	HMCP250K5	H	65,000
1336E-B150	149 (200)	KTA3-400S-320	65,000	HMCP250L5	I	65,000
1336E-B200	187 (250)	KTA3-400S-320	65,000	HMCP400N5	H	65,000
1336E-B250	224 (300)	KTA3-400S-400	65,000	HMCP400N5	I	65,000
1336E-BP250	224 (300)	KTA3-400S-400	65,000	HMCP400N5	I	65,000
1336E-B300	261 (350)	NA	-	NA	-	-
1336E-BP300	298 (400)	KTA-400S-400	65,000	HMCP400R5	I	65,000



Drive Catalog Number	Maximum Rated Vt kW (HP)	IEC Installations per IEC947-2		UL/CSA Installations		
		Bulletin 140 Circuit Breaker		HMCP Circuit Breaker <sup>2</sup>		
		Catalog Number	Rated Service Short Circuit Capability 400/415V	Catalog Number	MCP Trip Setting	Max. Short Circuit Amps <sup>3</sup> 480V
1336E-B350	298 (400)	NA	NA	NA	-	-
1336E-BP350	261 (350)	NA	NA	HMCP600L6W	E	65,000
1336E-B400	336 (450)	NA	NA	NA	-	-
1336E-BP400	298 (400)	NA	NA	HMCP600L6W	E	65,000
1336E-B450	373 (500)	NA	NA	NA	-	-
1336E-BP450	336 (450)	NA	NA	HMCP600L6W	E	65,000
1336E-B500	448 (600)	NA	NA	NA	-	-
1336E-C001	0.75 (1)	140-MN-0400	100,000	HMCP003A0	E	65,000
1336E-C003	2.2 (3)	140-MN-0630	100,000	HMCP007C0	E	65,000
1336E-C007	5.5 (7.5)	140-MN-1000	16,000	HMCP015E0C	E	65,000
1336E-C010	7.5 (10)	140-MN-1600	6,000	HMCP015E0C	E	65,000
1336E-C015	11 (15)	140-MN-2000	6,000	HMCP030H1C	F	65,000
1336E-C020	15 (20)	140-MN-2500	6,000	HMCP030H1C	H	65,000
1336E-C025	18.5 (25)	140-CMN-4000	65,000	HMCP050K2C	E	65,000
1336E-C030	22 (30)	140-CMN-4000	65,000	HMCP050K2C	G	65,000
1336E-C040	30 (40)	140-CMN-6300	50,000	HMCP050K2C	G	65,000
1336E-C050	37 (50)	140-CMN-6300	50,000	HMCP100R3C	E	65,000
1336E-C060	45 (60)	140-CMN-6300	50,000	HMCP100R3C	E	65,000
1336E-C075	56 (75)	140-CMN-9000	25,000	HMCP100R3C	G	65,000
1336E-C100	75 (100)	KTA3-160S-125	65,000	HMCP150T4C	E	65,000
1336E-C125	93 (125)	KTA3-160S-160	65,000	HMCP150T4C	E	65,000
1336E-C150	112 (150)	KTA3-400S-160	65,000	HMCP150T4C	G	65,000
1336E-C200	149 (200)	KTA-400S-320	65,000	HMCP250J5	I	65,000
1336E-C250	187 (250)	KTA3-400S-320	65,000	HMCP400W5	G	65,000
1336E-CX300	224 (300)	KTA3-400S-320	65,000	HMCP400W5	H	65,000
1336E-C300	224 (300)	KTA3-400S-320	65,000	HMCP400W5	H	65,000
1336E-C350	261 (350)	KTA3-400S-320	65,000	NA	NA	NA
1336E-C400	298 (400)	KTA3-400S-320	65,000	NA	NA	NA
1336E-C450	336 (450)	NA	NA	NA	NA	NA
1336E-C500	373 (500)	NA	NA	NA	NA	NA
1336E-C600	448 (600)	NA	NA	NA	NA	NA

NA = Not Available, use fuses

<sup>1</sup> Bulletin 140 - At 480 volts, circuit breaker must have a fuse backup. Refer to the AB Industrial Control Catalog. At 600 volts, additional restrictions apply. No limitations in source short circuit ratings.

<sup>2</sup>HMCP Circuit Breaker - HMCP Breaker is a magnetic trip device only. Always set the trip setting as low as possible in a particular application.

<sup>3</sup>Current limiting option can extend this value to 200,000A RMS

### Reducing Voltage Reflections

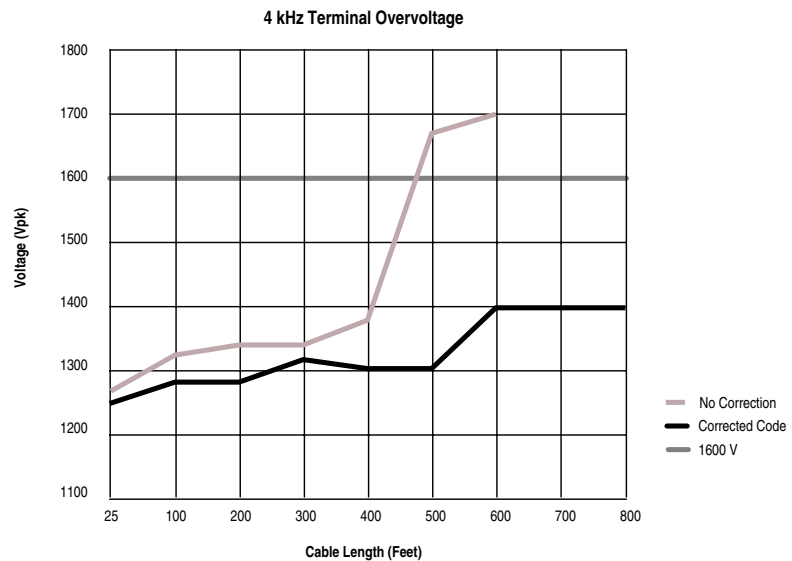
Voltage doubling at motor terminals, known as reflected wave phenomenon or transmission line effect, can occur when using drives with long motor cables.

The 1336 IMPACT drive is equipped with an internal voltage reflection reduction mechanism. This mechanism provides a minimum dwell time that is controlled so that voltage transients are allowed to decay, thus reducing motor overvoltage. This limits the voltage seen at the motor terminals to 2.2 per unit and greatly increases the run length of the motor cable before a terminator is required.

You should use inverter duty motors with phase-to-phase insulation ratings of 1600 volts or higher to minimize effects of reflected wave on motor insulation life.

Without the dwell time correction, the voltage reflection transients surpass the insulation rating of the motor with less than 500 feet of cable. With the introduction of a controlled dwell time, the voltage transients are safely maintained below the insulation rating of the motor. In Figure 2.1, the terminal voltage is plotted as a function of cable distance for a 1336 IMPACT drive at a 4 kHz carrier frequency.

**Figure 2.1**  
**Terminal Voltage at a 4 kHz Carrier Frequency**



### Optional Cable Terminator

Applications with non-inverter duty motors or any motor with exceptionally long leads may require an output inductor or cable terminator. An inductor or Bulletin 1204 terminator helps limit reflection to the motor, to levels that are less than the motor insulation value.

### Optional Output Reactor

You can use the reactors listed in the 1336 IMPACT drive price list for drive input and output. These reactors are specifically constructed to accommodate IGBT inverter applications with switching frequencies up to 20 kHz. They have a UL approved dielectric strength of 4000 volts, opposed to a normal rating of 2500 volts. The first two and last two turns of each coil are triple insulated to guard against insulation breakdown resulting from high dv/dt. When using motor line reactors, set the drive PWM frequency to its lowest value to minimize losses in the reactors.

**Important:** By using an output reactor, the effective motor voltage is lower because of the voltage drop across the reactors — this may also reduce motor torque.

### Common Mode Cores

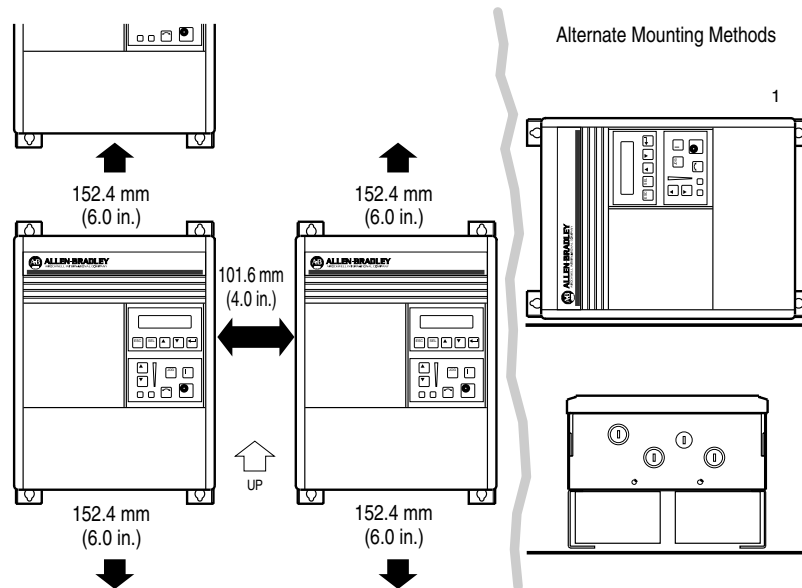
Common mode cores help reduce the common mode noise at the drive output and guard against interference with other electrical equipment (such as programmable controllers, sensors, and analog circuits). In addition, reducing the PWM carrier frequency reduces the effects and lowers the risk of common mode noise interference. The following table shows the common mode cores available for the 1336 IMPACT drive.

Catalog Number	Used with:	Description
1321-M001	Communications cables, analog signal cables, etc.	Open style — signal level
1321-M009	All 1336 IMPACT drives rated: 480V, 0.37 – 3.7 kW (0.5 – 5 hp)	Open style with terminal block, 9A
1321-M048	All 1336 IMPACT drives rated: 480V, 5.5 – 22 kW (7.5 – 30 hp) 600V, 5.5 – 30 kW (7.5 – 40 hp)	Open style, 48A
1321-M180	All 1336 IMPACT drives rated: 480V, 30 – 112 kW (40 – X150 hp) 600V, 37 – 93 kW (50 – 125 hp)	Open style, 180A
1321-M670	All 1336 IMPACT drives rated: 480V, 112 – 597 kW (150 – 800 hp) 600V, 149 – 597 kW (200 – 800 hp)	Open Style, 670A

## Allowing for Heat Dissipation

You need to mount the drive so that there is sufficient space at the top, sides, and front of the cabinet to let the heat dissipate as shown in Figure 2.2.

**Figure 2.2**  
Heat Dissipation Requirements



- 1 If you have a D frame drive, you should have at least 152.4 – 203.2 mm (6 – 8 in.) between the drive and the bottom surface.

**IMPORTANT:** A4 Frame drives should not be mounted on a combustible surface. However, if the drive must be mounted on a combustible surface, 6.35 mm (0.25 in.) spacers must be provided under the mounting feet of the drive.

F Frame drives require a minimum of 152.4 mm (6.0 in.) between the drive back and mounting wall, if drives are mounted with the sides touching another device or wall. A minimum of 76.2 mm (3.0 in.) is required on the sides if the back of the drive is mounted against a wall or other device.

► *The alternate mounting methods shown in Figure 2.2 cannot be used for Frames F, G, or H.*

## Mounting Your Drive

To mount your drive, you need to:



**ATTENTION:** You must be careful to prevent debris (such as metal shavings and conduit knockouts) from falling into the drive while performing any installation work on or around the drive. A hazard of personal injury and/or equipment damage exists if foreign material lodges inside the drive.

1. Get the dimensions for your drive from the frame-specific chapters.
2. Drill the holes at the appropriate spot (as determined from the drive dimensions).
3. Bolt the drive to the mounting surface.

## User-Supplied Enclosures

If you are supplying your own enclosure for the 1336 IMPACT drive, you can mount your drive within an enclosure or you may mount the drive to let the heatsink extend outside the enclosure.

F Frame drives with the suffixes -BPR and CPR (Standalone) and RPR and WPR (Common-bus) have the following enclosure requirements:

A) Dimensions of enclosure needed to accommodate the drive are nominally 90 by 35 by 20 in.

B) A 1200 cfm enclosure ventilating fan is required to be installed by the customer or installer.

C) For the -BPR and -CPR only, additional mounting instructions specifying the relative locations of the drive and choke so that factory supplied interconnecting cables can be utilized are supplied.

- ▶ *If you have a G frame, do not mount the drive with the heatsink extended outside of the enclosure.*
  
- ▶ *If you have an H frame and you are supplying your own piped-in cooling for the 1336 IMPACT drive enclosures or are calculating room cooling requirements, refer to the following table. NEMA Type 1 enclosures from the factory will have exhaust fans and will not require additional enclosure cooling, but may require room ambient cooling so as not to exceed 40°C.*
  
- ▶ *The H frame drive has been tested only as a complete unit including the enclosure. The enclosure is an integral part of the cooling package. The enclosure dimensions are provided in Chapter 4. The required fan volume is 2600 CFM, and air enters at the front bottom of the enclosure and exits out the top. Any change to this configuration is at the customers risk. Air must not be restricted at top or bottom of the enclosure to ensure good air flow over the capacitor and bus bars, as well as to assist the heat sink fans to maintain the 800HP rating.*

Use the information in the following table along with the enclosure manufacturer's guidelines for sizing.

Catalog Number	Base Derate Amps <sup>1</sup>	Derate Curve <sup>2,3</sup>	Heat Dissipation Drive Watts <sup>2,3</sup>	Heatsink Watts <sup>2</sup>	Total Watts <sup>2</sup>
<b>200 – 240V drives</b>					
AQF05	2.3	Figure D.1	13	15	28
AQF07	3.0	Figure D.1	15	21	36
AQF10	4.5	Figure D.1	17	32	49
AQF15	6.0	Figure D.1	21	42	63
AQF20	8.0	Figure D.1	25	56	81
AQF30	12.0	Figure D.1	33	72	105
AQF50	18.0	Figure D.1	42	116	158
A007	27.2	none	156	486	642
A010	33.7	Figure D.2	200	721	921
A015	48.2	Figure D.3	205	819	1024
A020	64.5	Figure D.4	210	933	1143
A025	78.2	Figure D.5	215	1110	1325
A030	80.0	None	220	1110	1330
A040	120.3	Figure D.6	361	1708	2069
A050	149.2	Figure D.7	426	1944	2370
A060	180.4	Figure D.8	522	2664	3186
A075	240.0	Figure D.9	606	2769	3375
A100	291.4	Figure D.10	755	3700	4455
A125	327.4	Same as B250	902	4100	5002
<b>380 – 480V drives</b>					
BRF05	1.2	Figure D.1	12	9	21
BRF07	1.7	Figure D.1	13	15	28
BRF10	2.3	Figure D.1	15	20	35
BRF15	3.0	Figure D.1	16	27	43
BRF20	4.0	Figure D.1	19	36	55
BRF30	6.0	Figure D.1	23	54	77
BRF50	10.4	Figure D.1	29	84	113
BRF75	13.9	Figure D.1	70	230	300
BRF100	24.0	Figure D.1	89	331	420
B015	27.2	Figure D.11	117	486	603
B020	33.7	Figure D.2	140	628	768
B025	41.8	Figure D.12	141	720	861
B030	48.2	Figure D.3	141	820	961
BX040	58.7	Figure D.13	175	933	1108
B040	64.5	Figure D.4	175	933	1108
B050	78.2	Figure D.5	193	1110	1303
BX060	78.2	Figure D.5	193	1110	1303
B060	96.9	<sup>4</sup>	361	1708	2069

1 Base derate amps are based on nominal voltage (240, 480, or 600V). If the input voltage exceeds the drive rating, the drive output must be derated. Refer to Figure D.41.

2 Drive ambient temperature rating is 40°C. If ambient exceeds 40°C, derate the drive. Refer to Figures D.1 – D.39.

3 Drive rating is based on altitudes of 1000m (3000ft) or less. If installed at a higher altitude, derate the drive. Refer to Figure D.40.

4 Not available at time of publication.

Catalog Number	Base Derate Amps <sup>1</sup>	Derate Curve <sup>2,3</sup>	Heat Dissipation Drive Watts <sup>2,3</sup>	Heatsink Watts <sup>2</sup>	Total Watts <sup>2</sup>
B075	120.3	Figure D.14	361	1708	2069
B100	149.2	Figure D.15	426	1944	2370
B125	180.4	Figure D.16	522	2664	3186
BX150	180.4	Figure D.16	606	2769	3375
B150	240.0	Figure D.9	606	2769	3375
B200	291.4	Figure D.10	755	3700	4455
B250	327.4	Figure D.17	902	4100	5002
B300 <sup>5</sup>	406.4	none	1005	4805	5810
BP300	406.4	Figure D.18	<sup>4</sup>	<sup>4</sup>	<sup>4</sup>
B350 <sup>5</sup>	459.2	none	1055	5455	6510
BP350	459.2	Figure D.19	<sup>4</sup>	<sup>4</sup>	<sup>4</sup>
B400 <sup>5</sup>	505.1	none	1295	6175	7470
BP400	481.0	Figure D.20	<sup>4</sup>	<sup>4</sup>	<sup>4</sup>
B450 <sup>5</sup>	570.2	none	1335	6875	8210
BP450	531.7	Figure D.21	<sup>4</sup>	<sup>4</sup>	<sup>4</sup>
B500 <sup>5</sup>	599.2	Figure D.22	1395	7800	9200
B600 <sup>5</sup>	673.4	Figure D.23	1485	8767	10252
B700C	850.0	Figure D.24	1700	9700 <sup>5</sup>	11400
B800C	983.0	Figure D.24	1900	12000 <sup>5</sup>	13900
<b>500 – 600V drives</b>					
CWF10	2.5	<sup>4</sup>	25	29	54
CWF20	4.2	<sup>4</sup>	29	57	86
CWF30	6.0	<sup>4</sup>	32	87	119
CWF50	7.9	<sup>4</sup>	35	117	152
CWF75	9.9	none	91	217	308
CWF100	12.0	none	103	251	354
C015	18.9	none	117	360	477
C020	23.6	none	140	467	607
C025	30.0	none	141	492	633
C030	34.6	none	141	526	667
C040	45.1	none	175	678	853
C050	57.2	none	193	899	1092
C060	61.6	<sup>4</sup>	193	981	1174
C075	85.8	Figure D.25	361	1553	1894
C100	109.1	Figure D.26	426	1978	2504
C125	138.6	Figure D.27	522	2162	2683
C150	159.7	Figure D.28	<sup>4</sup>	<sup>4</sup>	<sup>4</sup>
C200	252.6	Figure D.29	755	3065	3820
C250	283.6	Figure D.30	890	3625	4515
C300 <sup>5</sup>	298.0	none	926	5015	5941
CX300	300.0	none	926	3990	4930
C350 <sup>5</sup>	353.6	none	1000	5935	6935
CP350	350.0	Figure D.33	580	6125	6705
CPR 350	350.0	none	580	6125	6705
C400 <sup>5</sup>	406.4	Figure D.31	1430	7120	8550
CP400	400.0	Figure D.34	711	7000	7711
C450 <sup>5</sup>	459.2	Figure D.32	1465	8020	9485
C500 <sup>5</sup>	505.1	Figure D.37	1500	8925	10425
C600 <sup>5</sup>	599.2	Figure D.38	1610	10767	12377
C650 <sup>5</sup>	673.4	Figure D.39	1700	12000	14000
C700C	770.0	Figure D.39	1800	9400 <sup>6</sup>	11200
C800C	800.0	Figure D.39	2000	11300 <sup>6</sup>	13300

1 Base derate amps are based on nominal voltage (240, 480, or 600V). If the input voltage exceeds the drive rating, the drive output must be derated. Refer to Figure D.41.

2 Drive ambient temperature rating is 40 degrees C. If ambient exceeds 40 degrees C, derate the drive. Refer to Figures D.1 – D.39.

3 Drive rating is based on altitudes of 1000 m (3000 ft) or less. If installed at a higher altitude, derate the drive. Refer to Figure D.40

4 Not available at time of publication

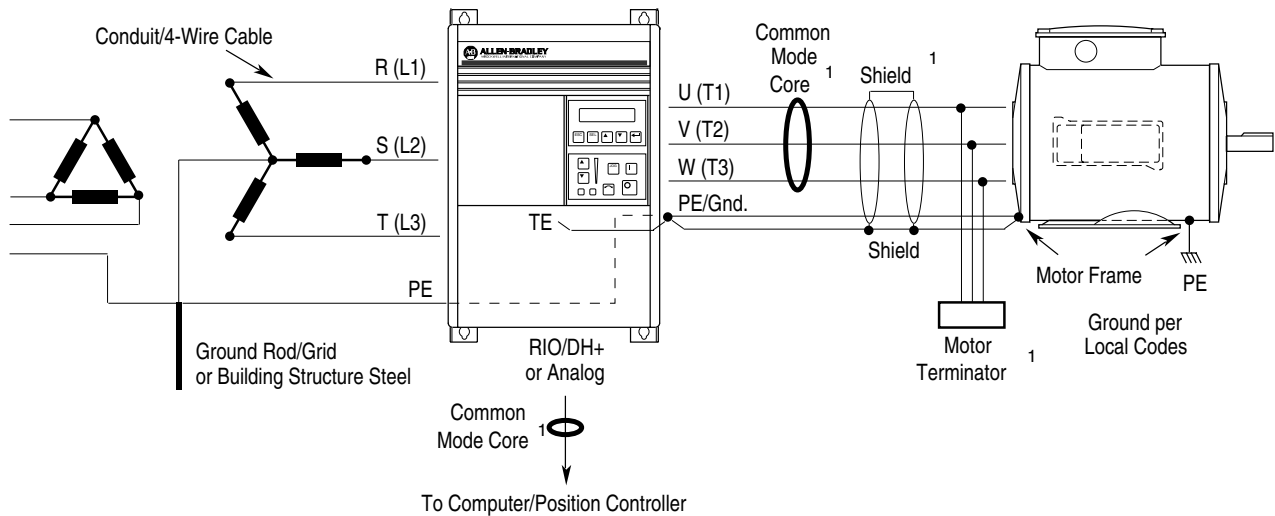
5 IMPORTANT: Two 725 CFM fans are required if an open type drive is mounted in a user supplied enclosure.

6 This is the inverter loss only, common bus configuration 1 kHz PWM.

## Grounding Your Drive

You need to properly ground your 1336 IMPACT drive. Figure 2.3 shows the grounding recommendations for the 1336 IMPACT drive.

**Figure 2.3**  
**Recommended 1336 IMPACT Drive Grounding**



To ground your 1336 IMPACT drive, you need to:

1. Connect the drive to the system ground at the power ground (PE) terminal provided on the power terminal block (TB1).
2. Define the paths through which the high frequency ground currents flow.
3. Connect the ground conductor of the motor cable (drive end) directly to the drive ground terminal, not to the enclosure bus bar.
4. Ground the encoder connections (if you are using an encoder).
5. Ground the control and signal wiring.
6. Connect the TE terminal block.
7. Connect the ground bus to adjacent building steel or a floor ground loop.
8. Solidly ground the RFI filter, if you need to use one.

These steps are explained in greater detail in the following sections.



## Connecting the Drive to the System Ground

Connect the drive to the system ground at the power ground (PE) terminal provided on the power terminal block (TB1). Ground impedance must conform to the requirements of national and local industrial safety regulations (such as NEC, VDE 0160, and BSI). You should inspect and test the ground impedance at appropriate and regular intervals.

▶ *Even if you have a floating secondary, the building must have a safety (earth) ground.*

In any cabinet, you should use a single, low-impedance ground point or ground bus bar. You should:

- Ground all circuits independently and directly to this ground point or bus bar.
- Directly connect the AC supply ground conductor to this ground point or bus bar.

## Defining the High Frequency Ground Current Paths

You need to define the paths through which the high frequency ground currents flow. Defining these paths helps to assure that noise-sensitive circuits do not share a path with high-frequency ground currents and to minimize the area enclosed by these paths. You must separate current carrying ground conductors. Control and signal ground conductors should not run near or parallel to a power ground conductor.

## Connecting the Ground Conductor of the Motor Cable

Connect the ground conductor of the motor cable (drive end) directly to the drive ground terminal, not to the enclosure bus bar. Grounding directly to the drive (and filter, if installed) provides a direct route for high-frequency current returning from the motor frame and ground conductor. At the motor end, you should also connect the ground conductor to the motor case ground.

If you use shielded or armored cables, connect the shield to the drive chassis and the motor frame.

### Making the Encoder Connections

If you want to use an encoder, you need to use an L Option board. If you do not have an L Option board, you cannot use an encoder.

To make the encoder connections, you must:

1. Route the connections in grounded steel conduit or shield cable in a wire tray. If cables are run in a wire tray, you must separate the signal and encoder wire from the power cables, preferably with a steel divider.
2. Ground the conduit at both ends.
3. Ground the cable shield only at the drive.

For additional information about using an encoder, refer to Chapter 5, *Using the L Option*.

### Grounding the Discrete Control and Signal Wiring

To ground the control and signal wiring, you need to:

1. Ground the 0V or ground terminal at the equipment (source) end, not the drive end. You must ground all control and signal wiring at a single point in the system, remote from the drive.
2. Ground the shield if you are using shielded control and signal wires.

### Connecting the TE Terminal Block

The TE terminal block is used for all control signal shields within the drive. Refer to the frame specific chapters for the TE terminal block location.

The TE terminal block accepts wire with the following specifications:

Wire information	Description
Minimum wire size	0.30 mm <sup>2</sup> (22 AWG)
Maximum wire size	2.1 mm <sup>2</sup> (14 AWG)
Maximum torque	1.36 N-m (12 lb.-in.)
Wire type	Use only copper wire

### Grounding the Safety Ground (PE)

Most codes require a safety ground. You can connect the ground bus to adjacent building steel (such as a girder or joist) or a floor ground loop, provided that the grounding points comply with your national (such as NEC), regional, or local regulations.

## Grounding the Optional RFI Filter

If you are using an RFI filter, you must solidly ground the RFI filter.

**Important:** Using an optional RFI filter may result in relatively high ground leakage currents. The filter incorporates surge suppression devices to clamp line surges to a limited voltage above ground potential. Therefore, you must permanently install and solidly ground the filter. Grounding must not rely on flexible cables and should not include any form of plug or socket that would permit inadvertent disconnection. You should periodically check the integrity of this connection.



*Additional information about the optional RFI filter is located in Appendix E, CE Conformity.*

## Wiring the Power

The input and output power connections are different between the different frame sizes.

If you have this frame size:	Refer to this chapter:
A1, A2, A3, or A4	Chapter 3
B, C, D, E, F, G, or H	Chapter 4

The following table provides generic terminal information.

Terminal	Description
PE	Power earth ground
R (L1), S (L2), T (L3)	AC line input terminals
+DC, -DC	DC bus terminals
U (T1), V (T2), W (T3)	Motor connection



**ATTENTION:** The national codes and standards (such as NEC, VDE, and BSI) and local codes outline provisions for safely installing electrical equipment. Installation must comply with specifications regarding wire type, conductor sizes, branch circuit protection, and disconnect devices. Failure to do so may result in personal injury and/or equipment damage.

**Important:** For maintenance and set up procedures, you may operate the drive without having a motor connected.

The following table provides information about the maximum/minimum wire size and maximum torque used for the various frame sizes.

If you have this frame size:	The maximum/minimum wire size <sup>1</sup> in mm <sup>2</sup> (AWG) is:	The maximum torque in N-m (lb.-in.) is:
A1 – A4	5.3/0.8 (10/18)	1.81 (16)
B	8.4/0.8 (8/18) 13.3/0.5 (6/20)	1.81 (16) 1.70 (15)
C	26.7/0.8 (3/18)	5.65 (50)
D <sup>2</sup>	127.0/2.1 (250 MCM/14) 67.4/2.1 (00/14) <sup>3</sup>	6.00 (52) 6.00 (52)
E <sup>2</sup>	253.0/2.1 (500 MCM/14)	10.00 (87)
F <sup>2</sup>	303.6/2.1 (600 MCM/14)	23.00 (200)
G <sup>2</sup>	303.6/2.1 (600 MCM/14)	23.00 (200)
H <sup>2</sup>	303.6/2.1 (600 MCM/14)	23.00 (200)

1 Wire sizes given are the maximum/minimum sizes that TB1 will accept. These are not recommendations.

2 These configurations of TB1 are stud type terminations and require the use of lug type connectors to terminate field installed conductors. Lug kits are available for use with these configurations. Wire size used is determined by selecting the proper lug kit based on the drive catalog number. Refer to Chapter 4 for information on lug kits.

3 Applies to 30 kW (40 hp) 200 – 240V, 45 and 56 kW (60 and 75 hp) 380 – 480V, 56 kW (75 hp) 500 – 600V drives only.

The drive connections are frame specific. Refer to the appropriate chapter for the drive connections.

## Selecting Your Motor Cables

You can select which type of cable you want to use with the 1336 IMPACT drive.

### Unshielded Cable

For many installations, you can use unshielded cable as long as you can separate it from sensitive circuits. As an approximate guide, allow a spacing of 1 meter (3.3 feet) for every 10 meters (33 feet) of length. In all cases, you need to avoid long parallel runs.

Unshielded cable should be 4-conductor with the ground lead connected directly to the drive ground terminal (PE) and the motor frame ground terminal.

### Shielded Cable

You should use shielded cable if sensitive circuits or devices are connected or mounted to the machinery driven by the motor. You must connect the shield to the drive chassis. Make the connection at both ends to minimize the external magnetic field.

If you use cable trays or large conduits to distribute the motor leads for multiple drives, use shielded cable to reduce or capture the noise from the motor leads and to minimize cross coupling of noise between the leads of different drives. Connect to the ground (PE) connections at both the motor and the drive end.

Some installations require armored cable instead of shielded cable. Refer to the following table:

Condition:	Insulation Type:	Example:
Dry	PVC <sup>1</sup>	THHN
	XLPE	XHHW-2
Wet	XLPE	XHHW-2

<sup>1</sup> For input voltages in excess of 230 V AC, motor cables greater than 15 m (50 ft), or wire with less than 15 mil of insulation, wire with XLPE insulation is recommended. Contact Rockwell Automation if you have questions.

### Armored Cable

Armored cable also provides effective shielding. Ideally, you should ground armored cable only at the drive (PE) and motor frame. Some armored cable has a PVC coating over the armor to prevent incidental contact with grounded structure. If, due to the type of connector, you must ground the armor at the cabinet entrance, use shielded cable within the cabinet to continue as far as possible with the coaxial arrangement of power cable and ground.

In some hazardous environments, you cannot ground both ends of the cable armor. This is because of the possibility of high current circulating at the input frequency if the ground loop is cut by a strong magnetic field. This only applies in the proximity of powerful electrical machines. In this case, make the ground connection at one end through a capacitance that blocks the low, line frequency current but presents a low impedance to RF. Due to the highly pulsed nature of the circulating current, the capacitor type used must be rated for AC-to-ground voltage. Consult the factory for specific guidelines.

### Conduit

If you use metal conduit for cable distribution, use these guidelines:

- Drives are normally mounted in cabinets, and ground connections are made at a common ground point in the cabinet. If the conduit is connected to the motor junction box and the drive end, you do not need any additional conduit connections.
- Route no more than three sets of motor leads through a single conduit. This minimizes cross talk that could reduce the effectiveness of the noise reduction methods described. If more than three drive/motor connections per conduit are required, use shielded cable. If practical, each conduit should contain only one set of motor leads.

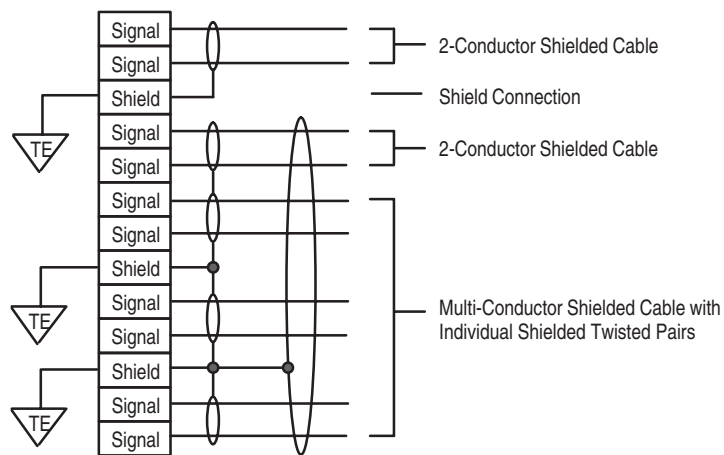


**ATTENTION:** To avoid a possible shock hazard caused by induced voltages, ground unused wires in the conduit at both ends. For the same reason, if a drive sharing a conduit is being serviced or installed, disable all drives using this conduit to eliminate the possible shock hazard from cross coupled drive motor leads.

Observe all applicable safety and national and local regulations when selecting the appropriate wire size for your system. Due to the drive overload capacity, the conductors for the transformer primary and secondary must be sized (at a minimum) for 125% of the maximum motor current. The motor conductors must also be rated for 125% of the full load motor current. The distance between the drive and motor may affect the size of the conductors used.

To protect against interference, use shielded type wire in control circuits. A shielded wire is required for all signal wires. The recommended conductor size must be a minimum of  $0.82\text{mm}^2$  (16 AWG). The best interference suppression is obtained with a wire having an individual shield for every twisted pair. Figure 2.4 shows the recommended cable shielding.

**Figure 2.4**  
**Cable Shielding Recommendations**



### By-Pass Contactors

Please read the following Attention regarding by-pass contactors.



**ATTENTION:** An incorrectly applied or installed system can result in component damage or reduction in product life. The most common causes are:

- Wiring AC line to drive output or control terminals.
- Improper by-pass or output circuits not approved by Allen-Bradley.
- Output circuits which do not connect directly to the motor.
- Incorrect or inadequate AC supply.
- Excessive ambient temperature.

Contact Allen-Bradley for assistance with application or wiring.

## Hard Wiring Your I/O

Before you can transfer data to or from the drive, you need to hard wire the analog inputs, the analog outputs, the output relays, and the L Option (optional). The terminal block locations for the reference signal connections are in the frame-specific chapters.

The terminal blocks accept wire with the following specifications:

Wire information	Description
Minimum wire size	0.06 mm <sup>2</sup> (30 AWG)
Maximum wire size	3.3 mm <sup>2</sup> (12 AWG)
Maximum torque	0.79 N-m (7 lb.-in.)

Recommended control signal wire is:

This Belden wire or equivalent:	Should have these specifications:
8760	0.750 mm <sup>2</sup> (18 AWG), twisted pair, shielded
8770	0.750 mm <sup>2</sup> (18 AWG), 3-conductor, shielded
9460	0.750 mm <sup>2</sup> (18 AWG), twisted pair, shielded

The location of the terminal blocks is frame specific. Refer to the appropriate chapter (Chapter 3 or 4) for the location of your terminal blocks.



**ATTENTION:** If you install control and signal wiring with an insulation rating of less than 600V, route this wiring inside the drive enclosure to separate it from any other wiring and uninsulated live parts. If you do not separate these wires, you may damage your equipment or have unsatisfactory drive performance.

## Connecting the Analog Inputs

The 1336 IMPACT drive has the following analog inputs:

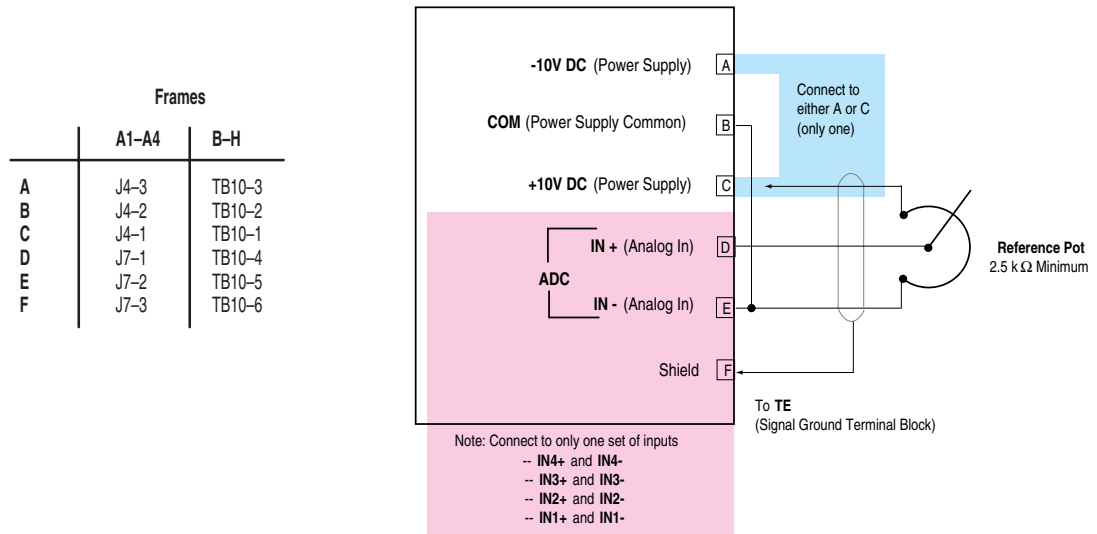
Quantity	Description	Input impedance
2	Range of $\pm 10V$	20K Ohms
1	4 – 20 mA	130 Ohms

These inputs are differential inputs with noise rejection filtering. Each input has a gain and offset adjustment. The A/D converter is a 12-bit device where an input value of +10V results in a digital value of 2048. Likewise, an input value of -10V results in a digital output value of -2048.

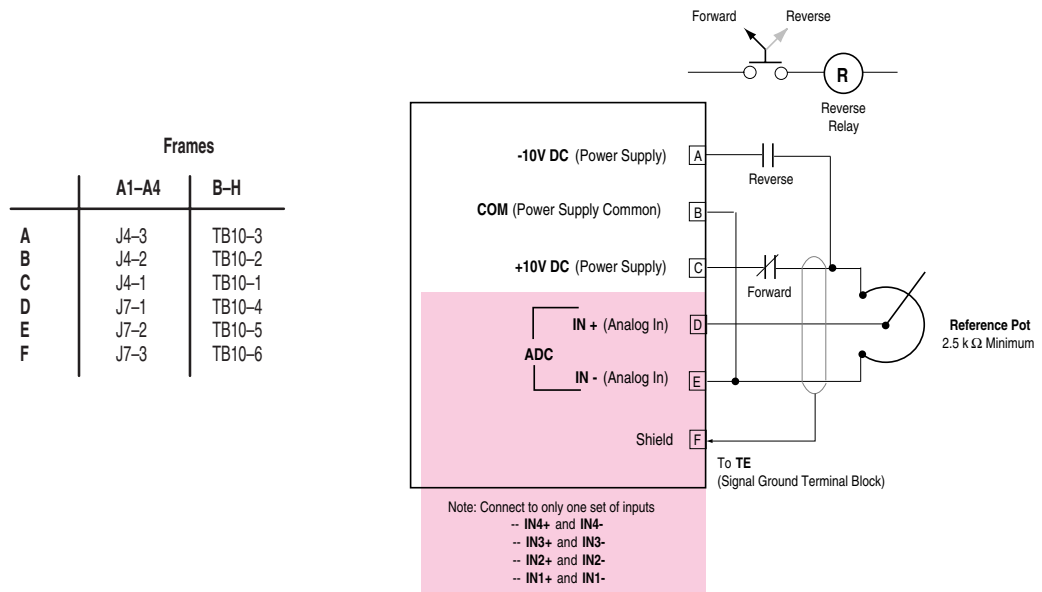


*For an analog input to function, you must link the analog input parameters to an appropriate drive parameter as well as define the scaling and offset parameters.*

The typical analog input connections for unidirectional operation are shown as follows:



The typical analog input connections for bidirectional operation can be shown as follows:



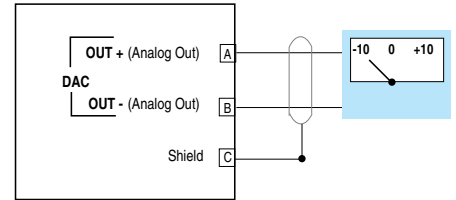
► *If you are wiring a remote pot to your system, you may want to refer to Chapter 9, Applications, and Appendix B, Control Block Diagrams, for additional information.*



### Analog Outputs

There are two analog outputs that have a range of  $\pm 10V$  and one 4 – 20mA output with a digital resolution of 12 bits. The typical analog output connections can be shown as follows:

Quantity	Description	
2	+10V	Impedance 100 ohms 10mA maximum
1	4-20mA	Impedance 273 ohms



### Discrete Outputs

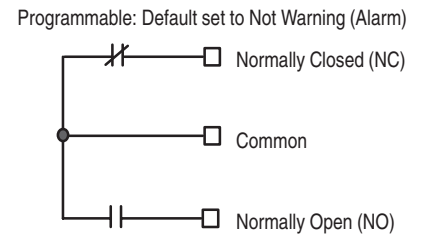
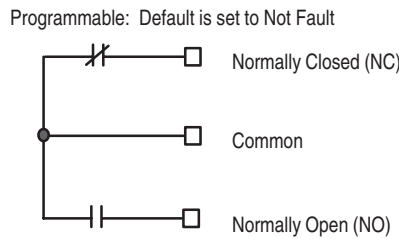
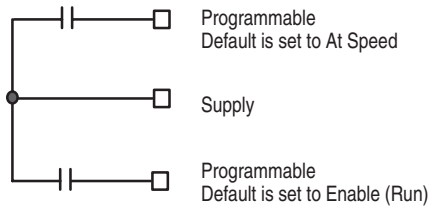
Fault outputs from the 1336 IMPACT drive are supplied at terminal blocks. Fault outputs provide warning or fault signals based on drive programming. Refer to the frame-specific chapters for additional information about the terminal blocks available for your frame size.

The following values are the contact ratings for the programmable relays:

- 2A at 115V AC
- 2A at 30V DC

Figure 2.5 shows the typical digital output connections.

**Figure 2.5**  
**Typical Digital Output Connections**



### Pulse Input

The pulse input is a differential input that lets an external source provide the drive with a digital reference or trim signal. The pulse input has the following specifications:

Specification	Description
Voltage rating	5 or 12V
Maximum frequency	100 kHz
Minimum mA	10

### Auxiliary Output - TB9

The 480V or 600V (depending on the input voltage to the drive) output terminal block (TB9) is only available on F Frame Drives. This terminal block provides a three-phase, high voltage connection from the load side of the AC input line fuses.

Normally this connection is used to power an external control transformer (user supplied) or an auxiliary circuit.

**Important:** Depending on the circuitry connected, additional fusing may be required.



**ATTENTION:** The installation of auxiliary circuits must comply with the national codes and standards (NEC, VDE, BSA, etc.) and local codes regarding wire type, conductor sizes, branch circuit protection and disconnect devices. Failure to do so may result in personal injury and/or equipment damage.

---

The auxiliary circuit can be utilized to a maximum current capacity of 8 amperes RMS.

The maximum and minimum wire size accepted by TB9 is 4.0 and 0.8 mm<sup>2</sup> (12 and 18 AWG). Use Copper wire Only with a minimum temperature rating of 75 degrees C. Maximum torque is 0.90-1.81 Nm (8 - 16 lb-in.).

## Connecting Your Gateway

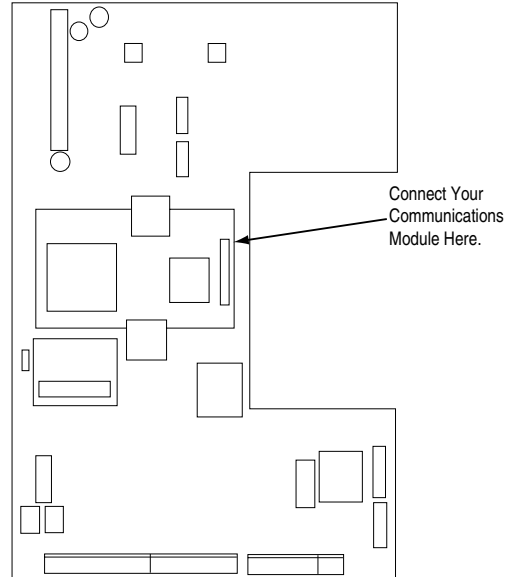
If you have a B – H frame drive, you can connect the 1336 IMPACT drive to a network using either an isolated gateway such as a GD1 or GD2 communications module or an internal gateway such as a GM1 or GM2 communications module.

If you have an A1 – A4 frame, you can connect the 1336 IMPACT drive to a network using an isolated gateway.

If you are using an isolated gateway, connect the module to the drive by plugging the communications module cable into the bottom of the drive.

If you are using an internal gateway, connect the module to the drive at the connector labeled *GATEWAY* on your board.

**Figure 2.6**  
**Gateway Connection Location**



Refer to the documentation that came with your gateway for installation information.

If you need additional SCANport connections, the 1203-SG2 and 1203-SG4 SCANport expanders are available.

## Installing an Interface Board

If you are using an L Option board, refer to Chapter 5, *Using the L Option*, for installation instructions. The terminal blocks used to connect the L Option board accept wire with the following specifications:

Wire information	Description
Minimum wire size	0.06 mm <sup>2</sup> (30 AWG)
Maximum wire size	3.3 mm <sup>2</sup> (12 AWG)
Maximum torque	0.79 N-m (7 lb.-in.)
Wire type	Use only copper wire

## Connecting the Power to the Drive

### AC Supply Source

1336 IMPACT drives are suitable for use on a circuit that can deliver up to a maximum of 200,000 rms symmetrical amperes when used with the AC input line fuses specified in the tables in the frame-specific chapters.

The 1336 IMPACT drive does not contain input power short circuit fusing. Specifications for the recommended size and type to provide drive input power protection against short circuits are on the following pages.



**ATTENTION:** To guard against personal injury and/or equipment damage caused by improper fusing, use only the recommended line fuses specified in the tables in the frame-specific chapters. Branch circuit breakers or disconnect switches cannot provide this level of protection for drive components.

### Unbalanced Distribution Systems

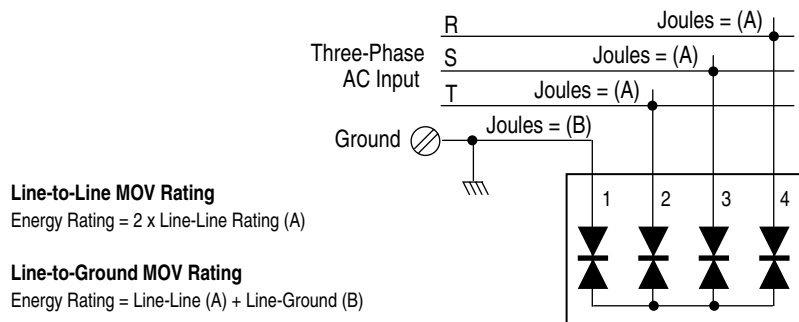
The drive is designed for use with conventional three-phase supplies that are symmetrical with respect to ground. Surge suppression devices are included to protect the drive from lightning-induced overvoltages between line and ground. For this reason, we recommend a neutral grounded system. The drive works with a grounded phase, but you may want to use an isolation transformer to provide a supply balanced with respect to ground.

### Ungrounded Distribution Systems

All 1336 IMPACT drives are equipped with a MOV (Metal Oxide Varistor). The MOV provides surge voltage protection and phase-to-phase plus phase-to-ground protection which is designed to meet IEEE 587. The MOV circuit is designed for surge suppression only (transient line protection), not continuous operation.

With ungrounded distribution systems, the phase-to-ground MOV connection could become a continuous current path to ground. MOV line-to-line and line-to-ground voltages should not exceed the input voltage rating shown in Appendix A, *Specifications*. Exceeding these values may cause physical damage to the MOV.

**Figure 2.7**  
**MOV Ratings**



**Line-to-Line MOV Rating**  
Energy Rating = 2 x Line-Line Rating (A)

**Line-to-Ground MOV Rating**  
Energy Rating = Line-Line (A) + Line-Ground (B)

Frame Reference	A	B - C	D - H
Device Rating (V)	240 480 600	240 480 600	240 480 600
Line-Line (A)	160 140 NA	160 160 160	140 140 150
Line-Ground (B)	220 220 NA	220 220 220	220 220 220

## Is a Line Reactor or Isolation-Type Transformer Required?

Typically, you can connect the 1336 IMPACT drive directly to a three-phase AC power line. However, certain power line conditions may introduce the possibility of drive input power component malfunction. To reduce the possibility of these malfunctions, a line reactor or isolation-type transformer may be required.

Use the following table to determine if a line reactor or isolation-type transformer is required for your system:

If the AC line supplying the drive:	Then an AC line reactor or isolation-type transformer:
Has power factor correction capacitors connected and switched	Is recommended between the capacitor bank and the input to the drive.
Frequently experiences transient power interruptions or significant voltage spikes	May be required.
Is run off the same line as a line commutated DC drive	May be required

## Input Fusing



**ATTENTION:** The 1336 IMPACT drive does not provide input power short circuit fusing. Specifications for the recommended fuse size and type to provide drive input power protection against short circuits is provided in the tables in the frame-specific chapters. Branch circuit breakers or disconnect switches cannot provide this level of protection for drive components.

The input fusing requirements are frame-size specific. Please refer to the appropriate chapter.

## Disconnecting the Drive Output

Any method of disconnecting the drive that you wire to drive output terminals M1, M2, and M3 must be able to disable the drive if opened during drive operation. If opened during drive operation, the drive may fault. You should remove the Drive Enable before the contactor is opened. When the Drive Enable is removed, the drive stops modulating.

## Starting and Stopping the Motor



**ATTENTION:** The 1336 IMPACT drive control circuitry includes solid-state components. If hazards due to accidental contact with moving machinery or unintentional flow of liquid, gas, or solids exists, an additional hardwired stop circuit may be required to remove AC line power to the drive. When AC input power is removed, there is a loss of inherent regenerative braking effect and the motor coasts to a stop. An auxiliary braking method may be required.

## Electrical Interference — EMI/RFI

### Immunity

The immunity of 1336 IMPACT drives to externally generated interference is good. Usually, no special precautions are required beyond the installation practices provided in this manual.

You should suppress the coils of DC energized contactors associated with drives with a diode or similar device, because they can generate severe electrical transients.

In areas subject to frequent lightning strikes, additional surge suppression is advisable. You should use suitable MOVs connected between each line and ground. Refer to Figure 2.7 for additional information about MOVs.

### Emission

To avoid interference with nearby sensitive equipment, you must be careful about how you arrange the power and ground connections to the drive. Route the cable that goes to the motor well away from sensitive equipment, as the motor cable does carry switched voltages.

Connect the ground conductor of the motor cable to the drive ground (PE) terminal directly. Connecting this ground conductor to a cabinet ground point or ground bus bar may cause high frequency current to circulate in the ground system of the enclosure. You must solidly connect the motor end of this ground conductor to the motor case ground.

You may use shielded or armored cable to guard against radiated emissions from the motor cable. Connect the shield or armor to the drive chassis.

Common mode chokes are recommended at the drive output to reduce the common mode noise. An RFI filter can be used and in most situations provides an effective reduction of RFI emissions that may be conducted into the main supply lines.

If the installation combines a drive with sensitive devices or circuits, program the lowest possible drive PWM frequency.

## Do I Need an RFI Filter?

You can install 1336 IMPACT drives with an RFI filter. The RFI filter controls radio-frequency conducted emissions into the main supply lines and ground wiring. If you follow the cabling and installation instructions described in this manual, interference problems are unlikely when the drive is used with conventional industrial electronic circuits and systems.

You should use the optional RFI filter if:

- You must conform to a standard such as EN 55011, VDE0875, BSI, or FCC.
- You need to achieve very low emission levels.
- You are installing sensitive devices or circuits on the same AC supply.
- The motor cable exceeds 50 meters (164 feet). Beyond this length, capacitance to ground increases the supply emissions.

---

**Important:** The conformity of the drive and filter to any standard does not assure that the entire installation conforms. Other factors can influence the total installation and only direct measure can verify total conformity.

### Installing an RFI Filter

To install the RFI filter, follow the instructions provided with the filter. In addition, you should note the following information:

- Connect the RFI filter between the incoming AC supply line and the drive power input terminals.
- Install the filter on the same mounting plate as the drive, if possible. The filter should be physically close to the drive with short connections.

**Important:** To assure that the RFI filter is effective, you must shield or armor the motor cable and follow the guidelines given in this manual.

### RFI Filter Leakage Current

The optional RFI filter may cause ground leakage currents. Therefore, you must provide an appropriate ground connection (refer to the grounding instruction on page 2-14).



**ATTENTION:** To guard against possible equipment damage, you can only use RFI filters with AC supplies that are nominally balanced with respect to ground. In some countries, three-phase supplies are occasionally connected in a 3-wire configuration with one phase grounded (Grounded Delta). The filter must not be used in Ground Delta supplies.

---

**Notes:**



## Mounting and Wiring Information Specific to Frames A1, A2, A3, and A4

### Chapter Objectives

Chapter 3 provides the mounting and wiring information specific to frames A1, A2, A3, and A4.

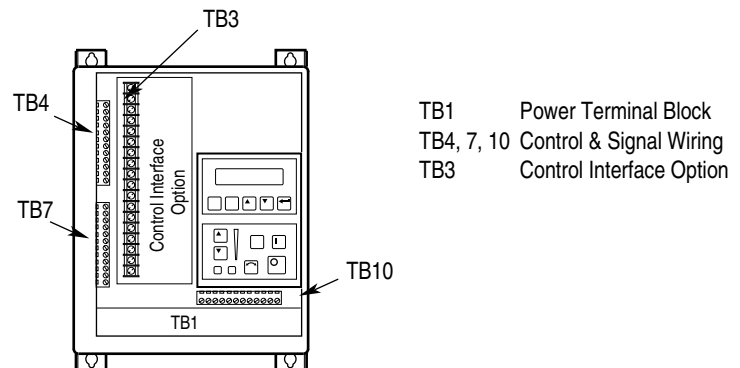
This Topic:	Starts on Page:
Wiring the power	3-1
Hard wiring your I/O	3-3
Input fusing requirements	3-4
Dimensions	3-5

**Important:** If your 1336 IMPACT drive is not an A1 – A4 frame size, skip this chapter and read the mounting and wiring instructions specific to your frame size. If you do not know what your frame size is, refer to Chapter 1, *Overview*.

### Wiring the Power

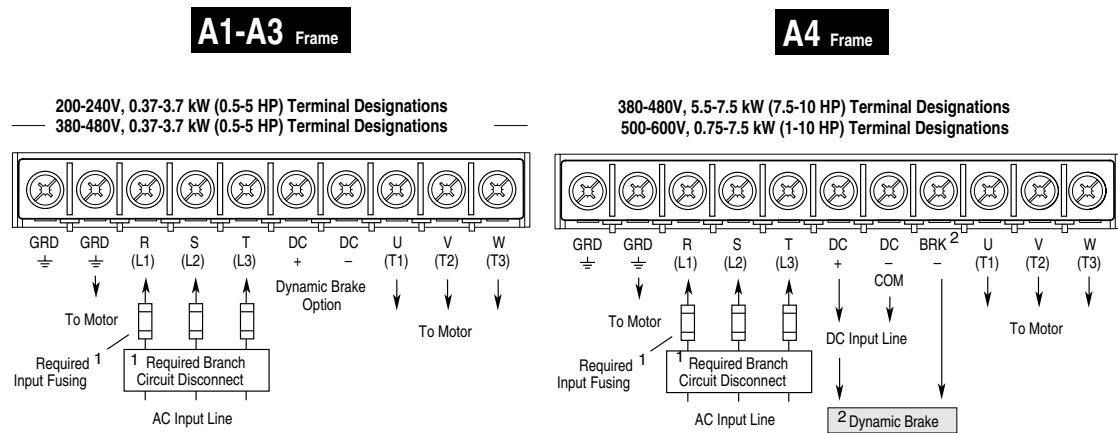
The input and output connections for frames A1 – A4 are shown in Figure 3.1.

**Figure 3.1**  
**Terminal Block Locations**



The drive connections for TB1 are shown in Figure 3.2.

**Figure 3.2**  
**Drive Connections for Frames A1 – A4**



1 User supplied.

2 Before wiring your dynamic brake for the A4 frame, double check the terminals. You should attach the + terminal on the brake to the DC+ terminal on your drive and the - terminal on the brake to the BRK - terminal on your drive. If your BRK - terminal is labeled VBUS -, connect the - terminal on the brake to the VBUS - terminal on your drive.

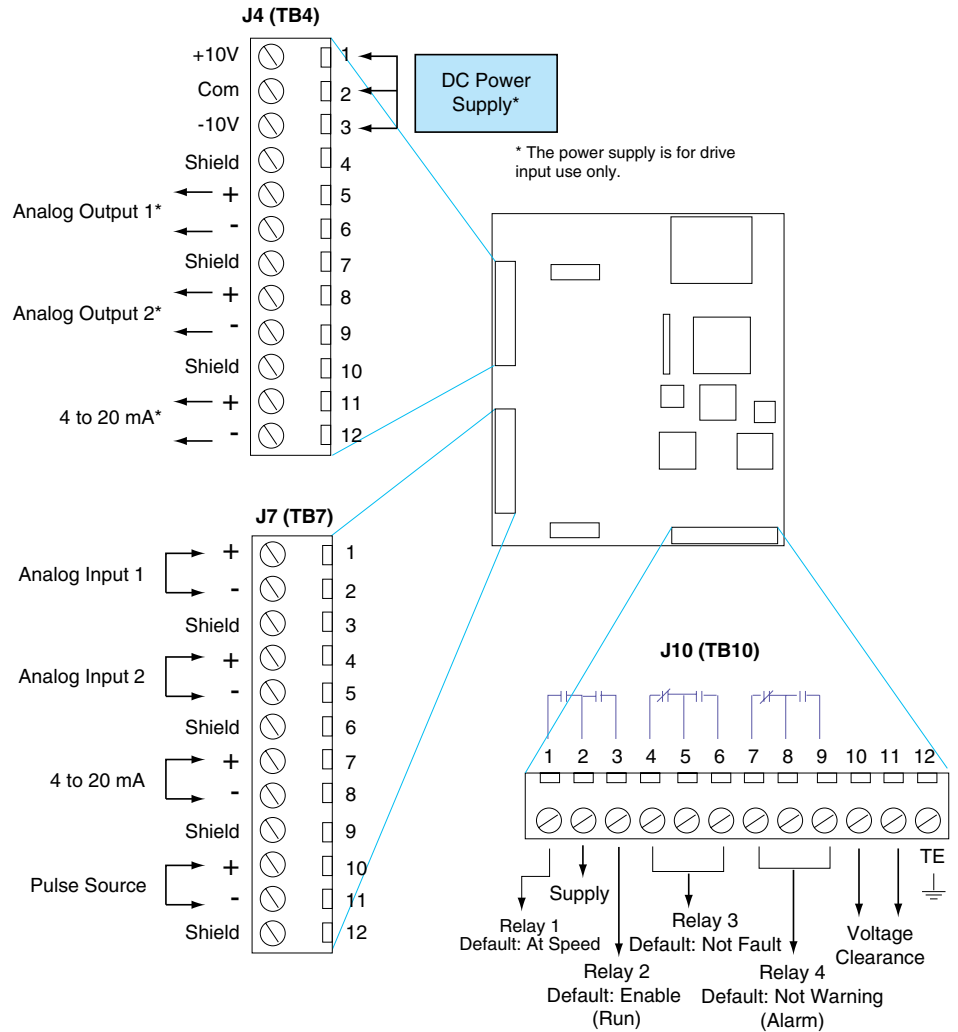


**ATTENTION:** If you install control and signal wiring with an insulation rating of less than 600V, route this wiring inside the drive enclosure to separate it from any other wiring and uninsulated live parts. If you do not separate these wires, you may damage your equipment or have unsatisfactory drive performance.

## Hard Wiring Your I/O

You can use terminal blocks TB4, TB7, and TB10 for hardwiring your I/O. These terminal blocks are shown in Figure 3.3.

**Figure 3.3**  
**Reference Signal Connections**



\*NOTE: Analog I/O is differential, non-isolated I/O.  
A (-) negative does not indicate common.

The terminal blocks provide the following:

This Terminal Block:	Provides these Terminal Numbers:	Which Provide Access to this Signal:	
TB4	4, 7, 10	Shield ground	
	1, 2, 3	DC power supply	±10V DC 50 mA per voltage
	5, 6, 8, 9	0 to ±10V DC output	Output impedance = 100 Ohms; 10mA maximum
	11, 12	4 – 20 mA DC output	Output impedance = 20 Ohms
TB7	3, 6, 9, 12	Shield Ground	
	1, 2, 4, 5	0 to ±10V DC input	Input impedance = 20K Ohms
	7, 8	4 – 20 mA input	Input impedance = 130 Ohms
	10, 11	Pulse input for frequency reference +5V DC — Jumper J8 Set to 1 – 2 +12V DC — Jumper J8 Set to 2 – 3 Scale Factor (Pulse PPR) must be set 10mA minimum	
TB10	12	Logic Earth Ground, Shield	
	1, 2, 3, 4, 5, 6, 7, 8, 9	Programmable contacts Resistive rating = 115VAC/30VDC, 5.0A Inductive rating = 115VAC/30VDC, 2.0A	
	10, 11	Voltage clearance. Provides physical space between the logic earth ground and other signals on the terminal block.	

## Input Fusing Requirements

The following are the input fusing requirements for frames A1 – A4.

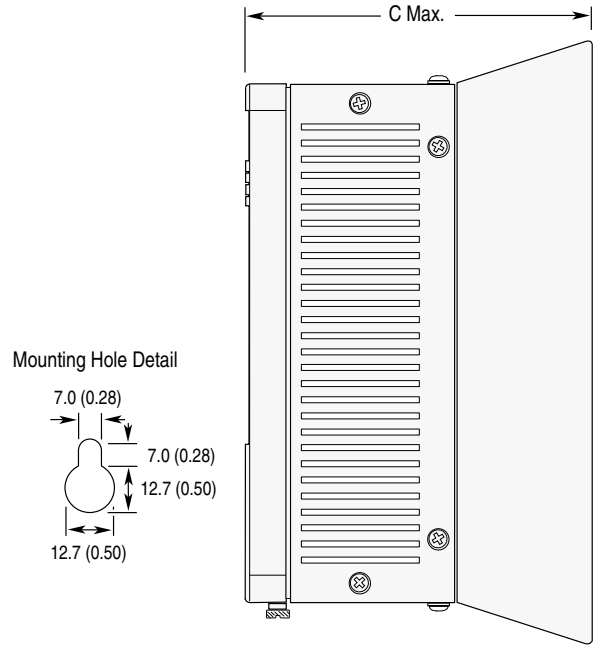
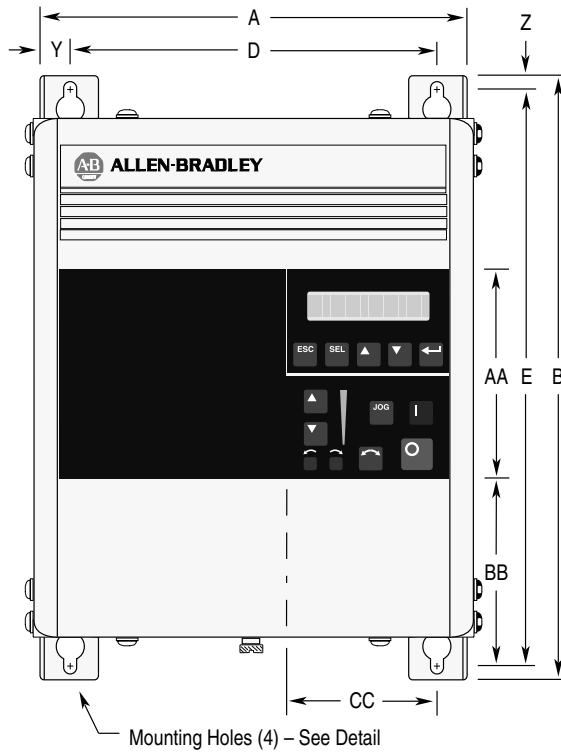
Maximum Recommended AC Input Line Fuse Ratings (Fuses are User Supplied)

European Installations	North American Installations	Drive Catalog Number	kW (HP) Rating	200 – 240V Rating	380 – 480V Rating	500 – 600V Rating
<p>The recommended fuse is Class gG general industrial applications and motor circuit protection.</p> <p>BS88 (British Standard) Parts 1 &amp; 2*, EN60269-1, Parts 1 &amp; 2, type gG or equivalent should be used for these drives. Fuses that meet BS88 Parts 1 &amp; 2 are acceptable.</p> <p>* Typical designations include, but may not be limited to the following: Parts 1 &amp; 2: AC, AD, BC, BD, CD, DD, ED, EFS, EF, FF, FG, GF, GG, GH</p>	<p>UL requirements specify that UL Class CC, T, or J<sup>1</sup> fuses must be used for all drives in this section*.</p> <p>* Typical designations include: Type CC: KTK, FNQ-R Type J: JKS, LPJ Type T: JJS, JJN</p>	1336E-__ F05, 07	0.37 – 0.56 (0.5 – 0.75)	6A	3A	—
		1336E-__ F10	0.75 (1)	10A	6A	3A
		1336E-__ F15	1.2 (1.5)	15A	6A	—
		1336E-__ F20	1.5 (2)	15A	10A	6A
		1336E-__ F30	2.2 (3)	25A	15A	10A
		1336E-__ F50	3.7 (5)	40A	20A	10A
		1336E-__ F75	5.5 (7.5)	—	20A	15A
		1336E-__ F100	7.5 (10)	—	30A	20A

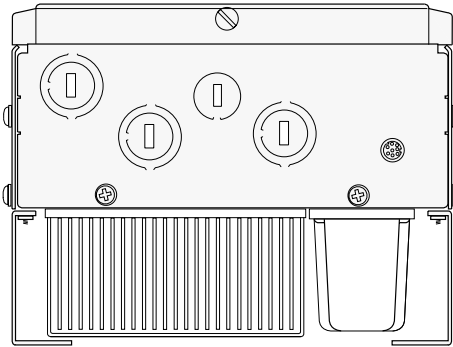
1 Both fast acting and slow blow are acceptable.

**Dimensions**

The following shows the dimensions for frames A1 – A4.



Bottom View Will Vary with HP – See *Bottom View Dimensions*

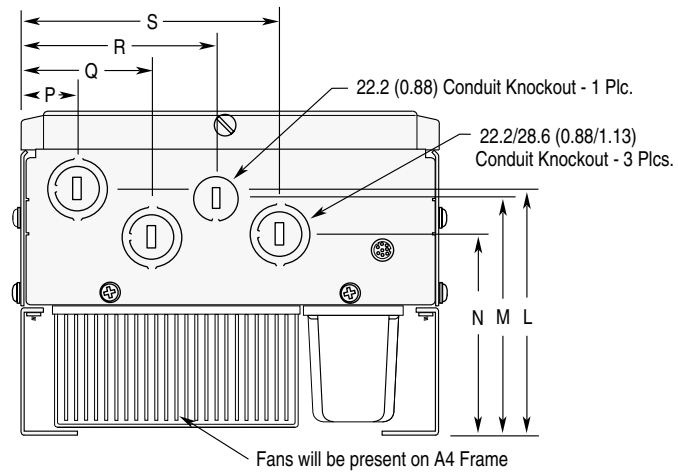


Three-Phase Rating			Frame Reference
200 – 240V	380 – 480V	500 – 600V	
0.37 – 0.75 kW 0.5 – 1 HP	0.37 – 1.2 kW 0.5 – 1.5 HP	—	A1
1.2 – 1.5 kW 1.5 – 2 HP	1.5 – 2.2 kW 2 – 3 HP	—	A2
2.2 – 3.7 kW 3 – 5 HP	3.7 kW 5 HP	—	A3
—	5.5 – 7.5 kW 7.5 – 10 HP	*0.75 – 7.5 kW 1 – 10 HP	A4
5.5 – 11 kW 7.5 – 15 HP	11 – 22 kW 15 – 30 HP	*11 – 15 kW 15 – 20 HP	B
15 – 22 kW 20 – 30 HP	30 – 45 kW 40 – 60 HP	18.5 – 45 kW 25 – 60 HP	C
30 – 45 kW 40 – 60 HP	45 – 112 kW 60 – 150 HP	56 – 93 kW 75 – 125 HP	D
56 – 93 kW 75 – 125 HP	112 – 187 kW 150 – 250 HP	112 – 187 kW 150 – 250 HP	E
—	187 – 448 kW 250 – 600 HP	224 – 448 kW 300 – 600 HP	G

\* Use care when choosing Frame Reference — some ratings may exist in another frame size.

Frame Reference	A	B	C Max.	D	E	Y	Z	AA	BB	CC	Shipping Weight
A1	215.9 (8.50)	290.0 (11.42)	160.0 (6.30)	185.2 (7.29)	275.0 (10.83)	15.35 (0.60)	7.5 (0.30)	130.0 (5.12)	76.2 (3.00)	85.3 (3.36)	4.31 kg (9.5 lbs.)
A2	215.9 (8.50)	290.0 (11.42)	180.5 (7.10)	185.2 (7.29)	275.0 (10.83)	15.35 (0.60)	7.5 (0.30)	130.0 (5.12)	76.2 (3.00)	85.3 (3.36)	5.49 kg (12.1 lbs.)
A3	215.9 (8.50)	290.0 (11.42)	207.0 (8.15)	185.2 (7.29)	275.0 (10.83)	15.35 (0.60)	7.5 (0.30)	130.0 (5.12)	76.2 (3.00)	85.3 (3.36)	6.71 kg (14.8 lbs.)
A4	260.0 (10.24)	350.0 (13.78)	212.0 (8.35)	230.0 (9.06)	320.0 (12.60)	15.35 (0.60)	15.35 (0.60)	130.0 (5.12)	133.0 (5.23)	86.0 (3.39)	15.90 kg (35.0 lbs.)

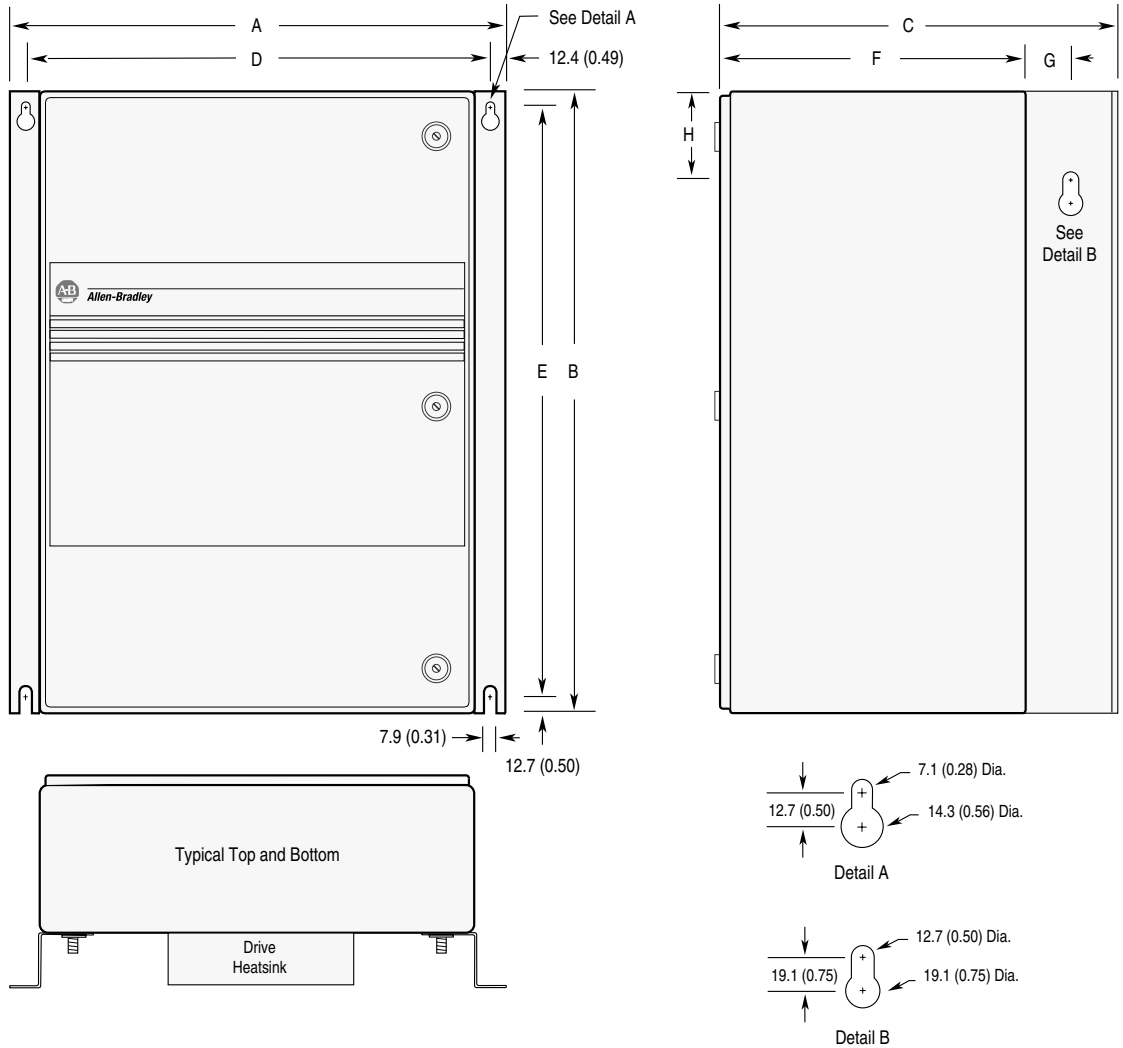
## Frames A1 through A4



Frame Reference	L	M	N	P	Q	R	S
A1	111.8 (4.40)	105.4 (4.15)	86.3 (3.40)	25.4 (1.00)	63.2 (2.49)	102.1 (4.02)	135.4 (5.33)
A2	132.3 (5.21)	126.0 (4.96)	106.9 (4.21)	25.4 (1.00)	63.2 (2.49)	102.1 (4.02)	135.4 (5.33)
A3	158.8 (6.25)	152.4 (6.00)	133.4 (5.25)	25.4 (1.00)	63.2 (2.49)	102.1 (4.02)	135.4 (5.33)
A4	164.0 (6.45)	164.0 (6.45)	139.0 (5.47)	27.0 (1.06)	65.0 (2.65)	97.0 (3.82)	128.7 (5.07)

*All Dimensions in Millimeters and (Inches).*

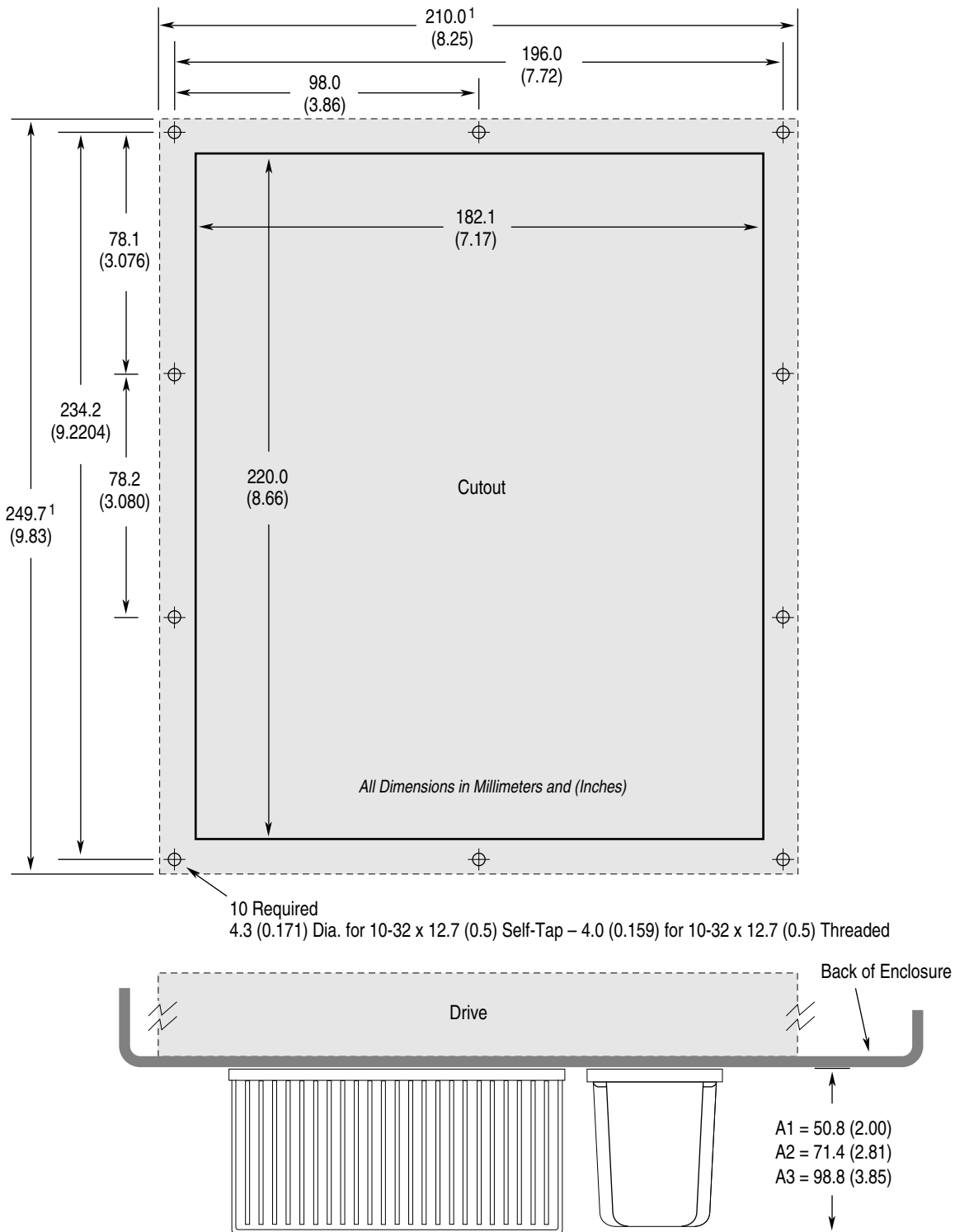
The following are the dimensions for the IP65/54 (NEMA 4/12) enclosures.



All Dimensions in Millimeters and (Inches).

Frame Reference	A	B	C	D	E	F	G	H	Approx. Ship Weight
A1	430.0 (16.93)	525.0 (20.67)	350.0 (13.78)	404.9 (15.94)	500.1 (19.69)	250.0 (9.84)	N/A	N/A	16.8 kg (37.0 lbs.)
A2	430.0 (16.93)	525.0 (20.67)	350.0 (13.78)	404.9 (15.94)	500.1 (19.69)	250.0 (9.84)	N/A	N/A	17.9 kg (39.4 lbs.)
A3	430.0 (16.93)	525.0 (20.67)	350.0 (13.78)	404.9 (15.94)	500.1 (19.69)	250.0 (9.84)	N/A	N/A	18.6 kg (41.0 lbs.)
A4	655.0 (25.79)	650.0 (25.59)	425.0 (16.74)	629.9 (24.80)	625.1 (24.61)	293.0 (11.54)	63.5 (2.50)	76.2 (3.00)	39.5 kg (87.0 lbs.)

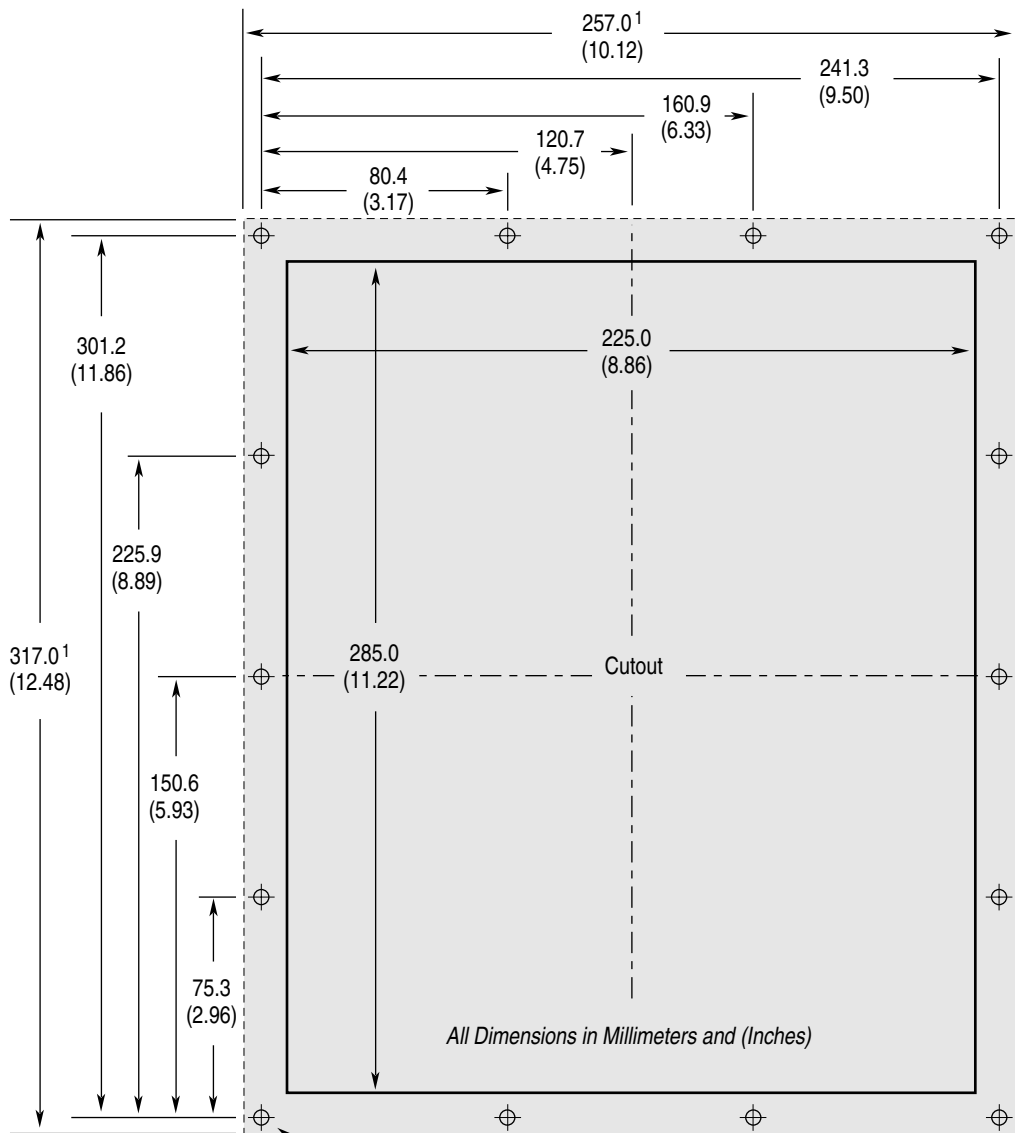
Heat Sink Through-the-Back Mounting - Frames A1 through A3



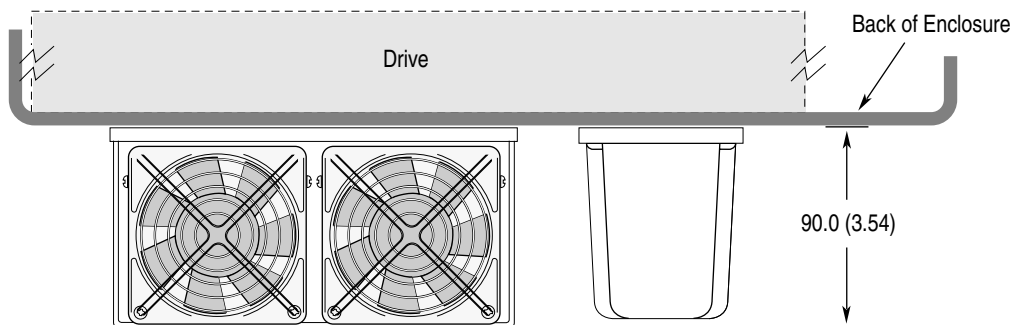
<sup>1</sup> Shading indicates **approximate** size of drive inside enclosure.



Heat Sink Through-the-Back Mounting - Frame A4



14 Required  
4.3 (0.171) Dia. for 10-32 x 12.7 (0.5) Self-Tap – 4.0 (0.159) for 10-32 x 12.7 (0.5) Threaded



<sup>1</sup> Shading indicates **approximate** size of drive inside enclosure.

**Notes**

## Mounting and Wiring Information Specific to Frames B, C, D, E, F, G, and H

### Chapter Objectives

Chapter 4 provides the mounting and wiring information specific to frames B – H.

This Topic:	Starts on Page:
Wiring the power	4-1
Selecting the proper lug kit for your system	4-6
Hard wiring your I/O	4-8
Selecting/verifying fan voltage	4-10
Input fusing requirements	4-11
Dimensions	4-12

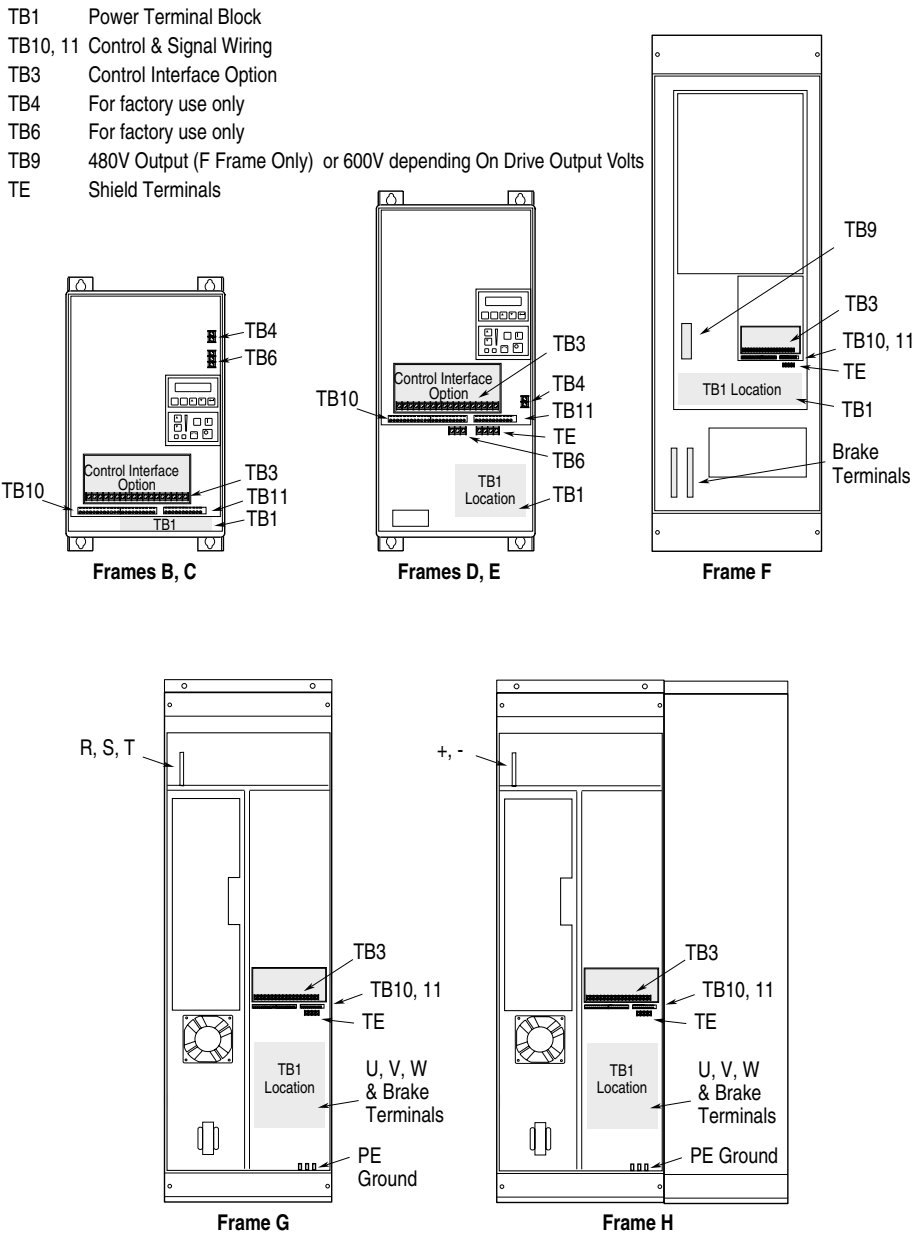
**Important:** If your 1336 IMPACT drive is not a B – H frame size, skip this chapter and read the mounting and wiring instructions specific to your frame size. If you do not know what your frame size is, refer to Chapter 1, *Overview*.

### Wiring the Power

The location of the input and output connections depend on the size of your drive:

If your drive is:	Then, the input and output connections need to be made:
15 to 30 hp	Through an 11-position terminal block, TB1, located on the Gate Driver Board.
Over 30 hp	At separate terminal strips located at the bottom of the drive.

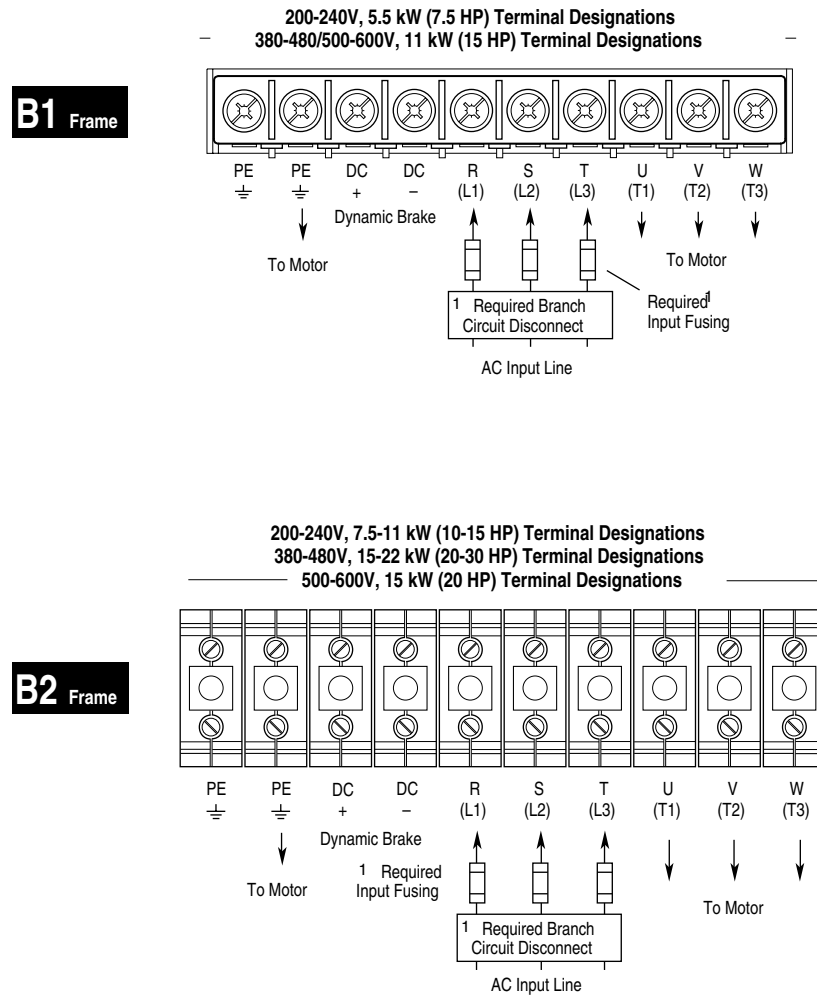
**Figure 4.1**  
**Terminal Block Locations**



**ATTENTION:** The national codes and standards (such as NEC, VDE, and BSA) and local codes outline provisions for safely installing electrical equipment. Installation must comply with specifications regarding wire type, conductor sizes, branch circuit protection, and disconnect devices. Failure to do so may result in personal injury and/or equipment damage.

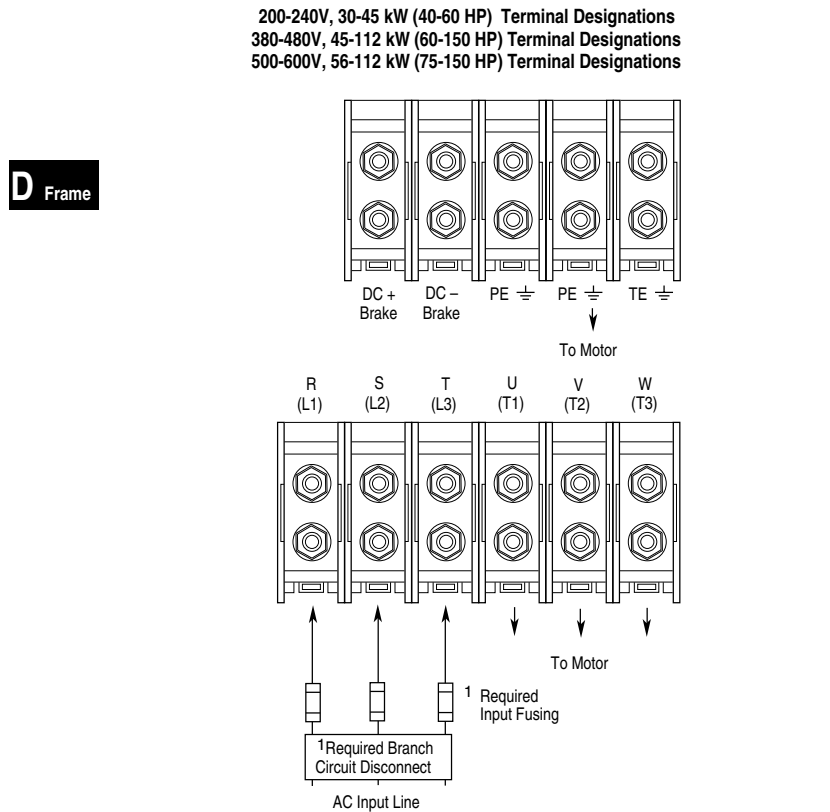
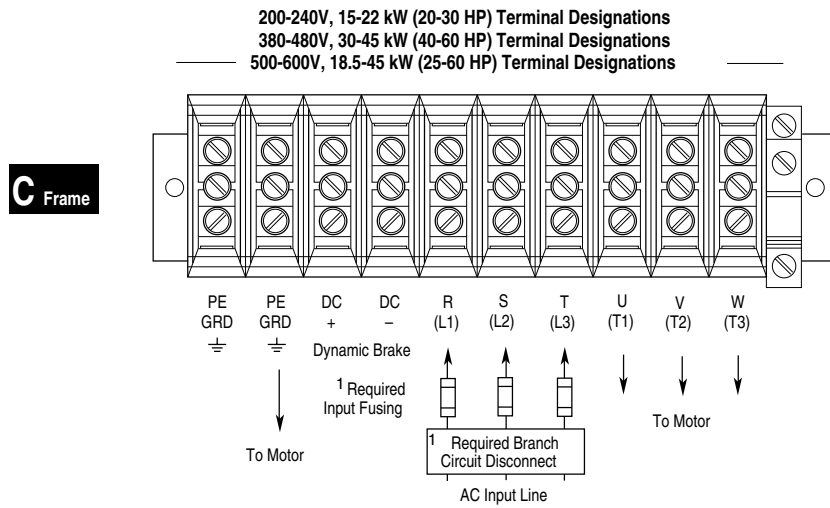
The drive connections for TB1 are shown in Figure 4.2, 4.3, and 4.4.

**Figure 4.2**  
**Drive Connections for Frames B1 and B2**



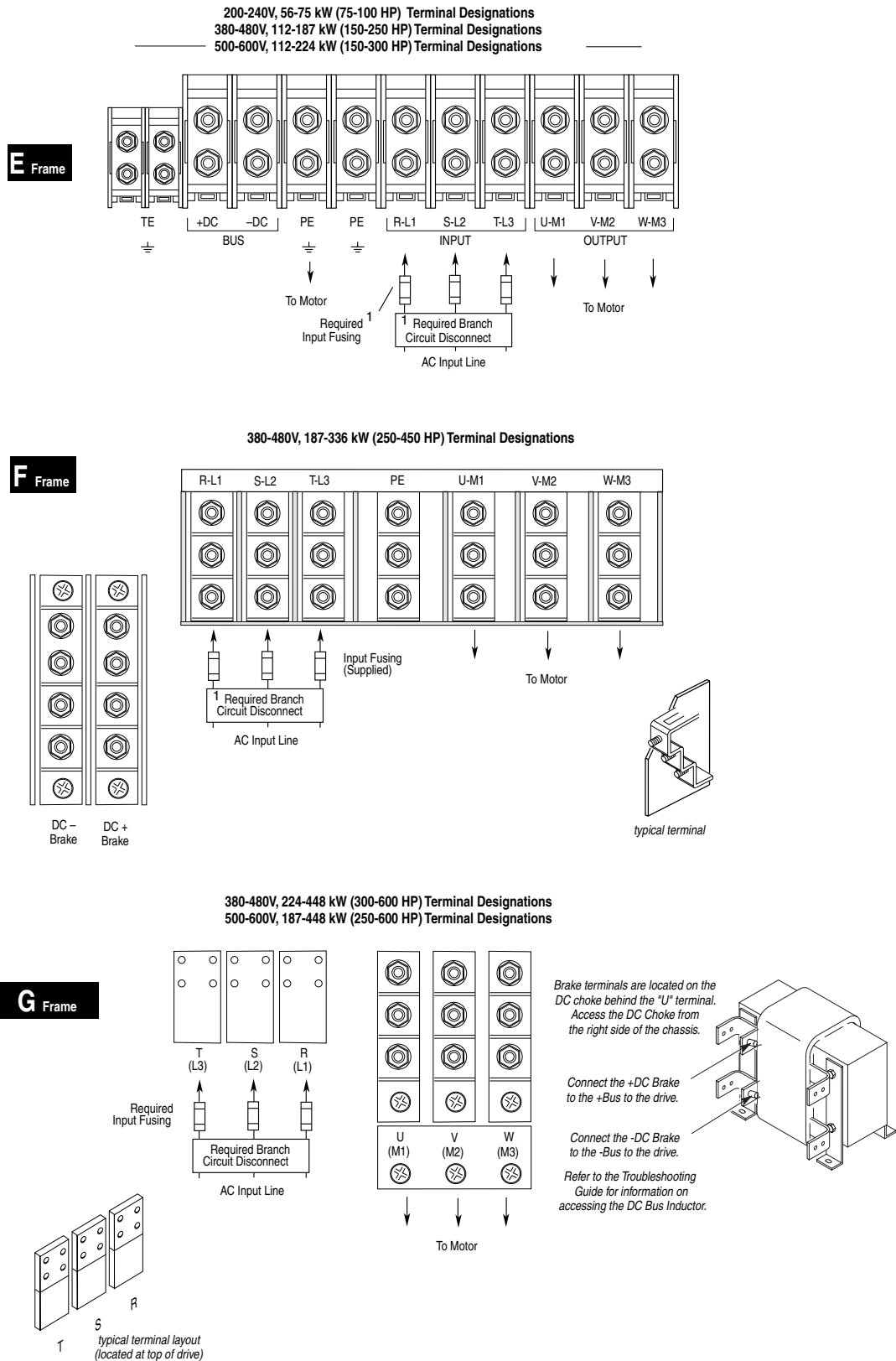
1 User supplied.

**Figure 4.3**  
**Drive Connections for Frames C and D**

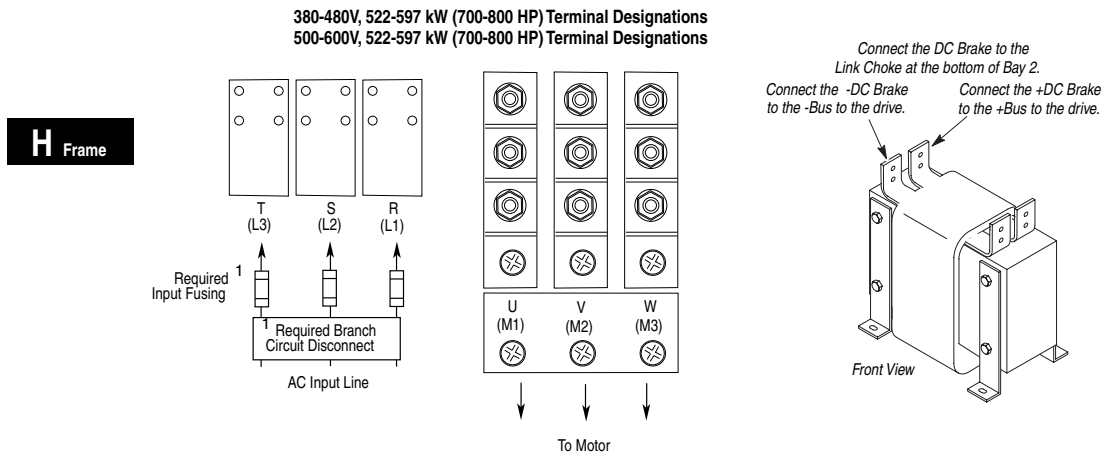


1 User supplied.

**Figure 4.4**  
**Drive Connections for Frames E, F, and G**



**Figure 4.5**  
**Drive Connections for Frame H**



1 User supplied.

## Selecting the Proper Lug Kit for Your System

D, E, F, G, and H frame drives have stud type terminals and/or bus bars/bolts that require standard crimp-type connectors for cable termination. Connectors such as T & B COLOR-KEYED<sup>®</sup> Connectors or equivalent are recommended. Table 4.A shows the lug selection for one possible cable choice. Choose connectors for each installation based on the desired cable sizes, the application requirements, and all applicable national, state, and local codes.



**Table 4.A  
Lug Selection**

Drive Catalog Number	AC Input R, S, T Output U, V, W and PE				DC+ DC- <sup>1</sup>				TE						
	Cable (per Phase)		T&B Part No. <sup>2</sup>		Cable (per Phase)		T&B Part No. <sup>2</sup>		Cable (per Phase)		T&B Part No. <sup>2</sup>				
	Qty.	mm <sup>1</sup> (AWG)	Qty.	Number	Qty.	mm <sup>1</sup> (AWG)	Qty.	Number	Qty.	mm <sup>1</sup> (AWG)	Qty.	Number			
1336E-A040	(1)	53.5 (1/0)	(8)	54153 <sup>3</sup>	(1)	13.3 (6)	(2)	54135 <sup>3</sup>	(1)	13.3 (6)	(1)	54135 <sup>3</sup>			
1336E-A050	(1)	85.0 (3/0)	(8)	54163 <sup>3</sup>	(1)	13.3 (6)	(2)	54135 <sup>3</sup>	(1)	13.3 (6)	(1)	54135 <sup>3</sup>			
1336E-A060	(1)	107.2 (4/0)	(8)	54168 <sup>3</sup>	(1)	13.3 (6)	(2)	54135 <sup>3</sup>	(1)	21.2 (4)	(1)	54139 <sup>3</sup>			
1336E-A075	(2)	53.5 (1/0)	(8)	54109T 54109B	(1)	33.6 (2)	(2)	54109	(1)	21.2 (4)	(1)	54139 <sup>3</sup>			
1336E-A100	(2)	85.0 (3/0)	(8)	54111T 54111B	(1)	42.4 (1)	(2)	54148	(1)	33.6 (2)	(1)	54142 <sup>3</sup>			
1336E-A125	(2)	107.2 (4/0)	(8)	54112T 54112B	(1)	67.4 (2/0)	(2)	54110	(1)	33.6 (2)	(1)	54142 <sup>3</sup>			
1336E-B060	(1)	42.4 (1)	(8)	54147 <sup>3</sup>	(1)	8.4 (8)	(2)	54131 <sup>3</sup>	(1)	13.3 (6)	(1)	54135 <sup>3</sup>			
1336E-B075	(1)	53.5 (1/0)	(8)	54153 <sup>3</sup>	(1)	13.3 (6)	(2)	54135 <sup>3</sup>	(1)	13.3 (6)	(1)	54135 <sup>3</sup>			
1336E-B100	(1)	85.0 (3/0)	(8)	54163 <sup>3</sup>	(1)	13.3 (6)	(2)	54135 <sup>3</sup>	(1)	13.3 (6)	(1)	54135 <sup>3</sup>			
1336E-B125	(1)	107.2 (4/0)	(8)	54168 <sup>3</sup>	(1)	26.7 (3)	(2)	54147 <sup>3</sup>	(1)	21.2 (4)	(1)	54139 <sup>3</sup>			
1336E-BX150	(1)	107.2 (4/0)	(8)	54168 <sup>3</sup>	(1)	26.7 (3)	(2)	54147 <sup>3</sup>	(1)	21.2 (4)	(1)	54139 <sup>3</sup>			
1336E-B150	(2)	53.5 (1/0)	(8)	54109T 54109B	(1)	33.6 (2)	(2)	54110	(1)	21.2 (4)	(1)	54139 <sup>3</sup>			
1336E-B200	(2)	85.0 (3/0)	(8)	54111T 54111B	(1)	42.4 (1)	(2)	54148	(1)	26.7 (3)	(1)	54142 <sup>3</sup>			
1336E-B250	(2)	107.2 (4/0)	(8)	54112T 54112B	(1)	67.4 (2/0)	(2)	54110	(1)	33.6 (2)	(1)	54142 <sup>3</sup>			
1336E-B300	(3)	67.4 (2/0)	(24)	54110	(1)	42.4 (1)	(2)	54148		NA		NA			
1336E-BP300	(3)	67.4 (2/0)	(24)	54110	(1)	42.4 (1)	(2)	54148		NA		NA			
1336E-B350	(3)	85.0 (3/0)	(24)	54111	(1)	42.4 (1)	(2)	54148		NA		NA			
1336E-BP350	(3)	85.0 (3/0)	(24)	54111	(1)	42.4 (1)	(2)	54148		NA		NA			
1336E-B400	(3)	107.2 (4/0)	(24)	54112	(1)	42.4 (1)	(2)	54148		NA		NA			
1336E-BP400	(3)	107.2 (4/0)	(24)	54112	(1)	42.4 (1)	(2)	54148		NA		NA			
1336E-B450	(3)	127.0 (250 MCM)	(24)	54174	(1)	42.4 (1)	(2)	54148		NA		NA			
1336E-BP450	(3)	127.0 (250 MCM)	(24)	54174	(1)	42.4 (1)	(2)	54148		NA		NA			
1336E-B500	(3)	152.0 (300 MCM)	(24)	54179	(1)	53.5 (1/0)	(2)	54109		NA		NA			
1336E-B600	(3)	152.0 (300 MCM)	(24)	54179	(1)	53.5 (1/0)	(2)	54109		NA		NA			
1336E-B700C		—		—	(4)	253.0 (500 MCM)	(8)	54118	(1)	107.2 (4/0)	(1)	54110			
1336E-B800C		—		—	(4)	253.0 (500 MCM)	(8)	54118	(1)	107.2 (4/0)	(1)	54110			
1336E-C075	(1)	33.6 (2)	(8)	54142 <sup>3</sup>	(1)	13.3 (6)	(2)	54135 <sup>3</sup>	(1)	8.4 (8)	(1)	54131 <sup>3</sup>			
1336E-C100	(1)	53.5 (1/0)	(8)	54153 <sup>3</sup>	(1)	13.3 (6)	(2)	54135 <sup>3</sup>	(1)	13.3 (6)	(1)	54135 <sup>3</sup>			
1336E-C125	(1)	67.4 (2/0)	(8)	54158 <sup>3</sup>	(1)	26.7 (3)	(2)	54147 <sup>3</sup>	(1)	13.3 (6)	(1)	54135 <sup>3</sup>			
1336E-C150	(1)	107.2 (4/0)	(8)	54111	(1)	42.4 (1)	(2)	54148	(1)	13.3 (6)	(1)	54135 <sup>3</sup>			
1336E-C200	(2)	67.4 (2/0)	(8)	54110T 54110B	(1)	42.4 (1)	(2)	54148	(1)	26.7 (3)	(1)	54142 <sup>3</sup>			
1336E-C250	(2)	85.0 (3/0)	(8)	54111T 54111B	(1)	67.4 (2/0)	(2)	54110	(1)	26.7 (3)	(1)	54142 <sup>3</sup>			
1336E-CX300	(3)	85.0 (3/0)	(16)	54111	Consult Factory					NA		NA			
1336E-C300	(3)	85.0 (3/0)	(16)	54111						NA		NA			
1336E-C350	(3)	53.5 (1/0)	(24)	54109						NA		NA			
1336E-CP350															
1336E-C400	(3)	67.4 (2/0)	(24)	54110						NA		NA			
1336E-CP400															
1336E-C450	(3)	85.0 (3/0)	(24)	54111						NA		NA			
1336E-C500	(3)	107.2 (4/0)	(24)	54112						NA		NA			
1336E-C600	(3)	127.0 (250 MCM)	(24)	54174						NA		NA			
1336E-C700C		—		—					(3)	253.0 (500 MCM)	(6)	54118	(1)	67.4 (2/0)	(1)
1336E-C800C		—		—	(3)	253.0 (500 MCM)	(6)	54118	(1)	67.4 (2/0)	(1)	54110			

1 Lugs shown for DC+/- are based on dynamic brake sizing of 50% of (motor rating x 1.25). Select proper lugs based on required braking torque. Refer to 1336-5.64 or 1336-5.65 for additional information.

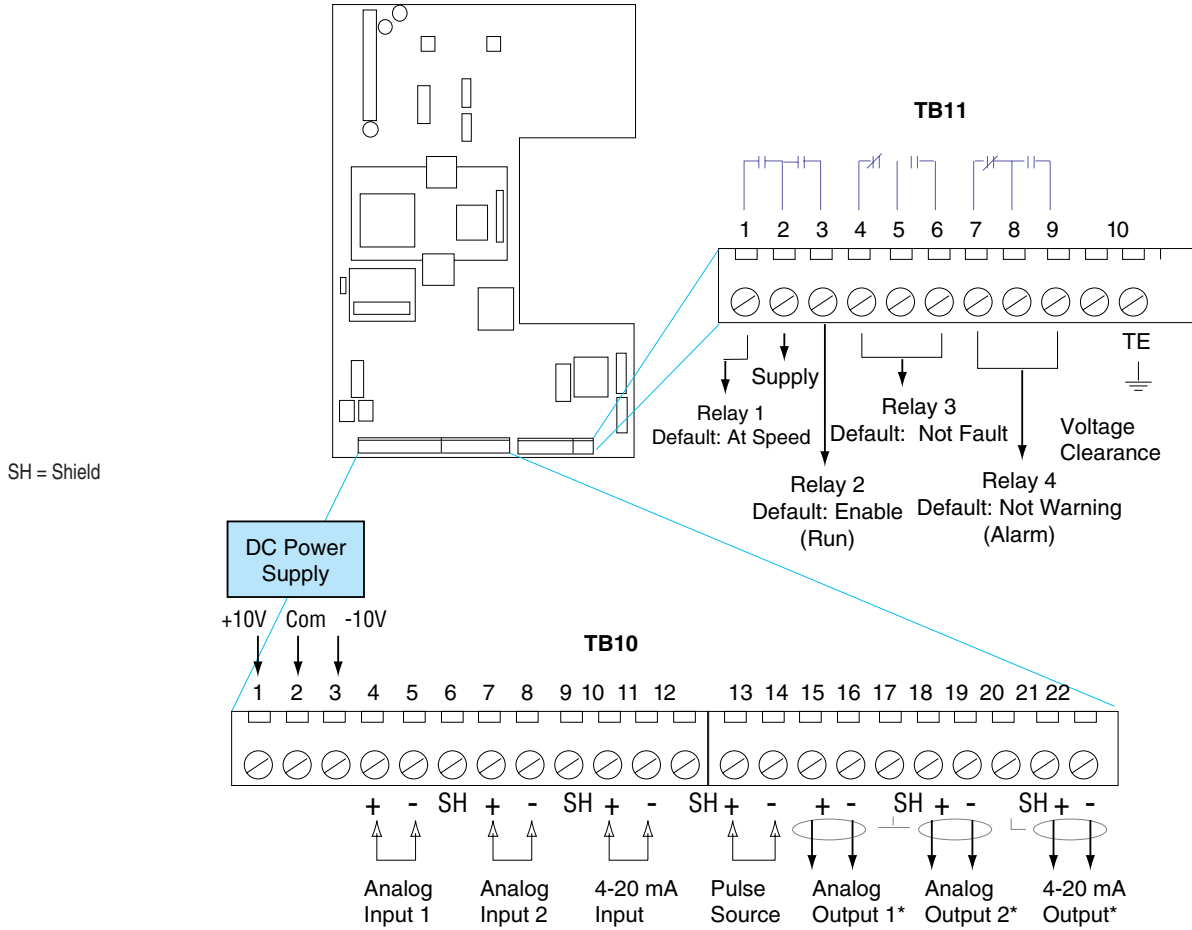
2 T & B COLOR-KEYED<sup>®</sup> Connectors require T & B WT117 or TBM-6 Crimper tool or equivalent. Lugs should be crimped according to manufacturer's tool instructions. If required, Rockwell Automation can supply lug kits for lugs shown above. Kits do not include crimping tools. Consult factory for kit information.

3 5/16" Stud. All other studs are 3/8".

### Hard Wiring Your I/O

You can use terminal blocks TB10 and TB11 for hard wiring your I/O. These terminals are shown in Figure 4.6.

**Figure 4.6**  
**Reference Signal Connections**



NOTE: Analog I/O is differential, non-isolated I/O. A negative (-) does not indicate common.

The terminal blocks provide the following:

This terminal block:	Provides these terminal numbers:	Which provide access to this signal:
TB10	6, 9, 12, 17, 20	Shield ground
	1, 2, 3	DC power supply $\pm 10V$ DC 50 mA per voltage
	4, 5, 7, 8	0 to $\pm 10V$ DC Input      Input impedance = 20K Ohms
	10, 11	4 – 20 mA input      Input impedance = 130 Ohms
	13, 14	Pulse input for frequency reference +5V DC — Jumper J4 Set to 1 – 2 +12V DC — Jumper J4 Set to 2 – 3 Scale Factor (Pulse PPR) must be set 10mA minimum
	15, 16, 18, 19	0 to $\pm 10V$ DC output      Output impedance = 100 Ohms, 10mA maximum
	21, 22	4 – 20 mA DC output      Output impedance = 20 Ohms
TB11	10	Logic Earth Ground, Shield
	1, 2, 3, 4, 5, 6, 7, 8, 9	Programmable contacts Resistive rating = 115VAC/30VDC, 5.0A Inductive rating = 115VAC/30VDC, 2.0A

The voltage clearance provides physical space between the logic earth ground and other signals on the terminal block.

## Selecting/Verifying Fan Voltage

1336 IMPACT drives, 45 kW (60 hp) to 448 kW (600 hp) that have cooling fans use a transformer to match the input line voltage to the proper fan voltage. If you are using an input voltage other than the standard 240, 480, or 600V AC, you may need to change the transformer tap.

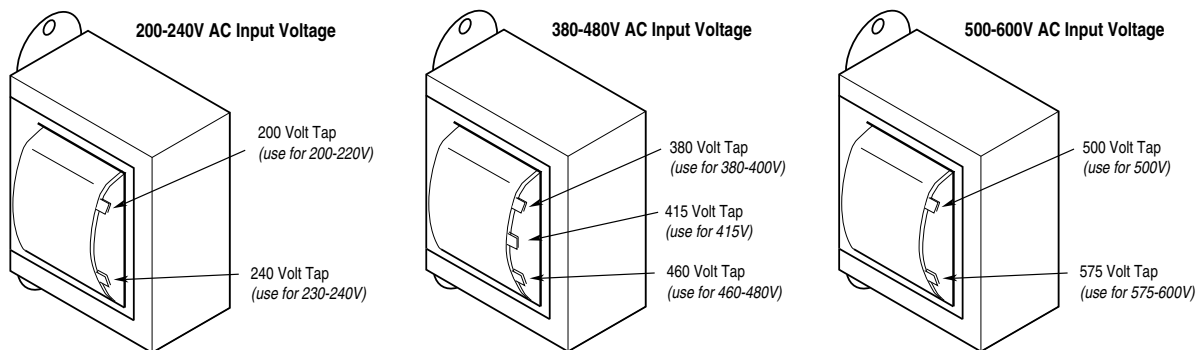
To change a transformer tap, follow these instructions:



**ATTENTION:** To avoid a shock hazard, assure that all power to the drive has been removed before proceeding.

1. Ensure that all power has been removed to the drive.
2. Locate the transformer in the lower left corner of the drive chassis. Note lead placement (tap being used).
3. Determine the correct tap from Figure 4.7 and verify.
4. If the present tap is incorrect, remove the insulating sleeve from the correct tap.
5. Remove the wire lead presently connected.
6. Place the wire lead on the selected tap.
7. Replace the insulating sleeve on the unused tap.

**Figure 4.7**  
**Fan Tap Locations**



### Input Fusing Requirements

The following are the input fusing requirements for frames B, C, D, E, F, G, and H.

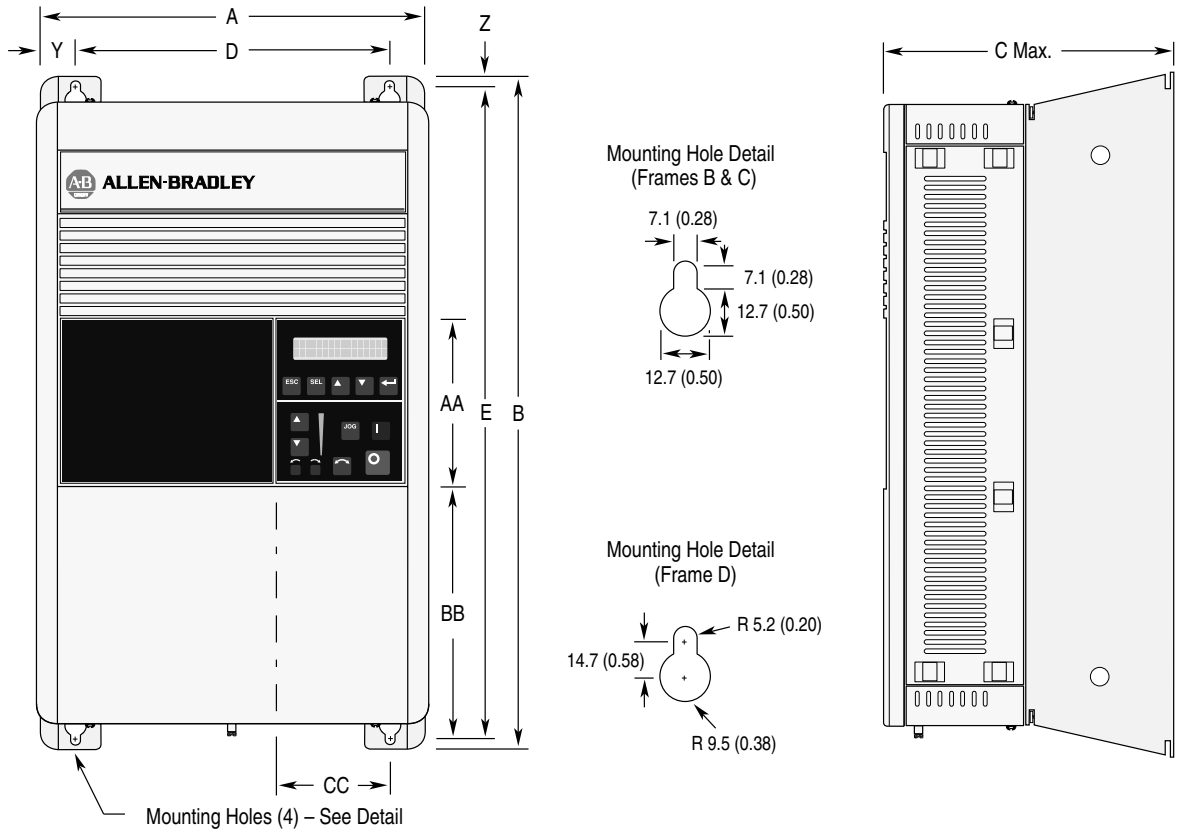
Maximum Recommended AC Input Line Fuse Ratings (fuses are user supplied)						
European Installations	North American Installations	Drive Catalog Number	kW (HP) Rating	200 – 240V Rating	380 – 480V Rating	500 – 600V Rating
<p>The recommended fuse is Class gG, general industrial applications and motor circuit protection.</p> <p>BS88 (British Standard) Parts 1 &amp; 2*, EN60269-1, Parts 1 &amp; 2, type gG or equivalent should be used for these drives. Fuses that meet BS88 Parts 1 &amp; 2 are acceptable for Frames A – F.</p> <p>* Typical designations include, but may not be limited to the following: Parts 1 &amp; 2: AC, AD, BC, BD, CD, DD, ED, EFS, EF, FF, FG, GF, GG, GH.</p>	<p>UL requirements specify that UL Class CC, T, or J<sup>1</sup> fuses must be used for all drives in this section*.</p> <p>* Typical designations include: Type CC: KTK, FNQ-R Type J: JKS, LPJ Type T: JJS, JJN</p> <p>UL requirements specify that UL Class CC, T, or J<sup>1</sup> fuses must be used for all drives in this section*.</p> <p>* Typical designations include: Type CC: KTK, FNQ-R Type J: JKS, LPJ Type T: JJS, JJN</p>	1336E-__ 007	5.5 (7.5)	40A	20A	15A
		1336E-__ 010	7.5 (10)	50A	30A	20A
		1336E-__ 015	11 (15)	70A	35A	25A
		1336E-__ 020	15 (20)	100A	45A	35A
		1336E-__ 025	18.5 (25)	100A	60A	40A
		1336E-__ 030	22 (30)	125A	70A	50A
		1336E-__ X040	30 (40)	150A	80A	60A
		1336E-__ 040	30 (40)	150A	80A	60A
		1336E-__ 050	37 (50)	200A	100A	80A
		1336E-__ X060	45 (60)	—	100A	—
		1336E-__ 060	45 (60)	250A	125A	90A
		1336E-__ 075	56 (75)	300A	150A	110A
		1336E-__ 100	75 (100)	400A	200A	150A
		1336E-__ 125	93 (125)	450A	250A	175A
		1336E-__ X150	112 (150)	—	250A	—
		1336E-__ 150	112 (150)	—	300A	225A
		1336E-__ 200	149 (200)	—	400A	350A
		1336E-__ 250	187 (250)	—	450A	400A
		1336E-__ X300	224 (300)	—	—	400A
		<p>The recommended fuse is Class gG, general industrial applications and motor circuit protection.</p> <p>BS88 (British Standard) Part 4, EN60269-1, Part 4*, type gG semiconductor fuses or equivalent should be used for these drives. G Frame drives require semiconductor fuses and should be fused with Part 4 fuses.</p> <p>* Typical designations include, but may not be limited to the following: Part 4: CT, ET, FE, EET, FEE, RFEE, FM, FMM.</p>	<p>Bussmann FWP/Gould Shawmut A-70Q or QS semiconductor type fuses must be used for all drives in this section.</p>	1336E-__ 300	224 (300)	—
1336E-__ P300 <sup>2</sup>	224 (300)			—	500A <sup>2</sup>	—
1336E-__ 350	224 (300)			—	600A	450A
1336E-__ P350 <sup>2</sup>	261 (350)			—	600A <sup>2</sup>	— <sup>2</sup>
1336E-__ 400	298 (400)			—	600A	500A
1336E-__ P400 <sup>2</sup>	298 (400)			—	600A <sup>2</sup>	— <sup>2</sup>
1336E-__ 450	336 (450)			—	800A	600A
1336E-__ P450 <sup>2</sup>	336 (450)			—	700A <sup>2</sup>	— <sup>2</sup>
1336E-__ 500	373 (500)			—	800A	800A
1336E-__ 600	448 (600)			—	900A	800A
1336E-__ 650	485 (650)			—	—	800A
1336E-__ 700C <sup>2</sup>	522 (700)			—	600A <sup>3</sup>	700A <sup>3</sup>
1336E-__ 800C <sup>2</sup>	597 (800)			—	700A <sup>3</sup>	700A <sup>3</sup>

1 Both fast acting and slow blow are acceptable.  
 2 Fuses are supplied with F and H Frame drives.  
 3 Two fuses in parallel are required.

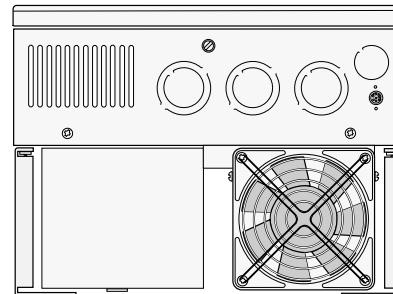
**Dimensions**

The following are the dimensions for the B, C, D, E, F, G, and H frames.

**Dimensions for Frames B, C, and D**



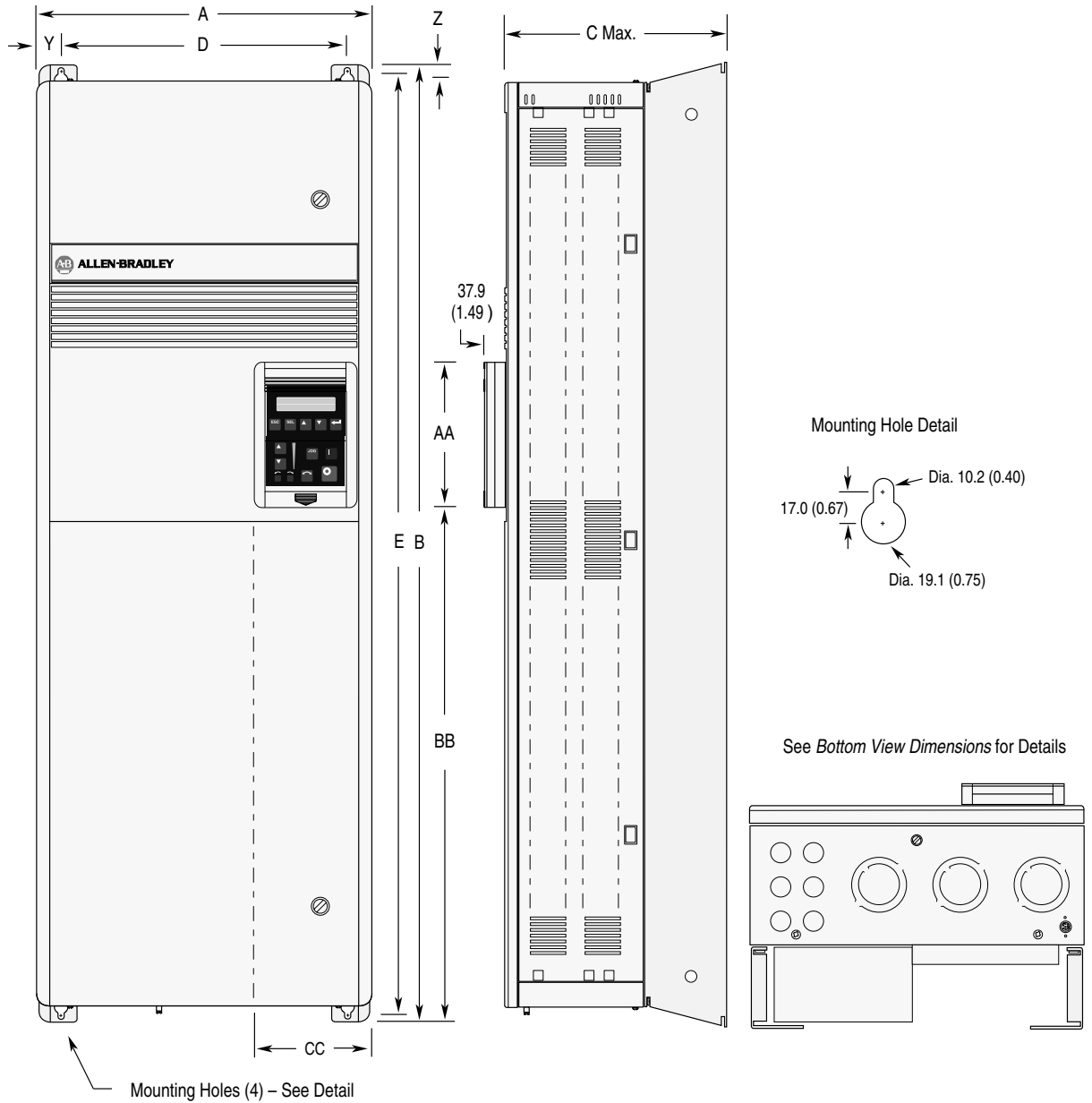
Bottom View Will Vary with HP – See *Bottom View Dimensions*



*All Dimensions in Millimeters and (Inches).  
All Weights in Kilograms and (Pounds).*

Frame Reference	A	B	C Max.	D	E	Y	Z	AA	BB	CC	Shipping Weight
B	276.4 (10.88)	476.3 (18.75)	225.0 (8.86)	212.6 (8.37)	461.0 (18.15)	32.00 (1.26)	7.6 (0.30)	131.1 (5.16)	18.08 (7.12)	71.9 (2.83)	22.7 kg (50 lbs)
C	301.8 (11.88)	701.0 (27.60)	225.0 (8.86)	238.0 (9.37)	685.8 (27.00)	32.00 (1.26)	7.6 (0.30)	131.1 (5.16)	374.7 (14.75)	71.9 (2.83)	38.6 kg (85 lbs)
D	381.5 (15.02)	1240.0 (48.82)	270.8 (10.66)	325.9 (12.83)	1216.2 (47.88)	27.94 (1.10)	11.94 (0.47)	131.1 (5.16)	688.6 (27.11)	83.6 (3.29)	108.9 kg (240 lbs)

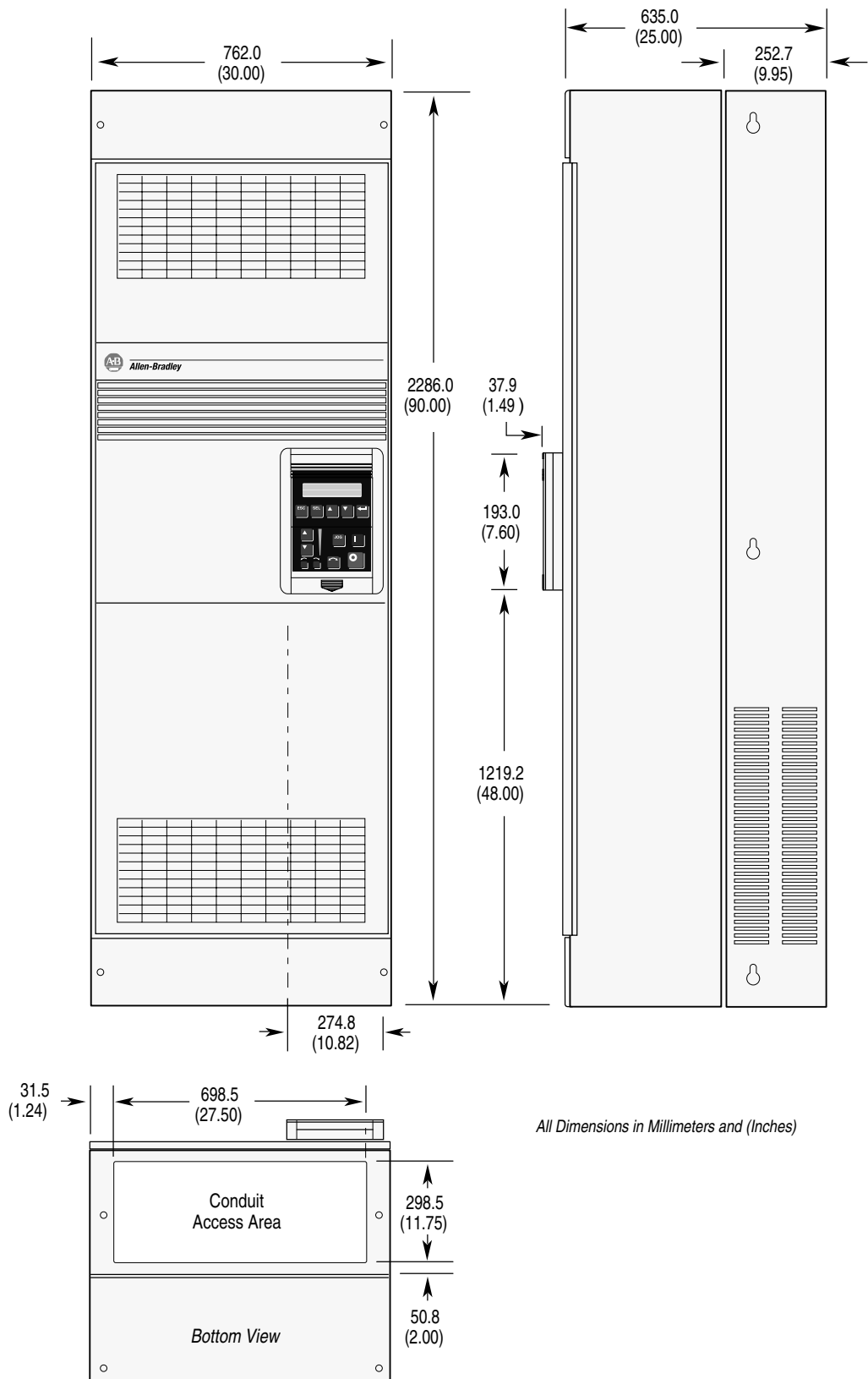
**Dimensions for Frame E**



*All Dimensions in Millimeters and (Inches).  
All Weights in Kilograms and (Pounds).*

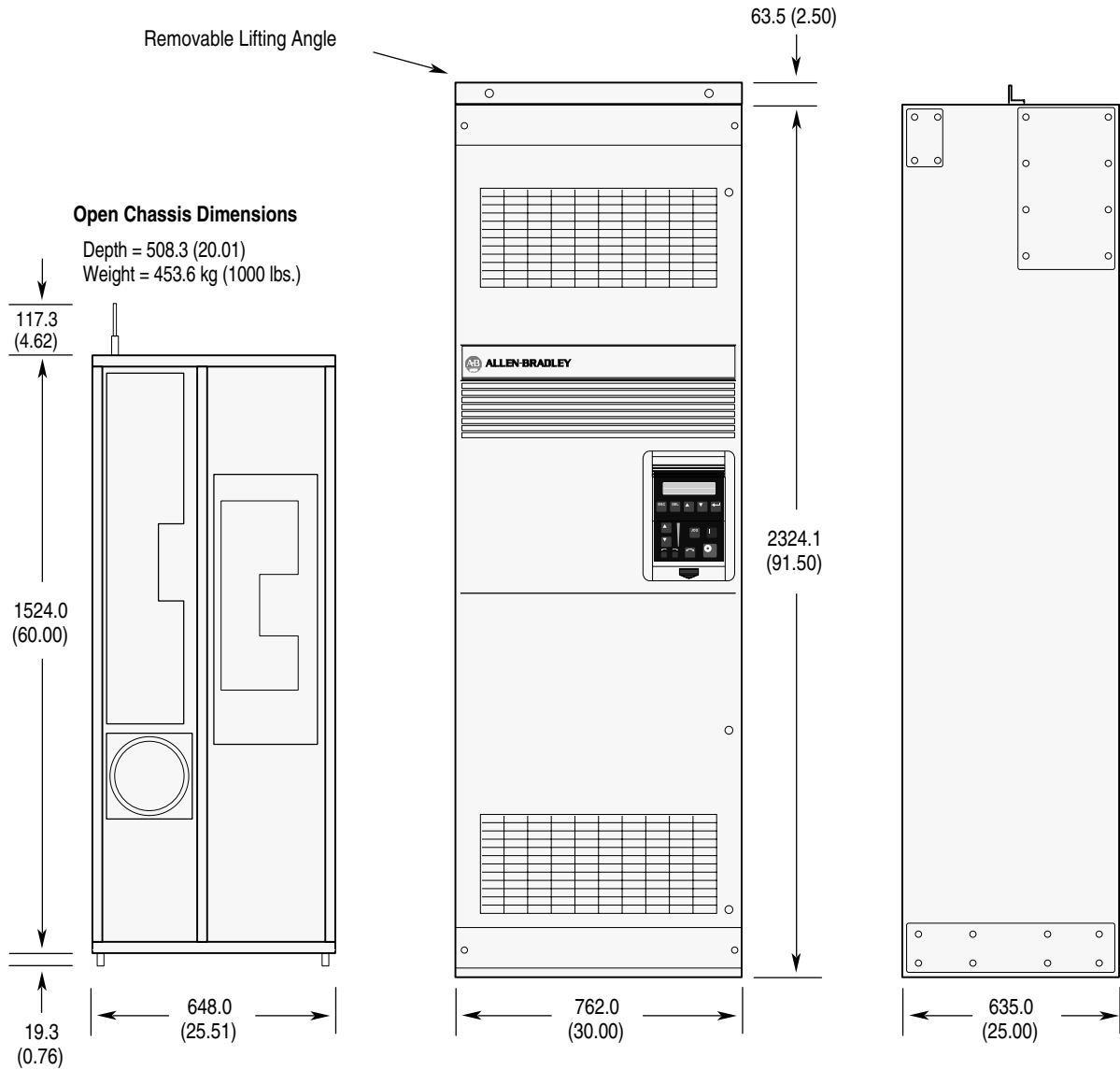
Frame Reference	A	B	C Max.	D	E	Y	Z	AA	BB	CC	Shipping Weight
E — Enclosed	511.0 (20.12)	1498.6 (59.00)	424.4 (16.71)	477.5 (18.80)	1447.8 (57.00)	16.8 (0.66)	40.1 (1.61)	195.0 (7.68)	901.4 (35.49)	151.9 (5.98)	186 kg (410 lbs)
E — Open	511.0 (20.12)	1498.6 (59.00)	372.6 (14.67)	477.5 (18.80)	1447.8 (57.00)	16.8 (0.66)	40.1 (1.61)	138.4 (5.45)	680.0 (26.77)	126.3 (4.97)	163 kg (360 lbs)

### Dimensions for Frame F

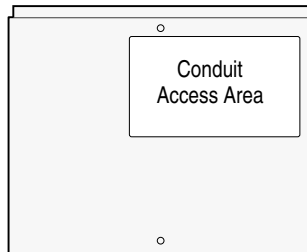




### Dimensions for Frame G



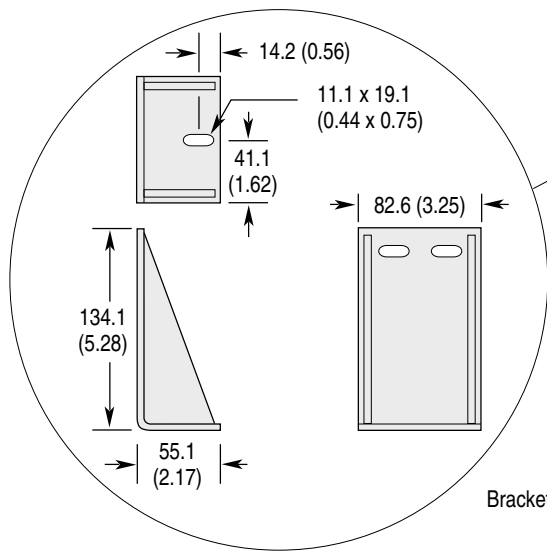
**Important:** Two (2) 725 CFM fans are required if an open type drive is mounted in a user supplied enclosure.



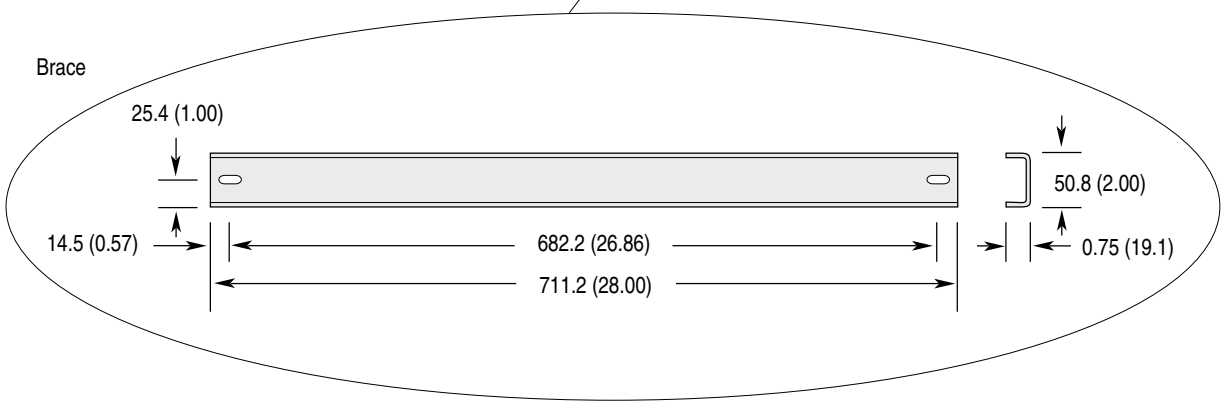
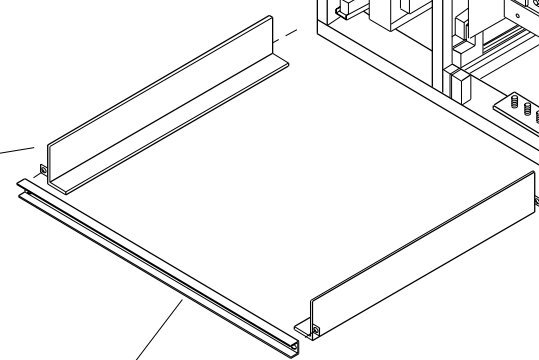
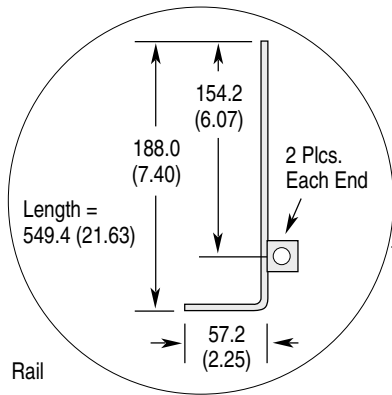
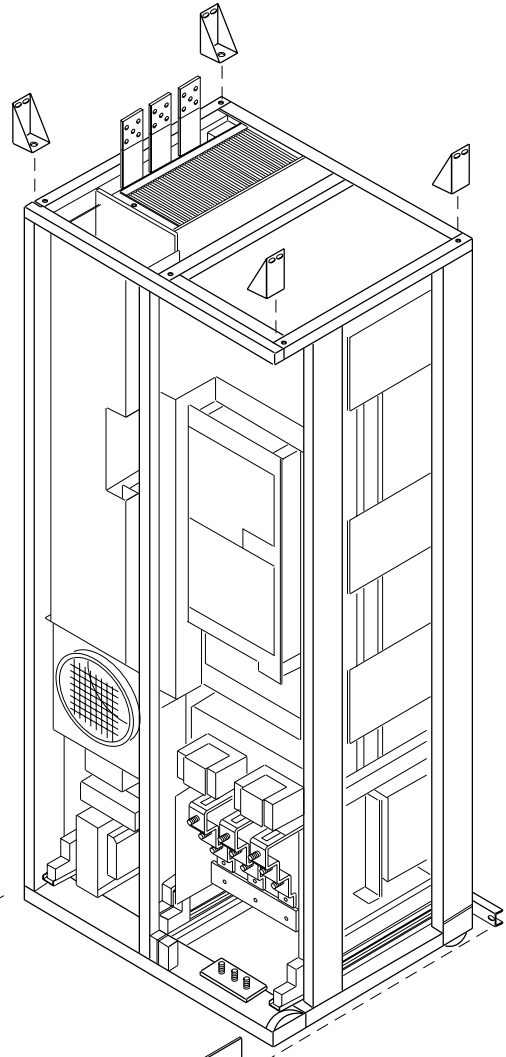
All Dimensions in Millimeters and (Inches)

See *Bottom View Dimensions* for Details

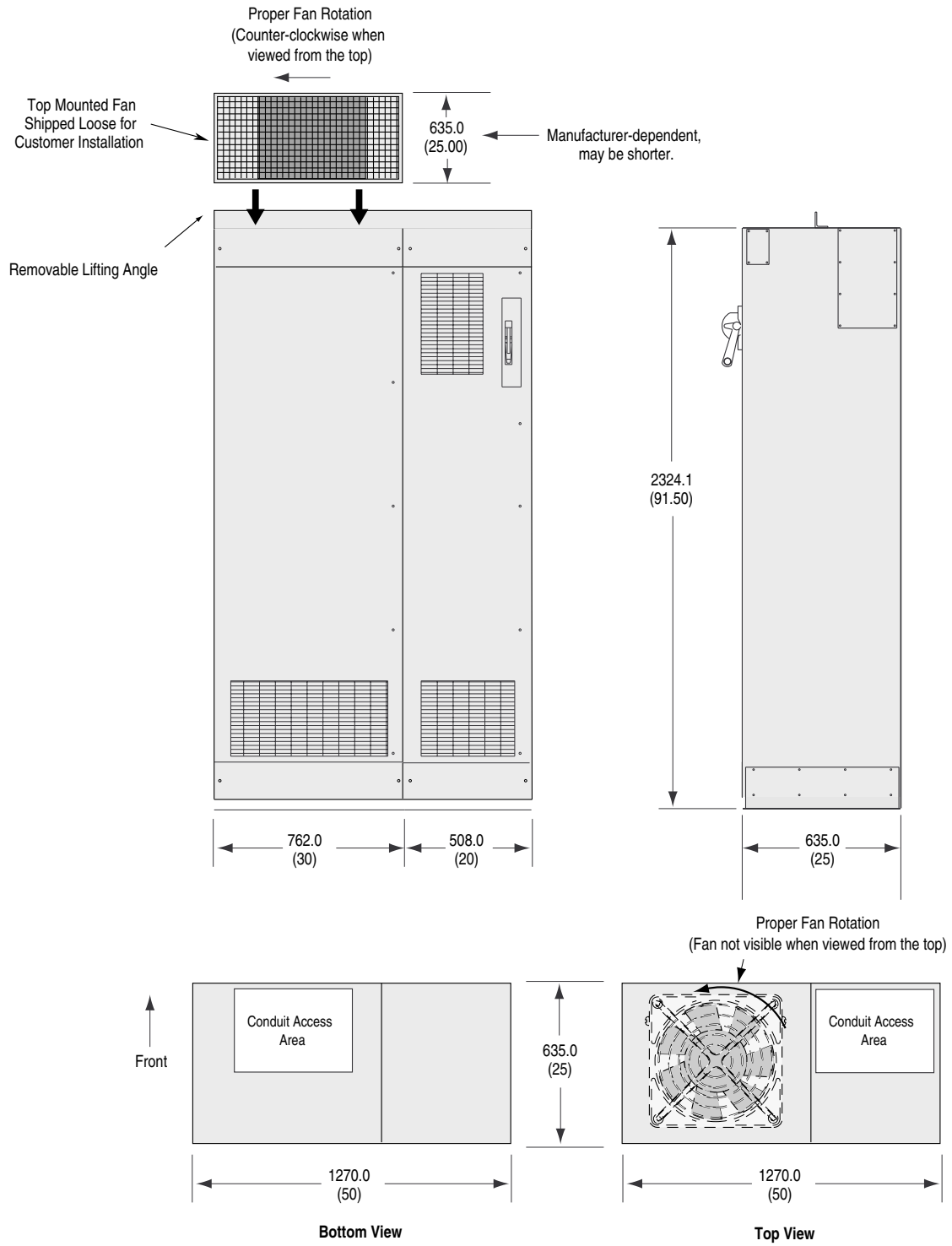
### Typical G Frame Mounting in User Supplied Enclosure



**Important:** This information represents the method used to factory mount an open type Frame G in an enclosure specifically designed by Allen-Bradley. Illustrations are only intended to identify structural mounting points and hardware shapes. You must design and fabricate steel components based on the actual mounting configuration, calculated loads and enclosure specifications. Minimum thickness of all parts = 4.6 (0.18).

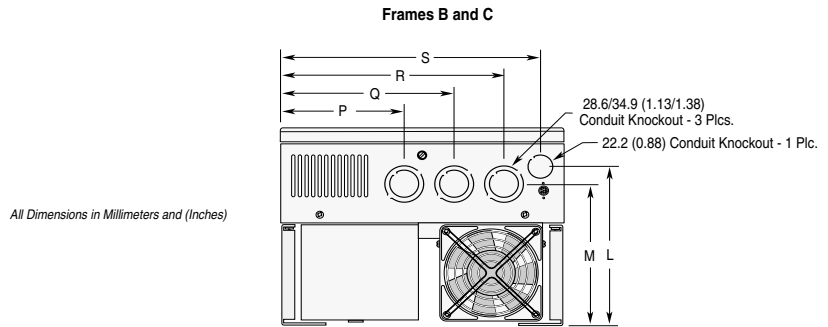


### Dimensions for Frame H

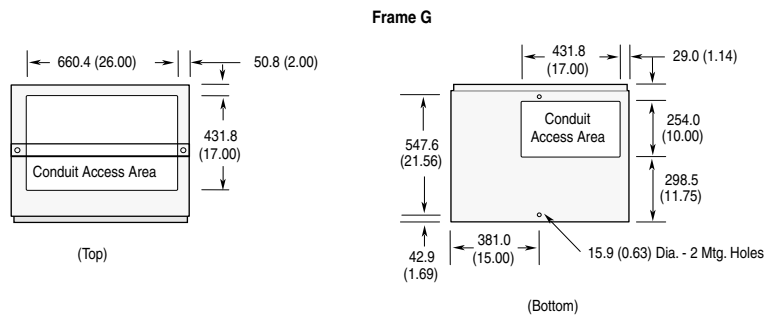
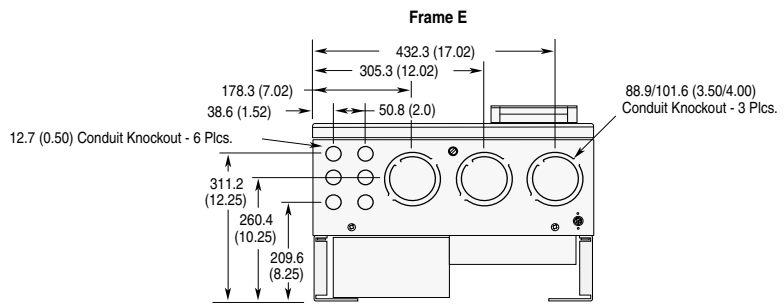
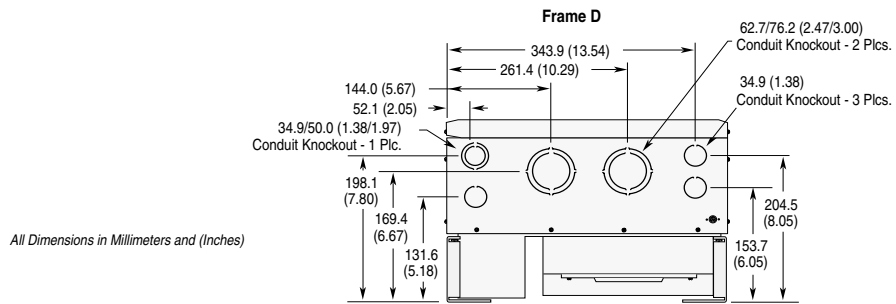


All Dimensions in Millimeters and (Inches)

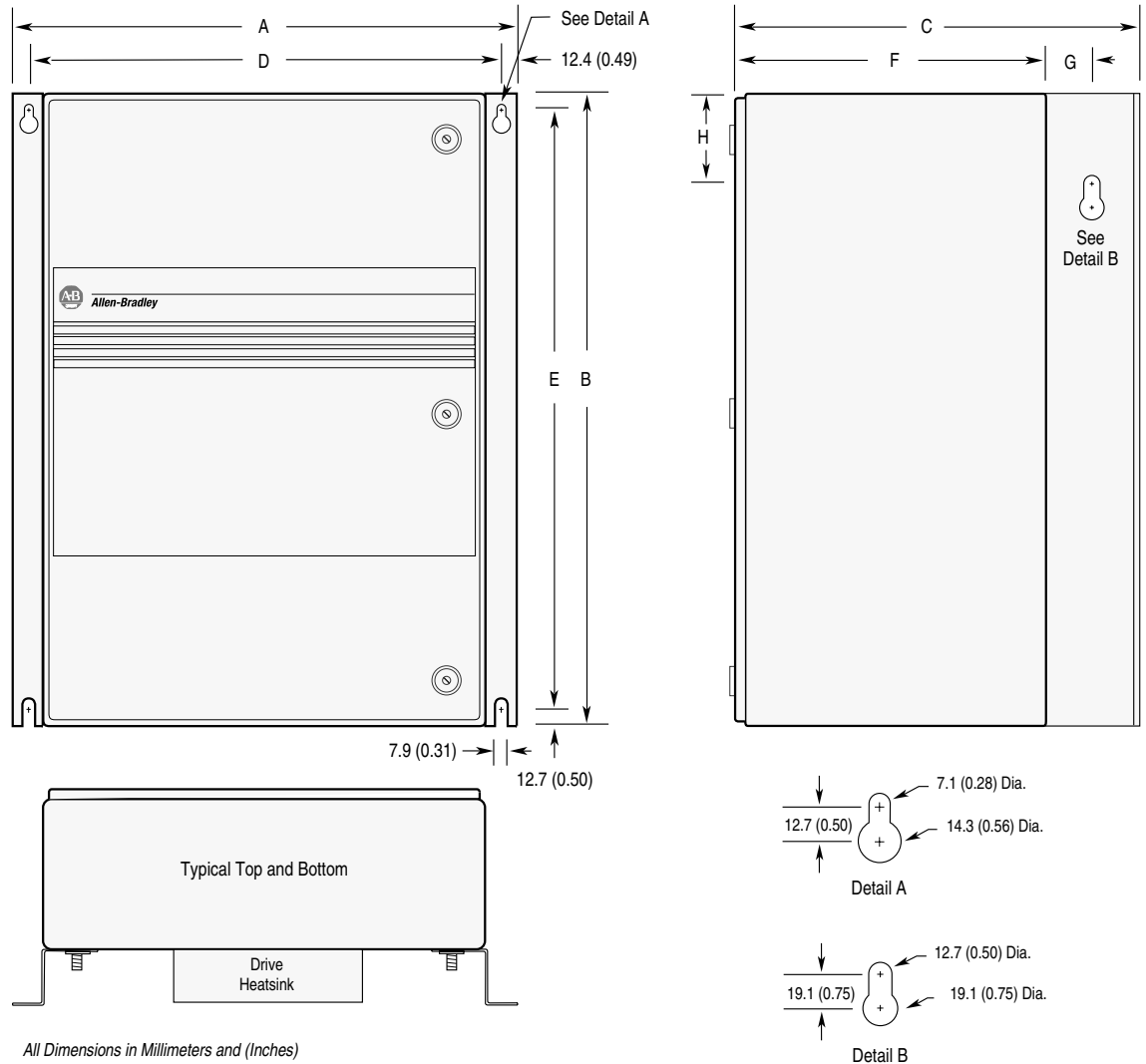
### Bottom Dimensions for Frames B – G



Frame Reference	L	M	P	Q	R	S
B	181.6 (7.15)	167.1 (6.58)	112.8 (4.44)	163.6 (6.44)	214.4 (8.44)	249.9 (9.84)
C	181.6 (7.15)	167.1 (6.58)	119.1 (4.69)	182.6 (7.19)	227.1 (8.94)	275.3 (10.84)



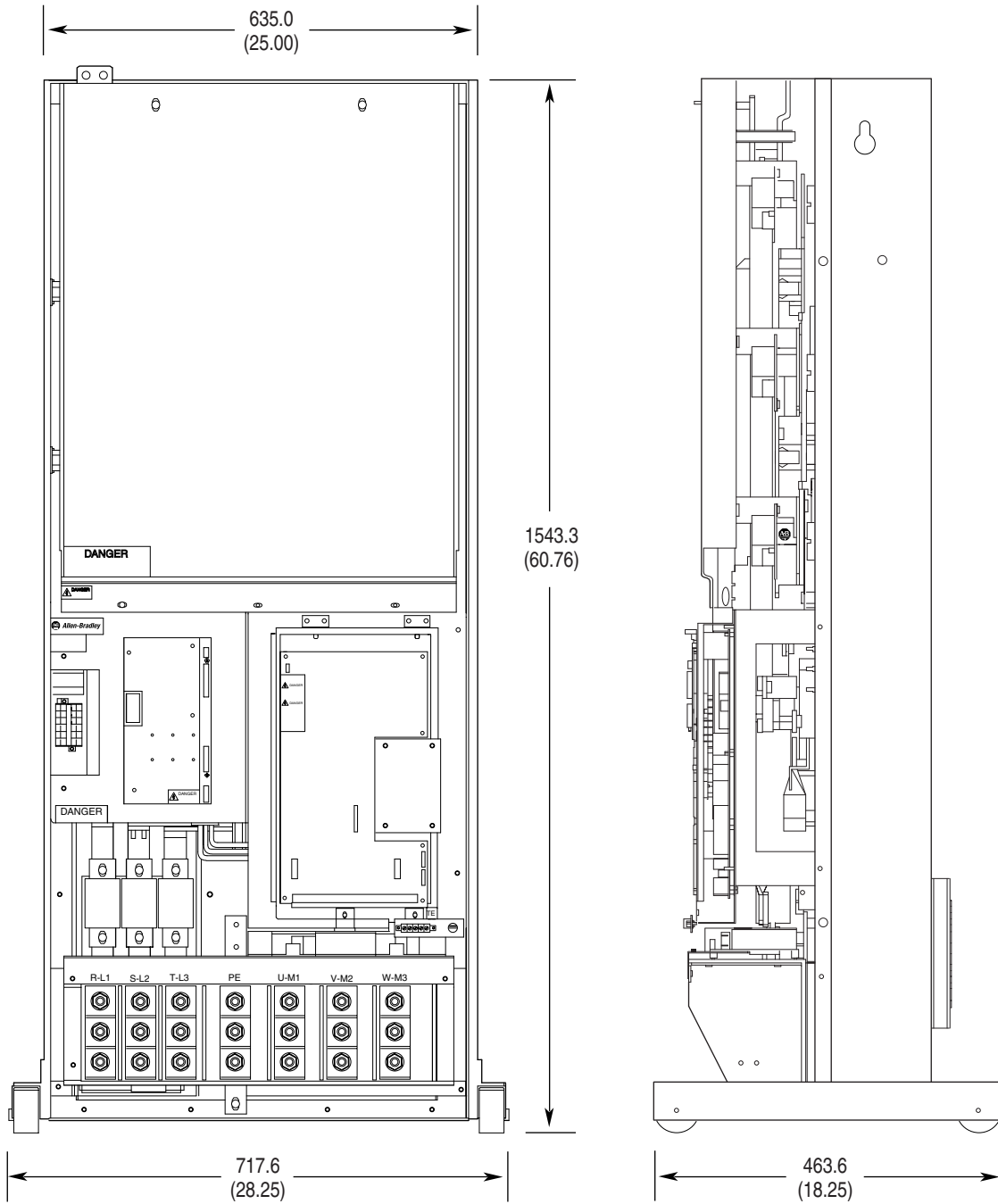
The following are the dimensions for the IP65/54 (NEMA 4/12) enclosures.



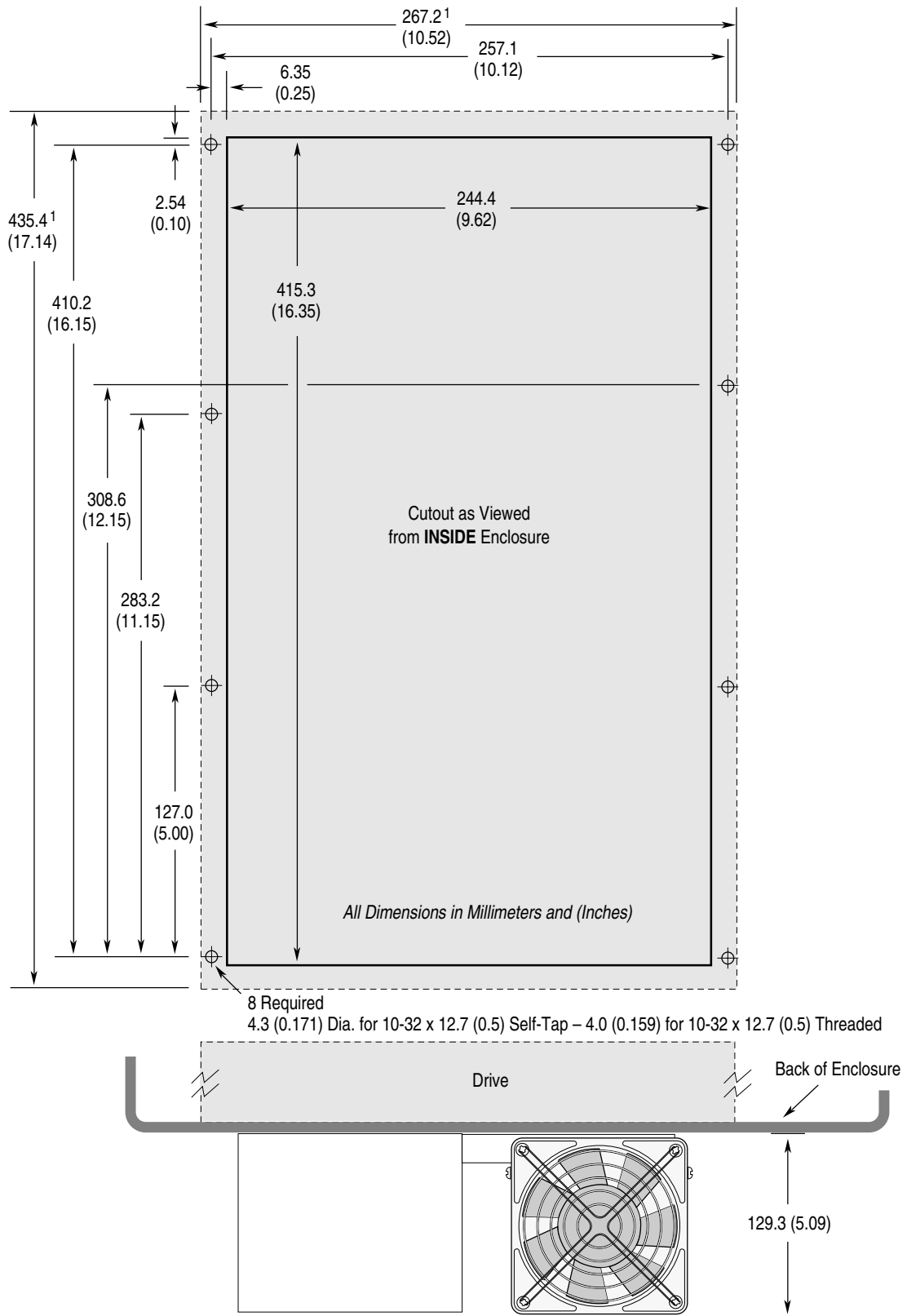
Frame Reference	A	B	C	D	E	F	G	H	Approx. Ship Weight
B1	655.0 (25.79)	650.0 (25.59)	425.0 (16.74)	629.9 (24.80)	625.1 (24.61)	293.0 (11.54)	63.5 (2.50)	76.2 (3.00)	44.7 kg (98.5 lbs)
B2	655.0 (25.79)	900.0 (35.43)	425.0 (16.74)	629.9 (24.80)	875.0 (34.45)	293.0 (11.54)	63.5 (2.50)	76.2 (3.00)	56.5 kg (124.5 lbs)
C	655.0 (25.79)	1200.0 (47.24)	425.0 (16.74)	629.9 (24.80)	1174.5 (46.22)	293.0 (11.54)	63.5 (2.50)	76.2 (3.00)	80.7 kg (178.0 lbs)

### Open Dimensions - Frame F "Roll-In Chassis"

All Dimensions in Millimeters and (Inches)

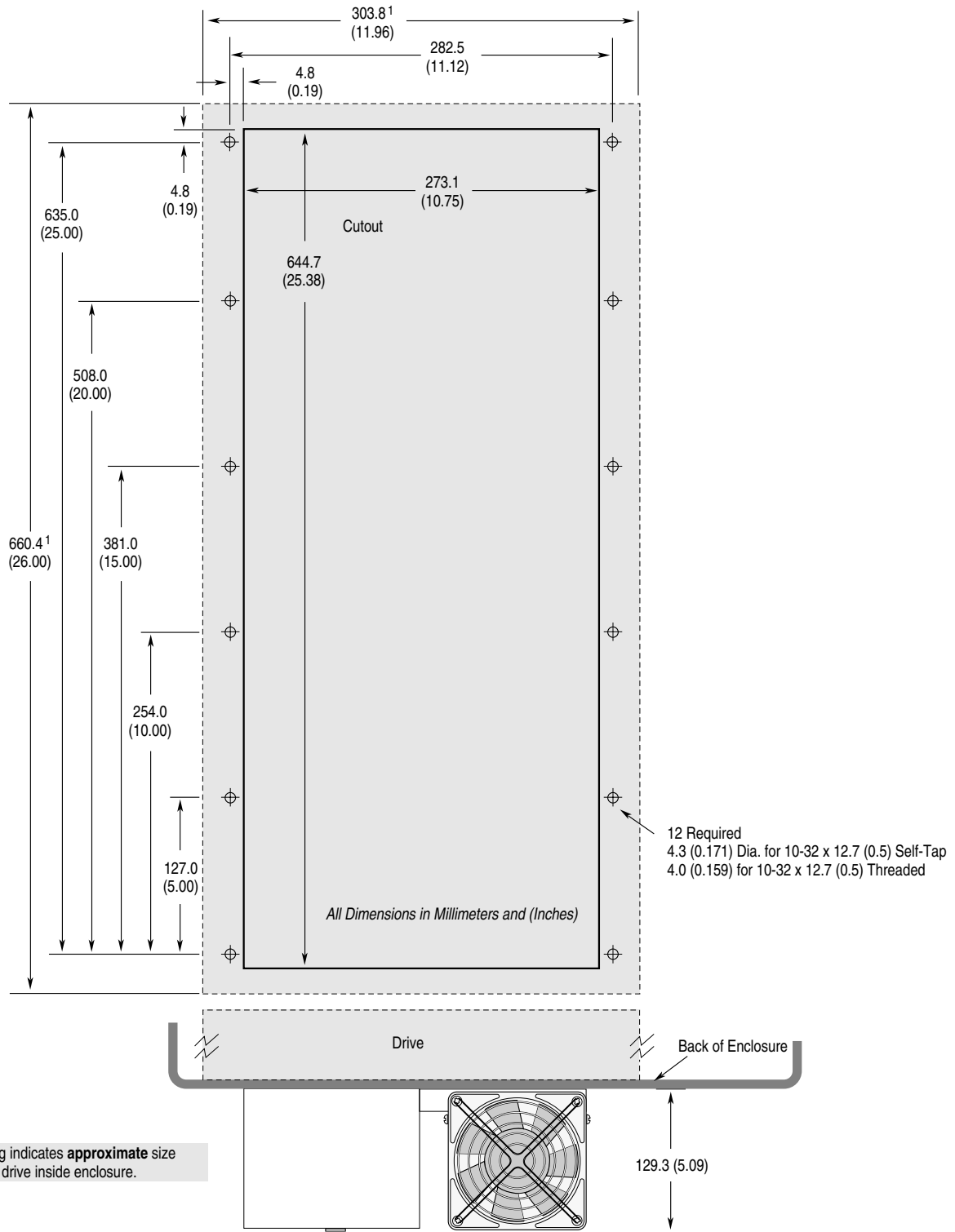


Heat Sink Through-the-Back Mounting - Frame B1/B2



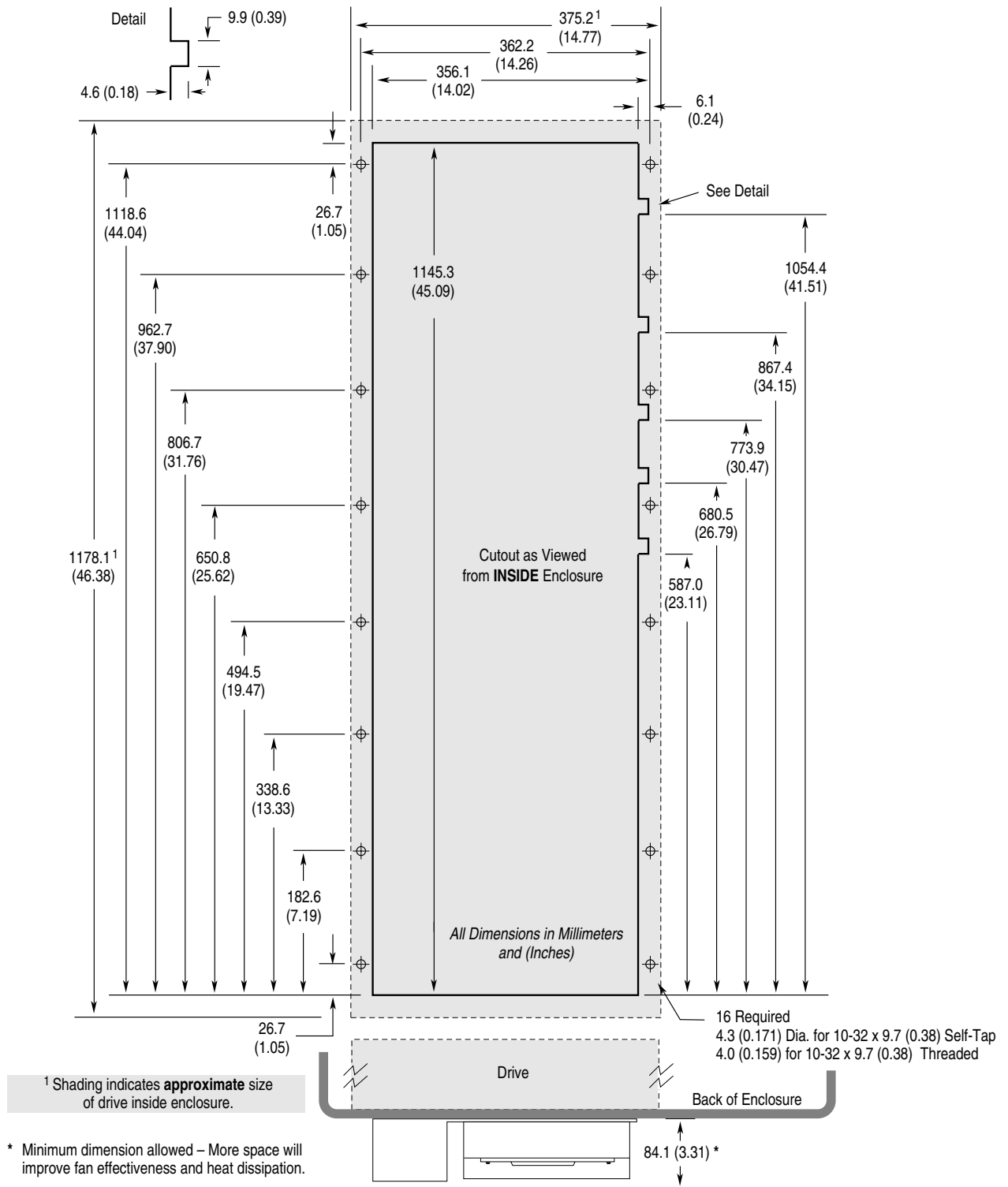
<sup>1</sup> Shading indicates **approximate** size of drive inside enclosure.

Heat Sink Through-the-Back Mounting - Frame C

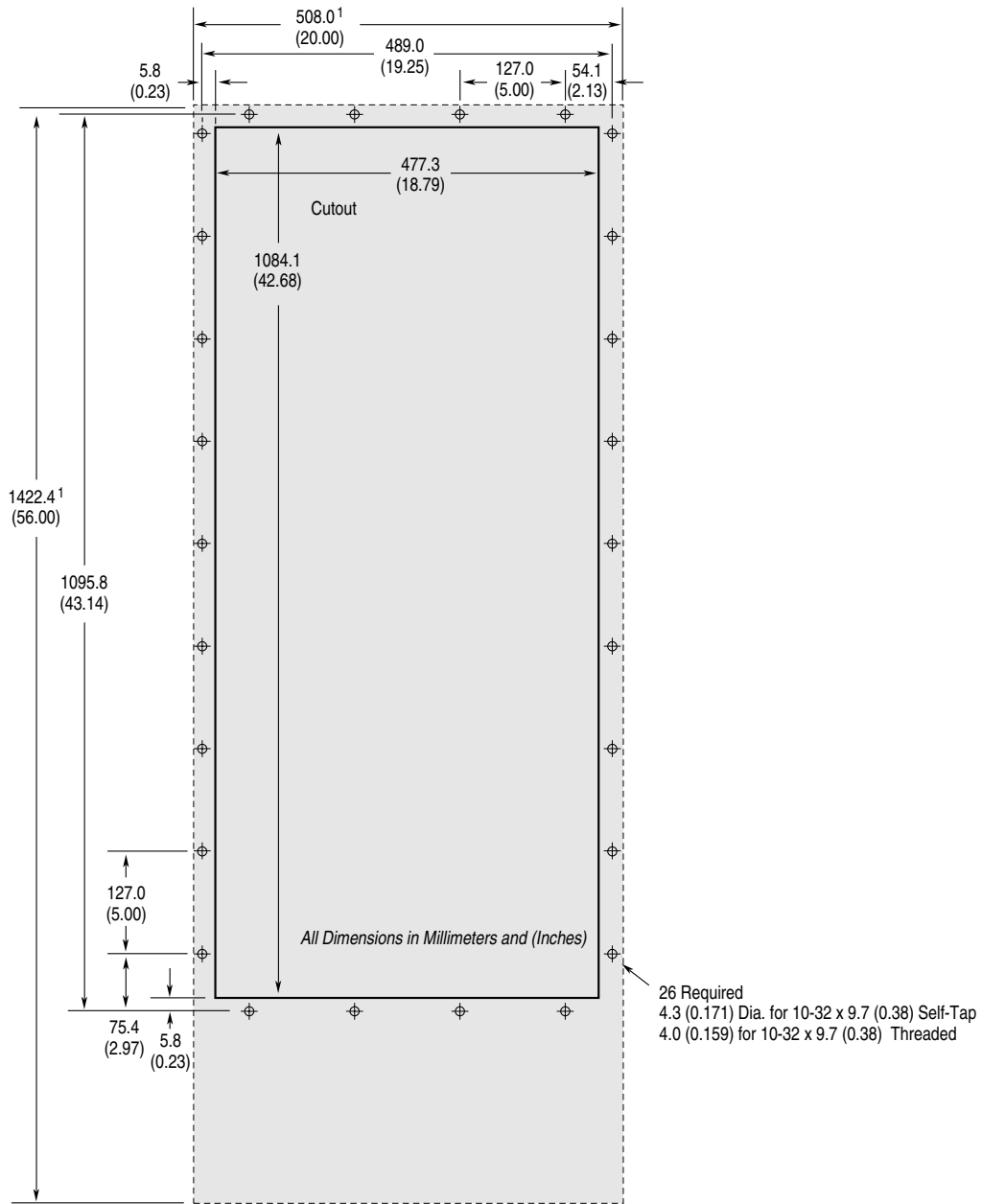




Heat Sink Through-the-Back Mounting - Frame D

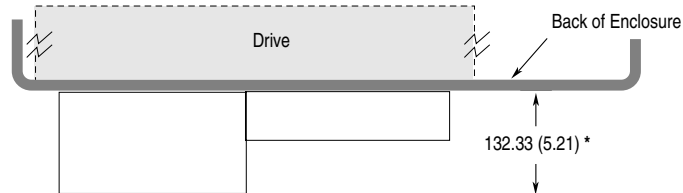


Heat Sink Through-the-Back Mounting - Frame E



<sup>1</sup> Shading indicates **approximate** size of drive inside enclosure.

\* Minimum dimension allowed – More space will improve fan effectiveness and heat dissipation.



## Using the L Option

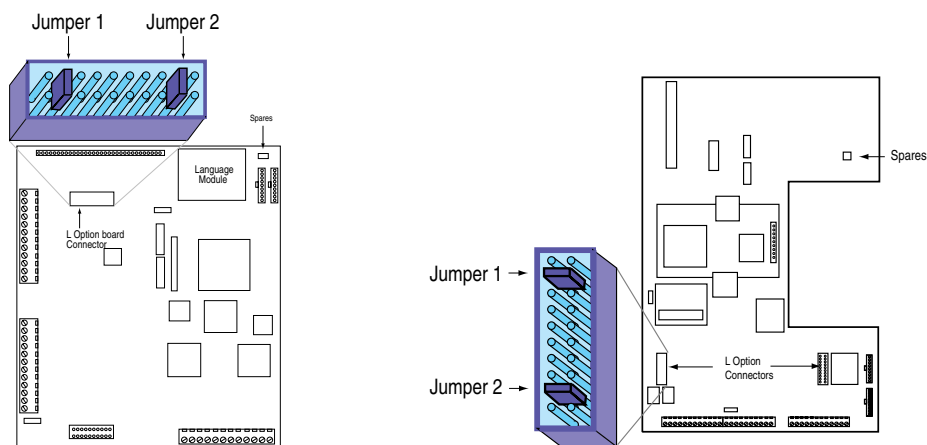
### Chapter Objectives

Chapter 5 provides information to help you set up and use the L Option.

This topic:	Starts on page:
A description of the L Option	5-2
A list of the available functions	5-3
Setting up the L Option board	5-4
Using an encoder with the L Option board	5-11
Individual board requirements	5-11

**Important:** If you are using an L Option board, you must wire the L Option board before you start your drive.

If you do not have an L Option board installed, verify that two jumpers are installed at connector J5 (for frames A1 – A4) or J2 (for frames B – H), one at pins 3 and 4 and the other at pins 17 and 18. You can skip the remainder of this chapter.



- ▶ Spare jumpers are located at J12 and J13 for Frames A1 – A4 and J17 and J18 for Frames B – H.



**ATTENTION:** If you are using an L8E or L9E for the encoder but do not want to use the L Option inputs, you need to place jumpers on J5 (stop) and J6 (enable) on the L Option board. However, these jumpers must **not** be present if you use the L Option inputs as the jumpers cause the stop and enable functions to be permanently enabled.

## What is the L Option?

The L Option is a plug-in option card that provides control inputs to the drive. The six versions of the L Option are:

This option:	Is a:	Can you attach an encoder?	This option is compatible with these Allen-Bradley PLC modules:
L4 <sup>1</sup>	Contact closure interface	No	1771-OYL, 1171-OZL
L7E <sup>2</sup>	Contact closure interface	Yes	
L5 <sup>1</sup>	+24V AC/DC interface	No	1771-OB, 1771-OB16, 1771-OBB, 1771-OBD, 1771-OBN, 1771-OQ, 1771-OQ16, 1771-OYL, 1171-OZL
L8E <sup>2</sup>	+24V AC/DC interface	Yes	
L6 <sup>1</sup>	115V AC interface	No	1771-OA, 1771-OAD <sup>3</sup> , 1771-OW, 1771-OWN
L9E <sup>2</sup>	115V AC interface	Yes	

1 The L4, L5, and L6 options each have nine control inputs. You can select the function of each input through an L Option mode, which is covered later in this chapter.

2 The L7E, L8E, and L9E options are similar to the L4, L5, and L6 options with the addition of encoder feedback inputs.

3 Contact the factory for the recommended series/revision level.

**Important:** We do not recommend using an L4E, L5E, or L6E with the 1336 IMPACT drive.

**What Functions are Available?**

The L Option lets you choose a combination of the following functions:

Control function	Description
Accel/decel rates (2)	These inputs let you select the acceleration and deceleration times the drive uses. When single source inputs are used, <i>Accel Time 2/Decel Time 2</i> are selected when this input is high (1) and <i>Accel Time 1/Decel Time 1</i> are selected when this input is low (0). <sup>1</sup> When multiple source inputs are used, a separate Accel/Decel 1 and 2 are used. <sup>2c</sup>
Digital potentiometer (MOP)	These inputs increase or decrease the drive commanded speed when MOP (Manually Operated Potentiometer) is chosen as the speed command source. You can program the rate of increase or decrease.
Enable <sup>3</sup>	Removing this input disables the inverter and the motor coasts to a stop.
Flux enable	This input fluxes up the motor.
Fwd/Reverse	In single source modes, applying this input commands reverse direction and removing this input commands forward direction. <sup>1</sup> In multiple source modes, a separate forward and reverse are used. <sup>2</sup>
Jog	This input is a maintained (unlatched) start that follows the jog speed. When the jog input is removed, the motor stops by a ramp, current limit, or coast stop based on how you set <i>Logic Options</i> (parameter 17). <b>Note:</b> All starts must be low to jog.
Local control	Applying this input gives exclusive control of drive logic to the inputs at the L Option. No other devices may issue logic commands (excluding stop) to the drive.
Not Ext Flt <sup>4</sup>	This input is intended to fault the drive via external devices, such as motor thermoswitch and O.L. relays. Removing this input faults the drive and the motor stops according to how the stop type 1 bit is set in <i>Logic Options</i> (parameter 17).
Process trim	Applying this input enables the process trim function.
Ramp	Applying this input disables the ramp function. When the ramp function is disabled, the acceleration and deceleration times are set to 0.
Reset	Applying this input resets the drive.
Run forward <sup>5</sup>	Applying this input issues both a start command and a direction command to the drive. Removing this input stops the drive. The stop follows the stop type 1 specified in <i>Logic Options</i> (parameter 17).
Run reverse <sup>5</sup>	Applying this input issues both a start command and a direction command to the drive. Removing this input stops the drive. The stop follows the stop type 1 specified in <i>Logic Options</i> (parameter 17).
Speed selects (3)	These inputs choose the speed command source for the drive.
Speed/torque selections (3)	These inputs take exclusive control of <i>Spd/Trq Mode Sel</i> (parameter 68). This lets you switch between the speed and torque modes of the drive.
Start <sup>1,2</sup>	Applying this input issues a start command for the drive to begin accelerating to the commanded speed. A stop command is required to stop the drive. The stop follows the stop type in <i>Logic Options</i> . <b>Note:</b> All jogs must be low to start. A transition from jog to start without a start transition is allowed (the drive is jogging, you set a start, remove the jog, and the drive starts).
Not Stop, Clear Fault <sup>3</sup>	Removing this input issues a stop command for the drive. The drive stops according to the programmed stop mode based on <i>Logic Options</i> (parameter 17) and the selected stop mode, if applicable. If the drive has faulted, removing this input clears the fault if <i>Clr Flt/Res Mask</i> (parameter 127) is enabled.
Stop mode selects (2)	Applying this input indicates that the L Option stop input follows stop type 2 in <i>Logic Options</i> (parameter 17). Removing this input indicates that the L Option stop input follows stop type 1 in <i>Logic Options</i> . <b>Note:</b> Stop mode only affects the L Option stop. Stops commanded from a terminal (such as a Human Interface Module (HIM)) follow stop type 1 in <i>Logic Options</i> .
Speed Profiling	Mode 31 & 32 allow Speed Profiling to be accomplished through digital inputs. Refer to Chapter 9, <i>Applications</i> for more information on this feature.

1 Available only with three-wire control, single source.

2 Available only with three-wire control, multi source.

3 Must be asserted for operation.

4 Must be applied for operation if *L Option Mode* (parameter 116) is not 1 or disable the fault in *Fault Select 2* (parameter 22) and *Warning Select 2* (parameter 23).

5 Available only with two-wire control.

**Setting Up the L Option Board**

To use the L Option board, you need to:

1. Choose the L Option input mode that is best for your application.
2. Record the selected mode number:  
Selected Mode Number: \_\_\_\_\_
3. Wire the L Option board according to the input mode you selected.
4. Enter the input mode number during the digital set up portion of the start up procedure. The input mode is then used for the value of *L Option Mode* (parameter 116). This step is covered in Chapter 6, *Starting Up Your System*.

**Choosing the L Option Mode**

To choose the L Option mode that is best for your application, you need to:

1. Determine the type of start/stop/direction control you want.
2. Determine the remaining control functions that you want.
3. Use Table 5.A, Figure 5.1 and Figure 5.2 to determine the input mode number.

Table 5.A shows the available combinations. Figure 5.1 and Figure 5.2 also show the available combinations.

**Table 5.A**  
**Available Control Functions**

Control Function	Input Mode																															
	1	2	3	4	5	6	7	8	9	10	11	12	13	14	15	16	17	18	19	20	21	22	23	24	25	26	27	28	29	30	31	32
1st Accel											●																					
1st Decel											●																					
2nd/1st Decel <sup>1</sup>			●																													
2nd Accel			●								●		●																			
2nd Decel											●		●																			
Common	●	●	●	●	●	●	●	●	●	●	●	●	●	●	●	●	●	●	●	●	●	●	●	●	●	●	●	●	●	●	●	●
Enable	●	●	●	●	●	●	●	●	●	●	●	●	●	●	●	●	●	●	●	●	●	●	●	●	●	●	●	●	●	●	●	●
Flux Enable																	●		●				●									
Forward							●	●		●											●								●			
Jog	●					●	●																				●					
Local					●							●			●																	
MOP Dn <sup>2</sup>				●				●	●					●													●	●	●	●		
MOP Up <sup>2</sup>				●				●	●					●													●	●	●	●		
Not Ext Fault	●	●	●	●	●	●	●	●	●	●	●	●	●	●	●	●	●	●	●	●	●	●	●	●	●	●	●	●	●	●	●	●
Not Stop, Clr Flt	●	●	●	●	●	●	●	●	●	●	●	●	●	●	●	●	●	●	●	●	●	●	●	●	●	●	●	●	●	●	●	●
Proc Trim																	●		●				●		●							
Ramp																	●				●				●							
Reset																		●			●		●	●								
Reverse							●	●		●												●								●		
Rev/Fwd <sup>1,3</sup>	●	●	●	●	●												●	●										●				
Run Fwd												●	●	●	●	●							●	●	●	●				●		
Run Rev												●	●	●	●	●							●	●	●	●				●		
Spd Sel 1 <sup>4</sup>	●	●	●	●	●	●	●	●	●	●	●	●	●	●	●	●	●	●	●	●	●	●	●	●	●	●	●	●	●	●	●	●
Spd Sel 2 <sup>4</sup>	●	●	●	●	●	●	●	●				●	●	●	●	●	●					●	●	●	●	●	●	●	●	●	●	
Spd Sel 3 <sup>4</sup>	●	●					●	●				●	●													●		●				
Spd/Trq 1 <sup>5</sup>																			●	●		●										
Spd/Trq 2 <sup>5</sup>																				●	●		●									
Spd/Trq 3 <sup>5</sup>																				●	●		●									
Start		●	●	●	●	●	●	●	●	●	●						●	●	●	●	●	●					●	●	●			
Status	●																															
Stop Type <sup>1</sup>		●											●		●																	
Profile Enable																																●
Step Trigger																															●	●
Run Sequence																																●
Position Hold																																●

1 The L Option uses the first function (such as 1st Decel or Rev) when input is applied and the second function (such as 2nd Decel or Fwd) when input is not applied.

2 In modes 5, 9, 10, and 15, the MOP value is not reset to 0 when you stop. In modes 27, 28, 29, and 30, the MOP value is reset to 0 when you stop.

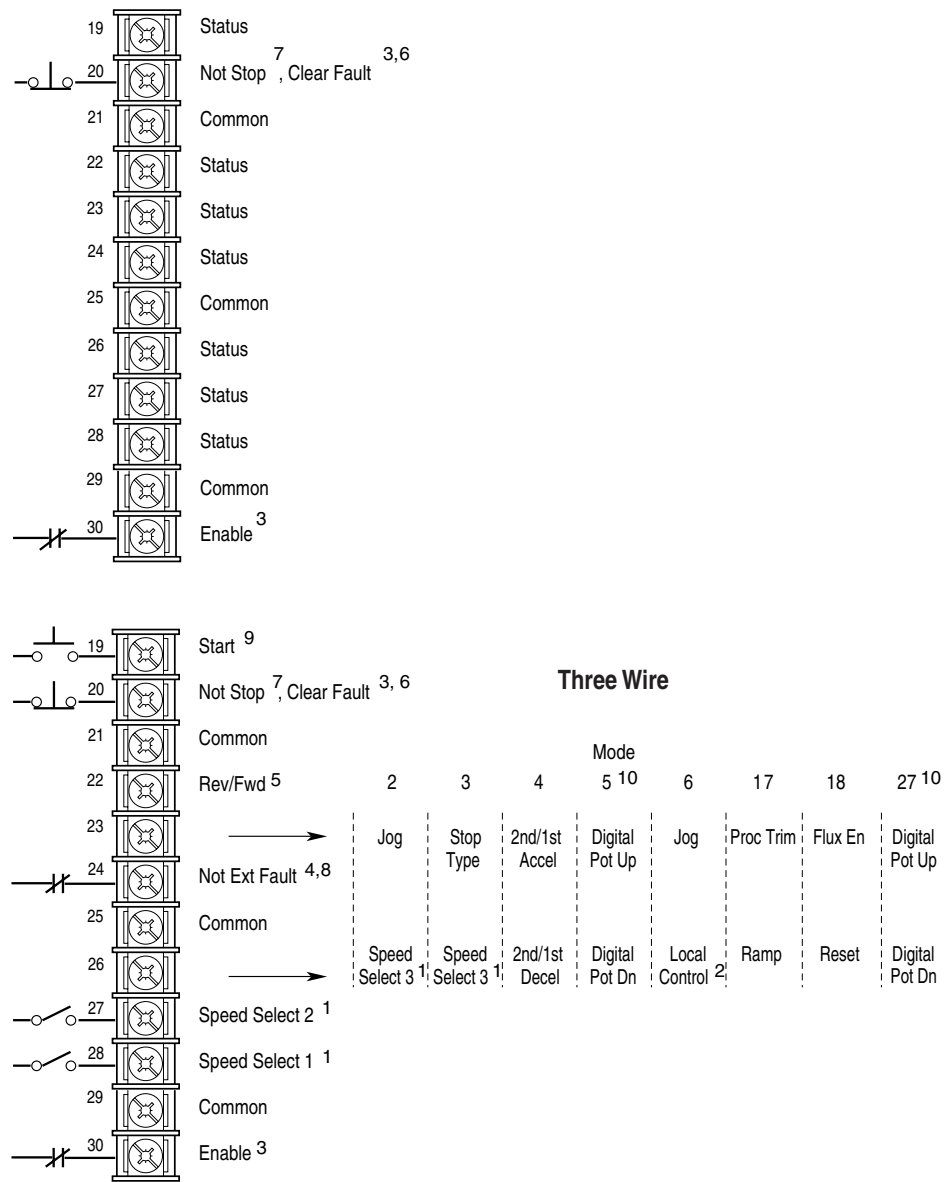
3 The L Option has ownership of direction. No other device on SCANport can control the direction.

4 The L Option has ownership of reference if all three selects are not available.

5 The L Option controls *Spd/Trq Mode Sel* (parameter 68).

NOTE: All Functions are enabled when input is applied and disabled when not applied.

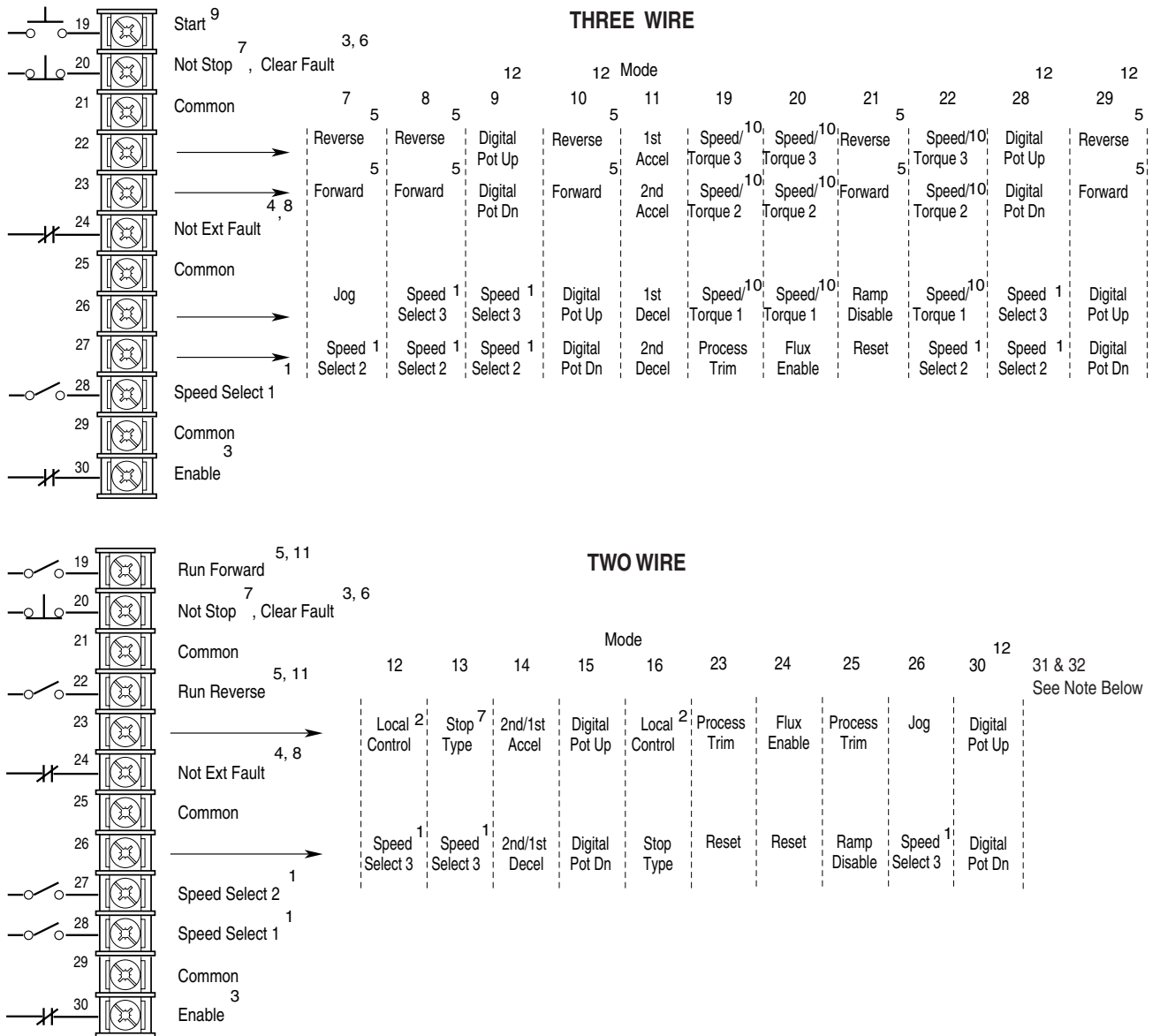
**Figure 5.1**  
**L Option Mode Selection and Typical TB3 Connections**



- 1 See Speed Select table.
- 2 Drive must be stopped to take Local Control. Control by all other adapters is disabled (except Stop).
- 3 These inputs must be present before drive will start.
- 4 For Common Bus, this becomes Precharge Enable.
- 5 Bit 11 of *Logic Options* (parameter 17) must be 0 for reverse direction control.
- 6 For soft faults only. You need to recycle power to the drive or reset to clear hard faults. For hard faults, refer to the *Troubleshooting* chapter.
- 7 To configure the stop type, refer to *Logic Options* (parameter 17). **Note:** This only affects the L Option stop. For modes that do not have Stop Type, stop commands follow Stop 1 in *Logic Options*.
- 8 This input must be present before the fault can be cleared and the drive will start. This can be disabled through *Fault Select 2* (parameter 22) and *Warning Select 2* (parameter 23).
- 9 Latched (momentary) starts require a stop to stop the drive.
- 10 In mode 5, the MOP value is not reset to 0 when you stop. In mode 27, the MOP value is reset when you stop.



**Figure 5.2**  
**L Option Mode Selection and Typical TB3 Connections**



- 1 See Speed Select table.
  - 2 Drive must be stopped to take Local Control. Control by all other adapters is disabled (except Stop).
  - 3 These inputs must be present before drive will start.
  - 4 For Common Bus, this becomes Precharge Enable.
  - 5 Bit 11 of *Logic Options* (parameter 17) must be 0 for reverse direction control.
  - 6 For soft faults only. You need to recycle power to the drive to clear. For hard faults, refer to the *Troubleshooting* chapter.
  - 7 To configure the stop type, refer to *Logic Options* (parameter 17).
  - 8 This input must be present before the fault can be cleared and the drive will start. This can be disabled through *Fault Select 2* (parameter 22) and *Warning Select 2* (parameter 23).
  - 9 Latched starts require a stop to stop the drive. **Note:** This only affects the L Option stop. For modes that do not have Stop Type, stop commands follow Stop 1 in *Logic Options*.
  - 10 See Speed/Torque Select table. This takes precedence over Spd/Trq Mode Sel (parameter 68).
  - 11 Unlatched (maintained) start.
  - 12 In modes 5, 9, 10, and 15, the MOP value is not reset to 0 when you stop. In modes 27, 28, 29, and 30, the MOP value is reset to 0 when you stop.
- NOTE:** For detailed information on Modes 31 and 32 which were added for Speed Profiling applications, refer to page 9-23 in this manual.

### Entering the Input Mode into the Input Mode Parameter

During the start up procedure, you will be prompted for the L Option mode number. The drive enters the number you select at this prompt into *L Option Mode* (parameter 116).

### Changing the Input Mode

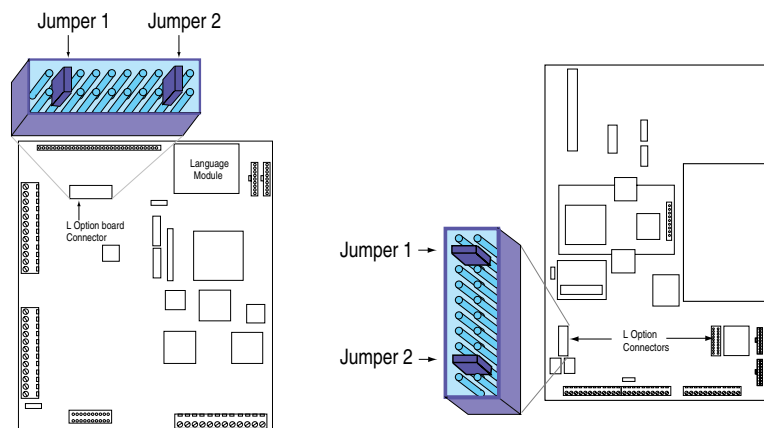
You can change *L Option Mode* at any time either by re-running the start up procedure or by changing *L Option Mode* directly. The start up procedure is the preferred method. If you change *L Option Mode* directly, the change does not take affect until you reset the drive or complete the following steps:

1. Remove power to the drive.
2. Let the bus voltage decay completely.
3. Restore power to the drive.

When you restore the power, the drive uses the new input mode value to determine the function of the L Option inputs.

You may also need to manually adjust several other parameters that the start up procedure prompts you for.

**Important:** If you do not have an L Option board installed, you must set *L Option Mode* to 1 (default) and install jumpers. If the drive was shipped from the factory without the option, these jumpers will have been installed.



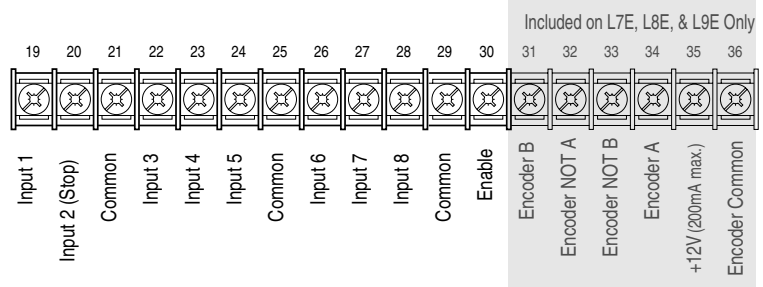
### Wiring the L Option Board

TB3 accepts wire with the following specifications:

Wire information	Description
Minimum wire size	0.30 mm <sup>2</sup> (22 AWG)
Maximum wire size	2.1 mm <sup>2</sup> (14 AWG)
Maximum torque	1.36 N-m (12 lb.-in.)
Wire type	Use only copper wire

Figure 5.3 provides the terminal designations for TB3.

**Figure 5.3**  
**TB3 Terminal Designations**



### Speed Select/Speed Reference

Several sources can provide the speed reference to the drive. A SCANport device or the L Option determine the source.

The default source for a command reference (all speed select inputs open) is *Speed Ref 1*. If any of the speed select inputs are closed, the drive uses other parameters as the speed reference source.

The following table defines the input state of the Speed Select inputs for a desired speed reference source:

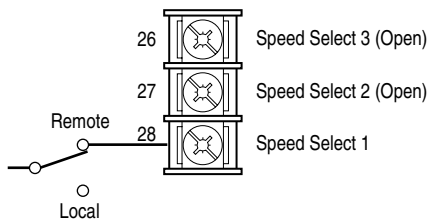
Speed select 3	Speed select 2	Speed select 1	Frequency source:
Open	Open	Open	Speed Ref 1
Open	Open	Closed	Speed Ref 2
Open	Closed	Open	Speed Ref 3
Open	Closed	Closed	Speed Ref 4
Closed	Open	Open	Speed Ref 5
Closed	Open	Closed	Speed Ref 6
Closed	Closed	Open	Speed Ref 7
Closed	Closed	Closed	Last State

Closed = Applied = 1  
Open = Removed = 0

#### Example 1

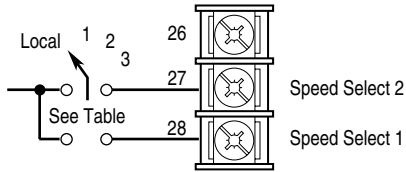
For the first example, input mode 2 has been selected. The application calls for a local Human Interface Module (HIM) speed command or remote 4 – 20mA from a PLC. To program the drive for this example:

1. Set the value of *SP An In1 Select* (parameter 133) to 1.
2. Set the value of *SP An In1 Scale* (parameter 135) to 0.125.
3. Link *SP An In1 Value* (parameter 134) to *Speed Ref 1* (parameter 29).
4. Set *mA In Offset* (parameter 103) to 0.
5. Set *mA In Scale* (parameter 104) to 2.
6. Link *mA In Value* (parameter 102) to *Speed Ref 2* (parameter 31).



file: Interface/Comm  
group: SCANport Analog

file: Interface/Comm  
group: Analog Inputs



With Speed Select inputs 2 and 3 open and the selector switch set to Remote (Speed Select 1 closed), the drive follows *Speed Ref 2* (parameter 31) or 4 – 20mA. With the switch set to Local (Speed Select 1 open), all speed select inputs are open and the drive follows the local HIM *Speed Ref 1* (parameter 29).

### Example 2

For the second example, input mode 7 has been selected. The application follows a local HIM unless a preset speed is selected. To program the drive for this example:

1. Set the value of *SP An In1 Select* (parameter 133) to 1.
2. Set the value of *SP An In1 Scale* (parameter 135) to 0.125.
3. Link *SP An In1 Value* (parameter 134) to *Speed Ref 1* (parameter 29).
4. Set *Speed Ref 2* (parameter 31) to 10 rpm.
5. Set *Speed Ref 3* (parameter 32) to 50 rpm.
6. Set *Speed Ref 4* (parameter 33) to 100 rpm.

The following table shows how the contacts operate for the speed select switch. Because Input Mode 7 does not offer a Speed Select 3 input, Speed Ref 4 – 7 are not available.

Switch position	Speed select input		Parameter used for speed reference	Programmed setting
	1 (#28)	2 (#27)		
Local	Open	Open	Speed Ref 1	(HIM) 0 — base speed
1	Closed	Open	Speed Ref 2	10 rpm
2	Open	Closed	Speed Ref 3	50 rpm
3	Closed	Closed	Speed Ref 4	100 rpm

### Speed/Torque Selection

The following table defines the input state of the speed/torque mode select inputs for a desired speed/torque mode.

Speed/ torque mode select 3	Speed/ torque mode select 2	Speed/ torque mode select 1	Speed/torque mode:
Open	Open	Open	Zero torque
Open	Open	Closed	Speed regulate
Open	Closed	Open	Torque regulate
Open	Closed	Closed	Minimum torque/speed
Closed	Open	Open	Maximum torque/speed
Closed	Open	Closed	Sum of the torque and speed
Closed	Closed	Open	Zero torque
Closed	Closed	Closed	Zero torque

Closed = Applied = 1  
Open = Removed = 0

Refer to the Torque Reference Overview section of Appendix B, *Control Block Diagrams*, for additional information about speed and torque selection.

**Using an Encoder with the L Option Board**

If you have an L7E, L8E, and L9E board, you need to complete the following steps to use the encoder:

1. Ground the encoder the cable shield.

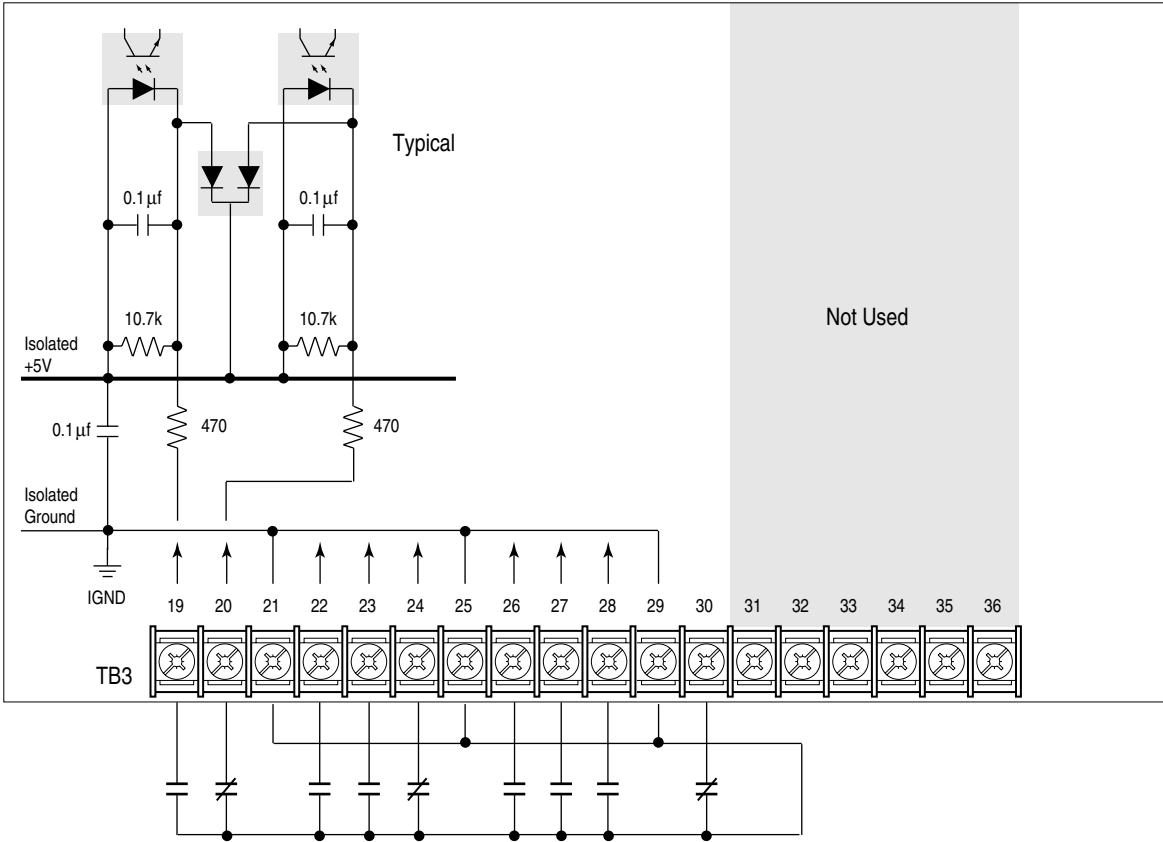
If your drive is a(n):	Ground the encoder to the following location on the control board:
A1, A2, A3, or A4 frame	J7 pin 9, 6, or 3
B, C, D, E, F, G, or H frame	TB10 pin 20, 17, 12, 9, or 6

2. Set the encoder voltage jumper to match the encoder used (J1/J2:5V/12V) on the L Option board.
3. Connect phase A, phase A NOT, phase B, and phase B NOT.
4. Connect the power to the encoder.

**Requirements for the Contact Closure Interface Board (L4)**

Figure 5.4 shows the wiring diagram for the L4 Option board.

**Figure 5.4**  
**L4 Option Board Wiring Diagram**



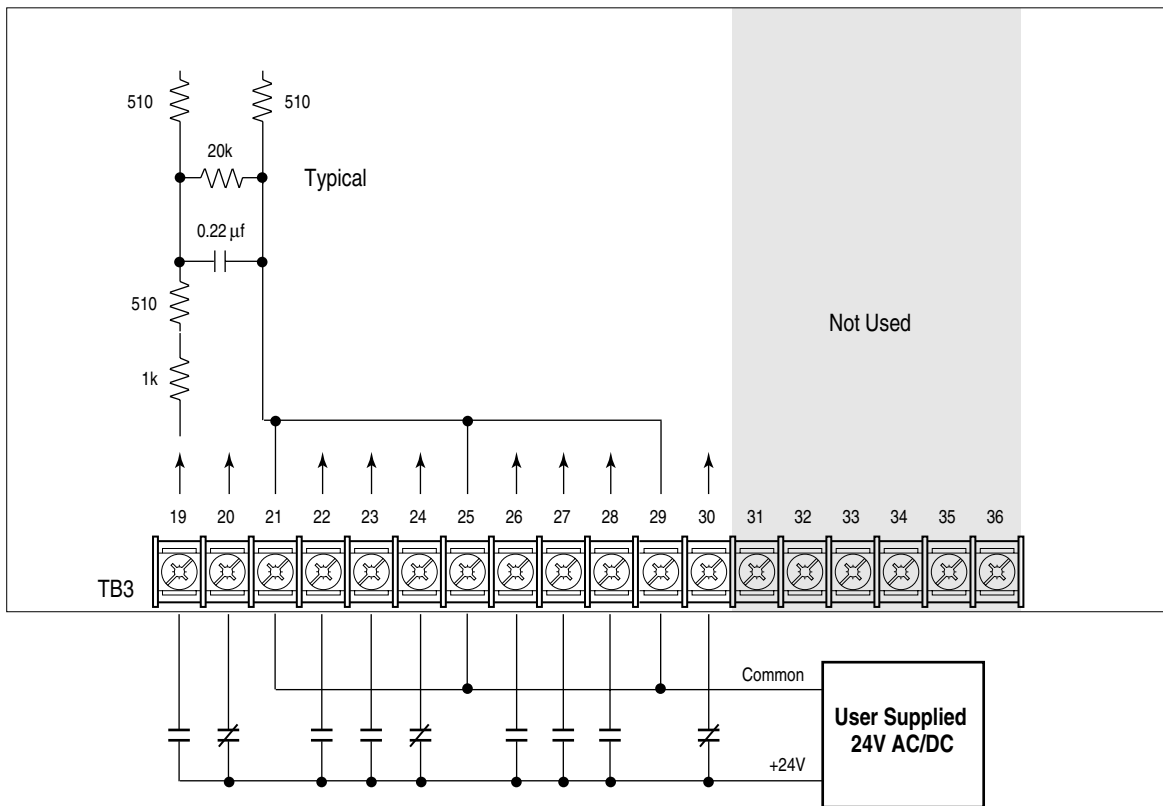
Circuits used with the L4 Option board must be able to operate with low = true logic. Reed type input devices are recommended.

In this state:	External circuits must:
low	Be capable of a sinking current of approximately 10 mA to pull the terminal voltage low to 3.0V DC or less.
high	Let the terminal voltage rise to a voltage of 4.0 – 5.0V DC

**Requirements for the 24V AC/DC Interface Board Requirements (L5)**

Figure 5.5 shows the wiring diagram for the L5 Option board.

**Figure 5.5  
L5 Option Board Wiring Diagram**



Circuits used with the L5 Option board must be able to operate with high = true logic.

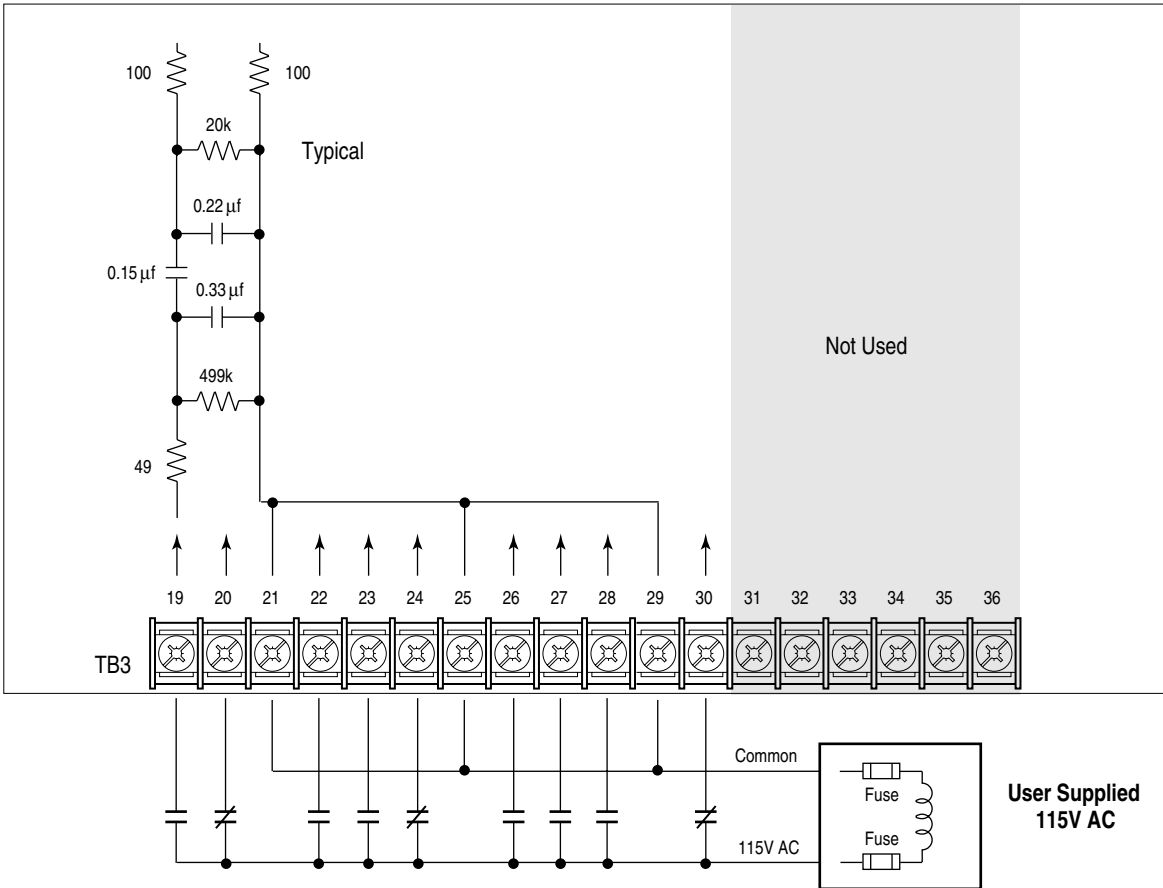
In the low state, this type of external circuit:	Must generate a voltage of no more than:	And, leakage current must be less than:
DC	8V DC	1.5 mA into a 2.5K ohm load
AC	10V AC	2.5 mA into a 2.5K ohm load

Both AC and DC external circuits in the high state must generate a voltage of +20 to +26 volts and source a current of approximately 10 mA for each input.

### Requirements for the 115V AC Interface Board (L6)

Figure 5.6 shows the wiring diagram for the L6 Option board.

**Figure 5.6**  
**L6 Option Board Wiring Diagram**



Circuits used with the L6 Option board must be able to operate with high = true logic.

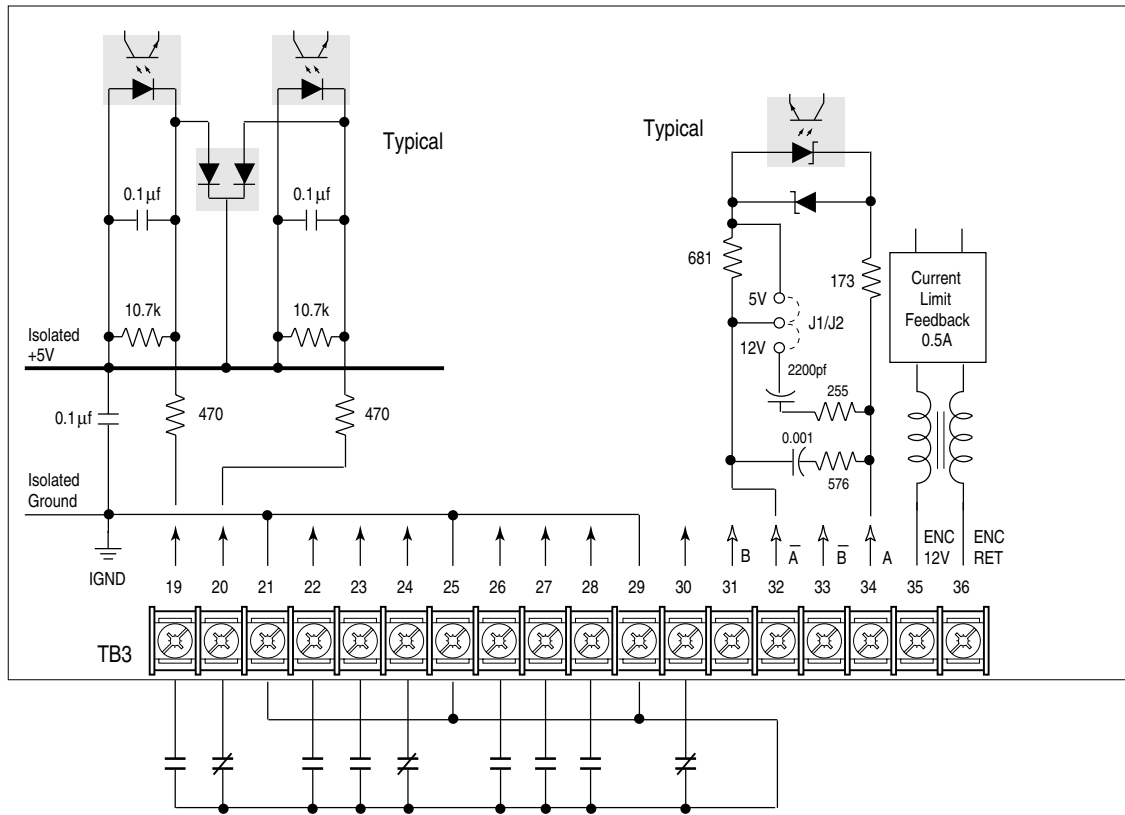
In this state:	Circuits must generate a voltage of:
low	No more than 30V AC. Leakage current must be less than 10 mA into a 6.5K ohm load.
high	90 – 115V AC ±10% and source a current of approximately 20 mA for each input.

**Important:** The series B 115V AC Interface Board (L6) is equivalent to the 115V AC Interface Board (L9E). Refer to page 5-16 for a description.

**Requirements for the Contact Closure Interface Board (L7E)**

Figure 5.7 shows the wiring diagram for the L7E Option board.

**Figure 5.7  
L7E Option Board Wiring Diagram**



Circuits used with the L7E Option board must be able to operate with low = true logic. Reed type input devices are recommended.

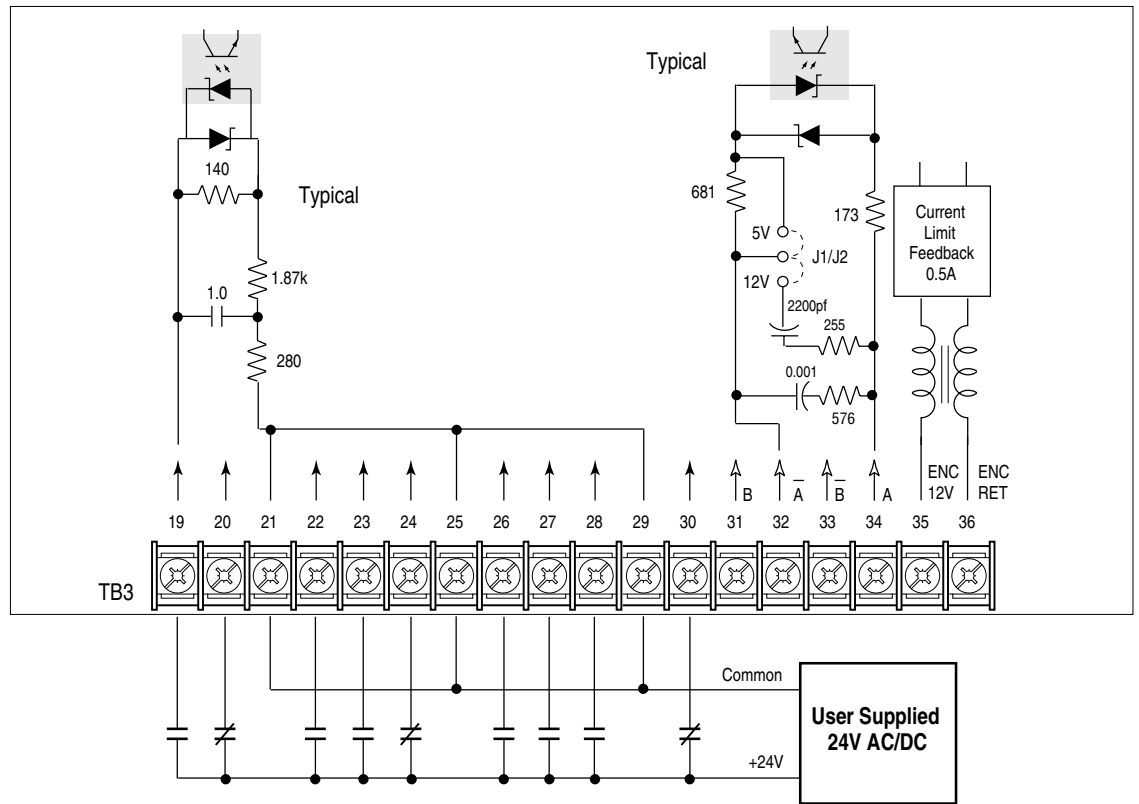
In this state:	External circuits must:
low	Be capable of a sinking current of approximately 10 mA to pull the terminal voltage low to 3.0V DC or less.
high	Let the terminal voltage rise to a voltage of 4.0 – 5.0V DC.



**Requirements for the  
24V AC/DC Interface Board  
Requirements (L8E)**

Figure 5.8 shows the wiring diagram for the L8E Option board.

**Figure 5.8  
L8E Option Board Wiring Diagram**



Circuits used with the L8E Option board must be able to operate with high = true logic.

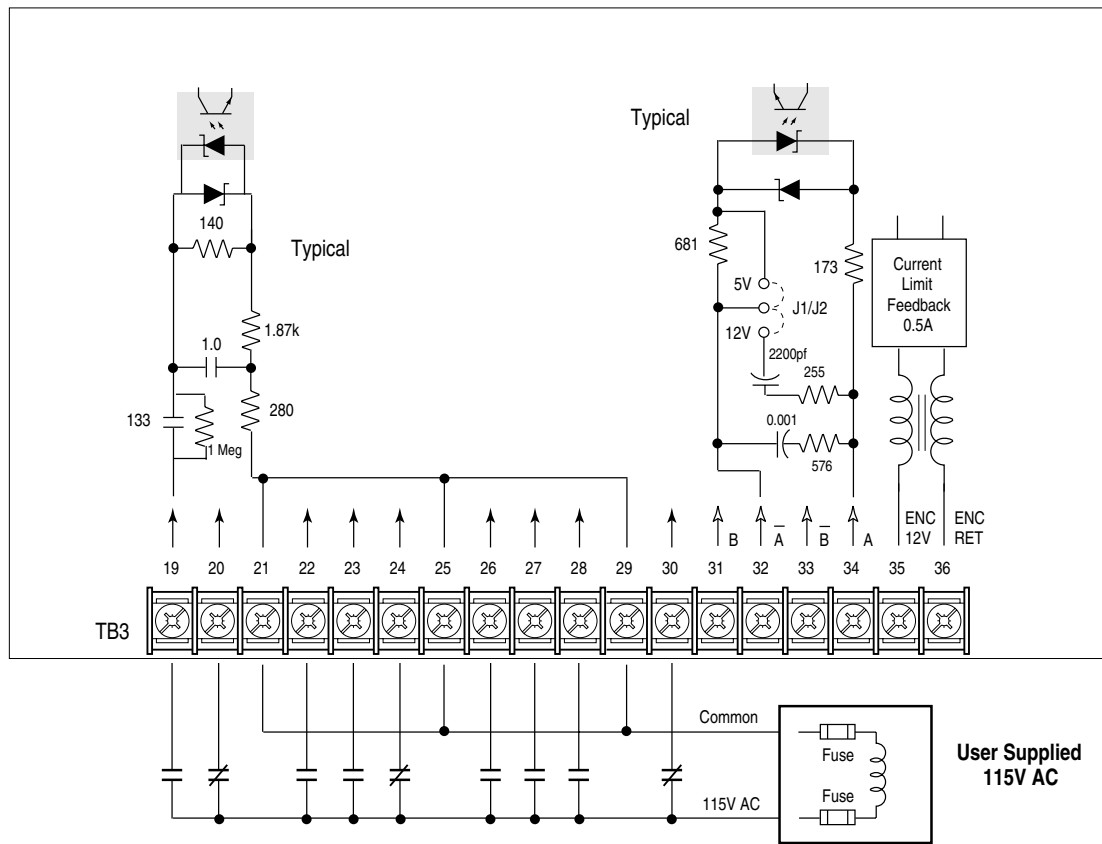
In the low state, this type of external circuit:	Must generate a voltage of no more than:	And, leakage current must be less than:
DC	8V DC	1.5 mA into a 2.5K ohm load
AC	10V AC	2.5 mA into a 2.5K ohm load

Both AC and DC external circuits in the high state must generate a voltage of +20 to +26 volts and source a current of approximately 10 mA for each input.

### Requirements for the 115V AC Interface Board (L9E)

Figure 5.9 shows the wiring diagram for the L9E Option board.

**Figure 5.9**  
**L9E Option Board Wiring Diagram**



Circuits used with L9E Option board must be able to operate with high = true logic.

In this state:	Circuits must generate a voltage of:
low	No more than 30V AC. Leakage current must be less than 10 mA into a 6.5K ohm load.
high	90 – 115V AC $\pm$ 10% and source a current of approximately 20 mA for each input.

## Starting Up Your System

Chapter 6 provides information so that you can start up your system.

### Chapter Objectives

This Topic:	Starts on Page:
Before applying power to your drive	6-1
Applying power to your drive	6-3
Recording your drive and motor information	6-3
Using the Human Interface Module (HIM)	6-4
Starting up your system	6-7
Running Quick Motor Tune	6-8
Running Digital Setup	6-10
Running Analog Setup	6-11
Understanding links	6-12
Where should I go from here?	6-14

**Important:** We recommend that you run the start up sequence to start up your system most easily.

### Before Applying Power to Your Drive

Before you apply voltage to your system, you should:

- Check the drive for any damage that may have occurred during shipment and installation.
- Verify that all jumpers and configuration controls are properly set for your application.
- Check all wiring external to the drive for accuracy and reliability.
- Verify that all external I/O wires are properly terminated in the terminal blocks.
- Perform a full point-to-point continuity check on all I/O wiring connected to the drive.
- Verify that the incoming power connections are properly connected and tight.
- Verify that the power source is properly sized and protected for your particular drive.
- Verify that the motor power connections are properly connected and tight.
- Check the motor phasing. Motor phase A should be connected to drive output phase A. Likewise, phase B and C should be properly terminated to their respective terminals. This phasing is double-checked during the start up procedure.
- For H frame drives, verify phasing of incoming power for correct rotation of the 3 phase, top mounted fan.
- Verify that the Pulse Input Voltage Selection jumper is set correctly for your application.

If your input voltage is:	Then jumper J8 (frames A1 – 14)/J4 (frames B – H) should be across:
+5V DC	Pins 1 and 2
+12V DC	Pins 2 and 3

If you are using an encoder attached to your L Option board, you should also:

- Verify that the encoder feedback device is properly connected. The encoder should be a quadrature device with a 12V input power requirement and either 12V or 5V differential outputs. Jumpers J1 and J2 on the L Option board must be set for the desired output. The jumper settings for J1 and J2 must match.
- Verify that the L Option board, if present, is wired properly.
- Check the phasing of the encoder. A and A NOT as well as B and B NOT must be properly terminated. This phasing is double checked during the start up procedure.

### Starting and Stopping the Motor



**ATTENTION:** The drive start/stop control circuitry includes solid-state components. If hazards due to accidental contact with moving machinery or unintentional flow of liquid, gas, or solids exist, an additional hardwired stop circuit is required to remove AC line power to the drive. When AC power is removed, there is a loss of inherent regenerative braking effect and the motor coasts to a stop. An auxiliary braking method may be required.

### Repeated Application/Removal of Input Power



**ATTENTION:** The 1336 IMPACT drive is intended to be controlled by control input signals that start and stop the motor. A device that routinely disconnects and then reapplies line power to the drive for the purpose of starting and stopping the motor is not recommended. If you use this type of circuit, a maximum of 3 stop/start cycles in any 5 minute period (with a minimum 1 minute rest between each cycle) is required. Ten minute rest cycles must separate these 5 minute periods to let the drive precharge resistors cool. Refer to codes and standards applicable to your particular system for specific requirements and additional information.

## Applying Power to Your Drive

When the pre-power checks are completed, apply incoming power. System design determines how you apply power. Make sure that you know the safety controls associated with your system before applying power. Only apply power if you thoroughly understand the 1336 IMPACT drive and the associated system design.

Measure the incoming line voltage between L1 & L2, L2 & L3, and L1 & L3. Use a Digital Multimeter (DMM) on AC volts, highest range (1000V AC). The input voltage should equal the drive rated input voltage present on the drive's nameplate within  $\pm 10\%$ . If the voltage is out of tolerance, verify that the drive rating is correct for the application. If it is correct, adjust the incoming line voltage to within  $\pm 10\%$ . Refer to Appendix D, *Derating Guidelines*, for the drive current derating requirements for voltages above nominal to +10%.

## Recording Your Drive and Motor Information

Record the following information. You will need this information for the start up routine and for any future servicing, if needed.

**Table 6.A**  
**Drive and Motor Information**

### Drive Nameplate Data

Catalog Number: \_\_\_\_\_  
 Serial Number: \_\_\_\_\_  
 Series: \_\_\_\_\_  
 AC Input: \_\_\_\_\_ Volts: \_\_\_\_\_ Amps: \_\_\_\_\_  
 AC Output: \_\_\_\_\_ Volts: \_\_\_\_\_ Amps: \_\_\_\_\_  
 Horsepower Rating: \_\_\_\_\_ kW: \_\_\_\_\_

### Motor Nameplate Data

Catalog Number: \_\_\_\_\_  
 Serial Number: \_\_\_\_\_  
 Series: \_\_\_\_\_  
 AC Input: \_\_\_\_\_ Volts: \_\_\_\_\_ Amps: \_\_\_\_\_  
 Horsepower Rating: \_\_\_\_\_ kW: \_\_\_\_\_  
 Poles: \_\_\_\_\_ (May be located on the nameplate.)  
 RPM: \_\_\_\_\_  
 Hz: \_\_\_\_\_

### Encoder Nameplate Data

Catalog Number: \_\_\_\_\_  
 Serial Number: \_\_\_\_\_  
 Series: \_\_\_\_\_  
 Input Power Supply: \_\_\_\_\_ Volts  
 Input Signal Level: \_\_\_\_\_ Volts  
 Output Signal Level: \_\_\_\_\_ Volts  
 Output Type: \_\_\_\_\_  
 Pulse Per Revolution: \_\_\_\_\_ PPR  
 Maximum Speed: \_\_\_\_\_  
 Maximum Frequency: \_\_\_\_\_

### Revision Levels

Main Control Board: \_\_\_\_\_  
 Gate Driver Board: \_\_\_\_\_

### Jumper Settings

(Board Dependent)

\_\_\_\_\_  
 \_\_\_\_\_

## Understanding the Basics of the Human Interface Module (HIM)

The Human Interface Module (HIM) is the standard user interface for the 1336 IMPACT drive.

**Important:** For more information about the HIM, refer to Appendix C, *Using the Human Interface Module (HIM)*.

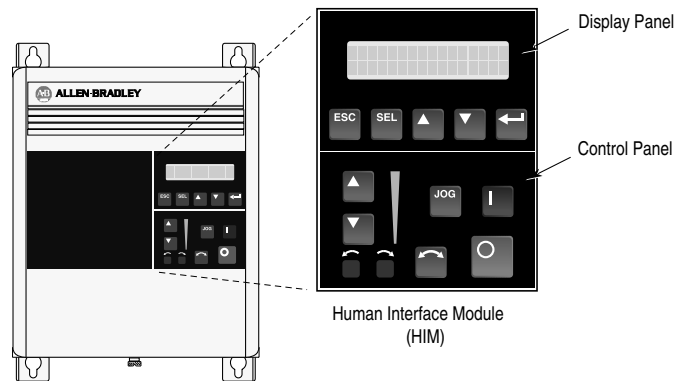
**Important:** The start up procedure described in this manual assumes that you are using a HIM. If you are using another programming device, such as a Graphic Programming Terminal (GPT), refer to the instructions for that programming device and modify the start up instructions in this manual accordingly.

**Important:** Your HIM should be connected to SCANport 1 for all HIM functions to work correctly. The defaults have been set up for the HIM to be connected to port 1. If you plug the HIM into a different port, you need to change the default links.






The HIM contains a display panel and a control panel. The display panel lets you program the drive and view the various operating parameters. The control panel lets you control different drive functions.

Figure 6.1 shows an example of a HIM.







**Figure 6.1**  
Example of a HIM





The display panel provides the following keys:

Press this key:	To:	This key is referred to as:
	Go back one level in the menu tree that the HIM uses to organize information.	The Escape key
	Alternate which display line (top or bottom) is currently active.	The Select key
	Increment (increase) the selected value. If no value is selected, use this key to scroll through the groups or parameters currently selected.	The Increment key
	Decrement (decrease) the selected value. If no value is selected, use this key to scroll through the groups or parameters currently selected.	The Decrement key
	Select the group or parameter that is currently active or enter the selected parameter value into memory. The top line of the display automatically becomes active to let you choose another parameter or group.	The Enter key

The HIM provides the following keys for the control panel section:

Press this key:	To:	This key is referred to as:
	Start operation if the hardware is enabled and no other control devices are sending a Stop command.	The Start key
	Initiate a stop sequence.	The Stop key
	Jog the motor at the specified speed. Releasing the key stops the jog.	The Jog key
	Change the motor direction. The appropriate Direction Indicator light will light to indicate direction.	The Change Direction key
 	Increase or decrease the HIM speed command. An indication of this command is shown on the visual Speed Indicator. Pressing both keys simultaneously stores the current HIM speed command in HIM memory. Cycling power or removing the HIM from the drive sets the speed command to the value stored in HIM memory. These arrows are only available with digital speed control.	The Up Arrow and Down Arrow keys

The control panel section also provides the following indicators:

This indicator:	Provides information about:	This is referred to as:
	The direction of motor rotation.	The Direction LED
	An approximate visual indication of the command speed. This indicator is only available with digital speed control.	The Speed Indicator

When you first apply power to the 1336 IMPACT drive, the HIM cycles through a series of displays. These displays show the drive name, HIM ID number, and communication status. When complete, the status display shown in Figure 6.2 is displayed.

**Figure 6.2**  
**Initial Status Display**

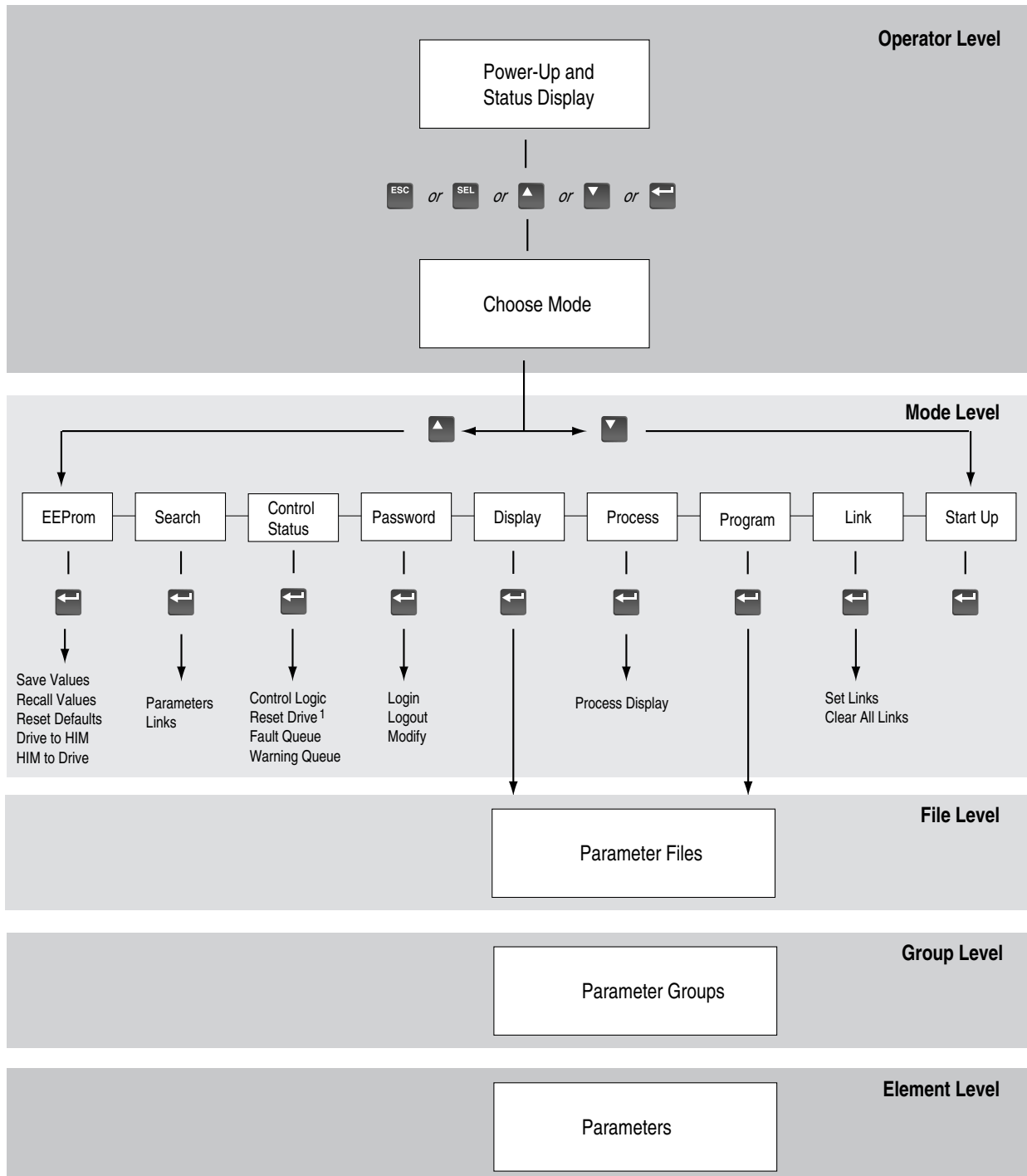


The display shows the current drive status or any faults that may be present. During the start up procedure, you will need to answer the questions that are displayed in the status display area.

Press any key on the HIM to continue.

Before you begin the start up procedure, you should have a basic understanding of how the HIM uses a menu tree to organize the information that the HIM displays. Figure 6.3 shows the generic HIM menu tree used by all devices that support the HIM.

**Figure 6.3**  
**HIM Menu Tree**



<sup>1</sup> Not available before Version 1.06 Series B.



## Starting Up Your System

Once you are familiar with the HIM, you can begin the start up procedure.



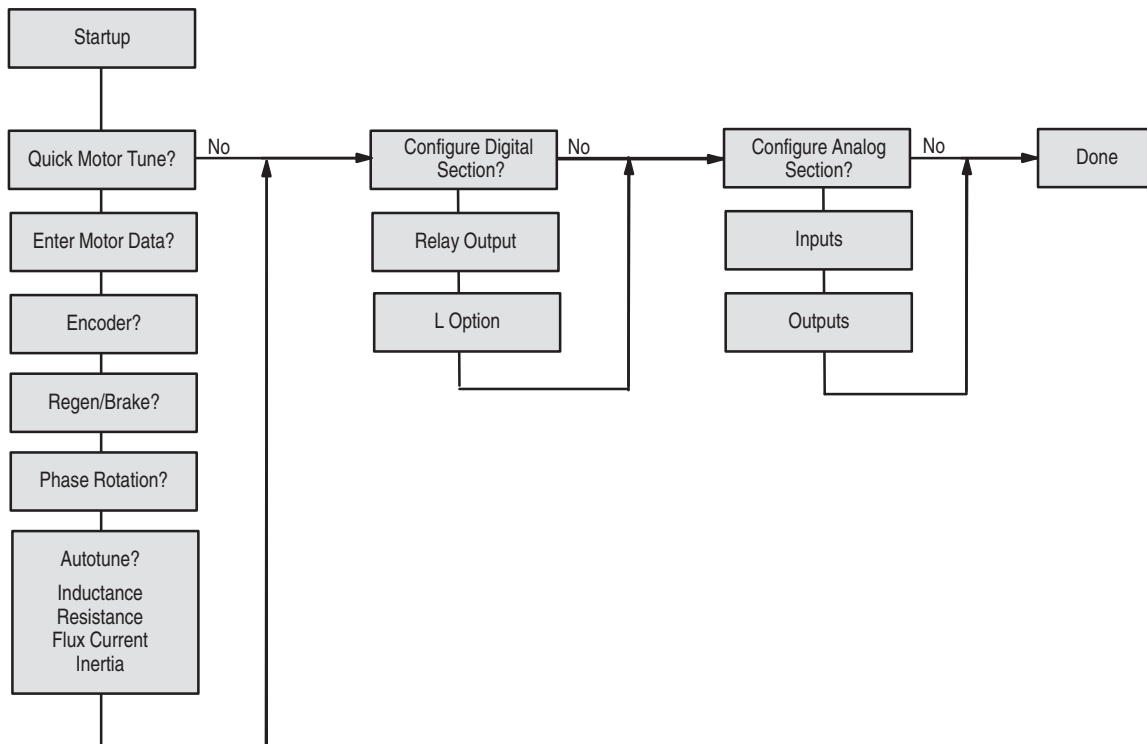
**ATTENTION:** During the start up procedures, the motor will rotate. Hazard of personal injury exists due to unexpected starts, rotation in the wrong direction, or contact with the motor shaft.

If possible, uncouple the motor from the load and place a guard around the motor shaft.

Make sure the motor is securely mounted before beginning this procedure.

Figure 6.4 shows the outline for the start up procedure for the 1336 IMPACT drive.

**Figure 6.4**  
**Start Up Procedure**



This start up procedure is designed to be a fast, basic start up. It does not address all available functions and options. You should use this start up procedure to get your basic system running and then adjust any remaining parameters that you need for your particular application.

To begin the start up procedure from the *Choose Mode/Startup* prompt, you need to follow these steps:

Step:	At this prompt:	You need to:	Then go to:
1.	Choose Mode Start Up	Press the ENTER key.	Step 2
2.	Quick Motor Tune Procedure? Y	Decide if you want to run the Quick Motor Tune routine. The quick motor tune routine includes entering your basic drive/motor nameplate data, verifying that your motor and encoder (if used) leads are connected correctly, and running the auto-tune tests. If yes, press the ENTER key.	Running the Quick Motor Tune Procedure
		If no, press INC or DEC to get N. Then press ENTER.	Step 3
3.	Config Digital Section? N	Decide if you need to configure the digital input and output parameters. The digital section includes the set up information for the programmable relay and the L Option board. If yes, press INC or DEC to get Y. Then press ENTER.	Configuring the Digital Section
		If no, press the ENTER key.	Step 4
4.	Setup Reference Analog/PPR IO? N	Decide if you need to configure the analog input and output parameters. The analog section includes the set up information for the following inputs and outputs: Speed Reference 1, Speed Reference 2, Torque Reference, Analog Output 1, Analog Output 2, and the HIM status display. If yes, press INC or DEC to get Y. Then press ENTER.	Configuring the Analog Section
		If no, press ENTER.	Step 5
5.	Startup Complete	Press ENTER.	

When you have finished the start up procedure and pressed ENTER, you are placed at the following prompt:



To continue, press ENTER. To go back to the start up routine:


1. Press either INC or DEC to toggle Completed to Reset Sequence.
2. Press ENTER.

The 1336 IMPACT drive retains any information that you have already entered. Choosing *Reset Sequence* lets you re-enter the start up routine.

## Running the Quick Motor Tune Procedure

The Quick Motor Tune procedure helps you set up your basic drive parameters, verify that your motor and encoder (if used) leads are connected correctly, and run the auto-tune tests. You should set this information up the first time you run the start up procedure.

Follow these steps to complete the Quick Motor Tune procedure:

Step:	At this prompt:	You need to:	Go to:
1.	Enter Nameplate Motor Data? Y	Decide if you want to enter the nameplate motor data. If no, press INC or DEC to get N. Then press ENTER.	Step 3
		If yes, press ENTER. You are asked to provide the following motor information for: <ul style="list-style-type: none"> <li>Nameplate HP (the horsepower rating)</li> <li>Nameplate Volts (the voltage rating)</li> <li>Nameplate Amps (the current rating)</li> <li>Nameplate Hz (the frequency rating)</li> <li>Nameplate RPM (the rated speed)</li> <li>Motor Poles (the number of motor poles)</li> </ul> For each item you need to do the following: <ol style="list-style-type: none"> <li>Press SEL to make the bottom display line active.</li> <li>Use INC or DEC to enter the correct value.</li> <li>When the value is correct, press ENTER to return to the top line.</li> <li>Press ENTER again.</li> </ol>	Step 2
2.	Do you have an Encoder? N	If you are not using an encoder, press ENTER.	Step 4
		If you are using an encoder, use INC or DEC to toggle the N to a Y. Press ENTER.	Step 3
3.	Encoder PPR xxxx	Press SEL to make the bottom display line active. Use INC or DEC to enter the pulses per revolution that your encoder uses. When the value is correct, press ENTER to return to the top line. Press ENTER again.	Step 4
4.	Is there Regen/ Dynamic Brake? N	If you are not using a dynamic brake or regenerative system, press ENTER. If you are using a dynamic brake or regenerative system, use INC or DEC to toggle the N to a Y. Press ENTER.	Step 5
5.	Rotation Test. Press GREEN STRT	Press START.	Step 6
6.	Is the Motor Rotating? Y	If the motor is rotating, press ENTER. If the motor is not rotating, go to Chapter 12, <i>Troubleshooting</i> .	Step 7
7.	Is the Rotation Direction Fwd? Y	If the motor is rotating in what you consider to be the forward direction, press ENTER. Otherwise, you will be asked to stop the drive by pressing STOP. You then need to exit start up and change the motor leads.	Step 8
8.	STOP Drive Press RED button.	Press STOP.	Step 9
9.	Tune Drive with 50% Current? Y	If you want to run the auto-tune tests with 50% motor current, press ENTER. If 50% motor current is not enough to run the tests on your system, the start up procedure will time out and let you increase the percentage. To use a different percentage of current: <ol style="list-style-type: none"> <li>Use INC or DEC to toggle the Y to an N.</li> <li>Press ENTER.</li> <li>Press SEL.</li> <li>Use INC or DEC to enter the percentage you want to use.</li> <li>Press ENTER.</li> </ol>	Step 10
10.	Motor May Rotate Press GREEN STRT	Press START. The inductance, resistance, flux current, and inertia tests are run at this time. The display section shows you which auto-tune test is currently running.	Step 11
		 <b>ATTENTION:</b> Hazard of personal injury exists. Even though the motor may not rotate during the first three tests, the motor will rotate during the inertia test.	
11.	Tune Complete Press ENTER	Press ENTER.	

**Configuring the Digital Section**

Follow these steps to configure the digital section:

Step:	At this prompt:	You need to:	Go to:
1.	Configure the Relay Output? Y	Press ENTER if you want to set up the relay output.	Step 2
		If you do not want to set up the relay output, use INC or DEC to toggle the Y to an N. Press ENTER.	Step 4
2.	Relay Config 1 At Set Speed	Press SEL. Decide what you want the function of TB10 pins 1 and 2 (for frames A1 – A4) or TB11 pins 1 and 2 (for frames B – H) to be. These functions are listed in the description of <i>Relay Config 1</i> (parameter 114) in Chapter 11, <i>Parameters</i> . Enter the appropriate value. When the value is correct, press ENTER to return to the top line. Press ENTER again.	
		If you selected $\geq$ Speed, < Speed, $\geq$ Current, < Current.	Step 3
		Otherwise:	Step 4
3.	Relay Setpoint 1 +x.x%	Press SEL. Use INC or DEC to enter the setpoint threshold for either speed or current. When the value is correct, press ENTER to return to the top line. Press ENTER again.	Step 4
4.	Configure the L Options Board? Y	Press ENTER if you want to set up the L Option information.	Step 5
		If you do not want to set up the L Option, use INC or DEC to toggle the Y to an N. Press ENTER.	Step 6
5.	L Option mode #	Press SEL. Use INC or DEC to select the L Option mode that you want to use. Refer to Chapter 5 and the description of <i>L Option Mode</i> (parameter 116) in Chapter 11, <i>Parameters</i> . When the value is correct, press ENTER to return to the top line. Press ENTER again. <b>Important:</b> Depending on the option mode that you chose, you are asked specific questions about how you want to set up your L Option board.	Step 6
6.	Make Stop#1 Type COAST Stop? N	Choose how you want your drive to stop. You have three choices: coast, ramp, or current limit. For more information about these stop types, refer to the <i>Speed Reference Selection Overview</i> in Appendix B, <i>Control Block Diagrams</i> . Press ENTER if you do not want to use a coast stop. You will then be prompted for a ramp stop followed by a current limit stop. If you do want to use a coast stop, use INC or DEC to toggle the N to a Y. Press ENTER.	Step 7
7.	Accel Time 1 5.0 SEC	Press SEL. Decide what value you want the drive to use for the acceleration ramp. For more information about the acceleration ramp, refer to the <i>Speed Reference Selection Overview</i> in Appendix B, <i>Control Block Diagrams</i> . Use INC or DEC to enter the value. When the value is correct, press ENTER to return to the top line. Press ENTER again.	Step 8
8.	Decel Time 1 5.0 SEC	Press SEL. Decide what value you want the drive to use for the deceleration ramp. For more information about the deceleration ramp, refer to the <i>Speed Reference Selection Overview</i> in Appendix B, <i>Control Block Diagrams</i> . Use INC or DEC to enter the value. When the value is correct, press ENTER to return to the top line. Press ENTER again.	Step 9

Step:	At this prompt:	You need to:	Go to:
9.	Speed Ref 1 +500.2 RPM	If a speed reference is not already linked, you can enter a value to use as a preset speed. For example, if there is a link to <i>Speed Ref 1</i> (parameter 29), the start up procedure would skip to <i>Speed Ref 2</i> (parameter 31), or the next non-linked speed reference. For each speed reference, press SEL. Use INC or DEC to enter the value. When the value is correct, press ENTER to return to the top line. Press ENTER again.	Step 10
10.	Digital Config. Complete ENTER	Press ENTER.	

## Configuring the Analog Section

Follow these steps to configure the analog section:

Step:	At this prompt:	You need to:	Go to:
1.	Setup Reference Analog/PPR IO? N	Press ENTER if you do not want to configure the analog section.	Step 11
		If yes, press INC or DEC to toggle the N to a Y. Press ENTER.	Step 2
2.	Connect Inputs to References? N	To connect the inputs, press INC or DEC to toggle the N to a Y. Press ENTER to connect inputs to Speed Reference 1, speed Reference 2, Torque Reference, Current, or 4 – 20 mA.	Step 3
		If no, press ENTER.	Step 6
3.	Configure Speed Reference #1? N	Press INC or DEC to toggle the N to a Y to configure Speed Reference 1. Press ENTER. You can connect Speed Reference 1 to any ONE of the following: the HIM pot, Analog In1, Analog In2, the 4 – 20 mA input, the MOP input, the Pulse Input, or the gateway. Depending on which input you choose, you may be prompted for an offset and scale value.	Step 4
		If no, press ENTER.	
4.	Configure Speed Reference #2? N	Press INC or DEC to toggle the N to a Y to configure Speed Reference 2. Press ENTER. You can connect Speed Reference 2 to any ONE of the following: the HIM pot, Analog In1, Analog In2, the 4 – 20 mA input, the MOP input, the Pulse Input, or the gateway. Depending on which input you choose, you may be prompted for additional information.	Step 5
		If no, press ENTER.	
5.	Configure Torque Reference? N	Press INC or DEC to toggle the N to a Y to configure the Torque Reference. Press ENTER. You can connect the Torque Reference to any ONE of the following: the HIM pot, Analog In1, Analog In2, the 4 – 20 mA input, or the gateway. Depending on which input you choose, you may be prompted for an offset and scale value.	Step 6
		If no, press ENTER.	
6.	Configure Analog Outputs? N	Press INC or DEC to toggle the N to a Y to connect the analog outputs. Press ENTER.	Step 7
		If no, press ENTER.	Step 11
7.	Configure Analog Output #1? N	Press INC or DEC to toggle the N to a Y to configure Analog Output 1. Press ENTER. You can connect it to one of the following: Speed, Current, Volts, Torque, or Power. In addition, you are asked for an offset and scale value.	Step 8
		If no, press ENTER.	
8.	Configure Analog Output #2? N	Press INC or DEC to toggle the N to a Y to configure Analog Output 2. Press ENTER. You can connect it to one of the following: Power, Speed, Current, Volts, or Torque. In addition, you are asked for an offset and scale value.	Step 9
		If no, press ENTER.	
9.	Setup the 4 – 20 mA Output? N	Press INC or DEC to toggle the N to a Y to configure the 4 – 20 mA output. press ENTER.	Step 10
		If no, press ENTER.	
10.	Configure HIM Status Display? N	Press INC or DEC to toggle the N to a Y to adjust to output to the HIM display. Press ENTER. You can link to Speed, Current, Volts, Torque, or Power. You are then asked to reset the HIM.	Step 11
		If no, press ENTER.	
11.	Startup Complete Press ENTER	Press ENTER.	

## Understanding Links

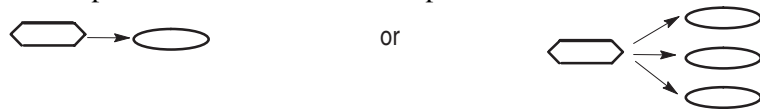
A link is a software connection between two parameters that lets one parameter receive information from another parameter. The parameter receiving the information is called a destination parameter. Throughout this manual, destination parameters are identified by the following symbol:



The parameter providing the information is called a source parameter. Throughout this manual, source parameters are identified by the following symbol:



Each destination parameter can only have one source parameter. However, source parameters may be linked to multiple destination parameters. The information from the link always flows from the source parameter to the destination parameter:



## Creating a Link

You create links at the destination parameter. To create a link:

1. Go to the parameter that you want to receive the information.
2. Enter the number of the source parameter.

The following example uses a Human Interface Module (HIM) to create a link. For this example, *SP An Output* (parameter 139) is the destination parameter that is linked to *Motor Torque %* (parameter 86), which is the source parameter. To create this link:

1. From the *Choose Mode* prompt, use INC or DEC to select *Links*.
2. Press INC or DEC to select *Set Links*. The HIM automatically scrolls through the linear parameter list until it finds a parameter that you can link.
3. Use INC or DEC to scroll through the parameter list until you come to the destination parameter that you want to link. In this example, you would use INC or DEC until you reach parameter 139. The display should be similar to the following:



4. Press SEL. The display should now be similar to the following:



5. Press INC or DEC to go to the parameter that you want to provide the information. In this case, parameter 8 — *Motor Torque %*.
6. Press ENTER.
7. Press ESC when you have finished to exit the *Set Links* mode.

## Using the Pre-Defined Links

The following are the pre-defined links:

	Source		To		Destination
SP An In1 Value	134	→	To	→	29 Speed Ref 1
An In 1 Value	96	→	To	→	31 Speed Ref 2
Motor Speed	81	→	To	→	105 An Out 1 Value
Motor Power	90	→	To	→	108 An Out 2 Value
Motor Speed	81	→	To	→	139 SP An Output

The default configuration assumes that a Human Interface Module (HIM) terminal is connected to SCANport. *Speed Ref 1* is connected to *SP An In1 Value*, which is assumed to be the HIM port.

## Removing a Link

To remove a link, you need to:



**ATTENTION:** Be careful when removing links. If the source parameter has already written a value to the destination parameter, the destination parameter retains the value until you explicitly remove it. For some parameters, this may produce undesirable results.

1. From the *Choose Mode* prompt, use INC or DEC to select *Links*.
2. Press INC or DEC to select *Set Links*.
3. Use INC or DEC to scroll through the parameter list until you come to the destination parameter that you want to link.
4. Press SEL.
5. Enter 0.
6. Press ENTER.
7. Press ESC when you have finished to exit the *Set Links* mode.

## Where Do I Go From Here?

Your drive should now be up and communicating with your terminal device(s). To change the way the drive operates by default, you can modify some of the default settings. You can use the following table as a starting point.

<b>If you want to:</b>	<b>Then refer to:</b>
Use the L Option	Chapter 5
Understand how analog I/O works	Chapter 7
Understand how to use pulse input	Chapter 7
Use the programmable relay	Chapter 7
Modify your SCANport configuration	Chapter 9
Use a communication gateway	Chapter 9
Select a braking method	Chapter 9
Use a remote pot	Chapter 9
Use the MOP	Chapter 9
Use Speed Profiling	Chapter 9
Understand precharge and ridethrough	Chapter 12
Adjust the Kp, Ki, and/or Kf gains	Chapter 13
Understand the auto-tune procedures	Chapter 13
Understand the process trim routine	Appendix B
Understand the speed reference selection process	Appendix B
Understand the NTC and IT protection mechanisms	Appendix B
Learn more about the Human Interface Module (HIM)	Appendix C



## Setting Up the Input/Output

### Chapter Objective

Chapter 7 provides information to help you set up the standard I/O for the 1336 IMPACT drive.

This topic:	Starts on page:
A description of drive units	7-1
Setting up the analog I/O	7-1
Setting up the 4 – 20 mA I/O	7-8
Using the SCANport capabilities	7-10
Configuring the output relays	7-10
Configuring the pulse input	7-11
Configuring the L option I/O	7-12

### What Are Drive Units?

The drive uses internal drive units to represent input and output values. Each parameter is a 16-bit word that allows a range of  $\pm 32767$  or 65535 internal units. The drive is scaled so that 4096 is equal to one per unit or 100% of the quantity being regulated. For analog inputs, 5V converts to a digital value of 1024. Therefore, if you have a  $\pm 10V$  DC signal, you have a total range of  $\pm 2048$  internal drive units. For the analog outputs, 1024 converts to an analog output voltage of 5V.

### Setting Up the Analog I/O

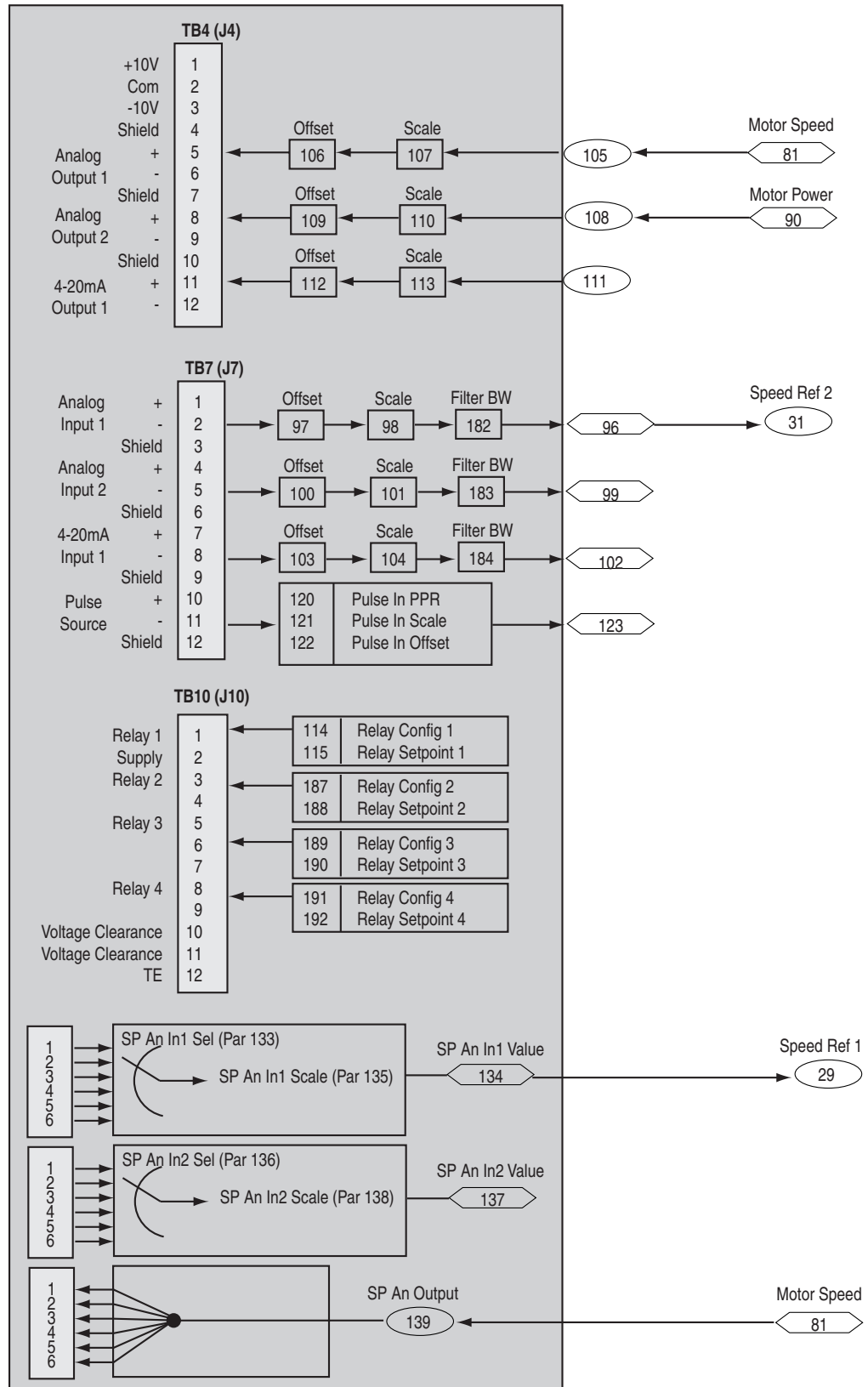
Before you can use analog I/O, you need to do the following:

1. Hard wire the analog I/O to the board terminals. This is covered in the mounting and wiring chapter.
2. Set up the analog input and output configuration parameters in the drive. This can be performed during the start up sequence.
3. Create any user links, if appropriate.

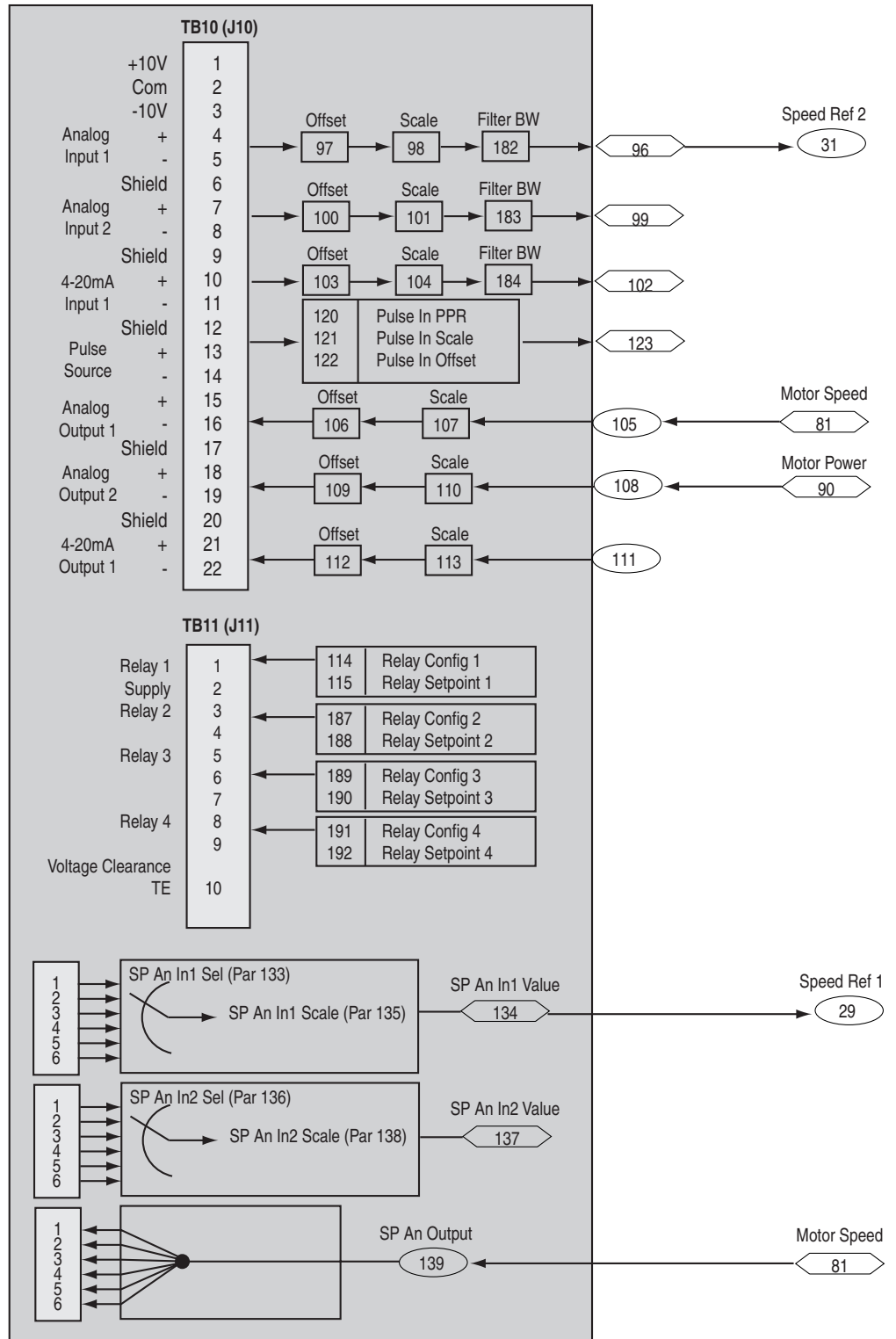
► *The 1336 IMPACT drive has been pre-configured for your convenience. Refer to Chapter 6, Starting Up Your System, for a complete list of the pre-defined links.*

Each terminal has parameters associated with it as shown in Figures 7.1 and 7.2.

**Figure 7.1**  
**Parameters with Associated Terminals for Frames A1 – A4**



**Figure 7.2**  
Parameters with Associated Terminals for Frames B – H



As Figures 7.1 and 7.2 show, each analog input and output parameter has associated offset and scale parameters. The 1336 IMPACT drive provides the offset and scale parameters so that you can adjust the range of the analog input and output sources and use the entire internal range of drive units.

► *If you are having problems determining your scale and offset values or are using a PLC, refer to the explanation in the application section.*

The following table provides information about the analog scale and offset parameters.

	Input Range	Output Range	Affects	Description
Offset parameters (97, 100, 103, 106, 109, and 112)	±20	±20	analog value (external units)	Lets you shift the input range. For example, if your analog input values have a range of 0 to 10V, you can use an offset value of -5 to change the range to ±5V.
Scale parameters (98, 101, 104, 107, 110, and 113)	±16	±1	digital value (internal units)	Lets you use the full range of internal drive units. The maximum range is ±32767 internal units. The maximum analog to digital value is ±2048.
Filter parameters (182, 183, and 184)	0 – 200	NA	digital value (internal units)	Lets you use a low pass filter to reduce the noise received from the input.

► *Not all applications require both an offset parameter and a scale parameter. For example, if you have an input range of 0 to 10V and you want a range of 0 to 8192 internal drive units, you do not need to supply an offset value. If you do not require an offset value, make sure that the offset parameter is set to 0. Likewise, you may not need a scale value. If this is the case, make sure that the scale parameter is set to 1.*

### Determining the Offset and Scale Values for an Analog Input

*file:* Interface/Comm  
*group:* Analog Inputs

To determine the offset and scale values for an analog input, you need to know the following:

- the range of units coming from the analog input (for example, -5V to +5V or 0V to 10V)
- the range that you want to see in internal drive units (for example, -2048 to +2048 or 0 to 4096)

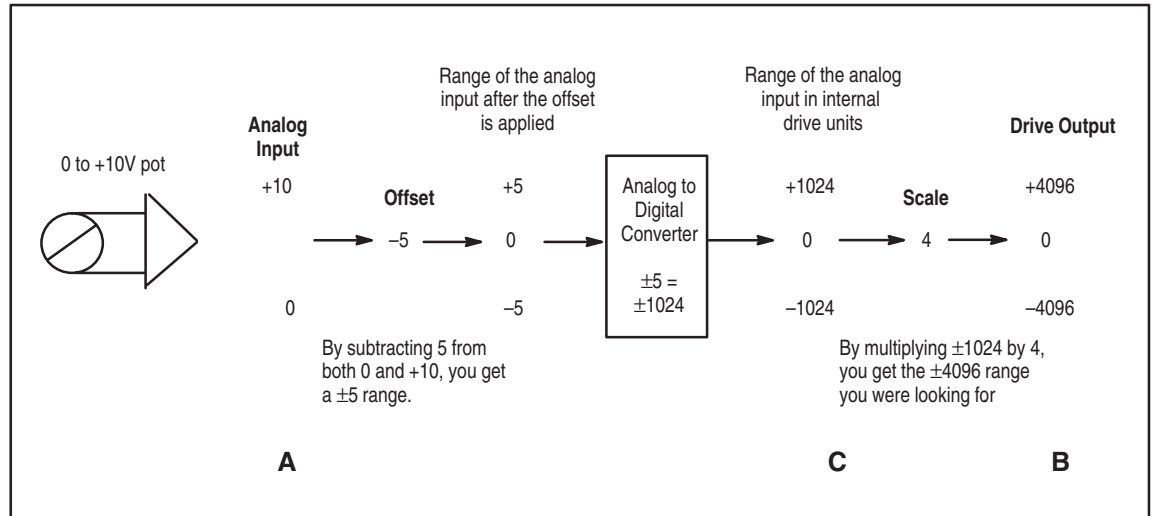
You determine the value of the offset parameter by comparing the range of units coming from the analog input to the range that you want to see in internal drive units. For example, if you need to get a ± drive unit range from a 0 to 10V input range, you can use an offset of -5 (subtracting 5 from both 0 and 10 gives you a -5 to +5 range).

Once you have the proper range, the offset is converted to an internal, or digital, value. 10V is always equal to 2048 internal drive units. 5V equals 1024 internal drive units. For this example, the internal drive units are ±1024.

To get to the desired range of  $\pm 4096$  ( $4096 = \text{base motor speed}$ ), you need to scale the internal drive units by 4 ( $4 \times 1024 = 4096$ ).

Figure 7.3 shows an example of the offset and scale values for an analog input parameter.

**Figure 7.3**  
**Example of Offset and Scale for Analog Inputs**



To summarize, to determine the offset and scale values for your analog inputs, you need to:

1. Compare the output range to the internal drive unit range. In the example shown in Figure 7.3, you would compare the ranges represented by A and B.

If the ranges are:	Then you:	Go to:
The same (that is, both $\pm$ , both 0 to +n, or both 0 to -n)	Do not need an offset	Step 3
Different	Need an offset	Step 2

In the example shown in Figure 7.3, the ranges were different, so we used Step 2.

2. Calculate the offset. For example, if you need a 0 to +10V input and you have a  $\pm 4096$  internal range, offset the 0 to +10V range to get a  $\pm$  range. In this case, an offset of -5 works because subtracting 5 from both 0 and 10 gives you a -5 to +5 range.
3. Convert the analog input range to a digital range based on 10V being equal to 2048. For example:

This analog value:	Is converted to this digital value:
+10	+2048
+5	+1024
0	0
-5	-1024
-10	-2048

4. Compare the output of the digital-to-analog conversion (**C**) with the internal drive units (**B**).

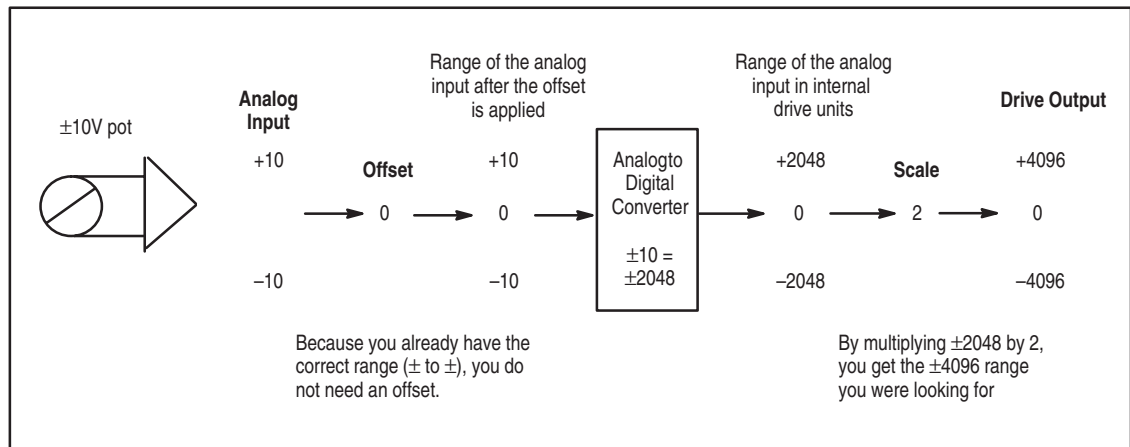
If the values are:	Then you:	Go to:
Identical	Do not need to scale the value	Step 6
Different	Need to scale the value	Step 5

In Figure 7.3, the values were different, so we used Step 5.

5. Calculate the scale. For example, if the output of the digital to analog conversion is  $\pm 1024$  and the internal drive units are  $\pm 4096$ , the scale value should be 4 ( $4 \times 1024 = 4096$ ).
6. Enter the offset and scale values into the appropriate parameters.

Figure 7.4 shows another example of an analog input. In this example, you have an analog input range of  $\pm 10V$  and you want an internal range of  $\pm 4096$  ( $4096 = \text{base motor speed}$ ).

**Figure 7.4**  
**Example of Offset and Scale for Analog Inputs**



The offset is  $0$  because the analog input and the internal range are both  $\pm$  ranges. When the  $\pm 10V$  range is converted to internal units, you get a range of  $\pm 2048$ . To get the internal range of  $\pm 4096$ , you can use a scale factor of  $2$  ( $2 \times 2048 = 4096$ ).

The 1336 IMPACT drive provides analog input filter parameters for you to use if the analog values are unstable. The filter parameters use a low pass filter to create a more stable value. You will lose some of the available bandwidth by using these parameters.

### Determining the Offset and Scale Values for an Analog Output

To determine the offset and scale values for an analog output, you need to know the following:

- the range that you want for the analog output (for example,  $-5V$  to  $+5V$  or  $0V$  to  $10V$ )
- the range that the drive is using for the internal units (for example,  $-2048$  to  $+2048$  or  $0$  to  $4096$ )

*file:* Interface/Comm  
*group:* Analog Outputs

Determining the offset and scale parameters for analog outputs can be confusing. You need to calculate the offset before you can calculate the scale. However, because the drive applies the scale first and then the offset, you need to take the inverse of your results. For example, if you calculated a scale factor of 2 and you were trying to convert from  $\pm 4096$  drive units to a  $\pm 10V$  output, you would actually want to use a scale factor of  $1/2$ , or  $0.5$ .

Figure 7.5 shows an example of the scale and offset values for an analog output parameter.

**Figure 7.5**  
**Example of Scale and Offset for Analog Outputs**

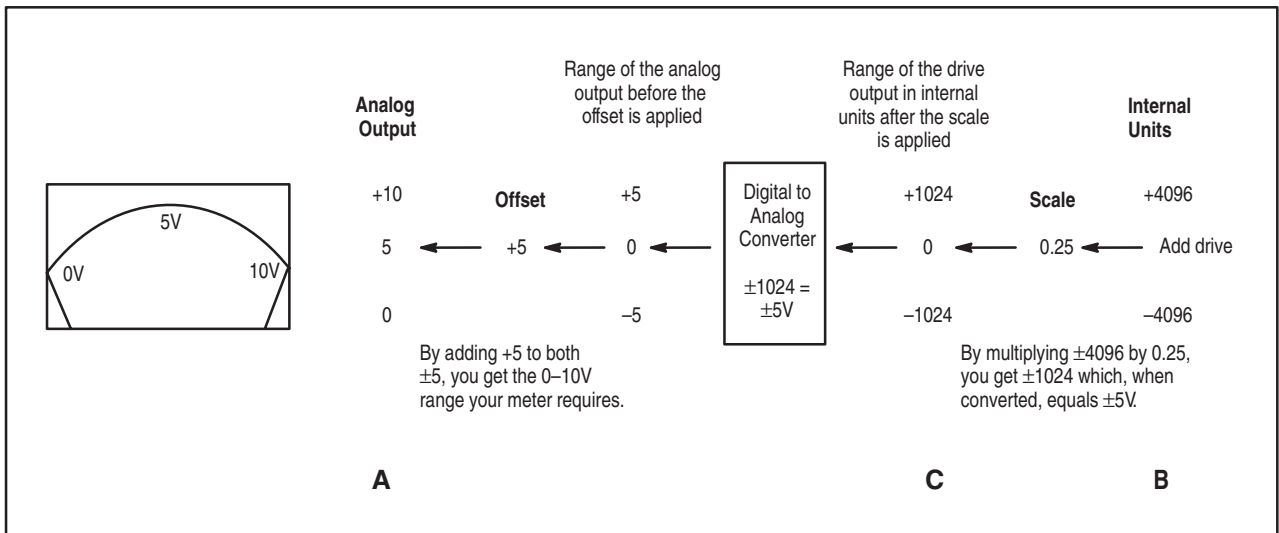


Figure 7.5 is used to help explain the offset and scale values for analog output. To determine the offset and scale values, you need to:

1. Compare the output range to the internal units range. In the example shown in Figure 7.5, you would compare the ranges represented by **A** and **B**.

If the ranges are:	Then you:	Go to:
The same (that is, both $\pm$ , both 0 to +n, or both 0 to -n)	Do not need an offset	Step 4
Different	Need an offset	Step 2

In the example shown in Figure 7.5, the ranges were different so we used Step 2.

2. Calculate the offset. For example, if you need a 0 to +10V input and you have a  $\pm 4096$  internal range, you need to offset the 0 to +10V range to get a  $\pm$  range. In this case, you would have an offset of -5.
3. Take the opposite sign of what your offset calculations show. In this case, the true offset would be +5. Therefore, when +5 is added to the range values after the range is converted to an analog value, the range comes out to 0 to 10V.

4. Convert the digital output range to an analog range. For example:

This digital value:	Is converted to this analog value:
+2048	+10
+1024	+5
0	0
-1024	-5
-2048	-10

5. Compare the input to the digital-to-analog conversion (C) with the internal drive units (B).

If the values are:	Then you:	Go to:
Identical	Do not need to scale the value	Step 8
Different	Need to scale the value	Step 6

In Figure 7.5, the values were different so we used Step 6.

6. Calculate the scale. For example, if the input to the digital to analog conversion is  $\pm 1024$  and the internal drive units are  $\pm 4096$ , the scale value should be 4 ( $4 \times 1024 = 4096$ ).
7. Take the inverse of the value you calculated in Step 6. For example, if the scale value should be 4, you need to actually use  $1/4$ , or 0.25 as your scale value.
8. Enter the offset and scale values into the appropriate parameters.

## Setting Up the 4 – 20 mA Input/Output

When setting up the 4 – 20 mA input/output, you should keep the following in mind:

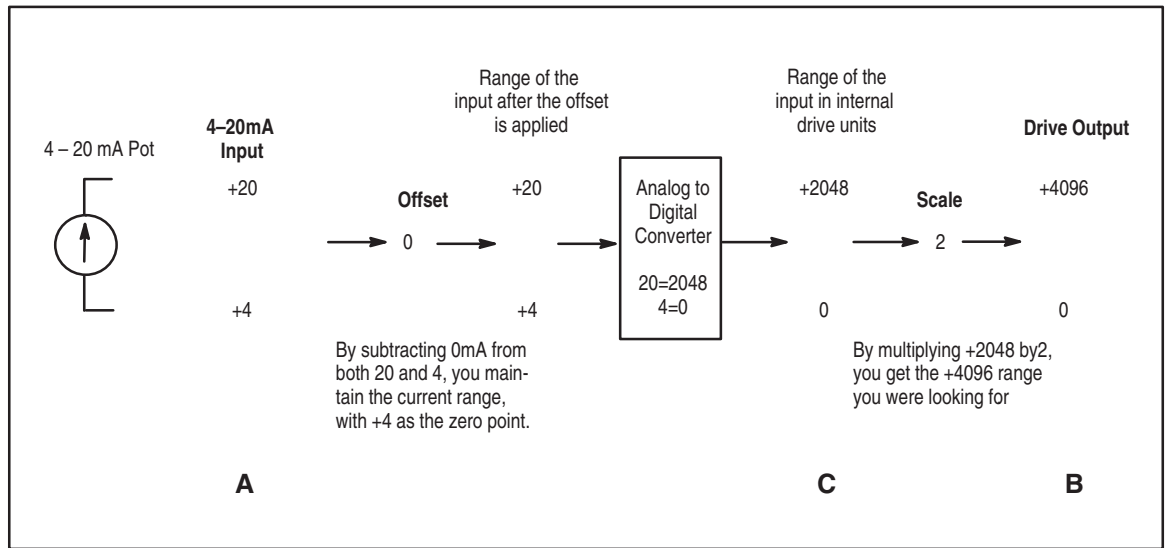
- 4 – 20 mA I/O is not bi-directional.
- 4 – 20 mA faults occur when the 4 – 20 mA input is connected to a current source and then removed. This trip point is -250 drive units or 0.45 mA.
- The maximum number of drives on the mA output is 3.
- The 4 – 20 mA output can drive a maximum load of  $750\Omega$ .

When setting up your 4 – 20 mA input/output, you need to know that 4 mA is equal to 0 internal units and 20 mA is equal to 2048 internal units.

The scaling and offset parameters for 4 – 20 mA input/output work similarly to the analog scaling and offset parameters. Figure 7.6 shows an example of the scaling and offset used for the 4 – 20 mA input.



**Figure 7.6**  
**Example of Scaling and Offset for 4 – 20 mA Inputs**



In this example, the 4 – 20 mA input is offset and scaled to provide  $\pm 2048$  range from the 4 – 20 mA input. To do this, you would need to:

1. Compare the range of the output that you want to 4 – 20.

If the ranges are:	Then you:	Go to:
The same (that is, both positive)	Do not need an offset	Step 3
Different	Need an offset	Step 2

In the example shown in Figure 7.6, the ranges were the same, so we used Step 3.

2. Calculate the offset.
3. Convert the mA range to a digital range, if you have not already done so. Keep in mind that 20 mA equals 2048 and 4 mA equals 0.
4. Compare the output of the conversion to internal units to the output range you want.

If the values are:	Then you:	Go to:
Identical	Do not need to scale the value	Step 6
Different	Need to scale the value	Step 5

In the example shown in Figure 7.6, the ranges were different, so we used Step 5.

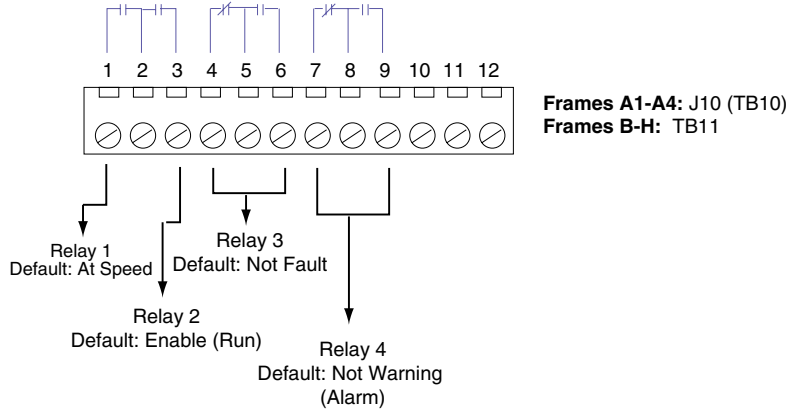
5. Calculate the scale. In this example, the internal units were +2048 and you needed 4096; therefore, you would use a scale value of 2.
6. Enter the offset and scale values into the appropriate parameters.

## Using the SCANport Capabilities

To communicate with external devices such as terminals, the 1336 IMPACT drive uses the SCANport communications protocol. You can access the SCANport capabilities without doing any special configuration. However, if you plan to use SCANport, you can change the default configuration to customize the way SCANport works for you. Chapter 8, *Using the SCANport Capabilities*, contains information about SCANport and how you can change the default configuration.

## Configuring the Output Relay

There are four programmable relays:



*file:* Interface/Comm  
*group:* Digital Config

This relay:	Is configured using these parameters:	And defaults to the following:
1	<i>Relay Config 1</i> (parameter 114) and <i>Relay Setpoint 1</i> (parameter 115)	At Speed
2	<i>Relay Config 2</i> (parameter 187) and <i>Relay Setpoint 2</i> (parameter 188)	Enable
3	<i>Relay Config 3</i> (parameter 189) and <i>Relay Setpoint 3</i> (parameter 190)	Not Fault
4	<i>Relay Config 4</i> (parameter 191) and <i>Relay Setpoint 4</i> (parameter 192)	Not Warning (alarm)

The programmable relays are a combination of normally open and closed contacts. You can configure these relays using the *Relay Config x* parameters to specify that a relay should follow a specific function. You can configure the relay to follow the bit function or the NOT of the function. For example:

If the motor is at set speed and you want the contact to:	You would enter this value in the <i>Relay Config</i> parameter:
Close	13 to indicate At Set Speed
Open	14 to indicate Not At Set Speed

Refer to the descriptions of *Relay Config 1*, *Relay Config 2*, *Relay Config 3*, or *Relay Config 4* in Chapter 11, *Parameters*, for a complete listing of functions.

## Configuring the Pulse Input

*file:* Interface/Comm  
*group:* Digital Config

The pulse input lets an external source provide the drive with a digital reference or trim signal. Pulse input is a differential input with a maximum frequency of 100kHz. The parameters available for pulse input include:

To:	Use this parameter:
Set the number of pulses per one revolution	<i>Pulse In PPR</i> (parameter 120)
Apply a scale to the external source	<i>Pulse In Scale</i> (parameter 121)
Add or subtract a fixed amount to or from <i>Pulse In Value</i>	<i>Pulse In Offset</i> (parameter 122)
View the pulse input value	<i>Pulse In Value</i> (parameter 123)

By using the pulse input, you can have an external source provide the drive with a digital reference or trim signal. This can be useful if you have a system with multiple drives and you want encoder magnetic pickup or a lead drive that provides a pulse to supply the reference for any secondary drives, called follower drives. You could use this reference to ensure that all drives run at the same speed or to ensure that the speed of the follower drives is related to the speed of the reference.

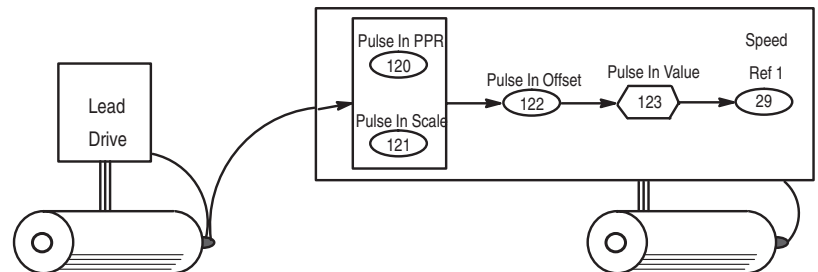
Basically, the drive performs the following functions:

1. Uses the values that you enter into *Pulse In PPR* and *Pulse In Scale* to perform some calculations. *Pulse In Scale* can be any value from 0.01 to 10.00.
2. Applies the *Pulse In Offset* value.
3. Places the result in *Pulse In Value*.

The drive can use the value placed in *Pulse In Value* to, for example, control the speed of a second motor.

For example, you could have a system with two drives. The lead drive has a 1024 PPR encoder with a base speed of 1750 rpm. For this application, the second drive, or follower, uses the lead drive's encoder, but the application needs the follower to run at half the speed of the lead drive.

**Figure 7.7**  
**Pulse Input Configuration**



To set up the follower drive, you would need to:

1. Set *Pulse In PPR* (parameter 120) to 1024.
2. Set *Pulse In Scale* (parameter 121) to 0.50.

3. Set *Pulse In Offset* (parameter 122) to 0.
4. Create a link from *Speed Ref 1* (parameter 29) to *Pulse In Value* (parameter 123).

## Configuring the L Option I/O

<i>file:</i> Interface/Comm <i>group:</i> Digital Config
---

The L Option input modes configure the L Option inputs. Chapter 5, *Using the L Option*, describes the input modes. The modes let you set up the input to meet the requirements of your application. *L Option Mode* (parameter 116) sets the mode and takes effect on a power cycle or reset.

▶ *The stop type available in modes 3, 13, and 16 only affects the L Option stop input. Two-wire run forward and run reverse use Stop Type 1 when the circuit is opened. SCANport devices use Stop Type 1. The stop types are set up in Logic Options (parameter 17).*

<i>file:</i> Control <i>group:</i> Accel/Decel
---

*Accel Time 1* (parameter 42) and *Accel Time 2* (parameter 43) and *Decel Time 1* (parameter 44) and *Decel Time 2* (parameter 45) are selected by modes 4, 11, and 14. Otherwise, the acceleration/ deceleration times follow *Accel Time 1* and *Decel Time 1*.

▶ *If the L Option mode is not 1, the L Option speed reference takes ownership of the speed reference. To let other devices control speed reference, disable the L Option speed reference with Dir/Ref Mask (parameter 124) for modes 4 – 7, 10, 11, 14 – 25, or set Speed Ref 1, 2, and 3 – 7 for modes 2, 3, 8, 9, 12, and 13. If you select modes 19, 20, or 22, the L Option board takes precedence over Spd/Trq Mode Sel (parameter 68).*

## Configuring the Manually Operated Potentiometer (MOP) Function

<i>file:</i> Interface/Comm <i>group:</i> Digital Config
---

The L Option I/O, modes 5, 9, and 15, control the Manually Operated Potentiometer (MOP) function. The MOP up and MOP down, increment and decrement *MOP Value* (parameter 118) based on *MOP Increment* (parameter 117), which is in rpm per second. To control speed, you need to link *MOP Value* to a speed reference.

## Using the SCANport Capabilities

### Chapter Objectives

Chapter 8 provides information for changing the default configuration to customize the way SCANport works for you.

This topic:	Starts on page:
Understanding the <i>Logic Input Sts</i> parameter	8-1
Configuring the SCANport controls	8-3
Setting the SCANport faults	8-7
Using the SCANport I/O image	8-8
Setting the analog I/O parameters	8-14

### Understanding the Logic Input Sts Parameter

*file:* Monitor  
*group:* Drive/Inv Status

*Logic Input Sts* (parameter 14) shows which functions are currently executing. To use SCANport effectively, you need to understand how *Logic Input Sts* works.

*Logic Input Sts* has the following bits:

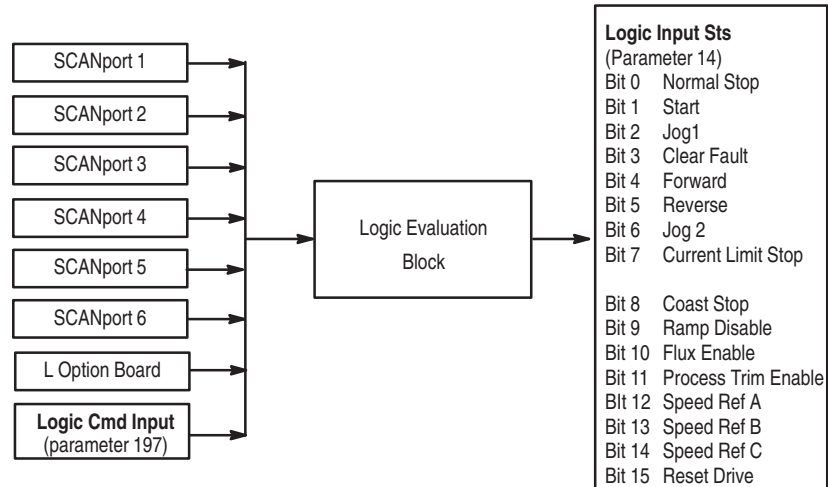
This bit:	Identifies this function:	This bit:	Identifies this function:
0	Normal Stop	8	Coast Stop
1	Start	9	Ramp Disable
2	Jog1	10	Flux Enable
3	Clear Fault	11	Process Trim Enable
4	Forward	12	Speed Ref A
5	Reverse	13	Speed Ref B
6	Jog2	14	Speed Ref C
7	Current Limit Stop	15	Reset Drive

### SCANport Definition

Serial Communications devices such as the Human Interface Module that are directly mounted on the IMPACT drive are identified as SCANport Device 1. Remote communication devices such as a HIM, GPT etc. are identified as Device 2 and up (depending on the amount of control devices connected to the Drive).

The logic evaluation block receives SCANport control from up to eight sources. The logic evaluation block takes this information and combines it to form a single logic command word that you can view using *Logic Input Sts*. In this manner, the logic evaluation block allows for multi-point control. Figure 8.1 shows the flow of information.

**Figure 8.1**  
**SCANport Interactions with Logic Input Sts**

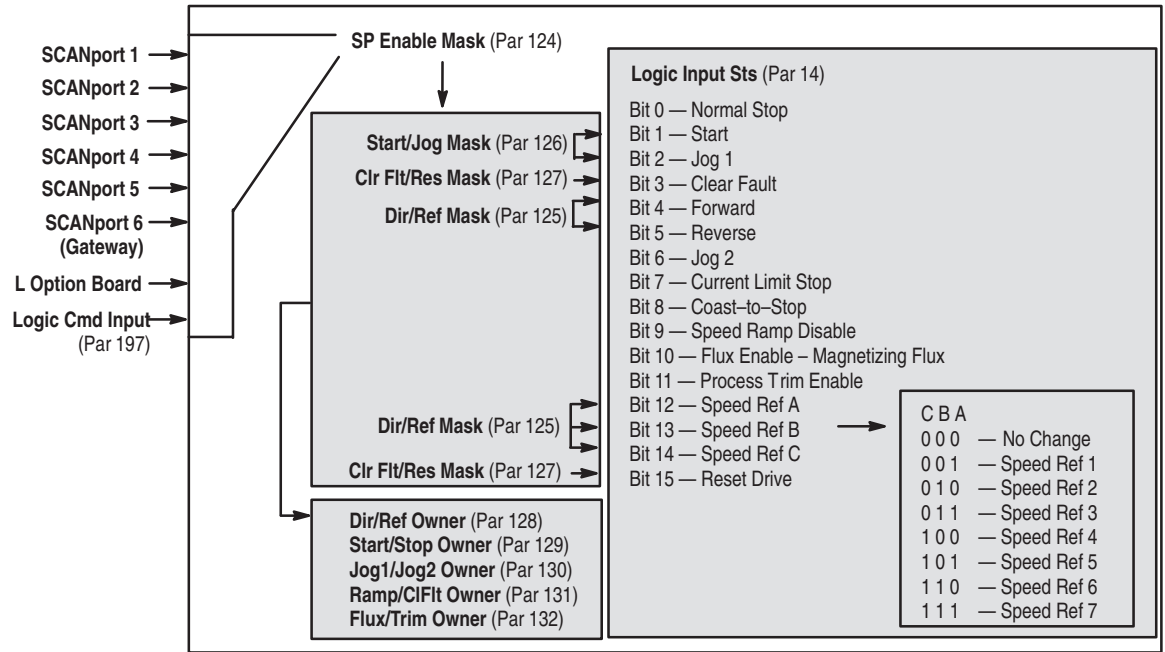


You can attach any combination of Human Interface Modules (HIMs), Graphic Programming Terminals (GPTs), and/or SCANport gateway communications modules to any of the six SCANports. In addition, you can use *Logic Cmd Input* (parameter 197). *Logic Cmd Input* has the same bit definitions as *Logic Input Sts*.

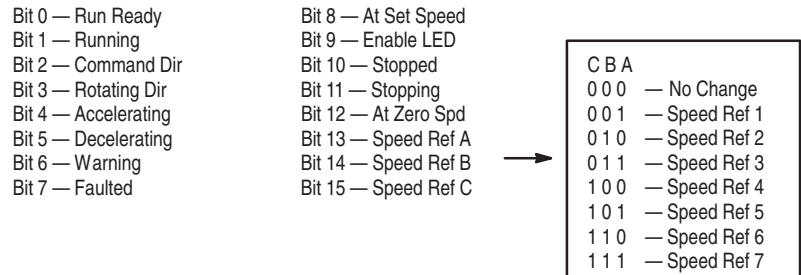
You can access ports 1 and 2 on frames A1 – A4 and ports 1, 2, and 6 on frames B – H directly from the main control board. To access ports 3, 4, and 5, you need to plug a Port Expander into port 2. Normally, port 1 is connected to a HIM, and port 6 is used for connecting to gateways.

Figure 8.2 shows the parameter interactions involved with *Logic Input Sts*.

**Figure 8.2**  
**Parameter Interactions**



**Drive/Inv Status (Par 15)**



The owner parameters (128 through 132) are covered in the next section.

**Configuring the SCANport Controls**

SCANport has two parts: control and analog I/O. The SCANport controls are the functions that control the motor, such as start, stop, and jog. The control can come from up to six SCANport devices, *Logic Cmd Input* (parameter 197), and one L Option Board simultaneously. The control is based on an ownership mechanism that lets certain functions have only one owner and other functions to have multiple owners.

Control of these functions can come from only one device:	Any device can control these functions:	
Speed reference	Start	Stop
Direction	Jog	Clear fault
Local	Reset drive	Flux enable
	Speed ramp disable	Process trim enable

Ownership is when a SCANport device commands a function. As long as that function is commanded, that device is the owner of that function. For example, if device 1 is commanding a forward direction, which is a one owner function, no other device can change the direction until device 1 stops commanding the forward direction. If device 1 is sending a start command, which is a multiple owner function, other devices can also command a start. If device 1 stops commanding the start, the drive does not stop running if another device is still commanding the start.

► *A rising edge is required for start and jog functions. If a jog or start is still commanded after the drive is stopped, start and jog functions will not operate from any device until the jog or start commands are removed.*

By default, start commands from SCANport devices are 3-wire (latched). If you want a SCANport device to use a 2-wire start (unlatched), you need to set the appropriate bit in *SP 2 Wire Enable* (parameter 181).

To use a 2-wire start for:	Set this bit:
SCANport device 1	1
SCANport device 2	2
SCANport device 3	3
SCANport device 4	4
SCANport device 5	5
SCANport device 6	6
<i>Logic Cmd Input</i> (parameter 197)	7

### Notes Regarding 2 and 3-Wire Operation

When using 3-wire operation:

- Start is momentary (latched).
- A low to high transition on the start input is required to start the drive.
- All 2/3-wire start inputs must be low before a low to high transition will start the drive.
- Stop input unlatches and stops the drive.
- To make 3-wire starts operate like a 2-wire start, you need to wire — OR the start and stop inputs.
- The drive will not start if the stop input is open, the enable input is open, or the drive is faulted. Use *Drive/Inv Status* (parameter 15) bit 0, Run Ready, to know when the drive is ready to start.

When using 2-wire operation:

- Run Fwd/Rev is maintained (unlatched).
- A low to high transition on either Run Fwd/Rev input is required to start the drive.



- All 2/3-wire start inputs must be low before a low to high transition will start the drive.
- Closing both Run Fwd and Rev will start the drive in the last direction it was running.
- Opening all Run Fwd/Rev inputs stops the drive. If any of the Run Fwd/Rev inputs are closed, the drive continues to run. To stop the drive when any Run Fwd/Rev input is opened requires the stop input to be wire ORed with the Run Fwd or Run Rev.
- Stop input stops the drive.
- The drive will not start if the stop input is open, the enable input is open, or the drive is faulted. Use *Drive/Inv Status* (parameter 15) bit 0, Run Ready, to know when the drive is ready to start.

When using a combination of 2- and 3-wire:

- Each wiring type operates as above.
- 2-wire has priority over 3-wire, so opening or closing and opening 2-wire Run Fwd/Rev input will stop the drive even if started by a 3-wire start.
- Stop input stops the drive.

### Determining Function Ownership

To determine which device is issuing a specific command, use parameters 128 through 132:

*file:* Interface/Comm  
*group:* SCANport Status

To determine which device is issuing this command:	Check the high (bits 8 – 15)/ low (bits 0 – 7) byte:	Of this parameter:
Stop	Low	129
Direction control	High	128
Start	High	129
Jog1	High	130
Jog2	Low	130
Speed reference	Low	128
Flux enable	High	132
Trim enable	Low	132
Ramp	High	131
Clear fault	Low	131

For each of these parameters, each bit represents a device:

If this bit is set (for low):	Or if this bit is set (for high):	Then, the owner is:
0	8	L Option
1	9	SCANport device 1
2	10	SCANport device 2
3	11	SCANport device 3
4	12	SCANport device 4
5	13	SCANport device 5
6	14	SCANport device 6
7	15	Logic Cmd Input (parameter 197)



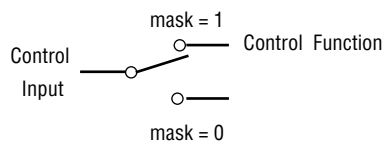
The SCANport device number is determined by the SCANport connection it is plugged into.

### Masking Control Functions

You can also mask control functions. This lets you enable or disable a control function for all or some of the devices.

**Important:** You cannot mask the stop command. Any device attached to the 1336 IMPACT drive can stop the drive at any time.

To set a mask for a control function, you can use the following parameters:



*file:* Interface/Comm  
*group:* SCANport Config

To set a mask to control this function:	Set the appropriate bit in the high/low byte:	Use this parameter:
Control which ports can accept the control functions		124
Issue forward/reverse commands	High	125
Issue a start command	High	126
Issue a jog command	Low	126
Select an alternate reference or preset speed	Low	125
Generate a clear fault command	High	127
Reset drive	Low	127

For each of these parameters, each bit represents a device:

This bit (for low):	Or this bit (for high):	Represents:
0	8	L Option
1	9	SCANport device 1
2	10	SCANport device 2
3	11	SCANport device 3
4	12	SCANport device 4
5	13	SCANport device 5
6	14	SCANport device 6
7	15	Logic Cmd Input (parameter 197)

- The SCANport device number is determined by the SCANport connection it is plugged into.

For a mask parameter:

If a bit is:	Then the control function is:
Clear (0)	Disabled
Set (1)	Enabled

## Setting the SCANport Faults

You can specify how you want to be notified if SCANport loss or communication errors occur.

### Setting the Loss of Communications Fault

You can specify how you want to be notified if SCANport loses the connection to a port.

If you want a communications loss to be:	Then:
Reported as a fault	Set the appropriate bit in <i>Fault Select 1</i> (parameter 20) corresponding to the SCANport device number.
Reported as a warning	Set the appropriate bit in <i>Warning Select 1</i> (parameter 21) and clear the bit in <i>Fault Select 1</i> .
Ignored	Clear the appropriate bit in both <i>Fault Select 1</i> and <i>Warning Select 1</i> .

The following table shows which bits correspond to which ports:

To specify this device:	Set this bit:
SCANport device 1	9
SCANport device 2	10
SCANport device 3	11
SCANport device 4	12
SCANport device 5	13
SCANport device 6	14

For example, if you want a fault condition to be reported if communication is lost with device 3, you would set bit 11 of *Fault Select 1*.



**ATTENTION:** Hazard of personal injury or equipment damage exist. If you initiate a command to start motor rotation (command a start or jog) and then disconnect the programming device, the drive will not fault if you have the SCANport communications fault set to be ignored for that port.

### Setting the SCANport Errors Fault

You can specify how you want to be notified if the SCANport network receives too many errors to continue working properly.

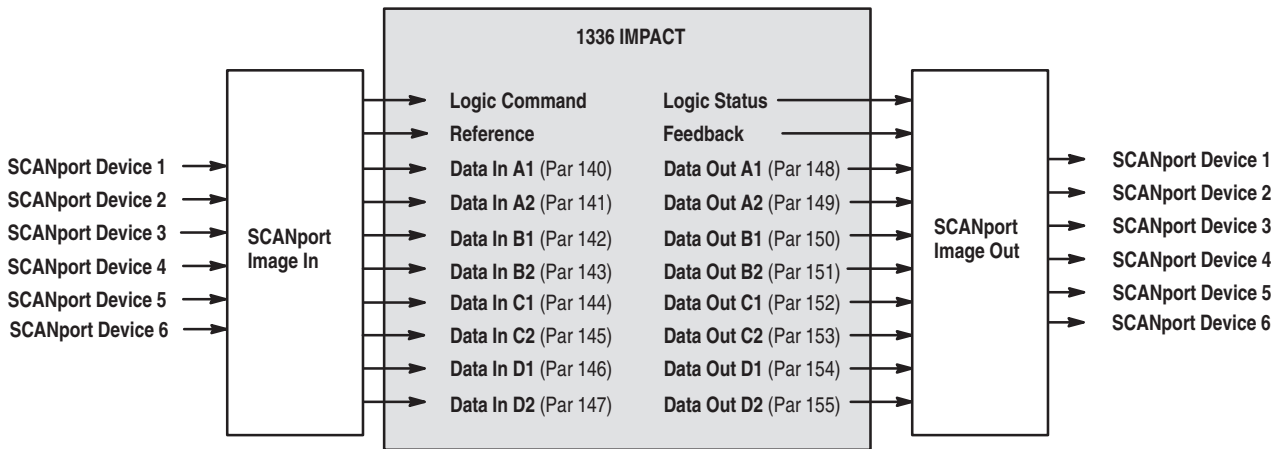
If you want this condition to be:	Then:
Reported as a fault	Set bit 15 in <i>Fault Select 1</i> (parameter 20) corresponding to the SCANport device number.
Reported as a warning	Set bit 15 in <i>Warning Select 1</i> (parameter 21) and clear the bit in <i>Fault Select 1</i> .
Ignored	Clear bit 15 in both <i>Fault Select 1</i> and <i>Warning Select 1</i> .

### Using the SCANport I/O Image

*file:* Interface/Comm  
*group:* Gateway Data In & Gateway Data Out

The SCANport I/O image provides the interface between SCANport devices and the drive. The SCANport I/O image is used to transfer realtime data in the same way as the PLC image is used. The devices on SCANport allocate the SCANport I/O image so multiple devices can use different sections of the image.

To view the values in the I/O image table, use parameters 140 through 147 for input and 148 through 155 for output:



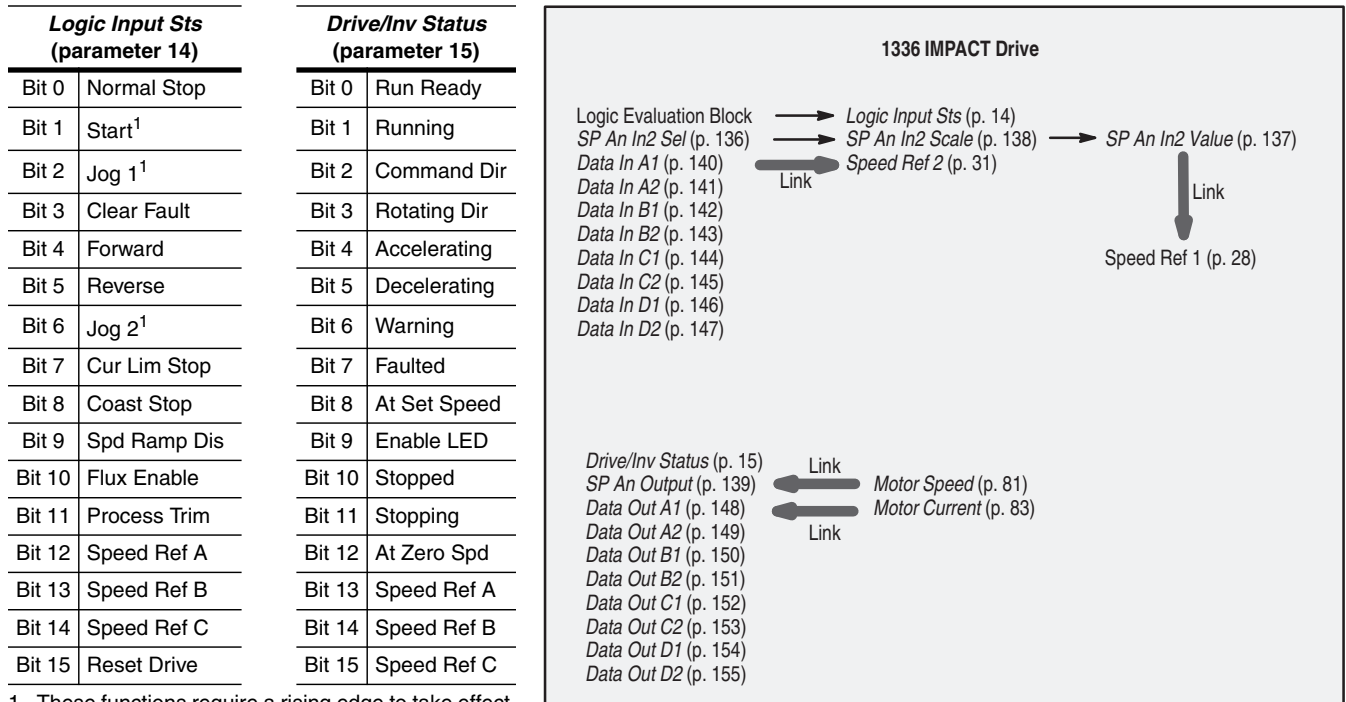
You need to link the Data In parameters (parameters 140 – 147) to other drive parameters.

SCANport gateways or adapters to RIO, serial, DeviceNet, SLC, and Flex I/O are some of the devices that can transfer data between the SCANport I/O image and another device.



*Refer to the appropriate manual for your specific adapter.*

Within the 1336 IMPACT drive, the I/O image table resembles the following:

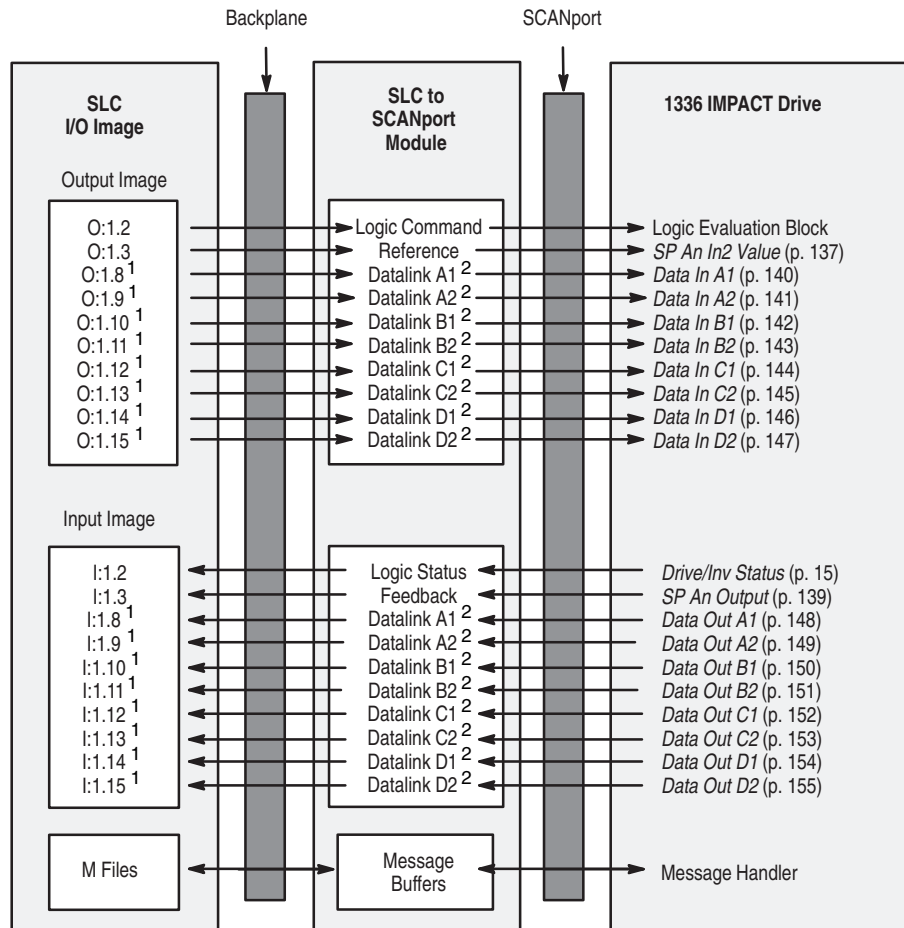


You need to make the links that are shown in order to get the I/O image table data sent to and from the specific parameters within the drive.

The following examples are provided to show how the 1336 IMPACT drive interfaces with some of the available adapters. These are only examples. You should still refer to the appropriate manual for your gateway for additional information.

### SLC to SCANport Module

The following figure shows how the I/O image table for the SLC programmable controller relates to the 1336 IMPACT drive. In this example, the drive is connected to channel 1 of the SLC module in enhanced mode. If this were an example of basic mode, only the O:1.2, O:1.3, I:1.2, and I:1.3 entries would be used.

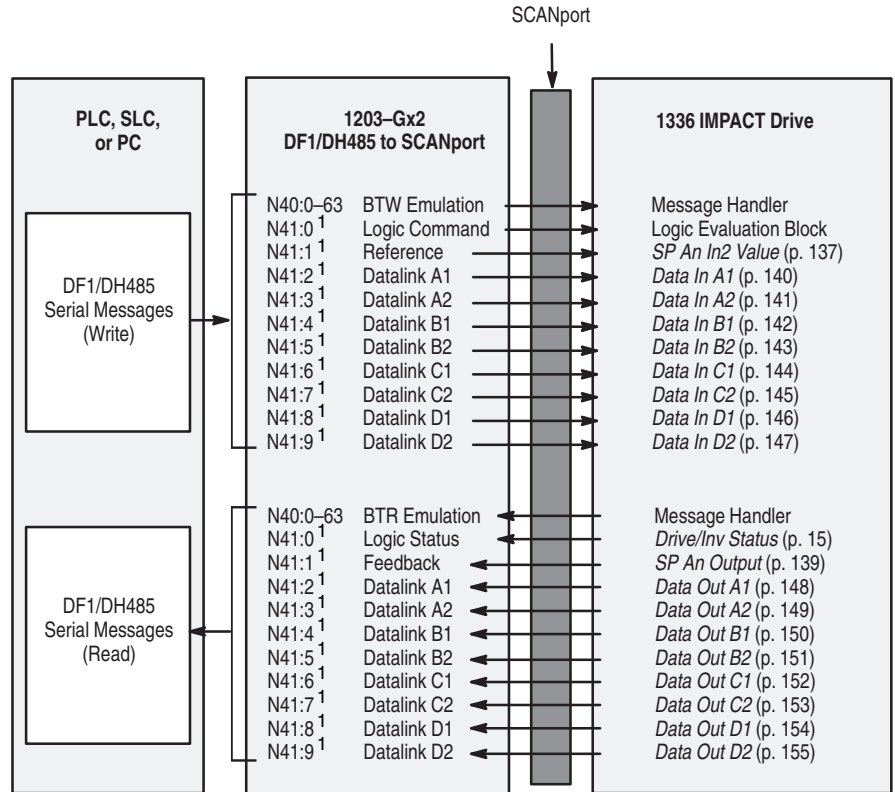


1 Available only in enhanced mode.

2 Optionally enabled via the G file in the SLC processor.

## Serial Communications Module

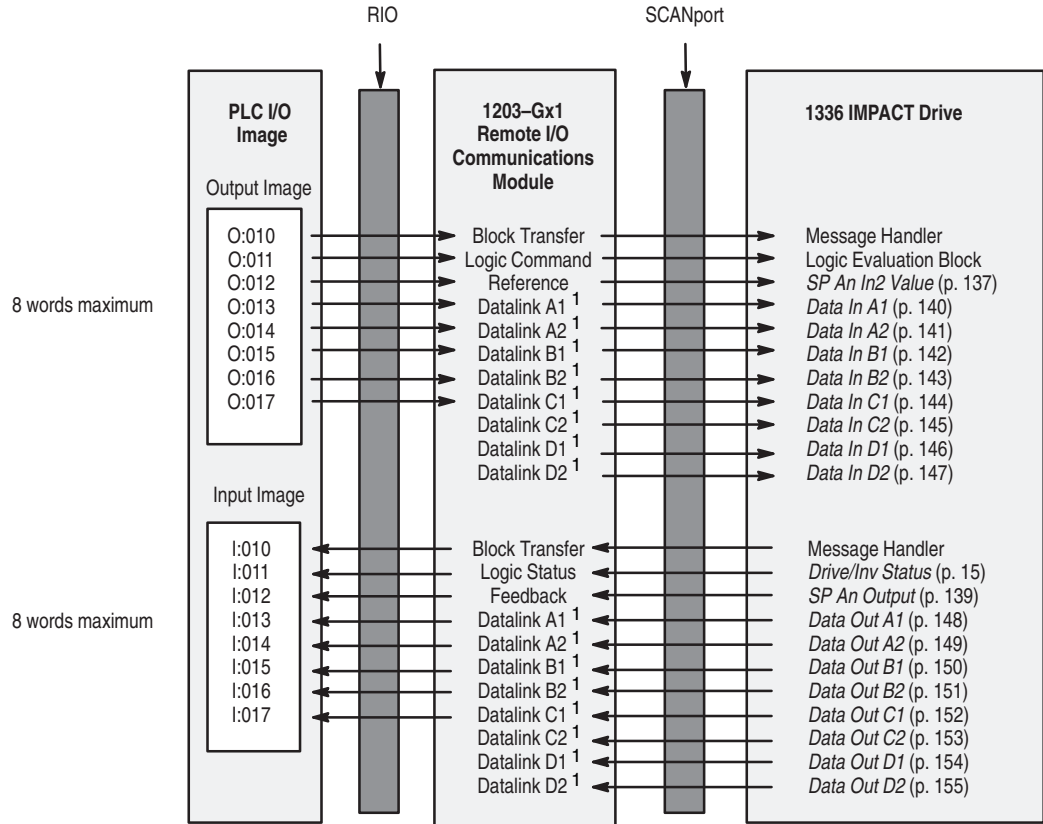
The following figure shows how the I/O image table for the programmable controller relates to the 1336 IMPACT drive when a Serial Communications Module is used.



1 Optionally enabled using DIP switches on the adapter.

### Remote I/O Communications Module

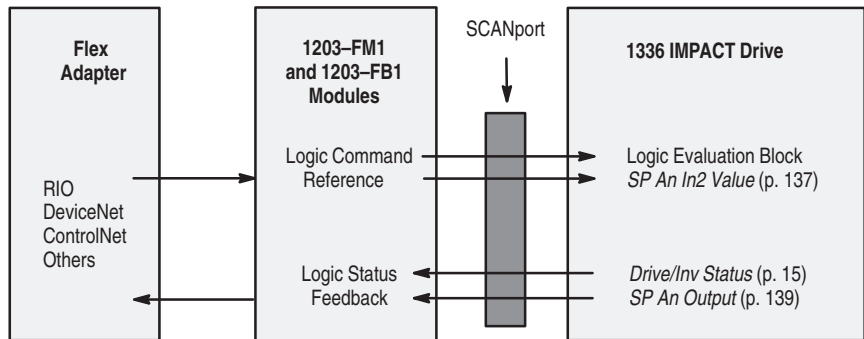
The following figure shows how the I/O image table for the programmable controller relates to the 1336 IMPACT drive when a Remote I/O Communications Module is used.



1 Optionally enabled using DIP switches on the module.

### Flex I/O Module

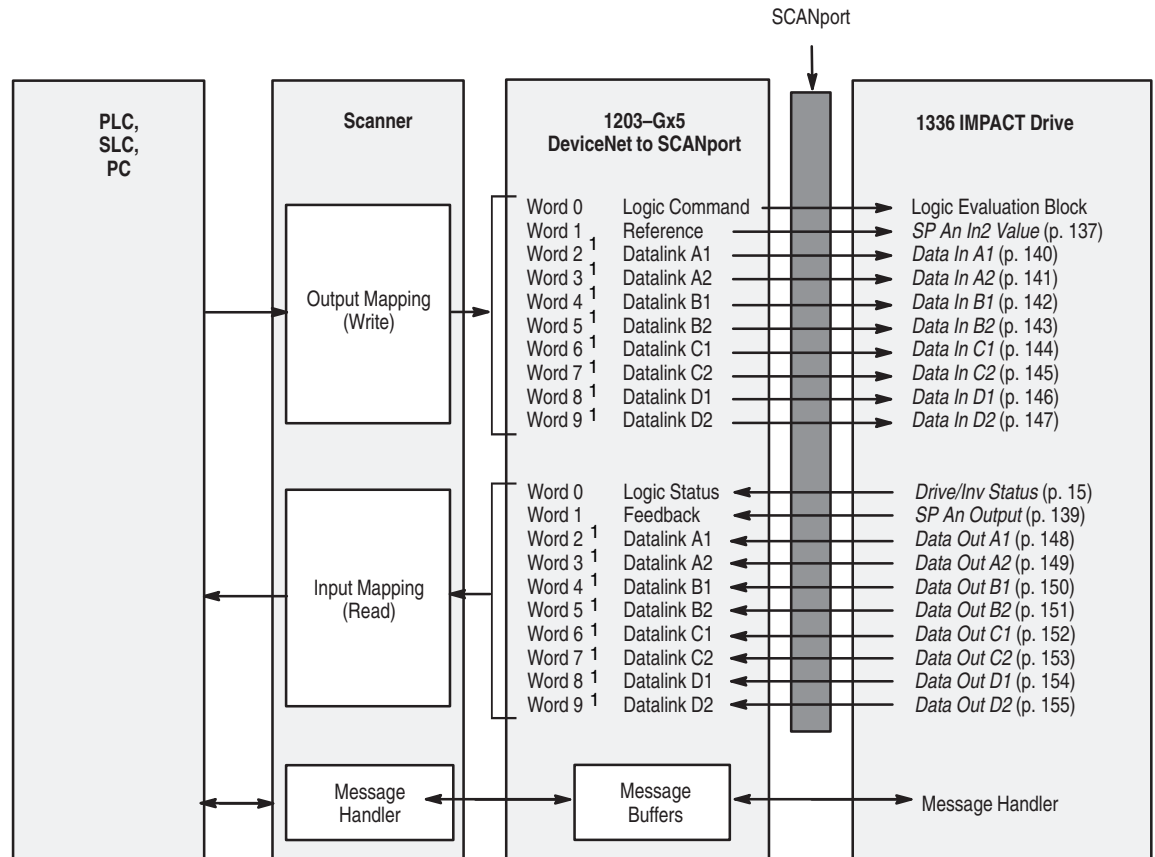
The following figure shows how the I/O image table for the programmable controller relates to the 1336 IMPACT drive when a Flex I/O Module is used.





## DeviceNet Communications Module

The following figure shows how the I/O image table for a DeviceNet scanner relates to the 1336 IMPACT drive when a DeviceNet Communications Module is used.



1 Optionally enabled using DIP switches on the module.

## Supported SCANport Messages

The 1336 IMPACT drive supports the following SCANport messages. The formats and methods to use these messages vary depending on the type of gateway used. Not all gateways support messaging or all message types. Consult your gateway manual(s) or application notes when determining the level of support for any gateway.



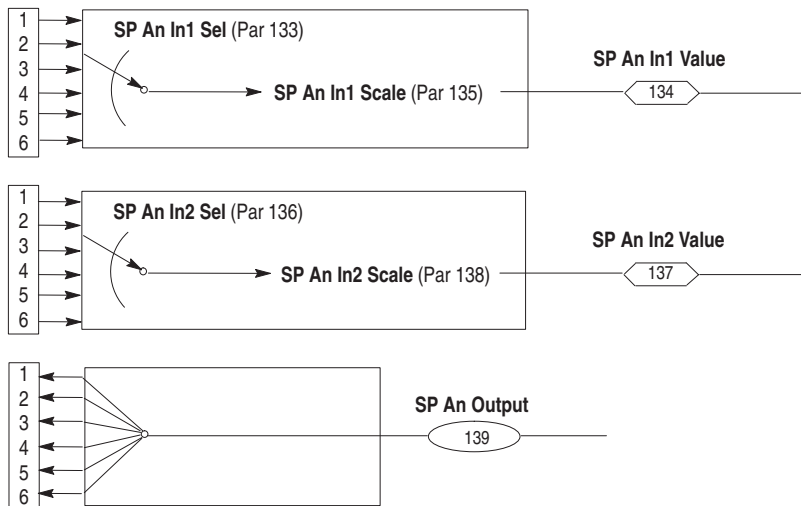
**ATTENTION:** Hazard of equipment damage exists. If messages (block transfer messages, explicit messages, unscheduled messages, etc.) are programmed to frequently write parameter data to a drive, the EEPROM (Non-Volatile Storage) will quickly exceed its life cycle and cause the drive to malfunction. Do not create a program that frequently writes messages to a drive. Datalinks do not write to the EEPROM and should be used for frequently changed parameters.

This message:	Lets you:
Continuous Parameter Value Read	Read a continuous list of parameters beginning with the starting parameter number.
Continuous Parameter Value Write	Write to a continuous list of parameters beginning with the starting parameter number.
Scattered Parameter Value Read	Read a scattered list of parameters.
Scattered Parameter Value Write	Write to a scattered list of parameters and return the status of each parameter.
Continuous Parameter Link Read	Read a continuous list of links beginning with the starting parameter number.
Continuous Parameter Link Write	Write a continuous list of links beginning with the starting parameter number.
Scattered Parameter Link Read	Read a scattered list of parameter links.
Scattered Parameter Link Write	Write a scattered list of parameter links.
Read Product Number	Request the product number from a device.
Product Text String Read	Request the product text from a device.
Last Parameter Number Read	Request the last parameter number.
EE Command Write	Activate the specified EE function.
Read Full Parameter	Request all known attributes for the requested parameters.
Parameter Value Read	Request the value for a specific parameter.
Parameter Value Write	Write a value to a specific parameter.
Fault Command Write	Clear faults, clear the fault queue, and reset.
Fault Queue Size	Read the number of fault entries allowed in the fault queue.
Trip Fault Read	Request which fault queue entry tripped the drive.
Fault Queue Entry Read Full	Read the contents of the specified fault queue entry.
Warning Command Write	Clear faults and clear the warning queue.
Warning Queue Size	Read the number of fault entries allowed in the warning queue.
Warning Queue Entry Read Full	Read the contents of the specified warning queue entry.
Link Command Write	Clear all links.
Read Parameter Link	Request the parameter link information for a specific parameter.
Write Parameter Link	Write the parameter link information for a specific parameter.
Product Diagnostic Value	Access a simple parameter link checksum.

### Setting Up the Analog I/O Parameters for SCANport

The following figure shows the six SCANports that are available for use with the SCANport analog I/O and the drive parameters that you can use to control this data.

*file:* Interface/Comm  
*group:* SCANport Analog



---

To receive analog input from a SCANport device, you need to:

1. Set *SP An In1 Sel* (parameter 133) to the SCANport device number.
2. Set the scale factor by using *SP An In1 Scale* (parameter 135).
3. Link a sink parameter to *SP An In1 Value* (parameter 134).

For example, if you plug a HIM into port 1 to control the external speed, you need to enter a value of 1 for *SP An In1 Sel* and link *Speed Ref 1* (parameter 29) to *SP An In1 Value*. You may scale the speed by using *SP An In1 Scale* or *Speed Scale 1* (parameter 30).

▶ *When setting the scale factor, keep in mind the internal scaling range of the SCANport device. For example, the HIM pot uses a range of 0 to 32767. Refer to the documentation for your SCANport device for information about the range of the SCANport device.*

The drive sends *SP An Output* (parameter 139) to all devices connected to SCANport. To send data out to the SCANport devices, link *SP An Output* to a source parameter. For example, if the HIM is to receive speed feedback, you would link *SP An Output to Motor Speed* (parameter 81).

**Notes:**

## Applications

Chapter 9 provides applications for using the 1336 IMPACT drive.

### Chapter Objectives

This Topic:	Starts On Page:
Choosing a motor feedback source	9-1
Choosing an optional braking/decelerating method	9-3
Using DC hold	9-6
Using up to 400% motor current	9-7
Understanding the scale and offset parameters for analog I/O	9-8
Using 4 – 20 mA inputs/outputs	9-11
Using a remote pot	9-12
Using MOP	9-14
Using Flying Start	9-14
Using Speed Profiling	9-16

### Choosing a Motor Feedback Source

The 1336 IMPACT drive has four sources for motor speed feedback:

- encoder feedback
- encoderless speed estimate
- encoderless speed estimate w/deadband
- motor simulation

To select either the encoder or the encoderless speed estimate, you need to make the selection in the Quick Start routine and run the autotune routines.

To choose the motor simulation mode, use *Fdbk Device Type* (parameter 64).

To use an encoder mode, you must have an L7E, L8E, or L9E L Option board. Refer to Chapter 5, *Using the L Option*, for information about the L Option board.

**Important:** If you are using your 1336 IMPACT drive for hoist-like applications, we strongly recommend that you use an encoder.

## How Do Encoderless and Encoder Feedback Modes Differ?

The following table compares the encoderless mode to the encoder feedback mode.

Category	Encoderless Mode	Encoder Feedback Mode
Speed regulation requirements	Applicable when requirements are larger than $\pm 0.5\%$ of base speed. May be applicable for requirements between $\pm 0.1\%$ and $\pm 0.5\%$ with manual adjustments.	Recommended for requirements smaller than $0.1\%$ of base speed.
Minimum speed <sup>1,2</sup>	Applicable when the minimum speed is greater than 1/60 of base speed (that is, 30 rpm on a 60 Hz, 4 pole motor). May be applicable down to speeds of 1/120 of base speed (15 rpm) if high bandwidth responses are not required.	Recommended for speeds less than 1/120 of base speed (15 rpm).
Maximum operating speed	Depends on the number of motor poles. A 4 pole motor has a maximum operating speed of 7200 rpm.	Depends on the number of motor poles. A 4 pole motor has a maximum operating speed of 7200 rpm.
Maximum speed bandwidths <sup>3</sup>	30 radians/second	100 radians/second
Starting torque <sup>4</sup>	150% of rated motor torque	150% of rated motor torque
Torque regulation	$\pm 5\%$	$\pm 2\%$
Start into spinning motor	Some cogging may occur	Smooth start
Speed range	120:1	1000:1
Output frequency range	0 – 250 Hz	0 – 250 Hz

1 Erratic operation, including cogging, may result at speeds less than 1/60 of base speed.

2 You can use *Min Speed Limit* (parameter 215) to adjust the minimum speed.

3 The maximum speed bandwidths are with no inertia connected to the motor. The maximum achievable bandwidths decrease with increasing connected inertia for both sensorless and encoder modes.

4 The available starting torque is at least 150% motor torque and could be as high as 300% if the inverter can supply the current. Refer to *Max Mtr Current* (parameter 195).

<p><i>file:</i> Motor/Inverter</p> <p><i>group:</i> Motor Constants</p>
---

### Improving Speed Regulation in Encoderless Mode

After completing the auto-tune tests, you can adjust *Slip Gain* (parameter 169) to improve the speed regulation (as a function of load) in encoderless mode. *Slip Gain* defaults to 100% and typically results in  $\pm 0.5\%$  speed regulation.

Ideally, you should adjust *Slip Gain* while the motor is fully loaded and at its normal operating temperature. Adjust *Slip Gain* until the actual speed, as measured by an independent source such as a hand tachometer, is equal to the desired speed. This should result in a minimum steady state speed deviation as load changes. The proper slip for good speed regulation also depends on the motor temperature; thus, if the motor operating temperature normally varies between cold and hot, select a compromise slip gain.

### Using the Motor Simulation Mode

You can use the motor simulation mode to simulate a system that does not have a motor present. This can be useful for testing purposes.

To select the motor simulation mode, enter a value of 3 in *Fdbk Device Type* (parameter 64). When you run simulation mode, the torque and flux current commands for the motor are set at near zero levels. Little, if any, torque is produced at the motor. A simulated motor speed is calculated based on the level of internal torque reference and total inertia. The speed regulator responds as if the motor were present and connected to the drive.

## Choosing an Optional Braking/Decelerating Method

*Bus/Brake Opts* (parameter 13) lets you choose a braking/ decelerating method. The following options are available:

This method:	Uses:	To select this method, you need to:
Dynamic braking	An external braking device. The full drive power is available for stopping. You must use this method if a linear and controlled speed deceleration is required. The other braking methods result in non-linear stop profiles.	Set bit 10, Brake/Regen, in <i>Bus/Brake Opts</i> .
Bus regulator	<i>Regen Power Lim</i> (parameter 76) to reduce the regenerative torque to limit the bus voltage in the device.	Clear bit 10, Brake/Regen, and bit 6, Flux Braking, in <i>Bus/Brake Opts</i> .
Flux braking	An increase in the motor flux to increase the motor losses.	Set bit 6, Flux Braking, and clear bit 10, Brake/Regen, in <i>Bus/Brake Opts</i> .
DC braking	DC current to increase the motor losses.	Set bit 9, DC Brake, and clear bit 10, Brake/Regen, in <i>Bus/Brake Opts</i> .

Choose the braking/decelerating method that works best for your motor and load.

You may also want to review the standard stop types that are available for the drive. These are covered in the Speed Reference Selection Overview section in Appendix B, *Control Block Diagrams*.

### Using Dynamic Braking/Brake Chopper

Dynamic braking uses an external braking device to dissipate the excess energy when the drive is decelerated. This setup disables the bus voltage regulator and relies on the dynamic brake to dissipate the excess regenerated energy.

**Important:** The dynamic brake must be connected to the capacitor side of the DC link choke (output side). If the brake is connected to the converter bridge of the DC link choke (input side), it will fail.

To use a dynamic brake:

1. Set bit 10, Brake/Regen, in *Bus/Brake Opts* (parameter 13).
2. Clear bit 5, Bus High Lim, in *Bus/Brake Opts* (parameter 13).
3. Refer to the manual that came with your brake for further information.
4. Set *Regen Power Lim* (parameter 76) according to the available braking power. If the brake is sized for maximum regenerative energy, then the *Regen Power Lim* (parameter 76) may be set to its highest value.
5. If overvoltage occurs, see below.

If bus overvoltages occur, then the brake is not large enough to dissipate the excess energy. Either increase the brake size or limit regenerative energy until the overvoltages no longer occur.

The regenerative energy may be limited either automatically by letting the bus regulator work along with the dynamic brake or manually by reducing the regenerative energy. Normally, automatic limiting by the bus voltage regulator is preferred because manual limiting may have to be repeated if the regenerative energy changes due to load, speed, or system losses.

To stop overvoltages automatically, you must enable the bus voltage regulator with the dynamic brake. Follow these directions:

1. Set bit 5, Bus High Lim, in *Bus/Brake Opts* (parameter 13).
2. Set bit 10, Brake/Regn, in *Bus/Brake Opts* (parameter 13). This sets the bus voltage regulator operation to a higher voltage.
3. If overvoltages still occur, then manually reduce the *Regen Power Lim* (parameter 76). See below.

To stop overvoltages manually, you must limit the regenerated energy by either extending the deceleration time or reducing the regenerated power limit.

- To extend the deceleration time, set *Decel Time 1* (parameter 44) and *Decel Time 2* (parameter 45) to the desired values.
- To reduce the regenerated power limit, set *Regen Power Lim* (parameter 76) to the desired value.

### Using the Bus Regulator for Braking

If you are not using a dynamic brake, the bus regulator is the default braking method as selected during the Quick Start routine.

To enable bus regulator braking:

1. Clear bit 10, Brake/Regen, in *Bus/Brake Opts* (parameter 13).
2. Clear bit 6, Flux Braking, in *Bus/Brake Opts*.
3. Clear bit 5, Bus High Lim, in *Bus/Brake Opts*.

As the motor is decelerated or as regeneration occurs (for example, an overhauling load), energy is transferred from the motor to the drive. This causes an increase in the bus voltage. When the bus voltage becomes high enough, the bus voltage regulator becomes active and reduces the regeneration power limit to control the bus voltage. The maximum regeneration power limit is controlled in *Regen Power Lim* (parameter 76), and the bus voltage regulator automatically further reduces this level as needed to limit the bus voltage. The regeneration power limit implements a torque limit as a function of motor speed times torque. Then, the system power losses determine the motor deceleration.

The default bus regulator braking set up uses a -25% regenerative power limit, *Regen Power Lim*. If the losses in the system are large enough, you may use a larger value.

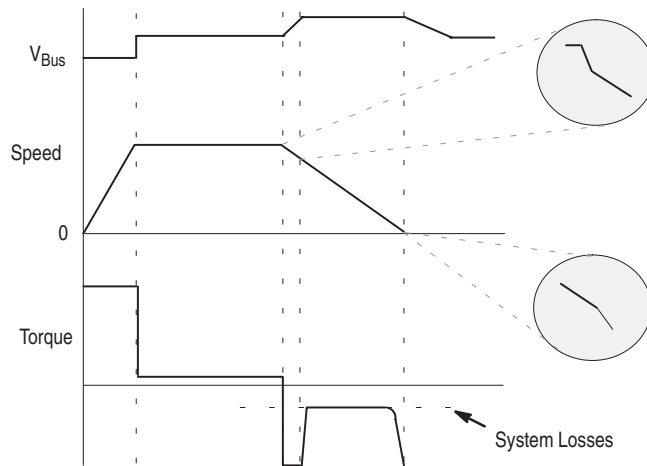
<p><i>file:</i> Application</p> <p><i>group:</i> Bus Control</p>
--

<p><i>file:</i> Control</p> <p><i>group:</i> Control Limits</p>
---



Figure 9.1 shows how the bus regulator relates to both speed and torque.

**Figure 9.1**  
**Bus Regulator in Relation to Speed and Torque**



### Using Flux Braking

You can use flux braking to stop the drive or to shorten the deceleration time to a lower speed. The higher losses result in a shorter motor deceleration time. Other methods of deceleration or stopping may perform better depending on the motor and the load.

To enable flux braking:

1. Set bit 6, Flux Braking, in *Bus/Brake Opts* (parameter 13).
1. Clear bit 10, Brake/Regen, in *Bus/Brake Opts*.
1. Clear bit 5, Bus High Lim, in *Bus/Brake Opts*.

As the motor is decelerated or as regeneration occurs, energy is transferred from the motor to the drive. This increases the bus voltage. When the bus voltage becomes high enough, the bus voltage regulator becomes active and reduces the regeneration power limit to control the bus voltage. The maximum regeneration power limit is controlled in *Regen Power Lim* (parameter 76), and the bus voltage regulator automatically further reduces this level as needed to limit the bus voltage.

When enabled, flux braking automatically increases the motor flux resulting in an increase of motor losses. The flux current is only increased when the bus voltage regulator is active. When the bus voltage regulator is not active, the flux current is returned to normal. The maximum flux current is equal to rated motor current but may be further reduced depending on the load level, IT protection, or current limits. In general, the flux current is not increased when the motor is at or above rated speed. At higher speeds, field weakening is active and the motor flux current cannot be increased. As the speed decreases below base speed, the flux current increases until there is enough voltage margin to run rated motor current.

*file:* Application  
*group:* Flux Braking

*file:* Control  
*group:* Control Limits

In a few applications (typically greater than 200HP), the flux braking may interact with the field weakening control. This may result in a bus overvoltage fault. If this occurs, increase *Decel Time 1* (parameter 44) and/or *Decel Time 2* (parameter 45) as needed.

Because flux braking increases motor losses, the duty cycle used with this method must be limited. Check with the motor vendor for flux braking or DC braking application guidelines. You may also want to consider using external motor thermal protection.

### Using DC Braking

DC braking only becomes active during a stop (not including coast stop) and is not active during normal decelerations. Other stopping methods may perform better depending on the motor and the load being stopped.

*file:* Application  
*group:* DC Braking/Hold

To enable DC braking:

1. Set bit 9, DC Brake, in *Bus/Brake Opts* (parameter 13).
2. Clear bit 10, Brake/Regen, in *Bus/Brake Opts*.
3. Clear bit 5, Bus High Lim, in *Bus/Brake Opts*.

When DC braking is enabled and you command a stop, DC current is applied to the motor. This increases motor losses and may result in a shorter motor deceleration time. *DC Brake Current* (parameter 79) controls the magnitude of DC current applied. The magnitude has a maximum range of 70% of the drive rated current. Current limit and IT protection (for times greater than 60 seconds) can further reduce the applied *DC Brake Time* (parameter 80). Typically, you will measure the stopping time that you should enter in *DC Brake Time*.

Because DC braking increases motor losses, the duty cycle of stopping with this method must be limited. Check with the motor vendor for DC braking application guidelines. You may also want to consider using external motor thermal protection.

You can use DC hold when the 1336 IMPACT drive is set up for encoderless operation and some level of resisting torque is desired at near zero speed.

### Using DC Hold

After the motor is stopped, DC current is applied to the motor. Although speed and torque are not controlled, the DC current results in resisting torque when the motor shaft is rotated. As the motor speed increases towards the rated slip for the motor, a very high resisting torque can be produced.

Only use DC hold for encoderless operation where torque control at zero speed cannot be guaranteed. For encoder operation, full torque and speed control is provided at zero speed and you should use the normal torque or speed controls.



**ATTENTION:** A hazard of electric shock or motor movement does exist. When you stop the drive using DC hold, power is not removed from the motor. You may want to provide an alternate way to disconnect power completely from the motor.

---



**ATTENTION:** DC hold runs for an indefinite period of time. DC hold becomes active only after you have commanded a stop. When the stop function completes, the DC hold function starts. The DC hold continues until you command a start, disable the drive (enable removed), or command a coast stop. To issue a coast stop, set bit 8 in *Logic Input* (parameter 14) or set any type of stop after configuring the coast stop select in *Logic Options* (parameter 17) — coast stop option 1 or 12 per drive set up.

---

When the motor is stopped, the hold function provides an indefinite duration of DC current. The level of DC current is set by the *DC Brake Current* (parameter 79) level but is limited by 70% of drive rated current, IT protection, or current limit, whichever is less. This function is not available when you enable a coast to stop.

To enable DC hold, set bit 7 in *Bus/Brake Opts* (parameter 13).

---



**ATTENTION:** A hazard of electric shock does exist. You can only change *Bus/Brake Opts* when the drive is disabled. If the drive is enabled, you cannot turn off the DC hold function by clearing bit 7.

---

Because the actual motor losses are not known when DC hold is active, you must determine thermally safe operating times and levels. Check with the motor vendor for DC braking or DC hold application guidelines. You may also want to consider using external motor thermal protection.

A limited hold time can be provided by using the DC braking function with an extended DC brake time.

## Using Up to 400% Motor Current

<p><i>file:</i> Control <i>group:</i> Control Limits</p>
--

By default, the 1336 IMPACT drive uses a maximum of 200% motor current. However, for some applications that use a drive that is significantly larger than the motor, you may use a maximum of 400% motor current.

In all cases where the drive current limit (typically 150% of drive rated current for 1 minute) is less than 400% motor current, the drive current limit is used to determine the maximum available motor current. The available current range is shown as the maximum current limit value in *Pos Mtr Cur Lim* (parameter 72) and *Neg Mtr Cur Lim* (parameter 73).

*file:* Application  
*group:* 400% Mtr Current

When:	The maximum current is:
<i>Max Mtr Current</i> (parameter 195) is 1	400% motor current.
<i>Max Mtr Current</i> is 0	200% motor current.
The drive current limit is less than the motor current limit	Determined by the drive current limit.

To enable the 400% motor current function, set *Max Mtr Current* (parameter 195) to a value of 1.

**Important:** When you enable the 400% motor current function, you should be aware that torque regulation specifications only apply to the 0 – 100% torque range.

When the drive is configured for 400% motor current, the current loops are rescaled to allow a larger range of motor current at the expense of decreased current resolution. Only use the increased current range for large drive to motor ratios. In cases where there is not a large difference between the drive rated current and the motor rated current, little added benefit is provided for most applications. The increased current range results in decreased current resolution and therefore a decreased signal to noise ratio for the current feedback. All other drive operations remain the same.

The duty cycle for operation above 100% load (for example, 400% motor current) must be limited to thermally protect the motor. Check with the motor vendor for duty cycle guidelines. You may want to consider using external motor thermal protection.

**Important:** The maximum current limits that you specify in *Pos Mtr Cur Lim* and *Neg Mtr Cur Lim* set the maximum/ minimum values for *Pos Torque Lim* (parameter 74) and *Neg Torque Lim* (parameter 75). If you lower the values of *Pos Mtr Cur Lim* and *Neg Mtr Cur Lim*, you will clamp the values of *Pos Torque Lim* and *Neg Torque Lim*. If you later raise the value of *Pos Mtr Cur Lim* and *Neg Mtr Cur Lim*, the values of *Pos Torque Lim* and *Neg Torque Lim* remain at the lower value.

## Understanding the Scale and Offset Parameters for Analog I/O

*file:* Interface/Comm  
*group:* Analog Inputs

The following section provides information to help you understand and use the scale and offset parameters for analog I/O. This is an alternate method for determining values for your scale and offset parameters.

### Understanding the Scale and Offset Parameters for Input

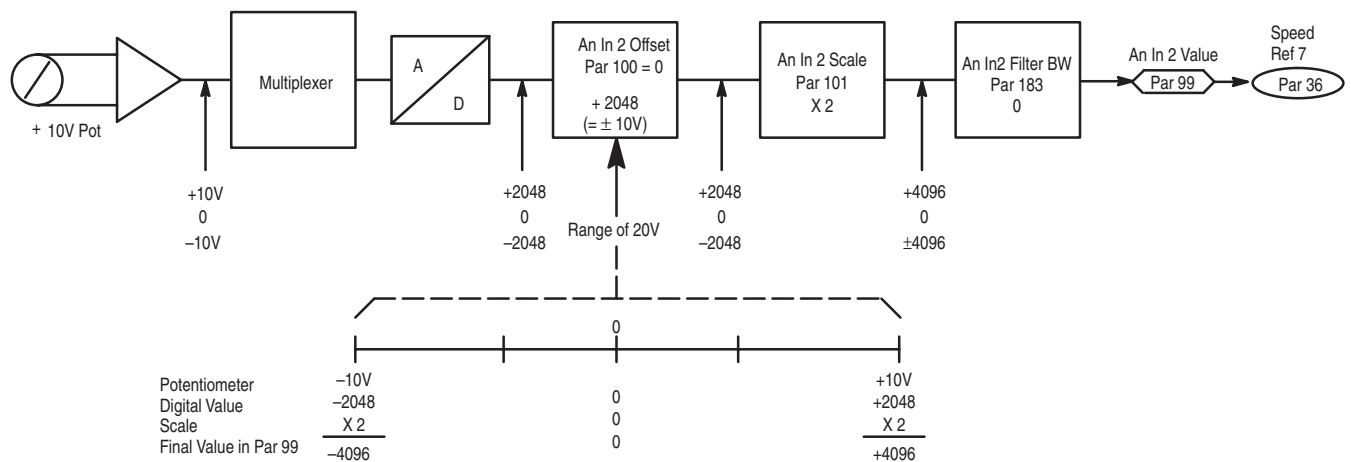
In example 1, a potentiometer with a range of  $\pm 10$ V DC has been connected at analog input 2. *An In 2 Value* (parameter 99) has been linked to *Speed Ref 7* (parameter 36) in the drive, which gives the potentiometer control of speed reference 7.

To calibrate the pot to control 100% base speed in both directions, you need to adjust the scale parameter. The default value of the scale parameter allows a total range of 4096, -2048 to +2048. This allows only 50% base speed in each direction. By setting a scale factor of 2 in *An In 2 Scale* (parameter 101), the digital input is multiplied by 2. This provides a range of  $\pm 4096$ , or 100% base speed in both directions.

If you want a range of  $\pm 2$  times base speed, the scale factor would be 4 (base speed is 4096, 2 times base speed is 8192, 2048 times 4 is 8192). *An In 2 Offset* (parameter 100) remains at the default value of zero, allowing the input range to be  $\pm 10V$ . The range of the offset parameter is  $\pm 20V$  DC as shown in Figure 9.2.

In this example, the filter parameter, *An In2 Filter BW* (parameter 183), is not used. The filter parameter is a low pass filter that helps to reduce the affects of noise on the system.

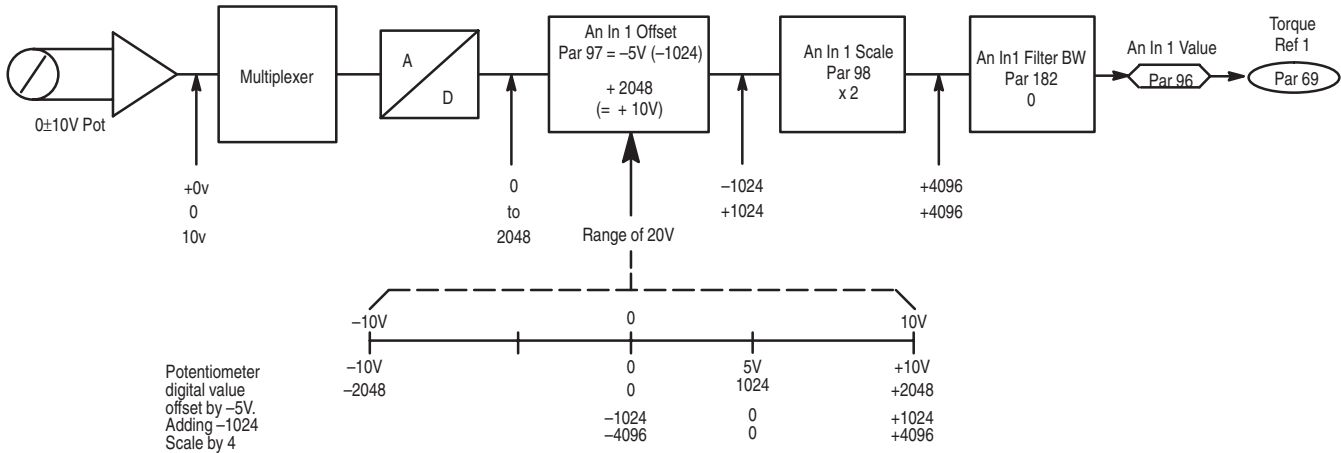
**Figure 9.2**  
**Potentiometer with +10V Range to Control 0 to +100% Base Speed**



For a second example, a 0 to 10 volt potentiometer adjusts the torque reference from -100% to +100%. To do this, you need to adjust both the scale and offset parameters. By linking *An In 1 Value* (parameter 96) to *Torque Ref 1* (parameter 69), the potentiometer connected to analog input 1 becomes the torque reference signal. This signal must be scaled and offset to get the entire  $\pm 100\%$  in the 0 to 10 volt range. A digital range of 8192 ( $\pm 4096$ ) must now be scaled for an analog range of 10 volts, and must be offset so 5 volts on the potentiometer indicates 0% torque.

As shown in Figure 9.3 the offset voltage adds the corresponding digital value to the range. In this case, an offset of -5 volts adds a digital value of -1024 to the range. This causes 0 volts on the potentiometer to register as -1024 digital internal to the drive and 10 volts on the potentiometer is +1024 to the drive. This can then be scaled by a factor of 4 (8192 drive units) so that 0 volts sends a digital value of -4096 for -100% torque, and 10 volts sends a digital value of +4096 for +100% torque.

**Figure 9.3**  
**Potentiometer 0 – 10V Range to Control 100% Torque Reference**



**Understanding the Scale and Offset Parameters for Output**

Analog outputs are similar to analog inputs. Each output has a scale and offset parameter, along with a specific variable parameter used for linking. Differences occur because of the direction of information flow. The drive sends a digital value in drive units, which must be matched to the voltage of the monitoring device. Similar to analog inputs, the analog output converts a  $\pm 2048$  value to  $\pm 10V$  DC. Thus, when the drive sends  $\pm 100\%$  base speed (equal to  $\pm 4096$ ), it must be scaled by 0.5 to be in the proper range ( $\pm 4096 \cdot 0.5 = \pm 2048$ ). The offset can be  $\pm 20V$  DC, even though the physical limit is  $\pm 10V$  DC. This lets you offset the signal anywhere within the entire range.

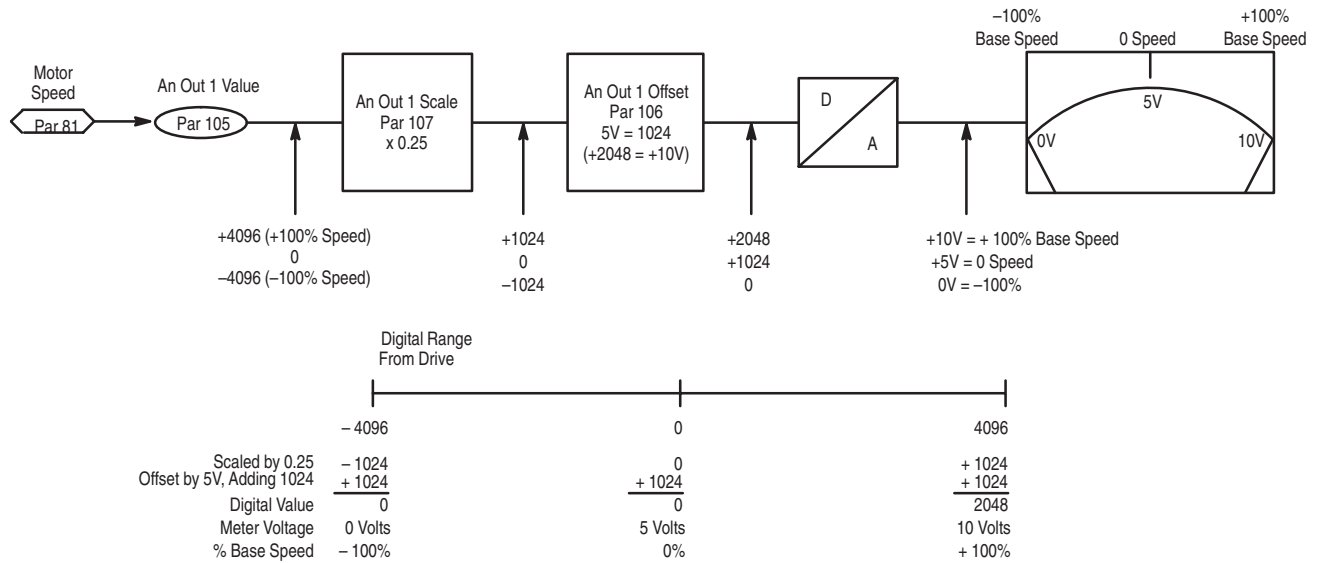
file: Interface/Comm  
group: Analog Outputs

In Figure 9.4, *An Out 1 Value* (parameter 105) is used as an example to show the scale and offset parameters. At *An Out 1 Value*, a meter with a range of 0 to 10V DC has been connected. *An Out 1 Value* has been linked to *Motor Speed* (parameter 81).

For the meter to indicate speed in both directions, adjust the scale and offset parameters as shown in Figure 9.4. Working in the opposite direction as the analog inputs, apply the scale factor first. The drive sends a  $\pm 4096$  digital value to indicate  $\pm 100\%$  speed feedback for a total digital range of 8192. The meter, having an analog range of 0 to 10V DC, requires a digital range of 2048. To do this, apply a scale factor of 0.25 ( $8192 \cdot 0.25 = 2048$ ).

To have the 0 to 10V DC meter indicate  $\pm 100\%$  feedback, you need to apply an offset. Offset parameters for analog outputs again adds the corresponding digital value to the range. In this case, an offset of 5 volts adds a digital value of 1024 to the range. This allows full range deflection on the 0 to 10 volt meter, with 5 volts indicating zero speed.

**Figure 9.4**  
**Analog Output 1 +100% Speed Indication**



**Using 4 – 20 mA Inputs/Outputs**

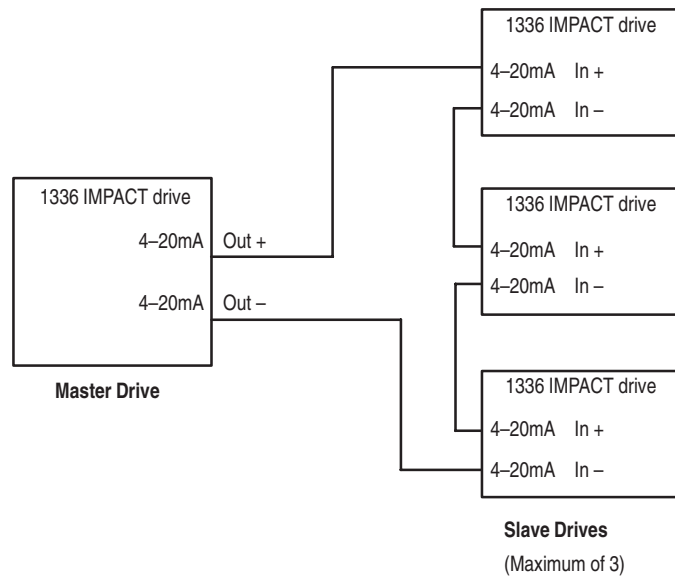
The 1336 IMPACT drive provides a 4 – 20 mA input and a 4 – 20 mA output. You can use the parameters that are available for the 4 – 20 mA input and output in the same way that you would use the analog input and output parameters. For example, you can use a scale, offset, and/or filter parameter to adjust the input value and a scale and/or offset parameter to adjust the output value.

Two advantages for using the 4 – 20 mA are:

- The current supply is regulated to adjust the voltage as needed to keep a constant current moving through the system.
- Noise in the system does not affect current as much as it does voltage.

Figure 9.5 shows an example of a 1336 IMPACT drive that is used as a master drive to control three other 1336 IMPACT drives. Notice that you can have a maximum of three slave drives.

**Figure 9.5**  
**An Example of a 4 – 20 mA Application**



## Using a Remote Pot

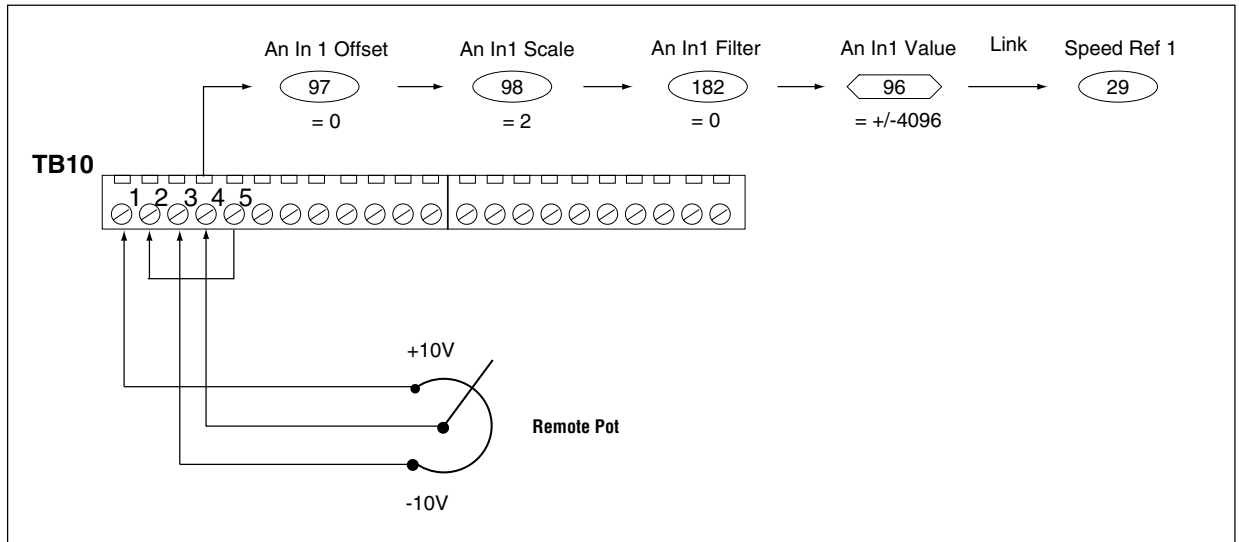
For some applications, you may want to wire a remote pot to your 1336 IMPACT drive. This section provides two examples of how you might wire a remote pot to your drive and configure the appropriate parameters. These are only examples.

For more specific information about:	Refer to:
Wiring the analog inputs	Chapter 2
Setting up your analog parameters	Chapter 7
Specifying direction	Appendix B

The first example is shown in Figure 9.6. In this example, a  $\pm 10V$  pot is wired to a D frame drive to provide speed control. This example could apply to any B – H frame drive. However, if you are using an A1 – A4 frame drive, you would use terminal block TB7 shown in Figure 3.3.



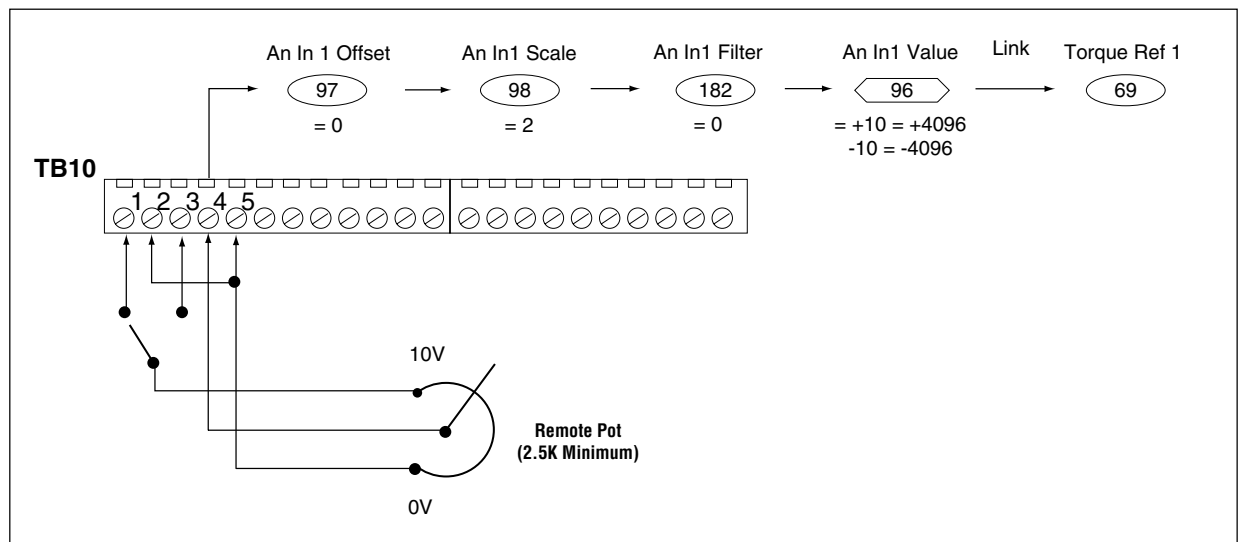
**Figure 9.6**  
**An Example of a Remote 10V Pot Wired to a D Frame Drive**



In this example, *An In 1 Offset* (parameter 97) is set to 0, and *An In 1 Scale* (parameter 98) is set to 2. This lets the drive use the full  $\pm 4096$  internal drive units. A link was also made so that *Speed Ref 1* (parameter 28) would receive the value of *An In 1 Value* (parameter 96) as its speed reference.

The second example is shown in Figure 9.7. In this example, a 0 – 10V pot is wired to a D frame drive to provide speed control. This example could also apply to any B – H frame drive.

**Figure 9.7**  
**An Example of a Remote 0 – 10V Pot Wired to a D Frame Drive**



In this example, the remote pot is set to use the 10V input. You could also set it up to use the -10V input. *An In 1 Offset* (parameter 97) is set to 0, and *An In 1 Scale* (parameter 98) is set to 2 to provide the full -4096 to 0 or 0 to +4096 internal drive units based on the switch position. A link was also made so that *Torque Ref 1* (parameter 69) would receive the value of *An In 1 Value* (parameter 96) as its torque reference.

## Using MOP

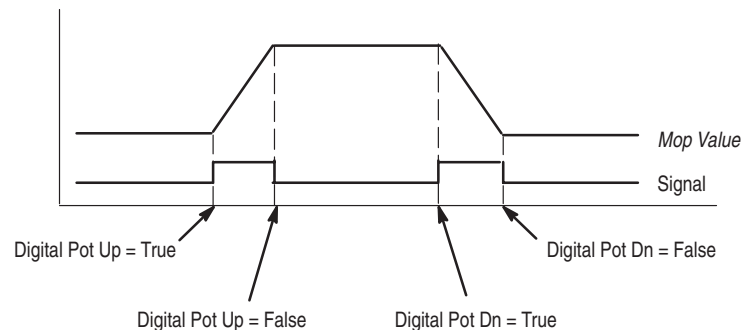
The MOP, or Manually Operated Potentiometer, feature lets you use inputs to the L Option board to control the speed or torque of the drive. You must have an L Option board to access the MOP feature.

To use the MOP feature, you need to:

1. Set *L Option Mode* (parameter 116) to a value of 5, 9, 10, or 15. You must use one of these modes because these are the only modes that provide access to Digital Pot Up/Dn.
2. Set *Mop Increment* (parameter 118) to a value in rpms/second. This value sets the rate of increase or decrease to the MOP.
3. Link *Mop Value* (parameter 119) to either a speed or a torque reference. For example, you could link *Mop Value* to *Speed Ref 1* (parameter 29) if you want the drive to follow the MOP command for speed.

When the Digital Pot Up is true, the value of *Mop Increment* is added to *Mop Value*, and when the Digital Pot Dn is true, the value of *Mop Increment* is subtracted from *Mop Value*. This lets you control the speed through the MOP as shown in Figure 9.8.

**Figure 9.8**  
Example of the MOP Feature

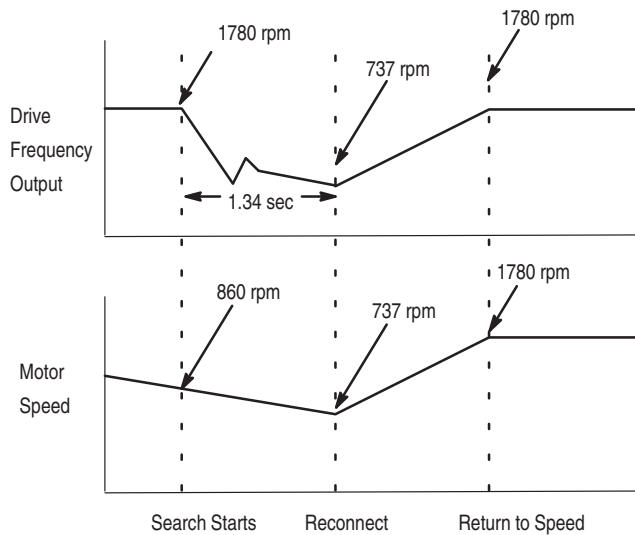


## Using Flying Start

The flying start feature lets you start a drive when the connected motor is rotating. When you activate the flying start feature, the drive starts at either the last known speed or a speed that you enter.

As an example, you want to reconnect to a motor that is rotating at 860 rpm. You set *Fstart Select* to 2 and set *Fstart Speed* to +1780 rpm. The drive searches for 1.34 seconds and then reconnects to the motor at +737 rpm. Figure 9.9 illustrates this example.

**Figure 9.9**  
**Example of a Flying Start**



Once enabled, the flying start feature remains on until you set *Fstart Select* to 0. If flying start is on when you perform a start from zero, it adds time to the start.

**NOTE:** The Flying Start Feature is only necessary for a drive in the sensorless mode. If an encoder is present, Flying Start is inherent.

### Flying Start from Last Known Speed

**Important:** It is not recommended that you start the flying start search from the last known speed if your drive is operating in torque mode.

To start the flying start from the last known speed, you need to:

1. Set *Fstart Select* (parameter 216) to 1.
2. Start the drive.

**Important:** The following conditions reset the last known speed to zero: cycling drive power, resetting the drive, clearing a hardware fault (IOC, BOV, DESAT, or Ground fault).

### Flying Start from Selected Speed

To start the flying start from a speed that you set, you need to:

1. Set *Fstart Select* (parameter 216) to 2.
2. Set *Fstart Speed* (parameter 217) to the speed at which you want to begin the search.
3. Start the drive.

**Important:** To maximize performance, set *Fstart Speed* slightly greater than the speed at which you expect to reconnect to the motor.

**NOTE:** The Forward and Reverse Speed Limit **MUST** be set to the same magnitude to prevent Absolute Overspeed Fault.

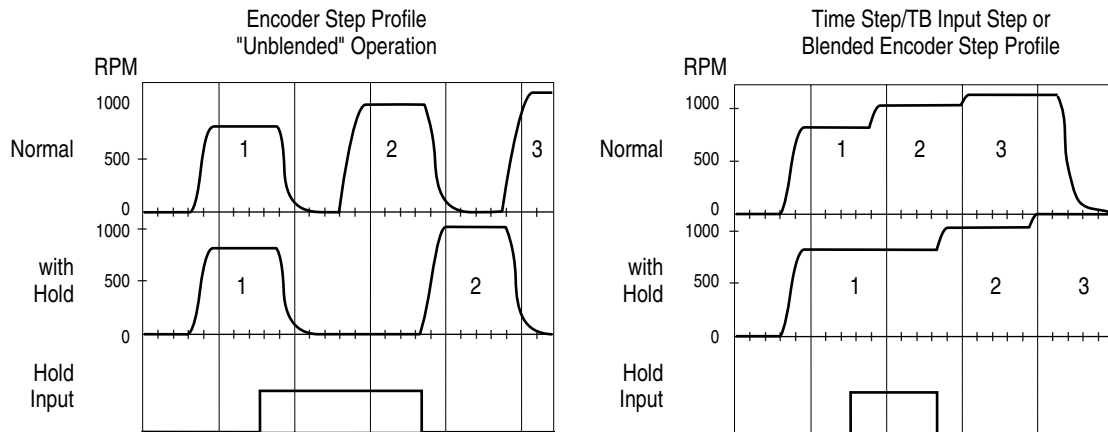
## Speed Profiling Introduction

This feature provides a series of 16 programmable steps that allow you to program a sequence of speed command transitions. Each step can be activated based on time, digital inputs, or encoder counts. The profile can be used as a single sequence with a return to a “home”, or as a continuous loop, returning to an initial step value each time. This feature can be used for simple positioning requirements on applications such as turntables, hemmers, gantries, run-out tables, transfer shuttles and station gates.

**NOTE:** The Speed Profile feature is not intended to be used in conjunction with certain other features in the drive. These include Function Blocks, Process Trim or Bus Regulation. Using these features in combination with Speed Profiling may result in inconsistent operation that cannot be guaranteed.

The Speed Profile is configured using a command word, and end action parameters. Each available step is configured with three parameters, which define the speed (in RPM) to operate during the step and when to end the step. The amount of travel for each step is controlled by the type of trigger which ends or terminates the step and is based on time, encoder count, or digital input. In addition, parameters for monitoring and status information are available.

The Profile Enable Parameter (P235) enables the profile, defines the “home” position, begins the actual sequence, and allows for a profile “Hold” (Refer to page 9-21). In addition, it defines how to transition between each profile step. An enable bit sets the “Home” position, and must be set to 1 for the profile feature to operate. “Home” position is redefined any time this bit is toggled to a 1. A run Sequence bit, is used to actually begin the sequence operation, once a start command has been given to the drive. An Encoder Velocity Blend bit defines if the drive will come to zero speed between each step, or “blend” the step value, and make a smooth transition from one step speed to another. An example of this is shown below.



## Speed Profiling Operation

Each step is defined by three configuration parameters-

**A** - The **Speed** in rpm during the step [*Step Speed* ]

**B** - The **Step Value** [*Step Value* ]

**C** - The **Type** of Step to perform (time based, digital input activated, or encoder count based) [*Step Type*]

Parameter No.	
#249	SPEED
#250	VALUE
#251	TYPE

The Profile control will output the selected **Step Speed** until the conditions of the **Step Type** and **Value** are met.

Each step transition can be turned off or be one of three active **types**.

If a **STEP TYPE** parameter:

- = 0, the step is turned **Off**
- = 1, the step is **time** based
- = 2, **Tb3 input** based
- = 3, **Encoder Count** based

The Step Type is determined by the third parameter in each parameter group. The value of the **Step Type** parameter will change the meaning of the **Step Value** parameter (P#250).

In our first example, we will make the first step time based by entering a value of 1 in the **Step Type** parameter. Changing the value of the **Step Type** parameter #251 from a 0 to a 1, turns the step on, and tells the control to interpret the step value in units of seconds.

Enter 400 rpm in the **Step 1 Speed** parameter #249.

Enter 10 seconds in the **Step Value** parameter #250.

### EXAMPLE 1 (First Step)

P249 [Step 1 Speed ] = +400 rpm

P250 [Step 1 Value] = 10 seconds

P251 [Step 1 Type] = 1 Time Step

To program a second step, we would setup the parameters #252 through #254.

Enter 1700 in **Step Speed** parameter #252. Turn the step on by entering a value of 1 in the **Step Type** parameter #254. Enter 10 seconds in the **Step Value** parameter #253.

### EXAMPLE 1 (Second Step)

P252 [Step 2 Speed ] = +1700 rpm

P253 [Step 2 Value] = 10 seconds

P254 [Step 2 Type] = 1 Time Step

**Description of Operation (Second Step)** - In example #1, the Speed profile would command 400 rpm for 10 seconds based on the information in Step 1. The Speed Profile would then proceed to Step #2 and command 1700 rpm for another 10 seconds. The control will then proceed to the next step. Since Step #3 is not configured, the profile will end and command zero speed.

**End Actions** - When the profile control is at the end of a sequence a variety of actions can be taken. These are called **End Actions**. The end actions are selected by parameter #238 [End Action Select] and are configured via the **End Action (EA)** parameters #239 through #243.

The kinds of **End Actions** available are:

If Parameter 238 (End Action Select)

- = 0, Command zero speed.
- = 1, **Goto EA** - Goto step indicated by parameter #240.
- = 2, **Input EA** - End action speed (P #239) until TB3 input transitions and then commands zero speed.
- = 3, **Compare EA** - Command EA speed (P#239) until compare parameter (P#242) equals compare value (P#243).
- = 4, **Home EA** - Command EA speed (P#239) until motor returns to home position.

To cause the first profile to continually loop from step #2 back to step #1, you would use the **Goto end** action.

Enter a value of 1 in the End Action (EA) select parameter. Then select the target step by entering a value of 1 in the **EA Goto** parameter #240.

When enabled, the profile will continually sequence between the Step 1 speed of 400 rpm, and the Step 2 speed of 1700 rpm in 10 second intervals. This will continue until the profile is turned off via the Profile Enable Parameter #235 (clearing bit 0).

The other End Action options (TB3 input, Compare and Home End), will be discussed in more detail in a later section.

## Speed Profile Start Up Configuration

There are a variety of functions that must be configured before a Speed Profile can be used with a drive. For this reason, additional functionality was added to the **Start Up** procedure to simplify this configuration.

If you have not entered the motor parameters or tuned the motor yet, please use the **Quick Tune** procedure of the **Start Up** sequence at this time.

*If you are not familiar with the Start Up and Quick Motor Tune features of the IMPACT, please review section 6-8 through 6-11 in this manual.*

When the motor tune is complete, **bypass** the **Digital** section and the **Analog Reference** section of start up to reach **Speed Profile Configuration**.

## Speed Profile Configuration

1. Enter a **YES** to the “Configure Speed Prof?” question.
2. Say **YES** to the Encoder operation for the drive question.
3. Set **counts per unit** (Parameter 245) for the encoder 4 x PPR (P8). For a 1024 encoder enter 4096.
4. Set **Value Tolerance** parameter #244. For now it can be left at its default value of 20 counts.
5. Select a **Stop End Action** (Parameter 238 [End Action Sel]). Five possible end actions are available as detailed in P 238.
6. We have already activated 2 steps in the Speed Profile Introduction, so you can enter a **NO** to activating further steps. However, if you want to add more steps to your profile, reply **YES** and follow the steps in A thru C.
  - A. Set required *Step Speed* parameters (Param 255, 258 etc. etc.) An RPM value will be entered in these parameters.
  - B. Set the *Step Type* parameters (Param 257, 260 etc. etc.)
    1. Entering a value of 1 in a *Step Type* Parameter selects a **Time Step** (value outputted in seconds).
    2. Entering a value of 2 selects a **TB3 Input Step**. (This option can only be used with an L Option Card). The speed will be outputted until the selected TB3 terminal transitions from low to high input.
    3. Entering a value of 3 selects an **Encoder Step** (Value outputted in units).
    4. Entering a value of 0 selects Not Used, which forces an End Action.
  - C. Set required Step Value parameters (Param 256, 259 etc. etc). This value will be in seconds, encoder counts or TB3 inputs depending on the selection made in the corresponding *Step Type* parameter.  
For Example: Entering a value of 1 in Parameter 257 will require a time in seconds entry in Parameter 256.

## Initial Setup Requirements

As mentioned previously, a number of parameters were adjusted to configure Speed Profiling. These modifications were performed automatically when the Speed Profile Configuration option was selected from the Startup menu.

In the following section we will identify all the automatic changes that were made. An explanation of operation is provided to allow you to make a decision on whether each step should be manually modified to meet your desired setup.

### Accel/Decel Rates

**Parameter #42** [Accel Rate 1] and **Parameter #44** [Decel Rate 1] were both be set to .8 seconds.

The acceleration and deceleration control is part of the speed PI regulator. It is important that the rate limits set in the PI regulator do not interfere with the speed profile regulator.

For Example: If the deceleration rate in the speed PI regulator is set too long, the control of the speed profile loop will not be followed. The result will be an overshoot of the programmed travel distance. If the decel rate is lowered, then the overall cycle of the speed profile is increased.

### Profile Speed Command

Profile Speed Command outputs were linked into Speed Ref 1. The 32 bit command is used for fine positioning in encoder mode.

- A. Parameter #247 (*Profile CMD Frac*) linked to Parameter #28 (*Speed Ref 1 Frac*).
- B. Parameter #248 (*Profile CMD*) linked to Parameter #29 (*Speed Ref 1*).

### Bipolar Signal Reference

**Parameter 17** {Logic Options} **bit 11** “Bipolar Sref” must be set to 1 to enable bipolar reference for speed and direction control.

If this is not set for bipolar operation, a reverse speed command (which is a negative value) cannot occur. As a result, the profile will “lock-up” when the first negative speed step is encountered.

### Bus Regulation Turned Off

Bus Regulation is turned OFF when parameter 13 bit 10 is cleared (bit 10 set to “0”). This is so the speed profile control will NOT be overridden by the bus regulator when bit 10 is set to zero.

*NOTE: Using bus voltage regulation with the speed profile feature is Not Recommended.*

If bus regulation is enabled, the motor may not reach commanded speed and could cause an over-travel condition on the speed profile steps.

### Relay Output Configuration

When Speed Profiling is enabled, parameter 191[Relay 4 Config] is set to 39 “@ Profile Pos”.

This relay will energize when each “encoder step” reaches the step position within the set tolerance (p 244).

### Motor Current Limits

Parameter #73 Negative Motor Current is set to -200%.

If the drive runs into a current or torque limit during a **timed step**, the programmed travel time will be increased. For **TB3 input** and **encoder steps**, the time to travel a given distance will be increased if this situation occurs.

### Torque Mode

Set **Parameter #68** [Torque Mode] to a value of 1.

### TB Input Mode

**Parameter # 116** should be set to a value of 31.

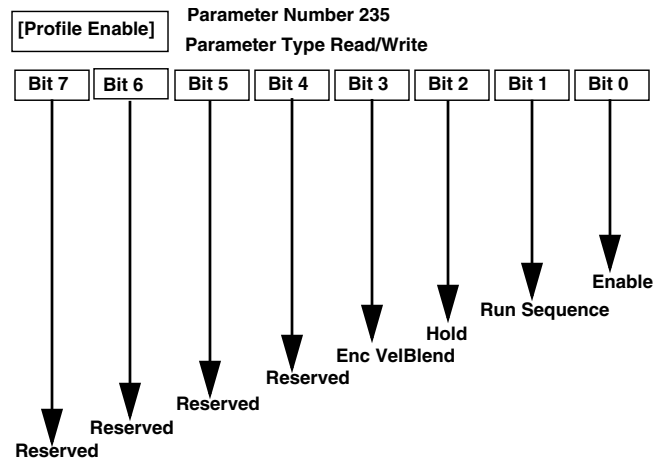
Feedback device is **Encoder:**

**Parameter #64** [Fdbk Device Type] is set to a value of 2.



## Profile Command & Control

Once a profile is properly configured, a command sequence is initiated by setting the first two bits of the **Profile Enable parameter #235**.



**Bit #0** (the first bit) sets the *Home position* and initializes the Profile sequence.

The **home position** is required only for the **Home End Action** and proper display of the Units Traveled parameter output #246. The Home End Action will be discussed in further detail in the Encoder section.

**Transitioning - Bit #1** (the second bit), actually initiates the profile sequence.

Both bits 0 & 1 must be set to initiate a sequence.

Setting the Run Sequence bit 1 will not start the profile if the Enable bit 0 is clear. Setting the Enable bit will initialize speed profiling and set the Home position, but the sequence of steps will not begin until the Run Sequence bit 0 (first bit) is set.

**IMPORTANT:** Parameter 235 (*Profile Enable*) is independent of the Drive Start/Stop control.

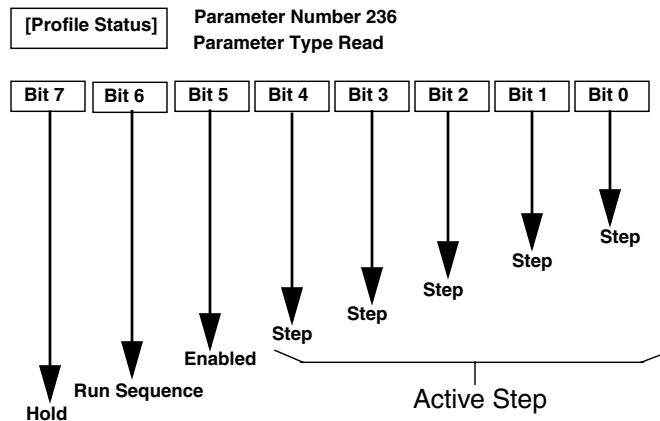
Bit 1 (Run Sequence) of parameter #235 must be toggled *in addition to* issuing a **Drive Start** command for Speed Profiling to operate.

Setting the **Hold Bit** (bit #2) will prevent a sequence from incrementing to the next step.

### Sequence State Status

Once the sequence has been initiated the state of the sequence will be reflected in the **Profile Status parameter #236**.

The lower 5 bits will tell us which state the control is commanding. You will observe bit 0 set for 10 seconds in Step 1. It will then clear and bit #1(second bit) will be set for 10 seconds, indicating Step #2.



If there were more steps, the first five bits (bits 0-4) of parameter 236 would reflect the present commanded step as a binary value.

Bits #5 and #6 of the status word, reflect the present state of the profile **Enable bit #0** and the **Run Sequence bit #1** of the command word (Profile Enable P235).

The Run Sequence bit is latched while the Enable bit is Not.

This means that once a sequence has begun, and the Run Sequence bit 1 (of P235) has been set, clearing of the Sequence bit will be ignored because it is latched.

### Beginning a Sequence

At this point, the system should be ready to run the Speed Profile program. To begin Profile Execution;

1. Set the Enable bit #0 (1st bit) of parameter #235.
2. Press the Green Button (On HIM or GPT terminal) to start the drive.
3. Set the Run Cycle bit #1 of the Profile Enable parameter #235 to execute profile control.

## Using the TB3 Inputs













The digital inputs of the L Option Card can be used with the speed profile control. Two input modes were added specifically for this purpose, modes #31 and 32.

Mode #31 makes six inputs available for controlling transition from one speed profile step to another.

Mode #32 duplicates some of the command functions of the Profile Enable parameter #235.

These L Option input modes can be selected by adjusting the value of parameter #116. Anytime the value of parameter #116 is changed the system should be reset, or the power to the control board should be cycled.

**Figure 9.10**  
**L Option Modes for Profiling**

		[L Option Mode]	
TB3		31	32
19		Step Trigger	Start
20		Not Stop Fault Clear	Not Stop Fault Clear
21		Common	Common
22		Step Trigger	Step Trigger
23		Step Trigger	Step Trigger
24		Not Ext Flt	Not Ext Flt
25		Common	Common
26		Step Trigger	Profile Enable
27		Step Trigger	Run Sequence
28		Step Trigger	Step Hold
29		Common	Common
30		Enable	Enable

### Step Transitions

Entering a value of 2 into any given **Step Type** parameter, defines the step as a TB3 input step.

When a step is defined as an input step, its Step Value parameter will associate a particular input terminal with that step.

In **mode #31** six inputs are available for step transitions.

When the Step Value parameter;

- = 0, TB3 Terminal #22 is selected
- = 1, TB3 Terminal #23 is selected
- = 2, TB3 Terminal #19 is selected
- = 3, TB3 Terminal #26 is selected
- = 4, TB3 Terminal #27 is selected
- = 5, TB3 Terminal #28 is selected

In mode #32, only two inputs are available for step transitions.

When the Step Value parameter;

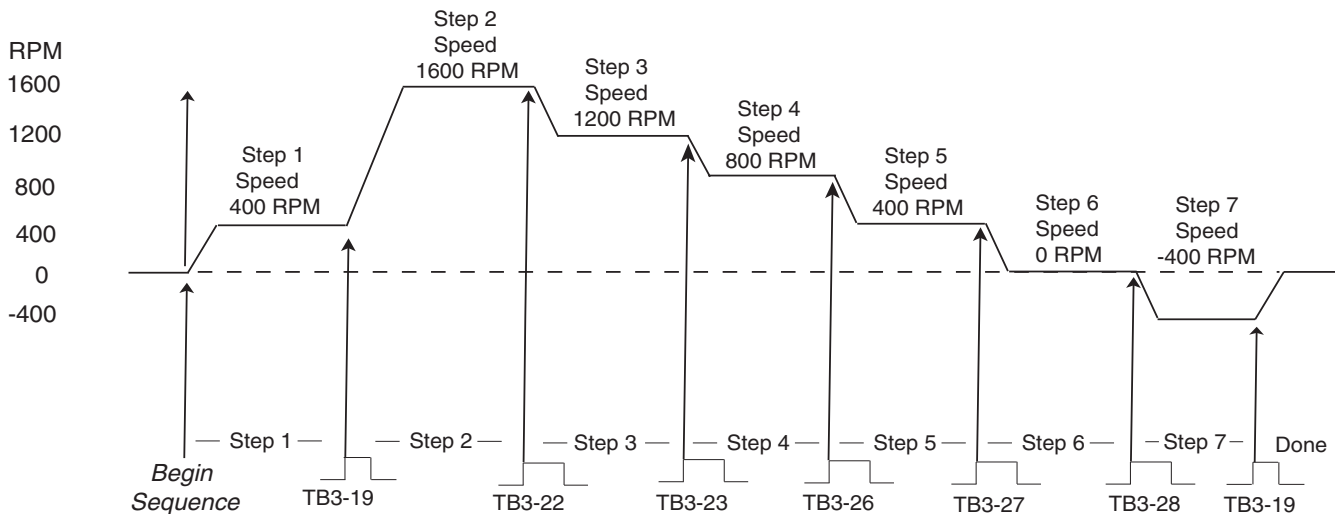
= 0, TB3 terminal #22 is selected

= 1, TB3 terminal #23 is selected

When an input step is executed it will command the Step Speed until the associated TB3 input is true.

When the associated input goes high, the Control will move to the next step.

**Figure 9.11- Input Step Transitions  
Motor Speed P81**



The example in Figure 9.11 shows a profile sequence utilizing Input Mode #31 to control transitions from one step speed to the next.

Since there are 16 steps and a maximum of 6 inputs available for use, multiple steps can reference the same digital inputs.

**Note:** When two steps reference the same input you must make certain they are not adjacent to each other. Note that step 1 and step 7 are both utilizing the same input terminal #19.

For Example: If Step 1 and Step 2 referenced the same input, the profile control would command Step 1 speed until it saw the input go true. Upon entering Step 2, it would see the same input high and immediately (12.5 ms) go to Step 3.

### Using Mode #32

Digital input mode #32 duplicates the function of the first three bits of the Profile Enable command parameter #235 to determine the command state of the Profile Control. It is best to **clear** the **Profile Enable** command parameter #235 when controlling Profile operation via input mode 32 to avoid unwanted interactions.

The three profile control TB3 inputs are or'ed with the Profile Enable command parameter #235 to determine the command state of the Profile Control.

Setting the **Profile Enable input** terminal (TB3-#26) will initialize the profile control, and set the current motor position as the Home position. This setting of the Profile Enable bit will be reflected in the Profile status parameter (P236 bit #5).

Setting the **Start input terminal** TB3- #19 will start the drive. This is the same as pressing the green start button on a HIM terminal.

Setting the **Run Cycle input** terminal TB3- #27 will initiate a Profile Sequence and will be reflected in the Status parameter P236 bit #6.

When the profile has completed an entire step sequence this input (Run Sequence #27) will have to be cleared and toggled high again to begin another sequence.

### **Input Step Hold**

Setting the **Step hold input** terminal TB3-#28 will prevent the profile from continuing to the next step. When the hold input is released (cleared) it will continue to the next state.

Two input terminals, #22 and #23 are available for controlling step transitions if desired.

### **Input End Actions**

When an input End Action is selected, the profile Control will command the End Action speed (P239) until the selected TB3 input goes high. The control will then command zero speed.

An Input End Action is selected by entering a value of 2 in the End Action parameter #238. The input terminal used to trigger the zero speed command is selected by parameter #241.

The step trigger inputs are the only valid choices for signaling the end of the Profile Sequence. Remember, six inputs are available in Mode #31, but only two inputs are valid in Mode #32.

## **Encoder Steps**

Setting a **Step Type** parameter to a value of 3, defines it as an **Encoder Step**.

### **Adjustable Encoder Step Units**

Adjustment of the **Counts Per Unit parameter** allows you to define the Units for Encoder Steps in increments that are meaningful for a particular application.

For Example: An application translates four motor shaft revolutions via gearing, into one linear foot of movement. The Counts Per Unit parameter could be adjusted so that the Encoder Step Value parameters are entered in units equating to one foot.

### **Encoder Units and the Counts Per Unit Parameter**

The rotational distance of each encoder **step unit** is determined by Counts Per Unit parameter #245.

When determining the value of the Counts Per Unit parameter, it is important to understand that a typical encoder produces a value that is 4 times greater than the encoder PPR rating.

This is because the drives are designed to utilize quadrature encoders. With a quadrature encoder, the counter will increment on the rising edge of each of the four input signals (A,  $\bar{A}$ , B,  $\bar{B}$ ).

This can be verified by resetting the drive or cycling power to clear the encoder position feedback parameters #227 & #228. Rotate the shaft one revolution and observe the value of parameter #227. This should be four times greater than the value of the encoder PPR parameter #8.

### **Step Rotation Distance In Motor Shaft Revolutions**

To define all encoder Step Value parameter units as graduated in whole revolutions, set the Count Per Unit parameter (CPU) equal to 4 x the PPR parameter #8.

For Example: For a single revolution in a drive with a 1024 PPR encoder;

$$\text{CPU (P245)} = 4 \times 1024 \text{ (P8)} = 4096$$

With the CPU parameter set, entering a value of 100 in the **Step 1 Value** parameter #250, will cause the profile control to command the **Step 1 Speed** until the motor has turned 100 revolutions.

$$\text{P249 Step 1 Speed} = 1726$$

$$\text{P250 Step 1 Value} = 100.0 \text{ units (revs)}$$

$$\text{P251 Step 1 Type} = 3 \text{ (Encoder)}$$

To have one encoder unit equal two motor revolutions:

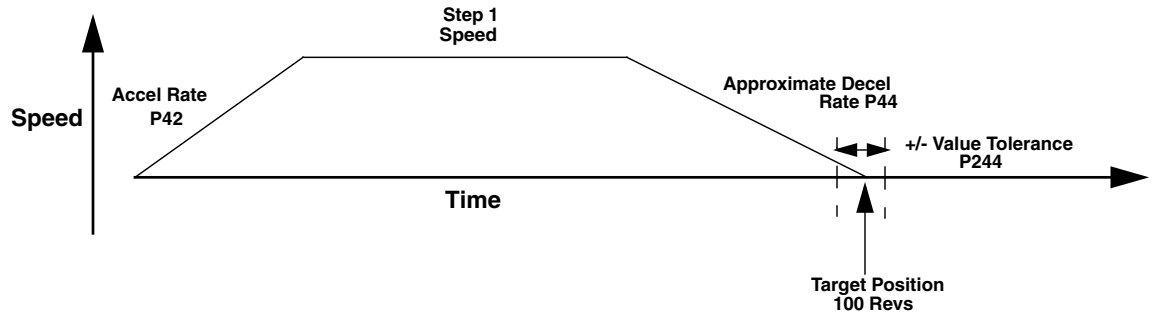
$$\text{CPU (P245)} = 2 \text{ revs} \times (4 \text{ PPR}) = 8 \times \text{PPR (P8)}$$

To have one value parameter unit equal 1/2 revolution;

$$\text{CPU (P245)} = 1/2 \times (4 \text{ PPR(P8)}) = 2 \times \text{PPR (P8)}$$

Step Value parameters can be entered in 1/10th unit increments.

**Figure 9.12**  
**Example: Single Encoder Step1**



### Determining the End of an Encoder Step

The Value Tolerance parameter #244 is used as a hysteresis band for determining the End of Step position.

The motor shaft must be at the target position within the +/- value tolerance (P244) counts for eleven consecutive update cycles (Approx 138 ms) before control will continue to the next step.

Should the motor overshoot the target, the profile command will adjust in the opposite direction, causing the shaft to back up.

If this overshoot is unacceptable, the Error Trim Gain (P237) can be set to a lower value (less than 2.0) to eliminate this. The Error Trim Gain parameter is discussed in detail later in this chapter.

### “At Encoder Position” Output Relay #4 signal

The #4 Output relay is reserved for identification of the encoder step position.

When the shaft has remained within the target position tolerance for approximately 50 ms, the control will set the Output Relay #4 to identify the motor shaft as being at the programmed Step Target position.

If the next step is an Encoder step, the output will be cleared when beginning this next step. If the next step is not an encoder step, the relay will be left set.

### Step Hold in Encoder Mode

The **Hold bit** can be set either by writing the third bit of the Profile Enable parameter, or by setting the L10 TB3 input terminal #28 in Mode 32.

When the hold bit is set, the Profile Control will continue to the step target. With the Step Hold bit set, the control will not proceed to the next step. The control will remain active and maintain the target position until the hold bit is cleared. When released (hold bit cleared) it will continue to the next step.

### Decelerating to Position and the Error Trim Gain

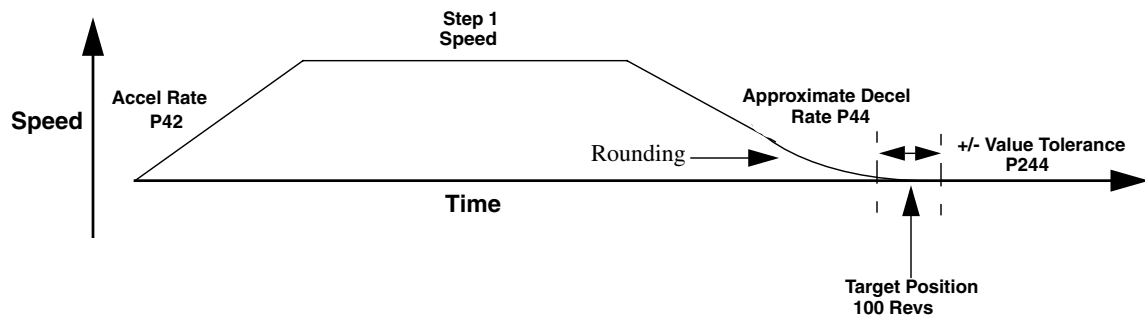
The Error trim parameter is actually a Dynamic Gain Limit, for those familiar with position control. This gain comes into play only when the shaft is nearing the target. As the Error gets very small, the gain increases to allow fine adjustment.

When the Trim Gain parameter is above a value of 2.0, the profile control will decelerate as it approaches the target at approximately the programmed Decel rate (P44).

If the shaft overshoots the target area it will back up. If this is unacceptable, the Error Trim Gain parameter can be lowered to eliminate this overtravel.

As the value of this parameter is lowered it will begin to “round off” the end of the decel ramp (Fig. 9.13). The end of the target approach can be made as “smooth” as desired using this method.

**Figure 9.13**  
**Example: Encoder Step Trim**



Continuing to lower the trim gain value will cause this rounding to begin earlier in the Decel ramp. This will also cause the time to target position to extend longer.

### Step Position Error

The control will position the motor within the tolerance on each step before proceeding to the next step. The actual rotor position may be slightly forward or behind the exact target and still be within range. Increasing the tolerance parameter value will enlarge this range.

When the next step calculates a target, it uses the actual position the new step begins at.

### Repeating Profile Sequences

If a **Goto End Action** is selected the position error will continue to accumulate over multiple sequences. Over time the accrued error could be significant.

If a **Home End Action** is selected, the error of a single sequence will *Not* accumulate over multiple sequences. The rotor will return to the same position it was in when the Profile enable bit was first set. As long as the enable bit is set, the control will retain this as its home position. Additional sequences can be started by toggling the **Run Sequence bit**.

### Velocity Blend Mode

Encoder mode applications which don't require great precision can utilize the **Velocity Blend** mode to switch from one step velocity to another. In this blend mode, control will not demand that the motor rest at zero speed for eleven update intervals before continuing to the next step as illustrated in Figure 9.14.



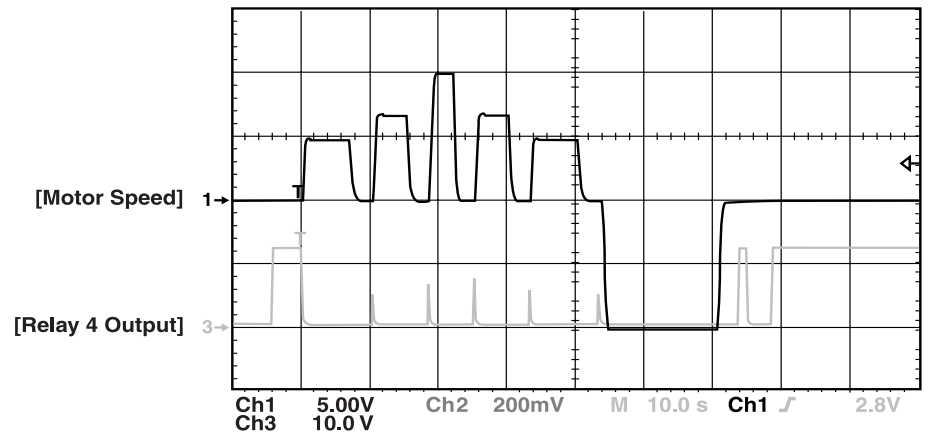
This is useful when using the encoder to replace limit switches for controlling the commanded speed. Keeping the commanded velocity from going to zero speed for fine positioning, will reduce the time between encoder steps. This subsequently reduces the overall cycle time.

The blend mode will reduce the position accuracy since the drive may be moving at a relatively fast rate. The encoder sample interval is fixed at 12.5 ms.

The control will not backup to maintain a position. It will automatically continue to the next step when the position is at or beyond the target. Any errors would accumulate throughout the sequence.

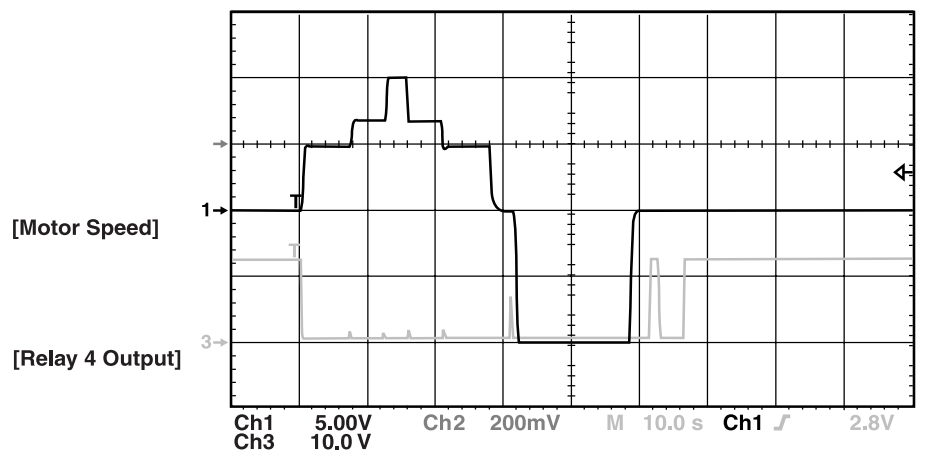
**Figure 9.14**  
**Velocity Blend Mode Example**

**Step Example Without Velocity Blend**  
[Profile Enable] xxxx0011



Notice that each step is a precise movement and the control brings the motor to zero speed at the end of each step. When the step is within tolerance value, the relay output activates. Once the next step is initiated, the relay opens (out of tolerance).

**Step Example Using Velocity Blend Mode**  
[Profile Enable] xxxx1011



Notice that the step velocities are “blended” together in this mode. The position accuracy at each step is limited, but with an encoder home end action, the starting position is very accurate.

**Notes**

## Using the Function Block

### Chapter Objectives

Chapter 10 provides information for helping you to use the function block that is included with the 1336 IMPACT drive.

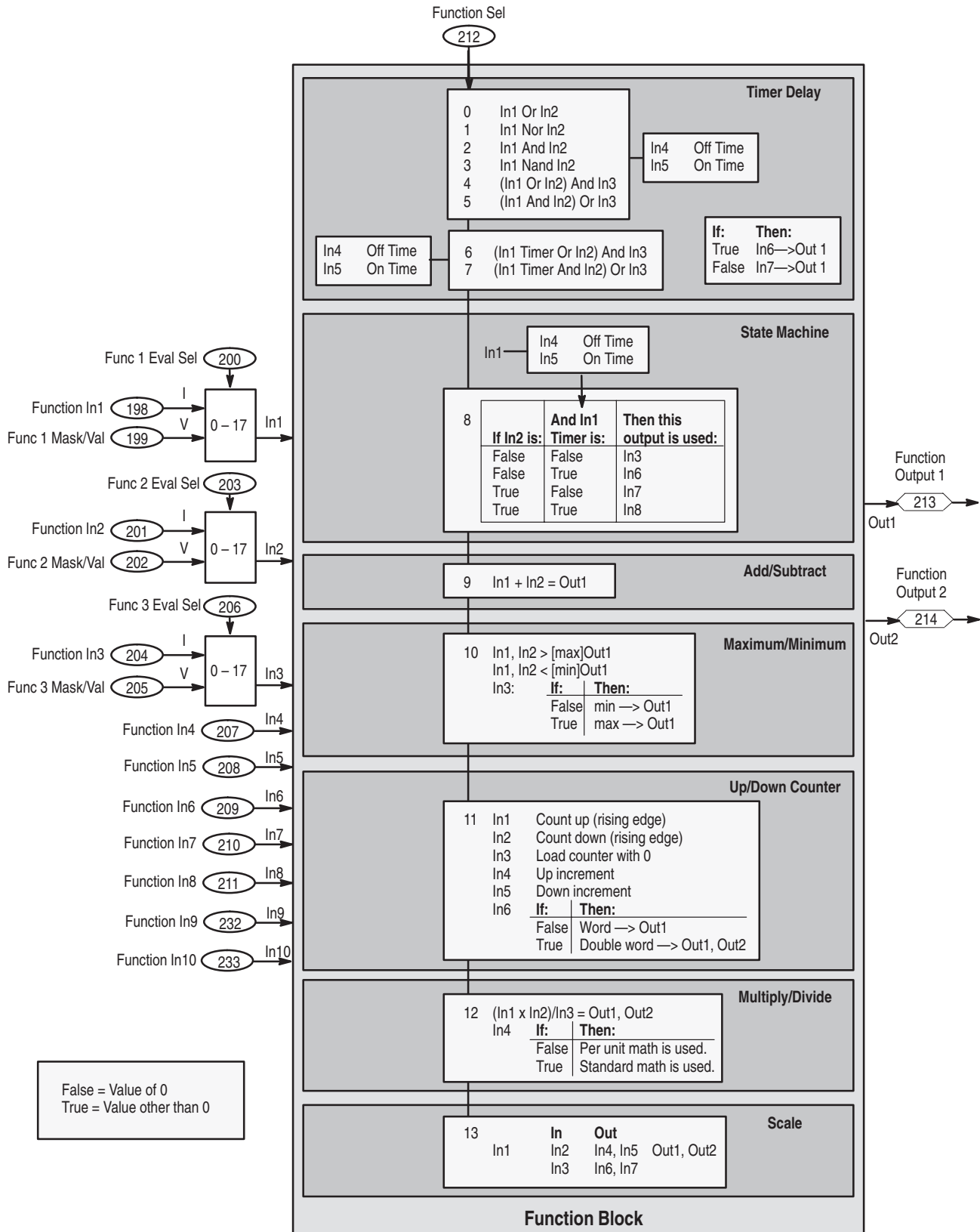
<b>This topic:</b>	<b>Starts on page:</b>
An overview of function blocks	10-1
Evaluating the inputs	10-4
Using the timer delay function	10-5
Using the state machine function	10-8
Using the add/subtract function	10-10
Using the maximum/minimum function	10-12
Using the up/down counter function	10-14
Using the multiply/divide function	10-18
Using the scale function	10-20
Using the hysteresis function	10-23
Using the band function	10-26
Using the logical add/subtract function	10-26
Using the logical multiply/divide function	10-27

### What is a Function Block?

A function block is a group of parameters that work together to add flexibility to the 1336 IMPACT drive. The function block that is provided with the 1336 IMPACT drive lets you set up a timer delay, state machine, multiply/divide, add/subtract, scale, an up/down counter, or a maximum/minimum function by using a combination of 17 parameters. Because these functions use the same parameters, you can only use one of the function blocks (such as the timer delay) in your application.

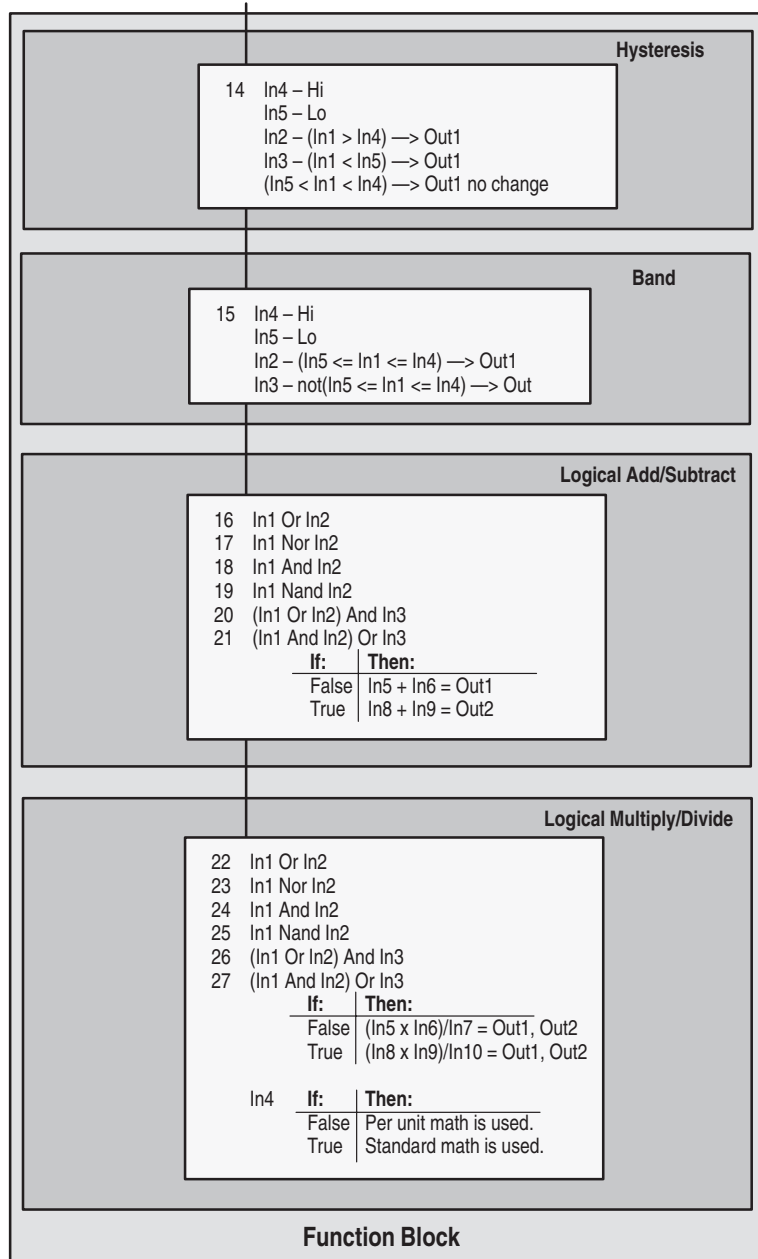
Figure 10.1 provides an overview of the function block.

**Figure 10.1**  
**Function Block Overview**



Continued on Next Page

Continued from Previous Page



## Evaluating the Inputs

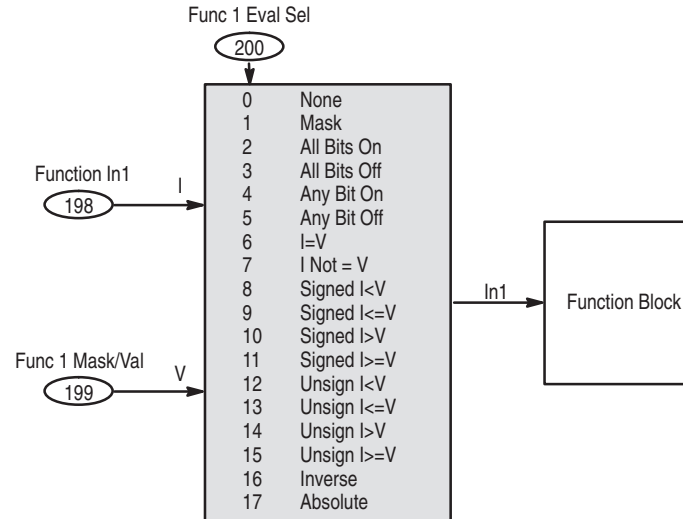
*Func 1 Eval Sel* (parameter 200), *Func 2 Eval Sel* (parameter 203), and *Func 3 Eval Sel* (parameter 206) let you select how you want to evaluate the corresponding input. You have the following options:

To:	Value:
Pass the value directly through to the function block	0
Mask the value (logical AND the input value with a value)	1
Send a true value when <b>all</b> bits that are set in the mask are <b>on</b> in the input value	2
Send a true value when <b>all</b> bits that are set in the mask are <b>off</b> in the input value	3
Send a true value when <b>any</b> bit that is set in the mask is <b>on</b> in the input value	4
Send a true value when <b>any</b> bit that is set in the mask is <b>off</b> in the input value	5
Send a true value when the input value is equal to the value of <i>Func x Mask/Val</i> (parameter 199, 202, or 205)	6
Send a true value when the input value is not equal to the value of <i>Func x Mask/Val</i> (parameter 199, 202, or 205)	7
Send a true value when the signed input value is less than the value of <i>Func x Mask/Val</i> (parameter 199, 202, or 205)	8
Send a true value when the signed input value is less than or equal to the value of <i>Func x Mask/Val</i> (parameter 199, 202, or 205)	9
Send a true value when the signed input value is greater than the value of <i>Func x Mask/Val</i> (parameter 199, 202, or 205)	10
Send a true value when the signed input value is greater than or equal to the value of <i>Func x Mask/Val</i> (parameter 199, 202, or 205)	11
Send a true value when the unsigned input value is less than the value of <i>Func x Mask/Val</i> (parameter 199, 202, or 205)	12
Send a true value when the unsigned input value is less than or equal to the value of <i>Func x Mask/Val</i> (parameter 199, 202, or 205)	13
Send a true value when the unsigned input value is greater than the value of <i>Func x Mask/Val</i> (parameter 199, 202, or 205)	14
Send a true value when the unsigned input value is greater than or equal to the value of <i>Func x Mask/Val</i> (parameter 199, 202, or 205)	15
Send an inverted value through to the function block	16
Send an absolute value through to the function block	17

► You should set up *Func 1 Eval Sel*, *Func 2 Eval Sel*, and *Func 3 Eval Sel* before setting up the other parameters. This adjusts the units used for the *Function In x* and *Func x Mask/Val* parameters.

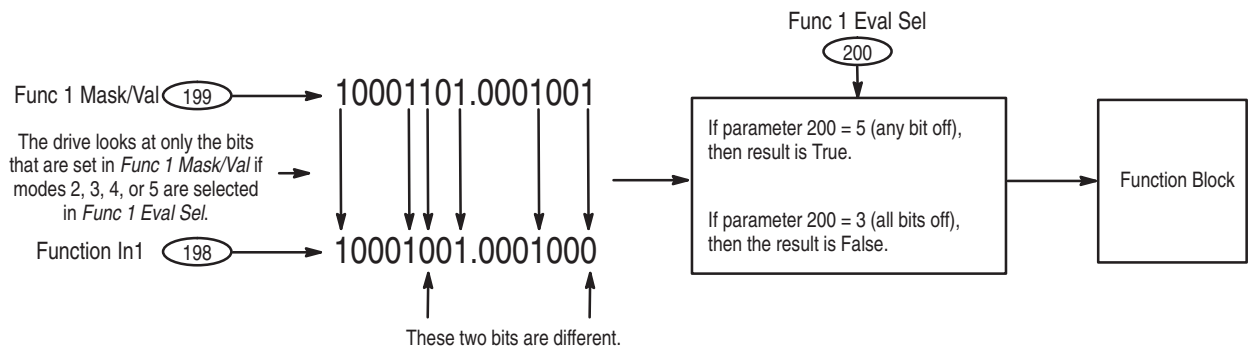
Figure 10.2 shows how the input parameters for function input 1 work together. The input parameters for function inputs 2 and 3 work in the same manner.

**Figure 10.2**  
**Input 1 Parameters for the Function Block**



For example, if *Function In1* (parameter 198) is 10001001.0001000, *Func 1 Mask/Val* (parameter 199) is 10001101.0001001, and *Func 1 Eval Sel* (parameter 200) is set to 5 (any bit off), then a value of true is passed to the function block. If *Func 1 Eval Sel* is set to 3 (all bits off), then a value of false is passed to the function block. Figure 10.3 shows how this works.

**Figure 10.3**  
**Example of Function Input 1 Parameters**



If you want to pass the value of *Function In1* directly to the function block without evaluating it, set *Func 1 Eval Sel* to 0.

*Function In4* (parameter 207), *Function In5* (parameter 208), *Function In6* (parameter 209), *Function In7* (parameter 210), and *Function In8* (parameter 211) provide additional input values.

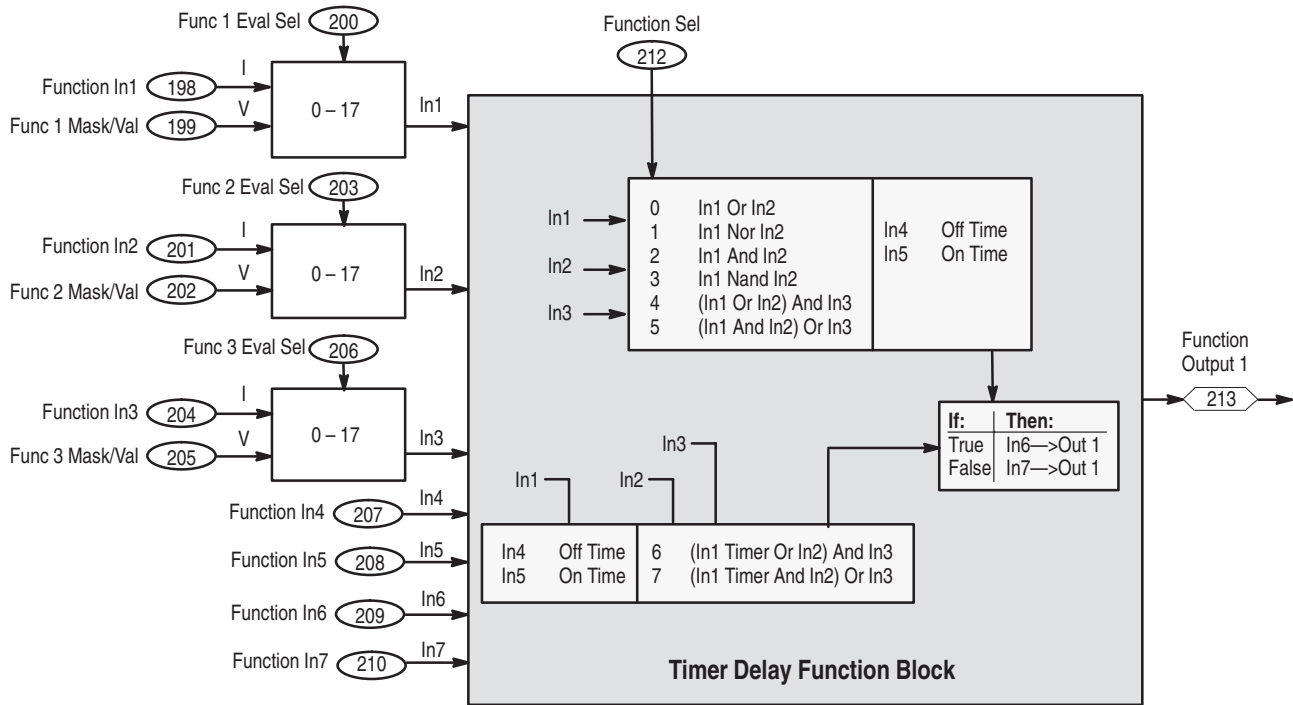
## Using the Timer Delay Function

You can use the function block to set up a timer delay. You can choose how to evaluate the inputs and when you want to apply the timer by using *Function Sel*.

► Regardless of the option you choose, the timer off event cannot happen until after your timer on event occurs.

Figure 10.4 shows the parameters that are used for the timer delay function and how these parameters are evaluated.

**Figure 10.4**  
**Timer Delay Function Block**

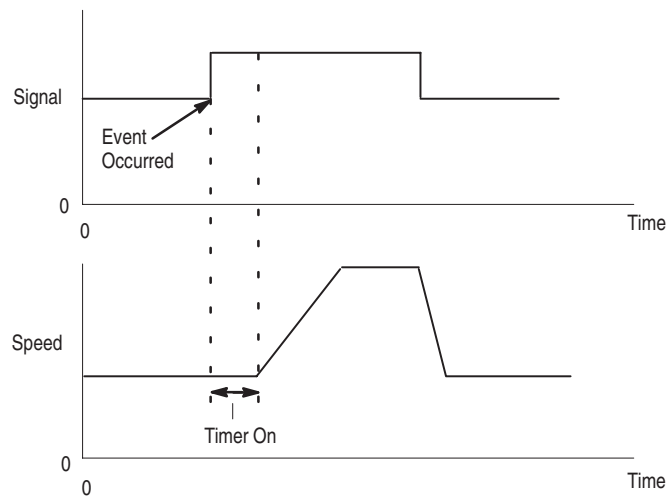


As an example, you could use the timer delay function to set up a delayed start with a ramp up to speed function. When the L Option receives start input, there is a delay before the start command is sent to the motor. This delay is specified in *Function In5* (parameter 208) as a time in minutes. For this example, *Function In5* is set to 0.25 minutes, which is 15 seconds. When the time expires, the motor speed ramps up to the specified speed. When the start is removed or a stop command is issued, the stop command is sent to the drive and the ramp is disabled, causing a current limit stop to zero speed.

This example is shown in Figure 10.5.

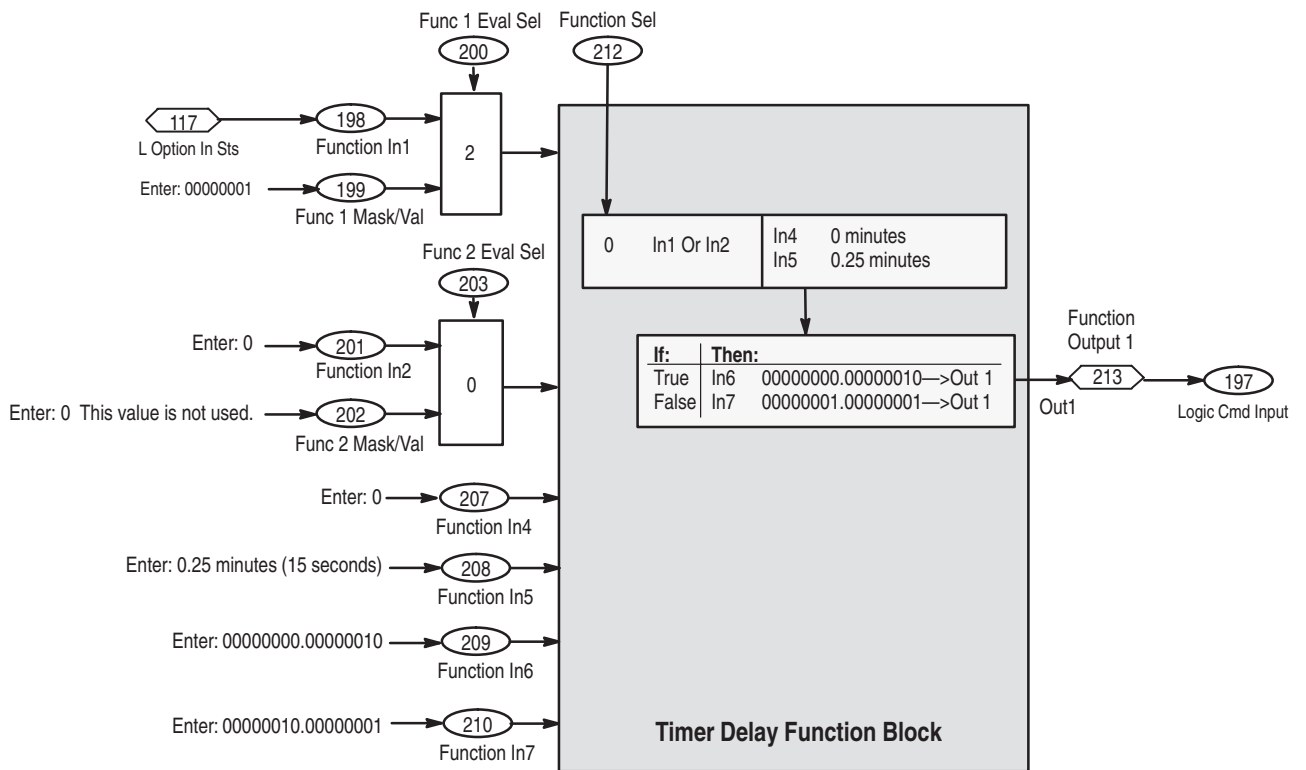


**Figure 10.5**  
**Delayed Start with a Ramp to Speed Example**



To set up this application, you need to enter the values shown in Figure 10.6.

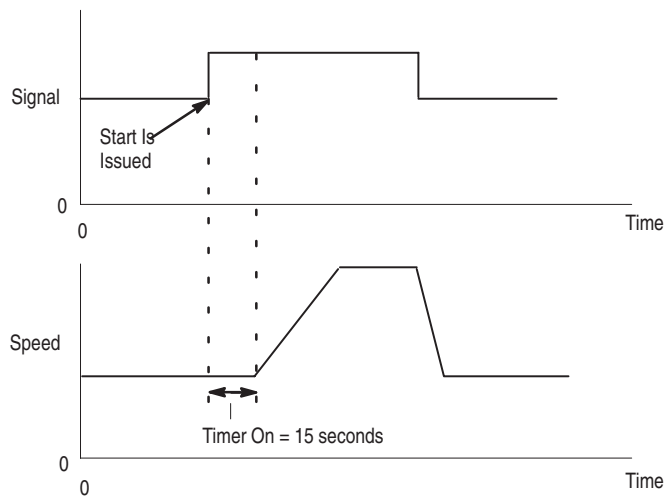
**Figure 10.6**  
**Timer Delay Function Block**



Enter 0 for Function In3 (parameter 204), Func 3 Mask/Val (parameter 205), Func 3 Eval Sel (parameter 206) and Function In8 (parameter 211) as these parameters are not used for this function block.

This works as shown in Figure 10.7.

**Figure 10.7**  
**Delayed Start with a Ramp to Speed Example**

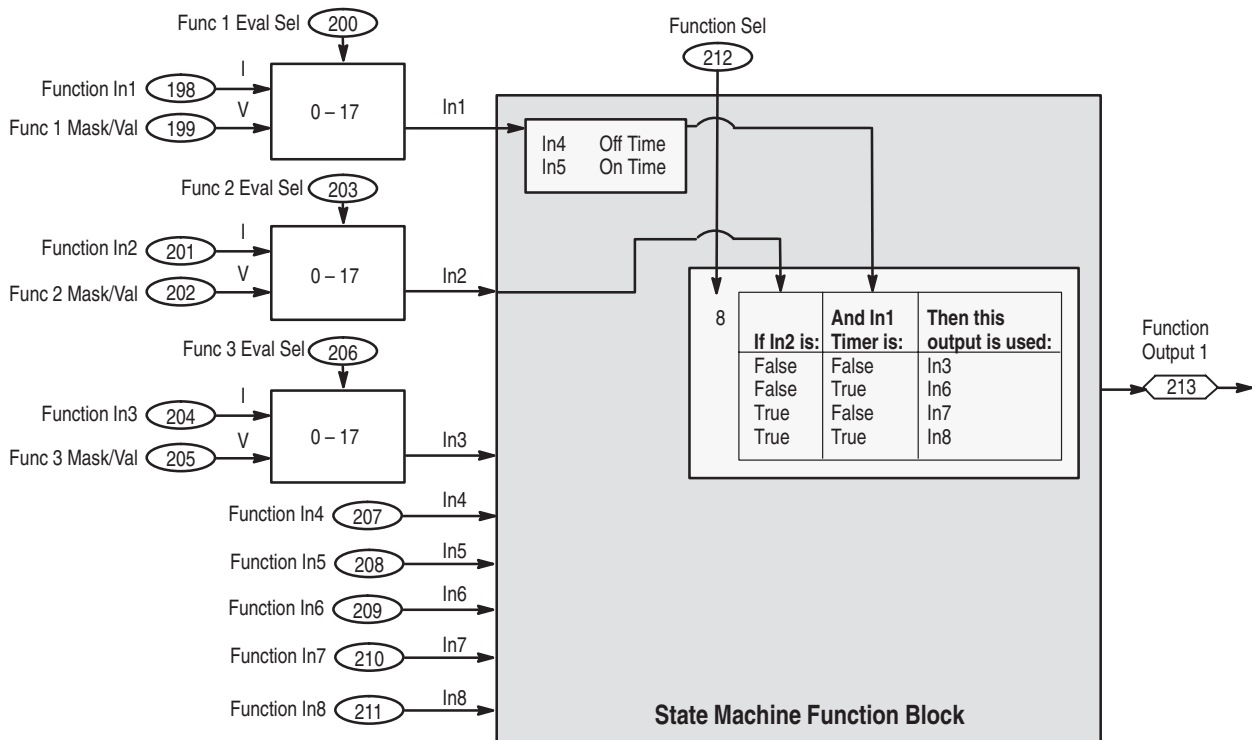


In addition, *Start/Jog Mask* (parameter 126) should be set to 11111110.11111111.

**Using the State Machine Function**

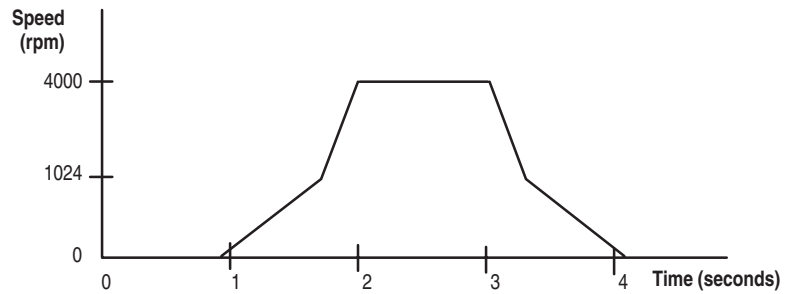
The state machine function lets you use a decision table to select which value to use for the output based on the values of In2 and a timer on In1. Figure 10.8 shows the state machine function block.

**Figure 10.8**  
**State Machine Function Block**



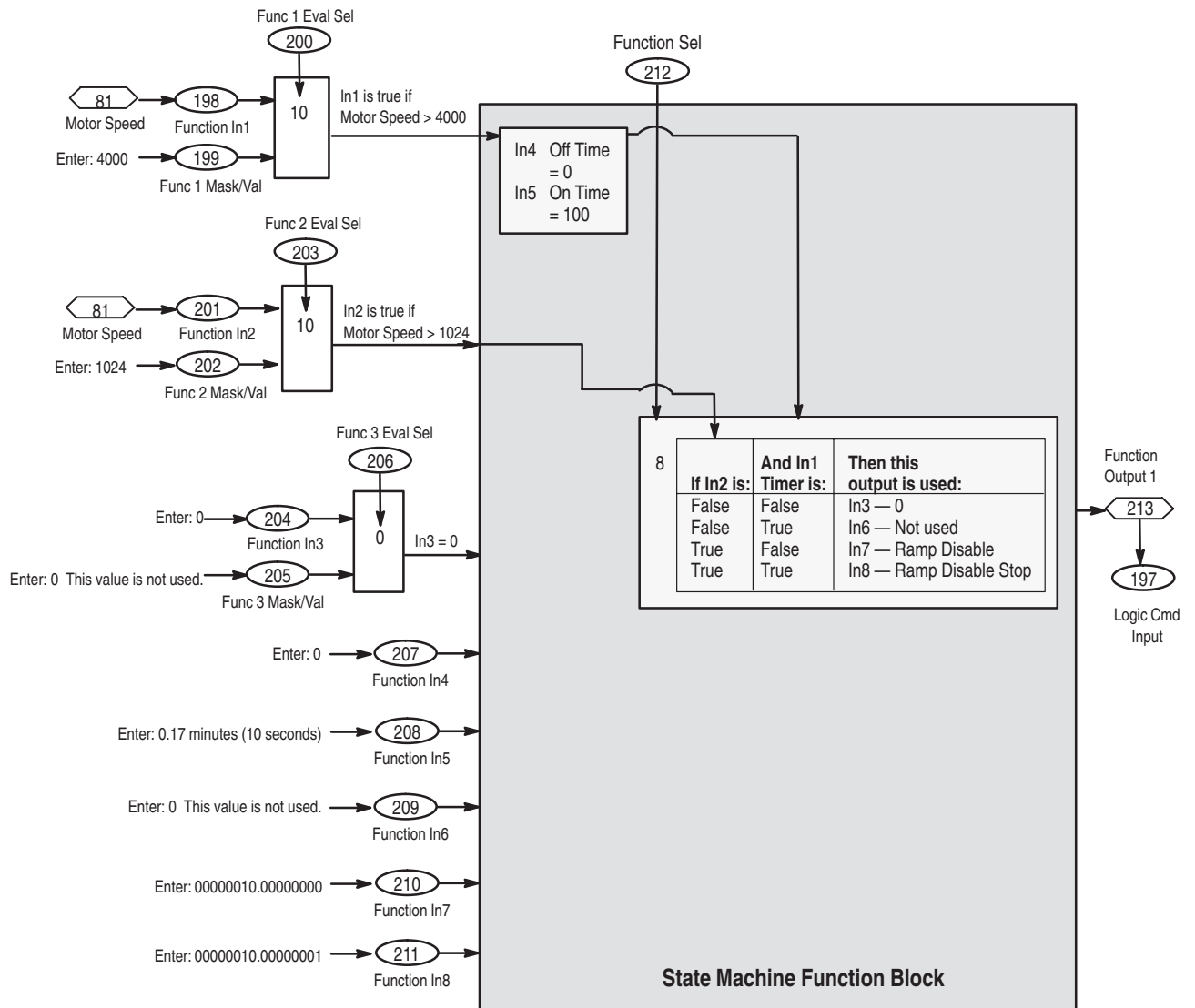
As an example, you could use the state machine function block to set up a speed profiler such as the one shown in Figure 10.9.

**Figure 10.9**  
**Speed Profiler Using the State Machine Function Block**



To set up the function block for this application, you would need to enter the values shown in Figure 10.10.

**Figure 10.10**  
**State Machine Function Block**



This works as shown in Figure 10.11.

**Figure 10.11**  
**Speed Profiler Using the State Machine Function Block**

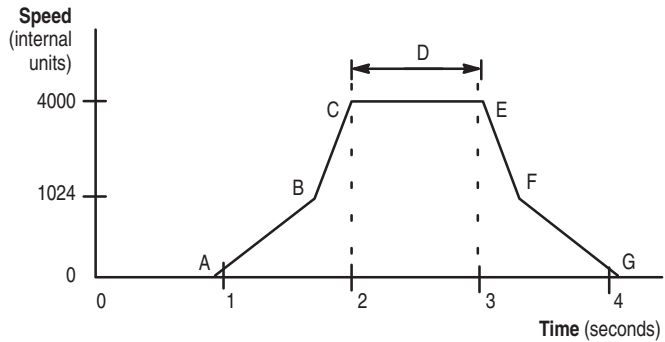
At point **A**, a start command has been received and the motor speed can begin to follow the specified acceleration ramp.

At point **B**, the motor speed has reached 1024 internal units. Because In2 (*Motor Speed* (parameter 81) > 1024) becomes true while In1 (*Motor Speed* > 4096) is still false, the state machine uses In7 (Ramp Disable) as the output sent to *Function Output1* (parameter 213) which is linked to *Logic Cmd Input* (parameter 197). The motor speed increases using the current limit.

At point **C**, In1 (*Motor Speed* > 4096) becomes true and the timer on function runs for 10 seconds (D) as specified by In5. After 10 seconds, the stop command becomes true, and the motor speed decreases using the current limit.

At point **E**, *Motor Speed* is less than 4096 so the drive is again using In7 (Ramp Disable). The stop is removed.

At point **F**, *Motor Speed* is less than 1024 and with both In1 and In2 being false, In3, which is 0, is used for *Function Output1*. The motor continues decelerating using the specified deceleration ramp.

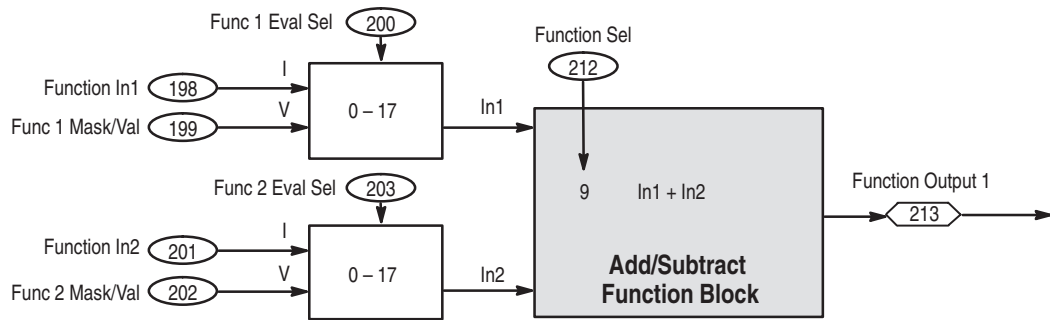


In addition, you need to set three other parameters for this example to work. *Speed Ref 1* (parameter 29) needs to be set to the base motor speed (4096 internal units). *Accel Time 1* (parameter 42) and *Decel Time 1* (parameter 44) both need to be set to 2 seconds.

**Using the Add/Subtract Function**

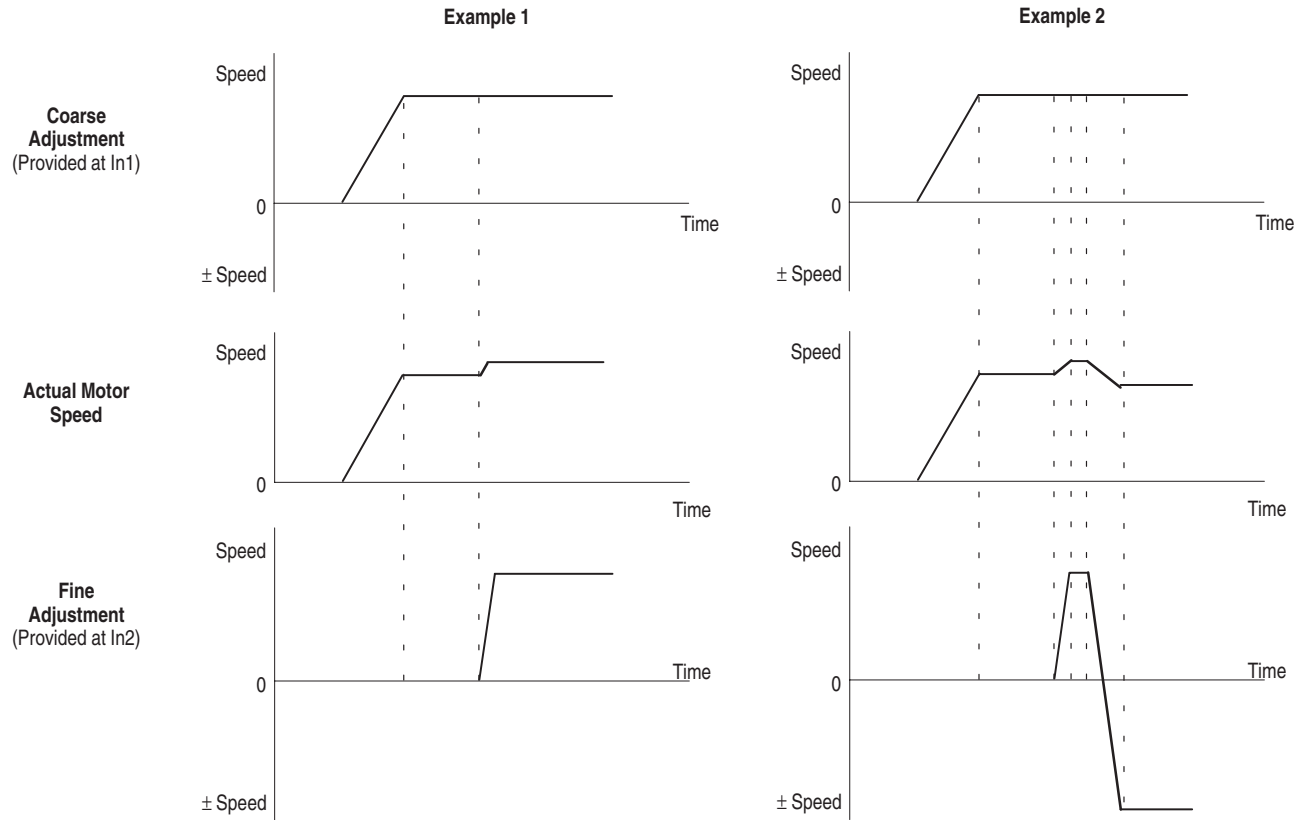
The add/subtract function adds the value of function input 1 to the value of function input 2 and places the result in *Function Output1* (parameter 213). Figure 10.12 shows the add/subtract function block.

**Figure 10.12**  
**Add/Subtract Function Block**



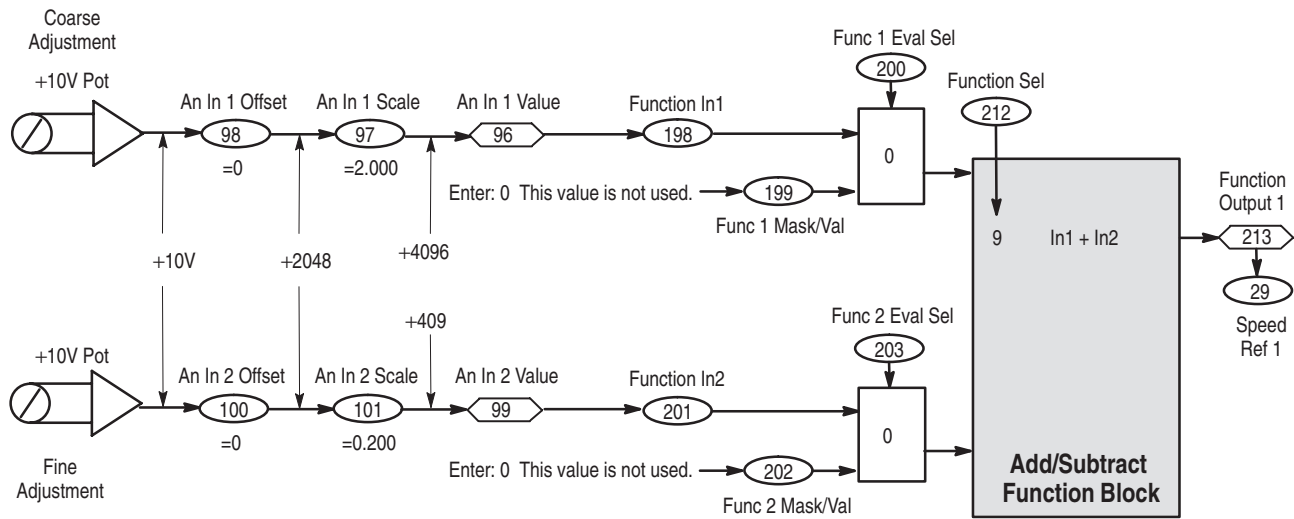
As an example, you could set up the add/subtract function block to provide fine and coarse adjustment to the speed reference as shown in Figure 10.13.

**Figure 10.13**  
**Examples of Fine and Coarse Adjustments in Speed**



For this example to work, link the analog input 1 parameters to *Function In1* (parameter 198) and the analog input 2 parameters to *Function In2* (parameter 201) as shown in Figure 10.14.

**Figure 10.14**  
**Example of an Add/Subtract Function Block**



Enter 0 for parameters 204 through 211 as these parameters are not used for this function block.

*An In 1 Value* (parameter 96) receives input from a  $\pm 10\text{V}$  pot. *An In 1 Offset* (parameter 98) is set to 0 because no offset is needed. The  $\pm 10\text{V}$  input is converted to  $\pm 2048$  internal drive units. *An In 1 Scale* (parameter 97) is set to 2 to scale the value to  $\pm 4096$ , which is  $\pm$ base motor speed. This input is passed to *Function In1* to use as the coarse adjustment.

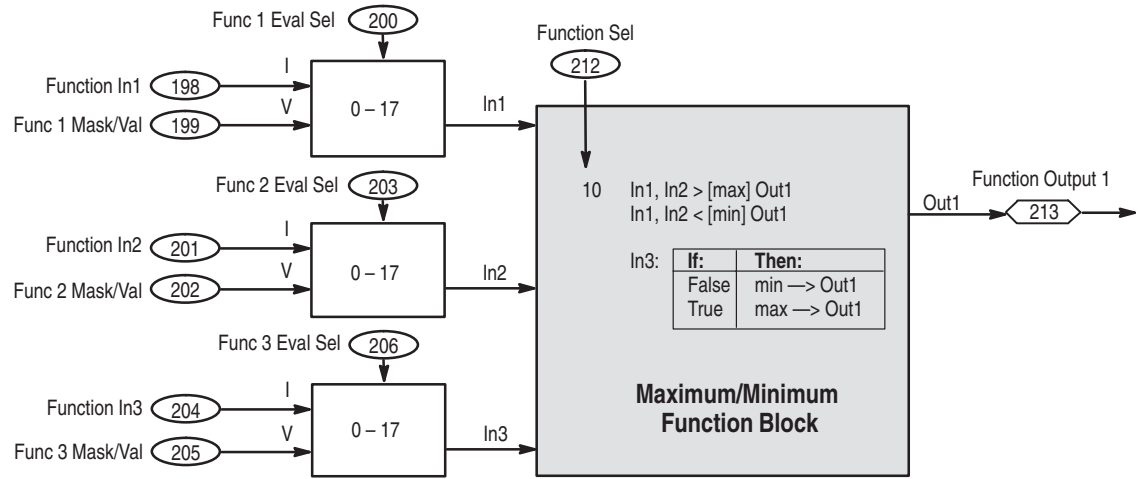
*An In 2 Value* (parameter 99) receives input from a 10V pot. *An In 2 Offset* (parameter 100) is set to 0 because no offset is needed. The 10V input is converted to 2048 internal drive units. *An In 2 Scale* (parameter 101) is set to 0.2 to scale the value to 409. This input is passed to *Function In2* to use as the fine speed adjustment.

In addition, you need to set bit 11, Bipolar Sref, in *Logic Options* (parameter 17).

## Using the Maximum/Minimum Function

The maximum/minimum function lets you select either the larger of two values or the smaller of two values. The maximum/minimum function block is shown in Figure 10.15.

**Figure 10.15**  
**Maximum/Minimum Function Block**

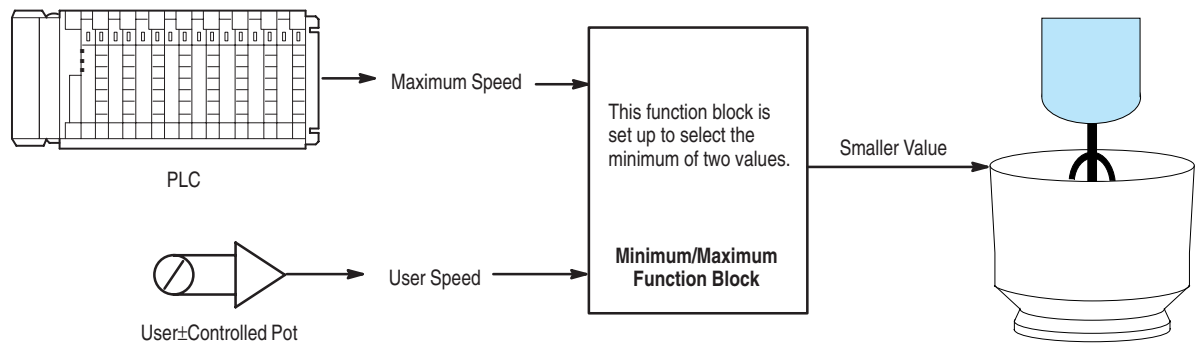


In1 is compared to In2. The value passed to *Function Output 1* (parameter 213) depends on In3.

If In3 is:	Then this value is passed to <i>Function Output 1</i> :
False	The smaller value
True	The larger value

As an example, you could use the maximum/minimum function block to make sure that the speed in a mixing process does not exceed a specified limit. Figure 10.16 shows this application.

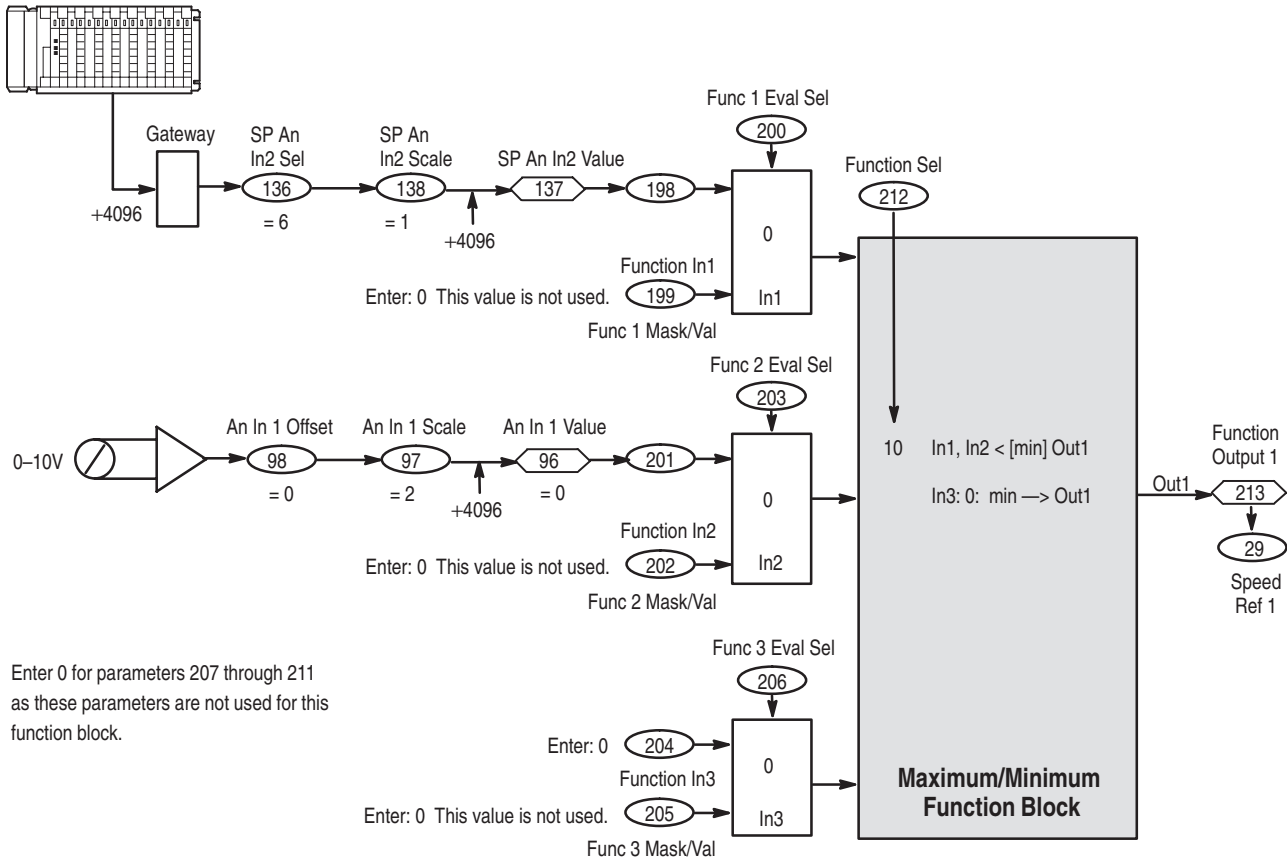
**Figure 10.16**  
**Example of a Mixing Process**



For this example, the PLC is used to monitor the mixing process. The user can control the speed of the mixing process, up to the maximum speed specified by the PLC. The maximum/minimum function block is used to select whichever value is smaller (the minimum): the speed specified by the PLC or the speed specified by the pot.

To set up the function block for this application, you would need to enter the values shown in Figure 10.17.

**Figure 10.17**  
**Maximum/Minimum Function Block**



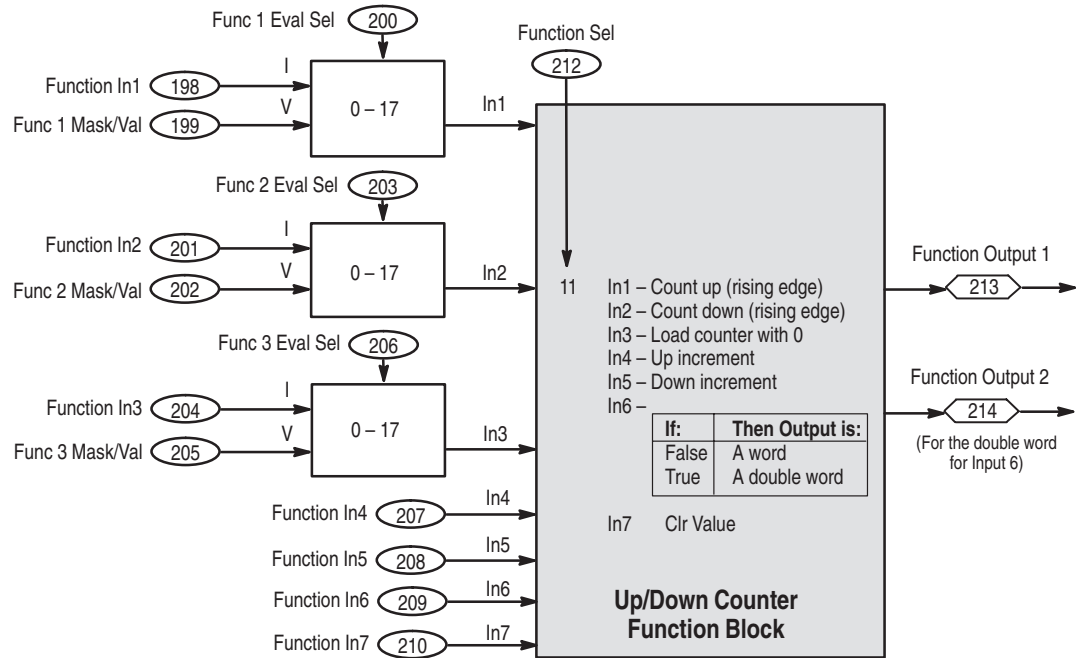
Enter 0 for parameters 207 through 211 as these parameters are not used for this function block.

**Using the Up/Down Counter Function**

The up/down counter function lets you increment or decrement a value. The up/down counter function block is shown in Figure 10.18.



**Figure 10.18**  
**Up/Down Counter Function Block**



When a rising edge occurs, on In1, the output is incremented by the value in In4, and on In2, the output is decremented by the value in In5. The output can be either a word or a double word.

If In6 is:	Then the output is:
False	A word value passed to <i>Function Output 1</i> .
True	A double word value with the high word passed to <i>Function Output 1</i> and the low word passed to <i>Function Output 2</i> .

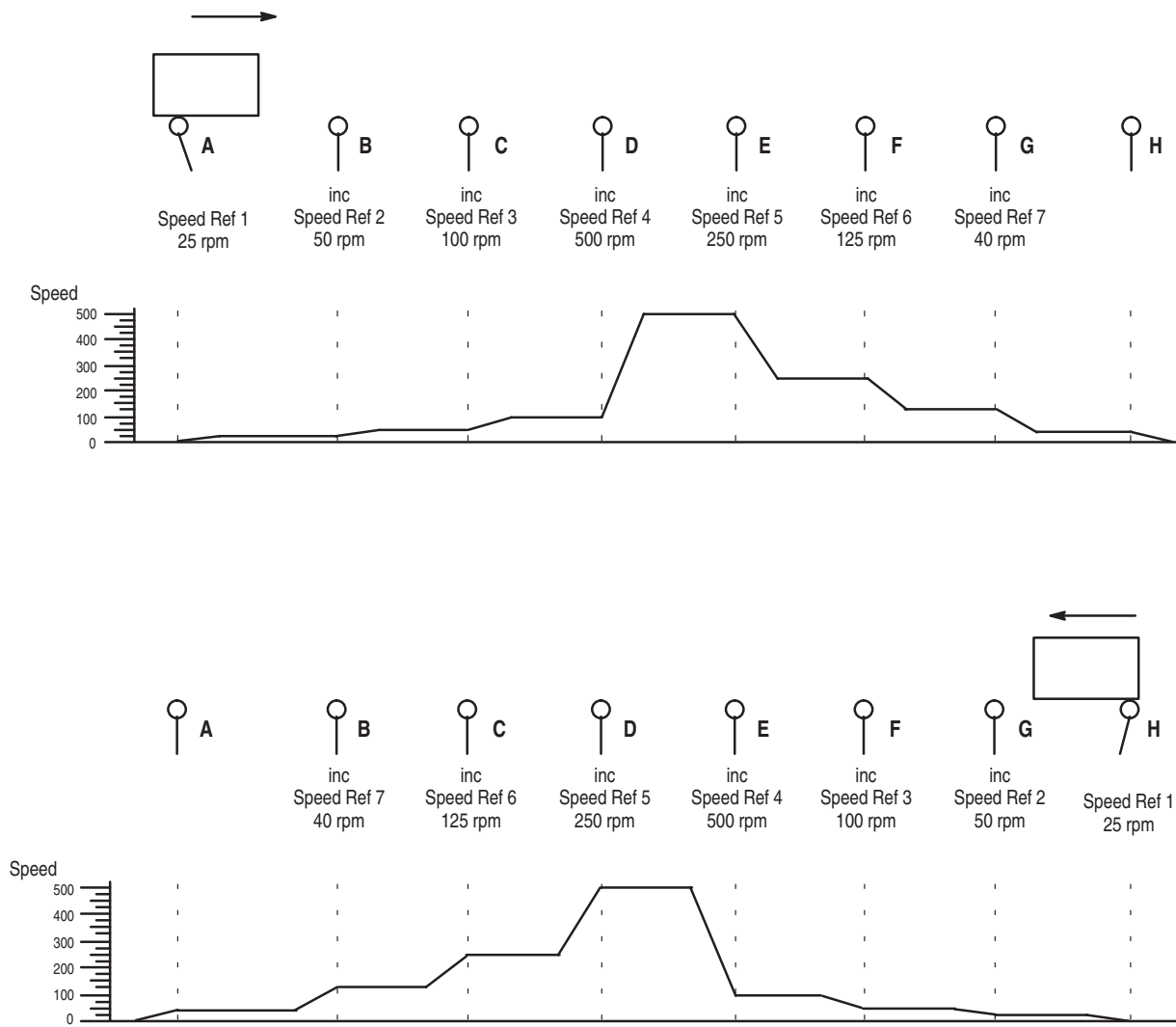
To clear the counter, set In3, which loads the counter with the In7 value. As long as In3 is set, the counter remains at the In7 value, even if In1 or In2 is toggling.

As an example of the up/down counter function block, you could create a shuttle. When you press the start button, a start forward command is sent to the drive, the shuttle begins to move from A to H, and the drive follows the first preset speed. As the shuttle passes each switch, the value of In1 is incremented and a new speed reference is used. The speed references are set using *Speed Ref 1* (parameter 29) through *Speed Ref 7* (parameter 36).

When the shuttle reaches relay H, then a stop command is issued and the value of In1 is decremented. When you press the start button again, a start reverse command is sent to the drive and the shuttle moves from H to A following the preset speeds as they are incremented by each switch.

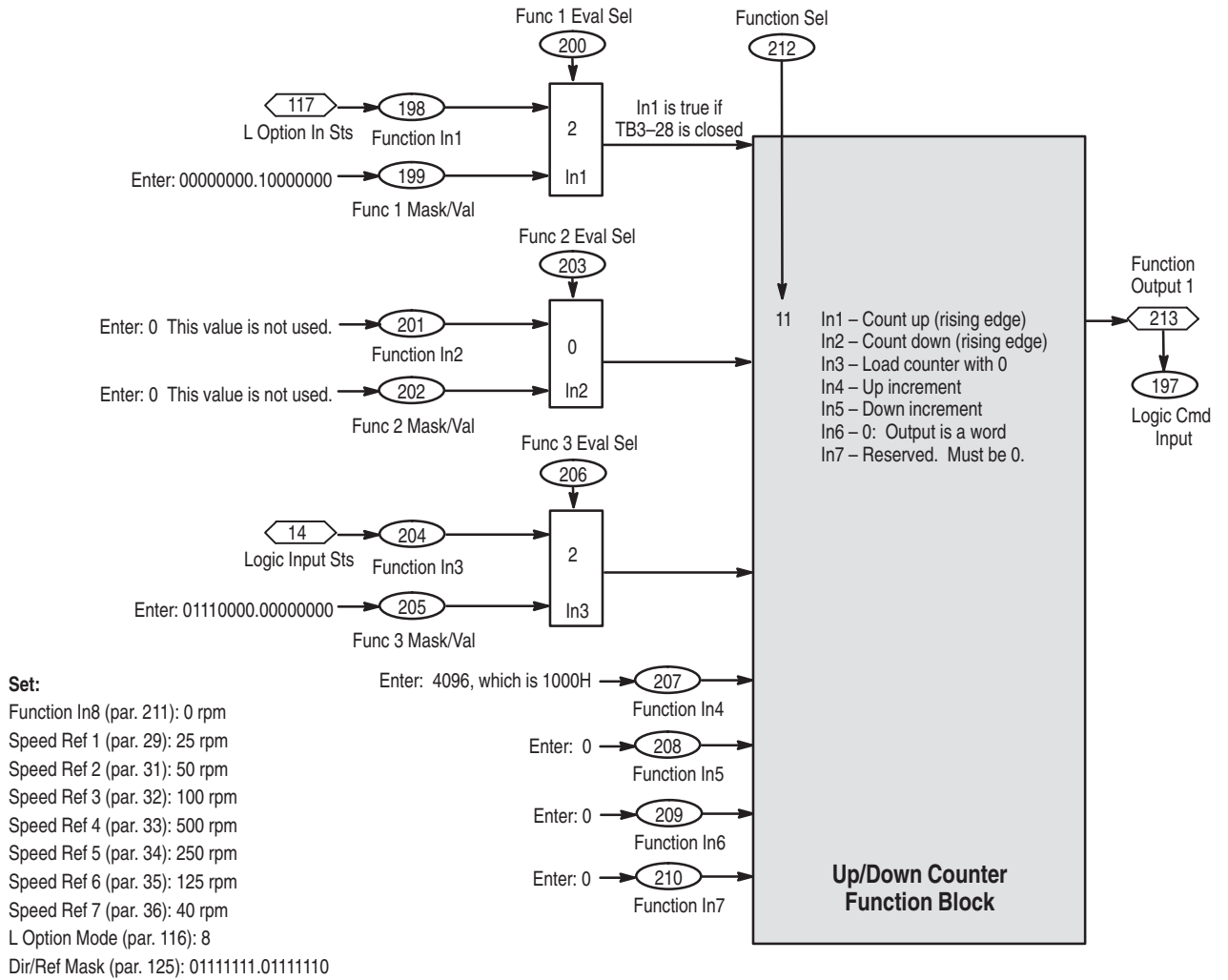
Figure 10.19 shows an example of a shuttle.

**Figure 10.19**  
**Example of a Simple Shuttle**



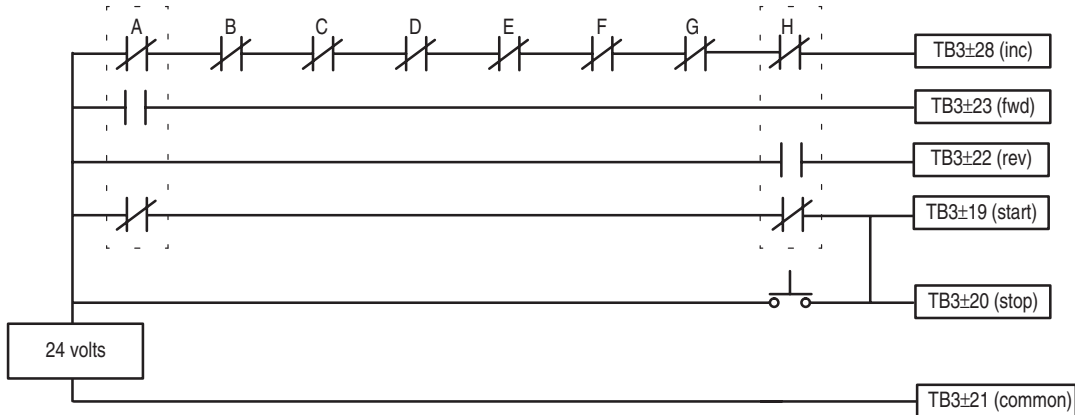
To set up the function block for this example, you would need to enter the values shown in Figure 10.20.

**Figure 10.20**  
**Up/Down Counter Function Block**



This works as shown in Figure 10.21.

**Figure 10.21**  
**Example of a Shuttle**



**Shuttle moves from A to H:**

Shuttle is closing switch A; forward direction and stop commanded  
 User presses and holds start button until switch A opens: increment (Speed Ref 1) and start commanded  
 Shuttle closes switch B; increment (Speed Ref 2) is commanded  
 Shuttle closes switch C; increment (Speed Ref 3) is commanded  
 Shuttle closes switch D; increment (Speed Ref 4) is commanded  
 Shuttle closes switch E; increment (Speed Ref 5) is commanded  
 Shuttle closes switch F; increment (Speed Ref 6) is commanded  
 Shuttle closes switch G; increment (Speed Ref 7) is commanded, counter set to zero (speed ref no change)  
 Shuttle closes switch H; reverse direction and stop commanded

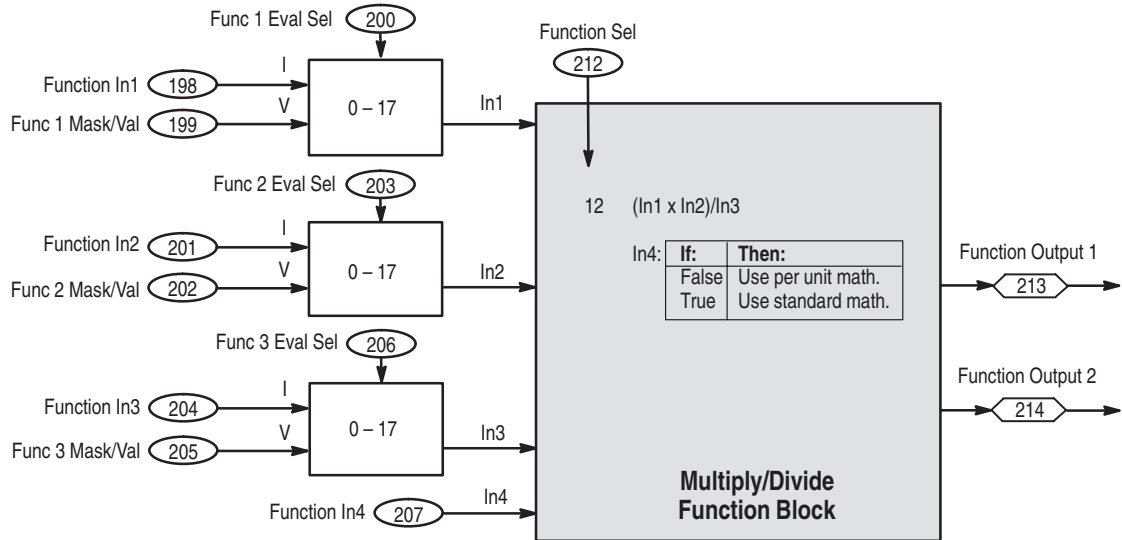
**Shuttle moves from H to A:**

Shuttle closes switch H; reverse direction and stop commanded  
 User presses and holds start button until switch H opens; increment (Speed Ref 1) and start commanded  
 Shuttle closes switch G; increment (Speed Ref 2) is commanded  
 Shuttle closes switch F; increment (Speed Ref 3) is commanded  
 Shuttle closes switch E; increment (Speed Ref 4) is commanded  
 Shuttle closes switch D; increment (Speed Ref 5) is commanded  
 Shuttle closes switch C; increment (Speed Ref 6) is commanded  
 Shuttle closes switch B; increment (Speed Ref 7) is commanded, counter set to zero (speed ref no change)  
 Shuttle closes switch A; forward direction and stop commanded

**Using the Multiply/Divide Function Block**

The multiply/divide function block multiplies the value of In1 with the value of In2 and then divides the result by the value of In3. The multiply/divide function block is shown in Figure 10.22.

**Figure 10.22**  
**Multiply/Divide Function Block**



The multiply/divide function can be performed as either standard math or per unit math. Per unit math lets you multiply/divide internal drive units on a per unit basis, where 4096 is equal to one unit. With per unit math,  $4096 \times 4096 = 4096$ , because you actually multiply 1 unit by 1 unit to get 1 unit. The equation used for per unit math is as follows:

$$\frac{\text{In1} \times \text{In2} \times 65536}{\text{IN3}} = 32 \text{ bit Out}$$

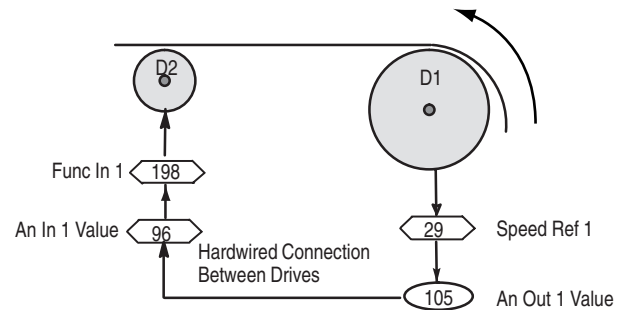
Example:  $\frac{(IN1) (IN2)}{100 (IN3)} = 1,068,373,115 \text{ (decimal)}$

Output:  $1,068,373,115 \text{ (dec)} = \begin{matrix} \text{3FAE} & \text{147B} \\ \text{MSW} & \text{LSW} \end{matrix} \text{ Hex}$

Output: 213		STD Math	PU Math
3FAE (hex) = 16,302 (dec)	P213	LSW = 0	Whl = 16302 dec
Output: 214			
147B (hex) = 5,243 (dec)	P214	MSW = 16302	Fract = 5243 dec

In this example, the drive controlling the smaller spindle follows the speed of the drive controlling the larger spindle. This example is shown in Figure 10.23.

**Figure 10.23**  
**Example of a Drive Ratio**



The smaller D2 will spin approximately 4.096 times faster than the D1 Drive. This Ratio is set by the IN2 and IN3 parameters.

$$\frac{\text{IN2}}{\text{IN3}} = \frac{16777}{4096} = \frac{4.096 \text{ PU D2}}{1 \text{ PU D1}}$$

If the current command speed of D1 Speed Ref P29 was 25% of its base speed, its value would be 1024.

$$.25 \times 4096 \text{ (1PU Base Speed)} = 1024$$

$$\text{IN1} = 1024$$

$$\text{IN2} = 16777$$

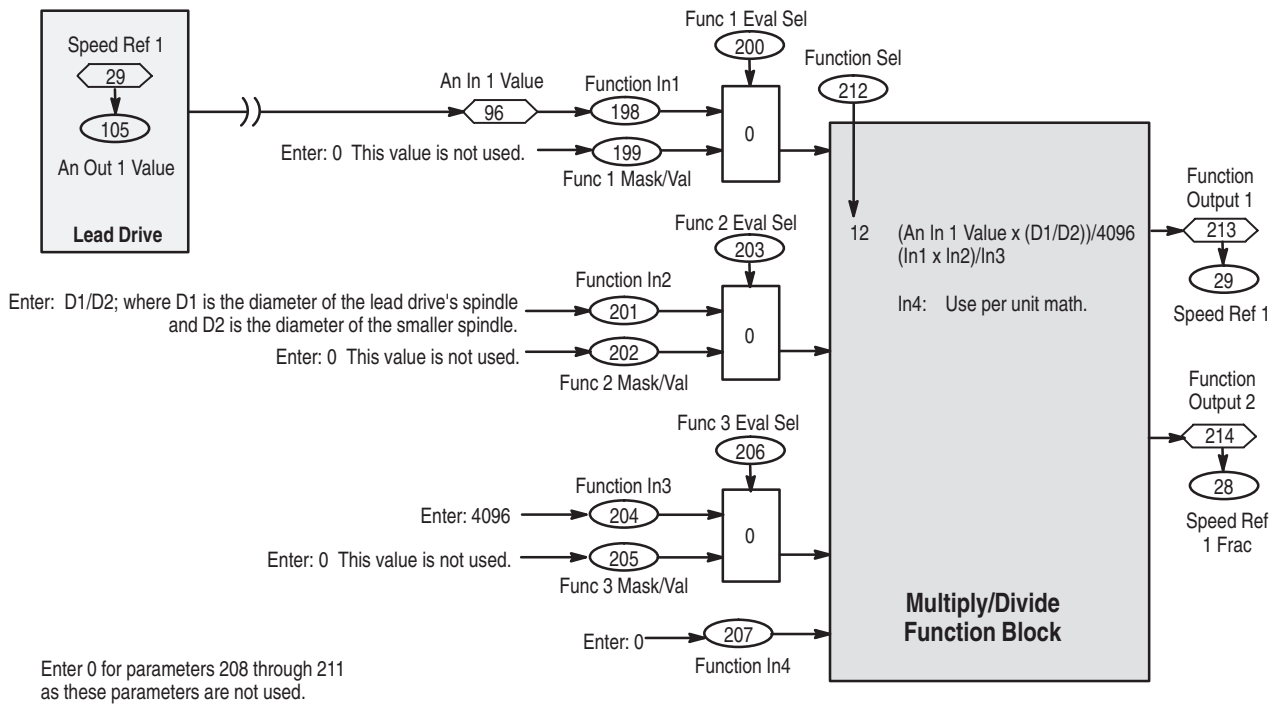
$$\text{IN3} = 4096$$

$$\begin{aligned}
 1024 \text{ (IN1)} \times 16777 \text{ (IN2)} \times 65536 &= \overset{(32 \text{ bit out})}{274,874,368 \text{ (dec)}} \\
 \underline{4096 \text{ (IN3)}} & \\
 &= \frac{1062}{4000} \text{ Hex} \\
 &\quad \text{WHL Fract} \\
 &\quad P213 P214
 \end{aligned}$$

The previous example assumes that both D1 & D2 have motor speeds of equal rating. Applications where motor speeds differ provide an even greater example of the flexibility of this function block.

To set up this application, you need to enter the values shown in Figure 10.24.

**Figure 10.24**  
**Multiply/Divide Function Block**

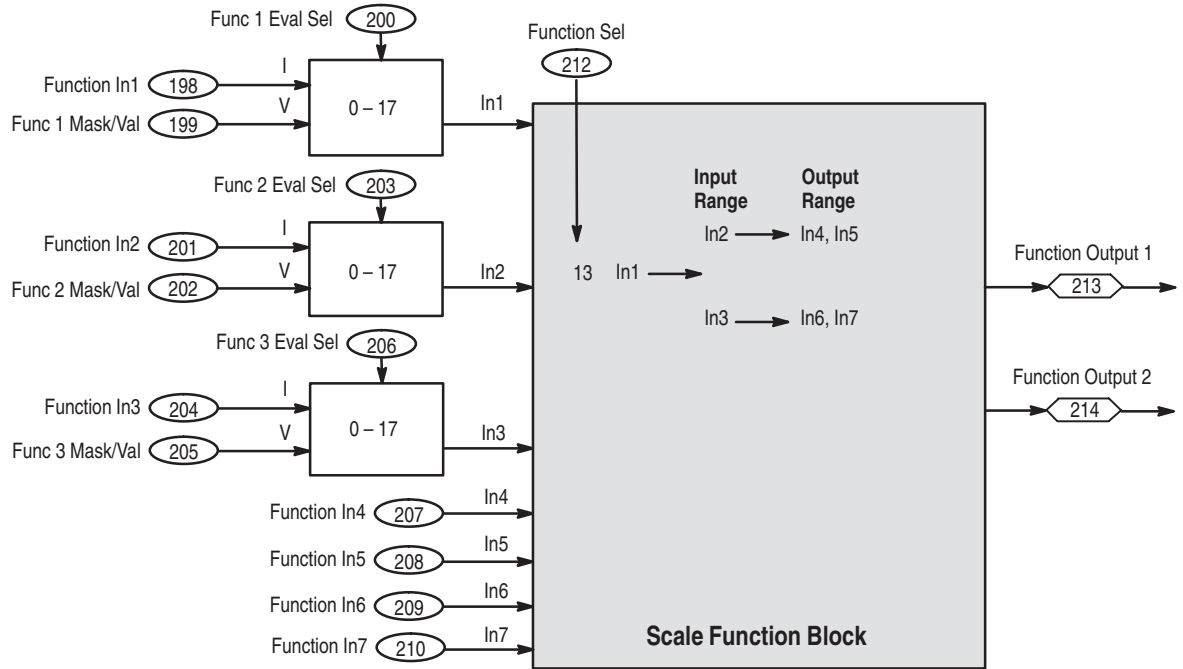


In this example, per unit math is used because the value coming in through *An In 1 Value* (parameter 96) is in internal units. The output value is also in internal units.

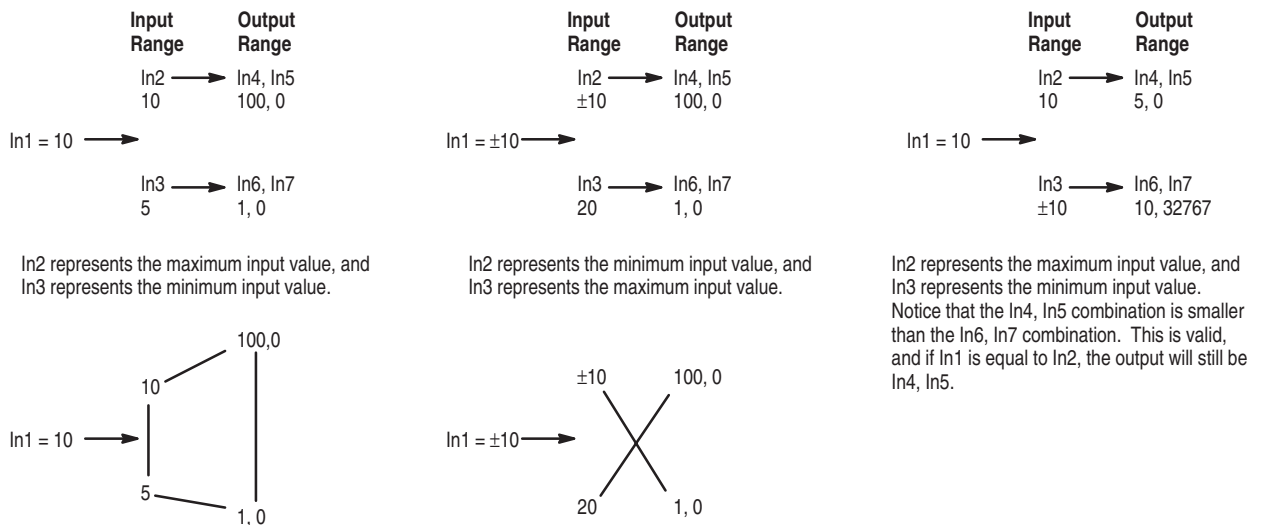
### Using the Scale Function

You can use the function block to set up a scale function. With this function block, you enter the input range and the output range, and the scale function block scales the input so that it stays within those ranges. The scale function block is shown in Figure 10.25.

**Figure 10.25**  
**Scale Function Block**



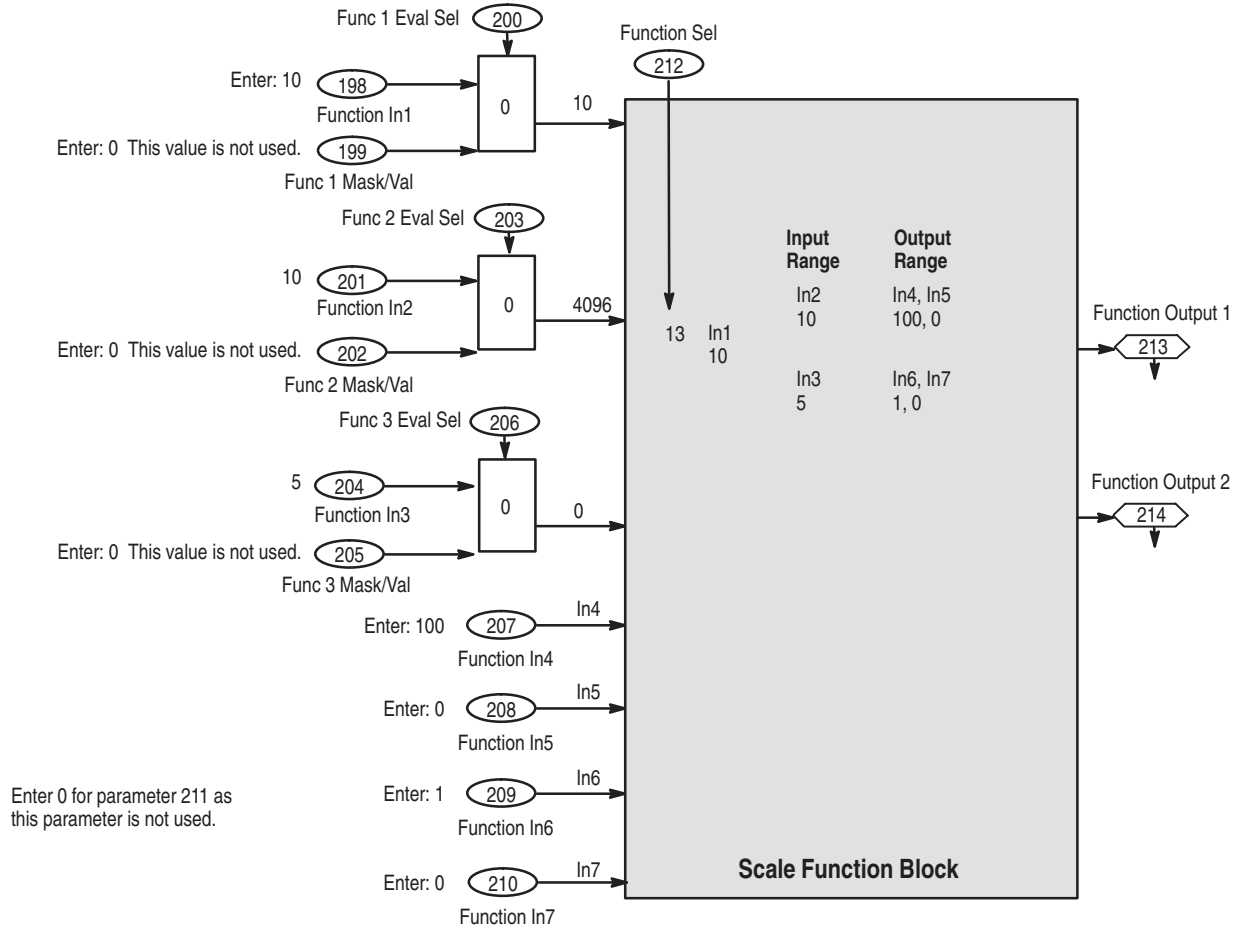
In1 is the input value. In2 and In3 specify the range that you want to use for the maximum and minimum values for In1. In4 and In5 represent a double word that corresponds to the output value that you want to use when In1 is equal to In2. In4 is the high word and In5 is the low word. Likewise, In6 and In7 represent a double word that corresponds to the output value that you want to use when In1 is equal to In3. Therefore, it does not matter which value, In2 or In3, you use for either the maximum or minimum. The following are some examples.



The output is also specified as a double word, with the high word in *Function Output 1* and the low word in *Function Output 2*.

As an example of the scale function block, you could ensure that the speed reference is kept to within a 10% range. To do this, you need to enter the values shown in Figure 10.26.

**Figure 10.26**  
**Example of the Scale Function Block**



**Converting Between Drive Units and RPM**

This section is provided to help you convert between drive units and rpm. The formula for the conversion is:

$$(Speed Ref 1 \times 65536 + Speed Ref 1 Frac) \times (Base motor speed / (4096 \times 65536)) = y \text{ rpm}$$



As an example the following table shows several drive unit values converted to rpm. A base speed of 1755 is used for this table.

Speed Reference		RPM
Whole	Fraction	
32767	65535	14039.99999346
4096	0	1755.00000000
1	0	0.42846680
0	65535	0.42846026
0	32767	0.21422686
0	1	0.00000654
-4	32711	-1.50000645
-4096	0	-1755.00000000

The formula for converting from rpm to internal units is as follows:

$$\left[ \frac{y \text{ rpm}}{(\text{base motor speed}/(4096 \times 65536))} \right] \div 65536 = \text{Whole, Fractional (remainder)}$$

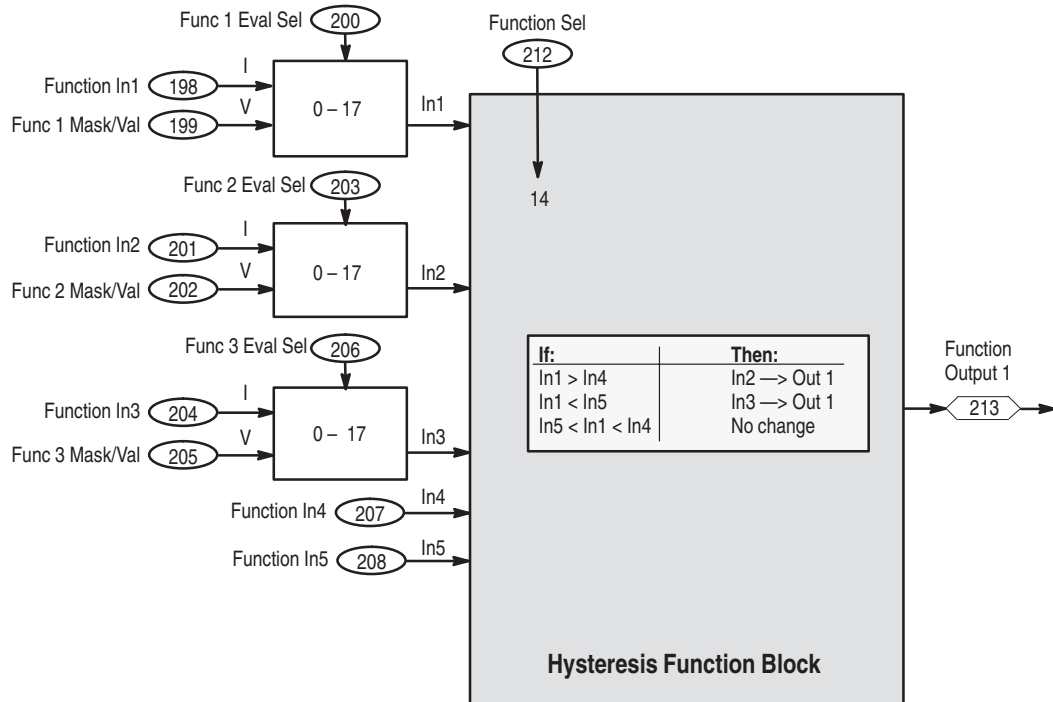
The following table shows several values in rpm converted to drive units. Again, a base speed of 1755 is used.

RPM	Speed Reference	
	Whole	Fraction
1755	4096	0
0.4284668	1	0
0.42846026	0	65535
0.9	2	6587
-1755	-4096	0
-1.5	-4	32711
2000	4667	52839
0.5	1	10941

## Using the Hysteresis Function

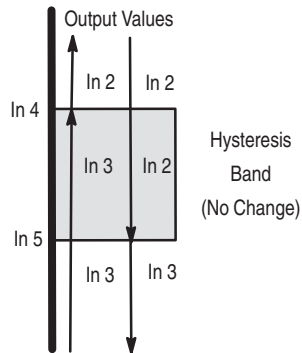
The hysteresis function lets you select a value based on whether Input 1 is greater than Input 4 or less than Input 5. If Input 1 is between Input 4 and Input 5, then the value does not change. Figure 10.27 shows the parameters that are used for the hysteresis function and how these parameters are evaluated.

**Figure 10.27**  
**Hysteresis Function Block**



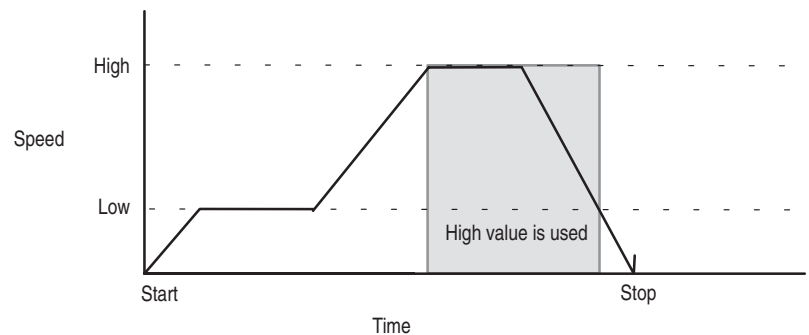
The hysteresis function provides a band in which the output value does not change. For example, if an input value is greater than Input 4, the output value is Input 2. As the input value decrease, the output value remains Input 2 until the input value is less than Input 5. Refer to Figure 10.28.

**Figure 10.28**  
**Hysteresis**



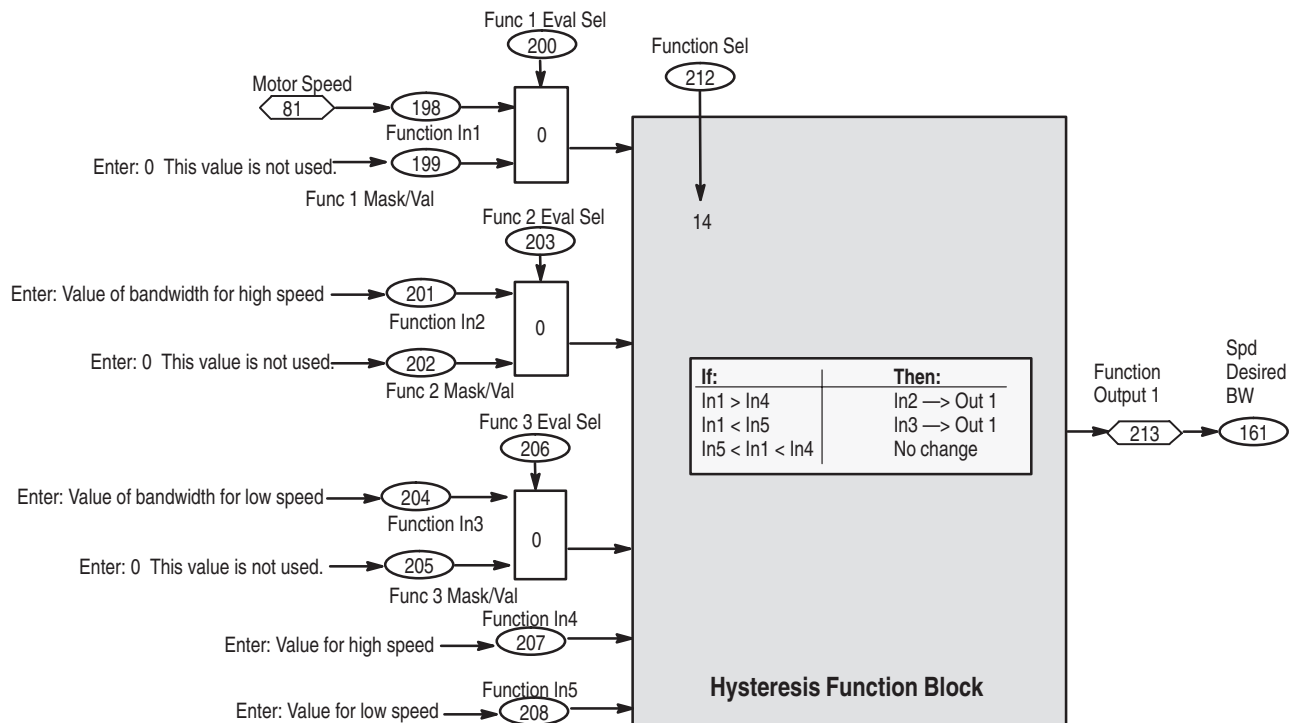
As an example, you could use the hysteresis function to fine tune the speed regulator across a broad speed range and ensure that the drive does not oscillate between the two configurations at any particular speed. To ensure that the speed regulator is finely tuned at both the low and the high speed in the range, the drive is tuned for each speed, and the two values of *Spd Desired BW* (parameter 161) are noted. The drive uses the low value when it is at low speed. It uses the high value when it is at high speed. When it is between the high speed and low speed, it uses the last specified value. This example is shown in Figure 10.29.

**Figure 10.29**  
**Example of Hysteresis**



To set up the function block for this application, you would need to enter the values shown in Figure 10.30.

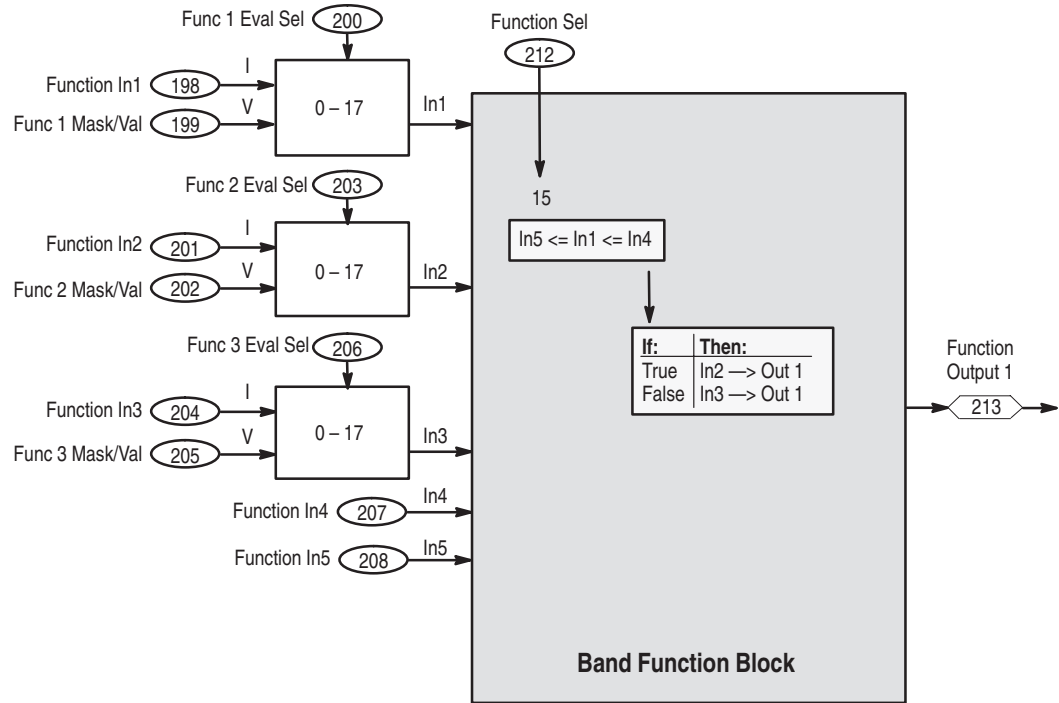
**Figure 10.30**  
**Hysteresis Function Block**



### Using the Band Function

The band function lets you select a value based on whether Input 1 is within a range or outside of a range. Figure 10.31 shows the parameters that are used for the band function and how these parameters are evaluated.

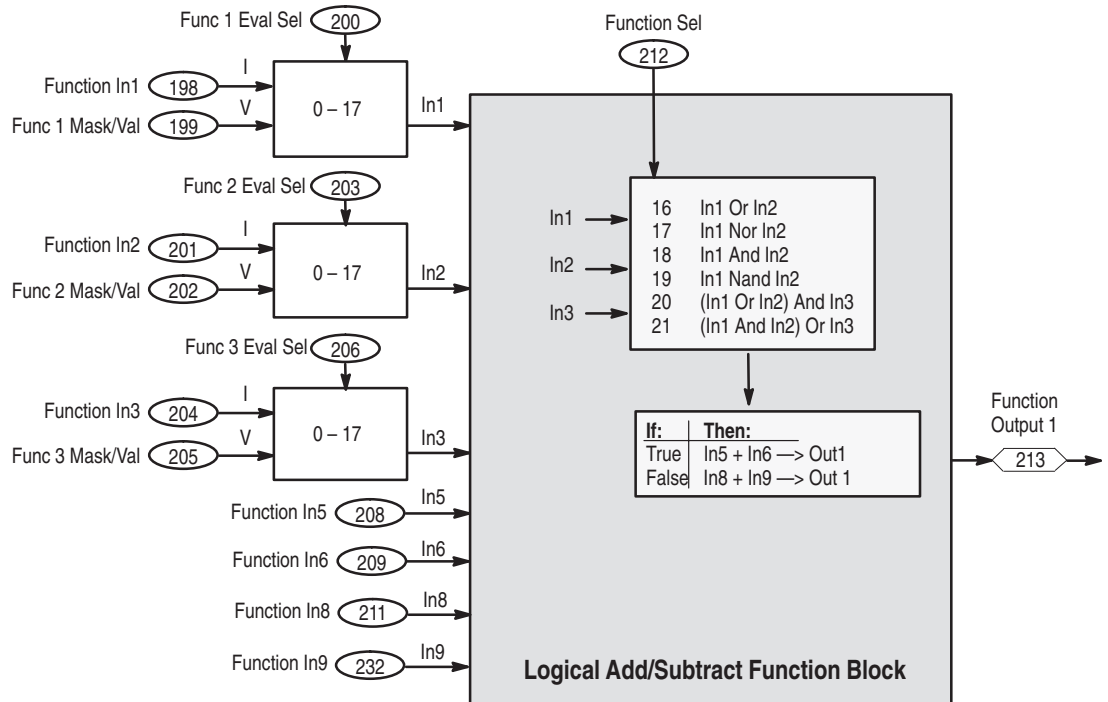
**Figure 10.31**  
**Band Function Block**



### Using the Logical Add/Subtract Function

The logical add/subtract function lets you use a logical operator to determine whether to add Input 5 and Input 6 or Input 8 and Input 9. Figure 10.32 shows the parameters that are used for the logical add/subtract function and how these parameters are evaluated.

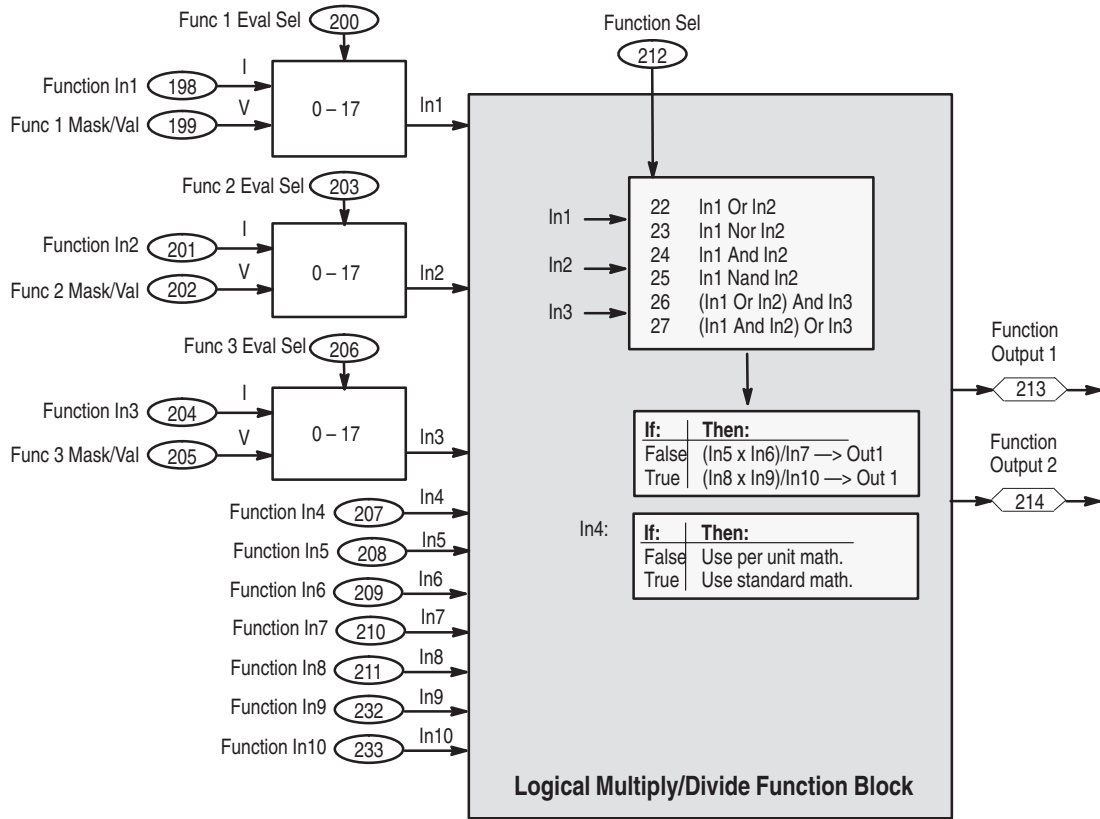
**Figure 10.32**  
**Logical Add/Subtract Function Block**



### Using the Logical Multiply/Divide Function

The logical multiply/divide function lets you use a logical operator to determine whether to multiply the value of Input 5 with the value of Input 6 and then divide the result by the value of Input 7 or multiply the value of Input 8 with the value of Input 9 and then divide the result by the value of Input 10. Figure 10.33 shows the parameters that are used for the logical multiply/divide function and how these parameters are evaluated.

**Figure 10.33**  
**Logical Multiply/Divide Function Block**



The logical multiply/divide function can be performed as either standard math or per unit math. Per unit math lets you multiply/divide internal drive units on a per unit basis, where 4096 is equal to one unit. With per unit math,  $4096 \times 4096 = 4096$ , because you actually multiply 1 unit by 1 unit to get 1 unit. The equation used for per unit math is as follows:

$$\frac{\left(\frac{In1}{4096}\right) \times \left(\frac{In2}{4096}\right) \times 65536}{\left(\frac{In3}{4096}\right)} = \left(\frac{Out1, 2}{4096}\right)$$

Out1 = Whole Value  
Out2 = Fractional Value

## Parameters

### Chapter Objectives

Chapter 11 provides the information about the parameters that you can use to program the 1336 IMPACT drive.

This topic:	Starts on page:
The parameter files and groups	11-1
A numerical listing of the parameters	11-5
An alphabetical listing of the parameters	11-7
The conventions used to describe the parameters	11-9
Descriptions of the parameters	11-9

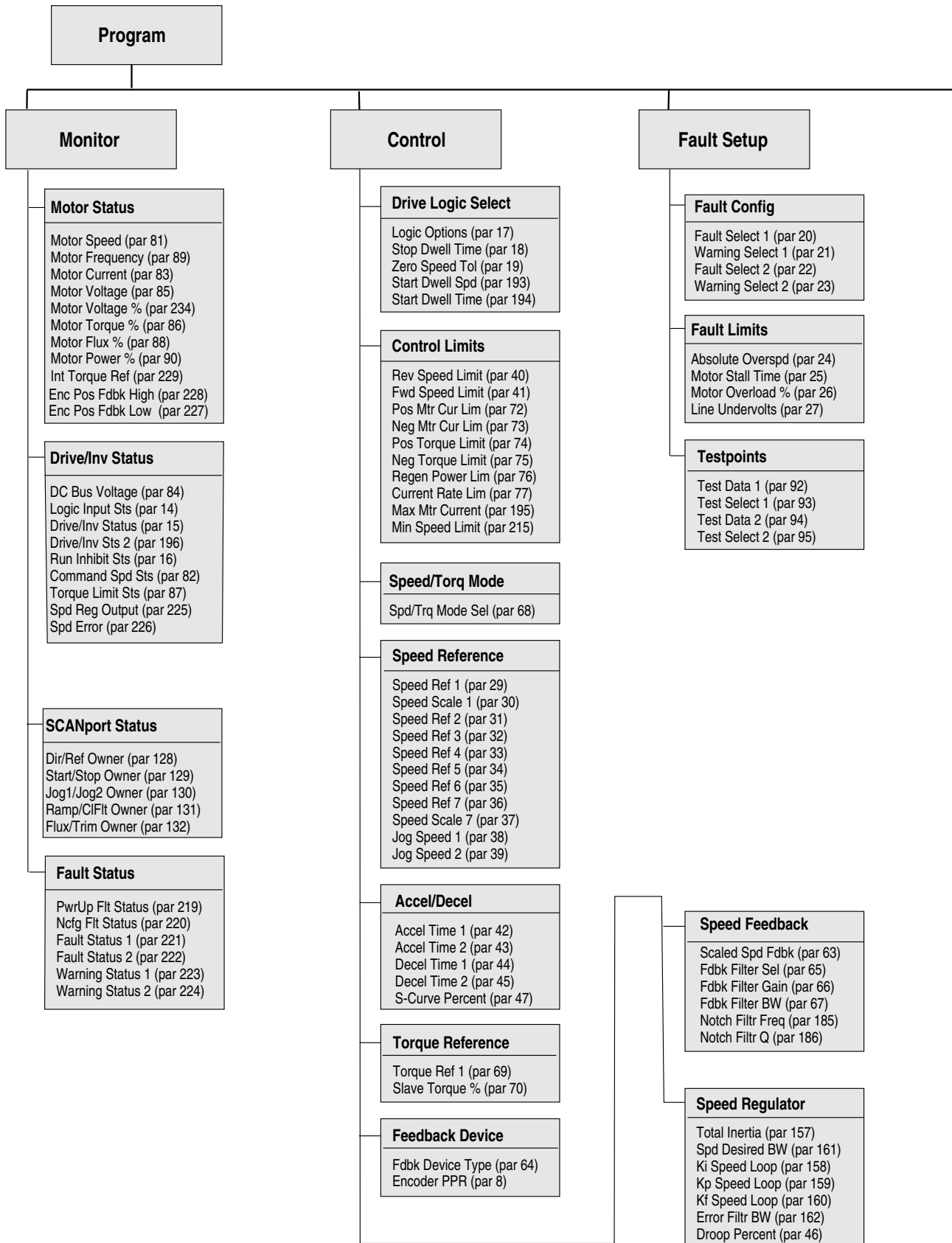
**Important:** When you change the value of a parameter, the value is automatically stored.

### Understanding the Parameter Files and Groups

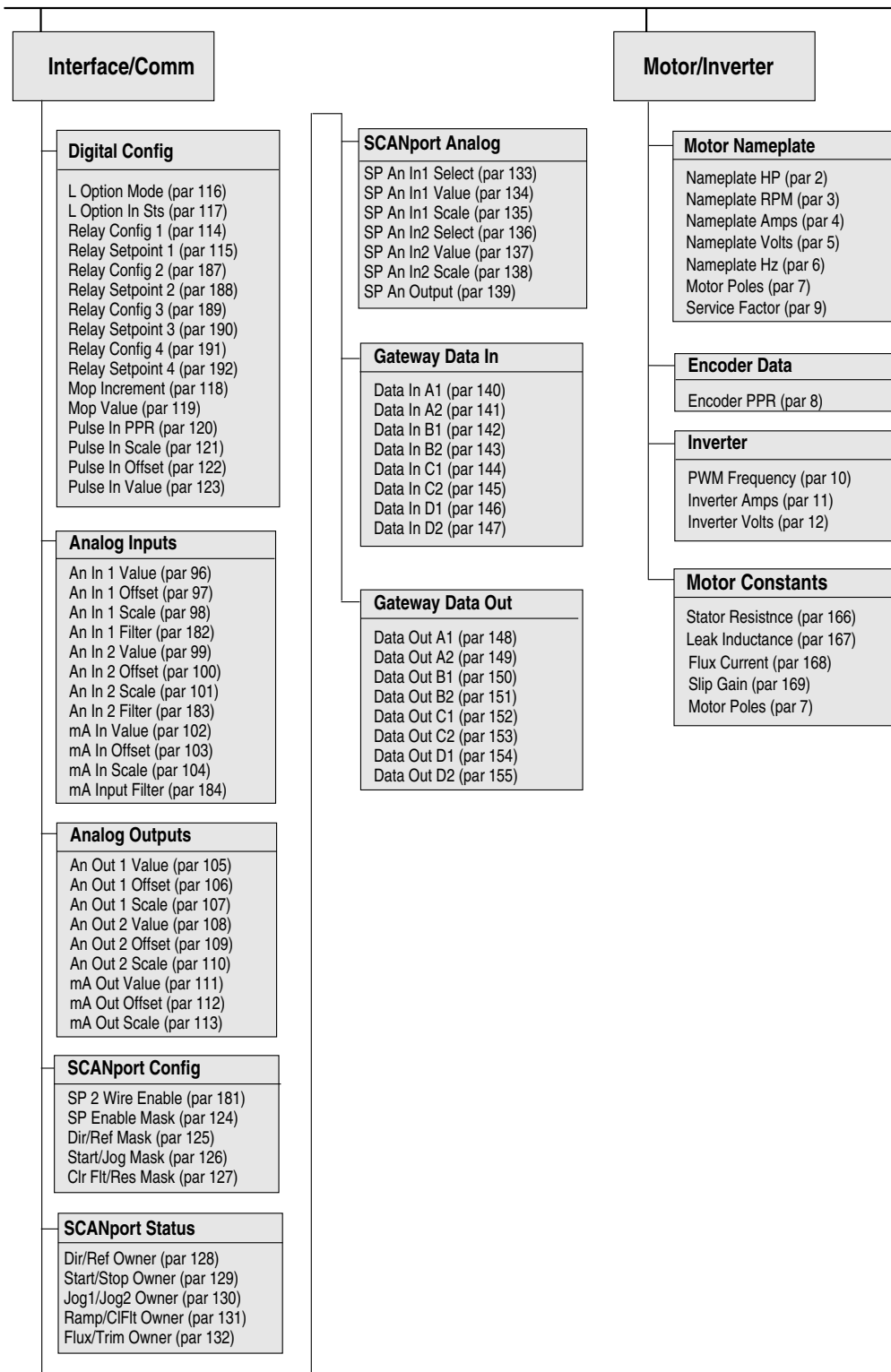
Parameters are divided into seven files to help ease programming and operator access. These files are divided into groups, and each parameter is an element in a specific group. Parameters may be used as elements in more than one group.

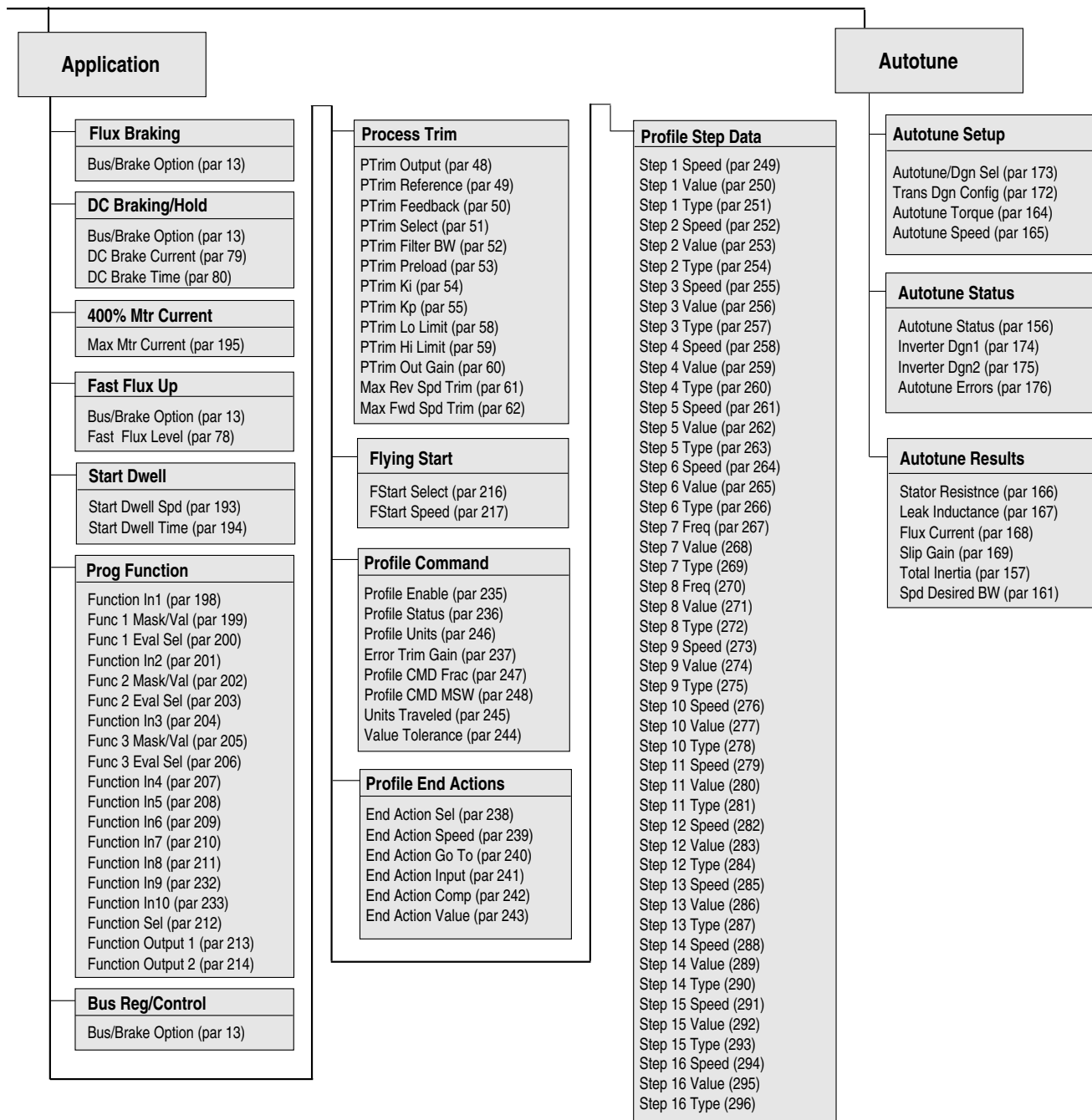
You can also view the parameters in a linear mode. This lets you view the entire parameter table in numerical order. You can access the linear mode from the bottom of any group.

The following tables list the parameters that are available in each file and group.









**Numerical Parameter Listing**

The following table lists the parameters in numerical order

No.	Name	Page
1	Language Select	11-10
2	Nameplate HP	11-10
3	Nameplate RPM	11-10
4	Nameplate Amps	11-10
5	Nameplate Volts	11-10
6	Nameplate Hz	11-10
7	Motor Poles	11-11
8	Encoder PPR	11-11
9	Service Factor	11-11
10	PWM Frequency	11-11
11	Inverter Amps	11-11
12	Inverter Volts	11-11
13	Bus/Brake Opts	11-12
14	Logic Input Sts	11-13
15	Drive/Inv Status	11-13
16	Run Inhibit Sts	11-14
17	Logic Options	11-14
18	Stop Dwell Time	11-14
19	Zero Speed Tol	11-15
20	Fault Select 1	11-15
21	Warning Select 1	11-16
22	Fault Select 2	11-16
23	Warning Select 2	11-17
24	Absolute Overspd	11-17
25	Motor Stall Time	11-17
26	Motor Overload %	11-17
27	Line Undervolts	11-17
28	Speed Ref 1 Frac	11-18
29	Speed Ref 1	11-18
30	Speed Scale 1	11-18
31	Speed Ref 2	11-18
32	Speed Ref 3	11-18
33	Speed Ref 4	11-18
34	Speed Ref 5	11-19
35	Speed Ref 6	11-19
36	Speed Ref 7	11-19
37	Speed Scale 7	11-19
38	Jog Speed 1	11-19
39	Jog Speed 2	11-19
40	Rev Speed Limit	11-20
41	Fwd Speed Limit	11-20
42	Accel Time 1	11-20
43	Accel Time 2	11-20
44	Decel Time 1	11-20
45	Decel Time 2	11-20
46	Droop Percent	11-21
47	S-Curve Percent	11-21

No.	Name	Page
48	PTrim Output	11-21
49	PTrim Reference	11-21
50	PTrim Feedback	11-21
51	PTrim Select	11-22
52	PTrim Filter BW	11-22
53	PTrim Preload	11-22
54	PTrim Ki	11-23
55	PTrim Kp	11-22
56	Reserved	11-22
57	Reserved	11-23
58	PTrim Lo Limit	11-23
59	PTrim Hi Limit	11-23
60	PTrim Out Gain	11-24
61	Max Rev Spd Trim	11-24
62	Max Fwd Spd Trim	11-24
63	Scaled Spd Fdbk	11-24
64	Fdbk Device Type	11-24
65	Fdbk Filter Sel	11-25
66	Fdbk Filter Gain	11-25
67	Fdbk Filter BW	11-25
68	Spd/Trq Mode Sel	11-26
69	Torque Ref 1	11-26
70	Slave Torque %	11-26
71	Min Flux Level	11-26
72	Pos Mtr Cur Lim	11-27
73	Neg Mtr Cur Lim	11-27
74	Pos Torque Lim	11-27
75	Neg Torque Lim	11-27
76	Regen Power Lim	11-27
77	Current Rate Lim	11-28
78	Fast Flux Level	11-28
79	DC Brake Current	11-28
80	DC Brake Time	11-28
81	Motor Speed	11-28
82	Command Spd Sts	11-28
83	Motor Current	11-29
84	DC Bus Voltage	11-29
85	Motor Voltage	11-29
86	Motor Torque %	11-29
87	Torque Limit Sts	11-30
88	Motor Flux %	11-30
89	Motor Frequency	11-30
90	Motor Power %	11-30
91	Iq%	11-31
92	Test Data 1	11-31
93	Test Select 1	11-31
94	Test Data 2	11-31

No.	Name	Page
95	Test Select 2	11-32
96	An In 1 Value	11-33
97	An In 1 Offset	11-33
98	An In 1 Scale	11-33
99	An In 2 Value	11-33
100	An In 2 Offset	11-34
101	An In 2 Scale	11-34
102	mA Input Value	11-34
103	mA Input Offset	11-34
104	mA Input Scale	11-34
105	An Out 1 Value	11-34
106	An Out 1 Offset	11-35
107	An Out 1 Scale	11-35
108	An Out 2 Value	11-35
109	An Out 2 Offset	11-35
110	An Out 2 Scale	11-35
111	mA Out Value	11-35
112	mA Out Offset	11-36
113	mA Out Scale	11-36
114	Relay Config 1	11-36
115	Relay Setpoint 1	11-37
116	L Option Mode	11-37
117	L Option In Sts	11-38
118	Mop Increment	11-38
119	Mop Value	11-38
120	Pulse In PPR	11-38
121	Pulse In Scale	11-38
122	Pulse In Offset	11-39
123	Pulse In Value	11-39
124	SP Enable Mask	11-39
125	Dir/Ref Mask	11-40
126	Start/Jog Mask	11-40
127	Clr Flt/Res Mask	11-41
128	Dir/Ref Owner	11-41
129	Start/Stop Owner	11-42
130	Jog1/Jog2 Owner	11-42
131	Ramp/CIFlt Owner	11-43
132	Flux/Trim Owner	11-43
133	SP An In1 Select	11-44
134	SP An In1 Value	11-44
135	SP An In1 Scale	11-44
136	SP An In2 Select	11-44
137	SP An In2 Value	11-44
138	SP An In2 Scale	11-45
139	SP An Output	11-45
140	Data In A1	11-45
141	Data In A2	11-45

No.	Name	Page	No.	Name	Page	No.	Name	Page
142	Data In B1	11-45	194	Start Dwell Time	11-59	246	Units Traveled	11-76
143	Data In B2	11-45	195	Max Mtr Current	11-59	247	Profile CMD Frac	11-76
144	Data In C1	11-46	196	Drive/Inv Sts 2	11-60	248	Profile CMD	11-76
145	Data In C2	11-46	197	Logic Cmd Input	11-60	249	Step 1 Speed	11-76
146	Data In D1	11-46	198	Function In1	11-61	250	Step 1 Value	11-76
147	Data In D2	11-46	199	Func 1 Mask/Val	11-61	251	Step 1 Type	11-76
148	Data Out A1	11-46	200	Func 1 Eval Sel	11-62	252	Step 2 Speed	11-77
149	Data Out A2	11-46	201	Function In2	11-62	253	Step 2 Value	11-77
150	Data Out B1	11-47	202	Func 2 Mask/Val	11-63	254	Step 2 Type	11-77
151	Data Out B2	11-47	203	Func 2 Eval Sel	2-63	255	Step 3 Speed	11-77
152	Data Out C1	11-47	204	Function In3	2-64	256	Step 3 Value	11-77
153	Data Out C2	11-47	205	Func 3 Mask/Val	2-64	257	Step 3 Type	11-77
154	Data Out D1	11-47	206	Func 3 Eval Sel	2-65	258	Step 4 Speed	11-78
155	Data Out D2	11-47	207	Function In4	2-65	259	Step 4 Value	11-78
156	Autotune Status	11-48	208	Function In5	2-66	260	Step 4 Type	11-78
157	Total Inertia	11-48	209	Function In6	2-66	261	Step 5 Speed	11-78
158	Ki Speed Loop	11-48	210	Function In7	2-66	262	Step 5 Value	11-78
159	Kp Speed Loop	11-48	211	Function In8	2-67	263	Step 5 Type	11-78
160	Kf Speed Loop	11-49	212	Function Sel	2-68	264	Step 6 Speed	11-79
161	Spd Desired BW	11-49	213	Function Output1	2-69	265	Step 6 Value	11-79
162	Error Filtr BW	11-49	214	Function Output2	2-69	266	Step 6 Type	11-79
163	Reserved	11-49	215	Min Speed Limit	2-69	267	Step 7 Speed	11-79
164	Autotune Torque	11-49	216	FStart Select	11-69	268	Step 7 Value	11-79
165	Autotune Speed	11-50	217	FStart Speed	11-70	269	Step 7 Type	11-79
166	Stator Resistnce	11-50	218	Reserved	11-70	270	Step 8 Speed	11-80
167	Leak Inductance	11-50	219	PwrUp Flt Status	11-70	271	Step 8 Value	11-80
168	Flux Current	11-50	220	Ncfg Flt Status	11-70	272	Step 8 Type	11-80
169	Slip Gain	11-50	221	Fault Status 1	11-71	273	Step 9 Speed	11-80
170	Vd Max	11-51	222	Fault Status 2	11-71	274	Step 9 Type	11-80
171	Vq Max	11-51	223	Warning Status 1	11-71	275	Step 9 Value	11-80
172	Trans Dgn Config	11-51	224	Warning Status 2	11-72	276	Step 10 Speed	11-81
173	Autotune/Dgn Sel	11-51	225	Spd Reg Output	11-72	277	Step 10 Type	11-81
174	Inverter Dgn1	11-52	226	Spd Error	11-72	278	Step 10 Value	11-81
175	Inverter Dgn2	11-52	227	Enc Pos Fdbk Low	11-72	279	Step 11 Speed	11-81
176	Autotune Errors	11-53	228	Enc Pos fdbk Hi	11-72	280	Step 11 Type	11-81
177	Ki Freq Reg	11-53	229	Int Torque Ref	11-73	281	Step 11 Value	11-81
178	Kp Freq Reg	11-53	230	Iq Offset	11-73	282	Step 12 Speed	11-82
179	Kf Freq Reg	11-53	231	Id Offset	11-73	283	Step 12 Value	11-82
180	Freq Track Filtr	11-54	232	Function In9	11-73	284	Step 12 Type	11-82
181	SP 2 Wire Enable	11-54	233	Function In10	11-73	285	Step 13 Speed	11-82
182	An In1 Filter BW	11-54	234	Motor Voltage %	11-73	286	Step 13 Value	11-82
183	An In2 Filter BW	11-54	235	Profile Enable	11-74	287	Step 13 Type	11-82
184	mA In Filter BW	11-54	236	Profile Status	11-74	288	Step 14 Speed	11-83
185	Notch Filtr Freq	11-55	237	Error Trim Gain	11-74	289	Step 14 Value	11-83
186	Notch Filtr Q	11-55	238	End Action Sel	11-74	290	Step 14 Type	11-83
187	Relay Config 2	11-56	239	End Action Speed	11-74	291	Step 15 Speed	11-83
188	Relay Setpoint 2	11-56	240	End Action Go To	11-75	292	Step 15 Value	11-83
189	Relay Config 3	11-57	241	End Action Input	11-75	293	Step 15 Type	11-83
190	Relay Setpoint 3	11-57	242	End Action Comp	11-75	294	Step 16 Speed	11-84
191	Relay Config 4	11-58	243	End Action Val	11-75	295	Step 16 Value	11-84
192	Relay Setpoint 4	11-58	244	Value Tolerance	11-75	296	Step 16 Type	11-84
193	Start Dwell Spd	11-59	245	Counts per unit	11-75			

**Alphabetical Parameter Listing**

The following is an alphabetical listing of the parameters.

Name	No.	Page
Absolute Overspd	24	11-10
Accel Time 1	42	11-20
Accel Time 2	43	11-20
An In 1 Offset	97	11-33
An In 1 Scale	98	11-33
An In 1 Value	96	11-33
An In 2 Offset	100	11-34
An In 2 Scale	101	11-34
An In 2 Value	99	11-33
An In1 Filter BW	182	11-54
An In2 Filter BW	183	11-54
An Out 1 Offset	106	11-35
An Out 1 Scale	107	11-35
An Out 1 Value	105	11-34
An Out 2 Offset	109	11-35
An Out 2 Scale	110	11-35
An Out 2 Value	108	11-35
Autotune Errors	176	11-53
Autotune Speed	165	11-50
Autotune Status	156	11-48
Autotune Torque	164	11-49
Autotune/Dgn Sel	173	11-51
Bus/Brake Opts	13	11-12
Clr Flt/Res Mask	127	11-41
Command Spd Sts	82	11-28
Counts Per Unit	245	11-75
Current Rate Lim	77	11-28
Data In A1	140	11-45
Data In A2	141	11-45
Data In B1	142	11-45
Data In B2	143	11-45
Data In C1	144	11-46
Data In C2	145	11-46
Data In D1	146	11-46
Data In D2	147	11-46
Data Out A1	148	11-46
Data Out A2	149	11-46
Data Out B1	150	11-47
Data Out B2	151	11-47
Data Out C1	152	11-47
Data Out C2	153	11-47
Data Out D1	154	11-47
Data Out D2	155	11-47
DC Brake Current	79	11-28
DC Brake Time	80	11-28
DC Bus Voltage	84	11-29
Decel Time 1	44	11-20
Decel Time 2	45	11-20
Dir/Ref Mask	125	11-40
Dir/Ref Owner	128	11-41

Name	No.	Page
Drive/Inv Status	15	11-13
Drive/Inv Sts 2	196	11-60
Droop Percent	46	11-21
Enc Pos fdbk Hi	228	11-72
Enc Pos Fdbk Low	227	11-72
Encoder PPR	8	11-11
End Action Sel	238	11-74
End Action Speed	239	11-74
End Action Go To	240	11-74
End Action Input	241	11-75
End Action Comp	242	11-75
End Action Value	243	11-75
Error Filtr BW	162	11-49
Error Trim Gain	237	11-74
Fast Flux Level	78	11-28
Fault Select 1	20	11-15
Fault Select 2	22	11-16
Fault Status 1	221	11-71
Fault Status 2	222	11-71
Fdbk Device Type	64	11-24
Fdbk Filter BW	67	11-25
Fdbk Filter Gain	66	11-25
Fdbk Filter Sel	65	11-25
Flux Current	168	11-50
Flux/Trim Owner	132	11-43
Freq Track Filtr	180	11-54
FStart Select	216	11-69
FStart Speed	217	11-70
Func 1 Eval Sel	200	11-62
Func 1 Mask/Val	199	11-61
Func 2 Eval Sel	203	11-63
Func 2 Mask/Val	202	11-63
Func 3 Eval Sel	206	11-65
Func 3 Mask/Val	205	11-64
Function In1	198	11-61
Function In10	233	11-73
Function In2	201	11-62
Function In3	204	11-64
Function In4	207	11-65
Function In5	208	11-66
Function In6	209	11-66
Function In7	210	11-67
Function In8	211	11-67
Function In9	232	11-73
Function Output1	213	11-69
Function Output2	214	11-69
Function Sel	212	11-68
Fwd Speed Limit	41	11-20
Id Offset	231	11-73
Int Torque Ref	229	11-73

Name	No.	Page
Inverter Amps	11	11-11
Inverter Dgn1	174	11-52
Inverter Dgn2	175	11-52
Inverter Volts	12	11-11
Iq Offset	230	11-73
Iq%	91	11-31
Jog Speed 1	38	11-19
Jog Speed 2	39	11-19
Jog1/Jog2 Owner	130	11-42
Kf Freq Reg	179	11-53
Kf Speed Loop	160	11-49
Ki Freq Reg	177	11-53
Ki Speed Loop	158	11-48
Kp Freq Reg	178	11-53
Kp Speed Loop	159	11-48
L Option In Sts	117	11-38
L Option Mode	116	11-37
Language Select	1	11-10
Leak Inductance	167	11-50
Line Undervolts	27	11-17
Logic Cmd Input	197	11-60
Logic Input Sts	14	11-13
Logic Options	17	11-14
mA In Filter BW	184	11-54
mA Input Offset	103	11-34
mA Input Scale	104	11-34
mA Input Value	102	11-34
mA Out Offset	112	11-36
mA Out Scale	113	11-36
mA Out Value	111	11-35
Max Fwd Spd Trim	62	11-24
Max Mtr Current	195	11-59
Max Rev Spd Trim	61	11-24
Min Flux Level	71	11-26
Min Speed Limit	215	11-69
Mop Increment	118	11-38
Mop Value	119	11-38
Motor Current	83	11-29
Motor Flux %	88	11-30
Motor Frequency	89	11-30
Motor Overload %	26	11-17
Motor Poles	7	11-11
Motor Power %	90	11-30
Motor Speed	81	11-28
Motor Stall Time	25	11-17
Motor Torque %	86	11-29
Motor Voltage	85	11-29
Motor Voltage %	234	11-73
Nameplate Amps	4	11-10
Nameplate HP	2	11-10

Name	No.	Page	Name	No.	Page	Name	No.	Page
Nameplate Hz	6	11-10	Slave Torque %	70	11-26	Step 7 Speed	267	11-79
Nameplate RPM	3	11-10	Slip Gain	169	11-50	Step 7 Value	268	11-79
Nameplate Volts	5	11-10	SP 2 Wire Enable	181	11-26	Step 7 Type	269	11-80
Ncfg Flt Status	220	11-70	SP An In1 Scale	135	11-50	Step 8 Speed	270	11-80
Neg Mtr Cur Lim	73	11-27	SP An In1 Select	133	11-54	Step 8 Value	271	11-80
Neg Torque Lim	75	11-27	SP An In1 Value	134	11-44	Step 8 Type	272	11-80
Notch Filtr Freq	185	11-55	SP An In2 Scale	138	11-44	Step 9 Speed	273	11-80
Notch Filtr Q	186	11-55	SP An In2 Select	136	11-44	Step 9 Value	274	11-80
Pos Mtr Cur Lim	72	11-27	SP An In2 Value	137	11-45	Step 9 Type	275	11-80
Pos Torque Lim	74	11-27	SP An Output	139	11-44	Step 10 Speed	276	11-81
Profile Enable	235	2-72	SP Enable Mask	124	11-44	Step 10 Value	277	11-81
Profile Status	236	2-72	Spd Desired BW	161	11-45	Step 10 Type	278	11-81
PTrim Feedback	50	11-21	Spd Error	226	11-39	Step 11 Speed	279	11-81
PTrim Filter BW	52	11-22	Spd Reg Output	225	11-49	Step 11 Value	280	11-81
PTrim Hi Limit	59	11-23	Spd/Trq Mode Sel	68	11-72	Step 11 Type	281	11-81
PTrim Ki	54	11-22	Speed Ref 1	29	11-72	Step 12 Speed	282	11-82
PTrim Kp	55	11-23	Speed Ref 1 Frac	28	11-26	Step 12 Value	283	11-82
PTrim Lo Limit	58	11-23	Speed Ref 2	31	11-18	Step 12 Type	284	11-82
PTrim Out Gain	60	11-24	Speed Ref 3	32	11-18	Step 13 Speed	285	11-82
PTrim Output	48	11-21	Speed Ref 4	33	11-18	Step 13 Value	286	11-82
PTrim Preload	53	11-22	Speed Ref 5	34	11-18	Step 13 Type	287	11-82
PTrim Reference	49	11-21	Speed Ref 6	35	11-18	Step 14 Speed	288	11-83
PTrim Select	51	11-22	Speed Ref 7	36	11-19	Step 14 Value	289	11-83
Pulse In Offset	122	11-39	Speed Scale 1	30	11-19	Step 14 Type	290	11-83
Pulse In PPR	120	11-38	Speed Scale 7	37	11-19	Step 15 Speed	291	11-83
Pulse In Scale	121	11-38	Start Dwell Spd	193	11-18	Step 15 Value	292	11-83
Pulse In Value	123	11-39	Start Dwell Time	194	11-19	Step 15 Type	293	11-83
PWM Frequency	10	11-11	Start/Jog Mask	126	11-59	Step 16 Speed	294	11-84
PwrUp Flt Status	219	11-70	Start/Stop Owner	129	11-59	Step 16 Value	295	11-84
Ramp/CIFlt Owner	131	11-43	Stator Resistnce	166	11-40	Step 16 Type	296	11-84
Regen Power Lim	76	11-27	Step 1 Speed	249	11-42	Stop Dwell Time	18	11-14
Relay Config 1	114	11-36	Step 1 Value	250	11-50	Test Data 1	92	11-31
Relay Config 2	187	11-56	Step 1 Type	251	11-76	Test Data 2	94	11-31
Relay Config 3	189	11-57	Step 2 Speed	252	11-77	Test Select 1	93	11-31
Relay Config 4	191	11-58	Step 2 Value	253	11-77	Test Select 2	95	11-32
Relay Setpoint 1	115	11-37	Step 2 Type	254	11-77	Torque Limit Sts	87	11-30
Relay Setpoint 2	188	11-56	Step 3 Speed	255	11-77	Torque Ref 1	69	11-26
Relay Setpoint 3	190	11-57	Step 3 Value	256	11-77	Total Inertia	157	11-48
Relay Setpoint 4	192	11-58	Step 3 Type	257	11-77	Trans Dgn Config	172	11-51
Reserved	163	11-49	Step 4 Speed	258	11-77	Units Traveled	246	11-76
Reserved	56	11-23	Step 4 Value	259	11-77	Value Tolerance	244	11-75
Reserved	57	11-23	Step 4 Type	260	11-70	Vd Max	170	11-51
Reserved	218	11-70	Step 5 Speed	261	11-78	Vq Max	171	11-51
Rev Speed Limit	40	11-20	Step 5 Value	262	11-78	Warning Select 1	21	11-16
Run Inhibit Sts	16	11-14	Step 5 Type	263	11-78	Warning Select 2	23	11-17
S-Curve Percent	47	11-21	Step 6 Speed	264	11-79	Warning Status 1	223	11-71
Scaled Spd Fdbk	63	11-24	Step 6 Value	265	11-79	Warning Status 2	224	11-72
Service Factor	9	11-11	Step 6 Type	266	11-79	Zero Speed Tol	19	11-15

## Parameter Conventions

The remainder of this chapter describes the parameters available for the 1336 IMPACT drive. Parameter descriptions follow these conventions.

Par#	Parameter Name	Parameter Number	#
	Parameter Description	<b>File: group</b>	file and group
		<b>Parameter type</b>	destination or source
		<b>Display</b>	user units
		<b>Factory default</b>	drive factory setting
		<b>Minimum Value</b>	minimum value acceptable
		<b>Maximum value</b>	maximum value acceptable
		<b>Conversion</b>	drive units = display units
		<b>Enums</b>	values

- 1 **Parameter number:** Each parameter is assigned a unique number. The number is used to read or write information to and from that parameter.
- 2 **File:group:** This lists the file and group where the parameter is located. A parameter may be listed in more than one file and group. Other parameters may not be listed in any file or group and must be accessed through the linear list.
- 3 **Parameter type:** Three types of parameters are available:  
*source:* The value is changed only by the drive and is used to monitor values.  
*destination:* The value is changed through programming. Destinations are constant values.  
*linkable destination:* This value can be either links to another parameter or a constant value.
- 4 **Display:** These are the units that you see on the HIM display, such as bits, Hz, seconds, volts, etc.
- 5 **Factory default:** This is the value assigned to each parameter at the factory. The factory default for source parameters is listed as not applicable because source parameters receive their values from other parameters.
- 6 **Minimum value:** This is the lowest setting possible for the parameter.
- 7 **Maximum value:** This is the highest setting possible for the parameter.
- 8 **Conversion:** These are internal units used to communicate through the serial port and to scale values properly when reading or writing to the drive.
- 9 **Enums:** These are the textual descriptions that are associated with individual bits.



*In the following descriptions, base motor speed is equal to the value of Nameplate RPM (parameter 3).*

1	<b>Language Select</b>	<p>Use <i>Language Select</i> to choose between a primary language and an alternate language. Select:</p> <ul style="list-style-type: none"> <li>• 0 to choose the primary language</li> <li>• 1 to choose the alternate language</li> </ul>	<p><b>Parameter number</b> 1  <b>File:group</b> none  <b>Parameter type</b> linkable destination  <b>Display</b> x  <b>Factory default</b> 0  <b>Minimum value</b> 0  <b>Maximum value</b> 1  <b>Conversion</b> 1 = 1</p>
2	<b>Nameplate HP</b>	<p><i>Nameplate HP</i> contains the value of the motor horsepower that you entered during the start up routine. This value is typically located on the motor nameplate.</p>	<p><b>Parameter number</b> 2  <b>File:group</b> Motor/Inverter:Motor Nameplate  <b>Parameter type</b> destination  <b>Display</b> x .x hp  <b>Factory default</b> 30.0 hp  <b>Minimum value</b> 0.2 hp  <b>Maximum value</b> 2000.0 hp  <b>Conversion</b> 10 = 1.0</p>
3	<b>Nameplate RPM</b>	<p><i>Nameplate RPM</i> contains the value of the motor speed that you entered during the start up routine. This value is typically located on the motor nameplate. This value should not be the synchronous speed of the motor.</p>	<p><b>Parameter number</b> 3  <b>File:group</b> Motor/Inverter:Motor Nameplate  <b>Parameter type</b> destination  <b>Display</b> x rpm  <b>Factory default</b> 1750 rpm  <b>Minimum value</b> 1 rpm  <b>Maximum value</b> 15000 rpm  <b>Conversion</b> 1 = 1</p>
4	<b>Nameplate Amps</b>	<p><i>Nameplate Amps</i> contains the value of the current rating of the motor that you entered during the start up routine. This value is typically located on the motor nameplate. The drive uses this information to properly tune to the motor.</p>	<p><b>Parameter number</b> 4  <b>File:group</b> Motor/Inverter:Motor Nameplate  <b>Parameter type</b> destination  <b>Display</b> x.x amps  <b>Factory default</b> 0.2 amps  <b>Minimum value</b> 0.1 amps  <b>Maximum value</b> calculated  <b>Conversion</b> 10 = 1.0</p>
5	<b>Nameplate Volts</b>	<p><i>Nameplate Volts</i> contains the voltage rating of the motor that you entered during the start up routine. This value is typically located on the motor nameplate.</p>	<p><b>Parameter number</b> 5  <b>File:group</b> Motor/Inverter:Motor Nameplate  <b>Parameter type</b> destination  <b>Display</b> x volt  <b>Factory default</b> 460 volts  <b>Minimum value</b> 75 volts  <b>Maximum value</b> 575 volts  <b>Conversion</b> 1 = 1</p>
6	<b>Nameplate Hz</b>	<p><i>Nameplate Hz</i> contains the value of the frequency rating of the motor that you entered during the start up routine. This value is typically located on the motor nameplate.</p>	<p><b>Parameter number</b> 6  <b>File:group</b> Motor/Inverter:Motor Nameplate  <b>Parameter type</b> destination  <b>Display</b> x.x Hz  <b>Factory default</b> 60.0 Hz  <b>Minimum value</b> 1.0 Hz  <b>Maximum value</b> 250.0 Hz  <b>Conversion</b> 10 = 1.0</p>



7	<b>Motor Poles</b> <i>Motor Poles</i> contains the number of motor poles. The drive calculates this value during the Quick Motor Tune portion of the start up routine.  Note: <u>Encoder PPR</u> # of Motor Poles Must be greater than 64	<b>Parameter number</b> <b>File:group</b> <b>Parameter type</b> <b>Display</b> <b>Factory default</b> <b>Minimum value</b> <b>Maximum value</b> <b>Conversion</b>	7 Motor/Inverter:Motor Nameplate Motor/Inverter:Motor Constants destination x poles 4 poles 2 poles 40 poles 1 = 1
8	<b>Encoder PPR</b> <i>Encoder PPR</i> contains the pulse per revolution rating of the feedback device when you use an encoder to determine motor speed.  Note: <u>Encoder PPR</u> # of Motor Poles Must be greater than 64	<b>Parameter number</b> <b>File:group</b> <b>Parameter type</b> <b>Display</b> <b>Factory default</b> <b>Minimum value</b> <b>Maximum value</b> <b>Conversion</b>	8 Motor/Inverter:Encoder Data Control:Feedback Device destination x ppr 1024 ppr calculated 20000 ppr 1 = 1
9	<b>Service Factor</b> Enter the minimum level of current that causes a motor overload ( $I^2T$ ) trip under continuous operation. Current levels below this value never result in an overload trip. For example, a service factor of 1.15 implies continuous operation up to 115% of nameplate motor current.	<b>Parameter number</b> <b>File:group</b> <b>Parameter type</b> <b>Display</b> <b>Factory default</b> <b>Minimum value</b> <b>Maximum value</b> <b>Conversion</b>	9 Motor/Inverter:Motor Nameplate destination x.xx 1.15 1.00 2.00 4096 = 1.00
10	<b>PWM Frequency</b> Enter the drive carrier frequency in Hz. The drive carrier frequency depends on your application and drive size. The drive carrier frequency affects the audible noise level of your motor.	<b>Parameter number</b> <b>File:group</b> <b>Parameter type</b> <b>Display</b> <b>Factory default</b> <b>Minimum value</b> <b>Maximum value</b> <b>Conversion</b>	10 Motor/Inverter:Inverter destination x Hz 4000 Hz 1000 Hz from the drive type 1 = 1
11	<b>Inverter Amps</b> <i>Inverter Amps</i> provides the current rating of the inverter. The drive automatically sets <i>Inverter Amps</i> at power up.	<b>Parameter number</b> <b>File:group</b> <b>Parameter type</b> <b>Display</b> <b>Factory default</b> <b>Minimum value</b> <b>Maximum value</b> <b>Conversion</b>	11 Motor/Inverter:Inverter source x.x amps not applicable 0.1 amps from drive type 10 = 1.0
12	<b>Inverter Volts</b> <i>Inverter Volts</i> is the drive nameplate voltage rating of the inverter. The drive automatically sets <i>Inverter Volts</i> at power up.	<b>Parameter number</b> <b>File:group</b> <b>Parameter type</b> <b>Display</b> <b>Factory default</b> <b>Minimum value</b> <b>Maximum value</b> <b>Conversion</b>	12 Motor/Inverter:Inverter source x volts not applicable 75 volts 575 volts 1 = 1

**13 Bus/Brake Opts**

*Bus/Brake Opts* lets you choose options for the bus filter reference, precharge/ridethrough conditions, and braking.

Use bits 0 through 4 to set the slew rate for the bus voltage tracker. The bus voltage tracker slowly tracks changes in the actual bus voltage. If the actual bus voltage drops 150 volts or more below the current value of the bus voltage tracker, the drive automatically disables modulation and enters precharge. Bits 0 through 4 select the sensitivity of the bus voltage tracker to changes in the actual bus voltage. If none of the bits (0 through 4) are set, the slew rate is 0.05V/second.

The precharge function of the drive limits the current to the bus capacitors when power is initially applied to the drive. The precharge function is completed after a minimum 300 millisecond time delay and bus voltage at least 30 volts greater than the undervoltage setpoint and a stable bus voltage. Ridethrough provides extended logic operating time if the power lines drop out while the drive is running. If the precharge function is enabled, ridethrough also provides inrush current protection by starting a precharge, in case the incoming power returns.

The bits are defined as follows:

Bit	Description
0	<b>Slew Rate 1</b> Set to choose a slew rate of 10V/second.
1	<b>Slew Rate 2</b> Set to choose a slew rate of 5V/second.
2	<b>Slew Rate 3</b> Set to choose a slew rate of 0.5V/second.
3	<b>Slew Rate 4</b> Set to choose a slew rate of 0.05V/second.
4	<b>Slew Rate 5</b> Set to choose a slew rate of 0.005V/second.
5	<b>Bus High Lim</b> Set this bit only when bit 10 is set and the brake used on the drive is undersized. Refer to Chapter 9, <i>Applications</i> .
6	<b>Flux Braking</b> Set to use an increase in the motor flux current to increase the motor losses and allow a faster deceleration time when there is no chopper brake or regenerative capability.
7	<b>DC Hold</b> Set to enable DC hold. This applies DC current to the motor to attempt to hold zero speed in encoderless operation when the drive is stopped.

Parameter number	13
<b>File:group</b>	Application:Flux Braking Application:DC Braking/Hold Application:Fast Flux Up Application:Bus Reg/Control
<b>Parameter type</b>	linkable destination
<b>Display</b>	bits
<b>Factory default</b>	00000000.00000000
<b>Minimum value</b>	00000000.00000000
<b>Maximum value</b>	11111111.11111111
<b>Conversion</b>	1 = 1

For additional information about *Bus/Brake Opts*, refer to Chapter 9, *Applications* and Chapter 12, *Troubleshooting*.

**Important:** If you add a dynamic brake after completing the drive start up, you must run start up again or manually adjust *Regen Power Lim* (parameter 76) to the proper value. If you do not, the drive will be limited to 25% regen.

Bit	Description
8	<b>Fast Fluxup</b> Set to enable fast flux up. <i>Fast Flux Level</i> (parameter 78) set the level of current used to build flux in the motor.
9	<b>DC Braking</b> Set to apply DC current to the motor when a stop is commanded. <i>DC Brake Current</i> (parameter 79) sets the level, and <i>DC Brake Time</i> (parameter 80) sets the time
10	<b>Brake/Regen</b> Set to indicate that a chopper brake, common bus, or regenerative capability is present. 0 = The bus voltage controller is on. 1 = The bus voltage controller is off unless bit 5 is set (1). Refer to Chapter 9, <i>Applications</i> .
11	<b>Prech Exit</b> Set to force an exit from precharge after the precharge timeout.
12	<b>En Comm Bus</b> Set to enable common bus precharge. External fault input is used as precharge enable.
13	<b>Dis Prech Tm</b> Set to disable bus precharge and undervoltage faults while the drive is disabled.
14	<b>Dis Mult Pre</b> Set to disable all precharges after the first power up.
15	<b>Dis Ridethru</b> Set to disable all ridethroughs.

**14 Logic Input Sts**

Use *Logic Input Sts* to view drive logic operation. If a bit is set (1), that function is enabled. If a bit is clear (0), that function is disabled (not active).

The bits are defined as follows:

Bit	Description
0	<b>Normal Stop</b> A ramp stop is selected.
1	<b>Start</b> A start is in progress.
2	<b>Jog 1</b> A jog 1 is in progress.
3	<b>Clear Fault</b> A clear fault is in progress.
4	<b>Forward</b> A forward was commanded.

Bit	Description
5	<b>Reverse</b> A reverse was commanded.
6	<b>Jog 2</b> A jog 2 is in progress.
7	<b>Cur Lim Stop</b> A current limit stop is selected.
8	<b>Coast Stop</b> A coast stop is selected.
9	<b>Spd Ramp Dis</b> Ramps are disabled.

Bit	Description
10	<b>Flux Enable</b> Flux is enabled.
11	<b>Process Trim</b> Process trim is enabled.
12	<b>Speed Ref A</b>
13	<b>Speed Ref B</b>
14	<b>Speed Ref C</b>
15	<b>Reset Drive</b> The drive has been commanded to reset.

C	B	A	
0	0	0	No Change
0	0	1	Speed Ref 1
0	1	0	Speed Ref 2
0	1	1	Speed Ref 3
1	0	0	Speed Ref 4
1	0	1	Speed Ref 5
1	1	0	Speed Ref 6
1	1	1	Speed Ref 7

<b>Parameter number</b>	14
<b>File:group</b>	Monitor:Drive/Inv Status
<b>Parameter type</b>	source
<b>Display</b>	bits
<b>Factory default</b>	not applicable
<b>Minimum value</b>	00000000.00000000
<b>Maximum value</b>	11111111.11111111
<b>Conversion</b>	1 = 1

**15 Drive/Inv Status**

Use *Drive/Inv Status* to view the status/conditions within the drive. When a bit is set (1), the corresponding condition in the drive is true.

The bits are defined as follows:

Bit	Description
0	<b>Run Ready</b> The drive is ready to run. No bits are set in <i>Run Inhibit Sts</i> (parameter 16)
1	<b>Running</b> The drive is following a speed/torque reference
2	<b>Command Dir</b> Shows which direction has been requested; 1 is forward, and 0 is reverse.
3	<b>Rotating Dir</b> Shows the direction that the motor is currently rotating; 1 is forward, and 0 is reverse.

Bit	Description
4	<b>Accelerating</b> If 1, the motor is accelerating.
5	<b>Decelerating</b> If 1, the motor is decelerating.
6	<b>Warning</b> If 1, a warning has occurred. <sup>1</sup>
7	<b>Faulted</b> If 1, a fault has occurred. <sup>2</sup>
8	<b>At Set Speed</b> The motor is at the requested speed.
9	<b>Enable LED</b> The drive is enabled.

Bit	Description
10	<b>Stopped</b> If 1, the drive is stopped.
11	<b>Stopping</b> If 1, the drive is stopping.
12	<b>At Zero Spd</b> Corresponds to <i>Zero Speed Tol</i> (parameter 19).
13	<b>Speed Ref A</b>
14	<b>Speed Ref B</b>
15	<b>Speed Ref C</b>

C	B	A	
0	0	0	No Change
0	0	1	Speed Ref 1
0	1	0	Speed Ref 2
0	1	1	Speed Ref 3
1	0	0	Speed Ref 4
1	0	1	Speed Ref 5
1	1	0	Speed Ref 6
1	1	1	Speed Ref 7

<b>Parameter number</b>	15
<b>File:group</b>	Monitor:Drive/Inv Status
<b>Parameter type</b>	source
<b>Display</b>	bits
<b>Factory default</b>	not applicable
<b>Minimum value</b>	00000000.00000000
<b>Maximum value</b>	11111111.11111111
<b>Conversion</b>	1 = 1

<sup>1</sup> If a warning has occurred, check the warning queue for more information.

<sup>2</sup> If a fault has occurred, check the fault queue for more information.

<b>16</b>	<b>Run Inhibit Sts</b>	<p>View <i>Run Inhibit Sts</i> to determine what condition is actively preventing the drive from starting or running. If all bits are clear (0), the drive should start. If the drive is running and this word becomes non-zero, the drive will stop.</p> <p>The bits are defined as follows:</p>	<table border="0"> <tr> <td><b>Parameter number</b></td> <td style="text-align: right;">16</td> </tr> <tr> <td><b>File:group</b></td> <td style="text-align: right;">Monitor:Drive/Inv Status</td> </tr> <tr> <td><b>Parameter type</b></td> <td style="text-align: right;">source</td> </tr> <tr> <td><b>Display</b></td> <td style="text-align: right;">bits</td> </tr> <tr> <td><b>Factory default</b></td> <td style="text-align: right;">not applicable</td> </tr> <tr> <td><b>Minimum value</b></td> <td style="text-align: right;">00000000.00000000</td> </tr> <tr> <td><b>Maximum value</b></td> <td style="text-align: right;">11111111.11111111</td> </tr> <tr> <td><b>Conversion</b></td> <td style="text-align: right;">1 = 1</td> </tr> </table>	<b>Parameter number</b>	16	<b>File:group</b>	Monitor:Drive/Inv Status	<b>Parameter type</b>	source	<b>Display</b>	bits	<b>Factory default</b>	not applicable	<b>Minimum value</b>	00000000.00000000	<b>Maximum value</b>	11111111.11111111	<b>Conversion</b>	1 = 1
<b>Parameter number</b>	16																		
<b>File:group</b>	Monitor:Drive/Inv Status																		
<b>Parameter type</b>	source																		
<b>Display</b>	bits																		
<b>Factory default</b>	not applicable																		
<b>Minimum value</b>	00000000.00000000																		
<b>Maximum value</b>	11111111.11111111																		
<b>Conversion</b>	1 = 1																		

Bit	Description	Bit	Description	Bit	Description
0	<b>Atune Mode</b> The drive is currently in auto-tune.	5	<b>No Enable</b> No hardware drive enable input.	11	<b>Reserved</b> Leave 0.
1	<b>Precharge</b> The drive stopped & is in bus precharge.	6	<b>Flux Loss</b> The drive dropped the drive enable acknowledgement.	12	<b>EE Function</b> The drive stopped and an EE function is active.
2	<b>Coast Stop</b> Coast stop input (discrete or software).	7	<b>Reserved</b> Leave 0.	13	<b>Atune Stop</b> Auto-tune stop.
3	<b>Extern Fault</b> External input open.	8	<b>Hrdware Stop</b> Any hardware stop input.	14	<b>Diag Stop</b> Drive diagnostic inhibit.
4	<b>Coast Fault</b> A coast fault condition occurred.	9	<b>Sftware Stop</b> Any software stop input.	15	<b>Drive Fault</b> Any fault condition.
		10	<b>Start/Jog</b> Start and/or jog is set.		

<b>17</b>	<b>Logic Options</b>	<p>Use <i>Logic Options</i> to select the options for logic operation of the drive.</p> <p>If you set bits 1, 2, and 3, the drive performs a coast to stop. For additional information about the stop types and priorities, refer to Appendix B, <i>Control Block Diagrams</i>.</p> <p>The bits are defined as follows:</p>	<table border="0"> <tr> <td><b>Parameter number</b></td> <td style="text-align: right;">17</td> </tr> <tr> <td><b>File:group</b></td> <td style="text-align: right;">Control:Drive Logic Select</td> </tr> <tr> <td><b>Parameter type</b></td> <td style="text-align: right;">linkable destination</td> </tr> <tr> <td><b>Display</b></td> <td style="text-align: right;">bits</td> </tr> <tr> <td><b>Factory default</b></td> <td style="text-align: right;">00010000.00001000</td> </tr> <tr> <td><b>Minimum value</b></td> <td style="text-align: right;">00000000.00000000</td> </tr> <tr> <td><b>Maximum value</b></td> <td style="text-align: right;">01111111.11111111</td> </tr> <tr> <td><b>Conversion</b></td> <td style="text-align: right;">1 = 1</td> </tr> </table>	<b>Parameter number</b>	17	<b>File:group</b>	Control:Drive Logic Select	<b>Parameter type</b>	linkable destination	<b>Display</b>	bits	<b>Factory default</b>	00010000.00001000	<b>Minimum value</b>	00000000.00000000	<b>Maximum value</b>	01111111.11111111	<b>Conversion</b>	1 = 1
<b>Parameter number</b>	17																		
<b>File:group</b>	Control:Drive Logic Select																		
<b>Parameter type</b>	linkable destination																		
<b>Display</b>	bits																		
<b>Factory default</b>	00010000.00001000																		
<b>Minimum value</b>	00000000.00000000																		
<b>Maximum value</b>	01111111.11111111																		
<b>Conversion</b>	1 = 1																		

Bit	Description	Bit	Description	Bit	Description
0	<b>Reserved</b> Leave 0.	7	<b>Jog Coast</b> 1 selects jog coast. 0 selects regen stop.	12	<b>Coast Stop 2</b> Set to use a coast to stop. Only used when <i>L Option Mode</i> (par. 116) is 3, 13, or 16.
1	<b>Coast Stop 1</b> Set to use a coast to stop.	8	<b>Start Diag</b> Do diagnostics each time the drive is started.	13	<b>CurLim Stop 2</b> Set to use a current limit to stop. Only used when <i>L Option Mode</i> (par. 116) is 3, 13, or 16.
2	<b>CurLim Stop 1</b> Set to use a current limit to stop.	9	<b>Pwr Up Start</b> Set to enable the auto start feature on power up if a start is valid.	14	<b>Ramp Stop 2</b> Set to use a ramp to stop. Only used when <i>L Option Mode</i> (par. 116) is 3, 13, or 16.
3	<b>Ramp Stop 1</b> Set to use a ramp to stop.			15	<b>Reserved</b> Leave 0.
4 – 5	<b>Reserved</b> Leave 0.	10	<b>Reserved</b> Leave 0.		
6	<b>Jog Ramp En</b> Set to enable the jog ramp.	11	<b>Bipolar Sref</b> 1 selects bipolar reference. 0 selects unipolar reference.		

<b>18</b>	<b>Stop Dwell Time</b>	<p>Use <i>Stop Dwell Time</i> to set an adjustable delay time before the drive disables speed and torque regulators when a stop has been initiated.</p>	<table border="0"> <tr> <td><b>Parameter number</b></td> <td style="text-align: right;">18</td> </tr> <tr> <td><b>File:group</b></td> <td style="text-align: right;">Control:Drive Logic Select</td> </tr> <tr> <td><b>Parameter type</b></td> <td style="text-align: right;">linkable destination</td> </tr> <tr> <td><b>Display</b></td> <td style="text-align: right;">x.x seconds</td> </tr> <tr> <td><b>Factory default</b></td> <td style="text-align: right;">0.0 seconds</td> </tr> <tr> <td><b>Minimum value</b></td> <td style="text-align: right;">0.0 seconds</td> </tr> <tr> <td><b>Maximum value</b></td> <td style="text-align: right;">10.0 seconds</td> </tr> <tr> <td><b>Conversion</b></td> <td style="text-align: right;">10 = 1.0</td> </tr> </table>	<b>Parameter number</b>	18	<b>File:group</b>	Control:Drive Logic Select	<b>Parameter type</b>	linkable destination	<b>Display</b>	x.x seconds	<b>Factory default</b>	0.0 seconds	<b>Minimum value</b>	0.0 seconds	<b>Maximum value</b>	10.0 seconds	<b>Conversion</b>	10 = 1.0
<b>Parameter number</b>	18																		
<b>File:group</b>	Control:Drive Logic Select																		
<b>Parameter type</b>	linkable destination																		
<b>Display</b>	x.x seconds																		
<b>Factory default</b>	0.0 seconds																		
<b>Minimum value</b>	0.0 seconds																		
<b>Maximum value</b>	10.0 seconds																		
<b>Conversion</b>	10 = 1.0																		

<b>19</b>	<b>Zero Speed Tol</b> Use <i>Zero Speed Tol</i> to establish a band around zero speed that is used to determine when the drive considers the motor to be at zero speed. Bit 12 (At Zero Spd) in <i>Drive/Inv Status</i> (parameter 15) indicates this.	<b>Parameter number</b>	19
		<b>File:group</b>	Control:Drive Logic Select
		<b>Parameter type</b>	linkable destination
		<b>Display</b>	x.x rpm
		<b>Factory default</b>	base motor speed/100 rpm
		<b>Minimum value</b>	0.0 rpm
		<b>Maximum value</b>	8 x base motor speed rpm
<b>Conversion</b>	4096 = base motor speed		

<b>20</b>	<b>Fault Select 1</b> Use <i>Fault Select 1</i> to specify how the drive should handle certain conditions. Each bit within this parameter matches the bit definitions of <i>Warning Select 1</i> (parameter 21). If you set bit(s) to 1 in this parameter, the drive reports a fault when that condition occurs. If you clear bit(s) to 0, the drive reports the condition based on <i>Warning Select 1</i> .  The bits are defined as follows:	<b>Parameter number</b>	20
		<b>File:group</b>	Fault Setup:Fault Config
		<b>Parameter type</b>	linkable destination
		<b>Display</b>	bits
		<b>Factory default</b>	01111110.00100011
		<b>Minimum value</b>	00000000.00000000
		<b>Maximum value</b>	01111111.00111111
<b>Conversion</b>	1 = 1		
		Refer to Chapter 12, <i>Troubleshooting</i> , for additional information.	

Bit	Description	Bit	Description	Bit	Description
0	<b>RidethruTime</b> A bus ridethrough timeout occurred.	6 – 7	<b>Reserved</b> Leave 0.	12	<b>SP 4 Timeout</b> Loss of communication with SCANport device 4 occurred.
1	<b>Prechrg Time</b> A bus precharge timeout occurred.	8	<b>mA Input</b> A loss of input connection occurred after it was established.	13	<b>SP 5 Timeout</b> Loss of communication with SCANport device 5 occurred.
2	<b>Bus Drop</b> A bus drop of 150 volts occurred.	9	<b>SP 1 Timeout</b> Loss of communication with SCANport device 1 occurred.	14	<b>SP 6 Timeout</b> Loss of communication with SCANport device 6 occurred.
3	<b>Bus Undervlt</b> A bus undervoltage occurred.	10	<b>SP 2 Timeout</b> Loss of communication with SCANport device 2 occurred.	15	<b>SP Error</b> Too many errors on the SCANport communication.
4	<b>Bus Cycles&gt;5</b> More than 5 ridethroughs occurred in a row.	11	<b>SP 3 Timeout</b> Loss of communication with SCANport device 3 occurred.		
5	<b>Open Circuit</b> Fast flux up current is <50%.				

## 21 Warning Select 1

Use *Warning Select 1* to specify how the drive should handle certain conditions. Each bit within this parameter matches the bit definitions of *Fault Select 1* (parameter 20). If you set a bit to 1 and the corresponding bit in *Fault Select 1* is clear (0), the drive reports a warning when that condition occurs. If both corresponding bits in *Fault Select 1* and *Warning Select 1* are 0, the drive ignores the condition when it occurs.

The bits are defined as follows:

Bit	Description
0	<b>RidethruTime</b> A bus ridethrough timeout occurred.
1	<b>Prechrg Time</b> A bus precharge timeout occurred.
2	<b>Bus Drop</b> A bus drop of 150 volts occurred.
3	<b>Bus Undervlt</b> A bus undervoltage occurred.
4	<b>Bus Cycles&gt;5</b> More than 5 ridethroughs occurred in a row.
5	<b>Open Circuit</b> Fast flux up current is <50%.

Bit	Description
6 – 7	<b>Reserved</b> Leave 0.
8	<b>mA Input</b> A loss of input connection occurred after it was established.
9	<b>SP 1 Timeout</b> Loss of communication with SCANport device 1 occurred.
10	<b>SP 2 Timeout</b> Loss of communication with SCANport device 2 occurred.
11	<b>SP 3 Timeout</b> Loss of communication with SCANport device 3 occurred.

<b>Parameter number</b>	21
<b>File:group</b>	Fault Setup:Fault Config
<b>Parameter type</b>	linkable destination
<b>Display</b>	bits
<b>Factory default</b>	00000000.00011100
<b>Minimum value</b>	00000000.00000000
<b>Maximum value</b>	01111111.00111111
<b>Conversion</b>	1 = 1

Refer to Chapter 12, *Troubleshooting*, for additional information.

## 22 Fault Select 2

Use *Fault Select 2* to specify how the drive should handle certain conditions. Each bit matches the bit definitions of *Warning Select 2* (parameter 23). If you set a bit to 1, the drive reports a fault when that condition occurs. If you clear a bit to 0, the drive reports the condition based on *Warning Select 2*.

The bits are defined as follows:

Bit	Description
0	<b>SpdFdbk Loss</b> A loss of feedback occurred.
1	<b>InvOvtmp Pnd</b> An inverter overtemp is pending.
2	<b>Reserved</b> Leave 0.
3	<b>MtrOvld Pend</b> A motor overload is pending ( $I^2T$ ).
4	<b>MtrOvld Trip</b> Motor overload trip ( $I^2T$ )

Bit	Description
5	<b>Mtr Stall</b> The motor stalled.
6	<b>Ext Fault In</b> The ext input is open.
7 – 8	<b>Reserved</b> Leave 0.
9	<b>Param Limit</b> A parameter is out of limits
10	<b>Math Limit</b> A math limit occurred.

<b>Parameter number</b>	22
<b>File:group</b>	Fault Setup:Fault Config
<b>Parameter type</b>	linkable destination
<b>Display</b>	bits
<b>Factory default</b>	10000000.00010001
<b>Minimum value</b>	00000000.00000000
<b>Maximum value</b>	11111111.11111111
<b>Conversion</b>	1 = 1

Refer to Chapter 12, *Troubleshooting*, for additional information.

<b>23</b>	<b>Warning Select 2</b>	<p>Use <i>Warning Select 2</i> to specify how the drive should handle certain conditions. Each bit matches the bit definitions of <i>Fault Select 2</i> (parameter 22). If you set a bit to 1 and the corresponding bit in <i>Fault Select 2</i> is clear (0), the drive reports a warning when that condition occurs. If both corresponding bits in <i>Fault Select 2</i> and <i>Warning Select 2</i> are 0, the drive ignores the condition when it occurs.</p> <p>The bits are defined as follows:</p>	<b>Parameter number</b>	23	
			<b>File:group</b>	Fault Setup:Fault Config	
			<b>Parameter type</b>	linkable destination	
			<b>Display</b>	bits	
			<b>Factory default</b>	10100000.00001010	
			<b>Minimum value</b>	00000000.00000000	
			<b>Maximum value</b>	11111111.11111111	
			<b>Conversion</b>	1 = 1	
			Refer to Chapter 12, <i>Troubleshooting</i> , for additional information.		
<b>Bit</b>	<b>Description</b>	<b>Bit</b>	<b>Description</b>	<b>Bit</b>	<b>Description</b>
0	<b>SpdFdbk Loss</b> A loss of feedback occurred.	5	<b>Mtr Stall</b> The motor stalled.	11 – 12	<b>Reserved</b> Leave 0.
1	<b>InvOvtmp Pnd</b> An inverter overtemp is pending.	6	<b>Ext Fault In</b> The ext input is open.	13	<b>InvOvld Pnd</b> An inverter overload is pending (IT).
2	<b>Reserved</b> Leave 0.	7 – 8	<b>Reserved</b> Leave 0.	14	<b>Reserved</b> Leave 0.
3	<b>MtrOvld Pnd</b> A motor overload is pending (I <sup>2</sup> T).	9	<b>Param Limit</b> A parameter is out of limits	15	<b>InvOvld Trip</b> Inverter overload trip (IT)
4	<b>MtrOvld Trip</b> Motor overload trip (I <sup>2</sup> T)	10	<b>Math Limit</b> A math limit occurred.		
<b>24</b>	<b>Absolute Overspd</b>	<p>Enter the incremental speed above <i>Fwd Speed Limit</i> (parameter 41) or below <i>Rev Speed Limit</i> (parameter 40) that is allowable before the drive indicates its speed is out of range, an <i>Absolute Overspd</i> fault (fault number 03025).</p>	<b>Parameter number</b>	24	
			<b>File:group</b>	Fault Setup:Fault Limits	
			<b>Parameter type</b>	linkable destination	
			<b>Display</b>	x.x rpm	
			<b>Factory default</b>	base motor speed x 0.1 rpm	
			<b>Minimum value</b>	0.0 rpm	
			<b>Maximum value</b>	base motor speed rpm	
			<b>Conversion</b>	4096 = 100% overspeed	
<b>25</b>	<b>Motor Stall Time</b>	<p>Enter the length of time that the drive must be in current limit and at zero speed before the drive indicates a <i>Mtr Stall</i> fault (fault number 01053). You can use bit 5 of <i>Fault Select 2</i> (parameter 22) and <i>Warning Select 2</i> (parameter 23) to configure how the drive should report a <i>Mtr Stall</i> fault.</p>	<b>Parameter number</b>	25	
			<b>File:group</b>	Fault Setup:Fault Limits	
			<b>Parameter type</b>	linkable destination	
			<b>Display</b>	x.x seconds	
			<b>Factory default</b>	1.0 seconds	
			<b>Minimum value</b>	0.1 seconds	
			<b>Maximum value</b>	3276.7 seconds	
			<b>Conversion</b>	10 = 1.0	
<b>26</b>	<b>Motor Overload %</b>	<p>Enter the level of current that will cause a <i>Motor Overld Trp</i> fault (fault number 01052) after 60 seconds. You can use bit 4 of <i>Fault Select 2</i> (parameter 22) and <i>Warning Select 2</i> (parameter 23) to configure how the drive should report a <i>Motor Overld Trp</i>.</p>	<b>Parameter number</b>	26	
			<b>File:group</b>	Fault Setup:Fault Limits	
			<b>Parameter type</b>	linkable destination	
			<b>Display</b>	x.x%	
			<b>Factory default</b>	200.0%	
			<b>Minimum value</b>	110.0%	
			<b>Maximum value</b>	400.0%	
			<b>Conversion</b>	4096 = 100% Iq for 60 seconds	
<b>27</b>	<b>Line Undervolts</b>	<p>Enter the minimum threshold as a percentage of the line voltage that is compared with <i>DC Bus Voltage</i> (parameter 84) as a check for a bus undervoltage condition.</p>	<b>Parameter number</b>	27	
			<b>File:group</b>	Fault Setup:Fault Limits	
			<b>Parameter type</b>	linkable destination	
			<b>Display</b>	x.x%	
			<b>Factory default</b>	61.5%	
			<b>Minimum value</b>	10.0%	
			<b>Maximum value</b>	90.0%	
			<b>Conversion</b>	1024 = 100.0%	
			Refer to Chapter 12, <i>Troubleshooting</i> , for additional information.		

<b>28</b>	<b>Speed Ref 1 Frac</b>	Use <i>Speed Ref 1 Frac</i> to supply the fractional part of the external speed reference 1 when speed reference is selected in <i>Logic Input Sts</i> (parameter 14).	<b>Parameter number</b> 28 <b>File:group</b> none <b>Parameter type</b> linkable destination <b>Display</b> x <b>Factory default</b> 0 <b>Minimum value</b> 0 <b>Maximum value</b> 65535 <b>Conversion</b> 1 = 1/2 <sup>28</sup> base motor speed
<b>29</b>	<b>Speed Ref 1</b>	Enter the speed reference that the drive should use when speed reference 1 is selected in <i>Logic Input Sts</i> (parameter 14). <i>Speed Ref 1</i> supplies the whole number portion of the speed reference. You can use <i>Speed Ref 1 Frac</i> (parameter 28) to specify the fractional portion of the speed reference.	<b>Parameter number</b> 29 <b>File:group</b> Control:Speed Reference <b>Parameter type</b> linkable destination <b>Display</b> ±x.x rpm <b>Factory default</b> 0.0 rpm <b>Minimum value</b> -8 x base motor speed rpm <b>Maximum value</b> +8 x base motor speed rpm <b>Conversion</b> 4096 = base motor speed
<b>30</b>	<b>Speed Scale 1</b>	Enter the gain multiplier used to scale speed reference 1.	<b>Parameter number</b> 30 <b>File:group</b> Control:Speed Reference <b>Parameter type</b> linkable destination <b>Display</b> ±x.xxxx <b>Factory default</b> +1.0000 <b>Minimum value</b> -3.9999 <b>Maximum value</b> +3.9999 <b>Conversion</b> 8192 = 1.0000
<b>31</b>	<b>Speed Ref 2</b>	Enter the speed reference that the drive should use when speed reference 2 is selected in <i>Logic Input Sts</i> (parameter 14).	<b>Parameter number</b> 31 <b>File:group</b> Control:Speed Reference <b>Parameter type</b> linkable destination <b>Display</b> ±x.x rpm <b>Factory default</b> 0.0 rpm <b>Minimum value</b> -8 x base motor speed rpm <b>Maximum value</b> +8 x base motor speed rpm <b>Conversion</b> 4096 = base motor speed
<b>32</b>	<b>Speed Ref 3</b>	Enter the speed reference that the drive should use when speed reference 3 is selected in <i>Logic Input Sts</i> (parameter 14).	<b>Parameter number</b> 32 <b>File:group</b> Control:Speed Reference <b>Parameter type</b> linkable destination <b>Display</b> ±x.x rpm <b>Factory default</b> +0.0 rpm <b>Minimum value</b> -8 x base motor speed rpm <b>Maximum value</b> +8 x base motor speed rpm <b>Conversion</b> 4096 = base motor speed
<b>33</b>	<b>Speed Ref 4</b>	Enter the speed reference that the drive should use when speed reference 4 is selected in <i>Logic Input Sts</i> (parameter 14).	<b>Parameter number</b> 33 <b>File:group</b> Control:Speed Reference <b>Parameter type</b> linkable destination <b>Display</b> ±x.x rpm <b>Factory default</b> +0.0 rpm <b>Minimum value</b> -8 x base motor speed rpm <b>Maximum value</b> +8 x base motor speed rpm <b>Conversion</b> 4096 = base motor speed



<b>34</b>	<b>Speed Ref 5</b> Enter the speed reference that the drive should use when speed reference 5 is selected in <i>Logic Input Sts</i> (parameter 14).	<b>Parameter number</b> 34 <b>File:group</b> Control:Speed Reference <b>Parameter type</b> linkable destination <b>Display</b> ±x.x rpm <b>Factory default</b> +0.0 rpm <b>Minimum value</b> -8 x base motor speed rpm <b>Maximum value</b> +8 x base motor speed rpm <b>Conversion</b> 4096 = base motor speed
<b>35</b>	<b>Speed Ref 6</b> Enter the speed reference that the drive should use when speed reference 6 is selected in <i>Logic Input Sts</i> (parameter 14).	<b>Parameter number</b> 35 <b>File:group</b> Control:Speed Reference <b>Parameter type</b> linkable destination <b>Display</b> ±x.x rpm <b>Factory default</b> +0.0 rpm <b>Minimum value</b> -8 x base motor speed rpm <b>Maximum value</b> +8 x base motor speed rpm <b>Conversion</b> 4096 = base motor speed
<b>36</b>	<b>Speed Ref 7</b> Enter the speed reference that the drive should use when speed reference 7 is selected in <i>Logic Input Sts</i> (parameter 14).	<b>Parameter number</b> 36 <b>File:group</b> Control:Speed Reference <b>Parameter type</b> linkable destination <b>Display</b> ±x.x rpm <b>Factory default</b> +0.0 rpm <b>Minimum value</b> -8 x base motor speed rpm <b>Maximum value</b> +8 x base motor speed rpm <b>Conversion</b> 4096 = base motor speed
<b>37</b>	<b>Speed Scale 7</b> Enter the gain multiplier used to scale <i>Speed Ref 7</i> (parameter 36).	<b>Parameter number</b> 37 <b>File:group</b> Control:Speed Reference <b>Parameter type</b> linkable destination <b>Display</b> ±x.xxxx <b>Factory default</b> +1.0000 <b>Minimum value</b> -3.9999 <b>Maximum value</b> +3.9999 <b>Conversion</b> 8192 = 1.0000
<b>38</b>	<b>Jog Speed 1</b> Enter the speed reference that the drive should use when Jog 1 is selected in <i>Logic Input Sts</i> (parameter 14).	<b>Parameter number</b> 38 <b>File:group</b> Control:Speed Reference <b>Parameter type</b> linkable destination <b>Display</b> ±x.x rpm <b>Factory default</b> +100.0 rpm <b>Minimum value</b> -8 x base motor speed rpm <b>Maximum value</b> +8 x base motor speed rpm <b>Conversion</b> 4096 = base motor speed
<b>39</b>	<b>Jog Speed 2</b> Enter the speed reference that the drive should use when Jog 2 is selected in <i>Logic Input Sts</i> (parameter 14).	<b>Parameter number</b> 39 <b>File:group</b> Control:Speed Reference <b>Parameter type</b> linkable destination <b>Display</b> ±x.x rpm <b>Factory default</b> +0.0 rpm <b>Minimum value</b> -8 x base motor speed rpm <b>Maximum value</b> +8 x base motor speed rpm <b>Conversion</b> 4096 = base motor speed

40	<b>Rev Speed Limit</b> Use <i>Rev Speed Limit</i> to set a limit on speed in the negative direction. Enter a negative value or zero.	<b>Parameter number</b> <b>File:group</b> <b>Parameter type</b> <b>Display</b> <b>Factory default</b> <b>Minimum value</b> <b>Maximum value</b> <b>Conversion</b>	40 Control:Control Limits destination -x.x rpm -base motor speed rpm -6 x base motor speed rpm 0.0 rpm -4096 = base motor speed
41	<b>Fwd Speed Limit</b> Use <i>Fwd Speed Limit</i> to set a limit on speed in the positive direction. Enter a positive value or zero.	<b>Parameter number</b> <b>File:group</b> <b>Parameter type</b> <b>Display</b> <b>Factory default</b> <b>Minimum value</b> <b>Maximum value</b> <b>Conversion</b>	41 Control:Control Limits destination x.x rpm +base motor speed rpm 0.0 rpm +6 x base motor speed rpm +4096 = base motor speed
42	<b>Accel Time 1</b> Enter the length of time for the drive to ramp from 0 rpm to the base speed.	<b>Parameter number</b> <b>File:group</b> <b>Parameter type</b> <b>Display</b> <b>Factory default</b> <b>Minimum value</b> <b>Maximum value</b> <b>Conversion</b>	42 Control:Accel/Decel linkable destination x.x seconds 5.0 seconds 0.0 seconds 6553.5 seconds 10 = 1.0
43	<b>Accel Time 2</b> Enter the length of time for the drive to ramp from 0 rpm to the base speed. <i>Accel Time 2</i> is available only when the value of <i>L Option Mode</i> (parameter 116) is 4, 11, or 14.	<b>Parameter number</b> <b>File:group</b> <b>Parameter type</b> <b>Display</b> <b>Factory default</b> <b>Minimum value</b> <b>Maximum value</b> <b>Conversion</b>	43 Control:Accel/Decel linkable destination x.x seconds 10.0 seconds 0.0 seconds 6553.5 seconds 10 = 1.0
44	<b>Decel Time 1</b> Enter the length of time for the drive to ramp from base speed to 0 rpm. This is used for a ramp stop.	<b>Parameter number</b> <b>File:group</b> <b>Parameter type</b> <b>Display</b> <b>Factory default</b> <b>Minimum value</b> <b>Maximum value</b> <b>Conversion</b>	44 Control:Accel/Decel linkable destination x.x seconds 5.0 seconds 0.0 seconds 6553.5 seconds 10 = 1.0
45	<b>Decel Time 2</b> Enter the length of time for the drive to ramp from base speed to 0 rpm. This is used for a ramp stop. <i>Decel Time 2</i> is available only when the value of <i>L Option Mode</i> (parameter 116) is 4, 11, or 14.	<b>Parameter number</b> <b>File:group</b> <b>Parameter type</b> <b>Display</b> <b>Factory default</b> <b>Minimum value</b> <b>Maximum value</b> <b>Conversion</b>	45 Control:Accel/Decel linkable destination x.x seconds 10.0 seconds 0.0 seconds 6553.5 seconds 10 = 1.0

46	<b>Droop Percent</b>	Use <i>Droop Percent</i> to specify the percent of base speed that the speed reference is reduced when at full load torque. You can use this feature to cause motor speed to droop with an increase in load.	<table border="0"> <tr> <td><b>Parameter number</b></td> <td>46</td> </tr> <tr> <td><b>File:group</b></td> <td>Control:Speed Regulator</td> </tr> <tr> <td><b>Parameter type</b></td> <td>linkable destination</td> </tr> <tr> <td><b>Display</b></td> <td>x.x%</td> </tr> <tr> <td><b>Factory default</b></td> <td>0.0%</td> </tr> <tr> <td><b>Minimum value</b></td> <td>0.0%</td> </tr> <tr> <td><b>Maximum value</b></td> <td>25.5%</td> </tr> <tr> <td><b>Conversion</b></td> <td>10 = 1.0</td> </tr> </table>	<b>Parameter number</b>	46	<b>File:group</b>	Control:Speed Regulator	<b>Parameter type</b>	linkable destination	<b>Display</b>	x.x%	<b>Factory default</b>	0.0%	<b>Minimum value</b>	0.0%	<b>Maximum value</b>	25.5%	<b>Conversion</b>	10 = 1.0
<b>Parameter number</b>	46																		
<b>File:group</b>	Control:Speed Regulator																		
<b>Parameter type</b>	linkable destination																		
<b>Display</b>	x.x%																		
<b>Factory default</b>	0.0%																		
<b>Minimum value</b>	0.0%																		
<b>Maximum value</b>	25.5%																		
<b>Conversion</b>	10 = 1.0																		
47	<b>S-Curve Percent<sup>1</sup></b>	Use <i>S-Curve Percent</i> to create an adjustable S curve ramp. <i>S-Curve Percent</i> controls the level of filtering that is applied to the output of the acceleration and deceleration ramp.	<table border="0"> <tr> <td><b>Parameter number</b></td> <td>47</td> </tr> <tr> <td><b>File:group</b></td> <td>Control:Accel/Decel</td> </tr> <tr> <td><b>Parameter type</b></td> <td>linkable destination</td> </tr> <tr> <td><b>Display</b></td> <td>x.x%</td> </tr> <tr> <td><b>Factory default</b></td> <td>0.0%</td> </tr> <tr> <td><b>Minimum value</b></td> <td>0.0%</td> </tr> <tr> <td><b>Maximum value</b></td> <td>100.0%</td> </tr> <tr> <td><b>Conversion</b></td> <td>10 = 1.0%</td> </tr> </table> <p>Refer to the Speed Reference Selection Overview in Appendix B, <i>Control Block Diagrams</i>, for more information.</p>	<b>Parameter number</b>	47	<b>File:group</b>	Control:Accel/Decel	<b>Parameter type</b>	linkable destination	<b>Display</b>	x.x%	<b>Factory default</b>	0.0%	<b>Minimum value</b>	0.0%	<b>Maximum value</b>	100.0%	<b>Conversion</b>	10 = 1.0%
<b>Parameter number</b>	47																		
<b>File:group</b>	Control:Accel/Decel																		
<b>Parameter type</b>	linkable destination																		
<b>Display</b>	x.x%																		
<b>Factory default</b>	0.0%																		
<b>Minimum value</b>	0.0%																		
<b>Maximum value</b>	100.0%																		
<b>Conversion</b>	10 = 1.0%																		
<table border="1"> <thead> <tr> <th data-bbox="289 646 516 701">If S-Curve Percent is set to:</th> <th data-bbox="521 646 878 701">Then the S-Curve is:</th> </tr> </thead> <tbody> <tr> <td data-bbox="289 707 516 735">0</td> <td data-bbox="521 707 878 735">Not used.</td> </tr> <tr> <td data-bbox="289 741 516 768">50%</td> <td data-bbox="521 741 878 768">Applied for half of the ramp time.</td> </tr> <tr> <td data-bbox="289 774 516 800">100%</td> <td data-bbox="521 774 878 800">Applied for the entire ramp.</td> </tr> </tbody> </table>		If S-Curve Percent is set to:	Then the S-Curve is:	0	Not used.	50%	Applied for half of the ramp time.	100%	Applied for the entire ramp.	<p><sup>1</sup> <i>S-Curve Percent</i> was added in Version 2.xx.</p>									
If S-Curve Percent is set to:	Then the S-Curve is:																		
0	Not used.																		
50%	Applied for half of the ramp time.																		
100%	Applied for the entire ramp.																		
48	<b>PTrim Output</b>	<i>PTrim Output</i> represents the scaled and limited output of the process trim function. You can use <i>PTrim Output</i> as a parameter source or to offset the speed or torque reference. To offset the speed or torque reference, you need to select either bit 0 or bit 1 in <i>PTrim Select</i> (parameter 51).	<table border="0"> <tr> <td><b>Parameter number</b></td> <td>48</td> </tr> <tr> <td><b>File:group</b></td> <td>Application:Process Trim</td> </tr> <tr> <td><b>Parameter type</b></td> <td>source</td> </tr> <tr> <td><b>Display</b></td> <td>±x.x%</td> </tr> <tr> <td><b>Factory default</b></td> <td>not applicable</td> </tr> <tr> <td><b>Minimum value</b></td> <td>-800.0%</td> </tr> <tr> <td><b>Maximum value</b></td> <td>+800.0%</td> </tr> <tr> <td><b>Conversion</b></td> <td>4096 = 100.0%</td> </tr> </table> <p>Refer to the Trim Control Overview section in Appendix B, <i>Control Block Diagrams</i>, for more information.</p>	<b>Parameter number</b>	48	<b>File:group</b>	Application:Process Trim	<b>Parameter type</b>	source	<b>Display</b>	±x.x%	<b>Factory default</b>	not applicable	<b>Minimum value</b>	-800.0%	<b>Maximum value</b>	+800.0%	<b>Conversion</b>	4096 = 100.0%
<b>Parameter number</b>	48																		
<b>File:group</b>	Application:Process Trim																		
<b>Parameter type</b>	source																		
<b>Display</b>	±x.x%																		
<b>Factory default</b>	not applicable																		
<b>Minimum value</b>	-800.0%																		
<b>Maximum value</b>	+800.0%																		
<b>Conversion</b>	4096 = 100.0%																		
49	<b>PTrim Reference</b>	<i>PTrim Reference</i> is the reference input value for process trim. <i>PTrim Reference</i> and <i>PTrim Feedback</i> (parameter 50) are compared and used to update <i>PTrim Output</i> (parameter 48).	<table border="0"> <tr> <td><b>Parameter number</b></td> <td>49</td> </tr> <tr> <td><b>File:group</b></td> <td>Application:Process Trim</td> </tr> <tr> <td><b>Parameter type</b></td> <td>linkable destination</td> </tr> <tr> <td><b>Display</b></td> <td>±x.x%</td> </tr> <tr> <td><b>Factory default</b></td> <td>+0.0%</td> </tr> <tr> <td><b>Minimum value</b></td> <td>-800.0%</td> </tr> <tr> <td><b>Maximum value</b></td> <td>+800.0%</td> </tr> <tr> <td><b>Conversion</b></td> <td>4096 = 100.0%</td> </tr> </table> <p>Refer to the Trim Control Overview section in Appendix B, <i>Control Block Diagrams</i>, for more information.</p>	<b>Parameter number</b>	49	<b>File:group</b>	Application:Process Trim	<b>Parameter type</b>	linkable destination	<b>Display</b>	±x.x%	<b>Factory default</b>	+0.0%	<b>Minimum value</b>	-800.0%	<b>Maximum value</b>	+800.0%	<b>Conversion</b>	4096 = 100.0%
<b>Parameter number</b>	49																		
<b>File:group</b>	Application:Process Trim																		
<b>Parameter type</b>	linkable destination																		
<b>Display</b>	±x.x%																		
<b>Factory default</b>	+0.0%																		
<b>Minimum value</b>	-800.0%																		
<b>Maximum value</b>	+800.0%																		
<b>Conversion</b>	4096 = 100.0%																		
50	<b>PTrim Feedback</b>	<i>PTrim Feedback</i> is the feedback input value for process trim. <i>PTrim Feedback</i> and <i>PTrim Reference</i> (parameter 49) are compared and used to update <i>PTrim Output</i> (parameter 48).	<table border="0"> <tr> <td><b>Parameter number</b></td> <td>50</td> </tr> <tr> <td><b>File:group</b></td> <td>Application:Process Trim</td> </tr> <tr> <td><b>Parameter type</b></td> <td>linkable destination</td> </tr> <tr> <td><b>Display</b></td> <td>±x.x%</td> </tr> <tr> <td><b>Factory default</b></td> <td>+0.0%</td> </tr> <tr> <td><b>Minimum value</b></td> <td>-800.0%</td> </tr> <tr> <td><b>Maximum value</b></td> <td>+800.0%</td> </tr> <tr> <td><b>Conversion</b></td> <td>4096 = 100.0%</td> </tr> </table> <p>Refer to the Trim Control Overview section in Appendix B, <i>Control Block Diagrams</i>, for more information.</p>	<b>Parameter number</b>	50	<b>File:group</b>	Application:Process Trim	<b>Parameter type</b>	linkable destination	<b>Display</b>	±x.x%	<b>Factory default</b>	+0.0%	<b>Minimum value</b>	-800.0%	<b>Maximum value</b>	+800.0%	<b>Conversion</b>	4096 = 100.0%
<b>Parameter number</b>	50																		
<b>File:group</b>	Application:Process Trim																		
<b>Parameter type</b>	linkable destination																		
<b>Display</b>	±x.x%																		
<b>Factory default</b>	+0.0%																		
<b>Minimum value</b>	-800.0%																		
<b>Maximum value</b>	+800.0%																		
<b>Conversion</b>	4096 = 100.0%																		

**51 PTrim Select**

Use *PTrim Select* to select the options for the process trim regulator. If bits 0 and 1 are either both set or both clear, both the speed and the torque references remain unaffected. If bits 3 and 4 are both set, bit 3 takes priority.

The bits are defined as follows:

Bit	Description	Bit	Description	Bit	Description
0	<b>Speed Trim</b> Set to trim the speed reference.	3	<b>Set Output</b> Set the output option.	6	<b>Trim Enable</b> Enable process trim. OR'd with Process Trim bit 11 in <i>Logic Input Sts</i> (parameter 14).
1	<b>Torque Trim</b> Set to trim the torque reference.	4	<b>Preset Integ</b> Preset integrator option.	7	<b>Encoder Trim</b>
2	<b>Speed Input</b> Select the speed inputs.	5	<b>Trim Limiter</b> Force ON trim limit option.		

**Parameter number** 51  
**File:group** Application:Process Trim  
**Parameter type** linkable destination  
**Display** bits  
**Factory default** 00000000  
**Minimum value** 00000000  
**Maximum value** 11111111  
**Conversion** 1 = 1  
Refer to the Trim Control Overview section in Appendix B, *Control Block Diagrams*, for more information.

**52 PTrim Filter BW**

Use *PTrim Filter BW* to set the bandwidth of a single pole filter used with the error input for process trim. The input to the filter is the difference between *PTrim Reference* (parameter 49) and *PTrim Feedback* (parameter 50). The output of this filter is used as the input to the process trim regulator.

**Parameter number** 52  
**File:group** Application:Process Trim  
**Parameter type** linkable destination  
**Display** x.x radians/second  
**Factory default** 0.0 radians/second  
**Minimum value** 0.0 radians/second  
**Maximum value** 240.0 radians/second  
**Conversion** 10 = 1.0  
Refer to the Trim Control Overview section in Appendix B, *Control Block Diagrams*, for more information.

**53 PTrim Preload**

Use *PTrim Preload* to preset the output of the process trim regulator when you select either bit 3 (Set the output option) or bit 4 (Preset integrator option) in *PTrim Select* (parameter 51).

**Parameter number** 53  
**File:group** Application:Process Trim  
**Parameter type** linkable destination  
**Display** ±x.x%  
**Factory default** 0.0%  
**Minimum value** -800.0%  
**Maximum value** +800.0%  
**Conversion** 4096 = 100.0%  
Refer to the Trim Control Overview section in Appendix B, *Control Block Diagrams*, for more information.

**54 PTrim Ki**

Use *PTrim Ki* to control the integral gain of the process trim regulator. If Ki process trim is 1.0, the process trim PI regulator output equals 1 pu in 1 second for 1 pu process trim error.

**Parameter number** 54  
**File:group** Application:Process Trim  
**Parameter type** linkable destination  
**Display** x.xxx  
**Factory default** 1.000  
**Minimum value** 0.000  
**Maximum value** 16.000  
**Conversion** 4096 = 1.000  
Refer to the Trim Control Overview section in Appendix B, *Control Block Diagrams*, for more information.

55	<b>PTrim Kp</b>	Use <i>PTrim Kp</i> to control the proportional gain of the process trim regulator. If the Kp process trim is equal to 1.0, the process trim PI regulator output equals 1 pu for 1 pu process trim error.	<b>Parameter number</b> 55 <b>File:group</b> Application:Process Trim <b>Parameter type</b> linkable destination <b>Display</b> x.xxx <b>Factory default</b> 1.000 <b>Minimum value</b> 0.000 <b>Maximum value</b> 16.000 <b>Conversion</b> 4096 = 1.000 Refer to the Trim Control Overview section in Appendix B, <i>Control Block Diagrams</i> , for more information.
56	<b>Reserved</b>	Leave this parameter set to 0.	<b>Parameter number</b> 56 <b>File:group</b> <b>Parameter type</b> <b>Display</b> <b>Factory default</b> <b>Minimum value</b> <b>Maximum value</b> <b>Conversion</b>
57	<b>Reserved</b>	Leave this parameter set to 0.	<b>Parameter number</b> 57 <b>File:group</b> <b>Parameter type</b> <b>Display</b> <b>Factory default</b> <b>Minimum value</b> <b>Maximum value</b> <b>Conversion</b>
58	<b>PTrim Lo Limit</b>	Use <i>PTrim Lo Limit</i> to specify the low limit of the process trim regulator output value. The output of the process trim regulator is limited by adjustable high and low limits.	<b>Parameter number</b> 58 <b>File:group</b> Application:Process Trim <b>Parameter type</b> linkable destination <b>Display</b> ±x.x% <b>Factory default</b> -100.0% <b>Minimum value</b> -800.0% <b>Maximum value</b> +800.0% <b>Conversion</b> 4096 = 100.0% Refer to the Trim Control Overview section in Appendix B, <i>Control Block Diagrams</i> , for more information.
59	<b>PTrim Hi Limit</b>	Use <i>PTrim Hi Limit</i> to specify the high limit of the process trim regulator output value. The output of the process trim regulator is limited by adjustable high and low limits.	<b>Parameter number</b> 59 <b>File:group</b> Application:Process Trim <b>Parameter type</b> linkable destination <b>Display</b> ±x.x% <b>Factory default</b> +100.0% <b>Minimum value</b> -800.0% <b>Maximum value</b> +800.0% <b>Conversion</b> 4096 = 100.0% Refer to the Trim Control Overview section in Appendix B, <i>Control Block Diagrams</i> , for more information.

<b>60</b>	<b>PTrim Out Gain</b>	<p>The output of the process trim regulator is scaled by a gain factor. This occurs just before the upper and lower limit. Use <i>PTrim Out Gain</i> to specify the gain value to use. A negative gain value inverts the process trim output.</p>	<b>Parameter number</b>	60
			<b>File:group</b>	Application:Process Trim
			<b>Parameter type</b>	linkable destination
			<b>Display</b>	±x.xxx
			<b>Factory default</b>	+1.000
			<b>Minimum value</b>	-8.000
			<b>Maximum value</b>	+8.000
			<b>Conversion</b>	4096 = +1.000
			Refer to the Trim Control Overview section in Appendix B, <i>Control Block Diagrams</i> , for more information.	

<b>61</b>	<b>Max Rev Spd Trim</b>	<p>Use <i>Max Rev Spd Trim</i> to limit the minimum value of the speed reference after the process trim output and the external speed trim has been added.</p>	<b>Parameter number</b>	61
			<b>File:group</b>	Application:Process Trim
			<b>Parameter type</b>	linkable destination
			<b>Display</b>	±x.x rpm
			<b>Factory default</b>	- base motor speed rpm
			<b>Minimum value</b>	-6 x base motor speed rpm
			<b>Maximum value</b>	0.0 rpm
			<b>Conversion</b>	-4096 = base motor speed

<b>62</b>	<b>Max Fwd Spd Trim</b>	<p>Use <i>Max Fwd Spd Trim</i> to limit the maximum value of the speed reference after the process trim.</p>	<b>Parameter number</b>	62
			<b>File:group</b>	Application:Process Trim
			<b>Parameter type</b>	linkable destination
			<b>Display</b>	±x.x rpm
			<b>Factory default</b>	+ base motor speed rpm
			<b>Minimum value</b>	0.0 rpm
			<b>Maximum value</b>	+6 x base motor speed rpm
			<b>Conversion</b>	4096 = base motor speed

<b>63</b>	<b>Scaled Spd Fdbk</b>	<p><i>Scaled Spd Fdbk</i> is a scaled version of speed feedback. The inverse of either <i>Speed Scale 1</i> (parameter 30) or <i>Speed Scale 7</i> (parameter 37) is used.</p>	<b>Parameter number</b>	63
			<b>File:group</b>	Control:Speed Feedback
			<b>Parameter type</b>	source
			<b>Display</b>	±x
			<b>Factory default</b>	not applicable
			<b>Minimum value</b>	-32767
			<b>Maximum value</b>	+32767
			<b>Conversion</b>	1 = 1

<b>64</b>	<b>Fdbk Device Type</b>	<p>Use <i>Fdbk Device Type</i> to choose the source for motor speed feedback from the following options:</p> <table border="1"> <thead> <tr> <th>Value</th> <th>Description</th> </tr> </thead> <tbody> <tr> <td>1</td> <td><b>Encoderless</b> Use this mode if you do not have an encoder.</td> </tr> <tr> <td>2</td> <td><b>Encoder</b> Use this mode if you do have an encoder.</td> </tr> <tr> <td>3</td> <td><b>Simulator</b> Use this mode to simulate a motor.</td> </tr> <tr> <td>4</td> <td><b>Encoderless W/Deadband</b> Use this mode if you do not have an encoder and operation below 1Hz is not required.</td> </tr> </tbody> </table> <p>Whenever possible, you should use the start up procedure to change the feedback device type because the start up procedure automatically re-adjusts the speed loop gains when you change between encoder and encoderless operation.</p>	Value	Description	1	<b>Encoderless</b> Use this mode if you do not have an encoder.	2	<b>Encoder</b> Use this mode if you do have an encoder.	3	<b>Simulator</b> Use this mode to simulate a motor.	4	<b>Encoderless W/Deadband</b> Use this mode if you do not have an encoder and operation below 1Hz is not required.	<b>Parameter number</b>	64
			Value	Description										
1	<b>Encoderless</b> Use this mode if you do not have an encoder.													
2	<b>Encoder</b> Use this mode if you do have an encoder.													
3	<b>Simulator</b> Use this mode to simulate a motor.													
4	<b>Encoderless W/Deadband</b> Use this mode if you do not have an encoder and operation below 1Hz is not required.													
			<b>File:group</b>	Control:Feedback Device										
			<b>Parameter type</b>	destination										
			<b>Display</b>	x										
			<b>Factory default</b>	1										
			<b>Minimum value</b>	1										
			<b>Maximum value</b>	3										
			<b>Conversion</b>	1 = 1										
			Refer to Chapter 9, <i>Applications</i> , for information about the advantages and disadvantages of encoderless and encoder modes.											

<b>65</b>	<b>Fdbk Filter Sel</b>	<p>Use <i>Fdbk Filter Sel</i> to select the type of feedback filter. You can choose among the following filters:</p> <table border="1"> <thead> <tr> <th>Value</th> <th>Description</th> </tr> </thead> <tbody> <tr> <td>0</td> <td><b>No Filter</b> Use this option if you do not want to filter the feedback.</td> </tr> <tr> <td>1</td> <td><b>35/49 rad</b> Use a "light" 35/49 radian feedback filter.</td> </tr> <tr> <td>2</td> <td><b>20/40 rad</b> Use a "heavy" 20/40 radian feedback filter.</td> </tr> <tr> <td>3</td> <td><b>Lead/Lag</b> Use a single pole lead lag feedback filter. You need to set up <i>Fdbk Filter Gain</i> (par. 66) and <i>Fdbk Filter BW</i> (par. 67).</td> </tr> <tr> <td>4</td> <td><b>Notch</b> Use a notch filter. You need to set up <i>Notch Filtr Freq</i> (par. 185) and <i>Notch Filtr Q</i> (par. 186).</td> </tr> </tbody> </table>	Value	Description	0	<b>No Filter</b> Use this option if you do not want to filter the feedback.	1	<b>35/49 rad</b> Use a "light" 35/49 radian feedback filter.	2	<b>20/40 rad</b> Use a "heavy" 20/40 radian feedback filter.	3	<b>Lead/Lag</b> Use a single pole lead lag feedback filter. You need to set up <i>Fdbk Filter Gain</i> (par. 66) and <i>Fdbk Filter BW</i> (par. 67).	4	<b>Notch</b> Use a notch filter. You need to set up <i>Notch Filtr Freq</i> (par. 185) and <i>Notch Filtr Q</i> (par. 186).	<p><b>Parameter number</b> 65</p> <p><b>File:group</b> Control:Speed Feedback</p> <p><b>Parameter type</b> linkable destination</p> <p><b>Display</b> x</p> <p><b>Factory default</b> 0</p> <p><b>Minimum value</b> 0</p> <p><b>Maximum value</b> 4</p> <p><b>Conversion</b> 1 = 1</p> <p>Refer to Appendix B, <i>Control Block Diagrams</i>, for information about <i>Fdbk Filter Sel</i>.</p>
			Value	Description											
0	<b>No Filter</b> Use this option if you do not want to filter the feedback.														
1	<b>35/49 rad</b> Use a "light" 35/49 radian feedback filter.														
2	<b>20/40 rad</b> Use a "heavy" 20/40 radian feedback filter.														
3	<b>Lead/Lag</b> Use a single pole lead lag feedback filter. You need to set up <i>Fdbk Filter Gain</i> (par. 66) and <i>Fdbk Filter BW</i> (par. 67).														
4	<b>Notch</b> Use a notch filter. You need to set up <i>Notch Filtr Freq</i> (par. 185) and <i>Notch Filtr Q</i> (par. 186).														

<b>66</b>	<b>Fdbk Filter Gain</b>	<p>Use <i>Fdbk Filter Gain</i> to specify the Kn term of the single pole lead/lag feedback filter.</p> <table border="1"> <thead> <tr> <th>If KN is:</th> <th>Then:</th> </tr> </thead> <tbody> <tr> <td>Greater than 1.0</td> <td>A lead filter is produced.</td> </tr> <tr> <td>Less than 1.0</td> <td>A lag filter is produced.</td> </tr> <tr> <td>Equal to 1.0</td> <td>The feedback filter is disabled.</td> </tr> <tr> <td>Equal to 0.0</td> <td>A simple, low pass filter is produced.</td> </tr> </tbody> </table> <p>You need to set this parameter if <i>Fdbk Filter Sel</i> (parameter 65) is set to 3.</p>	If KN is:	Then:	Greater than 1.0	A lead filter is produced.	Less than 1.0	A lag filter is produced.	Equal to 1.0	The feedback filter is disabled.	Equal to 0.0	A simple, low pass filter is produced.	<p><b>Parameter number</b> 66</p> <p><b>File:group</b> Control:Speed Feedback</p> <p><b>Parameter type</b> linkable destination</p> <p><b>Display</b> ±x.xx</p> <p><b>Factory default</b> +1.00</p> <p><b>Minimum value</b> -5.00</p> <p><b>Maximum value</b> +5.00</p> <p><b>Conversion</b> 256 = 1.00</p>
			If KN is:	Then:									
Greater than 1.0	A lead filter is produced.												
Less than 1.0	A lag filter is produced.												
Equal to 1.0	The feedback filter is disabled.												
Equal to 0.0	A simple, low pass filter is produced.												

<b>67</b>	<b>Fdbk Filter BW</b>	<p>Use <i>Fdbk Filter BW</i> to establish the breakpoint frequency (in radians) for the speed feedback lead/lag filter. You need to set this parameter if <i>Fdbk Filter Sel</i> (parameter 65) is set to 3.</p>	<p><b>Parameter number</b> 67</p> <p><b>File:group</b> Control:Speed Feedback</p> <p><b>Parameter type</b> linkable destination</p> <p><b>Display</b> x.x radians/second</p> <p><b>Factory default</b> 100.0 radians/second</p> <p><b>Minimum value</b> 0.2 radian/second</p> <p><b>Maximum value</b> 900.0 radians/second</p> <p><b>Conversion</b> 10 = 1.0</p>
-----------	-----------------------	--	--

<b>68</b>	<b>Spd/Trq Mode Sel</b>	Use <i>Spd/Trq Mode Sel</i> to select the source for the drive torque reference. <i>Spd/Trq Mode Sel</i> operates as a selector switch. The position of the selector determines the torque reference selection as follows:	<b>Parameter number</b>	68
			<b>File:group</b>	Control:Speed/Torq Mode
			<b>Parameter type</b>	linkable destination
			<b>Display</b>	bits
			<b>Factory default</b>	1
			<b>Minimum value</b>	0
			<b>Maximum value</b>	5
			<b>Conversion</b>	1 = 1
			For a more detailed description of these bits, refer to the Torque Reference Overview section in Appendix B, <i>Control Block Diagrams</i> .	
<b>Value</b>	<b>Description</b>	<b>Value</b>	<b>Description</b>	<b>Value</b>
0	<b>Zero Torque</b> Zero Torque	3	<b>Min Trq/Spd</b> Selects the smallest value when the torque reference and the torque generated from the speed are compared.	5
1	<b>Speed Reg</b> Speed Regulate			<b>Sum Trq/Spd</b> Selects the sum of the torque reference and the torque generated from the speed.
2	<b>Torque Reg</b> External Torque	4	<b>Max Trq/Spd</b> Selects the largest value when the torque reference and the torque generated from the speed are compared.	
<b>69</b>	<b>Torque Ref 1</b>		<b>Parameter number</b>	69
	Use <i>Torque Ref 1</i> to supply an external motor torque reference to the drive. To select the external torque reference, set <i>Spd/Trq Mode Sel</i> (parameter 68) to a value of 2.		<b>File:group</b>	Control:Torque Reference
			<b>Parameter type</b>	linkable destination
			<b>Display</b>	±x.x%
			<b>Factory default</b>	+0.0%
			<b>Minimum value</b>	-800.0%
			<b>Maximum value</b>	+800.0%
			<b>Conversion</b>	4096 = 100.0%
<b>70</b>	<b>Slave Torque %</b>		<b>Parameter number</b>	70
	Use <i>Slave Torque %</i> to specify the gain value that is multiplied to <i>Torque Ref 1</i> (parameter 69).		<b>File:group</b>	Control:Torque Reference
			<b>Parameter type</b>	linkable destination
			<b>Display</b>	±x.xx%
			<b>Factory default</b>	+100.00%
			<b>Minimum value</b>	-200.00%
			<b>Maximum value</b>	+200.00%
			<b>Conversion</b>	4096 = 1.00%
<b>71</b>	<b>Min Flux Level</b>		<b>Parameter number</b>	71
	Use <i>Min Flux Level</i> to set the smallest level of flux used to convert a torque to a current reference above base speed. Setting <i>Min Flux Level</i> to a value less than 100%, such as 25%, will increase the speed regulator gains to compensate for the loss of gain/bandwidth that occurs above base speed due to field weakening. Reducing <i>Min Flux Level</i> below 100% may result in unstable operation above base speed when in encoderless mode.		<b>File:group</b>	none
			<b>Parameter type</b>	linkable destination
			<b>Display</b>	x.x%
			<b>Factory default</b>	100.0%
			<b>Minimum value</b>	12.5%
			<b>Maximum value</b>	100.0%
			<b>Conversion</b>	4096 = 100.0%



<p><b>72</b></p> <p><b>Pos Mtr Cur Lim</b></p> <p>Enter the largest allowable positive motor stator current up to 200% or 400% as determined by <i>Max Mtr Current</i> (parameter 195). Values over 150% of the inverter rated current (or 135% for the 460V/800HP H frame) may not be attainable. Bit 0 in <i>Torque Limit Sts</i> (parameter 87) indicates when <i>Pos Mtr Cur Lim</i> is actively restricting current.</p> <p>Changing <i>Pos Mtr Cur Lim</i> affects <i>Pos Torque Lim</i> (parameter 74). If you lower <i>Pos Mtr Cur Lim</i>, you may also lower the range of <i>Pos Torque Lim</i>. If you then raise <i>Pos Mtr Cur Lim</i>, <i>Pos Torque Lim</i> may remain at the lower value due to the range change.</p> <p>You cannot change this value while the drive is running.</p>		<p><b>Parameter number</b> 72</p> <p><b>File:group</b> Control:Control Limits</p> <p><b>Parameter type</b> destination</p> <p><b>Display</b> x.x%</p> <p><b>Factory default</b> 200.0%</p> <p><b>Minimum value</b> 0.0%</p> <p><b>Maximum value</b> calculated</p> <p><b>Conversion</b> 4096 = 100.0%</p>
<p><b>73</b></p> <p><b>Neg Mtr Cur Lim</b></p> <p>Enter the largest allowable negative motor stator current up to 200% or 400% as determined by <i>Max Mtr Current</i> (parameter 195). Values over 150% of the inverter rated current (or 135% for the 460V/800HP H frame) may not be attainable. Bit 0 in <i>Torque Limit Sts</i> (parameter 87) indicates when <i>Neg Mtr Cur Lim</i> is actively restricting current.</p> <p>Changing <i>Neg Mtr Cur Lim</i> affects <i>Neg Torque Lim</i> (parameter 75). If you lower <i>Neg Mtr Cur Lim</i>, you may also lower the range of <i>Neg Torque Lim</i>. If you later raise <i>Neg Mtr Cur Lim</i>, <i>Neg Torque Lim</i> may remain at the lower value due to the range change.</p> <p>You cannot change this value while the drive is running.</p>		<p><b>Parameter number</b> 73</p> <p><b>File:group</b> Control:Control Limits</p> <p><b>Parameter type</b> destination</p> <p><b>Display</b> -x.x%</p> <p><b>Factory default</b> -200.0%</p> <p><b>Minimum value</b> calculated</p> <p><b>Maximum value</b> 0.0%</p> <p><b>Conversion</b> -4096 = -100.0%</p>
<p><b>74</b></p> <p><b>Pos Torque Lim</b></p> <p>Enter the torque limit for positive torque reference values. The positive motor torque reference will not be allowed to exceed this value. <i>Pos Mtr Cur Lim</i> (parameter 72) affects the maximum value of <i>Pos Torque Lim</i>.</p>		<p><b>Parameter number</b> 74</p> <p><b>File:group</b> Control:Control Limits</p> <p><b>Parameter type</b> linkable destination</p> <p><b>Display</b> x.x%</p> <p><b>Factory default</b> 200.0%</p> <p><b>Minimum value</b> 0.0%</p> <p><b>Maximum value</b> calculated</p> <p><b>Conversion</b> 4096 = 100.0%</p>
<p><b>75</b></p> <p><b>Neg Torque Lim</b></p> <p>Enter the the torque limit for the negative torque reference values. The negative motor torque reference will not be allowed to exceed this value. <i>Neg Mtr Cur Lim</i> (parameter 73) affects the minimum value of <i>Neg Torque Lim</i>.</p>		<p><b>Parameter number</b> 75</p> <p><b>File:group</b> Control:Control Limits</p> <p><b>Parameter type</b> linkable destination</p> <p><b>Display</b> -x.x%</p> <p><b>Factory default</b> -200.0%</p> <p><b>Minimum value</b> calculated</p> <p><b>Maximum value</b> 0.0%</p> <p><b>Conversion</b> -4096 = -100.0%</p>
<p><b>76</b></p> <p><b>Regen Power Lim</b></p> <p>Enter the maximum power level that is transferred from the motor to the DC bus. If you are using an external dynamic brake, you should set <i>Regen Power Limit</i> to the default level of the drive.</p>		<p><b>Parameter number</b> 76</p> <p><b>File:group</b> Control:Control Limits</p> <p><b>Parameter type</b> linkable destination</p> <p><b>Display</b> -x.x%</p> <p><b>Factory default</b> -200.0%</p> <p><b>Minimum value</b> -800.0%</p> <p><b>Maximum value</b> 0.0%</p> <p><b>Conversion</b> -4096 = -100.0%</p>

77	<b>Current Rate Lim</b>	Enter the largest allowable rate of change for the current reference signal. This number is scaled in units of maximum per unit current every two milliseconds.	<b>Parameter number</b> 77 <b>File:group</b> Control:Control Limits <b>Parameter type</b> linkable destination <b>Display</b> x.x% <b>Factory default</b> 20.0% <b>Minimum value</b> calculated <b>Maximum value</b> 200.0% <b>Conversion</b> 4096 = 100.0%
78	<b>Fast Flux Level</b>	Enter the percent of rated motor current to be used to flux up the motor fast. The larger the value, the faster the motor reaches rated flux. To enable the fast flux up feature, you must set bit 8 in <i>Bus/Brake Option</i> (parameter 13).	<b>Parameter number</b> 78 <b>File:group</b> Application:Fast Flux Up <b>Parameter type</b> destination <b>Display</b> x.x% <b>Factory default</b> 200.0% <b>Minimum value</b> 100.0% <b>Maximum value</b> calculated <b>Conversion</b> 4096 = 100.0% Refer to the Enabling Fast Flux Up section of Chapter 12, <i>Troubleshooting</i> , for more information.
79	<b>DC Brake Current<sup>1</sup></b>	Enter the percent of motor current to be used for DC braking the motor. To enable DC braking, you need to set bit 9 in <i>Bus/Brake Opts</i> (parameter 13).	<b>Parameter number</b> 79 <b>File:group</b> Application:DC Braking/Hold <b>Parameter type</b> linkable destination <b>Display</b> x.x% <b>Factory default</b> 50.0% <b>Minimum value</b> 0.0% <b>Maximum value</b> calculated <b>Conversion</b> 4096 = 100.0% current Refer to Chapter 9, <i>Applications</i> , for more information.
80	<b>DC Brake Time<sup>1</sup></b>	Enter the period of time that the DC braking current should be applied after a stop has been commanded. To enable DC braking, you need to set bit 9 in <i>Bus/Brake Opts</i> (parameter 13).	<b>Parameter number</b> 80 <b>File:group</b> Application:DC Braking/Hold <b>Parameter type</b> destination <b>Display</b> x.x seconds <b>Factory default</b> 10.0 seconds <b>Minimum value</b> 0.0 seconds <b>Maximum value</b> 6553.5 seconds <b>Conversion</b> 10=1.0 seconds Refer to Chapter 9, <i>Applications</i> , for more information.
81	<b>Motor Speed</b>	<i>Motor Speed</i> contains a filtered version of speed feedback. The value displayed in <i>Motor Speed</i> is passed through a low pass filter having a 125 millisecond time constant.	<b>Parameter number</b> 81 <b>File:group</b> Monitor:Motor Status <b>Parameter type</b> source <b>Display</b> ±x.x rpm <b>Factory default</b> not applicable <b>Minimum value</b> -8 x base motor speed <b>Maximum value</b> +8 x base motor speed <b>Conversion</b> 4096 = base motor speed
82	<b>Command Spd Sts</b>	<i>Command Spd Sts</i> is the high word portion of a 32-bit speed reference quantity. It is the input term for the Speed PI Regulator.	<b>Parameter number</b> 82 <b>File:group</b> Monitor:Drive/Inv Status <b>Parameter type</b> source <b>Display</b> ±x.x rpm <b>Factory default</b> not applicable <b>Minimum value</b> -8 x base motor speed <b>Maximum value</b> +8 x base motor speed <b>Conversion</b> 4096 = base motor speed

<b>83</b>	<b>Motor Current</b>	Use <i>Motor Current</i> to view the actual RMS value of the motor current as determined from the LEM current sensors. This data is averaged and updated every 50 milliseconds.	<b>Parameter number</b> 83 <b>File:group</b> Monitor:Motor Status <b>Parameter type</b> source <b>Display</b> x.x amp <b>Factory default</b> not applicable <b>Minimum value</b> 0.0 amps <b>Maximum value</b> 6553.5 amps <b>Conversion</b> 4096 = rated inverter amps
<b>84</b>	<b>DC Bus Voltage</b>	DC <i>Bus Voltage</i> represents the actual bus voltage in volts as read by the software from an analog input port.	<b>Parameter number</b> 84 <b>File:group</b> Monitor:Drive/Inv Status <b>Parameter type</b> source <b>Display</b> x volts <b>Factory default</b> not applicable <b>Minimum value</b> 0 volts <b>Maximum value</b> 1000 volts <b>Conversion</b> 1 = 1
<b>85</b>	<b>Motor Voltage</b>	Use <i>Motor Voltage</i> to view the actual line-to-line fundamental RMS value of motor voltage. This data is averaged and updated every 50 milliseconds.	<b>Parameter number</b> 85 <b>File:group</b> Monitor:Motor Status <b>Parameter type</b> source <b>Display</b> x volt <b>Factory default</b> not applicable <b>Minimum value</b> 0 volts <b>Maximum value</b> +3000 volts <b>Conversion</b> 1 = 1
<b>86</b>	<b>Motor Torque %</b>	Use <i>Motor Torque %</i> to view the calculated value of motor torque as determined by the drive. The actual value of the motor torque is within 5% of this value. This data is updated every 2 milliseconds.	<b>Parameter number</b> 86 <b>File:group</b> Monitor:Motor Status <b>Parameter type</b> source <b>Display</b> ±x.x% trq <b>Factory default</b> not applicable <b>Minimum value</b> -800.0% <b>Maximum value</b> +800.0% <b>Conversion</b> 4096 = 100.0%

<b>87</b>	<b>Torque Limit Sts</b>	Use <i>Torque Limit Sts</i> to view a bit-coded summary of any condition that may be limiting either the current or the torque reference.	<b>Parameter number</b>	87
			<b>File:group</b>	Monitor:Drive/Inv Status
			<b>Parameter type</b>	source
			<b>Display</b>	bits
			<b>Factory default</b>	not applicable
			<b>Minimum value</b>	00000000.00000000
			<b>Maximum value</b>	01111111.11111111
			<b>Conversion</b>	1 = 1
			Refer to Appendix B, <i>Control Block Diagrams</i> , for more information on the NTC and IT inverter foldbacks.	

The bits are defined as follows:

Value	Description	Value	Description	Value	Description
0	<b>+Mtr Iq Lim</b> Positive motor current limit	6	<b>+Atune Trq</b> Positive auto-tune torque	12	<b>-Torque Lim</b> Negative torque limit
1	<b>+NTC Foldbak</b> Positive NTC inverter foldback	7	<b>Reserved</b> Leave 0.	13	<b>-Trq Pwr Lim</b> Negative torque power limit
2	<b>+IT Foldback</b> Positive IT inverter foldback	8	<b>-Mtr Iq Lim</b> Negative motor current limit	14	<b>-Atune Trq</b> Negative auto-tune torque limit
3	<b>+Flux Brake</b> Iq limited due to flux braking.	9	<b>-NTC Foldbak</b> Negative NTC inverter protection foldback	15	<b>Reserved</b> Leave 0.
4	<b>+Torque Lim</b> Positive torque limit	10	<b>-IT Foldback</b> IT inverter protection foldback		
5	<b>+Trq Pwr Lim</b> Positive torque power limit	11	<b>-Flux Brake</b> Iq limited due to flux braking.		

<b>88</b>	<b>Motor Flux %</b>	Use <i>Motor Flux %</i> to view the level of motor field flux calculated by the drive.	<b>Parameter number</b>	88
			<b>File:group</b>	Monitor:Motor Status
			<b>Parameter type</b>	source
			<b>Display</b>	x.x%
			<b>Factory default</b>	not applicable
			<b>Minimum value</b>	12.5%
			<b>Maximum value</b>	100.0%
			<b>Conversion</b>	4096 = 100.0%

<b>89</b>	<b>Motor Frequency</b>	Use <i>Motor Frequency</i> to view the actual value of motor stator frequency in Hz.	<b>Parameter number</b>	89
			<b>File:group</b>	Monitor:Motor Status
			<b>Parameter type</b>	source
			<b>Display</b>	x.xxx Hz
			<b>Factory default</b>	not applicable
			<b>Minimum value</b>	-250.000 Hz
			<b>Maximum value</b>	+250.000 Hz
			<b>Conversion</b>	128 = 1.000

<b>90</b>	<b>Motor Power %</b>	<i>Motor Power %</i> is the calculated product of torque reference times motor speed feedback. A 125 millisecond filter is applied to this result. Positive values indicate motoring power; negative values indicate regenerative power.	<b>Parameter number</b>	90
			<b>File:group</b>	Monitor:Motor Status
			<b>Parameter type</b>	source
			<b>Display</b>	±x.x% PWR
			<b>Factory default</b>	not applicable
			<b>Minimum value</b>	-800.0%
			<b>Maximum value</b>	+800.0%
			<b>Conversion</b>	4096 = 100.0%

<b>91</b>	<b>Iq %</b> <i>Iq %</i> shows the value of torque current reference that is present at the output of the current rate limiter. 100% is equal to 1 per unit (pu) rated motor torque.	<b>Parameter number</b>	91
		<b>File:group</b>	none
		<b>Parameter type</b>	source
		<b>Display</b>	±x.x%
		<b>Factory default</b>	not applicable
		<b>Minimum value</b>	-800.0%
		<b>Maximum value</b>	+800.0%
		<b>Conversion</b>	4096 = 100.0%

<b>92</b>	<b>Test Data 1</b> Use <i>Test Data 1</i> to view a data value that corresponds to the value selected in <i>Test Select 1</i> (parameter 93). <i>Test Data 1</i> is a diagnostic tool used to view internal drive parameters.	<b>Parameter number</b>	92
		<b>File:group</b>	Monitor:Testpoints Fault Setup:Testpoints
		<b>Parameter type</b>	source
		<b>Display</b>	±x
		<b>Factory default</b>	not applicable
		<b>Minimum value</b>	-32768
		<b>Maximum value</b>	+32767
		<b>Conversion</b>	1 = 1

<b>93</b>	<b>Test Select 1</b> <i>Test Select 1</i> is a diagnostic tool that you can use to access specific test points. The value you enter specifies which data value should be displayed in <i>Test Data 1</i> (parameter 92).	<b>Parameter number</b>	93
		<b>File:group</b>	Monitor:Testpoints Fault Setup:Testpoints
		<b>Parameter type</b>	linkable destination
		<b>Display</b>	x
		<b>Factory default</b>	0
		<b>Minimum value</b>	0
		<b>Maximum value</b>	65535
		<b>Conversion</b>	1 = 1

If you enter this value for *Test Select 1* (parameter 93):

Then, the value in *Test Data 1* (parameter 92) represents the:

12

Precharge status

86

Approximate fluxing time

<b>94</b>	<b>Test Data 2</b> Use <i>Test Data 2</i> to view a data value that corresponds to the value selected in <i>Test Select 2</i> (parameter 95). <i>Test Data 2</i> is a diagnostic tool used to view internal parameters.	<b>Parameter number</b>	94
		<b>File:group</b>	Monitor:Testpoints Fault Setup:Testpoints
		<b>Parameter type</b>	source
		<b>Display</b>	±x
		<b>Factory default</b>	not applicable
		<b>Minimum value</b>	-32768
		<b>Maximum value</b>	+32767
		<b>Conversion</b>	1 = 1

<b>95</b>	<b>Test Select 2</b>	<b>Parameter number</b>	95
		<b>File:group</b>	Monitor:Testpoints Fault Setup:Testpoints linkable destination
	<p><i>Test Select 2</i> is a diagnostic tool that you can use to access specific testpoints. The value you enter specifies which data values should be displayed in <i>Test Data 2</i> (parameter 94). For <i>Test Select 2</i> values of 11100 through 11232, you need to first enter a 111xx value to determine the number of hours since power up, and then enter a 112xx value to determine the number of minutes and seconds since power up.</p>	<b>Parameter type</b>	
		<b>Display</b>	x
		<b>Factory default</b>	0
		<b>Minimum value</b>	0
		<b>Maximum value</b>	65535
		<b>Conversion</b>	1 = 1

If you enter this value for <i>Test Select 2</i> (parameter 95):	Then, the value in <i>Test Data 2</i> (parameter 94) represents the:
9728	Scaled version of <i>Torque Ref 1</i> (parameter 69)
9730	Sum of scaled <i>Torque Ref 1</i> (parameter 69) and <i>PTrim Output</i> (parameter 48)
9987	Upper current limit (4096 @ rated motor positive current)
9988	Lower current limit (-4096 @ rated motor negative current)
9990	Upper torque limit (4096 @ rated motor positive torque)
9991	Lower torque limit (-4096 @ rated motor negative torque)
10000	<i>Motor Flux %</i> (parameter 88) limited to <i>Min Flux Level</i> (parameter 71)
10264	Value of <i>Logic Input Status</i> (par 14) at the time of the last stop event.
10503	Parameter limit conditions
10504	Parameter limit conditions
10505	Speed reference math limits
10506	Speed feedback math limits
10507	Speed regulator math limits
10508	Torque reference math limits
10509	Process trim math limits
	<b>hours    minutes/seconds</b>
11100	11200 Realtime accumulated since power up
11101	11201 The time since power up that the fault in position 1 occurred
11102	11202 The time since power up that the fault in position 2 occurred
11103	11203 The time since power up that the fault in position 3 occurred
11104	11204 The time since power up that the fault in position 4 occurred
11105	11205 The time since power up that the fault in position 5 occurred
11106	11206 The time since power up that the fault in position 6 occurred
11107	11207 The time since power up that the fault in position 7 occurred
11108	11208 The time since power up that the fault in position 8 occurred
11109	11209 The time since power up that the fault in position 9 occurred
11110	11210 The time since power up that the fault in position 10 occurred
11111	11211 The time since power up that the fault in position 11 occurred
11112	11212 The time since power up that the fault in position 12 occurred
11113	11213 The time since power up that the fault in position 13 occurred
11114	11214 The time since power up that the fault in position 14 occurred
11115	11215 The time since power up that the fault in position 15 occurred
11116	11216 The time since power up that the fault in position 16 occurred
11117	11217 The time since power up that the fault in position 17 occurred
11118	11218 The time since power up that the fault in position 18 occurred
11119	11219 The time since power up that the fault in position 19 occurred
11120	11220 The time since power up that the fault in position 20 occurred
11121	11221 The time since power up that the fault in position 21 occurred
11122	11222 The time since power up that the fault in position 22 occurred
11123	11223 The time since power up that the fault in position 23 occurred

If you enter this value for <i>Test Select 2</i> (parameter 95):		Then, the value in <i>Test Data 2</i> (parameter 94) represents the:
hours	minutes/seconds	
11124	11224	The time since power up that the fault in position 24 occurred
11125	11225	The time since power up that the fault in position 25 occurred
11126	11226	The time since power up that the fault in position 26 occurred
11127	11227	The time since power up that the fault in position 27 occurred
11128	11228	The time since power up that the fault in position 28 occurred
11129	11229	The time since power up that the fault in position 29 occurred
11130	11230	The time since power up that the fault in position 30 occurred
11131	11231	The time since power up that the fault in position 31 occurred
11132	11232	The time since power up that the fault in position 32 occurred
58144		Drive software version (example: 101)
58146		Drive power structure type
58220		Speed regulator output
58228		Speed error (reference — feedback)
58230		Unfiltered speed feedback (4096 @ Nameplate RPM)
58250		Internal torque reference (4096 @ rated motor torque)
58296		Inverter temperature feedback (degrees Celsius)

<b>96</b>	<b>An In 1 Value</b> Use <i>An In 1 Value</i> to view the converted analog value of the input at analog input 1.	<b>Parameter number</b>	96
		<b>File:group</b>	Interface/Comm:Analog Inputs
		<b>Parameter type</b>	source
		<b>Display</b>	±x
		<b>Factory default</b>	not applicable
		<b>Minimum value</b>	-32767
		<b>Maximum value</b>	+32767
		<b>Conversion</b>	1 = 1
<b>97</b>	<b>An In 1 Offset</b> Use <i>An In 1 Offset</i> to set the offset applied to the raw analog value of the analog input 1 before the scale factor is applied. This lets you shift the range of the analog input.	<b>Parameter number</b>	97
		<b>File:group</b>	Interface/Comm:Analog Inputs
		<b>Parameter type</b>	linkable destination
		<b>Display</b>	±x.xxx volts
		<b>Factory default</b>	0.000 volts
		<b>Minimum value</b>	-19.980 volts
		<b>Maximum value</b>	+19.980 volts
		<b>Conversion</b>	205 = 1.000
<b>98</b>	<b>An In 1 Scale</b> Use <i>An In 1 Scale</i> to set the scale factor or gain for analog input 1. The value of analog input 1 is converted to +2048 and then the scale is applied. This provides an effective digital range of ±32767.	<b>Parameter number</b>	98
		<b>File:group</b>	Interface/Comm:Analog Inputs
		<b>Parameter type</b>	linkable destination
		<b>Display</b>	±x.xxx
		<b>Factory default</b>	+2.000
		<b>Minimum value</b>	-16.000
		<b>Maximum value</b>	+16.000
		<b>Conversion</b>	2048 = 1.000
<b>99</b>	<b>An In 2 Value</b> Use <i>An In 2 Value</i> to view the converted analog value of the input at analog input 2.	<b>Parameter number</b>	99
		<b>File:group</b>	Interface/Comm:Analog Inputs
		<b>Parameter type</b>	source
		<b>Display</b>	±x
		<b>Factory default</b>	not applicable
		<b>Minimum value</b>	-32767
		<b>Maximum value</b>	+32767
		<b>Conversion</b>	1 = 1

<b>100</b>	<b>An In 2 Offset</b> Use <i>An In 2 Offset</i> to set the offset applied to the raw analog value of analog input 2 before the scale factor is applied. This lets you shift the range of the analog input.	<b>Parameter number</b>	100
		<b>File:group</b>	Interface/Comm:Analog Inputs
		<b>Parameter type</b>	linkable destination
		<b>Display</b>	±x.xxx volts
		<b>Factory default</b>	0.000 volts
		<b>Minimum value</b>	-19.980 volts
		<b>Maximum value</b>	+19.980 volts
		<b>Conversion</b>	205 = 1.000
<b>101</b>	<b>An In 2 Scale</b> Use <i>An In 2 Scale</i> to set the scale factor or gain for analog input 2. The value of analog input 2 is converted to +2048 and then the scale is applied. This provides an effective digital range of ±32767.	<b>Parameter number</b>	101
		<b>File:group</b>	Interface/Comm:Analog Inputs
		<b>Parameter type</b>	linkable destination
		<b>Display</b>	±x.xxx
		<b>Factory default</b>	+2.000
		<b>Minimum value</b>	-16.000
		<b>Maximum value</b>	+16.000
		<b>Conversion</b>	2048 = 1.000
<b>102</b>	<b>mA Input Value</b> Use <i>mA Input Value</i> to view the converted analog value of the milli amp input.	<b>Parameter number</b>	102
		<b>File:group</b>	Interface/Comm:Analog Inputs
		<b>Parameter type</b>	source
		<b>Display</b>	±x
		<b>Factory default</b>	not applicable
		<b>Minimum value</b>	-32767
		<b>Maximum value</b>	+32767
		<b>Conversion</b>	1 = 1
<b>103</b>	<b>mA Input Offset</b> Use <i>mA Input Offset</i> to set the offset applied to the raw analog value of the milli amp input before the scale factor is applied. This lets you shift the range of the analog input.	<b>Parameter number</b>	103
		<b>File:group</b>	Interface/Comm:Analog Inputs
		<b>Parameter type</b>	linkable destination
		<b>Display</b>	±x.xxx mA
		<b>Factory default</b>	+0.000 mA
		<b>Minimum value</b>	-32.000 mA
		<b>Maximum value</b>	+32.000 mA
		<b>Conversion</b>	128 = 1.000
<b>104</b>	<b>mA Input Scale</b> Enter the scale factor or gain for the milli amp input. The milli amp input is converted to +2048 and then the scale is applied. This provides an effective digital range of ±32767.	<b>Parameter number</b>	104
		<b>File:group</b>	Interface/Comm:Analog Inputs
		<b>Parameter type</b>	linkable destination
		<b>Display</b>	±x.xxx
		<b>Factory default</b>	+2.000
		<b>Minimum value</b>	-16.000
		<b>Maximum value</b>	+16.000
		<b>Conversion</b>	2048 = 1.000
<b>105</b>	<b>An Out 1 Value</b> Use <i>An Out 1 Value</i> to convert a +32767 digital value to a +10 volt output. This is the value of the analog output number 1.	<b>Parameter number</b>	105
		<b>File:group</b>	Interface/Comm:Analog Outputs
		<b>Parameter type</b>	linkable destination
		<b>Display</b>	±x
		<b>Factory default</b>	+0
		<b>Minimum value</b>	-32767
		<b>Maximum value</b>	+32767
		<b>Conversion</b>	1 = 1



<b>106</b>	<b>An Out 1 Offset</b> Use <i>An Out 1 Offset</i> to set the offset applied to the raw analog output 1. The offset is applied after the scale factor.	<b>Parameter number</b>	106
		<b>File:group</b>	Interface/Comm:Analog Outputs
		<b>Parameter type</b>	linkable destination
		<b>Display</b>	±x.xxx volts
		<b>Factory default</b>	+0.000 volts
		<b>Minimum value</b>	-20.000 volts
		<b>Maximum value</b>	+20.000 volts
	<b>Conversion</b>	205 = 1.000	
<b>107</b>	<b>An Out 1 Scale</b> Use <i>An Out 1 Scale</i> to set the scale factor or gain for analog output 1. A +32767 digital value is converted by the scale factor. This allows an effective digital range of +2048 which is then offset to provide a +10 volt range.	<b>Parameter number</b>	107
		<b>File:group</b>	Interface/Comm:Analog Outputs
		<b>Parameter type</b>	linkable destination
		<b>Display</b>	±x.xxx
		<b>Factory default</b>	+0.500
		<b>Minimum value</b>	-1.000
		<b>Maximum value</b>	+1.000
	<b>Conversion</b>	32767 = 1.000	
<b>108</b>	<b>An Out 2 Value</b> Use <i>An Out 2 Value</i> to convert a +32767 digital value to a +10 volt output. This is the value of the analog output number 2.	<b>Parameter number</b>	108
		<b>File:group</b>	Interface/Comm:Analog Outputs
		<b>Parameter type</b>	linkable destination
		<b>Display</b>	±x
		<b>Factory default</b>	+0
		<b>Minimum value</b>	-32767
		<b>Maximum value</b>	+32767
	<b>Conversion</b>	1 = 1	
<b>109</b>	<b>An Out 2 Offset</b> Use <i>An Out 2 Offset</i> to set the offset applied to the raw analog output 2. The offset is applied after the scale factor.	<b>Parameter number</b>	109
		<b>File:group</b>	Interface/Comm:Analog Outputs
		<b>Parameter type</b>	linkable destination
		<b>Display</b>	±x.xxx volts
		<b>Factory default</b>	+0.000 volts
		<b>Minimum value</b>	-19.980 volts
		<b>Maximum value</b>	+19.980 volts
	<b>Conversion</b>	205 = 1.000	
<b>110</b>	<b>An Out 2 Scale</b> Use <i>An Out 2 Scale</i> to set the scale factor or gain for analog output 2. A +32767 digital value is converted by the scale factor. This allows an effective digital range of +2048 which is then offset to provide a +10 volt range.	<b>Parameter number</b>	110
		<b>File:group</b>	Interface/Comm:Analog Outputs
		<b>Parameter type</b>	linkable destination
		<b>Display</b>	±x.xxx
		<b>Factory default</b>	+0.500
		<b>Minimum value</b>	-1.000
		<b>Maximum value</b>	+1.000
	<b>Conversion</b>	32767 = 1.000	
<b>111</b>	<b>mA Out Value</b> Use <i>mA Out Value</i> to convert a +32767 digital value to a 4 – 20 mA output. This is the value of the mA output.	<b>Parameter number</b>	111
		<b>File:group</b>	Interface/Comm:Analog Outputs
		<b>Parameter type</b>	linkable destination
		<b>Display</b>	±x
		<b>Factory default</b>	+0
		<b>Minimum value</b>	-32767
		<b>Maximum value</b>	+32767
	<b>Conversion</b>	1 = 1	

<b>112</b>	<b>mA Out Offset</b> Use <i>mA Out Offset</i> to set the offset applied to the raw milli amp output. The offset is applied after the scale factor.	<b>Parameter number</b>	112
		<b>File:group</b>	Interface/Comm:Analog Outputs
		<b>Parameter type</b>	linkable destination
		<b>Display</b>	±x.xxx mA
		<b>Factory default</b>	+0.000 mA
		<b>Minimum value</b>	-32.000 mA
		<b>Maximum value</b>	+32.000 mA
	<b>Conversion</b>	128 = 1.000	

<b>113</b>	<b>mA Out Scale</b> Use <i>mA Out Scale</i> to set the scale factor or gain for milli amp output. A +32767 digital value is converted by the scale factor. This allows an effective digital range of +2048 which is then offset to provide a +20 mA range.	<b>Parameter number</b>	113
		<b>File:group</b>	Interface/Comm:Analog Outputs
		<b>Parameter type</b>	linkable destination
		<b>Display</b>	±x.xxx
		<b>Factory default</b>	+0.500
		<b>Minimum value</b>	-1.000
		<b>Maximum value</b>	+1.000
	<b>Conversion</b>	32767 = 1.000	

<b>114</b>	<b>Relay Config 1</b> Use <i>Relay Config 1</i> to select the function of terminal 1 on either TB10 (for frames A1 – A4) or TB11 (for frames B – H) output.  <i>Relay Config 1</i> may be any one of the following values:	<b>Parameter number</b>	114
		<b>File:group</b>	Interface/Comm:Digital Config
		<b>Parameter type</b>	destination
		<b>Display</b>	x
		<b>Factory default</b>	13
		<b>Minimum value</b>	0
		<b>Maximum value</b>	36
	<b>Conversion</b>	1 = 1	

Value	Description
0	<b>Disabled</b> The relay is disabled.
1	<b>Run Ready</b> The drive is ready to run.
2	<b>Not Run Rdy</b> The drive is not ready to run.
3	<b>Running</b> Commanded speed is not zero.
4	<b>Not Running</b> Commanded speed is zero.
5	<b>Stopping</b> The drive is stopping.
6	<b>Not Stopping</b> The drive is not stopping.
7	<b>Stopped</b> The drive is stopped.
8	<b>Not Stopped</b> The drive is not stopped.
9	<b>Accelerating</b> The motor is accelerating.
10	<b>Not Accel</b> The motor is not accelerating.
11	<b>Decelerating</b> The motor is decelerating.
12	<b>Not Decel</b> The motor is not decelerating.
13	<b>At Set Speed</b> The motor is at the requested speed.
14	<b>Not Set Sp</b> The motor is not at the requested speed.
15	<b>At Zero Spd</b> The motor is at zero speed.

Value	Description
16	<b>Not Zero Spd</b> The motor is not at zero speed.
17	<b>Flux Ready</b> The motor is ready to be fluxed up.
18	<b>Not Flux Rdy</b> The motor is not ready to be fluxed up.
19	<b>Flux Up</b> The drive feels the motor is fluxed up.
20	<b>Not Flux Up</b> The drive feels the motor is not fluxed up.
21	<b>Jogging</b> The motor is jogging.
22	<b>Not Jogging</b> The motor is not jogging.
23	<b>At Limit</b> The motor is at the limit shown in <i>Torque Limit Sts</i> (parameter 87).
24	<b>Not At Lim</b> The motor is not at the limit shown in <i>Torque Limit Sts</i> (parameter 87).
25	<b>&gt;= Speed</b> The motor speed is greater than or equal to <i>Relay Setpoint 1</i> (parameter 115).
26	<b>&lt; Speed</b> The motor speed is less than <i>Relay Setpoint 1</i> (parameter 115).
27	<b>&gt;=Current</b> The motor current is greater than or equal to <i>Relay Setpoint 1</i> (parameter 115).
28	<b>&lt;Current</b> The motor current is less than <i>Relay Setpoint 1</i> (parameter 115).

Value	Description
29	<b>Faulted<sup>1</sup></b> <b>A fault has occurred.</b>
30	<b>Not Faulted<sup>1</sup></b> A fault has not occurred.
31	<b>Warning<sup>1</sup></b> A warning has occurred.
32	<b>Not Warning<sup>1</sup></b> A warning has not occurred.
33	<b>Enable<sup>1</sup></b> Power is being applied to the motor.
34	<b>Not Enable<sup>1</sup></b> Power is not being applied to the motor.
35	<b>Function Val<sup>1</sup></b> True when the value of <i>Function Output 1</i> (par. 213) and/or the value of <i>Function Output 2</i> (par. 214) are zero.
36	<b>Not Function Val<sup>1</sup></b> True when the values of both <i>Function Output 1</i> (par. 213) and <i>Function Output 2</i> (par. 214) are zero.
37	<b>Function T/F</b> True when timer or logical state of add/sub or mult/div is true based on the selected function block.
38	<b>Not Function T/F</b> False when timer or logical state of add/sub or mult/div is false based on the selected function block.

1 Added for Version 2.xx.

<b>115 Relay Setpoint 1</b>	<i>Relay Setpoint 1</i> lets you specify the setpoint threshold for either speed or current. <i>Relay Setpoint 1</i> is only active if <i>Relay Config 1</i> (parameter 114) is set to a value of 25, 26, 27, or 28.	<b>Parameter number</b>	115
		<b>File:group</b>	Interface/Comm:Digital Config
		<b>Parameter type</b>	linkable destination
		<b>Display</b>	±x.x%
		<b>Factory default</b>	+0.0%
		<b>Minimum value</b>	-800.0%
		<b>Maximum value</b>	+800.0%
<b>Conversion</b>	4096 = 100.0%		

<b>116 L Option Mode</b>	Use <i>L Option Mode</i> to select the functions of L Option inputs at TB3. If you change the value of <i>L Option Mode</i> , you must cycle power before the change will take effect.	<b>Parameter number</b>	116
		<b>File:group</b>	Interface/Comm:Digital Config
		<b>Parameter type</b>	destination
		<b>Display</b>	x
		<b>Factory default</b>	1
		<b>Minimum value</b>	1
		<b>Maximum value</b>	32
<b>Conversion</b>	1 = 1		
The following is the mode information:		Refer to Chapter 5, <i>Using the L Option</i> , for additional information.	

Mode	TB3-19	TB3-20	TB3-22	TB3-23	TB3-24	TB3-26	TB3-27	TB3-28
1	Status	Stop	Status	Status	Status	Status	Status	Status
2	Start	Stop	Rev/Fwd	Jog	Ext Fault	Spd 3	Spd 2	Spd 1
3	Start	Stop	Rev/Fwd	2/1 Stop Type	Ext Fault	Spd 3	Spd 2	Spd 1
4	Start	Stop	Rev/Fwd	2/1 Accel	Ext Fault	2/1 Decel	Spd 2	Spd 1
5	Start	Stop	Rev/Fwd	Pot Up	Ext Fault	Pot Dn	Spd 2	Spd 1
6	Start	Stop	Rev/Fwd	Jog	Ext Fault	Loc/Rem	Spd 2	Spd 1
7	Start	Stop	Rev	Fwd	Ext Fault	Jog	Spd 2	Spd 1
8	Start	Stop	Rev	Fwd	Ext Fault	Spd 3	Spd 2	Spd 1
9	Start	Stop	Pot Up	Pot Dn	Ext Fault	Spd 3	Spd 2	Spd 1
10	Start	Stop	Rev	Fwd	Ext Fault	Pot Up	Pot Dn	Spd 1
11	Start	Stop	1st Accel	2nd Accel	Ext Fault	1st Decel	2nd Decel	Spd 1
12	Run Fwd	Stop	Run Rev	Loc/Rem	Ext Fault	Spd 3	Spd 2	Spd 1
13	Run Fwd	Stop	Run Rev	2/1 Stop Type	Ext Fault	Spd 3	Spd 2	Spd 1
14	Run Fwd	Stop	Run Rev	2/1 Accel	Ext Fault	2/1 Decel	Spd 2	Spd 1
15	Run Fwd	Stop	Run Rev	Pot Up	Ext Fault	Pot Dn	Spd 2	Spd 1
16	Run Fwd	Stop	Run Rev	Loc/Rem	Ext Fault	2/1 Stop Type	Spd 2	Spd 1
17	Start	Stop	Rev/Fwd	Proc Trim	Ext Fault	Ramp	Spd 2	Spd 1
18	Start	Stop	Rev/Fwd	Flux En	Ext Fault	Reset	Spd 2	Spd 1
19	Start	Stop	Spd/Trq 3	Spd/Trq 2	Ext Fault	Spd/Trq 1	Proc Trim	Spd 1
20	Start	Stop	Spd/Trq 3	Spd/Trq 2	Ext Fault	Spd/Trq 1	Flux En	Spd 1
21	Start	Stop	Rev	Fwd	Ext Fault	Ramp	Reset	Spd 1
22	Start	Stop	Spd/Trq 3	Spd/Trq 2	Ext Fault	Spd/Trq 1	Spd 2	Spd 1
23	Run Fwd	Stop	Run Rev	Proc Trim	Ext Fault	Reset	Spd 2	Spd 1
24	Run Fwd	Stop	Run Rev	Flux En	Ext Fault	Reset	Spd 2	Spd 1
25	Run Fwd	Stop	Run Rev	Proc Trim	Ext Fault	Ramp	Spd 2	Spd 1
26 <sup>1</sup>	Run Fwd	Stop	Run Rev	Jog	Ext Fault	Spd 3	Spd 2	Spd 1
27 <sup>2</sup>	Start	Stop	Rev/Fwd	Pot Up	Ext Fault	Pot Dn	Spd 2	Spd 1
28 <sup>2</sup>	Start	Stop	Pot Up	Pot Dn	Ext Fault	Spd 3	Spd 2	Spd 1
29 <sup>2</sup>	Start	Stop	Rev	Fwd	Ext Fault	Pot Up	Pot Dn	Spd 1
30 <sup>2</sup>	Run Fwd	Stop	Run Rev	Pot Up	Ext Fault	Pot Dn	Spd 2	Spd 1
31 <sup>3</sup>	Step Trigger	Not Stop	Step Trigger	Step Trigger	Not Ext Flt	Step Trigger	Step Trigger	Step Trigger
32 <sup>3</sup>	Start	Not Stop	Step Trigger	Step Trigger	Not Ext Flt	Profile Enable	Run Sequence	Step Hold

1 Added for Version 2.01.

2 Added for Version 2.02

3 Added for Version 4.01

<b>117</b>	<b>L Option In Sts</b>		Use <i>L Option In Sts</i> to view the status of the L Option inputs.		<b>Parameter number</b>	117
					<b>File:group</b>	Interface/Comm:Digital Config
					<b>Parameter type</b>	source
					<b>Display</b>	bits
					<b>Factory default</b>	not applicable
					<b>Minimum value</b>	00000000.00000000
					<b>Maximum value</b>	00000001.11111111
					<b>Conversion</b>	1 = 1

Bit	Description	Bit	Description	Bit	Description	Bit	Description
0	<b>TB3-19</b>	3	<b>TB3-23</b>	6	<b>TB3-27</b>	9 – 15	<b>Reserved</b>
1	<b>TB3-20</b>	4	<b>TB3-24</b>	7	<b>TB3-28</b>		Leave 0.
2	<b>TB3-22</b>	5	<b>TB3-26</b>	8	<b>TB3-30 (enable)</b>		

<b>118</b>	<b>Mop Increment</b>		Use <i>Mop Increment</i> to set the rate of increase or decrease to the Manually Operated Potentiometer (MOP) value based on rpm/second. <i>Mop Increment</i> is only used when the value of <i>L Option Mode</i> (parameter 116) is 5, 9, 10, or 15.		<b>Parameter number</b>	118
					<b>File:group</b>	Interface/Comm:Digital Config
					<b>Parameter type</b>	linkable destination
					<b>Display</b>	x.x rpm (rpm/second)
					<b>Factory default</b>	10% of base motor speed
					<b>Minimum value</b>	0.0
					<b>Maximum value</b>	base motor speed
					<b>Conversion</b>	4096 = base motor speed

Refer to Chapter 9, *Applications*, for more information.

<b>119</b>	<b>Mop Value</b>		Use <i>Mop Value</i> to view the Manually Operated Potentiometer (MOP) value. You need to link <i>Mop Value</i> to a reference, such as <i>Speed Ref 1</i> (parameter 29) for the drive to follow the Mop command for speed.		<b>Parameter number</b>	119
					<b>File:group</b>	Interface/Comm:Digital Config
					<b>Parameter type</b>	source
					<b>Display</b>	±x.x rpm
					<b>Factory default</b>	not applicable
					<b>Minimum value</b>	0.0
					<b>Maximum value</b>	base motor speed
					<b>Conversion</b>	4096 = base motor speed

Refer to Chapter 9, *Applications*, for more information.

<b>120</b>	<b>Pulse In PPR</b>		Use <i>Pulse In PPR</i> to set the number of pulses per revolution.		<b>Parameter number</b>	120
					<b>File:group</b>	Interface/Comm:Digital Config
					<b>Parameter type</b>	destination
					<b>Display</b>	x PPR
					<b>Factory default</b>	1024
					<b>Minimum value</b>	500
					<b>Maximum value</b>	20000
					<b>Conversion</b>	1 = 1

Refer to Chapter 7, *Setting Up the Input/Output*, for more information.

<b>121</b>	<b>Pulse In Scale</b>		Enter the value to use to scale the pulse input. The scale is a ratio. For example, you would enter 0.5 if you want to scale the pulse input to half.		<b>Parameter number</b>	121
					<b>File:group</b>	Interface/Comm:Digital Config
					<b>Parameter type</b>	destination
					<b>Display</b>	x.xx
					<b>Factory default</b>	1.00
					<b>Minimum value</b>	0.01
					<b>Maximum value</b>	10.00
					<b>Conversion</b>	100 = 1.00

Refer to Chapter 7, *Setting Up the Input/Output*, for more information.

<b>122</b>	<b>Pulse In Offset</b> Enter the minimum speed the pulse input will go to.	<b>Parameter number</b>	122
		<b>File:group</b>	Interface/Comm:Digital Config destination
<b>123</b>	<b>Pulse In Value</b> Use <i>Pulse In Value</i> to view the pulse input value. You need to link <i>Pulse In Value</i> to a reference parameter.	<b>Parameter type</b>	±x.x rpm
		<b>Display</b>	±x.x rpm
		<b>Factory default</b>	+0.0
		<b>Minimum value</b>	-base motor speed
		<b>Maximum value</b>	+base motor speed
		<b>Conversion</b>	4096 = base motor speed
		Refer to Chapter 7, <i>Setting Up the Input/Output</i> , for more information.	
		<b>Parameter number</b>	123
<b>File:group</b>	Interface/Comm:Digital Config source		
<b>Parameter type</b>	±x.x rpm		
<b>Display</b>	not applicable		
<b>Factory default</b>	0.0		
<b>Minimum value</b>	+8 x base motor speed		
<b>Maximum value</b>	4096 = base motor speed		
<b>Conversion</b>	4096 = base motor speed		
Refer to Chapter 7, <i>Setting Up the Input/Output</i> , for more information.			
<b>124</b>	<b>SP Enable Mask</b> Use <i>SP Enable Mask</i> to select which SCANport devices can control the drive. You can choose between: 0 = Disable control 1 = Enable control Stop is always active, even if you disable a device. The bits are defined as follows:	<b>Parameter number</b>	124
		<b>File:group</b>	Interface/Comm:SCANport Config linkable destination
<b>Parameter type</b>	bits	<b>Factory default</b>	11111111
<b>Display</b>	bits	<b>Minimum value</b>	00000000
<b>Factory default</b>	11111111	<b>Maximum value</b>	11111111
<b>Minimum value</b>	00000000	<b>Conversion</b>	1 = 1
<b>Maximum value</b>	11111111	Refer to Chapter 8, <i>Using the SCANport Capabilities</i> , for more information.	
<b>Conversion</b>	1 = 1		
<b>Bit</b>	<b>Description</b>	<b>Bit</b>	<b>Description</b>
0	<b>Enable L Opt</b> Enable the L Option board.	3	<b>Enable SP 3</b> Enable SCANport device 3.
1	<b>Enable SP 1</b> Enable SCANport device 1.	4	<b>Enable SP 4</b> Enable SCANport device 4.
2	<b>Enable SP 2</b> Enable SCANport device 2.	5	<b>Enable SP 5</b> Enable SCANport device 5.
		6	<b>Enable SP 6</b> Enable SCANport device 6.
		7	<b>Enable P197</b> Enable <i>Logic Cmd Input</i> (parameter 197).

**125 Dir/Ref Mask**

You can use the lower byte of *Dir/Ref Mask* (bits 0 through 7) to select which SCANport device can issue a reference command. You can use the higher byte (bits 8 through 15) to select which SCANport devices can issue a forward/reverse direction command. You can choose between:

- 0 = Disable control
- 1 = Enable control

The bits are defined as follows:

Bit	Description	Bit	Description	Bit	Description
0	<b>Refer L Opt</b> Let the L Option board control the reference.	6	<b>Refer SP 6</b> Let SCANport device 6 control the reference.	12	<b>Direct SP 4</b> Let SCANport device 4 control the direction.
1	<b>Refer SP 1</b> Let SCANport device 1 control the reference.	7	<b>Refer P197</b> Let <i>Logic Cmd Input</i> (parameter 197) control the reference.	13	<b>Direct SP 5</b> Let SCANport device 5 control the direction.
2	<b>Refer SP 2</b> Let SCANport device 2 control the reference.	8	<b>Direct L Opt</b> Let the L Option board control the direction.	14	<b>Direct SP 6</b> Let SCANport device 6 control the direction.
3	<b>Refer SP 3</b> Let SCANport device 3 control the reference.	9	<b>Direct SP 1</b> Let SCANport device 1 control the direction.	15	<b>Direct P197</b> Let <i>Logic Cmd Input</i> (parameter 197) control the direction.
4	<b>Refer SP 4</b> Let SCANport device 4 control the reference.	10	<b>Direct SP 2</b> Let SCANport device 2 control the direction.		
5	<b>Refer SP 5</b> Let SCANport device 5 control the reference.	11	<b>Direct SP 3</b> Let SCANport device 3 control the direction.		

<b>Parameter number</b>	125
<b>File:group</b>	Interface/Comm:SCANport Config
<b>Parameter type</b>	linkable destination
<b>Display</b>	bits
<b>Factory default</b>	11111111.11111111
<b>Minimum value</b>	00000000.00000000
<b>Maximum value</b>	11111111.11111111
<b>Conversion</b>	1 = 1

Refer to Chapter 8, *Using the SCANport Capabilities*, for more information.

**126 Start/Jog Mask**

You can use the lower byte of *Start/Jog Mask* (bits 0 through 7) to select which SCANport devices can issue a jog reference command. You can use the higher byte (bits 8 through 15) to select which SCANport devices can issue a start command. You can choose between:

- 0 = Disable control
- 1 = Enable control

The bits are defined as follows:

Bit	Description	Bit	Description	Bit	Description
0	<b>Jog L Opt</b> Let the L Option board control jogs.	6	<b>Jog SP 6</b> Let SCANport device 6 control jogs.	12	<b>Start SP 4</b> Let SCANport device 4 control starts.
1	<b>Jog SP 1</b> Let SCANport device 1 control jogs.	7	<b>Jog P197</b> Let <i>Logic Cmd Input</i> (parameter 197) control jogs.	13	<b>Start SP 5</b> Let SCANport device 5 control starts.
2	<b>Jog SP 2</b> Let SCANport device 2 control jogs.	8	<b>Start L Opt</b> Let the L Option board control starts.	14	<b>Start SP 6</b> Let SCANport device 6 control starts.
3	<b>Jog SP 3</b> Let SCANport device 3 control jogs.	9	<b>Start SP 1</b> Let SCANport device 1 control starts.	15	<b>Start P197</b> Let <i>Logic Cmd Input</i> (parameter 197) control starts.
4	<b>Jog SP 4</b> Let SCANport device 4 control jogs.	10	<b>Start SP 2</b> Let SCANport device 2 control starts.		
5	<b>Jog SP 5</b> Let SCANport device 5 control jogs.	11	<b>Start SP 3</b> Let SCANport device 3 control starts.		

<b>Parameter number</b>	126
<b>File:group</b>	Interface/Comm:SCANport Config
<b>Parameter type</b>	linkable destination
<b>Display</b>	bits
<b>Factory default</b>	11111111.11111111
<b>Minimum value</b>	00000000.00000000
<b>Maximum value</b>	11111111.11111111
<b>Conversion</b>	1 = 1

Refer to Chapter 8, *Using the SCANport Capabilities*, for more information.

**127 Clr Fit/Res Mask**

You can use the lower byte of *Clr Fit/Res Mask* (bits 0 through 7) to select which SCANport devices can issue a Reset Drive command. You can use the higher byte (bits 8 through 15) to select which SCANport devices can issue a Clear Faults command. You can choose between:

0 = Disable control  
1 = Enable control

The bits are defined as follows:

Bit	Description	Bit	Description	Bit	Description
0	<b>Reset L Opt</b> Let the L Option board control resets.	6	<b>Reset SP 6</b> Let SCANport device 6 control resets.	12	<b>ClrFit SP 4</b> Let SCANport device 4 control clear fault commands.
1	<b>Reset SP 1</b> Let SCANport device 1 control resets.	7	<b>Reset P197</b> Let <i>Logic Cmd Input</i> (parameter 197) control resets.	13	<b>ClrFit SP 5</b> Let SCANport device 5 control clear fault commands.
2	<b>Reset SP 2</b> Let SCANport device 2 control resets.	8	<b>ClrFit L Opt</b> Let the L Option board control clear fault commands.	14	<b>ClrFit SP 6</b> Let SCANport device 6 control clear fault commands.
3	<b>Reset SP 3</b> Let SCANport device 3 control resets.	9	<b>ClrFit SP 1</b> Let SCANport device 1 control clear fault commands.	15	<b>ClrFit P197</b> Let <i>Logic Cmd Input</i> (parameter 197) control clear fault commands.
4	<b>Reset SP 4</b> Let SCANport device 4 control resets.	10	<b>ClrFit SP 2</b> Let SCANport device 2 control clear fault commands.		
5	<b>Reset SP 5</b> Let SCANport device 5 control resets.	11	<b>ClrFit SP 3</b> Let SCANport device 3 control clear fault commands.		

<b>Parameter number</b>	127
<b>File:group</b>	Interface/Comm:SCANport Config
<b>Parameter type</b>	linkable destination
<b>Display</b>	bits
<b>Factory default</b>	11111111.11111111
<b>Minimum value</b>	00000000.00000000
<b>Maximum value</b>	11111111.11111111
<b>Conversion</b>	1 = 1
Refer to Chapter 8, <i>Using the SCANport Capabilities</i> , for more information.	

**128 Dir/Ref Owner**

You can use the lower byte of *Dir/Ref Owner* (bits 0 through 7) to see which SCANport device currently has exclusive control of the reference changes. You can use the higher byte (bits 8 through 15) to see which SCANport device currently has exclusive control of direction changes. You can choose between:

0 = Reference/direction input not present  
1 = Reference/direction input present

The bits are defined as follows:

Bit	Description	Bit	Description	Bit	Description
0	<b>Refer L Opt</b> The L Option board owns the reference command.	6	<b>Refer SP 6</b> SCANport device 6 owns the reference command.	11	<b>Direct SP 3</b> SCANport device 3 owns the direct command.
1	<b>Refer SP 1</b> SCANport device 1 owns the reference command.	7	<b>Refer P197</b> <i>Logic Cmd Input</i> (parameter 197) owns the reference command.	12	<b>Direct SP 4</b> SCANport device 4 owns the direct command.
2	<b>Refer SP 2</b> SCANport device 2 owns the reference command.	8	<b>Direct L Opt</b> The L Option board owns the direct command.	13	<b>Direct SP 5</b> SCANport device 5 owns the direct command.
3	<b>Refer SP 3</b> SCANport device 3 owns the reference command.	9	<b>Direct SP 1</b> SCANport device 1 owns the direct command.	14	<b>Direct SP 6</b> SCANport device 6 owns the direct command.
4	<b>Refer SP 4</b> SCANport device 4 owns the reference command.	10	<b>Direct SP 2</b> SCANport device 2 owns the direct command.	15	<b>Direct P197</b> <i>Logic Cmd Input</i> (parameter 197) owns the direct command.
5	<b>Refer SP 5</b> SCANport device 5 owns the reference command.				

<b>Parameter number</b>	128
<b>File:group</b>	Monitor Status:SCANport Status Interface/Comm:SCANport Status
<b>Parameter type</b>	source
<b>Display</b>	bits
<b>Factory default</b>	not applicable
<b>Minimum value</b>	00000000.00000000
<b>Maximum value</b>	11111111.11111111
<b>Conversion</b>	1 = 1
Refer to Chapter 8, <i>Using the SCANport Capabilities</i> , for more information.	

**129 Start/Stop Owner**

You can use the lower byte of *Start/Stop Owner* (bits 0 through 7) to see which SCANport device(s) are presently issuing a valid stop command. You can use the higher byte (bits 8 through 15) to see which SCANport device(s) are presently issuing a valid start command. You can choose between:

- 0 = Stop/start input not present
- 1 = Stop/start input present

The bits are defined as follows:

Bit	Description
0	<b>Stop L Opt</b> The L Option board owns the stop.
1	<b>Stop SP 1</b> SCANport device 1 owns the stop.
2	<b>Stop SP 2</b> SCANport device 2 owns the stop.
3	<b>Stop SP 3</b> SCANport device 3 owns the stop.
4	<b>Stop SP 4</b> SCANport device 4 owns the stop.
5	<b>Stop SP 5</b> SCANport device 5 owns the stop.

Bit	Description
6	<b>Stop SP 6</b> SCANport device 6 owns the stop.
7	<b>Stop P197</b> <i>Logic Cmd Input</i> (parameter 197) owns the stop.
8	<b>Start L Opt</b> The L Option owns the start.
9	<b>Start SP 1</b> SCANport device 1 owns the start.
10	<b>Start SP 2</b> SCANport device 2 owns the start.

Bit	Description
11	<b>Start SP 3</b> SCANport device 3 owns the start.
12	<b>Start SP 4</b> SCANport device 4 owns the start.
13	<b>Start SP 5</b> SCANport device 5 owns the start.
14	<b>Start SP 6</b> SCANport device 6 owns the start.
15	<b>Start P197</b> <i>Logic Cmd Input</i> (parameter 197) owns the start.

<b>Parameter number</b>	129
<b>File:group</b>	Monitor Status:SCANport Status Interface/Comm:SCANport Status
<b>Parameter type</b>	source
<b>Display</b>	bits
<b>Factory default</b>	not applicable
<b>Minimum value</b>	00000000.00000000
<b>Maximum value</b>	11111111.11111111
<b>Conversion</b>	1 = 1
Refer to Chapter 8, <i>Using the SCANport Capabilities</i> , for more information.	

**130 Jog1/Jog2 Owner**

You can use the lower byte of *Jog1/Jog2 Owner* (bits 0 through 7) to see which SCANport device(s) are presently issuing a valid jog 2 command. You can use the higher byte (bits 8 through 15) to see which SCANport device(s) are presently issuing a valid jog 1 command. You can choose between:

- 0 = Jog 1/jog 2 input not present
- 1 = Jog 1/jog 2 input present

The bits are defined as follows:

Bit	Description
0	<b>Jog2 L Opt</b> The L Option board owns the Jog2.
1	<b>Jog2 SP 1</b> SCANport device 1 owns the Jog2.
2	<b>Jog2 SP 2</b> SCANport device 2 owns the Jog2.
3	<b>Jog2 SP 3</b> SCANport device 3 owns the Jog2.
4	<b>Jog2 SP 4</b> SCANport device 4 owns the Jog2.
5	<b>Jog2 SP 5</b> SCANport device 5 owns the Jog2.

Bit	Description
6	<b>Jog2 SP 6</b> SCANport device 6 owns the Jog2.
7	<b>Jog2 P197</b> <i>Logic Cmd Input</i> (parameter 197) owns the Jog2.
8	<b>Jog1 L Opt</b> The L Option owns the Jog1.
9	<b>Jog1 SP 1</b> SCANport device 1 owns the Jog1.
10	<b>Jog1 SP 2</b> SCANport device 2 owns the Jog1.

Bit	Description
11	<b>Jog1 SP 3</b> SCANport device 3 owns the Jog1.
12	<b>Jog1 SP 4</b> SCANport device 4 owns the Jog1.
13	<b>Jog1 SP 5</b> SCANport device 5 owns the Jog1.
14	<b>Jog1 SP 6</b> SCANport device 6 owns the Jog1.
15	<b>Jog1 P197</b> <i>Logic Cmd Input</i> (parameter 197) owns the Jog1.

<b>Parameter number</b>	130
<b>File:group</b>	Monitor Status:SCANport Status Interface/Comm:SCANport Status
<b>Parameter type</b>	source
<b>Display</b>	bits
<b>Factory default</b>	not applicable
<b>Minimum value</b>	00000000.00000000
<b>Maximum value</b>	11111111.11111111
<b>Conversion</b>	1 = 1
Refer to Chapter 8, <i>Using the SCANport Capabilities</i> , for more information.	



**131 Ramp/CIFit Owner**

You can use the lower byte of *Ramp/CIFit Owner* (bits 0 through 7) to see which SCANport device(s) are presently issuing a valid Clear Fault command. You can use the higher byte (bits 8 through 15) to see which SCANport device(s) are presently issuing a valid ramp command. You can choose between:

0 = Ramp/clear fault input not present

1 = Ramp/clear fault input present

The bits are defined as follows:

Bit	Description	Bit	Description	Bit	Description
0	<b>ClrFit L Opt</b> The L Option board owns the Clear Fault.	5	<b>ClrFit SP 5</b> SCANport device 5 owns the Clear Fault.	11	<b>Ramp SP 3</b> SCANport device 3 owns the Ramp.
1	<b>ClrFit SP 1</b> SCANport device 1 owns the Clear Fault.	6	<b>ClrFit SP 6</b> SCANport device 6 owns the Clear Fault.	12	<b>Ramp SP 4</b> SCANport device 4 owns the Ramp.
2	<b>ClrFit SP 2</b> SCANport device 2 owns the Clear Fault.	7	<b>ClrFit P197</b> <i>Logic Cmd Input</i> (parameter 197) owns the Clear Fault.	13	<b>Ramp SP 5</b> SCANport device 5 owns the Ramp.
3	<b>ClrFit SP 3</b> SCANport device 3 owns the Clear Fault.	8	<b>Ramp L Opt</b> The L Option owns the Ramp.	14	<b>Ramp SP 6</b> SCANport device 6 owns the Ramp.
4	<b>ClrFit SP 4</b> SCANport device 4 owns the Clear Fault.	9	<b>Ramp SP 1</b> SCANport device 1 owns the Ramp.	15	<b>Ramp P197</b> <i>Logic Cmd Input</i> (parameter 197) owns the Ramp.
		10	<b>Ramp SP 2</b> SCANport device 2 owns the Ramp.		

<b>Parameter number</b>	131
<b>File:group</b>	Monitor Status:SCANport Status Interface/Comm:SCANport Status
<b>Parameter type</b>	source
<b>Display</b>	bits
<b>Factory default</b>	not applicable
<b>Minimum value</b>	00000000.00000000
<b>Maximum value</b>	11111111.11111111
<b>Conversion</b>	1 = 1
Refer to Chapter 8, <i>Using the SCANport Capabilities</i> , for more information.	

**132 Flux/Trim Owner**

You can use the lower byte of *Flux/Trim Owner* (bits 0 through 7) to see which SCANport device(s) are currently issuing a valid process trim command. You can use the higher byte (bits 8 through 15) to see which SCANport device(s) are presently issuing a valid flux command. You can choose between:

0 = Flux/trim input not present

1 = Flux/trim input present

The bits are defined as follows:

Bit	Description	Bit	Description	Bit	Description
0	<b>Trim L Opt</b> The L Option board owns the Trim.	6	<b>Trim SP 6</b> SCANport device 6 owns the Trim.	11	<b>Flux SP 3</b> SCANport device 3 owns the Flux.
1	<b>Trim SP 1</b> SCANport device 1 owns the Trim.	7	<b>Trim P197</b> <i>Logic Cmd Input</i> (parameter 197) owns the Trim.	12	<b>Flux SP 4</b> SCANport device 4 owns the Flux.
2	<b>Trim SP 2</b> SCANport device 2 owns the Trim.	8	<b>Flux L Opt</b> The L Option owns the Flux.	13	<b>Flux SP 5</b> SCANport device 5 owns the Flux.
3	<b>Trim SP 3</b> SCANport device 3 owns the Trim.	9	<b>Flux SP 1</b> SCANport device 1 owns the Flux.	14	<b>Flux SP 6</b> SCANport device 6 owns the Flux.
4	<b>Trim SP 4</b> SCANport device 4 owns the Trim.	10	<b>Flux SP 2</b> SCANport device 2 owns the Flux.	15	<b>Flux P197</b> <i>Logic Cmd Input</i> (parameter 197) owns the Flux.
5	<b>Trim SP 5</b> SCANport device 5 owns the Trim.				

<b>Parameter number</b>	132
<b>File:group</b>	Monitor Status:SCANport Status Interface/Comm:SCANport Status
<b>Parameter type</b>	source
<b>Display</b>	bits
<b>Factory default</b>	not applicable
<b>Minimum value</b>	00000000.00000000
<b>Maximum value</b>	11111111.11111111
<b>Conversion</b>	1 = 1
Refer to Chapter 8, <i>Using the SCANport Capabilities</i> , for more information.	

<p><b>133</b></p>	<p><b>SP An In1 Select</b></p> <p>Use <i>SP An In1 Select</i> to select which SCANport analog device is used in <i>SP An In1 Value</i> (parameter 134).</p>	<table border="0"> <tr> <td><b>Parameter number</b></td> <td style="text-align: right;">133</td> </tr> <tr> <td><b>File:group</b></td> <td style="text-align: right;">Interface/Comm:SCANport Analog</td> </tr> <tr> <td><b>Parameter type</b></td> <td style="text-align: right;">linkable destination</td> </tr> <tr> <td><b>Display</b></td> <td style="text-align: right;">x</td> </tr> <tr> <td><b>Factory default</b></td> <td style="text-align: right;">1</td> </tr> <tr> <td><b>Minimum value</b></td> <td style="text-align: right;">1</td> </tr> <tr> <td><b>Maximum value</b></td> <td style="text-align: right;">6</td> </tr> <tr> <td><b>Conversion</b></td> <td style="text-align: right;">1 = 1</td> </tr> </table>	<b>Parameter number</b>	133	<b>File:group</b>	Interface/Comm:SCANport Analog	<b>Parameter type</b>	linkable destination	<b>Display</b>	x	<b>Factory default</b>	1	<b>Minimum value</b>	1	<b>Maximum value</b>	6	<b>Conversion</b>	1 = 1
<b>Parameter number</b>	133																	
<b>File:group</b>	Interface/Comm:SCANport Analog																	
<b>Parameter type</b>	linkable destination																	
<b>Display</b>	x																	
<b>Factory default</b>	1																	
<b>Minimum value</b>	1																	
<b>Maximum value</b>	6																	
<b>Conversion</b>	1 = 1																	

Value	Description	Value	Description	Value	Description
1	<b>SP 1</b> Use SCANport device 1.	3	<b>SP 3</b> Use SCANport device 3.	5	<b>SP 5</b> Use SCANport device 5.
2	<b>SP 2</b> Use SCANport device 2.	4	<b>SP 4</b> Use SCANport device 4.	6	<b>SP 6</b> Use SCANport device 6.

<p><b>134</b></p>	<p><b>SP An In1 Value</b></p> <p>Use <i>SP An In1 Value</i> to view the analog value of the SCANport device selected in <i>SP An In1 Select</i> (parameter 133). You need to link <i>SP An In1 Value</i> to a parameter such as <i>Speed Ref 1</i> (parameter 29).</p>	<table border="0"> <tr> <td><b>Parameter number</b></td> <td style="text-align: right;">134</td> </tr> <tr> <td><b>File:group</b></td> <td style="text-align: right;">Interface/Comm:SCANport Analog</td> </tr> <tr> <td><b>Parameter type</b></td> <td style="text-align: right;">source</td> </tr> <tr> <td><b>Display</b></td> <td style="text-align: right;">±x</td> </tr> <tr> <td><b>Factory default</b></td> <td style="text-align: right;">not applicable</td> </tr> <tr> <td><b>Minimum value</b></td> <td style="text-align: right;">-32767</td> </tr> <tr> <td><b>Maximum value</b></td> <td style="text-align: right;">+32767</td> </tr> <tr> <td><b>Conversion</b></td> <td style="text-align: right;">1 = 1</td> </tr> </table>	<b>Parameter number</b>	134	<b>File:group</b>	Interface/Comm:SCANport Analog	<b>Parameter type</b>	source	<b>Display</b>	±x	<b>Factory default</b>	not applicable	<b>Minimum value</b>	-32767	<b>Maximum value</b>	+32767	<b>Conversion</b>	1 = 1
<b>Parameter number</b>	134																	
<b>File:group</b>	Interface/Comm:SCANport Analog																	
<b>Parameter type</b>	source																	
<b>Display</b>	±x																	
<b>Factory default</b>	not applicable																	
<b>Minimum value</b>	-32767																	
<b>Maximum value</b>	+32767																	
<b>Conversion</b>	1 = 1																	

<p><b>135</b></p>	<p><b>SP An In1 Scale</b></p> <p>Use <i>SP An In1 Scale</i> to scale <i>SP An In1 Value</i> (parameter 134).</p>	<table border="0"> <tr> <td><b>Parameter number</b></td> <td style="text-align: right;">135</td> </tr> <tr> <td><b>File:group</b></td> <td style="text-align: right;">Interface/Comm:SCANport Analog</td> </tr> <tr> <td><b>Parameter type</b></td> <td style="text-align: right;">linkable destination</td> </tr> <tr> <td><b>Display</b></td> <td style="text-align: right;">±x.xxx</td> </tr> <tr> <td><b>Factory default</b></td> <td style="text-align: right;">+0.125</td> </tr> <tr> <td><b>Minimum value</b></td> <td style="text-align: right;">-1.000</td> </tr> <tr> <td><b>Maximum value</b></td> <td style="text-align: right;">+1.000</td> </tr> <tr> <td><b>Conversion</b></td> <td style="text-align: right;">32767 = 1.000</td> </tr> </table>	<b>Parameter number</b>	135	<b>File:group</b>	Interface/Comm:SCANport Analog	<b>Parameter type</b>	linkable destination	<b>Display</b>	±x.xxx	<b>Factory default</b>	+0.125	<b>Minimum value</b>	-1.000	<b>Maximum value</b>	+1.000	<b>Conversion</b>	32767 = 1.000
<b>Parameter number</b>	135																	
<b>File:group</b>	Interface/Comm:SCANport Analog																	
<b>Parameter type</b>	linkable destination																	
<b>Display</b>	±x.xxx																	
<b>Factory default</b>	+0.125																	
<b>Minimum value</b>	-1.000																	
<b>Maximum value</b>	+1.000																	
<b>Conversion</b>	32767 = 1.000																	

<p><b>136</b></p>	<p><b>SP An In2 Select</b></p> <p>Use <i>SP An In2 Select</i> to select which SCANport analog device is used in <i>SP An In2 Value</i> (parameter 137).</p>	<table border="0"> <tr> <td><b>Parameter number</b></td> <td style="text-align: right;">136</td> </tr> <tr> <td><b>File:group</b></td> <td style="text-align: right;">Interface/Comm:SCANport Analog</td> </tr> <tr> <td><b>Parameter type</b></td> <td style="text-align: right;">linkable destination</td> </tr> <tr> <td><b>Display</b></td> <td style="text-align: right;">x</td> </tr> <tr> <td><b>Factory default</b></td> <td style="text-align: right;">6</td> </tr> <tr> <td><b>Minimum value</b></td> <td style="text-align: right;">1</td> </tr> <tr> <td><b>Maximum value</b></td> <td style="text-align: right;">6</td> </tr> <tr> <td><b>Conversion</b></td> <td style="text-align: right;">1 = 1</td> </tr> </table>	<b>Parameter number</b>	136	<b>File:group</b>	Interface/Comm:SCANport Analog	<b>Parameter type</b>	linkable destination	<b>Display</b>	x	<b>Factory default</b>	6	<b>Minimum value</b>	1	<b>Maximum value</b>	6	<b>Conversion</b>	1 = 1
<b>Parameter number</b>	136																	
<b>File:group</b>	Interface/Comm:SCANport Analog																	
<b>Parameter type</b>	linkable destination																	
<b>Display</b>	x																	
<b>Factory default</b>	6																	
<b>Minimum value</b>	1																	
<b>Maximum value</b>	6																	
<b>Conversion</b>	1 = 1																	

Value	Description	Value	Description	Value	Description
1	<b>SP 1</b> Use SCANport device 1.	3	<b>SP 3</b> Use SCANport device 3.	5	<b>SP 5</b> Use SCANport device 5.
2	<b>SP 2</b> Use SCANport device 2.	4	<b>SP 4</b> Use SCANport device 4.	6	<b>SP 6</b> Use SCANport device 6.

<p><b>137</b></p>	<p><b>SP An In2 Value</b></p> <p>Use <i>SP An In2 Value</i> to view the analog value of the SCANport device selected in <i>SP An In2 Select</i> (parameter 136). You need to link <i>SP An In2 Value</i> to a parameter such as <i>Speed Ref 1</i> (parameter 29).</p>	<table border="0"> <tr> <td><b>Parameter number</b></td> <td style="text-align: right;">137</td> </tr> <tr> <td><b>File:group</b></td> <td style="text-align: right;">Interface/Comm:SCANport Analog</td> </tr> <tr> <td><b>Parameter type</b></td> <td style="text-align: right;">source</td> </tr> <tr> <td><b>Display</b></td> <td style="text-align: right;">±x</td> </tr> <tr> <td><b>Factory default</b></td> <td style="text-align: right;">not applicable</td> </tr> <tr> <td><b>Minimum value</b></td> <td style="text-align: right;">-32767</td> </tr> <tr> <td><b>Maximum value</b></td> <td style="text-align: right;">+32767</td> </tr> <tr> <td><b>Conversion</b></td> <td style="text-align: right;">1 = 1</td> </tr> </table>	<b>Parameter number</b>	137	<b>File:group</b>	Interface/Comm:SCANport Analog	<b>Parameter type</b>	source	<b>Display</b>	±x	<b>Factory default</b>	not applicable	<b>Minimum value</b>	-32767	<b>Maximum value</b>	+32767	<b>Conversion</b>	1 = 1
<b>Parameter number</b>	137																	
<b>File:group</b>	Interface/Comm:SCANport Analog																	
<b>Parameter type</b>	source																	
<b>Display</b>	±x																	
<b>Factory default</b>	not applicable																	
<b>Minimum value</b>	-32767																	
<b>Maximum value</b>	+32767																	
<b>Conversion</b>	1 = 1																	

<b>138</b>	<b>SP An In2 Scale</b> Use <i>SP An In2 Scale</i> to scale <i>SP An In2 Value</i> (parameter 137).	<b>Parameter number</b>	138
		<b>File:group</b>	Interface/Comm:SCANport Analog
		<b>Parameter type</b>	linkable destination
		<b>Display</b>	±x.xxx
		<b>Factory default</b>	+0.125
		<b>Minimum value</b>	-1.000
		<b>Maximum value</b>	+1.000
	<b>Conversion</b>	32767 = 1.000	
<b>139</b>	<b>SP An Output</b> Use <i>SP An Output</i> to view the analog value that is sent to all SCANport devices. <b>Note:</b> If a link is made or changed, you may have to power cycle the SCANport terminals to display the correct information.	<b>Parameter number</b>	139
		<b>File:group</b>	Interface/Comm:SCANport Analog
		<b>Parameter type</b>	linkable destination
		<b>Display</b>	±x
		<b>Factory default</b>	+0
		<b>Minimum value</b>	-32767
		<b>Maximum value</b>	+32767
	<b>Conversion</b>	1 = 1	
<b>140</b>	<b>Data In A1</b> Use <i>Data In A1</i> to view the SCANport to drive image that is received from some device on SCANport. This image may be referred to as the SCANport I/O image or a datalink in the manual for your communications module.	<b>Parameter number</b>	140
		<b>File:group</b>	Interface/Comm:Gateway Data In
		<b>Parameter type</b>	source
		<b>Display</b>	±x
		<b>Factory default</b>	not applicable
		<b>Minimum value</b>	-32767
		<b>Maximum value</b>	+32767
	<b>Conversion</b>	1 = 1	
<b>141</b>	<b>Data In A2</b> Use <i>Data In A2</i> to view the SCANport to drive image that is received from some device on SCANport. This image may be referred to as the SCANport I/O image or a datalink in the manual for your communications module.	<b>Parameter number</b>	141
		<b>File:group</b>	Interface/Comm:Gateway Data In
		<b>Parameter type</b>	source
		<b>Display</b>	±x
		<b>Factory default</b>	not applicable
		<b>Minimum value</b>	-32767
		<b>Maximum value</b>	+32767
	<b>Conversion</b>	1 = 1	
<b>142</b>	<b>Data In B1</b> Use <i>Data In B1</i> to view the SCANport to drive image that is received from some device on SCANport. This image may be referred to as the SCANport I/O image or a datalink in the manual for your communications module.	<b>Parameter number</b>	142
		<b>File:group</b>	Interface/Comm:Gateway Data In
		<b>Parameter type</b>	source
		<b>Display</b>	±x
		<b>Factory default</b>	not applicable
		<b>Minimum value</b>	-32767
		<b>Maximum value</b>	+32767
	<b>Conversion</b>	1 = 1	
<b>143</b>	<b>Data In B2</b> Use <i>Data In B2</i> to view the SCANport to drive image that is received from some device on SCANport. This image may be referred to as the SCANport I/O image or a datalink in the manual for your communications module.	<b>Parameter number</b>	143
		<b>File:group</b>	Interface/Comm:Gateway Data In
		<b>Parameter type</b>	source
		<b>Display</b>	±x
		<b>Factory default</b>	not applicable
		<b>Minimum value</b>	-32767
		<b>Maximum value</b>	+32767
	<b>Conversion</b>	1 = 1	

<b>144</b>	<b>Data In C1</b>  Use <i>Data In C1</i> to view the SCANport to drive image that is received from some device on SCANport. This image may be referred to as the SCANport I/O image or a datalink in the manual for your communications module.	<b>Parameter number</b>	144
		<b>File:group</b>	Interface/Comm:Gateway Data In
		<b>Parameter type</b>	source
		<b>Display</b>	±x
		<b>Factory default</b>	not applicable
		<b>Minimum value</b>	-32767
		<b>Maximum value</b>	+32767
	<b>Conversion</b>	1 = 1	
<b>145</b>	<b>Data In C2</b>  Use <i>Data In C2</i> to view the SCANport to drive image that is received from some device on SCANport. This image may be referred to as the SCANport I/O image or a datalink in the manual for your communications module.	<b>Parameter number</b>	145
		<b>File:group</b>	Interface/Comm:Gateway Data In
		<b>Parameter type</b>	source
		<b>Display</b>	±x
		<b>Factory default</b>	not applicable
		<b>Minimum value</b>	-32767
		<b>Maximum value</b>	+32767
	<b>Conversion</b>	1 = 1	
<b>146</b>	<b>Data In D1</b>  Use <i>Data In D1</i> to view the SCANport to drive image that is received from some device on SCANport. This image may be referred to as the SCANport I/O image or a datalink in the manual for your communications module.	<b>Parameter number</b>	146
		<b>File:group</b>	Interface/Comm:Gateway Data In
		<b>Parameter type</b>	source
		<b>Display</b>	±x
		<b>Factory default</b>	not applicable
		<b>Minimum value</b>	-32767
		<b>Maximum value</b>	+32767
	<b>Conversion</b>	1 = 1	
<b>147</b>	<b>Data In D2</b>  Use <i>Data In D2</i> to view the SCANport to drive image that is received from some device on SCANport. This image may be referred to as the SCANport I/O image or a datalink in the manual for your communications module.	<b>Parameter number</b>	147
		<b>File:group</b>	Interface/Comm:Gateway Data In
		<b>Parameter type</b>	source
		<b>Display</b>	±x
		<b>Factory default</b>	not applicable
		<b>Minimum value</b>	-32767
		<b>Maximum value</b>	+32767
	<b>Conversion</b>	1 = 1	
<b>148</b>	<b>Data Out A1</b>  Use <i>Data Out A1</i> to view the drive to SCANport image that is sent to some device on SCANport. This image may be referred to as the SCANport I/O image or a datalink in the manual for your communications module.	<b>Parameter number</b>	148
		<b>File:group</b>	Interface/Comm:Gateway Data Out
		<b>Parameter type</b>	linkable destination
		<b>Display</b>	±x
		<b>Factory default</b>	+0
		<b>Minimum value</b>	-32767
		<b>Maximum value</b>	+32767
	<b>Conversion</b>	1 = 1	
<b>149</b>	<b>Data Out A2</b>  Use <i>Data Out A2</i> to view the drive to SCANport image that is sent to some device on SCANport. This image may be referred to as the SCANport I/O image or a datalink in the manual for your communications module.	<b>Parameter number</b>	149
		<b>File:group</b>	Interface/Comm:Gateway Data Out
		<b>Parameter type</b>	linkable destination
		<b>Display</b>	±x
		<b>Factory default</b>	+0
		<b>Minimum value</b>	-32767
		<b>Maximum value</b>	+32767
	<b>Conversion</b>	1 = 1	

<b>150</b>	<b>Data Out B1</b>  Use <i>Data Out B1</i> to view the drive to SCANport image that is sent to some device on SCANport. This image may be referred to as the SCANport I/O image or a datalink in the manual for your communications module.	<b>Parameter number</b>	150
		<b>File:group</b>	Interface/Comm:Gateway Data Out
		<b>Parameter type</b>	linkable destination
		<b>Display</b>	±x
		<b>Factory default</b>	+0
		<b>Minimum value</b>	-32767
		<b>Maximum value</b>	+32767
		<b>Conversion</b>	1 = 1
		<hr/>	
		<b>151</b>	<b>Data Out B2</b>  Use <i>Data Out B2</i> to view the drive to SCANport image that is sent to some device on SCANport. This image may be referred to as the SCANport I/O image or a datalink in the manual for your communications module.
<b>File:group</b>	Interface/Comm:Gateway Data Out		
		<b>Parameter type</b>	linkable destination
		<b>Display</b>	±x
		<b>Factory default</b>	+0
		<b>Minimum value</b>	-32767
		<b>Maximum value</b>	+32767
		<b>Conversion</b>	1 = 1
		<hr/>	
		<b>152</b>	<b>Data Out C1</b>  Use <i>Data Out C1</i> to view the drive to SCANport image that is sent to some device on SCANport. This image may be referred to as the SCANport I/O image or a datalink in the manual for your communications module.
<b>File:group</b>	Interface/Comm:Gateway Data Out		
		<b>Parameter type</b>	linkable destination
		<b>Display</b>	±x
		<b>Factory default</b>	+0
		<b>Minimum value</b>	-32767
		<b>Maximum value</b>	+32767
		<b>Conversion</b>	1 = 1
		<hr/>	
		<b>153</b>	<b>Data Out C2</b>  Use <i>Data Out C2</i> to view the drive to SCANport image that is sent to some device on SCANport. This image may be referred to as the SCANport I/O image or a datalink in the manual for your communications module.
<b>File:group</b>	Interface/Comm:Gateway Data Out		
		<b>Parameter type</b>	linkable destination
		<b>Display</b>	±x
		<b>Factory default</b>	+0
		<b>Minimum value</b>	-32767
		<b>Maximum value</b>	+32767
		<b>Conversion</b>	1 = 1
		<hr/>	
		<b>154</b>	<b>Data Out D1</b>  Use <i>Data Out D1</i> to view the drive to SCANport image that is sent to some device on SCANport. This image may be referred to as the SCANport I/O image or a datalink in the manual for your communications module.
<b>File:group</b>	Interface/Comm:Gateway Data Out		
		<b>Parameter type</b>	linkable destination
		<b>Display</b>	±x
		<b>Factory default</b>	+0
		<b>Minimum value</b>	-32767
		<b>Maximum value</b>	+32767
		<b>Conversion</b>	1 = 1
		<hr/>	
		<b>155</b>	<b>Data Out D2</b>  Use <i>Data Out D2</i> to view the drive to SCANport image that is sent to some device on SCANport. This image may be referred to as the SCANport I/O image or a datalink in the manual for your communications module.
<b>File:group</b>	Interface/Comm:Gateway Data Out		
		<b>Parameter type</b>	linkable destination
		<b>Display</b>	±x
		<b>Factory default</b>	+0
		<b>Minimum value</b>	-32767
		<b>Maximum value</b>	+32767
		<b>Conversion</b>	1 = 1
		<hr/>	

<b>156</b>	<b>Autotune Status</b>	<p><i>Autotune Status</i> provides information about the auto-tune procedure.</p> <p>The bits are defined as follows:</p>	<p><b>Parameter number</b> 156  <b>File:group</b> Autotune/Autotune Status  <b>Parameter type</b> source  <b>Display</b> bits  <b>Factory default</b> not applicable  <b>Minimum value</b> 00000000.00000000  <b>Maximum value</b> 00110000.11111111  <b>Conversion</b> 1 = 1</p> <p>Refer to Chapter 13, <i>Understanding the Auto-tuning Procedure</i>, for more information.</p>	
------------	------------------------	---	---	--

Bit	Description	Bit	Description	Bit	Description
0	<b>Executing</b> Auto-tune is currently executing.	4	<b>Flux Active</b> The motor has flux.	8 – 11	<b>Reserved</b> Leave 0.
1	<b>Complete</b> Auto-tune has completed.	5	<b>Not Ready</b> The drive is not ready to start auto-tune.	12	<b>Timeout</b> Auto-tune timed out. The inertia test failed to accelerate the load.
2	<b>Fail</b> An error was encountered.	6	<b>Not Zero Spd</b> The drive cannot start auto-tune.	13	<b>No Trq Lim</b> The inertia test failed to reach the torque limit.
3	<b>Abort</b> Auto-tune was aborted by a stop command.	7	<b>Running</b> The motor is running.	14 – 15	<b>Reserved</b> Leave 0.

<b>157</b>	<b>Total Inertia</b>	<p><i>Total Inertia</i> represents the time, in seconds, for a motor coupled to a load to accelerate from zero to base speed, at rated motor torque. The drive calculates <i>Total Inertia</i> during the auto-tune procedure when the auto-tune routines are run.</p> <p>The 1336 IMPACT drive uses <i>Total Inertia</i> and <i>Spd Desired BW</i> (parameter 161) to calculate the speed loop gains (parameters 158 and 159). If you cannot run the auto-tune inertia test, you should estimate <i>Total Inertia</i> and set it manually.</p>	<p><b>Parameter number</b> 157  <b>File:group</b> Control:Speed Regulator  Autotune:Autotune Results  <b>Parameter type</b> destination  <b>Display</b> x.xx second  <b>Factory default</b> 2.00 second  <b>Minimum value</b> 0.01 second  <b>Maximum value</b> 655.00 second  <b>Conversion</b> 100 = 1.00</p>	
------------	----------------------	---	---	--

<b>158</b>	<b>Ki Speed Loop</b>	<p>Use <i>Ki Speed Loop</i> to control the integral error gain of the speed regulator.</p> <p>The 1336 IMPACT drive automatically adjusts <i>Ki Speed Loop</i> when you enter a non-zero value for <i>Spd Desired BW</i> (parameter 161). Normally, you should adjust <i>Spd Desired BW</i> and let the drive calculate the gains. If manual adjustment is needed (for example, if the inertia cannot be determined), the drive sets <i>Spd Desired BW</i> to zero for you when this gain is changed.</p>	<p><b>Parameter number</b> 158  <b>File:group</b> Control:Speed Regulator  <b>Parameter type</b> linkable destination  <b>Display</b> x.x  <b>Factory default</b> 8.0  <b>Minimum value</b> 0.0  <b>Maximum value</b> 4095.9  <b>Conversion</b> 8 = 1.0</p>	
------------	----------------------	---	---	--

<b>159</b>	<b>Kp Speed Loop</b>	<p>Use <i>Kp Speed Loop</i> to control the proportional error gain of the speed regulator.</p> <p>The 1336 IMPACT drive automatically adjusts <i>Kp Speed Loop</i> when you enter a non-zero value for <i>Spd Desired BW</i> (parameter 161). Normally, you should adjust <i>Spd Desired BW</i> and let the drive calculate the gains. If manual gain adjustment is needed (for example, if the inertia cannot be determined), the drive sets <i>Spd Desired BW</i> to zero for you when this gain is changed.</p>	<p><b>Parameter number</b> 159  <b>File:group</b> Control:Speed Regulator  <b>Parameter type</b> linkable destination  <b>Display</b> x.x  <b>Factory default</b> 8.0  <b>Minimum value</b> 0.0  <b>Maximum value</b> 200.0  <b>Conversion</b> 8 = 1.0</p>	
------------	----------------------	--	--	--

160	<p><b>Kf Speed Loop</b></p> <p>Use <i>Kf Speed Loop</i> to control the feed forward gain of the speed regulator. Setting the Kf gain to less than one reduces speed feedback overshoot in response to a step change in speed reference.</p>	<p>Parameter number 160</p> <p>File:group Control:Speed Regulator</p> <p>Parameter type linkable destination</p> <p>Display x.xxx</p> <p>Factory default 1.000</p> <p>Minimum value 0.500</p> <p>Maximum value 1.000</p> <p>Conversion 65535 = 1.0</p>
161	<p><b>Spd Desired BW</b></p> <p>Use <i>Spd Desired BW</i> to specify the speed loop bandwidth and to determine the dynamic behavior of the speed loop. As you increase the bandwidth, the speed loop becomes more responsive and can track a faster changing speed reference. As you adjust the bandwidth setting, the 1336 IMPACT drive calculates and changes <i>Ki Speed Loop</i> (parameter 158) and <i>Kp Speed Loop</i> (parameter 159) gains. A zero bandwidth setting lets you adjust the speed loop gains independent of bandwidth for custom tuning applications.</p> <p><b>Note:</b> You must have the correct <i>Total Inertia</i> (parameter 157) entered before adjusting the speed loop bandwidth. <i>Total Inertia</i> is measured by the autotune (startup) routine.</p>	<p>Parameter number 161</p> <p>File:group Control:Speed Regulator Autotune:Autotune Results</p> <p>Parameter type linkable destination</p> <p>Display x.xx radians/second</p> <p>Factory default 5.00 radians/second</p> <p>Minimum value 0.00 radians/second</p> <p>Maximum value calculated</p> <p>Conversion 100 = 1</p>
162	<p><b>Error Filtr BW</b></p> <p>Use <i>Error Filtr BW</i> to set the bandwidths of two cascaded low pass filters in the Kf error path of the speed PI regulator.</p>	<p>Parameter number 162</p> <p>File:group Control:Speed Regulator</p> <p>Parameter type linkable destination</p> <p>Display x.x radians/second</p> <p>Factory default 500.0 radians/second</p> <p>Minimum value calculated</p> <p>Maximum value 1500.0 radians/second</p> <p>Conversion 10 = 1.0</p>
163	<p><b>Reserved</b></p> <p>Leave this parameter set to 0.</p>	<p>Parameter number 163</p> <p>File:group</p> <p>Parameter type</p> <p>Display</p> <p>Factory default</p> <p>Minimum value</p> <p>Maximum value</p> <p>Conversion</p>
164	<p><b>Autotune Torque</b></p> <p>Use <i>Autotune Torque</i> to specify the motor torque that is applied to the motor during the flux current and inertia tests.</p>	<p>Parameter number 164</p> <p>File:group Autotune:Autotune Setup</p> <p>Parameter type destination</p> <p>Display x.x%</p> <p>Factory default 50.0%</p> <p>Minimum value 25.0%</p> <p>Maximum value 100.0%</p> <p>Conversion 4096 = 100.0%</p>

165	<b>Autotune Speed</b>	Use <i>Autotune Speed</i> to set the maximum speed of the motor during the flux current and inertia tests.	<b>Parameter number</b> 165 <b>File:group</b> Autotune/Autotune Setup <b>Parameter type</b> destination <b>Display</b> $\pm x.x$ rpm <b>Factory default</b> base motor speed x 0.85 <b>Minimum value</b> base motor speed x 0.3 <b>Maximum value</b> base motor speed <b>Conversion</b> 4096 = base motor speed Refer to Chapter 13, <i>Understanding the Auto-tuning Procedure</i> , for more information.
166	<b>Stator Resistance</b>	Enter the sum of the stator and cable resistances of the motor in per unit (percent representation). The auto-tune procedure measures the stator resistance during the quick motor tune portion of start up.	<b>Parameter number</b> 166 <b>File:group</b> Motor/Inverter:Motor Constants Autotune/Autotune Results <b>Parameter type</b> destination <b>Display</b> x.xx% <b>Factory default</b> 1.49% <b>Minimum value</b> 0.00% <b>Maximum value</b> 100.00% <b>Conversion</b> 4096 = 100.00% Refer to Chapter 13, <i>Understanding the Auto-tuning Procedure</i> , for more information.
167	<b>Leak Inductance</b>	Enter the sum of the motor stator and rotor leakage inductances and the motor cable inductance in per unit (percent representation). The auto-tune procedure measures the leakage inductance during the quick motor tune portion of start up.	<b>Parameter number</b> 167 <b>File:group</b> Motor/Inverter:Motor Constants Autotune:Autotune Results <b>Parameter type</b> destination <b>Display</b> x.xx% <b>Factory default</b> 17.99% <b>Minimum value</b> 0.00% <b>Maximum value</b> 100.00% <b>Conversion</b> 4096 = 100.00% Refer to Chapter 13, <i>Understanding the Auto-tuning Procedure</i> , for more information.
168	<b>Flux Current</b>	Use <i>Flux Current</i> to specify the magnetizing current that produces rated flux in the motor in a per unit (percent representation). The auto-tune procedure measures the flux current during the quick motor tune portion of start up.	<b>Parameter number</b> 168 <b>File:group</b> Motor/Inverter:Motor Constants Autotune:Autotune Results <b>Parameter type</b> destination <b>Display</b> x.xx% <b>Factory default</b> 30.00% <b>Minimum value</b> 0.00% <b>Maximum value</b> 75.00% <b>Conversion</b> 4096 = 100.00% Refer to Chapter 13, <i>Understanding the Auto-tuning Procedure</i> , for more information.
169	<b>Slip Gain</b>	Use <i>Slip Gain</i> to fine tune the slip constant of the motor to improve speed regulation in encoderless mode.	<b>Parameter number</b> 169 <b>File:group</b> Motor/Inverter:Motor Constants Autotune:Autotune Results <b>Parameter type</b> destination <b>Display</b> x.x% <b>Factory default</b> 100.0% <b>Minimum value</b> 0.0% <b>Maximum value</b> 400.0% <b>Conversion</b> 1024 = 100.0% Refer to Chapter 9, <i>Applications</i> , for more information.



<b>170</b>	<b>Vd Max</b>	Use <i>Vd Max</i> to view the maximum D axis voltage allowed on the motor. The auto-tune routine calculates the value of <i>Vd Max</i> . You should not change this value. Vd is short for flux axis voltage.	<b>Parameter number</b>	170
			<b>File:group</b>	none
			<b>Parameter type</b>	destination
			<b>Display</b>	x.x volts
			<b>Factory default</b>	calculated
			<b>Minimum value</b>	0.0 volts
			<b>Maximum value</b>	468.8 volts
			<b>Conversion</b>	16 = 1.0

<b>171</b>	<b>Vq Max</b>	Use <i>Vq Max</i> to view the Q axis voltage at which the motor enters field weakening. The auto-tune routine calculates the value of <i>Vq Max</i> . You should not change this value. Vq is short for torque axis voltage.	<b>Parameter number</b>	171
			<b>File:group</b>	none
			<b>Parameter type</b>	destination
			<b>Display</b>	x.x volts
			<b>Factory default</b>	calculated
			<b>Minimum value</b>	0.0 volts
			<b>Maximum value</b>	468.8 volts
			<b>Conversion</b>	16 = 1.0

<b>172</b>	<b>Trans Dgn Config</b>	Use <i>Trans Dgn Config</i> to disable certain transistor diagnostic tests.  The bits are defined as follows:	<b>Parameter number</b>	172
			<b>File:group</b>	Autotune:Autotune Setup
			<b>Parameter type</b>	linkable destination
			<b>Display</b>	bits
			<b>Factory default</b>	00000000.00000000
			<b>Minimum value</b>	00000000.00000000
			<b>Maximum value</b>	00001111.11011111
			<b>Conversion</b>	1 = 1
			Refer to Chapter 13, <i>Understanding the Auto-tuning Procedure</i> , for more information.	

Bit	Disables:	Bit	Disables:	Bit	Disables:
0	<b>Cur Fdbk U</b> I feedback phase U offset	5	<b>Reserved</b> Leave 0.	9	<b>Trans V Lo</b> Power trans V lower for all tests
1	<b>Cur Fdbk W</b> I feedback phase W offset	6	<b>Trans U Up</b> Power trans U upper for all tests	10	<b>Trans W Up</b> Power trans W upper for all tests
2	<b>Short Trans</b> Shorted transistor tests	7	<b>Trans U Lo</b> Power trans U lower for all tests	11	<b>Trans W Lo</b> Power trans W lower for all tests
3	<b>Ground Fault</b> Ground fault tests	8	<b>Trans V Up</b> Power trans V upper for all tests	12 – 15	<b>Reserved</b> Leave 0.
4	<b>Open Tests</b> Open device tests				

<b>173</b>	<b>Autotune/Dgn Sel</b>	Use <i>Autotune/Dgn Sel</i> to select the drive diagnostic and commissioning test.  The bits are defined as follows:	<b>Parameter number</b>	173
			<b>File:group</b>	Autotune:Autotune Setup
			<b>Parameter type</b>	linkable destination
			<b>Display</b>	bits
			<b>Factory default</b>	00000000.00000000
			<b>Minimum value</b>	00000000.00000000
			<b>Maximum value</b>	00000000.00111111
			<b>Conversion</b>	1 = 1
			Refer to Chapter 13, <i>Understanding the Auto-tuning Procedure</i> , for more information.	

Bit	Selects:	Bit	Selects:	Bit	Selects:	Bit	Selects:
0	<b>Trans Diag</b> Inverter transistor diagnostics	2	<b>Lo Measure</b> Leakage inductance test	4	<b>Id Measure</b> Flux current measure	6 – 15	<b>Reserved</b> Leave 0.
1	<b>Mtr Phas Rot</b> Motor phase rotation test	3	<b>Rs Measure</b> Stator resistance tests	5	<b>Inertia</b> Inertia tests		

**174 Inverter Dgn1**

*Inverter Dgn1* shows the results of the transistor diagnostic tests. If any of the bits are set, then a problem with the associated test is indicated.

The bits are defined as follows:

Bit	Description
0	<b>Soft Fault</b> A software fault occurred.
1	<b>No Mtr/Bfuse</b> No motor connected or an open bus fuse.
2	<b>Short Ph U-W</b> Phase U and W shorted.
3	<b>Short Ph U-V</b> Phase U and V shorted.
4	<b>Short Ph V-W</b> Phase V and W shorted.
5	<b>Short Module</b> Shorted modules.
6	<b>Gnd Flt Mod</b> Ground fault.
7	<b>PriorTst Flt</b> Fault before shorted module ran.

<b>Parameter number</b>	174
<b>File:group</b>	Autotune:Autotune Status
<b>Parameter type</b>	source
<b>Display</b>	bits
<b>Factory default</b>	not applicable
<b>Minimum value</b>	00000000.00000000
<b>Maximum value</b>	00111111.11111111
<b>Conversion</b>	1 = 1
Refer to Chapter 13, <i>Understanding the Auto-tuning Procedure</i> , for more information.	

**175 Inverter Dgn2**

*Inverter Dgn2* shows the results of the transistor diagnostic tests. If any of the bits are set, then a problem with the associated test is indicated.

The bits are defined as follows:

Bit	Description	Bit	Description	Bit	Description
0	<b>U Up Short</b> Transistor U upper shorted	6	<b>U Offset</b> Current fdbk ph U offset too big	11	<b>V Lo Open</b> Transistor V lower open
1	<b>U Lo Short</b> Transistor U lower shorted	7	<b>W Offset</b> Current fdbk ph W offset too big	12	<b>W Up Open</b> Transistor W upper open
2	<b>V Up Short</b> Transistor V upper shorted	8	<b>U Up Open</b> Transistor U upper open	13	<b>W Lo Open</b> Transistor W lower open
3	<b>V Lo Short</b> Transistor V lower shorted	9	<b>U Lo Open</b> Transistor U lower open	14	<b>U Open</b> Current feedback phase U open
4	<b>W Up Short</b> Transistor W upper shorted	10	<b>V Up Open</b> Transistor V upper open	15	<b>W Open</b> Current feedback phase W open
5	<b>W Lo Short</b> Transistor W lower shorted				

<b>Parameter number</b>	175
<b>File:group</b>	Autotune:Autotune Status
<b>Parameter type</b>	source
<b>Display</b>	bits
<b>Factory default</b>	not applicable
<b>Minimum value</b>	00000000.00000000
<b>Maximum value</b>	11111111.11111111
<b>Conversion</b>	1 = 1
Refer to Chapter 13, <i>Understanding the Auto-tuning Procedure</i> , for more information.	

**176 Autotune Errors**

*Autotune Errors* shows the results of the auto-tune tests. The test results are divided into four categories: slip calculations, leakage inductance tests, resistance tests, and flux current tests. If a fault occurred during the auto-tune tests, the appropriate bit is set in *Autotune Errors*. If no bits are set, the drive passed all of the auto-tune tests.

The bits are defined as follows:

**Bit Description**

0	<b>Slip &lt;= 0</b> Slip is 0 or negative.
<b>Inductance Tests</b>	
1	<b>Ind- &gt; 0 Spd</b> Not at zero speed.
2	<b>Ind-Sign Err</b> Sign error or negative Lsigma.
3	<b>Ind- 0 Cur</b> Zero current.
4	<b>Ind-A/D Ovfl</b> A/D overflow at minimum gain.
5	<b>Ind-En Drop</b> Enable dropout.

**Bit Description**

<b>Resistance Tests</b>	
6	<b>Res- &gt; 0 Spd</b> Not at zero speed.
7	<b>Res-Sign Err</b> Sign error.
8	<b>Res- 0 Cur</b> Zero current.
9	<b>Res-SW Err</b> Software error.
10	<b>Res-En Drop</b> Enable dropout.

**Bit Description**

<b>Flux Current Tests</b>	
11	<b>Flx-Atune Lo</b> Auto-tune setpoint is too low.
12	<b>Flx-Flux &lt; 0</b> Flux less than zero.
13	<b>Flx-Cur&gt;MCur</b> Flux current > rated motor current.
14	<b>Flx-En Drop</b> Enable dropout.
15	<b>Flx-Hi Load</b> The load is too high.

<b>Parameter number</b>	176
<b>File:group</b>	Autotune:Autotune Status
<b>Parameter type</b>	source
<b>Display</b>	bits
<b>Factory default</b>	not applicable
<b>Minimum value</b>	00000000.00000000
<b>Maximum value</b>	11111111.11111111
<b>Conversion</b>	1 = 1
Refer to Chapter 13, <i>Understanding the Auto-tuning Procedure</i> , for more information.	

**177 Ki Freq Reg**

*Ki Freq Reg* contains the integral gain of the frequency regulator in encoderless mode. Do not change the value of this parameter.

<b>Parameter number</b>	177
<b>File:group</b>	none
<b>Parameter type</b>	destination
<b>Display</b>	x
<b>Factory default</b>	300
<b>Minimum value</b>	0
<b>Maximum value</b>	32767
<b>Conversion</b>	1 = 1

**178 Kp Freq Reg**

*Kp Freq Reg* contains the proportional gain of the frequency regulator in encoderless mode. Do not change the value of this parameter.

<b>Parameter number</b>	178
<b>File:group</b>	none
<b>Parameter type</b>	destination
<b>Display</b>	x
<b>Factory default</b>	800
<b>Minimum value</b>	0
<b>Maximum value</b>	32767
<b>Conversion</b>	1 = 1

**179 Kf Freq Reg**

*Kf Freq Reg* contains the feed-forward gain of the frequency regulator in encoderless mode. Do not change the value of this parameter.

<b>Parameter number</b>	179
<b>File:group</b>	none
<b>Parameter type</b>	destination
<b>Display</b>	x.x
<b>Factory default</b>	1.0
<b>Minimum value</b>	0.0
<b>Maximum value</b>	128.0
<b>Conversion</b>	256 = 1.0

<b>180</b>	<b>Freq Track Filtr</b> <i>Freq Track Filtr</i> contains the rotor frequency regulator filter in encoderless mode. Do not change the value of this parameter.	<b>Parameter number</b>	180
		<b>File:group</b>	none
		<b>Parameter type</b>	destination
		<b>Display</b>	x
		<b>Factory default</b>	5000
		<b>Minimum value</b>	0
		<b>Maximum value</b>	32767
		<b>Conversion</b>	1 = 1
<b>181</b>	<b>SP 2 Wire Enable<sup>1</sup></b> <i>SP 2 Wire Enable</i> lets you specify whether the specified SCANport device uses 2 wire or 3 wire control. When you are operating in 2 wire control, the start button acts like a jog.  1 <i>SP 2 Wire Enable</i> was added in Version 2.xx.	<b>Parameter number</b>	181
		<b>File:group</b>	Interface/Comm:SCANport Config
		<b>Parameter type</b>	destination
		<b>Display</b>	bits
		<b>Factory default</b>	00000000
		<b>Minimum value</b>	00000000
		<b>Maximum value</b>	11111110
		<b>Conversion</b>	1 = 1
	<b>Bit Description</b>	<b>Bit Description</b>	
	0 <b>Reserved</b> Leave 0.	4 <b>SP 4</b> Set to enable the device connected to SCANport 4 for 2 wire control.	
	1 <b>SP 1</b> Set to enable the device connected to SCANport 1 for 2 wire control.	5 <b>SP 5</b> Set to enable the device connected to SCANport 5 for 2 wire control.	
	2 <b>SP 2</b> Set to enable the device connected to SCANport 2 for 2 wire control.	6 <b>SP 6</b> Set to enable the device connected to SCANport 6 for 2 wire control.	
	3 <b>SP 3</b> Set to enable the device connected to SCANport 3 for 2 wire control.	7 <b>P197</b> Set to enable <i>Logic Cmd Input</i> (parameter 197) for 2 wire control.	
<b>182</b>	<b>An In1 Filter BW<sup>1</sup></b> Use <i>An In1 Filter BW</i> to use a low pass filter on the analog input 1. This filter adjusts the bandwidth to get better filtering. By using the low pass filter, you lose some bandwidth, but the value becomes more stable.  1 <i>An In1 Filter BW</i> was added in Version 2.xx.	<b>Parameter number</b>	182
		<b>File:group</b>	Interface/Comm:Analog Inputs
		<b>Parameter type</b>	linkable destination
		<b>Display</b>	x.x radians per second
		<b>Factory default</b>	0.0 radians per second
		<b>Minimum value</b>	0.0 radians per second
		<b>Maximum value</b>	200.0 radians per second
		<b>Conversion</b>	10 = 1
<b>183</b>	<b>An In2 Filter BW<sup>1</sup></b> Use <i>An In2 Filter BW</i> to use a low pass filter on the analog input 2. This filter adjusts the bandwidth to get better filtering. By using the low pass filter, you lose some bandwidth, but the value becomes more stable.  1 <i>An In1 Filter BW</i> was added in Version 2.xx.	<b>Parameter number</b>	183
		<b>File:group</b>	Interface/Comm:Analog Inputs
		<b>Parameter type</b>	linkable destination
		<b>Display</b>	x.x radians per second
		<b>Factory default</b>	0.0 radians per second
		<b>Minimum value</b>	0.0 radians per second
		<b>Maximum value</b>	200.0 radians per second
		<b>Conversion</b>	10 = 1
<b>184</b>	<b>mA In Filter BW<sup>1</sup></b> Use <i>mA In Filter BW</i> to use a low pass filter on the 4 – 20 mA input. This filter adjusts the bandwidth to get better filtering. By using the low pass filter, you lose some bandwidth, but the value becomes more stable.  1 <i>mA In Filter BW</i> was added in Version 2.xx.	<b>Parameter number</b>	184
		<b>File:group</b>	Interface/Comm:Analog Inputs
		<b>Parameter type</b>	linkable destination
		<b>Display</b>	x.x radians per second
		<b>Factory default</b>	0.0 radians per second
		<b>Minimum value</b>	0.0 radians per second
		<b>Maximum value</b>	200.0 radians per second
		<b>Conversion</b>	10 = 1

<b>185</b>	<b>Notch Filtr Freq<sup>1</sup></b>	<b>Parameter number</b>	185
		<b>File:group</b>	Control:Speed Feedback
	Use <i>Notch Filtr Freq</i> to set the center frequency for an optional 2-pole notch filter. To enable the notch filter, you need to set <i>Fdbk Filter Sel</i> (parameter 65) to 4.	<b>Parameter type</b>	linkable destination
		<b>Display</b>	x.x Hz
	1 <i>Notch Filtr Freq</i> was added in Version 2.xx.	<b>Factory default</b>	135.0 Hz
		<b>Minimum value</b>	5.0 Hz
		<b>Maximum value</b>	135.0 Hz
		<b>Conversion</b>	8 = 1
		Refer to the Torque Reference Overview in Appendix B, <i>Control Block Diagrams</i> , for more information about the notch filter.	
<b>186</b>	<b>Notch Filtr Q<sup>1</sup></b>	<b>Parameter number</b>	186
		<b>File:group</b>	Control:Speed Feedback
	Use <i>Notch Filtr Q</i> to set the quality factor, or Q, for the 2-pole notch filter. To enable the notch filter, you need to set <i>Fdbk Filter Sel</i> (parameter 65) to 4.	<b>Parameter type</b>	linkable destination
		<b>Display</b>	x
	1 <i>Notch Filtr Q</i> was added in Version 2.xx.	<b>Factory default</b>	50
		<b>Minimum value</b>	2
		<b>Maximum value</b>	500
		<b>Conversion</b>	1 = 1
		Refer to the Torque Reference Overview in Appendix B, <i>Control Block Diagrams</i> , for more information about the notch filter.	

<b>187 Relay Config 2<sup>1</sup></b>		<b>Parameter number</b>		187	
Use <i>Relay Config 2</i> to select the function of terminal 3 on either TB10 (for frames A1 – A4) or TB11 (for frames B – H) output.		<b>File:group</b>	Interface/Comm:Digital Config destination		
		<b>Parameter type</b>			
		<b>Display</b>	x		
		<b>Factory default</b>	33		
		<b>Minimum value</b>	0		
		<b>Maximum value</b>	36		
		<b>Conversion</b>	1 = 1		
1 <i>Relay Config 2</i> was added in Version 2.xx.					
<i>Relay Config 2</i> may be any one of the following values:					
<b>Value</b>	<b>Description</b>	<b>Value</b>	<b>Description</b>	<b>Value</b>	<b>Description</b>
0	<b>Disabled</b> The relay is disabled.	16	<b>Not Zero Spd</b> The motor is not at zero speed.	29	<b>Faulted</b> A fault has occurred.
1	<b>Run Ready</b> The drive is ready to run.	17	<b>Flux Ready</b> The motor is ready to be fluxed up.	30	<b>Not Faulted</b> A fault has not occurred.
2	<b>Not Run Rdy</b> The drive is not ready to run.	18	<b>Not Flux Rdy</b> The motor is not ready to be fluxed up.	31	<b>Warning</b> A warning has occurred.
3	<b>Running</b> Commanded speed is not zero.	19	<b>Flux Up</b> The drive feels the motor is fluxed up.	32	<b>Not Warning</b> A warning has not occurred.
4	<b>Not Running</b> Commanded speed is zero.	20	<b>Not Flux Up</b> The drive feels the motor is not fluxed up.	33	<b>Enable</b> Power is being applied to the motor.
5	<b>Stopping</b> The drive is stopping.	21	<b>Jogging</b> The motor is jogging.	34	<b>Not Enable</b> Power is not being applied to the motor.
6	<b>Not Stopping</b> The drive is not stopping.	22	<b>Not Jogging</b> The motor is not jogging.	35	<b>Function Val</b> True when the value of <i>Function Output 1</i> (par. 213) and/or the value of <i>Function Output 2</i> (par. 214) are zero.
7	<b>Stopped</b> The drive is stopped.	23	<b>At Limit</b> The motor is at the limit shown in <i>Torque Limit Sts</i> (parameter 87)	36	<b>Not Function Val</b> True when the values of both <i>Function Output 1</i> (par. 213) and <i>Function Output 2</i> (par. 214) are zero.
8	<b>Not Stopped</b> The drive is not stopped.	24	<b>Not At Lim</b> The motor is not at the limit shown in <i>Torque Limit Sts</i> (parameter 87).	37	<b>Function T/F</b> True when timer or logical state of add/sub or mult/div is true based on the selected function block.
9	<b>Accelerating</b> The motor is accelerating.	25	<b>&gt;= Speed</b> The motor speed is greater than or equal to <i>Relay Setpoint 2</i> (parameter 188).	38	<b>Function T/F</b> False when timer or logical state of add/sub or mult/div is false based on the selected function block.
10	<b>Not Accel</b> The motor is not accelerating.	26	<b>&lt; Speed</b> The motor speed is less than <i>Relay Setpoint 2</i> (parameter 188).		
11	<b>Decelerating</b> The motor is decelerating.	27	<b>&gt;=Current</b> The motor current is greater than or equal to <i>Relay Setpoint 2</i> (parameter 188).		
12	<b>Not Decel</b> The motor is not decelerating.	28	<b>&lt;Current</b> The motor current is less than <i>Relay Setpoint 2</i> (parameter 188).		
13	<b>At Set Speed</b> The motor is at the requested speed.				
14	<b>Not Set Sp</b> The motor is not at the requested speed.				
15	<b>At Zero Spd</b> The motor is at zero speed.				

<b>188 Relay Setpoint 2<sup>1</sup></b>		<b>Parameter number</b>		188
Use <i>Relay Setpoint 2</i> to specify the setpoint threshold for either speed or current. <i>Relay Setpoint 2</i> is only active if <i>Relay Config 2</i> (parameter 187) is set to a value of 25, 26, 27, or 28.		<b>File:group</b>	Interface/Comm:Digital Config linkable destination	
		<b>Parameter type</b>		
		<b>Display</b>	±x.x%	
		<b>Factory default</b>	+0.0%	
		<b>Minimum value</b>	-800.0%	
		<b>Maximum value</b>	+800.0%	
		<b>Conversion</b>	4096 = 100.0%	
1 <i>Relay Setpoint 2</i> was added in Version 2.xx.				

189

**Relay Config 3<sup>1</sup>**

Use *Relay Config 3* to select the function of terminals 4, 5, and 6 on either TB10 (for frames A1 – A4) or TB11 (for frames B – H) output.

1 *Relay Config 3* was added in Version 2.xx.

*Relay Config 3* may be any one of the following values:

Value	Description	Value	Description	Value	Description
0	<b>Disabled</b> The relay is disabled.	16	<b>Not Zero Spd</b> The motor is not at zero speed.	29	<b>Faulted</b> A fault has occurred.
1	<b>Run Ready</b> The drive is ready to run.	17	<b>Flux Ready</b> The motor is ready to be fluxed up.	30	<b>Not Faulted</b> A fault has not occurred.
2	<b>Not Run Rdy</b> The drive is not ready to run.	18	<b>Not Flux Rdy</b> The motor is not ready to be fluxed up.	31	<b>Warning</b> A warning has occurred.
3	<b>Running</b> Commanded speed is not zero.	19	<b>Flux Up</b> The drive feels the motor is fluxed up.	32	<b>Not Warning</b> A warning has not occurred.
4	<b>Not Running</b> Commanded speed is zero.	20	<b>Not Flux Up</b> The drive feels the motor is not fluxed up.	33	<b>Enable</b> Power is being applied to the motor.
5	<b>Stopping</b> The drive is stopping.	21	<b>Jogging</b> The motor is jogging.	34	<b>Not Enable</b> Power is not being applied to the motor.
6	<b>Not Stopping</b> The drive is not stopping.	22	<b>Not Jogging</b> The motor is not jogging.	35	<b>Function Val</b> True when the value of <i>Function Output 1</i> (par. 213) and/or the value of <i>Function Output 2</i> (par. 214) are zero.
7	<b>Stopped</b> The drive is stopped.	23	<b>At Limit</b> The motor is at the limit shown in <i>Torque Limit Sts</i> (parameter 87)	36	<b>Not Function Val</b> True when the values of both <i>Function Output 1</i> (par. 213) and <i>Function Output 2</i> (par. 214) are zero.
8	<b>Not Stopped</b> The drive is not stopped.	24	<b>Not At Lim</b> The motor is not at the limit shown in <i>Torque Limit Sts</i> (parameter 87).	37	<b>Function T/F</b> True when timer or logical state of add/sub or mult/div is true based on the selected function block.
9	<b>Accelerating</b> The motor is accelerating.	25	<b>&gt;= Speed</b> The motor speed is greater than or equal to <i>Relay Setpoint 3</i> (parameter 190).	38	<b>Function T/F</b> False when timer or logical state of add/sub or mult/div is false based on the selected function block.
10	<b>Not Accel</b> The motor is not accelerating.	26	<b>&lt; Speed</b> The motor speed is less than <i>Relay Setpoint 3</i> (parameter 190).		
11	<b>Decelerating</b> The motor is decelerating.	27	<b>&gt;=Current</b> The motor current is greater than or equal to <i>Relay Setpoint 3</i> (parameter 190).		
12	<b>Not Decel</b> The motor is not decelerating.	28	<b>&lt;Current</b> The motor current is less than <i>Relay Setpoint 3</i> (parameter 190).		
13	<b>At Set Speed</b> The motor is at the requested speed.				
14	<b>Not Set Sp</b> The motor is not at the requested speed.				
15	<b>At Zero Spd</b> The motor is at zero speed.				

<b>Parameter number</b>	189
<b>File:group</b>	Interface/Comm:Digital Config
<b>Parameter type</b>	linkable destination
<b>Display</b>	x
<b>Factory default</b>	30
<b>Minimum value</b>	0
<b>Maximum value</b>	36
<b>Conversion</b>	1 = 1

190

**Relay Setpoint 3<sup>1</sup>**

*Relay Setpoint 3* lets you specify the setpoint threshold for either speed or current. *Relay Setpoint 3* is only active if *Relay Config 3* (parameter 189) is set to a value of 25, 26, 27, or 28.

1 *Relay Setpoint 3* was added in Version 2.xx.

<b>Parameter number</b>	190
<b>File:group</b>	Interface/Comm:Digital Config
<b>Parameter type</b>	linkable destination
<b>Display</b>	±x.x%
<b>Factory default</b>	+0.0%
<b>Minimum value</b>	-800.0%
<b>Maximum value</b>	+800.0%
<b>Conversion</b>	4096 = 100.0%

<b>191 Relay Config 4<sup>1</sup></b>		<b>Parameter number</b>	
Use <i>Relay Config 4</i> to select the function of terminals 7, 8, and 9 of either TB10 (for frames A1 – A4) or TB11 (for frames B – H) output.		<b>File:group</b>	Interface/Comm:Digital Config destination
1 <i>Relay Config 4</i> was added in Version 2.xx.		<b>Parameter type</b>	x
		<b>Display</b>	32
		<b>Factory default</b>	0
		<b>Minimum value</b>	36
		<b>Maximum value</b>	1 = 1
		<b>Conversion</b>	
<i>Relay Config 4</i> may be any one of the following values:			
<b>Value</b>	<b>Description</b>	<b>Value</b>	<b>Description</b>
0	<b>Disabled</b> The relay is disabled.	16	<b>Not Zero Spd</b> The motor is not at zero speed.
1	<b>Run Ready</b> The drive is ready to run.	17	<b>Flux Ready</b> The motor is ready to be fluxed up.
2	<b>Not Run Rdy</b> The drive is not ready to run.	18	<b>Not Flux Rdy</b> The motor is not ready to be fluxed up.
3	<b>Running</b> Commanded speed is not zero.	19	<b>Flux Up</b> The drive feels the motor is fluxed up.
4	<b>Not Running</b> Commanded speed is zero.	20	<b>Not Flux Up</b> The drive feels the motor is not fluxed up.
5	<b>Stopping</b> The drive is stopping.	21	<b>Jogging</b> The motor is jogging.
6	<b>Not Stopping</b> The drive is not stopping.	22	<b>Not Jogging</b> The motor is not jogging.
7	<b>Stopped</b> The drive is stopped.	23	<b>At Limit</b> The motor is at the limit shown in <i>Torque Limit Sts</i> (parameter 87)
8	<b>Not Stopped</b> The drive is not stopped.	24	<b>Not At Lim</b> The motor is not at the limit shown in <i>Torque Limit Sts</i> (parameter 87).
9	<b>Accelerating</b> The motor is accelerating.	25	<b>&gt;= Speed</b> The motor speed is greater than or equal to <i>Relay Setpoint 4</i> (parameter 192).
10	<b>Not Accel</b> The motor is not accelerating.	26	<b>&lt; Speed</b> The motor speed is less than <i>Relay Setpoint 4</i> (parameter 192).
11	<b>Decelerating</b> The motor is decelerating.	27	<b>&gt;= Current</b> The motor current is greater than or equal to <i>Relay Setpoint 4</i> (parameter 192).
12	<b>Not Decel</b> The motor is not decelerating.	28	<b>&lt; Current</b> The motor current is less than <i>Relay Setpoint 4</i> (parameter 192).
13	<b>At Set Speed</b> The motor is at the requested speed.	29	<b>Faulted</b> A fault has occurred.
14	<b>Not Set Sp</b> The motor is not at the requested speed.	30	<b>Not Faulted</b> A fault has not occurred.
15	<b>At Zero Spd</b> The motor is at zero speed.	31	<b>Warning</b> A warning has occurred.
		32	<b>Not Warning</b> A warning has not occurred.
		33	<b>Enable</b> Power is being applied to the motor.
		34	<b>Not Enable</b> Power is not being applied to the motor.
		35	<b>Function Val</b> True when the value of <i>Function Output 1</i> (par. 213) and/or the value of <i>Function Output 2</i> (par. 214) are zero.
		36	<b>Not Function Val</b> True when the values of both <i>Function Output 1</i> (par. 213) and <i>Function Output 2</i> (par. 214) are zero.
		37	<b>Function T/F</b> True when timer or logical state of add/sub or mult/div is true based on the selected function block.
		38	<b>Function T/F</b> False when timer or logical state of add/sub or mult/div is false based on the selected function block.
		39	<b>@ Profile Position</b>

<b>192 Relay Setpoint 4<sup>1</sup></b>		<b>Parameter number</b>	
Use <i>Relay Setpoint 4</i> to specify the setpoint threshold for either speed or current. <i>Relay Setpoint 4</i> is only active if <i>Relay Config 4</i> (parameter 191) is set to a value of 25, 26, 27, or 28.		<b>File:group</b>	Interface/Comm:Digital Config linkable destination
1 <i>Relay Config 4</i> was added in Version 2.xx.		<b>Parameter type</b>	±x.x%
		<b>Display</b>	+0.0%
		<b>Factory default</b>	-800.0%
		<b>Minimum value</b>	+800.0%
		<b>Maximum value</b>	4096 = 100.0%
		<b>Conversion</b>	



<b>193</b>	<b>Start Dwell Spd<sup>1</sup></b>	<p><b>Parameter number</b> 193</p> <p><b>File:group</b> Control:Drive Logic Sel</p> <p><b>Parameter type</b> linkable destination</p> <p><b>Display</b> ±x.x rpm</p> <p><b>Factory default</b> +0.0 rpm</p> <p><b>Minimum value</b> -0.1 x base motor speed</p> <p><b>Maximum value</b> +0.1 x base motor speed</p> <p><b>Conversion</b> 4096 = base motor speed</p> <p>Refer to the Speed Reference Selection Overview section in Appendix B, <i>Control Block Diagrams</i>, for more information.</p>						
	<p><i>Start Dwell Spd</i> lets you set the speed that the drive immediately outputs when a start command is issued. No acceleration ramp is used. You must enter a time value in <i>Start Dwell Time</i> (parameter 194).</p> <p>1 <i>Start Dwell Spd</i> was added in Version 2.xx.</p>							
<b>194</b>	<b>Start Dwell Time<sup>1</sup></b>	<p><b>Parameter number</b> 194</p> <p><b>File:group</b> Control:Drive Logic Sel</p> <p><b>Parameter type</b> linkable destination</p> <p><b>Display</b> x.x seconds</p> <p><b>Factory default</b> 0.0 seconds</p> <p><b>Minimum value</b> 0.0 seconds</p> <p><b>Maximum value</b> 10.0 seconds</p> <p><b>Conversion</b> seconds x 10</p> <p>Refer to the Speed Reference Selection Overview section in Appendix B, <i>Control Block Diagrams</i>, for more information.</p>						
	<p><i>Start Dwell Time</i> lets you specify how long you want the drive to continue using <i>Start Dwell Spd</i> (parameter 193) before ramping to whichever speed reference you have selected (speed references 1 through 7).</p> <p>1 <i>Start Dwell Time</i> was added in Version 2.xx.</p>							
<b>195</b>	<b>Max Mtr Current<sup>1</sup></b>	<p><b>Parameter number</b> 195</p> <p><b>File:group</b> Control:Control Limits</p> <p><b>Application:</b>200/400% Mtr Cur destination</p> <p><b>Parameter type</b> destination</p> <p><b>Display</b> x</p> <p><b>Factory default</b> 0</p> <p><b>Minimum value</b> 0</p> <p><b>Maximum value</b> 1</p> <p><b>Conversion</b> 1 = 1</p> <p>Refer to the Using Up to 400% Motor Current section of Chapter 9, <i>Applications</i>.</p>						
	<p>Use <i>Max Mtr Current</i> to increase the maximum motor current from 200% to 400% if you are using a drive that is significantly larger than your motor.</p> <table border="1" data-bbox="289 1029 876 1144"> <thead> <tr> <th>Choose:</th> <th>To Select:</th> </tr> </thead> <tbody> <tr> <td>0</td> <td>200% maximum motor current</td> </tr> <tr> <td>1</td> <td>400% maximum motor current</td> </tr> </tbody> </table> <p>Regardless of your selection, the drive limits current to 150% of the rated inverter current.</p> <p>1 <i>Max Mtr Current</i> was added in Version 2.xx.</p>	Choose:	To Select:	0	200% maximum motor current	1	400% maximum motor current	
Choose:	To Select:							
0	200% maximum motor current							
1	400% maximum motor current							

**196 Drive/Inv Sts 2<sup>1</sup>**

Use *Drive/Inv Sts 2* to view the status/conditions within the drive. When a bit is set (1), the corresponding condition in the drive is true.

1 *Drive/Inv Sts 2* was added in Version 2.xx.

When set, the bits are defined as the following:

Bit	Description	Bit	Description
0	<b>Flux Ready</b> The motor is ready to be fluxed up.	6	<b>Searching</b> Flying start is syncing with motor.
1	<b>Flux Up</b> The motor is fluxed up.	7	<b>Enc TrimLoss</b> Indicates encoder loss when using Encoder switchover mode
2	<b>DC Braking</b> DC braking is currently being used.	8	<b>At Limit</b> The motor is at the At Limit set point.
3	<b>Reserved</b> Leave 0.	9	<b>Func Output</b> <i>Function Output 1</i> (parameter 213) and/or <i>Function Output 2</i> (parameter 214) is non-zero.
4	<b>Bus Ridethru</b> The drive is in a bus ridethrough condition.	10 – 11	<b>Reserved</b> Leave 0.
5	<b>Jogging</b> The drive is jogging.		

<b>Parameter number</b>	196
<b>File:group</b>	Monitor:Drive/Inv Status
<b>Parameter type</b>	source
<b>Display</b>	bits
<b>Factory default</b>	not applicable
<b>Minimum value</b>	00000000.00000000
<b>Maximum value</b>	11111111.11111111
<b>Conversion</b>	1 = 1

**197 Logic Cmd Input<sup>1</sup>**

Use *Logic Cmd Input* to change the logic evaluation block. The bits that you change here are reflected in *Logic Input Sts* (parameter 14).

1 *Logic Cmd Input* was added in Version 2.xx.

The bits are defined as follows:

Bit	Description	Bit	Description	Bit	Description
0	<b>Normal Stop</b> A ramp stop is selected.	5	<b>Reverse</b> A reverse was commanded.	10	<b>Flux Enable</b> Flux is enabled.
1	<b>Start</b> A start is in progress.	6	<b>Jog 2</b> A jog 2 is in progress.	11	<b>Process Trim</b> Process trim is enabled.
2	<b>Jog 1</b> A jog 1 is in progress.	7	<b>Cur Lim Stop</b> A current limit stop is selected.	12	<b>Speed Ref A</b>
3	<b>Clear Fault</b> A clear fault is in progress.	8	<b>Coast Stop</b> A coast stop is selected.	13	<b>Speed Ref B</b>
4	<b>Forward</b> A forward was commanded.	9	<b>Spd Ramp Dis</b> Ramps are disabled.	14	<b>Speed Ref C</b>
				15	<b>Reset Drive</b> The drive has been commanded to reset.

<b>Parameter number</b>	197
<b>File:group</b>	none
<b>Parameter type</b>	linkable destination
<b>Display</b>	bits
<b>Factory default</b>	00000000.00000000
<b>Minimum value</b>	00000000.00000000
<b>Maximum value</b>	11111111.11111111
<b>Conversion</b>	1 = 1

	C	B	A	
0 0 0				No Charge
0 0 1				Speed Ref 1
0 1 0				Speed Ref 2
0 1 1				Speed Ref 3
1 0 0				Speed Ref 4
1 0 1				Speed Ref 5
1 1 0				Speed Ref 6
1 1 1				Speed Ref 7

<b>198</b>	<b>Function In1<sup>1</sup></b>	<p>Use <i>Function In1</i> to provide input into the function block that is provided with the 1336 IMPACT drive. You can choose to either evaluate the input value or pass the value directly to the function block.</p> <p>To evaluate <i>Function In1</i>, you need to also use <i>Func 1 Mask/Val</i> (parameter 199) and <i>Func 1 Eval Sel</i> (parameter 200).</p> <p>To pass the value directly to the function block, enter a value of 0 into <i>Func 1 Eval Sel</i>.</p> <p><sup>1</sup> <i>Function In1</i> was added in Version 2.xx.</p>	<b>Parameter number</b>	198
			<b>File:group</b>	Application:Prog Function
			<b>Parameter type</b>	linkable destination
			<b>Conversion</b>	1 = 1
			If <i>Func 1 Eval Sel</i> (parameter 200) is 0 or 6 – 11, then:	
			<b>Display</b>	±x
			<b>Factory default</b>	0
			<b>Minimum value</b>	-32767
			<b>Maximum value</b>	+32767
			If <i>Func 1 Eval Sel</i> (parameter 200) is 1 – 5, then:	
			<b>Display</b>	bits
			<b>Factory default</b>	00000000.00000000
			<b>Minimum value</b>	00000000.00000000
<b>Maximum value</b>	11111111.11111111			
If <i>Func 1 Eval Sel</i> (parameter 200) is 12 – 15, then:				
<b>Display</b>	x			
<b>Factory default</b>	0			
<b>Minimum value</b>	0			
<b>Maximum value</b>	65535			
Refer to Chapter 10, <i>Using the Function Block</i> , for more information.				

<b>199</b>	<b>Func 1 Mask/Val<sup>1</sup></b>	<p>Use <i>Func 1 Mask/Val</i> to enter a mask or value to compare <i>Function In1</i> (parameter 198) to, according to the value you select in <i>Func 1 Eval Sel</i> (parameter 200).</p> <p><sup>1</sup> <i>Func 1 Mask/Val</i> was added in Version 2.xx.</p>	<b>Parameter number</b>	199
			<b>File:group</b>	Application:Prog Function
			<b>Parameter type</b>	linkable destination
			<b>Conversion</b>	1 = 1
			If <i>Func 1 Eval Sel</i> (parameter 200) is 0 or 6 – 11, then:	
			<b>Display</b>	±x
			<b>Factory default</b>	-1
			<b>Minimum value</b>	-32767
			<b>Maximum value</b>	+32767
			If <i>Func 1 Eval Sel</i> (parameter 200) is 1 – 5, then:	
			<b>Display</b>	bits
			<b>Factory default</b>	11111111.11111111
			<b>Minimum value</b>	00000000.00000000
<b>Maximum value</b>	11111111.11111111			
If <i>Func 1 Eval Sel</i> (parameter 200) is 12 – 15, then:				
<b>Display</b>	x			
<b>Factory default</b>	65535			
<b>Minimum value</b>	0			
<b>Maximum value</b>	65535			
Refer to Chapter 10, <i>Using the Function Block</i> , for more information.				

<b>200</b>	<b>Func 1 Eval Sel<sup>1</sup></b>	<i>Func 1 Eval Sel</i> lets you choose how you want to evaluate <i>Function In1</i> (parameter 198).	<b>Parameter number</b> 200
		1 <i>Func 1 Eval Sel</i> was added in Version 2.xx.	<b>File:group</b> Application:Prog Function <b>Parameter type</b> linkable destination <b>Display</b> x <b>Factory default</b> 0 <b>Minimum value</b> 0 <b>Maximum value</b> 17 <b>Conversion</b> 1 = 1

Refer to Chapter 10, *Using the Function Block*, for more information.

Value	Description	Value	Description	Value	Description
0	<b>None</b> Pass the value directly on to the function block.	6	<b>I=V</b> Check to see if <i>Function In1</i> is equal to <i>Func 1 Mask/Val</i> .	12	<b>Unsign I&lt;V</b> Check to see if the unsigned value of <i>Function In1</i> is less than the value of <i>Func 1 Mask/Val</i> .
1	<b>Mask</b> Mask specific bits.	7	<b>I Not = V</b> Check to see if <i>Function In1</i> is not equal to <i>Func 1 Mask/Val</i> .	13	<b>Unsign I&lt;=V</b> Check to see if the unsigned value of <i>Function In1</i> is less than or equal to the value of <i>Func 1 Mask/Val</i> .
2	<b>All Bits On</b> Check to make sure that all bits that are set (on) in <i>Func 1 Mask/Val</i> (parameter 199) are set in <i>Function In1</i> (parameter 198).	8	<b>Signed I&lt;V</b> Check to see if the signed value of <i>Function In1</i> is less than the value of <i>Func 1 Mask/Val</i> .	14	<b>Unsign I&gt;V</b> Check to see if the unsigned value of <i>Function In1</i> is greater than the value of <i>Func 1 Mask/Val</i> .
3	<b>All Bits Off</b> Check to make sure that all bits that are set in <i>Func 1 Mask/Val</i> are clear in <i>Function In1</i> .	9	<b>Signed I&lt;=V</b> Check to see if the signed value of <i>Function In1</i> is less than or equal to the value of <i>Func 1 Mask/Val</i> .	15	<b>Unsign I&gt;=V</b> Check to see if the unsigned value of <i>Function In1</i> is greater than or equal to the value of <i>Func 1 Mask/Val</i> .
4	<b>Any Bit On</b> Check to make sure that at least one of the bits that are set in <i>Func 1 Mask/Val</i> is set in <i>Function In1</i> .	10	<b>Signed I&gt;V</b> Check to see if the signed value of <i>Function In1</i> is greater than the value of <i>Func 1 Mask/Val</i> .	16	<b>Invert</b> Pass the opposite value on to the function block
5	<b>Any Bit Off</b> Check to make sure that at least one of the bits that are set in <i>Func 1 Mask/Val</i> is clear in <i>Function In1</i> .	11	<b>Signed I&gt;=V</b> Check to see if the signed value of <i>Function In1</i> is greater than or equal to the value of <i>Func 1 Mask/Val</i> .	17	<b>Absolute</b> Pass a positive value on to the function block.

<b>201</b>	<b>Function In2<sup>1</sup></b>	Use <i>Function In2</i> to provide input into the function block that is provided with the 1336 IMPACT drive. You can choose to either evaluate <i>Function In2</i> or pass the value directly to the function block.	<b>Parameter number</b> 201
		To evaluate <i>Function In2</i> , you need to also use <i>Func 2 Mask/Val</i> (parameter 202) and <i>Func 2 Eval Sel</i> (parameter 203).	<b>File:group</b> Application:Prog Function <b>Parameter type</b> linkable destination <b>Conversion</b> 1 = 1
		To pass the value directly to the function block, enter a value of 0 into <i>Func 2 Eval Sel</i> .	<b>Display</b> ±x
		1 <i>Function In2</i> was added in Version 2.xx.	<b>Factory default</b> 0 <b>Minimum value</b> -32767 <b>Maximum value</b> +32767
			If <i>Func 2 Eval Sel</i> (parameter 203) is 0 or 6 – 11, then:
			<b>Display</b> bits
			<b>Factory default</b> 00000000.00000000 <b>Minimum value</b> 00000000.00000000 <b>Maximum value</b> 11111111.11111111
			If <i>Func 2 Eval Sel</i> (parameter 203) is 12 – 15, then:
			<b>Display</b> x <b>Factory default</b> 0 <b>Minimum value</b> 0 <b>Maximum value</b> 65535

Refer to Chapter 10, *Using the Function Block*, for more information.

<b>202</b>	<b>Func 2 Mask/Val<sup>1</sup></b>	<p>Use <i>Func 2 Mask/Val</i> to enter a mask or value to compare <i>Function In2</i> (parameter 201) to, according to the value you select in <i>Func 2 Eval Sel</i> (parameter 203).</p> <p>1 <i>Func 2 Mask/Val</i> was added in Version 2.xx.</p>	<b>Parameter number</b>	202
			<b>File:group</b>	Application:Prog Function
			<b>Parameter type</b>	linkable destination
			<b>Conversion</b>	1 = 1
			If <i>Func 2 Eval Sel</i> (parameter 203) is 0 or 6 – 11, then:	
			<b>Display</b>	±x
			<b>Factory default</b>	-1
			<b>Minimum value</b>	-32767
			<b>Maximum value</b>	+32767
			If <i>Func 2 Eval Sel</i> (parameter 203) is 1 – 5, then:	
			<b>Display</b>	bits
			<b>Factory default</b>	11111111.11111111
			<b>Minimum value</b>	00000000.00000000
			<b>Maximum value</b>	11111111.11111111
			If <i>Func 2 Eval Sel</i> (parameter 203) is 12 – 15, then:	
			<b>Display</b>	x
			<b>Factory default</b>	65535
			<b>Minimum value</b>	0
			<b>Maximum value</b>	65535
			Refer to Chapter 10, <i>Using the Function Block</i> , for more information.	

<b>203</b>	<b>Func 2 Eval Sel<sup>1</sup></b>	<p><i>Func 2 Eval Sel</i> lets you choose how you want to evaluate <i>Function In2</i> (parameter 201).</p> <p>1 <i>Func 2 Eval Sel</i> was added in Version 2.xx.</p>	<b>Parameter number</b>	203
			<b>File:group</b>	Application:Prog Function
			<b>Parameter type</b>	destination
			<b>Display</b>	x
			<b>Factory default</b>	0
			<b>Minimum value</b>	0
			<b>Maximum value</b>	17
			<b>Conversion</b>	1 = 1
			Refer to Chapter 10, <i>Using the Function Block</i> , for more information.	

Value	Description	Value	Description	Value	Description
0	<b>None</b> Pass the value directly on to the function block.	6	<b>I=V</b> Check to see if <i>Function In2</i> is equal to <i>Func 2 Mask/Val</i> .	12	<b>Unsign I&lt;V</b> Check to see if the unsigned value of <i>Function In2</i> is less than the value of <i>Func 2 Mask/Val</i> .
1	<b>Mask</b> Mask specific bits.	7	<b>I Not = V</b> Check to see if <i>Function In2</i> is not equal to <i>Func 2 Mask/Val</i> .	13	<b>Unsign I&lt;=V</b> Check to see if the unsigned value of <i>Function In2</i> is less than or equal to the value of <i>Func 2 Mask/Val</i> .
2	<b>All Bits On</b> Check to make sure that all bits that are set (on) in <i>Func 2 Mask/Val</i> (parameter 202) are set in <i>Function In2</i> (parameter 201).	8	<b>Signed I&lt;V</b> Check to see if the signed value of <i>Function In2</i> is less than the value of <i>Func 2 Mask/Val</i> .	14	<b>Unsign I&gt;V</b> Check to see if the unsigned value of <i>Function In2</i> is greater than the value of <i>Func 2 Mask/Val</i> .
3	<b>All Bits Off</b> Check to make sure that all bits that are set in <i>Func 2 Mask/Val</i> are clear in <i>Function In2</i> .	9	<b>Signed I&lt;=V</b> Check to see if the signed value of <i>Function In2</i> is less than or equal to the value of <i>Func 2 Mask/Val</i> .	15	<b>Unsign I&gt;=V</b> Check to see if the unsigned value of <i>Function In2</i> is greater than or equal to the value of <i>Func 2 Mask/Val</i> .
4	<b>Any Bit On</b> Check to make sure that at least one of the bits that are set in <i>Func 2 Mask/Val</i> is set in <i>Function In2</i> .	10	<b>Signed I&gt;V</b> Check to see if the signed value of <i>Function In2</i> is greater than the value of <i>Func 2 Mask/Val</i> .	16	<b>Invert</b> Pass the opposite value on to the function block
5	<b>Any Bit Off</b> Check to make sure that at least one of the bits that are set in <i>Func 2 Mask/Val</i> is clear in <i>Function In2</i> .	11	<b>Signed I&gt;=V</b> Check to see if the signed value of <i>Function In2</i> is greater than or equal to the value of <i>Func 2 Mask/Val</i> .	17	<b>Absolute</b> Pass a positive value on to the function block.

<b>204</b>	<b>Function In3<sup>1</sup></b>	<p>Use <i>Function In3</i> to provide input into the function block that is provided with the 1336 IMPACT drive. You can choose to either evaluate the input value or pass the value directly to the function block.</p> <p>To evaluate <i>Function In3</i>, you need to also use <i>Func 3 Mask/Val</i> (parameter 205) and <i>Func 3 Eval Sel</i> (parameter 206).</p> <p>To pass the value directly to the function block, enter a value of 0 into <i>Func 3 Eval Sel</i>.</p> <p><sup>1</sup> <i>Function In3</i> was added in Version 2.xx.</p>	<b>Parameter number</b>	204
			<b>File:group</b>	Application:Prog Function
			<b>Parameter type</b>	linkable destination
			<b>Conversion</b>	1 = 1
			If <i>Func 3 Eval Sel</i> (parameter 206) is 0 or 6 – 11, then:	
			<b>Display</b>	±x
			<b>Factory default</b>	0
			<b>Minimum value</b>	-32767
			<b>Maximum value</b>	+32767
			If <i>Func 3 Eval Sel</i> (parameter 206) is 1 – 5, then:	
			<b>Display</b>	bits
			<b>Factory default</b>	00000000.00000000
			<b>Minimum value</b>	00000000.00000000
			<b>Maximum value</b>	11111111.11111111
			If <i>Func 3 Eval Sel</i> (parameter 206) is 12 – 15, then:	
			<b>Display</b>	x
			<b>Factory default</b>	0
			<b>Minimum value</b>	0
			<b>Maximum value</b>	65535
			Refer to Chapter 10, <i>Using the Function Block</i> , for more information.	

<b>205</b>	<b>Func 3 Mask/Val<sup>1</sup></b>	<p>Use <i>Func 3 Mask/Val</i> to enter a mask or value to compare <i>Function In3</i> (parameter 204) to, according to the value you select in <i>Func 3 Eval Sel</i> (parameter 206).</p> <p><sup>1</sup> <i>Func 3 Mask/Val</i> was added in Version 2.xx.</p>	<b>Parameter number</b>	205
			<b>File:group</b>	Application:Prog Function
			<b>Parameter type</b>	linkable destination
			<b>Conversion</b>	1 = 1
			If <i>Func 3 Eval Sel</i> (parameter 206) is 0 or 6 – 11, then:	
			<b>Display</b>	±x
			<b>Factory default</b>	-1
			<b>Minimum value</b>	-32767
			<b>Maximum value</b>	+32767
			If <i>Func 3 Eval Sel</i> (parameter 206) is 1 – 5, then:	
			<b>Display</b>	bits
			<b>Factory default</b>	11111111.11111111
			<b>Minimum value</b>	00000000.00000000
			<b>Maximum value</b>	11111111.11111111
			If <i>Func 3 Eval Sel</i> (parameter 206) is 12 – 15, then:	
			<b>Display</b>	x
			<b>Factory default</b>	65535
			<b>Minimum value</b>	0
			<b>Maximum value</b>	65535
			Refer to Chapter 10, <i>Using the Function Block</i> , for more information.	

<b>206</b>	<b>Func3 Eval Sel<sup>1</sup></b>	<p><i>Func3 Eval Sel</i> lets you choose how you want to evaluate <i>Function In3</i> (parameter 204).</p> <p>1 <i>Func3 Eval Sel</i> was added in Version 2.xx.</p>	<b>Parameter number</b>	206	
			<b>File:group</b>	Application:Prog Function destination	
			<b>Parameter type</b>		
			<b>Display</b>	x	
			<b>Factory default</b>	0	
			<b>Minimum value</b>	0	
			<b>Maximum value</b>	17	
			<b>Conversion</b>	1 = 1	
			Refer to Chapter 10, <i>Using the Function Block</i> , for more information.		
<b>Value</b>	<b>Description</b>	<b>Value</b>	<b>Description</b>	<b>Value</b>	<b>Description</b>
0	<b>None</b> Pass the value directly on to the function block.	6	<b>I=V</b> Check to see if <i>Function In3</i> is equal to <i>Func3 Mask/Val</i> .	12	<b>Unsign I&lt;V</b> Check to see if the unsigned value of <i>Function In3</i> is less than the value of <i>Func3 Mask/Val</i> .
1	<b>Mask</b> Mask specific bits.	7	<b>I Not = V</b> Check to see if <i>Function In3</i> is not equal to <i>Func3 Mask/Val</i> .	13	<b>Unsign I&lt;=V</b> Check to see if the unsigned value of <i>Function In3</i> is less than or equal to the value of <i>Func3 Mask/Val</i> .
2	<b>All Bits On</b> Check to make sure that all bits that are set (on) in <i>Func3 Mask/Val</i> (parameter 205) are set in <i>Function In3</i> (parameter 204).	8	<b>Signed I&lt;V</b> Check to see if the signed value of <i>Function In3</i> is less than the value of <i>Func3 Mask/Val</i> .	14	<b>Unsign I&gt;V</b> Check to see if the unsigned value of <i>Function In3</i> is greater than the value of <i>Func3 Mask/Val</i> .
3	<b>All Bits Off</b> Check to make sure that all bits that are set in <i>Func3 Mask/Val</i> are clear in <i>Function In3</i> .	9	<b>Signed I&lt;=V</b> Check to see if the signed value of <i>Function In3</i> is less than or equal to the value of <i>Func3 Mask/Val</i> .	15	<b>Unsign I&gt;=V</b> Check to see if the unsigned value of <i>Function In3</i> is greater than or equal to the value of <i>Func3 Mask/Val</i> .
4	<b>Any Bit On</b> Check to make sure that at least one of the bits that are set in <i>Func3 Mask/Val</i> is set in <i>Function In3</i> .	10	<b>Signed I&gt;V</b> Check to see if the signed value of <i>Function In3</i> is greater than the value of <i>Func3 Mask/Val</i> .	16	<b>Invert</b> Pass the opposite value on to the function block
5	<b>Any Bit Off</b> Check to make sure that at least one of the bits that are set in <i>Func3 Mask/Val</i> is clear in <i>Function In3</i> .	11	<b>Signed I&gt;=V</b> Check to see if the signed value of <i>Function In3</i> is greater than or equal to the value of <i>Func3 Mask/Val</i> .	17	<b>Absolute</b> Pass a positive value on to the function block.

<b>207</b>	<b>Function In4<sup>1</sup></b>	<p>Use <i>Function In4</i> to provide input to the function block that is provided with the 1336 IMPACT drive.</p> <p>For the timer delay and state machine function blocks, <i>Function In4</i> is used to specify how long after the timer off input is received before turning off the timer output. When used for these modes, the timer off signal must be present for as long as you specify in <i>Function In4</i>.</p> <p>For the up/down counter function block, <i>Function In4</i> specifies how much to add to the value when <i>Function In1</i> (parameter 198) indicates that a rising edge has occurred.</p> <p>For the multiply/divide function block, <i>Function In4</i> specifies whether the function should be performed as a per unit function or as a math function.</p> <p>For the scale function block, <i>Function In4</i> is the upper word of the value that you want to use as either the minimum or maximum value for the output. The lower word of this value is specified in <i>Function In5</i> (parameter 208).</p> <p>1 <i>Function In4</i> was added in Version 2.xx.</p>	<b>Parameter number</b>	207
			<b>File:group</b>	Application:Prog Function linkable destination
			<b>Parameter type</b>	
			<b>Conversion</b>	1 = 1
			<b>Display</b>	xxx.xx minutes
			<b>Factory default</b>	0.00 minutes
			<b>Minimum value</b>	0.00 minutes
			<b>Maximum value</b>	655.35 minutes
			<b>Display</b>	x
			<b>Factory default</b>	0
			<b>Minimum value</b>	0
			<b>Maximum value</b>	65535
			<b>Display</b>	±x
			<b>Factory default</b>	0
			<b>Minimum value</b>	-32767
			<b>Maximum value</b>	+32767
			Refer to Chapter 10, <i>Using the Function Block</i> , for more information.	

<b>208</b>	<b>Function In5<sup>1</sup></b>	<p>Use <i>Function In5</i> to provide input to the function block that is provided with the 1336 IMPACT drive.</p> <p>For the timer delay and state machine function blocks, <i>Function In5</i> is used to specify how long after the timer on input is received before turning on the timer output. When used for these modes, the timer on signal must be present for as long as you specify in <i>Function In5</i>.</p> <p>For the up/down counter function block, <i>Function In5</i> specifies how much to subtract from the value when <i>Function In2</i> (parameter 201) indicates that a rising edge has occurred.</p> <p>For the scale function block, <i>Function In5</i> is the lower word of the value that you want to use as either the minimum or maximum value for the output. The upper word of this value is specified in <i>Function In4</i> (parameter 207).</p>	<b>Parameter number</b>	208
			<b>File:group</b>	Application:Prog Function
			<b>Parameter type</b>	linkable destination
			<b>Conversion</b>	1 = 1
			If <i>Function Sel</i> (parameter 212) is 0 – 8, then:	
			<b>Display</b>	xxx.xx minutes
			<b>Factory default</b>	0.00 minutes
			<b>Minimum value</b>	0.00 minutes
			<b>Maximum value</b>	655.35 minutes
			If <i>Function Sel</i> (parameter 212) is 9 – 13, then:	
			<b>Display</b>	x
			<b>Factory default</b>	0
			<b>Minimum value</b>	0
			<b>Maximum value</b>	65535
			Refer to Chapter 10, <i>Using the Function Block</i> , for more information.	
		<sup>1</sup>	<i>Function In5</i> was added in Version 2.xx.	

<b>209</b>	<b>Function In6<sup>1</sup></b>	<p>Use <i>Function In6</i> to provide input to the function block that is provided with the the 1336 IMPACT drive.</p> <p>For the timer delay function block, <i>Function In6</i> specifies the value to pass to <i>Function Output 1</i> (parameter 213) when the timer delay output is true.</p> <p>For the state machine function block, <i>Function In6</i> is used for the output if the evaluation of <i>Function In2</i> (parameter 201) is false and the evaluation of <i>Function In1</i> (parameter 198) and the timer on function are true.</p> <p>For the up/down counter function block, <i>Function In6</i> specifies whether the output is a double word (if <i>Function In6</i> is true) or a word (if <i>Function In6</i> is false).</p> <p>For the scale function block, <i>Function In6</i> is the upper word of the value that you want to use as either the minimum or maximum value for the output. The lower word of this value is specified in <i>Function In7</i> (parameter 210).</p>	<b>Parameter number</b>	209
			<b>File:group</b>	Application:Prog Function
			<b>Parameter type</b>	linkable destination
			<b>Conversion</b>	1 = 1
			If <i>Function Sel</i> (parameter 212) is 0 – 10 or 12, then:	
			<b>Display</b>	bits
			<b>Factory default</b>	00000000.00000000
			<b>Minimum value</b>	00000000.00000000
			<b>Maximum value</b>	11111111.11111111
			If <i>Function Sel</i> (parameter 212) is 11, then:	
			<b>Display</b>	x
			<b>Factory default</b>	0
			<b>Minimum value</b>	0
			<b>Maximum value</b>	65535
			If <i>Function Sel</i> (parameter 212) is 13, then:	
			<b>Display</b>	±x
			<b>Factory default</b>	0
			<b>Minimum value</b>	-32767
			<b>Maximum value</b>	+32767
			Refer to Chapter 10, <i>Using the Function Block</i> , for more information.	
		<sup>1</sup>	<i>Function In6</i> was added in Version 2.xx.	



<b>210</b>	<b>Function In7<sup>1</sup></b>	<p>Use <i>Function In7</i> to provide input to the function block that is provided with the 1336 IMPACT drive.</p> <p>For the timer delay function block, <i>Function In7</i> specifies the value to pass to <i>Function Output 1</i> (parameter 213) when the timer delay evaluation is false.</p> <p>For the state machine function block <i>Function In7</i> is used for the output if the evaluation of <i>Function In2</i> (parameter 201) is true and the evaluation of <i>Function In1</i> (parameter 198) and the timer function are false.</p> <p>For the scale function, <i>Function In7</i> is the lower word of the value that you want to use as either the minimum or maximum value for the output. The upper word of this value is specified in <i>Function In6</i> (parameter 209).</p> <p>For the counter function, <i>Function In7</i> is used for the Cnt Clr value. By default, the value is 0. This value can be changed by the user.</p> <p><sup>1</sup> <i>Function In7</i> was added in Version 2.xx.</p>	<p><b>Parameter number</b> 210</p> <p><b>File:group</b> Application:Prog Function</p> <p><b>Parameter type</b> linkable destination</p> <p><b>Conversion</b> 1 = 1</p> <p>If <i>Function Sel</i> (parameter 212) is 0 – 10, 12, then:</p> <p><b>Display</b> bits</p> <p><b>Factory default</b> 00000000.00000000</p> <p><b>Minimum value</b> 00000000.00000000</p> <p><b>Maximum value</b> 11111111.11111111</p> <p>If <i>Function Sel</i> (parameter 212) is 11</p> <p><b>Display</b> ±x</p> <p><b>Factory default</b> 0</p> <p><b>Minimum value</b> -32767</p> <p><b>Maximum value</b> +32767</p> <p>If <i>Function Sel</i> (parameter 212) is 13, then:</p> <p><b>Display</b> ±x</p> <p><b>Factory default</b> 0</p> <p><b>Minimum value</b> 0</p> <p><b>Maximum value</b> 65535</p> <p>Refer to Chapter 10, <i>Using the Function Block</i>, for more information.</p>
<b>211</b>	<b>Function In8<sup>1</sup></b>	<p>Use <i>Function In8</i> to provide input to the function block that is provided with the 1336 IMPACT drive.</p> <p>For the state machine function block, <i>Function In8</i> is used for the output if the evaluation of <i>Function In2</i> (parameter 201) is true and the evaluation of <i>Function In1</i> (parameter 198) and the timer on function are true.</p> <p><sup>1</sup> <i>Function In8</i> was added in Version 2.xx.</p>	<p><b>Parameter number</b> 211</p> <p><b>File:group</b> Application:Prog Function</p> <p><b>Parameter type</b> linkable destination</p> <p><b>Display</b> bits</p> <p><b>Factory default</b> 00000000.00000000</p> <p><b>Minimum value</b> 00000000.00000000</p> <p><b>Maximum value</b> 11111111.11111111</p> <p><b>Conversion</b> 1 = 1</p> <p>Refer to Chapter 10, <i>Using the Function Block</i>, for more information.</p>

**212 Function Sel<sup>1</sup>**

Use *Function Sel* to select which function you would like the function block to perform.

1 *Function Sel* was added in Version 2.xx.

<b>Parameter number</b>	212
<b>File:group</b>	Application:Prog Function destination
<b>Parameter type</b>	
<b>Display</b>	x
<b>Factory default</b>	0
<b>Minimum value</b>	0
<b>Maximum value</b>	27
<b>Conversion</b>	1 = 1

Refer to Chapter 10, *Using the Function Block*, for more information.

Value	Description	Value	Description	Value	Description
0	<b>Or Tmr</b> Take the OR of input 1 and input 2 and use the result for the timer input.	10	<b>Max/Min</b> Compare input 1 with input 2 and based on input 3, output whichever value is larger or smaller.	20	<b>Or And Add</b> Take the result of input 1 OR'ed with input 2 and AND with input 3. Then, use the result for the add/sub input.
1	<b>Nor Tmr</b> Take the NOR of input 1 and input 2 and use the result for the timer input.	11	<b>Counter</b> Count up (input 1) or down (input 2).	21	<b>And Or Add</b> Take the result of input 1 AND input 2 and OR with input 3. Then, use the result for the add/sub input.
2	<b>And Tmr</b> Take the AND of input 1 and input 2 and use the result for the timer input.	12	<b>Mult/Div</b> Multiply input 1 and input 2 and then divide by input 3.	22	<b>Or Mult</b> Take the OR of input 1 and input 2 and use the result for the mult/div input.
3	<b>Nand Tmr</b> Take the NAND of input 1 and input 2 and use the result for the timer input.	13	<b>Scale</b> Scale the value of input 1 from one range to another.	23	<b>Nor Mult</b> Take the NOR of input 1 and input 2 and use the result for the mult/div input.
4	<b>Or And Tmr</b> Take the result of input 1 OR'ed with input 2 and AND with input 3. Then, use the result for the timer input.	14	<b>Hysteresis</b> Create Hysteresis band (In4-Hi, In5-Lo) for Input 1.	24	<b>And Mult</b> Take the AND of input 1 and input 2 and use the result for the mult/div input.
5	<b>And Or Tmr</b> Take the result of input 1 AND input 2 and OR with input 3. Then, use the result for the timer input.	15	<b>Band</b> Create Band (In4-Hi, In5-Lo) for Input 1.	25	<b>Nand Mult</b> Take the NAND of input 1 and input 2 and use the result for the mult/div input.
6	<b>Tmr Or And</b> Use input 1 for the timer input and OR with input 2. Then, AND with input 3.	16	<b>Or Add</b> Take the OR of input 1 and input 2 and use the result for the add/sub input.	26	<b>Or And Mult</b> Take the result of input 1 OR'ed with input 2 and AND with input 3. Then, use the result for the mult/div input.
7	<b>Tmr And Or</b> Use input 1 for the timer input and AND with input 2. Then, OR with input 3.	17	<b>Nor Add</b> Take the NOR of input 1 and input 2 and use the result for the add/sub input.	27	<b>And Or Mult</b> Take the result of input 1 AND input 2 and OR with input 3. Then, use the result for the mult/div input.
8	<b>StateMachine</b> Change the output value based on the value of input 1/timer and input 2.	18	<b>And Add</b> Take the AND of input 1 and input 2 and use the result for the add/sub input.		
9	<b>Add/Sub</b> Add input 1 and input 2.	19	<b>Nand Add</b> Take the NAND of input 1 and input 2 and use the result for the add/sub input.		

213	<b>Function Output 1<sup>1</sup></b>	Use <i>Function Output 1</i> to view the results of the function block. <i>Function Output 1</i> is either a word value or the upper byte of a double word, depending on the value of <i>Function Sel</i> (parameter 212).	<p><b>Parameter number</b> 213</p> <p><b>File:group</b> Application:Prog Function</p> <p><b>Parameter type</b> source</p> <p><b>Factory default</b> not applicable</p> <p><b>Conversion</b> 1 = 1</p> <p>If <i>Function Sel</i> (parameter 212) is 0 – 8, then:</p> <p><b>Display</b> bits</p> <p><b>Minimum value</b> 00000000.00000000</p> <p><b>Maximum value</b> 11111111.11111111</p> <p>If <i>Function Sel</i> (parameter 212) is 9, 10, 12 or 13, then:</p> <p><b>Display</b> ±x</p> <p><b>Minimum value</b> -32767</p> <p><b>Maximum value</b> +32767</p> <p>If <i>Function Sel</i> (parameter 212) is 11, then:</p> <p><b>Display</b> x</p> <p><b>Minimum value</b> 0</p> <p><b>Maximum value</b> 65535</p> <p>Refer to Chapter 10, <i>Using the Function Block</i>, for more information.</p>	1 <i>Function Output 1</i> was added in Version 2.xx.											
214	<b>Function Output2<sup>1</sup></b>	Use <i>Function Output 2</i> to view the results of the function block. <i>Function Output 2</i> is the lower byte of a double word <i>Function Sel</i> (parameter 212) is 11, 12, or 13.	<p><b>Parameter number</b> 214</p> <p><b>File:group</b> Application:Prog Function</p> <p><b>Parameter type</b> source</p> <p><b>Display</b> x</p> <p><b>Factory default</b> not applicable</p> <p><b>Minimum value</b> 0</p> <p><b>Maximum value</b> 65535</p> <p><b>Conversion</b> 1 = 1</p> <p>Refer to Chapter 10, <i>Using the Function Block</i>, for more information.</p>	1 <i>Function Output 2</i> was added in Version 2.xx.											
215	<b>Min Speed Limit<sup>1</sup></b>	Use <i>Min Speed Limit</i> to specify the minimum speed that you want the motor to run at. <i>Min Speed Limit</i> overrides any speed references to lower speeds.	<p><b>Parameter number</b> 215</p> <p><b>File:group</b> Control:Control Limits</p> <p><b>Parameter type</b> linkable destination</p> <p><b>Display</b> x.x rpm</p> <p><b>Factory default</b> 0.0 rpm</p> <p><b>Minimum value</b> 0.0 rpm</p> <p><b>Maximum value</b> base motor speed</p> <p><b>Conversion</b> 4096 = base motor speed</p>	1 <i>Min Speed Limit</i> was added in Version 2.xx.											
216	<b>Fstart Select<sup>1</sup></b>	Use <i>Fstart Select</i> to activate the flying start feature when operating in <i>Encoderless</i> mode. This allows encoderless mode the ability to reconnect into a rotating motor and resume operation.	<p><b>Parameter number</b> 216</p> <p><b>File:group</b> Application: Flying Start</p> <p><b>Parameter type</b> linkable destination</p> <p><b>Display</b> x</p> <p><b>Factory default</b> 0</p> <p><b>Minimum value</b> 0</p> <p><b>Maximum value</b> 2</p> <p><b>Conversion</b> 1 = 1</p> <p>Refer to Chapter 9, <i>Applications</i>, for more information.</p>	<b>Note:</b> <i>Encoder</i> mode will automatically reconnect and does not use the <i>Fstart Select</i> parameter.											
	1 <i>Fstart Select</i> was added in Version 3.xx.	<table border="1"> <thead> <tr> <th>Display#</th> <th>Display Text</th> <th>Description</th> </tr> </thead> <tbody> <tr> <td>0</td> <td>Disabled</td> <td>Flying start disabled</td> </tr> <tr> <td>1</td> <td>Last Speed</td> <td>Flying start enabled — Beginning search from last known speed</td> </tr> <tr> <td>2</td> <td>Speed Param</td> <td>Flying start enabled — Beginning search from <i>Fstart Speed</i> (parameter 217)</td> </tr> </tbody> </table>	Display#	Display Text	Description	0	Disabled	Flying start disabled	1	Last Speed	Flying start enabled — Beginning search from last known speed	2	Speed Param	Flying start enabled — Beginning search from <i>Fstart Speed</i> (parameter 217)	
Display#	Display Text	Description													
0	Disabled	Flying start disabled													
1	Last Speed	Flying start enabled — Beginning search from last known speed													
2	Speed Param	Flying start enabled — Beginning search from <i>Fstart Speed</i> (parameter 217)													

<b>217</b>	<b>Fstart Speed<sup>1</sup></b>	<b>Parameter number</b> 217
	Use <i>Fstart Speed</i> to set the start point at which the speed search begins. This parameter is only active when operating in <i>Fstart Select</i> mode 2 ( <i>Speed Param</i> ).	<b>File:group</b> Application: Flying Start
	To maximize reconnect performance, always set the <i>Fstart Speed</i> slightly greater than the expected reconnect motor speed.	<b>Parameter type</b> linkable destination
	1 <i>Fstart Speed</i> was added in Version 3.xx.	<b>Display</b> x.x RPM
		<b>Factory default</b> + base motor speed rpm
		<b>Minimum value</b> Rev Speed Limit (Param 40)
		<b>Maximum value</b> Forward Speed Limit (Param 41)
		<b>Conversion</b> +4096 = base motor speed
		Refer to Chapter 9, <i>Applications</i> , for more information.

<b>218</b>	<b>Reserved</b>	<b>Parameter number</b> 218
	Leave this parameter set to 0.	<b>File:group</b>
		<b>Parameter type</b>
		<b>Display</b>
		<b>Factory default</b>
		<b>Minimum value</b>
		<b>Maximum value</b>
		<b>Conversion</b>

<b>219</b>	<b>PwrUp Flt Status<sup>1</sup></b>	<b>Parameter number</b> 219
	<i>PwrUp Flt Status</i> indicates that a fault condition has been detected during power up or reset of the drive. When a bit is “1”, the condition is true; otherwise, the condition is false.	<b>File:group</b> Monitor: Fault Status
	1 <i>PwrUp Flt Status</i> was added in Version 3.xx.	<b>Parameter type</b> source
		<b>Display</b> Bits
		<b>Factory default</b> 0000 0000 0000 0000
		<b>Minimum value</b> 0000 0000 0000 0000
		<b>Maximum value</b> 1111 1111 1111 1111
		<b>Conversion</b> 1 = 1

Bit	Condition	Bit	Condition	Bit	Condition
0	CP EPROM	6	Reserved	12	VP MBI
1	CP Int RAM	7	Reserved	13	Reserved
2	CP Ext RAM	8	VP EPROM	14	EE Checksum
3	CP Stack Ram	9	VP Int Ram	15	EE R/W
4	CP MBI	10	VP Ext Ram		
5	Reserved	11	VP Stack RAM		

<b>220</b>	<b>Ncfg Flt Status<sup>1</sup></b>	<b>Parameter number</b> 220
	<i>Ncfg Flt Status</i> indicates that a fault condition in the drive CANNOT be configured as a warning. When a bit is “1”, the condition is true; otherwise, the condition is false. Bits 0 – 3 are detected by hardware. Bits 4 – 15 are detected are detected by software.	<b>File:group</b> Monitor: Fault Status
	1 <i>Ncfg Flt Status</i> was added in Version 3.xx.	<b>Parameter type</b> source
		<b>Display</b> Bits
		<b>Factory default</b> 0000 0000 0000 0000
		<b>Minimum value</b> 0000 0000 0000 0000
		<b>Maximum value</b> 1111 1111 1111 1111
		<b>Conversion</b> 1 = 1

Bit	Condition	Bit	Condition	Bit	Condition
0	Bus Overvolt	6	Dr Type Dif	12	Inv Temp Trp
1	Trans Desat	7	Ill Drv Type	13	Task Overrun
2	Ground Flt	8	CP Handshake	14	Ill Interrupt
3	IOC	9	Abs overspd	15	Mode Timeout
4	VP Handshake	10	+/- 15v Tol		
5	Diff SW Ver	11	Auto/Diag		

<b>221</b>	<b>Fault Status 1<sup>1</sup></b>	<p><i>Fault Status 1</i> shows fault conditions that have been configured to report as drive fault conditions. Each configuration bit matches the bit definitions of <i>Fault Select 1</i> (parameter 20) and <i>Fault Select 2</i> (parameter 22). When a bit is “1” the condition is true; otherwise, the condition is false.</p> <p>1 <i>Fault Status 1</i> was added in Version 3.xx.</p>	<p><b>Parameter number</b> 221  <b>File:group</b> Monitor: Fault Status  <b>Parameter type</b> source  <b>Display</b> Bits  <b>Factory default</b> 0000 0000 0000 0000  <b>Minimum value</b> 0000 0000 0000 0000  <b>Maximum value</b> 1111 1111 1111 1111  <b>Conversion</b> 1 = 1</p> <p>Refer to Chapter 12, <i>Troubleshooting</i>, for more information.</p>																																							
				<table border="1"> <thead> <tr> <th>Bit</th> <th>Condition</th> <th>Bit</th> <th>Condition</th> <th>Bit</th> <th>Condition</th> </tr> </thead> <tbody> <tr> <td>0</td> <td>Ridethru Time</td> <td>6</td> <td>Reserved</td> <td>12</td> <td>SP 4 Timeout</td> </tr> <tr> <td>1</td> <td>Prechrg Time</td> <td>7</td> <td>Reserved</td> <td>13</td> <td>SP 5 Timeout</td> </tr> <tr> <td>2</td> <td>Bus Drop</td> <td>8</td> <td>mA Input</td> <td>14</td> <td>SP 6 Timeout</td> </tr> <tr> <td>3</td> <td>Bus Undervlt</td> <td>9</td> <td>SP 1 Timeout</td> <td>15</td> <td>SP Error</td> </tr> <tr> <td>4</td> <td>Bus Cycles&gt;5</td> <td>10</td> <td>SP 2 Timeout</td> <td></td> <td></td> </tr> <tr> <td>5</td> <td>Open Circuit</td> <td>11</td> <td>SP 3 Timeout</td> <td></td> <td></td> </tr> </tbody> </table>	Bit	Condition	Bit	Condition	Bit	Condition	0	Ridethru Time	6	Reserved	12	SP 4 Timeout	1	Prechrg Time	7	Reserved	13	SP 5 Timeout	2	Bus Drop	8	mA Input	14	SP 6 Timeout	3	Bus Undervlt	9	SP 1 Timeout	15	SP Error	4	Bus Cycles>5	10	SP 2 Timeout			5	Open Circuit
Bit	Condition	Bit	Condition	Bit	Condition																																					
0	Ridethru Time	6	Reserved	12	SP 4 Timeout																																					
1	Prechrg Time	7	Reserved	13	SP 5 Timeout																																					
2	Bus Drop	8	mA Input	14	SP 6 Timeout																																					
3	Bus Undervlt	9	SP 1 Timeout	15	SP Error																																					
4	Bus Cycles>5	10	SP 2 Timeout																																							
5	Open Circuit	11	SP 3 Timeout																																							

<b>222</b>	<b>Fault Status 2<sup>1</sup></b>	<p><i>Fault Status 2</i> shows fault conditions that have been configured to report as drive fault conditions. Each configuration bit matches the bit definitions of <i>Fault Select 1</i> (parameter 20) and <i>Fault Select 2</i> (parameter 22). When a bit is “1” the condition is true; otherwise, the condition is false.</p> <p>1 <i>Fault Status 2</i> was added in Version 3.xx.</p>	<p><b>Parameter number</b> 222  <b>File:group</b> Monitor: Fault Status  <b>Parameter type</b> source  <b>Display</b> Bits  <b>Factory default</b> 0000 0000 0000 0000  <b>Minimum value</b> 0000 0000 0000 0000  <b>Maximum value</b> 1111 1111 1111 1111  <b>Conversion</b> 1 = 1</p> <p>Refer to Chapter 12, <i>Troubleshooting</i>, for more information.</p>																																							
				<table border="1"> <thead> <tr> <th>Bit</th> <th>Condition</th> <th>Bit</th> <th>Condition</th> <th>Bit</th> <th>Condition</th> </tr> </thead> <tbody> <tr> <td>0</td> <td>SpdFdbk Loss</td> <td>6</td> <td>Ext Fault In</td> <td>12</td> <td>Reserved</td> </tr> <tr> <td>1</td> <td>InvOvtmp Pnd</td> <td>7</td> <td>Reserved</td> <td>13</td> <td>InOvld Pend</td> </tr> <tr> <td>2</td> <td>Reserved</td> <td>8</td> <td>Reserved</td> <td>14</td> <td>Reserved</td> </tr> <tr> <td>3</td> <td>MtrOvld Pend</td> <td>9</td> <td>Param Limit</td> <td>15</td> <td>InvOvld Trip</td> </tr> <tr> <td>4</td> <td>MtrOvld Trip</td> <td>10</td> <td>Math Limit</td> <td></td> <td></td> </tr> <tr> <td>5</td> <td>Mtr Stall</td> <td>11</td> <td>Reserved</td> <td></td> <td></td> </tr> </tbody> </table>	Bit	Condition	Bit	Condition	Bit	Condition	0	SpdFdbk Loss	6	Ext Fault In	12	Reserved	1	InvOvtmp Pnd	7	Reserved	13	InOvld Pend	2	Reserved	8	Reserved	14	Reserved	3	MtrOvld Pend	9	Param Limit	15	InvOvld Trip	4	MtrOvld Trip	10	Math Limit			5	Mtr Stall
Bit	Condition	Bit	Condition	Bit	Condition																																					
0	SpdFdbk Loss	6	Ext Fault In	12	Reserved																																					
1	InvOvtmp Pnd	7	Reserved	13	InOvld Pend																																					
2	Reserved	8	Reserved	14	Reserved																																					
3	MtrOvld Pend	9	Param Limit	15	InvOvld Trip																																					
4	MtrOvld Trip	10	Math Limit																																							
5	Mtr Stall	11	Reserved																																							

<b>223</b>	<b>Warning Status 1<sup>1</sup></b>	<p><i>Warning Status 1</i> shows warning conditions that have been configured to report as drive warning conditions. Each configuration bit matches the bit definitions of <i>Warning Select 1</i> (parameter 21) and <i>Warning Select 2</i> (parameter 23). When a bit is “1” the condition is true; otherwise, the condition is false.</p> <p>1 <i>Warning Status 1</i> was added in Version 3.xx.</p>	<p><b>Parameter number</b> 223  <b>File:group</b> Monitor: Fault Status  <b>Parameter type</b> source  <b>Display</b> Bits  <b>Factory default</b> 0000 0000 0000 0000  <b>Minimum value</b> 0000 0000 0000 0000  <b>Maximum value</b> 1111 1111 1111 1111  <b>Conversion</b> 1 = 1</p> <p>Refer to Chapter 12, <i>Troubleshooting</i>, for more information.</p>																																							
				<table border="1"> <thead> <tr> <th>Bit</th> <th>Condition</th> <th>Bit</th> <th>Condition</th> <th>Bit</th> <th>Condition</th> </tr> </thead> <tbody> <tr> <td>0</td> <td>Ridethru Time</td> <td>6</td> <td>Reserved</td> <td>12</td> <td>SP 4 Timeout</td> </tr> <tr> <td>1</td> <td>Prechrg Time</td> <td>7</td> <td>Reserved</td> <td>13</td> <td>SP 5 Timeout</td> </tr> <tr> <td>2</td> <td>Bus Drop</td> <td>8</td> <td>mA Input</td> <td>14</td> <td>SP 6 Timeout</td> </tr> <tr> <td>3</td> <td>Bus Undervlt</td> <td>9</td> <td>SP 1 Timeout</td> <td>15</td> <td>SP Error</td> </tr> <tr> <td>4</td> <td>Bus Cycles&gt;5</td> <td>10</td> <td>SP 2 Timeout</td> <td></td> <td></td> </tr> <tr> <td>5</td> <td>Open Circuit</td> <td>11</td> <td>SP 3 Timeout</td> <td></td> <td></td> </tr> </tbody> </table>	Bit	Condition	Bit	Condition	Bit	Condition	0	Ridethru Time	6	Reserved	12	SP 4 Timeout	1	Prechrg Time	7	Reserved	13	SP 5 Timeout	2	Bus Drop	8	mA Input	14	SP 6 Timeout	3	Bus Undervlt	9	SP 1 Timeout	15	SP Error	4	Bus Cycles>5	10	SP 2 Timeout			5	Open Circuit
Bit	Condition	Bit	Condition	Bit	Condition																																					
0	Ridethru Time	6	Reserved	12	SP 4 Timeout																																					
1	Prechrg Time	7	Reserved	13	SP 5 Timeout																																					
2	Bus Drop	8	mA Input	14	SP 6 Timeout																																					
3	Bus Undervlt	9	SP 1 Timeout	15	SP Error																																					
4	Bus Cycles>5	10	SP 2 Timeout																																							
5	Open Circuit	11	SP 3 Timeout																																							

<b>224</b>	<b>Warning Status 2<sup>1</sup></b>	<b>Parameter number</b>	224
	<i>Warning Status 2</i> shows warning conditions that have been configured to report as drive warning conditions. Each configuration bit matches the bit definitions of <i>Warning Select 1</i> (parameter 21) and <i>Warning Select 2</i> (parameter 23). When a bit is "1" the condition is true; otherwise, the condition is false.	<b>File:group</b>	Monitor: Fault Status
		<b>Parameter type</b>	source
		<b>Display</b>	Bits
		<b>Factory default</b>	0000 0000 0000 0000
		<b>Minimum value</b>	0000 0000 0000 0000
		<b>Maximum value</b>	1111 1111 1111 1111
		<b>Conversion</b>	1 = 1
	1 <i>Warning Status 2</i> was added in Version 3.xx.	Refer to Chapter 12, <i>Troubleshooting</i> , for more information.	
	<b>Bit</b>	<b>Condition</b>	<b>Bit</b>
	0	SpdFdbk Loss	6
	1	Inv Overtemp	7
	2	Reserved	8
	3	MtrOvld Pend	9
	4	MtrOvld Trip	10
	5	Mtr Stall2	11
			12
			13
			14
			15
			Reserved
			InvOvld Pend
			Reserved
			Inv Overload
<b>225</b>	<b>Spd Reg Output<sup>1</sup></b>	<b>Parameter number</b>	225
	<i>Spd Reg Output</i> shows the torque reference value that appears at the output of the Speed PI Regulator. It is the input to the torque selection and is used as the drive's torque reference value when <i>Spd/Trq Mode Sel</i> (parameter 68) is set to 2.	<b>File:group</b>	Monitor: Drive/Inv Status
		<b>Parameter type</b>	source
		<b>Display</b>	±x.xx %
		<b>Factory default</b>	+ 0.0%
		<b>Minimum value</b>	- 300.0%
		<b>Maximum value</b>	+ 300.0%
		<b>Conversion</b>	4096 = 100 Iq motor%
	1 <i>Spd Reg Output</i> was added in Version 3.xx.		
<b>226</b>	<b>Spd Error<sup>1</sup></b>	<b>Parameter number</b>	226
	<i>Spd Error</i> contains a value that is the difference between the whole number portion of the speed regulator's reference input and the speed feedback.	<b>File:group</b>	Monitor: Drive/Inv Status
		<b>Parameter type</b>	source
		<b>Display</b>	±x.xx rpm
		<b>Factory default</b>	+ 0.0 rpm
		<b>Minimum value</b>	- 8 x base speed
		<b>Maximum value</b>	+ 8 x base speed
		<b>Conversion</b>	4096 = base motor speed
	1 <i>Speed Error</i> was added in Version 3.xx.		
<b>227</b>	<b>Enc Pos Fdbk Low<sup>1</sup></b>	<b>Parameter number</b>	227
	<i>Enc Pos Fdbk Low</i> shows the LOW word portion of a 32 bit encoder pulse accumulator. Each encoder quadrature edge will be counted, resulting in a 4X multiplication. As a result, this parameter will be scaled such that the position change per motor revolution is equal to 4 times the encoder PPR.	<b>File:group</b>	Monitor: Motor Status
		<b>Parameter type</b>	source
		<b>Display</b>	x
		<b>Factory default</b>	0
		<b>Minimum value</b>	0
		<b>Maximum value</b>	65535
		<b>Conversion</b>	1 = 1
	1 <i>Enc Pos Fdbk Low</i> was added in Version 3.xx.		
<b>228</b>	<b>Enc Pos Fdbk Hi<sup>1</sup></b>	<b>Parameter number</b>	228
	<i>Enc Pos Fdbk Hi</i> shows the HI word portion of a 32 bit encoder pulse accumulator that was described in the previous parameter. This word will change by 1 count for every change in low count of 65,536 4x encoder pulses.	<b>File:group</b>	Monitor: Motor Status
		<b>Parameter type</b>	source
		<b>Display</b>	x
		<b>Factory default</b>	0
		<b>Minimum value</b>	0
		<b>Maximum value</b>	65535
		<b>Conversion</b>	1 = 1
	1 <i>Enc Pos Fdbk Hi</i> was added in Version 3.xx.		

229	<p><b>Int Torque Ref<sup>1</sup></b></p> <p><i>Int Torque Ref</i> shows the value of torque reference that is present at the output of the torque limiter.</p> <p>1 <i>Int Torque Ref</i> was added in Version 3.xx.</p>	<p><b>Parameter number</b> 229</p> <p><b>File:group</b> Monitor: Motor Status</p> <p><b>Parameter type</b> source</p> <p><b>Display</b> ±x.x%</p> <p><b>Factory default</b> 0.0%</p> <p><b>Minimum value</b> -800%</p> <p><b>Maximum value</b> +800%</p> <p><b>Conversion</b> 4096 = Rated Torque</p>
230	<p><b>Iq Offset<sup>1</sup></b></p> <p><i>Iq Offset</i> contains the LEM U offset required to null the current error (no motor current flowing). This offset is set automatically by running the transistor diagnostics.</p> <p>1 <i>Iq Offset</i> was added in Version 3.xx.</p>	<p><b>Parameter number</b> 230</p> <p><b>File:group</b> None</p> <p><b>Parameter type</b> linkable destination</p> <p><b>Display</b> ±x</p> <p><b>Factory default</b> 0</p> <p><b>Minimum value</b> -100</p> <p><b>Maximum value</b> +100</p> <p><b>Conversion</b> 1 = 1</p>
231	<p><b>Id Offset<sup>1</sup></b></p> <p><i>Id Offset</i> contains the LEM W offset required to null the current error (no motor current flowing). This offset is set automatically by running the transistor diagnostics.</p> <p>1 <i>Id Offset</i> was added in Version 3.xx.</p>	<p><b>Parameter number</b> 231</p> <p><b>File:group</b> None</p> <p><b>Parameter type</b> linkable destination</p> <p><b>Display</b> ±x</p> <p><b>Factory default</b> 0</p> <p><b>Minimum value</b> -100</p> <p><b>Maximum value</b> +100</p> <p><b>Conversion</b> 1 = 1</p>
232	<p><b>Function In9<sup>1</sup></b></p> <p>Use <i>Function In9</i> to provide input to the function block that is provided with the 1336 IMPACT drive.</p> <p>1 <i>Function In9</i> was added in Version 3.xx.</p>	<p><b>Parameter number</b> 232</p> <p><b>File:group</b> Application: Prog Function</p> <p><b>Parameter type</b> sink</p> <p><b>Display</b> ±x</p> <p><b>Factory default</b> 0</p> <p><b>Minimum value</b> -32767</p> <p><b>Maximum value</b> +32767</p> <p><b>Conversion</b> 1 = 1</p> <p>Refer to Chapter 10, <i>Using the Function Block</i>, for more information.</p>
233	<p><b>Function In10<sup>1</sup></b></p> <p>Use <i>Function In10</i> to provide input to the function block that is provided with the 1336 IMPACT drive.</p> <p>1 <i>Function In10</i> was added in Version 3.xx.</p>	<p><b>Parameter number</b> 233</p> <p><b>File:group</b> Application: Prog Function</p> <p><b>Parameter type</b> sink</p> <p><b>Display</b> ±x</p> <p><b>Factory default</b> 0</p> <p><b>Minimum value</b> -32767</p> <p><b>Maximum value</b> +32767</p> <p><b>Conversion</b> 1 = 1</p> <p>Refer to Chapter 10, <i>Using the Function Block</i>, for more information.</p>
234	<p><b>Motor Voltage %<sup>1</sup></b></p> <p>Use <i>Motor Voltage %</i> to view the actual line-to-line fundamental RMS value of motor voltage as a percentage. This data is averaged and updated every 50 milliseconds.</p> <p>1 <i>Motor Voltage</i> was added in Version 3.xx.</p>	<p><b>Parameter number</b> 234</p> <p><b>File:group</b> Monitor:Motor Status</p> <p><b>Parameter type</b> source</p> <p><b>Display</b> x.x%</p> <p><b>Factory default</b> NA</p> <p><b>Minimum value</b> 0%</p> <p><b>Maximum value</b> 800%</p> <p><b>Conversion</b> 4096 = motor volts</p>

<b>235</b>	<b>Profile Enable</b>	<b>Parameter number</b> <b>File:group</b> <b>Parameter type</b> <b>Display</b> <b>Factory default</b> <b>Minimum value</b> <b>Maximum value</b> )Fhex <b>Conversion</b>	235 Profile Command Setup Bits 0 000Fhex
Profile Enable is the command word for speed profiling. Bit 0 - Sets the home position and must be set to 1 for profiling to operate. Bit 1 - Must be set to run the sequence of the speed profile that is programmed. Bit 2 - When set to 1, causes the transition from one step to the next to be held until the bit is set to 0. Bit 3 - Is used with the sequential encoder steps and prevents the speed from dropping to zero at the end of each step. Bits 4-7 - Reserved			
<b>236</b>	<b>Profile Status</b>	<b>Parameter number</b> <b>File:group</b> <b>Parameter type</b> <b>Display</b> <b>Factory default</b> <b>Minimum value</b> <b>Maximum value</b> <b>Conversion</b>	236 Profile Command Setup Bits 0 0000hex 001Fhex
Profile Status indicates the state of the profiling routine. Bits 0-4 - Indicate the binary value of active step, 1-16. Bit 5 - Enabled when set to 1. Bit 6 - Run Sequence on when set to 1. This bit clears when sequence is complete. Bit 7 - Hold is active when set to 1. Bit 8 - Encoder Velocity Blend mode selected when set to 1.			
<b>237</b>	<b>Error Trim Gain</b>	<b>Parameter number</b> <b>File:group</b> <b>Parameter type</b> <b>Display</b> <b>Factory default</b> <b>Minimum value</b> <b>Maximum value</b> <b>Conversion</b>	237 Profile Command Setup x.x units 2 0.5 16.0 128 = 1.0
Sets the gain for the speed profiling control in a range from 0.5 - 16.0. When sending values over a network connection, the scaling is 128 = 1.0			
<b>238</b>	<b>End Action Sel</b>	<b>Parameter number</b> <b>File:group</b> <b>Parameter type</b> <b>Display</b> <b>Factory default</b> <b>Minimum value</b> <b>Maximum value</b> <b>Conversion</b>	238 Profile End Actions Setup x 0 0 4
Parameter 238 can be used to select how the end of the run sequence is accomplished. 0 = Stop - Command Zero Speed 1 = Go to Step, uses P240 to determine which step to proceed to when the end is reached. 2 = TB3 Input, uses P241 to select which TB3 terminal to use. 3 = Compare, uses P242 as the comparison value. 4 = Encoder Home, goes to the home position determined when function enabled.			
<b>239</b>	<b>End Action Speed</b>	<b>Parameter number</b> <b>File:group</b> <b>Parameter type</b> <b>Display</b> <b>Factory default</b> <b>Minimum value</b> <b>Maximum value</b> <b>Conversion</b>	239 Profile End Actions Setup +/- x.x rpm +0.0 rpm -8 x base speed +8 x base speed 4096 = base speed
Parameter 239 sets the speed for the end action. 4096 = Base Speed			



<b>240</b>	<b>End Action Go To</b>	<b>Parameter number</b>	240
	Parameter 240 sets the step to proceed to when P238 = 1	<b>File:group</b>	Profile End Actions
		<b>Parameter type</b>	Setup
		<b>Display</b>	x Step#
		<b>Factory default</b>	1
		<b>Minimum value</b>	0
		<b>Maximum value</b>	16
		<b>Conversion</b>	None
<b>241</b>	<b>End Action Input</b>	<b>Parameter number</b>	241
	Parameter 241 selects the TB3 terminal used when P238 = 2	<b>File:group</b>	Profile End Actions
	Mode 31	<b>Parameter type</b>	Setup
	Mode 32	<b>Display</b>	x
	0 = TB3-22	<b>Factory default</b>	0
	1 = TB3-23	<b>Minimum value</b>	0
	2 = TB3-19	<b>Maximum value</b>	5
	3 = TB3-26	<b>Conversion</b>	None
	4 = TB3-27		
	5 = TB3-28		
	6 = Reserved		
<b>242</b>	<b>End Action Comp</b>	<b>Parameter number</b>	242
	Parameter 242 sets the parameter used as a comparison value to compare against EA value P243. The compare EA is selected by setting P238 = 3	<b>File:group</b>	Profile End Actions
		<b>Parameter type</b>	Setup
		<b>Display</b>	x
		<b>Factory default</b>	1
		<b>Minimum value</b>	1
		<b>Maximum value</b>	296
		<b>Conversion</b>	None
<b>243</b>	<b>End Action Value</b>	<b>Parameter number</b>	243
	Parameter 243 is used when end action is set to "compare"	<b>File:group</b>	Profile End Actions
	This is the value the parameter selected in P242 will be compared against to determine the end of the profile sequence.	<b>Parameter type</b>	Setup
		<b>Display</b>	x
		<b>Factory default</b>	0
		<b>Minimum value</b>	-32767
		<b>Maximum value</b>	32767
		<b>Conversion</b>	None
<b>244</b>	<b>Value Tolerance</b>	<b>Parameter number</b>	244
	Sets the tolerance window for an End of Step signal at each step programmed with an encoder step.	<b>File:group</b>	Profile Commands
		<b>Parameter type</b>	Setup
		<b>Display</b>	x Encoder Pulses
		<b>Factory default</b>	20
		<b>Minimum value</b>	0
		<b>Maximum value</b>	32767
		<b>Conversion</b>	
<b>245</b>	<b>Counts per Unit</b>	<b>Parameter number</b>	245
	Parameter 245 is set to 4 times the encoder PPR for one unit to equal one (1.0) revolution.	<b>File:group</b>	Profile Commands
	Counts per unit parameter determines the size of a single encoder step value unit in encoder counts.	<b>Parameter type</b>	Setup
	Refer to Chap. 9, pages 25 & 26 for additional explanation	<b>Display</b>	x. Encoder Pulses
		<b>Factory default</b>	4096
		<b>Minimum value</b>	1
		<b>Maximum value</b>	32767
		<b>Conversion</b>	Encoder pulse/4

<b>246</b>	<b>Units Traveled</b> Parameter 246 is a read only parameter that shows the value traveled from the "home" position in encoder units. This parameter may roll over if the profile travels more than 3276 units in one direction.	<b>Parameter number</b>	246
		<b>File:group</b>	Profile Command
		<b>Parameter type</b>	Setup
		<b>Display</b>	x.x units
		<b>Factory default</b>	4096
		<b>Minimum value</b>	-3276.7
		<b>Maximum value</b>	3276.7
		<b>Conversion</b>	10 = 1.0 unit
		<b>Conversion</b>	10 = 1.0 unit
<b>247</b>	<b>Profile CMD LSW</b> Parameter 247 is the lower word of the 32-bit speed reference. This must be linked to P28 [Speed Ref 1 Frac].	<b>Parameter number</b>	247
		<b>File:group</b>	Profile Command
		<b>Parameter type</b>	Setup
		<b>Display</b>	+/- x.x rpm
		<b>Factory default</b>	+0.0 rpm
		<b>Minimum value</b>	-8 x base speed
		<b>Maximum value</b>	+8 x base speed
		<b>Conversion</b>	4096 = base motor speed
		<b>Conversion</b>	4096 = base motor speed
<b>248</b>	<b>Profile CMD MSW</b> Parameter 248 is the upper word of the 32-bit speed reference. This must be linked to P29 [Speed Ref 1].	<b>Parameter number</b>	248
		<b>File:group</b>	Profile Command
		<b>Parameter type</b>	Setup
		<b>Display</b>	+/- x.x rpm
		<b>Factory default</b>	+0.0 rpm
		<b>Minimum value</b>	-8 x base speed
		<b>Maximum value</b>	+8 x base speed
		<b>Conversion</b>	4096 = base motor speed
		<b>Conversion</b>	4096 = base motor speed
<b>249</b>	<b>Step 1 Speed</b> Parameter 249 sets the rpm value for this step. (Scaling: 4096 = Base Speed)	<b>Parameter number</b>	249
		<b>File:group</b>	Profile Test Data
		<b>Parameter type</b>	Setup
		<b>Display</b>	+/- x.x rpm
		<b>Factory default</b>	+0.0 rpm
		<b>Minimum value</b>	-8 x base speed
		<b>Maximum value</b>	+8 x base speed
		<b>Conversion</b>	4096 = Base Motor Speed
		<b>Conversion</b>	4096 = Base Motor Speed
<b>250</b>	<b>Step 1 Value</b> Parameter 250 sets the time in seconds for time steps, the counts in units for encoder steps, or the TB3 input to trigger on for TB Input steps. Scaling: Time Step: 10 x desired value (10 = 1.0 sec) Encoder Step: 10 = 1.0 units TB Input Step: dependent on [L Option Mode Sel]. See P241.	<b>Parameter number</b>	250
		<b>File:group</b>	Profile Test Data
		<b>Parameter type</b>	Setup
		<b>Display</b>	x.xS, x, x.x units
		<b>Factory default</b>	0.0,0, 0.0
		<b>Minimum value</b>	0.0,0, 0.0
		<b>Maximum value</b>	3276.7, 5, 3276.7
		<b>Conversion</b>	0=1.0 sec., x TBin, 10 = 1.0 unit
		<b>Conversion</b>	0=1.0 sec., x TBin, 10 = 1.0 unit
<b>251</b>	<b>Step 1 Type</b> Parameter 251 selects the type of step to be used 0 = Not Used (this forces an End Action) 1 = Time Step, operate at speed shown in P249 for time in P250. 2 = TB3 Input Step, operate at speed shown in P249 until P250 input goes true. 3 = Encoder Step, operate at speed shown in P249 for units in P250.	<b>Parameter number</b>	251
		<b>File:group</b>	Profile Test Data
		<b>Parameter type</b>	Setup
		<b>Display</b>	x
		<b>Factory default</b>	0
		<b>Minimum value</b>	0
		<b>Maximum value</b>	3
		<b>Conversion</b>	None
		<b>Conversion</b>	None

<b>252</b>	<b>Step 2 Speed</b>	<b>Parameter number</b>	252
	Parameter 252 sets the rpm value for this step. (Scaling: 4096 = Base Speed)	<b>File:group</b>	Profile Test Data
		<b>Parameter type</b>	Setup
		<b>Display</b>	+/- x.x rpm
		<b>Factory default</b>	+0.0 rpm
		<b>Minimum value</b>	-8 x base speed
		<b>Maximum value</b>	+8 x base speed
		<b>Conversion</b>	4096 = Base Motor Speed
<b>253</b>	<b>Step 2 Value</b>	<b>Parameter number</b>	253
	Parameter 253 sets the time in seconds for time steps, the counts in units for encoder steps, and the TB3 input to trigger on for TB Input steps. Scaling:	<b>File:group</b>	Profile Test Data
	Time Step: 10 x desired value (10 = 1.0 sec)	<b>Parameter type</b>	Setup
	Encoder Step: 10 = 1.0 unit	<b>Display</b>	x.xS, x, x.x units
	TB Input Step: dependent on [L Option Mode Sel]. See P241.	<b>Factory default</b>	0.0,0, 0.0
		<b>Minimum value</b>	0.0,0, 0.0
		<b>Maximum value</b>	3276.7, 5, 3276.7
		<b>Conversion</b>	0=1.0 sec., x TBin, 10 = 1.0 unit
<b>254</b>	<b>Step 2 Type</b>	<b>Parameter number</b>	254
	Parameter 251 selects the type of step to be used	<b>File:group</b>	Profile Test Data
	0 = Not Used (This forces an End Action)	<b>Parameter type</b>	Setup
	1 = Time Step, operate at speed shown in P252 for time in P253.	<b>Display</b>	x
	2 = TB3 Input Step, operate at speed shown in P252 until this input goes true.	<b>Factory default</b>	0
	3 = Encoder Step, operate at speed shown in P252 for units in P253.	<b>Minimum value</b>	0
		<b>Maximum value</b>	3
		<b>Conversion</b>	None
<b>255</b>	<b>Step 3 Speed</b>	<b>Parameter number</b>	255
	Parameter 255 sets the rpm value for this step. (Scaling: 4096 = Base Speed)	<b>File:group</b>	Profile Test Data
		<b>Parameter type</b>	Setup
		<b>Display</b>	+/- x.x rpm
		<b>Factory default</b>	+0.0 rpm
		<b>Minimum value</b>	-8 x base speed
		<b>Maximum value</b>	+8 x base speed
		<b>Conversion</b>	4096 = Base Motor Speed
<b>256</b>	<b>Step 3 Value</b>	<b>Parameter number</b>	256
	Parameter 256 sets the time in seconds for time steps, the counts in units for encoder steps, and the TB3 input to trigger on for TB Input steps. Scaling:	<b>File:group</b>	Profile Test Data
	Time Step: 10 x desired value (10 = 1.0 sec)	<b>Parameter type</b>	Setup
	Encoder Step: 10 = 1.0 units	<b>Display</b>	x.xS, x, x.x units
	TB Input Step: dependent on [L Option Mode Sel]. See P241.	<b>Factory default</b>	0.0,0, 0.0
		<b>Minimum value</b>	0.0,0, 0.0
		<b>Maximum value</b>	3276.7, 5, 3276.7
		<b>Conversion</b>	0=1.0 sec., x TBin, 10 = 1 unit
<b>257</b>	<b>Step 3 Type</b>	<b>Parameter number</b>	257
	Parameter 257 selects the type of step to be used	<b>File:group</b>	Profile Test Data
	0 = Not Used (This forces an End Action)	<b>Parameter type</b>	Setup
	1 = Time Step, operate at speed shown in P255 for time in P256.	<b>Display</b>	x
	2 = TB3 Input Step, operate at speed shown in P255 until this input goes true.	<b>Factory default</b>	0
	3 = Encoder Step, operate at speed shown in P255 for units in P256.	<b>Minimum value</b>	0
		<b>Maximum value</b>	3
		<b>Conversion</b>	None

<b>258</b>	<b>Step 4 Speed</b>	<b>Parameter number</b>	258
	Parameter 258 sets the rpm value for this step. (Scaling: 4096 = Base Speed)	<b>File:group</b>	Profile Test Data
		<b>Parameter type</b>	Setup
		<b>Display</b>	+/- x.x rpm
		<b>Factory default</b>	+0.0 rpm
		<b>Minimum value</b>	-8 x base speed
		<b>Maximum value</b>	+8 x base speed
		<b>Conversion</b>	4096 = Base Motor Speed
<b>259</b>	<b>Step 4 Value</b>	<b>Parameter number</b>	259
	Parameter 259 sets the time in seconds for time steps, the counts in units for encoder steps, and the TB3 input to trigger on for TB Input steps. Scaling:	<b>File:group</b>	Profile Test Data
	Time Step: 10 x desired value (10 = 1.0 sec)	<b>Parameter type</b>	Setup
	Encoder Step: 10 = 1.0 units	<b>Display</b>	x.xS, x, x.x units
	TB Input Step: dependent on [L Option Mode Sel]. See P241.	<b>Factory default</b>	0.0,0, 0.0
		<b>Minimum value</b>	0.0,0, 0.0
		<b>Maximum value</b>	3276.7, 5, 3276.7
		<b>Conversion</b>	0=1.0 sec., x TBin, 10 = 1 unit
<b>260</b>	<b>Step 4 Type</b>	<b>Parameter number</b>	260
	Parameter 260 selects the type of step to be used	<b>File:group</b>	Profile Test Data
	0 = Not Used (This forces an End Action)	<b>Parameter type</b>	Setup
	1 = Time Step, operate at speed shown in P258 for time in P259.	<b>Display</b>	x
	2 = TB3 Input Step, operate at speed shown in P258 until this input goes true.	<b>Factory default</b>	0
	3 = Encoder Step, operate at speed shown in P258 for units in P259.	<b>Minimum value</b>	0
		<b>Maximum value</b>	3
		<b>Conversion</b>	
<b>261</b>	<b>Step 5 Speed</b>	<b>Parameter number</b>	261
	Parameter 261 sets the rpm value for this step. (Scaling: 4096 = Base Speed)	<b>File:group</b>	Profile Test Data
		<b>Parameter type</b>	Setup
		<b>Display</b>	+/- x.x rpm
		<b>Factory default</b>	+0.0 rpm
		<b>Minimum value</b>	-8 x base speed
		<b>Maximum value</b>	+8 x base speed
		<b>Conversion</b>	4096 = Base Motor Speed
<b>262</b>	<b>Step 5 Value</b>	<b>Parameter number</b>	262
	Parameter 262 sets the time in seconds for time steps, the counts in units for encoder steps, and the TB3 input to trigger on for TB Input steps. Scaling:	<b>File:group</b>	Profile Test Data
	Time Step: 10 x desired value (10 = 1.0 sec)	<b>Parameter type</b>	Setup
	Encoder Step: 1 = 1 revolution	<b>Display</b>	x.xS, x, x.x units
	TB Input Step: dependent on [L Option Mode Sel]. See P241.	<b>Factory default</b>	0.0,0, 0.0
		<b>Minimum value</b>	0.0,0, 0.0
		<b>Maximum value</b>	3276.7, 5, 3276.7
		<b>Conversion</b>	0=1.0 sec., x TBin, 10 = 1 unit
<b>263</b>	<b>Step 5 Type</b>	<b>Parameter number</b>	263
	Parameter 263 selects the type of step to be used	<b>File:group</b>	Profile Test Data
	0 = Not Used (This forces an End Action)	<b>Parameter type</b>	Setup
	1 = Time Step, operate at speed shown in P261 for time in P262.	<b>Display</b>	x
	2 = TB3 Input Step, operate at speed shown in P261 until P262 input goes true.	<b>Factory default</b>	0
	3 = Encoder Step, operate at speed shown in P261 for units in P262.	<b>Minimum value</b>	0
		<b>Maximum value</b>	3
		<b>Conversion</b>	

<b>264</b>	<b>Step 6 Speed</b>	<b>Parameter number</b>	264
	Parameter 264 sets the rpm value for this step. (Scaling: 4096 = Base Speed)	<b>File:group</b>	Profile Test Data
		<b>Parameter type</b>	Setup
		<b>Display</b>	+/- x.x rpm
		<b>Factory default</b>	+0.0 rpm
		<b>Minimum value</b>	-8 x base speed
		<b>Maximum value</b>	+8 x base speed
		<b>Conversion</b>	4096 = Base Motor Speed
<b>265</b>	<b>Step 6 Value</b>	<b>Parameter number</b>	265
	Parameter 265 sets the time in seconds for time steps, the counts in units for encoder steps, and the TB3 input to trigger on for TB Input steps. Scaling:	<b>File:group</b>	Profile Test Data
	Time Step: 10 x desired value (10 = 1.0 sec)	<b>Parameter type</b>	Setup
	Encoder Step: 10 = 1.0 units	<b>Display</b>	x.xS, x, x.x units
	TB Input Step: dependent on [L Option Mode Sel]. See P241	<b>Factory default</b>	0.0,0, 0.0
		<b>Minimum value</b>	0.0,0, 0.0
		<b>Maximum value</b>	3276.7, 5, 3276.7
		<b>Conversion</b>	0=1.0 sec., x TBin, 10 = 1 unit
<b>266</b>	<b>Step 6 Type</b>	<b>Parameter number</b>	266
	Parameter 266 selects the type of step to be used	<b>File:group</b>	Profile Test Data
	0 = Not Used (This forces an End Action)	<b>Parameter type</b>	Setup
	1 = Time Step, operate at speed shown in P264 for time in P265.	<b>Display</b>	x
	2 = TB3 Input Step, operate at speed shown in P264 until this input goes true.	<b>Factory default</b>	0
	3 = Encoder Step, operate at speed shown in P264 for units in P265.	<b>Minimum value</b>	0
		<b>Maximum value</b>	3
		<b>Conversion</b>	
<b>267</b>	<b>Step 7 Speed</b>	<b>Parameter number</b>	267
	Parameter 267 sets the rpm value for this step. (Scaling: 4096 = Base Speed)	<b>File:group</b>	Profile Test Data
		<b>Parameter type</b>	Setup
		<b>Display</b>	+/- x.x rpm
		<b>Factory default</b>	+0.0 rpm
		<b>Minimum value</b>	-8 x base speed
		<b>Maximum value</b>	+8 x base speed
		<b>Conversion</b>	4096 = Base Motor Speed
<b>268</b>	<b>Step 7 Value</b>	<b>Parameter number</b>	268
	Parameter 268 sets the time in seconds for time steps, the counts in units for encoder steps, and the TB3 input to trigger on for TB Input steps. Scaling:	<b>File:group</b>	Profile Test Data
	Time Step: 10 x desired value (10 = 1.0 sec)	<b>Parameter type</b>	Setup
	Encoder Step: 10 = 1.0 units	<b>Display</b>	x.xS, x, x.x units
	TB Input Step: dependent on [L Option Mode Sel] See P241.	<b>Factory default</b>	0.0,0, 0.0
		<b>Minimum value</b>	0.0,0, 0.0
		<b>Maximum value</b>	3276.7, 5, 3276.7
		<b>Conversion</b>	10=1.0 sec., x TBin, 10 = 1 unit
<b>269</b>	<b>Step 7 Type</b>	<b>Parameter number</b>	269
	Parameter 269 selects the type of step to be used	<b>File:group</b>	Profile Test Data
	0 = Not Used (This forces an End Action)	<b>Parameter type</b>	Setup
	1 = Time Step, operate at speed shown in P267 for time in P268.	<b>Display</b>	x
	2 = TB3 Input Step, operate at speed shown in P267 until this input goes true.	<b>Factory default</b>	0
	3 = Encoder Step, operate at speed shown in P267 for units in P268.	<b>Minimum value</b>	0
		<b>Maximum value</b>	3
		<b>Conversion</b>	

<b>270</b>	<b>Step 8 Speed</b>	<b>Parameter number</b>	270
	Parameter 270 sets the rpm value for this step. (Scaling: 4096 = Base Speed)	<b>File:group</b>	Profile Test Data
		<b>Parameter type</b>	Setup
		<b>Display</b>	+/- x.x rpm
		<b>Factory default</b>	+0.0 rpm
		<b>Minimum value</b>	-8 x base speed
		<b>Maximum value</b>	+8 x base speed
		<b>Conversion</b>	4096 = Base Motor Speed
<b>271</b>	<b>Step 8 Value</b>	<b>Parameter number</b>	271
	Parameter 271 sets the time in seconds for time steps, the counts in units for encoder steps, and the TB3 input to trigger on for TB Input steps. Scaling:	<b>File:group</b>	Profile Test Data
	Time Step: 10 x desired value (10 = 1.0 sec)	<b>Parameter type</b>	Setup
	Encoder Step: 10 = 1.0 units	<b>Display</b>	x.xS, x, x.x units
	TB Input Step: dependent on [L Option Mode Sel]. See P241	<b>Factory default</b>	0.0,0, 0.0
		<b>Minimum value</b>	0.0,0, 0.0
		<b>Maximum value</b>	3276.7, 5, 3276.7
		<b>Conversion</b>	10=1.0 sec., x TBIn, 10 = 1 unit
<b>272</b>	<b>Step 8 Type</b>	<b>Parameter number</b>	272
	Parameter 272 selects the type of step to be used	<b>File:group</b>	Profile Test Data
	0 = Not Used (This forces an End Action)	<b>Parameter type</b>	Setup
	1 = Time Step, operate at speed shown in P270 for time in P271.	<b>Display</b>	x
	2 = TB3 Input Step, operate at speed shown in P270 until this input goes true.	<b>Factory default</b>	0
	3 = Encoder Step, operate at speed shown in P270 for units in P271.	<b>Minimum value</b>	0
		<b>Maximum value</b>	3
		<b>Conversion</b>	
<b>273</b>	<b>Step 9 Speed</b>	<b>Parameter number</b>	273
	Parameter 273 sets the rpm value for this step. (Scaling: 4096 = Base Speed)	<b>File:group</b>	Profile Test Data
		<b>Parameter type</b>	Setup
		<b>Display</b>	+/- x.x rpm
		<b>Factory default</b>	+0.0 rpm
		<b>Minimum value</b>	-8 x base speed
		<b>Maximum value</b>	+8 x base speed
		<b>Conversion</b>	4096 = Base Motor Speed
<b>274</b>	<b>Step 9 Value</b>	<b>Parameter number</b>	274
	Parameter 274 sets the time in seconds for time steps, the counts in units for encoder steps, and the TB3 input to trigger on for TB Input steps. Scaling:	<b>File:group</b>	Profile Test Data
	Time Step: 10 x desired value (10 = 1.0 sec)	<b>Parameter type</b>	Setup
	Encoder Step: 10 = 1.0 units	<b>Display</b>	x.xS, x, x.x units
	TB Input Step: dependent on [L Option Mode Sel]. See P241	<b>Factory default</b>	0.0,0, 0.0
		<b>Minimum value</b>	0.0,0, 0.0
		<b>Maximum value</b>	3276.7, 5, 3276.7
		<b>Conversion</b>	10=1.0 sec., x TBIn, 10 = 1 unit
<b>275</b>	<b>Step 9 Type</b>	<b>Parameter number</b>	275
	Parameter 275 selects the type of step to be used	<b>File:group</b>	Profile Test Data
	0 = Not Used (This forces an End Action)	<b>Parameter type</b>	Setup
	1 = Time Step, operate at speed shown in P273 for time in P274.	<b>Display</b>	x
	2 = TB3 Input Step, operate at speed shown in P273 until this input goes true.	<b>Factory default</b>	0
	3 = Encoder Step, operate at speed shown in P273 for units in P274.	<b>Minimum value</b>	0
		<b>Maximum value</b>	3
		<b>Conversion</b>	

<b>276</b>	<b>Step 10 Speed</b>	<b>Parameter number</b>	276
	Parameter 276 sets the rpm value for this step. (Scaling: 4096 = Base Speed)	<b>File:group</b>	Profile Test Data
		<b>Parameter type</b>	Setup
		<b>Display</b>	+/- x.x rpm
		<b>Factory default</b>	0.00 rpm
		<b>Minimum value</b>	-8 x base speed
		<b>Maximum value</b>	+8 x base speed
		<b>Conversion</b>	
<b>277</b>	<b>Step 10 Value</b>	<b>Parameter number</b>	277
	Parameter 277 sets the time in seconds for time steps, the counts in units for encoder steps, and the TB3 input to trigger on for TB Input steps. Scaling:	<b>File:group</b>	Profile Test Data
	Time Step: 10 x desired value (10 = 1.0 sec)	<b>Parameter type</b>	Setup
	Encoder Step: 10 = 1.0 units	<b>Display</b>	x.xS, x, x.x units
	TB Input Step: dependent on [L Option Mode Sel] See P241	<b>Factory default</b>	0.0,0, 0.0
		<b>Minimum value</b>	0.0,0, 0.0
		<b>Maximum value</b>	3276.7, 5, 3276.7
		<b>Conversion</b>	10=1.0 sec., x TBin, 10 = 1 unit
<b>278</b>	<b>Step 10 Type</b>	<b>Parameter number</b>	278
	Parameter 278 selects the type of step to be used	<b>File:group</b>	Profile Test Data
	0 = Not Used (This forces an End Action)	<b>Parameter type</b>	Setup
	1 = Time Step, operate at speed shown in P276 for time in P277.	<b>Display</b>	x
	2 = TB3 Input Step, operate at speed shown in P276 until this input goes true. See P241.	<b>Factory default</b>	0
	3 = Encoder Step, operate at speed shown in P276 for units in P277.	<b>Minimum value</b>	0
		<b>Maximum value</b>	3
		<b>Conversion</b>	
<b>279</b>	<b>Step 11 Speed</b>	<b>Parameter number</b>	279
	Parameter 279 sets the rpm value for this step. (Scaling: 4096 = Base Speed)	<b>File:group</b>	Profile Test Data
		<b>Parameter type</b>	Setup
		<b>Display</b>	+/- x.x rpm
		<b>Factory default</b>	0.00 rpm
		<b>Minimum value</b>	-8 x base speed
		<b>Maximum value</b>	+8 x base speed
		<b>Conversion</b>	4096 = base sp
<b>280</b>	<b>Step 11 Value</b>	<b>Parameter number</b>	280
	Parameter 280 sets the time in seconds for time steps, the counts in units for encoder steps, and the TB3 input to trigger on for TB Input steps. Scaling:	<b>File:group</b>	Profile Test Data
	Time Step: 10 x desired value (10 = 1.0 sec)	<b>Parameter type</b>	Setup
	Encoder Step: 10 = 1.0 units	<b>Display</b>	x.xS, x, x.x units
	TB Input Step: dependent on [L Option Mode Sel]. See P241	<b>Factory default</b>	0.0,0, 0.0
		<b>Minimum value</b>	0.0,0, 0.0
		<b>Maximum value</b>	3276.7, 5, 3276.7
		<b>Conversion</b>	10=1.0 sec., x TBin, 10 = 1 unit
<b>281</b>	<b>Step 11 Type</b>	<b>Parameter number</b>	281
	Parameter 281 selects the type of step to be used	<b>File:group</b>	Profile Test Data
	0 = Not Used (This forces an End Action)	<b>Parameter type</b>	Setup
	1 = Time Step, operate at speed shown in P279 for time in P280.	<b>Display</b>	x
	2 = TB3 Input Step, operate at speed shown in P279 until this input goes true.	<b>Factory default</b>	0
	3 = Encoder Step, operate at speed shown in P279 for units in P280.	<b>Minimum value</b>	0
		<b>Maximum value</b>	3
		<b>Conversion</b>	

<b>282</b>	<b>Step 12 Speed</b>	<b>Parameter number</b>	282
	Parameter 282 sets the rpm value for this step. (Scaling: 4096 = Base Speed)	<b>File:group</b>	Profile Test Data
		<b>Parameter type</b>	Setup
		<b>Display</b>	+/- x.x rpm
		<b>Factory default</b>	+0.00 rpm
		<b>Minimum value</b>	-8 x base speed
		<b>Maximum value</b>	+8 x base speed
		<b>Conversion</b>	4096 = base sp
<b>283</b>	<b>Step 12 Value</b>	<b>Parameter number</b>	283
	Parameter 283 sets the time in seconds for time steps, the counts in units for encoder steps, and the TB3 input to trigger on for TB Input steps. Scaling:	<b>File:group</b>	Profile Test Data
	Time Step: 10 x desired value (10 = 1.0 sec)	<b>Parameter type</b>	Setup
	Encoder Step: 10 = 1.0 units	<b>Display</b>	x.xS, x, x.x units
	TB Input Step: dependent on [L Option Mode Se Sel] See P241.	<b>Factory default</b>	0.0,0, 0.0
		<b>Minimum value</b>	0.0,0, 0.0
		<b>Maximum value</b>	3276.7, 5, 3276.7
		<b>Conversion</b>	10=1.0 sec., x TBIn, 10 = 1 unit
<b>284</b>	<b>Step 12 Type</b>	<b>Parameter number</b>	284
	Parameter 284 selects the type of step to be used	<b>File:group</b>	Profile Test Data
	0 = Not Used (This forces an End Action)	<b>Parameter type</b>	Setup
	1 = Time Step, operate at speed shown in P282 for time in P283.	<b>Display</b>	x
	2 = TB3 Input Step, operate at speed shown in P282 until this input goes true.	<b>Factory default</b>	0
	3 = Encoder Step, operate at speed shown in P282 for units in P283.	<b>Minimum value</b>	0
		<b>Maximum value</b>	3
		<b>Conversion</b>	
<b>285</b>	<b>Step 13 Speed</b>	<b>Parameter number</b>	285
	Parameter 285 sets the rpm value for this step. (Scaling: 4096 = Base Speed)	<b>File:group</b>	Profile Test Data
		<b>Parameter type</b>	Setup
		<b>Display</b>	+/- x.x rpm
		<b>Factory default</b>	+0.00 rpm
		<b>Minimum value</b>	-8 x base speed
		<b>Maximum value</b>	+8 x base speed
		<b>Conversion</b>	4096 = base sp
<b>286</b>	<b>Step 13 Value</b>	<b>Parameter number</b>	286
	Parameter 286 sets the time in seconds for time steps, the counts in units for encoder steps, and the TB3 input to trigger on for TB Input steps. Scaling:	<b>File:group</b>	Profile Test Data
	Time Step: 10 x desired value (10 = 1.0 sec)	<b>Parameter type</b>	Setup
	Encoder Step: 10 = 1.0 units	<b>Display</b>	x.xS, x, x.x units
	TB Input Step: dependent on [L Option Mode Sel]. See P241	<b>Factory default</b>	0.0,0, 0.0
		<b>Minimum value</b>	0.0,0, 0.0
		<b>Maximum value</b>	3276.7, 5, 3276.7
		<b>Conversion</b>	10=1.0 sec., x TBIn, 10 = 1 unit
<b>287</b>	<b>Step 13 Type</b>	<b>Parameter number</b>	287
	Parameter 287 selects the type of step to be used	<b>File:group</b>	Profile Test Data
	0 = Not Used (This forces an End Action)	<b>Parameter type</b>	Setup
	1 = Time Step, operate at speed shown in P285 for time in P286.	<b>Display</b>	x
	2 = TB3 Input Step, operate at speed shown in P285 until this input goes true.	<b>Factory default</b>	0
	3 = Encoder Step, operate at speed shown in P285 for units in P286.	<b>Minimum value</b>	0
		<b>Maximum value</b>	3
		<b>Conversion</b>	



<b>288</b>	<b>Step 14 Speed</b>	<b>Parameter number</b>	288
	Parameter 288 sets the rpm value for this step. (Scaling: 4096 = Base Speed)	<b>File:group</b>	Profile Test Data
		<b>Parameter type</b>	Setup
		<b>Display</b>	+/- x.x rpm
		<b>Factory default</b>	+0.0 rpm
		<b>Minimum value</b>	-8 x base sp
		<b>Maximum value</b>	+8 x base sp
		<b>Conversion</b>	4096 = base sp
<b>289</b>	<b>Step 14 Value</b>	<b>Parameter number</b>	289
	Parameter 289 sets the time in seconds for time steps, the counts in units for encoder steps, and the TB3 input to trigger on for TB Input steps. Scaling:	<b>File:group</b>	Profile Test Data
	Time Step: 10 x desired value (10 = 1.0 sec)	<b>Parameter type</b>	Setup
	Encoder Step: 10 = 1.0 units	<b>Display</b>	x.xS, x, x.x units
	TB Input Step: dependent on [L Option Mode Sel]. See P241	<b>Factory default</b>	0.0,0, 0.0
		<b>Minimum value</b>	0.0,0, 0.0
		<b>Maximum value</b>	3276.7, 5, 3276.7
		<b>Conversion</b>	10=1.0 sec., x TBin, 10 = 1 unit
<b>290</b>	<b>Step 14 Type</b>	<b>Parameter number</b>	290
	Parameter 290 selects the type of step to be used	<b>File:group</b>	Profile Test Data
	0 = Not Used (This forces an End Action)	<b>Parameter type</b>	Setup
	1 = Time Step, operate at speed shown in P288 for time in P289.	<b>Display</b>	x
	2 = TB3 Input Step, operate at speed shown in P288 until this input goes true.	<b>Factory default</b>	0
	3 = Encoder Step, operate at speed shown in P288 for units in P289.	<b>Minimum value</b>	0
		<b>Maximum value</b>	3
		<b>Conversion</b>	None
<b>291</b>	<b>Step 15 Speed</b>	<b>Parameter number</b>	291
	Parameter 291 sets the rpm value for this step. (Scaling: 4096 = Base Speed)	<b>File:group</b>	Profile Test Data
		<b>Parameter type</b>	Setup
		<b>Display</b>	+/- x.x rpm
		<b>Factory default</b>	+0.0 rpm
		<b>Minimum value</b>	-8 x base sp
		<b>Maximum value</b>	+8 x base sp
		<b>Conversion</b>	4096 = base sp
<b>292</b>	<b>Step 15 Value</b>	<b>Parameter number</b>	292
	Parameter 292 sets the time in seconds for time steps, the counts in units for encoder steps, and the TB3 input to trigger on for TB Input steps. Scaling:	<b>File:group</b>	Profile Test Data
	Time Step: 10 x desired value (10 = 1.0 sec)	<b>Parameter type</b>	Setup
	Encoder Step: 10 = 1.0 units	<b>Display</b>	x.xS, x, x.x units
	TB Input Step: dependent on [L Option Mode Sel]. See P241.	<b>Factory default</b>	0.0,0, 0.0
		<b>Minimum value</b>	0.0,0, 0.0
		<b>Maximum value</b>	3276.7, 5, 3276.7
		<b>Conversion</b>	10=1.0 sec., x TBin, 10 = 1 unit
<b>293</b>	<b>Step 15 Type</b>	<b>Parameter number</b>	293
	Parameter 293 selects the type of step to be used	<b>File:group</b>	Profile Test Data
	0 = Not Used (This forces an End Action)	<b>Parameter type</b>	Setup
	1 = Time Step, operate at speed shown in P291 for time in P292.	<b>Display</b>	x
	2 = TB3 Input Step, operate at speed shown in P291 until this input goes true.	<b>Factory default</b>	0
	3 = Encoder Step, operate at speed shown in P291 for units in P292.	<b>Minimum value</b>	0
		<b>Maximum value</b>	3
		<b>Conversion</b>	None

<b>294</b>	<b>Step 16 Speed</b> Parameter 294 sets the rpm value for this step. (Scaling: 4096 = Base Speed)	<b>Parameter number</b>	294
		<b>File:group</b>	Profile Test Data
		<b>Parameter type</b>	Setup
		<b>Display</b>	rpm
		<b>Factory default</b>	+0.0 rpm
		<b>Minimum value</b>	-8 x base sp
		<b>Maximum value</b>	+8 x base sp
	<b>Conversion</b>	4096 = base motor speed	
<b>295</b>	<b>Step 16 Value</b> Parameter 295 sets the time in seconds for time steps, the counts in units for encoder steps, and the TB3 input to trigger on for TB Input steps. Scaling: Time Step: 10 x desired value (10 = 1.0 sec) Encoder Step: 10 =1.0 units TB Input Step: dependent on [L Option Mode Sel]. See P241	<b>Parameter number</b>	295
		<b>File:group</b>	Profile Test Data
		<b>Parameter type</b>	Setup
		<b>Display</b>	x.xS, x, x.x units
		<b>Factory default</b>	0.0, 0, 0.0
		<b>Minimum value</b>	0.0, 0,0.0
		<b>Maximum value</b>	3276.7, 5, 32767.7
	<b>Conversion</b>	10=1.0 sec., xTBIn, 10 = 1 unit	
<b>296</b>	<b>Step 16 Type</b> Parameter 296 selects the type of step to be used 0 = Not Used (This forces an End Action) 1 = Time Step, operate at speed shown in P294 for time in P295. 2 = TB3 Input Step, operate at speed shown in P294 until this input goes true. 3 = Encoder Step, operate at speed shown in P294 for units in P295.	<b>Parameter number</b>	296
		<b>File:group</b>	Profile Test Data
		<b>Parameter type</b>	Setup
		<b>Display</b>	x
		<b>Factory default</b>	0
		<b>Minimum value</b>	0
		<b>Maximum value</b>	3
	<b>Conversion</b>		

## Troubleshooting

### Chapter Objectives

Chapter 12 provides information to help troubleshoot your 1336 IMPACT drive.

This topic:	Starts on page:
Required equipment	12-1
Fault/warning handling	12-2
Viewing the queues and timestamps on the HIM	12-6
Fault descriptions	12-7
Bus precharge and ridethrough descriptions	12-16
Understanding the bus voltage tracker	12-21
Understanding the parameter limit faults	12-22
Understanding the math limit faults	12-24
Start up troubleshooting procedures	12-27
Miscellaneous troubleshooting procedures	12-28
Encoderless troubleshooting procedures	12-30



**ATTENTION:** Do not troubleshoot or maintain the 1336 IMPACT drive unless you are familiar with your drive system and the associated machinery. You may be injured and/or the equipment may be damaged if you do not comply.

During the start-up procedure, you should have recorded board jumper settings for each board, board software version numbers, and the drive and motor nameplate data in Table 6.A. If this information was not recorded, record it before beginning any troubleshooting sequences.

### Required Equipment

For initial troubleshooting, you need a programming device to read fault codes. You should also have the following equipment available before starting any troubleshooting procedures:

- digital multimeter (DMM) capable of 1000V DC/750V AC, with one megohm minimum input impedance
- clamp on ammeter (AC/DC) with current ratings to 2X rated current output of the 1336 IMPACT AC drive
- dual trace oscilloscope with differential capability, digital storage, two X10 and one X100 calibrated probes (optional but recommended)



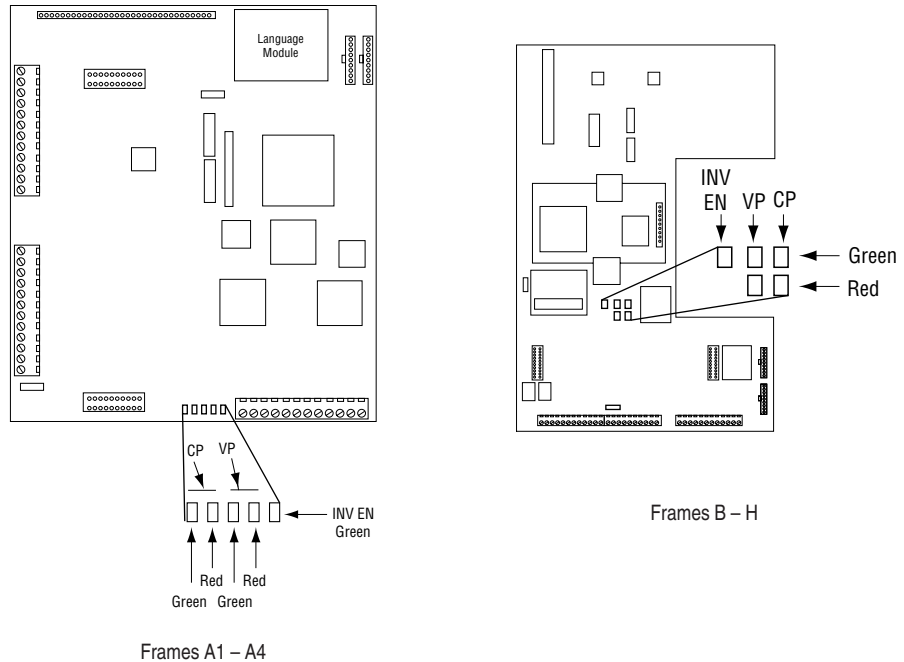
**ATTENTION:** Potentially fatal voltages may result from improperly using an oscilloscope and other test equipment. The oscilloscope chassis may be at potentially fatal voltage if not properly grounded. Allen-Bradley does not recommend using an oscilloscope to directly measure high voltages. Use an isolated measuring device with a high voltage probe. Contact Allen-Bradley for recommendations.

- hand tachometer used to monitor motor speeds
- programming device instruction manual

### Fault/Warning Handling

When a problem occurs with your drive, check the VP and CP lights on your drive. Figure 12.1 shows the location of the VP and CP lights.

**Figure 12.1**  
**VP and CP LED Locations**



The lights on the motor control board indicate the status of the velocity processor (VP) and current processor (CP):

<b>If the VP or CP LED is:</b>	<b>Then, for that processor:</b>
Solid green	No fault occurred.
Flashing green	A drive warning occurred.
Flashing red	A drive soft fault occurred.
Solid red	A drive hard fault occurred.

Faults fall into three basic categories:

This type of fault:	Has the following definition:	To remove this fault, you need to:
Hard	Trips the drive causing it to stop. You cannot regain control until you reset the drive.	Perform a <i>Drive Reset</i> command or cycle drive power.
Soft	Trips the drive causing it to stop.	<ol style="list-style-type: none"> <li>1. Address the condition that caused the fault.</li> <li>2. Perform a <i>Clear Faults</i> command.</li> </ol>
Warning	Indicates an undesirable condition. The drive will not stop.	<ol style="list-style-type: none"> <li>1. Address the condition that caused the warning.</li> <li>2. Perform a <i>Clear Faults</i> command.</li> </ol>

Faults are annunciated on the Human Interface Module (HIM) at the time they occur. Warnings are not annunciated on the HIM.

To help troubleshoot your 1336 IMPACT drive, the drive logs any faults or warnings in either the fault or warning queue. The faults and warnings that are contained in the queues are of either a configurable type or a non-configurable type.

This fault type:	Refers to faults that you:
Configurable	Can set up to either trip the drive or provide only a visual warning while the drive continues to operate.
Non-configurable	Cannot disable. These faults are the result of a condition that could damage the drive if allowed to persist.



*You can reset the faults by pressing the stop button on the HIM.*

Several bit-encoded parameters are also available to help troubleshoot your drive. These parameters are covered later in this chapter and in the auto-tuning chapter. When viewing these parameters from a HIM, you should understand how the HIM displays the bits.

When the appropriate parameter is displayed, you will see two rows of 8 bits represented by zeros and ones. The top row contains (from left to right) bits 15 through bit 8, and the bottom row contains bits 7 through bit 0.

To:	Press this key:
Display the enum (text definition) for bit 0	<i>Select</i>
Continue scrolling through the bits	<i>Select</i> for each bit
Return to the parameter	<i>Escape</i>

Refer to Appendix C, *Using the Human Interface Module (HIM)*, for additional information.

## Configuring Faults and Warnings Group 1

You can configure which of the following faults you want to trip the drive by using *Fault Select 1* (parameter 20) and *Warning Select 1* (parameter 21). *Fault Select 1* and *Warning Select 1* both have the following bit definitions:

<i>file:</i> Fault Setup
<i>group:</i> Fault Config

This bit:	With this text:	Is defined as:
0	<b>RidethruTime</b>	A bus ridethrough timeout occurred.
1	<b>Prechrg Time</b>	A precharge timeout occurred.
2	<b>Bus Drop</b>	A bus voltage drop of 150V below the bus tracker voltage. This is covered in detail later in this chapter.
3	<b>Bus Undervit</b>	A bus voltage drop to a level below the value set in <i>Line Undervolts</i> (parameter 27).
4	<b>Bus Cycles&gt;5</b>	More than 5 ridethroughs occurred within a 20 second period.
5	<b>Open Circuit</b>	The fast flux up current is less than 50% of commanded.
8	<b>mA Input</b>	A loss of input connection after it was established.
9	<b>SP 1 Timeout</b>	A communication loss with SCANport device 1.
10	<b>SP 2 Timeout</b>	A communication loss with SCANport device 2.
11	<b>SP 3 Timeout</b>	A communication loss with SCANport device 3.
12	<b>SP 4 Timeout</b>	A communication loss with SCANport device 4.
13	<b>SP 5 Timeout</b>	A communication loss with SCANport device 5.
14	<b>SP 6 Timeout</b>	A communication loss with SCANport device 6.
15	<b>SP Error</b>	Too many errors have occurred in the communications.

Bits 6 and 7 are reserved.

For each condition that you want the drive to fault on, set the corresponding bit in *Fault Select 1*. When the drive trips on a condition that you set to fault the drive, how the drive reacts depends on which condition occurred.

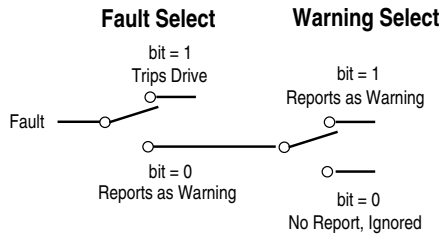
For bits 0 through 5:

- The red CP light turns on.
- The motor coasts to a stop.

For bits 8 through 14:

- The red VP light turns on.
- The motor stops according to how bits 1 – 3 in *Logic Options* (parameter 17) are set.

If this bit is set:	Then this stop type is used:
1	Coast
2	Current limit
3	Ramp



For each condition that you want the drive to display a warning fault on, you need to:

1. Set the corresponding bit in *Warning Select 1*.
2. Make sure the corresponding bit in *Fault Select 1* is set to 0.

When the drive trips on a condition that you set to display a warning:

- The CP light flashes green.
- The drive continues to run.

If a particular bit is not set in either *Fault Select 1* or *Warning Select 1*, the drive ignores the condition when it occurs.

Most of the group 1 fault/warning configuration options deal with DC bus conditions. These bus conditions deal with the bus precharge and any type of ridethrough conditions. The bus precharge and ridethrough conditions are covered later in this chapter.

If you are using bits 9 – 14 to ignore communication errors, please read the following:



**ATTENTION:** Hazard of personal injury or equipment damage exist. If you command a start or jog and then disconnect the programming device, the drive will not fault if you have the SCANport communications fault set to be ignored for that port.

### Configuring Faults and Warnings Group 2

You can configure which of the following faults you want to trip the drive by using *Fault Select 2* (parameter 22) and *Warning Select 2* (parameter 23). *Fault Select 2* and *Warning Select 2* both have the following bit definitions:

This bit:	With this text:	Is defined as:
0	<b>SpdFdbk Loss</b>	A loss of speed feedback information from the digital encoder has occurred.
1	<b>InvOvtmp Pnd</b>	An inverter overtemperature is pending.
3	<b>MtrOvld Pend</b>	A motor overload (I <sup>2</sup> T) is pending.
4	<b>MtrOvld Trip</b>	A motor overload (I <sup>2</sup> T) trip has occurred.
5	<b>Mtr Stall</b>	The motor has stalled.
6	<b>Ext Fault In</b>	An external fault has occurred.
9	<b>Param Limit</b>	A parameter is out of limits.
10	<b>Math Limit</b>	A math limit has occurred.
13	<b>InvOvld Pend</b>	An inverter overload is pending (IT).
15	<b>InvOvld Trp</b>	An inverter overload trip (IT) has occurred.

Bits 2, 7, 8, 11, 12, and 14 are reserved.

For each condition that you want the drive to fault on, you need to set the corresponding bit in *Fault Select 2*. When the drive trips on a condition that you set to fault the drive, how the drive reacts depends on which condition occurred.

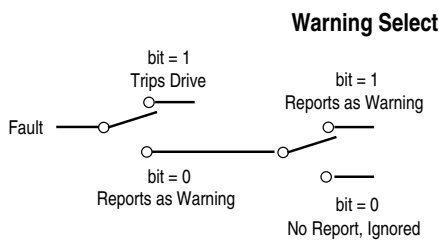
For bits 0, 1, 4, 5, and 15:

- The red VP light turns on.
- The motor coasts to a stop.

For bits 3 and 6 through 13:

- The red VP light turns on.
- The motor stops according to how bits 1 – 3 in *Logic Options* (parameter 17) are set.

If this bit is set:	Then this stop type is used:
1	Coast
2	Current limit
3	Ramp



For each condition that you want the drive to display a warning fault on, you need to:

1. Set the corresponding bit in *Warning Select 2*.
2. Make sure the corresponding bit in *Fault Select 2* is set to 0.

When the drive trips on a condition that you set to display a warning:

- The green VP light flashes.
- The drive continues to run.

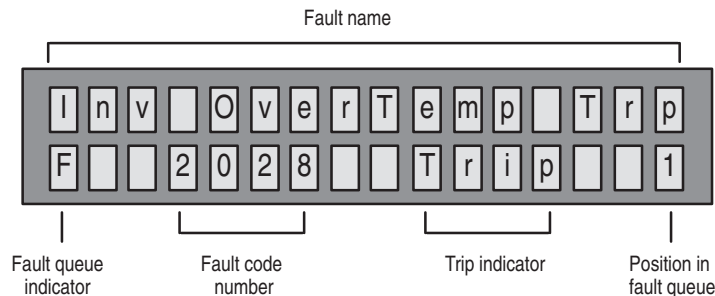
If a particular bit is not set in either *Fault Select 2* or *Warning Select 2*, the drive ignores the condition when it occurs. For example, if there is a loss of feedback and bit 0 in both *Fault Select 2* and *Warning Select 2* is 0, the drive ignores the loss of feedback.

### Viewing the Fault and Warning Queues on the HIM

You can use the HIM to view the fault and warning queues. To view the fault queue, you need to:

1. Press the *Escape* key until you reach the *Choose Mode* level.
2. Use the *Increment* or *Decrement* key to scroll through the *Choose Mode* options until *Control Status* is displayed.
3. Press the *Enter* key.
4. Use the *Increment* or *Decrement* key to scroll through the *Control Status* options until *Fault Queue* is displayed.
5. Press the *Enter* key.
6. Press the *Enter* key when *View Queue* is displayed.

The fault queue can contain up to 32 faults. The 1336 IMPACT drive reports the faults using the following format:





The trip indicator is only present if this fault caused the drive to trip. The last number (1) indicates the position of this fault within the fault queue.

A marker is placed in the queue when the first fault occurs after a power up sequence. This power up marker is as shown.



The 1336 IMPACT drive keeps track of the time that has elapsed since power up. The drive uses this information as a time stamp so that you can tell when a fault occurred in relation to when the drive was powered up. To view the time stamp, you need to use *Test Data 2* (parameter 94) and *Test Select 2* (parameter 95). You need to enter one value into *Test Select 2* to view the time in hours since power up and another value to view the minutes and seconds. These values are listed in the *Test Select 2* description in Chapter 11, *Parameters*.

As an example, if you want to know when the fault in position 12 occurred in relation to when the drive was powered up, you would need to do the following:

1. Enter a value of 11112 in *Test Select 2* (parameter 95).
2. Look at the value of *Test Data 2* (parameter 94). This value represents the number of hours after power up that the fault in position 12 occurred.
3. Enter a value of 11212 in *Test Select 2*.
4. Look at the value of *Test Data 2* to see the number of minutes and seconds after power up that the fault in position 12 occurred.

To clear the fault queue, select *Clear Queue* from the *Fault Queue* options.

To view the warning queue, select *Warning Queue* from the *Control Status* options. The remaining steps are the same as for the fault queue.

## What Are the Fault Descriptions?

When a fault occurs, the fault is displayed until you initiate a *Drive Reset* or a *Clear Faults* command. A *Drive Reset* clears all faults, while a *Clear Faults* command only clears soft and warning faults. You can perform a *Drive Reset* and *Clear Faults* either through bits in *Logic Input Sts* (parameter 14) or with a terminal.

The fault codes are defined as shown in Table 12.A.

**Table 12.A**  
**Fault Descriptions**

Fault Code and Text	LED Information	Fault Type	Description	Suggested Action
01027 <i>Autotune Diag</i>	VP, Flashing red	Soft	The drive encountered a problem while running the auto-tune tests. When this condition occurs, the drive coasts to a stop regardless of the selected stop type.	Check <i>Autotune Errors</i> (parameter 176). For additional information about <i>Autotune Errors</i> , refer to Chapter 13, <i>Understanding the Auto-tuning Procedure</i> .
01051 <i>MtrOvrlD Pnd</i>	VP, Flashing red	Soft	A motor overload is pending. The drive has reached 95% of the level required for a motor overload trip (see fault 01052).	Check for possible motor overheating. If the motor temperature is excessive, reduce the accel/decel times (parameters 42 – 45) or reduce the load. If the motor temperature is acceptable, increase the value of <i>Motor Overload %</i> (parameter 26). If you do not want this condition to be reported as a fault, change bit 3 in <i>Fault Select 2</i> (parameter 22) to 0.
01052 <i>MtrOvrlD Trp</i>	VP, Flashing red	Soft	Motor overload tripped. The drive has reached the level of accumulated motor current over time as set by <i>Motor Overload %</i> (parameter 26).	Check for possible motor overheating. <ul style="list-style-type: none"> <li>If the motor temperature is excessive, reduce the accel/decel times (parameters 42 – 45) or reduce the load.</li> <li>If the motor temperature is acceptable, increase the value of <i>Motor Overload %</i> (parameter 26).</li> </ul> If you do not want this condition to be reported as a fault, change bit 4 in <i>Fault Select 2</i> (parameter 22) to 0.
01053 <i>Mtr Stall</i>	VP, Flashing red	Soft	The drive is in a limit condition for a period of time in excess of the value specified in <i>Motor Stall Time</i> (parameter 25) with the motor at zero speed.	Check <i>Torque Limit Sts</i> (parameter 87) to see which limit has occurred. Increase the appropriate limit parameter or reduce the load. If you do not want this condition to be reported as a fault, change bit 5 in <i>Fault Select 2</i> (parameter 22) to 0.
01083 <i>MtrOvrlD Pend</i>	VP, Flashing green	Warning	Motor overload pending. The drive has reached 95% of the level required for a motor overload trip (see fault 01084).	Check for possible motor overheating. If the motor temperature is excessive, reduce the accel/decel times (parameters 42 – 45) or reduce the load. If the motor temperature is acceptable, increase the value of <i>Motor Overload %</i> (parameter 26). If you do not want this condition to be reported as a warning, change bit 3 in <i>Warning Select 2</i> (parameter 23) to 0.
01084 <i>MtrOvrlD Trp</i>	VP, Flashing green	Warning	Motor overload tripped. The drive has reached the level of accumulated motor current over time as set by <i>Motor Overload %</i> (parameter 26).	Check for possible motor overheating. If the motor temperature is excessive, reduce the accel/decel times (parameters 42 – 45) or reduce the load. If the motor temperature is acceptable, increase the value of <i>Motor Overload %</i> (parameter 26). If you do not want this condition to be reported as a warning, change bit 4 in <i>Warning Select 2</i> (parameter 23) to 0.
01085 <i>Mtr Stall</i>	VP, Flashing green	Warning	The drive is in a limit condition for a period of time in excess of the value specified in <i>Motor Stall Time</i> (parameter 25) with the motor at zero speed.	Check <i>Torque Limit Sts</i> (parameter 87) to see which limit has occurred. Increase the appropriate limit parameter or reduce the load. If you do not want this condition to be reported as a warning, change bit 5 in <i>Warning Select 2</i> (parameter 23) to 0.

Fault Code and Text	LED Information	Fault Type	Description	Suggested Action
02028 <i>Inv Overtemp Trp</i>	VP, Flashing red	Soft	Inverter overtemperature trip. There is excessive temperature at the heatsink. When this condition occurs, the drive coasts to a stop regardless of the selected stop type.	Check the cabinet filters, drive fans, and heatsinks. Check the thermal sensor and sensor wiring (connector). Reduce the load or duty cycle if possible. Lower the value of <i>PWM Frequency</i> (parameter 10). Check the roof fan direction of rotation (H frame only). Rotation should be counter-clockwise when viewed from the top.
02049 <i>Inv Overtemp Pnd</i>	VP, Flashing red	Soft	An inverter overtemperature is pending. The inverter heatsink temperature is approaching the trip level.	Check the cabinet filters, drive fans, and heatsinks. Check the thermal sensor and sensor wiring (connector). Reduce the load or duty cycle if possible. Lower the value of <i>PWM Frequency</i> (parameter 10). Check the roof fan direction of rotation (H frame only). Rotation should be counter-clockwise when viewed from the top. If you do not want this condition to be reported as a fault, change bit 1 in <i>Fault Select 2</i> (parameter 22) to 0.
02061 <i>InvOvld Pend</i>	VP, Flashing red	Soft	An inverter (IT) overload is pending. The inverter current has been in excess of 105% of <i>Inverter Amps</i> (parameter 11) too long. Continued operation at this load level will cause an overload.	Reduce the load or duty cycle if possible. If you do not want this condition to be reported as a fault, change bit 13 in <i>Fault Select 2</i> (parameter 22) to 0. Refer to the Understanding the IT Inverter Protection section in Appendix B for more information.
02063 <i>Inv Overload</i>	VP, Flashing red	Soft	Inverter (IT) overload. The inverter current has been in excess of 105% of <i>Inverter Amps</i> (parameter 11) too long.	Reduce the load or duty cycle if possible. If you do not want this condition to be reported as a fault, change bit 15 in <i>Fault Select 2</i> (parameter 22) to 0.
02081 <i>Inv Overtemp Pnd</i>	VP, Flashing green	Warning	An inverter overtemperature is pending. The inverter heatsink temperature is approaching trip level.	Check the cabinet filters, drive fans, and heatsinks. Check the thermal sensor and sensor wiring (connector). Reduce the load or duty cycle if possible. Lower the value of <i>PWM Frequency</i> (parameter 10). Check the roof fan direction of rotation (H frame only). It should be counter-clockwise when viewed from the top. If you do not want this condition to be reported as a warning, change bit 1 in <i>Warning Select 2</i> (parameter 23) to 0.
02093 <i>InvOvld Pend</i>	VP, Flashing green	Warning	An inverter (IT) overload is pending. The inverter current has been in excess of 105% of <i>Inverter Amps</i> (parameter 11) too long. Continued operation at this load level will cause an overload.	Reduce the load or duty cycle if possible. If you do not want this condition to be reported as a warning, change bit 13 in <i>Warning Select 2</i> (parameter 23) to 0.
02095 <i>Inv Overload</i>	VP, Flashing green	Warning	Inverter (IT) overload. The inverter current has been in excess of 105% of <i>Inverter Amps</i> (parameter 11) too long.	Reduce the load or duty cycle if possible. If you do not want this condition to be reported as a warning, set bit 15 in <i>Warning Select 2</i> (parameter 23) to 0.
03008 <i>HW Malfunction</i>	VP, Red 1 blink	Hard	A hardware malfunction was detected on power up or reset. When this condition occurs, the drive coasts to a stop regardless of the selected stop type.	Recycle the power. If the fault does not clear, replace the main control board.
03009 <i>HW Malfunction</i>	VP, Red 2 blink	Hard	A hardware malfunction was detected on power up or reset. When this condition occurs, the drive coasts to a stop regardless of the selected stop type.	Recycle the power. If the fault does not clear, replace the main control board.

Fault Code and Text	LED Information	Fault Type	Description	Suggested Action
03010 <i>HW Malfunction</i>	VP, Red 3 blink	Hard	A hardware malfunction was detected on power up or reset. When this condition occurs, the drive coasts to a stop regardless of the selected stop type.	Recycle the power. If the fault does not clear, replace the main control board.
03011 <i>HW Malfunction</i>	VP, Red 4 blink	Hard	A hardware malfunction was detected on power up or reset. When this condition occurs, the drive coasts to a stop regardless of the selected stop type.	Recycle the power. If the fault does not clear, replace the main control board.
03012 <i>HW Malfunction</i>	VP, Red 5 blink	Hard	A hardware malfunction was detected on power up or reset. When this condition occurs, the drive coasts to a stop regardless of the selected stop type.	Recycle the power. If the fault does not clear, replace the main control board.
03014 <i>EE Checksum</i>	VP, Flashing red	Soft	The parameter database is corrupt.	Initialize parameters or: <ul style="list-style-type: none"> <li>• Perform a Recall Values operation.</li> <li>• Perform a Save Values operation.</li> <li>• Verify the parameters.</li> <li>• Reset the drive.</li> </ul> If the fault still occurs, replace the board.
03015 <i>HW Malfunction</i>	VP, Flashing red	Soft	A hardware malfunction has occurred.	Recycle the power. If the fault does not clear, replace the main control board (B frames through H frames) or the drive (A frames).
03022 <i>Diff Drv Type</i>	VP, Flashing red	Soft	The main control board has been initialized on a different size drive.	Issue a <i>Reset Defaults</i> command to set the drive parameters back to the default values.
03023 <i>SW Malfunction</i>	VP, Solid red	Hard	A software malfunction has occurred.	Recycle the power. If the fault does not clear, replace the main control board. If the fault still occurs, replace the gate driver board.
03024 <i>SW Malfunction</i>	VP, Solid red	Hard	A software malfunction has occurred. When this condition occurs, the drive coasts to a stop regardless of the selected stop type.	Recycle the power. If the fault does not clear, replace the main control board.
03025 <i>Absolute Overspd</i>	VP, Flashing red	Soft	The motor speed has exceeded the speed limit plus <i>Absolute Overspd</i> (parameter 24) settings. When this condition occurs, the drive coasts to a stop regardless of the selected stop type.	If operating in torque mode, check if the load is allowing excessive motor speed. Check if the setting of <i>Absolute Overspd</i> (parameter 24) or the speed limits (parameters 40 and 41) are too low.
03026 <i>Analog Spplly Tol</i>	VP, Flashing red	Soft	The analog supply tolerance voltage is outside of the 13V to 18V range. When this condition occurs, the drive coasts to a stop regardless of the selected stop type.	Possible faulty analog 15V power supply. The power supply or the main control board may require replacement.
03029 <i>SW Malfunction</i>	VP, Solid red	Hard	A software malfunction has occurred.	Recycle the power. If the fault does not clear, replace the main control board.
03030 <i>SW Malfunction</i>	VP, Solid red	Hard	A software malfunction has occurred. When this condition occurs, the drive coasts to a stop regardless of the selected stop type.	Recycle the power. If the fault does not clear, replace the main control board.
03031 <i>SW Malfunction</i>	VP, Solid red	Hard	A software malfunction has occurred.	Recycle the power. If the fault does not clear, replace the main control board.

Fault Code and Text	LED Information	Fault Type	Description	Suggested Action
03040 <i>mA Input</i>	VP, Flashing red	Soft	A loss of 4 – 20mA input has occurred.	Check your wiring and connections. If the fault does not clear, replace the main control board. If you do not want this condition to be reported as a fault, change bit 8 in <i>Fault Select 1</i> (parameter 20) to 0.
03057 <i>Param Limit</i>	VP, Flashing red	Soft	A parameter limit has occurred.	Examine the parameter limit testpoints to determine the exact cause. Refer to the <i>Understanding the Parameter Limit Faults</i> section later in this chapter. If you do not want this condition to be reported as a fault, change bit 9 in <i>Fault Select 2</i> (parameter 22) to 0.
03058 <i>Math Limit</i>	VP, Flashing red	Soft	A math limit has occurred.	Examine the math limit testpoints to determine the exact cause. Refer to the <i>Understanding the Math Limit Faults</i> section later in this chapter. If you do not want this condition to be reported as a fault, change bit 10 in <i>Fault Select 2</i> (parameter 22) to 0.
03072 <i>mA Input</i>	VP, Flashing green	Warning	A loss of 4 – 20mA input has occurred.	Check your wiring and connections. If you do not want this condition to be reported as a warning, change bit 8 in <i>Warning Select 1</i> (parameter 21) to 0.
03089 <i>Param Limit</i>	VP, Flashing green	Warning	A parameter limit has occurred.	Examine the parameter limit testpoints to determine the exact cause. Refer to the <i>Understanding the Parameter Limit Faults</i> section later in this chapter. If you do not want this condition to be reported as a warning, change bit 9 in <i>Warning Select 2</i> (parameter 23) to 0.
03090 <i>Math Limit</i>	VP, Flashing green	Warning	A math limit has occurred.	Examine the math limit testpoints to determine the exact cause. Refer to the <i>Understanding the Math Limit Faults</i> section later in this chapter. If you do not want this condition to be reported as a warning, change bit 10 in <i>Warning Select 2</i> (parameter 23) to 0.
05048 <i>Spd Fdbk Loss</i>	VP, Flashing red	Soft	A loss of feedback occurred.	Check the encoder wiring. Verify that the encoder signals are free of noise. If you do not want this condition to be reported as a fault, change bit 0 in <i>Fault Select 2</i> (parameter 22) to 0.
05054 <i>External Flt In</i>	VP, Flashing red	Soft	The external fault input from the L Option board is open.	Check the external circuit for cause of an open input signal. If you do not want this condition to be reported as a fault, change bit 6 in <i>Fault Select 2</i> (parameter 22) to 0.
05080 <i>Spd Fdbk Loss</i>	VP, Flashing green	Warning	A loss of feedback occurred.	Check the encoder wiring. Verify that the encoder signals are free of noise. If you do not want this condition to be reported as a warning, change bit 0 in <i>Warning Select 2</i> (parameter 23) to 0.
05086 <i>External Flt In</i>	VP, Flashing green	Warning	The external fault input from the L Option board is open.	Check the external circuit for cause of an open input signal. If you do not want this condition to be reported as a warning, change bit 6 in <i>Warning Select 2</i> (parameter 23) to 0.
06041 <i>SP 1 Timeout</i>	VP, Flashing red	Soft	The SCANport adapter at port 1 has been disconnected and the logic mask bit for port 1 is set (1).	If the adapter was not intentionally disconnected: <ul style="list-style-type: none"> <li>• Check the wiring to the SCANport adapters.</li> <li>• Replace wiring, SCANport expander, SCANport adapters, and main control board.</li> <li>• Complete drive, if required.</li> </ul> If you do not want this condition to be reported as a fault, change bit 9 in <i>Fault Select 1</i> (parameter 20) to 0.

Fault Code and Text	LED Information	Fault Type	Description	Suggested Action
06042 <i>SP 2 Timeout</i>	VP, Flashing red	Soft	The SCANport adapter at port 2 has been disconnected and the logic mask bit for port 2 is set (1).	<p>If the adapter was not intentionally disconnected:</p> <ul style="list-style-type: none"> <li>• Check the wiring to the SCANport adapters.</li> <li>• Replace wiring, SCANport expander, SCANport adapters, and main control board.</li> <li>• Complete drive, if required.</li> </ul> <p>If you do not want this condition to be reported as a fault, change bit 10 in <i>Fault Select 1</i> (parameter 20) to 0.</p>
06043 <i>SP 3 Timeout</i>	VP, Flashing red	Soft	The SCANport adapter at port 3 has been disconnected and the logic mask bit for port 3 is set (1).	<p>If the adapter was not intentionally disconnected:</p> <ul style="list-style-type: none"> <li>• Check the wiring to the SCANport adapters.</li> <li>• Replace wiring, SCANport expander, SCANport adapters, and main control board.</li> <li>• Complete drive, if required.</li> </ul> <p>If you do not want this condition to be reported as a fault, change bit 11 in <i>Fault Select 1</i> (parameter 20) to 0.</p>
06044 <i>SP 4 Timeout</i>	VP, Flashing red	Soft	The SCANport adapter at port 4 has been disconnected and the logic mask bit for port 4 is set (1).	<p>If the adapter was not intentionally disconnected:</p> <ul style="list-style-type: none"> <li>• Check the wiring to the SCANport adapters.</li> <li>• Replace wiring, SCANport expander, SCANport adapters, and main control board.</li> <li>• Complete drive, if required.</li> </ul> <p>If you do not want this condition to be reported as a fault, change bit 12 in <i>Fault Select 1</i> (parameter 20) to 0.</p>
06045 <i>SP 5 Timeout</i>	VP, Flashing red	Soft	The SCANport adapter at port 5 has been disconnected and the logic mask bit for port 5 is set (1).	<p>If the adapter was not intentionally disconnected:</p> <ul style="list-style-type: none"> <li>• Check the wiring to the SCANport adapters.</li> <li>• Replace wiring, SCANport expander, SCANport adapters, and main control board.</li> <li>• Complete drive, if required.</li> </ul> <p>If you do not want this condition to be reported as a fault, change bit 13 in <i>Fault Select 1</i> (parameter 20) to 0.</p>
06046 <i>SP 6 Timeout</i>	VP, Flashing red	Soft	The SCANport adapter at port 6 has been disconnected and the logic mask bit for port 6 is set (1).	<p>If the adapter was not intentionally disconnected:</p> <ul style="list-style-type: none"> <li>• Check the wiring to the SCANport adapters.</li> <li>• Replace wiring, SCANport expander, SCANport adapters, and main control board.</li> <li>• Complete drive, if required.</li> </ul> <p>If you do not want this condition to be reported as a fault, change bit 14 in <i>Fault Select 1</i> (parameter 20) to 0.</p>
06047 <i>SP Error</i>	VP, Flashing red	Soft	SCANport communications have been interrupted.	<p>If the adapter was not intentionally disconnected:</p> <ul style="list-style-type: none"> <li>• Check the amount of noise on the system.</li> <li>• Check the wiring to the SCANport adapters.</li> <li>• Replace wiring, SCANport expander, SCANport adapters, and main control board.</li> <li>• Complete drive, if required.</li> </ul> <p>If you do not want this condition to be reported as a fault, change bit 15 in <i>Fault Select 1</i> (parameter 20) to 0.</p>
06073 <i>SP 1 Timeout</i>	VP, Flashing green	Warning	The SCANport adapter at port 1 has been disconnected and the logic mask bit for port 1 is set (1).	<p>If the adapter was not intentionally disconnected:</p> <ul style="list-style-type: none"> <li>• Check the wiring to the SCANport adapters.</li> <li>• Replace wiring, SCANport expander, SCANport adapters, and main control board.</li> <li>• Complete drive, if required.</li> </ul> <p>If you do not want this condition to be reported as a warning, change bit 9 in <i>Warning Select 1</i> (parameter 21) to 0.</p>

Fault Code and Text	LED Information	Fault Type	Description	Suggested Action
06074 <i>SP 2 Timeout</i>	VP, Flashing green	Warning	The SCANport adapter at port 2 has been disconnected and the logic mask bit for port 2 is set (1).	If the adapter was not intentionally disconnected: <ul style="list-style-type: none"> <li>• Check the wiring to the SCANport adapters.</li> <li>• Replace wiring, SCANport expander, SCANport adapters, and main control board.</li> <li>• Complete drive, if required.</li> </ul> If you do not want this condition to be reported as a warning, change bit 10 in <i>Warning Select 1</i> (parameter 21) to 0.
06075 <i>SP 3 Timeout</i>	VP, Flashing green	Warning	The SCANport adapter at port 3 has been disconnected and the logic mask bit for port 3 is set (1).	If the adapter was not intentionally disconnected: <ul style="list-style-type: none"> <li>• Check the wiring to the SCANport adapters.</li> <li>• Replace wiring, SCANport expander, SCANport adapters, and main control board.</li> <li>• Complete drive, if required.</li> </ul> If you do not want this condition to be reported as a warning, change bit 11 in <i>Warning Select 1</i> (parameter 21) to 0.
06076 <i>SP 4 Timeout</i>	VP, Flashing green	Warning	The SCANport adapter at port 4 has been disconnected and the logic mask bit for port 4 is set (1).	If the adapter was not intentionally disconnected: <ul style="list-style-type: none"> <li>• Check the wiring to the SCANport adapters.</li> <li>• Replace wiring, SCANport expander, SCANport adapters, and main control board.</li> <li>• Complete drive, if required.</li> </ul> If you do not want this condition to be reported as a warning, change bit 12 in <i>Warning Select 1</i> (parameter 21) to 0.
06077 <i>SP 5 Timeout</i>	VP, Flashing green	Warning	The SCANport adapter at port 5 has been disconnected and the logic mask bit for port 5 is set (1).	If the adapter was not intentionally disconnected: <ul style="list-style-type: none"> <li>• Check the wiring to the SCANport adapters.</li> <li>• Replace wiring, SCANport expander, SCANport adapters, and main control board.</li> <li>• Complete drive, if required.</li> </ul> If you do not want this condition to be reported as a warning, change bit 13 in <i>Warning Select 1</i> (parameter 21) to 0.
06078 <i>SP 6 Timeout</i>	VP, Flashing green	Warning	The SCANport adapter at port 6 has been disconnected and the logic mask bit for port 6 is set (1).	If the adapter was not intentionally disconnected: <ul style="list-style-type: none"> <li>• Check the wiring to the SCANport adapters.</li> <li>• Replace wiring, SCANport expander, SCANport adapters, and main control board.</li> <li>• Complete drive, if required.</li> </ul> If you do not want this condition to be reported as a warning, change bit 14 in <i>Warning Select 1</i> (parameter 21) to 0.
06079 <i>SP Error</i>	VP, Flashing green	Warning	SCANport communications have been interrupted.	If the adapter was not intentionally disconnected: <ul style="list-style-type: none"> <li>• Check the amount of noise on the system.</li> <li>• Check the wiring to the SCANport adapters.</li> <li>• Replace wiring, SCANport expander, SCANport adapters, and main control board.</li> <li>• Complete drive, if required.</li> </ul> If you do not want this condition to be reported as a warning, change bit 15 in <i>Warning Select 1</i> (parameter 21) to 0.

Fault Code and Text	LED Information	Fault Type	Description	Suggested Action
12016 <i>Overvoltage</i>	CP, Solid red	Hard	The DC bus voltage has exceeded the maximum value. When this condition occurs, the drive coasts to a stop regardless of the selected stop type.	Monitor the AC line for high line voltage or transient conditions. Increase the deceleration time or install the dynamic brake option because motor regeneration can also cause bus overvoltages. Refer to the description of <i>Bus Options</i> (parameter 13) for additional information about bus overvoltages. If you are using flux braking, refer to Chapter 9, <i>Applications</i> , for information about flux braking.
12017 <i>Desaturation</i>	CP, Solid red	Hard	There was too much current in the system. When this condition occurs, the drive coasts to a stop regardless of the selected stop type.	Run the power structure diagnostics. Check for a shorted motor or motor wiring. Replace the drive.
12018 <i>Ground Fault</i>	CP, Solid red	Hard	A current path to earth ground in excess of drive rated current has been detected at one or more of the drive output terminals. When this condition occurs, the drive coasts to a stop regardless of the selected stop type.	Run the power structure diagnostics. Check the motor and external wiring to the drive output terminals for a grounded condition. Replace the drive.
12019 <i>Overcurrent</i>	CP, Solid red	Hard	There was too much current in the system. When this condition occurs, the drive coasts to a stop regardless of the selected stop type.	Run the power structure diagnostics. Check for shorted motor or motor wiring. Replace drive.
12020	CP, Solid Red	Hard	VP and CP have lost communication	Cycle Power to Drive Reset Defaults Replace Main Control Board
12032 <i>RidethruTime</i>	CP, Flashing red	Soft	There was a bus voltage drop of 150V and power did not return within 2 seconds.	Check the incoming power and fuses. If you do not want this condition to be reported as a fault, change bit 0 in <i>Fault Select 1</i> (parameter 20) to 0.
12033 <i>Prechg Time</i>	CP, Flashing red	Soft	The precharge function could not complete within 30 seconds.	Refer to the <i>Understanding Precharge and Ridethrough Faults</i> section for more information. If you do not want this condition to be reported as a fault, change bit 1 in <i>Fault Select 1</i> (parameter 20) to 0.
12034 <i>Bus Drop</i>	CP, Flashing red	Soft	The bus voltage dropped 150V below the bus tracker voltage.	Monitor the incoming AC line for low voltage or line power interruption. Refer to the <i>Understanding Precharge and Ridethrough Faults</i> section for more information. If you do not want this condition to be reported as a fault, change bit 2 in <i>Fault Select 1</i> (parameter 20) to 0.
12035 <i>Bus Undervolt</i>	CP, Flashing red	Soft	The DC bus voltage fell below the minimum value (388V DC at 460V AC input).	Monitor the incoming AC line for low voltage or line power interruption. Refer to the <i>Understanding Precharge and Ridethrough Faults</i> section for more information. If you do not want this condition to be reported as a fault, change bit 3 in <i>Fault Select 1</i> (parameter 20) to 0 or decrease the bus undervoltage setpoint.
12036 <i>Bus Cycle&gt;5</i>	CP, Flashing red	Soft	At least 5 ridethrough cycles have occurred within a 20 second period. This indicates a converter problem or a problem with the incoming power.	Monitor the incoming AC line for low voltage or line power interruption. Refer to the <i>Understanding Precharge and Ridethrough Faults</i> section for more information. If you do not want this condition to be reported as a fault, change bit 4 in <i>Fault Select 1</i> (parameter 20) to 0.



Fault Code and Text	LED Information	Fault Type	Description	Suggested Action
12037 <i>Open Circuit</i>	CP, Flashing red	Soft	The fast flux up current is less than 50% of commanded.	Make sure the motor is properly connected. Refer to the <i>Understanding Precharge and Ridethrough Faults</i> section for more information. If you do not want this condition to be reported as a fault, change bit 5 in <i>Fault Select 1</i> (parameter 20) to 0.
12064 <i>RidethruTime</i>	CP, Solid green	Warning	There was a drop of 150V and power did not return within 2 seconds.	Check the incoming power and fuses. Refer to the <i>Understanding Precharge and Ridethrough Faults</i> section for more information. If you do not want this condition to be reported as a warning, change bit 0 in <i>Warning Select 1</i> (parameter 21) to 0.
12065 <i>Prechg Time</i>	CP, Solid green	Warning	The precharge function could not complete within 30 seconds.	Refer to the <i>Understanding Precharge and Ridethrough Faults</i> section for more information. If you do not want this condition to be reported as a warning, change bit 1 in <i>Warning Select 1</i> (parameter 21) to 0.
12066 <i>Bus Drop</i>	CP, Solid green	Warning	The bus voltage dropped 150V below the bus tracker voltage.	Monitor the incoming AC line for low voltage or line power interruption. Refer to the <i>Understanding Precharge and Ridethrough Faults</i> section for more information. If you do not want this condition to be reported as a warning, change bit 2 in <i>Warning Select 1</i> (parameter 21) to 0.
12067 <i>Bus Undervit</i>	CP, Solid green	Warning	The DC bus voltage fell below the minimum value (388V DC at 460V AC input).	Monitor the incoming AC line for low voltage or line power interruption. Refer to the <i>Understanding Precharge and Ridethrough Faults</i> section for more information. If you do not want this condition to be reported as a warning, change bit 3 in <i>Warning Select 1</i> (parameter 21) to 0.
12068 <i>Bus Cycle&gt;5</i>	CP, Solid green	Warning	At least 5 ridethrough cycles have occurred within a 20 second period. This indicates a converter problem or a problem with the incoming power.	Monitor the incoming AC line for low voltage or line power interruption. Refer to the <i>Understanding Precharge and Ridethrough Faults</i> section for more information. If you do not want this condition to be reported as a warning, change bit 4 in <i>Warning Select 1</i> (parameter 21) to 0.
12069 <i>Open Circuit</i>	CP, Solid green	Warning	The fast flux up current is less than 50% of commanded.	Make sure the motor is properly connected. Refer to the <i>Understanding Precharge and Ridethrough Faults</i> section for more information. If you do not want this condition to be reported as a warning, change bit 5 in <i>Warning Select 1</i> (parameter 21) to 0.
13000 <i>HW Malfunction</i>	CP, Solid red	Hard	A hardware malfunction occurred.	Recycle the power. If the fault does not clear, replace the board.
13001 <i>HW Malfunction</i>	CP, Solid red	Hard	A hardware malfunction occurred.	Recycle the power. If the fault does not clear, replace the board.
13002 <i>HW Malfunction</i>	CP, Solid red	Hard	A hardware malfunction occurred.	Recycle the power. If the fault does not clear, replace the board.
13003 <i>HW Malfunction</i>	CP, Solid red	Hard	A hardware malfunction occurred.	Recycle the power. If the fault does not clear, replace the board.
13004 <i>HW Malfunction</i>	CP, Solid red	Hard	A hardware malfunction occurred.	Recycle the power. If the fault does not clear, replace the board.

## Understanding Precharge and Ridethrough Faults

*file:* Application  
*group:* Bus Control

*file:* Fault Setup  
*group:* Fault Limits

To understand the precharge and ridethrough faults, you need a basic understanding of how these functions work, as well as the options that you can use to alter the way precharge and ridethrough operate in the 1336 IMPACT drive.

### Understanding Precharge

The precharge of the drive has different circuits depending on drive size. For the precharge operation for large horsepower (40 hp and larger) standalone drives, the precharge starts the SCR phase advance and completes precharge when the bus is stable. For all other drive types, precharge is completed after a stable bus voltage is achieved and the precharge device (SCR or relay) by-passes the precharge resistor. For common bus operation, set bit 12 in *Bus/Brake Opts* (parameter 13). The drive current and voltage ratings stored in EEPROM determine the standalone operation.

With the default configuration, the following conditions are needed to complete precharge:

- a stable bus voltage for a minimum of 300 milliseconds
- a bus voltage greater than the value set in *Line Undervlts* (parameter 27)

- a valid control status from the precharge board, if present

You can modify the default configuration for common bus drives by using the external fault (input) and the precharge exit option:

- You can use the external fault input with a cabinet disconnect switch to force precharge when the disconnect is opened and the drive is disabled. This may reduce current stress when the disconnect is closed again.
- You can use the exit precharge option to let the precharge complete after the precharge timeout period (30 seconds) when the bus voltage is not stable. All other conditions must be met. This is often used in the case of common or shared bus configurations where other drive(s) may be causing bus voltage variations. Only use this option where needed otherwise excessive inrush current could open or weaken the line fuses.

Before you can enable the inverter, all drive types must complete a first time precharge. This is required even if you have set the disable precharge function by setting bit 14 of *Bus/Brake Opts* (parameter 13).

A filtered, or slow, average of the bus voltage is developed as a reference, or bus voltage tracker, to determine if a line drop out has occurred. If a 150 volt (or greater) drop in present bus voltage compared to the filtered bus voltage occurs, the drive can start a ridethrough. The ridethrough function:

- disables the drive
- restarts a precharge
- waits for the bus to return to within 75 volts of the bus voltage tracker's voltage value before starting again.

You can use bits 0 – 4 of *Bus/Brake Opts* to control the slew rate of the bus voltage tracker. Refer to the section on the bus voltage tracker later in this chapter for additional information.

### Understanding Ridethrough

Ridethrough provides current inrush protection and extended logic operating time if the power lines drop out while the drive is running. The drive is immediately disabled when it senses that the incoming power lines dropped out (bus capacitor voltage drop). The energy stored in the bus capacitors keeps the logic supplies running for an extended time. If the power lines return before the logic power supplies lose power, you can configure the drive to resume operation without system intervention (default). The ridethrough timeout is set for two seconds. This means that the drive is configured to fault (default setting) and not auto-restart if the dropout lasts more than two seconds.



**ATTENTION:** You must determine safe auto-restart and fault configurations at the system and user level. Incorrect selection(s) may result in safety concerns and/or drive damage.

*file:* Fault Setup  
*group:* Fault Config

*Fault Select 1* (parameter 20) and *Warning Select 1* (parameter 21) let you specify how you want the drive to report specific precharge and ridethrough information.

Ridethrough also protects the drive from excessive inrush current when the power returns by entering a precharge mode when ridethrough is initiated. After precharge has finished, the drive can complete ridethrough and resume normal drive operation. The drive is enabled again after the bus rises to within 75 volts of the bus voltage tracker value.



**ATTENTION:** If you are using an external logic power supply, the drive may be able to stay in an indefinite ridethrough state. If the power returns to the drive (much later), the drive automatically restarts. You must therefore handle the control of enable, faults, time-outs, drive configuration, and safety issues at the system level.

Use the following parameters to configure the precharge and ridethrough functions:

- *Fault Select 1* (parameter 20)
- *Warning Select 1* (parameter 21)
- *Bus/Brake Opts* (parameter 13)
- *Line Undervolts* (parameter 27)

In addition, *Test Select 1* (parameter 93) and *Test Data 1* (parameter 92) contain software testpoints that provide additional precharge information.

*file:* Fault Setup

*group:* Fault Config

## Configuring the Faults and Warnings for Precharge

You can use *Fault Select 1* and *Warning Select 1* to enable fault/warning conditions when the appropriate bit is set (1). If a bit is clear (0) in *Fault Select 1*, you can choose to have the condition reported as a warning by setting the bit in *Warning Select 1*. The following are the bits that pertain to precharge:

This bit:	With this text:	When set, generates a fault when:
0	<b>RidethruTime</b>	The ridethrough time exceeds 2 seconds.
1	<b>Prechrg Time</b>	The precharge time exceeds 30 seconds.
2	<b>Bus Drop</b>	The bus voltage drops 150 volts below the bus tracker voltage. This is the level where the drive would normally enter ridethrough.
3	<b>Bus Undervlt</b>	The bus voltage drops below the level set in <i>Line Undervolts</i> (parameter 27). This is the level where the drive would enter ridethrough if it occurs before a 150 volt drop in bus voltage.
4	<b>Bus Cycles&gt;5</b>	At least 5 ridethrough cycles have occurred within a 20 second period. This indicates a converter problem or a problem with incoming power. Consider checking the incoming power for a phase loss.

## Using Bus/Brake Opts to Change Precharge/Ridethrough Options

*file:* Application

*group:* Bus/Reg/Control

You can use *Bus/Brake Opts* (parameter 13) to change how precharge and ridethrough work. *Bus/Brake Opts* is a bit encoded word that disables the following functions when the appropriate bit is set (1):

This bit:	Has this definition:
0	Sets the bus voltage tracker slew rate to 10 volts/second.
1	Sets the bus voltage tracker slew rate to 5 volts/second.
2	Sets the bus voltage tracker slew rate to 0.5 volts/second.
3	Sets the bus voltage tracker slew rate to 0.05 volts/second.
4	Sets the bus voltage tracker slew rate to 0.005 volts/second.
5	Reserved. Leave zero.
6	Enables flux braking. This is covered in more detail in Chapter 9, <i>Applications</i> .
7	Enables the DC hold feature. This is covered in more detail in Chapter 9, <i>Applications</i> .
8	Enables fast flux up. This is covered in more detail later in this chapter.
9	Enables DC braking. This is covered in more detail in Chapter 9, <i>Applications</i> .
10	Indicates that a chopper brake or other regenerative device is present.
11	Forces an exit from precharge after the precharge timeout.
12	Identifies the drive as a common bus converter.
13	Disables faults or warnings while the drive is disabled. This allows power up and down the bus for a common bus system without faulting even if the faults or warnings are enabled. For example, faults or warnings only occur if the drive is running. This may be desirable when external power supplies are used.

This bit:	Has this definition:
14	Disables the precharge function after initial power up. Any bus drop or undervoltage will not result in precharge. This may destroy the drive if power returns to the system. This should be used where you control the input impedance or with a front end converter with automatic current limiting.
15	Disables the ridethrough and precharge functions. If the power lines drop out, the drive attempts to continue operation as long as any power is available. This may destroy the drive if power returns to the system. This should be used only where you control the system's incoming power and provide external logic power.

*file:* Fault Setup  
*group:* Fault Limits

### Using Line Undervolts

You can use *Line Undervolts* (parameter 27) to set the level of bus voltage that must be present to complete precharge and a level where ridethrough can be initiated. If configured as a fault/warning, *Line Undervolts* sets the bus voltage level that faults/warns the drive. The bus voltage level that is used is determined as follows:

$Line\ Undervolts * Inverter\ Volts (parameter\ 12) * \sqrt{2} = \text{bus voltage level for ridethroughs, faults, or warnings}$

### Using Test Select 1 and Test Data 1 to View Software Testpoints

Additional information concerning precharges and ridethroughs is available through *Test Select 1* (parameter 93) and *Test Data 1* (parameter 92).

### Viewing the Calculated Undervoltage Value of Bus Voltage

To view the value of the calculated undervoltage:

1. Enter a value of 100 into *Test Select 1*.
2. Monitor *Test Data 1*.

You can use this to check the actual bus voltage that causes an undervoltage condition.

### Checking the Status of the Precharge

To view the precharge status, enter a value of 12 into *Test Select 1*, and then monitor *Test Data 1* for the precharge status. The precharge status is bit encoded as follows:

This bit:	When set, indicates that:
0	The precharge function has been completed and the precharge device should be on. The drive can be enabled only after this bit is set.
1	The drive is in ridethrough. Precharge must be completed and the bus must return to within 75 volts of the bus voltage tracker before normal drive operation can resume.
2	A precharge-initiated condition is in ridethrough.
3	A precharge has been requested due to an external fault (input).
4	The converter is ready for precharge and the controller may start its precharge function. The external precharge board is ok, if present.
5	The measured bus voltage is not stable (there is a variation of greater than ±25 volts) and the precharge cannot finish.
6	The DC bus voltage is less than line undervolts.

This bit:	When set, indicates that:
7	The precharge function cannot complete because the measured bus voltage is less than 75 volts below the bus voltage tracker. This only applies to precharging after a ridethrough.
8	The precharge device has been commanded ON.
9	Not used.
10	An exit from precharge was requested.
11	Precharge was skipped due to an enable dropout.
12	An initial (first) precharge is executed.
13	A high horsepower drive type is being used.

*file:* Application  
*group:* Fast Flux Up

### Enabling Fast Flux Up

You can use fast flux up to achieve rated flux conditions and consequently high torque as fast as possible after an enable. Under default conditions (no fast flux up), the drive brings the motor to rated flux conditions in a time proportional to the rotor time constant of the motor. These times range from 50 milliseconds for small motors to several seconds for large motors. If a high load is attempting to be started, no acceleration occurs until that time has elapsed. Enabling fast flux up can decrease that time by a factor of 5 to 10.

You can enable the fast flux up function of the drive by setting bit 8 of *Bus/Brake Opts* (parameter 13). In this case:

1. An amount of motor current set by *Fast Flux Level* (parameter 78) is applied to the flux producing axis for a time estimated to produce rated flux in the motor. The value of *Fast Flux Level* is set to 200% by default. You can reduce this value if it causes an undesirable torque pulsation. The time required to reach rated flux increases when you reduce this value.
2. The flux current is reset to nominal.
3. The drive is allowed to start producing torque.
4. Use *Test Select 1* (parameter 93) to check the approximate fluxing time. Enter a value of 86 into *Test Select 1* to display the fluxing time in *Test Data 1* (parameter 92). The time delay is given in seconds x 0.000977. If the flux time is 0, no fast flux up occurs and the drive starts normally. If at least 50% of the commanded current is not measured, you can configure the drive to fault at this time using *Fault Select 1* (Open Circuit).

### Forcing the Drive to Complete a Precharge

In some cases, the precharge may not complete due to external bus disturbances. Setting bit 11 in *Bus/Brake Opts* forces the precharge to complete at the precharge interval (default 30 seconds). This may cause precharge damage and should only be used when large inrush currents cannot occur.

## Understanding the Bus Voltage Tracker

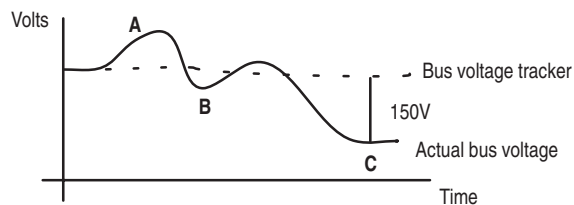
*Bus/Brake Opts* (parameter 13) also lets you select a rate, called a slew rate, for the bus voltage tracker. The bus voltage tracker slowly tracks changes in the actual bus voltage. If the actual bus voltage drops 150 volts or greater below the current value of the bus voltage tracker, the drive automatically disables modulation and enters precharge.

**Important:** You should only use the bus voltage tracker if you are having ridethrough problems. The bus voltage tracker adjusts the bus sensitivity to ridethrough for cases where there is an unstable bus.

By changing the rate used for the bus voltage tracker, you can make your system more or less sensitive to changes in the actual bus voltage. For example, if your drive currently enters precharge after the motor exits regeneration, you may need to change your slew rate.

Figure 12.2 shows an example of the filtered bus voltage reference.

**Figure 12.2**  
**Example Bus Voltage Line**



At point **A**, the motor was in regeneration, so the value of the bus voltage tracker slowly increased.

At point **B**, the motor was no longer in regeneration and the bus voltage had dipped below the nominal range. If the drive compared point B with point A, the drive would have seen a bus drop of 150V and entered precharge. However, because the drive compared point B with the bus voltage tracker, the bus drop was less than 150V and the drive continued operating.

At point **C**, the bus voltage had dropped 150V and the drive entered a precharge state.

*Bus/Brake Opts* provides the following options for changing the slew rate:

This bit:	With this text:	Sets the slew rate to:
0	<b>Slew Rate 1</b>	10V/second. This option is the most sensitive to changes in the actual bus voltage.
1	<b>Slew Rate 2</b>	5V/second.
2	<b>Slew Rate 3</b>	0.5V/second.
3	<b>Slew Rate 4</b>	0.05V/second.
4	<b>Slew Rate 5</b>	0.005V/second. This option is the least sensitive to changes in the actual bus voltage.

If all bits are clear (0), the slew rate is 0.05V/second. If more than one bit is set, the first bit that is set is used for the slew rate. For most applications, the default slew rate of 0.05V/second, which is 1 volt in 20 seconds, should be appropriate.

## Understanding the Parameter Limit Faults

If you receive a *Param Limit fault* (03057) or warning (03089), the drive has limited the value of one or more parameters. When you enter a parameter value from a programming device (such as a Human Interface Module (HIM)), the drive checks the value against the minimum and maximum parameter range. However, parameter values can also change as a result of a link to that parameter. When a parameter value is changed indirectly by a link, the drive performs additional limit checking on several critical parameters.

For example, if you create a link between *Pos Mtr Cur Lim* (parameter 72) and *An In 1 Value* (parameter 96), *An In 1 Value* could change the value of *Pos Mtr Cur Lim*. If the analog input level exceeds the range of *Pos Mtr Cur Lim*, the drive limits the data value that is stored as a current limit. When this happens, a parameter limit condition has occurred.

You can configure the drive to report a parameter limit condition as either a fault or a warning, or to ignore the condition.

To:	You need to:
Report the condition as a fault	Set bit 9 in <i>Fault Select 2</i> (parameter 22).
Report the condition as a warning	Clear bit 9 in <i>Fault Select 2</i> and set bit 9 in <i>Warning Select 2</i> (parameter 23).
Ignore the condition	Make sure that bit 9 is clear in both <i>Fault Select 2</i> and <i>Warning Select 2</i> .

The drive performs a parameter limit check regardless of how you configure it to report the condition.

### Using the Parameter Limit Testpoints

When a parameter limit fault or warning occurs, you need to look at two software testpoints, *Test Data 2* (parameter 94) and *Test Select 2* (parameter 95) to identify which parameter(s) is being limited.

If *Test Data 2* is non-zero, the value indicates which parameter limit condition has occurred. A bit position is assigned to each limit condition. Therefore, a value of 1 corresponds to bit 0, 2 for bit 1, 4 for bit 2, and so forth. Typically, only a single parameter limit condition will occur at a time. If multiple conditions do occur, you need to interpret the testpoint value as a combination of more than one bit, for example bits 0 and 1 = decimal value 1+2 = 3.

To view the testpoints:

1. Enter a value of 10503 into *Test Select 2* (parameter 95).
2. Look at the value of *Test Data 2* (parameter 94). If *Test Data 2* is zero, go on to step 3. If *Test Data 2* is non-zero, use the following table to determine which parameter is being limited.

If <i>Test Data 2</i> is:	Then, this parameter:	Has been limited to:
1 (bit 0)	<i>Rev Speed Limit</i> (parameter 40)	The minimum/maximum range
2 (bit 1)	<i>Fwd Speed Limit</i> (parameter 41)	The minimum/maximum range

*file:* Fault Setup  
*group:* Testpoints



<b>If Test Data 2 is:</b>	<b>Then, this parameter:</b>	<b>Has been limited to:</b>
4 (bit 2)	<i>Min Flux Level</i> (parameter 71)	The minimum/maximum range
8 (bit 3)	<i>Pos Mtr Cur Lim</i> (parameter 72)	The minimum/maximum range
16 (bit 4)	<i>Neg Mtr Cur Lim</i> (parameter 73)	The minimum/maximum range
32 (bit 5)	<i>Current Rate Lim</i> (parameter 77)	Positive numbers
128 (bit 7)	<i>Max Rev Spd Trim</i> (parameter 61)	Zero or negative numbers
256 (bit 8)	<i>Max Fwd Spd Trim</i> (parameter 62)	Zero or positive numbers

3. Enter a value of 10504 into *Test Select 2* (parameter 95).
4. Look at the value of *Test Data 2* (parameter 94). If *Test Data 2* is zero, no parameters in this group are being limited. If *Test Data 2* is non-zero, use the following table to determine which parameter is being limited.

<b>If Test Data 2 is:</b>	<b>Then this parameter:</b>	<b>Has been limited to:</b>
4 (bit 2)	<i>Ki Speed Loop</i> (parameter 158)	The minimum/maximum range
8 (bit 3)	<i>Kp Speed Loop</i> (parameter 159)	The minimum/maximum range
16 (bit 4)	<i>Kf Speed Loop</i> (parameter 160)	The minimum/maximum range
32 (bit 5)	<i>Fdbk Device Type</i> (parameter 64)	The minimum/maximum range
64 (bit 6)	<i>Fdbk Filter BW</i> (parameter 67)	The minimum/maximum range
128 (bit 7)	<i>Inverter Amps</i> (parameter 11)	The minimum/maximum range
512 (bit 9)	<i>Error Filtr BW</i> (parameter 162)	The minimum/maximum range
1024 (bit 10)	<i>Nameplate RPM</i> (parameter 3)	The minimum/maximum range
2048 (bit 11)	<i>Encoder PPR</i> (parameter 8)	The minimum/maximum range
4096 (bit 12)	<i>Nameplate Amps</i> (parameter 4)	The minimum/maximum range. <i>Nameplate Amps</i> must be less than or equal to twice <i>Inverter Amps</i> (parameter 11).
-32768 (bit 15)	<i>Droop Percent</i> (parameter 46)	The minimum/maximum range

The parameter limit testpoints are cleared when you clear the faults. Once you know which parameter(s) is being limited, you can determine why the parameter was limited. In many cases, a link from the limited parameter to another parameter will explain how the limit value was reached. For example, a link to an analog input value.

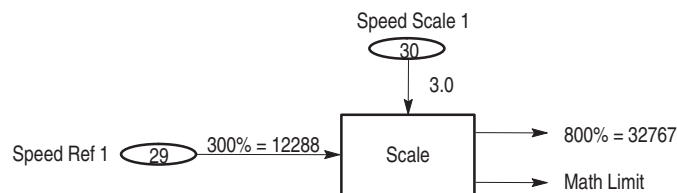
The fact that a parameter limit condition occurred does not by itself create a problem for the drive because the drive limits the parameter to a valid number. The ability to configure a fault or warning is provided to let you determine when a potential application problem exists — the requested action cannot be achieved because an attempt was made to set a parameter outside its limits. If this situation is understood and acceptable, then you can simply set up the drive for a *Param Limit* warning (clear bit 9 in *Fault Select 2* (parameter 22) and set bit 9 in *Warning Select 2* (parameter 23) or to ignore the condition entirely (clear both bits). By default, this condition is ignored (both bits clear).

## Understanding the Math Limit Faults

If you receive a *Math Limit* fault (03058) or warning (03090), the drive has limited a mathematical operation. This typically occurs when a calculation (add, subtract, multiply, or divide) results in a value that exceeds the range of the drive's number system. Most numeric quantities are restricted to  $\pm 800\%$ , which is expressed internally as a 16-bit number in the range of  $\pm 32767$ .

For example, suppose *Speed Ref 1* (parameter 29) is 300% of base motor speed (12,288 decimal) and *Speed Scale 1* (parameter 30) is +3.0. When the drive is run in speed mode with *Speed Ref 1* selected, the speed reference calculation will encounter a math limit condition. In this example, when *Speed Ref 1* is scaled by *Speed Scale 1*, the result becomes too large to express as a valid number and must be internally limited. 300% of base motor speed multiplied by a 3.0 scale factor would result in a speed reference value of 900% base motor speed ( $12288 \times 3 = 36864$ ). The 1336 IMPACT drive handles this condition by limiting the scaled speed reference value to eight times base motor speed (32767). A math limit condition would indicate that a positive overflow has occurred. If the calculation produced a negative result, then a negative overflow would be indicated.

**Figure 12.3**  
**Example of a Math Limit on Scaled Speed Ref 1**  
**(Positive Overflow)**



You can configure the drive to report a math limit condition as either a fault or a warning, or to ignore the condition.

To:	You need to:
Report the condition as a fault	Set bit 10 in <i>Fault Select 2</i> (parameter 22).
Report the condition as a warning	Clear bit 10 in <i>Fault Select 2</i> and set bit 10 in <i>Warning Select 2</i> (parameter 23).
Ignore the condition	Make sure that bit 10 is clear in both <i>Fault Select 2</i> and <i>Warning Select 2</i> .

### Understanding Math Limit Testpoints

To determine which math limit has occurred, you need to examine several testpoints by entering the appropriate number in *Test Select 2* (parameter 95) and looking at the value of *Test Data 2* (parameter 94). If *Test Data 2* is non-zero, a math limit has been reached. The math limit testpoints are cleared when faults are cleared.

If *Test Data 2* is non-zero, the value indicates which math limit condition has occurred. A bit position is assigned to each limit condition. Therefore, a value of 1 corresponds to bit 0, 2 for bit 1, 4 for bit 2, and so forth. Typically, only a single math limit condition will occur at a time. If multiple conditions do occur, you need to interpret the testpoint value as combinations of more than one bit. For example, bits 0 and 1 = decimal value 1+2 = 3.

To determine which math limit has occurred, you need to:

1. Enter a value of 10505 into Test Select 2 (parameter 95).
2. Look at the value of *Test Data 2* (parameter 94). If *Test Data 2* is zero, go on to step 3. If *Test Data 2* is non-zero, there is a problem in the speed reference area and the drive could not achieve the correct reference value. The drive used the largest possible reference instead. The following table provides more specific information.

If <i>Test Data 2</i> is:	Then:
1 (bit 0)	When <i>Speed Scale 1</i> (parameter 30) was applied to <i>Speed Ref 1</i> (parameter 29), a positive overflow occurred.
2 (bit 1)	When <i>Speed Scale 1</i> (parameter 30) was applied to <i>Speed Ref 1</i> (parameter 29), a negative overflow occurred.
4 (bit 2)	When <i>Speed Scale 7</i> (parameter 37) was applied to <i>Speed Ref 7</i> (parameter 36), a positive overflow occurred.
8 (bit 3)	When <i>Speed Scale 7</i> (parameter 37) was applied to <i>Speed Ref 7</i> (parameter 36), a negative overflow occurred.
256 (bit 8)	A positive overflow occurred during the trimmed speed reference (sum of Speed Ramp Output and Speed Trim).
512 (bit 9)	A negative overflow occurred during the trimmed speed reference (sum of Speed Ramp Output and Speed Trim).

To fix a problem in this area, reduce the maximum level of the speed reference or reduce the value of the speed scale parameter.

3. Enter a value of 10506 into *Test Select 2*.
4. Look at the value of *Test Data 2*. If *Test Data 2* is zero, go to step 5. If *Test Data 2* is non-zero, there is a problem in the speed feedback area. The problem may be with the encoder or wiring resulting in invalid motor speeds. The following table provides more specific information.

If <i>Test Data 2</i> is:	Then a divide overflow occurred during:
1 (bit 0)	The encoder speed calculation.
2 (bit 1)	The low speed calculation (part 1).
4 (bit 2)	The low speed calculation (part 2).

To fix a problem in this area, check for possible encoder faults. Also check for possible encoder problems or excessive noise on the encoder signals.

5. Enter a value of 10507 into *Test Select 2*.
6. Look at the value of *Test Data 2*. If *Test Data 2* is zero, go to step 7. If *Test Data 2* is non-zero, there is a problem in the speed regulator area. These conditions are unlikely to occur and indicate an unusual combination of gains, references, and feedback values. The drive attempts to regulate speed, however operation in a current limited condition is likely. The following table provides more specific information.

<b>If Test Data 2 is:</b>	<b>Then:</b>	<b>Occurred during:</b>
1 (bit 0)	A subtract overflow	The integral error calculation.
2 (bit 1)	A multiply overflow	The integral gain calculation.
4 (bit 2)	An overflow	The bumpless calculation.
8 (bit 3)	A subtract overflow	The droop offset.
256 (bit 8)	A subtract overflow	The speed error calculation.
512 (bit 9)	A subtract overflow	The Kf error calculation.

To fix a problem in this area, reduce the maximum level of speed reference. Check if *Total Inertia* (parameter 157) and *Spd Desired BW* (parameter 161) are appropriate for your system.

7. Enter a value of 10508 into *Test Select 2*.
8. Look at the value of *Test Data 2*. If *Test Data 2* is zero, go to step 9. If *Test Data 2* is non-zero, there is a problem in the torque reference area. These conditions indicate excessive levels of torque reference. The 1336 IMPACT drive uses a maximum internal torque reference of 800% and further limits this torque by the drive's torque and current limit settings.

<b>If Test Data 2 is:</b>	<b>Then:</b>
1024 (bit 10)	An overflow occurred when <i>Slave Torque %</i> (parameter 70) was applied to <i>Torque Ref 1</i> (parameter 69).
4096 (bit 12)	An add overflow occurred for <i>Torque Ref 1 + Torque Trim</i> .
8192 (bit 13)	An add overflow occurred for the torque sum mode.
16384 (bit 14)	A divide overflow occurred for the torque to current conversion (divide by flux).

To fix a problem in this area, determine if the torque reference levels are excessive and possibly reduce the maximum level of torque reference.

9. Enter a value of 10509 into *Test Select 2*.

10. Look at the value of *Test Data 2*. If the value of *Test Data 2* is zero, no problems occurred in this area. If the value of *Test Data 2* is non-zero, there is a problem in the process trim area. These conditions are generally due to using reference quantities or gains that are too large to represent in the drive's number system. The drive attempts to let the process trim function, but operation in a limited condition is likely.

If <i>Test Data 2</i> is:	Then:	Occurred during:
1 (bit 0)	A subtract overflow	The process trim error calculation.
2 (bit 1)	An overflow	The process trim bumpless calculation (unable to preset output upon rise of enable with existing gains).
4 (bit 2)	An add overflow	The process trim integral calculation.
8 (bit 3)	An add overflow	The process trim output calculation.

To fix a problem in this area, reduce the maximum level of *PTrim Reference* (parameter 49) or adjust *PTrim Ki* (parameter 54) and *PTrim Kp* (parameter 55). Adjust *PTrim Out Gain* (parameter 60). Refer to the Trim Control Overview section of Appendix B, *Control Block Diagrams*, for additional information about these parameters.

### Math Limit Faults — General Comments

The math limit fault is similar to the parameter limit fault. Both faults indicate that a request was made to do something that the drive cannot achieve. The 1336 IMPACT drive attempts to honor the request by using the largest possible data value that is consistent with the requested data. In many cases, the drive functions under this limited condition until the data is brought back within a controllable range.

When a math limit fault occurs, evaluate *Test Select 2* and *Test Data 2* to determine the specific cause. The suggested action depends on the cause. If drive operation is acceptable as it is, configure the drive to either indicate a *Math Limit* warning or to not report the condition. *Math Limit* warnings are reported when bit 10 in *Fault Select 2* (parameter 22) is clear and bit 10 in *Warning Select 2* (parameter 23) is set. The *Math Limit* condition is not reported when both bits are cleared.

## Start Up Troubleshooting Procedures

If you are having problems with the start up procedure, refer to this table for possible solutions before calling for help.

If:	Then:
You powered up your drive and cannot access the start up routine.	The start up procedure is not supported on a Series A Human Interface Module (HIM). To verify that you have a Series A HIM, check the series letter located on the back side of the HIM or check the HIM version when you first power up your drive.
You got a <i>Feedback Loss Fault</i> .	You have specified that an encoder is on the system but it has been disconnected.

If:	Then:
The motor does not turn during the phase rotation test.	Remove the load from the motor and try running the auto-tune tests again. Afterwards, you will need to attach the load again and run the inertia test manually. Refer to Chapter 13, <i>Understanding the Auto-tuning Procedure</i> , for additional information.
During the phase rotation test you were asked to swap the encoder leads. You changed the leads and ran start up again. You were asked to swap the leads again.	The drive is not getting any speed feedback information. You need to: <ul style="list-style-type: none"> <li>• Check the connection between the encoder and the motor.</li> <li>• Run the phase rotation test again and escape out to the status display at the first question. Check the motor speed. It should ramp to 3 Hz (90 rpm) for a 60 Hz 4 pole motor. If the motor speed is 0 rpm, you should: <ul style="list-style-type: none"> <li>– Check the encoder wiring.</li> <li>– Check the encoder itself.</li> </ul> </li> </ul>
The drive completes the auto-tune tests but you want a better response.	Adjust <i>Accel Time 1</i> (parameter 42) and <i>Decel Time 1</i> (parameter 44) before you change the values of any of the bandwidth, Ki, or Kp parameters.

## Miscellaneous Troubleshooting Procedures

If you are having problems with how your 1336 IMPACT drive is operating, refer to this table for possible solutions before calling for help.

If:	Then you should:
The drive does not respond to start or jog commands.	<ul style="list-style-type: none"> <li>• Make sure the power is applied.</li> <li>• Check if the port is enabled in <i>SP Enable Mask</i> (parameter 124).</li> <li>• Check if start is enabled in <i>Start/Jog Mask</i> (parameter 126).</li> <li>• Check if <i>Start/Stop Owner</i> (parameter 129) and <i>Jog1/Jog2 Owner</i> (parameter 130) are both 0. If not, open start and/or jog inputs and close stop inputs.</li> <li>• Check if the drive is faulted.</li> <li>• Check <i>Run Inhibit Sts</i> (parameter 16) for possible cause.</li> </ul>
You cannot clear faults.	<ul style="list-style-type: none"> <li>• Check if the port is enabled in <i>SP Enable Mask</i> (parameter 124).</li> <li>• Check if clear faults is enabled in <i>Clr Flt/Res Mask</i> (parameter 127).</li> <li>• Check if clear fault owners in <i>Ramp/CIFlt Owner</i> (parameter 131) is set. If set, check stop owners in <i>Start/Stop Owner</i> (parameter 129) and remove stop conditions.</li> <li>• The fault is a hard fault which requires a power cycle or drive reset.</li> </ul>
The motor does not turn or run at the correct speed.	<ul style="list-style-type: none"> <li>• Check which speed reference the drive is following in <i>Drive/Inv Status</i> (parameter 21) bits 13 – 15.</li> <li>• Check if <i>Spd/Trq Mode Sel</i> (parameter 68) is set correctly.</li> <li>• Check if <i>Spd Desired BW</i> (parameter 161) is non-zero.</li> <li>• Set the drive defaults and run start up again to tune the drive.</li> <li>• If drive is in encoderless w/deadband mode, check to see if reference is less than 1Hz.</li> </ul>

If:	Then you should:
The HIM pot does not control motor speed.	<ul style="list-style-type: none"> <li>• Check if <i>SP An In1 Select</i> (parameter 133) or <i>SP An In2 Select</i> (parameter 136) is set to the HIM port number.</li> <li>• Check if <i>SP An In1 Scale</i> (parameter 135) or <i>SP An In2 Scale</i> (parameter 138) is 0.125.</li> <li>• Check if a <i>Speed Ref 1 – 7</i> (parameters 29 through 36) is linked to <i>SP An In1 Value</i> (parameter 134) or <i>SP An In2 Value</i> (parameter 137).</li> <li>• Check which speed reference the drive is following in <i>Drive/Inv Status</i> (parameter 21) bits 13 – 15. The speed reference should be set to the speed reference that <i>SP An In1 Value</i> (parameter 134) or <i>SP An In2 Value</i> (parameter 137) is linked to.</li> </ul>
The drive will not change direction.	<ul style="list-style-type: none"> <li>• Check if the port is enabled in <i>SP Enable Mask</i> (parameter 124).</li> <li>• Check if Direction is enabled in <i>Dir/Ref Mask</i> (parameter 125).</li> <li>• Check if Direction owner in <i>Dir/Ref Owner</i> (parameter 128) has any bit set. If so, remove the command direction.</li> <li>• Check to make sure that bit 11 in <i>Logic Options</i> (parameter 17) is clear (0).</li> </ul>
You cannot change the speed reference.	<ul style="list-style-type: none"> <li>• Check if the port is enabled in <i>SP Enable Mask</i> (parameter 124).</li> <li>• Check if Reference is enabled in <i>Dir/Ref Mask</i> (parameter 125).</li> <li>• Check if Reference owner in <i>Dir/Ref Owner</i> (parameter 128) has any bit set. If so, remove the command reference. If bit 0 (for the L Option control) is set, you need to do one of the following to remove ownership: <ul style="list-style-type: none"> <li>• Clear bit 0 in <i>Dir/Ref Mask</i> (parameter 125).</li> <li>• If <i>L Option Mode</i> (parameter 116) is 2, 3, 8, 9, 23, 24, or 26, close the L Option inputs for speed references 1, 2, and 3.</li> </ul> </li> </ul>
The drive does not run correct torque.	<ul style="list-style-type: none"> <li>• Set the drive defaults and run start up again to tune the drive.</li> <li>• Check <i>Spd/Trq Mode Sel</i> (parameter 68) and <i>Slave Torque %</i> (parameter 70).</li> </ul>
The drive cannot control current and trips on an overcurrent fault.	<p>If you are using an encoder, check that you have entered the current PPR into <i>Encoder PPR</i> (parameter 8).</p>
The MOP does not work.	<ul style="list-style-type: none"> <li>• Check <i>L Option Mode</i> (parameter 116).</li> <li>• Make sure that <i>Mop Value</i> (parameter 119) is linked to a speed reference.</li> </ul>
The pulse input does not work.	<ul style="list-style-type: none"> <li>• Make sure that the pulse input jumper is set correctly.</li> <li>• Make sure that the input is differential and not single ended.</li> <li>• Check the values of <i>Pulse In PPR</i> (parameter 120), <i>Pulse In Scale</i> (parameter 121), and <i>Pulse In Offset</i> (parameter 122).</li> <li>• Check the link on <i>Pulse In Value</i> (parameter 123).</li> </ul>

## Encoderless Troubleshooting Problems

If you are having problems with encoderless mode, refer to this table for possible solutions before calling for help.

If:	Then you should:
The motor will not accelerate or does not start smoothly	<ul style="list-style-type: none"> <li>• Increase the bandwidth in <i>Spd Desired BW</i> (parameter 161). If the bandwidth is too low, the motor may not accelerate, although the current increases to current limit.</li> <li>• If the regen power limit is 0, increase it to at least -5%.</li> <li>• Increase the torque and current limits to the maximum.</li> <li>• Increase the value of <i>Kp Freq Reg</i> (parameter 178).</li> </ul>
The motor oscillates after it is up to speed	<ul style="list-style-type: none"> <li>• Decrease the bandwidth in <i>Spd Desired BW</i> (parameter 161) if the process will allow. If this does not help, depending on your application, you need to either increase or decrease the value of <i>Error Filter BW</i> (parameter 162).</li> </ul>
The inverter trips on absolute overspeed during starting	<ul style="list-style-type: none"> <li>• Increase the acceleration time.</li> <li>• If the overspeed occurs during a fast acceleration, increase the value of <i>Kp Freq Reg</i> (parameter 178) until the trip stops occurring.</li> <li>• Increase the bandwidth.</li> <li>• If the overspeed occurs during a reversal, increase the deceleration time (slower deceleration).</li> </ul>



## Understanding the Auto-tuning Procedure

### Chapter Objectives

The 1336 IMPACT drive runs the auto-tune routines as part of the Quick Motor Tune routine.

**Important:** You can skip this chapter if your drive passed the auto-tune tests performed during the Quick Motor Tune routine. You should only need to read this chapter if your drive faulted during any of the auto-tune tests.

This topic:	Starts on page:
A description of auto-tuning	13-1
Running the power structure and transistor diagnostics tests	13-2
Running the phase rotation test	13-5
Running the sequential torque tuning tests	13-6
Running the inertia test	13-9
Checking the auto-tune status	13-13

### What Is Auto-tuning?

Auto-tuning is a procedure that involves running a group of tests on the motor/drive combination. Some tests check the drive hardware and other tests configure drive parameters to maximize the performance of the attached motor.



**ATTENTION:** You must apply power to the drive and connect the motor for the auto-tune tests. Some of the voltages present are at incoming line potential. To avoid electrical shock hazard or damage to equipment, only qualified service personnel should perform the following procedures

**Important:** If you stop the drive once the resistance, inductance, flux, and inertia tests begin, the drive will fault.

*file:* Autotune  
*group:* Autotune Setup

To manually run the auto-tune test, you need to use *Autotune/Dgn Sel* (parameter 173). It has the following bit definitions:

To run this test:	You need to set this bit:	Must the load be coupled to the motor? <sup>1</sup>
Inverter transistor diagnostics	0	No
Motor phase rotation test	1	No
Inductance measure test	2	No
Rs measure test (resistance)	3	No
Flux current measure test	4	No
Inertia test	5	Yes

<sup>1</sup> Although the motor does not have to be coupled to the load during these tests, you can have it coupled to the load during any of the tests. The motor must be coupled to the drive for all of these tests.

Bits 6 through 15 are reserved; leave 0.

**Important:** You must run the motor phase rotation test, inductance test, resistance test, flux test, and inertia test in order.

To run a particular test:

1. Set the bit in *Autotune/Dgn Sel* that corresponds to the test you want to run.
2. Enable the drive.

When the test is complete, the bit is cleared (0). If a fault occurred, refer to the *Troubleshooting* section.

You can run the auto-tune tests individually.

## Running the Power Structure and Transistor Diagnostics Tests

*file:* Control  
*group:* Drive Logic Select

The power structure and transistor diagnostics routines let you determine if any problems exist in the power structure of the drive and determine the probable cause of these problems.

The diagnostic software determines hardware problems through a series of system tests. These tests are parameter dependent. The test results depend on drive size, motor size, system wiring, and other factors that affect system voltage and load impedance.

In most cases, the software can properly determine if faults exist; however, there may be some installations where some faults cannot be properly checked. In general, test results are listed as failed if a questionable case is found. You must review test results with respect to the whole drive system to properly interpret whether a real problem exists.

You can run the transistor diagnostics before a start by setting bit 8 of *Logic Options* (parameter 17). Transistor diagnostics require motor current, so a user-start transition is required to run the tests.

To run the transistor diagnostics independently:

1. In *Autotune/Dgn Sel* (parameter 173), set bit 0 to 1.
2. Enable the drive.

The green enable light (D1) turns on very briefly (approximately 300 ms) and then turns off. This runs only the transistor diagnostics and leaves the drive disabled after the diagnostics are complete.

*Autotune/Dgn Sel* is automatically cleared to zero after the diagnostics have run.

*file:* Autotune  
*group:* Autotune Setup

Because the test results depend on your particular system, you can disable tests that may give questionable or nuisance faults. Use *Trans Dgn Config* (parameter 172) to disable individual tests:

If you want to disable:	Then, set this bit:
Current feedback phase U offset tests	0
Current feedback phase W offset tests	1
Shorted power transistor tests	2
Ground fault tests	3
Open transistor, open motor, open current feedback, open gate drive, and open bus fuse tests	4
Power transistor U upper for all tests	6
Power transistor U lower for all tests	7
Power transistor V upper for all tests	8
Power transistor V lower for all tests	9
Power transistor W upper for all tests	10
Power transistor W lower for all tests	11

Bits 5 and 12 through 15 are reserved. You must leave these bits 0.



*Even though you set bits 6 through 11 to disable the individual tests, you will still get a fault with the other tests if there is an open in an individual section.*

To test specific modules within the power structure, you can disable any transistor or any combination of transistors. You must leave all transistors enabled under most conditions. Use sound judgement to verify that power transistor fault conditions do not exist before disabling tests.

*file:* Autotune  
*group:* Autotune Status

*Inverter Dgn1* (parameter 174) and *Inverter Dgn2* (parameter 175) contain the results of the transistor diagnostic tests.

**Important:** Serious component failures may occur if unverified power transistor fault conditions are ignored or tests are disabled before you proceed to run the drive under load.

*Inverter Dgn1* (parameter 174) is defined as follows:

When this bit is set (1):	Then:
0	A software fault occurred.
1	No motor is connected, or a bus fuse is open.
2	Phase U and W shorted.
3	Phase U and V shorted.
4	Phase V and W shorted.
5	There are shorted modules.
6	A ground fault occurred.
7	A fault occurred before the short module ran.
8	A hardware overvoltage fault occurred.
9	A hardware desat fault occurred.
10	A hardware ground fault occurred.
11	A hardware phase overcurrent fault occurred.
12	There are open power transistor(s).
13	There are current feedback faults.

Bits 14 and 15 are reserved.

*Inverter Dgn2* (parameter 175) is defined as follows:

When this bit is set (1):	Then:
0	Transistor U upper shorted.
1	Transistor U lower shorted.
2	Transistor V upper shorted.
3	Transistor V lower shorted.
4	Transistor W upper shorted.
5	Transistor W lower shorted.
6	The current feedback phase U offset is too large.
7	The current feedback phase W offset is too large.
8	Transistor U upper open.
9	Transistor U lower open.
10	Transistor V upper open.
11	Transistor V lower open.
12	Transistor W upper open.
13	Transistor W lower open.
14	Current feedback phase U open.
15	Current feedback phase W open.

If any hardware fault occurs during the open transistor testing, then the following occur:

- The hardware fault is saved.
- A phase-to-phase fault is set.

- All subsequent testing is stopped.
- Some untested devices may be set as open.

Typically, you should fix the hardware faults and run open tests again to determine if any opens exist.

### What Do Open Transistor Faults Indicate?

Open transistor faults could indicate an open anywhere in the control or power section that turns on a given transistor. You should check the power transistor gate drive signal from the control board through the cabling to the opto-isolators continuing through the gate drives and finally through the cabling to the power transistor. This includes the power wiring to the motor terminals and the motor. If the bus voltage is too low, opens could occur; bus voltage should be greater than 85% of nominal line.

### What Happens If Multiple Opens Occur?

If multiple opens occur, several additional faults may be indicated. For example, if transistor U upper and U lower are open, the test also indicates that current feedback U phase is open. Because current cannot run through phase U, the current feedback device cannot be checked and therefore is listed as a malfunction. The type of installation often determines which parts of the transistor diagnostics may or may not work. As a result, treat the software only as an aid for testing the power structure.

### What Do I Do If I Get a Software Fault?

If bit 0 of *Inverter Dgn 1* is set (1), an improper sequence of events has occurred. Either the software cannot distinguish what is occurring, or there is noise in the system. If a fault occurs repeatedly, the problem may be a fault that the software cannot directly identify (for example, a voltage breakdown in a snubber). If this is the case, you need to determine through external measurements if the problem is real or if there is a noise problem. In cases where a specific test continually results in nuisance faults, use *Trans Dgn Config* (parameter 172) to disable that test.

## Running the Phase Rotation Test

For proper drive operation, you need to have:

- A specific phase sequence of the motor leads (T1 T2 T3, T1 T3 T2 etc.)
- A specific sequence of encoder leads (pulse A leads B, etc.)

These sequences determine which direction the motor shaft rotates when torque is applied. If the sequence is not set up correctly, the motor may rotate in the wrong direction or no torque may be produced.

To run the phase rotation test:

1. Set bit 1 in *Autotune/Dgn Sel* (parameter 173).
2. Enable the drive.

<p><i>file:</i> Autotune <i>group:</i> Autotune Setup</p>
---

3. Check if the motor is running in what you define as the positive direction. If it is not, stop the drive, swap the T1 and T2 motor leads, and return to step 1.
4. For encoder-based systems, with the motor turning in the positive direction, check that *Motor Speed* (parameter 81) is positive. If the value is not positive, swap encoder leads TB3-32 and TB3-34, and go back to step 1.



*Motor Speed is 0 during this test if an encoder is not present.*

## Running the Sequential Torque Tuning Tests

Bits 2 through 5 of *Autotune/Dgn Sel* control the sequential torque control tuning tests.

If during any of the next tests bit 0 (negative or zero slip) of *Autotune Errors* (parameter 176) is set, then *Nameplate RPM* (parameter 3) is less than the motor synchronous speed determined from *Nameplate Hz* (parameter 6) and *Motor Poles* (parameter 7). For example, a 4 pole 60 Hz motor has a synchronous speed of 1800 rpm. Here, a motor nameplate rpm of 1750 rpm results in 50 rpm, or 1.67 Hz, of slip.

### Running the Inductance Test

A measurement of the motor inductance is required to determine the references for the regulators that control torque. This test measures the motor inductance and displays it in *Leak Inductance* (parameter 167).

When running this test, you should be aware of the following:

- The motor should not rotate during this test although rated voltages and currents are present and the possibility of rotation exists. For encoderless systems, you must visually verify that the motor does not rotate.
- This test is run at rated motor current and by-passes the normal current limit functions.

Before running the inductance test, make sure that you have entered the correct motor nameplate information.

To run the inductance test:

1. Set bit 2 in *Autotune/Dgn Sel* (parameter 173).
2. Enable the drive.

The drive enable light turns off when the test is complete. The inductance test runs for approximately 1 minute. When a reading is obtained in *Leak Inductance*, perform the resistance test.

Typical values for per unit inductance are in the range of 15% to 25% motor impedance. The value shown in *Leak Inductance* is a percent value. If you are using long wiring runs, the typical value for per unit inductance should increase by the ratio of wiring inductance to motor inductance.

<p><i>file:</i> Autotune</p> <p><i>group:</i> Autotune Results</p>
--

<p><i>file:</i> Autotune</p> <p><i>group:</i> Autotune Setup</p>
--

*file:* Autotune  
*group:* Autotune Status

The motor inductance measuring routine contains several special faults. If the drive trips during the inductance test, check bits 1 through 5 of *Autotune Errors* (parameter 176):

If this bit is set (1):	Then:
1	<p><b>Ind-&gt;0 Spd</b> The motor is not at zero speed. Generally, this bit is set in two cases:</p> <ul style="list-style-type: none"> <li>• If the motor rotates during this test, an improper result is likely. Make sure the motor (decoupled from load or process) is not rotating just before or during the test.</li> <li>• If the motor is not rotating during this test, then investigate electrical noise creating encoder transitions. Improper encoder grounding or a noisy encoder power supply could cause noise.</li> </ul> <p>This fault cannot be determined for encoderless applications. You must visually check for this condition on encoderless systems. If your motor does rotate during this test, consult the factory.</p>
2	<p><b>Ind-Sign Err</b> A sign error fault occurs when the average voltage is negative. If you receive a sign error, you need to:</p> <ol style="list-style-type: none"> <li>1. Run the test again.</li> <li>2. Consider replacing the circuit boards.</li> </ol>
3	<p><b>Ind-0 Cur</b> If this bit is set, you need to:</p> <ol style="list-style-type: none"> <li>1. Set the rated motor current in <i>Nameplate Amps</i> (parameter 4) to the correct value.</li> <li>2. Run the test again.</li> <li>3. Consider replacing the control board.</li> </ol>
4	<p><b>Ind-A/D Ovfl</b> The motor terminal voltage measuring circuit is not working properly. You need to:</p> <ol style="list-style-type: none"> <li>1. Determine if the motor is connected.</li> <li>2. Check cable connections between the gate drive and control boards.</li> <li>3. Consider replacing the circuit boards.</li> <li>4. Investigate any noise problems.</li> </ol>
5	<p><b>Ind-En Drop</b> The drive enable was lost during the inductance test. Consider running the test again and monitor the drive enable (bit 9 of <i>Drive/Inv Status</i> (parameter 15) and/or the Inv En LED on the main control board.</p>

*file:* Autotune  
*group:* Autotune Results

## Running the Resistance Test

The drive requires a motor resistance measurement to determine the references for the regulators that control torque. The motor resistance test measures the motor resistance and displays it in *Stator Resistnce* (parameter 166). The test runs for approximately 10 – 30 seconds.

When running this test, you should be aware of the following:

- The motor should not rotate during this test although rated voltages and currents are present and the possibility of rotation exists. For encoderless systems, you must visually verify that the motor does not rotate.
- This test is run at rated motor current and by-passes the normal current limit functions.

Before running the resistance test make sure that you have entered the correct motor nameplate information.

To run the motor resistance test:

1. Set bit 3 in *Autotune/Dgn Sel* (parameter 173).
2. Enable the drive.

The drive enable light turns off when the test is complete. When a reading is obtained in *Stator Resistnce*, perform the flux test.

*file:* Autotune  
*group:* Autotune Setup

Typical values for per unit motor resistance are in the range of 1% to 3% as displayed in *Stator Resistance*. The value in *Stator Resistance* increases as the length of wiring runs increase.

<i>file:</i> Autotune <i>group:</i> Autotune Status
--

Several faults have been included to identify some problems that can occur in the resistance measuring routine. If the drive trips during the resistance test, check bits 6 through 10 of *Autotune Errors* (parameter 176):

If this bit is set:	Then:
6	<p><b>Res- &gt;0 Spd</b>            The motor is not at zero speed. Generally, this bit is set in two cases:</p> <ul style="list-style-type: none"> <li>• If the motor rotates during this test, an improper result is likely. Make sure the motor (decoupled from load or process) is not rotating just before or during the test.</li> <li>• If the motor is not rotating during this test, then investigate electrical noise creating encoder transitions. Improper encoder grounding or a noisy encoder power supply could cause noise.</li> </ul> <p>This fault cannot be determined for encoderless applications. You must visually check for this condition on encoderless systems.            If your motor does rotate during this test, consult the factory.</p>
7	<p><b>Res-Sign Err</b>            A sign error fault occurs when the average voltage is negative. If you receive a sign error, run the test again because the value returned is not reliable.</p>
8	<p><b>Res-0 Cur</b>            If this bit is set, you need to:</p> <ol style="list-style-type: none"> <li>1. Set the rated motor current in <i>Nameplate Amps</i> (parameter 4) to the correct value.</li> <li>2. Run the test again.</li> <li>3. Consider replacing the control board.</li> </ol>
9	<p><b>Res-SW Err</b>            A software fault is generated when an improper sequence of events has occurred. Consider running the test again.</p>
10	<p><b>Res-En Drop</b>            The drive enable was lost during the resistance test. Consider running the test again and monitor the drive enable (bit 9 of <i>Drive/Inv Status</i> (parameter 15) and/or the Inv En LED on the main control board).</p>

## Running the Flux Current Test

Rated motor flux is required to produce rated torque at rated current. The motor flux test measures the amount of current required to produce rated motor flux and displays the amount in *Flux Current* (parameter 168). The motor accelerates to approximately two-thirds base speed and then coasts for several seconds. This cycle may repeat several times. The motor then decelerates to a low speed before disabling.

<i>file:</i> Autotune <i>group:</i> Autotune Setup
---

If the motor will not accelerate, increase *Autotune Torque* (parameter 164) until the motor accelerates. *Autotune Speed* (parameter 165) changes the speed to which the motor accelerates.

**Important:** You must run the transistor diagnostics, phase rotation, inductance, and resistance tests before running this test.

To run the motor flux test:

1. Set bit 4 in *Autotune/Dgn Sel* (parameter 173).
2. Enable the drive.

The drive enable light turns off when the test is complete.



*file:* Autotune  
*group:* Autotune Results

Typical values for rated motor flux range from 20% to 50% as displayed in *Flux Current* (parameter 168). Several faults have been added to identify some problems that can occur in the flux test. If the drive trips while the flux test is being performed, check bits 11 through 15 of *Autotune Errors* (parameter 176):

If this bit is set:	Then:
11	<b>Flx-Atune Lo</b> The auto-tune speed setpoint is set too low. The lowest value that should be used for the auto-tune speed setpoint is 30% of the minimum rated speed. You should increase the value of <i>Autotune Speed</i> (parameter 165).
12	<b>Flx-Flux &lt; 0</b> One or more of the parameters are incorrectly set, electrical noise is/was present, motor phasing could be incorrect, or other problems exist.
13	<b>Flx-Cur&gt;MCur</b> The flux current is greater than 100% motor nameplate current. This may be due to incorrect parameter settings, an undersized drive for the motor, or a motor problem.
14	<b>Flx-En Drop</b> The drive enable was lost during the flux test.
15	<b>Flx-Hi Load</b> Too much load is on the motor. Reduce the load to get a valid flux number. If you disconnect the load for this test, you must reconnect it before running the inertia test.



*If you have problems while running the flux test, you may need to verify that parameters are set properly. You should then run the stator resistance and leak inductance tests again and verify that the results are typical as described in these sections.*

The following parameters directly effect the flux test.

Parameter Name	Parameter Number	Value/Comments
Rev Speed Limit	40	Set this to the limit of the application. If set to 0, the motor may not accelerate.
Fwd Speed Limit	41	Set this to the limit of the application. If set to 0, the motor may not accelerate.
Pos Mtr Cur Lim	72	Set this to the limit of the application. If set too low, the motor may not accelerate.
Neg Mtr Cur Lim	73	Set this to the limit of the application. If set too low, the motor may not accelerate.
Regen Power Lim	76	If set too high, you may trip out on a Bus Overvolts. <sup>1</sup>
Autotune Torque	164	100% allows 1 per unit (p.u.) torque during acceleration.
Autotune Speed	165	±68% is the maximum for the flux test. This is limited internally by the software.

<sup>1</sup> The option to regenerate to stop following identification of flux producing current should function properly with or without a brake or regeneration unit.

*file:* Control  
*group:* Control Limits

*file:* Autotune  
*group:* Autotune Setup

## Running the Inertia Test

The inertia test measures the inertia of the motor and connected load (machine). The drive requires an accurate inertia value to set the bandwidth or responsiveness of the speed regulator. You can select operation at any bandwidth at or below the calculated maximum bandwidth.

To run the inertia test:

1. Set bit 5 in *Autotune Dgn Sel* (parameter 173).
2. Enable the drive.

The motor should accelerate up to the speed specified in *Autotune Speed* (parameter 165) at a rate limited by the torque specified in *Autotune Torque* (parameter 164). The motor stops and the drive updates *Total Inertia* (parameter 157). The Ki and Kp gains are adjusted based on the results of the inertia test, the setting of Kf gain, and the setting of *Spd Desired BW* (parameter 161), which is the desired bandwidth setting for the drive's speed regulator. Bandwidth is limited based on the results of the inertia tests.

### Tuning the Speed Regulator

Tuning the speed regulator refers to setting three regulator gains, Ki, Kp, and Kf, to get the desired drive response to changes in speed reference and load. The 1336 IMPACT drive uses a modified PI (proportional integral) controller for the speed regulator. You can adjust the setting of the regulator gains either automatically or manually.

The Kp (proportional) and Ki (integral) gain settings for the speed regulator affect the stability of the regulator and the response to changes in speed reference and load disturbances. You can adjust the Ki and Kp gains automatically by selecting a speed bandwidth. You can also set these gains manually. The automatic method is preferable, as it is easier and also sets the *Kf Speed Loop* (parameter 160), *Fdbk Filter Sel* (parameter 65), and *Error Filtr BW* (parameter 162) according to the *Fdbk Device Type* (parameter 64).

To use automatic tuning:

1. Run the inertia test to get the correct value for *Total Inertia* (parameter 157). If you cannot run the inertia test, perhaps because of mechanical limitations, you can manually enter the inertia value. *Total Inertia* is defined as the time, in seconds, the drive takes to accelerate the motor and load from zero to rated motor speed at rated motor torque. If measurements are made at less than rated conditions, extrapolate the results to rated conditions.
2. Following the inertia test, the drive adjusts the maximum range and present setting of speed bandwidth, *Spd Desired BW* (parameter 161). These adjustments are made based on the measured value of *Total Inertia*. High inertias imply low bandwidths, and low inertias imply high bandwidths.

The drive sets six parameters when it completes the inertia test. How these parameters are set depends on how *Fdbk Device Type* (parameter 64) is set.

*file:* Autotune

*group:* Autotune Results

If *Fdbk Device Type* is set for encoderless, the parameters are set as follows:

This parameter:	Is set to this value:
<i>Min Flux Level</i> (parameter 71)	25.0%
<i>Fdbk Filter Sel</i> (parameter 65)	1 (35/49 radians/second)
<i>Kf Speed Loop</i> (parameter 160)	0.7
<i>Error Filtr BW</i> (parameter 162)	500.0 radians/second

*Total Inertia* and *Spd Desired BW* are set as follows:

When <i>Total Inertia</i> (parameter 157) is:	Then <i>Spd Desired BW</i> (parameter 161) is set to:
$\text{inertia} \leq 0.3$ seconds	15 radians/second
$0.3 \text{ seconds} < \text{inertia} < 2$ seconds	10 radians/second
$2 \text{ seconds} \leq \text{inertia} < 5$ seconds	5 radians/second
$5 \text{ seconds} \leq \text{inertia} < 20$ seconds	1 radians/second
$\text{inertia} \geq 20$ seconds	0.5 radians/second

If *Fdbk Device Type* is set for an encoder, the parameters are set as follows:

This parameter:	Is set to this value:
<i>Min Flux Level</i> (parameter 71)	25.0%
<i>Fdbk Filter Sel</i> (parameter 65)	0 (none)
<i>Kf Speed Loop</i> (parameter 160)	1.0

*Total Inertia*, *Spd Desired BW*, and *Error Filtr BW* are set as follows:

When <i>Total Inertia</i> (parameter 157) is:	<i>Spd Desired BW</i> (parameter 161) is set to:	And <i>Error Filtr BW</i> (parameter 162) is set to:
$\text{inertia} \leq 0.3$ seconds	25 radians/second	125 radians/second
$0.3 \text{ seconds} < \text{inertia} < 2$ seconds	16 radians/second	80 radians/second
$2 \text{ seconds} \leq \text{inertia} < 5$ seconds	8 radians/second	40 radians/second
$5 \text{ seconds} \leq \text{inertia} < 20$ seconds	1.6 radians/second	25 radians/second
$\text{inertia} \geq 20$ seconds	0.8 radians/second	25 radians/second

In many cases, the automatic selection by the drive for the bandwidth setting provides acceptable performance and no further adjustments are required. However, if you want a faster response to speed reference and less speed disturbance to changes in load, increase the bandwidth. Conversely, if you want a slower response, decrease the bandwidth. Mid-range settings at half the maximum bandwidth value are a good place to start when adjusting the bandwidth. The drive sets the regulator  $K_p$  and  $K_i$  gains when the bandwidth adjustment is made.

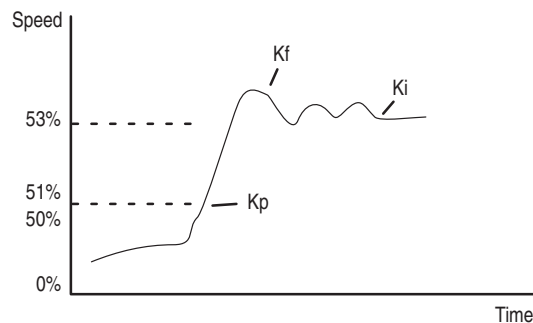
**Important:** If you set the speed regulator bandwidth too high, the motor and load could chatter. If set too low, response will be sluggish.

<i>file:</i> Control <i>group:</i> Speed Regulator
---

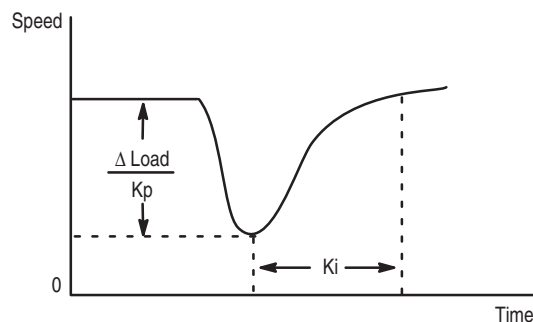
To use manual tuning:

1. Adjust *Kp Speed Loop* (parameter 159) to set how quickly the drive responds to changes in reference and load. Higher values of gain result in faster response to reference changes and less speed disturbance due to changes in load. Excessive values of *Kp* gain cause the motor and load to chatter as noise in the speed feedback signal becomes amplified. Large adjustments in the *Kp* gain require you to adjust the *Ki* gain to maintain stability.
2. Adjust *Ki Speed Loop* (parameter 158) to determine how quickly the drive recovers from speed and load changes. Increasing the *Ki* gain causes the drive to recover faster from a load disturbance. Adjusting *Ki* gain also removes any steady state (long term) instabilities. Excessive values of *Ki* gain cause the system to become oscillatory and unstable. For higher bandwidth systems (systems with bandwidths over 3 to 5 radians/second), *Ki* is larger than *Kp*. For low bandwidth systems, *Kp* is larger than *Ki*.
3. Verify affects of the *Kp* and *Ki* gain adjustments using a small step change in speed reference and/or load. Large changes (more than a few percent) cause the regulator to enter a limit condition and make checking the response difficult. You may need to repeatedly adjust the *Kp* and *Ki* gain to get the desired response, as these two gains interact with each other. Make only small adjustments at a time and then check the results.

**Figure 13.1**  
**Speed Regulator Small Reference Step Response (50% to 53% Step)**



**Figure 13.2**  
**Speed Regulator Step Load Disturbance Response**



**Important:** When you change either *Kp Speed Loop* or *Ki Speed Loop*, the 1336 IMPACT drive places the bandwidth value at zero. This turns off the automatic calculation of gains based on the setting of *Spd Desired BW* (parameter 161). The regulator then uses the custom Ki and Kp gain values that you entered. To return to automatic tuning of Ki and Kp, enter a non-zero bandwidth in *Spd Desired BW*. If possible, you should use automatic tuning.

### Adjusting the Kf Gain

*file:* Control  
*group:* Speed Regulator

In addition to the Ki and Kp regulator gains, a third gain term has been included. This gain is represented by Kf Speed Loop (parameter 160). The Kf gain affects speed overshoot in response to a step change in speed reference. You can adjust the Kf gain parameter at any time, independent from the proportional and integral gains. The drive chooses the default setting of Kf based on *Fdbk Device Type* (parameter 64) when the inertia test is performed. A Kf setting of 1.0 makes the control act like a conventional proportional-integral type regulator. You can set the Kf gain manually, based on overshoot:

When Kf is:	Then:
1.0	The speed loop acts like a normal PI loop with the overshoot equaling approximately 13%. This is the default setting for encoder-based systems.
0.7	The overshoot is typically less than 1%. 0.7 is the recommended operating point. This is the default setting for encoderless systems.
0.5	The response becomes underdamped with no overshoot. 0.5 is the lowest recommended value.

### Checking the Auto-tune Status

You can use *Autotune Status* (parameter 156) to view various conditions related to the auto-tune feature.

Autotune Status is defined as follows.

*file:* Autotune  
*group:* Autotune Status

If this bit is set:	Then:
0	<b>Executing</b> A test is currently executing.
1	<b>Complete</b> The test has finished executing.
2	<b>Fail</b> The test failed.
3	<b>Abort</b> A stop command was issued before the test completed.
4	<b>Flux active</b> The drive must not be running when auto-tune is requested.
5	<b>Not Ready</b> The ready input is not present.
6	<b>Not Zero Spd</b> Generally, this bit is set in two cases: <ul style="list-style-type: none"> <li>• If the motor rotates during this test, an improper result is likely. Make sure the motor (decoupled from load or process) is not rotating just before or during the test.</li> <li>• If the motor is not rotating during this test, then investigate electrical noise creating encoder transitions. Improper encoder grounding or a noisy encoder power supply could cause noise.</li> </ul> If your motor does rotate during this test, consult the factory.

If this bit is set:	Then:
7	<b>Running</b> The drive is currently running.
8 – 11	Reserved
12	<b>Timeout</b> The inertia test has run for one minute without measuring at least a 5% change in motor speed. Possible excessive load. Try running a higher level of <i>Autotune Torque</i> (parameter 164).
13	<b>No Trq Lim</b> The inertia test has measured a <i>Motor Speed</i> (parameter 81) in excess of half the <i>Autotune Speed</i> (parameter 165), but a <i>Torque Limit Sts</i> (parameter 87) has not been indicated. The drive enters a torque limit condition at the start of the inertia test. <ul style="list-style-type: none"><li>• Make sure the motor is stopped or at least rotating at less than half the auto-tune speed before beginning the inertia test.</li><li>• If the motor is not rotating at the start of the inertia test, investigate encoder and related wiring as a source for incorrect speed feedback.</li></ul>

## Specifications

### Chapter Objectives

Appendix A provides the specifications for the 1336 IMPACT drive.

This topic:	Starts on page:
Specifications	A-1
Input/output ratings	A-4
Cable and wiring requirements	A-5
Software block diagrams	A-6

### Specifications

The following table shows the specifications for the 1336 IMPACT drive:

This category:	Has these specifications:
<b>Environmental</b>	
Ambient operating temperature	IP00, Open: 0 to 50° C (32 to 122° F) IP20, NEMA Type 1 Enclosed: 0 to 40° C (32 to 104° F) IP65, NEMA Type 4 Enclosed: 0 to 40° C (32 to 104° F)
Storage temperature (all constructions)	-40 to 70° C (-40 to 158° F)
Atmosphere	<b>Important:</b> Drive <b>must not</b> be installed in an area where the ambient atmosphere contains volatile or corrosive gas, vapors or dust. If the drive is not going to be installed for a period of time, it must be stored in an area where it will not be exposed to a corrosive atmosphere.
Relative humidity	5 to 95% non-condensing
Altitude	1000m (3300 ft) without derating
Shock	15g peak for 11 ms duration (+1.0 ms)
Vibration	0.152 mm (0.006 inches) displacement. 1g peak

This category:	Has these specifications:
<b>Electrical</b>	
Input voltage rating* * See the derating curves for voltages above nominal.	200 – 240V AC, standalone, 3 phase, +10%, -15% nominal 380 – 480V AC, standalone, 3 phase, +10%, -15% nominal 500 – 600V AC, standalone, 3 phase, +10%, -15% nominal 513 – 621V DC, common bus, +10%, -15% nominal 776V DC, common bus, +10%, -15% nominal
Input power rating	2 – 134 KVA (230V) 2 – 437 KVA (380V) 2 – 555 KVA (460V) 2/3 – 578/695 KVA (500/600V)
Input frequency	50/60 Hz ( $\pm 3$ Hz)
Standard output voltage	Three voltage ranges are available. Each voltage range is line dependent and can power a motor between the following voltages: 200 – 240V AC (line dependent) 380 – 480V AC (line dependent) 500 – 600V AC (line dependent) If the voltage required for your application is not shown, contact Allen-Bradley for specific information. <b>Note:</b> Due to internal voltage drops in the power structure and voltage margins required for regulation, the drive is unable to produce full output voltage at base speed. If full horsepower is required at or above base speed, an increase in current is required to produce rated horsepower. This effect will occur in all drives, but is usually only significant in F, G, and, especially, H frame drives since the voltage drop is proportional to source inductance and load current.
Output power	2 – 116 KVA (230V) 2 – 190 KVA (380V) 2 – 208 KVA (415V) 2 – 537 KVA (460V) 2 – 671 KVA (575V) <b>Note:</b> For information on factors that could effect the power output of the drive, please refer to the enclosure and derating guidelines.
Output current	2.5 – 983A
Output horsepower (continuous)	7.5 – 800 hp
Overload capability	Continuous — 100% fundamental current 1 minute — 150%
Output frequency range	0 – 250 Hz
Output waveform	Sinusoidal (PWM)
Maximum short circuit current rating	200,000A rms symmetrical, 600 volts (when used with specified AC input line fuses as detailed in Chapters 3 and 4) Per Max Short Circuit Amps specific to each drive rating when using specified HMCP Breakers 200,000A when using specified HMCP Breakers with Current Limit Option
Ride through	2 seconds
Efficiency	97% typical



This category:	Has these specifications:		
<b>Performance</b>			
Speed regulation with an encoder	To 0.001% of rated motor speed over a 100:1 speed range To 0.02 % of rated motor speed over a 1000:1 speed range		
Speed regulation without an encoder	±0.5% of rated motor speed over a 120:1 speed range		
Torque regulation	To ±5% of rated motor torque, encoderless; ±2% with an encoder.		
Power loss ridethrough capability	2 seconds		
Flying start	Can start into a spinning motor		
Inverter overload capability	Constant torque: 150% of rated drive output for 1 minute.		
Motor overload capability	Adjustable to up to 400% of motor rating for 1 minute.		
Programmable accel/decel rates	From 0 to 6553 seconds		
Current limit	Programmable to 400% of rated motor current, not to exceed 150% of the drive output limit.		
<b>Control</b>			
Force Technologies: Field-oriented control, current-regulated, sine code PWM with programmable carrier frequency	<b>HP</b>	<b>Drive Rating</b>	<b>Carrier Frequency</b>
	1 – 3	4 kHz	1 – 12 kHz
	7.5 – 30	4 kHz	1 – 12 kHz
	40 – 60	4 kHz	1 – 12 kHz
	75 – 125	2 kHz	1 – 6 kHz
	150 – 250	2 kHz	1 – 6 kHz
	300 – 500	2 kHz	1 – 4 kHz
	600 – 650	1.5 kHz	1 – 4 kHz
	700 – 800	1 kHz	1 – 4 kHz
	Refer to the derating guidelines in Appendix D, <i>Derating Guidelines</i> .		
Output voltage range	0 to rated voltage		
Output frequency range	0 to 250 Hz		
Encoder	Incremental, dual channel; isolated with differential transmitter, 100 kHz maximum, quadrature: 90°±27° @ 25°C. Supply power: 12 volts, 500mA Input: 5 volts (2.5 volts minimum, 10mA minimum) or 12 volts (9.5 volts minimum, 10mA minimum)		
Accel/decel	Independently programmable acceleration and deceleration times. Program from 0 to 6553 seconds in 0.1 second increments.		
Current limit	±400% rated motor current up to inverter rating		
Inverse time overload capability	Class 20 protection with speed-sensitive response adjustable from 0 – 200% of rated output current in three speed ranges — 2:1, 4:1, and 10:1. UL certified — Meets NEC article 430.		
<b>Input/Output</b>			
0 to ±10V DC input	Input impedance of 20K Ohms		
4 – 20 mA input	Input impedance of 130 Ohms		
Pulse input	Differential, input 5 or 12V, maximum frequency of 100 kHz, 10 mA minimum		
0 to ±10V DC output	Output impedance of 100 Ohms, 10 mA maximum		
4 – 20 mA output	Output impedance of 273 Ohms; can drive up to 3 inputs		
DC power supply	±10V DC, 50 mA per voltage		
Fault contact	Resistive rating = 115 VAC/30VDC, 5.0A Inductive rating = 115 VAC/30VDC 2.0A		
Alarm contact	Resistive rating = 115VAC/30VDC, 5.0A Inductive rating = 115VAC/30VDC, 2.0A		

**Input/Output Ratings**

The input and output current ratings grouped by drive voltage rating are provided in the following tables:

200 – 240V					380 – 480V					500 - 600V				
Cat No.	Input kVA	Input Amps	Output kVA	Output Amps	Cat No.	Input kVA	Input Amps	Output kVA	Output Amps	Cat No.	Input kVA	Input Amps	Output kVA	Output Amps
AQF05	1.48	2.8	0.92	2.3	BRF05	1.54	1.4	0.96	1.2	CWF10	3.56	3	2.49	2.5
AQF07	1.93	3.5	1.20	3.0	BRF07	2.18	2.1	1.35	1.7	CWF20	5.98	4	4.18	4.2
AQF10	2.89	5.4	1.79	4.5	BRF10	2.96	2.8	1.83	2.3	CWF30	8.54	6	5.98	6.0
AQF15	3.86	7.3	2.39	6.0	BRF15	3.86	3.5	2.39	3.0	CWF50	11.24	8	7.87	7.9
AQF20	5.14	9.7	3.19	8.0	BRF20	5.14	4.8	3.19	4.0	CWF75	9 – 11	10	10	9.9
AQF30	7.71	14.3	4.78	12.0	BRF30	7.71	7.2	4.78	6.0	CWF100	11 – 13	12	12	12.0
AQF50	11.57	21.3	7.17	18.0	BRF50	11.57	12.0	7.17	10.4	C015	17 – 20	19	19	18.9
A007	10 – 12	28	11	27.2	BRF75	19.92	14	13.94	13.9	C020	21 – 26	25	24	23.6
A010	12 – 14	35	14	33.7	BRF100	28.46	25	19.92	24.0	C025	27 – 32	31	30	30.0
A015	17 – 20	49	19	48.2	B015	18 – 23	28	22	27.2	C030	31 – 37	36	35	34.6
A020	23 – 28	67	26	64.5	B020	23 – 29	35	27	33.7	C040	40 – 48	46	45	45.1
A025	25 – 30	73	31	78.2	B025	23 – 26	43	33	41.8	C050	48 – 57	55	57	57.2
A030	27 – 30	79	32	80.0	B030	32 – 41	49	38	48.2	C060	52 – 62	60	62	61.6
A040	43 – 51	123	48	120.3	BX040	40 – 50	62	47	58.7	C075	73 – 88	84	85	85.8
A050	53 – 64	154	60	149.2	B040	41 – 52	63	52	64.5	C100	94 – 112	108	109	109.1
A060	60 – 72	174	72	180.4	B050	48 – 60	75	61	78.2	C125	118 – 142	137	137	138.6
A075	82 – 99	238	96	240.0	BX060	62	75	61	78.2	C150	136 – 163	157	157	159.7
A100	100 – 120	289	116	291.4	B060	61 – 77	93	76	96.9	C200	217 – 261	251	251	252.6
A125	112 – 135	325	130	327.4	B075	78 – 99	119	96	120.3	C250	244 – 293	282	283	283.6
					B100	98 – 124	149	120	149.2	C300	256 – 307	296	297	298.0
					B125	117 – 148	178	143	180.4	CX300	256 – 307	295	297	298.0
					BX150	148	178	143	180.4	C350	304 – 364	351	352	353.6
					B150	157 – 198	238	191	240.0	CP350	301 – 361	347	349	350.0
					B200	191 – 241	290	233	291.4	CPR350	301 – 361	347	349	350.0
					B250	212 – 268	322	259	327.4	C400	349 – 419	403	405	406.4
					B/BP300	265 – 335	403	324	406.4	CP400	343 – 412	397	398	400.0
					BPR300	265 – 334	402	324	406.4	CPR400	343 – 412	397	398	400.0
					B/BP350	300 – 379	455	366	459.2	C450	394 – 473	455	457	459.2
					BPR350	300 – 379	455	366	459.2	C500	434 – 520	501	503	505.1
					B400	330 – 416	501	402	505.1	C600	514 – 617	594	597	599.2
					BP400	313-396	476	383	481.0	C650	578 – 694	668	671	673.4
					BPR400	313 – 396	476	383	481.0	C700C	616 – 739	756	767	770
					B450	372 – 470	565	454	570.2	C800C	639 – 767	786	797	800
					BP450	346 – 437	526	424	531.7	12C700C	616 – 739	756	767	770
					BPR450	346 – 437	526	424	531.7	12C800C	639 – 767	786	797	800
					B500	391 – 494	594	477	599.2					
					B600	439 – 555	668	537	673.4					
					BP300	265 – 334	402	324	406.4					
					BP350	300 – 378	455	366	459.2					
					BP400	313 – 396	476	383	481.0					
					BP450	346 – 437	526	424	531.7					
					B700C	517 – 625	835	677	850					
					B800C	647 – 817	965	783	983					
					12B700C	517 – 625	835	677	850					
					12B800C	647 – 817	965	783	983					

## Cable and Wiring Recommendations

					Minimum Spacing in Inches Between Classes — Steel Conduit/Tray					
Category	Wiring Class	Signal Definition	Signal Examples	Cable Type	1	2/3/4	5/6	7/8	9/10/11	Spacing Notes
Power	1	AC power (600V or greater)	2.3kV 3/Ph AC lines	per NEC & local codes	0	3/9	3/9	3/18	Note 6	1/2/5
	2	AC power (less than 600V)	460V 3/Ph AC lines	per NEC & local codes	3/9	0	3/6	3/12	Note 6	1/2/5
	3	AC power	AC motor	per NEC & local codes						
Control	5	115V AC/DC logic	Relay logic/PLC I/O motor thermostat	per NEC & local codes	3/9	3/6	0	3/9	Note 6	1/2/5
		115V AC power	Power supplies, instruments							
	6	24V AC/DC logic	PLC I/O	per NEC & local codes						
Signal (Process)	7	Analog signals, DC supplies	Reference/feedback signal, 5 to 24V DC	Shielded cable — Belden 8735, 8737, 8404	3/18	3/12	3/9	0	1/3	2/3/4/5
		Digital (low speed)	TTL							
	8	Digital (high speed)	I/O, encoder, counter pulse tack	Shielded cable — Belden 9728, 9730						
Signal (Comm)	9	Serial communications	RS-232, 422 to terminals and printers	Shielded cable — Belden RS-232 — 8735, 8737 RS-422 — 9729, 9730	Note 6			1/3	0	
	11	Serial communications (greater than 20k baud)	PLC Remote I/O, PLC Data Highway	Twinaxial Cable — A – B 1770 CD						

### Example

Spacing relationship between 480V AC incoming power leads and 24V DC logic leads.

- 480V AC leads are class 2; 24V DC leads are class 6.
- For separate steel conduits, the conduits must be 76 mm (3 inches) apart.
- In a cable tray, the two groups of leads are to be 152 mm (6 inches) apart

### Spacing Notes

1. Both outgoing and return current carrying conductors are to be pulled in the same conduit or laid adjacent in tray.
2. Cables of the following classes can be grouped together.
  - Class 1: equal to or above 601 volts
  - Classes 2, 3, and 4 may have their respective circuits pulled in the same conduit or layered in the same tray.
  - Classes 5 and 6 may have their respective circuits pulled in the same conduit or layered in the same tray.

**Note:** Bundle may not exceed conditions of NEC310.

- Classes 7 and 8 may have their respective circuits pulled in the same conduit or layered in the same tray.

**Note:** Encoder cables run in a bundle may experience some amount of EMI coupling. The circuit application may dictate separate spacing.

- Classes 9, 10, and 11 may have their respective circuits pulled in the same conduit or layered in the same tray. Communication cables run in a bundle may experience some amount of EMI coupling and corresponding communications faults. The application may dictate separate spacing.
3. All wires of classes 7 through 11 must be shielded per the recommendations.
  4. In cable trays, steel separators are advisable between the class groupings.
  5. If conduit is used, it must be continuous and composed of magnetic steel.
  6. Spacing of communication cables classes 2 through 6 is:

Volts	Conduit Spacing	Through Air
115	1 inch	2 inches
230	1.5 inches	4 inches
460/575	3 inches	8 inches
575	proportional to 6 inches per 1000 volts	proportional to 12 inches per 1000 volts

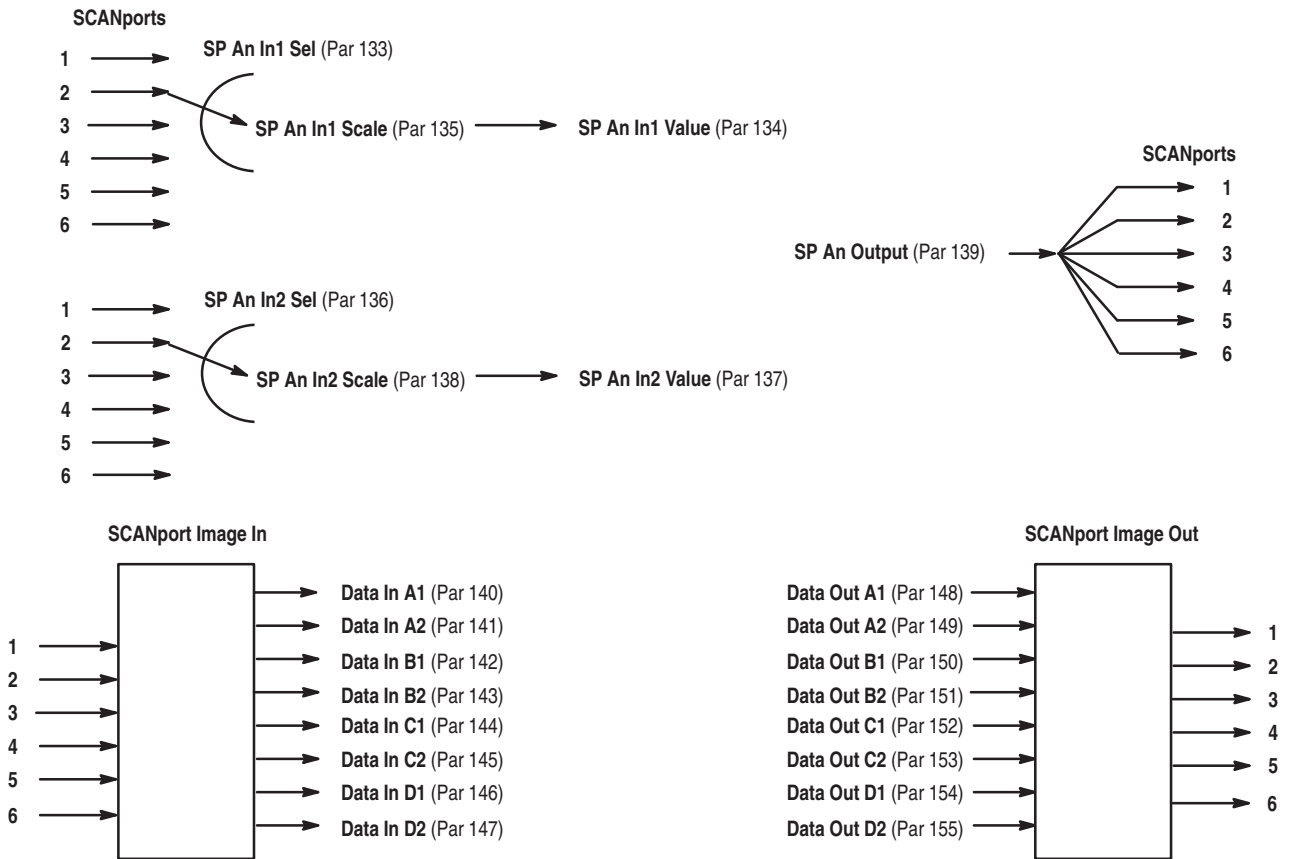
### General Notes

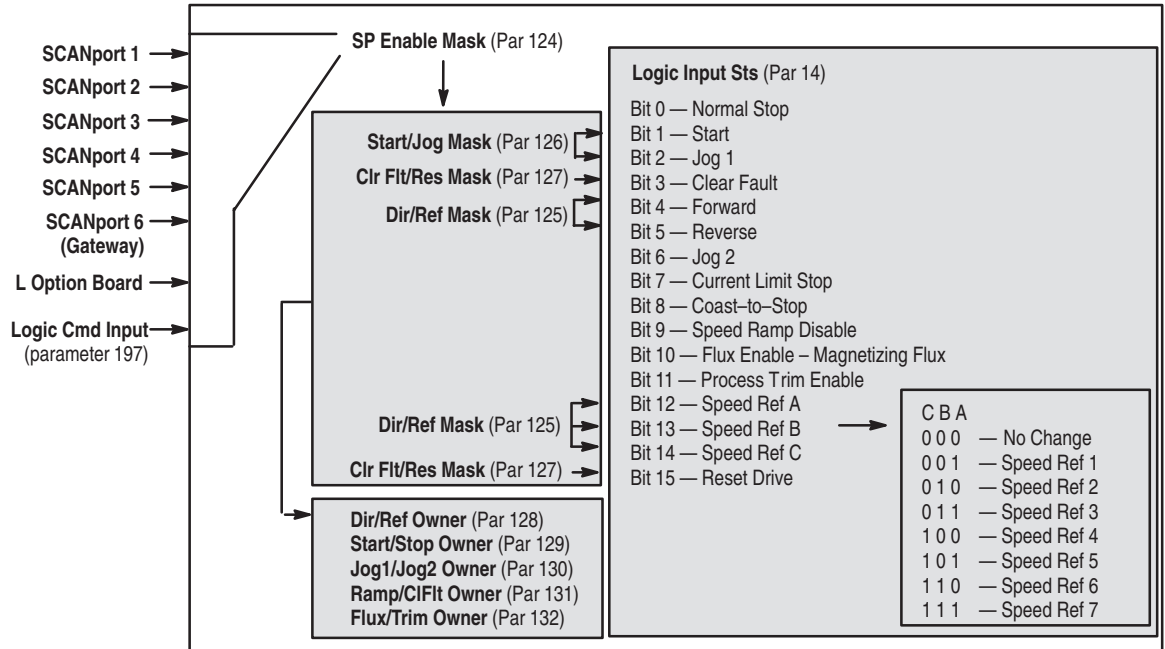
- Steel conduit is recommended for all wiring classes (Classes 7 – 11).
- Spacing shown between classes is the minimum required for parallel runs less than 400 feet. Greater spacing should be used where possible.
- Shields for shielded cables must be connected at one end only. The other end should be cut back and insulated. Shields for cables from a cabinet to an external device must be connected at cabinet end. Shields for cables from one cabinet to another must be connected at the source end cabinet. Splicing of shielded cables, if absolutely necessary, should be done so that shields remain continuous and insulated from ground.
- Power wire is selected by load. 16 AWG is the minimum recommended size for control wiring.

## Software Block Diagram

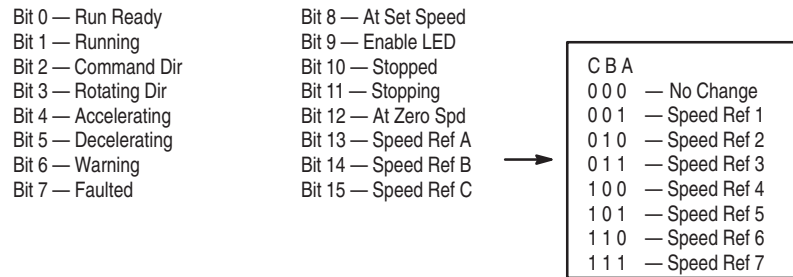
The following figures show the parameter linking and interactions within the 1336 IMPACT drive. For more information about parameter linking, refer to Chapter 6, *Starting Up Your System*.

SCANport



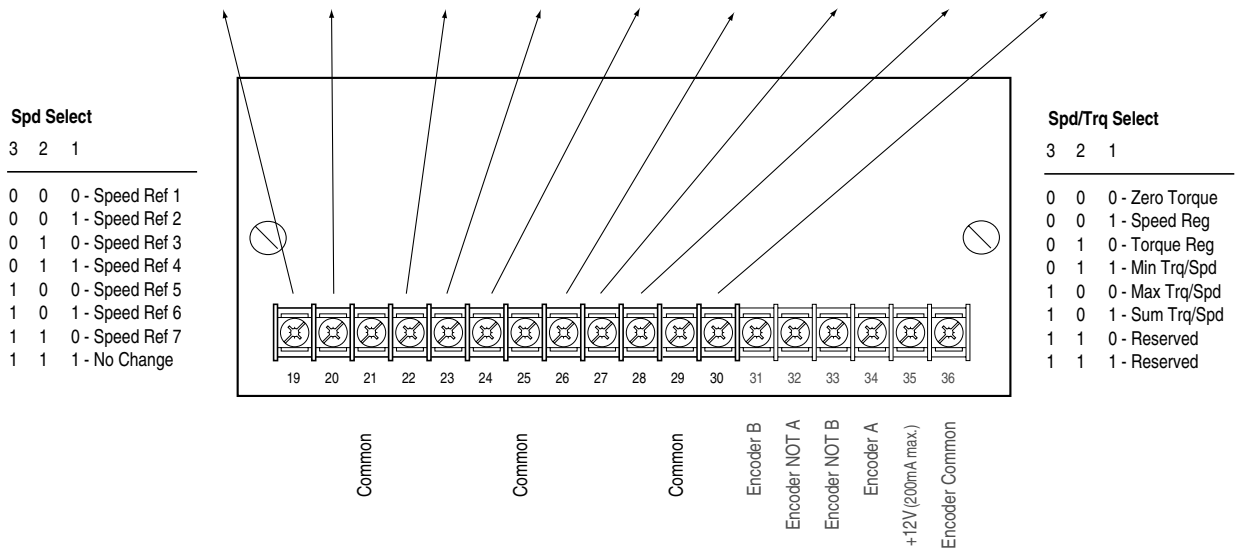


**Drive/Inv Status (Par 15)**



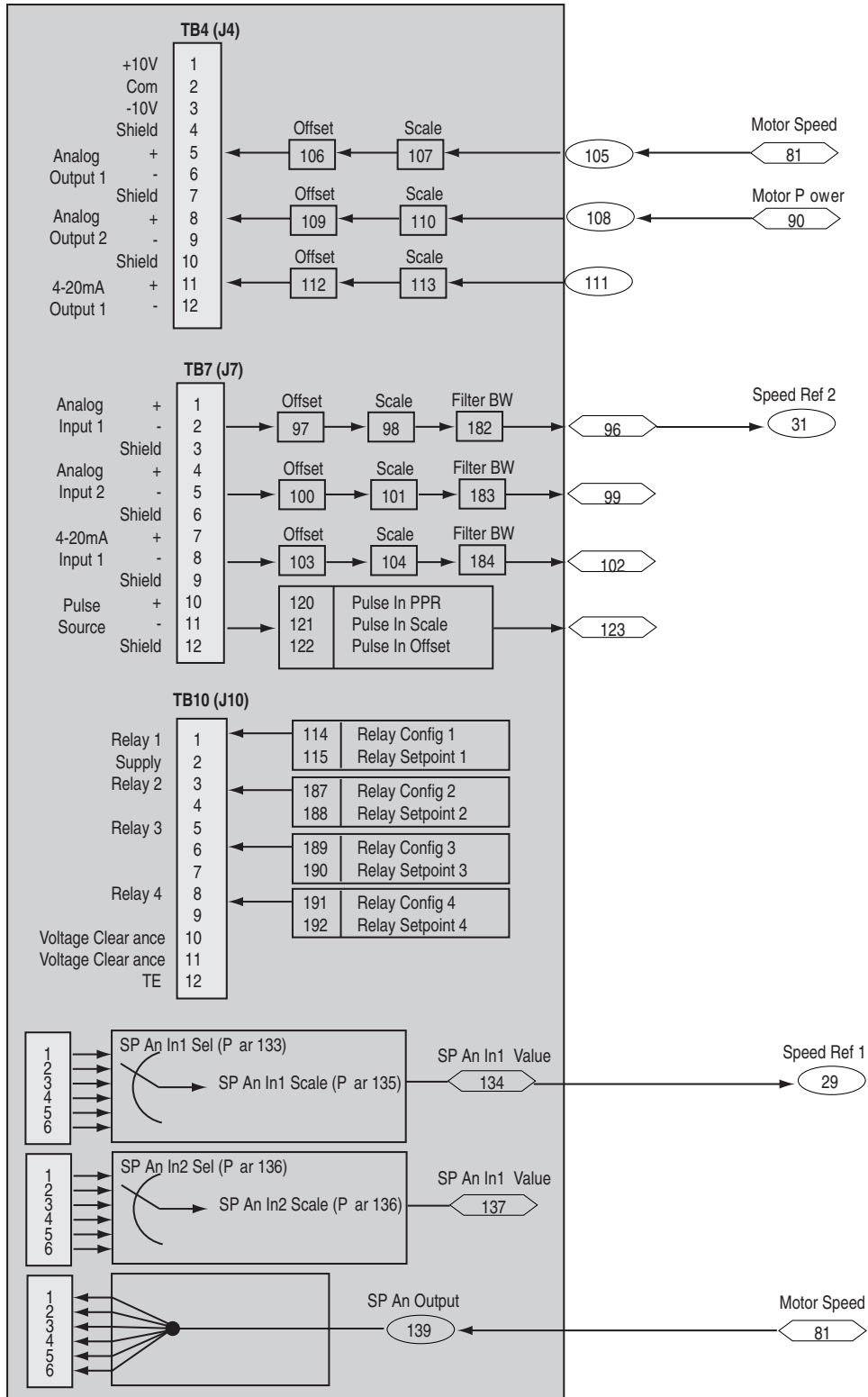
### L Option

1	Status	Stop/Clr Flt	Status	Status	Status	Status	Status	Status	Enable
2	Start	Stop/Clr Flt	Rev/Fwd	Jog	Ext Flt	Spd Sel 3	Spd Sel 2	Spd Sel 1	Enable
3	Start	Stop/Clr Flt	Rev/Fwd	Stop Type	Ext Flt	Spd Sel 3	Spd Sel 2	Spd Sel 1	Enable
4	Start	Stop/Clr Flt	Rev/Fwd	Accel 2*/1	Ext Flt	Decel 2*/1	Spd Sel 2	Spd Sel 1	Enable
5	Start	Stop/Clr Flt	Rev/Fwd	MOP Incr	Ext Flt	MOP Decr	Spd Sel 2	Spd Sel 1	Enable
6	Start	Stop/Clr Flt	Rev/Fwd	Jog	Ext Flt	Loc/Rem	Spd Sel 2	Spd Sel 1	Enable
7	Start	Stop/Clr Flt	Reverse	Forward	Ext Flt	Jog	Spd Sel 2	Spd Sel 1	Enable
8	Start	Stop/Clr Flt	Reverse	Forward	Ext Flt	Spd Sel 3	Spd Sel 2	Spd Sel 1	Enable
9	Start	Stop/Clr Flt	MOP Incr	MOP Decr	Ext Flt	Spd Sel 3	Spd Sel 2	Spd Sel 1	Enable
10	Start	Stop/Clr Flt	Reverse	Forward	Ext Flt	MOP Incr	MOP Decr	Spd Sel 1	Enable
11	Start	Stop/Clr Flt	Accel 1	Accel 2	Ext Flt	Decel 1	Decel 2	Spd Sel 1	Enable
12	Run Fwd	Stop/Clr Flt	Run Rev	Loc/Rem	Ext Flt	Spd Sel 3	Spd Sel 2	Spd Sel 1	Enable
13	Run Fwd	Stop/Clr Flt	Run Rev	Stop Type	Ext Flt	Spd Sel 3	Spd Sel 2	Spd Sel 1	Enable
14	Run Fwd	Stop/Clr Flt	Run Rev	Accel 2*/1	Ext Flt	Decel 2*/1	Spd Sel 2	Spd Sel 1	Enable
15	Run Fwd	Stop/Clr Flt	Run Rev	MOP Incr	Ext Flt	MOP Decr	Spd Sel 2	Spd Sel 1	Enable
16	Run Fwd	Stop/Clr Flt	Run Rev	Loc/Rem	Ext Flt	Stop Type	Spd Sel 2	Spd Sel 1	Enable
17	Start	Stop/Clr Flt	Rev/Fwd	PTrim En	Ext Flt	Ramp Dis	Spd Sel 2	Spd Sel 1	Enable
18	Start	Stop/Clr Flt	Rev/Fwd	Flux Enable	Ext Flt	Reset	Spd Sel 2	Spd Sel 1	Enable
19	Start	Stop/Clr Flt	Spd/Trq 3	Spd/Trq 2	Ext Flt	Spd/Trq 1	PTrim En	Spd Sel 1	Enable
20	Start	Stop/Clr Flt	Spd/Trq 3	Spd/Trq 2	Ext Flt	Spd/Trq 1	Flux Enable	Spd Sel 1	Enable
21	Start	Stop/Clr Flt	Reverse	Forward	Ext Flt	Ramp Dis	Reset	Spd Sel 1	Enable
22	Start	Stop/Clr Flt	Spd/Trq 3	Spd/Trq 2	Ext Flt	Spd/Trq 1	Spd Sel 2	Spd Sel 1	Enable
23	Run Fwd	Stop/Clr Flt	Run Rev	PTrim En	Ext Flt	Reset	Spd Sel 2	Spd Sel 1	Enable
24	Run Fwd	Stop/Clr Flt	Run Rev	Flux Enable	Ext Flt	Reset	Spd Sel 2	Spd Sel 1	Enable
25	Run Fwd	Stop/Clr Flt	Run Rev	PTrim En	Ext Flt	Ramp Dis	Spd Sel 2	Spd Sel 1	Enable
26	Run Fwd	Stop/Clr Flt	Run Rev	Jog	Ext Flt	Spd Sel 3	Spd Sel 2	Spd Sel 1	Enable
27	Start	Stop/Clr Flt	Rev/Fwd	MOP Incr	Ext Flt	MOP Decr	Spd Sel 2	Spd Sel 1	Enable
28	Start	Stop/Clr Flt	MOP Incr	MOP Decr	Ext Flt	Spd Sel 3	Spd Sel 2	Spd Sel 1	Enable
29	Start	Stop/Clr Flt	Reverse	Forward	Ext Flt	MOP Incr	MOP Decr	Spd Sel 1	Enable
30	Run Fwd	Stop/Clr Flt	Run Rev	MOP Incr	Ext Flt	MOP Decr	Spd Sel 2	Spd Sel 1	Enable
31	Step Trig	Stop/Clr Flt	Step Trig	Step Trig	Ext Flt	Step Trig	Step Trig	Step Trig	Enable
32	Start	Stop/Clr Flt	Step Trig	Step Trig	Ext Flt	Profile Ena	Run Seq	Pos Hold	Enable



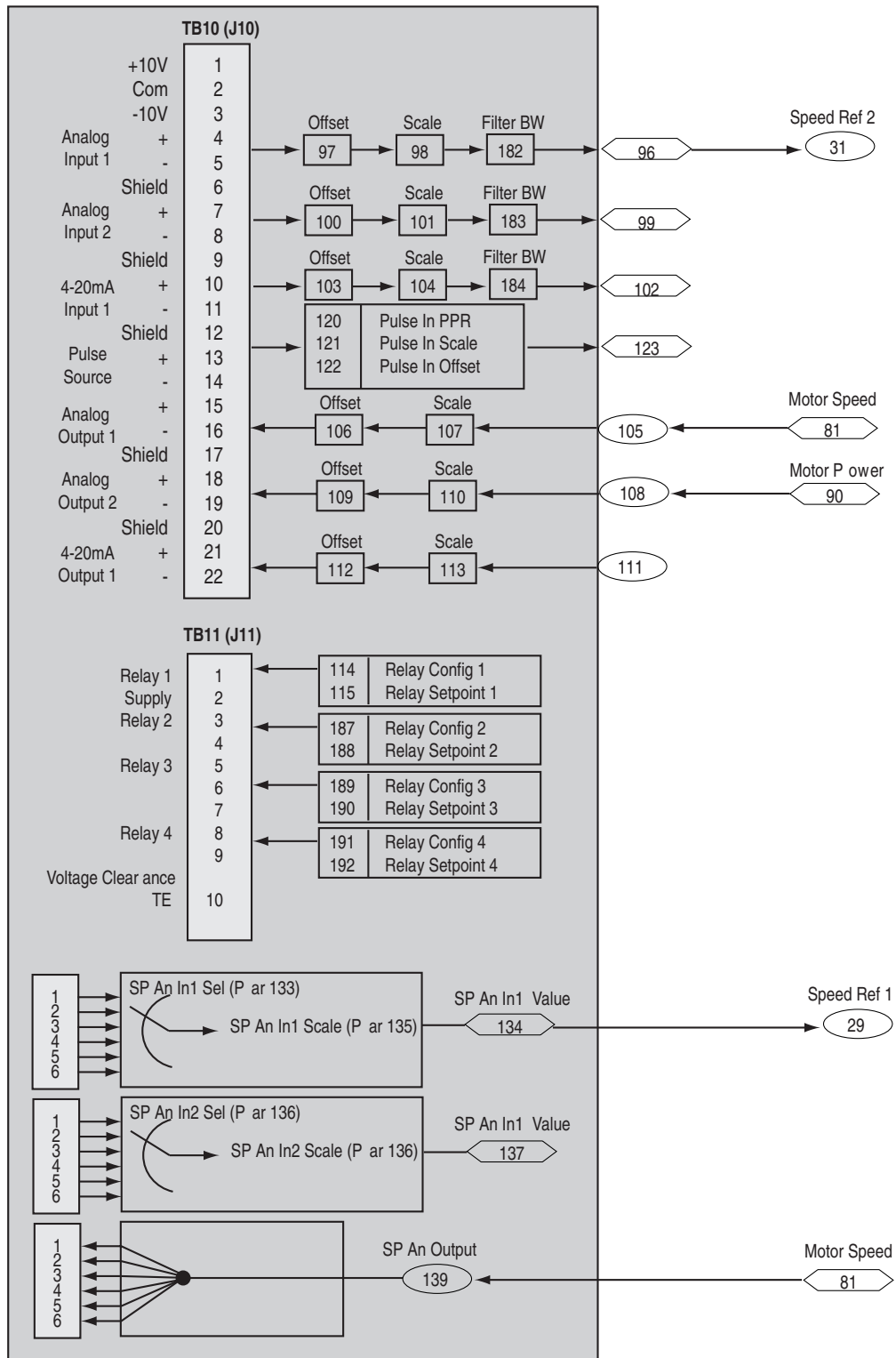
In modes 5, 9, 10, and 15, the MOP value is not reset to 0 when you stop. In modes 27, 28, 29, and 30, the MOP value is reset to 0 when you stop.

### Analog I/O Parameters for Frames A1 – A4





### Analog I/O Parameters for Frames B – H



**Notes:**






## Control Block Diagrams

### Chapter Objectives

Appendix B provides descriptions of the control block diagrams.

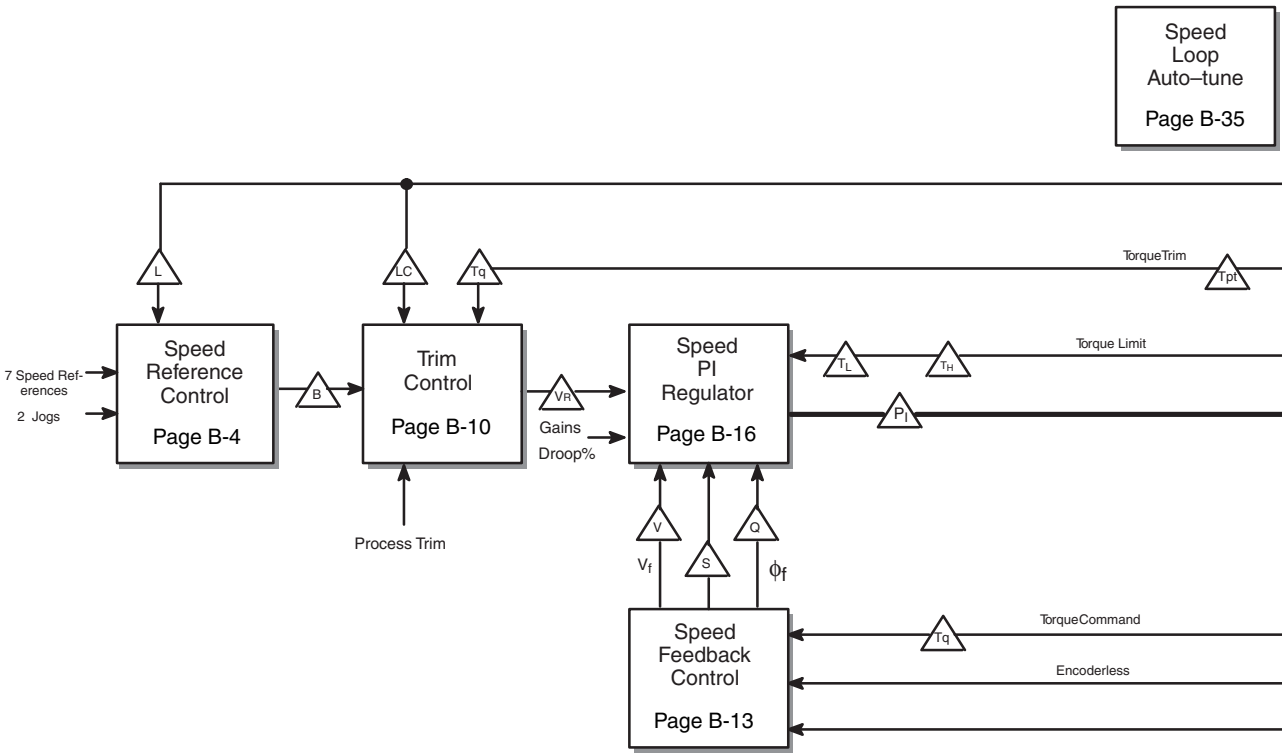
The overview of this topic:	Starts on page:
Motor control board	B-2
Speed reference selection	B-4
Trim control	B-10
Speed feedback	B-13
Speed PI regulator	B-16
Torque reference	B-19
Torque block	B-24
Drive fault detection	B-27
Inverter overload	B-32
Speed loop auto-tune	B-35
Through-put time	B-38

Throughout this appendix:

This symbol:	Indicates:
	A source parameter.
	A destination parameter.
	A particular bit. For example, the following symbols identify bit 6 (Jog Ramp En) in <i>Logic Options</i> :  

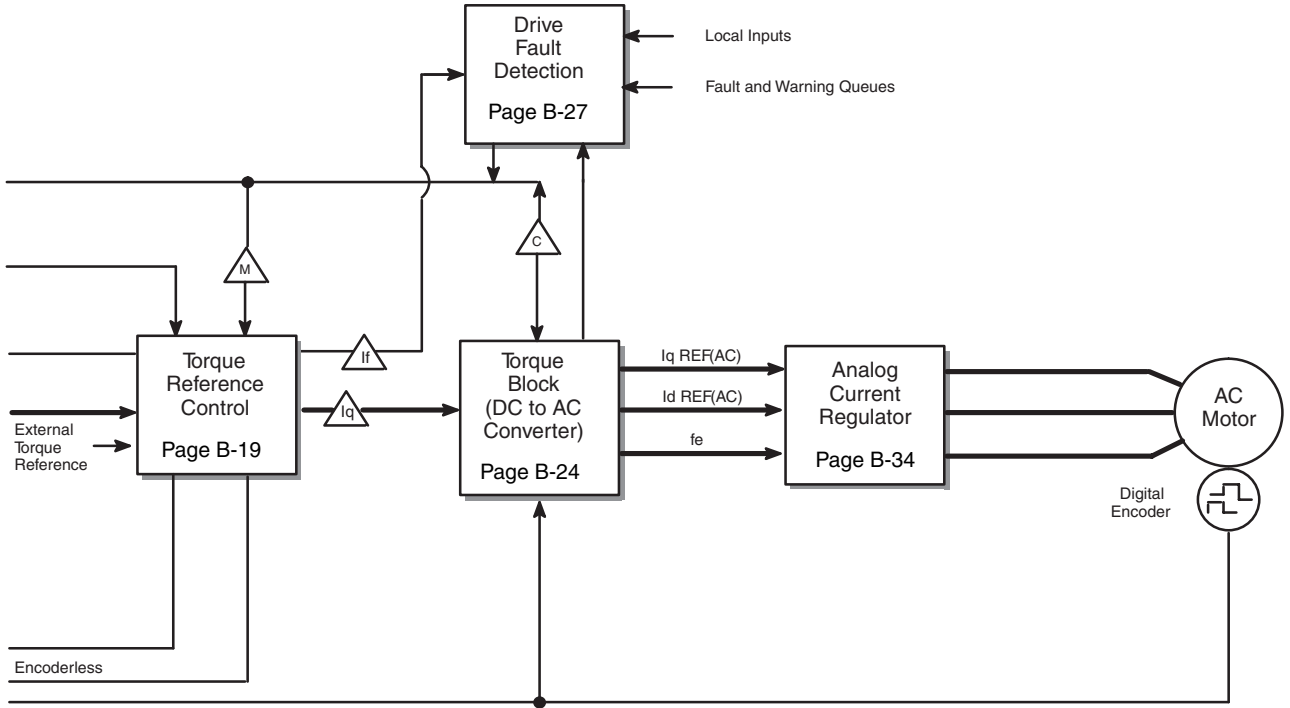
# Motor Control Board Overview

The following is an overview of how the drive processes information.



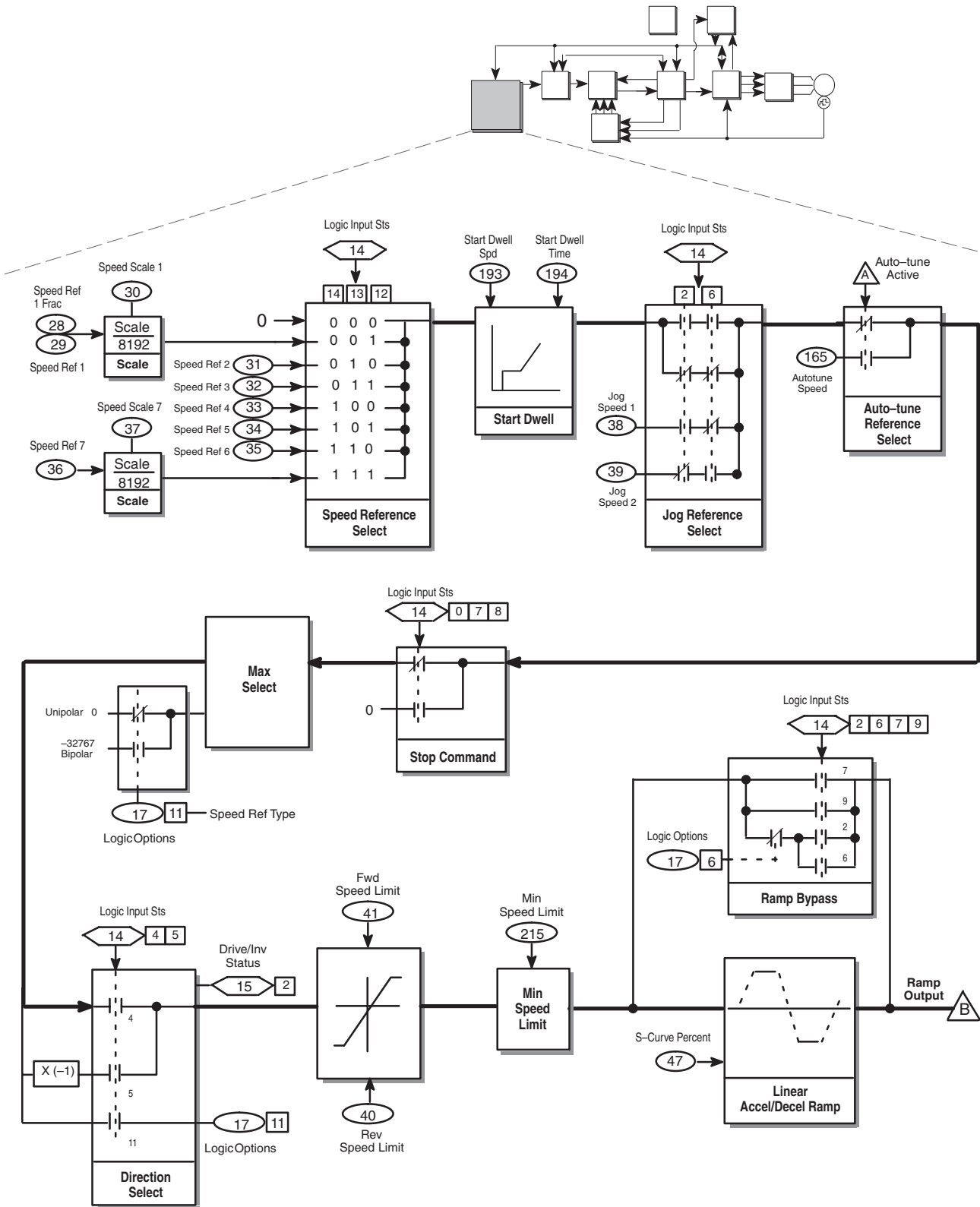
## Sheet Connection Symbols

- |  |                           |  |                           |  |                          |
|--|---------------------------|--|---------------------------|--|--------------------------|
|  | Speed Ramp Output         |  | Speed PI Regulator Output |  | Speed Reference          |
|  | Current Processor Command |  | φ <sub>f</sub>            |  | Torque Trim              |
|  | Filtered Is Reference     |  | Speed Trim                |  | Trim Error               |
|  | Iq Reference              |  | Torque Limit High         |  | Stator Current Reference |
|  | Active Logic Command      |  | Torque Limit Low          |  |                          |
|  | Logic Control Word        |  | Torque Command            |  |                          |
|  | Active Torque Mode        |  | Speed Feedback            |  |                          |



# Speed Reference Selection Overview

You can use the following block diagram to view how the drive uses the various speed reference selection parameters to determine the speed and direction that the drive should run.



*file:* Control  
*group:* Speed Reference

## Selecting the Speed and Jog References

Multiple parameters can affect the speed and jog references. These parameters are as follows:

This parameter group:	Is represented by parameters:	And has this function:
Speed Reference	28, 29, and 31 through 36	Supplies the speed references that the drive should use.
Speed Scale Factor	30 and 37	Sets the gain multiplier that is used to scale the speed references.
Jog Speed	38 and 39	Sets the jog speed reference.

*file:* Monitor  
*group:* Drive/Inv Status

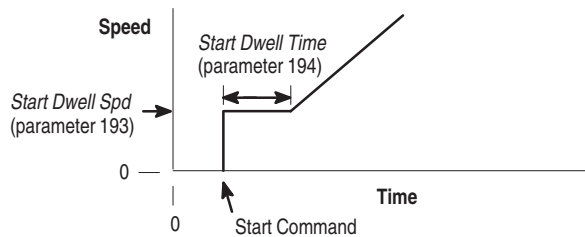
When determining the speed reference, bits 12, 13, and 14 of *Logic Input Sts* (parameter 14) identify which speed reference or preset speed parameter is used:

If bit 14 is:	And bit 13 is:	And bit 12 is:	Then, the speed reference is:
0	0	0	Zero
0	0	1	Speed Ref 1
0	1	0	Speed Ref 2
0	1	1	Speed Ref 3
1	0	0	Speed Ref 4
1	0	1	Speed Ref 5
1	1	0	Speed Ref 6
1	1	1	Speed Ref 7

Likewise, when determining the jog reference, bits 2 and 6 of *Logic Input Sts* identify which jog speed parameter is used.

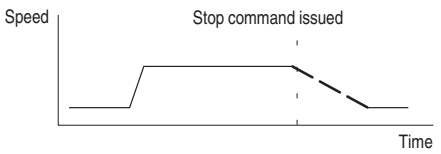
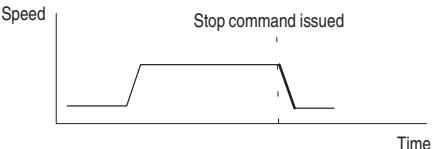
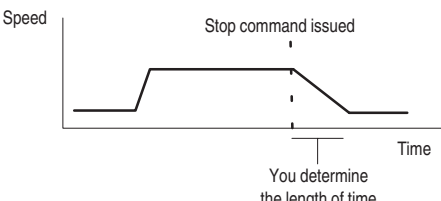
## Using a Start Dwell

You can use *Start Dwell Spd* (parameter 193) and *Start Dwell Time* (parameter 194) to set the speed and the length of time that the drive should immediately output when a start command is issued. Once the specified time has elapsed, the drive ramps to the speed you selected in speed reference 1 through 7.



## Choosing a Stop Command

You need to specify how you want the drive to stop the motor when a stop command is issued. You have three options:

This type of stop:	Is specified in this bit of Logic Input Sts:	And can be represented by the following diagram:
Coast	8	 <p>This results in inverter shut off.</p>
Current Limit	7	 <p>This results in the fastest possible stop.</p>
Normal (Ramp)	0	

By default, the normal stop (bit 0) is used.

To view which type of stop is currently selected for your drive, check to see which bit of Logic Input Sts is set (0, 7, or 8). If multiple bits are set, the priority is bit 8 (coast stop), bit 7 (current limit stop), and then bit 0 (normal stop).



*The braking method, if any, that you have selected also affects how your drive stops. Refer to Chapter 9, Applications, and the description of Bus/Brake Opts (parameter 13) in Chapter 11, Parameters, for information about the available braking methods.*



## Choosing a Direction



For motors, forward and reverse are arbitrary directions. For this section, forward is considered counterclockwise from the shaft end of the motor.

*file:* Control  
*group:* Drive Logic Select

The 1336 IMPACT drive lets you change whether the motor is rotating in a forward or reverse motion. The direction depends on whether or not bit 11 of *Logic Options* (parameter 17) is set for unipolar or bipolar:

If bit 11 is set for:	Then the drive receives references that are:	To change the direction you need to:	
Unipolar	All positive	Set the forward/reverse bit in the L Option card or command word. This bit is displayed in bits 4 (forward) and 5 (reverse) of <i>Logic Input Sts.</i>	
Bipolar	Positive and negative	Change the reference sign.	
		For this type of reference:	Use the following to change the reference sign:
		Analog	$\pm$ voltages
Digital	$\pm$ numbers		

*file:* Control  
*group:* Control Limits

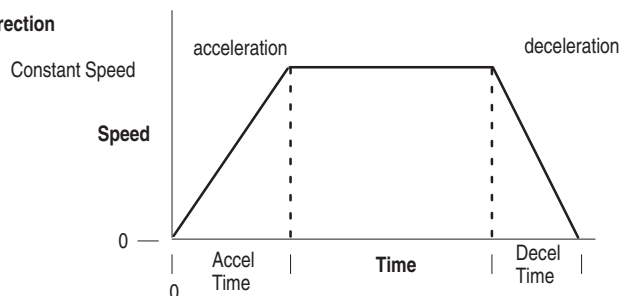
Regardless of how you change the direction, you can specify how fast the drive can go in either direction (forward or reverse). To do this, you need to set the maximum values in *Fwd Speed Limit* (parameter 41) and *Rev Speed Limit* (parameter 40).

You can also specify the minimum speed at which you want the drive to run. To do this, enter the minimum speed in *Min Speed Limit* (parameter 215). When you set the minimum speed, you can still go from a positive reference to a negative reference. When you press the stop button, the speed will go down to zero.

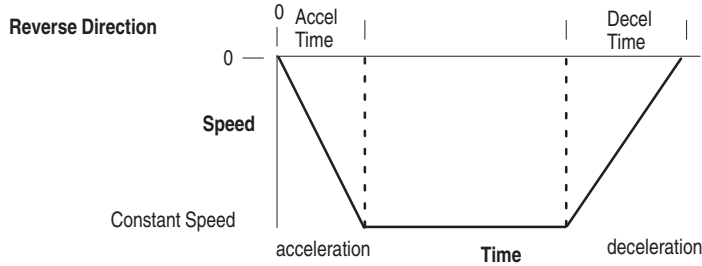
## Using the Speed Ramps

The 1336 IMPACT drive lets you set the acceleration and deceleration ramps by specifying how long you want the drive to go from 0 rpm to the base speed and from the base speed back to 0 rpm.

### Forward Direction



Acceleration and deceleration are relative terms. Acceleration refers to a change in speed away from 0 rpm, and deceleration is a change in speed towards 0 rpm. For example, the acceleration time could be used to get the speed more negative:



file: Control  
group: Accel/Decel

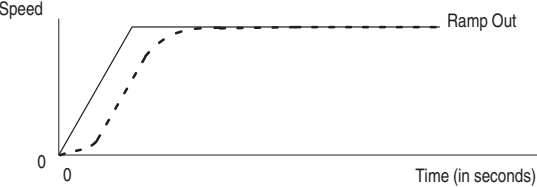
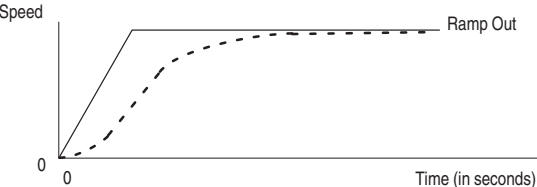
You can use *Accel Time 1* (parameter 42) and *Accel Time 2* (parameter 43) to change the acceleration ramp and *Decel Time 1* (parameter 44) and *Decel Time 2* (parameter 45) to change the deceleration ramp.

▶ *If your system does not have a brake, the bus regulator limits Decel Time 1 to prevent a bus overvoltage situation from occurring.*

▶ *Accel Time 2 and Decel Time 2 are only available if you have an L Option board and you have set L Option Mode (parameter 116) to 4, 11, or 14.*

You can use *S-Curve Percent* (parameter 47) to control the level of filtering that is applied to the acceleration and deceleration ramps.

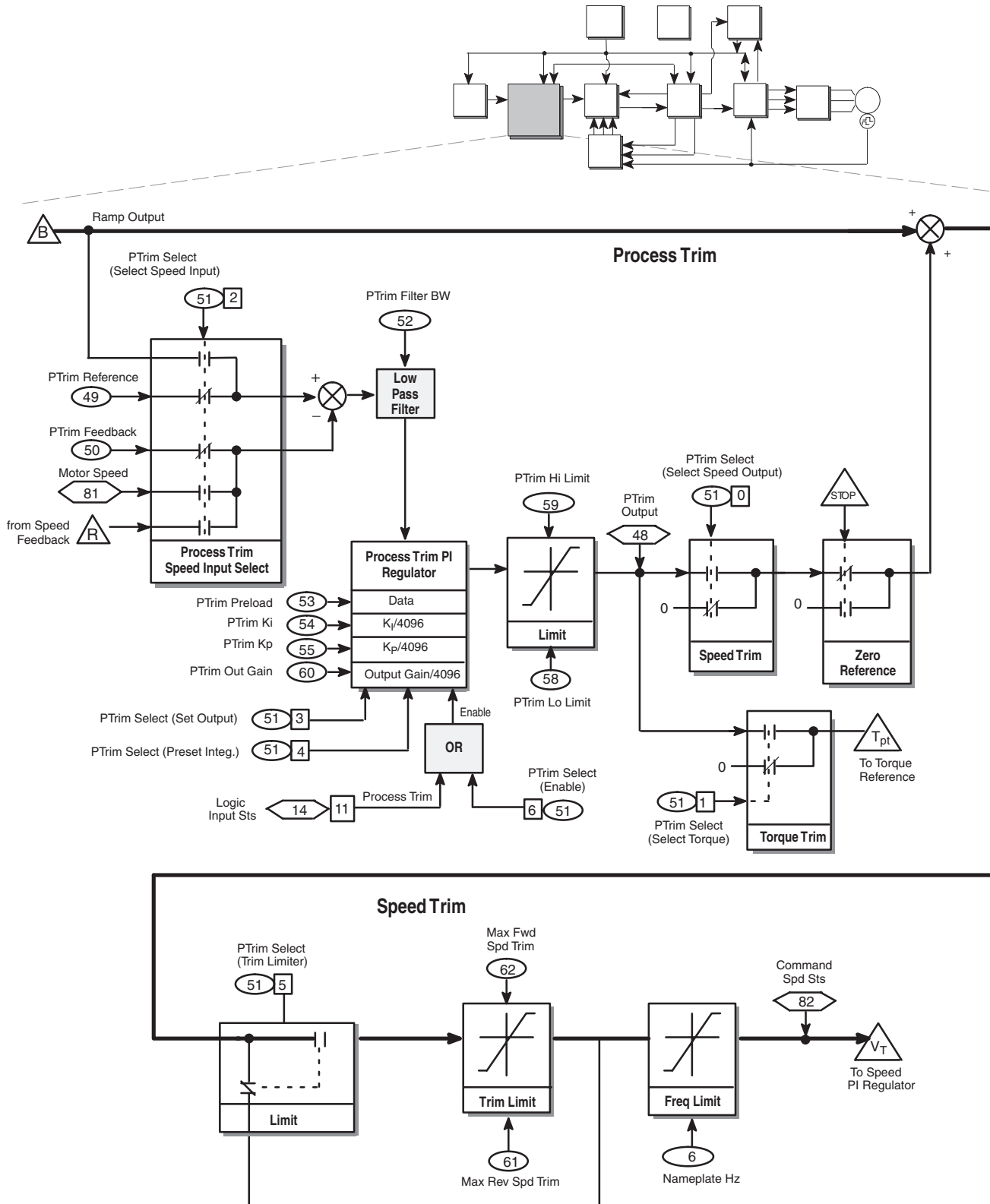
If <i>S-Curve Percent</i> is set to:	Then:
0%	<p>No S-curve is used.</p>
10%	<p>The S-curve is applied to 10% of the ramp time.</p>

If S-Curve Percent is set to:	Then:
50%	<p>The S-curve is applied to 50% of the ramp time.</p> 
100%	<p>The S-curve is applied to 100% of the ramp time.</p> 

To by-pass the acceleration and deceleration ramps, use a communications module or an L Option board to set bit 9 of *Logic Input Sts* (parameter 14). You can also by-pass the ramps by setting the appropriate Accel/Decel Time parameters (parameters 42, 43, 44, and 45) to zero.

### Trim Control Overview

You can use the following block diagram to view how the drive uses the process trim parameters to modify the speed and torque reference values that the motor uses.



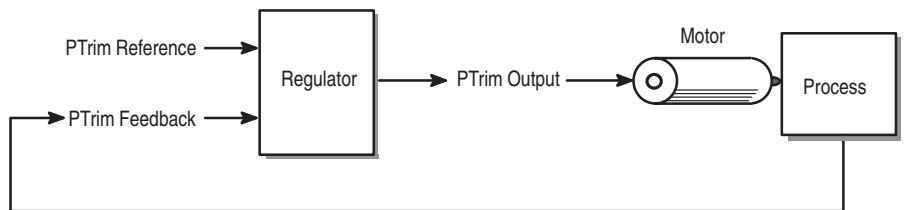
*file:* Application  
*group:* Process Trim

## Understanding Process Trim

Process trim lets you adjust the speed or torque of the motor. *PTrim Reference* (parameter 49) contains the setpoint input for the processor under control. *PTrim Feedback* (parameter 50) contains the input for the process variable that is being controlled. These values are compared. The regulator adjusts *PTrim Output* (parameter 48) so that the difference between *PTrim Reference* and *PTrim Feedback* approaches 0.

Figure B.1 shows the process trim cycle.

**Figure B.1**  
**Process Trim**



The process trim PI (proportional integral) regulator takes inputs from *PTrim Preload* (parameter 53), *PTrim Ki* (parameter 54), *PTrim Kp* (parameter 55), and *PTrim Select* (parameter 51).

*PTrim Select* lets you select specific options for the process trim regulator. The following options are available:

To select this option:	Set this bit:
Trim the speed reference.	0
Trim the torque reference.	1
Configure as outer speed trim loop. Set bit 2 to pre-configure the <i>PTrim Reference</i> (parameter 49) and <i>PTrim Feedback</i> (parameter 50) values to use the speed ramp output and speed feedback signals.	2
Set output option. When you set bit 3, the output follows <i>PTrim Preload</i> (parameter 53) with the process trim enable bit off. Rise of process trim enable will preset the integral term of the process trim regulator to start the <i>PTrim Output</i> (parameter 48) at the data input value.	3
Preset integrator option. When you set bit 4, <i>PTrim Output</i> is zero with the process trim enable bit off. Rise of enable will preset the integrator as in option bit 3.	4
Force ON trim limit option. When you set bit 5, the speed trim limit function is always active. When clear (bit 5 = 0), the speed trim limiter is automatically disabled.	5
Enable process trim.	6
Enable Encoder Switchover Mode	7

If bits 3 and 4 are both clear (0), *PTrim Output* (parameter 48) becomes zero with the enable bit off and the integral term is initialized at zero. If bits 3 and 4 are both set (1), option 3 (set output option) takes priority.

The limit function lets you select the minimum and maximum values.

To enter the:	Enter a value in this parameter:
Minimum level	<i>PTrim Lo Limit</i> (parameter 58)
Maximum level	<i>PTrim Hi Limit</i> (parameter 59)

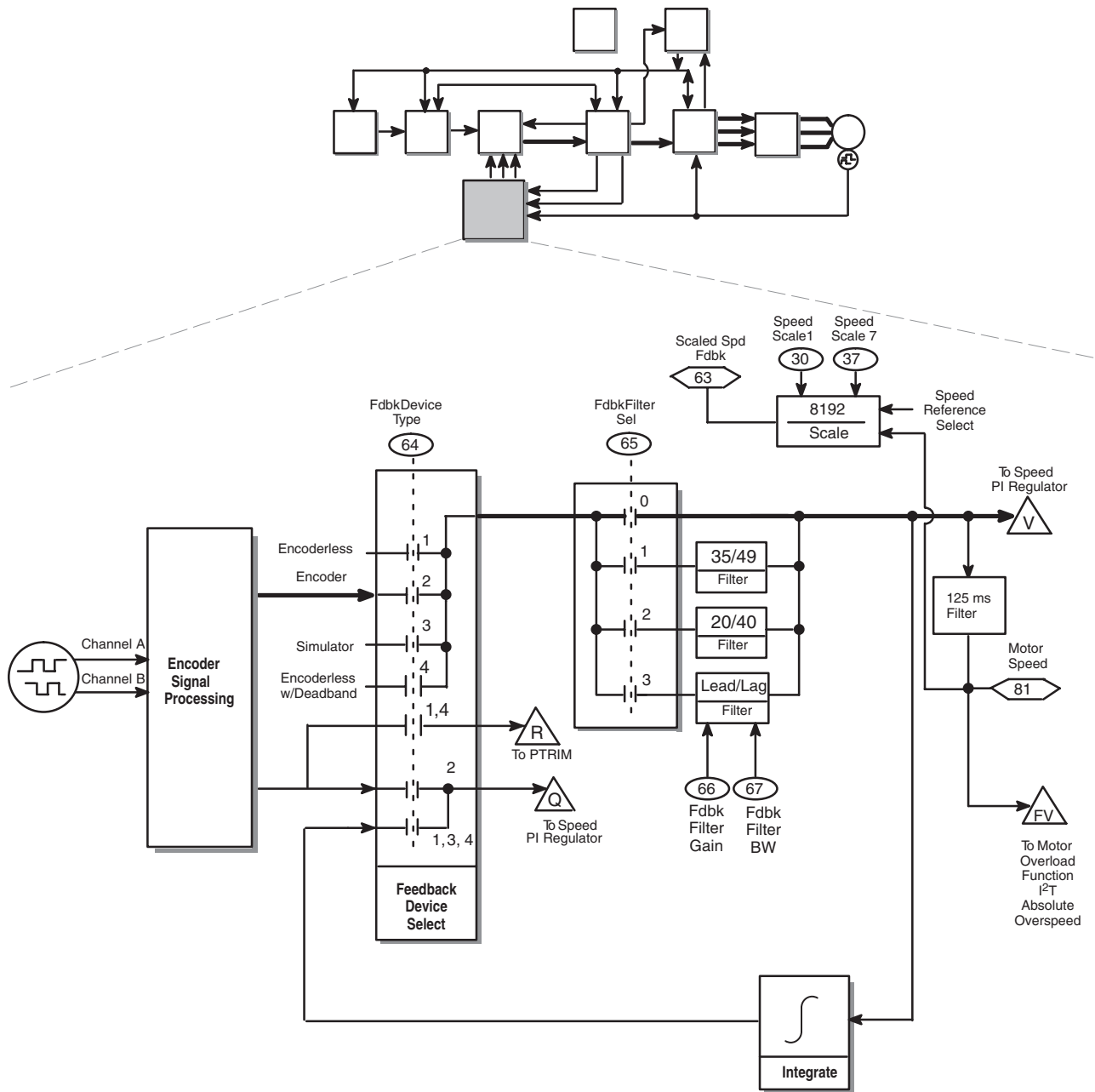
Once the value leaves the limit function, PTrim Select (parameter 51) determines whether the value is used as a speed trim or a torque trim.

If this bit is set:	Then:
0	The speed reference is used.
1	The torque reference is used.
Both bit 0 and bit 1	Both the speed and the torque references remain unaffected.
Neither bit 0 nor bit 1	

### Understanding Encoder Switchover

### Speed Feedback Overview

You can use the following block diagram to view how the drive uses the speed feedback parameters.



### Selecting Your Feedback Device Type

You can use *Fdbk Device Type* (parameter 64) to choose your feedback device type. You have the following options:

*file:* Control  
*group:* Feedback Device

If you want to use this feedback device type:	Select this value:
Encoderless. This is the default feedback device.	1
Encoder. Encoders are only available through the L Option board.	2
Motor simulation. This is useful for testing drive operation and interface checkout when the motor is not available or cannot be used.	3

If you want to use this feedback device type:	Select this value:
Encoderless w/dead band. Limits operation of drive below a reference value of 1Hz. Drive Speed and torque regulators are clamped at zero when speed reference is less than 1 Hz.	4

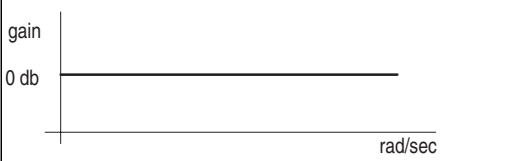
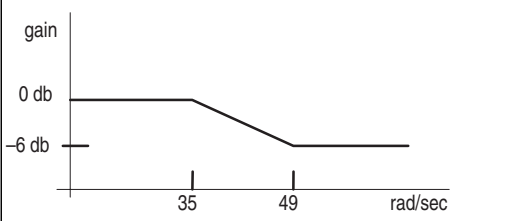
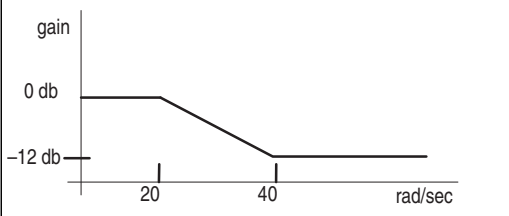
Refer to Chapter 9, *Applications*, for additional information about the feedback device type selections.

**Important:** Even though *Fdbk Device Type* lets you change the feedback device type, you should use the start up procedure to change your feedback device. The start up procedure automatically changes several related parameters, and changing *Fdbk Device Type* manually will not re-set these parameters.

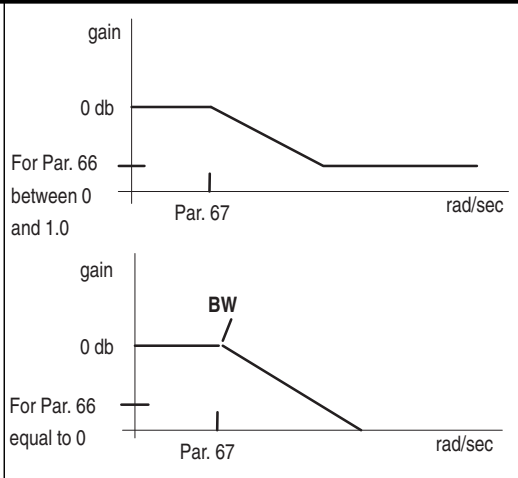
### Selecting Your Feedback Filter

You can use *Fdbk Filter Sel* (parameter 65) to select the type of feedback filter. You can choose among the following filters:

*file:* Control  
*group:* Speed Feedback

	To select this type of filter:	Select this value:
No filter	 <p>The plot shows gain on the y-axis (0 dB) and rad/sec on the x-axis. A horizontal line is drawn at 0 dB, indicating no frequency response change.</p>	0
A light 35/49 radian feedback filter	 <p>The plot shows gain on the y-axis (0 dB, -6 dB) and rad/sec on the x-axis (35, 49). The gain is 0 dB until 35 rad/sec, then decreases linearly to -6 dB at 49 rad/sec, and remains constant thereafter.</p>	1
A heavy 20/40 radian feedback filter	 <p>The plot shows gain on the y-axis (0 dB, -12 dB) and rad/sec on the x-axis (20, 40). The gain is 0 dB until 20 rad/sec, then decreases linearly to -12 dB at 40 rad/sec, and remains constant thereafter.</p>	2



	To select this type of filter:	Select this value:
A single pole lead/lag feedback filter	 <p>gain</p> <p>0 db</p> <p>For Par. 66 between 0 and 1.0</p> <p>Par. 67</p> <p>rad/sec</p> <p>gain</p> <p>0 db</p> <p>For Par. 66 equal to 0</p> <p>Par. 67</p> <p>rad/sec</p> <p><b>BW</b></p>	3

Notice that *Fdbk Filter Gain* (parameter 66) and *Fdbk Filter BW* (parameter 67) are used for the single pole lead/lag filter. *Fdbk Filter Gain* lets you specify the  $K_n$  term of the single power lead/lag filter.

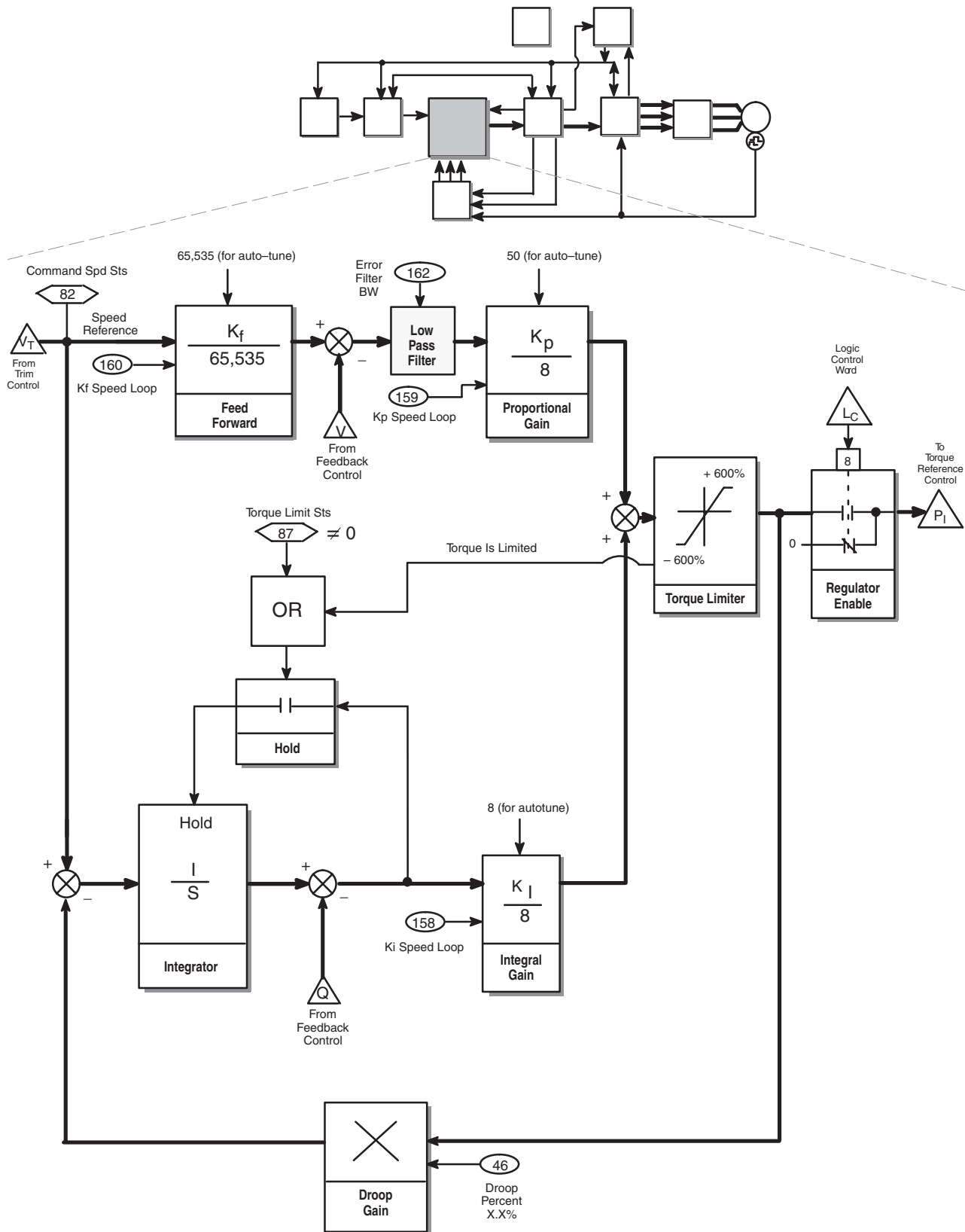
If $K_n$ is:	Then:
Greater than 1.0	A lead filter is produced.
Less than 1.0	A lag filter is produced.
Equal to 1.0	The feedback filter is disabled.
Equal to 0.0	A simple, low pass filter is produced.

*Fdbk Filter BW* lets you set the breakpoint frequency (in radians) for the speed feedback lead/lag filter. The breakpoint frequency is indicated by **BW**.

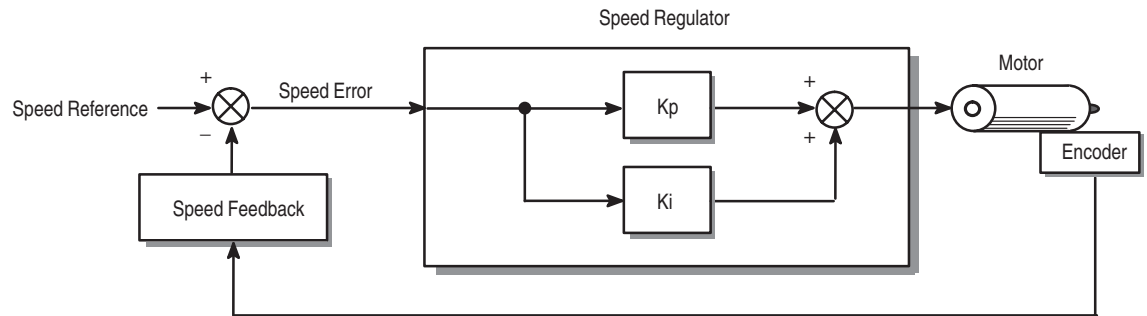
► A notch filter is also available through *Fdbk Filter Sel*. Information about the notch filter is provided in the *Torque Reference Overview* section of this appendix.

### Speed PI Regulator Overview

You can use the following block diagram to view how the drive uses the speed PI regulator parameters.



The 1336 IMPACT drive takes the speed reference that you specify to the drive and compares that value to the value of the speed feedback that is coming from the motor. The drive tries to make the two values match as close as possible by sending a speed error value to the speed PI regulator. The speed PI regulator uses the  $K_p$  (proportional) and  $K_i$  (integral) gains to adjust the torque reference value that is sent to the motor to try to get the actual speed of the motor as close to the speed you specified as possible. This can be shown as:



The  $K_p$  and  $K_i$  gains are set during the auto-tune procedure. Once you find gains that provide a good speed of response for your system without making your system unstable, you should not change the  $K_p$  and  $K_i$  parameters. The  $K_p$  and  $K_i$  gains are covered in the Inertia Test portion of Chapter 13, *Understanding the Auto-tuning Procedure*. The following information about  $K_p$  is also provided to show what happens if you are not using the proper gains for your system.

If $K_p$ is:	Then:
Too low	The response time decreases. This means that it takes the regulator a longer time to get the speed feedback value close to the speed reference value that you specified.
Too high	A torque ripple can be produced. If you have an encoder on your system, the torque ripple can be produced typically when $K_p$ is around 50. If you do not have an encoder on your system, the maximum is less than 50.
0	The speed PI regulator is strictly an integral regulator. This causes unstable operation.

The following information is provided about  $K_i$ :

If $K_i$ is:	Then:
Too low	The time that it takes to recover from a speed or load disturbance increases. This means that the regulator takes a longer time to get the speed feedback value close to the speed reference value that you specified.
Too high	Your system will not be stable, and it may oscillate.
0	The speed PI regulator is strictly a proportional regulator.

### Using the Kf Gain

In addition to the  $K_p$  and  $K_i$  gains, the speed PI regulator also uses a  $K_f$  gain. The  $K_f$  gain affects the speed overshoot in response to a step change in speed reference. You can adjust the  $K_f$  gain parameter at any time, independent from the proportional and integral gains without affecting the stability of the system.

Chapter 13, *Understanding the Auto-tuning Procedure*, provides more information about the  $K_f$  gain.

### Scaling the Speed Pi Regulator Gains

<i>file:</i> Control
<i>group:</i> Speed Regulator

*Kf Speed Loop* (parameter 160), *Kp Speed Loop* (parameter 159), and *Ki Speed Loop* (parameter 158) are available for scaling the gains. The scaling used for each of these parameters is in eighths ( $8 = 1.0$ ).

### Using the Error Filter Bandwidth

*Error Filtr BW* (parameter 162) provides a low-pass filter for applications that require more noise filtering. When using *Error Filtr BW*, keep the value of the parameter between 3 and 5 times greater than the value of *Spd Desired BW* (parameter 161), which represents the bandwidth of the speed loop.

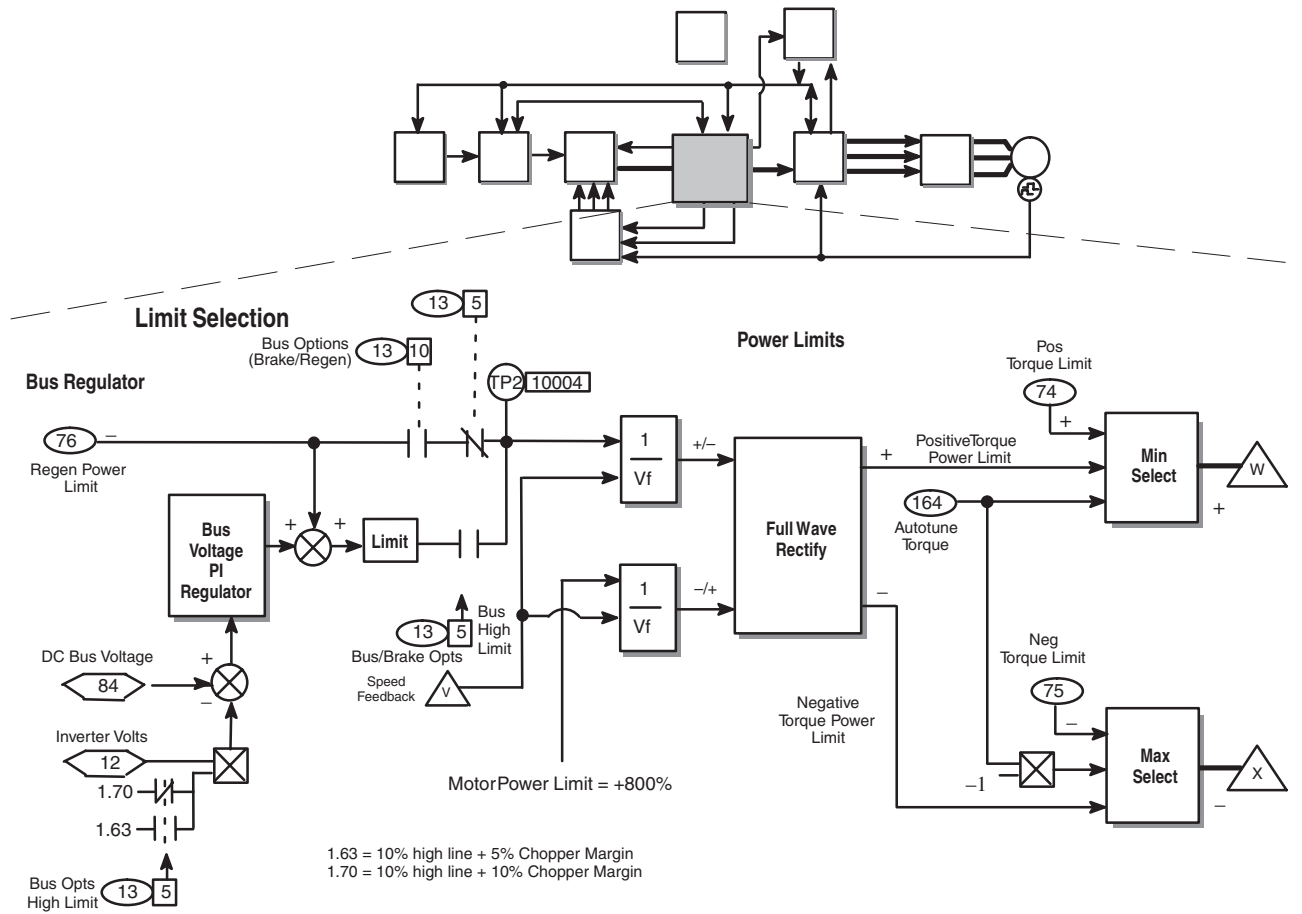
Additional information about *Error Filtr BW* is located in Chapter 13, *Understanding the Auto-tuning Procedure*.

### Adjusting the Motor Speed with Changes in Load (Droop Gain)

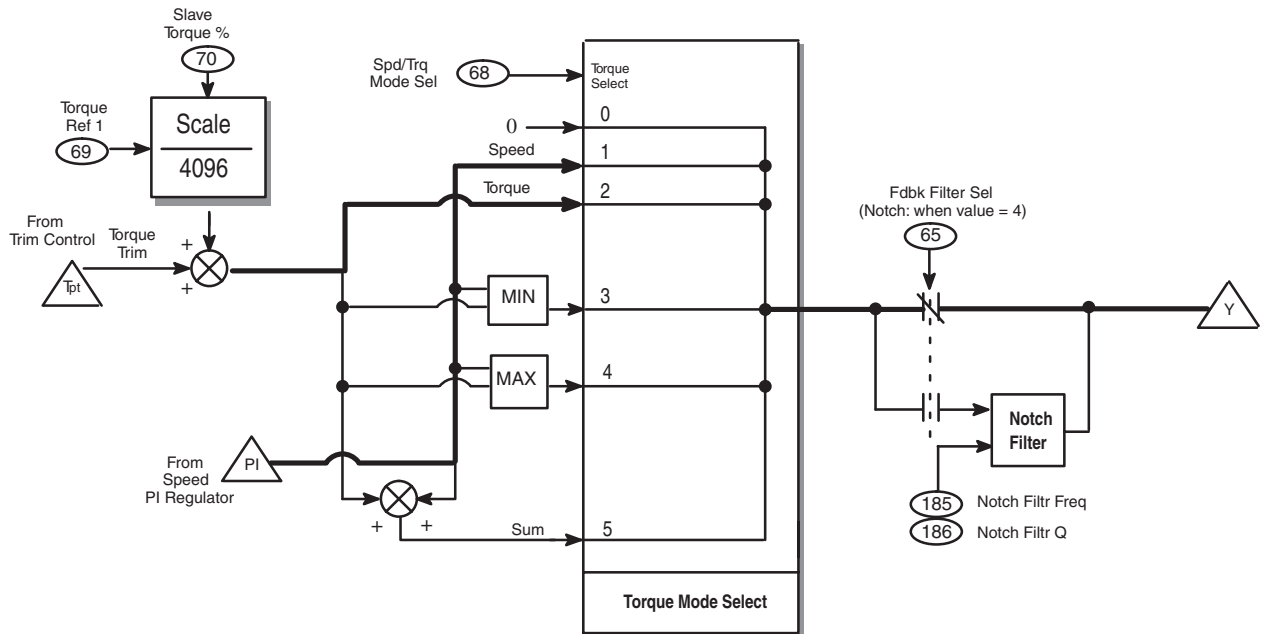
For some applications, you may want the motor speed to droop with an increase in load. In these cases, you can use *Droop Percent* (parameter 46) to specify the percent of base speed that the speed reference is reduced when at full load torque.

### Torque Reference Overview

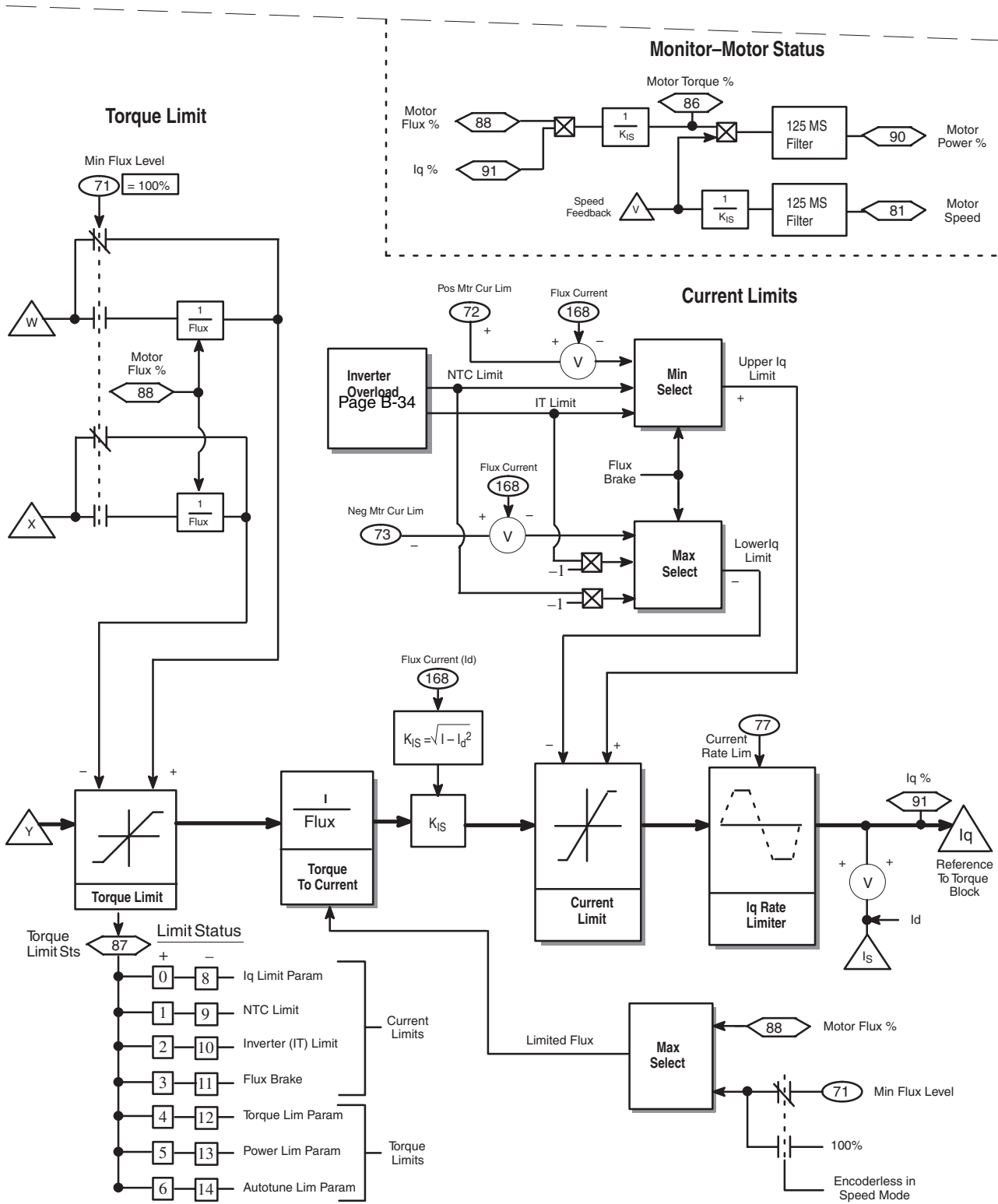
You can use the following block diagram to view how the drive uses the torque reference parameters.



### Torque Selection



Torque Reference Overview, Continued



The torque reference is divided into 6 areas: bus regulator, power limits, torque selection, torque limit, and monitor-motor status.

## Understanding the Bus Regulator

The bus regulator limits the maximum bus voltage for systems that do not have brake or regen (regenerative) capabilities.

<i>file:</i> Application
<i>group:</i> Bus Control

<i>file:</i> Control
<i>group:</i> Control Limits

<b>If bit 10 of <i>Bus/Brake Opts</i> (parameter 13) is:</b>	<b>Then:</b>
Set (1) to indicate that the system has a brake or regen capability	The drive uses the value of <i>Regen Power Lim</i> (parameter 76).
Clear (0) to indicate that the system does not have a brake or regen capability	The bus regulator limits the maximum bus voltage by automatically adjusting the value of <i>Regen Power Lim</i> . In this case, you should use a default value of -25%. If the drive system has significant losses, you can decrease this value until bus voltage faults occur.

Refer to Chapter 9, *Applications*, for more information on using the bus regulator for braking.

## Understanding the Power Limits

The power limits let you set limits on the maximum power limits in the positive and negative directions. Without these limits, you could receive a Bus Overvoltage Trip, which is a hardware fault.

The power limits first perform a full wave rectify to separate the input from the bus regulator into a positive value and a negative value. Once these values are separated, the minimum/maximum selection functions compare the values from the full wave rectify with the value of *Autotune Torque* (parameter 164) and the value of either *Pos Torque Lim* (parameter 74) or *Neg Torque Lim* (parameter 75) to determine which value is closest to zero (the most conservative value). The drive then passes the values to the torque limit function.

<i>file:</i> Autotune
<i>group:</i> Autotune Setup

<i>file:</i> Control
<i>group:</i> Control Limits

## Understanding the Torque Limit

The torque limit function uses the values it receives from the power limit function.

<b>If <i>Min Flux Level</i> (parameter 71) is:</b>	<b>The values are:</b>
Not 100%	Passed directly to the torque limit selector.
Set to 100%	Multiplied by 1/flux and <i>Motor Flux %</i> (parameter 88) is applied before the values are passed to the torque limit selector.

If a value is limiting the torque or current in either the positive or negative direction, a bit is set in *Torque Limit Sts* (parameter 87).

If this:	Is being limited by:	This bit is set for limits in this direction:	
		Positive	Negative
Current	The Iq limit parameters: <i>Pos Mtr Cur Lim</i> (parameter 72) or <i>Neg Mtr Cur Lim</i> (parameter 73)	0	8
	The NTC limit	1	9
	The Inverter (IT) limit	2	10
	Flux braking	3	11
Torque	The torque limit parameters: <i>Pos Torque Lim</i> (parameter 74) or <i>Neg Torque Lim</i> (parameter 75)	4	12
	The power limit parameters (from the bus regulator)	5	13
	The autotune limit parameters	6	14

### Understanding the Torque Selection

*Spd/Trq Mode Sel* (parameter 68) lets you select between speed mode and torque mode.

*file:* Control  
*group:* Speed/Trq Mode

*file:* Control  
*group:* Torque Reference

If you choose this mode:	Then your reference comes from:
Speed	The speed PI regulator.
Torque	The trim control and <i>Torque Ref 1</i> (parameter 69). You can also use <i>Slave Torque %</i> (parameter 70) to scale <i>Torque Ref 1</i> .

*Spd/Trq Mode Sel* provides the following options:

Set this bit:	If you want:
0	Zero torque to be used.
1	The source for the drive torque reference to come from the speed regulator.
2	The source for the drive torque reference to come from an external torque.
3	To compare the values of the speed regulator output with the torque reference sum and select the smaller value.
4	To compare the values of the speed regulator output with the torque reference sum and select the larger value.
5	To use the numeric sum of the speed regulator output plus the torque reference sum.

You can view the values of the speed regulator output and the torque reference sum.

To view the value of the speed regulator output:

1. Set *Test Select 2* (parameter 95) to 58220.
2. View the value of the speed regulator output in *Test Data 2* (parameter 94).

To view the value of the torque reference sum:

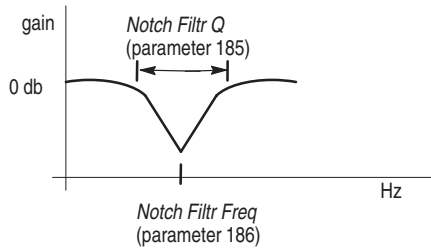
1. Set *Test Select 2* (parameter 95) to 9730.
2. View the value of the speed regulator in *Test Data 2* (parameter 94).

*file:* Monitor  
*group:* Testpoints



*file:* Control  
*group:* Speed Feedback

If *Fdbk Filter Sel* (parameter 65) is set to 4, then the output is passed through a notch filter before being used by the torque limit. *Notch Filtr Freq* (parameter 185) sets the center frequency for the 2 pole notch filter, and *Notch Filtr Q* (parameter 186) sets the quality factor. The following is an example of a notch filter.



*Other filters are available through Fdbk Filter Sel. These filters are covered in the Speed Feedback Overview section of this appendix.*

*file:* Control  
*group:* Control Limits

### Understanding the Current Limits

The current limit function uses a minimum and maximum selection routine to select the upper and lower  $I_q$  limits. The upper  $I_q$  limit is the lowest value when *Pos Mtr Cur Lim* (parameter 72), the NTC limit, and the IT limit are compared. The lower  $I_q$  limit is the largest value when *Neg Mtr Cur Lim* (parameter 73), the negative of the NTC limit, and the negative of the IT limit are compared.

The motor current limits affect the level of the total stator current ( $I_s$ ). To convert from stator current ( $I_s$ ) to torque current ( $I_q$ ), the flux current ( $I_d$ ) must be compensated for. This is done by subtracting *Flux Current* (parameter 168) from the motor current limit using vector math.

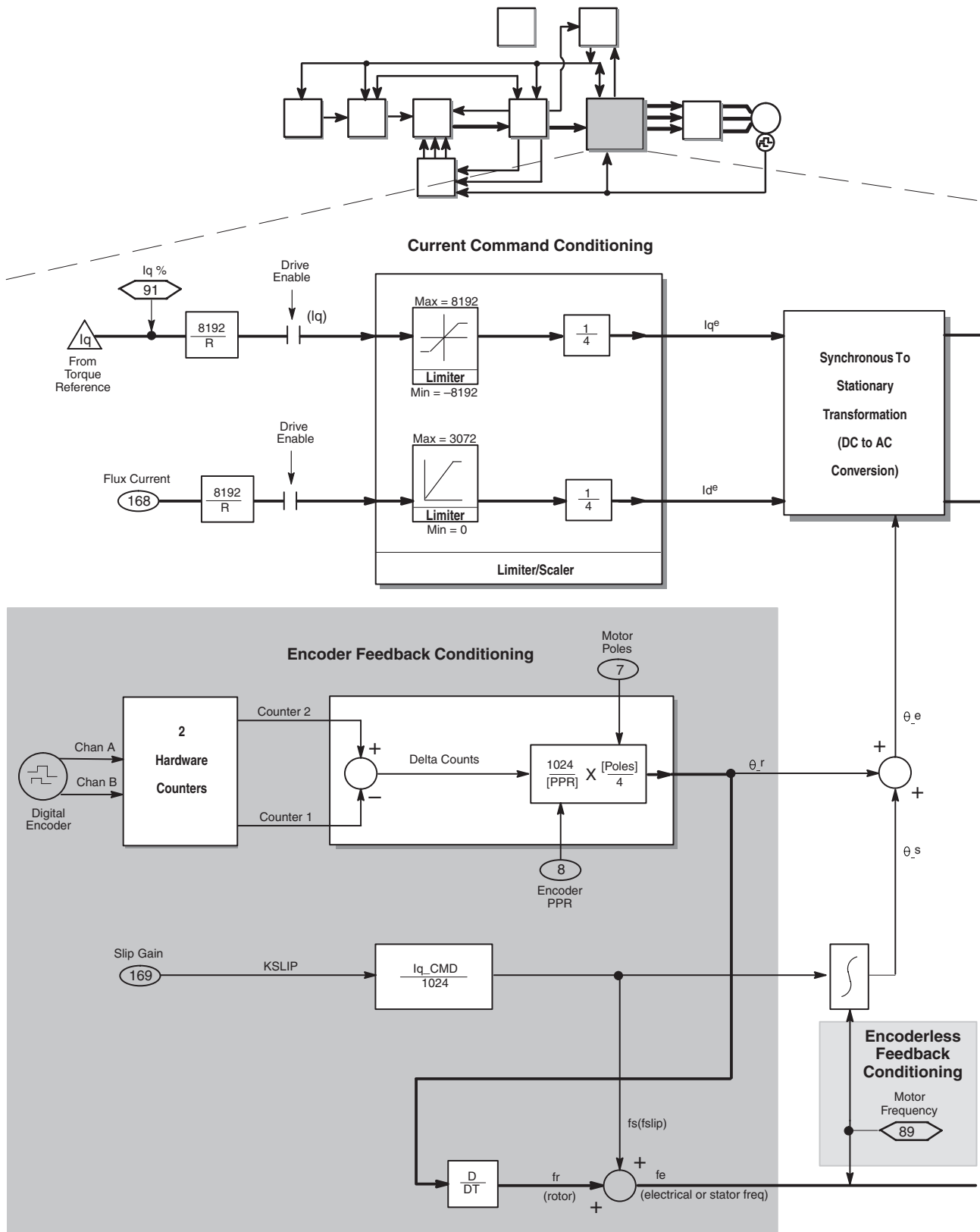
During flux braking, the  $I_q$  limit is reduced significantly to allow high levels of  $I_d$  current. A large  $I_d$  current is required for flux braking to occur.

### Understanding the Monitor-Motor Status

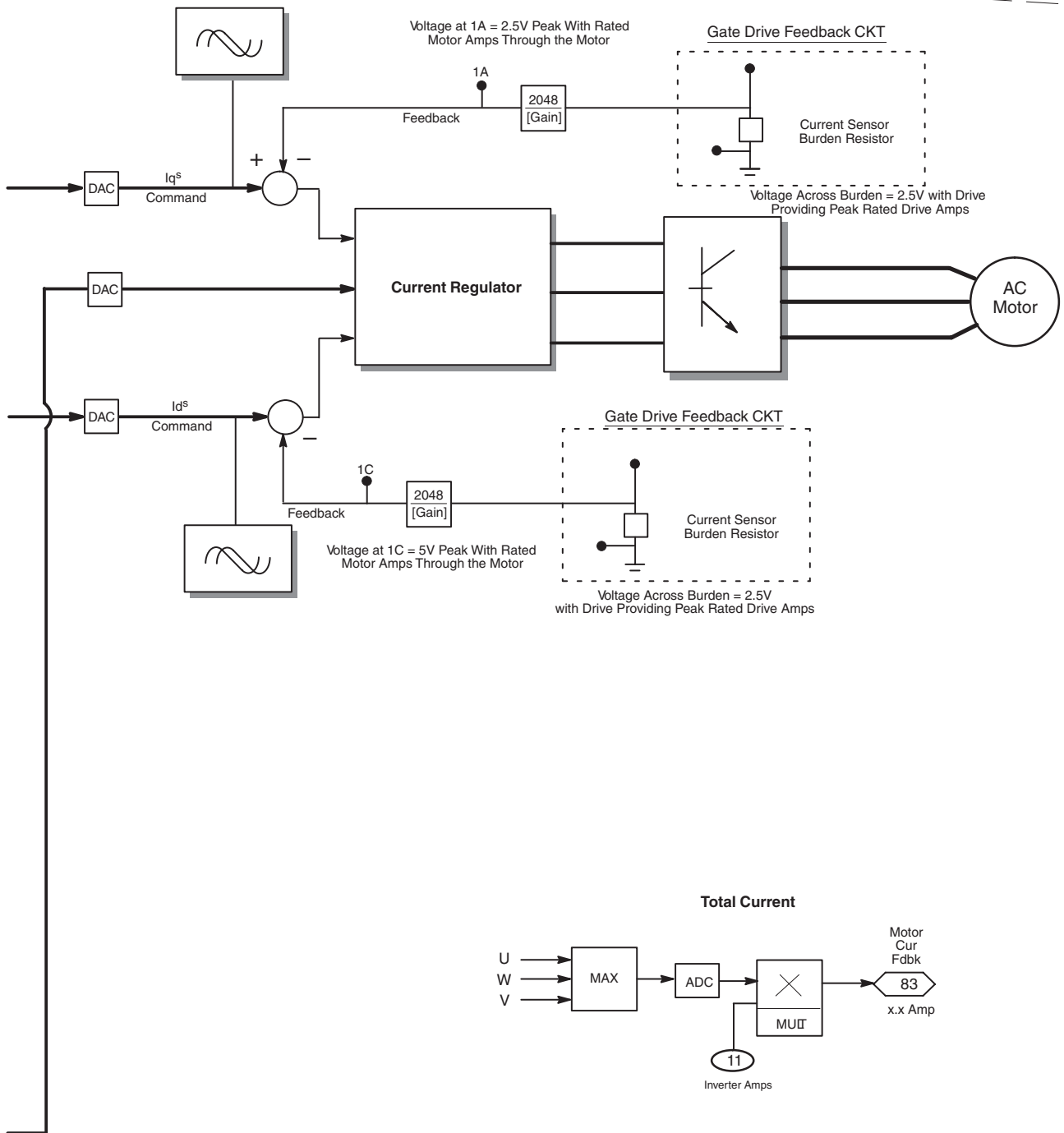
The monitor-motor status parameters are available for you to view the values of various power-related functions. Positive values indicate motoring power, and negative values indicate regenerative power.

### Torque Block Overview

You can use the following block diagram to view how the drive uses the torque block parameters.



Torque Block Overview, Continued



*file:* Motor/Inverter  
*group:* Motor Constants

The Limiter/Scaler function takes input from *Iq %* (parameter 91), the torque reference, and *Flux Current* (parameter 168) and performs limit checks and scaling on the two values. The Limiter/Scaler function outputs the synchronous (or electrical) values of the torque command ( $I_{qe}$ ) and the flux current ( $I_{de}$ ).

*file:* Monitor  
*group:* Motor Status

These values,  $I_{qe}$  and  $I_{de}$ , are converted to stationary values. To convert the values, the conversion routine also takes input from the feedback device.

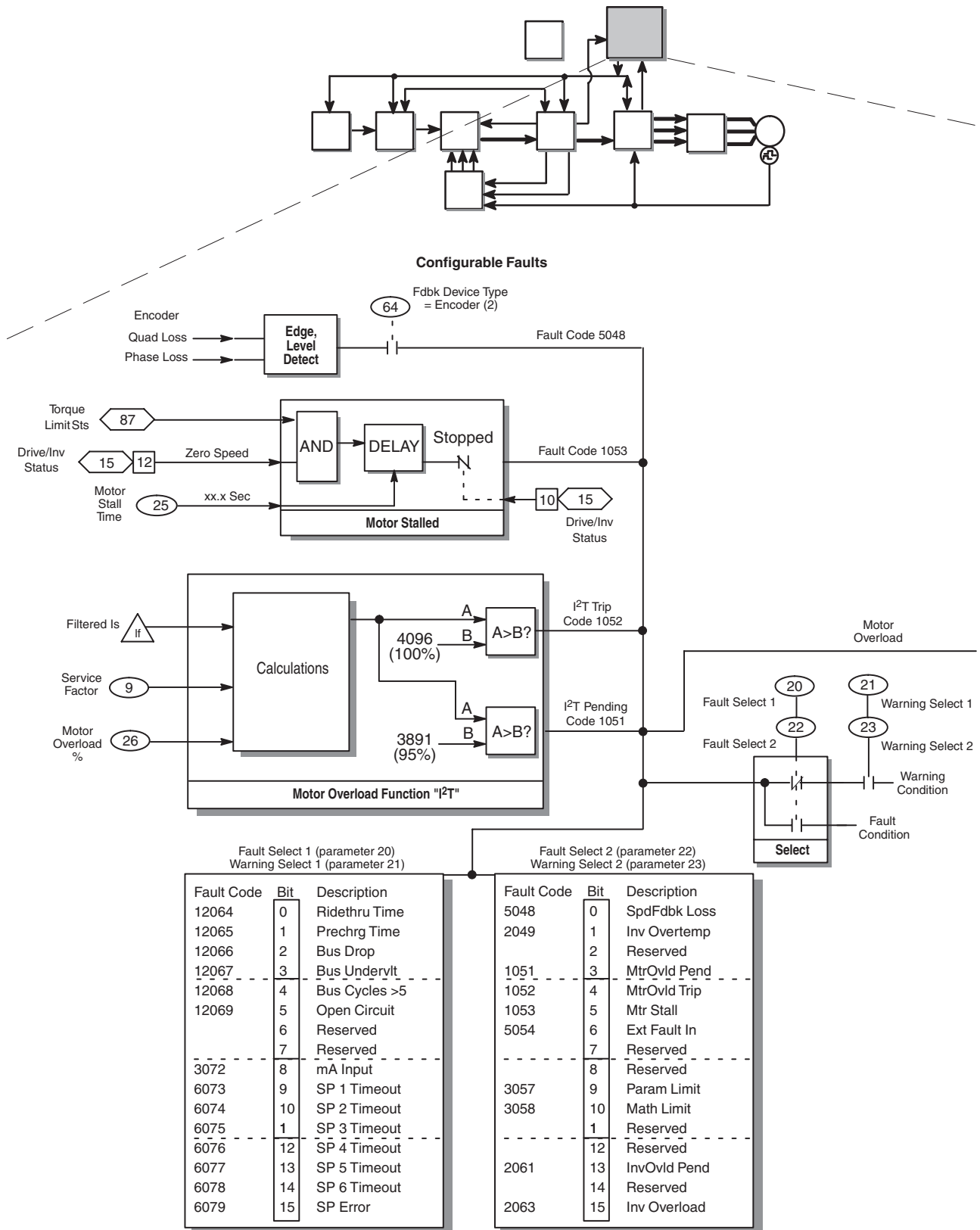
*file:* Motor/Inverter  
*group:* Motor Nameplate  
 Encoder Data

<b>If the feedback device is:</b>	<b>Then:</b>
Encoderless	The value of <i>Motor Frequency</i> (parameter 89) is integrated to get the proper units and then used for the conversion.
Encoder	The drive uses the values of <i>Motor Poles</i> (parameter 7) and <i>Encoder PPR</i> (parameter 8) to adjust the value coming from the encoder. The value of <i>Slip Gain</i> (parameter 169) is integrated to get the proper units and then added to the value from the encoder.

Once the values are converted to stationary values, they are sent to the current regulator.

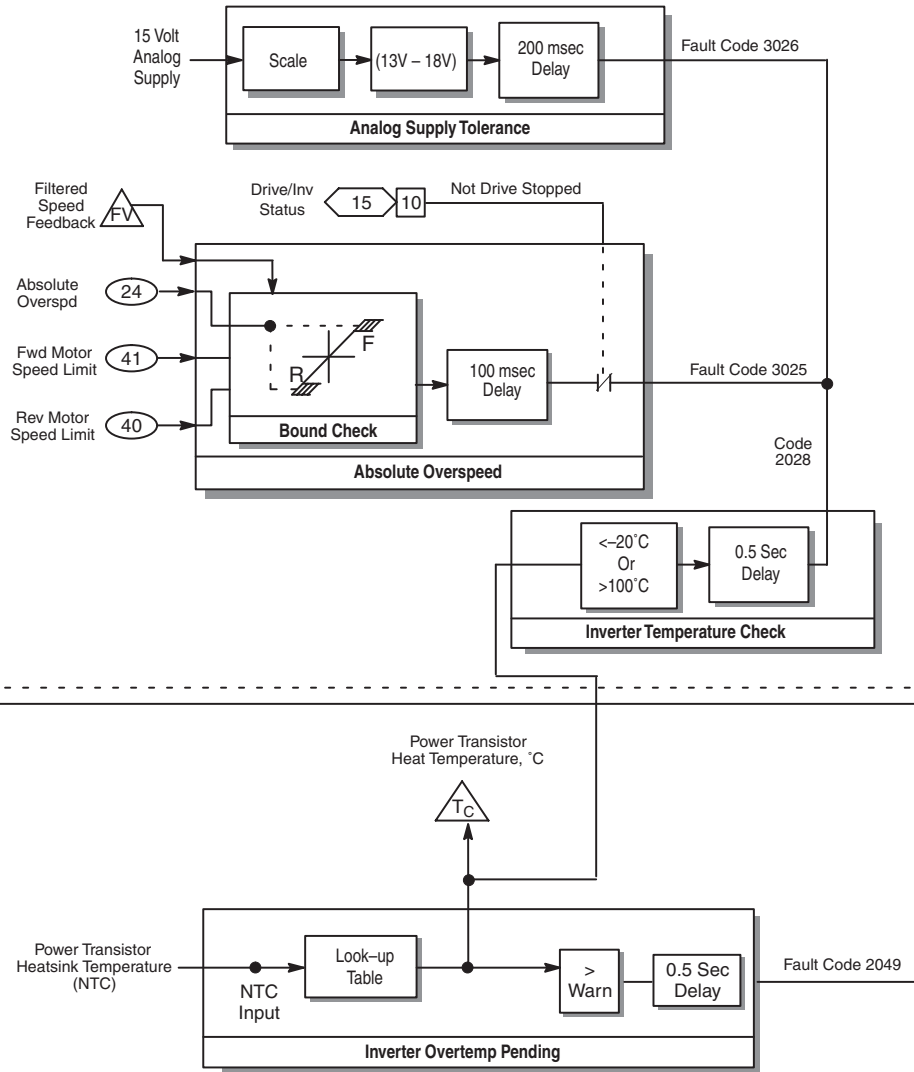
### Drive Fault Detection Overview

You can use the following block diagram to view how the drive detects faults.



Drive Fault Detection Overview, Continued

Non-Configurable Faults



file: Fault Setup  
group: Fault Config

You can configure how you want some situations reported (drive fault, warning, or ignored), while other situations are always reported as faults. For the configurable faults, four parameters are provided: *Fault Select 1* (parameter 20), *Warning Select 1* (parameter 21), *Fault Select 2* (parameter 22), and *Warning Select 2* (parameter 23). For information about these parameters, refer to Chapter 12, *Troubleshooting*.

This section explains how some of the faults are caused and detected.

## The SpdFdbk Loss Fault

*SpdFdbk Loss* is a configurable fault controlled through bit 0 of *Fault Select 2* and *Warning Select 2*. You can only get a *SpdFdbk Loss* fault/warning if you have an encoder on your system, which is indicated when *Fdbk Device Type* (parameter 64) is set to 2. A *SpdFdbk Loss* fault/warning occurs when the hardware detects a loss of encoder input. This can occur for two reasons:

This type of loss:	Occurs when:
Quadrature	There is a loss of quadrature. The most likely cause is a high level of noise on one or both encoder channels.
Phase	The hardware detects that any of four wires (A, A NOT, B, B NOT) is missing.

## The Mtr Stall Fault

*Mtr Stall* is a configurable fault controlled through bit 5 of *Fault Select 2* and *Warning Select 2*. A *Mtr Stall* fault occurs when the motor is not running (zero speed) and the drive is in a limit condition (the drive is putting out maximum torque, current, or power).

<i>file:</i> Monitor
<i>group:</i> Drive/Inv Status

This condition:	Is indicated by:
The motor is not running	Bit 12 in <i>Drive/Inv Status</i> (parameter 15) being set.
The drive is in a limit condition	<i>Torque Limit Sts</i> (parameter 87) having a value other than 0.

<i>file:</i> Fault Setup
<i>group:</i> Fault Limits

You can use *Motor Stall Time* (parameter 25) to enter the length of time that the drive must be in current limit and at zero speed before the drive indicates a *Mtr Stall* fault.

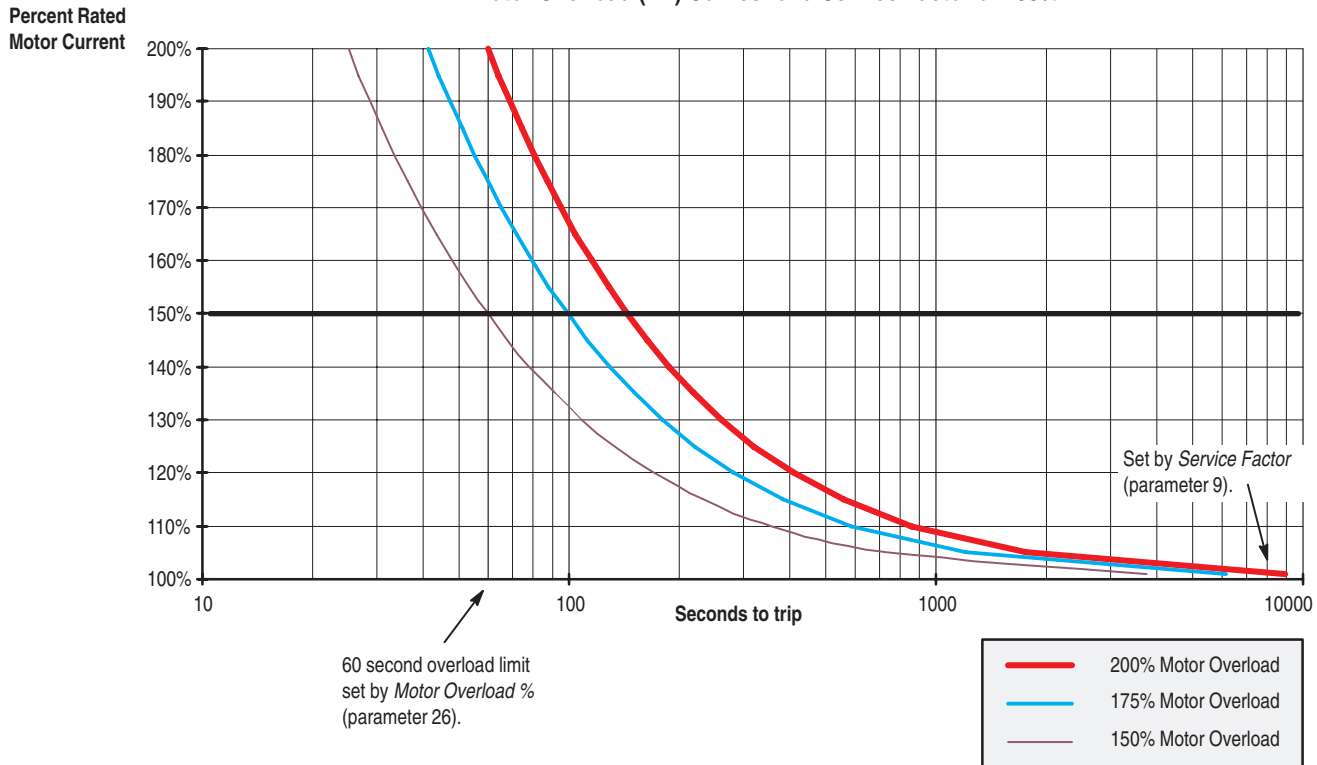
## The MtrOvld Pnd and MtrOvld Trp Faults (I<sup>2</sup>T)

*MtrOvld Pnd* and *MtrOvld Trp* are configurable faults controlled through bits 3 and 4 of *Fault Select 2* and *Warning Select 2*. The faults are generated when points are reached on the motor overload curve. You can use *Service Factor* (parameter 9) and *Motor Overload %* (parameter 26) to change the curve.

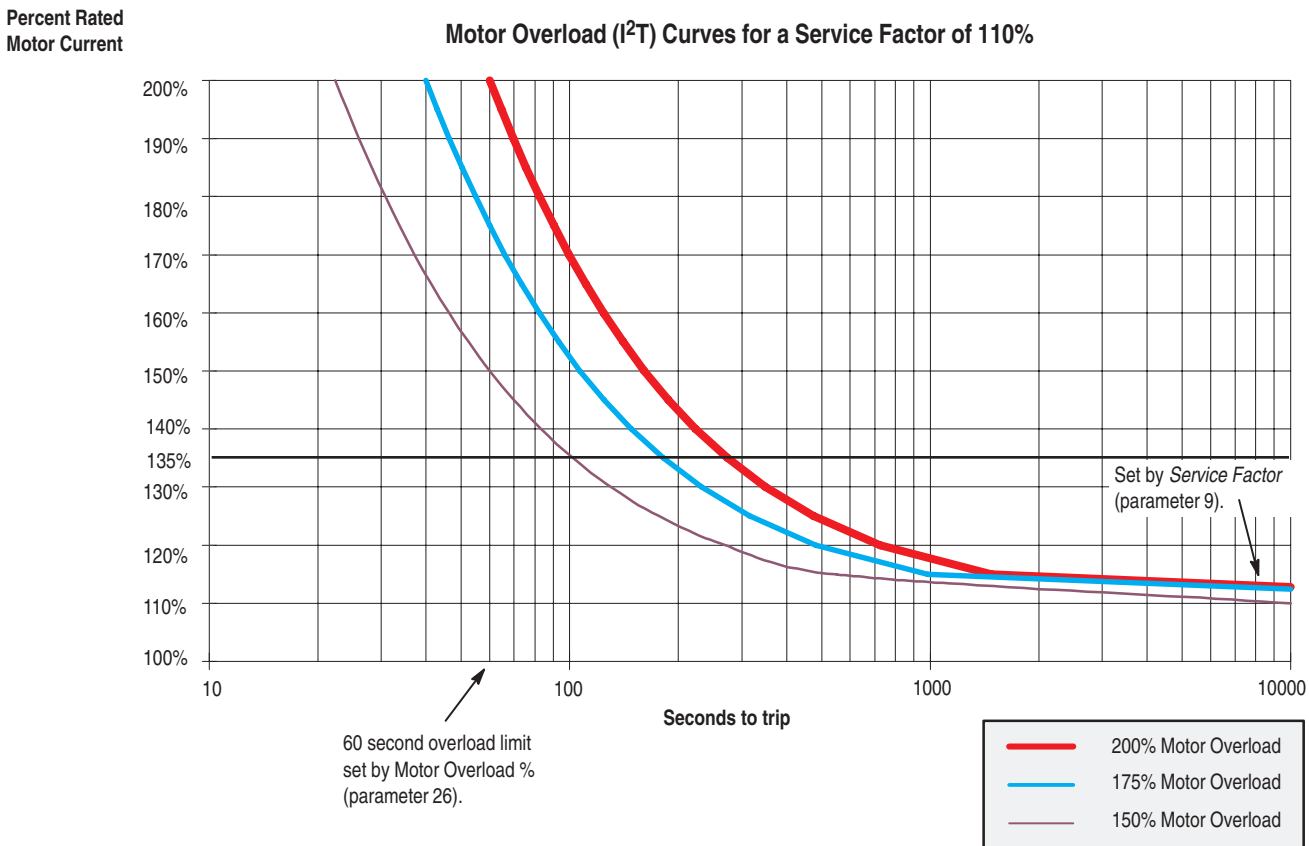


*The following curves do not apply to the H frame. Information for the H frame is not available at the time of printing.*

Motor Overload ( $I^2T$ ) Curves for a Service Factor of 100%



Motor Overload ( $I^2T$ ) Curves for a Service Factor of 110%





### The Analog Spply Tol Fault

*Analog Spply Tol* is a non-configurable fault. It indicates that the voltages from the analog power supply are out of the appropriate range (13V to 18V). If you receive an *Analog Spply Tol* fault, you most likely have a problem with your power supply.

### The Absolute Overspd Fault

*Absolute Overspd* is a non-configurable fault that occurs when the speed feedback regulator indicates that the speed of the motor is greater than the maximum values specified in *Fwd Speed Limit* (parameter 41) and *Rev Speed Limit* (parameter 40). You can use *Absolute Overspd* (parameter 24) to specify how much faster than the maximum speeds specified in *Fwd Speed Limit* and *Rev Speed Limit* the drive can go before generating an *Absolute Overspd* fault.

<i>file:</i> Control
<i>group:</i> Control Limits

### The Inv Overtemp Pnd and Inv Overtemp Trp Faults

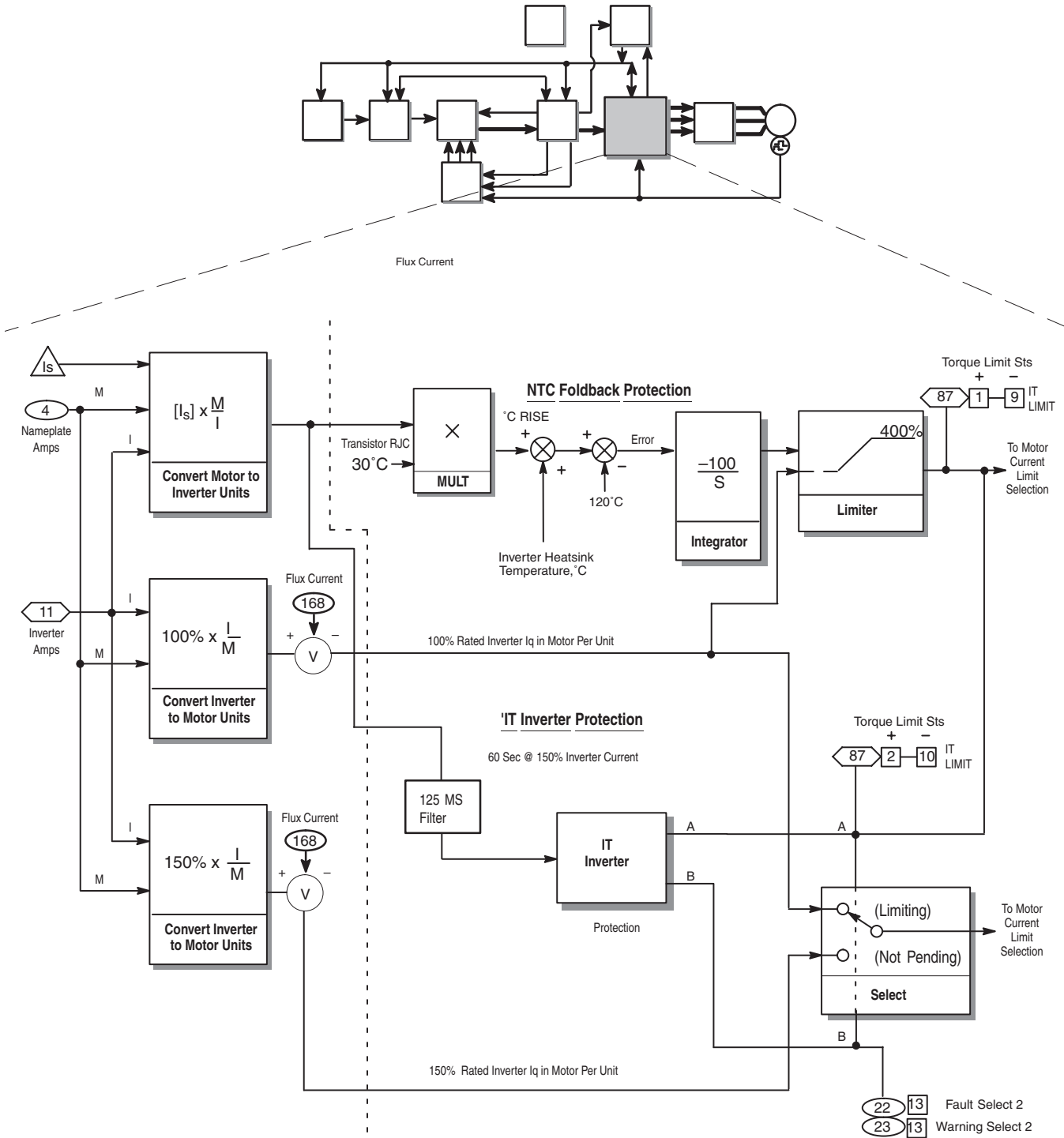
*Inv Overtemp Pnd* is a configurable fault that is controlled through bit 1 of *Fault Select 2* and *Warning Select 2*. The drive monitors the heatsink temperature. If the temperature reaches around 80°C, you will get an *Inv Overtemp Pnd* fault.

*Inv Overtemp Trp* is a non-configurable fault. You will get an *Inv Overtemp Trp* fault if the temperature of the heatsink is not between -20°C and 100°C.

For both faults, the cause may be a sensor either open or shorted, a blocked or inoperative inverter cooling fan, or extended operation of the drive beyond the current rating.

### Inverter Overload Overview

You can use the following block diagram to view how the drive uses the parameters for inverter overload.



The inverter overload is designed to provide limits to ensure that the device ratings for the power semi-conductors are not exceeded. The inverter overload tests for excessive temperatures within the device and excessive current over time (IT).

For both the temperature tests and the current over time tests, the internal reference  $I_s$  is scaled in terms of percent rated motor current. It is also scaled to the inverter. For these conversions, *Nameplate Amps* (parameter 4) and *Inverter Amps* (parameter 11) are also used.

### Understanding the NTC Foldback Protection

The NTC foldback protection test measures for excessive temperatures within the device. To do this:

1. The value of  $I_s$ , which has been converted to inverter units, is multiplied by  $30^\circ\text{C}$ .
2. This value represents a temperature rise that is added to the actual inverter heatsink temperature.
3. From the result of this sum,  $120^\circ\text{C}$  is subtracted.
4. The result is an error value that is integrated and limited.

If NTC foldback predicts that the temperature within the device has exceeded  $120^\circ\text{C}$ , then the motor current is limited (causing a foldback condition).

If the motor current has been limited in the positive direction due to excessive temperature, bit 1 is set in *Torque Limit Sts* (parameter 87). Bit 9 indicates a current limit in the negative direction due to excessive inverter temperature.

*file:* Monitor  
*group:* Drive/Inv Status

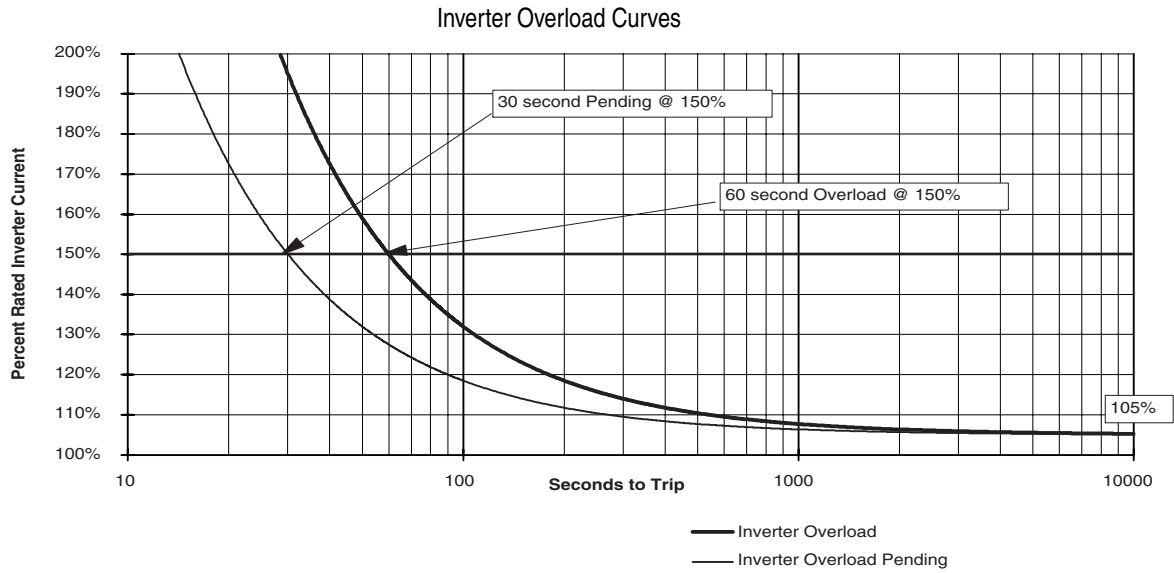
### Understanding the IT Inverter Protection

The IT inverter protection test measures for excessive current over time. To do this for most drives, the test uses both 100% and 150% times the rated inverter current in motor per unit. (For the 460/800 HP H-frame drives, the test uses 100% and 135%.) If the current stays at or above 150% times the rated inverter current for 60 seconds, the test limits the current to 100% times the rated inverter current. When a drive limits the current, either bit 2 (positive values) or bit 10 (negative values) in *Torque Limit Sts* (parameter 87) is set.

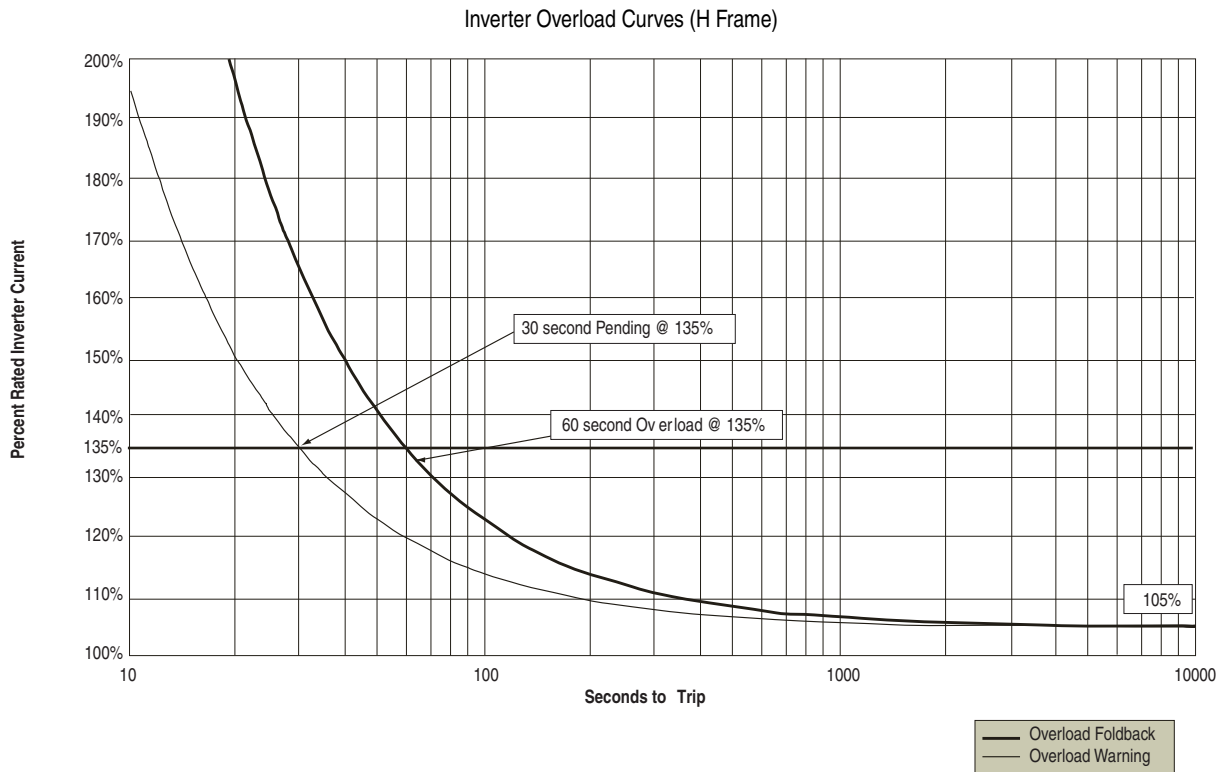
You can also decide if you want to be notified when the drive limits the current.

To:	You need to:
Receive a fault	Set bit 13 in <i>Fault Select 2</i> (parameter 22).
Receive a warning	Set bit 13 in <i>Warning Select 2</i> (parameter 23) and clear bit 13 in <i>Fault Select 2</i> .
Ignore the limit condition	Clear bit 13 in both <i>Fault Select 2</i> and <i>Warning Select 2</i> .

The following is the inverter overload curve for frames A – G This inverter overload curve also applies to the frame H, with the exception of the 460V/800 HP.

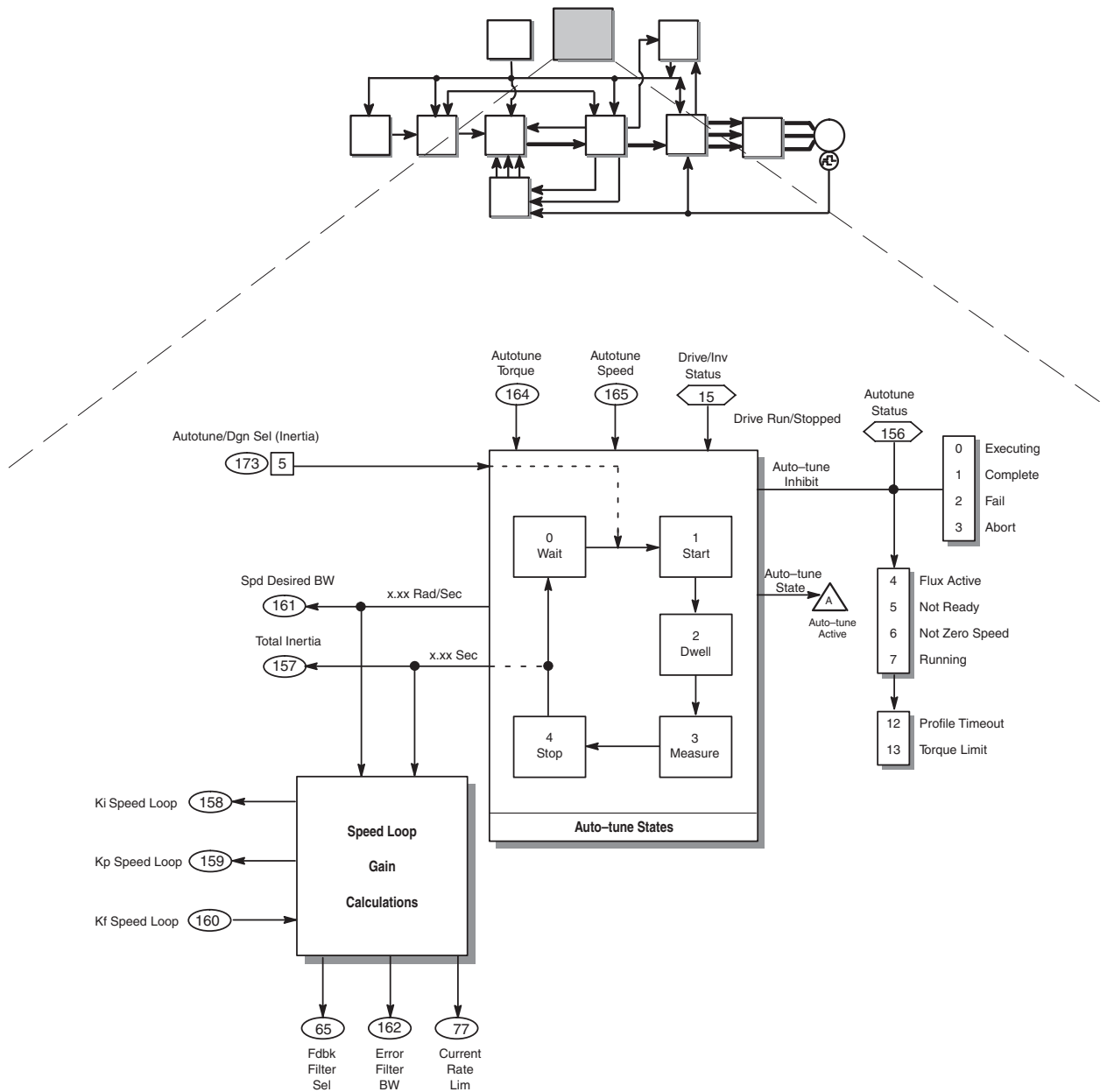


The following is the inverter overload curve for the 460V/800 HP frame H.



# Speed Loop Auto-tune Overview

You can use the following block diagram to view how the drive uses the parameters for speed loop auto-tune.



The speed loop auto-tune test basically measures inertia. To do this, the test cycles through five states:

*file:* Autotune  
*group:* Autotune Setup

In this state:	The test is:
0 (Wait)	Waiting for bit 5 in <i>Autotune/Dgn Sel</i> (parameter 173) to be set. This normally happens when you run auto-tune from the Quick Motor Tune routine.
1 (Start)	Waiting for you to press start.
2 (Dwell)	Waiting for a fixed time period that lets the flux in the motor settle down.
3 (Measure)	Measuring the amount of inertia by applying the amount of torque specified in <i>Autotune Torque</i> (parameter 164) to the motor.
4 (Stop)	Stopping.

## Measuring the Inertia

To measure the inertia, the speed loop auto-tune test:

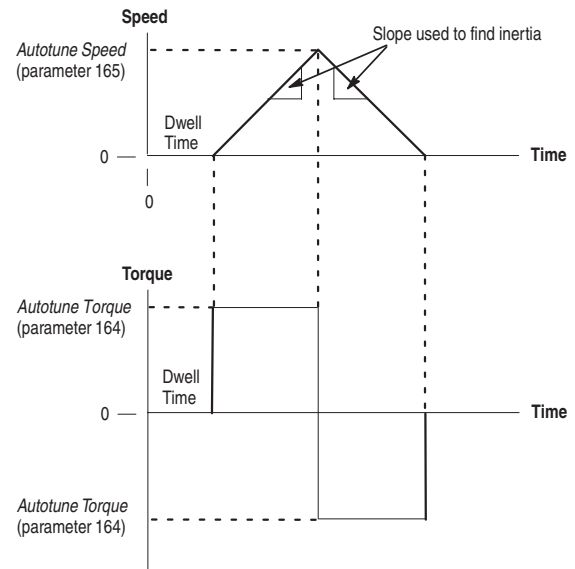
1. Applies the amount of torque specified in *Autotune Torque* (parameter 164) to the motor.
2. Ramps the speed up to the speed specified in *Autotune Speed* (parameter 165).
3. Decreases the speed down to 0.
4. Measures the slope of the increase and decrease to determine the inertia.

*file:* Application  
*group:* Bus Reg/Control

Once the torque is applied, how the test measures the inertia depends on whether bit 10 of *Bus/Brake Opts* (parameter 13) is set.

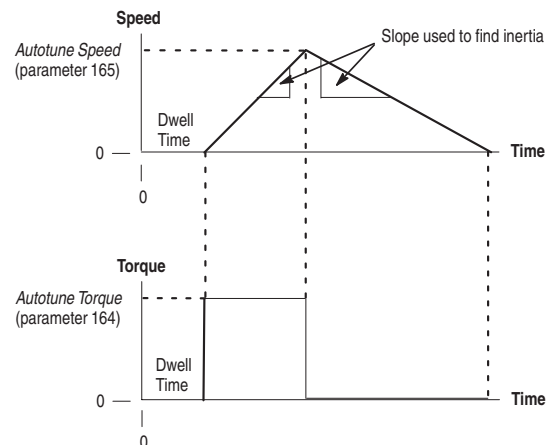
If bit 10 is set, the speed is ramped down to 0 after the motor reaches the speed specified in *Autotune Speed*. At the same time, the torque becomes a negative value and remains negative until the speed reaches 0. This is shown as:

With a brake:



If bit 10 is not set, the speed coasts down to 0 after the motor reaches the speed specified in *Autotune Speed*. The torque also becomes 0 at this point. This is shown as:

With no brake:



*file:* Control  
*group:* Speed Regulator

Once the inertia is determined, the value is placed in *Total Inertia* (parameter 157). The value of *Spd Desired BW* (parameter 161) can then be determined.

Once these values are determined, the speed loop auto-tune test performs the speed loop gain calculations to determine the values of the following parameters:

*file:* Control  
*group:* Speed Regulator  
Speed Feedback  
Control Limits

This parameter:	Has this definition:
<i>Ki Speed Loop</i> (parameter 158)	Controls the integral error gain of the speed regulator.
<i>Kp Speed Loop</i> (parameter 159)	Controls the proportional error gain of the speed regulator.
<i>Kf Speed Loop</i> (parameter 160)	Controls the feed forward gain of the speed regulator.
<i>Fdbk Filter Sel</i> (parameter 65)	Selects the type of feedback filter.
<i>Error Filtr BW</i> (parameter 162)	Sets the bandwidths of two cascaded low pass filters in the Kf error path of the speed PI regulator.
<i>Current Rate Lim</i> (parameter 77)	Specifies the largest allowable rate of change for the current reference signal.

*file:* Autotune  
*group:* Autotune Status

During the speed loop auto-tune, you can check the status of the test by using *Autotune Status* (parameter 156). The first four bits (0 – 3) identify the current status:

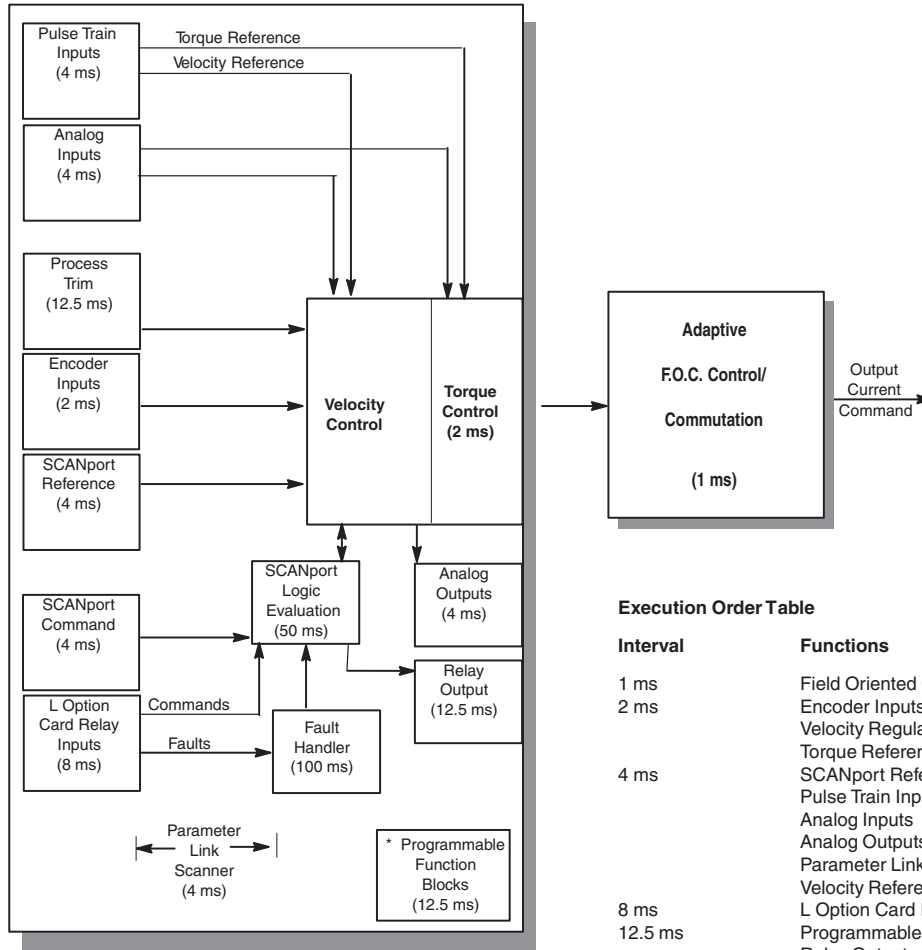
If this bit is set:	Then:
0	The test is currently executing.
1	The test has completed.
2	An error was encountered.
3	The test was aborted because a stop command was issued.

Bits 4 – 7, 12, and 13 identify why bit 2 may have been set.

If this bit is set:	Then:
4	The motor has active flux.
5	The drive is not ready to start auto-tune.
6	The drive is not at zero speed.
7	The motor is running.
12	The auto-tune test timed out because the inertia test failed to accelerate the load. The load must accelerate at a rate of 5% speed change per minute or faster.
13	The inertia test failed to reach the torque limit.

**Through-Put Time**

You can use the following block diagram and table to determine the maximum amount of time that it will take a command to execute.



**Execution Order Table**

Interval	Functions
1 ms	Field Oriented Control
2 ms	Encoder Inputs Velocity Regulator Torque Reference
4 ms	SCANport Reference/Commands Pulse Train Inputs Analog Inputs Analog Outputs Parameter Link Scanner Velocity Reference
8 ms	L Option Card Relay Inputs
12.5 ms	Programmable Function Blocks Relay Outputs Process Trim
50 ms	SCANport Logic Evaluation Drive Logic Start/Stop Sequencing
100 ms	Fault Handler

\* 12.5 ms through put time is in addition to the other scan times of the I/Os.

For example, the time that it takes a speed reference to be converted to an output current can be determined as follows:

SCANport Reference	4 ms
Velocity/Torque Control	2 ms
Adaptive F.O.C. Control/Commutation	1 ms
<b>Total Time</b>	<b>7 ms</b>

The maximum amount of time would thus be 7 ms. (It may take fewer than 7 ms, but will not take more than 7 ms.) Note also that it would take the same amount of time if an analog speed reference were used.



## Using the Human Interface Module (HIM)

### Chapter Objectives

Appendix C provides information so that you can use your Human Interface Module (HIM) more effectively.

This topic:	Starts on page:
What is the Human Interface Module (HIM)	C-1
How does the HIM work	C-3
HIM compatibility information	C-12
Removing the HIM	C-13

### What Is the Human Interface Module (HIM)?

The Human Interface Module (HIM) is the standard user interface for the 1336 IMPACT drive. When the drive mounted HIM is supplied, you can access it from the front of the drive. The HIM provides a way to program the drive and to view the operating parameters. The HIM also lets you control different drive functions.



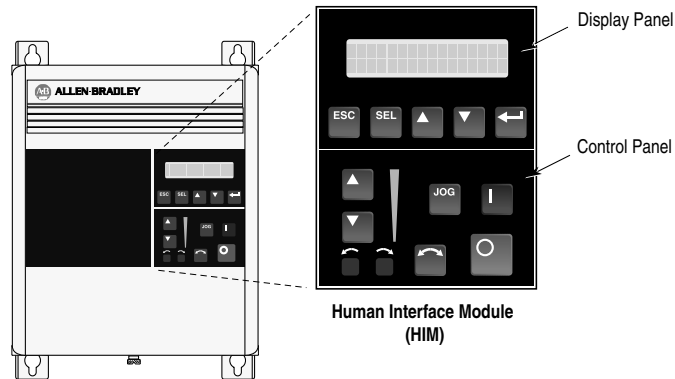
**ATTENTION:** When a drive mounted HIM is not supplied on enclosed NEMA Type 1 (IP20) drives, you must install the blank cover plate (option HAB) to close the opening in the front cover of the enclosure. Failure to install the blank cover plate allows access to electrically live parts that may result in personal injury and/or equipment damage.

When a drive mounted HIM is supplied with enclosed NEMA Type 1 (IP 20) drives, but has been removed from its mounting cradle for remote operation, you must install the blank cover plate in place of the HIM.

The HIM contains a display panel and a control panel. The display panel lets you program the drive and view the various operating parameters. The control panel lets you control different drive functions.

Figure C.1 shows an example of a HIM.

**Figure C.1**  
**Example of a HIM**





The display panel provides the following keys:

Press this key:	To:	This key is referred to as:
	Go back one level in the menu tree that the HIM uses to organize information.	The Escape key
	Alternate which display line (top or bottom) is currently active.	The Select key
	Increment (increase) the selected value. If no value is selected, use this key to scroll through the groups or parameters currently selected.	The Increment key
	Decrement (decrease) the selected value. If no value is selected, use this key to scroll through the groups or parameters currently selected.	The Decrement key
	Select the group or parameter that is currently active or enter the selected parameter value into memory. The top line of the display automatically becomes active to let you choose another parameter or group.	The Enter key

The HIM provides the following keys for the control panel section:

Press this key:	To:	This key is referred to as:
	Start operation if the hardware is enabled and no other control devices are sending a Stop command. You can disable this key by using <i>Start/Jog Mask</i> (parameter 126).	The Start key
	Initiate a stop sequence if the drive is running. The drive stops according to the stop type specified in <i>Logic Options</i> (parameter 17). Clear the fault and reset the drive if the drive has stopped due to a fault.	The Stop key
	Jog the motor at the specified speed. Release the key to stop the jog.	The Jog key
	Change the motor direction. The appropriate Direction Indicator light will light to indicate direction.	The Change Direction key
 	Increase or decrease the HIM speed command. An indication of this command is shown on the visual Speed Indicator. Press both keys simultaneously to store the current HIM speed command in HIM memory. Cycling power or removing the HIM from the drive sets the speed command to the value stored in HIM memory. These arrows are only available with digital speed control.	The Up Arrow and Down Arrow keys

The control panel section also provides the following indicators:

This indicator:	Provides information about:	This is referred to as:
	The direction of motor rotation.	The Direction LED
	An approximate visual indication of the command speed. This indicator is only available with digital speed control.	The Speed Indicator

## HIM Operation

When you first apply power to the 1336 IMPACT drive, the HIM cycles through a series of displays. These displays show the drive name, HIM ID number, and communication status. When complete, the status display shown in Figure C.2 is displayed.

**Figure C.2**  
**Initial Status Display**



The display shows the current status of the drive (such as Stopped or Running) or any faults that may be present.

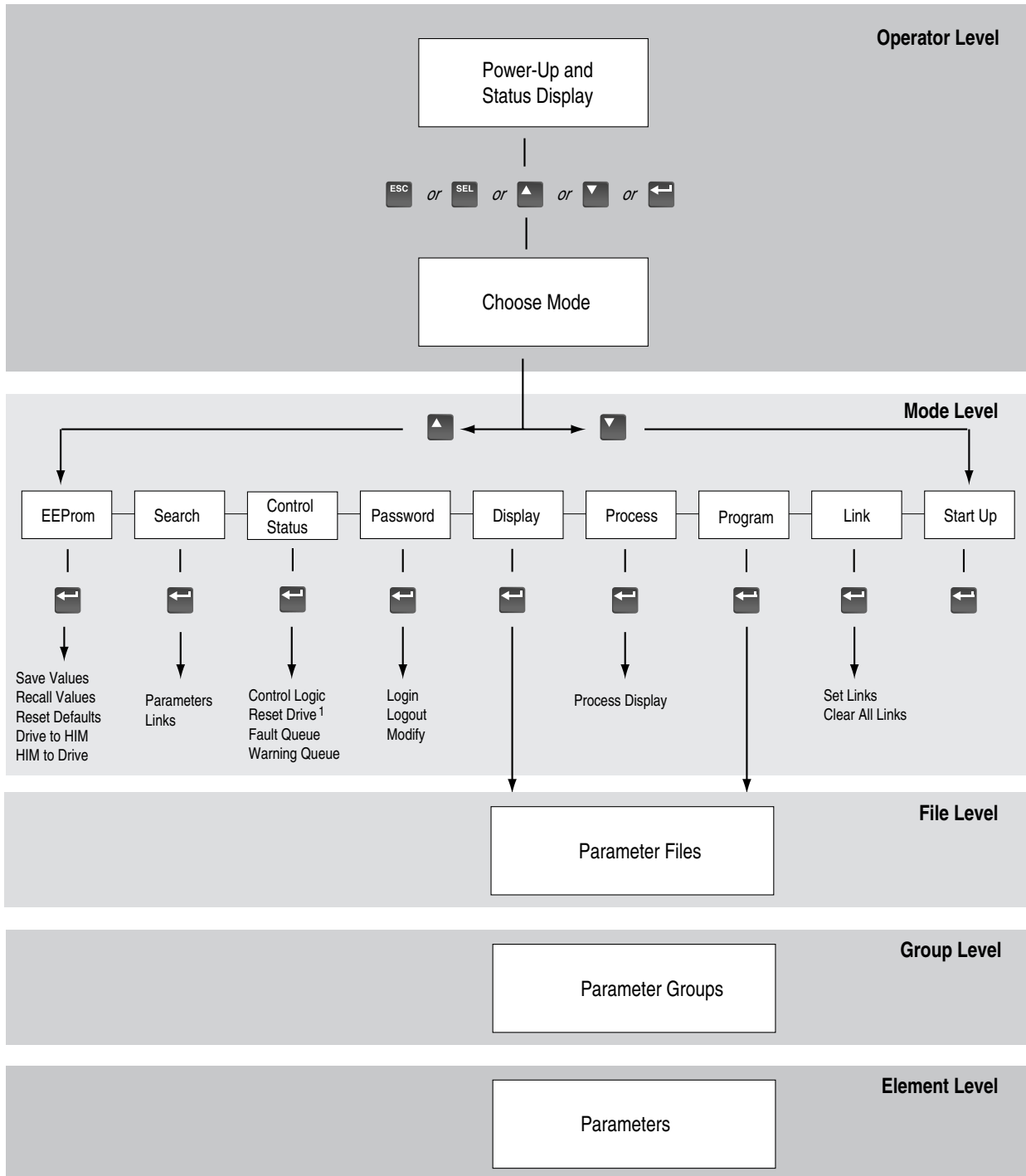
► *On a Series A (Version 3.0) or Series B HIM (see back of HIM for Series information), you can replace the status display with either the Process display or the Password Login menu. This is covered later in this appendix.*

From this display, press any one of the five display panel keys. *Choose Mode* is displayed. Press the *Increment* or *Decrement* key to scroll through the modes.

The following modes are available:

This mode:	Lets you:
Display	View the value of any parameter. You cannot modify any parameters in this mode.
Process	Display two user-selected processes.
Program	Access the complete listing of parameters available for programming.
EEProm	Reset all parameters to the factory default settings. In addition, with a Series B HIM, you can upload/download parameters between the HIM and the drive.
Search	Search for parameters that are not at their default values.
Control Status	Disable or enable the drive logic mask to let you remove the HIM while drive power is applied. <i>SP Enable Mask</i> (parameter 124) lets you disable the logic mask with a Series A HIM below version 3.0. You can also access the fault and warning queues from Control Status. A clear function clears the queue. It will not clear an active fault. Refer to Chapter 12, <i>Troubleshooting</i> , for more information about the fault and warning queues.
Password	Protect the drive parameters against programming changes by unauthorized personnel. When a password has been assigned, you must have the correct password to access the Program/EEProm modes and the Control Logic/Clear Fault Queue menus. You can choose any five digit number between 00000 and 65535 for the password.

**Figure C.3**  
**HIM Menu Tree**



<sup>1</sup> Not available before Version 1.06 Series B.

## Using the Program and Display Modes

The Display and Program modes let you view and program parameters. To use these modes, follow these steps:

1. Press any key from the status display. *Choose Mode* is shown.
2. Press INC or DEC to show *Program* if you want to change the value of a parameter or *Display* if you only want to view the value of a parameter.
3. Press ENTER.
4. Press INC or DEC to scroll through the available files. You may choose among the following files: *Monitor, Control, Fault Setup, Interface/Comm, Motor/Inverter, Application, or Autotune*.
5. Press ENTER.
6. Press INC or DEC to scroll through the available groups. Chapter 11, *Parameters* lists the groups that are available for each file.
7. Press ENTER.
8. Press INC or DEC to scroll through the parameters for the group you chose.

## Viewing and Changing Bit Definitions

Some parameters, such as *Fault Select 1* (parameter 20), have associated bits that you can view, and in some cases, change. If you have a Series A (software version 3.0) or Series B HIM, you can use your HIM to see what each bit means.

For example, if you want your 1336 IMPACT drive to report a fault when a bus undervoltage condition occurs, you need to make sure that bit 3 in *Fault Select 1* is set. To do this, you need to do the following:

1. Navigate through the HIM menu tree structure to the desired parameter. In this example, you want to go to *Fault Select 1* (parameter 20), which is located in the *Fault Setup* file and the *Fault Config* group:



2. Press SEL to view the bit definition for the first bit (bit 0). Bit 0 is located in the lower right. The bits are numbered from 15 to 8 on the top row and 7 to 0 are on the bottom row. An x in any position indicates that the bit is not defined.



3. Press SEL again to view the bit definition of bit 1:



4. Continue pressing SEL until you reach bit 3.

5. To change the value of bit 3 from a 0 to a 1, press either INC or DEC:



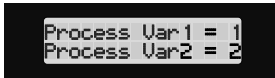
6. Press ENTER to save your changes and exit the bit definitions.

▶ *If the cursor is a blinking underline instead of a flashing character, you are either in Display mode or are trying to change a read-only parameter.*

### Using the Process Mode

Process mode lets you monitor the values of two processes at one time. To use Process mode, you need to:

1. Press any key from the status display. *Choose Mode* is shown.
2. Press INC or DEC to show *Process*.
3. Press ENTER. The following is displayed:



4. Decide which two of the following processes you want to monitor:
 

1 Speed	4 Power
2 Motor current	5 Torque
3 Motor voltage	6 Frequency
5. Press INC or DEC to change the value of process variable 1.
6. Press SEL.
7. Press INC or DEC to change the value of process variable 2.
8. Press ENTER. You should see a display similar to the following:



▶ *If you want the Process Display to appear when drive power is applied, simultaneously press the increment and decrement keys while the Process Display is active.*

To exit Process mode, press the *Escape* key.

## Using the EEPROM Mode

You can use *EEProm* mode to save values, recall values, reset values to the factory defaults, upload a parameter profile from the drive to the HIM, or download a parameter profile. To perform any of these functions, you need to first enter *EEProm* mode by selecting it from the *Choose Mode* prompt.

### Saving Values/Recalling Values

The 1336 IMPACT drive automatically saves the values of the parameters when you make a change. Therefore, you should not need to use these functions in most situations. However, you can use these functions to try to fix problems with the checksum value.

If you have a problem with the checksum, you can:

1. Select *Recall Values*.
2. Select *Save Values*.
3. Check the values of the parameters.

### Resetting the Default Values

To reset the values of all parameters to the factory default values:

1. From the EEPROM mode prompt, press INC or DEC until *Reset Defaults* is displayed.
2. Press ENTER to restore all parameters to their original factory setting.
3. Press *Escape*. *Reprogram Fault* is displayed.
4. Press the *Stop* key to reset the fault. If *Input Mode* was previously set to a value other than 1, cycle drive power to reset.

### Uploading a Parameter Profile

To upload a parameter profile from the drive to the HIM, you must have a Series B HIM.

1. From the EEPROM mode prompt, press INC or DEC until *Drive > HIM* is displayed.
2. Press ENTER. A profile name (up to 14 characters) is displayed on line 2 of the HIM.
3. Change this name or enter a new name. Use SEL to move the cursor to the left. Use INC or DEC to change the characters.
4. Press ENTER. An informational display is shown. This display indicates the drive type and firmware version.
5. Press ENTER to start the upload. The parameter number currently being uploaded is displayed on line 1 of the HIM. Line 2 indicates the total progress. Press ESC to stop the upload.
6. Press ENTER when *COMPLETE* is displayed on line 2. If line 2 reports *ERROR*, refer to the *Troubleshooting* section.

### Downloading a Parameter Profile

To download a parameter profile from the HIM to a drive, you must have a Series B HIM.

**Important:** The download function is only available when a valid profile is stored in the HIM.

1. From the EEPROM mode prompt, press INC or DEC until *HIM* → *Drive* is displayed.
2. Press ENTER. A profile name (up to 14 characters) is displayed on line 2 of the HIM.
3. Press INC or DEC to scroll to a second profile (if available).
4. Press ENTER when the desired profile name is displayed. An information display is shown that indicates the version numbers of the profile and the drive.
5. Press ENTER to start the download. The parameter number currently being downloaded is displayed on line 1 of the HIM. Line 2 indicates the total progress. Press *ESC* to stop the download.
6. Press ENTER when *COMPLETE* is displayed on line 2. If line 2 reports *ERROR*, refer to the following table.

If you receive this error:	Then:
Error 1	An EEPROM CRC error occurred.
Error 2	The profile is a different length than the master.
Error 3	You are downloading between different types of masters.
Error 4	The data is out of range or illegal.
Error 5	You attempted the download while the drive was running.
Error 6	You are downloading between different types of masters.

### Using the Search Mode

Search mode lets you search through the parameter list and display all parameters that are not at the factory default values. You can also search for links that are not the factory defaults.

► *Search mode is only available with a Series A (version 3.0) or Series B HIM.*

To use Search mode:

1. From the status display, press any key. *Choose Mode* is shown.
2. Press INC or DEC to show *Search*.
3. Press ENTER.
4. To search through the parameter list, press INC or DEC or until *Parameters* is displayed. To search through the links, press INC or DEC until *Links* is displayed.
5. Press ENTER. The HIM searches through all parameters and displays any parameters/links that are not at their factory defaults.
6. Press INC or DEC to scroll through the list.



## Using the Control Status Mode

Control Status mode lets you enable/disable the drive logic and check the fault and warning queues.

- *Control Status mode is only available with a Series A (version 3.0) or Series B HIM.*

## Using Control Logic

The Control Logic option lets you disable the drive logic mask to prevent a serial fault when the HIM is removed with the drive power applied.

To use Control Logic:

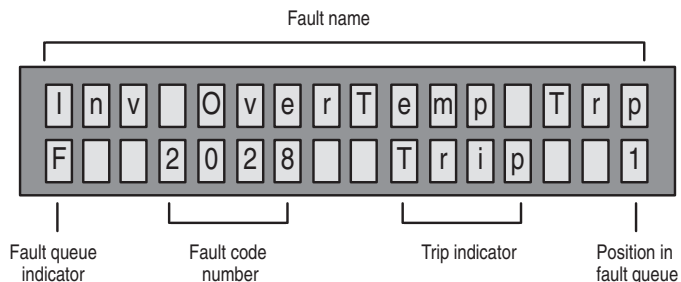
1. From the status display, press any key. *Choose Mode* is shown.
2. Press INC or DEC to show *Control Status*.
3. Press ENTER.
4. Press INC or DEC until *Control Logic* is displayed.
5. Press ENTER.
6. Press SEL.
7. Press INC or DEC to select either *Disabled* (or *Enabled*).
8. Press ENTER. The logic mask is now disabled (or enabled).

## Viewing the Fault Queue/Warning Queue

To view either the fault or the warning queue:

1. Press any key from the status display. *Choose Mode* is shown.
2. Press INC or DEC to show *Control Status*.
3. Press ENTER.
4. Press INC or DEC until *Fault Queue* or *Warning Queue* is displayed.
5. Press ENTER.
6. Press INC or DEC until *View Queue* is displayed.
7. Press ENTER.

The fault queue can contain up to 32 faults. The 1336 IMPACT drive reports the faults using the following format:



The trip indicator is only present if this fault caused the drive to trip. The last number (1) indicates this fault's position within the fault queue.

A marker is placed in the queue when the first fault occurs after a power up sequence. This power up marker is as shown.



The 1336 IMPACT drive keeps track of the time that has elapsed since power up. The drive uses this information as a time stamp so that you can tell when a fault occurred in relation to when the drive was powered up. To view the time stamp, you need to use *Test Data 2* (parameter 94) and *Test Select 2* (parameter 95). You need to enter one value into *Test Select 2* to view the time in hours since power up and another value to view the minutes and seconds. These values are listed in the *Test Select 2* description in Chapter 11, *Parameters*

As an example, if you want to know when the fault in position 12 occurred in relation to when the drive was powered up, you would need to do the following:

1. Enter a value of 11112 in *Test Select 2* (parameter 95).
2. Look at the value of *Test Data 2* (parameter 94). This value represents the number of hours after power up that the fault in position 12 occurred.
3. Enter a value of 11212 in *Test Select 2*.
4. Look at the value of *Test Data 2* to see the number of minutes and seconds after power up that the fault in position 12 occurred.

To clear the fault queue, select *Clear Queue* from the *Fault Queue* options.

To view the warning queue, select *Warning Queue* from the *Control Status* options. The remaining steps are the same as for the fault queue.

### Using the Password Mode

Password mode lets you enable password protection and change the password. By default, the password is 0, which disables password protection.

To use Password mode:

1. Press any key from the status display. *Choose Mode* is shown.
2. Press INC or DEC to show *Password*.
3. Press ENTER.
4. Press INC or DEC until *Modify* is displayed.
5. Press ENTER. *Enter Password* is displayed.
6. Press INC or DEC to scroll to your desired new password. With a Series A (Version 3.0) or Series B HIM, SEL moves the cursor.
7. Press ENTER to save your password.
8. Press ENTER again to return to Password mode.
9. Press INC or DEC until *Logout* is displayed.
10. Press ENTER to log out of Password mode.

With a Series A (Version 3.0) or Series B HIM, you can program Password mode to be displayed when drive power is applied. To do this, you need to press the *Increment* and *Decrement* keys simultaneously while the Password display is shown.

Once you set the password, the Program/EEProm modes and the Control Logic/Clear Queue menus are password protected and are not displayed in the menu. To access these modes, you need to:

1. Press any key from the status display. *Choose Mode* is shown.
2. Press INC or DEC to show *Password*.
3. Press ENTER.
4. Press ENTER. *Enter Password* is displayed.
5. Press INC or DEC until your correct password is displayed. With a Series A (Version 3.0) or Series B HIM, SEL moves the cursor.
6. Press ENTER.

You can now access the Program and EEPROM modes. To prevent future access to program changes, you need to logout:

1. Press any key from the status display. *Choose Mode* is shown.
2. Press INC or DEC to show *Password*.
3. Press ENTER.
4. Press INC or DEC until *Logout* is displayed.
5. Press ENTER to log out of Password mode.

### Creating a Link

You create links at the destination parameter. To create a link:

1. Go to the parameter that you want to receive the information.
2. Enter the number of the source parameter.

The following example uses a Human Interface Module (HIM) to create a link. For this example, *SP An Output* (parameter 139) is the destination parameter that is linked to *Motor Torque %* (parameter 86), which is the source parameter. To create this link:

1. From the *Choose Mode* prompt, use INC or DEC to select *Links*.
2. Press INC or DEC to select *Set Links*. The HIM automatically scrolls through the linear parameter list until it finds a parameter that you can link.
3. Use INC or DEC to scroll through the parameter list until you come to the destination parameter that you want to link. In this example, you would use INC or DEC until you reach parameter 139. The display should be similar to the following:



SP An Output  
<139><---

4. Press SEL. The display should now be similar to the following:



ot Linked  
139 <--- < 0>

5. Press INC or DEC to go to the parameter that you want to provide the information. In this case, parameter 86 — *Motor Torque %*.
6. Press ENTER.
7. Press ESC when you have finished to exit the *Set Links* mode.

### Removing a Link

To remove a link, you need to:



**ATTENTION:** Be careful when removing links. If the source parameter has already written a value to the destination parameter, the destination parameter retains the value until you explicitly remove it. For some parameters, this may produce undesirable results.

1. From the *Choose Mode* prompt, use INC or DEC to select *Links*.
2. Press INC or DEC to select *Set Links*.
3. Use INC or DEC to scroll through the parameter list until you come to the destination parameter that you want to link.
4. Press SEL.
5. Enter 0.
6. Press ENTER.
7. Press ESC when you have finished to exit the *Set Links* mode.

### HIM Compatibility Information

If your HIM was shipped with your 1336 IMPACT drive, it should be fully compatible with your drive. However, if you are using a HIM that you purchased before purchasing your IMPACT drive, you should read this section and understand which features your HIM supports and which are not supported.

If your HIM is older than:	Then your HIM does not support:
Version 1.07 Series B	<ul style="list-style-type: none"> <li>• The ability for the HIM to remove one decimal point from parameters with values too large to display.</li> </ul>
Version 1.06 Series B	<ul style="list-style-type: none"> <li>• Version 1.07 Series B enhancement.</li> <li>• The reset function.</li> <li>• The ability to change the process display.</li> <li>• Enhanced parameter value changing.</li> <li>• A number accelerator. As you hold a button down longer to change a value/parameter, the number will increase incrementally faster.</li> </ul>
Version 1.04 Series B	<ul style="list-style-type: none"> <li>• Version 1.06 Series B enhancements.</li> <li>• The ability to download information to a different size drive.</li> </ul>
Version 1.01 Series B	<ul style="list-style-type: none"> <li>• Version 1.04 Series B enhancement.</li> <li>• The copy cat function.</li> <li>• The ability to escape out of the Search and Link functions.</li> <li>• The display of the trip fault for the fault display.</li> <li>• Support for the start up procedure.</li> </ul>

If your HIM is older than:	Then your HIM does not support:
Version 3.00 Series A	<ul style="list-style-type: none"> <li>• Version 1.04 and 1.01 Series B enhancements.</li> <li>• The ability to display enums.</li> <li>• The ability to change any digit of parameter values.</li> <li>• The first fault displayed anywhere in the menu structure.</li> <li>• The ability to change any digit of a password value by using the <i>Select</i> key.</li> <li>• The choice of process variables if more than one process is available.</li> <li>• The ability to clear all links.</li> <li>• Additional parameter text for links.</li> <li>• The Search menu structure.</li> <li>• The Control Status menu structure.</li> <li>• The ability to enable/disable the logic mask.</li> <li>• The menu for the fault queue.</li> <li>• The menu for the warning queue.</li> <li>• The file/group structure.</li> </ul>

To determine what version of the HIM you have, turn your module over (remove it from the drive first, if necessary). The version is located on the back of the HIM.

## Removing the HIM

For handheld operation, you can remove the module and place it up to 10 meters (33 feet) from the 1336 IMPACT drive.



**ATTENTION:** Some voltages present behind the drive front cover are at incoming line potential. To avoid an electric shock hazard, use extreme caution when removing/replacing the HIM.

**Important:** Removing a HIM (or other SCANport device) from a drive while power is applied causes a Serial Fault, unless *SP Enable Mask* (parameter 124) or *Fault Select 1* (parameter 20) have been set to disable this fault or *Control Logic* (from the *Control Status* menu) has been disabled (only available on a Series A, version 3.0 or Series B HIM). Setting bit 1 of *SP Enable Mask* to 0 disables Serial Fault from a HIM on port 1. It also disables all HIM control functions except Stop. Setting bit 9 of *Fault Select 1* to 0 disables the serial fault from the HIM on port 1 but still allows HIM control.



**ATTENTION:** Hazard of personal injury or equipment damage exist. If you initiate a command to start motor rotation (command a start or jog) and then disconnect the programming device, the drive will not fault if you have the SCANport communications fault set to be ignored for that port.

To remove the HIM, you need to:

1. Either remove the power or clear the port bit, which corresponds to the port the HIM is attached to, in *SP Enable Mask* (parameter 124) or *Fault Select 1* (parameter 20) to prevent the drive from faulting.
2. Remove the front cover of the drive.
3. Slide the module down out of its cradle.

To use the module from anywhere up to 10 meters (33 feet) from your drive, you need to:

1. Connect the appropriate cable between the HIM and the communications port (adapter 2, 3, 4, or 5) or adapter 1 (the HIM cradle).
2. Set *SP Enable Mask* to enable the port that you plugged the HIM into and/or *Fault Select 1* (parameter 20).

To replace the module, follow these steps:

1. Slide the module up into its cradle.
2. Replace the front cover of the drive.
3. Apply power, set *SP Enable Mask* or set *Fault Select 1*.

## Derating Guidelines

### Chapter Objectives

A number of factors can affect drive ratings. Appendix D contains the derating guidelines for the 1336 IMPACT drive. If your drive is affected by more than one factor, contact Rockwell Automation.

<b>This catalog number:</b>	<b>Is shown in:</b>
1336E-AQF05 – 50	Figure D.1
1336E-A010	Figure D.2
1336E-A015	Figure D.3
1336E-A020	Figure D.4
1336E-A025	Figure D.5
1336E-A040	Figure D.6
1336E-A050	Figure D.7
1336E-A060	Figure D.8
1336E-A075	Figure D.9
1336E-A100	Figure D.10
1336E-BRF05 – 100	Figure D.1
1336E-B015	Figure D.11
1336E-B020	Figure D.2
1336E-B025	Figure D.12
1336E-B030	Figure D.3
1336E-B040	Figure D.4
1336E-BX040	Figure D.13
1336E-B050	Figure D.5
1336E-BX060	Figure D.5
1336E-B075	Figure D.14
1336E-B100	Figure D.15
1336E-B125	Figure D.16
1336E-B150	Figure D.9
1336E-BX150	Figure D.16
1336E-B200	Figure D.10
1336E-B250	Figure D.17
1336E-BP300	Figure D.18
1336E-BP350	Figure D.19
1336E-BP400	Figure D.20
1336E-BP450	Figure D.21
1336E-B500	Figure D.22
1336E-B600	Figure D.23
1336E-B700C	Figure D.24
1336E-B800C	Figure D.24
1336E-C075	Figure D.25
1336E-C100	Figure D.26
1336E-C125	Figure D.27
1336E-C150	Figure D.28
1336E-C200	Figure D.29
1336E-C250	Figure D.30
1336E-CP350	Figure D.38
1336E-C400	Figure D.31
1336E-CP400	Figure D.39
1336E-C450	Figure D.32
1336E-C500	Figure D.37
1336E-C600	Figure D.38
1336E-C650	Figure D.39
1336E-C700C	Figure D.39
1336E-C800C	Figure D.39

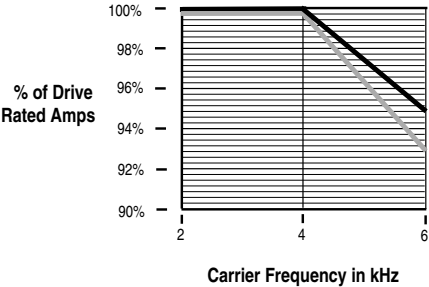
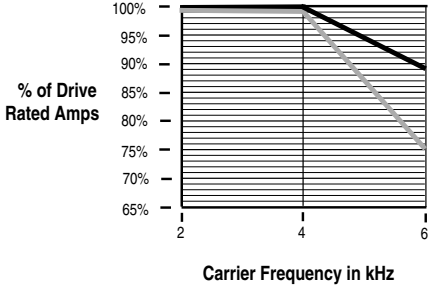
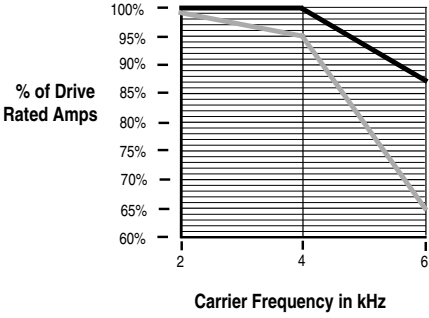
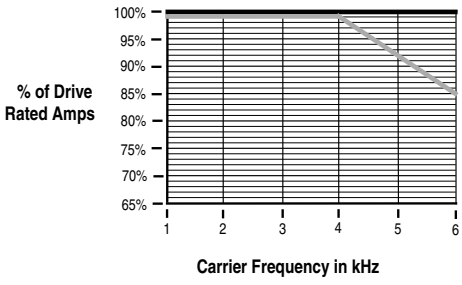
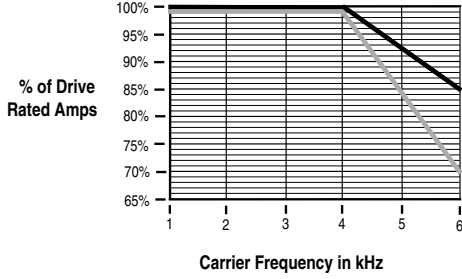
# Derating Guidelines

Standard rating for enclosed drive in 40°C ambient and open drive in 50°C ambient.  
 Derating factor for enclosed drive in ambient between 41°C and 50°C.

Figure/Catalog Number	Derate																																										
<b>Figure D.1</b> <b>AQ05-50 and</b> <b>BRF05-100</b>	<table border="1"> <caption>Data for Figure D.1</caption> <thead> <tr> <th>Carrier Frequency (kHz)</th> <th>Standard Rating (%)</th> <th>Derating Factor (%)</th> </tr> </thead> <tbody> <tr><td>0</td><td>100</td><td>100</td></tr> <tr><td>1</td><td>100</td><td>98.5</td></tr> <tr><td>2</td><td>100</td><td>97</td></tr> <tr><td>3</td><td>100</td><td>95.5</td></tr> <tr><td>4</td><td>100</td><td>94</td></tr> <tr><td>5</td><td>100</td><td>92.5</td></tr> <tr><td>6</td><td>100</td><td>91</td></tr> <tr><td>7</td><td>100</td><td>89.5</td></tr> <tr><td>8</td><td>100</td><td>88</td></tr> <tr><td>9</td><td>98.5</td><td>86.5</td></tr> <tr><td>10</td><td>97</td><td>85</td></tr> <tr><td>11</td><td>95.5</td><td>83.5</td></tr> <tr><td>12</td><td>93</td><td>82</td></tr> </tbody> </table>	Carrier Frequency (kHz)	Standard Rating (%)	Derating Factor (%)	0	100	100	1	100	98.5	2	100	97	3	100	95.5	4	100	94	5	100	92.5	6	100	91	7	100	89.5	8	100	88	9	98.5	86.5	10	97	85	11	95.5	83.5	12	93	82
Carrier Frequency (kHz)	Standard Rating (%)	Derating Factor (%)																																									
0	100	100																																									
1	100	98.5																																									
2	100	97																																									
3	100	95.5																																									
4	100	94																																									
5	100	92.5																																									
6	100	91																																									
7	100	89.5																																									
8	100	88																																									
9	98.5	86.5																																									
10	97	85																																									
11	95.5	83.5																																									
12	93	82																																									
<b>Figure D.2</b> <b>A010 and B020</b>	<table border="1"> <caption>Data for Figure D.2</caption> <thead> <tr> <th>Carrier Frequency (kHz)</th> <th>Standard Rating (%)</th> <th>Derating Factor (%)</th> </tr> </thead> <tbody> <tr><td>0</td><td>100</td><td>100</td></tr> <tr><td>1</td><td>100</td><td>98</td></tr> <tr><td>2</td><td>100</td><td>96</td></tr> <tr><td>3</td><td>100</td><td>94</td></tr> <tr><td>4</td><td>100</td><td>92</td></tr> <tr><td>5</td><td>100</td><td>90</td></tr> <tr><td>6</td><td>100</td><td>88</td></tr> <tr><td>7</td><td>100</td><td>86</td></tr> <tr><td>8</td><td>100</td><td>84</td></tr> <tr><td>9</td><td>98</td><td>82</td></tr> <tr><td>10</td><td>96</td><td>80</td></tr> <tr><td>11</td><td>94</td><td>78</td></tr> <tr><td>12</td><td>92</td><td>76</td></tr> </tbody> </table>	Carrier Frequency (kHz)	Standard Rating (%)	Derating Factor (%)	0	100	100	1	100	98	2	100	96	3	100	94	4	100	92	5	100	90	6	100	88	7	100	86	8	100	84	9	98	82	10	96	80	11	94	78	12	92	76
Carrier Frequency (kHz)	Standard Rating (%)	Derating Factor (%)																																									
0	100	100																																									
1	100	98																																									
2	100	96																																									
3	100	94																																									
4	100	92																																									
5	100	90																																									
6	100	88																																									
7	100	86																																									
8	100	84																																									
9	98	82																																									
10	96	80																																									
11	94	78																																									
12	92	76																																									
<b>Figure D.3</b> <b>A015 and B030</b>	<table border="1"> <caption>Data for Figure D.3</caption> <thead> <tr> <th>Carrier Frequency (kHz)</th> <th>Standard Rating (%)</th> <th>Derating Factor (%)</th> </tr> </thead> <tbody> <tr><td>0</td><td>100</td><td>100</td></tr> <tr><td>1</td><td>100</td><td>98</td></tr> <tr><td>2</td><td>100</td><td>96</td></tr> <tr><td>3</td><td>100</td><td>94</td></tr> <tr><td>4</td><td>100</td><td>92</td></tr> <tr><td>5</td><td>100</td><td>90</td></tr> <tr><td>6</td><td>100</td><td>88</td></tr> <tr><td>7</td><td>100</td><td>86</td></tr> <tr><td>8</td><td>100</td><td>84</td></tr> <tr><td>9</td><td>98</td><td>82</td></tr> <tr><td>10</td><td>96</td><td>80</td></tr> <tr><td>11</td><td>94</td><td>78</td></tr> <tr><td>12</td><td>92</td><td>76</td></tr> </tbody> </table>	Carrier Frequency (kHz)	Standard Rating (%)	Derating Factor (%)	0	100	100	1	100	98	2	100	96	3	100	94	4	100	92	5	100	90	6	100	88	7	100	86	8	100	84	9	98	82	10	96	80	11	94	78	12	92	76
Carrier Frequency (kHz)	Standard Rating (%)	Derating Factor (%)																																									
0	100	100																																									
1	100	98																																									
2	100	96																																									
3	100	94																																									
4	100	92																																									
5	100	90																																									
6	100	88																																									
7	100	86																																									
8	100	84																																									
9	98	82																																									
10	96	80																																									
11	94	78																																									
12	92	76																																									
<b>Figure D.4</b> <b>A020 and B040</b>	<table border="1"> <caption>Data for Figure D.4</caption> <thead> <tr> <th>Carrier Frequency (kHz)</th> <th>Standard Rating (%)</th> <th>Derating Factor (%)</th> </tr> </thead> <tbody> <tr><td>0</td><td>100</td><td>100</td></tr> <tr><td>1</td><td>100</td><td>98</td></tr> <tr><td>2</td><td>100</td><td>96</td></tr> <tr><td>3</td><td>100</td><td>94</td></tr> <tr><td>4</td><td>100</td><td>92</td></tr> <tr><td>5</td><td>100</td><td>90</td></tr> <tr><td>6</td><td>100</td><td>88</td></tr> <tr><td>7</td><td>100</td><td>86</td></tr> <tr><td>8</td><td>100</td><td>84</td></tr> <tr><td>9</td><td>98</td><td>82</td></tr> <tr><td>10</td><td>96</td><td>80</td></tr> <tr><td>11</td><td>94</td><td>78</td></tr> <tr><td>12</td><td>92</td><td>76</td></tr> </tbody> </table>	Carrier Frequency (kHz)	Standard Rating (%)	Derating Factor (%)	0	100	100	1	100	98	2	100	96	3	100	94	4	100	92	5	100	90	6	100	88	7	100	86	8	100	84	9	98	82	10	96	80	11	94	78	12	92	76
Carrier Frequency (kHz)	Standard Rating (%)	Derating Factor (%)																																									
0	100	100																																									
1	100	98																																									
2	100	96																																									
3	100	94																																									
4	100	92																																									
5	100	90																																									
6	100	88																																									
7	100	86																																									
8	100	84																																									
9	98	82																																									
10	96	80																																									
11	94	78																																									
12	92	76																																									
<b>Figure D.5</b> <b>A025, B050, and</b> <b>BX060</b>	<table border="1"> <caption>Data for Figure D.5</caption> <thead> <tr> <th>Carrier Frequency (kHz)</th> <th>Standard Rating (%)</th> <th>Derating Factor (%)</th> </tr> </thead> <tbody> <tr><td>0</td><td>100</td><td>100</td></tr> <tr><td>1</td><td>100</td><td>98</td></tr> <tr><td>2</td><td>100</td><td>96</td></tr> <tr><td>3</td><td>100</td><td>94</td></tr> <tr><td>4</td><td>100</td><td>92</td></tr> <tr><td>5</td><td>98</td><td>90</td></tr> <tr><td>6</td><td>96</td><td>88</td></tr> <tr><td>7</td><td>94</td><td>86</td></tr> <tr><td>8</td><td>92</td><td>84</td></tr> <tr><td>9</td><td>90</td><td>82</td></tr> <tr><td>10</td><td>88</td><td>80</td></tr> <tr><td>11</td><td>86</td><td>78</td></tr> <tr><td>12</td><td>84</td><td>76</td></tr> </tbody> </table>	Carrier Frequency (kHz)	Standard Rating (%)	Derating Factor (%)	0	100	100	1	100	98	2	100	96	3	100	94	4	100	92	5	98	90	6	96	88	7	94	86	8	92	84	9	90	82	10	88	80	11	86	78	12	84	76
Carrier Frequency (kHz)	Standard Rating (%)	Derating Factor (%)																																									
0	100	100																																									
1	100	98																																									
2	100	96																																									
3	100	94																																									
4	100	92																																									
5	98	90																																									
6	96	88																																									
7	94	86																																									
8	92	84																																									
9	90	82																																									
10	88	80																																									
11	86	78																																									
12	84	76																																									



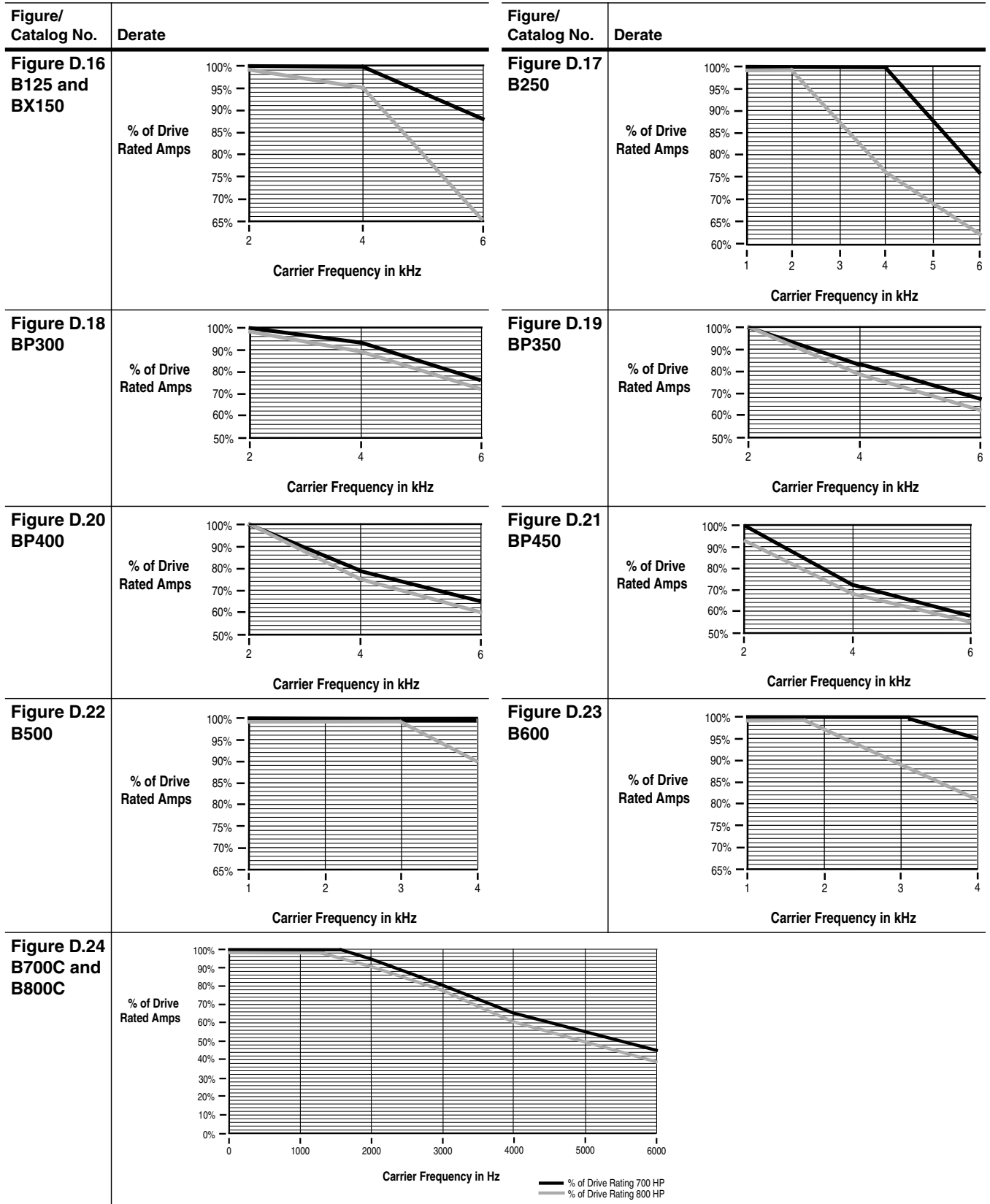
Standard rating for enclosed drive in 40°C ambient and open drive in 50°C ambient.  
 Derating factor for enclosed drive in ambient between 41°C and 50°C.

Figure/Catalog Number	Derate
<b>Figure D.6</b> <b>A040</b>	
<b>Figure D.7</b> <b>A050</b>	
<b>Figure D.8</b> <b>A060</b>	
<b>Figure D.9</b> <b>A075 and B150</b>	
<b>Figure D.10</b> <b>A100 and B200</b>	

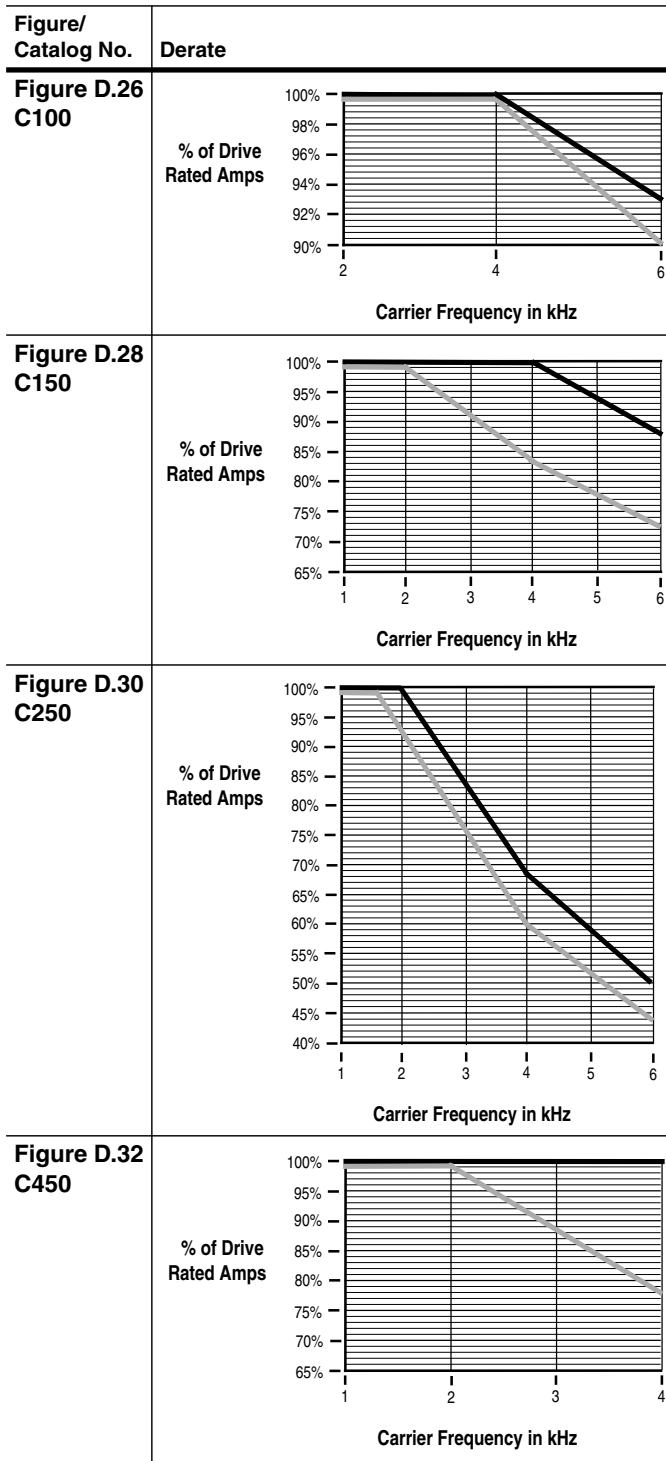
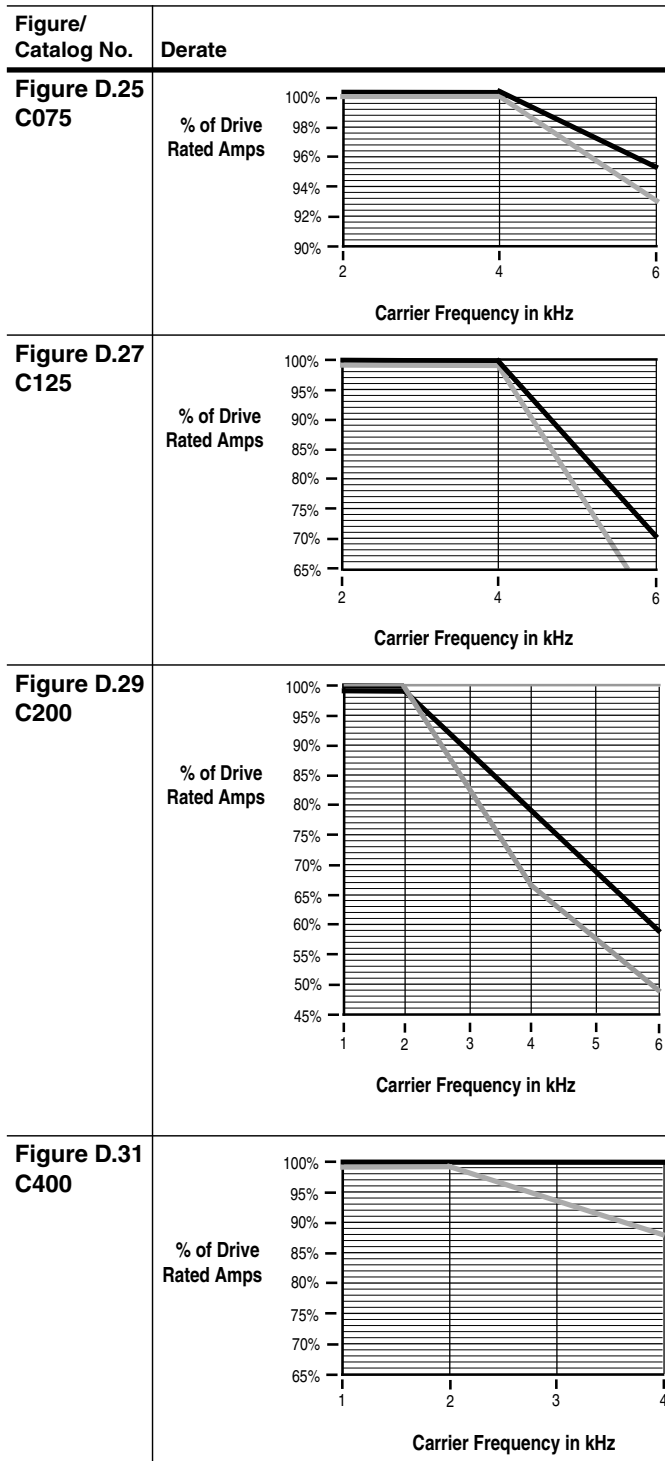
Standard rating for enclosed drive in 40°C ambient and open drive in 50°C ambient.  
 Derating factor for enclosed drive in ambient between 41°C and 50°C.

Figure/Catalog Number	Derate
<p><b>Figure D.11</b> <b>B015</b></p>	
<p><b>Figure D.12</b> <b>B025</b></p>	
<p><b>Figure D.13</b> <b>BX040</b></p>	
<p><b>Figure D.14</b> <b>B075</b></p>	
<p><b>Figure D.15</b> <b>B100</b></p>	

Standard rating for enclosed drive in 40°C ambient and open drive in 50°C ambient.  
 Derating factor for enclosed drive in ambient between 41°C and 50°C.



Standard rating for enclosed drive in 40°C ambient and open drive in 50°C ambient.  
 Derating factor for enclosed drive in ambient between 41°C and 50°C.



Standard rating for enclosed drive in 40°C ambient and open drive in 50°C ambient.  
 Derating factor for enclosed drive in ambient between 41°C and 50°C.

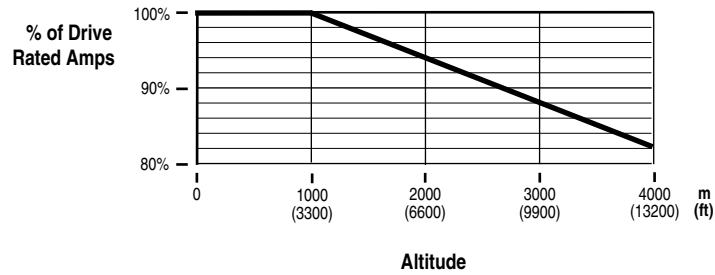
Figure/ Catalog No.	Derate	Figure/ Catalog No.	Derate
<b>Figure D.33 CP350</b>		<b>Figure D.34 CP400</b>	
<b>Figure D.35 CPR450</b>		<b>Figure D.36 C500</b>	
<b>Figure D.37 C600</b>		<b>Figure D.38 C650</b>	
<b>Figure D.39 C700C and C800C</b>			

% of Drive Rating 700 HP  
 % of Drive Rating 800 HP

Due to drive losses, the output voltage to the motor is affected by the AC input voltage to the drive. This reduced motor voltage may require more motor torque, and therefore current, to achieve rated motor horsepower. Though most applications do not require full rated motor horsepower at full speed, the following information is provided to assist with proper motor/drive selection.

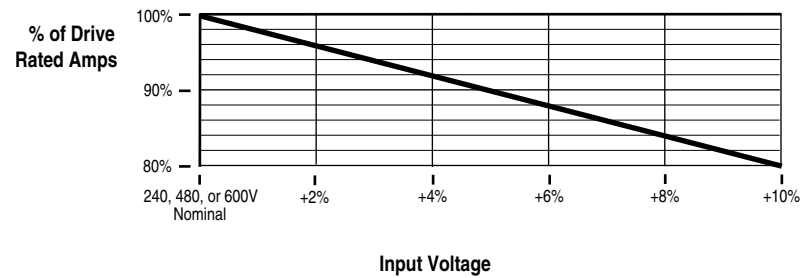
1. For 460V motors, operate with a minimum 480V Input AC line voltage.
2. Size the motor with the capability to operate with 8% more current.
3. Purchase a motor designed to operate at 440V.

**Figure D.40**  
**All Drive Ratings**

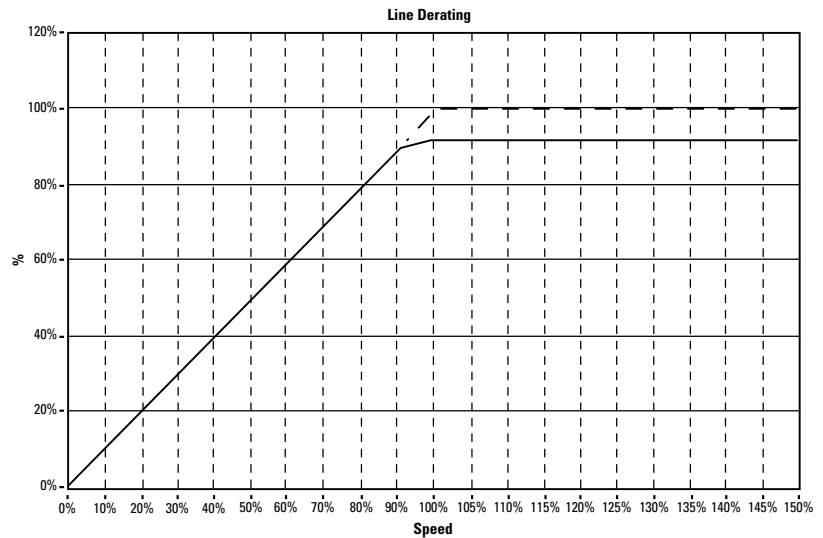


**Figure D.41**  
**Required Only for the following drives:**

- 1336E-A/B/C-025 - 18.5 kW (25 HP) at 8 kHz
- 1336E-A/B/C - 22 kW (30 HP) at 6-8 kHz
- 1336E-A/B/C - 45 kW (60 HP) at 6 kHz



**Figure D.42**  
**Drive Ratings**




## CE Conformity

### EMC Directive

This apparatus is tested to meet Council Directive 89/336 Electromagnetic Compatibility (EMC) using a technical construction file and the following standards:

- EN 50081-1, -2 — Generic Emission Standard
- EN 50082-1, -2 — Generic Immunity Standard

Declarations of Conformity to the European Union Directives are available. Please contact your Allen-Bradley Sales Representative.

Marked for all applicable directives <sup>1</sup>		
Emissions	EN 50081-1 EN 50081-2 EN 55011 Class A EN 55011 Class B	
Immunity	EN 50082-1 EN 50082-2 IEC 801-1, 2, 3, 4, 6, 8 per EN50082-1, 2	

<sup>1</sup> **Note:** Installation guidelines stated below must be adhered to.

**Important:** The conformity of the drive and filter to any standard does not guarantee that the entire installation will conform. Many other factors can influence the total installation and only direct measurements can verify total conformity.

### Requirements for Conforming Installation

The following six items *are required* for CE conformance:

1. Standard 1336 IMPACT Drive 0.37 – 485 kW (0.5 – 650 HP) CE compatible.
2. Factory installed EMC enclosure (-AE option) or field installed EMC Enclosure Kit (1336x-AEx — see page E-2).
3. Filter as called out on the following page.
4. Grounding as shown on page E-3.
5. Input power (source to filter) and output power (filter to drive and drive to motor) wiring must be braided, shielded cable with a coverage of 75% or better, metal conduit or other with equivalent or better attenuation, mounted with appropriate connectors. For shielded cable it is recommended to use a compact strain relief connector with double saddle clamp for filter and drive input and compact strain relief connector with EMI protection for motor output.
6. Control (I/O) and signal wiring must be in conduit or have shielding with equivalent attenuation.

**Filter****Filter Selection**

Filter Catalog Number	Three-Phase Volts	Used with...	Frame Reference
1336-RFB-7-A	200 – 240V	1336E-AQF05 – AQF10	A1
	380 – 480V	1336E-BRF05 – BRF20	A1 – A2
1336-RFB-16-A	200 – 240V	1336E-AQF15 – AQF20	A2
	380 – 480V	1336E-BRF30 – BRF50	A2 – A3
1336-RFB-30-A	200 – 240V	1336E-AQF30 – AQF50	A3
	380 – 480V	1336E-BRF75 – BRF100	A4
1336-RFB-27-B	200 – 240V	1336E-A007	B
	380 – 480V	1336E-B007 – B015	B
1336-RFB-48-B	200 – 240V	1336E-A010 – A015	B
	380 – 480V	1336E-B020 – B030	B
1336-RFB-80-C	200 – 240V	1336E-A020 – A030	C
	380 – 480V	1336E-BX040 – BX060	C
1336-RFB-150-D	200 – 240V	1336E-A040 – A050	D
	380 – 480V	1336E-B060 – B100	D
1336-RFB-180-D	200 – 240V	1336E-A060	D
	380 – 480V	1336E-B125 – BX150	D
1336-RFB-340-E	200 – 240V	1336E-A075 – A125	E
	380 – 480V	1336E-B150 – B250	E
1336-RFB-475-G	380 – 480V	1336E-BX250 – B350	G
1336-RFB-590-G	380 – 480V	1336E-B400 – B450	G
1336-RFB-670-G	380 – 480V	1336E-B500 – B600	G
Not available	380 – 480V	1336E-B700 – B800	H

**EMC Enclosure Kit Selection**

Frame Reference	Enclosure Kit Catalog Number		
	200 – 240V Rating	380 – 480V Rating	500 – 600V Rating
A1, A2, A3	1336E-AE3	1336E-AE3	—
A4	1336E-AE2	1336E-AE2	1336E-AE2
B	1336E-AE4	1336E-AE4	1336E-AE4
C	1336E-AE5	1336E-AE5	1336E-AE5
D	1336E-AE6	1336E-AE6	1336E-AE6
E	1336E-AE7	1336E-AE7	1336E-AE7
F – H	Not Available		

**RFI Filter Installation**

**Important:** Refer to the instructions supplied with the filter for details.

The RFI filter must be connected between the incoming AC supply line and the drive input terminals.



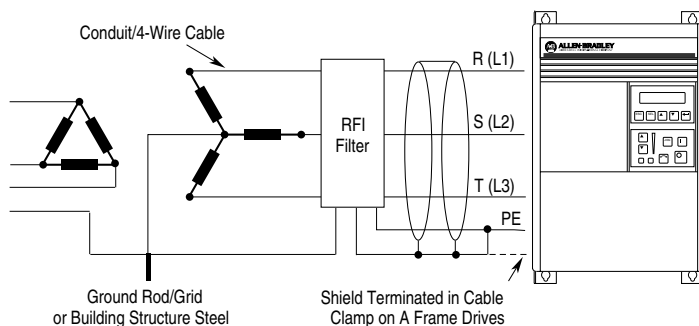
## RFI Filter Leakage Current

The RFI filter may cause ground leakage currents. Therefore a solid ground connection must be provided as shown below.



**ATTENTION:** To guard against possible equipment damage, RFI filters can only be used with AC supplies that are nominally balanced and grounded with respect to ground. In some installations, three-phase supplies are occasionally connected in a 3-wire configuration with one phase grounded (Grounded Delta). The filter must not be used in Grounded Delta supplies.

## Electrical Configuration



## Grounding

### RFI Filter Grounding

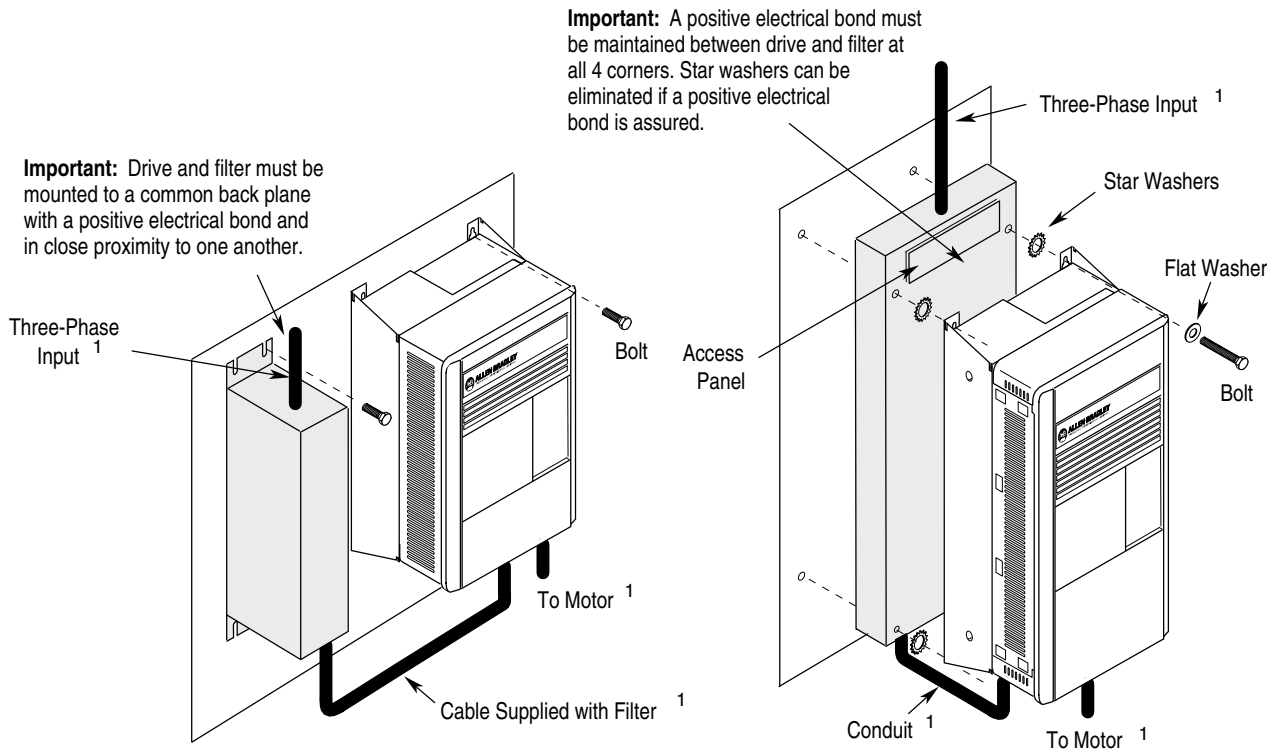
**Important:** Using the optional RFI filter may result in relatively high ground leakage currents. Surge suppression devices are also incorporated into the filter. Therefore, the filter must be permanently installed and solidly grounded (bonded) to the building power distribution ground. Ensure that the incoming supply neutral is solidly connected (bonded) to the same building power distribution ground.

Grounding must not rely on flexible cables and should not include any form of plug or socket that would permit inadvertent disconnection. Some local codes may require redundant ground connections. The integrity of all connections should be periodically checked.

## Mechanical Configuration

## Filter Mounting

**Important:** Drive and filter must be mounted to a common back plane with a positive electrical bond and in close proximity to one another.



**1336 IMPACT**  
Frames A1 - A4<sup>2</sup>

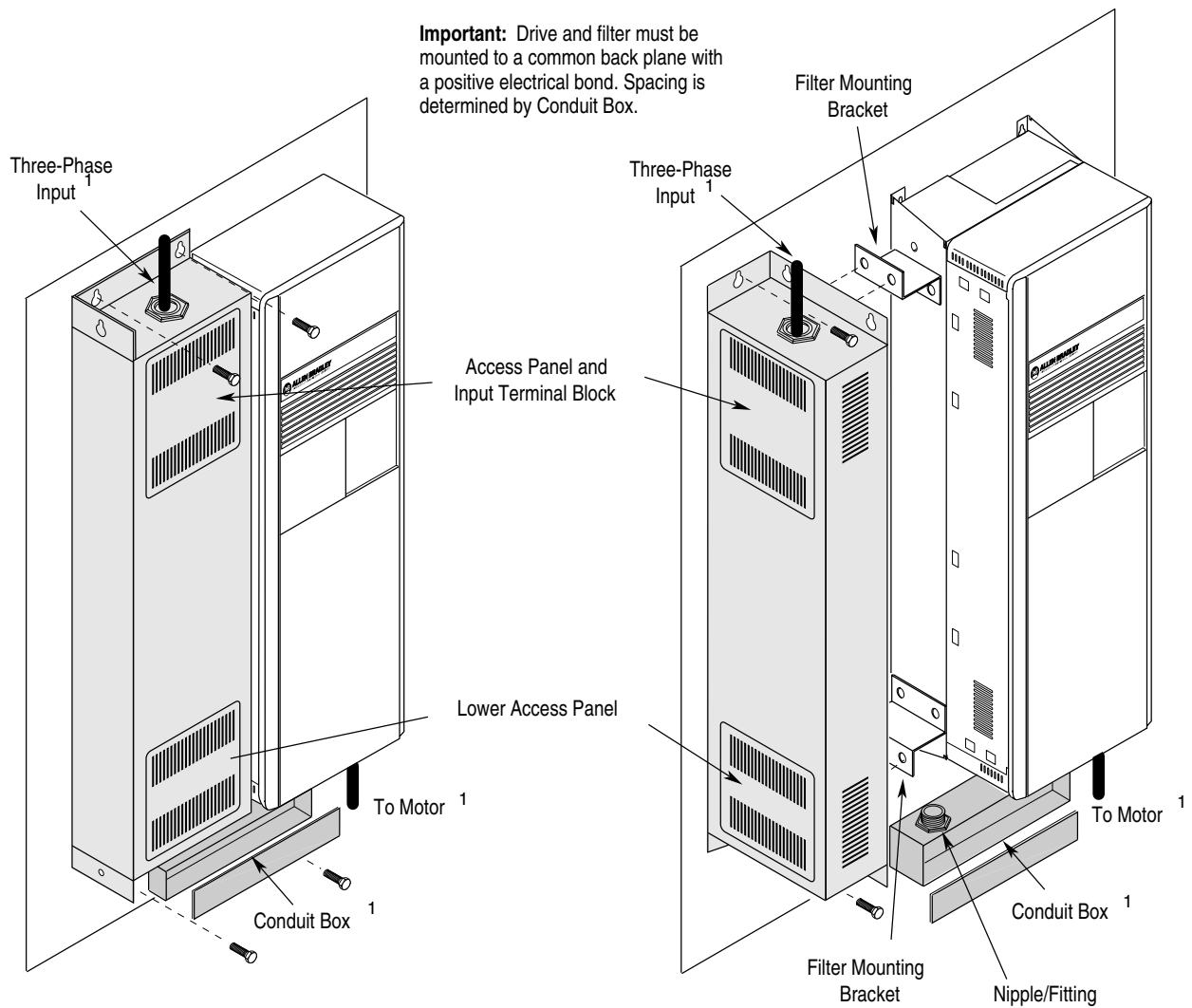
**1336 IMPACT**  
Frames B & C<sup>2</sup>

<sup>1</sup> Input power (source to filter) and output power (filter to drive and drive to motor) wiring must be in conduit or have shielding/armor with equivalent attenuation. Shielding/armor must be bonded to the metal bottom plate. See requirements 5 & 6 on page E-1.

<sup>2</sup> Refer to the Filter Selection table on page E-2 for frame references and corresponding catalog numbers.

## Filter Mounting, Continued

**Important:** Drive and filter must be mounted to a common back plane with a positive electrical bond. Spacing is determined by Conduit Box.



**1336 IMPACT**  
**(Through-the-Wall Mounting)**  
 Frames D & E<sup>2</sup>

**1336 IMPACT**  
**(Conventional Mounting)**  
 Frames D & E<sup>2</sup>

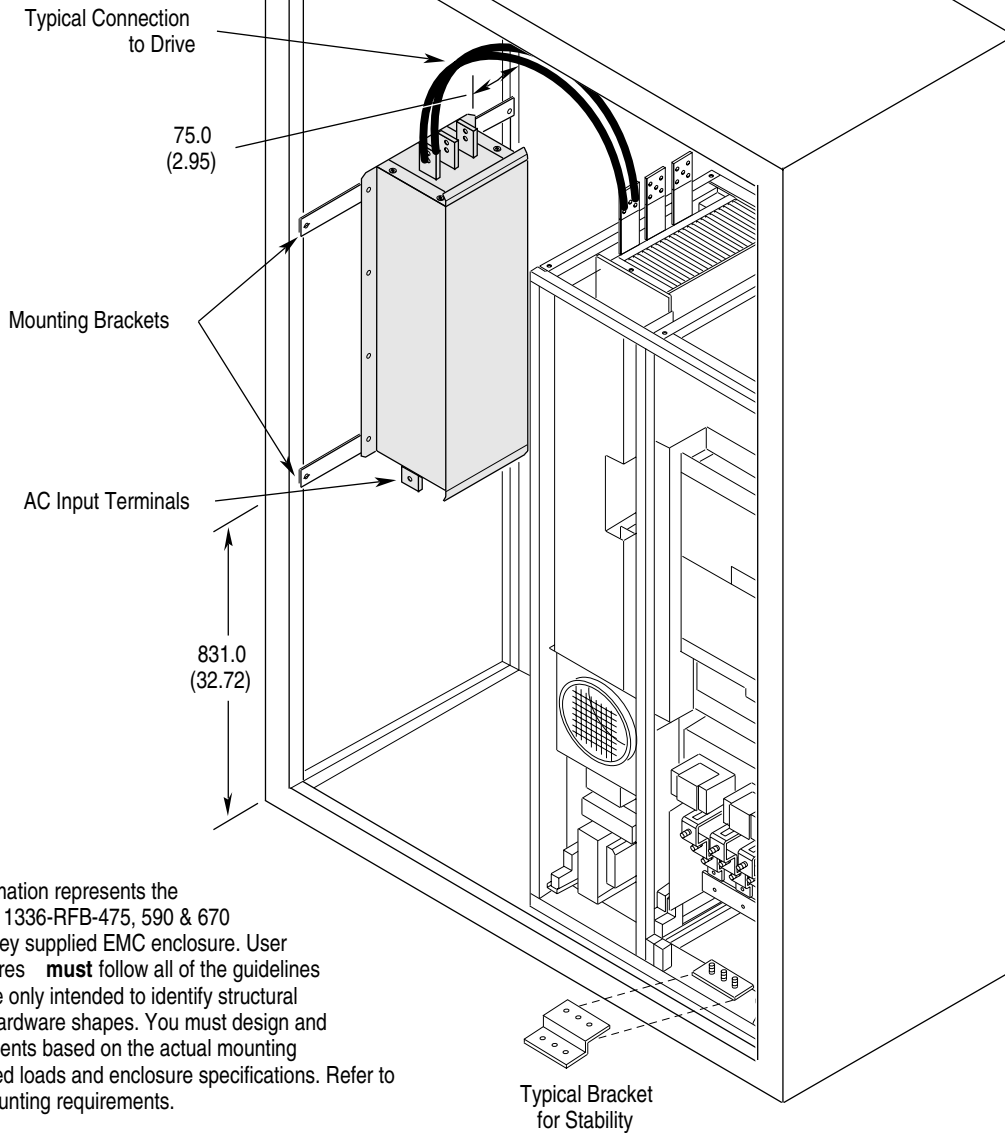
- 1 Input power (source to filter) and output power (filter to drive and drive to motor) wiring must be in conduit or have shielding/armor with equivalent attenuation. Shielding/armor must be bonded to the metal bottom plate. See requirements 5 & 6 on page E-1.
- 2 Refer to the Filter Selection table on page E-2 for frame references and corresponding catalog numbers.

## Filter Mounting, Continued

All Dimensions in Millimeters and (Inches)

**Important:** A positive electrical bond must be maintained between the enclosure and filter (including brackets), fans, and drive. To assure a positive electrical bond, any paint near all mounting points must be removed.

**Important:** Cooling fans are required for proper drive operation. Refer to the User-Supplied Enclosures section in Chapter 2 for CFM recommendations.



**Important:** This information represents the method used to mount 1336-RFB-475, 590 & 670 filters in an Allen-Bradley supplied EMC enclosure. User supplied EMC enclosures **must** follow all of the guidelines shown. Illustrations are only intended to identify structural mounting points and hardware shapes. You must design and fabricate steel components based on the actual mounting configuration, calculated loads and enclosure specifications. Refer to Chapter 2 for drive mounting requirements.

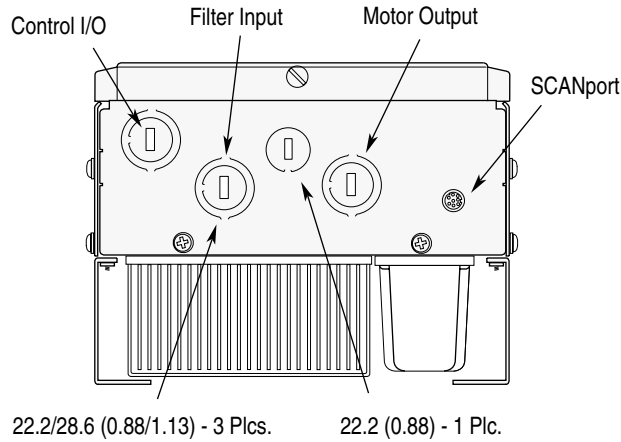
**1336 IMPACT**  
**(Typical Mounting)**  
 Frame G <sup>2</sup>

- 1 Input power (source to filter) and output power (filter to drive and drive to motor) wiring must be in conduit or have shielding/armor with equivalent attenuation. Shielding/armor must be bonded to the metal bottom plate. See requirements 5 & 6 on page E-1.
- 2 Refer to the Filter Selection table on page E-2 for frame references and corresponding catalog numbers.

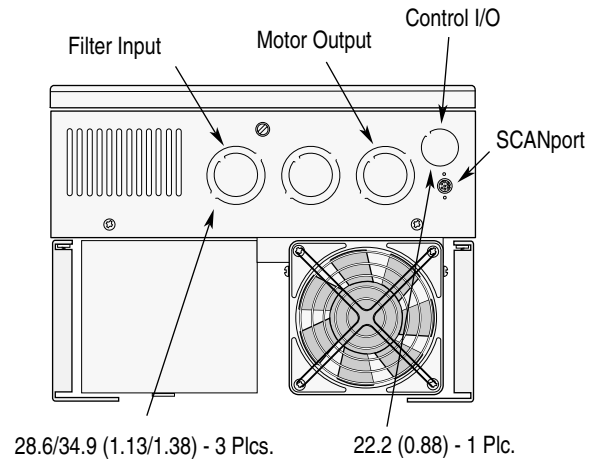
### Required Knockout Assignments

Dimensions are in Millimeters and (Inches)

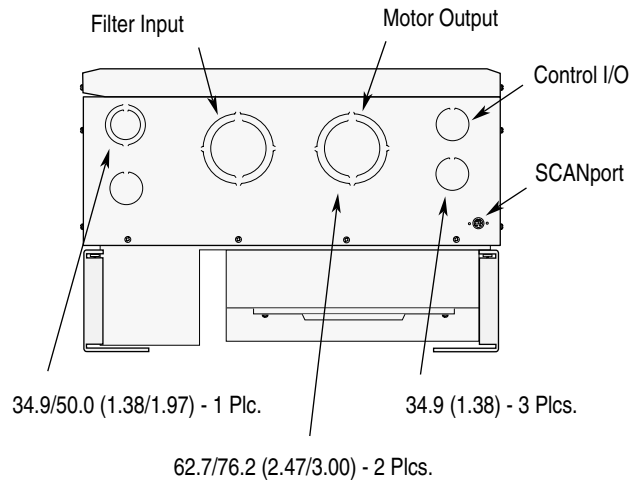
**Frames A1 through A4**



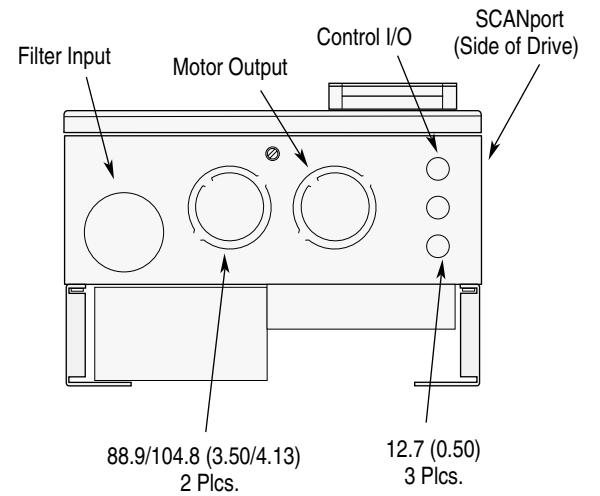
**Frames B and C**



**Frame D**



**Frame E**



**Notes:**

## Spare Parts Information

Current 1336 IMPACT drive spare parts information including recommended parts, catalog numbers and pricing can be obtained from the following sources:

Allen-Bradley home page on the World Wide Web at

**<http://www.ab.com>**

*then select...*

**“Drives”** *followed by...*

**“Product Information”** *and...*

**“Service Information...”**

Select document(s) 1060.pdf (230V drives) and/or 1070.pdf (460 and 575V drives).

- Standard Drives “AutoFax” service — an automated system that you can call to request a “faxed” copy of the spare parts information (or other technical document).

Simply call **440-646-6701** and follow the phone prompts to request document(s) **1060** (230V drives) and/or **1070** (460 and 575V drives).

**Notes:**



## Numerics

2/3 wire control, **8-4**  
 4 – 20 mA application, **9-11**  
 400% motor current, **9-7 to 9-8**

## A

Absolute Overspd, **11-17, B-31**  
 Accel Time 1, **11-20, B-8**  
 Accel Time 2, **11-20, B-8**  
 add/subtract function, **10-10 to 10-12**  
 alarms *See* warnings  
 An In 1 Offset, **11-33**  
 An In 1 Scale, **11-33**  
 An In 1 Value, **11-33**  
   wiring, **2-21**  
 An In 2 Filter BW, **11-54**  
 An In 2 Offset, **11-34**  
 An In 2 Scale, **11-34**  
 An In 2 Value, **11-33**  
   wiring, **2-21**  
 An In1 Filter BW, **11-54**  
 An Out 1 Offset, **11-35**  
 An Out 1 Scale, **11-35**  
 An Out 1 Value, **11-34**  
   wiring, **2-23**  
 An Out 2 Offset, **11-35**  
 An Out 2 Scale, **11-35**  
 An Out 2 Value, **11-35**  
 analog I/O *See* I/O, analog  
 autotune  
   Autotune Errors, **11-53, 13-7, 13-8**  
   Autotune Speed, **11-50**  
   Autotune Status, **11-48, 13-13**  
   Autotune Torque, **11-49**  
   Autotune/Dgn Sel, **11-51, 13-2**  
   checking status of, **11-48**  
   defined, **13-1**  
   faults, **13-7, 13-8**  
   flux current test, **13-8**  
   inductance test, **13-6**  
   inertia test, **13-9**  
   multiple opens, **13-5**  
   open transistor faults, **13-5**  
   phase rotation tests, **13-5**  
   power structure tests, **13-2**  
   resistance test, **13-7**  
   running individual tests, **13-2**  
   software fault, **13-5**  
   speed loop overview, **B-35, B-38**  
   status, **11-48, 13-13**  
   transistor diagnostic tests, **13-2**  
 Autotune Errors, **11-53, 13-7, 13-8**  
 Autotune Speed, **11-50, 13-9, 13-10**  
 Autotune Status, **11-48, 13-13, B-37**  
 Autotune Torque, **11-49, 13-9, 13-10, B-21**

Autotune/Dgn Sel, **11-51, 13-2**

## B

band function, **10-26**  
 bandwidth  
   adjusting, **13-11**  
 brake chopper, **9-3**  
 braking, **9-3 to 9-6**  
   bus regulator, **9-4**  
   DC braking, **9-6**  
     enable, **11-12**  
   dynamic braking, **9-3**  
   flux braking, **9-5**  
     enable, **11-12**  
     motor currents, **B-23**  
 bus cycles >5, **11-15, 11-16, 12-4, 12-18**  
 bus drop, **11-15, 11-16, 12-4, 12-18**  
 bus regulator  
   braking, **9-4**  
   explained, **B-21**  
 bus undervoltage, **11-15, 11-16, 12-4, 12-18**  
 bus voltage tracker  
   explained, **12-21**  
   setting slew rate, **11-12**  
 Bus/Brake Opts, **11-12, 12-16, 12-18**  
   for braking, **9-3 to 9-6**  
   for fast flux up, **12-20**  
   force precharge, **12-20**  
   select slew rate, **12-21**

## C

cable  
   common mode core, **2-9**  
   guidelines for length, **2-2 to 2-4**  
   output reactor, **2-9**  
   shielding requirements, **2-20**  
   terminator, **2-3 to 2-4**  
 catalog number explained, **1-3**  
 CE conformity, **E-1**  
 chopper brake, **9-3, 11-12**  
 Clr Flt/Res Mask, **11-41**  
 Command Spd Sts, **11-28**  
 common mode cores, **2-9**  
 communications fault, **8-7**  
 communications gateway, connecting, **2-24**  
 contents of manual, **1-2**  
 control interface option *See* L Option  
 current limits explained, **B-23**  
 Current Rate Lim, **11-28, B-37**

## D

Data In A1, **11-45**  
 Data In A2, **11-45**  
 Data In B1, **11-45**

Data In B2, 11-45  
 Data In C1, 11-46  
 Data In C2, 11-46  
 Data In D1, 11-46  
 Data In D2, 11-46  
 Data Out A1, 11-46  
 Data Out A2, 11-46  
 Data Out B1, 11-47  
 Data Out B2, 11-47  
 Data Out C1, 11-47  
 Data Out C2, 11-47  
 Data Out D1, 11-47  
 Data Out D2, 11-47  
 datalinks, 8-10 to 8-13, 11-45 to 11-47  
 DC Brake Current, 9-6, 9-7, 11-28  
 DC Brake Time, 9-6, 11-28  
 DC braking, 9-6  
   enabling, 11-12  
 DC Bus Voltage, 11-29  
 DC hold, 9-6  
   enable, 11-12  
 Decel Time 1, 11-20, B-8  
 Decel Time 2, 11-20, B-8  
 decelerating methods, 9-3 to 9-6  
 definitions, 1-3  
 derating guidelines, D-1  
 dimensions  
   A1 – A4, 3-5 to 3-6  
   B – H, 4-12 to 4-18  
 Dir/Ref Mask, 11-40  
 Dir/Ref Owner, 11-41  
 drive  
   fault detection overview, B-27  
 drive units  
   converting to rpm, 10-22  
 Drive/Inv Status, 11-13  
 Drive/Inv Sts 2, 11-60  
 Droop Percent, 11-21, B-18  
 dwell  
   start speed, 11-59, B-5  
   start time, 11-59, B-5  
   stop time, 11-14  
 dynamic braking, 9-3

## E

electrical interference, 2-28  
 Enc Pos Fdbk Hi, 11-72  
 Enc Pos Fdbk Low, 11-72  
 encoder, 5-11  
   making connections, 2-16  
 encoder feedback, 9-2  
   selecting, 11-24  
 Encoder PPR, 11-11, B-26  
 encoderless, 9-2, 12-29  
   selecting, 11-24  
 Error Filtr BW, 11-49, 13-11, B-18, B-37

## F

fan voltage, 4-10  
 Fast Flux Level, 11-28  
 fast flux up  
   enable, 11-12  
   explained, 12-20  
 Fault Select 1, 8-7, 11-15, 12-18  
 Fault Select 2, 11-16, 12-5 to 12-6, 12-24  
 Fault Status 1, 11-71  
 Fault Status 2, 11-71  
 faults, 12-2  
   Absolute Overspd, 12-10, B-31  
   Analog Spply Tol, 12-10, B-31  
   Autotune Diag, 12-8  
   Autotune Errors, 11-53, 13-7, 13-8  
   Bus Cycle >5, 12-14  
   Bus Drop, 12-14  
   Bus Undervlt, 12-14  
   clear queue, 12-7, C-10  
   configuring, 11-15, 11-16, 12-4 to 12-6  
   Desaturation, 12-14  
   Diff Drv Type, 12-10  
   EE Checksum, 12-10  
   External Flt In, 12-11  
   Feedback Loss, 12-27, B-29  
   Ground Fault, 12-14  
   HW Malfunction, 12-9, 12-15  
   Inv Overload, 12-9  
   Inv Overtmp Pnd, 12-9, B-31  
   Inv Overtmp Trp, 12-9, B-31  
   InvOvld Pend, 12-9  
   mA Input, 12-11  
   Math Limit, 12-11  
     explained, 12-24  
   Mtr Stall, 12-8, B-29  
   MtrOvld Pnd, B-29  
   MtrOvld Trp, B-29  
   MtrOvld Pnd, 12-8  
   MtrOvld Trp, 12-8  
   Open Circuit, 12-15  
   open transistor, 13-5  
   Overcurrent, 12-14  
   Overvoltage, 12-14  
   Param Limit, 12-11  
     explained, 12-22 to 12-24  
   precharge, 12-15  
   Prechrg Time, 12-14  
   ridethrough, 12-15  
   Ridethru Time, 12-14  
   SP 1 Timeout, 12-11  
   SP 2 Timeout, 12-12  
   SP 3 Timeout, 12-12  
   SP 4 Timeout, 12-12  
   SP 5 Timeout, 12-12  
   SP 6 Timeout, 12-12  
   SP Error, 12-12  
   Spd Fdbk Loss, 12-11  
   SW Malfunction, 12-10  
   viewing queue with HIM, 12-6

Fdbk Device Type, 9-1 to 9-3, 11-24, 13-11, B-13

Fdbk Filter BW, 11-25, B-15

Fdbk Filter Gain, 11-25, B-15

Fdbk Filter Sel, 11-25, 13-11, B-14, B-37  
for notch filters, B-23

features provided, 1-1

feedback device  
choosing filter, B-14  
choosing source, 9-1 to 9-3, B-13  
setting PPR rating, 11-11

Feedback Loss Fault, 12-27

filtering, RFI, E-3

flux braking, 9-5 to 9-6  
enabling, 11-12  
motor currents, B-23

Flux Current, 11-50, B-26

flux *See* fast flux up

Flux/Trim Owner, 11-43

flying start  
using, 9-14, 9-16, 9-17

frame designators defined, 1-4

Freq Track Filtr, 11-54

Fstart Select, 11-69

Fstart Speed, 11-70

Func 1 Eval Sel, 10-4, 11-62

Func 1 Mask/Val, 11-61

Func 2 Eval Sel, 10-4, 11-63

Func 2 Mask/Val, 11-63

Func 3 Eval Sel, 10-4, 11-65

Func 3 Mask/Val, 11-64

function block  
add/subtract, 10-10 to 10-12  
band, 10-26  
evaluating inputs, 10-4  
hysteresis, 10-23 to 10-25  
logical add/subtract, 10-26 to 10-27  
logical multiply/divide, 10-27 to 10-28  
maximum/minimum, 10-12 to 10-14  
multiply/divide, 10-18 to 10-20  
overview, 10-1 to 10-3  
scale, 10-20 to 10-23  
state machine, 10-8 to 10-10  
timer delay, 10-5 to 10-8  
up/down counter, 10-14

Function In1, 11-61

Function In10, 11-73

Function In2, 11-62

Function In3, 11-64

Function In4, 11-65

Function In5, 11-66

Function In6, 11-66

Function In7, 11-67

Function In8, 11-67

Function In9, 11-73

Function Output1, 11-69

Function Output2, 11-69

Function Sel, 11-68

functions  
determining ownership, 8-5  
masking, 8-6  
ownership of, 8-3

fusing requirements  
A1 – A4 frames, 3-4  
B – H frames, 4-11

Fwd Speed Limit, 11-20, 13-9, B-7

## G

gains  
integral, 13-10, B-17  
Kf, 13-13, B-18  
Ki, 13-10, B-17  
Kp, 13-10, B-17  
proportional, 13-10, B-17  
scaling, B-18  
speed overshoot, 13-13

gateway *See* communications gateway

grounding your drive, 2-14 to 2-17

## H

heat dissipation requirements, 2-9

HIM *See* Human Interface Module (HIM)

Human Interface Module (HIM)  
basics, 6-4  
compatibility information, C-12  
control status mode, C-9  
creating links, 6-12, C-11  
description, C-1  
display mode, C-5  
changing bit definitions, C-5 to C-6  
downloading parameter profile, C-8  
EEProm mode, C-7  
menu tree, C-4  
password mode, C-10 to C-12  
process mode, C-6  
program mode, C-5  
removing, C-13  
resetting default parameter values, C-7  
search mode, C-8  
uploading parameter profile, C-7  
viewing fault/warning queues, 12-6, C-9

hysteresis function, 10-23 to 10-25

## I

I/O  
analog, 9-8 to 9-11  
associated parameters, 7-1  
offset for input, 7-4 to 7-6  
offset for output, 7-6 to 7-8  
scale for input, 7-4 to 7-6  
scale for output, 7-6 to 7-8  
setting SCANport parameters, 8-14  
setting up, 7-1 to 7-8

configuring

- 4 – 20 mA, 7-8
- analog, 7-4 to 7-8
- L Option, 7-12
- output relay, 7-10
- pulse input, 7-11 to 7-12
- hard wiring, 2-21
  - analog inputs, 2-21
  - analog outputs, 2-23
  - discrete outputs, 2-23
  - reference signal connections
    - frames A1 – A4, 3-3
    - frames B – H, 4-8
- I<sup>2</sup>T *See* motor overload
- Id Offset, 11-73
- inertia
  - measuring, B-36
- input fusing, 2-27
- input/output ratings, A-4
- Int Torque Ref, 11-73
- internal drive units, 7-1
- inverter
  - current rating, 11-11
  - over temperature, 11-16, 11-17, 12-5
  - overload overview, B-32
  - voltage rating, 11-11
- Inverter Amps, 11-11
- Inverter Dgn1, 11-52, 13-4
- Inverter Dgn2, 11-52, 13-4
- inverter overload, 11-16, 11-17, 12-5
- Inverter Volts, 11-11
- Iq %, 11-31, B-26
- Iq Offset, 11-73
- IT inverter protection, B-33

## J

- jog
  - selecting references, B-5
- Jog Speed 1, 11-19
- Jog Speed 2, 11-19
- Jog1/Jog2 Owner, 11-42

## K

- Kf Freq Reg, 11-53
- Kf Speed Loop, 11-49, 13-11, 13-13, B-18, B-37
- Ki Freq Reg, 11-53
- Ki Speed Loop, 11-48, 13-12, B-18, B-37
- Kp Freq Reg, 11-53
- Kp Speed Loop, 11-48, 13-12, B-18, B-37

## L

- L Option
  - available functions, 5-3
  - changing input mode, 5-8
  - choosing mode, 5-4

- configuring, 7-12
- connections, 5-6 to 5-7
- description, 5-2
- encoder, 5-11
- examples of, 5-9 to 5-10
- requirements
  - L4, 5-11
  - L5, 5-12
  - L6, 5-13
  - L7E, 5-14
  - L8E, 5-15
  - L9E, 5-16
- wiring, 5-8
- L Option In Sts, 11-38
- L Option Mode, 9-14, 11-37
- Language Select, 11-10
- Leak Inductance, 11-50
- Line Undervolts, 11-17, 12-16, 12-19
- links
  - creating, 6-12, C-11
  - pre-defined, 6-13
  - removing, 6-13, C-12
  - understanding, 6-12
- Logic Cmd Input, 11-60
- Logic Input, 9-7
- Logic Input Sts, 8-1 to 8-3, 11-13, B-5
- Logic Options, 9-7, 11-14, B-7
- logical add/subtract function, 10-26 to 10-27
- logical multiply/divide function, 10-27 to 10-28
- loss of communications, 8-7
- lug kits, 4-6

## M

- mA In Filter BW, 11-54
- mA input
  - loss of connection, 11-15, 11-16, 12-4
- mA Input Offset, 11-34
- mA Input Scale, 11-34
- mA Input Value, 11-34
- mA Out Offset, 11-36
- mA Out Scale, 11-36
- mA Out Value, 11-35
- manuals
  - related, 1-3
- masking functions, 8-6
- math limit, 11-16, 11-17, 12-5
- Max Fwd Spd Trim, 11-24
- Max Mtr Current, 9-8, 11-59
- Max Rev Spd Trim, 11-24
- maximum/minimum function, 10-12 to 10-14
- Min Flux Level, 11-26, 13-11, B-21
- Min Speed Limit, 11-69
- Mop Increment, 9-14, 11-38
- Mop Value, 9-14, 11-38
- MOP, using, 9-14
- motor cables

- selecting, **2-18 to 2-20**
- motor control board overview, **B-2**
- Motor Current, **11-29**
- motor feedback source, **9-1 to 9-3**
- Motor Flux %, **11-30, B-21**
- Motor Frequency, **11-30, B-26**
- motor information
  - cables
    - length of, **2-2**
    - selecting, **2-18 to 2-20**
  - changing audible noise level, **11-11**
  - choosing feedback source, **9-1 to 9-3**
  - current rating, **11-10**
  - frequency rating, **11-10**
  - horsepower rating, **11-10**
  - motor poles, **11-11**
  - speed (rpm), **11-10**
  - voltage rating, **11-10**
- motor overload, **11-16, 11-17, 12-5**
- Motor Overload %, **11-17**
- Motor Poles, **11-11, B-26**
- Motor Power %, **11-30**
- motor simulation mode, **11-24**
- Motor Speed, **11-28**
- Motor Stall Time, **11-17, B-29**
- motor stalled, **11-16, 11-17, 12-5**
- Motor Torque %, **11-29**
- Motor Voltage, **11-29**
- Motor Voltage %, **11-73, 11-74, 11-75, 11-76, 11-77, 11-78, 11-79, 11-80, 11-81, 11-82, 11-83, 11-84**
- mounting your drive, **2-10**
- MOV ratings, **2-26**
- multiply/divide function, **10-18**

## N

- Nameplate Amps, **11-10**
- Nameplate HP, **11-10**
- Nameplate Hz, **11-10**
- Nameplate RPM, **11-10**
- Nameplate Volts, **11-10**
- Ncfg Flt Status, **11-70**
- Neg Mtr Cur Lim, **9-7, 11-27, 13-9, B-22, B-23**
- Neg Torque Lim, **11-27, B-21, B-22**
- Notch Filtr Freq, **11-55, B-23**
- Notch Filtr Q, **11-55, B-23**
- NTC foldback protection, **B-33**

## O

- open circuit, **11-15, 11-16, 12-4**
- options available, **1-2**
- output devices *See* I/O
- output reactor guidelines, **2-2 to 2-4**
- output relay, configuring, **7-10**
- ownership of drive functions, **8-3**

## P

- parameter limit, **11-16, 11-17, 12-5**
- parameters
  - Absolute Overspd, **11-17, B-31**
  - Accel Time 1, **11-20, B-8**
  - Accel Time 2, **11-20, B-8**
  - alphabetical listing, **11-8**
  - An In 1 Offset, **11-33**
  - An In 1 Scale, **11-33**
  - An In 1 Value, **11-33**
  - An In 2 Offset, **11-34**
  - An In 2 Scale, **11-34**
  - An In 2 Value, **11-33**
  - An In1 Filter BW, **11-54**
  - An In2 Filter BW, **11-54**
  - An Out 1 Offset, **11-35**
  - An Out 1 Scale, **11-35**
  - An Out 1 Value, **11-34**
  - An Out 2 Offset, **11-35**
  - An Out 2 Scale, **11-35**
  - An Out 2 Value, **11-35**
  - Autotune Errors, **11-53, 13-7, 13-8**
  - Autotune Speed, **11-50, 13-9, 13-10**
  - Autotune Status, **11-48, 13-13, B-37**
  - Autotune Torque, **11-49, 13-9, 13-10, B-21**
  - Autotune/Dgn Sel, **11-51, 13-2**
  - Bus Options, **12-18**
  - Bus/Brake Opts, **11-12, 12-16 to 12-18**
    - for braking, **9-3 to 9-6**
    - for fast flux up, **12-20**
    - force precharge, **12-20**
    - select slew rate, **12-21**
  - Clr Flt/Res Mask, **11-41**
  - Command Spd Sts, **11-28**
  - conventions, **11-9**
  - Current Rate Lim, **11-28, B-37**
  - Data In A1, **8-8, 11-45**
  - Data In A2, **8-8, 11-45**
  - Data In B1, **8-8, 11-45**
  - Data In B2, **8-8, 11-45**
  - Data In C1, **8-8, 11-46**
  - Data In C2, **8-8, 11-46**
  - Data In D1, **8-8, 11-46**
  - Data In D2, **8-8, 11-46**
  - Data Out A1, **8-8, 11-46**
  - Data Out A2, **8-8, 11-46**
  - Data Out B1, **8-8, 11-47**
  - Data Out B2, **8-8, 11-47**
  - Data Out C1, **8-8, 11-47**
  - Data Out C2, **8-8, 11-47**
  - Data Out D1, **8-8, 11-47**
  - Data Out D2, **8-8, 11-47**
  - DC Brake Current, **9-6, 9-7, 11-28**
  - DC Brake Time, **9-6, 11-28**
  - DC Bus Voltage, **11-29**
  - Decel Time 1, **11-20, B-8**
  - Decel Time 2, **11-20, B-8**
  - destination explained, **6-12**
  - Dir/Ref Mask, **11-40**

Dir/Ref Owner, 11-41  
downloading profile, C-8  
Drive/Inv Status, 11-13  
Drive/Inv Sts 2, 11-60  
Droop Percent, 11-21, B-18  
Enc Pos Fdbk Hi, 11-72  
Enc Pos Fdbk Low, 11-72  
Encoder PPR, 11-11, B-26  
Error Filtr BW, 11-49, 13-11, B-18, B-37  
Fast Flux Level, 11-28  
Fault Select 1, 8-7, 8-8, 11-15, 12-4 to 12-5, 12-18  
Fault Select 2, 11-16, 12-5 to 12-6, 12-24  
Fault Status 1, 11-71  
Fault Status 2, 11-71  
Fdbk Device Type, 9-1 to 9-3, 11-24, 13-11, B-13  
Fdbk Filter BW, 11-25, B-15  
Fdbk Filter Gain, 11-25, B-15  
Fdbk Filter Sel, 11-25, 13-11, B-14, B-37  
    for notch filters, B-23  
file and group organization, 11-1  
Flux Current, 11-50, B-26  
Flux/Trim Owner, 11-43  
Freq Track Filtr, 11-54  
Fstart Select, 11-69  
Fstart Speed, 11-70  
Func 1 Eval Sel, 10-4  
Func 1 Eval/Sel, 11-62  
Func 1 Mask/Val, 11-61  
Func 2 Eval Sel, 10-4, 11-63  
Func 2 Mask/Val, 11-63  
Func 3 Eval Sel, 10-4  
Func 3 Eval/Sel, 11-65  
Func 3 Mask/Val, 11-64  
Function In1, 11-61  
Function In10, 11-73  
Function In2, 11-62  
Function In3, 11-64  
Function In4, 11-65  
Function In5, 11-66  
Function In6, 11-66  
Function In7, 11-67  
Function In8, 11-67  
Function In9, 11-73  
Function Output1, 11-69  
Function Output2, 11-69  
Function Sel, 11-68  
Fwd Speed Limit, 11-20, 13-9, B-7  
Id Offset, 11-73  
Int Torque Ref, 11-73  
Inverter Amps, 11-11  
Inverter Dgn1, 11-52, 13-4  
Inverter Dgn2, 11-52, 13-4  
Inverter Volts, 11-11  
Iq %, 11-31, B-26  
Iq Offset, 11-73  
Jog Speed 1, 11-19  
Jog Speed 2, 11-19  
Jog1/Jog2 Owner, 11-42  
Kf Freq Reg, 11-53  
Kf Speed Loop, 11-49, 13-11, 13-13, B-18, B-37  
Ki Freq Reg, 11-53  
Ki Speed Loop, 11-48, 13-12, B-18, B-37  
Kp Freq Reg, 11-53  
Kp Speed Loop, 11-48, 13-12, B-18, B-37  
L Option In Sts, 11-38  
L Option Mode, 9-14, 11-37  
Language Select, 11-10  
Leak Inductance, 11-50  
Line Undervolts, 11-17, 12-16, 12-19  
Logic Cmd Input, 11-60  
Logic Input, 9-7  
Logic Input Sts, 8-1 to 8-3, 11-13, B-5  
Logic Options, 11-14, B-7  
mA In Filter BW, 11-54  
mA Input Offset, 11-34  
mA Input Scale, 11-34  
mA Input Value, 11-34  
mA Out Offset, 11-36  
mA Out Scale, 11-36  
mA Out Value, 11-35  
Max Fwd Spd Trim, 11-24  
Max Mtr Current, 9-8, 11-59  
Max Rev Spd Trim, 11-24  
Min Flux Level, 11-26, 13-11, B-21  
Min Speed Limit, 11-69  
Mop Increment, 9-14, 11-38  
Mop Value, 9-14, 11-38  
Motor Current, 11-29  
Motor Flux %, 11-30, B-21  
Motor Frequency, 11-30, B-26  
Motor Overload %, 11-17  
Motor Poles, 11-11, B-26  
Motor Power %, 11-30  
Motor Speed, 11-28  
Motor Stall Time, 11-17, B-29  
Motor Torque %, 11-29  
Motor Voltage, 11-29  
Motor Voltage %, 11-73, 11-74, 11-75, 11-76, 11-77, 11-78, 11-79, 11-80, 11-81, 11-82, 11-83, 11-84  
Nameplate Amps, 11-10  
Nameplate HP, 11-10  
Nameplate Hz, 11-10  
Nameplate RPM, 11-10  
Nameplate Volts, 11-10  
Ncfg Flt Status, 11-70  
Neg Mtr Cur Lim, 9-7, 11-27, 13-9, B-22, B-23  
Neg Torque Lim, 11-27, B-21, B-22  
Notch Filtr Freq, 11-55, B-23  
Notch Filtr Q, 11-55, B-23  
numerical listing, 11-5  
Pos Mtr Cur Lim, 9-7, 11-27, 13-9, B-22, B-23  
Pos Torque Lim, 11-27, B-21, B-22  
PTrim Feedback, 11-21, B-11  
PTrim Filter BW, 11-22  
PTrim Hi Limit, 11-23, B-12  
PTrim Ki, 11-22, B-11  
PTrim Kp, 11-23, B-11  
PTrim Lo Limit, 11-23, B-12  
PTrim Out Gain, 11-24  
PTrim Output, 11-21, B-11

- PTrim Preload, **11-22, B-11**
- PTrim Reference, **11-21, B-11**
- PTrim Select, **11-22, B-11**
- Pulse In Offset, **7-11 to 7-12, 11-39**
- Pulse In PPR, **7-11 to 7-12, 11-38**
- Pulse In Scale, **7-11 to 7-12, 11-38**
- Pulse In Value, **7-11 to 7-12, 11-39**
- PWM Frequency, **11-11**
- PwrUp Flt Status, **11-70**
- Ramp/CIFlt Owner, **11-43**
- Regen Power Lim, **11-27, 13-9, B-21**
  - for bus regulator braking, **9-3**
- Relay Config 1, **7-10, 11-36**
- Relay Config 2, **7-10, 11-56**
- Relay Config 3, **7-10, 11-57**
- Relay Config 4, **7-10, 11-58**
- Relay Setpoint 1, **7-10, 11-37**
- Relay Setpoint 2, **7-10, 11-56**
- Relay Setpoint 3, **7-10, 11-57**
- Relay Setpoint 4, **7-10, 11-58**
- resetting to default, **C-7**
- Rev Speed Limit, **11-20, 13-9, B-7**
- Run Inhibit Sts, **11-14**
- Scaled Spd Fdbk, **11-24**
- S-Curve Percent, **11-21, B-8**
- Service Factor, **11-11**
- Slave Torque %, **11-26, B-22**
- Slip Gain, **11-50, B-26**
- source explained, **6-12**
- SP 2 Wire Enable, **8-4, 11-54**
- SP An In1 Scale, **8-15, 11-44**
- SP An In1 Select, **8-15, 11-44**
- SP An In1 Value, **8-15, 11-44**
- SP An In2 Scale, **11-45**
- SP An In2 Select, **11-44**
- SP An In2 Value, **11-44**
- SP An Output, **8-15, 11-45**
- SP Enable Mask, **11-39**
- Spd Desired BW, **11-49, 13-10, 13-11, B-18**
- Spd Error, **11-72**
- Spd Reg Output, **11-72**
- Spd/Trq Mode Sel, **7-12, 11-26, B-22**
- Speed Ref 1, **11-18**
- Speed Ref 1 Frac, **11-18**
- Speed Ref 2, **11-18**
- Speed Ref 3, **11-18**
- Speed Ref 4, **11-18**
- Speed Ref 5, **11-19**
- Speed Ref 6, **11-19**
- Speed Ref 7, **11-19**
- Speed Scale 1, **11-18**
- Speed Scale 7, **11-19**
- Start Dwell Spd, **11-59, B-5**
- Start Dwell Time, **11-59, B-5**
- Start/Jog Mask, **11-40**
- Start/Stop Owner, **11-42**
- Stator Resistnce, **11-50**
- Stop Dwell Time, **11-14**
- Test Data 1, **11-31**
  - check for fluxing time, **12-20**
  - for calculated undervoltage, **12-19**
  - for precharge status, **12-19**
- Test Data 2, **11-31**
  - for math limit fault, **12-25 to 12-27**
  - for parameter limit fault, **12-22**
- Test Select 1, **11-31**
  - check for fluxing time, **12-20**
  - for calculated undervoltage, **12-19**
  - for precharge status, **12-19**
- Test Select 2, **11-32**
  - for math limit fault, **12-25 to 12-27**
  - for parameter limit fault, **12-22**
- Torque Limit Sts, **11-30, B-21**
- Torque Ref 1, **11-26, B-22**
- Total Inertia, **11-48, 13-10, 13-11**
- Trans Dgn Config, **11-51, 13-3**
- uploading profile, **C-7**
- Vd Max, **11-51**
- Vq Max, **11-51**
- Warning Select 1, **8-7, 8-8, 11-16, 12-4 to 12-5, 12-18**
- Warning Select 2, **11-17, 12-24**
- Warning Status 1, **11-71**
- Warning Status 2, **11-72**
- Zero Speed Tol, **11-15**
- password, **C-10**
- Pos Mtr Cur Lim, **9-7, 11-27, 13-9, B-22, B-23**
- Pos Torque Lim, **11-27, B-21, B-22**
- power
  - applying, **6-2**
  - before applying, **6-1**
  - connecting to drive, **2-25**
  - input fusing, **2-27**
    - requirements for frames A1 – A4, **3-4**
    - requirements for frames B – G, **4-11**
  - isolation-type transformer requirements, **2-27**
  - line reactor requirements, **2-27**
  - understanding limits, **B-21**
  - wiring, **2-17**
    - frames A1 – A4, **3-1**
    - frames B – G, **4-1**
- precharge
  - checking status of, **12-19**
  - common bus, **11-12**
  - configuring faults/warnings for, **12-18**
  - disable multiple, **11-12**
  - explained, **12-15**
  - force exit, **11-12**
  - options for, **11-12**
  - timeout, **11-15, 11-16, 12-4, 12-18**
- process trim
  - enable, **11-22**
  - explained, **B-11**
  - overview, **B-10**
  - preset integrator option, **11-22**
  - PTrim Feedback, **11-21, B-11**
  - PTrim Filter BW, **11-22**
  - PTrim Hi Limit, **11-23, B-12**
  - PTrim Ki, **11-22, B-11**
  - PTrim Kp, **11-23, B-11**

PTrim Lo Limit, 11-23, **B-12**  
 PTrim Out Gain, 11-24  
 PTrim Output, 11-21, **B-11**  
 PTrim Preload, 11-22, **B-11**  
 PTrim Reference, 11-21, **B-11**  
 PTrim Select, 11-22, **B-11**  
 select speed inputs, 11-22  
 set output option, 11-22  
 trim limiter, 11-22  
 trim speed reference, 11-22  
 trim torque reference, 11-22  
 programmable relay  
   Relay Config 1, 11-36  
   Relay Config 2, 11-56  
   Relay Config 3, 11-57  
   Relay Config 4, 11-58  
   Relay Setpoint 1, 11-37  
   Relay Setpoint 2, 11-56  
   Relay Setpoint 3, 11-57  
   Relay Setpoint 4, 11-58  
   wiring, 2-23  
 PTrim Feedback, 11-21, **B-11**  
 PTrim Filter BW, 11-22  
 PTrim Hi Limit, 11-23, **B-12**  
 PTrim Ki, 11-22, **B-11**  
 PTrim Kp, 11-23, **B-11**  
 PTrim Lo Limit, 11-23, **B-12**  
 PTrim Out Gain, 11-24  
 PTrim Output, 11-21, **B-11**  
 PTrim Preload, 11-22, **B-11**  
 PTrim Reference, 11-21, **B-11**  
 PTrim Select, 11-22, **B-11**  
 publications  
   related, 1-3  
 Pulse In Offset, 7-11 to 7-12, 11-39  
 Pulse In PPR, 7-11 to 7-12, 11-38  
 Pulse In Scale, 7-11 to 7-12, 11-38  
 Pulse In Value, 7-11 to 7-12, 11-39  
 pulse input, 7-11 to 7-12  
 PWM Frequency, 11-11  
 PwrUp Flt Status, 11-70

## R

Ramp/CIFlt Owner, 11-43  
 Regen Power Lim, 11-27, 13-9, **B-21**  
   for bus regulator braking, 9-3  
 Relay Config 1, 7-10, 11-36  
 Relay Config 2, 7-10, 11-56  
 Relay Config 3, 7-10, 11-57  
 Relay Config 4, 7-10, 11-58  
 Relay Setpoint 1, 7-10, 11-37  
 Relay Setpoint 2, 7-10, 11-56  
 Relay Setpoint 3, 7-10, 11-57  
 Relay Setpoint 4, 7-10, 11-58  
 relay wiring, 2-23  
 remote pot, 9-12 to 9-14

Rev Speed Limit, 11-20, 13-9, **B-7**  
 RFI filter, 2-28 to 2-29  
   grounding, 2-17  
   installing, 2-29  
 ridethrough  
   disable all, 11-12  
   explained, 12-15  
   timeout, 11-15, 11-16, 12-4, 12-18  
 rpm  
   converting to drive units, 10-22  
 Run Inhibit Sts, 11-14

## S

scale function, 10-20 to 10-23  
 Scaled Spd Fdbk, 11-24  
 scaling, 9-8  
 SCANport  
   Clr Flt/Res Mask, 11-41  
   configuring controls, 8-3 to 8-7  
   connections for frames A1 – A4, 1-5  
   connections for frames B – H, 1-6  
   control ownership, 8-3  
   determining function ownership, 8-5  
   Dir/Ref Mask, 11-40  
   Dir/Ref Owner, 11-41  
   disabling control functions, 8-6  
   enabling control functions, 8-6  
   Flux/Trim Owner, 11-43  
   I/O image, 8-8  
   Jog1/Jog2 Owner, 11-42  
   logic evaluation block, 8-2  
   Logic Input Sts parameter, 8-1 to 8-3  
   loss of communications, 11-15, 11-16, 12-4  
     fault, 8-7  
   masking functions, 8-6 to 8-7  
   parameter interactions, 8-3  
   Ramp/CIFlt owner, 11-43  
   receiving analog input, 8-15  
   setting SP Errors, 8-8  
   setting up parameters, 8-14  
   SP 2 Wire Enable, 11-54  
   SP An In1 Scale, 11-44  
   SP An In1 Select, 11-44  
   SP An In1 Value, 11-44  
   SP An In2 Scale, 11-45  
   SP An In2 Select, 11-44  
   SP An In2 Value, 11-44  
   SP An Output, 11-45  
   SP Enable Mask, 11-39  
   Start/Jog Mask, 11-40  
   Start/Stop Owner, 11-42  
   supported messages, 8-13  
   used with Flex I/O Module, 8-12  
   used with RIO Communications Module, 8-12  
   used with SLC to SCANport module, 8-10  
   used with the DeviceNet Communications Module, 8-13  
   used with the Serial Communications Module, 8-11  
   using the capabilities, 7-10



S-Curve Percent, 11-21, **B-8**  
 Service Factor, 11-11  
 Slave Torque %, 11-26, **B-22**  
 Slip Gain, 11-50, **B-26**  
 software block diagram, **A-6**  
 SP 2 Wire Enable, 8-4, 11-54  
 SP An In1 Scale, 8-15, 11-44  
 SP An In1 Select, 8-15, 11-44  
 SP An In1 Value, 8-15, 11-44  
 SP An In2 Scale, 11-45  
 SP An In2 Select, 11-44  
 SP An In2 Value, 11-44  
 SP An Output, 8-15, 11-45  
 SP Enable Mask, 11-39  
 Spd Desired BW, 11-49, 13-10, 13-11, **B-18**  
 Spd Error, 11-72  
 Spd Reg Output, 11-72  
 Spd/Trq Mode Sel, 7-12, 11-26, **B-22**  
 specifications, **A-1, A-5**  
 speed  
     adjusting for changes in load, **B-18**  
     feedback overview, **B-13**  
     loss of feedback, 11-16, 11-17, 12-5  
     PI regulator overview, **B-16 to B-18**  
     reference selection overview, **B-4 to B-9**  
     selecting reference, **B-5**  
     tuning regulator, 13-10  
 Speed Ref 1, 11-18  
 Speed Ref 1 Frac, 11-18  
 Speed Ref 2, 11-18  
 Speed Ref 3, 11-18  
 Speed Ref 4, 11-18  
 Speed Ref 5, 11-19  
 Speed Ref 6, 11-19  
 Speed Ref 7, 11-19  
 speed regulation, 9-2  
 Speed Scale 1, 11-18  
 Speed Scale 7, 11-19  
 speed select table, 5-9  
 speed/torque selection, 11-26  
 speed/torque selection table, 5-10  
 Start Dwell Spd, 11-59, **B-5**  
 Start Dwell Time, 11-59, **B-5**  
 Start/Jog Mask, 11-40  
 Start/Stop Owner, 11-42  
 starting up your system, 6-7  
 state machine function, 10-8  
 Stator Resistnce, 11-50  
 stop  
     choosing, **B-6**  
     selecting coast, 11-14  
     selecting current limit, 11-14  
     selecting ramp, 11-14  
 Stop Dwell Time, 11-14

## T

terminal blocks  
     location for frames A1 – A4, 1-5  
     location for frames B – H, 1-6  
 terms, 1-3  
 Test Data 1, 11-31  
     check for fluxing time, 12-20  
     for calculated undervoltage, 12-19  
     for precharge status, 12-19  
 Test Data 2, 11-31  
     for math limit fault, 12-25 to 12-27  
     for parameter limit fault, 12-22  
 Test Select 1, 11-31  
     check for fluxing time, 12-20  
     for calculated undervoltage, 12-19  
     for precharge status, 12-19  
 Test Select 2, 11-32  
     for math limit fault, 12-25 to 12-27  
     for parameter limit fault, 12-22  
 through-put time, **B-38**  
 timer delay function, 10-5 to 10-8  
 torque  
     block overview, **B-24**  
     limits explained, **B-21**  
     reference overview, **B-19**  
     selecting, **B-22**  
 Torque Limit Sts, 11-30, **B-21**  
 torque options, 11-30  
 Torque Ref 1, 11-26, **B-22**  
 Total Inertia, 11-48, 13-10, 13-11  
 Trans Dgn Config, 11-51, 13-3  
 troubleshooting  
     encoderless, 12-29  
     Run Inhibit Sts, 11-14  
     start up, 12-27

## U

up/down counter, 10-14

## V

Vd Max, 11-51  
 voltage reflection reduction, 2-5  
 Vq Max, 11-51

## W

Warning Select 1, 8-7, 11-16, 12-18  
 Warning Select 2, 11-17, 12-5 to 12-6, 12-24  
 Warning Status 1, 11-71  
 Warning Status 2, 11-72  
 warnings, 12-2  
     Bus Cycle>5, 12-15  
     bus drop, 12-15  
     Bus Undervlt, 12-15  
     configuring, 11-16, 11-17, 12-4 to 12-6  
     External Flt In, 12-11

- Inv Overload, 12-9
- Inv Overtemp Pnd, 12-9
- InvOvld Pend, 12-9
- mA Input, 12-11
- Math Limit, 12-11
  - explained, 12-24
- Mtr Stall, 12-8
- MtrOvrlld Pend, 12-8
- MtrOvrlld Trp, 12-8
- Open Circuit, 12-15
- Param Limit, 12-11
  - explained, 12-22 to 12-24
- Prechg Time, 12-15
- Ridethru Time, 12-15
- SP 1 Timeout, 12-12
- SP 2 Timeout, 12-13
- SP 3 Timeout, 12-13
- SP 4 Timeout, 12-13
- SP 5 Timeout, 12-13
- SP 6 Timeout, 12-13
- SP Error, 12-13
- Spd Fdbk Loss, 12-11
  - viewing queue with HIM, 12-6
- Warning Select 2, 12-5 to 12-6
- wiring the power, 2-17

## **Z**

- Zero Speed Tol, 11-15

[www.rockwellautomation.com](http://www.rockwellautomation.com)

---

**Power, Control and Information Solutions Headquarters**

Americas: Rockwell Automation, 1201 South Second Street, Milwaukee, WI 53204-2496 USA, Tel: (1) 414.382.2000, Fax: (1) 414.382.4444

Europe/Middle East/Africa: Rockwell Automation, Vorstlaan/Boulevard du Souverain 36, 1170 Brussels, Belgium, Tel: (32) 2 663 0600, Fax: (32) 2 663 0640

Asia Pacific: Rockwell Automation, Level 14, Core F, Cyberport 3, 100 Cyberport Road, Hong Kong, Tel: (852) 2887 4788, Fax: (852) 2508 1846