

**SIEMENS**

Operating Instructions

# SIMOTICS

**S-1FT7 synchronous motors**

For SINAMICS S120

Edition

11/2016

[www.siemens.com](http://www.siemens.com)



# SIEMENS

## SIMOTICS

### Drive technology 1FT7 synchronous motors



#### Operating Instructions

Introduction	
Fundamental safety instructions	1
Description	2
Preparing for use	3
Assembly	4
Connection	5
Commissioning	6
Operation	7
Faults and their rectification	8
Maintenance	9
Decommissioning and disposal	10
Technical data	11
Appendix	A
Glossary	B

## Legal information

### Warning notice system

This manual contains notices you have to observe in order to ensure your personal safety, as well as to prevent damage to property. The notices referring to your personal safety are highlighted in the manual by a safety alert symbol, notices referring only to property damage have no safety alert symbol. These notices shown below are graded according to the degree of danger.

 <b>DANGER</b>
indicates that death or severe personal injury <b>will</b> result if proper precautions are not taken.
 <b>WARNING</b>
indicates that death or severe personal injury <b>may</b> result if proper precautions are not taken.
 <b>CAUTION</b>
indicates that minor personal injury can result if proper precautions are not taken.
<b>NOTICE</b>
indicates that property damage can result if proper precautions are not taken.

If more than one degree of danger is present, the warning notice representing the highest degree of danger will be used. A notice warning of injury to persons with a safety alert symbol may also include a warning relating to property damage.

### Qualified Personnel

The product/system described in this documentation may be operated only by **personnel qualified** for the specific task in accordance with the relevant documentation, in particular its warning notices and safety instructions. Qualified personnel are those who, based on their training and experience, are capable of identifying risks and avoiding potential hazards when working with these products/systems.

### Proper use of Siemens products

Note the following:

 <b>WARNING</b>
Siemens products may only be used for the applications described in the catalog and in the relevant technical documentation. If products and components from other manufacturers are used, these must be recommended or approved by Siemens. Proper transport, storage, installation, assembly, commissioning, operation and maintenance are required to ensure that the products operate safely and without any problems. The permissible ambient conditions must be complied with. The information in the relevant documentation must be observed.

### Trademarks

All names identified by ® are registered trademarks of Siemens AG. The remaining trademarks in this publication may be trademarks whose use by third parties for their own purposes could violate the rights of the owner.

### Disclaimer of Liability

We have reviewed the contents of this publication to ensure consistency with the hardware and software described. Since variance cannot be precluded entirely, we cannot guarantee full consistency. However, the information in this publication is reviewed regularly and any necessary corrections are included in subsequent editions.

# Introduction

## Keeping the documentation safe

This documentation should be kept in a location where it can be easily accessed and made available to the personnel responsible.

## Target group and utilization phases

### Target group

These Operating Instructions are intended for installation engineers, commissioners, machine operators, and service and maintenance personnel.

### Utilization phase

Planning and configuration phase, implementation phase, setup and commissioning phase, application phase, maintenance and service phase

## About the Operating Instructions

These Operating Instructions apply to the SIMOTICS S-1FT7 servo motor, referred to simply as "1FT7" in this document.

The Operating Instructions provide information about the components that enable the target group to install, set up, test, commission, operate, and troubleshoot the products and systems correctly and safely.

These Operating Instructions explain how to handle the 1FT7 from delivery to disposal.

You will find further information in the Configuration Manual for the 1FT7.

Before you start using the motor, you must read these Operating Instructions to ensure safe, problem-free operation and to maximize the service life.

Siemens strives continually to improve the quality of information provided in these Operating Instructions.

- If you find any mistakes or would like to offer suggestions about how this document could be improved, contact the Siemens Service Center.
- Always follow the safety instructions and notices in this Product Information.

The warning notice system is explained on the rear of the inside front.

## Text features

In addition to the notes that you must observe for your own personal safety as well as to avoid material damage, in this document you will find the following text features:

### Operating instructions

Operating instructions with the specified sequence are designated using the following symbols:



The arrow indicates the start of the operating instructions.

The individual handling steps are numbered.

1. Execute the operating instructions in the specified sequence.



The square indicates the end of the operating instruction.

Operating instructions without a specified sequence are identified using a bullet point:

- Execute the operating instructions.

### Enumerations

- Enumerations are identified by a bullet point without any additional symbols.
  - Enumerations at the second level are hyphenated.

### Notes

Notes are shown as follows:

---

#### Note

A Note is an important item of information about the product, handling of the product or the relevant section of the document. Notes provide you with help or further suggestions/ideas.

---

## More information

Information on the following topics is available under the link:

- Ordering documentation/overview of documentation
- Additional links to download documents
- Using documentation online (find and search in manuals/information)

More information (<https://support.industry.siemens.com/cs/de/en/view/108998034>)

Please send any questions about the technical documentation (e.g. suggestions for improvement, corrections) to the following e-mail address:

[docu.motioncontrol@siemens.com](mailto:docu.motioncontrol@siemens.com)

## My support

The following link provides information on how to create your own individual documentation based on Siemens content, and adapt it for your own machine documentation:

My support (<https://support.industry.siemens.com/My/de/en/documentation>)

---

### Note

If you want to use this function, you must first register.

Later, you can log on with your login data.

---

## Training

The following link provides information on SITRAIN - training from Siemens for products, systems and automation engineering solutions:

SITRAIN (<http://siemens.com/sitrain>)

## Technical Support

Country-specific telephone numbers for technical support are provided on the Internet under Contact:

Technical Support (<https://support.industry.siemens.com/sc/ww/en/sc/2090>)

## Internet address for products

Products (<http://www.siemens.com/motioncontrol>)

## Websites of third parties

This publication contains hyperlinks to websites of third parties. Siemens does not take any responsibility for the contents of these websites or adopt any of these websites or their contents as their own, because Siemens does not control the information on these websites and is also not responsible for the contents and information provided there. Use of these websites is at the risk of the person doing so.





# Table of contents

	<b>Introduction</b> .....	<b>5</b>
<b>1</b>	<b>Fundamental safety instructions</b> .....	<b>13</b>
1.1	General safety instructions .....	13
1.2	Handling electrostatic sensitive devices (ESD) .....	18
1.3	Industrial security .....	19
1.4	Residual risks of power drive systems.....	20
<b>2</b>	<b>Description</b> .....	<b>21</b>
2.1	Use for the intended purpose .....	21
2.2	Technical features and ambient conditions .....	22
2.2.1	Directives and standards .....	22
2.2.2	Technical features.....	23
2.2.3	Environmental conditions.....	25
2.2.4	Degree of protection .....	26
2.2.5	Noise emission.....	27
2.3	Derating factors.....	28
2.4	Rating plate data.....	29
2.5	Structure of the article number .....	30
2.6	Mounting and options.....	32
2.6.1	Safety symbols on the motor .....	32
2.6.2	Flange forms .....	33
2.6.3	Bearing version .....	33
2.6.4	Thermal motor protection.....	34
2.6.5	Encoder.....	36
2.6.5.1	Incremental encoders .....	36
2.6.5.2	Absolute encoder .....	38
2.6.6	Cooling.....	40
2.6.6.1	Natural cooling .....	40
2.6.6.2	Forced ventilation.....	40
2.6.6.3	Water cooling .....	42
2.6.7	Holding brake (option).....	45
2.6.7.1	Type of holding brake .....	45
2.6.7.2	Properties.....	45
2.6.8	Options.....	46
<b>3</b>	<b>Preparing for use</b> .....	<b>47</b>
3.1	Shipping and packaging .....	47
3.2	Transportation and storage.....	49
3.2.1	Transportation.....	49
3.2.2	Storage .....	53

<b>4</b>	<b>Assembly</b> .....	<b>55</b>
4.1	Safety instructions .....	55
4.2	Checklists prior to mounting.....	57
4.3	Mounting instructions .....	58
4.4	Mounting conditions .....	59
4.5	Pushing on the output elements .....	61
4.6	Vibration response .....	62
4.7	Mounting the water cooling .....	62
4.7.1	Materials for the cooling circuit .....	63
4.7.2	Mounting the water cooling .....	64
4.8	Mounting the sealing air connection .....	66
<b>5</b>	<b>Connection</b> .....	<b>69</b>
5.1	Safety instructions.....	69
5.2	Permissible line systems.....	70
5.3	Motor circuit diagram .....	70
5.4	System integration .....	71
5.4.1	Connection notes .....	71
5.4.1.1	Motor connection.....	71
5.4.1.2	Rotating the connector at the motor .....	73
5.4.1.3	Routing cables in a damp environment .....	76
5.4.2	Connecting to a converter .....	76
5.4.3	Connecting the forced ventilation.....	80
5.4.4	Connecting the holding brake .....	83
5.4.5	Line connection .....	85
5.4.5.1	Terminal box versions .....	85
5.4.5.2	Power connector version .....	87
5.4.6	Signal connection.....	88
5.4.6.1	Motors with DRIVE-CLiQ interface .....	88
5.4.6.2	Connecting the RJ45 DRIVE-CLiQ connector .....	90
5.4.6.3	Motors without a DRIVE-CLiQ interface .....	94
5.4.6.4	Signal connector version.....	95
5.4.6.5	Connecting the signal line for a motor with forced ventilation .....	96
<b>6</b>	<b>Commissioning</b> .....	<b>101</b>
6.1	Safety instructions.....	101
6.2	Checklists for commissioning.....	104
6.3	Commissioning procedure .....	107
6.4	Switching on and switching off.....	107
<b>7</b>	<b>Operation</b> .....	<b>109</b>
7.1	Safety instructions.....	109
7.2	Switching on and switching off.....	110
7.3	During operation.....	110
7.4	Stoppages .....	111

<b>8</b>	<b>Faults and their rectification.....</b>	<b>113</b>
<b>9</b>	<b>Maintenance .....</b>	<b>115</b>
9.1	Safety instructions.....	115
9.2	Inspection and maintenance.....	118
9.2.1	Maintenance and inspection intervals.....	118
9.2.2	Cleaning.....	119
9.2.3	Bearing replacement interval.....	120
9.3	Repair .....	120
<b>10</b>	<b>Decommissioning and disposal .....</b>	<b>121</b>
10.1	Safety instructions.....	121
10.2	Decommissioning.....	124
10.2.1	Preparing for dismantling.....	124
10.2.2	Disassembling the motor .....	124
10.3	Disposal .....	124
<b>11</b>	<b>Technical data .....</b>	<b>127</b>
<b>A</b>	<b>Appendix.....</b>	<b>129</b>
A.1	Certificate for the "PS Premium" painting system from ECOLAB.....	129
A.2	ECOLAB cleaning recommendation .....	132
<b>B</b>	<b>Glossary .....</b>	<b>133</b>
	<b>Index.....</b>	<b>135</b>



# Fundamental safety instructions

## 1.1 General safety instructions



 <b>DANGER</b>	
	<p><b>Danger to life due to live parts and other energy sources</b></p> <p>Death or serious injury can result when live parts are touched.</p> <ul style="list-style-type: none"> <li>• Only work on electrical devices when you are qualified for this job.</li> <li>• Always observe the country-specific safety rules.</li> </ul> <p>Generally, six steps apply when establishing safety:</p> <ol style="list-style-type: none"> <li>1. Prepare for shutdown and notify all those who will be affected by the procedure.</li> <li>2. Disconnect the machine from the supply.               <ul style="list-style-type: none"> <li>– Switch off the machine.</li> <li>– Wait until the discharge time specified on the warning labels has elapsed.</li> <li>– Check that it really is in a no-voltage condition, from phase conductor to phase conductor and phase conductor to protective conductor.</li> <li>– Check whether the existing auxiliary supply circuits are de-energized.</li> <li>– Ensure that the motors cannot move.</li> </ul> </li> <li>3. Identify all other dangerous energy sources, e.g. compressed air, hydraulic systems, or water.</li> <li>4. Isolate or neutralize all hazardous energy sources by closing switches, grounding or short-circuiting or closing valves, for example.</li> <li>5. Secure the energy sources against switching on again.</li> <li>6. Ensure that the correct machine is completely interlocked.</li> </ol> <p>After you have completed the work, restore the operational readiness in the inverse sequence.</p>



 <b>WARNING</b>	
	<p><b>Danger to life through a hazardous voltage when connecting an unsuitable power supply</b></p> <p>Touching live components can result in death or severe injury.</p> <ul style="list-style-type: none"> <li>• Only use power supplies that provide SELV (Safety Extra Low Voltage) or PELV- (Protective Extra Low Voltage) output voltages for all connections and terminals of the electronics modules.</li> </ul>



**! WARNING**

**Danger to life when live parts are touched on damaged motors/devices**

Improper handling of motors/devices can damage them.

For damaged motors/devices, hazardous voltages can be present at the enclosure or at exposed components.

- Ensure compliance with the limit values specified in the technical data during transport, storage and operation.
- Do not use any damaged motors/devices.



**! WARNING**

**Danger to life through electric shock due to unconnected cable shields**

Hazardous touch voltages can occur through capacitive cross-coupling due to unconnected cable shields.

- As a minimum, connect cable shields and the conductors of power cables that are not used (e.g. brake cores) at one end at the grounded housing potential.



**! WARNING**

**Danger to life due to electric shock when not grounded**

For missing or incorrectly implemented protective conductor connection for devices with protection class I, high voltages can be present at open, exposed parts, which when touched, can result in death or severe injury.

- Ground the device in compliance with the applicable regulations.



**! WARNING**

**Danger to life due to electric shock when opening plug connections in operation**

When opening plug connections in operation, arcs can result in severe injury or death.

- Only open plug connections when the equipment is in a no-voltage state, unless it has been explicitly stated that they can be opened in operation.

**NOTICE**

**Material damage due to loose power connections**

Insufficient tightening torques or vibrations can result in loose electrical connections. This can result in damage due to fire, device defects or malfunctions.

- Tighten all power connections with the specified tightening torques, e.g. line supply connection, motor connection, DC link connections.
- Check all power connections at regular intervals. This applies in particular after transport.

** WARNING****Danger to life through unexpected movement of machines when using mobile wireless devices or mobile phones**

Using mobile wireless devices or mobile phones with a transmit power > 1 W closer than approx. 2 m to the components may cause the devices to malfunction, influence the functional safety of machines therefore putting people at risk or causing material damage.

- Switch the wireless devices or mobile phones off in the immediate vicinity of the components.

** WARNING****Danger of an accident occurring due to missing or illegible warning labels**

Missing or illegible warning labels can result in accidents involving death or serious injury.

- Check that the warning labels are complete based on the documentation.
- Attach any missing warning labels to the components, in the national language if necessary.
- Replace illegible warning labels.

** WARNING****Danger to life when safety functions are inactive**

Safety functions that are inactive or that have not been adjusted accordingly can cause operational faults on machines that could lead to serious injury or death.

- Observe the information in the appropriate product documentation before commissioning.
- Carry out a safety inspection for functions relevant to safety on the entire system, including all safety-related components.
- Ensure that the safety functions used in your drives and automation tasks are adjusted and activated through appropriate parameterizing.
- Perform a function test.
- Only put your plant into live operation once you have guaranteed that the functions relevant to safety are running correctly.

**Note****Important safety notices for Safety Integrated functions**

If you want to use Safety Integrated functions, you must observe the safety notices in the Safety Integrated manuals.

 **WARNING**

**Danger to life from electromagnetic fields**

Electromagnetic fields (EMF) are generated by the operation of electrical power equipment, such as transformers, converters, or motors.

People with pacemakers or implants are at particular risk in the immediate vicinity of this equipment.

- If you have a heart pacemaker or implant, maintain the minimum distance specified in chapter "Correct usage" from such motors.

 **WARNING**

**Danger to life from permanent-magnet fields**

Even when switched off, electric motors with permanent magnets represent a potential risk for persons with heart pacemakers or implants if they are close to converters/motors.

- If you have a heart pacemaker or implant, maintain the minimum distance specified in chapter "Correct usage".
- When transporting or storing permanent-magnet motors always use the original packing materials with the warning labels attached.
- Clearly mark the storage locations with the appropriate warning labels.
- IATA regulations must be observed when transported by air.

 **WARNING**

**Risk of injury caused by moving parts or parts that are flung out**

Touching moving motor parts or drive output elements and loose motor parts that are flung out (e.g. feather keys) in operation can result in severe injury or death.

- Remove any loose parts or secure them so that they cannot be flung out.
- Do not touch any moving parts.
- Safeguard all moving parts using the appropriate safety guards.

 **WARNING**

**Danger to life due to fire if overheating occurs because of insufficient cooling**

Inadequate cooling can cause overheating resulting in death or severe injury as a result of smoke and fire. This can also result in increased failures and reduced service lives of motors.

- Comply with the specified coolant requirements for the motor.



 **WARNING**

**Danger to life due to fire as a result of overheating caused by incorrect operation**

When incorrectly operated and in the case of a fault, the motor can overheat resulting in fire and smoke. This can result in severe injury or death. Further, excessively high temperatures destroy motor components and result in increased failures as well as shorter service lives of motors.

- Operate the motor according to the relevant specifications.
- Only operate the motors in conjunction with effective temperature monitoring.
- Immediately switch off the motor if excessively high temperatures occur.

 **CAUTION**

**Risk of injury due to touching hot surfaces**

In operation, the motor can reach high temperatures, which can cause burns if touched.

- Mount the motor so that it is not accessible in operation.

Measures when maintenance is required:

- Allow the motor to cool down before starting any work.
- Use the appropriate personnel protection equipment, e.g. gloves.

## 1.2 Handling electrostatic sensitive devices (ESD)

Electrostatic sensitive devices (ESD) are individual components, integrated circuits, modules or devices that may be damaged by either electric fields or electrostatic discharge.



### NOTICE

#### Damage through electric fields or electrostatic discharge

Electric fields or electrostatic discharge can cause malfunctions through damaged individual components, integrated circuits, modules or devices.

- Only pack, store, transport and send electronic components, modules or devices in their original packaging or in other suitable materials, e.g. conductive foam rubber or aluminum foil.
- Only touch components, modules and devices when you are grounded by one of the following methods:
  - Wearing an ESD wrist strap
  - Wearing ESD shoes or ESD grounding straps in ESD areas with conductive flooring
- Only place electronic components, modules or devices on conductive surfaces (table with ESD surface, conductive ESD foam, ESD packaging, ESD transport container).

## 1.3 Industrial security

### Note

#### Industrial security

Siemens provides products and solutions with industrial security functions that support the secure operation of plants, systems, machines and networks.

In order to protect plants, systems, machines and networks against cyber threats, it is necessary to implement – and continuously maintain – a holistic, state-of-the-art industrial security concept. Siemens products and solutions only represent one component of such a concept.

The customer is responsible for preventing unauthorized access to its plants, systems, machines and networks. Systems, machines and components should only be connected to the enterprise network or the internet if and to the extent necessary and with appropriate security measures (e.g. use of firewalls and network segmentation) in place.

Additionally, Siemens' guidance on appropriate security measures should be taken into account. For more information about industrial security, please visit:

Industrial security (<http://www.siemens.com/industrialsecurity>).

Siemens' products and solutions undergo continuous development to make them more secure. Siemens strongly recommends to apply product updates as soon as available and to always use the latest product versions. Use of product versions that are no longer supported, and failure to apply latest updates may increase customer's exposure to cyber threats.

To stay informed about product updates, subscribe to the Siemens Industrial Security RSS Feed at:

Industrial security (<http://www.siemens.com/industrialsecurity>).

### WARNING

#### **Danger to life as a result of unsafe operating states resulting from software manipulation**

Software manipulations (e.g. viruses, trojans, malware or worms) can cause unsafe operating states in your system that may lead to death, serious injury, and property damage.

- Keep the software up to date.
- Incorporate the automation and drive components into a holistic, state-of-the-art industrial security concept for the installation or machine.
- Make sure that you include all installed products into the holistic industrial security concept.
- Protect files stored on exchangeable storage media from malicious software by with suitable protection measures, e.g. virus scanners.

## 1.4 Residual risks of power drive systems

When assessing the machine- or system-related risk in accordance with the respective local regulations (e.g., EC Machinery Directive), the machine manufacturer or system installer must take into account the following residual risks emanating from the control and drive components of a drive system:

1. Unintentional movements of driven machine or system components during commissioning, operation, maintenance, and repairs caused by, for example,
  - Hardware and/or software errors in the sensors, control system, actuators, and cables and connections
  - Response times of the control system and of the drive
  - Operation and/or environmental conditions outside the specification
  - Condensation/conductive contamination
  - Parameterization, programming, cabling, and installation errors
  - Use of wireless devices/mobile phones in the immediate vicinity of electronic components
  - External influences/damage
  - X-ray, ionizing radiation and cosmic radiation
2. Unusually high temperatures, including open flames, as well as emissions of light, noise, particles, gases, etc., can occur inside and outside the components under fault conditions caused by, for example:
  - Component failure
  - Software errors
  - Operation and/or environmental conditions outside the specification
  - External influences/damage
3. Hazardous shock voltages caused by, for example:
  - Component failure
  - Influence during electrostatic charging
  - Induction of voltages in moving motors
  - Operation and/or environmental conditions outside the specification
  - Condensation/conductive contamination
  - External influences/damage
4. Electrical, magnetic and electromagnetic fields generated in operation that can pose a risk to people with a pacemaker, implants or metal replacement joints, etc., if they are too close
5. Release of environmental pollutants or emissions as a result of improper operation of the system and/or failure to dispose of components safely and correctly
6. Influence of network-connected communication systems, e.g. ripple-control transmitters or data communication via the network

For more information about the residual risks of the drive system components, see the relevant sections in the technical user documentation.

## Description

### 2.1 Use for the intended purpose

<p> <b>WARNING</b></p> <p><b>Danger to life and material damage when incorrectly used</b></p> <p>If you do not use the motors correctly, there is a risk of death, severe injury and/or material damage.</p> <ul style="list-style-type: none"> <li>• Only use the motors for their intended purpose.</li> <li>• Make sure that the conditions at the location of use comply with all the rating plate data.</li> <li>• Make sure that the conditions at the location of use comply with the conditions specified in this documentation. When necessary, take into account deviations regarding approvals or country-specific regulations.</li> </ul>
--

<p> <b>WARNING</b></p> <p><b>Danger to life caused by magnetic and electrical fields for carriers of active implants</b></p> <p>Electric motors endanger people with active implants, for example heart pacemakers, who come close to the motors.</p> <ul style="list-style-type: none"> <li>• If you are an affected person, maintain a minimum distance of 300 mm from the motors.</li> </ul>
--

If you wish to use special versions and design variants whose specifications vary from the motors described in this document, then contact your local Siemens office.

If you have any questions regarding the intended usage, please contact your local Siemens office.

The 1FT7 motor is intended for industrial or commercial plants.

The motor is designed for operation in sheltered areas under normal climatic conditions, such as those found on shop floors.

The motor is only approved for operation through a converter.

Any other application of the motor is considered to be incorrect usage.

Compliance with all of the specifications in the Operating Instructions is part of correct usage.

Observe the data on the rating plate (type plate).

#### Applications

- High-performance machine tools
- Machines with high requirements in terms of dynamic response and precision

## 2.2 Technical features and ambient conditions

### 2.2.1 Directives and standards

#### Standards that are complied with

SIMOTICS S, SIMOTICS M, SIMOTICS L, SIMOTICS T, SIMOTICS A motors - subsequently called the "SIMOTICS motor series " - comply with the following standards:

- EN 60034-1 - Rotating electrical machines – Dimensioning and operating behavior
- EN 60204-1 - Safety of machinery – Electrical equipment of machines; general requirements

Where applicable, the SIMOTICS motor series are in conformance with the following parts of IEC / EN 60034:

Feature	Standard
Degree of protection	IEC / EN 60034-5
Cooling <sup>1)</sup>	IEC / EN 60034-6
Type of construction	IEC / EN 60034-7
Connection designations	IEC / EN 60034-8
Noise levels <sup>1)</sup>	IEC / EN 60034-9
Temperature monitoring	IEC / EN 60034-11
Vibration severity levels <sup>1)</sup>	IEC / EN 60034-14

<sup>1)</sup> Standard component, e.g. cannot be applied to built-in motors

#### Relevant directives

The following directives are relevant for SIMOTICS motors.

##### European Low-Voltage Directive

SIMOTICS motors comply with the Low-Voltage Directive 2014/35/EU.

##### European Machinery Directive

SIMOTICS motors do not fall within the area of validity covered by the Machinery Directive.

However, the use of the products in a typical machine application has been fully assessed for compliance with the main regulations in this directive concerning health and safety.

##### European EMC Directive

SIMOTICS motors do not fall within the area of validity covered by the EMC Directive. The products are not considered as devices in the sense of the directive.





### Eurasian conformity

SIMOTICS motors comply with the requirements of the customs union Russia/Belarus/Kazakhstan (EAC).



### China Compulsory Certification

SIMOTICS motors do not fall within the area of validity covered by the China Compulsory Certification (CCC).

CCC product certification

(<https://support.industry.siemens.com/cs/document/93012735/allgemeine-produktzulassung-ccc?lc=de-VW&pnid=13347>)



### Underwriters Laboratories

SIMOTICS motors are generally in compliance with UL and cUL as components of motor applications, and are appropriately listed.

Specifically developed motors and functions are the exceptions in this case. Here, it is important that you carefully observe the contents of the quotation and that there is a cUL mark on the rating plate!

### Quality systems

Siemens AG employs a quality management system that meets the requirements of ISO 9001 and ISO 14001.

Certificates for SIMOTICS motors can be downloaded from the Internet at the following link:

Certificates for SIMOTICS motors

(<https://support.industry.siemens.com/cs/products?dtp=Certificate&mf=ps&pnid=13347&lc=de-VW>)

## 2.2.2 Technical features

Table 2- 1 Technical features

Motor type	Permanent-magnet synchronous motor
Magnet material	Rare-earth magnetic material
Cooling	<ul style="list-style-type: none"> <li>• Natural cooling</li> <li>• Forced ventilation</li> <li>• Water cooling</li> </ul>
Insulation of the stator winding according to EN 60034-1 (IEC 60034-1)	Temperature class 155 (F) for a winding overtemperature of $\Delta T = 100$ K at an ambient temperature of $+40^\circ$ C (naturally cooled, forced ventilation) or a coolant temperature of $+30^\circ$ C (water-cooled)
Operating range	$-15^\circ$ to $+40^\circ$ C, derating at higher temperatures

Description

2.2 Technical features and ambient conditions

Installation altitude for naturally-cooled and force-ventilated motors according to EN 60034-1 (IEC 60034-1)	≤ 1000 m above sea level, otherwise power derating At installation altitudes of 2000 m above mean sea level or higher, a reduction of the voltage load of the motors is also required (see ambient conditions)
Type of construction according to EN 60034-7 (IEC 60034-7)	IM B5 (IM V1, IM V3)
Degree of protection according to EN60034-5 (IEC 60034-5)	IP64, IP65 and IP67 optional, IP54 motors with forced ventilation, IP55
Flange form	Classic flange (1FT6/1FK7 compatible), optional recessed flange
Temperature monitoring according to EN 60034-11 (IEC 60034-11)	Temperature sensor in the stator winding
Paint finish	Pearl dark gray (similar to RAL 9023)
Drive shaft end according to DIN 748-3 (IEC 60072-1)	Smooth shaft, shaft with feather key
Radial eccentricity, concentricity, and axial eccentricity according to DIN 42955 (IEC 60072-1)	Tolerance N (normal) or R
Vibration severity grade according to EN 60034-14 (IEC 60034-14)	Grade A is observed up to rated speed, optional grade R
Sound pressure level according to DIN EN ISO 1680 Tolerance + 3 dB(A)	Natural cooling: 1FT703□ to 1FT706□: 65 dB(A) 1FT708□ to 1FT713□: 70 dB(A) 1FT7117: ≤ 80 dB(A) Forced ventilation: 1FT706□ to 1FT713□: 73 dB(A) 1FT7117: ≤ 80 dB(A) Water cooling: 1FT706□: 65 dB(A) 1FT708□ to 1FT710□: 70 dB(A)
Integrated encoder system for motors without DRIVE-CLiQ interface	<ul style="list-style-type: none"> <li>IC2048S/R <sup>1)</sup> incremental encoder sin/cos 1 Vpp, 2048 S/R <sup>1)</sup> with C and D tracks</li> <li>Absolute encoder 2048 S/R <sup>1)</sup>, 4096 revolutions, multiturn, with EnDat interface</li> </ul>
Integrated encoder system for motors with DRIVE-CLiQ interface	<ul style="list-style-type: none"> <li>IC22DQ incremental encoder 22-bit (resolution 4194304, in the encoder 2048 S/R <sup>1)</sup>) + commutation position 11-bit</li> <li>AM22DQ absolute encoder 22-bit singleturn (resolution 4194304, in the encoder 2048 S/R <sup>1)</sup>) + 12-bit multiturn (traversing range 4096 revolutions)</li> <li>AS24DQI absolute encoder 24-bit singleturn (resolution 16777220, in the encoder 2048 S/R <sup>1)</sup>)</li> <li>AM24DQI absolute encoder 24-bit singleturn (resolution 16777220, in the encoder 2048 S/R <sup>1)</sup>) + 12-bit multiturn (traversing range 4096 revolutions)</li> </ul>
Connection	Signal and power connectors (sizes 1, 1.5 and 3; alternative for connector size 3 terminal box possible)
Holding brake	Optional integrated holding brake (free of backlash, 24 V)

<sup>1)</sup> S/R = Signals/revolution



### 2.2.3 Environmental conditions

You can classify the environmental conditions for stationary use at weather-protected locations according to standard DIN IEC 60721-3-3. The environmental effects and their limit values are defined in various classes in this standard.

With the exception of "Condensation" and "Low air pressure" environmental parameters, you can assign SIMOTICS S servomotors to climatic class 3K4. Condensation is not permissible.

The following temperature ranges apply for natural-cooled and forced-ventilation motors.

Table 2- 2 Environmental conditions are based on climate class 3K4

Environmental parameter		Unit	Value
a)	Low air temperature	°C	- 15
b)	High air temperature	°C	+ 40
c)	Low relative humidity	%	5
d)	High relative humidity	%	95
e)	Low absolute humidity	g/m <sup>3</sup>	1
f)	High absolute humidity	g/m <sup>3</sup>	29
g)	Rate of temperature change <sup>1)</sup>	°C/min	0.5
h)	Low air pressure <sup>4)</sup>	kPa	89
i)	High air pressure <sup>2)</sup>	kPa	106
j)	Solar radiation	W/m <sup>2</sup>	700
k)	Thermal radiation	-	-
l)	Air movement <sup>3)</sup>	m/s	1.0
m)	Condensation	-	Not permissible
n)	Wind-driven precipitation (rain, snow, hail, etc.)	-	-
o)	Water (other than rain)	-	See protection class
p)	Formation of ice	-	-

<sup>1)</sup> Averaged over a period of 5 min

<sup>2)</sup> Conditions in mines are not considered.

<sup>3)</sup> A cooling system based on natural convection can be disturbed by unforeseen air movements.

<sup>4)</sup> The limit value of 89 kPa covers applications at altitudes up to 1000 m.

#### Note

##### Installation instructions

SIMOTICS S motors are not suitable for operation

- In salt-laden or aggressive atmospheres
- Outdoors

You find additional data on the environmental conditions, such as ambient temperatures or conditions for transport and storage of the motors, in the relevant chapters of this documentation.

**2.2.4 Degree of protection**

1FT7 motors can be supplied with degree of protection IP64, IP65, or IP67 according to EN 60034-5 (IEC 60034-5).

1FT7 motors with forced ventilation have degree of protection IP54 or IP55 according to EN 60034-5 (IEC 60034-5).

Additionally protect the motors from lubricants that contain oil, are creep-capable, and/or are corrosive by means of suitable covers.

**Sealing of the motor shaft**

Table 2- 3 Motor shaft sealing

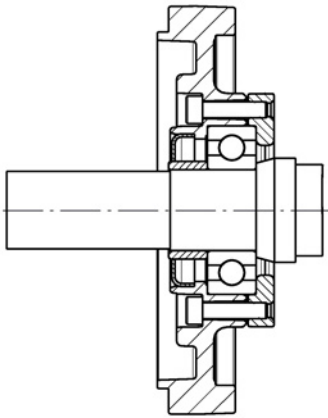
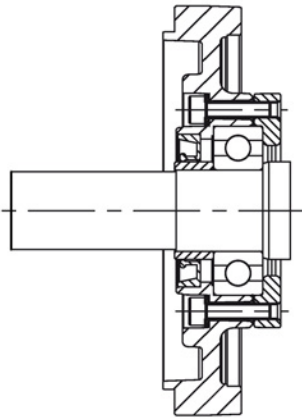
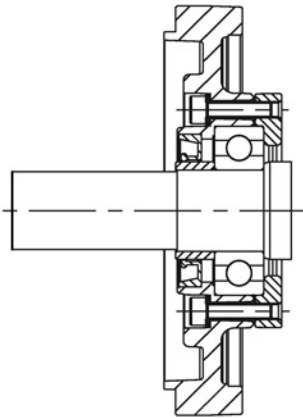
IP64	IP65	IP67
		
<p>Labyrinth seal It is not permissible that there is any moisture in the area around the shaft and the flange. Note: For degree of protection IP64 it is not permissible that liquid collects in the flange.</p>	<p>Radial shaft sealing ring without annular spring Sealing of the shaft exit against splashwater or coolant. Dry running of the radial shaft sealing ring is permissible. Lifetime approx. 25000 h (nominal value). With degree of protection IP65, it is not permissible for liquid to collect in the flange.</p>	<p>Radial shaft sealing ring For gearbox mounting (for gearboxes that are not sealed) to seal against oil. The sealing lip must be adequately cooled and lubricated by the gearbox oil in order to guarantee reliable function. Lifetime approx. 10000 h (nominal value). If a radial shaft sealing ring runs dry, then this has a strong negative impact on the functionality and the lifetime.</p>

## 2.2.5 Noise emission

When operated in the speed range 0 to rated speed, 1FT7 motors can reach the following measuring-surface sound pressure level  $L_p(A)$ :

Table 2- 4 Sound pressure level

Cooling method	Shaft height	Measuring-surface sound pressure level $L_p(A)$
Naturally cooled	1FT703 to 1FT706 1FT708 to 1FT713 1FT7117	65 dB(A) + 3 dB tolerance 70 dB(A) + 3 dB tolerance $\leq 80$ dB(A)
Forced-ventilated	1FT706 to 1FT713 1FT7117	73 dB(A) + 3 dB tolerance $\leq 80$ dB(A)
Water-cooled	1FT706 1FT708 to 1FT710	65 dB(A) + 3 dB tolerance 70 dB(A) + 3 dB tolerance

The motors are approved for a wide range of installation and operating conditions. These conditions, such as rigid or vibration-isolated foundation design, influence noise emission, sometimes significantly.

## 2.3 Derating factors

Under conditions other than those specified above (ambient temperature > 40° C or installation altitude > 1000 m above sea level), the permissible torques/powers are shown in the following table.

Ambient temperatures and installation altitudes are rounded off to 5° C or 500 m respectively.

Table 2- 5 Derating of the thermally permissible power as a function of the installation altitude and ambient temperature

Installation altitude above sea level [m]	Ambient temperature in °C				
	< 30	30 - 40	45	50	55
1000	1.07	1.00	0.96	0.92	0.87
1500	1.04	0.97	0.93	0.89	0.84
2000	1.00	0.94	0.90	0.86	0.82
2500	0.96	0.90	0.86	0.83	0.78
3000	0.92	0.86	0.82	0.79	0.75
3500	0.88	0.82	0.79	0.75	0.71
4000	0.82	0.77	0.74	0.71	0.67

The factors refer to the static torque  $M_0$ . You shift the S1 characteristic curve in parallel.

At installation altitudes of 2000 m above sea level or higher, the voltage stress on the motors must be reduced accordingly based on the "Factors for reducing the maximum DC-link voltage" table (reciprocal values from EN 60664-1 Table A. 2).

Table 2- 6 Factors for reducing the maximum DC-link voltage

Installation altitude up to [m] above mean sea level	Factor
2000	1
3000	0.877
4000	0.775
5000	0.656
6000	0.588
7000	0.513
8000	0.444

As the DC-link voltage is reduced, the converter output voltage also decreases. This reduces the operating range in the M-n diagram.

The M-n diagrams are contained in the associated Configuration Manual.

Operation in a vacuum is not permissible because of the low dielectric strength and poor heat dissipation.

## 2.4 Rating plate data

The rating plate contains the technical data applicable to the motor. A second rating plate is provided loose with the motor when it is delivered.

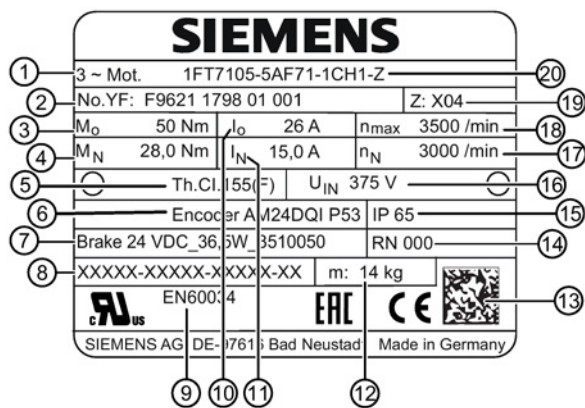

Figure 2-1 Rating plate 1FT7

Table 2- 7 Description of the rating plate data

Position	Description / Technical data
1	Motor type: Synchronous motors
2	ID No., serial number
3	Static torque $M_o$ (100 K) [Nm]
4	Rated torque $M_N$ [Nm]
5	Temperature class
6	Code, encoder type
7	Holding brake data: Typical, voltage, power consumption
8	Field for customer data for the option Y84 (max. 20 characters, any distribution)
9	Standard on which the motor is based
10	Stall current $I_o$ [A]
11	Rated current $I_N$ [A]
12	Motor weight $m$ [kg]
13	2D code
14	Motor version
15	Degree of protection
16	Induced voltage at rated speed $U_{IN}$ [V]
17	Rated speed $n_N$ [rpm]
18	Maximum speed $n_{max}$ [rpm]
19	Options of the motor (up to 2 options can be represented, no marking for further options)
20	Motor type/order number

## 2.5 Structure of the article number

The article number comprises a combination of digits and letters. It is divided into three hyphenated blocks.

Possible combinations are contained in Catalog D 21.4

(<https://intranet.for.siemens.com/org/i-dt-mc/en/motion-control/support/marketing-materials/catalogs/d-21-4-sinamics-s120-simotics/Pages/d-21-4.aspx#>).

Note that not every theoretical combination is available.

Description		Position of the article number																					
		1	2	3	4	5	6	7	-	8	9	10	11	12	-	13	14	15	16	-	Z		
<b>SIMOTICS M-1FT7 synchronous built-in motors</b>		1	F	D	7																		
<b>Frame size / shaft height</b>		SH 36				0	3																
		SH 48				0	4																
		SH 63				0	6																
		SH 80				0	8																
		SH 100				1	0																
						1	1																
		SH 132				1	3																
<b>Overall length</b>								2															
								4															
								6															
								7															
								8															
<b>Feature</b>	Core type									1													
	Compact									5													
	High Dynamic									7													
	Special version									9													
<b>Cooling</b>	Natural cooling									A													
	Water cooling									W													
	Forced ventilation									S													
<b>Rated speeds</b>	(3 AC 380 V ... 480 V)				1,500 rpm						B												
					2,500 rpm						C												
					3,000 rpm						F												
					4,500 rpm						H												
					6,000 rpm						K												
					Special version						Z												
<b>DC-link voltage (600 V ... 720 V)</b>											7												
<b>Flange-mounted version</b>	recessed				with DRIVE-CLiQ interface						0												
					without DRIVE-CLiQ interface						5												
	classic (compatible with 1FT6/1FK7) <sup>1)</sup>				with DRIVE-CLiQ interface						1												
					without DRIVE-CLiQ interface						4												



Description	Position of the article number																			
	1	2	3	4	5	6	7	-	8	9	10	11	12	-	13	14	15	16	-	Z
	Special paint finish for the "Worldwide" climate group																			K23
	Special paint finish for "Worldwide" climate group, primed and other paint finish																			K23+X
	Primed (unpainted)																			K24
	Paint finish															jet black, matt		RAL 9005	X01	
																cream		RAL 9001	X02	
																reseda green		RAL 6011	X03	
																pebble grey		RAL 7032	X04	
																sky blue		RAL 5015	X05	
																light ivory		RAL 1015	X06	
																white aluminum		RAL 9006	X08	
																anthracite		RAL 7016	X09	

- 1) Only to shaft height 100
- 2) Connector size 3 not rotatable. A terminal box can be selected as alternative only for connector size 3.
- 3) For motors with forced ventilation IP54 or IP55
- 4) More detailed information can be found at Configuration Manual (<https://support.industry.siemens.com/cs/document/109482538/simotics-s-1ft7-synchronous-motors-for-sinamics-s120?dti=0&dl=en&nid=13350&lc=de-WW>)

## 2.6 Mounting and options

### 2.6.1 Safety symbols on the motor

The following warning and information labels are attached to the motor.

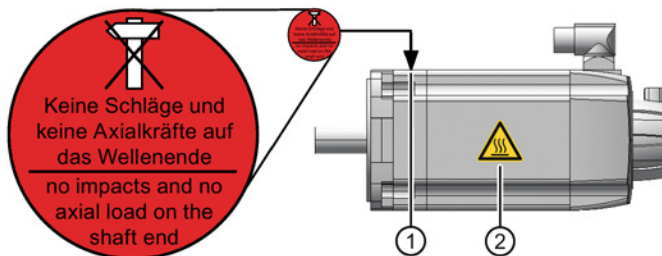

- 1 "No impacts or axial forces on the shaft extension" warning sign.
- 2 "Hot surfaces" warning sign. The warning sign is on one side of the housing.



## 2.6.2 Flange forms

Table 2- 8 Flange forms

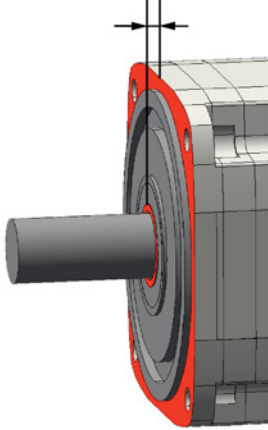
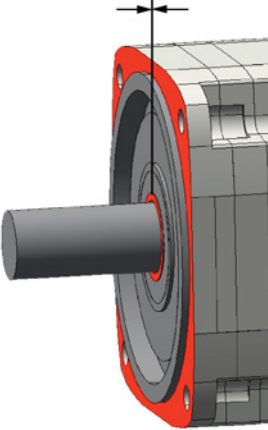
Designation	Representation	Description
Recessed flange		Flange recessed In the article number: 1FT7□□□-□□□□ <b>0</b> -□□□□ or 1FT7□□□-□□□□ <b>5</b> -□□□□
Classic flange		Flange compatible with 1FT6/1FK7 motors In the article number: 1FT7□□□-□□□□ <b>1</b> -□□□□ or 1FT7□□□-□□□□ <b>4</b> -□□□□

## 2.6.3 Bearing version

The motors have the following bearings:

- Deep-groove ball bearings with life grease lubrication
- Location bearings at the DE

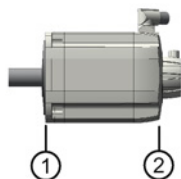

- 1 DE or drive end
- 2 NDE or non-drive end

## 2.6.4 Thermal motor protection

A temperature-dependent resistor is integrated as temperature sensor to monitor the motor temperature.

- Starting in 2017, 1FT7 motors with integrated DRIVE-CLiQ interface are generally changed to the Pt1000. The marking is made with the revision number of the motors. The order number does not need to be changed.
- Motors without integrated DRIVE-CLiQ interface are converted with changed order number to the new Pt1000 temperature sensor. In conjunction with the following encoders without DRIVE-CLiQ, the 12th position of the order number must be changed accordingly.

1FT7 motors without DRIVE-CLiQ interface:	Old order number with KTY 84-130	New order number with Pt1000
With recessed flange and IC2048S/R encoder	1FT7□□□-□□□□0-□N□□	1FT7□□□-□□□□5-□N□□
With recessed flange and AM2048S/R encoder	1FT7□□□-□□□□0-□M□□	1FT7□□□-□□□□5-□M□□
Flange-compatible to 1FT6/1FK7 with IC2048S/R encoder	1FT7□□□-□□□□1-□N□□	1FT7□□□-□□□□4-□N□□
Flange-compatible to 1FT6/1FK7 with AM2048S/R encoder	1FT7□□□-□□□□1-□M□□	1FT7□□□-□□□□4-□M□□

Only versions with Pt1000 temperature sensor can be ordered for 1FT7, shaft height 132.

Flange-compatible to 1FT6 with IC2048S/R encoder	-	1FT713□-□□□□4-□N□□
Flange-compatible to 1FT6 with AM2048S/R encoder	-	1FT713□-□□□□4-□M□□

Table 2- 9 Features and technical data

Type	KTY 84-130	Pt1000
Resistance when cold (20° C)	Approx. 580 Ω	Approx. 1090 Ω
Resistance when hot (100° C)	Approx. 1000 Ω	Approx. 1390 Ω
Connection	Via signal cable	via signal cable
Response temperature	Prewarning < 150° C Alarm/trip at max. 170° C ±5° C	Prewarning < 150° C Alarm/trip at max. 170° C ±5° C

The following figure shows the resistance characteristic as a function of the temperature for KTY 84-130 and Pt1000 temperature sensors.

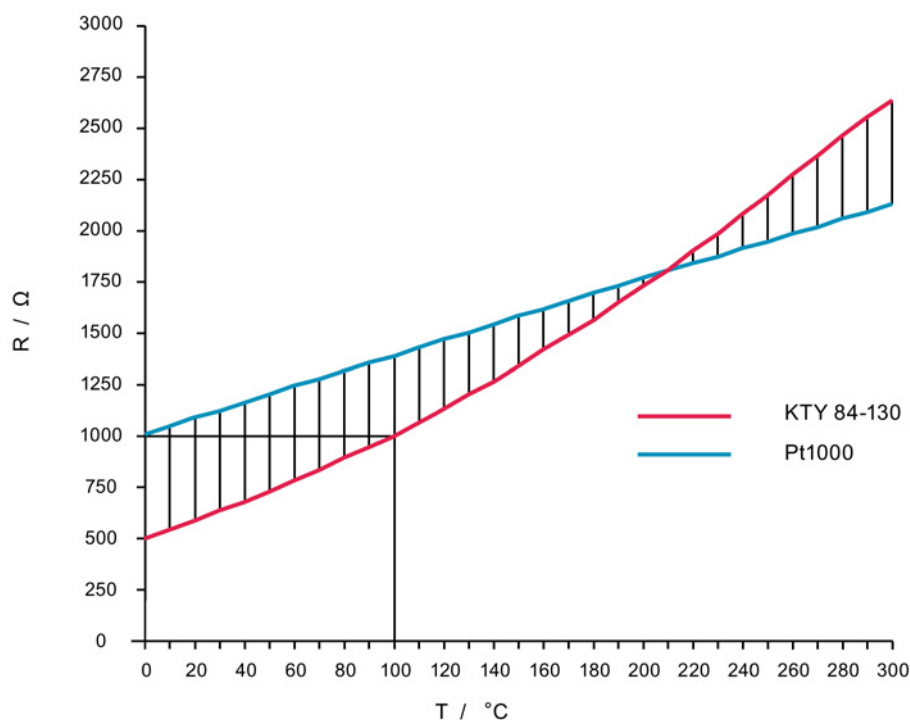

Figure 2-2 Comparison of KTY 84-130 and Pt1000 temperature sensors

The winding temperature is evaluated in the converter. When a fault occurs, an appropriate message is output at the converter. When the motor temperature increases, a message "Alarm motor overtemperature" is output. The message can be evaluated externally.

If this message is ignored, the converter shuts down with the appropriate fault message after a preset time period or when the motor limiting temperature or the shutdown temperature is exceeded.

The integrated temperature sensor protects the synchronous motors only to a certain extent against overloads:

Shaft heights 36 and 48: up to  $2 \cdot I_{0(60K)}$  and speed  $\neq 0$   
 from SH 63: up to  $3 \cdot I_{0(60K)}$  and speed  $\neq 0$

#### NOTICE

##### **Destruction of the motor for a thermal critical load**

For load applications that are critical from a thermal perspective, e.g. overload when the motor is stationary or an overload of  $M_{max}$  longer than 4 s, adequate protection is no longer available.

- Activate the "Thermal motor model i<sup>2</sup>t monitoring" function in the converter.

The temperature sensor is part of a SELV circuit, which can be destroyed if high voltage is applied. The temperature sensor is designed so that the DIN/EN requirement for "protective separation" is fulfilled.

## 2.6.5 Encoder

### Encoder systems with DRIVE-CLiQ interface

Motors with a DRIVE-CLiQ encoder interface are provided for the SINAMICS S110/S120 converter system. Signal transmission to the converter is performed digitally. They have an electronic rating plate that simplifies commissioning and diagnostics. The motor and encoder system are automatically identified and all motor parameters are automatically set, see SINAMICS Equipment Manual.

#### NOTICE

##### Damage to components that are sensitive to electrostatic discharge

The contacts of the DRIVE-CLiQ interface have direct contact to components that can be damaged/destroyed by electrostatic discharge (ESDs).

- Do not touch the connections directly even with tools. They could be charged electrostatically.

### Encoder systems without a DRIVE-CLiQ interface

For motors without an integrated DRIVE-CLiQ interface, the analog encoder signal is first converted to a digital signal in the drive system. For these motors, the encoder signals for SINAMICS S110 / S120 must be transferred via Sensor Modules.

#### NOTICE

##### Damage to components that are sensitive to electrostatic discharge

The contacts of the connector plug have direct contact to components that can be damaged/destroyed by electrostatic discharge (ESDs).

- Do not touch the connections directly even with tools that could be electrostatically charged.

### 2.6.5.1 Incremental encoders

#### Description

This encoder senses relative movements and does not supply absolute position information. In combination with evaluation logic, a zero point can be determined via the integrated reference mark, which can be used in turn to calculate the absolute position.

The encoder outputs sine and cosine signals. These can be interpolated using evaluation logic (usually 2048x) and the direction of rotation can be determined. In the version with a DRIVE-CLiQ interface, this evaluation logic is already integrated in the encoder.

### Function and technical data

- Angular measuring system for the commutation
- Speed actual value sensing
- Indirect incremental measuring system for the position control loop
- One zero pulse (reference mark) per revolution

Table 2- 10 Technical data for incremental encoders

Encoders	Code	Operating voltage	Max. current consumption	A-B track: Resolution incremental (sin/cos periods per revolution)	C-D track: Rotor/commutation position (sin/cos periods per revolution)	Angle error
<b>without DRIVE-CLiQ interface</b>						
Incremental encoder sin/cos 1 Vpp, 2048 S/R with C and D tracks	IC2048S/R	5 V ± 5%	140 mA	2048 S/R (1 Vpp)	1 S/R (1 Vpp)	± 40 "
<b>with DRIVE-CLiQ interface<sup>1)</sup></b>						
Incremental encoder 22 bits (resolution 4,194,304, internal 2048 S/R) + commutation position 11 bits	IC22DQ	24 V	180 mA	4,194,304 (=22 bits)	2048 (=11 bits)	± 40 "

Mech. speed limit for all incremental encoders: 12000 rpm

1) The "singleturn absolute value encoders" can also be used as incremental encoders on the SINAMICS drive system. For new applications, the new DQI encoder generation must be used. The IC22DQ is superseded by the AS24DQI.

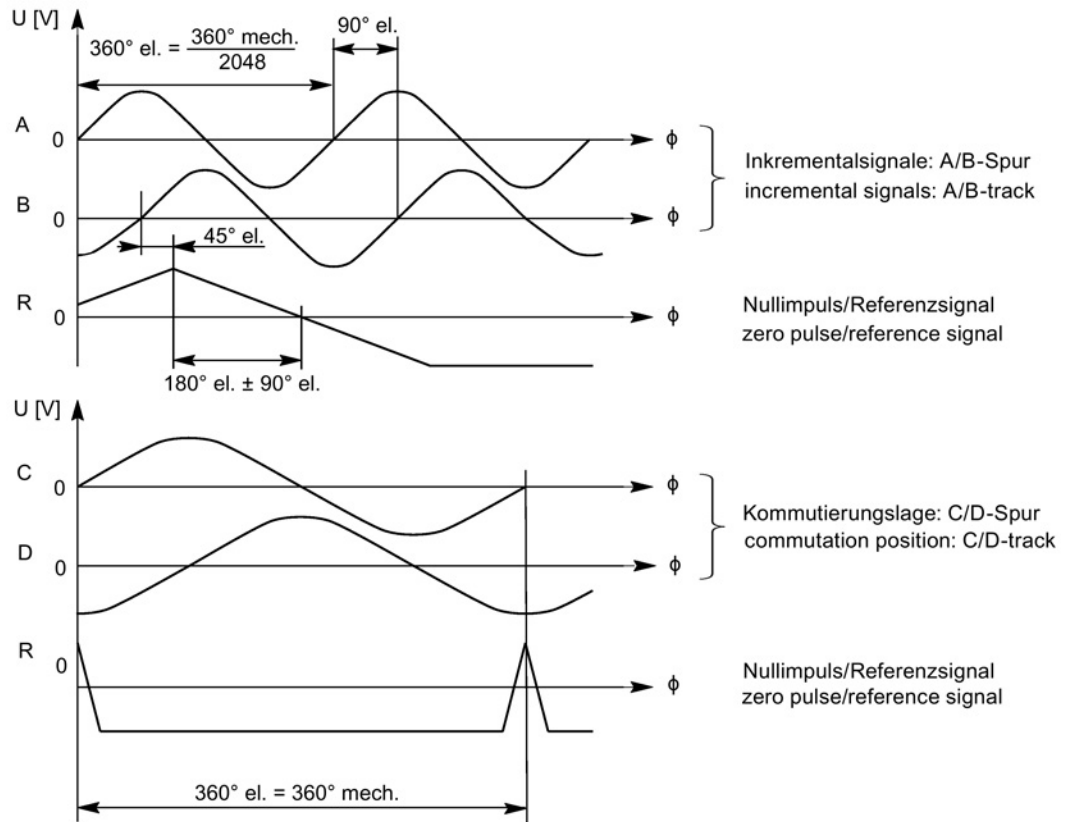

Figure 2-3 Signal sequence and assignment for encoder IC2048S/R without a DRIVE-CLiQ interface, for a positive direction of rotation

For encoder connection, pin assignment, and cables, refer to the section titled "Connection system"

### 2.6.5.2 Absolute encoder

#### Description of multiturn absolute value encoders

This encoder outputs an absolute angular position between 0° and 360° in the specified resolution. An internal measuring gearbox enables the encoder to differentiate between 4096 revolutions. With a ball screw, for example, the encoder can determine the absolute position of the slide over a long distance.

#### Description: Single-turn absolute value encoder

This encoder outputs an absolute angular position between 0° and 360° in the specified resolution. Unlike the multiturn absolute value encoder, the singleturn absolute value encoder has no measuring gearbox and can therefore only supply the position value within one revolution. The singleturn absolute value encoder does not have a traversing range.

## Function and technical data

- Angular measuring system for the commutation
- Speed actual value acquisition
- Indirect measuring system for absolute position determination within a revolution
- Indirect measuring system for determining the absolute position within a traversing range of 4096 revolutions
- For multiturn encoders: Indirect measuring system for absolute position determination within a traversing range
- Indirect incremental measuring system for position control loop

Table 2- 11 Technical data, absolute value encoder without DRIVE-CLiQ interface

Description	Code	Operating voltage	Maximum power consumption	Absolute resolution (singletum)	Traversing range (multiturn)	A-B track: Incremental resolution (sin/cos periods per revolution)	Angular error
<b>Serial absolute position interface: EnDat 2.1</b>							
Absolute value encoder 2048 S/R, (4096 revolutions, multi-turn, with EnDat interface)	AM2048S/R	5 V ± 5 %	200 mA	8192 (= 13 bits)	4096 (= 12 bits)	2048 S/R (1 Vpp)	± 40"

Table 2- 12 Technical data, absolute value encoder with DRIVE-CLiQ interface

Description	Code	Operating voltage	Maximum power consumption	Absolute resolution (single-turn)	Traversing range (multiturn)	Angle error
<b>Serial absolute position interface: DRIVE-CLiQ</b>						
Absolute value encoder, singleturn, 24-bit	AS24DQI	24 V	110 mA	16,777,216 (=24 bits)	-	± 40"
Absolute value encoder 24-bit + 12-bit multiturn	AM24DQI	24 V	110 mA	16,777,216 (=24 bits)	4096 (= 12 bits)	± 40"
Absolute value encoder 22 bits + 12 bits multi-turn	AM22DQ <sup>1)</sup>	24 V		4,194,304 (= 22 bits)	4096 (= 12 bits)	± 40"

Mech. speed limit for all absolute value encoders: 12,000 rpm

1) Use the new DQI encoder generation for new applications The AM22DQ is superseded by the AM24DQI absolute value encoder.

For the signal sequence and assignment of the A/B track, see Chapter "Incremental encoders (Page 36)" Fig. "Signal sequence and assignment for encoder IC2048S/R without DRIVE-CLiQ interface for a positive direction of rotation."

2.6 Mounting and options

2.6.6 Cooling

2.6.6.1 Natural cooling

On naturally cooled motors, the heat loss is dissipated through thermal conduction, radiation and natural convection.

Some of the heat loss is dissipated through the mounting surface of the motor. From large motors, heat is dissipated via the base frame (steel plate).

Note the specifications on thermally non-insulated mounting and on thermally insulated mounting in Chapter Mounting conditions (Page 59)

---

**Note**

To ensure enough heat is dissipated, a minimum clearance to adjacent components of 100 mm must be kept free on three side surfaces.

---

- Mount the motor in such a way that sufficient clearance is provided for heat dissipation.

The motor ratings apply in an ambient temperature of 40 °C (104 °F). If the ambient temperature exceeds 40 °C (104 °F), you must adjust the torque and power of the motor accordingly.

- Adjust the torque or the power of the motor at the converter based on the table in Chapter "Environmental conditions (Page 25)."  
Follow the operating instructions of the converter.

2.6.6.2 Forced ventilation

This cooling method is achieved using a separate ventilation unit with a fan that is driven independently of the motor.

 <b>WARNING</b>
<b>Explosion hazard</b> Operating the fan in an environment with inflammable, chemically corrosive, electrically conductive, or explosive dust or gases can cause explosions and result in death or serious injury. <ul style="list-style-type: none"><li>• Operate the motor with forced ventilation only in an environment that is free of inflammable, chemically corrosive, electrically conductive, or explosive dust or gases.</li></ul>



**⚠ WARNING****Danger to life due to objects being sucked in.**

For example, hair, neckties, loose objects can be sucked into the air intake and cause death or serious injury.

- Take measures to prevent objects from being sucked in, e.g.
  - Wear a head covering or hair net,
  - Remove any neckties or similar,
  - Keep the air intake area free.

**Note**

Ensure that the motor is only operated when the external fan is running.

Operate the fan only with normal ambient air.

Table 2- 13 Air flow direction of the forced ventilation

Motor	Air flow direction
For 1FT706□ to 1FT710□	NDE --> DE
For 1FT713□	DE --> NDE

Deposits of contaminated air can impair the heat dissipation of the motor or block the cooling duct and overheat the motor.

- Position the motor so that the cooling air can freely flow in and out.
- Make sure that no heated discharged air is drawn in.
- Maintain the minimum clearance between the air intake and discharge openings and adjacent components (see the "Minimum clearance" figure).
- To remove the fan cover and connect the signal connector when the motor is installed, maintain a minimum clearance of 125 mm.

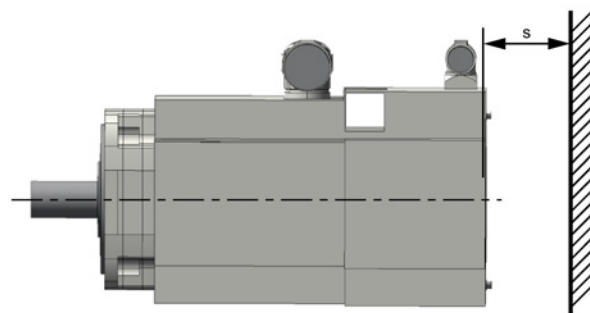

- s
- A minimum clearance of 30 mm applies to SH 63 and SH 80.
  - A minimum clearance of 50 mm applies to SH 100.
  - A minimum clearance of 60 mm applies to SH 132.

Figure 2-4 Minimum clearance s

2.6.6.3 Water cooling

The motor can only be operated in a closed cooling-water circuit with a cooling unit.

The motor is connected to the cooling circuit by means of two female threads at the rear of the motor. The intake and discharge lines can be connected to either.

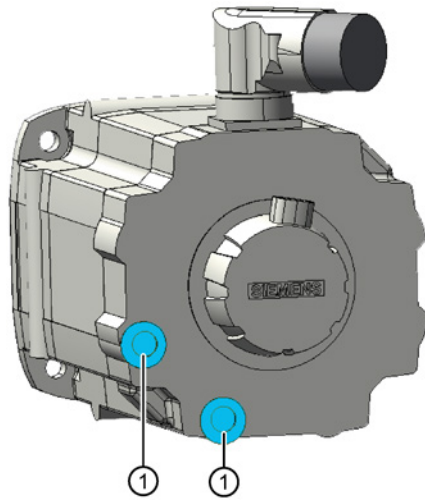

1 Ports for the water cooling

Notes on setting up the cooling circuit

- Use pipes and fittings made of brass, stainless steel, or plastic. Galvanized pipes and fittings are not permitted.

**Note**

If you use different materials in the cooling circuit, pay attention to the electrochemical series. That is the reason why zinc must not be used in cooling water circuits.

- Install a filter (100 µm) against contamination in the flow line of the cooling circuit.
- If necessary, limit the flow rate with a flow restrictor. Install the flow restrictor downstream of the motor. It must not be installed directly in front of the inlet because it may cause cavitation.

Table 2- 14 Technical data relating to water cooling

Cooling water connection		G 1/4"
Cooling water flow	1FT706x	3 l/min
	1FT708x	4 l/min
	1FT710x	5 l/min
Max. pressure at inlet		Max. 6 bar
Pressure drop between inlet and outlet	1FT706x	< 0.3 bar for minimum cooling water flow
	1FT708x	< 0.3 bar for minimum cooling water flow
	1FT710x	< 0.25 bar for minimum cooling water flow

Minimum cooling water inlet temperature	$T_{\text{cooling}} > T_{\text{ambient}} - 5 \text{ K}$
Maximum cooling water inlet temperature, without derating	$\leq 30^\circ \text{ C}$ , higher values will cause derating

**Note****Avoid condensation**

Cooling water temperatures that are lower than the ambient temperature tend to result in increased water condensation. The difference between the cooling water inlet temperature and the ambient temperature must therefore not exceed a maximum of 5 K (Kelvin).

- Select the cooling water inlet temperature such that condensation does not form on the surface of the motor:  $T_{\text{cooling}} > T_{\text{ambient}} - 5 \text{ K}$ .
- Additionally shut off the coolant supply if the motor is to remain at a standstill for a long time.

Lowering the inlet temperature of the cooling water by 5 K relative to the ambient temperature permits a relative humidity up to approx. 75% for the temperatures in the "Derating factors" table below. Condensation does not then occur. Deviations from these values are provided by the Mollier diagram.

- If the relative humidity is higher than 75%, you will have to raise the inlet temperature of the cooling water further.
- If the actual relative humidity is lower than 75%, you can lower the inlet temperature of the cooling water further.

Table 2- 15 Derating factors

Cooling water inlet temperature	$\leq 30^\circ \text{ C}$	$35^\circ \text{ C}$	$40^\circ \text{ C}$	$45^\circ \text{ C}$
Derating factor	1.00	0.97	0.95	0.92

The factors refer to the static torque  $M_0$ . You shift the S1 characteristic curve in parallel.

As the coolant, use only water that meets the "water specification for coolant".

**Note**

If possible, use deionized water with reduced conductivity (5 ... 10  $\mu\text{S/cm}$ ) as the coolant.

2.6 Mounting and options

Other coolants (e.g. cooling-lubricating medium, water-oil mixtures with 10% oil and higher) can reduce the power of the motor.

Table 2- 16 Water specifications for coolant

	Quality of the water used as coolant for motors with aluminum, stainless steel tubes + cast iron or steel jacket
Chloride ions	< 40 ppm, can be achieved by adding deionized water.
Sulfate ions	< 50 ppm
Nitrate ions	< 50 ppm
pH value	6 ... 9 (for aluminum 6 ... 8)
Electrical conductivity	< 500 µS/cm
Total hardness	< 170 ppm
Dissolved solids	< 340 ppm
Size of entrained particles	< 100 µm
Corrosion protection	0.2 to 0.25% inhibitor, Nalco TRAC100 (previously 0GE056)
Anti-freeze protection	When required, 20 - 30% Antifrogen N (made by Clariant)

The values specified for the water as a coolant are the requirements for a closed cooling circuit. Not all of the specified concentrations will occur in the water at the same time. Ask your water utility for the values if necessary.

**Note**

Inhibitor is not required if an Antifrogen N concentration > 20% is ensured.

Derating is not required for antifreeze protection components < 30%.

If there is a risk of frost, preventive measures must be taken for operation, storage, and transportation.

- Replenish antifreeze for operation (see Table "Quality of the coolant").

**Note**

- Avoid mixing different antifreeze products.
- Use and dose the antifreeze according to the manufacturer's specifications.

## 2.6.7 Holding brake (option)

### 2.6.7.1 Type of holding brake

The holding brake is implemented as a permanent-magnet brake.

The magnetic field of the permanent magnets exerts a pulling force on the brake armature disk. This means that in the no-current condition, the brake is closed and the motor shaft is held.

When 24 V DC rated voltage is applied to the brake, the current-carrying coil produces an opposing field. This neutralizes the force of the permanent magnets and the brake opens without any residual torque.

The permanent magnet brake has a torsionally stiff connection to the motor rotor. Therefore the brake has no play.

<b>NOTICE</b>
<p><b>Damage to the motor due to axial forces on the shaft extension</b></p> <p>Axial forces on the shaft extension can damage motors with an integrated permanent-magnet holding brake.</p> <ul style="list-style-type: none"> <li>• Avoid axial forces on the shaft extension.</li> </ul>

### 2.6.7.2 Properties

- The holding brake is used to clamp the motor shaft when the motor is at a standstill. The holding brake is **not** a working brake for braking the rotating motor.

 <b>WARNING</b>
<p><b>Danger to life caused by unintended movements of the machine or installation</b></p> <p>If you ignore the permissible number of braking operations, the braking effectiveness of the holding brake can be irreversibly reduced. This can cause unintended movements of the machine or installation resulting in death or serious injury.</p> <ul style="list-style-type: none"> <li>• Observe the permissible number of braking operations.</li> <li>• Operate the motor only in conjunction with an intact brake.</li> </ul>

- Restricted Emergency Stop operation is permissible. You can perform up to 2000 braking operations with three times the rotor moment of inertia as an external moment of inertia from a speed of 3000 rpm, without the brake being subject to an inadmissible amount of wear.

- Do not exceed the maximum operating energy per emergency braking.
- The rated voltage of the holding brake is 24 VDC +/- 10%. Voltages outside this tolerance range can cause faults.

**NOTICE**

**Premature wear of the motor holding brake when operated outside its permissible voltage range**

Operating the motor holding brake outside its permissible voltage range at the motor connection will damage the brake.

- Ensure that the motor holding brake is only operated within its permissible voltage range.

**NOTICE**

**Faulty brake function due to inadmissible wear**

Inadmissible wear means that the braking function can no longer be guaranteed.

- Comply with the emergency stop features stated above.
- Avoid repeated brief acceleration of the motor against a holding brake that is still closed. Consider the operating times of the brakes and the relays in the drive control and enable.

**Note**

Subsequent conversion of motors with or without a holding brake is not possible.

The technical data for the holding brake is contained in the Configuration Manual of the motor.

### 2.6.8 Options

The descriptions of the options are contained in the associated Configuration Manual of the motor

**See also**

Configuration Manual

<https://support.industry.siemens.com/cs/document/109482538/simotics-s-1ft7-synchronous-motors-for-sinamics-s120?dti=0&dl=en&pnid=13350&lc=de-WW>





## Preparing for use

### 3.1 Shipping and packaging

The drive systems are put together on an individual basis.

Please pay attention to the handling notes on the packaging in which the motor is delivered.

Table 3- 1 Handling notes and their meaning

Symbol	Meaning	Symbol	Meaning
	Fragile (ISO 7000, No. 0621)		Keep dry (ISO 7000, No. 0626)
	Top (ISO 7000, No. 0623)		Do not stack (ISO 7000, No. 2402)

#### Checking the delivery for completeness

- Upon receipt of the delivery, check immediately whether the items delivered match the accompanying documents.

---

#### Note

Siemens will not accept any claims for missing or incorrect items submitted at a later date.

---

- Report any visible transportation damage to the delivery company immediately.
- Report any visible defects or missing items to the competent Siemens office immediately.

The delivery includes a second rating plate (type plate). The second rating plate can be used to post the motor data additionally in the vicinity of the motor.

The additional rating plate (type plate) is

- in the terminal box for motors with terminal boxes
- in the safety data sheet for motors with power connectors.

The supplementary sheets with the safety instructions are part of the scope of supply.

---

#### Note

Keep the sheets with the safety instructions in an accessible location at all times.

---





## 3.2 Transportation and storage

### 3.2.1 Transportation

---

#### Note

Comply with the local national regulations for the transportation of motors.

---

- Use suitable load suspension devices when transporting and installing the motor.
- Transport the motor carefully.

#### Lifting and transporting the motor using slings up to SH 80

Up to a shaft height of 80 mm, you can lift and transport the motor with slings.

 <b>WARNING</b>
<b>Incorrectly dimensioned or incorrectly used lifting slings</b>
If lifting slings are incorrectly dimensioned or incorrectly used, the motor can fall and cause death, severe injury and/or damage to property.
<ul style="list-style-type: none"><li>• Only use lifting slings that are suitable for the weight of the motor.</li><li>• Attach the lifting slings as shown in the figure "Lifting and transporting the motor using slings".</li></ul>

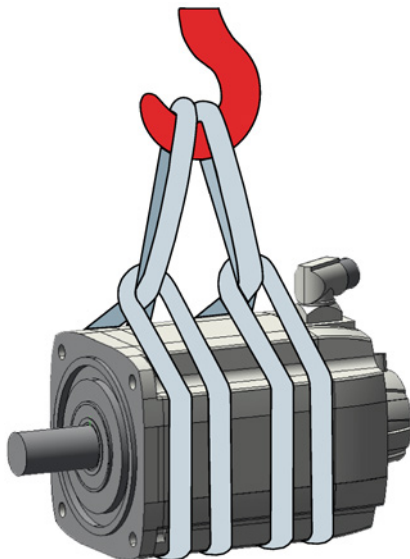

Figure 3-1 Transporting with slings

**Lifting and transporting with lifting eyes as of SH 80**

For motors as of a shaft height of 80 mm, use lifting eyes and a beam to lift and transport the motor.

The threads for the lifting eyes are provided for 1FT708□, 1FT710□ and 1FT7117 motors in M8 and for 1FT713□ motors in M10.

**⚠ WARNING**

**Incorrect or unused lifting points**

Due to incorrect or unused lifting points, the motor can fall and cause death, severe injury and/or damage to property.

- Lift and transport larger motors
  - only at the eyebolts in the end shields
  - on the NDE, only at the lifting eyes on the external fan
- Completely screw in the lifting eyes and tighten by hand (approx. 8 Nm).
- Do not use bent or damaged lifting eyes.
- Use only lifting eyes with laminated fiber washers.
- Loads applied transversely to the plane of the lifting eyes are not permitted.

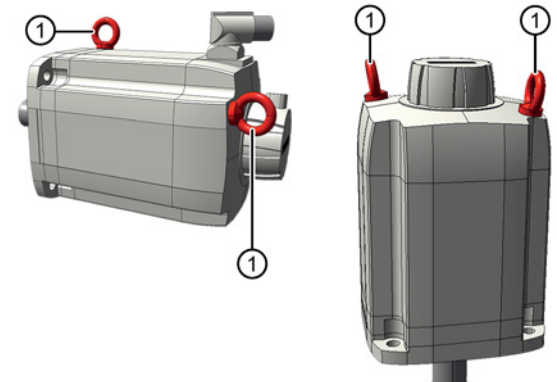
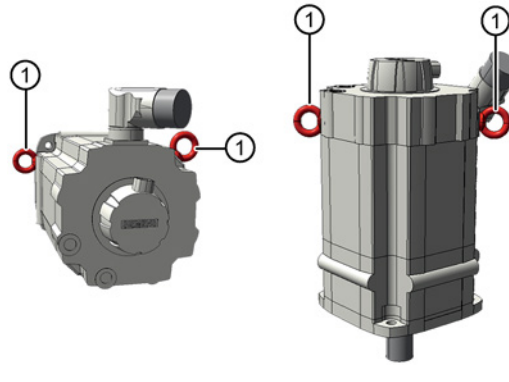
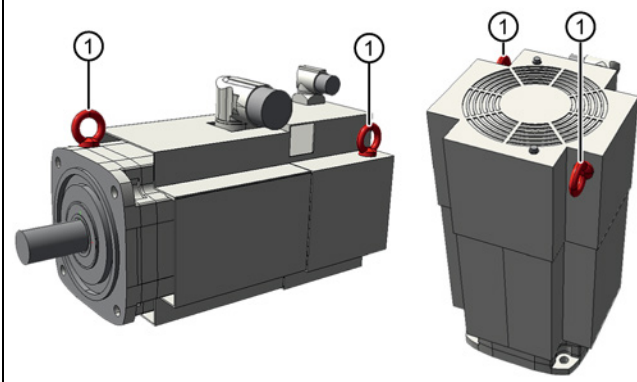
	
1FT7 with natural cooling (shaft heights 80 - 100)	1FT7 with water cooling
	
1FT7 with forced ventilation (shaft height 63 - 100)	
① Lifting eyes	

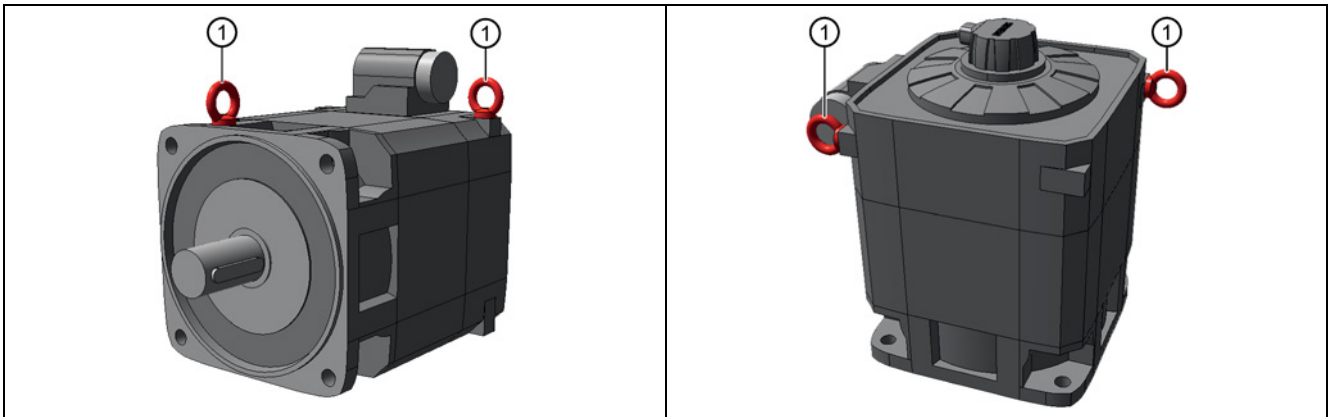

1FT7 with natural cooling (shaft height 132)

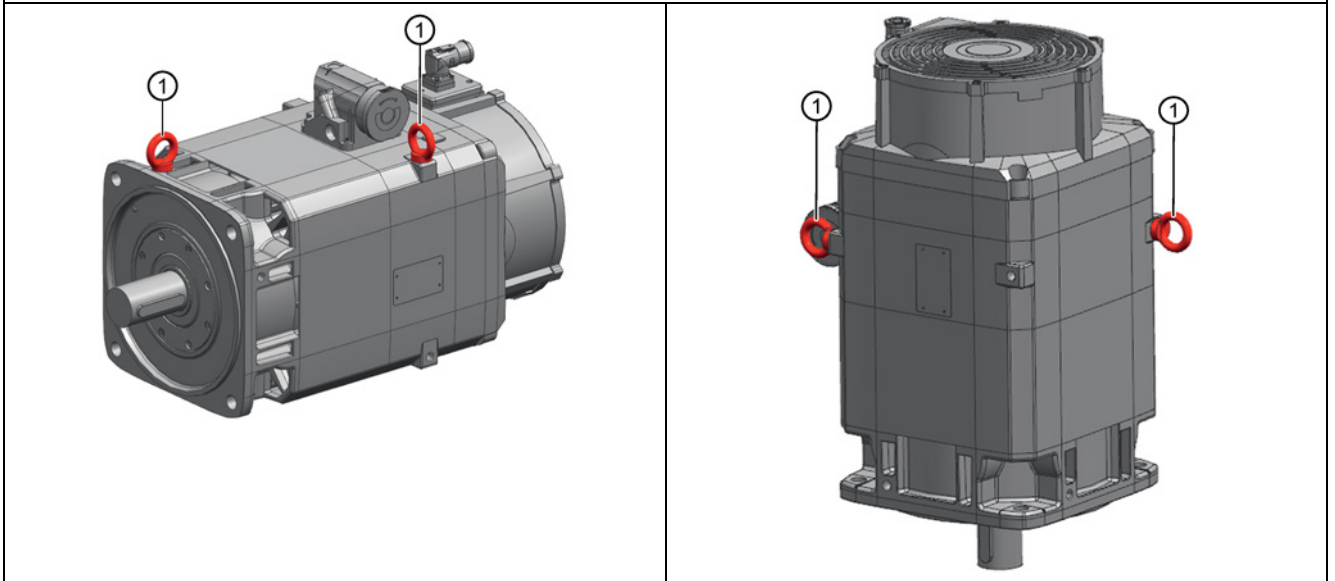

1FT7 with forced ventilation (shaft height 132)

① Lifting eyes

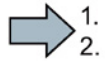

**Procedure**

1. Screw in the lifting eyes at appropriate locations for the orientation of the motor during transportation.
2. Hook the beam into the lifting eyes.

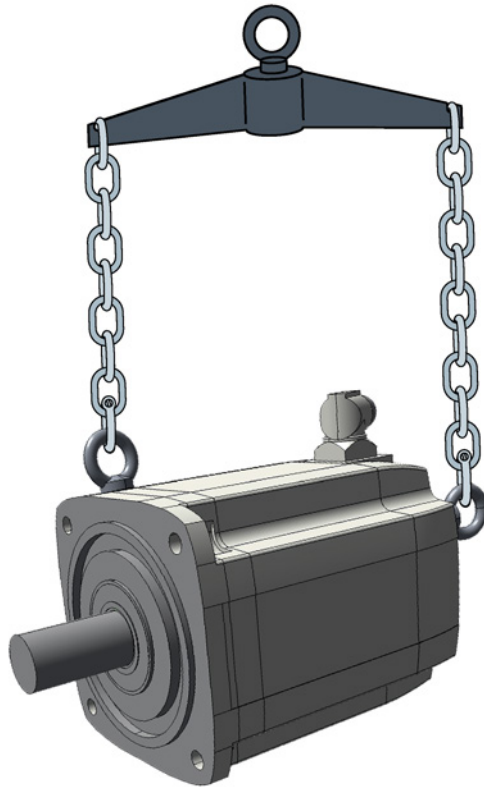



Figure 3-2 Transportation with beam



**Setting down the motor**

 <b>WARNING</b>
<b>Danger of severe injury due to unintentional movements of the motor</b>
If the motor is not secured after being set down, unintentional movements of the motor can cause serious injury.
<ul style="list-style-type: none"><li>• After the motor has been set down, secure it in position.</li><li>• Do not release the lifting devices until the motor has been secured in position.</li></ul>



**Procedure**

1. Set the motor down on a hard, level surface.
2. Secure the motor against unintentional movements.



## 3.2.2 Storage

---

### Note

If possible, store the motor in its original packaging.

---

<b>NOTICE</b>
---------------

<b>Frost damage to water-cooled motors</b>
--

Water-cooled motors can be damaged by frost
---

- |  |
|--|
| <ul style="list-style-type: none"><li>• Remove the liquid coolant before storage and blow out the cooling ducts with compressed air.</li></ul> |
|--|

Preserve the free shaft ends, sealing elements, and flange surfaces with a protective coating.

<b>NOTICE</b>
---------------

<b>Seizure damage to bearings</b>
-----------------------------------

If the motors are stored incorrectly, bearing seizure damage can occur, e.g. brinelling, as a result of vibration.
--

- |   |
|---|
| <ul style="list-style-type: none"><li>• Comply with the storage conditions.</li></ul> |
|---|

### Storage conditions

Please observe the warning instructions on the packaging and labels.

Store the motor in a dry, dust-free, and vibration-free indoor storage facility.

Adhere to the following values:

- $v_{rms} < 0.2$  mm/s
- Max. temperatures: -15 °C to 55 °C
- Mean relative humidity < 75%

## Long-term storage

---

### Note

#### Storage time up to two years

The storage time affects the properties of the roller bearing grease.

- Store the motor for up to two years at -15 °C to 55 °C.
-

---

**Note**

In the case of storage in transit over 6 months, special arrangements must be made for preservation.

- Contact Technical Support.
- 

If you store the motor for longer than six months, the storage facility must meet the following conditions:

- The motor must be protected against extreme weather conditions.
- The facility air must be free of corrosive gases.
- The facility must be free of vibrations ( $v_{\text{eff}} < 0.2 \text{ mm/s}$ )
- According to EN 60034-1, the temperature must be  $-15^\circ \text{ C}$  to  $55^\circ \text{ C}$ .
- The relative humidity of the air must be lower than 60%.

Check the correct state of the motor every six months.

- Check the motor for any damage.
- Perform any necessary maintenance work.
- Check the state of the dehydrating agent and replace when necessary.
- Record the preservation work so that all preservation coating can be removed prior to the commissioning.

**Condensation**

The following ambient conditions encourage the formation of condensation:

- Large fluctuations of the ambient temperature
- Direct sunshine
- High air humidity during storage.

Avoid these ambient conditions.

Use a dehydrating agent in the packaging.

# Assembly

## 4.1 Safety instructions

### WARNING

#### **Danger to life as a result of incorrect transport and/or lifting of the motor**

Incorrectly transporting and/or lifting the motor can result in death, severe injury, and/or damage to property. For instance, the motor can fall.

- Lifting devices, ground conveyors, and load suspension equipment must comply with requirements.
- The maximum capacity of the lifting equipment and the load suspension device must correspond to the weight of the motor (see the rating plate).
- Do not attach any additional loads to the lifting equipment.
- To hoist the motor, use suitable cable-guidance or spreading equipment, particularly if the motor is equipped with built-on assemblies.
- The motor must not be lifted or transported by means of the power connector or signal connector.
- Do not stand in the slewing range of hoisting gear or under suspended loads.

### WARNING

#### **Danger to life from permanent magnet fields**

Even when switched off, electric motors with permanent magnets pose a potential risk for persons with heart pacemakers or implants if they are close to inverters/motors.

- If you have a heart pacemaker or implant, keep a minimum distance of 20 cm.
- When transporting or storing permanent magnet motors always use the original packing materials with the warning labels attached.
- Clearly mark the storage locations with the appropriate warning labels.
- IATA regulations must be observed when transporting by air.

### WARNING

#### **Danger to life due to freely rotating parts**

Contact with rotating parts can cause death or severe injury.

- Do not touch any rotating parts.
- Mount a cover cap or protective shroud over freely rotating parts.

 **WARNING**

**Danger to life due to unpredictable movements of the system**

The system can perform unpredictable movements under load that can cause death or severe injury.

- De-energize the system before starting work.
- Disconnect all loads from the system.
- Secure the system against accidental reclosure.

**NOTICE**

**Damage to shaft sealing rings caused by solvent**

If shaft sealing rings come into contact with solvents when preservation coating is removed, the shaft sealing rings can be damaged.

- Avoid contact between solvents and shaft sealing rings.

**NOTICE**

**Thermal damage to temperature-sensitive parts**

Some parts of the electrical motor enclosure can reach temperatures that exceed 100 °C. If temperature-sensitive parts, for instance electric cables or electronic components, come into contact with hot surfaces then these parts can be damaged.

- Ensure that no temperature-sensitive parts come into contact with hot surfaces.



## 4.2 Checklists prior to mounting

**Note**

**Required checks**

The checklists below do not purport to be complete. It may be necessary to perform additional checks and tests in accordance with the situation specific to the particular installation site.

Assemble the motor as described in the following chapters of the operating instructions.

Thoroughly familiarize yourself with the safety instructions and observe the checklists below before starting any work.

Table 4- 1 Checklist (1) - general checks

Check	OK
Are all of the necessary components of the configured drive line-up available, correctly dimensioned, installed and connected?	
Are the environmental conditions in the permissible range?	

Table 4- 2 Checklist (2) - checks regarding the mechanical system

Check	OK
Is the motor free of visible damage?	
Have the mounting surfaces (e.g. flange, shaft) on the customer machine and on the motor been cleaned?	
Are the mounting surfaces free of corrosion?	
Do the mounting dimensions (e.g. shaft diameter, shaft length, true run) on the customer machine meet the specification?	

## 4.3 Mounting instructions

### NOTICE

#### Damage to the motor due to runout on the shaft extension

Runout and thrust on the shaft extension of the motor can damage the motor.

- Mount the motor without runout and thrust on the shaft extension.

### Note

Observe the technical data on the rating plate on the motor enclosure.

- Observe the data on the rating plate, as well as the warning and information plates on the motor.
- Check the permissible ambient conditions (e.g. temperature, installation altitude) at the installation location.  
Their use is prohibited in hazardous zones.
- Thoroughly clean the shaft extension of corrosion protection. Use commercially available solvents.
- Ensure sufficient dissipation of heat. See Chapter "Mounting conditions (Page 59)"
- If the motor is installed vertically with the end of the shaft facing up, ensure that no liquid can enter the upper bearing.
- If fluid media come into contact with the DE flange, a special flange seal is required.

The motor is sealed via the machined flat contact surface of the centering edge on the DE flange, e.g. with an O ring. The sealing is on the circumference. Sealing at the flange contact surface of the motor is not envisaged.

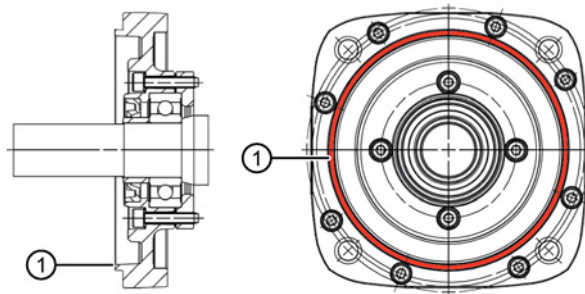

Figure 4-1 Position of the sealing surface on the face of the centering edge

- Ensure that the flange is in even contact with the mounting surface.
- Use hexagon socket head cap screws with a property class of at least 8.8.
- When tightening the fastening bolts avoid any uneven stressing.
- Observe the tightening torques of the fastening bolts of the motor flange. See the "Tightening torques for fastening bolts" table.
- After installation, remove the lifting eyes or tighten them.

### Tightening torques for fastening bolts

The general tolerance for the tightening torque is 10%. The tightening torque is based on a friction coefficient of  $\mu = 0.14$ .

Motor	Screw DIN 7984	Washer ISO 7092 [mm]	Tightening torque for screws (not for electrical connections)
1FT703	M6	6 (d2 = 11)	8 Nm
1FT704	M6	6 (d2 = 11)	8 Nm
1FT706	M8	8 (d2 = 15)	20 Nm
1FT708	M10	10 (d2 = 18)	35 Nm
1FT710 1FT7117	M12	12 (d2 = 20)	60 Nm
1FT713	M16	16 (d2 = 28)	165 Nm

"Tightening torques for fastening bolts" table.

The mounting tools to be used are a torque wrench or pneumatic or impact power screwdriver with automatic switch-off.

## 4.4 Mounting conditions

On naturally cooled motors, the thermal losses are dissipated by thermal conduction, radiation, and natural convection.

Some of the thermal losses are dissipated through the mounting surface of the motor. On large motors, heat is dissipated via the base frame (steel plate).

Note the specifications on thermally non-insulated mounting and on thermally insulated mounting.

---

### Note

To ensure adequate heat dissipation, a minimum clearance to adjacent components of 100 mm must be maintained on three sides of the motor.

---

- Mount the motor in such a way that sufficient clearance is provided for heat dissipation.

The motor ratings apply in an ambient temperature of 40° C (104° F). If the ambient temperature exceeds 40° C (104° F), you must adjust the torque and power of the motor accordingly.

- Adjust the torque or the power of the motor at the converter based on the table in Chapter "Derating factors (Page 28)."  
Follow the Operating Instructions of the converter.

Fasten the base frame to the mounting surface thermally conductively.

**Non-thermally insulated mounting**

For the specified motor data, the following mounting conditions apply:

Table 4- 3 Non-thermally insulated mounting conditions

Shaft height	Steel plate, width x height x thickness [mm]	Mounting surface[m <sup>2</sup> ]	Base plate W x D [mm]	Surface of the base plate [m <sup>2</sup> ]
36 and 48	120 x 100 x 40	0.012	150 x 350	0.053
63 to 100	450 x 370 x 30	0.17	500 x 1500	0.75
132	550 x 380 x 35	0.21	550 x 2500	1.38

For larger mounting surfaces, the heat dissipation conditions improve.

**Thermally insulated mounting without additionally mounted components**

For non-ventilated and forced-ventilated motors, the static motor torque must be reduced by between 5% and 15%. We recommend configuring the static torque of the motor using the  $M_{0(60K)}$  values. As the speed increases, the reduction factor rises, see Fig. "Effect of the mounting conditions on the S1 characteristic curve".

**Thermally insulated mounting with additionally mounted components**

- Holding brake (integrated in the motor): No additional torque reduction required
- Gearbox: The torque has to be reduced. See figure "Effect of the mounting conditions on the S1 characteristic curve"

**Basic effect of thermally non-insulated/insulated mounting without and with gearbox**

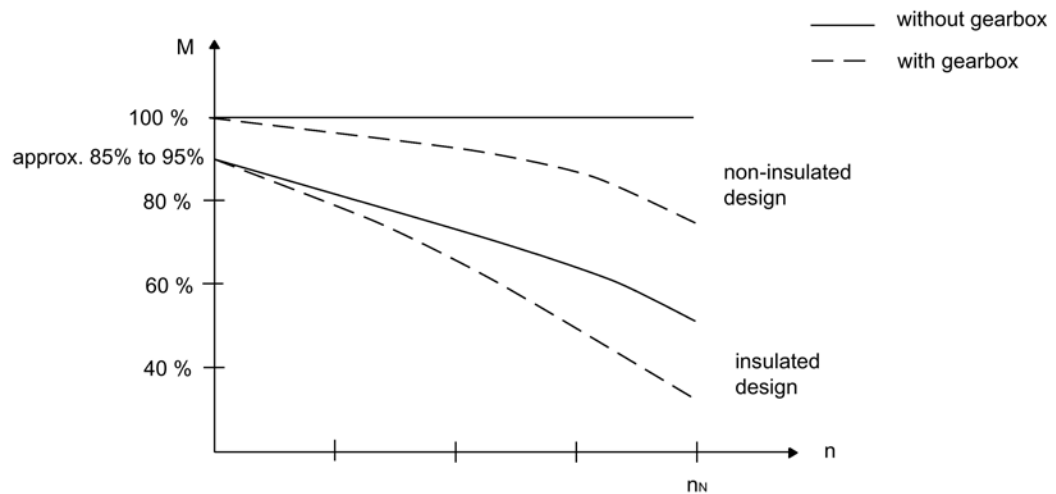

Figure 4-2 Basic effect of the mounting conditions on the S1 characteristic curve; M corresponds to the utilization of the torque

## 4.5 Pushing on the output elements

### NOTICE

#### Damage to the motor due to runout on the shaft extension

Runout and thrust on the shaft extension of the motor can damage the motor.

- Mount the motor without runout and thrust on the shaft extension.

Mount or remove the power output elements (e.g. couplings, gear wheels, belt pulleys) using suitable devices only (see figure).

- Use the threaded hole in the shaft extension.
- If required, heat up the output elements.
- When removing the output elements, use an intermediate disk to protect the centering in the shaft extension.
- If necessary, completely balance the motor together with the output elements according to ISO1940.

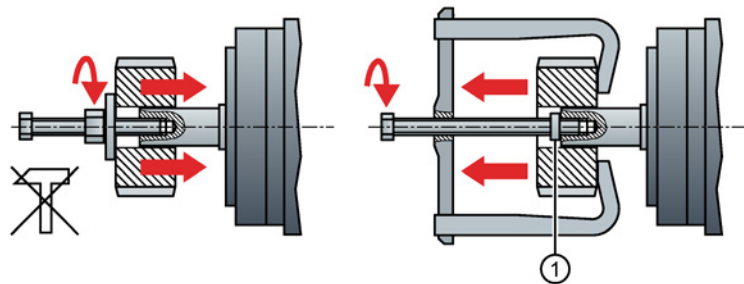

1 Intermediate washer/disk (to protect the centering in the shaft extension)

Figure 4-3 Mounting and removing output elements

## 4.6 Vibration response

Motors with a keyway are balanced with a half feather key by the manufacturer. The vibration response of the system at the location of use is influenced by output elements, any built-on parts, the alignment, the installation, and external vibrations. As a result, the motor's vibration values may change.

The motors conform to vibration severity grade A according to EN 60034-14 (IEC 60034-14).

The values indicated refer only to the motor. These values can be increased at the motor due to the overall vibration characteristics of the complete system after the drive has been installed.

The vibration severity grade is maintained up to the rated speed ( $n_N$ ).

Standard: Vibration severity grade A

Option: Vibration severity grade R (compliance with vibration severity grades A and R up to  $n_N$ )

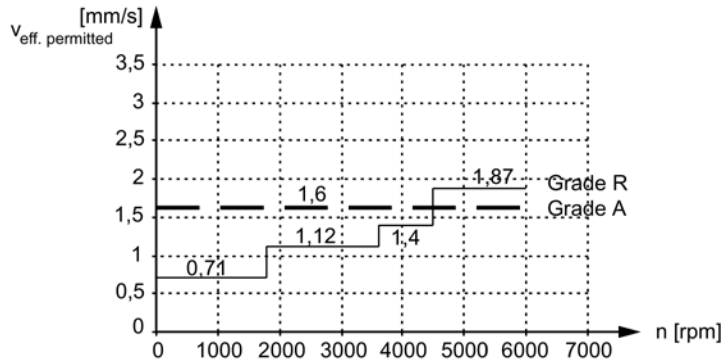

Figure 4-4 Vibration severity grades

## 4.7 Mounting the water cooling

<b>! WARNING</b>
<b>Defective work on the cooling circuit</b>
Defective work on the cooling circuit can cause injury and/or damage to property.
<ul style="list-style-type: none"><li>• Only qualified personnel may assemble, install, and commission the cooling circuit.</li><li>• Perform installation or service work on the cooling circuit only when the system is de-energized.</li></ul>

## Materials used in the motor cooling circuit

The materials used in the cooling circuit must be coordinated with the materials in the motor.

Table 4- 4 Materials used in the motor cooling circuit

Shaft height	Bearing shield	Pipes in the stator
1FT706x	Cast iron (EN-GJL-200)	Stainless steel
1FT708x	Cast iron (EN-GJL-200)	Stainless steel
1FT710x	Cast iron (EN-GJL-200)	Stainless steel

### 4.7.1 Materials for the cooling circuit

#### Materials and components in the cooling circuit

The following table lists a wide variety of materials and components that may or must not be used in a cooling circuit.

Table 4- 5 Materials and components of a cooling circuit

Material	Used as	Description
Zinc	Pipes, valves and fittings	Use is not permitted.
Brass	Pipes, valves and fittings	Can be used in closed circuits with inhibitor.
Copper	Pipes, valves and fittings	Can be used only in closed circuits with inhibitors in which the heat sink and copper component are separated (e.g. connection hose on units).
Common steel (e.g. St37)	Pipes	Permissible in closed circuits and semi-open circuits with inhibitors or Antifrogen N, check for oxide formation, inspection window recommended.
Cast steel, cast iron	Pipes, motors	Closed circuit and use of strainers and flushback filters. Fe separator for stainless heat sink.
High-alloy steel, Group 1 (V2A)	Pipes, valves and fittings	Can be used for drinking or tap water with a chloride content up to < 250 ppm, suitable according to definition in Chapter "Cooling water."
High-alloy steel, Group 2 (V4A)	Pipes, valves and fittings	Can be used for drinking or tap water with a chloride content up to < 250 ppm, suitable according to definition in Chapter "Cooling water."
ABS (AcrylnitrileButadieneStyrene)	Pipes, valves and fittings	Suitable according to definition in Chapter "Cooling water." Suitable for mixing with inhibitor and/or biocide as well as Antifrogen N.
Installation comprising different materials (mixed installation)	Pipes, valves and fittings	Use is not permitted.
PVC	Pipes, valves, fittings and hoses	Use is not permitted.
Hoses		Reduce the use of hoses to a minimum (device connection). Must not be used as the main pipe for the whole system. Recommendation: EPDM hoses with an electrical resistance > 10 <sup>9</sup> Ω (e.g. Semperflex FKD supplied from Semperit or DEMITTEL; from PE/EPD, supplied from Telle).
Gaskets	Pipes, valves and fittings	Use of FPM (Viton), AFM34, EPDM is recommended.
Hose connections	Transition Hose - pipe	Secure with clips conforming to DIN 2817, available e.g. from Telle.

4.7 Mounting the water cooling

The following recommendation applies in order to achieve an optimum motor heatsink (enclosure) lifetime:

- Use a closed cooling circuit with a cooling unit using stainless steel technology. The heat is dissipated via a water-to-water heat exchanger.
- Use ABS, stainless steel, or general construction steel for all other components, such as pipes and fittings.

4.7.2 Mounting the water cooling

The motor is connected to the cooling circuit by means of two female threads at the rear of the motor. The inlet and outlet connections can be freely selected.

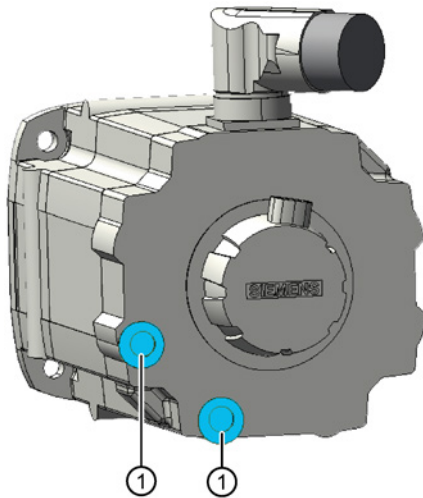

1 Connecting the water cooling system (1/4" female thread)

Figure 4-5 1FT7 water cooling connection

Mount the configured cooling circuit.



---

**Note**

**Installing the cooling water pipes**

Electrically conductive cooling water pipes must not come into contact with live components.

- Ensure adequate insulation.
  - Securely fasten the pipes.
- 

1. Match the installation materials with the materials used in the motor, see Chapter "Materials for the cooling circuit (Page 63)
2. Make sure that the cooling water meets the required cooling water specification, see Chapter "Water cooling (Page 42)."
3. Make sure that the appropriate volume of cooling water is available (see the rating plate).
4. Flush the cooling water pipes.



5. Screw the cooling water pipes into the 1/4" female threads.
6. Provide all components in the cooling system (motor, heat exchanger, piping system, pump, pressure equalization tank, etc.) with equipotential bonding.
7. Vent the cooling system.
8. Check the cooling system for leaks.
9. Ensure that the maximum permissible operating pressure does not exceed 6 bar, see Chapter "Water cooling (Page 42)".



You have mounted the water cooling.

### Pressure adjustment

If various components are connected up in the cooling circuit, it may be necessary to measure the inlet and outlet pressure and adjust accordingly.

---

#### Note

Mount flow restrictors on the cooling water outlet of the motor or the relevant component!

---

- Adjust the pressure, if necessary.

### Maximum permissible pressure drop

<b>NOTICE</b>
<b>Motor damage caused by cavitation and abrasion</b>
An excessive pressure drop causes cavitation or abrasion damage.
<ul style="list-style-type: none"> <li>• Do not exceed the maximum permissible pressure drop.</li> </ul>

During continuous running, the maximum permissible pressure drop across a motor can be 0.2 MPa (2 bar).

### Maintenance and service

It is recommended that the filling level and discoloration or cloudiness of the cooling water is checked at least once a year. Furthermore, every year it must be checked that the cooling water still meets the permissible specification.

If the cooling water level has dropped, the loss should be corrected on closed or semi-open circuits with a prepared mixture of deionized water and inhibitor or Antifrogen N.

## 4.8 Mounting the sealing air connection

The 1FT7 motors can be protected from the ingress of very creep-capable media with sealing air.

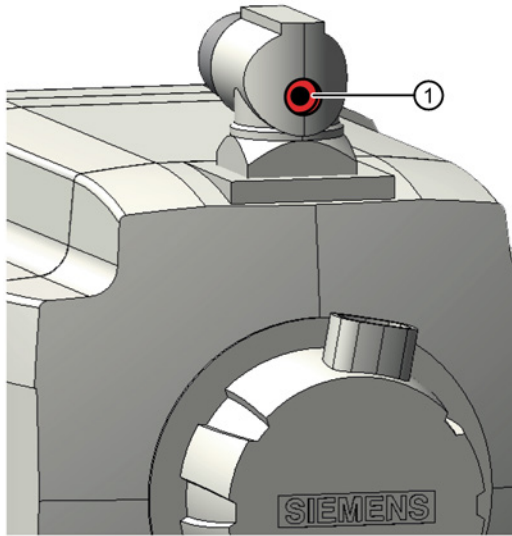

- 1 Sealing air connection (as delivered, the sealing air connection is closed with a sealed hexagon socket-head screw).

Figure 4-6 1FT7 sealing air connection

The sealing air connection is located in the power connector.

### Technical specifications of the sealing air connection

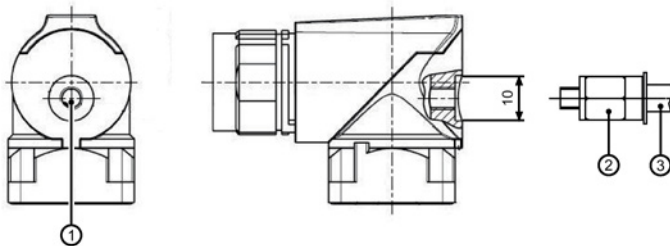

- 1 Sealing air connection M5
- 2 Connector nipple, e.g. Festo QSM-B-M5-4-20
- 3 Tube, outside diameter 4 mm, inside diameter 2.5 mm.

Mount the sealing air connection with a tightening torque of 3.5 Nm to 5 Nm.

### Requirements of the sealing air supply

Conditioning the sealing air	
Minimum inlet temperature (°C)	Ambient temperature
Maximal inlet temperature (°C)	35
Maximum residual water content (g/m <sup>3</sup> )	0.12

Maximum residual oil content (g/m <sup>3</sup> )	0.01
Maximum residual dust (mg/m <sup>3</sup> )	0.1
Minimum supply pressure (Pa)	0.05 x 10 <sup>5</sup>
Maximum supply pressure (Pa)	0.1 x 10 <sup>5</sup>
Particle size for hollow shaft encoders (µm)	< 8
Particle size for optical encoders (µm)	< 3
Volume	
Volume (Nm <sup>3</sup> /h) (Nm <sup>3</sup> = standard cubic meters)	1 - 1.5

### Mounting the sealing air connection

#### Procedure

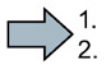

- 1.
- 2.

1. Remove the sealed hexagon socket-head screw.
2. Screw the connection into the connector.
3. Tighten the sealing air connection with a torque of 3.5 Nm to 5 Nm.



You have mounted the sealing air connection.



## 5.1 Safety instructions



**! DANGER**

**Danger to life due to live parts and other energy sources**

Death or serious injury can result when live parts are touched.

- Only work on electrical devices when you are qualified for this job.
- Always observe the country-specific safety rules.

Generally, six steps apply when establishing safety:

1. Prepare for shutdown and notify all those who will be affected by the procedure.
2. Disconnect the machine from the supply.
  - Switch off the machine.
  - Wait until the discharge time specified on the warning labels has elapsed.
  - Check that it really is in a no-voltage condition, from phase conductor to phase conductor and phase conductor to protective conductor.
  - Check whether the existing auxiliary supply circuits are de-energized.
  - Ensure that the motors cannot move.
3. Identify all other dangerous energy sources, e.g. compressed air, hydraulic systems, or water.
4. Isolate or neutralize all hazardous energy sources by closing switches, grounding or short-circuiting or closing valves, for example.
5. Secure the energy sources against switching on again.
6. Ensure that the correct machine is completely interlocked.

After you have completed the work, restore the operational readiness in the inverse sequence.

**⚠ WARNING**

**Danger to life as a result of hazardous voltages when connected to inadequately grounded line supplies**

Connecting a motor to an inadequately grounded line supply can result in death, severe injury and damage to the motor if a fault occurs.

- Connect motors, as part of the drive system, to TN and TT line supplies with a grounded neutral point or to IT line supplies.
- Ensure that the SINAMICS devices and motors are compatible with the residual current device according to EN 61800-5-1 before you connect the devices and motors to the line supply using residual current devices (RCDs).
- For line supplies with grounded line conductor, e.g. TT line supplies, use an isolating transformer with grounded neutral point (on the secondary side) between the line supply and the drive system, so that the motor insulation is not overstressed.
- When connected to IT line supplies, a monitoring device must signal the first fault between an active part and ground. Eliminate this fault immediately.

## 5.2 Permissible line systems

In combination with the drive system, the motors are generally approved for operation on TN and TT systems with **grounded neutral** and on IT systems.

In operation on IT systems, the occurrence of a first fault between an active part and ground must be signaled by a monitoring device. According to IEC 60364-4-41, it is recommended that the first fault is removed as quickly as is practically possible.

In systems with a **grounded external conductor**, an isolating transformer with grounded neutral (secondary side) must be connected between the line supply and the drive system to protect the motor insulation from excessive stress. The majority of TT systems have a grounded external conductor, so in this case an isolating transformer must be used.

## 5.3 Motor circuit diagram

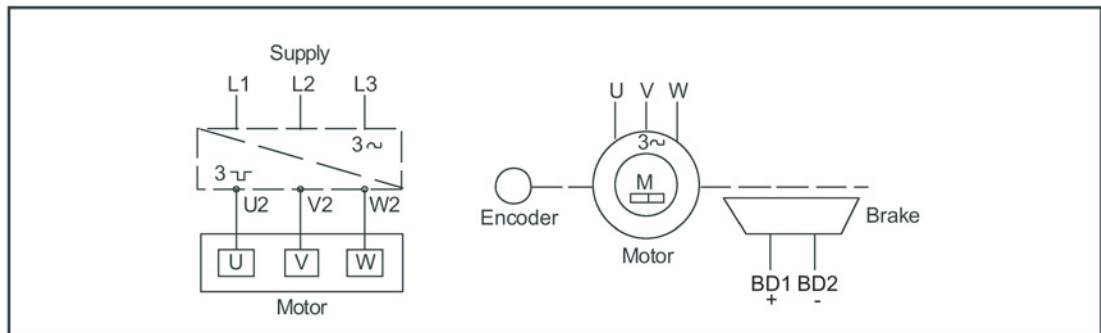

Figure 5-1 Circuit diagram

## 5.4 System integration

### 5.4.1 Connection notes

#### 5.4.1.1 Motor connection

**NOTICE****Destruction of the motor if it is directly connected to the three-phase line supply**

The motor will be destroyed if it is directly connected to the three-phase line supply.

- Only operate the motors with the appropriately configured converters.

**NOTICE****Damage to electronic components as a result of electrostatic discharge**

Electrostatically sensitive devices (ESD) can be damaged or destroyed by electrostatic discharge.

- Observe the ESD protection measures.
- Only grounded personnel with grounded tools may touch the component connections.
- Heed the EMC information provided by the manufacturer of the converter.

- Use prefabricated cables from SIEMENS (not in the scope of delivery). These cables reduce installation costs and increase operational reliability (see the Product Information).
- The manufacturer of the system/machine is responsible for the proper installation.
- Observe the data on the rating plate and the circuit diagrams.
- Adapt the connecting cables to the type of use and the voltages and currents that occur.
- When fed from a converter, high-frequency current and voltage oscillations in the motor feeder cables can cause electromagnetic interference. Therefore, use shielded power cables.
- Heed the EMC information provided by the manufacturer of the converter.
- Make sure that the inside of the connector is clean and free of cable cuttings and moisture.
- Avoid protruding wire ends.
- Check that the degree of protection is complied with at the seals and sealing surfaces of the connectors.
- Secure connecting cables against torsion, tensile and compressive strain, and protect them against kinking. It is not permissible to subject the connector to continuous force.
- Insert the coding groove of the plug-in connection into the socket until flush and tighten the screw cap by hand in as far as it will go.

**Current-carrying capacity for power and signal cables**

The current-carrying capacity of PVC/PUR-insulated copper cables is specified for routing types B1, B2 and C under continuous operating conditions in the table with reference to an ambient air temperature of 40° C. For other ambient temperatures, the values must be corrected by the factors from the "Derating factors" table.

Table 5- 1 Cable cross-section and current-carrying capacity

Cross-section [mm <sup>2</sup> ]	Current-carrying capacity, AC rms 50/60 Hz or DC for routing type			
	B1 [A]	B2 [A]	C [A]	E [A]
<b>Electronics (according to EN 60204-1)</b>				
0.20	-	4.3	4.4	4.4
0.50	-	7.5	7.5	7.8
0.75	-	9	9.5	10
<b>Power (according to EN 60204-1)</b>				
0.75	8.6	8.5	9.8	10.4
1.00	10.3	10.1	11.7	12.4
1.50	13.5	13.1	15.2	16.1
2.50	18.3	17.4	21	22
4	24	23	28	30
6	31	30	36	37
10	44	40	50	52
16	59	54	66	70
25	77	70	84	88
35	96	86	104	110
50	117	103	125	133
70	149	130	160	171
95	180	165	194	207
120	208	179	225	240
<b>Power (according to IEC 60364-5-52)</b>				
150	239 <sup>1)</sup>	206 <sup>1)</sup>	259 <sup>1)</sup>	276 <sup>1)</sup>
185	274 <sup>1)</sup>	235 <sup>1)</sup>	296 <sup>1)</sup>	315 <sup>1)</sup>
> 185	Consult the standard for the values.			

<sup>1)</sup> Extrapolated values

Table 5- 2 Derating factors for power and signal cables

Ambient air temperature [°C]	Derating factor according to EN 60204-1, Table D1
30	1.15
35	1.08
40	1.00
45	0.91
50	0.82
55	0.71



### 5.4.1.2 Rotating the connector at the motor

Power connectors and signal connectors can be rotated to a different angle to a limited extent.

Use a suitable socket connector to rotate the angle plug.

Unscrew and open the socket connector completely to avoid damaging the pin contacts.

On encoders with an integrated Sensor Module (DQI), the cable outlet toward the top is fixed and cannot be changed.

**Note**

**Rotating the connectors**

- Do not exceed the permissible range of rotation.
- To ensure the degree of protection, do not rotate more than 10 times.
- Rotate the connector using a mating connector that matches the connector thread. Only rotate Sensor Modules by hand. Use of tools is not permissible.

**Ability to rotate the power connector on motors with natural cooling / water water cooling and DRIVE-CLiQ interface 1FT7□□□-□A□□□-□X□□, 1FT7□□□-□W□□□-□X□□; X = B, C**

Table 5- 3 Rotation range of the power connector

Motor	Angle $\alpha$	Angle $\beta$	Connector size	Drawing
1FT703 1FT704	130°	130°	1	
1FT706 1FT708	130°	135°	1	
1FT706	160°	120°	1.5	
1FT708	170°	120°		
1FT710 1FT713	190°	135°		

Ability to rotate the connectors on motors with natural cooling / water cooling without a DRIVE-CLiQ interface and on motors with a DRIVE-CLiQ interface via Sensor Modules  
 1FT7□□□-□A□□□-□X□□, 1FT7□□□-□W□□□-□X□□; X = M, N, D, F

Table 5- 4 Rotation range of the power connector ①

Motor	Angle $\alpha$	Angle $\beta$	Connector size	Drawing
1FT703 1FT704	115°	145°	1	
1FT706	130°	145°		
1FT708	130°	150°		
1FT706	130°	135°	1.5	
1FT708	140°	135°		
1FT708 1FT710 1FT713	190°	135°		

Table 5- 5 Rotation range of the signal connector ②

Motor	with DRIVE-CLiQ via Sensor Module		M23 connector		M17 connector		Drawing
	Angle $\alpha'$	Angle $\beta'$	Angle $\alpha'$	Angle $\beta'$	Angle $\alpha'$	Angle $\beta'$	
1FT703 1FT704	145°	120°	145°	120°	125°	130°	See "Power connectors" table
1FT706	100°	95°	115°	110°	115°	110°	
1FT708	95°	95°	100°	95°	105°	100°	
1FT710 1FT7117 1FT713	95°	95°	95°	95°	95°	95°	

**Ability to rotate the power connectors for the motor and the fan for motors with forced ventilation  
1FT7□□□-□S□□□-□□□□**

Table 5- 6 Rotation range of the power connector for the motor ①

Motor	Angle $\alpha$	Angle $\beta$	Connector size	Drawing
1FT706	165°	125°	1.5	
1FT708	110°	110°		
1FT710	185°	135°		
1FT713	cannot be rotated		3	

Table 5- 7 Ability to rotate the signal connector (not visible, under the fan cover or in the intermediate flange) ②

Motor	with DRIVE-CLiQ via Sensor Modules, M23 or M17 connector		Drawing
	Angle $\alpha'$	Angle $\beta'$	
1FT706 1FT708 1FT710 1FT713	can only be set permanently to 90° 1)	can only be set permanently to 90° 1)	See "Power connectors for natural cooling / water cooling" table

1) For other angles, the signal line can come into contact with the fan and so be damaged.

Table 5- 8 Rotation range of the power connector for the fan ③

Motor		Connector size 1		Drawing
		Angle $\alpha'$	Angle $\beta'$	
1FT706 1FT708		155°	130°	See "Power connectors" table
1FT710		150°	130°	
1FT713	with power connector, size 3	75°	60°	
	with terminal box	15°	70°	

Table 5-9 Max. torque when rotating

Connectors	Max. torque when rotating
Power connector, size 1	12 Nm
Power connector, size 1.5	20 Nm
Signal connector (without DRIVE-CLiQ)	12 Nm
Signal connector (with DRIVE-CLiQ)	8 Nm

5.4.1.3 Routing cables in a damp environment

**Note**

If the motor is mounted in a humid environment, the power and signal cables must be routed as shown in the following figure.

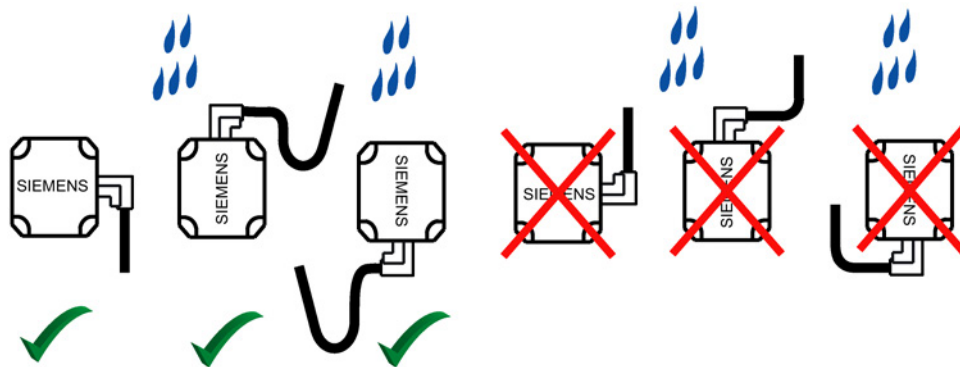

Figure 5-2 Routing cables in a damp environment

5.4.2 Connecting to a converter

Selecting and connecting the cables

- To connect the motor to a converter, use MOTION-CONNECT cables or shielded connecting cables.

**Note**

The cable shielding, made up of as many strands as possible, must have a high electrical conductivity. Braided shields made of copper or aluminum are well suited.

**Connection scheme for the motor to the S120 Power Module and Motor Module Booksize and Compact with a MOTION CONNECT cable**

for connector size 1

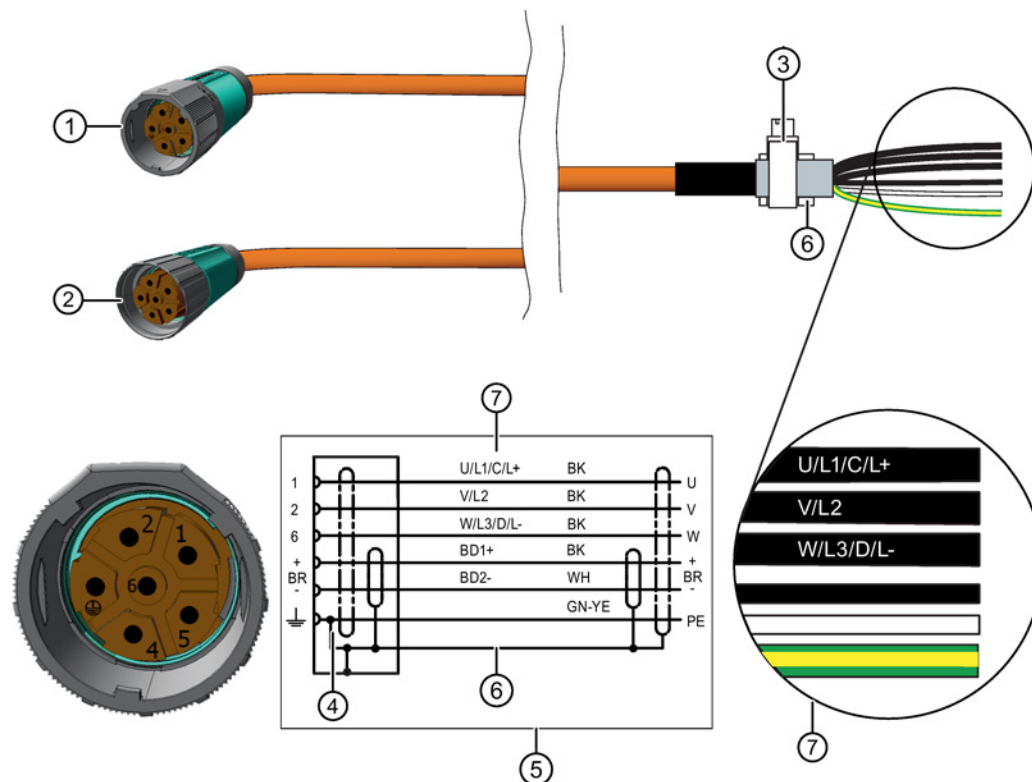

- 1 Connector size 1
- 2 SPEED-CONNECT 1 connector
- 3 Terminal for the cable shield
- 4 Pin assignment
- 5 Circuit diagram
- 6 Cable shield
- 7 Conductor designation:  
 U, V, W = power cables, 1.5 mm<sup>2</sup>, each cable separately shielded  
 BD1+ and BD2- = brake cable without lettering, 1.5 mm<sup>2</sup>, shared shield  
 PE = protective conductor

For connector size 1.5

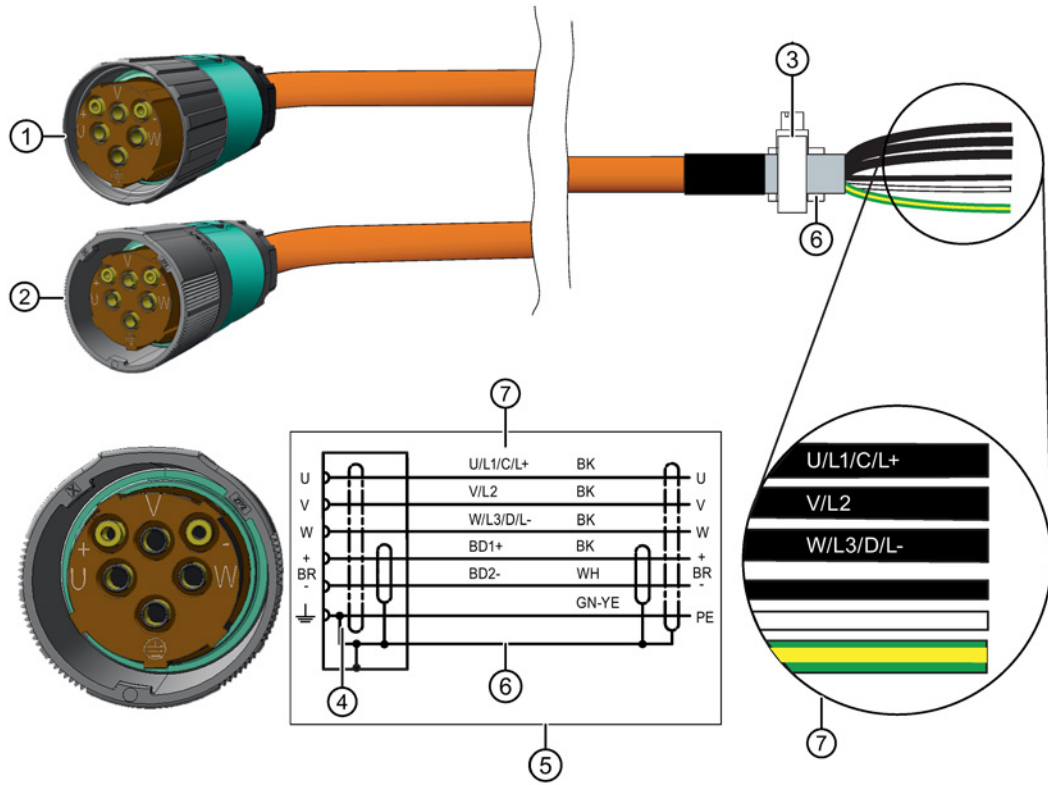

- 1 Connector size 1.5
- 2 SPEED-CONNECT 1.5 connector
- 3 Terminal for the cable shield
- 4 Pin assignment
- 5 Circuit diagram
- 6 Cable shield
- 7 Conductor designation:  
 U; V; W = power cables, each cable separately shielded  
 BD1+ and BD2- = brake cable without lettering, 1.5 mm<sup>2</sup>, shared shield  
 PE = protective conductor

For connector size 3

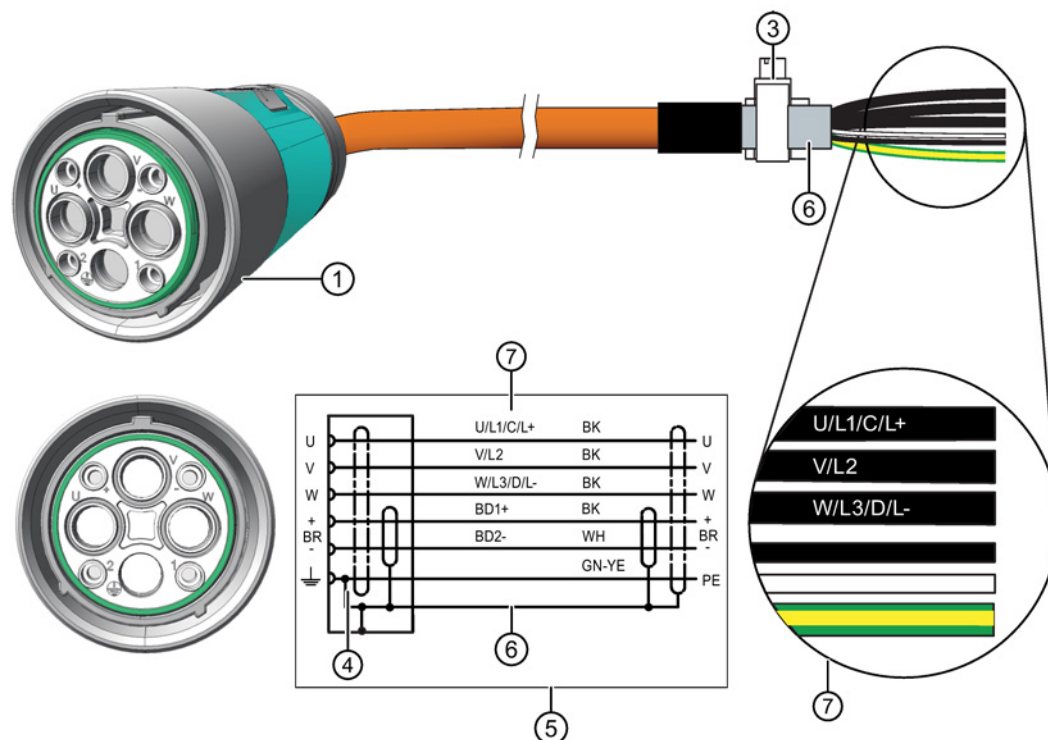

- 1 Connector size 3
- 2 n.a.
- 3 Terminal for the cable shield
- 4 Pin assignment
- 5 Circuit diagram
- 6 Cable shield
- 7 Conductor designation:  
 U; V; W = power cables, each cable separately shielded  
 BD1+ and BD2- = brake cable without lettering, 1.5 mm<sup>2</sup>, shared shield  
 PE = protective conductor

- Connect the shield at both ends at the motor and at the converter.
- Keep unshielded cable ends as short as possible.
- To ensure good conducting of high-frequency currents, provide contacting over a large surface area. Establish a 360° connection at the converter and at the motor, for instance using EMC cable glands at the cable entries.

### 5.4.3 Connecting the forced ventilation

**Connection notes**

The fan connection is a size 1 power connector.

- Use only cables that comply with the installation regulations.
- Before connecting the device, make sure that the line voltage matches the device voltage.
- Check whether the data on the fan rating plate matches the connection data.
- Lay the connection cables without tensile stress.

**NOTICE**

**Damage to the fan when inappropriately operated**

As supplied, the external fan does not provide an independently functioning protection against improper operation (blocking protection). The device can become hot and start to burn.

- Use blocking protection (stall protection) to protect the fan against inappropriate operation. To do this, use a suitable motor circuit-breaker where all poles can be disconnected or an appropriate activation device for the PTC thermistor. Operate the fan using the motor circuit-breaker.
- Provide a protective circuit that prevents the main motor from being switched on when the fan is not in operation.

#### Connection of a 1-phase external fan

Table 5- 10 Connection values for a 1-phase external fan for the 1FT7 up to shaft height 100

Shaft height	Max. current consumption at	
	230 V / 50 Hz (±10%) [A]	230 V / 60 Hz (±10%) [A]
63	< 0.1	< 0.1
80 to 100	0.40	0.45



Circuit diagram

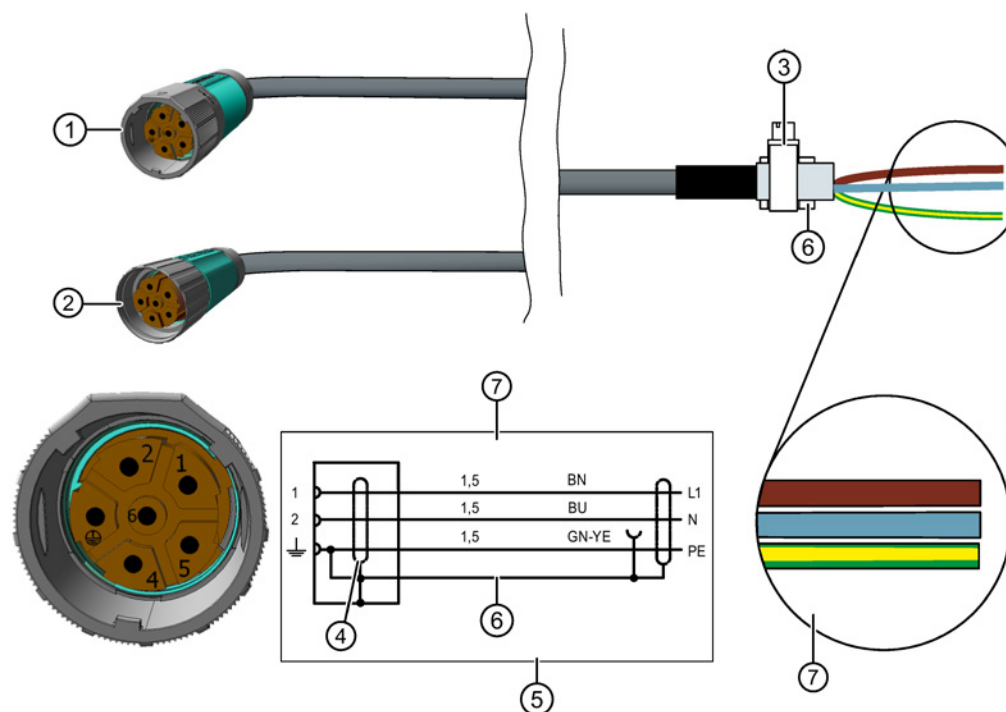

- 1 Connector size 1 (with full thread)
- 2 SPEED-CONNECT connection plug, size 1
- 3 Terminal for the cable shield
- 4 Pin assignment
- 5 Circuit diagram
- 6 Cable shield
- 7 Conductor designation:  
 Power cable, 1.5 mm<sup>2</sup>  
 PE = protective conductor, 1.5 mm<sup>2</sup>

Figure 5-3 Connecting to a 1-phase external fan

Connection of a 3-phase external fan

Table 5- 11 Connection values for a 3-phase external fan for the 1FT7 shaft height 132

Shaft height	Max. current consumption at		
	400 V / 50 Hz (±10%) [A]	400 V / 60 Hz (±10%) [A]	480 V / 60 Hz (±10%) [A]
132	0.21	0.19	0.23

Circuit diagram

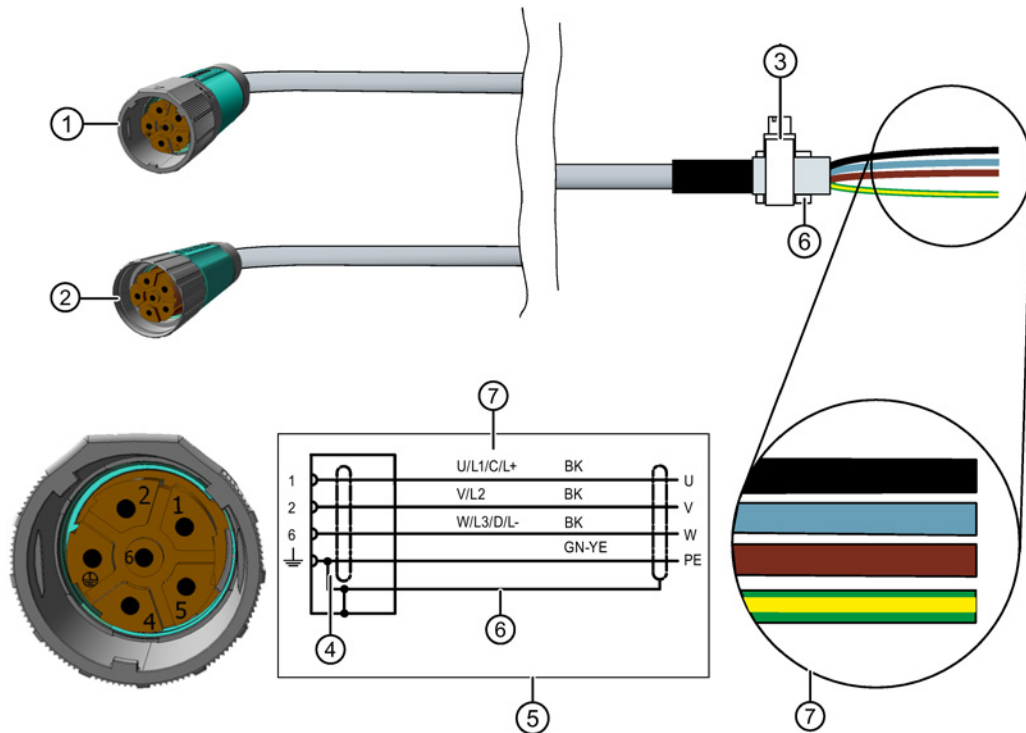

- 1 Connection plug size 1 (with full thread)
- 2 SPEED-CONNECT connection plug, size 1
- 3 Terminal for the cable shield
- 4 Pin assignment
- 5 Circuit diagram
- 6 Cable shield
- 7 Conductor designation:  
Power cable, 1.5 mm<sup>2</sup>  
PE = protective conductor, 1.5 mm<sup>2</sup>

Figure 5-4 Connecting to a 3-phase external fan, plug size 1

Table 5- 12 Order numbers

	Order number (article number)
Connector size 1 with full thread	6FX2003-0LU00
Connector size 1 with SPEED-CONNECT	6FX2003-0LU30
Prefabricated cable with full thread	6FX5001-5CG10-□□□□ <sup>1)</sup>
Prefabricated cable with SPEED-CONNECT	6FX5002-5CG10-□□□□ <sup>1)</sup>

<sup>1)</sup> The last 4 positions are the length code. Additional information is contained in Catalog D 21.4 (2017), page 12/7 ff.

Link to the catalogD 21.4 (<https://intranet.for.siemens.com/org/i-dt-mc/en/motion-control/support/marketing-materials/catalogs/d-21-4-sinamics-s120-simotics/Pages/d-21-4.aspx#>)

## 5.4.4 Connecting the holding brake

### Direct connection

The holding brake in the motor is intended for direct connection to the SINAMICS converter using the MOTION CONNECT power cable with an integrated brake connection cable. See Chapter "Connecting to a converter (Page 76)"

### Connection to external power supply

The holding brake can be operated via an external power supply.

The external power supply can be a PELV (PELV = Protective Extra Low Voltage) supply:

- if safe electrical isolation from the motor winding is guaranteed for the brake cable in the motor and
- if the power cable has a reinforced insulation.

---

### Note

The relay K1, located between coil and contact, must also have reinforced insulation to protect the internal logic voltage.

---

If you control the holding brake via an external power supply, you must protect the holding brake from voltage peaks with a protective circuit. See figure "Suggested circuit for the external power supply"

The protective circuit also ensures the specified switching times. See table "Technical data for the the holding brake used" in the associated Configuration Manual.

To ensure reliable opening of the motor holding brake, it requires a 24 V ± 10% voltage supply at the motor connection.

It must be taken into account that voltage dips can occur along the supply cable.

- Use a Control Supply Module (CSM) or a regulated DC power supply, whose setpoint is set to 26 V.
- Use supply cables with a minimum cross-section of 1.5 mm<sup>2</sup> and a maximum length of 100 m.

If the maximum voltage of 24 VDC +10% is exceeded, the brake can re-close.

You can calculate the voltage drop  $\Delta U$  for copper cables approximately as follows:

$$\Delta U [V] = 0.042 \times (l/q) \times I_{\text{brake}}$$

$l$  = Cable length [m]

$q$  = Brake core cross-section [mm<sup>2</sup>]

$I_{\text{brake}}$  = Direct current of the brake [A]

**Note**

Integrate a protective circuit into the incoming cable. In this way, you avoid switching overvoltages and possible influence of the installation environment. See the figure below

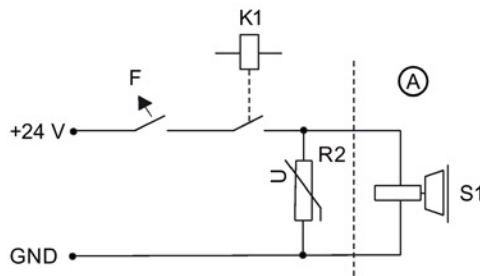

- A Motor
- K1 Contactor
- F Circuit-breaker
- S1 Holding brake
- R2 Varistors

Figure 5-5 Suggested circuit for the external power supply with protective circuit

Table 5- 13 Example: Electrical components for the suggested circuit

Electrical component	Examples		
F	3RV10 circuit-breaker with current paths connected in series (if required with mounted auxiliary contact 3RV1901 to provide a feedback signal for the drive).	or	Miniature circuit-breaker 5SX21 (if required with mounted auxiliary contact to provide a feedback signal for the drive).
K1	Auxiliary contactor 3RH11	or	Contactors 3RT10
R2	Varistor SIOVS14K30 (EPCOS)		

## 5.4.5 Line connection

### 5.4.5.1 Terminal box versions

#### Power connection via terminal box

For electrical connection of the 1FT7, the following terminal boxes can be used for larger shaft heights:

GK 230	GK843
1FT7085	1FT7132
1FT7087	1FT7134
1FT7105	1FT7136
1FT7108	1FT7138

#### Information on connecting

- Use cable lugs according to DIN 46234 for connection.
- First connect the protective conductor.
- Implement the terminal assignment in the terminal box as shown in the figure.
- Connect the brake if there is one.

#### Terminal diagram terminal box GK 230

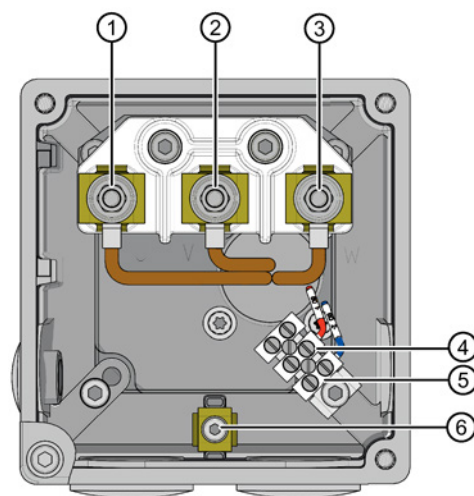

- 1, 2, 3 Main terminals U, V, W  
 4, 5 Brake connection (optional), 4 = BD1+, 5 = BD2-  
 6 Ground connection

Figure 5-6 Terminal box GK 230

Table 5- 14 Terminals for the terminal box GK 230

Terminal box type	GK 230
Cable entry	1 x PG 29 / 1 x PG 9
Max. outer cable diameter <sup>1)</sup>	30 mm
RMS current per terminal <sup>2)</sup>	66 A
Number of main terminals U, V, W	3 x M5
Max. cross-section per terminal	1 x 16 mm <sup>2</sup>
Ground connection	M4
Tightening torque [Nm]	0.8 - 1.2
Brake connection <sup>3)</sup>	1.5 mm <sup>2</sup>

1) Depends on the seal used

2) Data according to DIN EN 60204-1 (routing type C, ambient temperature 40° C)

3) BD1+/BD2- (terminal strip, only for versions with brake)

**Terminal diagram terminal box GK 843**

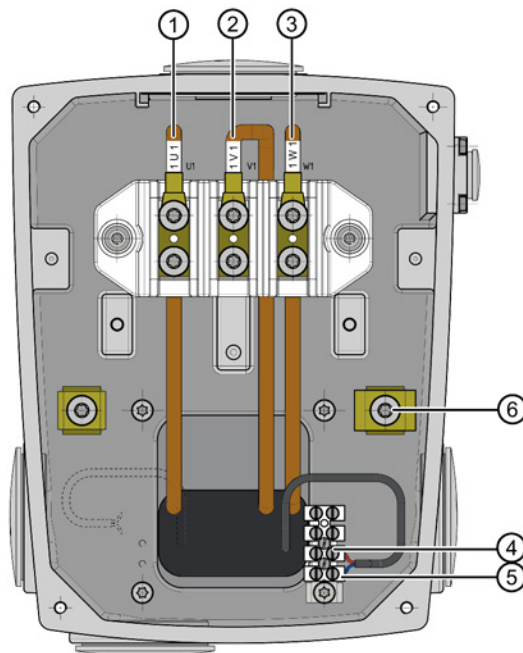

1, 2, 3 Main terminals U, V, W

4, 5 Brake connection (optional), 4 = BD1+, 5 = BD2-

6 Ground connection

Figure 5-7 Terminal box GK 843

Table 5- 15 Terminals for the terminal box GK 843

Terminal box type	GK 843
Cable entry	3 x M50 x 1.5 / 1 x M16 x 1.5
Max. outer cable diameter <sup>1)</sup>	38 mm
RMS current per terminal <sup>2)</sup>	125 A
Number of main terminals U, V, W	3 x M6
Max. cross-section per terminal	1 x 50 mm <sup>2</sup>
Ground connection	M6
Tightening torque [Nm]	2.7 - 4
Brake connection <sup>3)</sup>	1.5 mm <sup>2</sup>

<sup>1)</sup> Depends on the seal used

<sup>2)</sup> Data according to DIN EN 60204-1 (routing type C, ambient temperature 40° C)

<sup>3)</sup> BD1+/BD2- (terminal strip, only for versions with brake)

### 5.4.5.2 Power connector version

#### Power connector versions

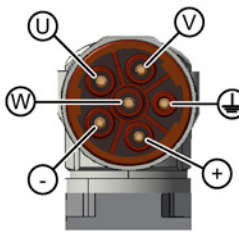
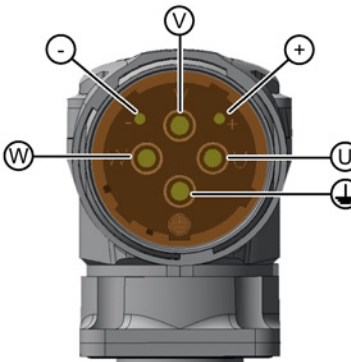
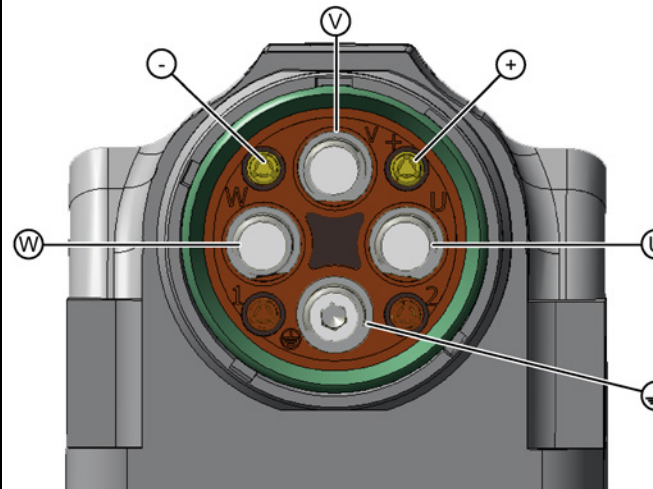
Connector size 1	Connector size 1.5	Connector size 3
		
+ = BD1+; - = BD2-	+ = BD1+; - = BD2-	+ = BD1+; - = BD2-

The motors can be connected via a quick-release lock (SPEED-CONNECT).

The motor connectors are designed in such a way that both the quick-release lock cables with SPEED-CONNECT and the conventional cables with screw-type connection can be used.

**Handling plug-in connections**

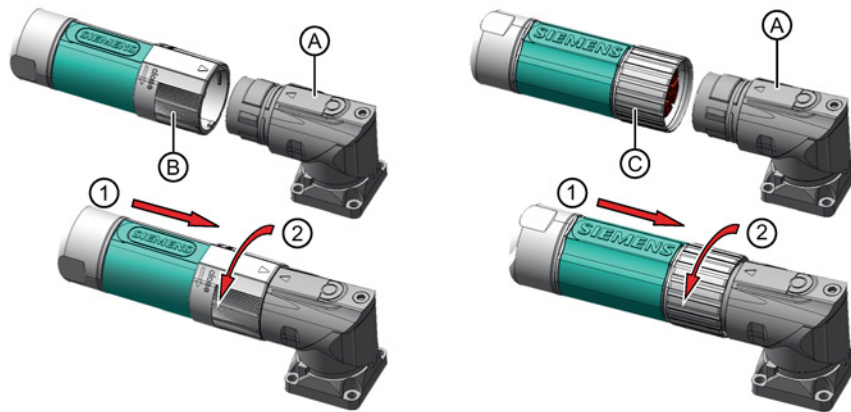

- A Motor connector, suitable for SPEED-CONNECT and screw lock
- B Connector with SPEED-CONNECT
- C Connector with screw lock
- 1 Connect together
- 2 Lock or tighten by hand

**5.4.6 Signal connection**

**5.4.6.1 Motors with DRIVE-CLiQ interface**

Motors designed for SINAMICS drive systems have an integrated encoder and temperature evaluation system as well as an electronic rating plate.

The motors are connected to the converter system via a DRIVE-CLiQ interface.

We recommend the following two variants for the DRIVE-CLiQ connection:

10-pin RJ45plus socket	Round connector M17
1 10-pin RJ45plus socket	1 round connector M17



**Differences for connection with M 17 round connector compared with RJ45plus socket**

The following differences compared with the RJ45 standard connector apply to motors with an M17 round connector:

- The motor is 5 mm longer and has the same overall length as the motor without a DRIVE-CLiQ interface.
- The connector is implemented as a rotatable angle plug.
- The height of the obstructing contour relative to the center of the motor is 82 mm.
- A non-standard signal line is required (DRIVE-CLiQ round connector M 17, IP67)

The DRIVE-CLiQ interface supplies the motor encoder with power via the integrated 24 VDC power supply. The DRIVE-CLiQ interface transfers the motor encoder and temperature signals and the electronic rating plate data, e.g. a unique identification number, rating data (voltage, current, torque) to the Control Unit.

Motors with a DRIVE-CLiQ interface can be connected to the associated Motor Module via a MOTION-CONNECT cable. The connection of the MOTION-CONNECT cable at the motor has degree of protection IP67.

<p><b>NOTICE</b></p> <p><b>Damage to electronic components as a result of electrostatic discharge</b></p> <p>The Sensor Module has direct contact with electrostatic sensitive devices that can be damaged or destroyed by electrostatic discharge (ESD).</p> <ul style="list-style-type: none"> <li>• Ensure the ESD protection measures are taken (see Handling electrostatic sensitive devices (ESD) (Page 18)).</li> <li>• Only grounded personnel with grounded tools may touch the component connections.</li> <li>• Heed the EMC information provided by the manufacturer of the converter.</li> </ul>
---

The motor and the Motor Module are connected via a MOTION-CONNECT cable.

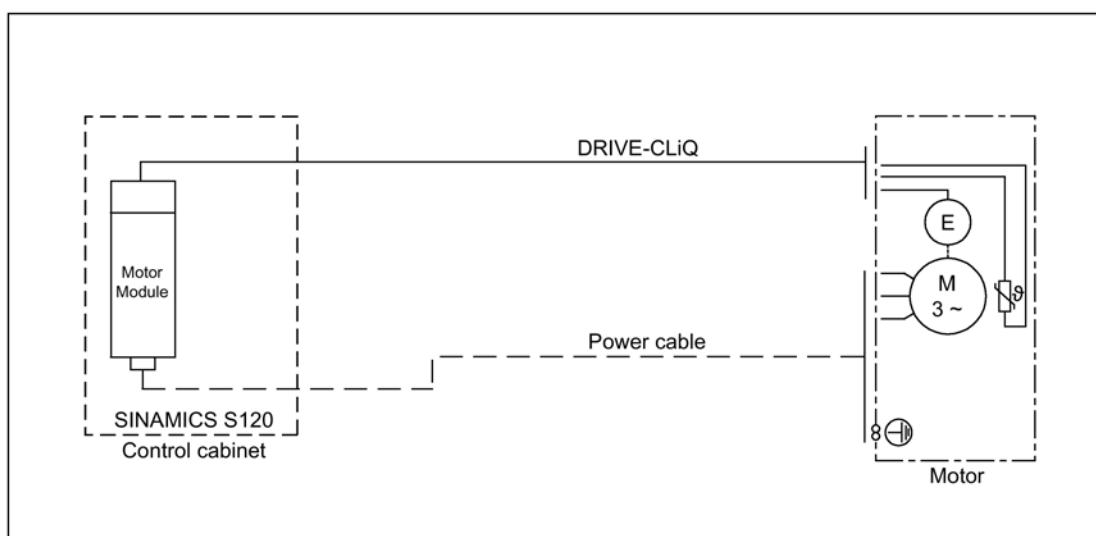
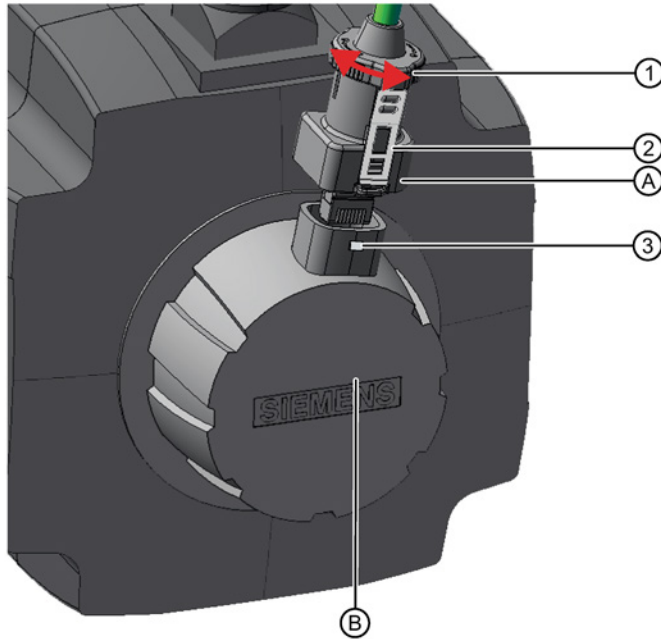

Figure 5-8 Encoder interface with DRIVE-CLiQ

### 5.4.6.2 Connecting the RJ45 DRIVE-CLiQ connector

The DRIVE-CLiQ connection method with the RJ45 connector has the following components:



- A DRIVE-CLiQ connector with RJ45Plus
- B DRIVE-CLiQ socket with RJ45plus
- 1 Rotatable locking ring
- 2 Tabs (2, opposite each other)
- 3 Latches (2, opposite each other)

**Insertion**

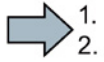

- 1.
- 2.

1. Check whether the locking ring of the connector is in the "locked" position.  
If not, turn the locking ring clockwise into the "locked" position.

---

**Note**

In the "locked" position, the tabs are flush against the connector.

---

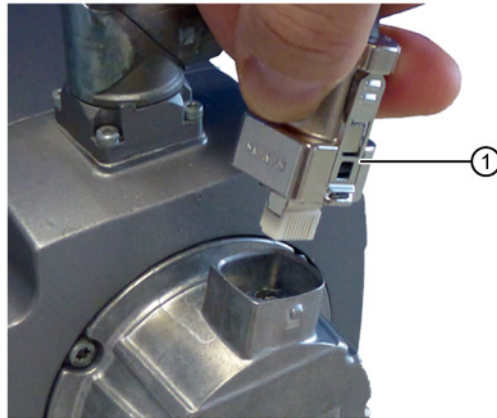

1 Locking ring in the "locked" position

2. Insert the connector into the RJ45 socket of the Sensor Module.

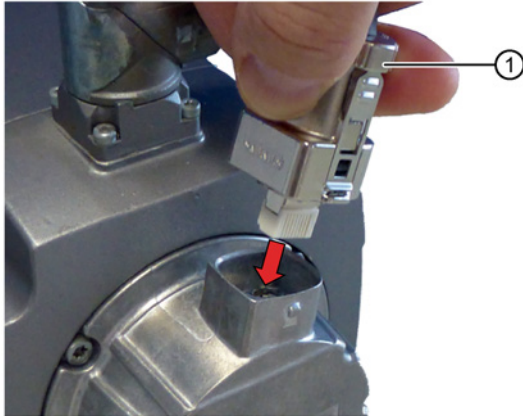

- 1 The locking ring remains in the "locked" position.

3. Check that the two tabs are engaged in both latches on the socket and that the connector cannot be pulled out.

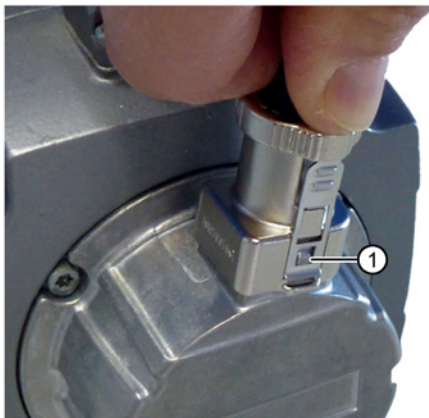

- 1 Both tabs must engage in both latches.

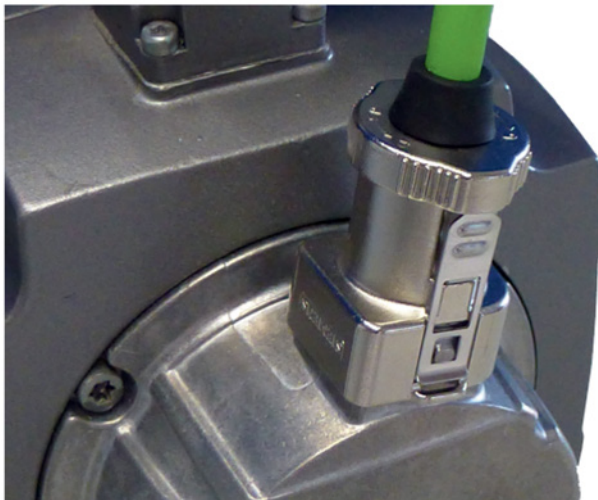

The correct DRIVE-CLiQ connection is made when

- the locking ring is in the "locked" position,
- both tabs are engaged in both latches.



You have made a DRIVE-CLiQ connection.

### Removal



- 1.
- 2.

1. Turn the locking ring of the connector counterclockwise into the "unlocked" position.

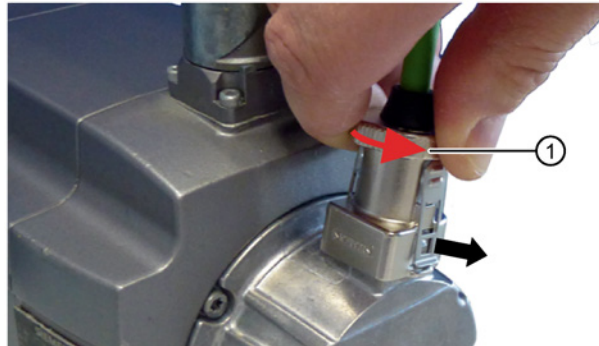

- 1 Turn the locking ring counterclockwise.  
→ Both tabs are pressed away by the latches.
2. Check that the two tabs are disengaged from the latches.
3. Pull the connector out of the RJ45 socket of the Sensor Module.

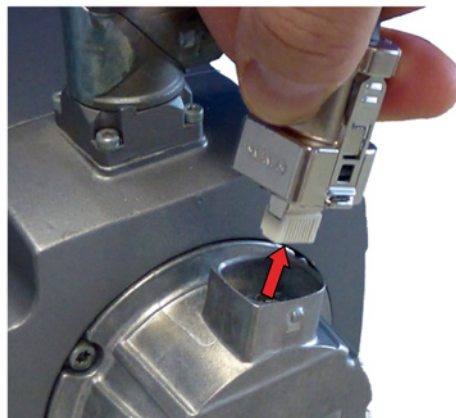

You have released the DRIVE-CLiQ connection.

### 5.4.6.3 Motors without a DRIVE-CLiQ interface

If a motor is not equipped with a DRIVE-CLiQ interface, the speed encoder and temperature sensor are connected via a signal connector.

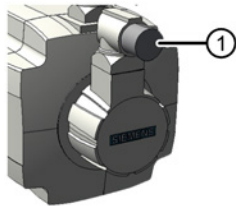

1 Signal connector

Figure 5-9 Motor with a signal connector

Motors without DRIVE-CLiQ require a Sensor Module Cabinet (SMC) for operation with a SINAMICS S120 drive system. The motor is connected to the SMC via a signal cable. The SMC is connected to the motor via a MOTION-CONNECT cable.

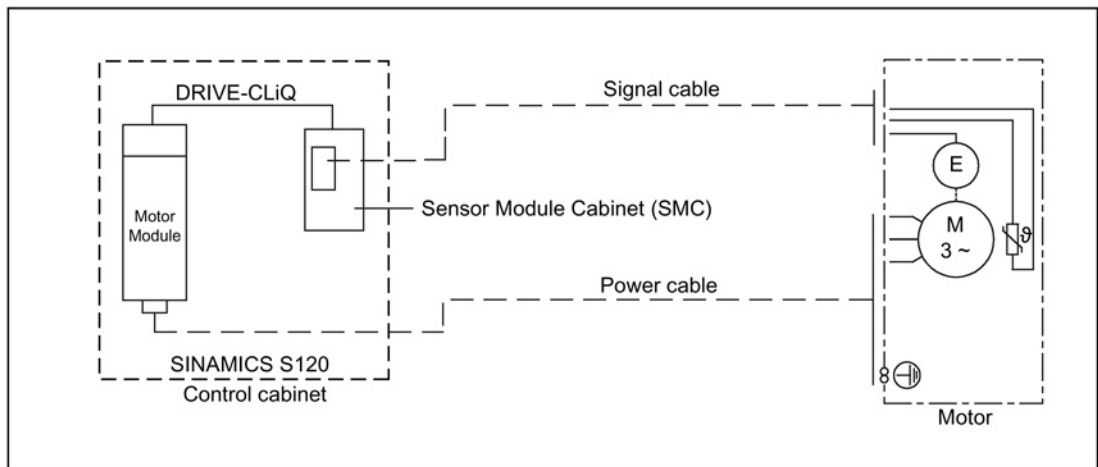

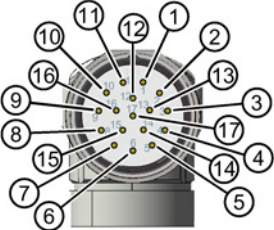

Figure 5-10 Encoder interface without DRIVE-CLiQ

### 5.4.6.4 Signal connector version

#### Signal connector versions

Pin assignment 10-pin signal connector	Pin assignment, 17-pin signal connector	
		
DQI encoder M 17	Incremental encoder sin/cos 1Vpp	Absolute encoder
1 = TX-P	1 = A	1 = A
2 = TX-N	2 = A*	2 = A*
3 = not connected	3 = R	3 = data
4 = not connected	4 = D*	4 = not connected
5 = RX-P	5 = C	5 = clock
6 = RX-N	6 = C*	6 = not connected
7 = not connected	7 = M encoder	7 = M encoder
8 = not connected	8 = +1R1	8 = +1R1
9 = P 24 V	9 = -1R2	9 = -1R2
10 = M 0 V	10 = P encoder	10 = P encoder
	11 = B	11 = B
	12 = B*	12 = B*
	13 = R*	13 = data*
	14 = D	14 = clock*
	15 = M sense	15 = M sense
	16 = P sense	16 = P sense
	17 = not connected	17 = not connected

### 5.4.6.5 Connecting the signal line for a motor with forced ventilation

#### Connecting the signal cable on a motor with forced ventilation up to shaft height 100

Note the following information regarding connections:

- Use only cables that comply with the installation regulations.
- Signal lines must not be subjected to excessive tensile stress.

<b>⚠ CAUTION</b>
<b>Danger of injury caused by the unintentional starting of the fan</b>
If the fan starts in the dismantled state, it can cause injuries.
<ul style="list-style-type: none"><li>• Disconnect the fan from the line supply before you dismantle it.</li></ul>

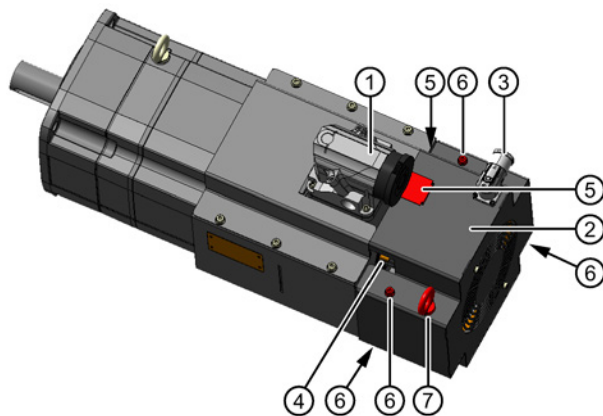

- 1 Motor power connector, e.g. size 3
- 2 Fan cover
- 3 Connection plug of the fan
- 4 Signal connector on the encoder
- 5 Sealing caps of the cable gland
- 6 4 hexagon socket-head screws with washer for fastening the fan cover
- 7 Lifting eyebolt

Figure 5-11 Forced ventilation parts



### Procedure

➔ 1.  
2.

1. Remove the 4 screws (6) of the fan cover (2) and the lifting eyes (7).

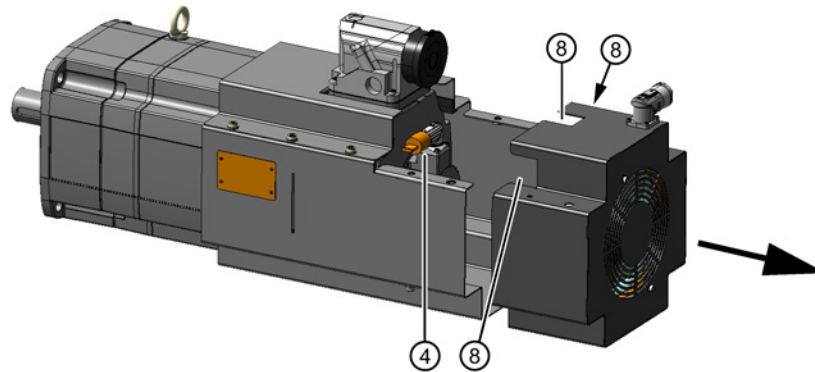

- 4 Signal connector on the encoder
- 8 3 cable glands on the fan cover

2. Remove the fan cover (2).
3. Align the signal connector (4), at 90° to the motor axis left or right.
4. Connect the signal connector (4).
5. Close the superfluous cable glands (8) with the sealing caps (5).
6. Mount the fan cover (2) with the screws (6) (tightening torque 9 Nm). Secure all screw connections against autonomous loosening, e.g. with Loctite 243. Reattach any lifting eyes.

To remove the fan cover and connect the signal connector when the motor is installed, you require a minimum clearance of 125 mm.



You have connected the signal cable.

### Connecting the signal line for a motor with external fan for SH 130

Note the following information regarding connections:

- Use only cables that comply with the installation regulations.
- Signal lines must not be subjected to excessive tensile stress.

#### **! CAUTION**

#### **Danger of injury caused by the unintentional starting of the fan**

If the fan starts in the dismantled state, it can cause injuries.

- Disconnect the fan from the line supply before you dismantle it.

### Note

Together with a second person, connect the signal connector.

**Requirement**

To dismantle the fan and the adapter flange, you require a minimum clearance of 65 mm.

**Procedure**

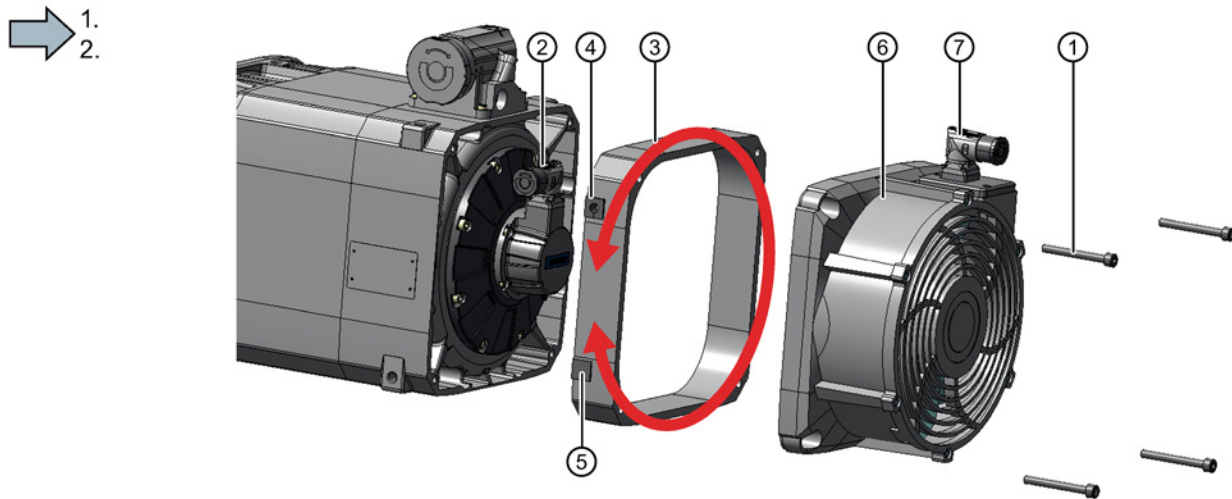

- 1 Four screws for fastening the adapter flange and the fan
- 2 Signal connector on the encoder
- 3 Adapter flange, each can be rotated through 90°.
- 4 Cable sleeve
- 5 Rubber seal (instead of a cable sleeve)
- 6 Fan
- 7 Fan connector

Figure 5-12 Connection of the signal connector to the external fan

1. Remove the two lower screws of the fan and the adapter flange.
2. Remove the two upper screws of the fan and the adapter flange. A second person holds the fan and the adapter flange when removing the fan.
3. Align the signal connector at 90° to the motor axis left or right (possible only for encoder code letter K, L, N and M).
4. Connect the signal line to the signal connector.
5. Remove the cable sleeve unit from the adapter flange.
6. Feed the signal line through the cable sleeve.

**Note**

Always attach the cable sleeve as mechanical protection.

7. Turn the adapter flange so that the signal line has the shortest path from the fan. The openings for the cable sleeves must point to the motor.

8. Push the signal line with the cable sleeve into the appropriate cutout on the adapter flange. Seal the other opening with the rubber seal.
9. Together with a second person, screw the adapter flange and the fan onto the motor housing. Tightening torque: 24 Nm  
Secure the screw connection against autonomous loosening, e.g. with Loctite 243.

**NOTICE****Damage to the line and the fan**

A signal line that is too long within the fan can damage the fan or the line itself.

- Route the signal line so it has the shortest path from the fan.
- Refrain from inserting an excessively long signal line into the fan subsequently.





You have connected the signal line.



# Commissioning

## 6.1 Safety instructions

 <b>WARNING</b>
<b>Danger to life as a result of hazardous voltages when connected to inadequately grounded line supplies</b>
Connecting a motor to an inadequately grounded line supply can result in death, severe injury and damage to the motor if a fault occurs.
<ul style="list-style-type: none"><li>• Connect motors, as part of the drive system, to TN and TT line supplies with a grounded neutral point or to IT line supplies.</li><li>• Ensure that the SINAMICS devices and motors are compatible with the residual current device according to EN 61800-5-1 before you connect the devices and motors to the line supply using residual current devices (RCDs).</li><li>• For line supplies with grounded line conductor, e.g. TT line supplies, use an isolating transformer with grounded neutral point (on the secondary side) between the line supply and the drive system, so that the motor insulation is not overstressed.</li><li>• When connected to IT line supplies, a monitoring device must signal the first fault between an active part and ground. Eliminate this fault immediately.</li></ul>

 <b>WARNING</b>
<b>Danger to life due to high touch voltages for brake cables</b>
For motor cables with integrated brake cable, when the motor is operated, the motor can charge the brake cable up to hazardous voltage levels. Coming into contact with the conductors or the shield of the brake cable can result in death or serious injury.
<ul style="list-style-type: none"><li>• Use motor cables with separate, shielded brake cables and connect the shield of the brake cable at both ends.</li></ul>

 **WARNING**

**Danger to life caused by dangerous voltage while testing the insulation resistance**

During the measurement and immediately afterward, high voltages can be present at the terminals that can cause death or severe injury as result of an electric shock.

Contact with live parts causes electric shocks.

- Work on power installations must only be performed by qualified personnel.
- Before measuring the insulation resistance, read the manual for the insulation resistance meter you are going to use.
- Never touch the terminals when making measurements or immediately after the measurement.
- Check the connected supply feeder cables to ensure that the line supply voltage cannot be connected.

 **WARNING**

**Danger to life due to unintentional starting of the drive unit**

Unintentional starting of the drive unit can cause death or severe injury.

- Make sure that the drive unit cannot be started accidentally.
- Post a warning notice to this effect at the point where the switch is located.

 **WARNING**

**Danger to life caused by machine movement and loose objects**

Machine movement and loose objects that can fall out or be ejected can cause death or severe injury.

- Ensure that the machine has been completely installed and all of the setting work completed.
- Ensure that nobody is at risk when the machine is switched on.
- Before switching on, check that there are no loose objects in or on the motor that can fall or be flung off.
- Before switching on, check that all safety guard covers are installed and all safety equipment functions correctly.

 **CAUTION**

**Burns as a result of touching hot surfaces**

In operation, the motor enclosure can reach high temperatures, which can cause burns if touched.

- Do not touch any hot surfaces.
- Allow the motor to cool down before starting any work.
- Use the appropriate personnel protective equipment, e.g. gloves.

**NOTICE**

**Thermal damage to temperature-sensitive parts**

Some parts of the frame of electric motors can reach temperatures that exceed 100° C. If temperature-sensitive parts, e.g. electric cables or electronic components, come into contact with hot surfaces, these parts could be damaged.

- Ensure that no temperature-sensitive parts are in contact with hot surfaces.

**NOTICE**

**Motor damage when the maximum speed is exceeded**

The maximum speed  $n_{\max}$  is the highest permissible operating speed. The maximum speed is specified on the rating plate.

Impermissible speeds can cause damage to the motor.

- Ensure that the maximum permissible speed is not exceeded. Realize this using a suitable control system or activate the speed monitoring function in the drive.

**NOTICE**

**Motor damage caused by uneven running or abnormal noise**

The motor can be damaged by improper handling during transport, storage or installation. If a damaged motor is operated, this can damage the winding or bearings and could even destroy the system.

- In case of uneven running or abnormal noise, switch off the motor.
- Identify the cause.

**NOTICE**

**Premature wear of the motor holding brake when operated outside its permissible voltage range**

Operating the motor holding brake outside its permissible voltage range at the motor connection will damage the brake.

- Ensure that the motor holding brake is only operated within its permissible voltage range.

## 6.2 Checklists for commissioning

**Note**

**Required checks**

The lists below do not purport to be complete. It may be necessary to perform additional checks and tests in accordance with the situation specific to the particular installation site.

Before commissioning the system, check that it is properly installed and connected.

Commission the drive system according to the operating instructions of the converter or inverter being used.

### Checklists for commissioning 1FT7 motors

Thoroughly familiarize yourself with the safety instructions and observe the checklists below before starting any work.

Table 6- 1 Checklist (1) - general checks

Check	OK
Are all of the necessary components of the configured drive line-up available, correctly dimensioned, installed and connected?	
Are the manufacturer's documentation for the system components (e.g. drive system, encoder, brake, cooling system) and the "SIMOTICS S-1FT7 servo motors" Configuration Manual available?	
If the 1FT7 motor is operated on the SINAMICS S120 drive system: Is the following, current SINAMICS documentation available? <ul style="list-style-type: none"> <li>• SINAMICS S120 Commissioning Manual</li> <li>• Getting Started S120</li> <li>• S120 Function Manual</li> <li>• S120/150 List Manual</li> </ul>	
If the 1FT7 motor is operated on the SINAMICS S120 drive system: Was the Chapter "Checklists for commissioning SINAMICS S" in the SINAMICS S120 Commissioning Manual carefully observed?	
Is the motor type to be commissioned known? (e.g. 1FT7 ___ - ___ - ___)	
Are the environmental conditions in the permissible range?	



Table 6- 2 Checklist (2) - checks regarding the mechanical system

<b>Check</b>	<b>OK</b>
Have all touch protection measures for moving and live parts been fitted and are they functional?	
Has the motor been correctly mounted and aligned?	
Can you rotate the rotor without it touching the stator?	
Have all fastening screws, fastening elements, and electrical connections been tightened with the prescribed torques and properly attached?	
Do the operating conditions correspond to the data specified on the rating plate?	
Do the output elements have the correct setting conditions according to type? Examples: <ul style="list-style-type: none"> <li>• Have the couplings been aligned and balanced?</li> <li>• Has the belt drive tension been correctly adjusted?</li> <li>• Have the gear tooth flank and gear tooth tip play as well as radial play been correctly adjusted for geared outputs?</li> </ul>	

Table 6- 3 Checklist (3) - checks regarding the electrical system

<b>Check</b>	<b>OK</b>
Has the motor been connected so that it rotates in the specified direction?	
Have the minimum insulation resistance values been maintained?	
Have the grounding and equipotential bonding connections been correctly established?	
Is the specified limit speed $n_{max}$ maintained during the operation on the converter?	

Table 6- 4 Checklist (4) - Monitoring equipment checks

<b>Check</b>	<b>OK</b>
Has it been ensured that speeds higher than the maximum speed $n_{max}$ cannot be reached?	
Have all supplementary motor monitoring devices been correctly connected and are they working properly?	

Table 6- 5 Checklist (5) - Cooling system checks

Check	OK
<p><b>Water cooling</b></p> <p>Has the cooling water supply been connected and is it ready for operation? Is the cooling water circulating correctly? (flow rate, temperature)</p>	
<p><b>Forced ventilation</b></p> <p>Have you checked all safety-related and functionally relevant details? Examples:</p> <ul style="list-style-type: none"> <li>• Have you compared the data of the external cooling unit with the connection data? Connect the external cooling unit only if the supply data does not result in an overload condition.</li> <li>• Has the forced ventilation unit, including accessories, been correctly installed, e.g. fitting of the protective conductor?</li> <li>• Are the mechanical installation and electrical installation of the safety-related components correct? This includes the installation of the motor circuit breaker and the fitting of protective grilles, for example.</li> <li>• Are the cable entry glands correctly fitted and tight?</li> <li>• Are the fan air intake and the area around the fan blades free of foreign bodies?</li> <li>• Is the fan rotation direction correct? An arrow is stamped on the fan rating plate. This arrow indicates the correct direction of rotation of the fan. An arrow is also marked on the fan blades. When the fan starts, you can check the direction of rotation using the arrows. The fan is functioning correctly if the direction of rotation of the blades matches the direction of the arrow on the fan rating plate.</li> </ul>	
Can the motor only be switched on when the fan is running?	

Table 6- 6 Checklist (6) - Checks regarding the optional brake

Check	OK
Is the brake open when the operating voltage is applied?	
Does the brake open and close correctly?	

## 6.3 Commissioning procedure

### Procedure



1.  
2.

- Ensure that the frequency converter is correctly parameterized.
- Commission the motor with an appropriate commissioning tool, e.g. "Drive ES" or "STARTER".
- Follow the steps of the commissioning tool.



You have commissioned the motor.

### Switching off

- Switch off the motor at the frequency converter.

## 6.4 Switching on and switching off

---

### Note

#### EMERGENCY OFF

To avoid accidents, inform yourself about the EMERGENCY OFF function before you switch on the system.

---

The motor is switched on and off using the frequency converter.

- For more information on this topic, see the chapter in the Operating Instructions for the converter.

### Before switching on

- Ensure that the frequency converter is correctly parameterized.
- Check whether sufficient heat is dissipated from the motor.



1.  
2.

### Switching on

1. Switch on the motor at the frequency converter.
2. Observe any uneven running and abnormal noise of the motor.
3. Check the function of the safety equipment.
4. Check whether the motor reaches the required parameters



You have switched on the motor.

### Switching off

- Switch off the motor at the frequency converter.



## 7.1 Safety instructions

 <b>WARNING</b>
<b>Do not remove covers when the motor is running</b> Rotating or live parts are dangerous. Death, serious injury, or material damage can result if the required covers are removed. All covers that prevent personnel from coming into contact with active or rotating parts, ensure compliance with the required degree of protection, or ensure proper air guidance and, in turn, effective cooling must not be opened/removed during operation.

 <b>WARNING</b>
<b>Faults in operation</b> Deviations from normal operation (e.g. increased power consumption, temperature, or vibration levels, unusual noises or smells, tripping of monitoring equipment, etc.) indicate that the machine is not functioning properly. This can cause faults that can result in eventual or immediate death, severe personal injury, or material damage. Immediately inform the maintenance personnel. If in doubt, shut down the motor immediately, taking into account the plant-specific safety regulations.

 <b>CAUTION</b>
<b>Danger of burns</b> The temperature of certain parts of the motor can exceed 100 °C. Physical contact can cause serious burns. Check the temperature of the parts before touching them and take appropriate protective measures if necessary.

## 7.2 Switching on and switching off

---

### Note

#### EMERGENCY OFF

To avoid accidents, inform yourself about the EMERGENCY OFF function before you switch on the system.

---

The motor is switched on and off using the frequency converter.

- For more information, see the appropriate chapter in these Operating Instructions.

#### Before switching on

- Ensure that the frequency converter is correctly parameterized.
- Check whether sufficient heat is dissipated from the motor.

#### Switching on

1. Switch on the motor at the frequency converter.
2. Observe any uneven running and abnormal noise of the motor.
3. Check the function of the motor cooling system.
4. Check the function of the safety equipment.
5. Check whether the motor reaches the required parameters

You have switched on the motor.

#### Switching off

- Switch off the motor at the frequency converter.



1.  
2.



## 7.3 During operation

### Operation

While the motor is operating, ensure that the specified parameters are maintained.

Make sure that:

- The power consumption is in the specified range
- Cooling is ensured
  - With water cooling: Check the liquid level, inlet temperature of the coolant, and coolant circulation.
  - With forced ventilation: Check that the heat can dissipate freely.
- There is no abnormal motor noise

- The motor does not overheat
- If available, the sealing air intake functions

---

**Note**

**Observe the maintenance intervals**

Service the motor at the prescribed maintenance intervals. (see Chapter "Maintenance and inspection intervals (Page 118)"

---

## 7.4 Stoppages

On motors with water cooling:

- Shut off the coolant supply.

<b>NOTICE</b>
<b>Damage due to improper storage</b>
The motor can be damaged if it is not stored properly.
<ul style="list-style-type: none"><li>• If the motor is not operational for longer periods of time, preserve it by means of anti-corrosion protection and ensure that it remains dry (e.g. appropriate drying agents).</li><li>• When recommissioning the motor after it has been out of service for a longer period of time, carry out the measures recommended in Chapter "Commissioning".</li></ul>
<ul style="list-style-type: none"><li>• Store the motor according to the instructions in Chapter "Storage (Page 53)."</li><li>• Refer to Section "Commissioning (Page 101)" before recommissioning the motor.</li></ul>





## Faults and their rectification

---

### Note

#### Damage to the machine caused by faults

Correct the cause of the fault as specified in the remedial measures. Repair any damage to the machine/motor.

---

### Note

When operating the motor with a converter, refer also to the Operating Instructions of the frequency converter if electrical faults occur.

---

If there are deviations from normal operation or if faults occur, initially proceed according to the following list. While doing so, observe the relevant chapters in the documentation associated with the components of the complete drive system.

Even in test operation, never disable protective functions or devices.

Table 8- 1 Possible faults

Fault	Cause of fault (see key table)																		
	A	B	C	D	E	F	G	H	I	J	K	L	M	N	O	P	Q	R	S
Motor does not start up	A	B																	
Motor starts up slowly	A		C			F													
Humming noise when starting			C			F													
Humming noise during operation	A		C			F													
Overheating during no-load operation				D		G	H	I											
Overheating when under load	A		C			G	H	I											
Overheating of individual winding sections						F													
Uneven running										J	K								
Grinding sound, running noise												L							
Radial vibrations													M	N	O	P		R	
Axial vibrations															O		Q	R	
Water is leaking																			S

Table 8- 2 Key to causes of faults and remedial measures

No.	Cause of fault	Remedial measures
A	Overload	Reduce load
B	Interruption of a phase in the supply cable / motor winding	Check the frequency converter and supply cables/measure the winding resistances and insulation resistances, repair after consultation with manufacturer
	Incorrect parameterization or adjustment of the encoder	Parameterize or adjust the drive correctly
C	Interruption of a phase in the supply cable after switching on	Check the frequency converter and supply cables, check the winding resistances
	Rotor partially demagnetized	Replace the motor
	Incorrect adjustment of the encoder	Adjust the encoder
D	Converter output voltage too high, frequency too low	Check the settings on the frequency converter, perform automatic motor identification
F	Winding short-circuit or phase short-circuit in stator winding	Measure the winding resistances and insulation resistances, repair after consultation with manufacturer
G	Cooling water not connected / switched off	Check cooling water connection, switch on cooling water
	Water connection/pipes defective	Locate leaks and seal as necessary, or consult the manufacturer
H	Cooling water flow rate too low	Increase cooling water flow rate
	Inlet temperature too high	Set correct inlet temperature
I	Heat dissipation impeded by deposits	Clean the surface of the drives and ensure that the cooling air can flow in and out unimpeded
	Cooling air inlet and/or outlet is blocked by foreign bodies	Remove the blockage and ensure that the cooling air can flow in and out unimpeded
	Fan motor does not start up	Make sure that the fan motor works properly
	Thermally insulated mounting	Do not mount the motor in a thermally insulated manner
	Gear unit not considered	Redimension the motor, adjust the parameters
J	Insufficient shielding for motor and/or encoder cable	Check the shielding and grounding
K	Drive controller gain too high	Adjust the controller
L	Rotating parts are grinding	Determine cause and adjust parts
	Foreign bodies in the motor	Send to manufacturer for repair
	Bearing damage	Send to manufacturer for repair
M	Rotor not balanced	Decouple rotor and rebalance
N	Rotor out of true, shaft bent	Consult the manufacturer
O	Poor alignment	Align motor unit, check coupling
P	Coupled machine not balanced	Re-balance coupled machine
Q	Shocks from coupled machine	Check coupled machine
R	Imbalance originating from gearing	Adjust/repair gearing
S	Cooling water pipes / water connection defective	Locate leaks and seal as necessary, or consult the manufacturer

If the fault still cannot be resolved after taking the measures stated above, please contact the manufacturer or the Siemens Service Center.

## 9.1 Safety instructions

If you have any questions, please contact the manufacturer, quoting the machine type and serial number.

### **WARNING**

#### **Danger to life when live parts are touched**

Death or serious injury can result when live parts are touched.

- Only work on electrical equipment if you are appropriately qualified.
- Always comply with the local national safety regulations when working on electrical equipment.

Generally, six steps apply when establishing safety:

1. Prepare for shutdown and notify all those who will be affected by the procedure.
2. Disconnect the machine from the power supply.
  - Switch off the machine.
  - Wait until the discharge time specified on the warning labels has elapsed.
  - Check that it really de-energized, from phase to phase and phase to protective conductor.
  - Check that every auxiliary circuit is de-energized.
  - Ensure that the motors cannot move.
3. Secure SIMOTICS S motors against unintentional movements that generate a voltage at the terminals.
4. Identify all other dangerous energy sources, e.g. compressed air, hydraulic systems or water.
5. Isolate or neutralize all hazardous energy sources, for example by closing switches, grounding or short-circuiting, or closing valves.
6. Take measures to prevent reconnection of the energy sources.
7. Make sure that the machine is completely locked ... and that you have the right machine.

After you have completed the work, restore operational readiness by performing the above steps in the reverse order.

 **WARNING**

**Danger to life due to slipping on leaked oil**

Leaked oil can result in slipping or falling and cause death or severe injury.

- Prevent oil from leaking
- Absorb leaked oil immediately with a binding agent for oil or similar.
- Rough up the hazardous location.
- Mark the hazardous location.

 **WARNING**

**Danger to life due to unintentional starting of the drive unit**

Unintentional starting of the drive unit can cause death or severe injury.

- Make sure that the drive unit cannot be started accidentally.
- Post a warning notice to this effect at the point where the switch is located.

 **CAUTION**

**Burning hazard caused by hot surfaces**

Some parts of the frame of electrical machines can reach temperatures in excess of 100°C. Touching components when the machine is in operation can cause burns.

- Do not touch frame parts while the machine is in operation or immediately after machine operation.
- Allow frame parts to cool off before starting any work.

 **CAUTION**

**Danger of scalding from the hot oil exiting the unit**

Exiting hot oil can cause burns.

- Before starting any work, wait until the oil has cooled down to below 30° C.

 **CAUTION**

**Chemical burns and irritations caused by chemical cleaning agents**

Chemical cleaning agents can be caustic or emit dangerous fumes. If these come into contact with skin or if you inhale the fumes, this can cause injuries (e.g. chemical burns on the skin or respiratory passages, or skin irritation).

- During cleaning, make sure that appropriate methods of extracting fumes are in place and that you wear the appropriate protective gear (e.g. gloves, goggles, face masks).
- If using chemical cleaning agents, observe the instructions and any warnings provided in the relevant safety data sheet. Chemical cleaning agents must be suitable for use with the machine's components, particularly where plastic components are concerned.

**⚠ CAUTION****Injuries caused by stirred-up foreign bodies and dust when working with compressed air**

When you clean using compressed air, this can stir up dust, metal chips and cleaning agents, and so cause injuries.

- When cleaning using compressed air, make sure you use suitable extraction equipment and wear protective equipment (safety goggles, protective suit, etc.).

**⚠ WARNING****Danger to life when lifting and transporting**

Incorrect lifting and transport operations, devices and equipment that are unsuitable or damaged can result in death, severe injury and/or damage to property.

- Lifting devices, ground conveyors, and load suspension equipment must comply with requirements.
- The maximum capacity of the lifting equipment and the load suspension device must correspond to the weight of the motor (see the rating plate).
- Do not attach any additional loads to the lifting equipment.
- To hoist the motor, use suitable cable-guidance or spreading equipment, particularly if the motor is equipped with built-on assemblies.
- The motor must not be lifted or transported by means of the power connector or signal connector.
- Do not stand in the slewing range of hoisting gear or under suspended loads.

**⚠ WARNING****Danger to life through incorrect or unused lifting points**

Due to incorrect or unused lifting points, the motor can fall and cause death, severe injury and/or damage to property.

- Lift and transport large motors using the eyebolts screwed on to the end shields.
- Completely screw in the eyebolts and tighten by hand (approx. 8 Nm).
- Do not use bent or damaged eyebolts.
- Only use eyebolts with laminated fiber washers.
- Loads applied transversely to the plane of the eyebolts are not permitted.

**⚠ WARNING****Danger of injury due to suspended loads**

While being transported, the motor can cause injury by moving.

- Only use perfectly functioning hoisting and load suspension equipment dimensioned to carry the motor load.
- Do not stand under suspended loads or in their slewing range.
- When placing down the motor, ensure that it cannot roll.

## 9.2 Inspection and maintenance

### 9.2.1 Maintenance and inspection intervals

#### General

Carry out maintenance work, inspections and revisions at regular intervals in order to be able to identify faults at an early stage and remove them.

---

#### Note

##### Inspection if there are faults or unusual conditions

Unusual conditions or faults that represent overstressing of the motor, e.g. overload or short-circuit, can result in consequential damage to the machine.

Immediately perform an inspection when faults or exceptional conditions occur.

---

#### Maintenance measures, inspection/maintenance times intervals

The maintenance intervals depend on the operating conditions.

- Adapt the maintenance intervals to match the local conditions, such as pollution/dirt, switching frequency, load, etc.
- Perform the following maintenance measures as specified in the table.

Maintenance and repair of the motor can be performed by Siemens Service Centers throughout the world.

Contact your personal Siemens contact if you require this service.

<b>NOTICE</b>
<b>Improper maintenance</b>
Service and maintenance must only be performed by properly authorized qualified personnel.
Only use original SIEMENS parts.

Table 9- 1 Maintenance measures after operating times or intervals

Operating times and intervals	Measure
<b>Operation</b>	
Daily; if possible, more frequently during operation.	Monitor and check the motor for unusual noise, vibrations, and changes.
After approx. 10,000 operating hours, at the latest after two years	If oil-lubricated, replace the radial shaft seal rings
As required, or after 25,000 operating hours	Replace the motor bearings

## 9.2.2 Cleaning

 <b>WARNING</b>
<b>Danger to life when cleaning due to failure to observe the protection class</b>
When cleaning, especially with high-pressure cleaning equipment, water can enter energized parts and cause an electric shock.
<ul style="list-style-type: none"><li>• Clean the motor in a manner appropriate for its protection class.</li><li>• Avoid pressurized water on connectors, terminal boxes, and other live parts.</li></ul>

 <b>CAUTION</b>
<b>Burning hazard caused by hot surfaces</b>
Some parts of the frame of electrical machines can reach temperatures in excess of 100° C. Touching components when the machine is in operation can cause burns.
<ul style="list-style-type: none"><li>• Do not touch frame parts while the machine is in operation or immediately after machine operation.</li><li>• Allow frame parts to cool off before starting any work.</li></ul>

 <b>CAUTION</b>
<b>Chemical burns and irritations caused by chemical cleaning agents</b>
Chemical cleaning agents can be caustic or emit dangerous fumes. If these come into contact with skin or if you inhale the fumes, this can cause injuries, e.g. chemical burns on the skin or respiratory passages, or skin irritation.
<ul style="list-style-type: none"><li>• During cleaning, make sure that appropriate methods of extracting fumes are in place and that you wear the appropriate protective gear (e.g. gloves, goggles, face masks).</li><li>• If using chemical cleaning agents, observe the instructions and any warnings provided in the relevant safety data sheet. Chemical cleaning agents must be suitable for use with the machine's components, particularly where plastic components are concerned.</li></ul>

Clean the motor of dust and dirt as required. In this way, you ensure adequate heat dissipation.

### Cleaning motors with option N16 or N40

Clean the motor in accordance with the cleaning recommendation in the appendix. (see ECOLAB cleaning recommendation (Page 132))

### 9.2.3 Bearing replacement interval

The bearings are subject to wear and must be replaced after a defined number of operating hours.

For average load levels, the bearings must be replaced after approx. 25,000 hours.

Bearing replacement intervals can be extended if the motor is operated under favorable conditions, e.g. low average speeds, low radial forces (cantilever forces), vibration load.

---

#### Note

##### Harsh operating conditions

If the motor is subject to harsh operating conditions (e.g. continuous operation at  $n_{max}$ , high vibration/shock loads, frequent reversing duty etc.), the bearing replacement intervals  $t_{LW}$  can decrease by up to 50%.

---

## 9.3 Repair

The Siemens Service Center Bad Neustadt and other regional service sites throughout the world can handle or organize the maintenance/repair of the motors.

Contact your regional Siemens contact if you require this service.

### Note regarding encoder replacement

You can replace a defective encoder.

The procedure for replacing an encoder is described in Service manual replacing an encoder (<https://support.industry.siemens.com/cs/document/99457853/encoder-replacement-in-1fk7-g2-and-1ft7?dti=0&dl=en&pnid=13308&lc=de-WW>).



## Decommissioning and disposal

### 10.1 Safety instructions

#### Removing the motor from the machine

 **WARNING**

**Danger to life when live parts are touched**

Death or serious injury can result when live parts are touched.

- Only work on electrical equipment if you are appropriately qualified.
- Always comply with the local national safety regulations when working on electrical equipment.

Generally, six steps apply when establishing safety:

1. Prepare for shutdown and notify all those who will be affected by the procedure.
2. Disconnect the machine from the power supply.
  - Switch off the machine.
  - Wait until the discharge time specified on the warning labels has elapsed.
  - Check that it really de-energized, from phase to phase and phase to protective conductor.
  - Check that every auxiliary circuit is de-energized.
  - Ensure that the motors cannot move.
3. Secure SIMOTICS S motors against unintentional movements that generate a voltage at the terminals.
4. Identify all other dangerous energy sources, e.g. compressed air, hydraulic systems or water.
5. Isolate or neutralize all hazardous energy sources, for example by closing switches, grounding or short-circuiting, or closing valves.
6. Take measures to prevent reconnection of the energy sources.
7. Make sure that the machine is completely locked ... and that you have the right machine.

After you have completed the work, restore operational readiness by performing the above steps in the reverse order.

 **WARNING**

**Danger to life due to slipping on leaked oil**

Leaked oil can result in slipping or falling and cause death or severe injury.

- Prevent oil from leaking
- Absorb leaked oil immediately with a binding agent for oil or similar.
- Rough up the hazardous location.
- Mark the hazardous location.

 **CAUTION**

**Burning hazard caused by hot surfaces**

Some parts of the frame of electrical machines can reach temperatures in excess of 100° C. Touching components when the machine is in operation can cause burns.

- Do not touch frame parts while the machine is in operation or immediately after machine operation.
- Allow frame parts to cool off before starting any work.

 **CAUTION**

**Danger of scalding from the hot oil exiting the unit**

Exiting hot oil can cause burns.

- Before starting any work, wait until the oil has cooled down to below 30° C.

 **CAUTION**

**Chemical burns and irritations caused by chemical cleaning agents**

Chemical cleaning agents can be caustic or emit dangerous fumes. If these come into contact with skin or if you inhale the fumes, this can cause injuries, e.g. chemical burns on the skin or respiratory passages, or skin irritation.

- During cleaning, make sure that appropriate methods of extracting fumes are in place and that you wear the appropriate protective gear (e.g. gloves, goggles, face masks).
- If using chemical cleaning agents, observe the instructions and any warnings provided in the relevant safety data sheet. Chemical cleaning agents must be suitable for use with the machine's components, particularly where plastic components are concerned.

 **WARNING**

**Danger to life caused by falling machine parts**

The machine partially comprises heavy individual components. When removing the machine, these components can fall. This can result in death, serious injury or material damage.

- Secure the machine components that are being released so that they cannot fall.

 **WARNING****Injury as a result of suspended loads**

When being dismantled and transported, the motor can cause injury as a result of its movement.

- Only use perfectly functioning hoisting and load suspension equipment dimensioned to carry the motor load.
- Pay careful attention to possible movement when the motor is released.
- Do not stand under suspended loads or in their slewing range.
- When placing down the motor, ensure that it cannot roll.

 **CAUTION****Injuries caused by liquids when draining and environmental pollution**

When draining, liquids can cause injuries, such as burns, chemical burns, irritation. Spilt oil can make floor surfaces slippery and pollute the environment.

- Allow the liquid to cool down.
- Use a sufficiently large collection container.
- Avoid liquids coming into contact with the skin. Wear suitable personnel protection equipment, e.g. protective eyewear, gloves.
- Have materials on hand to soak up leaked liquids and prevent areas from being slippery.

## Dismantling the motor

---

**Note**

The rotor in a motor containing permanent magnets must only be removed by the manufacturer.

- Contact the Siemens Service Center.
-

## 10.2 Decommissioning

### 10.2.1 Preparing for dismantling

The dismantling of the motor must be performed and/or supervised by qualified personnel with appropriate expert knowledge.

Contact a certified waste disposal organization in your vicinity. Clarify what is expected in terms of the quality of disassembling the motor and provision of the components.

#### Removing the motor from the machine



1. Disconnect all electrical connections.
2. Remove all liquids such as oil, water.
3. Remove all supply lines.
4. Remove the fixing elements from the motor.
5. Transport the motor to a suitable location for storage and dismantling.



### 10.2.2 Disassembling the motor

---

#### Note

The rotor in a motor containing permanent magnets must only be removed by the manufacturer.

Contact the Siemens Service Center.

---

## 10.3 Disposal

Protecting the environment and preserving its resources are corporate goals of the highest priority for Siemens. Our worldwide environmental management system according to ISO 14001 ensures compliance with legislation and sets high standards in this regard. Environmentally friendly design, technical safety and health protection are always firm goals, even at the product development stage.

Recommendations for the environmentally friendly disposal of the machine and its components are given in the following chapter.

- Be sure to comply with local disposal regulations.
- Separate the housing parts, shafts and roller bearings of the motor according to their material.
- Dispose of the parts in accordance with the applicable legal regulations.
- Dispose of the packaging material in accordance with the applicable legal regulations.

## Components

- Sort the components for recycling according to whether they are:
  - Electronics waste, e.g. encoder electronics
  - Iron to be recycled
  - Aluminum
  - Non-ferrous metal, e.g. motor windings
  - Insulating materials

## Process materials and chemicals

- Sort the process materials and chemicals for recycling according to whether they are:
  - Oil
  - Dispose of the spent oil as special waste in accordance with the spent oil ordinance
  - Grease
  - Solvents
  - Cleaner solvent
  - Paint residues
- Do not mix solvents, cleaner solvents and paint residues.

## Disposing of permanent magnets

Permanent magnets must be demagnetized prior to disposal. This helps avoid potential hazards caused by permanent magnets during and after disposal. Permanent magnets are heated to demagnetize them.

Permanent magnets can be demagnetized in one of the following ways:

- Have a specialist disposal company thermally treat the motor.
- Hand over the motor to the manufacturer. The manufacturer can then remove and demagnetize the rotor and/or permanent magnets.

---

### Note

Rotors that have been removed but are still magnetized cannot be transported.

---

---

### Note

#### Removing the rotor

A magnetized rotor may only be removed by the manufacturer. Contact the Siemens Service Center.

---



## Technical data

The technical data for the motors with the various shaft heights is contained in the "Technical data and characteristic curves" chapter of the Configuration Manual.





# A

## Appendix

### A.1 Certificate for the "PS Premium" painting system from ECOLAB



Figure A-1 Certificate\_option\_N16\_page 1

A.1 Certificate for the "PS Premium" painting system from ECOLAB



**The certificate for the coating PS Premium based on:**

- documented test procedure for material compatibility
- defined product specification
- a standardized cleaning plan

**Test procedure**

**Soaking test:**

- Partly soaked into test mediums

**Test time :**

- 7 days

**Test contents:**

- pH-value of solutions: 1,5 – 13,0
- Ingredients:  
e.g. caustic, phosphoric acid, peroxyacetic acid, hydrogen peroxide, sodium hypochlorite, alkyl amine acetate

**Evaluation:**

- Estimation after appr. 7 days regeneration
- Estimation of degradation of coatings according to DIN EN ISO 4628-1 and estimation of decorative changing (colour and gloss level)
- Key  
(+) no changing  
(o) minor changing possible, decorative nature only  
(-) changing possible by long term use

The coating PS Premium was tested with the following products:

Alkaline and chlorinated alkaline foam cleaning products			
P3-topax 12	3%	40°C	+
P3-topax 19	5%	40°C	o
P3-topax 686	5%	40°C	+

TFC-cleaner			
P3-topactive 200	4%	40°C	+
P3-topactive 500	4%	40°C	+

Acidic foam cleaning products			
P3-topax 56	5%	40°C	+
P3-topax 58	5%	40°C	+

Disinfection products			
P3-topax 990	5%	23°C	o
P3-oxonia active 150	1%	23°C	+

DI-water			
	-	40°C	+

**Product specification:**

**P3-topax 12**  
Mild alkaline foam cleaning product

**P3-topax 19**  
Alkaline foam cleaning product

**P3-topax 686**  
Chlorinated alkaline foam cleaning product

**P3-topax 56**  
Foam cleaning product based on phosphoric acid

**P3-topax 58**  
Foam cleaning product based on organic acids

**P3-topactive 200**  
Alkaline thin film cleaner

**P3-topactive 500**  
Acidic thin film cleaner

**P3-topax 990**  
Foam disinfection product based on alkyl amine acetate

**P3-oxonia active 150**  
Disinfection product based on peroxyacetic acid and hydrogen peroxide

**DI-water**  
Deionised water

Ecolab Deutschland GmbH Reisholzer Werfstr. 38-42 D-40589 Düsseldorf

Deutsche Bank AG, Düsseldorf  
Konto 2 272 276 BLZ 300 700 10  
IBAN: DE38 3007 0010 0227 2276 00  
BIC: DEUTDE33  
UST-ID-Nr: DE 814914835  
Gesellschaft mit beschränkter Haftung Sitz: Düsseldorf  
Handelsregister: AG Düsseldorf, HRB 28757  
Vorsitzender des Aufsichtsrates: Ralf Ebel  
Geschäftsführung: Alfred Stöhr, Ralph Gichtbrock

Figure A-2 Certificate\_option\_N16\_page 2

## A.2 ECOLAB cleaning recommendation







**“Cleaning Recommendation“**  
 SIEMENS AG, Industry Sector, DT MC MF-M  
 Coating PS Premium

Cleaning & Disinfection

**EUROPE**

<p><u>Application:</u> Foam / TFC Cleaning and disinfection</p> <p><u>Specific application area:</u> Removal of residues of the Food &amp; Beverage Industry</p> <p><u>Cleaning frequency:</u> tbd</p>	<p><u>Typical residues:</u> Organic and inorganic residues</p> <p><u>General information:</u> Coating PS Premium for servomotors</p>
--	--

Cleaning Procedure & Chemicals	%	°C	min.	Notes
<p><b>Pre-rinse</b></p>  <p>Water</p>	-	40-50	tbd	Low pressure pre-rinse with water to remove rough residues.
<p><b>Foam Cleaning /Thin Film Cleaning</b></p>  <p>P3-topax .... or P3-topactive .....</p>	1-5	20-40	10 - 30	Concentration, application time and application temperature depends on foam cleaning product and TFC-product as well.  For product application please see also the information from the product data sheet
<p><b>Intermediate Rinse</b></p>  <p>Water</p>	-	40-50	tbd	Use water of drinking quality. Low pressure rinse thoroughly with fresh water of drinking quality until all product residues are removed.
<p><b>Foam Disinfection /Thin Film Disinfection</b></p>  <p>P3-topax .... or P3-topactive...</p>	1-3	RT	10-30	Concentration, application time and application temperature depends on foam disinfection product and TFC-product as well.  Use biocides safely. Always read the label and product information before use.
<p><b>Final Rinse</b></p>  <p>Water</p>	-	40-50	tbd	Use water of drinking quality. Low pressure rinse thoroughly with fresh water of drinking quality until all product residues are removed.

©11/2011, Ecolab Deutschland GmbH  
 For any assistance do not hesitate to contact your responsible Ecolab service.

 **Important additional remarks!**  
 Due to the diversity of materials and applications the information given above represents only a non binding guideline and is not intended to supersede the manufacturers specifications, limitations and recommendations. It is compulsory to follow the manufacturers limitations, especially concerning pH and temperature stability of the materials. The cleaning process should be individually optimized.

Figure A-3 ECOLAB cleaning recommendation for N16 and N40

## Glossary

### Rated torque $M_N$

Thermally permissible continuous torque in S1 duty at the rated motor speed.

### Rated speed $n_N$

The characteristic speed range for the motor is defined in the speed-torque diagram by the rated speed.

### Rated current $I_N$

RMS motor phase current for generating the particular rated torque. Specification of the RMS value of a sinusoidal current.

### DE

Drive end = Drive end of the motor

### Torque constant $k_T$ (value for a 100 K average winding temperature rise)

Quotient obtained from the static torque and stall current.

Calculation:

$$k_T = M_{0, 100\text{ K}} / I_{0, 100\text{ K}}$$

The constant applies up to approx.  $2 \cdot M_{0, 60\text{ K}}$  in the case of self-cooled motors

---

#### Note

This constant is not applicable when configuring the necessary rated and acceleration currents (motor losses!).

The steady-state load and the frictional torques must also be included in the calculation.

---

### Maximum permissible speed (mechanical) $n_{max}$ .

The maximum mechanically permissible speed is  $n_{max\ mech}$ . It is defined by the centrifugal forces and frictional forces in the bearing.

### NDE

Non-drive end = Non-drive end of the motor

### Number of poles $2p$

Number of magnetic north and south poles on the rotor.  $p$  is the number of pole pairs.

### Static torque $M_0$

Thermal limit torque at motor standstill corresponding to a utilization according to 100 K or 60 K. This can be output for an unlimited time when  $n = 0$  rpm.  $M_0$  is always greater than the rated torque  $M_N$ .

### Stall current $I_0$

Motor phase current to generate the particular stall torque ( $M_0 = k_T \cdot I_0$ ). Specification of the RMS value of a sinusoidal current.

### Winding resistance $R_{Str}$ at 20° C winding temperature

The resistance of a phase at a winding temperature of 20° C is specified. The winding is in a star connection.

# Index

## B

Bearing change interval, 120

## C

Certificates

EAC, 23

EC Declaration of Conformity, 23

UL and cUL, 23

Commissioning, 104

Connecting the water cooling system, 64

Correct usage, 21, 21

## D

Disposal, 124

DRIVE-CLiQ interface, 36, 88

## F

Forced ventilation, 40

## H

Holding brake, 45

Hotline, 7

## I

Inspection and maintenance, 115

## K

KTY, 34

## L

Lifting and transporting the motor, 49

## M

Maintenance intervals, 118

Mounting conditions, 59

## N

Noise emission, 27

## P

Pt1000, 34

## R

Rating plate, 29, 29

## S

Sealing of the motor shaft, 26

Siemens Service Center, 7

Sound pressure level, 27

## T

Target group, 5

Technical Support, 7

Thermal motor protection, 34

Tightening torques, 58

Training, 7

Transportation, 49

## V

Vibration response, 62

## W

Water cooling, 42, 62

Siemens AG  
Digital Factory  
Motion Control  
Postfach 31 80  
91050 ERLANGEN  
Germany

Subject to change without notice

For further  
information about  
SIMOTICS, scan the  
QR code.

