



# Instruction Manual

VLT<sup>®</sup> AQUA Drive FC 200

## Contents

<b>1 How to Read this Instruction Manual</b>	1-1
Copyright, Limitation of Liability and Revision Rights	1-2
Approvals	1-3
Symbols	1-3
<b>2 Safety</b>	2-1
General Warning	2-2
Before Commencing Repair Work	2-2
Special Conditions	2-2
Caution	2-2
Avoid Unintended Start	2-3
IT Line Power	2-3
Safe Stop of the Adjustable Frequency Drive (optional)	2-4
<b>3 Introduction</b>	3-1
Type Code String - Medium Power	3-1
<b>4 Mechanical Installation</b>	4-1
Before Starting	4-1
<b>5 Electrical Installation</b>	5-1
How to Connect	5-1
Line Power Wiring Overview	5-3
Motor Wiring Overview	5-10
DC Bus Connection	5-15
Brake Connection Option	5-16
Relay Connection	5-17
Electrical Installation and Control Cables	5-23
How to Test Motor and Direction of Rotation	5-25
<b>6 Commissioning and Application Examples</b>	6-1
Quick Set-up	6-1
Start/Stop	6-2
Closed-loop Wiring	6-2
Submersible Pump Application	6-3
<b>7 How to Operate the Adjustable Frequency Drive</b>	7-1
Ways of Operation	7-1
How to Operate the Graphical LCP (GLCP)	7-1

How to Operate the Numeric LCP (NLCP)	7-5
Tips and Tricks	7-9
<b>8 How to Program the Adjustable Frequency Drive</b>	<b>8-1</b>
How to Program	8-1
Commonly Used Parameters - Explanations	8-6
Main Menu	8-6
Parameter Options	8-44
Default Settings	8-44
Operation/Display 0-**	8-45
Load/Motor 1-**	8-47
Brakes 2-**	8-49
Reference / Ramps 3-**	8-50
Limits / Warnings 4-**	8-51
Digital In/Out 5-**	8-52
Analog In/Out 6-**	8-53
Comm. and Options 8-**	8-54
Profibus 9-**	8-55
CAN Fieldbus 10-**	8-56
Smart Logic 13-**	8-57
Special Functions 14-**	8-58
Adj. Freq. Drive Information 15-**	8-59
Data Readouts 16-**	8-61
Data Readouts 2 18-**	8-63
Adj. Freq. Drive Closed-loop 20-**	8-64
Ext. Closed-loop 21-**	8-65
Application Functions 22-**	8-67
Timed Actions 23-**	8-69
Cascade Controller 25-**	8-70
Analog I/O Option MCB 109 26-**	8-72
Water Application Functions 29-**	8-75
Bypass Option 31-**	8-76
<b>9 Troubleshooting</b>	<b>9-1</b>
Fault Messages	9-4
<b>10 Specifications</b>	<b>10-1</b>
General Specifications	10-1
Special Conditions	10-17

**11 Index** ..... 11-1



## 1 How to Read this Instruction Manual

1

# VLT AQUA Drive FC 200 Series Software version: 1.33



This guide can be used with all FC 200 adjustable frequency drives  
with software version 1.33 or later.

The current software version number can be read from  
par. 15-43 *Software Version*.

**1****1.1.1 Copyright, Limitation of Liability and Revision Rights**

This publication contains information proprietary to Danfoss. By accepting and using this manual, the user agrees that the information contained herein will be used solely for operating equipment from Danfoss or equipment from other vendors provided that such equipment is intended for communication with Danfoss equipment over a serial communication link. This publication is protected under the copyright laws of Denmark and most other countries.

Danfoss does not warrant that a software program produced according to the guidelines provided in this manual will function properly in every physical, hardware or software environment.

Although Danfoss has tested and reviewed the documentation within this manual, Danfoss makes no warranty or representation, neither expressed nor implied, with respect to this documentation, including its quality, performance, or fitness for a particular purpose.

In no event shall Danfoss be liable for direct, indirect, special, incidental, or consequential damages arising out of the use, or the inability to use information contained in this manual, even if advised of the possibility of such damages. In particular, Danfoss is not responsible for any costs, including but not limited to those incurred as a result of lost profits or revenue, loss or damage of equipment, loss of computer programs, loss of data, the costs to substitute these, or any claims by third parties.

Danfoss reserves the right to revise this publication at any time and to make changes to its contents without prior notice or any obligation to notify former or present users of such revisions or changes.

**1.1.2 Available Literature for VLT® AQUA DriveFC 200**

- VLT® AQUA Drive Instruction Manual MG.20.Mx.yy provides the necessary information for getting the drive up and running.
- VLT® AQUA Drive High Power Instruction Manual MG.20.Px.yy provides the necessary information for getting the HP drive up and running.
- VLT® AQUA Drive Design Guide MG.20.Nx.yy contains all the technical information about the drive and customer design and applications.
- VLT® AQUA Drive Programming Guide MN.20.Ox.yy provides information on how to program and includes complete parameter descriptions.
- VLT® AQUA Drive FC 200 Profibus MG.33.Cx.yy
- VLT® AQUA Drive FC 200 DeviceNet MG.33.Dx.yy
- Output Filters Design Guide MG.90.Nx.yy
- VLT® AQUA Drive FC 200 Cascade Controller MI.38.Cx.yy
- Application Note MN20A102: Submersible Pump Application
- Application Note MN20B102: Master/Follower Operation Application
- Application Note MN20F102: Drive Closed-loop and Sleep Mode
- Instruction MI.38.Bx.yy: Installation Instruction for Mounting Brackets Enclosure type A5, B1, B2, C1 and C2 IP21, IP55 or IP66
- Instruction MI.90.Lx.yy: Analog I/O Option MCB109
- Instruction MI.33.Hx.yy: Panel through mount kit

x = Revision number

yy = Language code

Danfoss technical literature is also available online at

[www.danfoss.com/BusinessAreas/DrivesSolutions/Documentations/Technical+Documentation.htm](http://www.danfoss.com/BusinessAreas/DrivesSolutions/Documentations/Technical+Documentation.htm).

### 1.1.3 Approvals



1

### 1.1.4 Symbols

Symbols used in this Instruction Manual.





**1**

## 2 Safety

### 2.1.1 Safety Note



The voltage of the adjustable frequency drive is dangerous whenever connected to line power. Incorrect installation of the motor, adjustable frequency drive or serial communication bus may cause damage to the equipment, serious personal injury or death. Consequently, the instructions in this manual, as well as national and local rules and safety regulations, must be complied with.

#### Safety Regulations

1. The adjustable frequency drive must be disconnected from line power if repair work is to be carried out. Make sure that the line power supply has been disconnected and that the necessary time has passed before removing motor and line power plugs.
2. The [STOP/RESET] key on the control panel of the adjustable frequency drive does not disconnect the equipment from line power and is thus not to be used as a safety switch.
3. Correct protective grounding of the equipment must be established, the user must be protected against supply voltage, and the motor must be protected against overload in accordance with applicable national and local regulations.
4. The ground leakage currents are higher than 3.5 mA.
5. Protection against motor overload is set by par. 1-90 *Motor Thermal Protection*. If this function is desired, set par. 1-90 to data value [ETR trip] (default value) or data value [ETR warning]. Note: The function is initialized at 1.16 x rated motor current and rated motor frequency. For the North American market: The ETR functions provide class 20 motor overload protection in accordance with NEC.
6. Do not remove the plugs for the motor and line power supply while the adjustable frequency drive is connected to line power. Make sure that the line power supply has been disconnected and that the necessary time has passed before removing motor and line power plugs.
7. Please note that the adjustable frequency drive has more voltage inputs than L1, L2 and L3 when load sharing (linking of the DC intermediate circuit) and external 24 V DC have been installed. Make sure that all voltage inputs have been disconnected and that the necessary time has passed before commencing repair work.

#### Installation at High Altitudes



##### Installation at high altitude:

380–480 V: At altitudes above 10,000 ft [3 km], please contact Danfoss Drives regarding PELV.  
525–690 V: At altitudes above 6,600 ft [2 km], please contact Danfoss Drives regarding PELV.

#### Warning against Unintended Start

1. The motor can be brought to a stop by means of digital commands, bus commands, references or a local stop, while the adjustable frequency drive is connected to line power. If personal safety considerations make it necessary to ensure that no unintended start occurs, these stop functions are not sufficient. 2. While parameters are being changed, the motor may start. Consequently, the stop key [RESET] must always be activated; following which data can be modified. 3. A motor that has been stopped may start if faults occur in the electronics of the adjustable frequency drive, or if a temporary overload or a fault in the supply line power or the motor connection ceases.



##### Warning:

Touching the electrical parts may be fatal - even after the equipment has been disconnected from line power.

Also make sure that other voltage inputs have been disconnected, such as external 24 V DC, load sharing (linkage of DC intermediate circuit), as well as the motor connection for kinetic backup.

### 2.1.2 General Warning



#### Leakage Current

The ground leakage current from the VLT AQUA Drive FC 200 exceeds 3.5 mA. According to IEC 61800-5-1, a reinforced protective ground connection must be ensured by means of: a min. 0.016 in<sup>2</sup> [10 mm<sup>2</sup>] Cu or 0.025 in<sup>2</sup> [16 mm<sup>2</sup>] Al PE-wire, or an additional PE wire - with the same cable cross-section as the line power wiring - must be terminated separately.

#### Residual Current Device

This product can cause DC current in the protective conductor. Where a residual current device (RCD) is used for extra protection, only an RCD of Type B (time delayed) shall be used on the supply side of this product. See also RCD Application Note MN.90.GX.02.

Protective grounding of the VLT AQUA Drive FC 200 and the use of RCDs must always follow national and local regulations.

### 2.1.3 Before Commencing Repair Work

1. Disconnect the adjustable frequency drive from line power.
2. Disconnect DC bus terminals 88 and 89
3. Wait at least the time mentioned above in the section General Warning.
4. Remove motor cable

### 2.1.4 Special Conditions

#### Electrical Ratings:

The rating indicated on the nameplate of the adjustable frequency drive is based on a typical 3-phase line power supply within the specified voltage, current and temperature ranges, which are expected to be used in most applications.

**The adjustable frequency drives also support other special applications, which affect the electrical ratings of the adjustable frequency drive. Special conditions that affect the electrical ratings might be:**

- Single phase applications.
- High temperature applications which require derating of the electrical ratings
- Marine applications with more severe environmental conditions.

Consult the relevant clauses in these instructions and in the **VLT® AQUA Drive Design Guide** for information about the electrical ratings.

#### Installation requirements:

**The overall electrical safety of the adjustable frequency drive requires special installation considerations regarding:**

- Fuses and circuit breakers for overcurrent and short-circuit protection
- Selection of power cables (line power, motor, brake, load sharing and relay)
- Grid configuration (IT,TN, grounded leg, etc.)
- Safety of low-voltage ports (PELV conditions).

Consult the relevant clauses in these instructions and in the **VLT® AQUA Drive Design Guide** for information about the installation requirements.

### 2.1.5 Caution



The adjustable frequency drive DC link capacitors remain charged after power has been disconnected. To avoid an electrical shock hazard, disconnect the adjustable frequency drive from line power before carrying out maintenance. Wait at least as follows before doing service on the adjustable frequency drive:

Voltage (V)	Min. Waiting Time (Minutes)				
	4	15	20	30	40
200 - 240	0.34–5 hp [0.25–3.7 kW]    7.5–60 hp [5.5–45 kW]				
380 - 480	0.5–10 hp [0.37–7.5 kW]		15–125 hp [11–90 kW]    150–350 hp [110–250 kW]		450–1350 hp [315–1000 kW]
525-600	1–10 hp [0.75 kW–7.5 kW]		15–125 hp [11–90 kW]		
525-690			15–125 hp [11–90 kW]	60–550 hp [45–400 kW]	600–1600 hp [450–1200 kW]

Be aware that there may be high voltage on the DC link even when the LEDs are turned off.

### 2.1.6 Avoid Unintended Start

**NOTE!**

While the adjustable frequency drive is connected to line power, the motor can be started/stopped using digital commands, bus commands, references or via the Local Control Panel.

- Disconnect the adjustable frequency drive from line power whenever personal safety considerations make it necessary to avoid an unintended start.
- To avoid unintended start, always activate the [OFF] key before changing parameters.
- Unless terminal 37 is turned off, an electronic fault, temporary overload, a fault in the line power supply, or lost motor connection may cause a stopped motor to start.

### 2.1.7 IT Line Power



**IT line power**

Do not connect adjustable frequency drives with RFI filters to line power supplies with a voltage between phase and ground of more than 440 V for 400 V drives and 760 V for 690 V drives.

For 400 VT IT line power and delta ground (grounded leg), AC line voltage may exceed 440 V between phase and ground.

For 690 VT IT line power and delta ground (grounded leg), AC line voltage may exceed 760 V between phase and ground.

par. 14-50 *RFI 1* can be used to disconnect the internal RFI capacitors from the RFI filter to ground.

### 2.1.8 Disposal Instructions



Equipment containing electrical components may not be disposed of together with domestic waste. It must be separately collected with electrical and electronic waste according to local and currently valid legislation.

### 2.1.9 Safe Stop of the Adjustable Frequency Drive (optional)

For versions fitted with a safe stop terminal 37 input, the adjustable frequency drive can perform the safety function *Safe Torque Off* (As defined by draft CD IEC 61800-5-2) or *Stop Category 0* (as defined in EN 60204-1).

2

It is designed and deemed suitable for the requirements of Safety Category 3 in EN 954-1. This function is called safe stop. Prior to integrating and using safe stop in an installation, a thorough risk analysis must be carried out on the installation in order to determine whether the safe stop functionality and safety category are appropriate and sufficient. In order to install and use the Safe Stop function in accordance with the requirements of Safety Category 3 in EN 954-1, the related information and instructions of the VLT AQUA Drive Design Guide MG.20.NX.YY must be followed! The information and instructions contained in the Instruction Manual are not sufficient for a correct and safe use of the safe stop functionality!

Prüf- und Zertifizierungsstelle im BG-PRÜFZERT		 <b>BGIA</b> Berufsgenossenschaftliches Institut für Arbeitsschutz Hauptverband der gewerblichen Berufsgenossenschaften	
Translation <small>In any case, the German original shall prevail.</small>		<b>Type Test Certificate</b>	
		05 06004 <small>No. of certificate</small>	
Name and address of the holder of the certificate (customer):	Danfoss Drives A/S, Ulmøse 1 DK-6300 Grøsten, Denmark		
Name and address of the manufacturer:	Danfoss Drives A/S, Ulmøse 1 DK-6300 Grøsten, Denmark		
Ref. of customer:	Ref. of Test and Certification Body: ApfKGh 16 No. 2003 23220	Date of issue: 13.04.2005	
Product designation:	Frequency converter with integrated safety functions		
Type:	VLT® Automation Drive FC 302		
Intended purpose:	Implementation of safety function „Safe Stop“		
Testing based on:	EN 954-1, 1997-03, DKE AK 226.03, 1998-06, EN ISO 13849-2, 2003-12, EN 61800-3, 2001-02, EN 61800-5-1, 2003-09,		
Test certificate:	No.: 2003 23220 from 13.04.2005		
Remarks:	The presented types of the frequency converter FC 302 meet the requirements laid down in the test bases. With correct wiring a category 3 according to DIN EN 954-1 is reached for the safety function.		
The type tested complies with the provisions laid down in the directive 98/37/EC (Machinery).			
Further conditions are laid down in the Rules of Procedure for Testing and Certification of April 2004.			
Head of certification body  <small>(Prof. Dr. rer. nat. Detmar Reinert)</small>		Certification officer  <small>(Dipl.-Ing. R. ApfM)</small>	
FEB/08 05.05	 Postal address: 53754 Seelz-Asquith	Office: Allee Heerstraße 111 53757 Seelz-Asquith	Phone: 0 22 45/0 31-00 Fax: 0 22 45/0 31-29 34

130BA373.11

## 3 Introduction

### 3.1.1 Type Code String - Medium Power

1	2	3	4	5	6	7	8	9	10	11	12	13	14	15	16	17	18	19	20	21	22	23	24	25	26	27	28	29	30	31	32	33	34	35	36	37	38	39
FC	-	2	0	2	P					T						H						X	X	S	X	X	X	X	A		B		C					D

130BA484.10

3

Description	Pos.:	Possible choice
Product group & VLT Series	1-6	FC 202
Power rating	7-10	0.34–1600 hp [0.25–1200 kW]
Number of phases	11	Three phases (T)
AC line voltage	11-12	S2: 220–240 V AC single phase S4: 380–480 V AC single phase T 2: 200–240 V AC T 4: 380–480 V AC T 6: 525–600 V AC T 7: 525–690 V AC
Enclosure	13-15	E20: IP20 E21: IP 21/NEMA Type 1 E55: IP 55/NEMA Type 12 E2M: IP21/NEMA Type 1 w/ line power shield E5M: IP 55/NEMA Type 12 w/ line power shield E66: IP66 F21: IP21 kit without backplate G21: IP21 kit with backplate P20: IP20/chassis with backplate P21: IP21/NEMA Type 1 w/ backplate P55: IP55/NEMA Type 12 w/ backplate
RFI filter	16-17	HX: No RFI filter H1: RFI filter class A1/B H2: RFI filter class A2 H3: RFI filter class A1/B (reduced cable length) H4: RFI filter class A2/A1
Brake	18	X: No brake chopper included B: Brake chopper included T: Safe Stop U: Safe + brake
Display	19	G: Graphical Local Control Panel (GLCP) N: Numeric Local Control Panel (NLCP) X: No Local Control Panel
Coating PCB	20	X: No coated PCB C: Coated PCB
Line power option	21	D: Loadsharing X: No line power disconnect switch 8: Line Power Disconnect + Loadsharing
Cable entries	22	X: Standard cable entries O: European metric thread in cable entries
	23	Reserved
Software release	24-27	Current software version
Software language	28	

Table 3.1: Type code description.

Description	Pos.:	Possible choice
A options	29-30	AX: No options A0: MCA 101 Profibus DP V1 A4: MCA 104 DeviceNet AN: MCA 121 Ethernet IP
B options	31-32	BX: No option BK: MCB 101 General purpose I/O option BP: MCB 105 Relay option BO: MCB 109 Analog I/O option BY: MCO 101 Extended Cascade Control
C <sub>0</sub> options	33-34	CX: No options
C1 options	35	X: No options 5: MCO 102 Advanced Cascade Control
C option software	36-37	XX: Standard software
D options	38-39	DX: No option D0: DC backup
The various options are described further in this Design Guide.		

Table 3.2: Type code description.





**3**

## 4 Mechanical Installation

### 4.1 Before Starting

#### 4.1.1 Checklist

When unpacking the adjustable frequency drive, make sure that the unit is undamaged and complete. Use the following table to identify the packaging:












Enclosure type:	A2 (IP 20/ 21)	A3 (IP 20/21)	A5 (IP 55/ 66)	B1/B3 (IP20/ 21/ 55/ 66)	B2/B4 (IP20/ 21/ 55/66)	C1/C3 (IP20/21/ 55/66)	C2/C4 (IP20/21/ 55/66)
<b>Unit size (kW):</b>							
200–240 V	0.25–3.0	3.7	0.25–3.7	5.5–11/ 5.5–11	15/ 15–18.5	18.5–30/ 22–30	37-45/ 37-45
380–480 V	0.37–4.0	5.5–7.5	0.37–7.5	11–18.5/ 11–18.5	22-30/ 22-37	37-55/ 45-55	75 - 90/ 75-90
525–600 V		0.75–7.5	0.75–7.5	11–18.5/ 11–18.5	22-37/ 22-37	45-55/ 45-55	75 - 90/ 75-90
525–690 V	-	-	-	-/ -	11-30/ -	-/ -	37-90/ -

Table 4.1: Unpacking table

Please note that a selection of screwdrivers (Phillips or cross-thread screwdriver and Torx), a side-cutter, drill and knife is also recommended to have handy for unpacking and mounting the adjustable frequency drive. The packaging for these enclosures contains, as shown: accessory bag(s), documentation and the unit. Depending on options fitted, there may be one or two bags and one or more booklets.

**4**

**4.2.1 Mechanical Front Views**

										
IP20/21*	IP20/21*	IP55/66	IP21/55/66	IP21/55/66	IP20/21*	IP20/21*	IP21/55/66	IP21/55/66	IP20/21*	IP20/21*

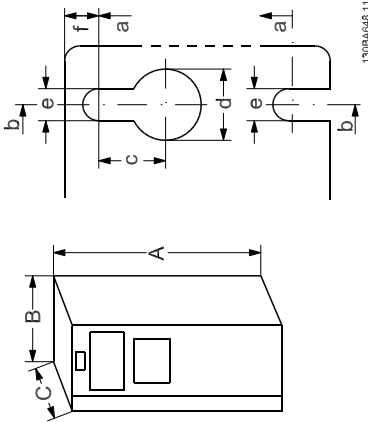


Figure 4.1: Top and bottom mounting holes.

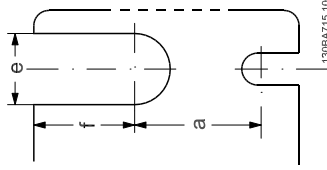


Figure 4.2: Top and bottom mounting holes. (B4+C3+C4 only)

Accessory bags containing necessary brackets, screws and connectors are included with the drives upon delivery.

\* IP21 can be established with a kit as described in the section: IP 21/ IP 4X/ TYPE 1 Enclosure Kit in the Design Guide.

All measurements in mm.

**4.2.2 Mechanical Dimensions**

		Mechanical dimensions											
Frame size (kW):		A2	A3	A5	B1	B2	B3	B4	C1	C2	C3	C4	
200-240 V	T2	0.25-3.0	3.7	0.25-3.7	5.5-11	15	5.5-11	15-18.5	18.5-30	37-45	22-30	37-45	
380-480 V	T4	0.37-4.0	5.5-7.5	0.37-7.5	11-18.5	22-30	11-18.5	22-37	37-55	75-90	45-55	75-90	
525-600 V	T6	-	0.75-7.5	0.75-7.5	11-18.5	22-30	11-18.5	22-37	37-55	75-90	45-55	75-90	
525-690 V	T7	-	-	-	-	11-30	-	-	-	37-90	-	-	
IP		20	21	55/66	21/ 55/66	21/55/66	20	20	21/55/66	21/55/66	20	20	
NEMA		Chassis	Type 1	Type 12	Type 1/12	Type 1/12	Chassis	Chassis	Type 1/12	Type 1/12	Chassis	Chassis	
<b>Height (mm)</b>													
Enclosure	A**	246	372	420	480	650	350	460	680	770	490	600	
.with de-coupling plate	A2	374	-	-	-	-	419	595	-	-	630	800	
Backplate	A1	268	375	420	480	650	399	520	680	770	550	660	
Distance between mount. holes	a	257	350	402	454	624	380	495	648	739	521	631	
<b>Width (mm)</b>													
Enclosure	B	90	130	242	242	242	165	231	308	370	308	370	
With one C option	B	130	170	242	242	242	205	231	308	370	308	370	
Backplate	B	90	130	242	242	242	165	231	308	370	308	370	
Distance between mount. holes	b	70	110	215	210	210	140	200	272	334	270	330	
<b>Depth (mm)</b>													
Without option A/B	C	205	205	200	260	260	248	242	310	335	333	333	
With option A/B	C*	220	220	200	260	260	262	242	310	335	333	333	
<b>Screw holes (mm)</b>													
Diameter ø	c	8.0	8.0	8.2	12	12	8	-	12	12	-	-	
Diameter ø	d	11	11	12	19	19	12	-	19	19	-	-	
Diameter ø	e	5.5	5.5	6.5	9	9	6.8	8.5	9.0	9.0	8.5	8.5	
Diameter ø	f	9	9	9	9	9	7.9	15	9.8	9.8	17	17	
<b>Max weight (kg)</b>													
		4.9	5.3	14	23	27	12	23.5	45	65	35	50	

\* Depth of enclosure will vary with different options installed.

\*\* The free space requirements are above and below the bare enclosure height measurement A. See section 3.2.3 for further information.

### 4.2.3 Mechanical Mounting

All IP20 enclosure sizes as well as IP21/ IP55 enclosure sizes except A2 and A3 allow side-by-side installation.

If the IP 21 Enclosure kit (130B1122 or 130B1123) is used on enclosure A2 or A3,, there must be a minimum of 2 in [50 mm] of clearance between drives.

For optimal cooling conditions, allow a free air passage above and below the adjustable frequency drive. See table below.

**Air passage for different enclosures**

Enclosure:	A2	A3	A5	B1	B2	B3	B4	C1	C2	C3	C4
a (mm):	100	100	100	200	200	200	200	200	225	200	225
b (mm):	100	100	100	200	200	200	200	200	225	200	225

1. Drill holes in accordance with the measurements given.
2. You must provide screws suitable for the surface on which you want to mount the adjustable frequency drive. Re-tighten all four screws.

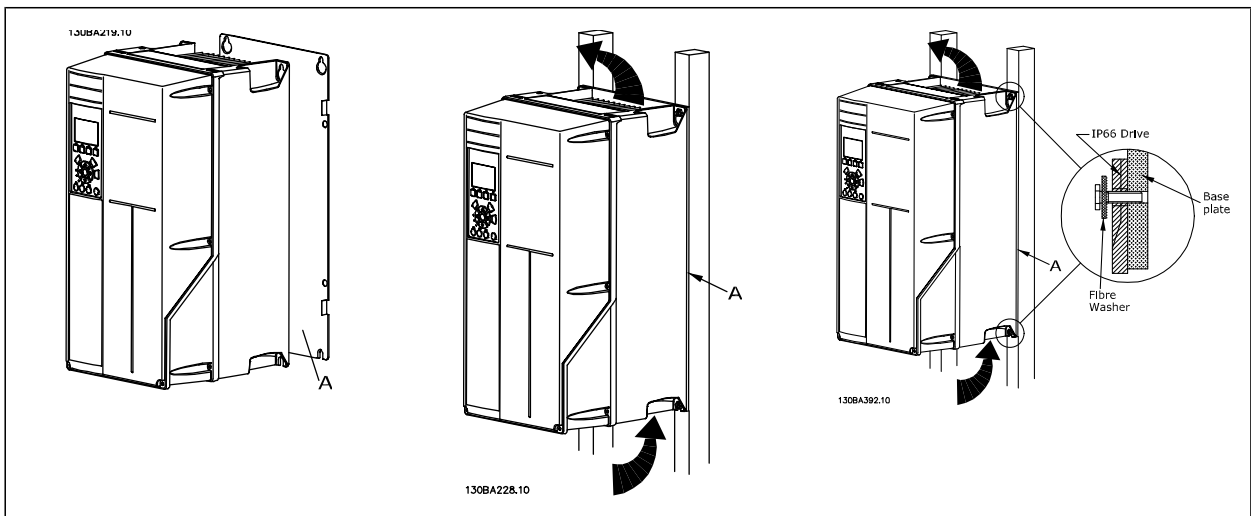


Table 4.2: Mounting frame sizes A5, B1, B2, B3, B4, C1, C2, C3 and C4 on a non-solid back wall, the drive must be provided with a backplate A due to insufficient cooling air over the heatsink.

For heavier drives (B4, C3, C4), use a lift. First wall-mount the 2 lower bolts, then lift the drive onto the lower bolts. Finally, fasten the drive against the wall with the 2 top bolts.

#### 4.2.4 Safety Requirements for Mechanical Installation



Pay attention to the requirements that apply to integration and the field mounting kit. Follow the information in the list to avoid serious damage or injury, especially when installing large units.

The adjustable frequency drive is cooled by air circulation.

To protect the unit from overheating, it must be ensured that the ambient temperature *does not exceed the maximum temperature stated for the adjustable frequency drive*, and that the 24-hour average temperature *is not exceeded*. Locate the maximum temperature and 24-hour average in the paragraph *Derating for Ambient Temperature*.

If the ambient temperature is in the range of 113°–131°F [45°–55°C], derating of the adjustable frequency drive will become relevant, see *Derating for Ambient Temperature*.

The service life of the adjustable frequency drive is reduced if derating for ambient temperature is not taken into account.

4

#### 4.2.5 Field Mounting

For field mounting the IP 21/IP 4X top/,TYPE 1 kits or IP 54/55 units are recommended.

#### 4.2.6 Panel Through Mounting

A Panel Through Mount Kit is available for adjustable frequency drive series , VLT Aqua Drive and.

In order to increase heatsink cooling and reduce panel depth, the adjustable frequency drive may be mounted in a through panel. Furthermore, the built-in fan can then be removed.

The kit is available for enclosures A5 through C2.



**NOTE!**

This kit cannot be used with cast front covers. No cover or IP21 plastic cover must be used instead.

Information on ordering numbers is found in the *Design Guide*, section *Ordering Numbers*.

More detailed information is available in the *Panel Through Mount Kit instruction*, *MI.33.H1.YY*, where yy=language code.

## 5 Electrical Installation

### 5.1 How to Connect

#### 5.1.1 Cables General



**NOTE!**

Always comply with national and local regulations on cable cross-sections.

**Details of terminal tightening torques.**

Enclosure	Power (kW)			Torque (Nm)					
	200–240 V	380–480 V	525–600 V	Line power	Motor	DC connection	Brake	Ground	Relay
A2	0.25–3.0	0.37–4.0		1.8	1.8	1.8	1.8	3	0.6
A3	3.7	5.5–7.5	0.75–7.5	1.8	1.8	1.8	1.8	3	0.6
A5	0.25–3.7	0.37–7.5	0.75–7.5	1.8	1.8	1.8	1.8	3	0.6
B1	5.5–11	11–18.5	-	1.8	1.8	1.5	1.5	3	0.6
B2	-	22	-	4.5	4.5	3.7	3.7	3	0.6
	15	30	-	4.5 <sup>2)</sup>	4.5 <sup>2)</sup>	3.7	3.7	3	0.6
B3	5.5–11	11–18.5	11–18.5	1.8	1.8	1.8	1.8	3	0.6
B4	15–18.5	22 - 37	22 - 37	4.5	4.5	4.5	4.5	3	0.6
C1	18.5–30	37 - 55	-	10	10	10	10	3	0.6
C2	37	75	-	14	14	14	14	3	0.6
	45	90	-	24	24	14	14	3	0.6
C3	22 - 30	45 - 55	45 - 55	10	10	10	10	3	0.6
C4	37 - 45	75 - 90	75 - 90	14	14	14	14	3	0.6

Table 5.1: Tightening of terminals

1. For different cable dimensions x/y where  $x \leq 0.147 \text{ in}^2 [95 \text{ mm}^2]$  and  $y \geq 0.147 \text{ in}^2 [95 \text{ mm}^2]$ .
2. Cable dimensions above 25 hp [18.5 kW]  $\geq 0.0542 \text{ in}^2 [35 \text{ mm}^2]$  and below 30 hp [22 kW]  $\leq 0.0155 \text{ in}^2 [10 \text{ mm}^2]$

#### 5.1.2 Grounding and IT Line Power



The ground connection cable cross-section must be at least  $0.016 \text{ in}^2 [10 \text{ mm}^2]$  or 2 rated line power wires terminated separately according to *EN 50178* or *IEC 61800-5-1* unless national regulations specify differently. Always comply with national and local regulations on cable cross-sections.

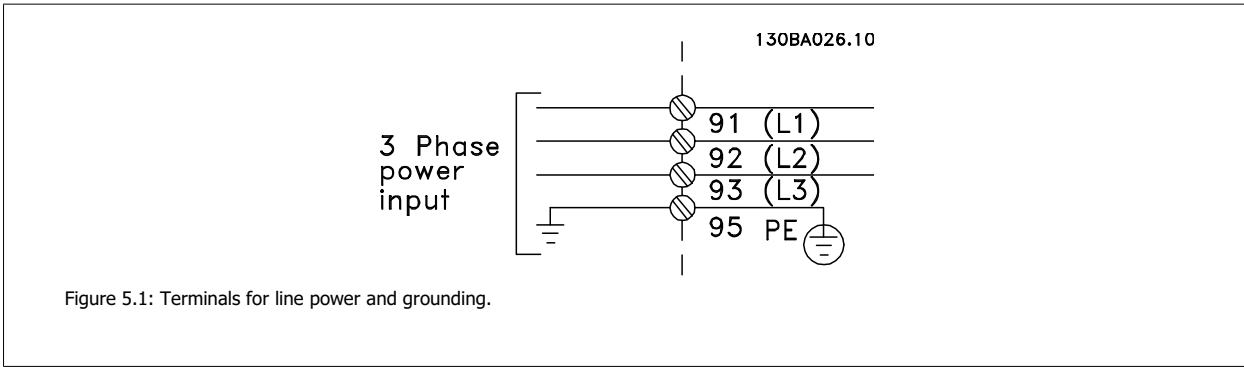
The line power is connected to the main disconnect switch if this is included.



**NOTE!**

Make sure that the AC line voltage corresponds to the AC line voltage of the adjustable frequency drive nameplate.





5



**IT Line Power**

Do not connect 400 V adjustable frequency drives with RFI filters to line power supplies with a voltage between phase and ground of more than 440 V.

For IT line power and delta ground (grounded leg), AC line voltage may exceed 440 V between phase and ground.

### 5.1.3 Line Power Wiring Overview








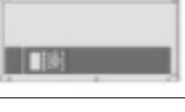



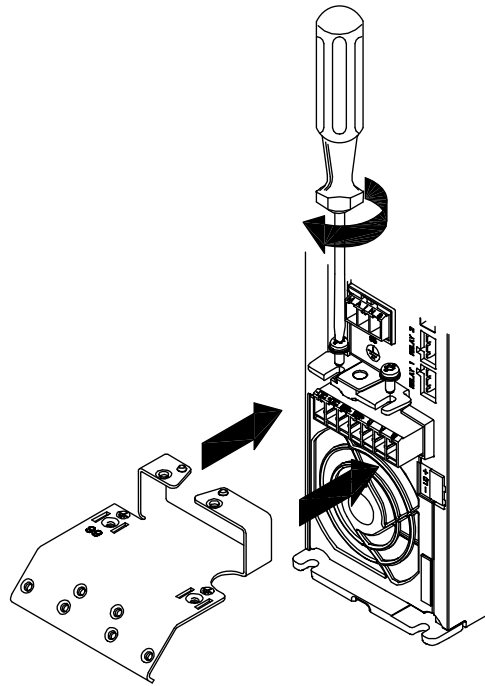
Enclosure:	A2 (IP 20/IP 21)	A3 (IP 20/IP 21)	A5 (IP 55/IP 66)	B1 (IP 21/IP 55/IP 66)	B2 (IP 21/IP 55/IP 66)	B3 (IP 20)	B4 (IP 20)	C1 (IP 21/IP 55/66)	C2 (IP 21/IP 55/66)	C3 (IP 20)	C4 (IP 20)
											
<b>Motor size (kW):</b>	0.25-3.0	3.7	1.1-3.7	5.5-11	15	5.5-11	15-18.5	18.5-30	37-45	22-30	37-45
200-240 V	0.37-4.0	5.5-7.5	1.1-7.5	11-18.5	22-30	11-18.5	22-37	37-55	75-90	45-55	75-90
380-480 V	'	1.1-7.5	1.1-7.5	11-18.5	22-30	11-18.5	22-37	37-55	75-90	45-55	75-90
525-600 V		1.1-7.5	1.1-7.5	11-18.5	22-30	11-18.5	22-37	37-55	75-90	45-55	75-90
525-690 V				11-30	11-30				37-90		
<b>Goto:</b>	<b>5.1.6</b>	<b>5.1.6</b>	<b>5.1.7</b>	<b>5.1.8</b>	<b>5.1.8</b>			<b>5.1.9</b>			<b>5.1.10</b>

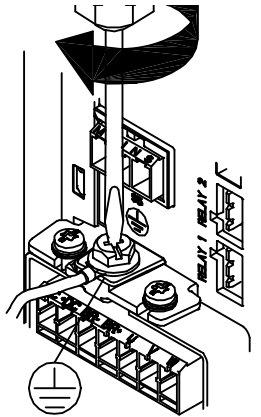
Table 5.2: Line Power Wiring Table.

## 5.1.4 AC Line Input Connections for A2 and A3



130BA261.10

Figure 5.2: First mount the two screws on the mounting plate, slide it into place and tighten fully.



130BA262.10

Figure 5.3: When mounting cables, first mount and tighten ground cable.



The ground connection cable cross-section must be at least 0.016 in<sup>2</sup> [10 mm<sup>2</sup>] or 2 rated line power wires terminated separately according to *EN 50178/IEC 61800-5-1*.

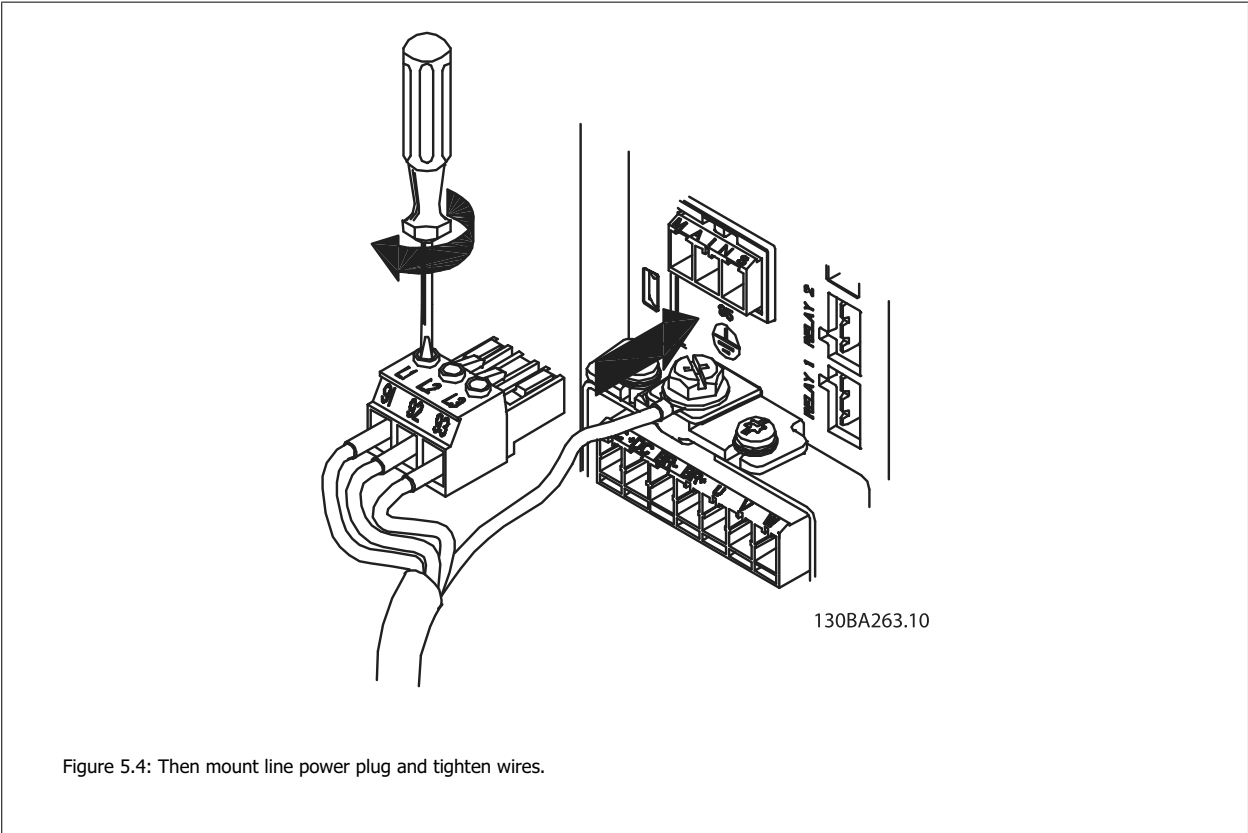


Figure 5.4: Then mount line power plug and tighten wires.

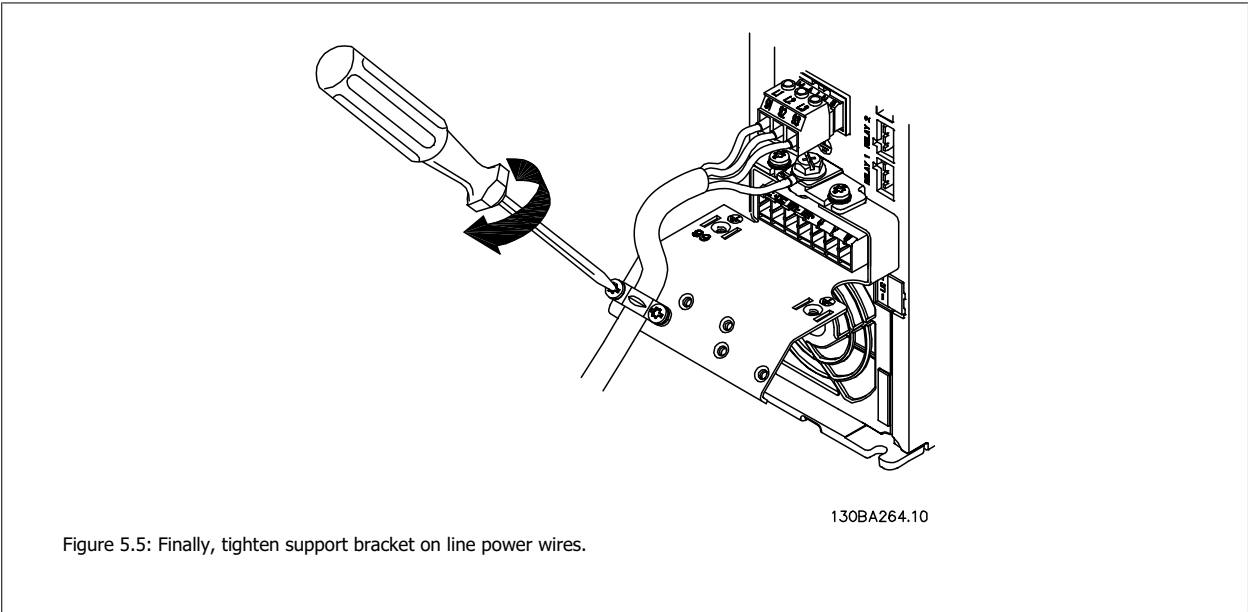


Figure 5.5: Finally, tighten support bracket on line power wires.

**NOTE!**  
With single phase A3 use L1 and L2 terminals.

### 5.1.5 AC Line Input Connections for A5

5

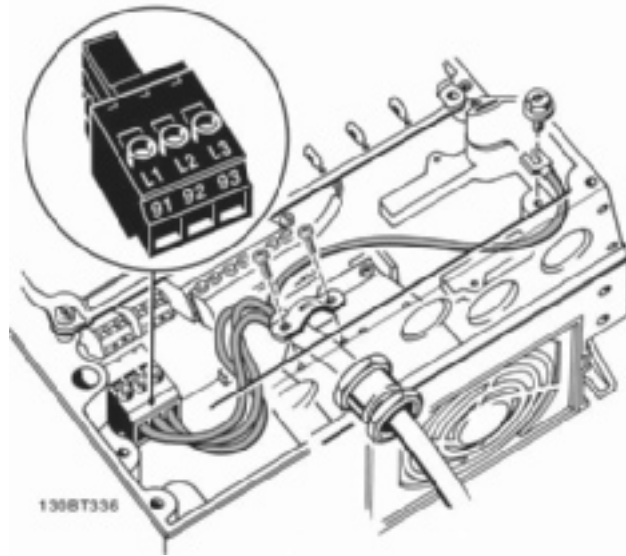


Figure 5.6: How to connect to line power and grounding without a line power disconnect switch. Note that a cable clamp is used.

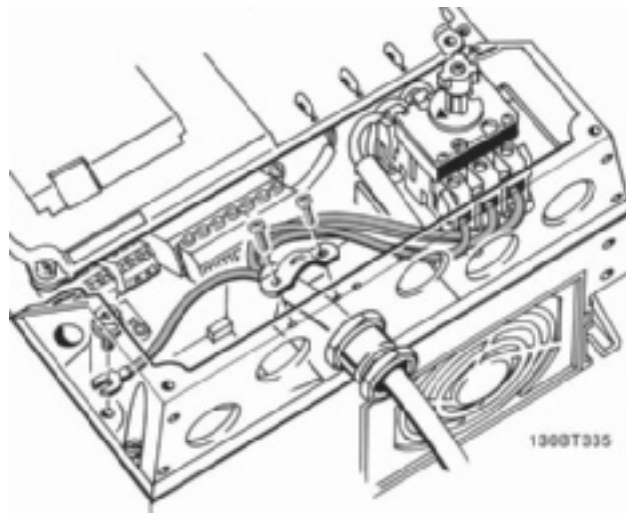


Figure 5.7: How to connect to line power and grounding with a line power disconnect switch.

**NOTE!**

With single phase A5 use L1 and L2 terminals.

### 5.1.6 AC Line Input Connections for B1, B2 and B3

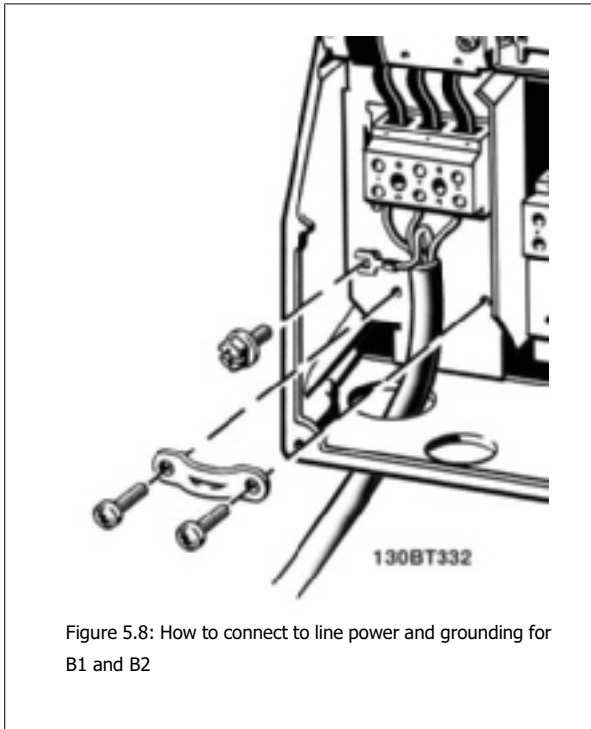


Figure 5.8: How to connect to line power and grounding for B1 and B2

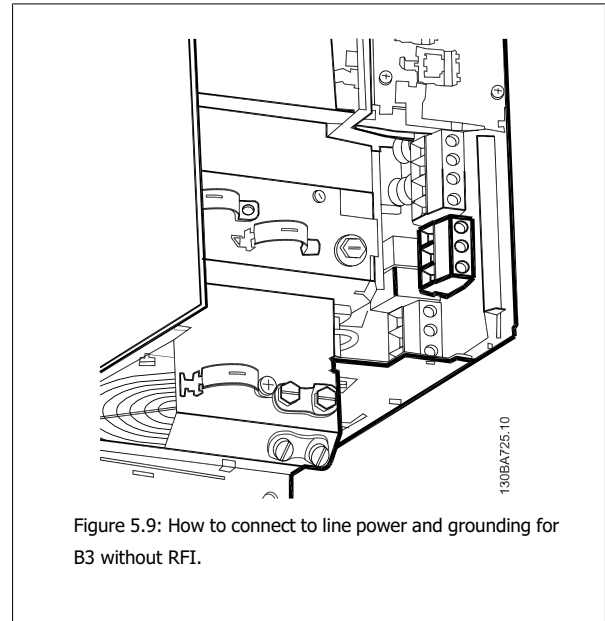


Figure 5.9: How to connect to line power and grounding for B3 without RFI.

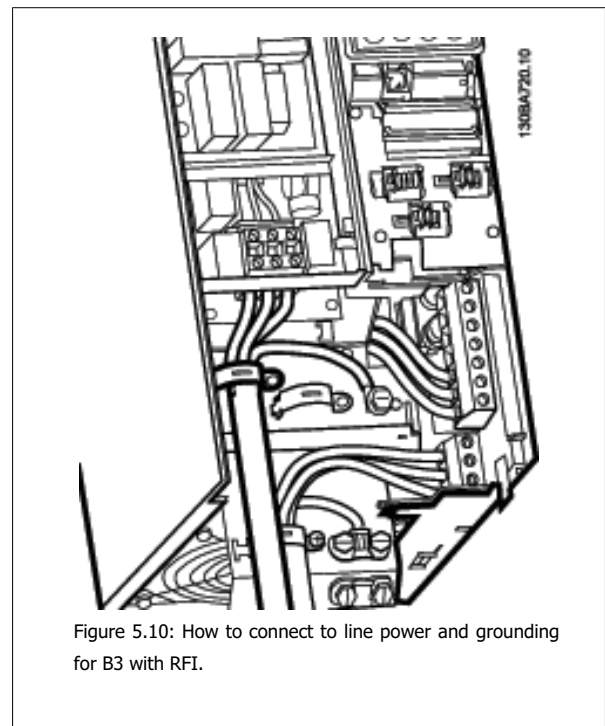


Figure 5.10: How to connect to line power and grounding for B3 with RFI.

**NOTE!**

With single phase B1 use L1 and L2 terminals.



**NOTE!**

For correct cable dimensions, please see the section General Specifications at the back of this manual.

5

**5.1.7 AC Line Input Connections for B4, C1 and C2**

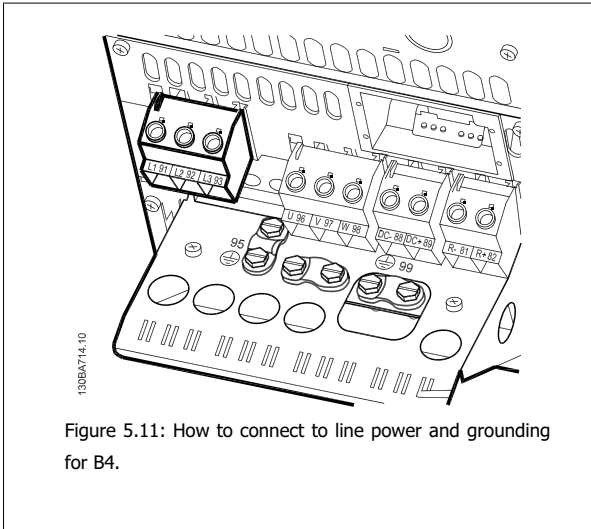


Figure 5.11: How to connect to line power and grounding for B4.

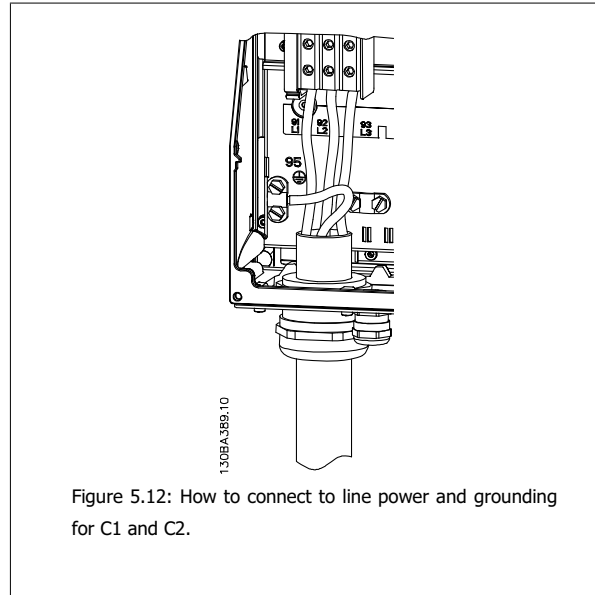


Figure 5.12: How to connect to line power and grounding for C1 and C2.

**5.1.8 AC Line Input Connections for C3 and C4**

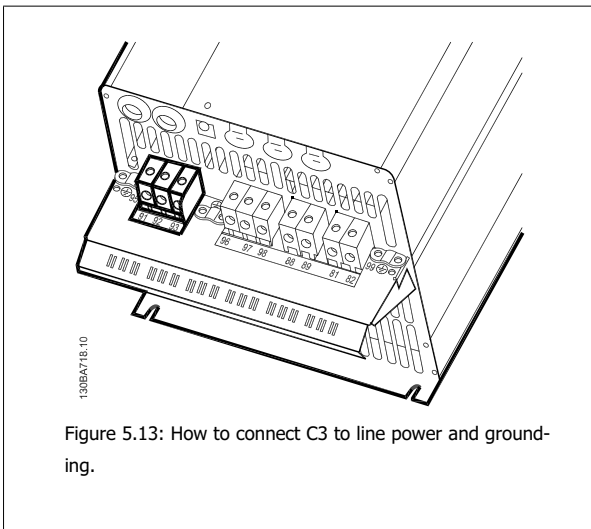


Figure 5.13: How to connect C3 to line power and grounding.

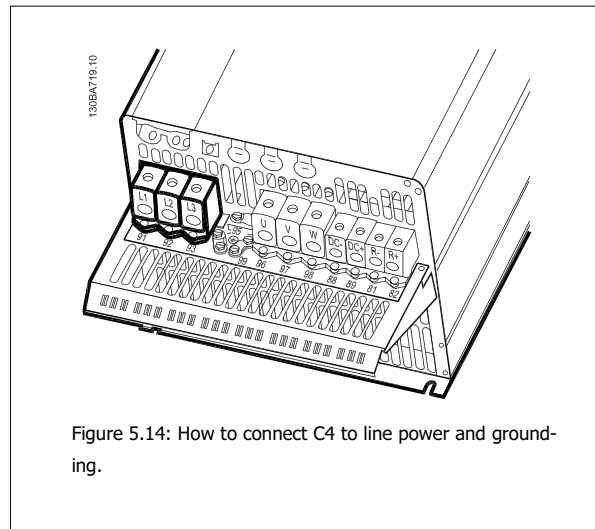


Figure 5.14: How to connect C4 to line power and grounding.

**5.1.9 How to Connect Motor - Introduction**

See section General Specifications for correct dimensioning of motor cable cross-section and length.

- Use a shielded/armored motor cable to comply with EMC emission specifications (or install the cable in a metal conduit).
- Keep the motor cable as short as possible to reduce the noise level and leakage currents.
- Connect the motor cable shield/armor to both the decoupling plate of the adjustable frequency drive and to the metal of the motor. (The same applies to both ends of the metal conduit if used instead of a shield.)

- Make the shield connections with the largest possible surface area (by using a cable clamp or an EMC cable connector). This is done by using the supplied installation devices in the adjustable frequency drive.
- Avoid terminating the shield by twisting the ends (pigtails), as this will spoil high frequency shielding effects.
- If it is necessary to break the continuity of the shield to install a motor isolator or motor relay, the continuity must be maintained with the lowest possible HF impedance.

**Cable length and cross-section**

The adjustable frequency drive has been tested with a given length of cable and a given cross-section of that cable. If the cross-section is increased, the cable capacitance - and thus the leakage current - may increase, thereby requiring that the cable length is reduced accordingly.

**Switching frequency**

When adjustable frequency drives are used together with sine wave filters to reduce the acoustic noise from a motor, the switching frequency must be set according to the sine wave filter instructions in par. 14-01 *Switching Frequency*.

**Precautions while using aluminum conductors**

Aluminum conductors are not recommended for cable cross-sections less than 0.054 in<sup>2</sup> [35 mm<sup>2</sup>]. Terminals can accept aluminum conductors, but the conductor surface has to be clean, oxidation must be removed, and the area must be sealed by neutral acid-free Vaseline grease before the conductor is connected.

Furthermore, the terminal screw must be retightened after two days due to the softness of the aluminum. It is crucial to ensure that the connection makes a gas tight joint, otherwise the aluminum surface will oxidize again.

All types of three-phase asynchronous standard motors can be connected to the adjustable frequency drive. Normally, small motors are star-connected (230/400 V, D/Y). Large motors are delta-connected (400/690 V, D/Y). Refer to the motor nameplate for correct connection mode and voltage.

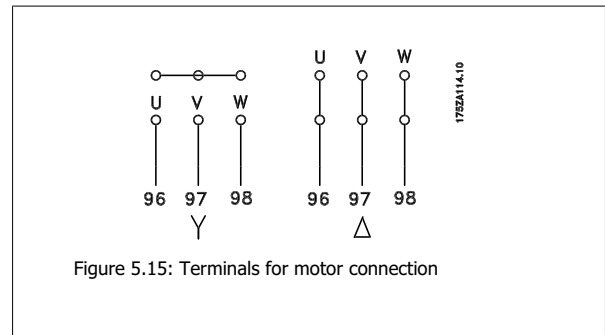


Figure 5.15: Terminals for motor connection



**NOTE!**

In motors without phase insulation paper or other insulation reinforcement suitable for operation with the voltage supply (such as an adjustable frequency drive), fit a sine-wave filter on the output of the adjustable frequency drive. (Motors that comply with IEC 60034-17 do not require a sine-wave filter).

No.	96	97	98	Motor voltage 0–100% of AC line voltage.
	U	V	W	3 cables out of motor
	U1	V1	W1	6 cables out of motor, Delta-connected
	W2	U2	V2	
	U1	V1	W1	6 cables out of motor, Star-connected
				U2, V2, W2 to be interconnected separately (optional terminal block)
No.	99			Ground connection
	PE			

Table 5.3: 3 and 6 cable motor connection.



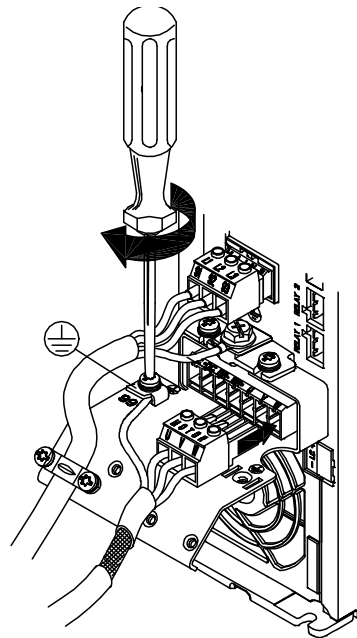
**5.1.10 Motor Wiring Overview**

Enclosure:	A2 (IP 20/IP 21)	A3 (IP 20/IP 21)	A5 (IP 55/IP 66)	B1 (IP 21/IP 55/ IP 66)	B2 (IP 21/IP 55/ IP 66)	B3 (IP 20)	B4 (IP 20)	C1 (IP 21/IP 55/66)	C2 (IP 21/IP 55/66)	C3 (IP 20)	C4 (IP 20)
<b>Motor size (kW):</b>											
200-240 V	0.25-3.0	3.7	1.1-3.7	5.5-11	15	5.5-11	15-18.5	18.5-30	37-45	22-30	37-45
380-480 V	0.37-4.0	5.5-7.5	1.1-7.5	11-18.5	22-30	11-18.5	22-37	37-55	75-90	45-55	75-90
525-600 V		1.1-7.5	1.1-7.5	11-18.5	22-30	11-18.5	22-37	37-55	75-90	45-55	75-90
525-690 V					11-30				37-90		
<b>Goto:</b>		<b>5.1.13</b>	<b>5.1.14</b>	<b>5.1.15</b>			<b>5.1.16</b>		<b>5.1.17</b>		<b>5.1.18</b>

Table 5.4: Motor Wiring Table.

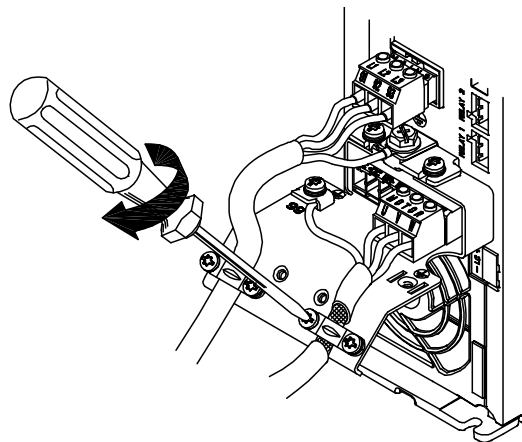
### 5.1.11 Motor Connection for A2 and A3

Follow these drawings step-by-step for connecting the motor to the adjustable frequency drive.



130BA265.10

Figure 5.16: First terminate the motor ground, then place motor U, V and W wires in the plug and tighten them.



130BA266.10

Figure 5.17: Mount cable clamp to ensure 360 degree connection between chassis and shield; ensure that the outer insulation of the motor cable is removed under the clamp.

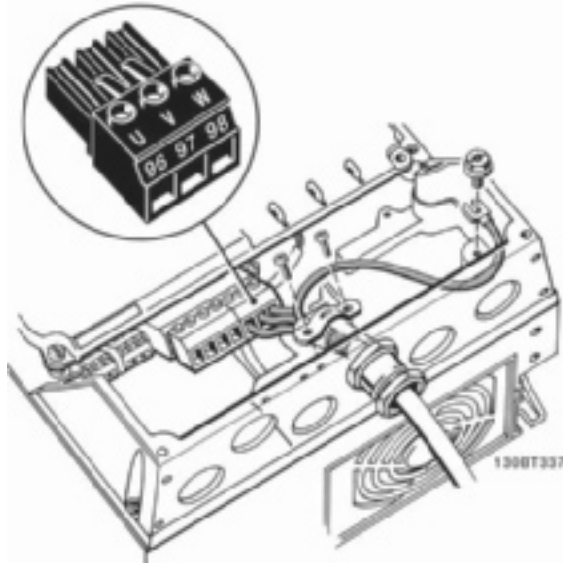
**5.1.12 Motor Connection for A5**

Figure 5.18: First, terminate the motor ground, then insert the motor U, V and W wires in the terminal and tighten them. Please ensure that the outer insulation of the motor cable is removed under the EMC clamp.

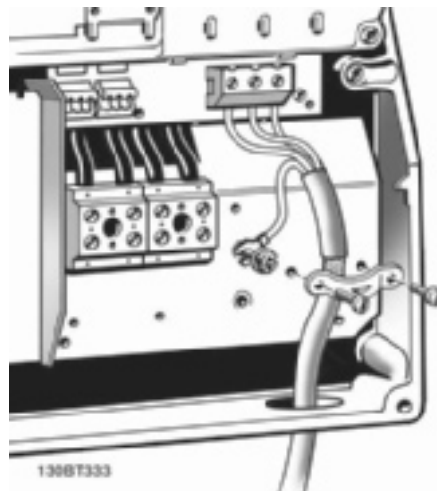
**5.1.13 Motor Connection for B1 and B2**

Figure 5.19: First terminate the motor ground, then place motor U, V and W wires in the terminal and tighten them. Please ensure that the outer insulation of the motor cable is removed under the EMC clamp.

### 5.1.14 Motor Connection for B3 and B4

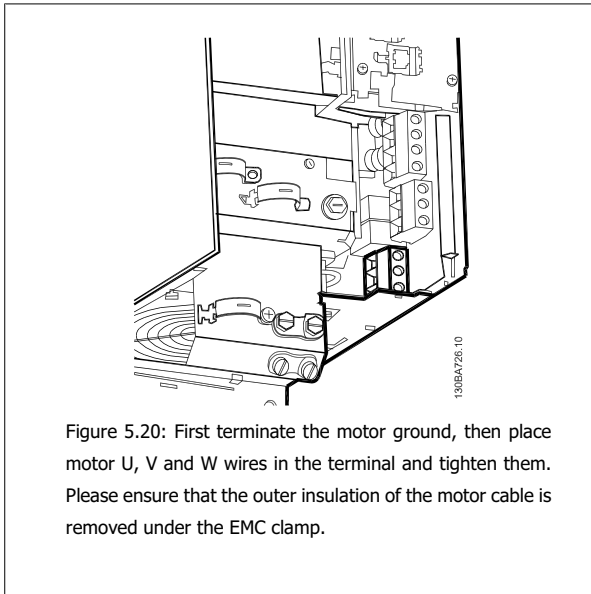


Figure 5.20: First terminate the motor ground, then place motor U, V and W wires in the terminal and tighten them. Please ensure that the outer insulation of the motor cable is removed under the EMC clamp.

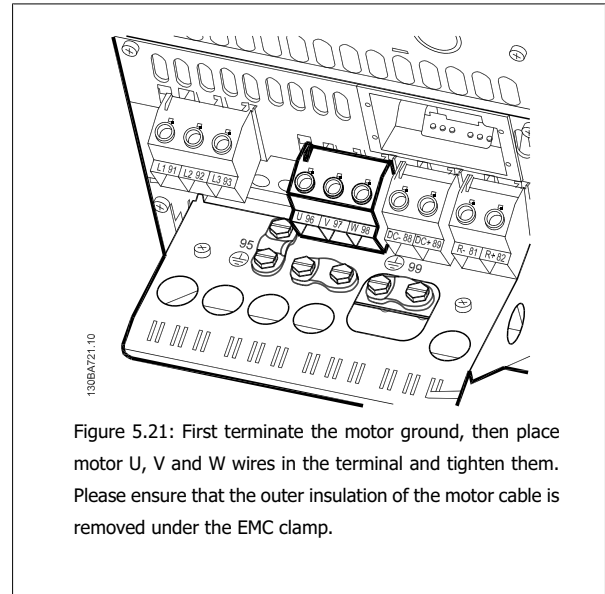


Figure 5.21: First terminate the motor ground, then place motor U, V and W wires in the terminal and tighten them. Please ensure that the outer insulation of the motor cable is removed under the EMC clamp.

5

### 5.1.15 Motor Connection for C1 and C2

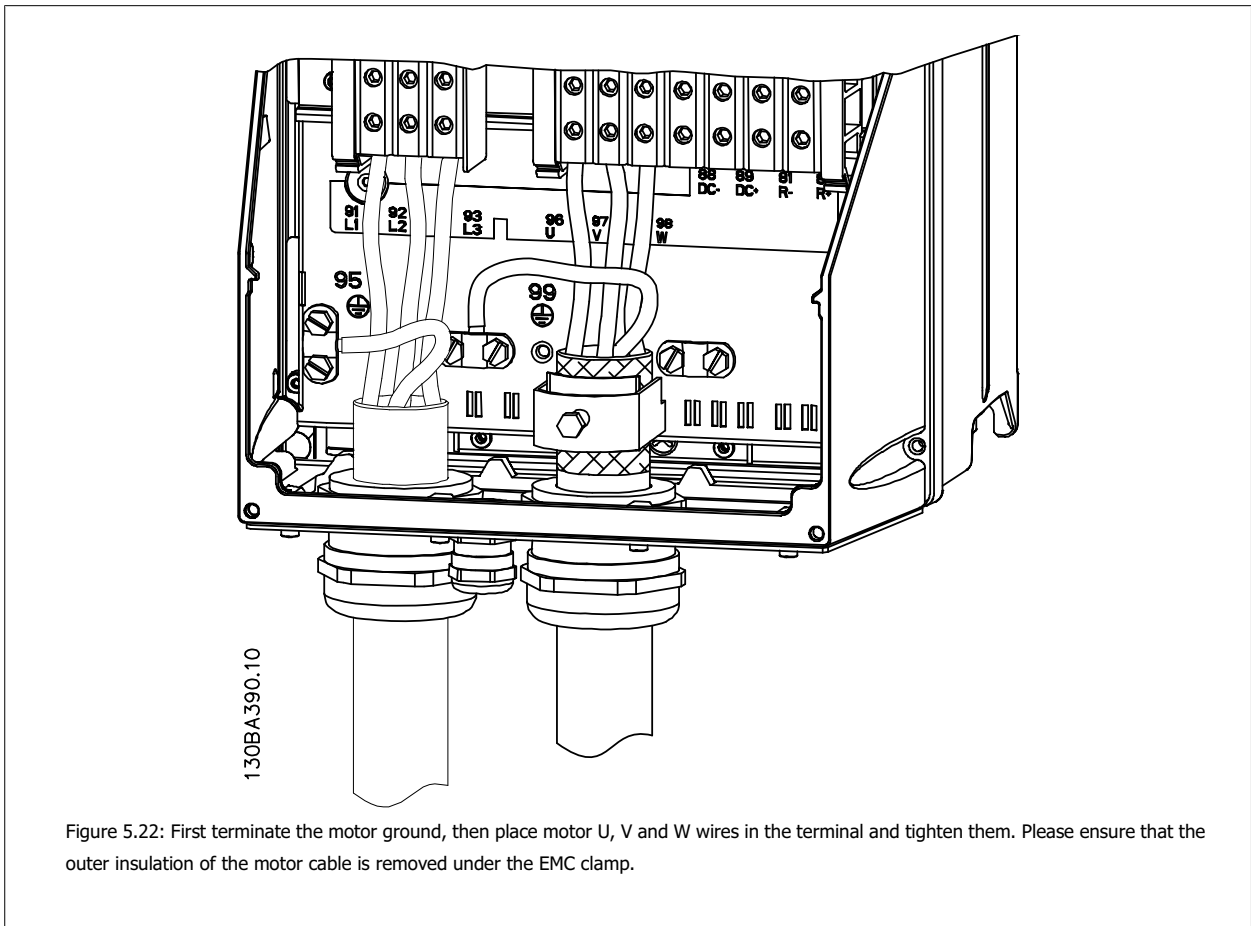


Figure 5.22: First terminate the motor ground, then place motor U, V and W wires in the terminal and tighten them. Please ensure that the outer insulation of the motor cable is removed under the EMC clamp.

**5.1.16 Motor Connection for C3 and C4**

**5**

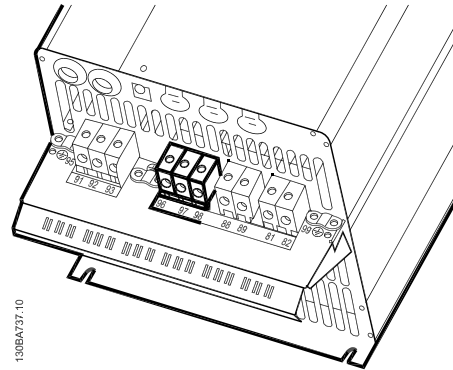


Figure 5.23: First terminate the motor ground, then place motor U, V and W wires into the appropriate terminals and tighten. Please ensure that the outer insulation of the motor cable is removed under the EMC clamp.

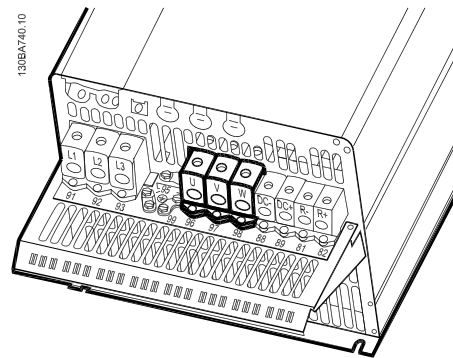


Figure 5.24: First terminate the motor ground, then place motor U, V and W wires into the appropriate terminals and tighten. Please ensure that the outer insulation of the motor cable is removed under the EMC clamp.

### 5.1.17 DC Bus Connection

The DC bus terminal is used for DC back-up, with the intermediate circuit being supplied from an external source.

Terminal numbers used: 88, 89

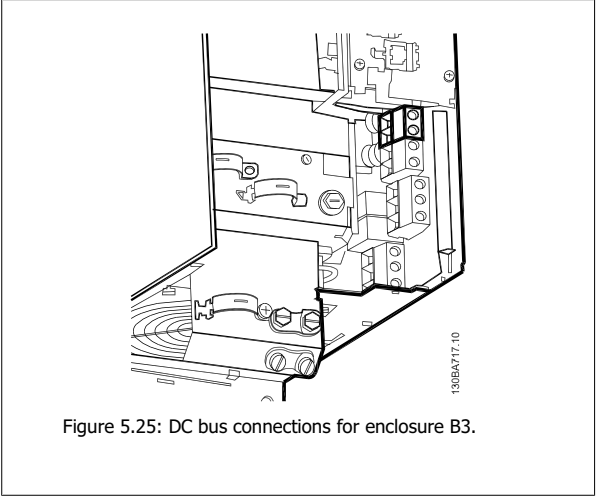


Figure 5.25: DC bus connections for enclosure B3.

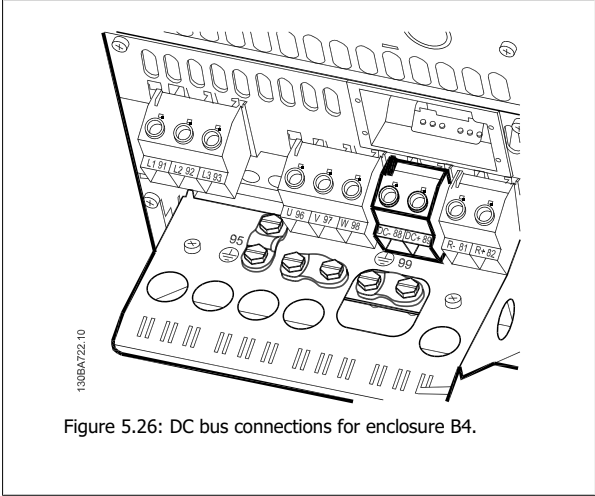


Figure 5.26: DC bus connections for enclosure B4.

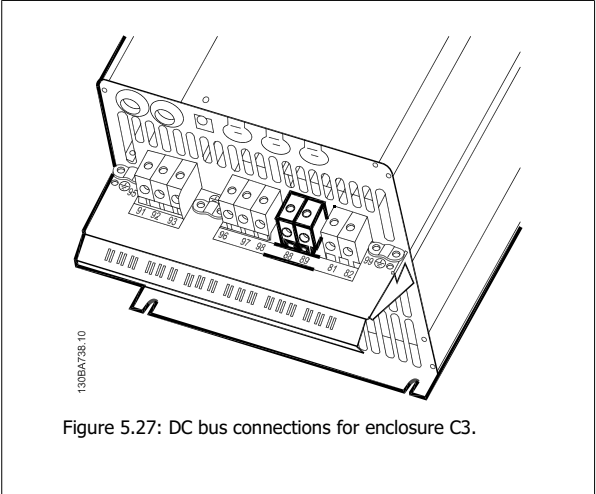


Figure 5.27: DC bus connections for enclosure C3.

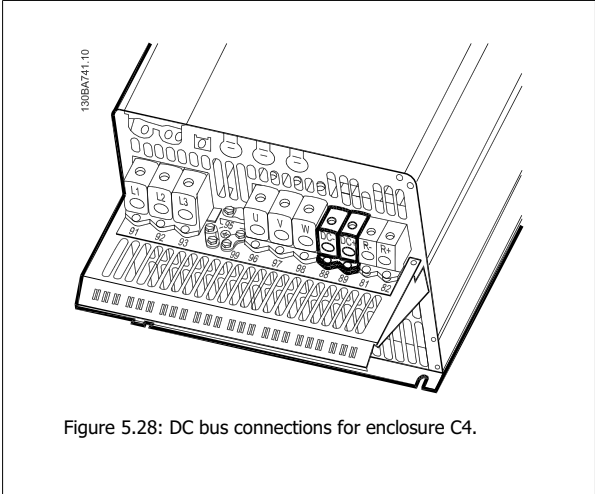


Figure 5.28: DC bus connections for enclosure C4.

Please contact Danfoss if you require further information.

### 5.1.18 Brake Connection Option

The connection cable to the brake resistor must be shielded/armored.

Brake resistor		
Terminal number	81	82
Terminals	R-	R+



**NOTE!**

Dynamic brake calls for extra equipment and safety considerations. For further information, please contact Danfoss.

5

1. Use cable clamps to connect the shield to the metal cabinet of the adjustable frequency drive and to the decoupling plate of the brake resistor.
2. Dimension the cross-section of the brake cable to match the brake current.



**NOTE!**

Voltages up to 975 V DC (@ 600 V AC) may occur between the terminals.

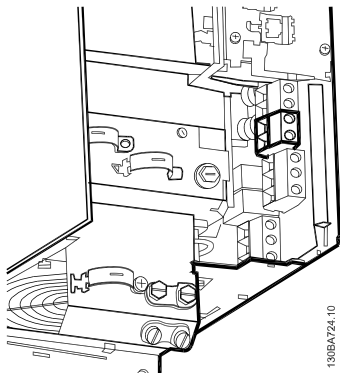


Figure 5.29: Brake connection terminal for B3.

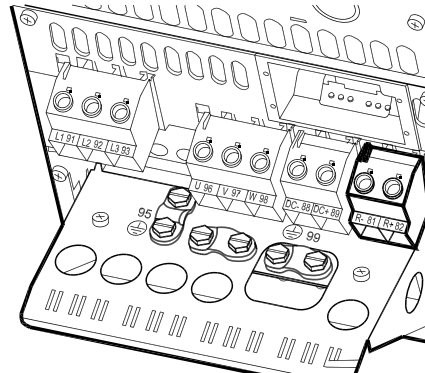


Figure 5.30: Brake connection terminal for B4.

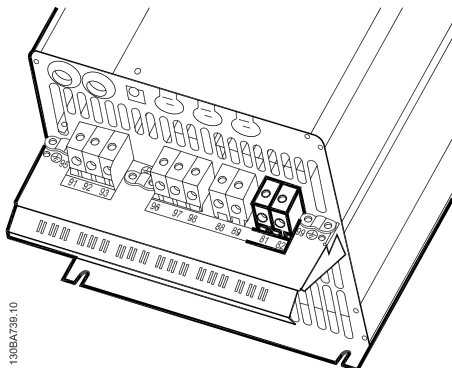


Figure 5.31: Brake connection terminal for C3.

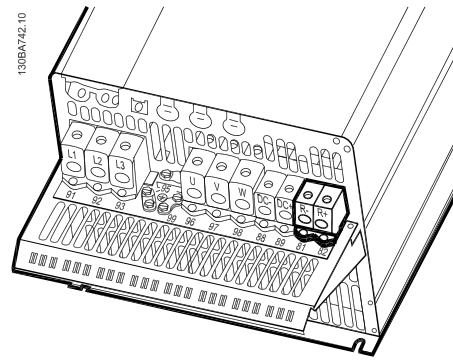


Figure 5.32: Brake connection terminal for C4.



**NOTE!**

If a short circuit in the brake IGBT occurs, prevent power dissipation in the brake resistor by using a line switch or contactor to disconnect the line power from the adjustable frequency drive. Only the adjustable frequency drive should control the contactor.



**NOTE!**

Place the brake resistor in an environment free of fire risk and ensure that no external objects can fall into the brake resistor through ventilation slots.

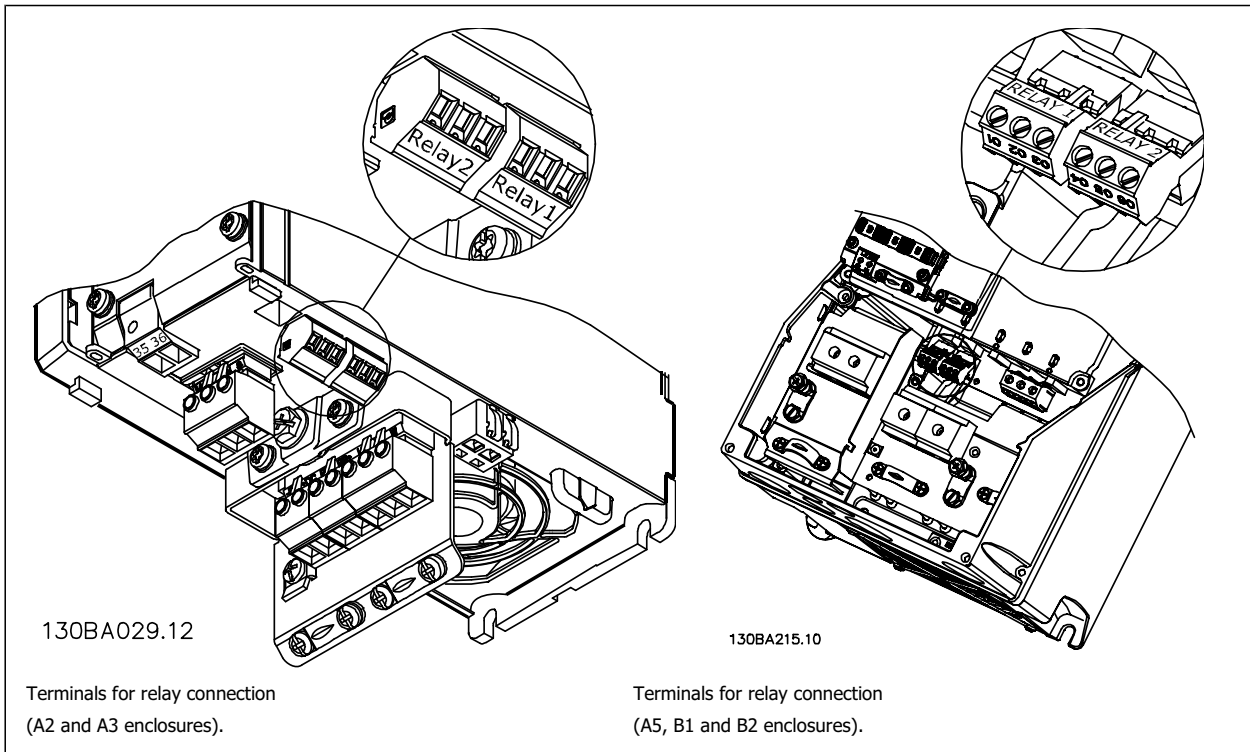
Do not cover ventilation slots and grids.

### 5.1.19 Relay Connection

To set relay output, see par. group 5-4\* Relays.

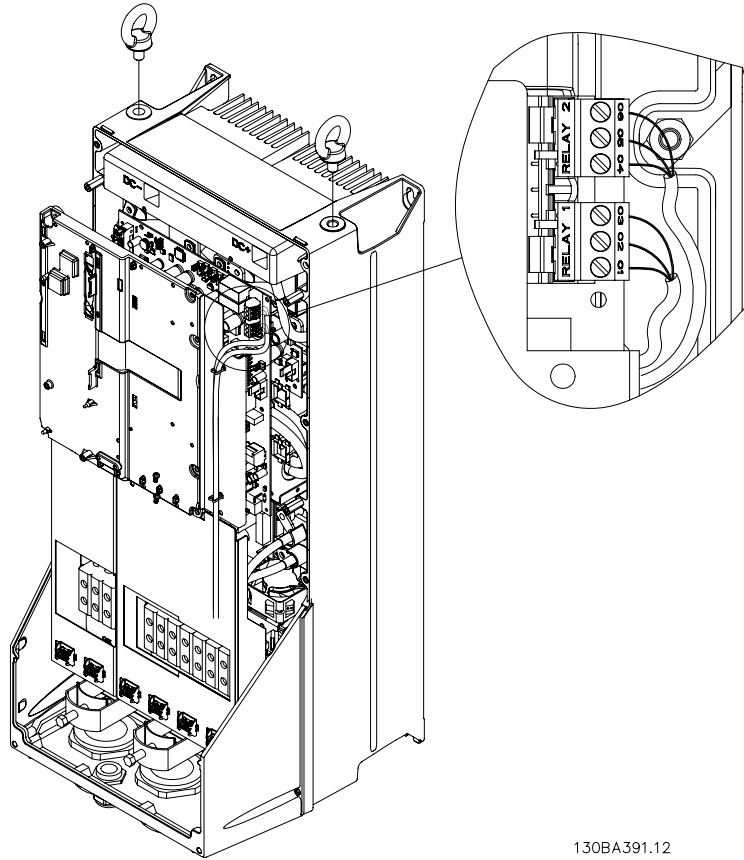
No.	01 - 02	make (normally open)
	01 - 03	break (normally closed)
	04 - 05	make (normally open)
	04 - 06	break (normally closed)

5



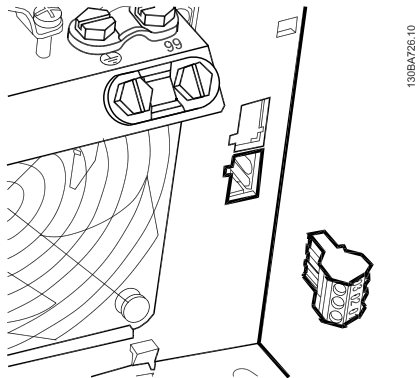


5



130BA391.12

Figure 5.33: Terminals for relay connection (C1 and C2 enclosures).  
The relay connections are shown in the cut-out with relay plugs (from the accessory bag) fitted.



130BA726-10

Figure 5.34: Terminals for relay connections for B3. Only one relay input is fitted from the factory. When the second relay is needed, remove the knock-out.

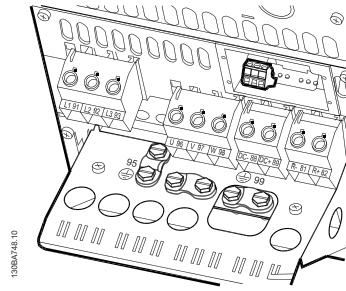


Figure 5.35: Terminals for relay connections for B4.

5

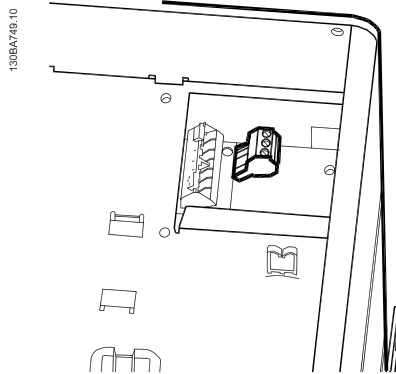


Figure 5.36: Terminals for relay connections for C3 and C4. Located in the upper right corner of the adjustable frequency drive.

### 5.1.20 Relay Output

#### Relay 1

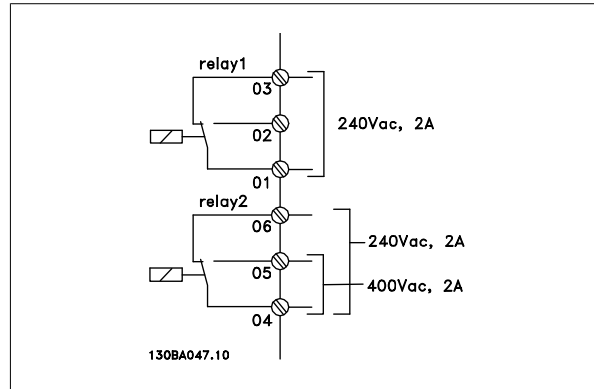
- Terminal 01: common
- Terminal 02: normal open 240 V AC
- Terminal 03: normal closed 240 V AC

Relay 1 and relay 2 are programmed in par. 5-40 *Function Relay*, par. 5-41 *On Delay, Relay*, and par. 5-42 *Off Delay, Relay*.

Additional relay outputs by using option module MCB 105.

#### Relay 2

- Terminal 04: common
- Terminal 05: normal open 400 V AC
- Terminal 06: normal closed 240 V AC



5

### 5.1.21 Wiring Example and Testing

The following section describes how to terminate and access control wires. For an explanation of the function, programming and wiring of the control terminals, please see chapter *How to program the adjustable frequency drive*.

### 5.1.22 Access to Control Terminals

All terminals to the control cables are located underneath the terminal cover on the front of the adjustable frequency drive. Remove the terminal cover with a screwdriver.



Figure 5.37: Access to control terminals for A2, A3, B3, B4, C3 and C4 enclosures

Remove front cover to access control terminals. When replacing the front cover, ensure proper fastening by applying a torque of 2 Nm.

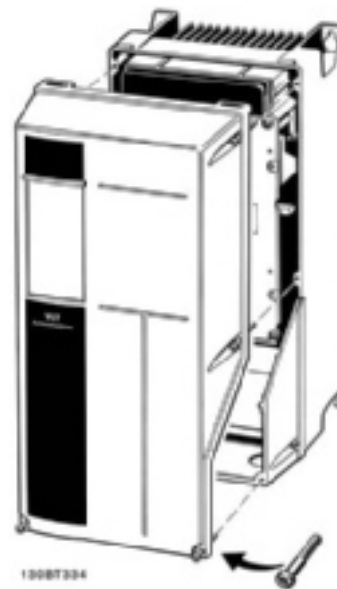


Figure 5.38: Access to control terminals for A5, B1, B2, C1 and C2 enclosures

### 5.1.23 Control Terminals

**Drawing reference numbers:**

1. 10-pole plug digital I/O.
2. 3-pole plug RS-485 bus.
3. 6-pole analog I/O.
4. USB connection.

5

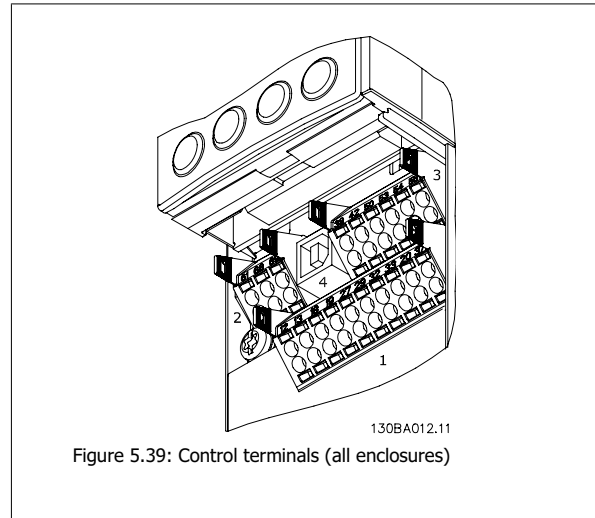


Figure 5.39: Control terminals (all enclosures)

### 5.1.24 Control Cable Clamp

1. Use a clamp from the accessory bag to connect the shield to the adjustable frequency drive decoupling plate for control cables.

See the section entitled *Grounding of Shielded/Armored Control Cables* for the correct termination of control cables.

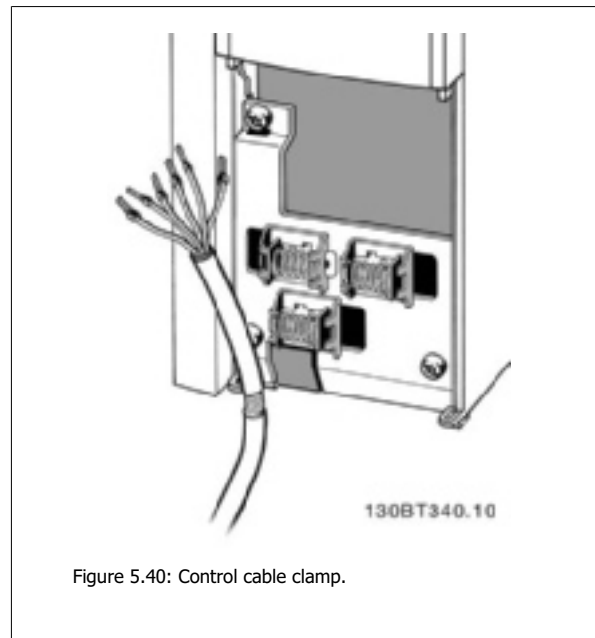


Figure 5.40: Control cable clamp.

### 5.1.25 Electrical Installation and Control Cables

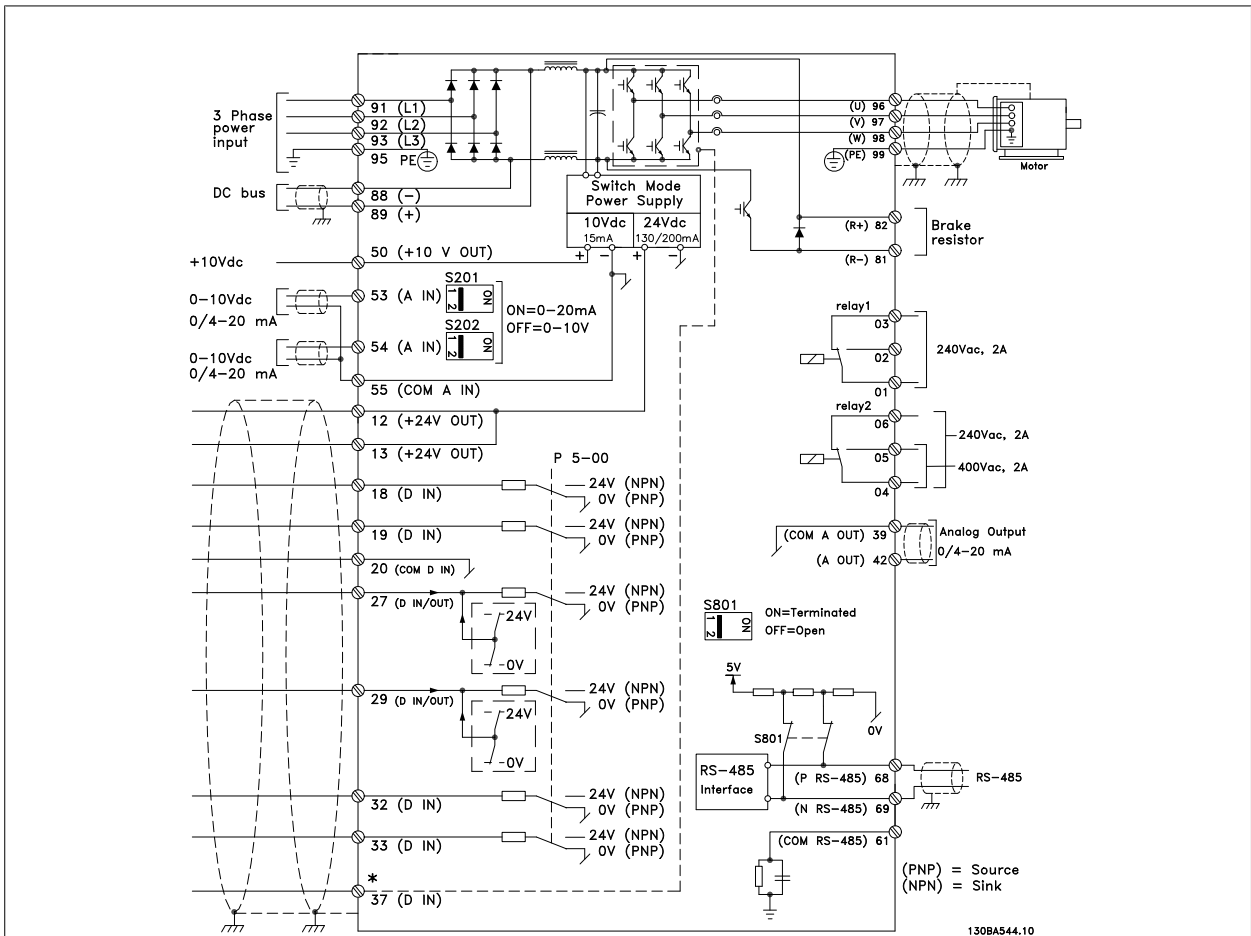


Figure 5.41: Diagram showing all electrical terminals. (Terminal 37 present for units with safe stop function only.)

Terminal number	Terminal description	Parameter number	Factory default
1+2+3	Terminal 1+2+3-Relay1	5-40	No operation
4+5+6	Terminal 4+5+6-Relay2	5-40	No operation
12	Terminal 12 Supply	-	+24 V DC
13	Terminal 13 Supply	-	+24 V DC
18	Terminal 18 Digital Input	5-10	Start
19	Terminal 19 Digital Input	5-11	No operation
20	Terminal 20	-	Common
27	Terminal 27 Digital Input/Output	5-12/5-30	Coast inverse
29	Terminal 29 Digital Input/Output	5-13/5-31	Jog
32	Terminal 32 Digital Input	5-14	No operation
33	Terminal 33 Digital Input	5-15	No operation
37	Terminal 37 Digital Input	-	Safe Stop
42	Terminal 42 Analog Output	6-50	Speed 0-HighLim
53	Terminal 53 Analog Input	3-15/6-1*/20-0*	Reference
54	Terminal 54 Analog Input	3-15/6-2*/20-0*	Feedback

Table 5.5: Terminal connections

Very long control cables and analog signals may, in rare cases and depending on the installation, result in 50/60 Hz ground loops due to noise from line power supply cables.

If this occurs, break the shield or insert a 100 nF capacitor between shield and chassis.

**NOTE!**

The common of digital / analog inputs and outputs should be connected to separate common terminals 20, 39, and 55. This will prevent ground current interference among groups. For example, it prevents switching on digital inputs from disturbing analog inputs.

**NOTE!**

Control cables must be shielded/armored.

### 5.1.26 How to Test Motor and Direction of Rotation

**!** Note that unintended motor start can occur; make sure no personnel or equipment is in danger!

Figure 5.42:  
**Step 1:** First, remove the insulation on both ends of a 1.97–2.76 in [50–70 mm] piece of wire.

Please follow these steps to test the motor connection and direction of rotation. Start with no power to the unit.

Figure 5.43:  
**Step 2:** Insert one end in terminal 27 using a suitable terminal screwdriver. (Note: For units with the Safe Stop function, the existing jumper between terminal 12 and 37 should not be removed for the unit to be able to run!)

Figure 5.44:  
**Step 3:** Insert the other end in terminal 12 or 13. (Note: For units with the Safe Stop function, the existing jumper between terminal 12 and 37 should not be removed for the unit to be able to run!)

Figure 5.45:  
**Step 4:** Power up the unit and press the [Off] button. In this state, the motor should not rotate. Press [Off] to stop the motor at any time. Note that the LED on the [OFF] button should be lit. If alarms or warnings are flashing, please see chapter 7 for more information.

Figure 5.46:  
**Step 5:** By pressing the [Hand on] button, the LED above the button should be lit and the motor may rotate.



5

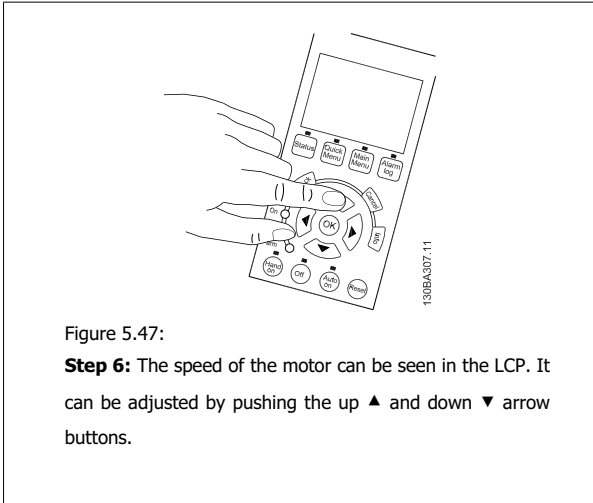


Figure 5.47:  
**Step 6:** The speed of the motor can be seen in the LCP. It can be adjusted by pushing the up ▲ and down ▼ arrow buttons.

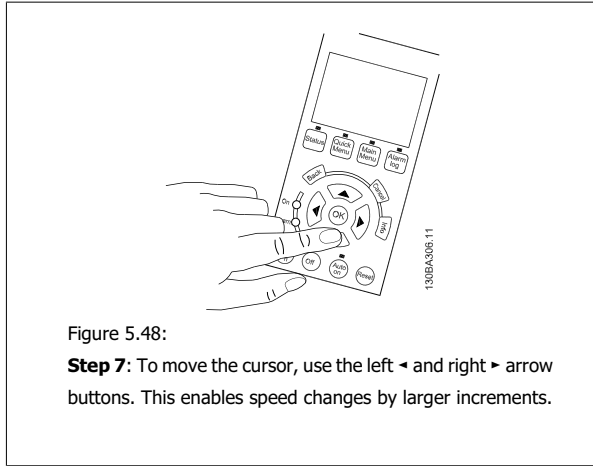


Figure 5.48:  
**Step 7:** To move the cursor, use the left ◀ and right ▶ arrow buttons. This enables speed changes by larger increments.

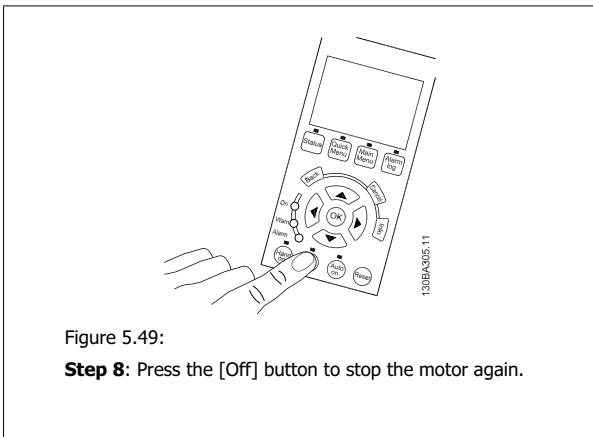


Figure 5.49:  
**Step 8:** Press the [Off] button to stop the motor again.

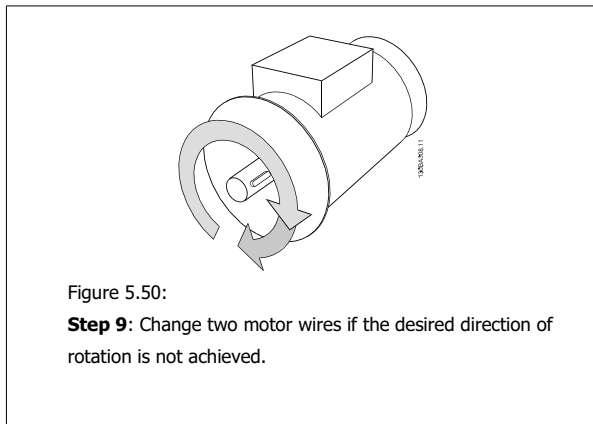



Figure 5.50:  
**Step 9:** Change two motor wires if the desired direction of rotation is not achieved.



Remove line power from the adjustable frequency drive before changing motor wires.

### 5.1.27 Switches S201, S202, and S801

Switches S201 (AI 53) and S202 (AI 54) are used to select a current (0-20 mA) or a voltage (0 to 10 V) configuration of the analog input terminals 53 and 54 respectively.

Switch S801 (BUS TER.) can be used to enable termination on the RS-485 port (terminals 68 and 69).

Please note that the switches may be covered by an option, if so equipped.

**Default setting:**

S201 (AI 53) = OFF (voltage input)

S202 (AI 54) = OFF (voltage input)

S801 (Bus termination) = OFF



Figure 5.51: Switches location.

## 5.2 Final Optimization and Test

### 5.2.1 Final Optimization and Test

To optimize motor shaft performance and optimize the adjustable frequency drive for the connected motor and installation, please follow these steps: Ensure that the adjustable frequency drive and the motor are connected, and power is applied to the adjustable frequency drive.

**NOTE!**  
Before power-up, ensure that connected equipment is ready for use.

**Step 1. Locate motor nameplate**

**NOTE!**  
The motor is either star- (Y) or delta-connected (Δ). This information is located on the motor nameplate data.

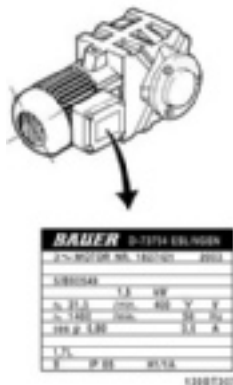


Figure 5.52: Motor nameplate example

5

**Step 2. Enter the motor nameplate data in the following parameter list.**

To access the list, first press [QUICK MENU] key, then select "Q2 Quick Set-up".

1.	Motor Power [kW] or Motor Power [HP]	par. 1-20 par. 1-21
2.	Motor Voltage	par. 1-22
3.	Motor Frequency	par. 1-23
4.	Motor Current	par. 1-24
5.	Motor Nominal Speed	par. 1-25

Table 5.6: Motor related parameters

**Step 3. Activate Automatic Motor Adaptation (AMA)**

Performing an AMA ensures best possible performance. An AMA automatically takes measurements from the specific motor connected and compensates for installation variances.

1. Connect terminal 27 to terminal 12 or use [MAIN MENU] and set Terminal 27 par. 5-12 to *No operation* (par. 5-12 [0])
2. Press [QUICK MENU], select "Q2 Quick Set-up", scroll down to AMA par. 1-29.
3. Press [OK] to activate the AMA par. 1-29.
4. Choose between complete or reduced AMA. If the sine wave filter is mounted, run only reduced AMA, or remove the sine wave filter during the AMA procedure.
5. Press the [OK] key. The display should show "Press [Hand on] to start."
6. Press the [Hand on] key. A progress bar indicates if the AMA is in progress.

**Stop the AMA during operation**

1. Press the [OFF] key. The adjustable frequency drive enters into alarm mode and the display shows that the AMA was terminated by the user.

**Successful AMA**

1. The display shows "Press [OK] to finish AMA".
2. Press the [OK] key to exit the AMA state.

**Unsuccessful AMA**

1. The adjustable frequency drive enters into alarm mode. A description of the alarm can be found in the *Troubleshooting* section.
2. "Report Value" in the [Alarm Log] shows the last measuring sequence carried out by the AMA before the adjustable frequency drive entered alarm mode. This number, along with the description of the alarm, will assist in troubleshooting. If contacting Danfoss Service, make sure to mention the number and alarm description.



**NOTE!**

An unsuccessful AMA is often caused by incorrectly entered motor nameplate data or too big of a difference between the motor and the adjustable frequency drive power sizes.

**Step 4. Set speed limit and ramp time**

Set up the desired limits for speed and ramp time.

Minimum Reference	par. 3-02
Maximum Reference	par. 3-03

Motor Speed Low Limit	par. 4-11 or 4-12
Motor Speed High Limit	par. 4-13 or 4-14

Ramp 1 Ramp-up Time [s]	par. 3-41
Ramp 1 Ramp-down Time 1 [s]	par. 3-42

**5**

## 6 Commissioning and Application Examples

### 6.1 Quick Set-up

#### 6.1.1 Quick Menu Mode

The GLCP provides access to all parameters listed under the Quick Menus. To set parameters using the [Quick Menu] button:

Pressing [Quick Menu] the list indicates the different areas contained in the quick menu.

##### Efficient parameter set-up for water applications

The parameters can easily be set up for the vast majority of the water and wastewater applications only by using the [Quick Menu].

**The best way to set parameters using the [Quick Menu] is by following the steps below:**

1. Press [Quick Set-up] for selecting basic motor settings, ramp times, etc.
2. Press [Function Set-ups] for setting up the required functionality of the adjustable frequency drive - if not already covered by the settings in [Quick Set-up].
3. Choose between *General Settings*, *Open-loop Settings* and *Closed-loop Settings*.

It is recommended to do the set-up in the order listed.

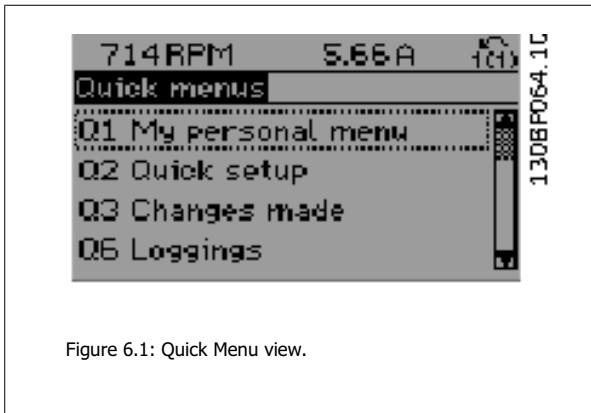


Figure 6.1: Quick Menu view.

Par.	Designation	[Units]
0-01	Language	
1-20	Motor Power	[kW]
1-22	Motor Voltage	[V]
1-23	Motor Frequency	[Hz]
1-24	Motor Current	[A]
1-25	Motor Nominal Speed	[RPM]
3-41	Ramp 1 Ramp-up Time	[s]
3-42	Ramp 1 Ramp-down Time	[s]
4-11	Motor Speed Low Limit	[RPM]
4-13	Motor Speed High Limit	[RPM]
1-29	Automatic Motor Adaptation (AMA)	

Table 6.1: Quick Set-up parameters. Please see section *Commonly Used Parameters - Explanations*

If *No Operation* is selected in terminal 27, no connection to +24 V on terminal 27 is necessary to enable start.

If *Coast Inverse* (factory default value) is selected in Terminal 27, a connection to +24V is necessary to enable start.

**NOTE!**

For detailed parameter descriptions, please see the following section on *Commonly Used Parameters - Explanations*.

### 6.2.1 Start/Stop

Terminal 18 = start/stop par. 5-10 [8] *Start*

Terminal 27 = No operation par. 5-12 [0] *No operation* (Default *coast inverse*)

Par. 5-10 *Digital Input*, Terminal 18 = *Start* (default)

Par. 5-12 *Digital Input*, Terminal 27 = *coast inverse* (default)

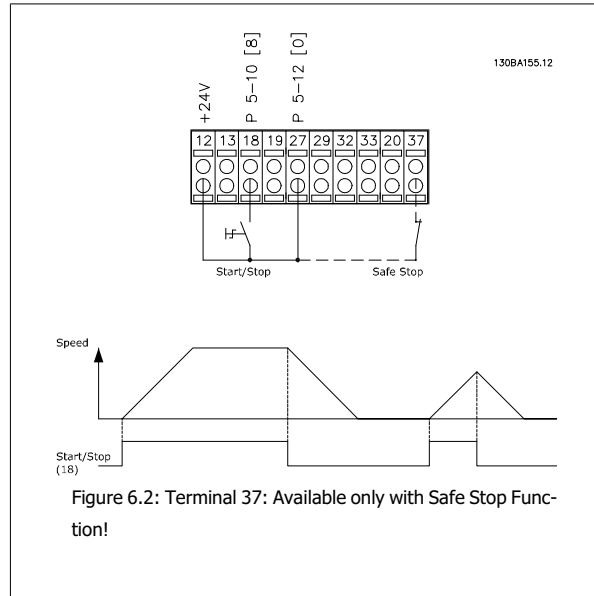


Figure 6.2: Terminal 37: Available only with Safe Stop Function!

### 6.2.2 Closed-loop Wiring

Terminal 12 /13: +24 V DC

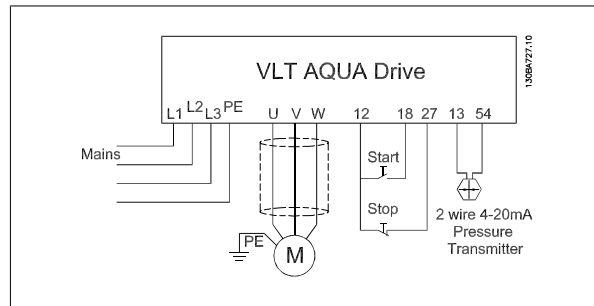
Terminal 18: Start par. 5-18 [8] Start (Default)

Terminal 27: Coast par. 5-12 [2] coast inverse (Default)

Terminal 54: Analog input

L1-L3: Line power terminals

U,V and W: Motor terminals



### 6.2.3 Submersible Pump Application

The system consists of a submersible pump controlled by a Danfoss VLT AQUA Drive and a pressure transmitter. The transmitter gives a 4-20 mA feedback signal to the VLT AQUA Drive, which keeps a constant pressure by controlling the speed of the pump. To design a drive for a submersible pump application, there are a few important issues to take into consideration. Therefore, the drive used must be chosen according to motor current.

1. The motor is a what is known as a "Can motor" with a stainless steel can between the rotor and stator. There is a larger and a more magnetic resistant air-gap than on a normal motor hence a weaker field which results in the motor being designed with a higher rated current than a norm motor with similar rated power.
2. The pump contains thrust bearings which are damaged when run below minimum speed, which is normally 30 Hz.
3. The motor reactance is nonlinear in submersible pump motors and therefore Automatic Motor Adaption (AMA) may not be possible. However, normally submersible pumps are operated with very long motor cables that might eliminate the nonlinear motor reactance and enable the drive to perform AMA. If AMA fails, the motor data can be set from parameter group 1-3\* (see motor datasheet). Be aware that if an AMA has been successful, the drive will compensate for voltage drop in the long motor cables, so if the advanced motor data are set manually, the length of the motor cable must be taken into considerations to optimize system performance.
4. It is important that the system be operated with a minimum of wear and tear of the pump and motor. A Danfoss Sine-Wave filter can lower the motor insulation stress and increase lifetime (check actual motor insulation and the adjustable frequency drive du/dt specification). It is recommended to use a filter to reduce the need for service.
5. EMC performance can be difficult to achieve due to the fact that the special pump cable, which is able to withstand the wet conditions in the well, is normally unshielded. A solution could be to use a shielded cable above the well and fix the screen to the well pipe if it is made of steel (can also be made of plastic). A Sine-Wave filter will also reduce the EMI from unshielded motor cables.

The special "can motor" is used due to the wet installation conditions. The drive needs to be designed for the system according to output current to be able to run the motor at nominal power.

To prevent damage to the thrust bearings of the pump, it is important to ramp the pump from stop to min. speed as quickly as possible. Well-known manufacturers of submersible pumps recommend that the pump be ramped to a min. speed (30 Hz) in max. 2-3 seconds. The new VLT® AQUA Drive is designed with initial and final ramp for these applications. The initial and final ramps are 2 individual ramps, where Initial Ramp, if enabled, will ramp the motor from stop to min. speed and automatically switch to normal ramp, when min. speed is reached. Final ramp will do the opposite from min. speed to stop in a stop situation.

Pipe-fill mode can be enabled to prevent water hammering. The Danfoss adjustable frequency drive is capable of filling vertical pipes using the PID controller to slowly ramp up the pressure with a user specified rate (units/sec). If enabled, the drive will enter pipe fill mode, when it reaches min. speed after startup. The pressure will slowly be ramped up until it reaches a user-specified filled setpoint, after which the drive automatically disables pipe fill mode and continues in normal closed-loop operation.

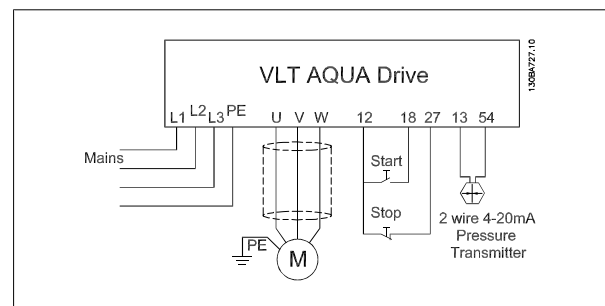
This feature is designed for irrigation applications.

#### Electrical Wiring

Typical parameter settings (typical/recommended settings in brackets.)

Parameters:	
Motor Rated Power	Par. 1-20 / par. 1-21
Motor Rated Voltage	Par. 1-22
Motor Current	Par. 1-24
Motor Rated Speed	Par. 1-28
Enable Reduced Automatic Motor Adaptation (AMA in par. 1-29)	

**NOTE!**  
Note the analog input 2, (terminal (54) format must be set to mA. (switch 202).



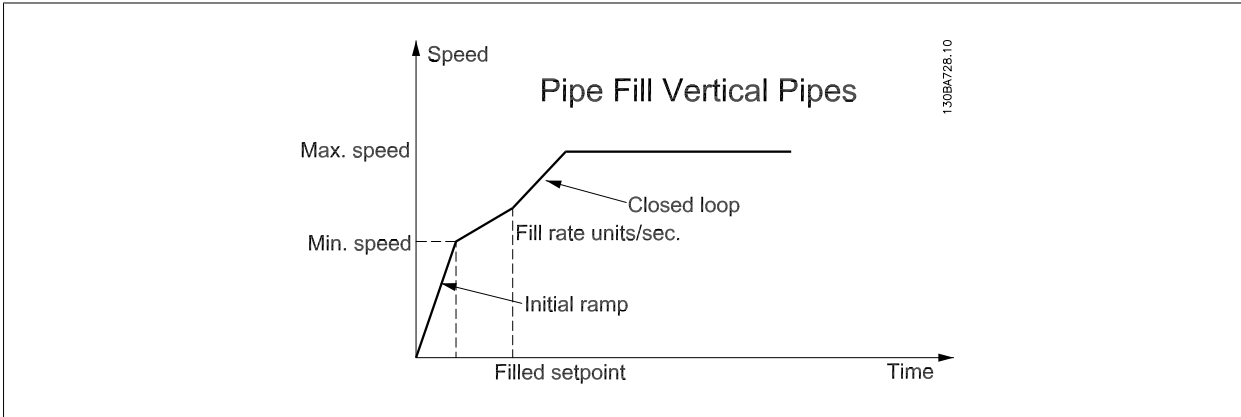


Min. Reference	Par. 3-01	(30 Hz)
Max. Reference	Par. 3-02	(50/60 Hz)
Initial Ramp-up Time	Par. 3-84	(2 sec.)
Final Ramp-down Time	Par. 3-88	(2 sec.)
Normal Ramp-up Time	Par. 3-41	(8 sec. depending on size)
Normal Ramp-down Time	Par. 3-42	(8 sec. depending on size)
Motor Min. Speed	Par. 4-11	(30 Hz)
Motor Max. Speed	Par. 4-13	(50/60 Hz)

Use the "Closed-loop" wizard under "Quick Menu\_Funtion\_Setup" to easily set up the feedback settings in the PID controller.

<b>Pipe Fill Mode</b>		
Pipe Fill Enable	Par. 29-00	
Pipe Fill Rate	Par. 29-04	(Feedback units/sec.)
Filled Setpoint	Par. 29-05	(Feedback units)

6



## 7 How to Operate the Adjustable Frequency Drive

### 7.1 Ways of Operation

#### 7.1.1 Ways of Operation

**The Adjustable Frequency Drive can be Operated in 3 Ways:**

1. Graphical Local Control Panel (GLCP), see 6.1.2
2. Numeric Local Control Panel (NLCP), see 6.1.3
3. RS-485 serial communication or USB, both for PC connection, see 6.1.4

If the adjustable frequency drive is equipped with the serial communication option, please refer to the relevant documentation.

#### 7.1.2 How to Operate the Graphical LCP (GLCP)

The following instructions are valid for the GLCP (LCP 102).

**The GLCP is divided into four functional groups:**

1. Graphical display with Status lines.
2. Menu keys and indicator lights (LEDs) - selecting mode, changing parameters and switching between display functions.
3. Navigation keys and indicator lights (LEDs).
4. Operation keys and indicator lights (LEDs).

**Graphical display:**

The LCD display is back lit with a total of 6 alpha-numeric lines. All data is displayed on the LCP, which can show up to five operating variables while in [Status] mode.

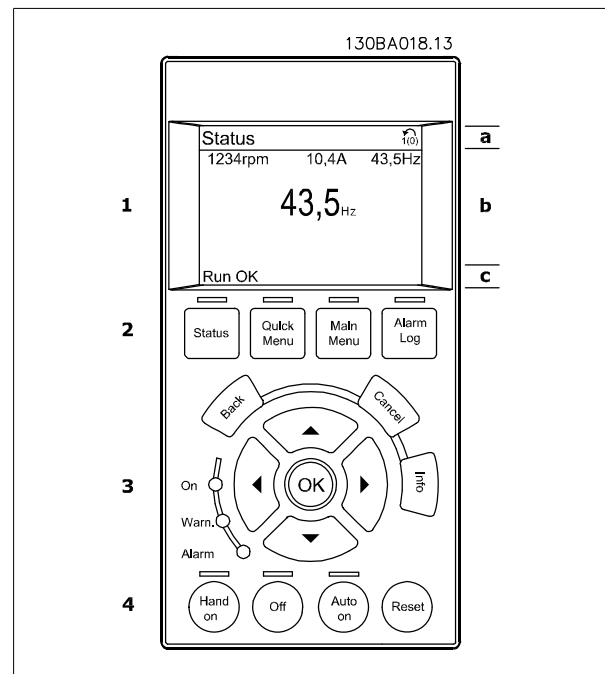
**Display lines:**

- a. **Status line:** Status messages displaying icons and graphics.
- b. **Line 1-2:** Operator data lines displaying data and variables defined or chosen by the user. By pressing the [Status] key, up to one extra line can be added.
- c. **Status line:** Status messages displaying text.

The display is divided into 3 sections:

**Top section (a)**

shows the status when in status mode, or up to two variables when not in status mode and in the case of an alarm/warning.



The number of the Active Set-up (selected as the Active Set-up in par. 0-10) is shown. When programming in another set-up than the Active Set-up, the number of the set-up being programmed appears to the right in brackets.

**Middle section (b)**

shows up to 5 variables with related unit, regardless of status. In the case of an alarm/warning, the warning is shown instead of the variables.

It is possible to toggle between three status readout displays by pressing the [Status] key.

Operating variables with different formatting are shown in each status screen - see below.

Several values or measurements can be linked to each of the displayed operating variables. The values/measurements to be displayed can be defined via par. 0-20, 0-21, 0-22, 0-23, and 0-24, which can be accessed via [QUICK MENU], "Q3 Function Set-ups", "Q3-1 General Settings", "Q3-11 Display Settings".

Each value / measurement readout parameter selected in par. 0-20 to par. 0-24 has its own scale and number of digits after a possible decimal point. Larger numeric values are displayed with few digits after the decimal point.

Ex.: Current readout  
5.25 A; 15.2 A 105 A.

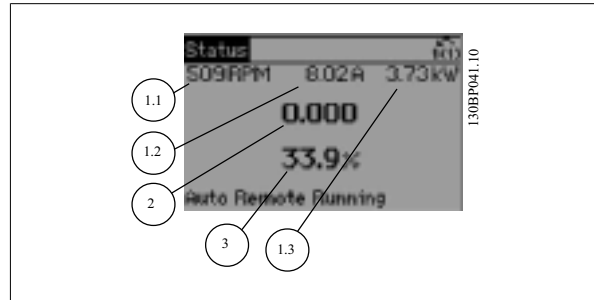
7

**Status display I**

This read-out state is standard after start-up or initialization.

Use [INFO] to obtain information about the value/measurement linked to the displayed operating variables (1.1, 1.2, 1.3, 2, and 3).

See the operating variables shown in the display in this illustration. 1.1, 1.2 and 1.3 are shown in small size. 2 and 3 are shown in medium size.

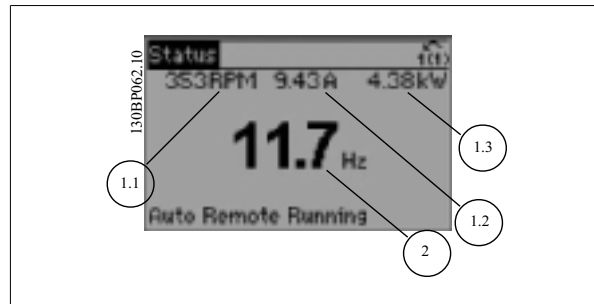


**Status display II**

See the operating variables (1.1, 1.2, 1.3, and 2) shown in the display in this illustration.

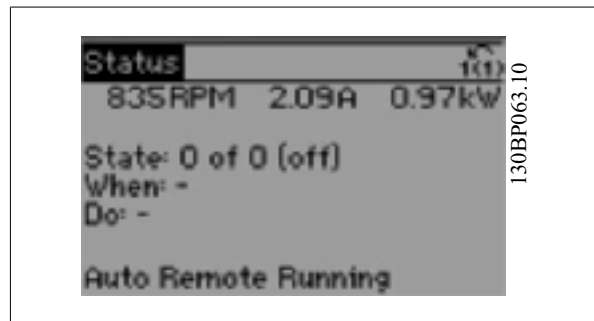
In the example, Speed, Motor current, Motor power and Frequency are selected as variables in the first and second lines.

1.1, 1.2 and 1.3 are shown in small size. 2 is shown in large size.



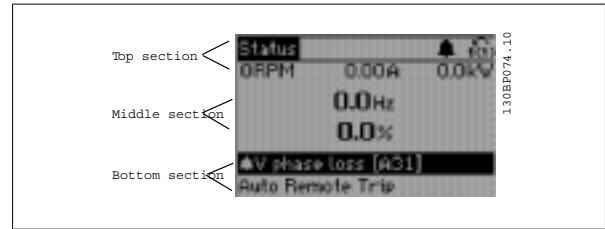
**Status display III:**

This state displays the event and action of the Smart Logic Control. For further information, see the section *Smart Logic Control*.



**Bottom section**

always shows the state of the adjustable frequency drive in status mode.



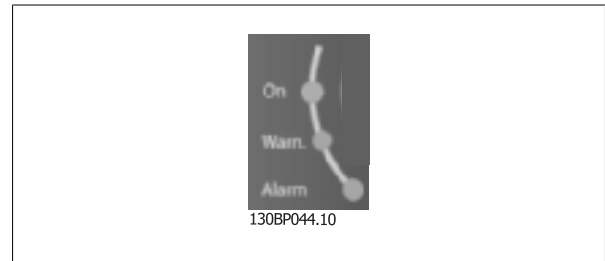
**Display Contrast Adjustment**

Press [status] and [▲] for darker display  
Press [status] and [▼] for brighter display

**Indicator lights (LEDs):**

If certain threshold values are exceeded, the alarm and/or warning LED lights up. A status and alarm text appear on the control panel.  
The On LED is activated when the adjustable frequency drive receives power from AC line voltage, a DC bus terminal, or an external 24 V supply. At the same time, the back light is on.

- Green LED/On: Control section is working.
- Yellow LED/Warn.: Indicates a warning.
- Flashing Red LED/Alarm: Indicates an alarm.



**GLCP keys**

**Menu keys**

The menu keys are divided into functions. The keys below the display and indicator lamps are used for parameter set-up, including choice of display indication during normal operation.



**[Status]**

Indicates the status of the adjustable frequency drive and/or the motor. Three different readouts can be chosen by pressing the [Status] key: 5 line readouts, 4 line readouts or Smart Logic Control.

Use [Status] for selecting the mode of display or for changing back to display mode from either the quick menu mode, main menu mode or alarm mode. Also use the [Status] key to toggle single or double readout mode.

**[Quick Menu]**

Allows quick set-up of the adjustable frequency drive. **The most common functions can be programmed here.**

**The [Quick Menu] consists of:**

- **Q1: My Personal Menu**
- **Q2: Quick Set-up**
- **Q3: Function Set-ups**
- **Q5: Changes Made**
- **Q6: Loggings**

The function set-up provides quick and easy access to all parameters required for the majority of water and wastewater applications including variable torque, constant torque, pumps, dosing pumps, well pumps, booster pumps, mixer pumps, aeration blowers and other pump and fan applications. Among other features, it also includes parameters for selecting which variables to display on the LCP, digital preset speeds, scaling of analog references, closed-loop single zone and multi-zone applications and specific functions related to water and wastewater applications.

The quick menu parameters can be accessed immediately unless a password has been created via par. 0-60, 0-61, 0-65 or 0-66. It is possible to switch directly between Quick Menu mode and main menu mode.

**[Main Menu]**

is used for programming all parameters.

The main menu parameters can be accessed immediately unless a password has been created via par. 0-60, 0-61, 0-65 or 0-66. For the majority of water and wastewater applications it is not necessary to access the main menu parameters, but instead the quick menu, quick set-up and function set-ups provide the simplest and quickest access to the typical required parameters.

It is possible to switch directly between Main Menu mode and quick menu mode.

Parameter shortcut can be carried out by pressing down the **[Main Menu]** key for 3 seconds. The parameter shortcut allows direct access to any parameter.

**[Alarm Log]**

displays an alarm list of the five latest alarms (numbered A1-A5). To obtain additional details about an alarm, use the arrow keys to navigate to the alarm number and press [OK]. Information is displayed about the condition of the adjustable frequency drive before it enters alarm mode.

**[Back]**

reverts to the previous step or layer in the navigation structure.

**[Cancel]**

the last change or command will be canceled as long as the display has not been changed.

**[Info]**

displays information about a command, parameter, or function in any display window. [Info] provides detailed information when needed. Exit Info mode by pressing either [Info], [Back], or [Cancel].

7

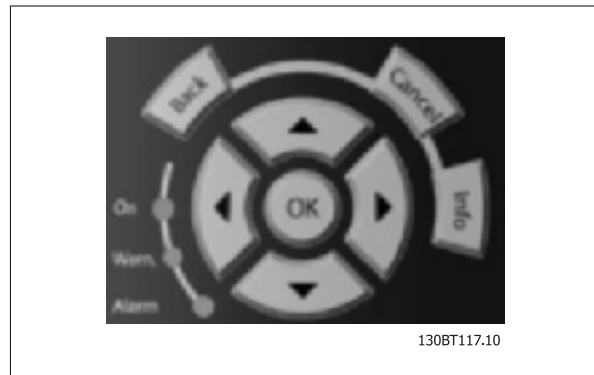


**Navigation Keys**

The four navigation arrows are used to navigate between the different choices available in [Quick Menu], [Main Menu] and [Alarm Log]. Use the keys to move the cursor.

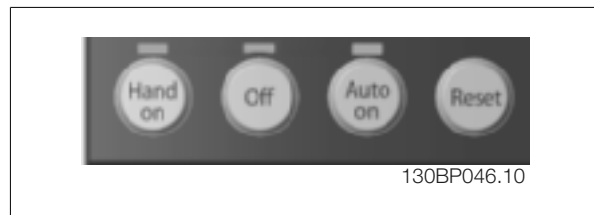
**[OK]**

is used for choosing a parameter marked by the cursor and for enabling the change of a parameter.



**Operation Keys**

for local control are found at the bottom of the control panel.



**[Hand On]**

enables control of the adjustable frequency drive via the GLCP. [Hand on] also starts the motor, and makes it possible to give the motor speed reference using the arrow keys. The key can be *Enabled* [1] or *Disabled* [0] via par. 0-40 [Hand on] Key on LCP.

**The following control signals will still be active when [Hand on] is activated:**

- [Hand on] - [Off] - [Auto on]
- Reset
- Coasting stop inverse (motor coasting to stop)
- Reversing
- Set-up select lsb - Set-up select msb
- Stop command from serial communication
- Quick stop
- DC brake



**NOTE!**

External stop signals activated by means of control signals or a serial bus will override a "start" command via the LCP.

**[Off]**

stops the connected motor. The key can be *Enabled* [1] or *Disabled* [0] via par. 0-41 [Off] key on LCP. If no external stop function is selected and the [Off] key is inactive, the motor can only be stopped by disconnecting the line power supply.

**[Auto On]**

enables the adjustable frequency drive to be controlled via the control terminals and/or serial communication. When a start signal is applied on the control terminals and/or the bus, the adjustable frequency drive will start. The key can be *Enabled* [1] or *Disabled* [0] via par. 0-42 [Auto on] key on LCP.



**NOTE!**

An active HAND-OFF-AUTO signal via the digital inputs has higher priority than the control keys [Hand on] – [Auto on].

**[Reset]**

is used for resetting the adjustable frequency drive after an alarm (trip). The key can be *Enabled* [1] or *Disabled* [0] via par. 0-43 Reset Keys on LCP.

**The parameter shortcut**

can be carried out by holding down the [Main Menu] key for 3 seconds. The parameter shortcut allows direct access to any parameter.

### 7.1.3 How to Operate the Numeric LCP (NLCP)

The following instructions are valid for the NLCP (LCP 101).

**The control panel is divided into four functional groups:**

1. Numeric display.
2. Menu key and LEDs - changing parameters and switching between display functions.
3. Navigation keys and LEDs.
4. Operation keys and LEDs.



**NOTE!**

Parameter copy is not possible with Numeric Local Control Panel (LCP101).

**Select one of the following modes:**

**Status Mode:** Displays the status of the adjustable frequency drive or the motor.

If an alarm occurs, the NLCP automatically switches to status mode.

A number of alarms can be displayed.

**Quick Set-up or Main Menu Mode:** Display parameters and parameter settings.

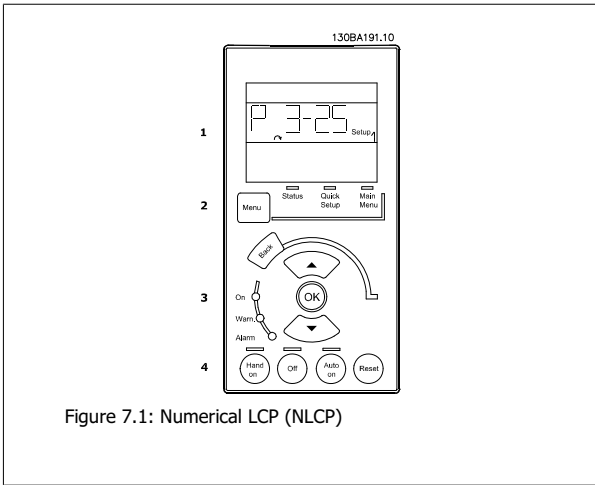


Figure 7.1: Numerical LCP (NLCP)

7

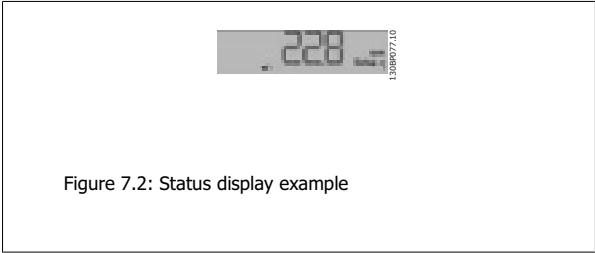


Figure 7.2: Status display example

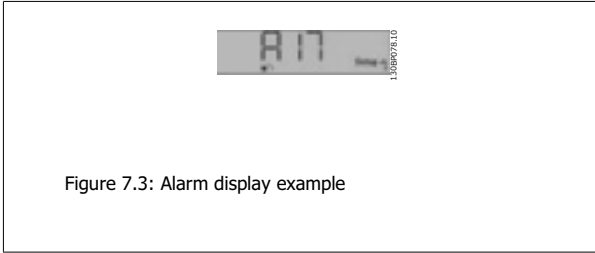


Figure 7.3: Alarm display example

**LEDs:**

- Green LED/On: Indicates if control section is on.
- Yellow LED/Wrn.: Indicates a warning.
- Flashing red LED/Alarm: Indicates an alarm.

**Menu key**

Select one of the following modes:

- Status
- Quick Set-up
- Main Menu

**Main Menu**

is used for programming all parameters.

The parameters can be accessed immediately unless a password has been created via par. 0-60 *Main Menu Password*, par. 0-61 *Access to Main Menu w/o Password*, par. 0-65 *Personal Menu Password* or par. 0-66 *Access to Personal Menu w/o Password*.

**Quick Set-up** is used to set up the adjustable frequency drive using only the most essential parameters.

The parameter values can be changed using the up/down arrows when the value is flashing.

Select the main menu by pressing the [Menu] key a number of times until the main menu LED is lit.

Select the parameter group [xx-\_\_] and press [OK]

Select the parameter [\_\_-xx] and press [OK]

If the parameter is an array parameter, select the array number and press [OK]

Select the wanted data value and press [OK]

**Navigation keys**

**[Back]**

for stepping backwards

**Arrow [▲] [▼]**

keys are used for navigating between parameter groups, parameters and within parameters.

**[OK]**

is used for choosing a parameter marked by the cursor and for enabling the change of a parameter.

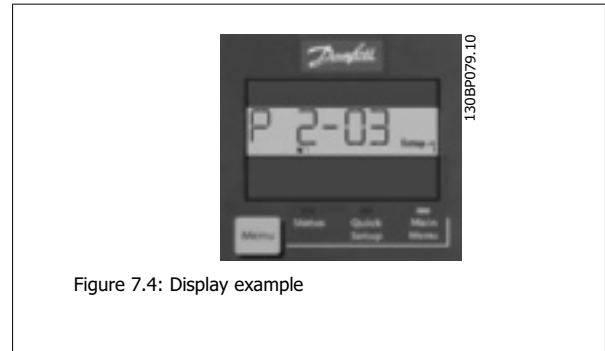


Figure 7.4: Display example

**Operation keys**

Keys for local control are found at the bottom of the control panel.

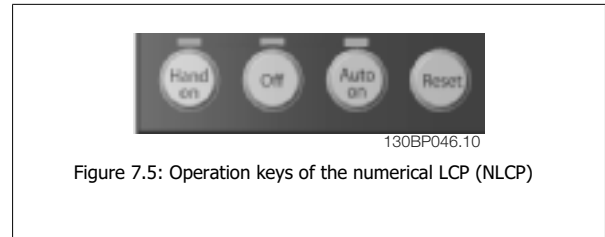


Figure 7.5: Operation keys of the numerical LCP (NLCP)

**[Hand on]**

enables control of the adjustable frequency drive via the LCP. [Hand on] also starts the motor and it is now possible to enter the motor speed data by means of the arrow keys. The key can be *Enabled* [1] or *Disabled* [0] via par. 0-40 [Hand on] Key on LCP.

External stop signals activated by means of control signals or a serial bus will override a 'start' command via the LCP.

**The following control signals will still be active when [Hand on] is activated:**

- [Hand on] - [Off] - [Auto on]
- Reset
- Coasting stop inverse
- Reversing
- Set-up select lsb - Set-up select msb
- Stop command from serial communication
- Quick stop
- DC brake


**[Off]**

stops the connected motor. The key can be *Enabled* [1] or *Disabled* [0] via par. 0-41 [Off] Key on LCP.

If no external stop function is selected and the [Off] key is inactive, the motor can be stopped by disconnecting the line power supply.

**[Auto on]**

enables the adjustable frequency drive to be controlled via the control terminals and/or serial communication. When a start signal is applied on the control terminals and/or the bus, the adjustable frequency drive will start. The key can be *Enabled* [1] or *Disabled* [0] via par. 0-42 [Auto on] Key on LCP.



**NOTE!**  
An active HAND-OFF-AUTO signal via the digital inputs has higher priority than the control keys [Hand on] [Auto on].

**[Reset]**

is used for resetting the adjustable frequency drive after an alarm (trip). The key can be *Enabled* [1] or *Disabled* [0] via par. 0-43 [Reset] Key on LCP.



### 7.1.4 Changing Data

1. Press the [Quick Menu] or [Main Menu] key.
2. Use [▲] and [▼] keys to find parameter group to edit.
3. Press the [OK] key.
4. Use [▲] and [▼] keys to find parameter to edit.
5. Press the [OK] key.
6. Use the [▲] and [▼] keys to select the correct parameter setting. Or, to move to digits within a number, use the keys. The cursor indicates the digit selected to be changed. The [▲] key increases the value, the [▼] key decreases the value.
7. Press the [Cancel] key to disregard the change, or press the [OK] key to accept the change and enter the new setting.

### 7.1.5 Changing a Text Value

If the selected parameter is a text value, it can be changed by using the up/down navigation keys.

The up key increases the value, and the down key decreases the value.

Place the cursor on the value to be saved and press [OK].

7

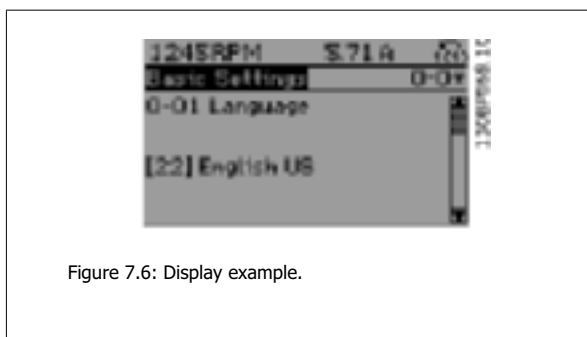


Figure 7.6: Display example.

### 7.1.6 Changing a Group of Numeric Data Values

If the chosen parameter represents a numeric data value, change the chosen data value by means of the [←] and [→] navigation keys as well as the up/down [▲] [▼] navigation keys. Use the [←] and [→] navigation keys to move the cursor horizontally.

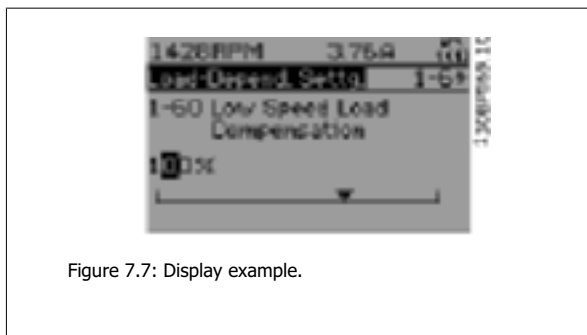


Figure 7.7: Display example.

Use the up/down navigation keys to change the data value. The up key increases the data value, while the down key reduces it. Place the cursor on the value to be saved and press [OK].

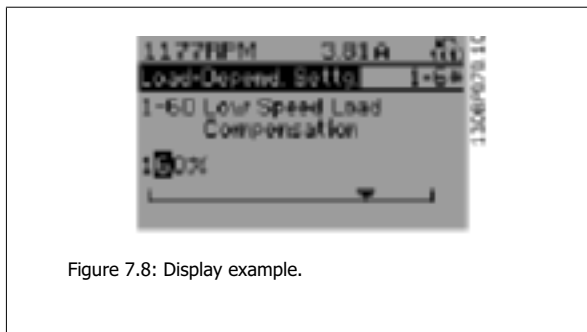


Figure 7.8: Display example.

### 7.1.7 Changing of Data Value, Step-by-Step

Certain parameters can be changed step-by-step or by an infinite number of variables. This applies to par. 1-20 *Motor Power [kW]*, par. 1-22 *Motor Voltage* and par. 1-23 *Motor Frequency*.

The parameters are changed both as a group of numeric data values, and as numeric data values using an infinite number of variables.

### 7.1.8 Readout and Programming of Indexed Parameters

Parameters are indexed when placed in a rolling stack.

Par. 15-30 *Alarm Log: Error Code* to par. 15-32 *Alarm Log: Time* contain a fault log which can be read out. Choose a parameter, press [OK], and use the up/down navigation keys to scroll through the value log.

Use par. 3-10 *Preset Reference* as another example:

Choose the parameter, press [OK], and use the up/down navigation keys to scroll through the indexed values. To change the parameter value, select the indexed value and press [OK]. Change the value by using the up/down keys. Press [OK] to accept the new setting. Press [Cancel] to abort. Press [Back] to leave the parameter.


### 7.1.9 Tips and Tricks

*	For the majority of water and wastewater applications, the Quick Menu, Quick Set-up and Function Set-ups provide the simplest and quickest access to all of the typical parameters required.
*	Whenever possible, performing an AMA will ensure best shaft performance.
*	Display contrast can be adjusted by pressing [Status] and [▲] for a darker display, or by pressing [Status] and [▼] for a brighter display.
*	Under [Quick Menu] and [Changes Made], all the parameters that have been changed from the factory settings are displayed.
*	Press and hold the [Main Menu] key for 3 seconds to access any parameter.
*	For service purposes, it is recommended to copy all parameters to the LCP, see par 0-50 for further information.

Table 7.1: Tips and tricks

### 7.1.10 Quick Transfer of Parameter Settings when Using GLCP

Once the set-up of an adjustable frequency drive is complete, it is recommended to store (backup) the parameter settings in the GLCP or on a PC via MCT 10 Set-up Software Tool.



**NOTE!**  
Stop the motor before performing any of these operations.

**Data storage in LCP:**

1. Go to par. 0-50 *LCP Copy*
2. Press the [OK] key.
3. Select "All to LCP"
4. Press the [OK] key.

All parameter settings are now stored in the GLCP indicated by the progress bar. When 100% is reached, press [OK].

The GLCP can now be connected to another adjustable frequency drive and the parameter settings copied to this adjustable frequency drive.

**Data transfer from LCP to adjustable frequency drive:**

1. Go to par. 0-50 *LCP Copy*
2. Press the [OK] key.
3. Select "All from LCP"
4. Press the [OK] key.

The parameter settings stored in the GLCP are now transferred to the adjustable frequency drive indicated by the progress bar. When 100% is reached, press [OK].

**7.1.11 Initialization to Default Settings**

There are two ways to initialize the adjustable frequency drive to default: Recommended initialization and manual initialization. Please be aware that they have different impacts according to the below description.

**Recommended initialization (via par. 14-22 *Operation Mode*)**

1. Select par. 14-22 *Operation Mode*
2. Press [OK]
3. Select "Initialization" (for NLCP select "2")
4. Press [OK]
5. Disconnect the power from the unit and wait for the display to turn off.
6. Reconnecting the power resets the adjustable frequency drive. Note that first start-up takes a few more seconds
7. Press [Reset]

par. 14-22 *Operation Mode* initializes all except:

- par. 14-50 *RFI 1*
- par. 8-30 *Protocol*
- par. 8-31 *Address*
- par. 8-32 *Baud Rate*
- par. 8-35 *Minimum Response Delay*
- par. 8-36 *Max Response Delay*
- par. 8-37 *Max Inter-Char Delay*
- par. 15-00 *Operating Hours* to par. 15-05 *Over Volts*
- par. 15-20 *Historic Log: Event* to par. 15-22 *Historic Log: Time*
- par. 15-30 *Alarm Log: Error Code* to par. 15-32 *Alarm Log: Time*



**NOTE!**

Parameters selected in par. 0-25 *My Personal Menu* will remain present with the default factory setting.

**Manual initialization**



**NOTE!**

When carrying out manual initialization, serial communication, RFI filter settings and fault log settings are reset. Removes parameters selected in par. 0-25 *My Personal Menu*

1. Disconnect from the line power and wait until the display turns off.
- 2a. Press [Status] - [Main Menu] - [OK] at the same time while powering up the Graphical LCP (GLCP)
- 2b. Press [Menu] while the LCP 101, Numerical Display is powering up.
3. Release the keys after 5 s
4. The adjustable frequency drive is now programmed according to default settings

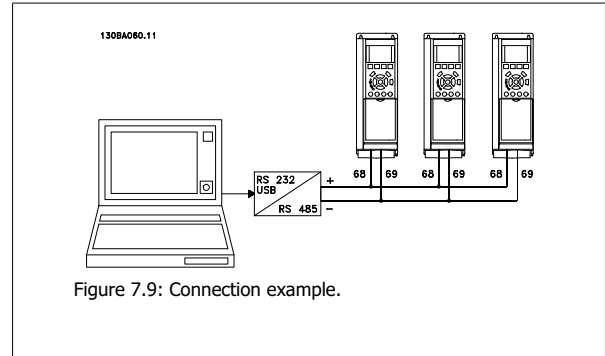
This parameter initializes all except:

- par. 15-00 *Operating Hours*
- par. 15-03 *Power-ups*
- par. 15-04 *Over Temps*
- par. 15-05 *Over Volts*

### 7.1.12 RS-485 Bus Connection

One or more adjustable frequency drives can be connected to a controller (or master) using the standard RS-485 interface. Terminal 68 is connected to the P signal (TX+, RX+), while terminal 69 is connected to the N signal (TX-, RX-).

If more than one adjustable frequency drive is connected to a master, use parallel connections.



In order to avoid potential equalizing currents in the shield, ground the cable screen via terminal 61, which is connected to the frame via an RC link.

#### Bus termination

The RS-485 bus must be terminated by a resistor network at both ends. If the drive is the first or the last device in the RS-485 loop, set the switch S801 on the control card to ON.

For more information, see the paragraph *Switches S201, S202, and S801*.

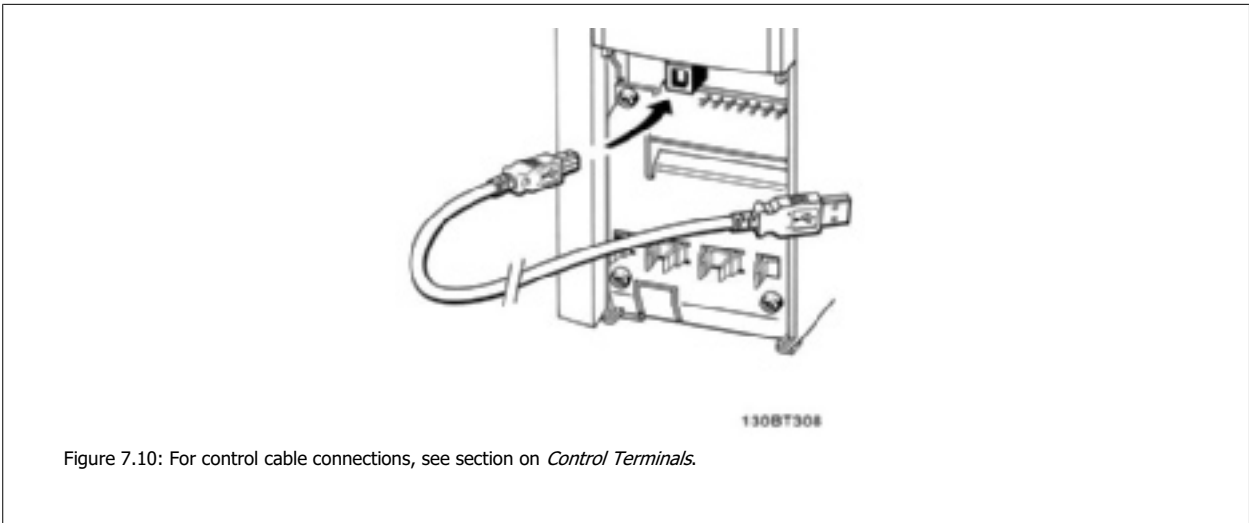


### 7.1.13 How to Connect a PC to the Adjustable Frequency Drive

To control or program the adjustable frequency drive from a PC, install the PC-based Configuration Tool MCT 10.

The PC is connected via a standard (host/device) USB cable, or via the RS-485 interface as shown in the *Design Guide, chapter How to Install > Installation of misc. connections*.

**NOTE!** The USB connection is galvanically isolated from the supply voltage (PELV) and other high-voltage terminals. The USB connection is connected to protection ground on the adjustable frequency drive. Use only isolated laptop for PC connection to the USB connector on the adjustable frequency drive.



## 7.1.14 PC Software Tools

### PC-based Configuration Tool MCT 10

All adjustable frequency drives are equipped with a serial communication port. Danfoss provides a PC tool for communication between PC and adjustable frequency drive, PC-based Configuration Tool MCT 10. Please check the section on *Available Literature* for detailed information on this tool.

### MCT 10 set-up software

MCT 10 has been designed as an easy to use interactive tool for setting parameters in our adjustable frequency drives. The software can be downloaded from the Danfoss internet site <http://www.Danfoss.com/BusinessAreas/DrivesSolutions/SoftwareDownload/DDPC+Software+Program.htm>.

The MCT 10 set-up software will be useful for:

- Planning a communication network off-line. MCT 10 contains a complete adjustable frequency drive database
- Commissioning adjustable frequency drives on-line.
- Saving settings for all adjustable frequency drives.
- Replacing an adjustable frequency drive in a network.
- Simple and accurate documentation of adjustable frequency drive settings after commissioning.
- Expanding an existing network.
- Adjustable frequency drives developed in the future will be fully supported.

# 7

MCT 10 set-up software supports Profibus DP-V1 via a master class 2 connection. This makes it possible to access on-line read/write parameters in an adjustable frequency drive via the Profibus network. This will eliminate the need for an extra communication network.

### Save adjustable frequency drive settings:

1. Connect a PC to the unit via the USB COM port. (Note: Use a PC that is isolated from the line power, in conjunction with the USB port. Failure to do so may damage equipment.)
2. Open MCT 10 Set-up Software
3. Choose "Read from drive"
4. Choose "Save as"

All parameters are now stored on the PC.

### Load adjustable frequency drive settings:


1. Connect a PC to the adjustable frequency drive via the USB com port
2. Open MCT 10 Set-up software
3. Choose "Open"– stored files will be shown.
4. Open the appropriate file
5. Choose "Write to drive"

All parameter settings are now transferred to the adjustable frequency drive.

A separate manual for MCT 10 Set-up Software is available: *MG.10.Rx.yy*.

### The MCT 10 Set-up software modules

The following modules are included in the software package:

	<p><b>MCT Set-up 10 Software</b> Setting parameters Copy to and from adjustable frequency drives Documentation and print-out of parameter settings incl. diagrams</p>
<hr/>	
<p><b>Ext. user interface</b> Preventive Maintenance Schedule Clock settings Timed Action Programming Smart Logic Controller Set-up</p>	

### Ordering number:

Please order the CD containing MCT 10 Set-up software using code number 130B1000.

MCT 10 can also be downloaded from the Danfoss Internet: [WWW.DANFOSS.COM](http://WWW.DANFOSS.COM), *Business Area: Motion Controls.*

7

## 8 How to Program the Adjustable Frequency Drive

### 8.1 How to Program

#### 8.1.1 Parameter Set-up

##### Overview of parameter groups

Group	Title	Function
0-	Operation/Display	Parameters related to the fundamental functions of the adjustable frequency drive, function of the LCP buttons and configuration of the LCP display.
1-	Load/Motor	Parameter group for motor settings.
2-	Brakes	Parameter group for setting brake features in the adjustable frequency drive.
3-	Reference / Ramps	Parameters for reference handling, defining limitations, and configuring the reaction of the adjustable frequency drive to changes.
4-	Limits / Warnings	Parameter group for configuring limits and warnings.
5-	Digital In/Out	Parameter group for configuring the digital inputs and outputs.
6-	Analog In/Out	Parameter group for configuring the analog inputs and outputs.
8-	Communication and Options	Parameter group for configuring communications and options.
9-	Profibus	Parameter group for Profibus-specific parameters.
10-	DeviceNet Serial Communication Bus	Parameter group for DeviceNet-specific parameters.
13-	Smart Logic	Parameter group for Smart Logic Control
14-	Special Functions	Parameter group for configuring special adjustable frequency drive functions.
15-	Drive Information	Parameter group containing adjustable frequency drive information such as operating data, hardware configuration and software versions.
16-	Data Readouts	Parameter group for data readouts, such as current references, voltages, control, alarm, warning and status words.
18-	Info and Readouts	This parameter group contains the last 10 Preventive Maintenance logs.
20-	Drive Closed-loop	This parameter group is used for configuring the closed-loop PID controller that controls the output frequency of the unit.
21-	Extended Closed-loop	Parameters for configuring the three extended closed-loop PID controllers.
22-	Application Functions	These parameters monitor water applications.
23-	Time-based Functions	These parameters are for actions to be performed on a daily or weekly basis, such as different references for working hours/non-working hours.
25-	Basic Cascade Controller Functions	Parameters for configuring the basic cascade controller for sequence control of multiple pumps.
26-	Analog I/O Option MCB 109	Parameters for configuring the Analog I/O Option MCB 109.
27-	Extended Cascade Control	Parameters for configuring the extended cascade control.
29-	Water Application Functions	Parameters for setting water specific functions.
31-	Bypass Option	Parameters for configuring the bypass option

Table 8.1: Parameter Groups

Parameter descriptions and selections are displayed on the Graphic LCP or Numeric LCP in the display area (See Section 5 for details.) Access the parameters by pressing the [Quick Menu] or [Main Menu] key on the control panel. The quick menu is used primarily for commissioning the unit at start-up by providing those parameters necessary to start operation. The main menu provides access to all the parameters for detailed application programming.

All digital input/output and analog input/output terminals are multifunctional. All terminals have factory default functions suitable for the majority of water applications but if other special functions are required, they must be programmed in parameter group 5 or 6.



### 8.1.2 Q1 My Personal Menu

Parameters defined by the user can be stored in Q1 My Personal Menu.

Select *My Personal Menu* to display only the parameters, which have been pre-selected and programmed as personal parameters. For example, a pump or equipment OEM may have pre-programmed these to be in My Personal Menu during factory commissioning to make on-site commissioning / fine tuning simpler. These parameters are selected in par. 0-25 *My Personal Menu*. Up to 20 different parameters can be defined in this menu.

Q1 My Personal Menu	
20-21 Setpoint 1	
20-93 PID Proportional Gain	
20-94 PID Integral Time	

### 8.1.3 Q2 Quick Set-up

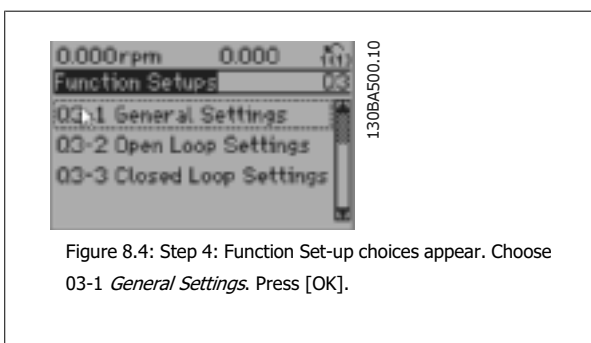
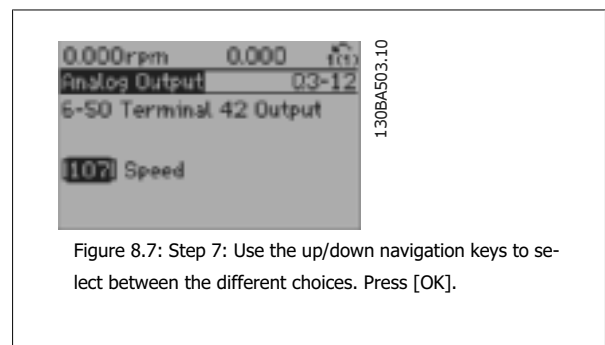
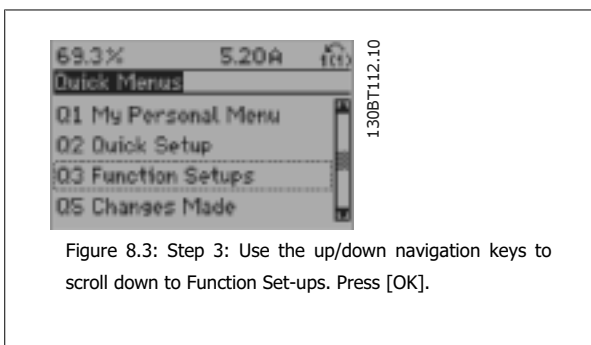
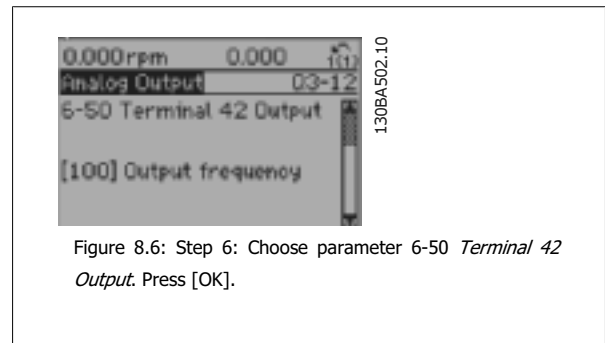
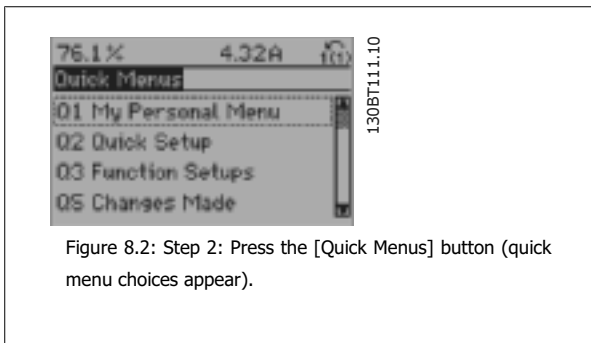
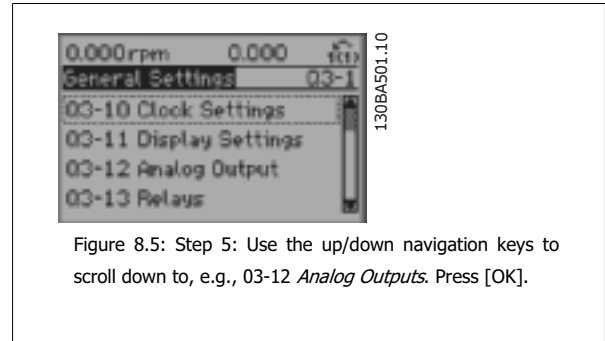
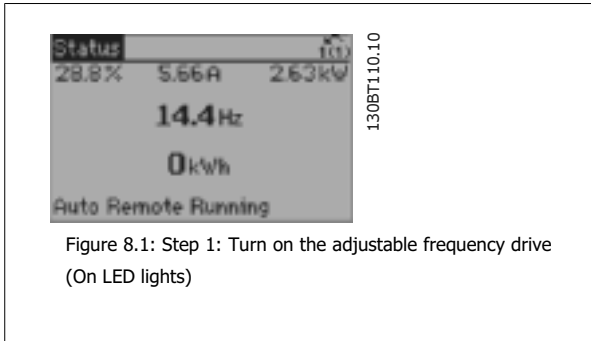
The parameters in Q2 Quick Set-up are the basic parameters which are always needed to set up the adjustable frequency drive for operation.

Parameter number and name	Q2 Quick Set-up Unit
0-01 Language	
1-20 Motor Power	kW
1-22 Motor Voltage	V
1-23 Motor Frequency	Hz
1-24 Motor Current	A
1-25 Motor Nominal Speed	RPM
3-41 Ramp 1 Ramp-up Time	s
3-42 Ramp 1 Ramp-down Time	s
4-11 Motor Speed Low Limit	RPM
4-13 Motor Speed High Limit	RPM
1-29 Automatic Motor Adaptation (AMA)	

### 8.1.4 Q3 Function Set-ups

The function set-up provides quick and easy access to all parameters required for the majority of water and wastewater applications including variable torque, constant torque, pumps, dosing pumps, well pumps, booster pumps, mixer pumps, aeration blowers and other pump and fan applications. Among other features, it also includes parameters for selecting which variables to display on the LCP, digital preset speeds, scaling of analog references, closed-loop single zone and multi-zone applications and specific functions related to water and wastewater applications.

#### How to access the Function Set-up - example:



The Function Set-up parameters are grouped in the following way:

Q3-1 General Settings			
Q3-10 Clock Settings	Q3-11 Display Settings	Q3-12 Analog Output	Q3-13 Relays
0-70 Set Date and Time	0-20 Display Line 1.1 Small	6-50 Terminal 42 Output	Relay 1 ⇒ 5-40 Function Relay
0-71 Date Format	0-21 Display Line 1.2 Small	6-51 Terminal 42 Output Min Scale	Relay 2 ⇒ 5-40 Function Relay
0-72 Time Format	0-22 Display Line 1.3 Small	6-52 Terminal 42 Output Max Scale	Option relay 7 ⇒ 5-40 Function Relay
0-74 DST/Summertime	0-23 Display Line 2 Large		Option relay 8 ⇒ 5-40 Function Relay
0-76 DST/Summertime Start	0-24 Display Line 3 Large		Option relay 9 ⇒ 5-40 Function Relay
0-77 DST/Summertime End	0-37 Display Text 1		
	0-38 Display Text 2		
	0-39 Display Text 3		

Q3-2 Open-loop Settings	
Q3-20 Digital Reference	Q3-21 Analog Reference
3-02 Minimum Reference	3-02 Minimum Reference
3-03 Maximum Reference	3-03 Maximum Reference
3-10 Preset Reference	6-10 Terminal 53 Low Voltage
5-13 Terminal 29 Digital Input	6-11 Terminal 53 High Voltage
5-14 Terminal 32 Digital Input	6-14 Terminal 53 Low Ref/Feedb. Value
5-15 Terminal 33 Digital Input	6-15 Terminal 53 High Ref/Feedb. Value

Q3-3 Closed-loop Settings	
Q3-30 Feedback Settings	Q3-31 PID Settings
1-00 Configuration Mode	20-81 PID Normal/Inverse Control
20-12 Reference/Feedb.Unit	20-82 PID Start Speed [RPM]
3-02 Minimum Reference	20-21 Setpoint 1
3-03 Maximum Reference	20-93 PID Proportional Gain
6-20 Terminal 54 Low Voltage	20-94 PID Integral Time
6-21 Terminal 54 High Voltage	
6-24 Terminal 54 Low Ref/Feedb Value	
6-25 Terminal 54 High Ref/Feedb Value	
6-00 Live Zero Timeout Time	
6-01 Live Zero Timeout Function	

### 8.1.5 Q5 Changes Made

Q5 Changes Made can be used for fault finding.

**Select *Changes made* to get information about:**

- The last 10 changes. Use the up/down navigation keys to scroll between the last 10 changed parameters.
- The changes made since default setting.

Select *Loggings* to get information about the display line readouts. The information is shown in graphs.

Only display parameters selected in par. 0-20 and par. 0-24 can be viewed. It is possible to store up to 120 samples in the memory for later reference.

Please notice that the parameters listed in the below tables for Q5 only serve as examples since they will vary depending on the programming of the particular adjustable frequency drive.

Q5-1 Last 10 Changes
20-94 PID Integral Time
20-93 PID Proportional Gain

Q5-2 Since Factory Setting
20-93 PID Proportional Gain
20-94 PID Integral Time

Q5-3 Input Assignments	
Analog Input 53	
Analog Input 54	

### 8.1.6 Q6 Loggings

Q6 Loggings can be used for fault finding.

Please notice that the parameters listed in the table for Q6 below only serve as examples since they will vary depending on the programming of the particular adjustable frequency drive.

Q6 Loggings	
Reference	
Analog Input 53	
Motor Current	
Frequency	
Feedback	
Energy Log	
Trending Cont Bin	
Trending Timed Bin	
Trending Comparison	

### 8.1.7 Main Menu Mode

Both the GLCP and NLCP provide access to the main menu mode. Select main menu mode by pressing the [Main Menu] key. Figure 6.2 shows the resulting read-out, which appears on the display of the GLCP.

Lines 2 through 5 on the display show a list of parameter groups which can be chosen by toggling the up and down buttons.

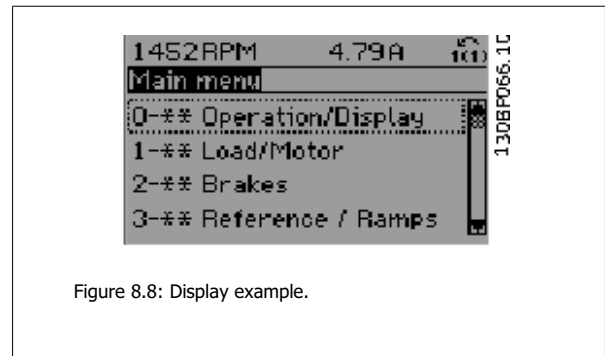


Figure 8.8: Display example.

Each parameter has a name and number which remain the same regardless of the programming mode. In main menu mode, the parameters are divided into groups. The first digit of the parameter number (from the left) indicates the parameter group number.

All parameters can be changed in the main menu. The configuration of the unit (par. 1-00 *Configuration Mode*) will determine other parameters available for programming. For example, selecting Closed-loop enables additional parameters related to closed-loop operation. Option cards added to the unit enable additional parameters associated with the option device.

### 8.1.8 Parameter Selection

In main menu mode, the parameters are divided into groups. Select a parameter group using the navigation keys.

The following parameter groups are accessible:

Group no.	Parameter group:
0	Operation/Display
1	Load/Motor
2	Brakes
3	References/Ramps
4	Limits/Warnings
5	Digital In/Out
6	Analog In/Out
8	Comm. and Options
9	Profibus
10	CAN Ser. Com. Bus
11	LonWorks
13	Smart Logic
14	Special Functions
15	Drive Information
16	Data Readouts
18	Data Readouts 2
20	Drive Closed-loop
21	Ext. Closed-loop
22	Application Functions
23	Time-based Functions
24	Fire Mode
25	Cascade Controller
26	Analog I/O Option MCB 109

Table 8.2: Parameter groups.

# 8

After selecting a parameter group, choose a parameter by means of the navigation keys.

The middle section on the GLCP display shows the parameter number and name, as well as the selected parameter value.

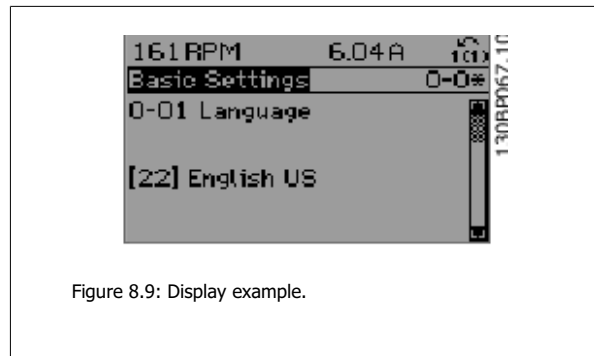


Figure 8.9: Display example.

## 8.2 Commonly Used Parameters - Explanations

### 8.2.1 Main Menu

The main menu includes all available parameters in the VLT® AQUA Drive FC 200 adjustable frequency drive.

All parameters are grouped logically with a group name indicating the function of the parameter group.

All parameters are listed by name and number in the section *Parameter Options* in this Instruction Manual.

All parameters included in the quick menus (Q1, Q2, Q3, Q5 and Q6) can be found in the following.

Some of the most commonly used parameters for VLT® AQUA Drive applications are also explained in the following section.

For a detailed explanation of all parameters, please refer to the VLT® AQUA Drive Programming Guide MG.20.OX.YY which is available at [www.danfoss.com](http://www.danfoss.com) or by ordering it from the local Danfoss office.

## 8.2.2 0-\*\* Operation / Display

Parameters related to the fundamental functions of the adjustable frequency drive, function of the LCP buttons and configuration of the LCP display.

### 0-01 Language

**Option:**

**Function:**

Defines the language to be used in the display.

The adjustable frequency drive can be delivered with 4 different language packages. English and German are included in all packages. English cannot be erased or manipulated.

[0] *	English	Part of Language packages 1 - 4
[1]	German	Part of Language packages 1 - 4
[2]	French	Part of Language package 1
[3]	Danish	Part of Language package 1
[4]	Spanish	Part of Language package 1
[5]	Italian	Part of Language package 1
[6]	Swedish	Part of Language package 1
[7]	Dutch	Part of Language package 1
[10]	Chinese	Language package 2
[20]	Finnish	Part of Language package 1
[22]	English US	Part of Language package 4
[27]	Greek	Part of Language package 4
[28]	Portuguese	Part of Language package 4
[36]	Slovenian	Part of Language package 3
[39]	Korean	Part of Language package 2
[40]	Japanese	Part of Language package 2
[41]	Turkish	Part of Language package 4
[42]	Traditional Chinese	Part of Language package 2
[43]	Bulgarian	Part of Language package 3
[44]	Serbian	Part of Language package 3
[45]	Romanian	Part of Language package 3
[46]	Hungarian	Part of Language package 3
[47]	Czech	Part of Language package 3
[48]	Polish	Part of Language package 4
[49]	Russian	Part of Language package 3
[50]	Thai	Part of Language package 2
[51]	Bahasa Indonesian	Part of Language package 2

### 0-20 Display Line 1.1 Small

**Option:**

**Function:**

Select a variable for display in line 1, left position.

[0]	None	No display value selected
[37]	Display Text 1	Present control word
[38]	Display Text 2	Enables an individual text string to be written, for display in the LCP or to be read via serial communication.
[39]	Display Text 3	Enables an individual text string to be written, for display in the LCP or to be read via serial communication.

[89]	Date and Time Readout	Displays the current date and time.
[953]	Profibus Warning Word	Displays Profibus communication warnings.
[1005]	Readout Transmit Error Counter	View the number of CAN control transmission errors since the last power-up.
[1006]	Readout Receive Error Counter	View the number of CAN control receipt errors since the last power-up.
[1007]	Readout Bus-off Counter	View the number of Bus Off events since the last power-up.
[1013]	Warning Parameter	View a DeviceNet-specific warning word. One separate bit is assigned to every warning.
[1115]	LON Warning Word	Shows the LON-specific warnings.
[1117]	XIF Revision	Shows the version of the external interface file of the Neuron C chip on the LON option.
[1118]	LON Works Revision	Shows the software version of the application program of the Neuron C chip on the LON option.
[1500]	Operating Hours	View the number of running hours of the adjustable frequency drive.
[1501]	Running Hours	View the number of running hours of the motor.
[1502]	kWh Counter	View the line power consumption in kWh.
[1600]	Control Word	View the control word sent from the adjustable frequency drive via the serial communication port in hex code.
[1601] *	Reference [Unit]	Total reference (sum of digital/analog/preset/bus/freeze ref./catch up and slow-down) in selected unit.
[1602]	Reference %	Total reference (sum of digital/analog/preset/bus/freeze ref./catch up and slow-down) in percent.
[1603]	Status Word	Present status word
[1605]	Main Actual Value [%]	One or more warnings in a Hex code
[1609]	Custom Readout	View the user-defined readouts as defined in par. 0-30, 0-31 and 0-32.
[1610]	Power [kW]	Actual power consumed by the motor in kW.
[1611]	Power [hp]	Actual power consumed by the motor in HP.
[1612]	Motor Voltage	Voltage supplied to the motor.
[1613]	Motor Frequency	Motor frequency, i.e., the output frequency of the adjustable frequency drive in Hz.
[1614]	Motor Current	Phase current of the motor measured as effective value.
[1615]	Frequency [%]	Motor frequency, i.e., the output frequency from the adjustable frequency drive in percent.
[1616]	Torque [Nm]	Present motor load as a percentage of the rated motor torque.
[1617]	Speed [RPM]	Speed in RPM (revolutions per minute), i.e., the motor shaft speed in closed-loop based on the entered motor nameplate data, the output frequency and the load on the adjustable frequency drive.
[1618]	Motor Thermal	Thermal load on the motor, calculated by the ETR function. See also parameter group 1-9* Motor Temperature.
[1622]	Torque [%]	Shows the actual torque produced, in percentage.
[1630]	DC Link Voltage	Intermediate circuit voltage in the adjustable frequency drive.
[1632]	BrakeEnergy/s	Present braking energy transferred to an external brake resistor. Stated as an instantaneous value.
[1633]	BrakeEnergy/2 min	Braking energy transferred to an external brake resistor. The mean power is calculated continuously for the most recent 120 seconds.
[1634]	Heatsink Temp.	Present heatsink temperature of the adjustable frequency drive. The cut-out limit is 203° ± 9°F [95° ± 5°C]; cutting back in occurs at 158° ± 9°F [70° ± 5°C].
[1635]	Thermal Drive Load	Percentage load of the inverters
[1636]	Inv. Nom. Current	Nominal current of the adjustable frequency drive
[1637]	Inv. Max. Current	Maximum current of the adjustable frequency drive
[1638]	SL Control State	State of the event executed by the control
[1639]	Control Card Temp.	Temperature of the control card.
[1650]	External Reference	Sum of the external reference as a percentage, i.e., the sum of analog/pulse/bus.

[1652]	Feedback [Unit]	Signal value in units from the programmed digital input(s).
[1653]	DigiPot Reference	View the contribution of the digital potentiometer to the actual reference Feedback.
[1654]	Feedback 1 [Unit]	View the value of Feedback 1. See also par. 20-0*.
[1655]	Feedback 2 [Unit]	View the value of Feedback 2. See also par. 20-0*.
[1656]	Feedback 3 [Unit]	View the value of Feedback 3. See also par. 20-0*.
[1658]	PID Output [%]	Returns the drive closed-loop PID controller output value in percent.
[1659]	Adjusted Setpoint	Displays the actual operating setpoint after it is modified by flow compensation. See parameters 22-8*.
[1660]	Digital Input	Displays the status of the digital inputs. Signal low = 0; Signal high = 1. Regarding order, see par. 16-60. Bit 0 is at the extreme right.
[1661]	Terminal 53 Switch Setting	Setting of input terminal 53. Current = 0; Voltage = 1.
[1662]	Analog Input 53	Actual value at input 53 either as a reference or protection value.
[1663]	Terminal 54 Switch Setting	Setting of input terminal 54. Current = 0; Voltage = 1.
[1664]	Analog Input 54	Actual value at input 54 either as reference or protection value.
[1665]	Analog Output 42 [mA]	Actual value at output 42 in mA. Use par. 6-50 to select the variable to be represented by output 42.
[1666]	Digital Output [bin]	Binary value of all digital outputs.
[1667]	Freq. Input #29 [Hz]	Actual value of the frequency applied at terminal 29 as a pulse input.
[1668]	Freq. Input #33 [Hz]	Actual value of the frequency applied at terminal 33 as a pulse input.
[1669]	Pulse Output #27 [Hz]	Actual value of pulses applied to terminal 27 in digital output mode.
[1670]	Pulse Output #29 [Hz]	Actual value of pulses applied to terminal 29 in digital output mode.
[1671]	Relay Output [bin]	View the setting of all relays.
[1672]	Counter A	View the present value of Counter A.
[1673]	Counter B	View the present value of Counter B.
[1675]	Analog input X30/11	Actual value of the signal on input X30/11 (General Purpose I/O Card. Option)
[1676]	Analog input X30/12	Actual value of the signal on input X30/12 (General Purpose I/O Card. Optional)
[1677]	Analog output X30/8 [mA]	Actual value at output X30/8 (General Purpose I/O Card. Optional) Use Par. 6-60 to select the variable to be shown.
[1680]	Serial com. bus CTW 1	Control word (CTW) received from the bus master.
[1682]	Serial com. bus REF 1	Main reference value sent with control word via the serial communications network, e.g., from the BMS, PLC or other master controller.
[1684]	Comm. Option STW	Extended serial communication option status word.
[1685]	ADF Port CTW 1	Control word (CTW) received from the bus master.
[1686]	AFD Port REF 1	Status word (STW) sent to the bus master.
[1690]	Alarm Word	One or more alarms in a Hex code (used for serial communications)
[1691]	Alarm Word 2	One or more alarms in a Hex code (used for serial communications)
[1692]	Warning Word	One or more warnings in a Hex code (used for serial communications)
[1693]	Warning Word 2	One or more warnings in a Hex code (used for serial communications)
[1694]	Ext. Status Word	One or more status conditions in a Hex code (used for serial communications)
[1695]	Ext. Status Word 2	One or more status conditions in a Hex code (used for serial communications)
[1696]	Maintenance Word	The bits reflect the status for the preventive maintenance events programmed in parameter group 23-1*
[1830]	Analog Input X42/1	Shows the value of the signal applied to terminal X42/1 on the Analog I/O card.
[1831]	Analog Input X42/3	Shows the value of the signal applied to terminal X42/3 on the Analog I/O card.
[1832]	Analog Input X42/5	Shows the value of the signal applied to terminal X42/5 on the Analog I/O card.



[1833]	Analog Out X42/7 [V]	Shows the value of the signal applied to terminal X42/7 on the Analog I/O card.
[1834]	Analog Out X42/9 [V]	Shows the value of the signal applied to terminal X42/9 on the Analog I/O card.
[1835]	Analog Out X42/11 [V]	Shows the value of the signal applied to terminal X42/11 on the Analog I/O card.
[2117]	Ext. 1 Reference [Unit]	The value of the reference for extended Closed-loop Controller 1
[2118]	Ext. 1 Feedback [Unit]	The value of the feedback signal for extended Closed-loop Controller 1
[2119]	Ext. 1 Output [%]	The value of the output from extended Closed-loop Controller 1
[2137]	Ext. 2 Reference [Unit]	The value of the reference for extended Closed-loop Controller 2
[2138]	Ext. 2 Feedback [Unit]	The value of the feedback signal for extended Closed-loop Controller 2
[2139]	Ext. 2 Output [%]	The value of the output from extended Closed-loop Controller 2
[2157]	Ext. 3 Reference [Unit]	The value of the reference for extended Closed-loop Controller 3
[2158]	Ext. 3 Feedback [Unit]	The value of the feedback signal for extended Closed-loop Controller 3
[2159]	Ext. Output [%]	The value of the output from extended Closed-loop Controller 3
[2230]	No-Flow Power	The calculated No-Flow Power for the actual operating speed
[2580]	Cascade Status	Status for the operation of the cascade controller
[2581]	Pump Status	Status for the operation of each individual pump controlled by the cascade controller
[2791]	Cascade Reference	Reference output for use with follower drives.
[2792]	% Of Total Capacity	Readout parameter to show the system operating point as a % capacity of total system capacity.
[2793]	Cascade Option Status	Readout parameter to show the status of the cascade system.

8

**0-21 Display Line 1.2 Small**

<b>Option:</b>	<b>Function:</b>
	Select a variable for display in line 1, middle position.
[1662] * Analog input 53	The options are the same as those listed for par. 0-20 <i>Display Line 1.1 Small</i> .

**0-22 Display Line 1.3 Small**

<b>Option:</b>	<b>Function:</b>
	Select a variable for display in line 1, right position.
[1614] * Motor Current	The options are the same as those listed for par. 0-20 <i>Display Line 1.1 Small</i> .

**0-23 Display Line 2 Large**

<b>Option:</b>	<b>Function:</b>
	Select a variable for display in line 2.
[1615] * Frequency	The options are the same as those listed for par. 0-20 <i>Display Line 1.1 Small</i>

**0-24 Display Line 3 Large**

<b>Option:</b>	<b>Function:</b>
[1652] * Feedback [Unit]	The options are the same as those listed for par. 0-20 <i>Display Line 1.1 Small</i> .
	Select a variable for display in line 2.

### 0-37 Display Text 1

**Range:**

0 N/A\* [0 - 0 N/A]

**Function:**

In this parameter, it is possible to write an individual text string for display in the LCP or to be read via serial communication. If it is to be displayed permanently, select Display Text 1 in par. 0-20 *Display Line 1.1 Small*, par. 0-21 *Display Line 1.2 Small*, par. 0-22 *Display Line 1.3 Small*, par. 0-23 *Display Line 2 Large* or par. 0-24 *Display Line 3 Large*. Use the ▲ or ▼ buttons on the LCP to change a character. Use the ◀ and ▶ buttons to move the cursor. When a character is highlighted by the cursor, it can be changed. Use the ▲ or ▼ buttons on the LCP to change a character. A character can be inserted by placing the cursor between two characters and pressing ▲ or ▼.

### 0-38 Display Text 2

**Range:**

0 N/A\* [0 - 0 N/A]

**Function:**

In this parameter, it is possible to write an individual text string for display in the LCP or to be read via serial communication. If to be displayed permanently select Display Text 2 in par. 0-20 *Display Line 1.1 Small*, par. 0-21 *Display Line 1.2 Small*, par. 0-22 *Display Line 1.3 Small*, par. 0-23 *Display Line 2 Large* or par. 0-24 *Display Line 3 Large*. Use the ▲ or ▼ buttons on the LCP to change a character. Use the ◀ and ▶ buttons to move the cursor. When a character is highlighted by the cursor, this character can be changed. A character can be inserted by placing the cursor between two characters and pressing ▲ or ▼.

### 0-39 Display Text 3

**Range:**

0 N/A\* [0 - 0 N/A]

**Function:**

In this parameter, it is possible to write an individual text string for display in the LCP or to be read via serial communication. If it is to be displayed permanently, select Display Text 3 in par. 0-20 *Display Line 1.1 Small*, par. 0-21 *Display Line 1.2 Small*, par. 0-22 *Display Line 1.3 Small*, par. 0-23 *Display Line 2 Large* or par. 0-24 *Display Line 3 Large*. Use the ▲ or ▼ buttons on the LCP to change a character. Use the ◀ and ▶ buttons to move the cursor. When a character is highlighted by the cursor, this character can be changed. A character can be inserted by placing the cursor between two characters and pressing ▲ or ▼.

### 0-70 Set Date and Time

**Range:**

2000-01-01 [2000-01-01 00:00]  
00:00 –  
2099-12-01  
23:59 \*

**Function:**

Sets the date and time of the internal clock. The format to be used is set in par. 0-71 and 0-72.



**NOTE!**

This parameter does not display the actual time. This can be read in par. 0-89. The clock will not begin counting until a setting different from default has been made.

### 0-71 Date Format

**Option:**

- [0] \* YYYY-MM-DD
- [1] DD-MM-YYYY
- [2] MM/DD/YYYY

**Function:**

- Sets the date format to be used in the LCP.
- Sets the date format to be used in the LCP.
- Sets the date format to be used in the LCP.

**0-72 Time Format**

Option:	Function:
[0] * 24 h	Sets the time format to be used in the LCP.
[1] 12 h	

**0-74 DST/Summertime**

Option:	Function:
[0] * OFF	Choose how Daylight Saving Time/Summertime should be handled. For manual DST/Summertime enter the start date and end date in par. 0-76 <i>DST/Summertime Start</i> and par. 0-77 <i>DST/Summertime End</i> .
[2] Manual	

**0-76 DST/Summertime Start**

Range:	Function:
0 N/A* [0 - 0 N/A]	Sets the date and time when summertime/DST starts. The date is programmed in the format selected in par. 0-71 <i>Date Format</i> .

**0-77 DST/Summertime End**


Range:	Function:
0 N/A* [0 - 0 N/A]	Sets the date and time when summertime/DST ends. The date is programmed in the format selected in par. 0-71 <i>Date Format</i> .

**8.2.3 General Settings, 1-0\***


Define whether the adjustable frequency drive operates in open-loop or closed-loop.

**1-00 Configuration Mode**

Option:	Function:
[0] * Open-loop	Motor speed is determined by applying a speed reference or by setting desired speed when in Hand Mode. Open-loop is also used if the adjustable frequency drive is part of a closed-loop control system based on an external PID controller providing a speed reference signal as output.
[3] Closed-loop	Motor speed will be determined by a reference from the built-in PID controller varying the motor speed as part of a closed-loop control process (e.g., constant pressure or flow). The PID controller must be configured in par. 20-** or via the function set-ups accessed by pressing the [Quick Menu] button.



**NOTE!**  
This parameter cannot be changed when the motor is running.



**NOTE!**  
When set for closed-loop, the commands reversing and start reversing will not reverse the direction of the motor.

### 1-20 Motor Power [kW]

**Range:** **Function:**

4.00 kW\* [0.09 - 3000.00 kW]

### 1-22 Motor Voltage

**Range:** **Function:**

400. V\* [10. - 1000. V]

Enter the nominal motor voltage according to the motor nameplate data. The default value corresponds to the nominal rated output of the unit.  
This parameter cannot be adjusted while the motor is running.

### 1-23 Motor Frequency

**Range:** **Function:**

50. Hz\* [20 - 1000 Hz]

Select the motor frequency value from the motor nameplate data. For 87 Hz operation with 230/400 V motors, set the nameplate data for 230 V/50 Hz. Adapt par. 4-13 *Motor Speed High Limit [RPM]* and par. 3-03 *Maximum Reference* to the 87 Hz application.



**NOTE!**

This parameter cannot be adjusted while the motor is running.

### 1-24 Motor Current

**Range:** **Function:**

7.20 A\* [0.10 - 10000.00 A]

Enter the nominal motor current value from the motor nameplate data. This data is used for calculating motor torque, motor thermal protection, etc.



**NOTE!**

This parameter cannot be adjusted while the motor is running.

### 1-25 Motor Nominal Speed

**Range:** **Function:**

1420. RPM\* [100 - 60000 RPM]

Enter the nominal motor speed value from the motor nameplate data. This data is used for calculating automatic motor compensations.



**NOTE!**

This parameter cannot be changed while the motor is running.

### 1-29 Automatic Motor Adaptation (AMA)

**Option:** **Function:**

The AMA function optimizes dynamic motor performance by automatically optimizing the advanced motor parameters par. 1-30 *Stator Resistance (Rs)* to par. 1-35 *Main Reactance (Xh)* while the motor is stationary.

[0] \* Off


No function

[1]	Enable complete AMA	performs AMA of the stator resistance $R_s$ , the rotor resistance $R_r$ , the stator leakage reactance $X_{1s}$ , the rotor leakage reactance $X_{2r}$ and the main reactance $X_m$ .
[2]	Enable reduced AMA	performs a reduced AMA of the stator resistance $R_s$ in the system only. Select this option if an LC filter is used between the adjustable frequency drive and the motor.


Activate the AMA function by pressing [Hand on] after selecting [1] or [2]. See also the section *Automatic Motor Adaptation*. After a normal sequence, the display will read: "Press [OK] to finish AMA". After pressing the [OK] key, the adjustable frequency drive is ready for operation.

Note:


- For the best adaptation of the adjustable frequency drive, run AMA on a cold motor
- AMA cannot be performed while the motor is running.




**NOTE!**  
It is important to set motor par. 1-2\* Motor Data correctly, since these form part of the AMA algorithm. An AMA must be performed to achieve optimum dynamic motor performance. It may take up to 10 min., depending on the motor power rating.



**NOTE!**  
Avoid generating external torque during AMA



**NOTE!**  
If one of the settings in par. 1-2\* Motor Data is changed, par. 1-30 *Stator Resistance (Rs)* to par. 1-39 *Motor Poles*, the advanced motor parameters, will return to the default setting.  
This parameter cannot be adjusted while the motor is running.



**NOTE!**  
Full AMA should be run without filter only while reduced AMA should be run with filter.


See section: *Application Examples > Automatic Motor Adaptation* in the Design Guide.

### 8.2.4 3-0\* Reference Limits

Parameters for setting the reference unit, limits and ranges.

**3-02 Minimum Reference**

<b>Range:</b>	<b>Function:</b>	
0.000 Ref- [-999999.999 - par. 3-03 ReferenceFeed-ceFeedbackUnit] backUnit*	Enter the Minimum Reference. The Minimum Reference is the lowest value obtainable by adding all references together. The Minimum Reference value and unit matches the configuration choice made in par. 1-00 <i>Configuration Mode</i> and par. 20-12 <i>Reference/Feedback Unit</i> , respectively.	



**NOTE!**  
This parameter is used in open-loop only.

### 3-03 Maximum Reference

**Range:**

50.000 Ref- [par. 3-02 - 999999.999 ReferenceFeed-ceFeedbackUnit] backUnit\*

**Function:**

Enter the maximum acceptable value for the remote reference. The Maximum Reference value and unit matches the configuration choice made in par. 1-00 *Configuration Mode* and par. 20-12 *Reference/Feedback Unit*, respectively.



**NOTE!**

If operating with par. 1-00, Configuration Mode set for Closed-loop [3], par. 20-14, Maximum Reference/Feedb. must be used.

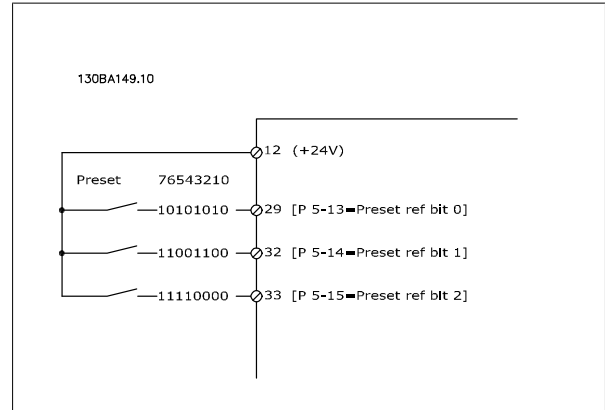
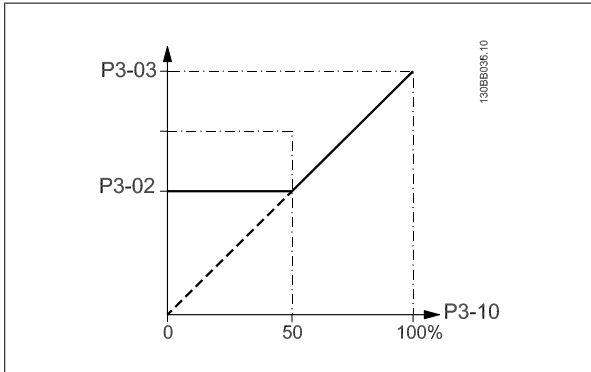
### 3-10 Preset Reference

Array [8]

**Range:**

0.00 %\* [-100.00 - 100.00 %]

**Function:**



### 3-41 Ramp 1 Ramp-up Time

**Range:**

10.00 s\* [1.00 - 3600.00 s]

**Function:**

### 3-42 Ramp 1 Ramp-down Time

**Range:**

20.00 s\* [1.00 - 3600.00 s]

**Function:**

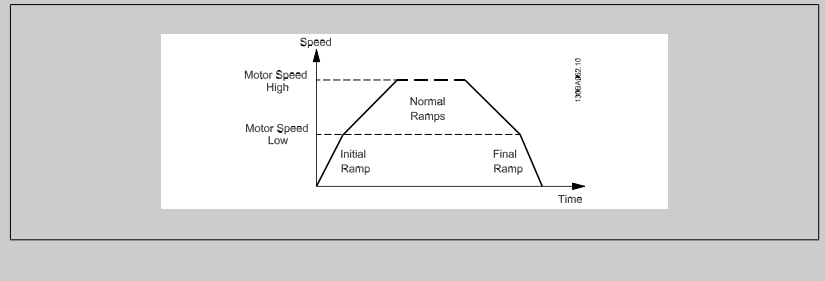
**3-84 Initial Ramp Time**

**Range:**

0 s\* [0–60 s]

**Function:**

Enter the initial ramp-up time from zero speed to Motor Speed Low Limit, par. 4-11 or 4-12. Submersible deep well pumps can be damaged by running below minimum speed. A fast ramp time below minimum pump speed is recommended. This parameter may be applied as a fast ramp rate from zero speed to Motor Speed Low Limit.



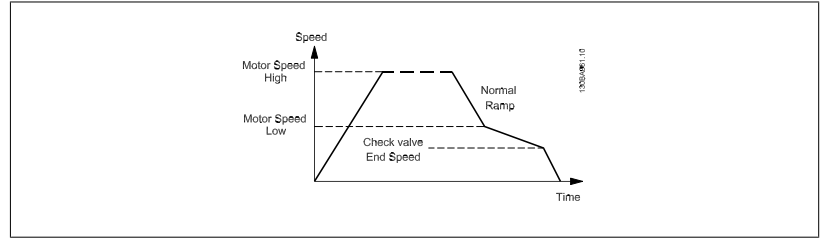
**3-85 Check Valve Ramp Time**

**Range:**

0 s\* [0–60 s]

**Function:**

In order to protect ball check valves in a stop situation, the check valve ramp can be utilized as a slow ramp rate from par. 4-11 *Motor Speed Low Limit [RPM]* or par. 4-12 *Motor Speed Low Limit [Hz]*, to Check Valve Ramp End Speed, set by the user in par. 3-86 or par. 3-87. When par. 3-85 is different from 0 seconds, the Check Valve Ramp Time is effectuated and will be used to ramp down the speed from Motor Speed Low Limit to the Check Valve End Speed in par. 3-86 or par. 3-87.



8

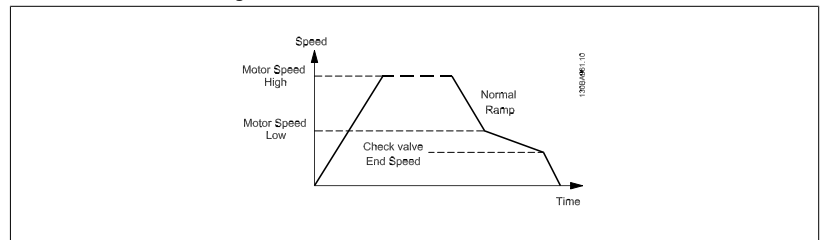
**3-86 Check Valve Ramp End Speed [RPM]**

**Range:**

0 [RPM]\* [0 – Motor Speed Low Limit [RPM]]

**Function:**

Set the speed in [RPM] below Motor Speed Low Limit where the Check Valve is expected to be closed and the Check Valve no longer shall be active.



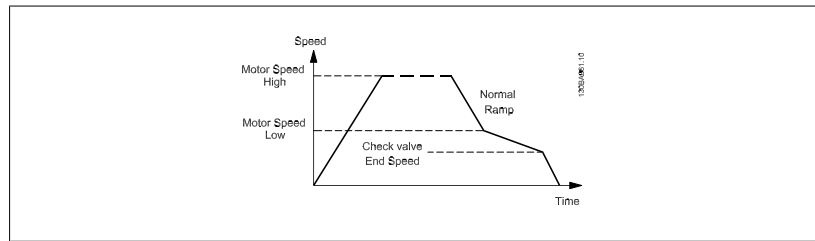
### 3-87 Check Valve Ramp End Speed [Hz]

**Range:**

0 [Hz]\* [0 – Motor Speed Low Limit [Hz]]

**Function:**

Set the speed in [Hz] below Motor Speed Low Limit where the Check Valve Ramp will no longer be active.



### 3-88 Final Ramp Time

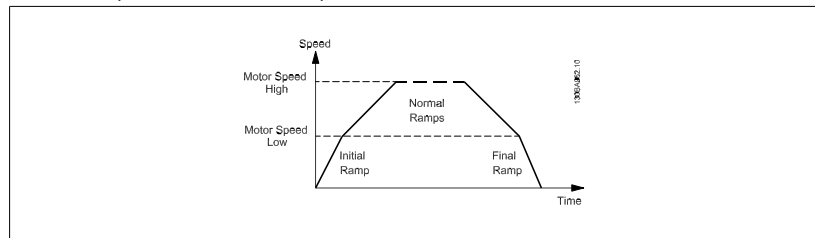
**Range:**

0 [s]\* [0 – 60 [s]]

**Function:**

Enter the Final Ramp Time to be used when ramping down from Motor Speed Low Limit, par. 4-11 or 4-12, to zero speed.

Submersible deep well pumps can be damaged by running below minimum speed. A fast ramp time below minimum pump speed is recommended. This parameter may be applied as a fast ramp rate from Motor Speed Low Limit to zero speed.



## 8.2.5 4-\*\*\* Limits and Warnings

Parameter group for configuring limits and warnings.

### 4-11 Motor Speed Low Limit [RPM]

**Range:**

0 RPM\* [0 - par. 4-13 RPM]

**Function:**

Enter the minimum limit for motor speed. The Motor Speed Low Limit can be set to correspond to the manufacturer’s recommended minimum motor speed. The Motor Speed Low Limit must not exceed the setting in par. 4-13 *Motor Speed High Limit [RPM]*.

### 4-13 Motor Speed High Limit [RPM]


**Range:**

1500. RPM\* [par. 4-11 - 60000. RPM]


**Function:**

Enter the maximum limit for motor speed. The Motor Speed High Limit can be set to correspond to the manufacturer’s maximum rated motor. The Motor Speed High Limit must exceed the setting in par. 4-11 *Motor Speed Low Limit [RPM]*. Only par. 4-11 *Motor Speed Low Limit [RPM]* or par. 4-12 *Motor Speed Low Limit [Hz]* will be displayed, depending on other parameters in the main menu, and depending on default settings dependant on global location.





**NOTE!**  
Max. output frequency cannot exceed 10% of the inverter switching frequency (par. 14-01 *Switching Frequency*).



**NOTE!**  
Any changes in par. 4-13 *Motor Speed High Limit [RPM]* will reset the value in par. 4-53 *Warning Speed High* to the same value as set in par. 4-13 *Motor Speed High Limit [RPM]*.

## 8.2.6 5-\*\* Digital In/Out

Parameter group for configuring the digital input and output.

### 5-01 Terminal 27 Mode

Option:	Function:
[0] * Input	Defines terminal 27 as a digital input.
[1] Output	Defines terminal 27 as a digital output.

Please note that this parameter cannot be adjusted while the motor is running.

# 8

## 8.2.7 5-1\* Digital Inputs

Parameters for configuring the input functions for the input terminals.

The digital inputs are used for selecting various functions in the adjustable frequency drive. All digital inputs can be set to the following functions:

Digital input function	Select	Terminal
No operation	[0]	All *term 32, 33
Reset	[1]	All
Coast inverse	[2]	All
Coast and reset inverse	[3]	All
DC brake inverse	[5]	All
Stop inverse	[6]	All
External interlock	[7]	All
Start	[8]	All *term 18
Latched start	[9]	All
Reversing	[10]	All *term 19
Start reversing	[11]	All
Jog	[14]	All *term 29
Preset reference on	[15]	All
Preset ref bit 0	[16]	All
Preset ref bit 1	[17]	All
Preset ref bit 2	[18]	All
Freeze reference	[19]	All
Freeze output	[20]	All
Speed up	[21]	All
Slow	[22]	All
Set-up select bit 0	[23]	All
Set-up select bit 1	[24]	All
Pulse input	[32]	term 29, 33
Ramp bit 0	[34]	All
Line failure inverse	[36]	All
Run Permissive	[52]	
Hand start	[53]	
Auto-start	[54]	
DigiPot Increase	[55]	All
DigiPot Decrease	[56]	All
DigiPot Clear	[57]	All
Counter A (up)	[60]	29, 33

Counter A (down)	[61]	29, 33
Reset Counter A	[62]	All
Counter B (up)	[63]	29, 33
Counter B (down)	[64]	29, 33
Reset Counter B	[65]	All
Sleep Mode	[66]	
Reset Maintenance Word	[78]	
Lead Pump Start	[120]	
Lead Pump Alternation	[121]	
Pump 1 Interlock	[130]	
Pump 2 Interlock	[131]	
Pump 3 Interlock	[132]	

All = Terminals 18, 19, 27, 29, 32, X30/2, X30/3, X30/4. X30/ are the terminals on MCB 101.

Functions dedicated to only one digital input are stated in the associated parameter.

All digital inputs can be programmed to these functions:


[0]	No operation	No reaction to signals transmitted to terminal.
[1]	Reset	Resets adjustable frequency drive after a TRIP/ALARM. Not all alarms can be reset.
[2]	Coast inverse	Leaves motor in free mode. Logic '0' => coasting stop. (Default Digital input 27): Coasting stop, inverted input (NC).
[3]	Coast and reset inverse	Reset and coasting stop Inverted input (NC). Leaves motor in free mode and resets the adjustable frequency drive. Logic '0' => coasting stop and reset.
[5]	DC brake inverse	Inverted input for DC braking (NC). Stops motor by energizing it with a DC current for a certain time period. See par. 2-01 to par. 2-03. The function is only active when the value in par. 2-02 is different from 0. Logic '0' => DC braking.
[6]	Stop inverse	Stop Inverted function. Generates a stop function when the selected terminal goes from logical level '1' to '0'. The stop is performed according to the selected ramp time (par. 3-42 and par. 3-52).
<div style="display: flex; align-items: center;"> <div> <p><b>NOTE!</b></p> <p>When the adjustable frequency drive is at the torque limit and has received a stop command, it may not stop by itself. To ensure that the adjustable frequency drive stops, configure a digital output to <i>Torque limit &amp; stop</i> [27] and connect this digital output to a digital input that is configured as coast.</p> </div> </div>		
[7]	External Interlock	Same function as Coasting stop, inverse, but External Interlock generates the alarm message 'external fault' on the display when the terminal which is programmed for Coast Inverse is logic '0'. The alarm message will also be active via digital outputs and relay outputs, if programmed for External Interlock. The alarm can be reset using a digital input or the [RESET] key if the cause for the External Interlock has been removed. A delay can be programmed in par. 22-00, External Interlock Time. After applying a signal to the input, the reaction described above will be delayed with the time set in par. 22-00.
[8]	Start	Select start for a start/stop command. Logic '1' = start, logic '0' = stop. (Default Digital input 18)
[9]	Latched start	Motor starts, if a pulse is applied for min. 2 ms. Motor stops when Stop inverse is activated
[10]	Reversing	Changes direction of motor shaft rotation. Select Logic '1' to reverse. The reversing signal only changes the direction of rotation. It does not activate the start function. Select both directions in par. 4-10 <i>Motor Speed Direction</i> . (Default Digital input 19).
[11]	Start reversing	Used for start/stop and for reversing on the same wire. Signals on start are not allowed at the same time.
[14]	Jog	Used for activating jog speed. See par. 3-11.

(Default Digital input 29)

[15]	Preset reference on	Used for shifting between external reference and preset reference. It is assumed that <i>External/preset</i> [1] has been selected in par. 3-04. Logic '0' = external reference active; logic '1' = one of the eight preset references is active.
[16]	Preset ref bit 0	Enables a choice between one of the eight preset references according to the table below.
[17]	Preset ref bit 1	Enables a choice between one of the eight preset references according to the table below.
[18]	Preset ref bit 2	Enables a choice between one of the eight preset references according to the table below.

Preset ref. bit	2	1	0
Preset ref. 0	0	0	0
Preset ref. 1	0	0	1
Preset ref. 2	0	1	0
Preset ref. 3	0	1	1
Preset ref. 4	1	0	0
Preset ref. 5	1	0	1
Preset ref. 6	1	1	0
Preset ref. 7	1	1	1

[19]	Freeze ref	Freezes actual reference. The frozen reference is now the point of enable/condition for Speed up and Slow to be used. If Speed up/down is used, the speed change always follows ramp 2 (par. 3-51 and 3-52) in the range 0 - par. 3-03 <i>Maximum Reference</i> .
[20]	Freeze output	Freezes actual motor frequency (Hz). The frozen motor frequency is now the point of enable/condition for Speed up and Slow to be used. If Speed up/down is used, the speed change always follows ramp 2 (par. 3-51 and 3-52) in the range 0 - par. 1-23 <i>Motor Frequency</i> .



**NOTE!**  
When Freeze output is active, the adjustable frequency drive cannot be stopped via a low 'start [13]' signal. Stop the adjustable frequency drive via a terminal programmed for Coasting inverse [2] or Coast and reset, inverse [3].

[21]	Speed up	For digital control of the up/down speed is desired (motor potentiometer). Activate this function by selecting either Freeze reference or Freeze output. When Speed up is activated for less than 400 msec., the resulting reference will be increased by 0.1%. If Speed up is activated for more than 400 msec., the resulting reference will ramp according to Ramp 1 in par. 3-41.
[22]	Slow	Same as Speed up [21].
[23]	Set-up select bit 0	Selects one of the four set-ups. Set par. 0-10 <i>Active Set-up</i> to Multi Set-up.
[24]	Set-up select bit 1	Same as Set-up select bit 0 [23]. (Default Digital input 32)
[32]	Pulse input	Select Pulse input when using a pulse sequence as either reference or feedback. Scaling is done in par. group 5-5*.
[34]	Ramp bit 0	Select which ramp to use. Logic "0" will select ramp 1 while logic "1" will select ramp 2.
[36]	Line failure inverse	Activates par. 14-10 <i>Line Failure</i> . Line failure inverse is active in the Logic "0" situation.
[52]	Run Permissive	The input terminal, for which the Run permissive has been programmed must be logic "1" before a start command can be accepted. Run permissive has a logic 'AND' function related to the terminal which is programmed for <i>START</i> [8], <i>Jog</i> [14] or <i>Freeze Output</i> [20], which means that in order to start running the motor, both conditions must be fulfilled. If Run Permissive is programmed on multiple terminals, Run permissive needs only be logic '1' on one of the terminals for the function to be carried out. The digital output signal for Run Request ( <i>Start</i> [8], <i>Jog</i> [14] or <i>Freeze output</i> [20]) programmed in par. 5-3* Digital outputs, or par. 5-4* Relays, will not be affected by Run Permissive.
[53]	Hand start	A signal applied will put the adjustable frequency drive into hand mode as if button <i>Hand On</i> on the LCP has been pressed and a normal stop command will be overridden. If disconnecting the signal, the motor will stop. To make any other start commands valid, another digital input must be assigned to Auto-Start and a signal applied to this. The <i>Hand On</i> and <i>Auto On</i> buttons on the LCP has no

		impact. The <i>Off</i> button on the LCP will override <i>Hand Start</i> and <i>Auto-Start</i> . Press either the <i>Hand On</i> or <i>Auto On</i> button to make <i>Hand Start</i> and <i>Auto-Start</i> active again. If no signal on neither <i>Hand Start</i> nor <i>Auto-Start</i> , the motor will stop regardless of any normal <i>Start</i> command applied. If signal applied to both <i>Hand Start</i> and <i>Auto-Start</i> , the function will be <i>Auto-Start</i> . If pressing the <i>Off</i> button on the LCP, the motor will stop regardless of signals on <i>Hand Start</i> and <i>Auto-Start</i> .
[54]	Auto-start	A signal applied will put the adjustable frequency drive into auto mode as if the LCP button <i>Auto On</i> has been pressed. See also <i>Hand Start</i> [53]
[55]	DigiPot Increase	Uses the input as an INCREASE signal to the Digital Potentiometer function described in parameter group 3-9*
[56]	DigiPot Decrease	Uses the input as a DECREASE signal to the Digital Potentiometer function described in parameter group 3-9*
[57]	DigiPot Clear	Uses the input to CLEAR the Digital Potentiometer reference described in parameter group 3-9*
[60]	Counter A (up)	(Terminal 29 or 33 only) Input for increment counting in the SLC counter.
[61]	Counter A (down)	(Terminal 29 or 33 only) Input for decrement counting in the SLC counter.
[62]	Reset Counter A	Input for reset of counter A.
[63]	Counter B (up)	(Terminal 29 and 33 only) Input for increment counting in the SLC counter.
[64]	Counter B (down)	(Terminal 29 and 33 only) Input for decrement counting in the SLC counter.
[65]	Reset Counter B	Input for reset of counter B.
[66]	Sleep Mode	Forces adjustable frequency drive into sleep mode (see par. 22-4*, Sleep Mode). Reacts on the rising edge of signal applied!
[78]	Reset Preventive Maintenance Word	Resets all data in par. 16-96, Preventive Maintenance Word, to 0.

The below setting options are all related to the cascade controller. Wiring diagrams and settings for parameter, see group 25-\*\* for more details.

[120]	Lead Pump Start	Starts/stops the lead pump (controlled by the adjustable frequency drive). A start requires that also a System Start signal has been applied, e.g., to one of the digital inputs set for <i>Start</i> [8]!
[121]	Lead Pump Alternation	Forces alternation of the lead pump in a cascade controller. <i>Lead Pump Alternation</i> , par. 25-50, must be set to either <i>At Command</i> [2] or <i>At Staging or At Command</i> [3]. <i>Alternation Event</i> , par. 25-51, can be set to any of the four options.

[130 - 138] Pump1 Interlock - Pump9 Interlock The function will depend on the setting in par. 25-06, Number of Pumps. If set to *No* [0], then Pump1 refers to the pump controlled by relay RELAY1 etc. If set to *Yes* [1], Pump1 refers to the pump controlled by the adjustable frequency drive only (without any of the built-in relays involved) and Pump2 to the pump controlled by the relay RELAY1. Variable speed pump (lead) cannot be interlocked in the basic cascade controller.  
See below table:

Setting in Par. 5-1*	Setting in Par. 25-06	
	[0] No	[1] Yes
[130] Pump1 Interlock	Controlled by RELAY1 (only if not lead pump)	Adjustable frequency drive controlled (cannot be interlocked)
[131] Pump2 Interlock	Controlled by RELAY2	Controlled by RELAY1
[132] Pump3 Interlock	Controlled by RELAY3	Controlled by RELAY2
[133] Pump4 Interlock	Controlled by RELAY4	Controlled by RELAY3
[134] Pump5 Interlock	Controlled by RELAY5	Controlled by RELAY4
[135] Pump6 Interlock	Controlled by RELAY6	Controlled by RELAY5
[136] Pump7 Interlock	Controlled by RELAY7	Controlled by RELAY6
[137] Pump8 Interlock	Controlled by RELAY8	Controlled by RELAY7
[138] Pump9 Interlock	Controlled by RELAY9	Controlled by RELAY8

**5-13 Terminal 29 Digital Input**

<b>Option:</b>	<b>Function:</b>
[0] * No Operation	Same options and functions as par. 5-1* <i>Digital Inputs</i> .

**5-14 Terminal 32 Digital Input**

Same options and functions as par. 5-1\*, except for *Pulse input*.

<b>Option:</b>	<b>Function:</b>
[0] * No operation	

**5-15 Terminal 33 Digital Input**

Same options and functions as par. 5-1\* Digital Inputs.

<b>Option:</b>	<b>Function:</b>
[0] * No operation	

**5-30 Terminal 27 Digital Output**

<b>Option:</b>	<b>Function:</b>
	Same options and functions as par. 5-3*.

[0] * No operation
--------------------

**5-40 Function Relay**

Array [8]	(Relay 1 [0], Relay 2 [1], Relay 7 [6], Relay 8 [7], Relay 9 [8])
-----------	---

**8**

Select options to define the function of the relays.  
The selection of each mechanical relay is realized in an array parameter.

[0] * No Operation
[1] Control Ready
[2] Drive Ready
[3] Drive Ready/Remote
[4] Stand-by/No Warning
[5] Running
[6] Running/No Warning
[8] Run on Ref./No Warning
[9] Alarm
[10] Alarm or Warning
[11] At Torque Limit
[12] Out of Current Range
[13] Below Current, low
[14] Above Current, high
[15] Out of Speed Range
[16] Below Speed, low
[17] Above Speed, high
[18] Out of Feedb. Range
[19] Below Feedback, low
[20] Above Feedback, high
[21] Thermal Warning

[25]	Reverse
[26]	Bus OK
[27]	Torque Limit & Stop
[28]	Brake, No Warning
[29]	Brake Ready, No Fault
[30]	Brake Fault (IGBT)
[35]	External Interlock
[36]	Control Word Bit 11
[37]	Control Word Bit 12
[40]	Out of Ref. Range
[41]	Below Reference, low
[42]	Above Ref. high
[45]	Bus ctrl
[46]	Bus ctrl, 1 if timeout
[47]	Bus ctrl, 0 if timeout
[60]	Comparator 0
[61]	Comparator 1
[62]	Comparator 2
[63]	Comparator 3
[64]	Comparator 4
[65]	Comparator 5
[70]	Logic Rule 0
[71]	Logic Rule 1
[72]	Logic Rule 2
[73]	Logic Rule 3
[74]	Logic Rule 4
[75]	Logic Rule 5
[80]	SL Digital Output A
[81]	SL Digital Output B
[82]	SL Digital Output C
[83]	SL Digital Output D
[84]	SL Digital Output E
[85]	SL Digital Output F
[160]	No Alarm
[161]	Running Reverse
[165]	Local Ref. Active
[166]	Remote Ref. Active
[167]	Start Cmd. Active
[168]	Drive in Hand Mode
[169]	Drive in Auto Mode
[180]	Clock Fault
[181]	Prev. Maintenance
[190]	No-Flow

[191]	Dry Pump
[192]	End of Curve
[193]	Sleep Mode
[194]	Broken Belt
[195]	Bypass Valve Control
[199]	Pipe Filling
[211]	Cascade Pump1
[212]	Cascade Pump2
[213]	Cascade Pump3
[223]	Alarm, Trip Locked
[224]	Bypass Mode Active

**5-53 Term. 29 High Ref./Feedb. Value**

Range:	Function:
100.000 N/ [-999999.999 - 999999.999 N/A] A*	Enter the high reference value [RPM] for the motor shaft speed and the high feedback value, see also par. 5-58 <i>Term. 33 High Ref./Feedb. Value</i> .

**8.2.8 6-\*\* Analog In/Out**

8

Parameter group for configuring the analog input and output.

**6-00 Live Zero Timeout Time**

Range:	Function:
10 s* [1 - 99 s]	Enter the Live Zero Timeout time period. Live Zero Timeout Time is active for analog inputs, i.e., terminal 53 or terminal 54, used as reference or feedback sources. If the reference signal value associated with the selected current input falls below 50% of the value set in par. 6-10 <i>Terminal 53 Low Voltage</i> , par. 6-12 <i>Terminal 53 Low Current</i> , par. 6-20 <i>Terminal 54 Low Voltage</i> or par. 6-22 <i>Terminal 54 Low Current</i> for a time period longer than the time set in par. 6-00 <i>Live Zero Timeout Time</i> , the function selected in par. 6-01 <i>Live Zero Timeout Function</i> will be activated.

### 6-01 Live Zero Timeout Function

**Option:**

**Function:**

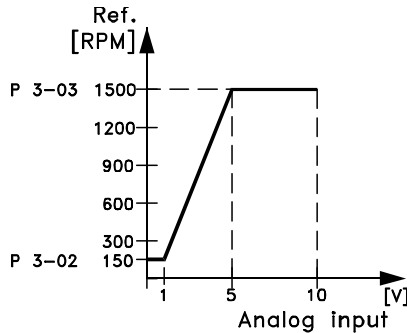
Select the timeout function. The function set in par. 6-01 *Live Zero Timeout Function* will be activated if the input signal on terminal 53 or 54 is below 50% of the value in par. 6-10 *Terminal 53 Low Voltage*, par. 6-12 *Terminal 53 Low Current*, par. 6-20 *Terminal 54 Low Voltage* or par. 6-22 *Terminal 54 Low Current* for a time period defined in par. 6-00 *Live Zero Timeout Time*. If several timeouts occur simultaneously, the adjustable frequency drive prioritizes the timeout functions as follows:

1. par. 6-01 *Live Zero Timeout Function*
2. par. 8-04 *Control Timeout Function*

The output frequency of the adjustable frequency drive can be:

- [1] frozen at the present value
- [2] overruled to stop
- [3] overruled to jog speed
- [4] overruled to max. speed
- [5] overruled to stop with subsequent trip

[0] *	Off
[1]	Freeze output
[2]	Stop
[3]	Jogging
[4]	Max. speed
[5]	Stop and trip



### 6-10 Terminal 53 Low Voltage

**Range:**

0.07 V\* [0.00 - par. 6-11 V]

**Function:**

Enter the low voltage value. This analog input scaling value should correspond to the low reference/feedback value set in par. 6-14 *Terminal 53 Low Ref./Feedb. Value*.

### 6-11 Terminal 53 High Voltage

**Range:**

10.00 V\* [par. 6-10 - 10.00 V]

**Function:**

Enter the high voltage value. This analog input scaling value should correspond to the high reference/feedback value set in par. 6-15 *Terminal 53 High Ref./Feedb. Value*.



**6-14 Terminal 53 Low Ref./Feedb. Value**

Range:	Function:
0.000 N/A* [-999999.999 - 999999.999 N/A]	Enter the analog input scaling value that corresponds to the low voltage/low current set in par. 6-10 <i>Terminal 53 Low Voltage</i> and par. 6-12 <i>Terminal 53 Low Current</i> .

**6-15 Terminal 53 High Ref./Feedb. Value**

Range:	Function:
50.000 N/ A* [-999999.999 - 999999.999 N/A]	Enter the analog input scaling value that corresponds to the high voltage/high current value set in par. 6-11 <i>Terminal 53 High Voltage</i> and par. 6-13 <i>Terminal 53 High Current</i> .

**6-20 Terminal 54 Low Voltage**

Range:	Function:
0.07 V* [0.00 - par. 6-21 V]	Enter the low voltage value. This analog input scaling value should correspond to the low reference/feedback value, set in par. 6-24 <i>Terminal 54 Low Ref./Feedb. Value</i> .

**6-21 Terminal 54 High Voltage**

Range:	Function:
10.00 V* [par. 6-20 - 10.00 V]	Enter the high voltage value. This analog input scaling value should correspond to the high reference/feedback value set in par. 6-25 <i>Terminal 54 High Ref./Feedb. Value</i> .

**6-24 Terminal 54 Low Ref./Feedb. Value**

Range:	Function:
0.000 N/A* [-999999.999 - 999999.999 N/A]	Enter the analog input scaling value that corresponds to the low voltage/low current value set in par. 6-20 <i>Terminal 54 Low Voltage</i> and par. 6-22 <i>Terminal 54 Low Current</i> .

**6-25 Terminal 54 High Ref./Feedb. Value**

Range:	Function:
100.000 N/ A* [-999999.999 - 999999.999 N/A]	Enter the analog input scaling value that corresponds to the high voltage/high current value set in par. 6-21 <i>Terminal 54 High Voltage</i> and par. 6-23 <i>Terminal 54 High Current</i> .

**6-50 Terminal 42 Output**

Option:	Function:
	Select the function of Terminal 42 as an analog current output. A motor current of 20 mA corresponds to $I_{max}$ .
[0] *	No operation
[100]	Output frequency : 0–100 Hz, (0–20 mA)
[101]	Reference : Minimum reference - Maximum reference, (0–20 mA)
[102]	Feedback : -200% to +200% of par. 20-14, (0–20 mA)
[103]	Motor current : 0 - Inverter Max. Current (par. 16-37), (0–20 mA)
[104]	Torque rel to limit : 0 - Torque limit (par. 4-16), (0–20 mA)
[105]	Torq relate to rated : 0 - Motor rated torque, (0–20 mA)
[106]	Power : 0 - Motor rated power, (0–20 mA)
[107] *	Speed : 0 - Speed High Limit (par. 4-13 and par. 4-14), (0–20 mA)
[113]	Ext. Closed-loop 1 : 0–100%, (0–20 mA)

[114]	Ext. Closed-loop 2	: 0–100%, (0–20 mA)
[115]	Ext. Closed-loop 3	: 0–100%, (0–20 mA)
[130]	Output freq. 4-20mA	: 0–100 Hz
[131]	Reference 4-20mA	: Minimum Reference - Maximum Reference
[132]	Feedback 4-20mA	: -200% to +200% of par. 20-14 <i>Maximum Reference/Feedb.</i>
[133]	Motor cur. 4-20mA	: 0 - Inverter Max. Current (par. 16-37 <i>Inv. Max. Current</i> )
[134]	Torq.% lim 4-20 mA	: 0 - Torque limit (par. 4-16)
[135]	Torq.% nom 4-20 mA	: 0 - Motor rated torque
[136]	Power 4-20mA	: 0 - Motor rated power
[137]	Speed 4-20mA	: 0 - Speed High Limit (4-13 and 4-14)
[139]	Bus ctrl.	: 0–100%, (0–20 mA)
[140]	Bus ctrl. 4-20 mA	: 0 - 100%
[141]	Bus ctrl t.o.	: 0–100%, (0–20 mA)
[142]	Bus ctrl 4-20mA t.o.	: 0 - 100%
[143]	Ext. Closed-loop 1 4-20 mA	: 0 - 100%
[144]	Ext. Closed-loop 2 4-20 mA	: 0 - 100%
[145]	Ext. Closed-loop 3 4-20 mA	: 0 - 100%

**NOTE!**

Values for setting the minimum reference are found in open-loop par. 3-02 *Minimum Reference* and for closed-loop par. 20-13 *Minimum Reference/Feedb.* - values for maximum reference for open-loop are found in par. 3-03 *Maximum Reference* and for closed-loop par. 20-14 *Maximum Reference/Feedb.*.

**6-51 Terminal 42 Output Min Scale**

**Range:**

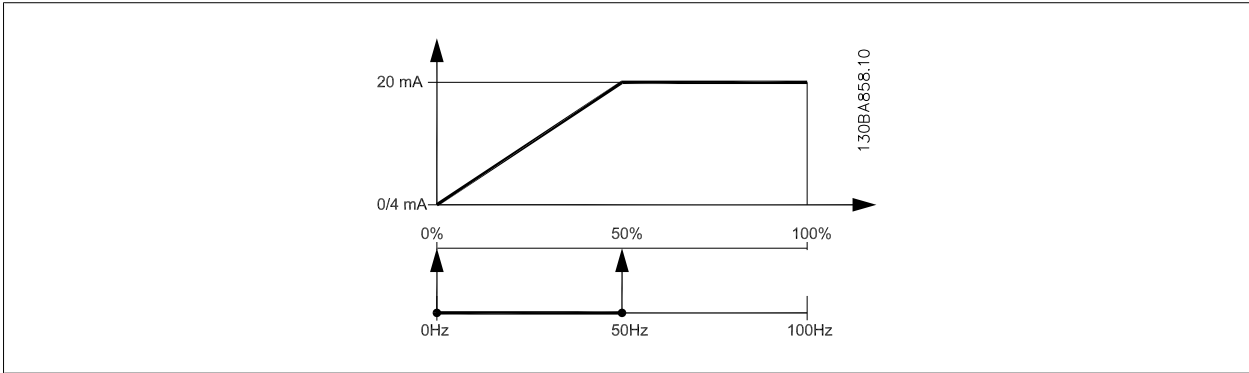
**Function:**

0.00 %\* [0.00 - 200.00 %]

**6-52 Terminal 42 Output Max Scale**

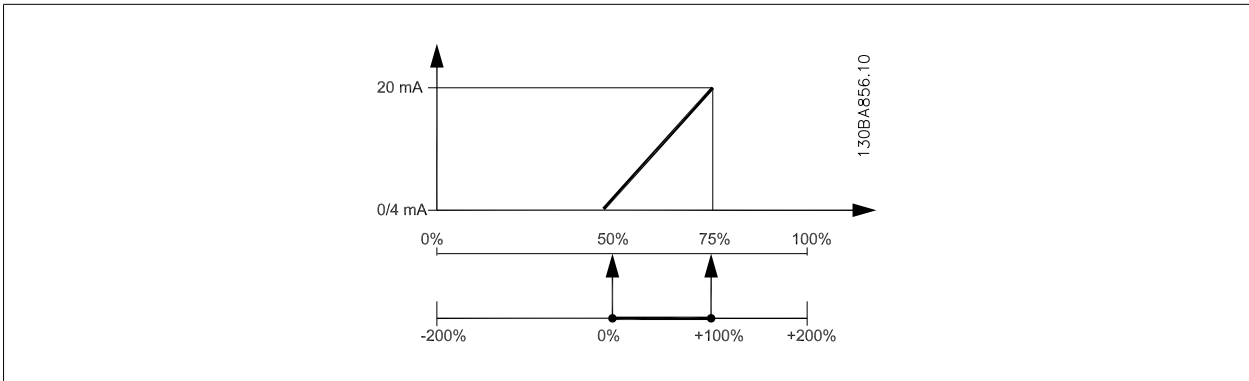
Range:	Function:
100.00 %* [0.00 - 200.00 %]	

EXAMPLE 1:  
 Variable value= OUTPUT FREQUENCY, range = 0–100 Hz  
 Range needed for output = 0–50 Hz  
 Output signal 0 or 4 mA is needed at 0 Hz (0% of range) - set par. 6-51 *Terminal 42 Output Min Scale* to 0%  
 Output signal 20 mA is needed at 50 Hz (50% of range) - set par. 6-52 *Terminal 42 Output Max Scale* to 50%



**8**

EXAMPLE 2:  
 Variable= FEEDBACK, range= -200% to +200%  
 Range needed for output= 0–100%  
 Output signal 0 or 4 mA is needed at 0% (50% of range) - set par. 6-51 *Terminal 42 Output Min Scale* to 50%  
 Output signal 20 mA is needed at 100% (75% of range) - set par. 6-52 *Terminal 42 Output Max Scale* to 75%



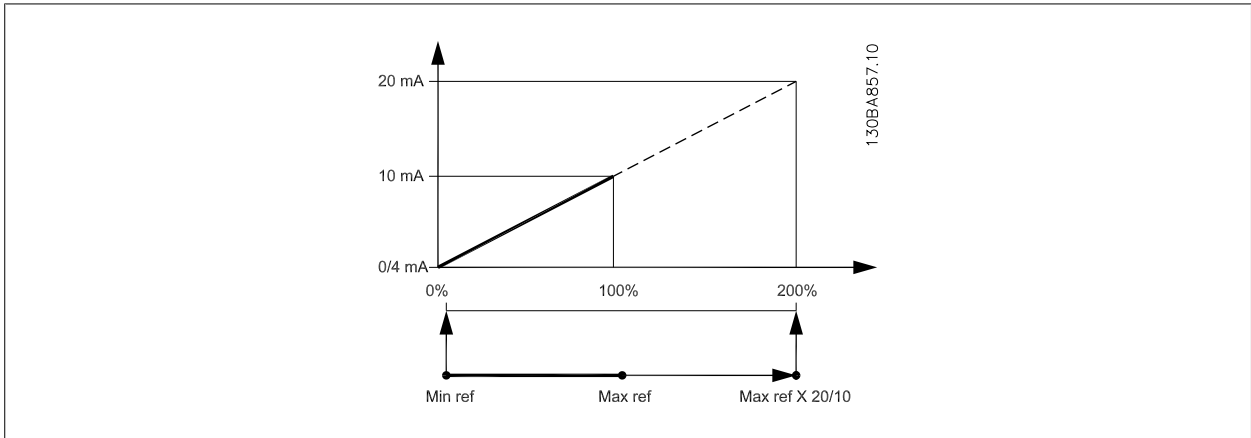
EXAMPLE 3:

Variable value= REFERENCE, range= Min ref - Max ref

Range needed for output= Min ref (0%) - Max ref (100%), 0–10 mA

Output signal 0 or 4 mA is needed at Min ref - set par. 6-51 *Terminal 42 Output Min Scale* to 0%

Output signal 10 mA is needed at Max ref (100% of range) - set par. 6-52 *Terminal 42 Output Max Scale* to 200%  
(20 mA / 10 mA x 100%=200%).



### 8.2.9 Drive Closed-loop, 20-\*\*

This parameter group is used for configuring the closed-loop PID controller, which controls the output frequency of the adjustable frequency drive.

#### 20-12 Reference/Feedback Unit

**Option:**

**Function:**

[0] None

[1] \* %

[5] PPM

[10] 1/min

[11] RPM

[12] Pulse/s

[20] l/s

[21] l/min

[22] l/h

[23] m³/s

[24] m³/min

[25] m³/h

[30] kg/s

[31] kg/min

[32] kg/h

[33] t/min

[34] t/h


[40] m/s

[41] m/min

[45] m

[60]	°C	
[70]	mbar	
[71]	bar	
[72]	Pa	
[73]	kPa	
[74]	m WG	
[75]	mm Hg	
[80]	kW	
[120]	GPM	
[121]	gal/s	
[122]	gal/min	
[123]	gal/h	
[124]	CFM	
[125]	ft³/s	
[126]	ft³/min	
[127]	ft³/h	
[130]	lb/s	
[131]	lb/min	
[132]	lb/h	
[140]	ft/s	
[141]	ft/min	
[145]	ft	
[160]	°F	
[170]	psi	
[171]	lb/in²	
[172]	in WG	
[173]	ft WG	
[174]	in Hg	
[180]	HP	This parameter determines the unit that is used for the setpoint reference and feedback that the PID controller will use for controlling the output frequency of the adjustable frequency drive.

**20-21 Setpoint 1**

<b>Range:</b>	<b>Function:</b>
0.000 Proc-essCtrlUnit* [-999999.999 - 999999.999 Proc-essCtrlUnit]	Setpoint 1 is used in closed-loop mode to enter a setpoint reference that is used by the adjustable frequency drive's PID controller. See the description of par. 20-20 <i>Feedback Function</i> .
	<div style="border: 1px solid black; padding: 5px;">  <p><b>NOTE!</b> Setpoint reference entered here is added to any other references that are enabled (see par. group 3-1*).</p> </div>

### 20-81 PID Normal/Inverse Control

**Option:**

[0] \* Normal

[1] Inverse

**Function:**

*Normal*[0] causes the adjustable frequency drive's output frequency to decrease when the feedback is greater than the setpoint reference. This is common for pressure-controlled supply fan and pump applications.

*Inverse*[1] causes the adjustable frequency drive's output frequency to increase when the feedback is greater than the setpoint reference.

### 20-82 PID Start Speed [RPM]

**Range:**

0 RPM\* [0 - par. 4-13 RPM]

**Function:**

When the adjustable frequency drive is first started, it initially ramps up to this output speed in open-loop mode, following the active ramp-up time. When the output speed programmed here is reached, the adjustable frequency drive will automatically switch to closed-loop mode and the PID controller will begin to function. This is useful in applications in which the driven load must first quickly accelerate to a minimum speed when it is started.



**NOTE!**

This parameter will only be visible if par. 0-02 *Motor Speed Unit* is set to [0], RPM.

### 20-93 PID Proportional Gain

**Range:**

0.50 N/A\* [0.00 - 10.00 N/A]

**Function:**

If (Error x Gain) jumps with a value equal to what is set in par. 20-14 *Maximum Reference/Feedb.*, the PID controller will try to change the output speed equal to what is set in par. 4-13 *Motor Speed High Limit [RPM]*/par. 4-14 *Motor Speed High Limit [Hz]* but in practice of course limited by this setting. The proportional band (error causing output to change from 0–100%) can be calculated by means of the formula:

$$\left( \frac{1}{\text{Proportional Gain}} \right) \times (\text{Max Reference})$$

**NOTE!**

Always set the desired for par. 20-14 *Maximum Reference/Feedb.* before setting the values for the PID controller in par. group 20-9\*.

### 20-94 PID Integral Time

**Range:**

20.00 s\* [0.01 - 10000.00 s]

**Function:**

Over time, the integrator accumulates a contribution to the output from the PID controller as long as there is a deviation between the reference/setpoint and feedback signals. The contribution is proportional to the size of the deviation. This ensures that the deviation (error) approaches zero.

Quick response on any deviation is obtained when the integral time is set to a low value. Setting it too low, however, may cause the control to become unstable.

The value set is the time needed for the integrator to add the same contribution as the proportional part for a certain deviation.

If the value is set to 10,000, the controller will act as a pure proportional controller with a P-band based on the value set in par. 20-93 *PID Proportional Gain*. When no deviation is present, the output from the proportional controller will be 0.


### 8.2.10 22-\*\* Miscellaneous

This group contains parameters used for monitoring water/wastewater applications.


#### 22-20 Low Power Auto Set-up

Option:	Function:
[0] * OFF	When set for <i>Enabled</i> , an auto set-up sequence is activated, automatically setting speed to approx. 50% and 85% of rated motor speed (par. 4-13 <i>Motor Speed High Limit [RPM]</i> , par. 4-14 <i>Motor Speed High Limit [Hz]</i> ). At those two speeds, the power consumption is automatically measured and stored.
[1] Enabled	<p>Before enabling Auto Set-up:</p> <ol style="list-style-type: none"> <li>1. Close valve(s) in order to create a no-flow condition</li> <li>2. The adjustable frequency drive must be set for open-loop (par. 1-00 <i>Configuration Mode</i>).</li> </ol> <p>Note that it is important also to set par. 1-03 <i>Torque Characteristics</i>.</p>


- [0] \* OFF
- [1] Enabled



**NOTE!**  
Auto set-up must be done when the system has reached normal operating temperature!



**NOTE!**  
It is important that the par. 4-13 *Motor Speed High Limit [RPM]* or par. 4-14 *Motor Speed High Limit [Hz]* is set to the max. operational speed of the motor!  
It is important to do the auto set-up before configuring the integrated PI controller as settings will be reset when changing from closed to open-loop in par. 1-00 *Configuration Mode*.



**NOTE!**  
Carry out the tuning with the same settings in par. 1-03 *Torque Characteristics*, as for operation after the tuning.

#### 22-21 Low Power Detection

Option:	Function:
[0] * Disabled	
[1] Enabled	If selecting Enabled, the low power detection commissioning must be carried out in order to set the parameters in group 22-3* for proper operation!

#### 22-22 Low Speed Detection

Option:	Function:
[0] * Disabled	
[1] Enabled	Select Enabled for detecting when the motor operates with a speed as set in par. 4-11 <i>Motor Speed Low Limit [RPM]</i> or par. 4-12 <i>Motor Speed Low Limit [Hz]</i> .

### 22-23 No-Flow Function

**Option:**

**Function:**

Common actions for Low Power Detection and Low Speed Detection (Individual selections not possible).

[0] \* OFF

[1] Sleep Mode

[2] Warning

Messages in the Local Control Panel display (if mounted) and/or signal via a relay or a digital output.

[3] Alarm

The adjustable frequency drive trips and the motor stays stopped until reset.

### 22-24 No-Flow Delay

**Range:**

**Function:**

10 s\* [1 - 600 s]

Set the time. Low Power/Low Speed must remain detected to activate signal for actions. If detection disappears before the timer runs out, the timer will be reset.

### 22-26 Dry Pump Function

**Option:**

**Function:**

*Low Power Detection* must be Enabled (par. 22-21 *Low Power Detection*) and commissioned (using either parameter group 22-3\*, *No Flow Power Tuning*, or par. 22-20 *Low Power Auto Set-up*) in order to use Dry Pump Detection.

[0] \* OFF

[1] Warning

Messages in the Local Control Panel display (if mounted) and/or signal via a relay or a digital output.

[2] Alarm

The adjustable frequency drive trips and the motor stays stopped until reset.

### 22-27 Dry Pump Delay

**Range:**

**Function:**

10 s\* [0 - 600 s]

Defines for how long the Dry Pump condition must be active before activating Warning or Alarm

### 22-30 No-Flow Power

**Range:**

**Function:**

0.00 kW\* [0.00 - 0.00 kW]

Readout of calculated no-flow power at actual speed. If power drops to the display value, the adjustable frequency drive will consider the condition as a no-flow situation.

### 22-31 Power Correction Factor

**Range:**

**Function:**

100 %\* [1 - 400 %]

Make corrections to the calculated power at par. 22-30 *No-Flow Power*.  
If No Flow is detected when it should not be detected, the setting should be decreased. However, if No Flow is not detected when it should be detected, the setting should be increased to above 100%.

### 22-32 Low Speed [RPM]

**Range:**

**Function:**

0 RPM\* [0 - par. 22-36 RPM]

To be used if par. 0-02 *Motor Speed Unit* has been set for RPM (parameter not visible if Hz selected). Set used speed to the 50% level.  
This function is used for storing values needed to tune No-flow Detection.



**22-33 Low Speed [Hz]**

Range:	Function:
0 Hz* [0.0 - par. 22-37 Hz]	To be used if par. 0-02 <i>Motor Speed Unit</i> has been set for Hz (parameter not visible if RPM selected). Set used speed to the 50% level. The function is used for storing values needed to tune No-flow Detection.

**22-34 Low Speed Power [kW]**

Range:	Function:
0 kW* [0.00 - 0.00 kW]	To be used if par. 0-03 <i>Regional Settings</i> has been set for International (parameter not visible if North America selected). Set power consumption to 50% speed level. This function is used for storing values needed to tune No-flow Detection.

**22-35 Low Speed Power [HP]**

Range:	Function:
0 hp* [0.00 - 0.00 hp]	To be used if par. 0-03 <i>Regional Settings</i> has been set for North America (parameter not visible if International selected). Set power consumption to 50% speed level. This function is used for storing values needed to tune No-flow Detection.

**22-36 High Speed [RPM]**

Range:	Function:
0 RPM* [0 - par. 4-13 RPM]	To be used if par. 0-02 <i>Motor Speed Unit</i> has been set for RPM (parameter not visible if Hz selected). Set used speed for the 85% level. The function is used for storing values needed to tune No-flow Detection.

**22-37 High Speed [Hz]**

Range:	Function:
0.0 Hz* [0.0 - par. 4-14 Hz]	To be used if par. 0-02 <i>Motor Speed Unit</i> has been set for Hz (parameter not visible if RPM selected). Set used speed for the 85% level. The function is used for storing values needed to tune No-flow Detection.

**22-38 High Speed Power [kW]**

Range:	Function:
0 kW* [0.00 - 0.00 kW]	To be used if par. 0-03 <i>Regional Settings</i> has been set for International (parameter not visible if North America selected). Set power consumption to 85% speed level. This function is used for storing values needed to tune No-flow Detection.

**22-39 High Speed Power [HP]**

Range:	Function:
0 hp* [0.00 - 0.00 hp]	To be used if par. 0-03 <i>Regional Settings</i> has been set for North America (parameter not visible if International selected). Set power consumption to 85% speed level. This function is used for storing values needed to tune No-flow Detection.

**22-40 Minimum Run Time**

Range:	Function:
10 s* [0 - 600 s]	Set the desired minimum running time for the motor after a start command (digital input or bus) before entering sleep mode.

### 22-41 Minimum Sleep Time

**Range:**

10 s\* [0 - 600 s]

**Function:**

Set the desired minimum time for staying in sleep mode. This will override any wake-up conditions.

### 22-42 Wake-up Speed [RPM]

**Range:**

0 RPM\* [par. 4-11 - par. 4-13 RPM]

**Function:**

To be used if par. 0-02 *Motor Speed Unit* has been set for RPM (parameter not visible if Hz selected). Only to be used if par. 1-00 *Configuration Mode* is set for open-loop and speed reference is applied by an external controller.

Set the reference speed at which sleep mode should be canceled.

### 22-43 Wake-up Speed [Hz]

**Range:**

0 Hz\* [par. 4-12 - par. 4-14 Hz]

**Function:**

To be used if par. 0-02 *Motor Speed Unit* has been set for Hz (parameter not visible if RPM selected). Only to be used if par. 1-00 *Configuration Mode* is set for open-loop and speed reference is applied by an external controller controlling the pressure.

Set the reference speed at which sleep mode should be cancelled.

### 22-44 Wake-up Ref./FB Difference

**Range:**

10%\* [0-100%]

**Function:**

Only to be used if par. 1-00, *Configuration Mode*, is set for closed-loop and the integrated PI controller is used for controlling the pressure.

Set the pressure drop allowed as a percentage of the setpoint for the pressure (Pset) before canceling sleep mode.



**NOTE!**

If used in application where the integrated PI controller is set for inverse control in par. 20-71, *PID, Normal/Inverse Control*, the value set in par. 22-44 will automatically be added.

### 22-45 Setpoint Boost

**Range:**

0 %\* [-100 - 100 %]

**Function:**

Only to be used if par. 1-00 *Configuration Mode*, is set for closed-loop and the integrated PI controller is used. For example, in systems with constant pressure control, it is advantageous to increase the system pressure before the motor is stopped. This will extend the time during which the motor is stopped and help to avoid frequent start/stop.

Set the desired overpressure/temperature as a percentage of the setpoint for the pressure (Pset)/temperature before entering sleep mode.

If set at 5%, the boost pressure will be Pset\*1.05. The negative values can be used, for example, for cooling tower control, where a negative change is needed.

### 22-46 Maximum Boost Time

**Range:**

60 s\* [0 - 600 s]

**Function:**

Only to be used if par. 1-00 *Configuration Mode* is set for closed-loop and the integrated PI controller is used for controlling the pressure.

Set the maximum time for which boost mode will be allowed. If the set time is exceeded, sleep mode will be entered and will not wait for the set boost pressure to be reached.

**22-50 End of Curve Function**

Option:	Function:
[0] * OFF	End of Curve monitoring not active.
[1] Warning	A warning is issued in the display [W94].
[2] Alarm	An alarm is issued and the adjustable frequency drive trips. A message [A94] appears in the display.



**NOTE!**  
Automatic restart will reset the alarm and start the system again.

**22-51 End of Curve Delay**

Range:	Function:
10 s* [0 - 600 s]	When an end of curve condition is detected, a timer is activated. When the time set in this parameter expires and the End of Curve condition has been steady in the entire period, the function set in par. 22-50 <i>End of Curve Function</i> will be activated. If the condition disappears before the timer expires, the timer will be reset.

**22-80 Flow Compensation**

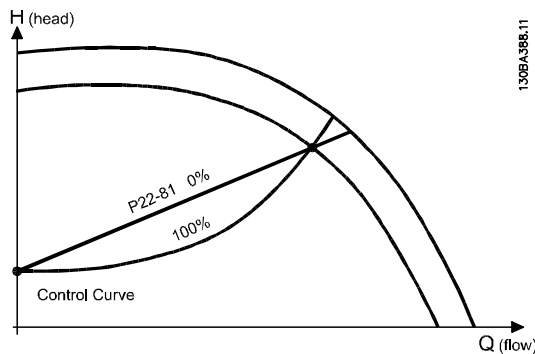
Option:	Function:
[0] * Disabled	[0] <i>Disabled:</i> Setpoint compensation not active.
[1] Enabled	[1] <i>Enabled:</i> Setpoint compensation is active. Enabling this parameter allows the Flow Compensated Setpoint operation.

**22-81 Square-linear Curve Approximation**

Range:	Function:
100 %* [0 - 100 %]	<p><b>Example 1:</b> Adjustment of this parameter allows the shape of the control curve to be adjusted. 0 = Linear 100% = Ideal shape (theoretical).</p>



**NOTE!**  
Please note: Not visible when running in cascade.

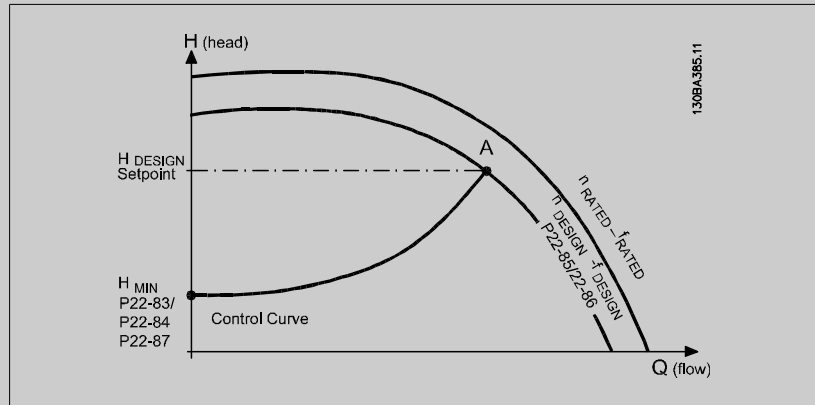


**22-82 Work Point Calculation**

**Option:**

**Function:**

**Example 1:** Speed at System Design Working Point is known:

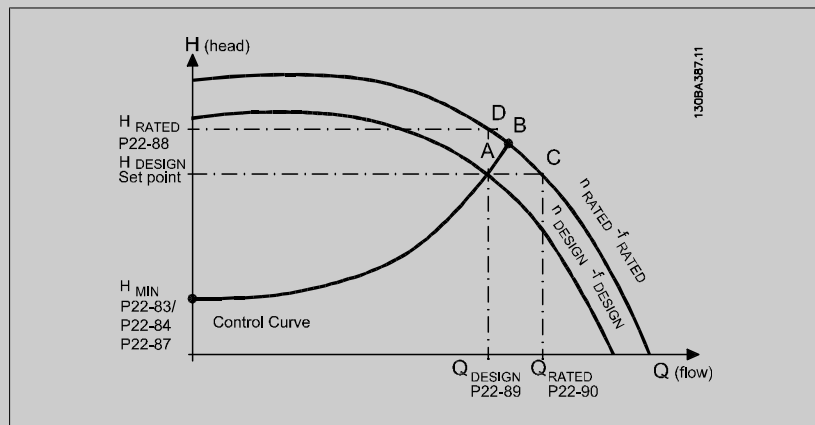


From the data sheet showing characteristics for the specific equipment at different speeds, simply reading across from the  $H_{DESIGN}$  point and the  $Q_{DESIGN}$  point allows us to find point A, which is the system design working point. The pump characteristics at this point should be identified and the associated speed programmed. Closing the valves and adjusting the speed until  $H_{MIN}$  has been achieved allows the speed at the no flow point to be identified.

Adjustment of par. 22-81 *Square-linear Curve Approximation* then allows the shape of the control curve to be adjusted infinitely.

**Example 2:**

Speed at System Design Working Point is not known: Where the Speed at System Design Working Point is unknown, another reference point on the control curve needs to be determined by means of the data sheet. By looking at the curve for the rated speed and plotting the design pressure ( $H_{DESIGN}$ , Point C), the flow at that pressure  $Q_{RATED}$  can be determined. Similarly, by plotting the design flow ( $Q_{DESIGN}$ , Point D), the pressure  $H_D$  at that flow can be determined. Knowing these two points on the pump curve, along with  $H_{MIN}$  described above, allows the adjustable frequency drive to calculate the reference point B and thus to plot the control curve that will also include the system design working point A.



[0] \* Disabled

*Disabled [0]:* Work Point Calculation not active. To be used if speed at design point is known (see table above).

[1] Enabled

*Enabled [1]:* Work Point Calculation is active. Enabling this parameter allows the calculation of the unknown System Design Working Point at 50/60 Hz speed, from the input data set in

par. 22-83 *Speed at No-Flow [RPM]* par. 22-84 *Speed at No-Flow [Hz]*, par. 22-87 *Pressure at No-Flow Speed*, par. 22-88 *Pressure at Rated Speed*, par. 22-89 *Flow at Design Point* and par. 22-90 *Flow at Rated Speed*.

### 22-83 Speed at No-Flow [RPM]

**Range:**

300. RPM\* [0 - par. 22-85 RPM]

**Function:**

Resolution 1 RPM.

The speed of the motor at which the flow is zero and the minimum pressure  $H_{MIN}$  is achieved should be entered here in RPM. Alternatively, the speed in Hz can be entered in par. 22-84 *Speed at No-Flow [Hz]*. If it has been decided to use RPM in par. 0-02 *Motor Speed Unit*, then par. 22-85 *Speed at Design Point [RPM]* should also be used. Closing the valves and reducing the speed until minimum pressure  $H_{MIN}$  is achieved will determine this value.

### 22-84 Speed at No-Flow [Hz]

**Range:**

50.0 Hz\* [0.0 - par. 22-86 Hz]

**Function:**

Resolution 0.033 Hz.

The speed of the motor at which flow has effectively stopped and minimum pressure  $H_{MIN}$  is achieved should be entered here in Hz. Alternatively, the speed in RPM can be entered in par. 22-83 *Speed at No-Flow [RPM]*. If it has been decided to use Hz in par. 0-02 *Motor Speed Unit*, then par. 22-86 *Speed at Design Point [Hz]* should also be used. Closing the valves and reducing the speed until minimum pressure  $H_{MIN}$  is achieved will determine this value.

8

### 22-85 Speed at Design Point [RPM]

**Range:**

1500. RPM\* [par. 22-83 - 60000. RPM]

**Function:**

Resolution 1 RPM.

Only visible when par. 22-82 *Work Point Calculation* is set to *Disable*. The speed of the motor at which the system design working point is achieved should be entered here in RPM. Alternatively, the speed in Hz can be entered in par. 22-86 *Speed at Design Point [Hz]*. If it has been decided to use RPM in par. 0-02 *Motor Speed Unit*, then par. 22-83 *Speed at No-Flow [RPM]* should also be used.

### 22-86 Speed at Design Point [Hz]

**Range:**

50/60.0 Hz\* [par. 22-84 - par. 4-19 Hz]

**Function:**

Resolution 0.033 Hz.

Only visible when par. 22-82 *Work Point Calculation* is set to *Disable*. The speed of the motor at which the system design working point is achieved should be entered here in Hz. Alternatively, the speed in RPM can be entered in par. 22-85 *Speed at Design Point [RPM]*. If it has been decided to use Hz in par. 0-02 *Motor Speed Unit*, then par. 22-83 *Speed at No-Flow [RPM]* should also be used.

### 22-87 Pressure at No-Flow Speed

**Range:**

0.000 N/A\* [0.000 - par. 22-88 N/A]

**Function:**

Enter the pressure  $H_{MIN}$  corresponding to Speed at No Flow in Reference/Feedback Units.

### 22-88 Pressure at Rated Speed

**Range:**

999999.999 N/A\* [par. 22-87 - 999999.999 N/A]

**Function:**

Enter the value corresponding to the Pressure at Rated Speed, in Reference/Feedback Units. This value can be defined using the pump datasheet.

## 22-90 Flow at Rated Speed

**Range:**

0.000 N/A\* [0.000 - 999999.999 N/A]

**Function:**

Enter the value corresponding to Flow at Rated Speed. This value can be defined using the pump datasheet.

### 8.2.11 23-0\* Timed Actions

Use *Timed Actions* for actions needing to be performed on a daily or weekly basis, e.g., different references for working hours / non-working hours. Up to 10 Timed Actions can be programmed in the adjustable frequency drive. The Timed Action number is selected from the list when entering parameter group 23-0\* from the LCP. par. 23-00 *ON Time* – par. 23-04 *Occurrence* then refer to the selected Timed Action number. Each timed action is divided into an ON time and an OFF time, in which two different actions may be performed.

The actions programmed in timed actions are merged with corresponding actions from digital inputs, control work via bus and Smart Logic Controller, according to merge rules set up in 8-5\*, digital/bus.



**NOTE!**

The clock (parameter group 0-7\*) must be correctly programmed for timed actions to function correctly.



**NOTE!**

When mounting an Analog I/O MCB109 option card, a battery backup of the date and time is included.

**NOTE!**

The PC-based configuration tool MCT 10 includes a special guide for easy programming of timed actions.

## 23-00 ON Time

Array [10]

**Range:**

0 N/A\* [0 - 0 N/A]

**Function:**

Sets the ON time for the timed action.



**NOTE!**

The adjustable frequency drive has no backup of the clock function and the set date/time will reset to default (2000-01-01 00:00) after a power-down unless a Real Time Clock module with backup is installed. In par. 0-79 *Clock Fault*, it is possible to program a warning for cases when the clock has not been set properly, e.g., after a power-down.

## 23-01 ON Action

Arra [10]

**Option:**

**Function:**

Select the action during ON Time. See par. 13-52 *SL Controller Action* for descriptions of the options.

[0] \* DISABLED

[1] No action

[2]	Select set-up 1
[3]	Select set-up 2
[4]	Select set-up 3
[5]	Select set-up 4
[10]	Select preset ref 0
[11]	Select preset ref 1
[12]	Select preset ref 2
[13]	Select preset ref 3
[14]	Select preset ref 4
[15]	Select preset ref 5
[16]	Select preset ref 6
[17]	Select preset ref 7
[18]	Select ramp 1
[19]	Select ramp 2
[22]	Run
[23]	Run reverse
[24]	Stop
[26]	Dcstop
[27]	Coast
[28]	Freeze output
[29]	Start timer 0
[30]	Start timer 1
[31]	Start timer 2
[32]	Set digital out A low
[33]	Set digital out B low
[34]	Set digital out C low
[35]	Set digital out D low
[36]	Set digital out E low
[37]	Set digital out F low
[38]	Set digital out A high
[39]	Set digital out B high
[40]	Set digital out C high
[41]	Set digital out D high
[42]	Set digital out E high
[43]	Set digital out F high
[60]	Reset Counter A
[61]	Reset Counter B
[70]	Start Timer 3
[71]	Start Timer 4
[72]	Start Timer 5
[73]	Start Timer 6
[74]	Start Timer 7

**NOTE!**

For choices [32] - [43], see also par. group 5-3\*, *Digital Outputs* and 5-4\*, *Relays*.

**23-02 OFF Time**

Array [10]

**Range:**

0 N/A\* [0 - 0 N/A]

**Function:**

Sets the OFF time for the timed action.



**NOTE!**

The adjustable frequency drive has no backup of the clock function and the set date/time will reset to default (2000-01-01 00:00) after a power-down unless a Real Time Clock module with backup is installed. In par. 0-79 *Clock Fault*, it is possible to program a warning for cases when the clock has not been set properly, e.g., after a power-down.

**23-03 OFF Action**

Array [10]

**Option:**

**Function:**

Select the action during OFF Time. See par. 13-52 *SL Controller Action* for descriptions of the options.

- [0] \* DISABLED
- [1] No action
- [2] Select set-up 1
- [3] Select set-up 2
- [4] Select set-up 3
- [5] Select set-up 4
- [10] Select preset ref 0
- [11] Select preset ref 1
- [12] Select preset ref 2
- [13] Select preset ref 3
- [14] Select preset ref 4
- [15] Select preset ref 5
- [16] Select preset ref 6
- [17] Select preset ref 7
- [18] Select ramp 1
- [19] Select ramp 2
- [22] Run
- [23] Run reverse
- [24] Stop
- [26] Dcstop
- [27] Coast
- [28] Freeze output
- [29] Start timer 0
- [30] Start timer 1
- [31] Start timer 2



[32]	Set digital out A low
[33]	Set digital out B low
[34]	Set digital out C low
[35]	Set digital out D low
[36]	Set digital out E low
[37]	Set digital out F low
[38]	Set digital out A high
[39]	Set digital out B high
[40]	Set digital out C high
[41]	Set digital out D high
[42]	Set digital out E high
[43]	Set digital out F high
[60]	Reset Counter A
[61]	Reset Counter B
[70]	Start Timer 3
[71]	Start Timer 4
[72]	Start Timer 5
[73]	Start Timer 6
[74]	Start Timer 7

8

**23-04 Occurrence**

Array [10]

**Option:**

**Function:**

Select the day(s) to which the timed action applies. Specify working/non-working days in par. 0-81 *Working Days*, par. 0-82 *Additional Working Days* and par. 0-83 *Additional Non-Working Days*.

[0] *	All days
[1]	Working days
[2]	Non-working days
[3]	Monday
[4]	Tuesday
[5]	Wednesday
[6]	Thursday
[7]	Friday
[8]	Saturday
[9]	Sunday

**8.2.12 Water Application Functions, 29-\*\***

The group contains parameters used for monitoring water/wastewater applications.

**29-00 Pipe Fill Enable**

**Option:**

**Function:**

[0] *	Disabled	Select Enabled to fill pipes at a user-specified rate.
[1]	Enabled	Select Enabled to fill pipes with a user specified rate.

### 29-01 Pipe Fill Speed [RPM]

**Range:**

Speed Low [Speed Low Limit - Speed High Limit\*  
Limit\* it]

**Function:**

Set the filling speed for filling horizontal pipe systems. The speed can be selected in Hz or RPM depending on the choices made in par. 4-11 / par. 4-13 (RPM) or in par. 4-12 / par. 4-14 (Hz).

### 29-02 Pipe Fill Speed [Hz]

**Range:**

Motor [Speed Low Limit - Speed High Limit\*  
Speed Low it]  
Limit\*

**Function:**

Set the filling speed for filling horizontal pipe systems. The speed can be selected in Hz or RPM depending on the choices made in par. 4-11 / par. 4-13 (RPM) or in par. 4-12 / par. 4-14 (Hz).

### 29-03 Pipe Fill Time

**Range:**

0 s\* [0–3600 s]

**Function:**

Set the specified time for pipe filling of horizontal pipe systems.

### 29-04 Pipe Fill Rate

**Range:**

0.001 units/ [0.001–999999.999 units/s]  
s\*

**Function:**

Specifies the filling rate in units/second using the PI controller. Filling rate units are feedback units/second. This function is used for filling vertical pipe systems but will be active when the filling time has expired, no matter what, until the pipe fill setpoint set in par. 29-05 is reached.

### 29-05 Filled Setpoint

**Range:**

0 s\* [0–999999,999 s]

**Function:**

Specifies the filled setpoint at which the pipe fill function will be disabled and the PID controller will take control. This function can be used both for horizontal and vertical pipe systems.

## 8.3 Parameter Options

### 8.3.1 Default Settings

Changes during operation:

“TRUE” means that the parameter can be changed while the adjustable frequency drive is in operation, and “FALSE” means that the adjustable frequency drive must be stopped before a change can be made.

4 set-up:

'All set-up': the parameter can be set individually in each of the four set-ups, i. e., one single parameter can have four different data values.

'1 set-up': data value will be the same in all set-ups.

SR:

Size related

N/A:

No default value available.

Conversion index:

This number refers to a conversion figure used when writing or reading by means of an adjustable frequency drive.

<b>Conv. index</b>	100	67	6	5	4	3	2	1	0	-1	-2	-3	-4	-5	-6
<b>Conv. factor</b>	1	1/60	1000000	100000	10000	1000	100	10	1	0.1	0.01	0.001	0.0001	0.00001	0.000001

8

Data type	Description	Type
2	Integer 8	Int8
3	Integer 16	Int16
4	Integer 32	Int32
5	Unsigned 8	UInt8
6	Unsigned 16	UInt16
7	Unsigned 32	UInt32
9	Visible String	VisStr
33	Normalized value 2 bytes	N2
35	Bit sequence of 16 Boolean variables	V2
54	Time difference w/o date	TimD

### 8.3.2 Operation/Display 0-\*\*

Par. No. #	Parameter description	Default value	4-set-up	Change during operation	Conversion index	Type
<b>0-0* Basic Settings</b>						
0-01	Language	[0] English	1 set-up	TRUE	-	Uint8
0-02	Motor Speed Unit	[0] RPM	2 set-ups	FALSE	-	Uint8
0-03	Regional Settings	[0] International	2 set-ups	FALSE	-	Uint8
0-04	Operating State at Power-up	[0] Resume	All set-ups	TRUE	-	Uint8
0-05	Local Mode Unit	[0] As Motor Speed Unit	2 set-ups	FALSE	-	Uint8
<b>0-1* Set-up Operations</b>						
0-10	Active Set-up	[1] Set-up 1	1 set-up	TRUE	-	Uint8
0-11	Programming Set-up	[9] Active Set-up	All set-ups	TRUE	-	Uint8
0-12	This Set-up Linked to	[0] Not linked	All set-ups	FALSE	-	Uint8
0-13	Readout: Linked Set-ups	0 N/A	All set-ups	FALSE	0	Uint16
0-14	Readout: Prog. Set-ups / Channel	0 N/A	All set-ups	TRUE	0	Int32
<b>0-2* LCP Display</b>						
0-20	Display Line 1.1 Small	1601	All set-ups	TRUE	-	Uint16
0-21	Display Line 1.2 Small	1662	All set-ups	TRUE	-	Uint16
0-22	Display Line 1.3 Small	1614	All set-ups	TRUE	-	Uint16
0-23	Display Line 2 Large	1613	All set-ups	TRUE	-	Uint16
0-24	Display Line 3 Large	1652	All set-ups	TRUE	-	Uint16
0-25	My Personal Menu	ExpressionLimit	1 set-up	TRUE	0	Uint16
<b>0-3* LCP Cust. Readout</b>						
0-30	Custom Readout Unit	[1] %	All set-ups	TRUE	-	Uint8
0-31	Custom Readout Min Value	ExpressionLimit	All set-ups	TRUE	-2	Int32
0-32	Custom Readout Max Value	100.00 CustomReadoutUnit	All set-ups	TRUE	-2	Int32
0-37	Display Text 1	0 N/A	1 set-up	TRUE	0	VisStr[25]
0-38	Display Text 2	0 N/A	1 set-up	TRUE	0	VisStr[25]
0-39	Display Text 3	0 N/A	1 set-up	TRUE	0	VisStr[25]
<b>0-4* LCP Keypad</b>						
0-40	[Hand on] Key on LCP	[1] Enabled	All set-ups	TRUE	-	Uint8
0-41	[Off] Key on LCP	[1] Enabled	All set-ups	TRUE	-	Uint8
0-42	[Auto on] Key on LCP	[1] Enabled	All set-ups	TRUE	-	Uint8
0-43	[Reset] Key on LCP	[1] Enabled	All set-ups	TRUE	-	Uint8
0-44	[Off/Reset] Key on LCP	[1] Enabled	All set-ups	TRUE	-	Uint8
0-45	[Drive Bypass] Key on LCP	[1] Enabled	All set-ups	TRUE	-	Uint8
<b>0-5* Copy/Save</b>						
0-50	LCP Copy	[0] No copy	All set-ups	FALSE	-	Uint8
0-51	Set-up Copy	[0] No copy	All set-ups	FALSE	-	Uint8



Par. No. #	Parameter description	Default value	4-set-up	Change during operation	Conversion index	Type
<b>0-6* Password</b>						
0-60	Main Menu Password	100 N/A	1 set-up	TRUE	0	Uint16
0-61	Access to Main Menu w/o Password	[0] Full access	1 set-up	TRUE	-	Uint8
0-65	Personal Menu Password	200 N/A	1 set-up	TRUE	0	Uint16
0-66	Access to Personal Menu w/o Password	[0] Full access	1 set-up	TRUE	-	Uint8
<b>0-7* Clock Settings</b>						
0-70	Date and Time	ExpressionLimit	All set-ups	TRUE	0	TimeOfDay
0-71	Date Format	[0] YYYY-MM-DD	1 set-up	TRUE	-	Uint8
0-72	Time Format	[0] 24 h	1 set-up	TRUE	-	Uint8
0-74	DST/Summertime	[0] OFF	1 set-up	TRUE	-	Uint8
0-76	DST/Summertime Start	ExpressionLimit	1 set-up	TRUE	0	TimeOfDay
0-77	DST/Summertime End	ExpressionLimit	1 set-up	TRUE	0	TimeOfDay
0-79	Clock Fault	null	1 set-up	TRUE	-	Uint8
0-81	Working Days	null	1 set-up	TRUE	-	Uint8
0-82	Additional Working Days	ExpressionLimit	1 set-up	TRUE	0	TimeOfDay
0-83	Additional Non-Working Days	ExpressionLimit	1 set-up	TRUE	0	TimeOfDay
0-89	Date and Time Readout	0 N/A	All set-ups	TRUE	0	VisStr[25]

### 8.3.3 Load/Motor 1-\*\*-\*

Par. No. #	Parameter description	Default value	4-set-up	Change during operation	Conversion index	Type
<b>1-0* General Settings</b>						
1-00	Configuration Mode	null	All set-ups	TRUE	-	Uint8
1-01	Motor Control Principle	null	All set-ups	FALSE	-	Uint8
1-03	Torque Characteristics	[3] Auto Energy Optim. VT	All set-ups	TRUE	-	Uint8
<b>1-1* Motor Selection</b>						
1-10	Motor Construction	[0] Asynchronous	All set-ups	FALSE	-	Uint8
<b>1-2* Motor Data</b>						
1-20	Motor Power [kW]	ExpressionLimit	All set-ups	FALSE	1	Uint32
1-21	Motor Power [HP]	ExpressionLimit	All set-ups	FALSE	-2	Uint32
1-22	Motor Voltage	ExpressionLimit	All set-ups	FALSE	0	Uint16
1-23	Motor Frequency	ExpressionLimit	All set-ups	FALSE	0	Uint16
1-24	Motor Current	ExpressionLimit	All set-ups	FALSE	-2	Uint32
1-25	Motor Nominal Speed	ExpressionLimit	All set-ups	FALSE	67	Uint16
1-28	Motor Rotation Check	[0] OFF	All set-ups	FALSE	-	Uint8
1-29	Automatic Motor Adaptation (AMA)	[0] Off	All set-ups	FALSE	-	Uint8
<b>1-3* Addl. Motor Data</b>						
1-30	Stator Resistance (Rs)	ExpressionLimit	All set-ups	FALSE	-4	Uint32
1-31	Rotor Resistance (Rr)	ExpressionLimit	All set-ups	FALSE	-4	Uint32
1-32	Stator Reactance (Xs)	ExpressionLimit	All set-ups	FALSE	-4	Uint32
1-33	Stator Leakage Reactance (X1)	ExpressionLimit	All set-ups	FALSE	-4	Uint32
1-34	Rotor Leakage Reactance (X2)	ExpressionLimit	All set-ups	FALSE	-4	Uint32
1-35	Main Reactance (Xl)	ExpressionLimit	All set-ups	FALSE	-4	Uint32
1-36	Iron Loss Resistance (Rfe)	ExpressionLimit	All set-ups	FALSE	-3	Uint32
1-39	Motor Poles	ExpressionLimit	All set-ups	FALSE	0	Uint8
<b>1-5* Load-Indep. Setting</b>						
1-50	Motor Magnetization at Zero Speed	100 %	All set-ups	TRUE	0	Uint16
1-51	Min Speed Normal Magnetizing [RPM]	ExpressionLimit	All set-ups	TRUE	67	Uint16
1-52	Min Speed Normal Magnetizing [Hz]	ExpressionLimit	All set-ups	TRUE	-1	Uint16
1-55	U/f Characteristic - U	ExpressionLimit	All set-ups	TRUE	-1	Uint16
1-56	U/f Characteristic - F	ExpressionLimit	All set-ups	TRUE	-1	Uint16
<b>1-6* Load-Depend. Settng.</b>						
1-60	Low Speed Load Compensation	100 %	All set-ups	TRUE	0	Int16
1-61	High Speed Load Compensation	100 %	All set-ups	TRUE	0	Int16
1-62	Slip Compensation	0 %	All set-ups	TRUE	0	Int16
1-63	Slip Compensation Time Constant	ExpressionLimit	All set-ups	TRUE	-2	Uint16
1-64	Resonance Dampening	100 %	All set-ups	TRUE	0	Uint16
1-65	Resonance Dampening Time Constant	5 ms	All set-ups	TRUE	-3	Uint8
<b>1-7* Start Adjustments</b>						
1-71	Start Delay	0.0 s	All set-ups	TRUE	-1	Uint16
1-73	Flying Start	[0] Disabled	All set-ups	FALSE	-	Uint8
1-74	Start Speed [RPM]	ExpressionLimit	All set-ups	TRUE	67	Uint16
1-75	Start Speed [Hz]	ExpressionLimit	All set-ups	TRUE	-1	Uint16
1-76	Start Current	0.00 A	All set-ups	TRUE	-2	Uint32



Par. No. #	Parameter description	Default value	4-set-up	Change during operation	Conversion index	Type
<b>1-8* Stop Adjustments</b>						
1-80	Function at Stop	[0] Coast	All set-ups	TRUE	-	Uint8
1-81	Min Speed for Function at Stop [RPM]	ExpressionLimit	All set-ups	TRUE	67	Uint16
1-82	Min Speed for Function at Stop [Hz]	ExpressionLimit	All set-ups	TRUE	-1	Uint16
1-86	Trip Speed Low [RPM]	0 RPM	All set-ups	TRUE	67	Uint16
1-87	Trip Speed Low [Hz]	0 Hz	All set-ups	TRUE	-1	Uint16
<b>1-9* Motor Temperature</b>						
1-90	Motor Thermal Protection	[4] ETR trip 1	All set-ups	TRUE	-	Uint8
1-91	Motor External Fan	[0] No	All set-ups	TRUE	-	Uint16
1-93	Thermistor Source	[0] None	All set-ups	TRUE	-	Uint8

### 8.3.4 Brakes 2-\*\*-\*

Par. No. #	Parameter description	Default value	4-set-up	Change during operation	Conversion index	Type
<b>2-0* DC Brake</b>						
2-00	DC Hold/Preheat Current	50 %	All set-ups	TRUE	0	Uint8
2-01	DC Brake Current	50 %	All set-ups	TRUE	0	Uint16
2-02	DC Braking Time	10.0 s	All set-ups	TRUE	-1	Uint16
2-03	DC Brake Cut-in Speed [RPM]	ExpressionLimit	All set-ups	TRUE	67	Uint16
2-04	DC Brake Cut-in Speed [Hz]	ExpressionLimit	All set-ups	TRUE	-1	Uint16
<b>2-1* Brake Energy Funct.</b>						
2-10	Brake Function	[0] Off	All set-ups	TRUE	-	Uint8
2-11	Brake Resistor (ohm)	ExpressionLimit	All set-ups	TRUE	0	Uint16
2-12	Brake Power Limit (kW)	ExpressionLimit	All set-ups	TRUE	0	Uint32
2-13	Brake Power Monitoring	[0] Off	All set-ups	TRUE	-	Uint8
2-15	Brake Check	[0] Off	All set-ups	TRUE	-	Uint8
2-16	AC Brake Max. Current	100.0 %	All set-ups	TRUE	-1	Uint32
2-17	Over-voltage Control	[2] Enabled	All set-ups	TRUE	-	Uint8





**8.3.5 Reference / Ramps 3-\*\***

Par. No. #	Parameter description	Default value	4-set-up	Change during operation	Conversion index	Type
<b>3-0* Reference Limits</b>						
3-02	Minimum Reference	ExpressionLimit	All set-ups	TRUE	-3	Int32
3-03	Maximum Reference	ExpressionLimit	All set-ups	TRUE	-3	Int32
3-04	Reference Function	[0] Sum	All set-ups	TRUE	-	UInt8
<b>3-1* References</b>						
3-10	Preset Reference	0.00 %	All set-ups	TRUE	-2	Int16
3-11	Jog Speed [Hz]	ExpressionLimit	All set-ups	TRUE	-1	UInt16
3-13	Reference Site	[0] Linked to Hand / Auto	All set-ups	TRUE	-	Int8
3-14	Preset Relative Reference	0.00 %	All set-ups	TRUE	-2	Int32
3-15	Reference 1 Source	[1] Analog input 53	All set-ups	TRUE	-	UInt8
3-16	Reference 2 Source	[0] No function	All set-ups	TRUE	-	UInt8
3-17	Reference 3 Source	[0] No function	All set-ups	TRUE	-	UInt8
3-19	Jog Speed [RPM]	ExpressionLimit	All set-ups	TRUE	67	UInt16
<b>3-4* Ramp 1</b>						
3-41	Ramp 1 Ramp-up Time	ExpressionLimit	All set-ups	TRUE	-2	UInt32
3-42	Ramp 1 Ramp-down Time	ExpressionLimit	All set-ups	TRUE	-2	UInt32
<b>3-5* Ramp 2</b>						
3-51	Ramp 2 Ramp-up Time	ExpressionLimit	All set-ups	TRUE	-2	UInt32
3-52	Ramp 2 Ramp-down Time	ExpressionLimit	All set-ups	TRUE	-2	UInt32
<b>3-8* Other Ramps</b>						
3-80	Jog Ramp Time	ExpressionLimit	All set-ups	TRUE	-2	UInt32
3-81	Quick Stop Ramp Time	ExpressionLimit	2 set-ups	TRUE	-2	UInt32
3-84	Initial Ramp Time	0.00 s	All set-ups	TRUE	-2	UInt16
3-85	Check Valve Ramp Time	0.00 s	All set-ups	TRUE	-2	UInt16
3-86	Check Valve Ramp End Speed [RPM]	ExpressionLimit	All set-ups	TRUE	67	UInt16
3-87	Check Valve Ramp End Speed [Hz]	ExpressionLimit	All set-ups	TRUE	-1	UInt16
3-88	Final Ramp Time	0.00 s	All set-ups	TRUE	-2	UInt16
<b>3-9* Digital Pot. meter</b>						
3-90	Step Size	0.10 %	All set-ups	TRUE	-2	UInt16
3-91	Ramp Time	1.00 s	All set-ups	TRUE	-2	UInt32
3-92	Power Restore	[0] Off	All set-ups	TRUE	-	UInt8
3-93	Maximum Limit	100 %	All set-ups	TRUE	0	Int16
3-94	Minimum Limit	0 %	All set-ups	TRUE	0	Int16
3-95	Ramp Delay	ExpressionLimit	All set-ups	TRUE	-3	TimD

### 8.3.6 Limits / Warnings 4-\*\*-\*

Par. No. #	Parameter description	Default value	4-set-up	Change during operation	Conversion index	Type
<b>4-1* Motor Limits</b>						
4-10	Motor Speed Direction	[0] Clockwise	All set-ups	FALSE	-	Uint8
4-11	Motor Speed Low Limit [RPM]	ExpressionLimit	All set-ups	TRUE	67	Uint16
4-12	Motor Speed Low Limit [Hz]	ExpressionLimit	All set-ups	TRUE	-1	Uint16
4-13	Motor Speed High Limit [RPM]	ExpressionLimit	All set-ups	TRUE	67	Uint16
4-14	Motor Speed High Limit [Hz]	ExpressionLimit	All set-ups	TRUE	-1	Uint16
4-16	Torque Limit Motor Mode	ExpressionLimit	All set-ups	TRUE	-1	Uint16
4-17	Torque Limit Generator Mode	100.0 %	All set-ups	TRUE	-1	Uint16
4-18	Current Limit	ExpressionLimit	All set-ups	TRUE	-1	Uint32
4-19	Max Output Frequency	ExpressionLimit	All set-ups	FALSE	-1	Uint16
<b>4-5* Adj. Warnings</b>						
4-50	Warning Current Low	0.00 A	All set-ups	TRUE	-2	Uint32
4-51	Warning Current High	ImaxVLT (P1637)	All set-ups	TRUE	-2	Uint32
4-52	Warning Speed Low	0 RPM	All set-ups	TRUE	67	Uint16
4-53	Warning Speed High	outputSpeedHighLimit (P413)	All set-ups	TRUE	67	Uint16
4-54	Warning Reference Low	-999999,999 N/A	All set-ups	TRUE	-3	Int32
4-55	Warning Reference High	999999,999 N/A	All set-ups	TRUE	-3	Int32
4-56	Warning Feedback Low	-999999,999 ReferenceFeedbackUnit	All set-ups	TRUE	-3	Int32
4-57	Warning Feedback High	999999,999 ReferenceFeedbackUnit	All set-ups	TRUE	-3	Int32
4-58	Missing Motor Phase Function	[2] Trip 1000 ms	All set-ups	TRUE	-	Uint8
<b>4-6* Speed Bypass</b>						
4-60	Bypass Speed From [RPM]	ExpressionLimit	All set-ups	TRUE	67	Uint16
4-61	Bypass Speed From [Hz]	ExpressionLimit	All set-ups	TRUE	-1	Uint16
4-62	Bypass Speed To [RPM]	ExpressionLimit	All set-ups	TRUE	67	Uint16
4-63	Bypass Speed To [Hz]	ExpressionLimit	All set-ups	TRUE	-1	Uint16
4-64	Semi-Auto Bypass Set-up	[0] OFF	All set-ups	FALSE	-	Uint8



**8.3.7 Digital In/Out 5-\*\***

Par. No. #	Parameter description	Default value	4-set-up	Change during operation	Conversion index	Type
<b>5-0* Digital I/O mode</b>						
5-00	Digital I/O Mode	[0] PNP - Active at 24 V	All set-ups	FALSE	-	Uint8
5-01	Terminal 27 Mode	[0] Input	All set-ups	TRUE	-	Uint8
5-02	Terminal 29 Mode	[0] Input	All set-ups	TRUE	-	Uint8
<b>5-1* Digital Inputs</b>						
5-10	Terminal 18 Digital Input	[8] Start	All set-ups	TRUE	-	Uint8
5-11	Terminal 19 Digital Input	[0] No operation	All set-ups	TRUE	-	Uint8
5-12	Terminal 27 Digital Input	null	All set-ups	TRUE	-	Uint8
5-13	Terminal 29 Digital Input	[0] No operation	All set-ups	TRUE	-	Uint8
5-14	Terminal 32 Digital Input	[0] No operation	All set-ups	TRUE	-	Uint8
5-15	Terminal 33 Digital Input	[0] No operation	All set-ups	TRUE	-	Uint8
5-16	Terminal X30/2 Digital Input	[0] No operation	All set-ups	TRUE	-	Uint8
5-17	Terminal X30/3 Digital Input	[0] No operation	All set-ups	TRUE	-	Uint8
5-18	Terminal X30/4 Digital Input	[0] No operation	All set-ups	TRUE	-	Uint8
<b>5-3* Digital Outputs</b>						
5-30	Terminal 27 Digital Output	[0] No operation	All set-ups	TRUE	-	Uint8
5-31	Terminal 29 digital Output	[0] No operation	All set-ups	TRUE	-	Uint8
5-32	Term X30/6 Digi Out (MCB 101)	[0] No operation	All set-ups	TRUE	-	Uint8
5-33	Term X30/7 Digi Out (MCB 101)	[0] No operation	All set-ups	TRUE	-	Uint8
<b>5-4* Relays</b>						
5-40	Function Relay	null	All set-ups	TRUE	-	Uint8
5-41	On Delay, Relay	0.01 s	All set-ups	TRUE	-2	Uint16
5-42	Off Delay, Relay	0.01 s	All set-ups	TRUE	-2	Uint16
<b>5-5* Pulse Input</b>						
5-50	Term. 29 Low Frequency	100 Hz	All set-ups	TRUE	0	Uint32
5-51	Term. 29 High Frequency	100 Hz	All set-ups	TRUE	0	Uint32
5-52	Term. 29 Low Ref./Feedb. Value	0.000 N/A	All set-ups	TRUE	-3	Int32
5-53	Term. 29 High Ref./Feedb. Value	100,000 N/A	All set-ups	TRUE	-3	Int32
5-54	Pulse Filter Time Constant #29	100 ms	All set-ups	FALSE	-3	Uint16
5-55	Term. 33 Low Frequency	100 Hz	All set-ups	TRUE	0	Uint32
5-56	Term. 33 High Frequency	100 Hz	All set-ups	TRUE	0	Uint32
5-57	Term. 33 Low Ref./Feedb. Value	0.000 N/A	All set-ups	TRUE	-3	Int32
5-58	Term. 33 High Ref./Feedb. Value	100,000 N/A	All set-ups	TRUE	-3	Int32
5-59	Pulse Filter Time Constant #33	100 ms	All set-ups	FALSE	-3	Uint16
<b>5-6* Pulse Output</b>						
5-60	Terminal 27 Pulse Output Variable	[0] No operation	All set-ups	TRUE	-	Uint8
5-62	Pulse Output Max Freq #27	5000 Hz	All set-ups	TRUE	0	Uint32
5-63	Terminal 29 Pulse Output Variable	[0] No operation	All set-ups	TRUE	-	Uint8
5-65	Pulse Output Max Freq #29	5000 Hz	All set-ups	TRUE	0	Uint32
5-66	Terminal X30/6 Pulse Output Variable	[0] No operation	All set-ups	TRUE	-	Uint8
5-68	Pulse Output Max Freq #X30/6	5000 Hz	All set-ups	TRUE	0	Uint32
<b>5-9* Bus Controlled</b>						
5-90	Digital & Relay Bus Control	0 N/A	All set-ups	TRUE	0	Uint32
5-93	Pulse Out #27 Bus Control	0.00 %	All set-ups	TRUE	-2	N2
5-94	Pulse Out #27 Timeout Preset	0.00 %	1 set-up	TRUE	-2	Uint16
5-95	Pulse Out #29 Bus Control	0.00 %	All set-ups	TRUE	-2	N2
5-96	Pulse Out #29 Timeout Preset	0.00 %	1 set-up	TRUE	-2	Uint16
5-97	Pulse Out #X30/6 Bus Control	0.00 %	All set-ups	TRUE	-2	N2
5-98	Pulse Out #X30/6 Timeout Preset	0.00 %	1 set-up	TRUE	-2	Uint16

### 8.3.8 Analog In/Out 6-\*\*\*

Par. No. #	Parameter description	Default value	4-set-up	Change during operation	Conversion index	Type
<b>6-0* Analog I/O Mode</b>						
6-00	Live Zero Timeout Time	10 s	All set-ups	TRUE	0	Uint8
6-01	Live Zero Timeout Function	[0] Off	All set-ups	TRUE	-	Uint8
<b>6-1* Analog Input 53</b>						
6-10	Terminal 53 Low Voltage	0.07 V	All set-ups	TRUE	-2	Int16
6-11	Terminal 53 High Voltage	10.00 V	All set-ups	TRUE	-2	Int16
6-12	Terminal 53 Low Current	4.00 mA	All set-ups	TRUE	-5	Int16
6-13	Terminal 53 High Current	20.00 mA	All set-ups	TRUE	-5	Int16
6-14	Terminal 53 Low Ref./Feedb. Value	0.000 N/A	All set-ups	TRUE	-3	Int32
6-15	Terminal 53 High Ref./Feedb. Value	ExpressionLimit	All set-ups	TRUE	-3	Int32
6-16	Terminal 53 Filter Time Constant	0.001 s	All set-ups	TRUE	-3	Uint16
6-17	Terminal 53 Live Zero	[1] Enabled	All set-ups	TRUE	-	Uint8
<b>6-2* Analog Input 54</b>						
6-20	Terminal 54 Low Voltage	0.07 V	All set-ups	TRUE	-2	Int16
6-21	Terminal 54 High Voltage	10.00 V	All set-ups	TRUE	-2	Int16
6-22	Terminal 54 Low Current	4.00 mA	All set-ups	TRUE	-5	Int16
6-23	Terminal 54 High Current	20.00 mA	All set-ups	TRUE	-5	Int16
6-24	Terminal 54 Low Ref./Feedb. Value	0.000 N/A	All set-ups	TRUE	-3	Int32
6-25	Terminal 54 High Ref./Feedb. Value	100.000 N/A	All set-ups	TRUE	-3	Int32
6-26	Terminal 54 Filter Time Constant	0.001 s	All set-ups	TRUE	-3	Uint16
6-27	Terminal 54 Live Zero	[1] Enabled	All set-ups	TRUE	-	Uint8
<b>6-3* Analog Input X30/11</b>						
6-30	Terminal X30/11 Low Voltage	0.07 V	All set-ups	TRUE	-2	Int16
6-31	Terminal X30/11 High Voltage	10.00 V	All set-ups	TRUE	-2	Int16
6-34	Term. X30/11 Low Ref./Feedb. Value	0.000 N/A	All set-ups	TRUE	-3	Int32
6-35	Term. X30/11 High Ref./Feedb. Value	100.000 N/A	All set-ups	TRUE	-3	Int32
6-36	Term. X30/11 Filter Time Constant	0.001 s	All set-ups	TRUE	-3	Uint16
6-37	Term. X30/11 Live Zero	[1] Enabled	All set-ups	TRUE	-	Uint8
<b>6-4* Analog Input X30/12</b>						
6-40	Terminal X30/12 Low Voltage	0.07 V	All set-ups	TRUE	-2	Int16
6-41	Terminal X30/12 High Voltage	10.00 V	All set-ups	TRUE	-2	Int16
6-44	Term. X30/12 Low Ref./Feedb. Value	0.000 N/A	All set-ups	TRUE	-3	Int32
6-45	Term. X30/12 High Ref./Feedb. Value	100.000 N/A	All set-ups	TRUE	-3	Int32
6-46	Term. X30/12 Filter Time Constant	0.001 s	All set-ups	TRUE	-3	Uint16
6-47	Term. X30/12 Live Zero	[1] Enabled	All set-ups	TRUE	-	Uint8
<b>6-5* Analog Output 42</b>						
6-50	Terminal 42 Output	[100] Output freq. 0-100	All set-ups	TRUE	-	Uint8
6-51	Terminal 42 Output Min Scale	0.00 %	All set-ups	TRUE	-2	Int16
6-52	Terminal 42 Output Max Scale	100.00 %	All set-ups	TRUE	-2	Int16
6-53	Terminal 42 Output Bus Control	0.00 %	All set-ups	TRUE	-2	N2
6-54	Terminal 42 Output Timeout Preset	0.00 %	1 set-up	TRUE	-2	Uint16
<b>6-6* Analog Output X30/8</b>						
6-60	Terminal X30/8 Output	[0] No operation	All set-ups	TRUE	-	Uint8
6-61	Terminal X30/8 Min. Scale	0.00 %	All set-ups	TRUE	-2	Int16
6-62	Terminal X30/8 Max. Scale	100.00 %	All set-ups	TRUE	-2	Int16
6-63	Terminal X30/8 Output Bus Control	0.00 %	All set-ups	TRUE	-2	N2
6-64	Terminal X30/8 Output Timeout Preset	0.00 %	1 set-up	TRUE	-2	Uint16



**8.3.9 Comm. and Options 8-\*\*-**

Par. No. #	Parameter description	Default value	4-set-up	Change during operation	Conversion index	Type
<b>8-0* General Settings</b>						
8-01	Control Site	null	All set-ups	TRUE	-	Uint8
8-02	Control Source	null	All set-ups	TRUE	-	Uint8
8-03	Control Timeout Time	ExpressionLimit	1 set-up	TRUE	-1	Uint32
8-04	Control Timeout Function	[0] Off	1 set-up	TRUE	-	Uint8
8-05	End-of-Timeout Function	[1] Resume set-up	1 set-up	TRUE	-	Uint8
8-06	Reset Control Timeout	[0] Do not reset	All set-ups	TRUE	-	Uint8
8-07	Diagnosis Trigger	[0] Disable	2 set-ups	TRUE	-	Uint8
<b>8-1* Control Settings</b>						
8-10	Control Profile	[0] FC profile	All set-ups	TRUE	-	Uint8
8-13	Configurable Status Word STW	[1] Profile Default	All set-ups	TRUE	-	Uint8
8-14	Configurable Control Word CTW	[1] Profile default	All set-ups	TRUE	-	Uint8
<b>8-3* FC Port Settings</b>						
8-30	Protocol	null	1 set-up	TRUE	-	Uint8
8-31	Address	ExpressionLimit	1 set-up	TRUE	0	Uint8
8-32	Baud Rate	null	1 set-up	TRUE	-	Uint8
8-33	Parity / Stop Bits	null	1 set-up	TRUE	-	Uint8
8-35	Minimum Response Delay	ExpressionLimit	1 set-up	TRUE	-3	Uint16
8-36	Max Response Delay	ExpressionLimit	1 set-up	TRUE	-3	Uint16
8-37	Maximum Inter-Char Delay	ExpressionLimit	1 set-up	TRUE	-5	Uint16
<b>8-4* FC MC protocol set</b>						
8-40	Telegram selection	[1] Standard telegram 1	2 set-ups	TRUE	-	Uint8
<b>8-5* Digital / Bus</b>						
8-50	Coasting Select	[3] Logic OR	All set-ups	TRUE	-	Uint8
8-52	DC Brake Select	[3] Logic OR	All set-ups	TRUE	-	Uint8
8-53	Start Select	[3] Logic OR	All set-ups	TRUE	-	Uint8
8-54	Reverse Select	null	All set-ups	TRUE	-	Uint8
8-55	Set-up Select	[3] Logic OR	All set-ups	TRUE	-	Uint8
8-56	Preset Reference Select	[3] Logic OR	All set-ups	TRUE	-	Uint8
<b>8-7* BACnet</b>						
8-70	BACnet Device Instance	1 N/A	1 set-up	TRUE	0	Uint32
8-72	MS/TP Max Masters	127 N/A	1 set-up	TRUE	0	Uint8
8-73	MS/TP Max Info Frames	1 N/A	1 set-up	TRUE	0	Uint16
8-74	"Startup I am"	[0] Send at power-up	1 set-up	TRUE	-	Uint8
8-75	Initialization Password	ExpressionLimit	1 set-up	TRUE	0	VisStr[20]
<b>8-8* FC Port Diagnostics</b>						
8-80	Bus Message Count	0 N/A	All set-ups	TRUE	0	Uint32
8-81	Bus Error Count	0 N/A	All set-ups	TRUE	0	Uint32
8-82	Slave Message Rcvd	0 N/A	All set-ups	TRUE	0	Uint32
8-83	Slave Error Count	0 N/A	All set-ups	TRUE	0	Uint32
<b>8-9* Bus Jog</b>						
8-90	Bus Jog 1 Speed	100 RPM	All set-ups	TRUE	67	Uint16
8-91	Bus Jog 2 Speed	200 RPM	All set-ups	TRUE	67	Uint16
8-94	Bus Feedback 1	0 N/A	1 set-up	TRUE	0	N2
8-95	Bus Feedback 2	0 N/A	1 set-up	TRUE	0	N2
8-96	Bus Feedback 3	0 N/A	1 set-up	TRUE	0	N2

### 8.3.10 Profibus 9-\*\*-\*

Par. No. #	Parameter description	Default value	4-set-up	Change during operation	Conversion index	Type
9-00	Setpoint	0 N/A	All set-ups	TRUE	0	Uint16
9-07	Actual Value	0 N/A	All set-ups	FALSE	0	Uint16
9-15	PCD Write Configuration	ExpressionLimit	2 set-ups	TRUE	-	Uint16
9-16	PCD Read Configuration	ExpressionLimit	2 set-ups	TRUE	-	Uint16
9-18	Node Address	126 N/A	1 set-up	TRUE	0	Uint8
9-22	Telegram Selection	[108] PPO 8	1 set-up	TRUE	-	Uint8
9-23	Parameters for Signals	0	All set-ups	TRUE	-	Uint16
9-27	Parameter Edit	[1] Enabled	2 set-ups	FALSE	-	Uint16
9-28	Process Control	[1] Enable cyclic master	2 set-ups	FALSE	-	Uint8
9-44	Fault Message Counter	0 N/A	All set-ups	TRUE	0	Uint16
9-45	Fault Code	0 N/A	All set-ups	TRUE	0	Uint16
9-47	Fault Number	0 N/A	All set-ups	TRUE	0	Uint16
9-52	Fault Situation Counter	0 N/A	All set-ups	TRUE	0	Uint16
9-53	Profibus Warning Word	0 N/A	All set-ups	TRUE	0	V2
9-63	Actual Baud Rate	[255] No baud rate found	All set-ups	TRUE	-	Uint8
9-64	Device Identification	0 N/A	All set-ups	TRUE	0	Uint16
9-65	Profile Number	0 N/A	All set-ups	TRUE	0	OctStr[2]
9-67	Control Word 1	0 N/A	All set-ups	TRUE	0	V2
9-68	Status Word 1	0 N/A	All set-ups	TRUE	0	V2
9-71	Profibus Save Data Values	[0] Off	All set-ups	TRUE	-	Uint8
9-72	ProfibusDriveReset	[0] No action	1 set-up	FALSE	-	Uint8
9-80	Defined Parameters (1)	0 N/A	All set-ups	FALSE	0	Uint16
9-81	Defined Parameters (2)	0 N/A	All set-ups	FALSE	0	Uint16
9-82	Defined Parameters (3)	0 N/A	All set-ups	FALSE	0	Uint16
9-83	Defined Parameters (4)	0 N/A	All set-ups	FALSE	0	Uint16
9-84	Defined Parameters (5)	0 N/A	All set-ups	FALSE	0	Uint16
9-90	Changed Parameters (1)	0 N/A	All set-ups	FALSE	0	Uint16
9-91	Changed Parameters (2)	0 N/A	All set-ups	FALSE	0	Uint16
9-92	Changed Parameters (3)	0 N/A	All set-ups	FALSE	0	Uint16
9-93	Changed Parameters (4)	0 N/A	All set-ups	FALSE	0	Uint16
9-94	Changed parameters (5)	0 N/A	All set-ups	FALSE	0	Uint16

**8.3.1.1 CAN Fieldbus 10-.\***

Par. No. #	Parameter description	Default value	4-set-up	Change during operation	Conversion index	Type
<b>10-0* Common Settings</b>						
10-00	CAN Protocol	null	2 set-ups	FALSE	-	Uint8
10-01	Baud Rate Select	null	2 set-ups	TRUE	-	Uint8
10-02	MAC ID	ExpressionLimit	2 set-ups	TRUE	0	Uint8
10-05	Readout Transmit Error Counter	0 N/A	All set-ups	TRUE	0	Uint8
10-06	Readout Receive Error Counter	0 N/A	All set-ups	TRUE	0	Uint8
10-07	Readout Bus Off Counter	0 N/A	All set-ups	TRUE	0	Uint8
<b>10-1* DeviceNet</b>						
10-10	Process Data Type Selection	null	All set-ups	TRUE	-	Uint8
10-11	Process Data Config Write	ExpressionLimit	2 set-ups	TRUE	-	Uint16
10-12	Process Data Config Read	ExpressionLimit	2 set-ups	TRUE	-	Uint16
10-13	Warning Parameter	0 N/A	All set-ups	TRUE	0	Uint16
10-14	Net Reference	[0] Off	2 set-ups	TRUE	-	Uint8
10-15	Net Control	[0] Off	2 set-ups	TRUE	-	Uint8
<b>10-2* COS Filters</b>						
10-20	COS Filter 1	0 N/A	All set-ups	FALSE	0	Uint16
10-21	COS Filter 2	0 N/A	All set-ups	FALSE	0	Uint16
10-22	COS Filter 3	0 N/A	All set-ups	FALSE	0	Uint16
10-23	COS Filter 4	0 N/A	All set-ups	FALSE	0	Uint16
<b>10-3* Parameter Access</b>						
10-30	Array Index	0 N/A	2 set-ups	TRUE	0	Uint8
10-31	Store Data Values	[0] Off	All set-ups	TRUE	-	Uint8
10-32	DeviceNet Revision	ExpressionLimit	All set-ups	TRUE	0	Uint16
10-33	Store Always	[0] Off	1 set-up	TRUE	-	Uint8
10-34	DeviceNet Product Code	130 N/A	1 set-up	TRUE	0	Uint16
10-39	DeviceNet F Parameters	0 N/A	All set-ups	TRUE	0	Uint32

### 8.3.12 Smart Logic 13-\*\*-\*

Par. No. #	Parameter description	Default value	4-set-up	Change during operation	Conversion index	Type
<b>13-0* SLC Settings</b>						
13-00	SL Controller Mode	null	2 set-ups	TRUE	-	Uint8
13-01	Start Event	null	2 set-ups	TRUE	-	Uint8
13-02	Stop Event	null	2 set-ups	TRUE	-	Uint8
13-03	Reset SLC	[0] Do not reset SLC	All set-ups	TRUE	-	Uint8
<b>13-1* Comparators</b>						
13-10	Comparator Operand	null	2 set-ups	TRUE	-	Uint8
13-11	Comparator Operator	null	2 set-ups	TRUE	-	Uint8
13-12	Comparator Value	ExpressionLimit	2 set-ups	TRUE	-3	Int32
<b>13-2* Timers</b>						
13-20	SL Controller Timer	ExpressionLimit	1 set-up	TRUE	-3	TimD
<b>13-4* Logic Rules</b>						
13-40	Logic Rule Boolean 1	null	2 set-ups	TRUE	-	Uint8
13-41	Logic Rule Operator 1	null	2 set-ups	TRUE	-	Uint8
13-42	Logic Rule Boolean 2	null	2 set-ups	TRUE	-	Uint8
13-43	Logic Rule Operator 2	null	2 set-ups	TRUE	-	Uint8
13-44	Logic Rule Boolean 3	null	2 set-ups	TRUE	-	Uint8
<b>13-5* States</b>						
13-51	SL Controller Event	null	2 set-ups	TRUE	-	Uint8
13-52	SL Controller Action	null	2 set-ups	TRUE	-	Uint8





### 8.3.13 Special Functions 14-\*\*-\*

Par. No. #	Parameter description	Default value	4-set-up	Change during operation	Conversion index	Type
<b>14-0* Inverter Switching</b>						
14-00	Switching Pattern	null	All set-ups	TRUE	-	Uint8
14-01	Switching Frequency	null	All set-ups	TRUE	-	Uint8
14-03	Overmodulation	[1] On	All set-ups	FALSE	-	Uint8
14-04	PWM Random	[0] Off	All set-ups	TRUE	-	Uint8
<b>14-1* Mains On/Off</b>						
14-10	Line Failure	[0] No function	All set-ups	FALSE	-	Uint8
14-11	Line Voltage at Line Fault	ExpressionLimit	All set-ups	TRUE	0	Uint16
14-12	Function at Mains Imbalance	[3] Derate	All set-ups	TRUE	-	Uint8
<b>14-2* Reset Functions</b>						
14-20	Reset Mode	[10] Automatic reset x 10	All set-ups	TRUE	-	Uint8
14-21	Automatic Restart Time	10 s	All set-ups	TRUE	0	Uint16
14-22	Operation Mode	[0] Normal operation	All set-ups	TRUE	-	Uint8
14-23	Typecode Setting	null	2 set-ups	FALSE	-	Uint8
14-25	Trip Delay at Torque Limit	60 s	All set-ups	TRUE	0	Uint8
14-26	Trip Delay at Inverter Fault	ExpressionLimit	All set-ups	TRUE	0	Uint8
14-28	Production Settings	[0] No action	All set-ups	TRUE	-	Uint8
14-29	Service Code	0 N/A	All set-ups	TRUE	0	Int32
<b>14-3* Current Limit Ctrl.</b>						
14-30	Current Lim Contr, Proportional Gain	100 %	All set-ups	FALSE	0	Uint16
14-31	Current Lim Contr, Integration Time	0.020 s	All set-ups	FALSE	-3	Uint16
14-32	Current Lim Ctr, Filter Time	27.0 ms	All set-ups	FALSE	-4	Uint16
<b>14-4* Energy Optimizing</b>						
14-40	VT Level	66 %	All set-ups	FALSE	0	Uint8
14-41	AEO Minimum Magnetization	ExpressionLimit	All set-ups	TRUE	0	Uint8
14-42	Minimum AEO Frequency	10 Hz	All set-ups	TRUE	0	Uint8
14-43	Motor Cos-Phi	ExpressionLimit	All set-ups	TRUE	-2	Uint16
<b>14-5* Environment</b>						
14-50	RFI 1	[1] On	1 set-up	FALSE	-	Uint8
14-52	Fan Control	[0] Auto	All set-ups	TRUE	-	Uint8
14-53	Fan Monitor	[1] Warning	All set-ups	TRUE	-	Uint8
14-55	Output Filter	[0] No Filter	1 set-up	FALSE	-	Uint8
14-59	Actual Number of Inverter Units	ExpressionLimit	1 set-up	FALSE	0	Uint8
<b>14-6* Auto Derate</b>						
14-60	Function at Overtemperature	[1] Derate	All set-ups	TRUE	-	Uint8
14-61	Function at Inverter Overload	[1] Derate	All set-ups	TRUE	-	Uint8
14-62	Inv. Overload Derate Current	95 %	All set-ups	TRUE	0	Uint16
<b>14-8* Options</b>						
14-80	Option Supplied by External 24VDC	[0] No	2 set-ups	FALSE	-	Uint8

### 8.3.14 Adj. Freq. Drive Information 15-\*\*-\*

Par. No. #	Parameter description	Default value	4-set-up	Change during operation	Conversion index	Type
<b>15-0* Operating Data</b>						
15-00	Operating Hours	0 h	All set-ups	FALSE	74	Uint32
15-01	Running Hours	0 h	All set-ups	FALSE	74	Uint32
15-02	kWh Counter	0 kWh	All set-ups	FALSE	75	Uint32
15-03	Power-ups	0 N/A	All set-ups	FALSE	0	Uint32
15-04	Over Temps	0 N/A	All set-ups	FALSE	0	Uint16
15-05	Over Volts	0 N/A	All set-ups	FALSE	0	Uint16
15-06	Reset kWh Counter	[0] Do not reset	All set-ups	TRUE	-	Uint8
15-07	Reset Running Hours Counter	[0] Do not reset	All set-ups	TRUE	-	Uint8
15-08	Number of Starts	0 N/A	All set-ups	FALSE	0	Uint32
<b>15-1* Data Log Settings</b>						
15-10	Logging Source	0	2 set-ups	TRUE	-	Uint16
15-11	Logging Interval	ExpressionLimit	2 set-ups	TRUE	-3	TimD
15-12	Trigger Event	[0] FALSE	1 set-up	TRUE	-	Uint8
15-13	Logging Mode	[0] Log always	2 set-ups	TRUE	-	Uint8
15-14	Samples Before Trigger	50 N/A	2 set-ups	TRUE	0	Uint8
<b>15-2* Historic Log</b>						
15-20	Historic Log: Event	0 N/A	All set-ups	FALSE	0	Uint8
15-21	Historic Log: Value	0 N/A	All set-ups	FALSE	0	Uint32
15-22	Historic Log: Time	0 ms	All set-ups	FALSE	-3	Uint32
15-23	Historic Log: Date and Time	ExpressionLimit	All set-ups	FALSE	0	TimeOfDay
<b>15-3* Alarm Log</b>						
15-30	Alarm Log: Error Code	0 N/A	All set-ups	FALSE	0	Uint16
15-31	Alarm Log: Value	0 N/A	All set-ups	FALSE	0	Uint16
15-32	Alarm Log: Time	0 s	All set-ups	FALSE	0	Uint32
15-33	Alarm Log: Date and Time	ExpressionLimit	All set-ups	FALSE	0	TimeOfDay
15-34	Alarm Log: Setpoint	0.000 ProcessCtrlUnit	All set-ups	FALSE	-3	Int32
15-35	Alarm Log: Feedback	0.000 ProcessCtrlUnit	All set-ups	FALSE	-3	Int32
15-36	Alarm Log: Current Demand	0 %	All set-ups	FALSE	0	Uint8
15-37	Alarm Log: Process Ctrl Unit	[0]	All set-ups	FALSE	-	Uint8
<b>15-4* Drive Identification</b>						
15-40	FC Type	0 N/A	All set-ups	FALSE	0	VisStr[6]
15-41	Power Section	0 N/A	All set-ups	FALSE	0	VisStr[20]
15-42	Voltage	0 N/A	All set-ups	FALSE	0	VisStr[20]
15-43	Software Version	0 N/A	All set-ups	FALSE	0	VisStr[5]
15-44	Ordered Typecode String	0 N/A	All set-ups	FALSE	0	VisStr[40]
15-45	Actual Typecode String	0 N/A	All set-ups	FALSE	0	VisStr[40]
15-46	Adj Freq Dr Ordering No.	0 N/A	All set-ups	FALSE	0	VisStr[8]
15-47	Power Card Ordering No.	0 N/A	All set-ups	FALSE	0	VisStr[8]
15-48	LCP ID Num.	0 N/A	All set-ups	FALSE	0	VisStr[20]
15-49	SW ID Control Card	0 N/A	All set-ups	FALSE	0	VisStr[20]
15-50	SW ID Power Card	0 N/A	All set-ups	FALSE	0	VisStr[20]
15-51	Adj Freq Dr Serial No.	0 N/A	All set-ups	FALSE	0	VisStr[10]
15-53	Power Card Serial Number	0 N/A	All set-ups	FALSE	0	VisStr[19]



Par. No. #	Parameter description	Default value	4-set-up	Change during operation	Conversion index	Type
<b>15-6* Option Ident</b>						
15-60	Option Mounted	0 N/A	All set-ups	FALSE	0	VisStr[30]
15-61	Option SW Version	0 N/A	All set-ups	FALSE	0	VisStr[20]
15-62	Option Ordering No	0 N/A	All set-ups	FALSE	0	VisStr[8]
15-63	Option Serial No	0 N/A	All set-ups	FALSE	0	VisStr[18]
15-70	Option in Slot A	0 N/A	All set-ups	FALSE	0	VisStr[30]
15-71	Slot A Option SW Version	0 N/A	All set-ups	FALSE	0	VisStr[20]
15-72	Option in Slot B	0 N/A	All set-ups	FALSE	0	VisStr[30]
15-73	Slot B Option SW Version	0 N/A	All set-ups	FALSE	0	VisStr[20]
15-74	Option in Slot C0	0 N/A	All set-ups	FALSE	0	VisStr[30]
15-75	Slot C0 Option SW Version	0 N/A	All set-ups	FALSE	0	VisStr[20]
15-76	Option in Slot C1	0 N/A	All set-ups	FALSE	0	VisStr[30]
15-77	Slot C1 Option SW Version	0 N/A	All set-ups	FALSE	0	VisStr[20]
<b>15-9* Parameter Info</b>						
15-92	Defined Parameters	0 N/A	All set-ups	FALSE	0	Uint16
15-93	Modified Parameters	0 N/A	All set-ups	FALSE	0	Uint16
15-98	Drive Identification	0 N/A	All set-ups	FALSE	0	VisStr[40]
15-99	Parameter Metadata	0 N/A	All set-ups	FALSE	0	Uint16

### 8.3.15 Data Readouts 16-\*\*-\*

Par. No. #	Parameter description	Default value	4-set-up	Change during operation	Conversion index	Type
<b>16-0* General Status</b>						
16-00	Control Word	0 N/A	All set-ups	TRUE	0	V2
16-01	Reference [Unit]	0.000 ReferenceFeedbackUnit	All set-ups	TRUE	-3	Int32
16-02	Reference %	0.0 %	All set-ups	TRUE	-1	Int16
16-03	Status Word	0 N/A	All set-ups	TRUE	0	V2
16-05	Main Actual Value [%]	0.00 %	All set-ups	TRUE	-2	N2
16-09	Custom Readout	0.00 CustomReadoutUnit	All set-ups	TRUE	-2	Int32
<b>16-1* Motor Status</b>						
16-10	Power [kW]	0.00 kW	All set-ups	TRUE	1	Int32
16-11	Power [hp]	0.00 hp	All set-ups	TRUE	-2	Int32
16-12	Motor voltage	0.0 V	All set-ups	TRUE	-1	Uint16
16-13	Frequency	0.0 Hz	All set-ups	TRUE	-1	Uint16
16-14	Motor Current	0.00 A	All set-ups	TRUE	-2	Int32
16-15	Frequency [%]	0.00 %	All set-ups	TRUE	-2	N2
16-16	Torque [Nm]	0.0 Nm	All set-ups	TRUE	-1	Int32
16-17	Speed [RPM]	0 RPM	All set-ups	TRUE	67	Int32
16-18	Motor Thermal	0 %	All set-ups	TRUE	0	Uint8
16-22	Torque [%]	0 %	All set-ups	TRUE	0	Int16
<b>16-3* Drive Status</b>						
16-30	DC Link Voltage	0 V	All set-ups	TRUE	0	Uint16
16-32	Brake Energy /s	0.000 kW	All set-ups	TRUE	0	Int32
16-33	Brake Energy /2 min	0.000 kW	All set-ups	TRUE	0	Int32
16-34	Heatsink Temp.	0 °C	All set-ups	TRUE	100	Uint8
16-35	Inverter Thermal	0 %	All set-ups	TRUE	0	Uint8
16-36	Inv. Nom. Current	ExpressionLimit	All set-ups	TRUE	-2	Uint32
16-37	Inv. Max. Current	ExpressionLimit	All set-ups	TRUE	-2	Uint32
16-38	SL Controller State	0 N/A	All set-ups	TRUE	0	Uint8
16-39	Control Card Temp.	0 °C	All set-ups	TRUE	100	Uint8
16-40	Logging Buffer Full	[0] No	All set-ups	TRUE	-	Uint8
<b>16-5* Ref. &amp; Feedb.</b>						
16-50	External Reference	0.0 N/A	All set-ups	TRUE	-1	Int16
16-52	Feedback [Unit]	0.000 ProcessCtrlUnit	All set-ups	TRUE	-3	Int32
16-53	Digi Pot Reference	0.00 N/A	All set-ups	TRUE	-2	Int16
16-54	Feedback 1 [Unit]	0.000 ProcessCtrlUnit	All set-ups	TRUE	-3	Int32
16-55	Feedback 2 [Unit]	0.000 ProcessCtrlUnit	All set-ups	TRUE	-3	Int32
16-56	Feedback 3 [Unit]	0.000 ProcessCtrlUnit	All set-ups	TRUE	-3	Int32
16-58	PID Output [%]	0.0 %	All set-ups	TRUE	-1	Int16
16-59	Adjusted Setpoint	0.000 ProcessCtrlUnit	All set-ups	TRUE	-3	Int32



Par. No. #	Parameter description	Default value	4-set-up	Change during operation	Conversion index	Type
<b>16-6* Inputs &amp; Outputs</b>						
16-60	Digital Input	0 N/A	All set-ups	TRUE	0	Uint16
16-61	Terminal 53 Switch Setting	[0] Current	All set-ups	TRUE	-	Uint8
16-62	Analog Input 53	0.000 N/A	All set-ups	TRUE	-3	Int32
16-63	Terminal 54 Switch Setting	[0] Current	All set-ups	TRUE	-	Uint8
16-64	Analog Input 54	0.000 N/A	All set-ups	TRUE	-3	Int32
16-65	Analog Output 42 [mA]	0.000 N/A	All set-ups	TRUE	-3	Int16
16-66	Digital Output [bin]	0 N/A	All set-ups	TRUE	0	Int16
16-67	Pulse Input #29 [Hz]	0 N/A	All set-ups	TRUE	0	Int32
16-68	Pulse Input #33 [Hz]	0 N/A	All set-ups	TRUE	0	Int32
16-69	Pulse Output #27 [Hz]	0 N/A	All set-ups	TRUE	0	Int32
16-70	Pulse Output #29 [Hz]	0 N/A	All set-ups	TRUE	0	Int32
16-71	Relay Output [bin]	0 N/A	All set-ups	TRUE	0	Uint16
16-72	Counter A	0 N/A	All set-ups	TRUE	0	Int32
16-73	Counter B	0 N/A	All set-ups	TRUE	0	Int32
16-75	Analog In X30/11	0.000 N/A	All set-ups	TRUE	-3	Int32
16-76	Analog In X30/12	0.000 N/A	All set-ups	TRUE	-3	Int32
16-77	Analog Out X30/8 [mA]	0.000 N/A	All set-ups	TRUE	-3	Int16
<b>16-8* Fieldbus &amp; FC Port</b>						
16-80	Fieldbus CTW 1	0 N/A	All set-ups	TRUE	0	V2
16-82	Fieldbus REF 1	0 N/A	All set-ups	TRUE	0	N2
16-84	Comm. Option Status	0 N/A	All set-ups	TRUE	0	V2
16-85	FC Port CTW 1	0 N/A	All set-ups	TRUE	0	V2
16-86	FC Port REF 1	0 N/A	All set-ups	TRUE	0	N2
<b>16-9* Diagnosis Readouts</b>						
16-90	Alarm Word	0 N/A	All set-ups	TRUE	0	Uint32
16-91	Alarm word 2	0 N/A	All set-ups	TRUE	0	Uint32
16-92	Warning Word	0 N/A	All set-ups	TRUE	0	Uint32
16-93	Warning word 2	0 N/A	All set-ups	TRUE	0	Uint32
16-94	Ext. Status Word	0 N/A	All set-ups	TRUE	0	Uint32
16-95	Ext. Status Word 2	0 N/A	All set-ups	TRUE	0	Uint32
16-96	Maintenance Word	0 N/A	All set-ups	TRUE	0	Uint32

### 8.3.16 Data Readouts 2 18-\*\*-\*

Par. No. #	Parameter description	Default value	4-set-up	Change during operation	Conversion index	Type
<b>18-0* Maintenance Log</b>						
18-00	Maintenance Log: Item	0 N/A	All set-ups	FALSE	0	Uint8
18-01	Maintenance Log: Action	0 N/A	All set-ups	FALSE	0	Uint8
18-02	Maintenance Log: Time	0 s	All set-ups	FALSE	0	Uint32
18-03	Maintenance Log: Date and Time	ExpressionLimit	All set-ups	FALSE	0	TimeOfDay
<b>18-3* Inputs &amp; Outputs</b>						
18-30	Analog Input X42/1	0.000 N/A	All set-ups	FALSE	-3	Int32
18-31	Analog Input X42/3	0.000 N/A	All set-ups	FALSE	-3	Int32
18-32	Analog Input X42/5	0.000 N/A	All set-ups	FALSE	-3	Int32
18-33	Analog Out X42/7 [V]	0.000 N/A	All set-ups	FALSE	-3	Int16
18-34	Analog Out X42/9 [V]	0.000 N/A	All set-ups	FALSE	-3	Int16
18-35	Analog Out X42/11 [V]	0.000 N/A	All set-ups	FALSE	-3	Int16



**8.3.17 Adj. Freq. Drive Closed-loop 20-\*\***

Par. No. #	Parameter description	Default value	4-set-up	Change during operation	Conversion index	Type
<b>20-0* Feedback</b>						
20-00	Feedback 1 Source	[2] Analog input 54	All set-ups	TRUE	-	Uint8
20-01	Feedback 1 Conversion	[0] Linear	All set-ups	FALSE	-	Uint8
20-02	Feedback 1 Source Unit	null	All set-ups	TRUE	-	Uint8
20-03	Feedback 2 Source	[0] No function	All set-ups	TRUE	-	Uint8
20-04	Feedback 2 Conversion	[0] Linear	All set-ups	FALSE	-	Uint8
20-05	Feedback 2 Source Unit	null	All set-ups	TRUE	-	Uint8
20-06	Feedback 3 Source	[0] No function	All set-ups	TRUE	-	Uint8
20-07	Feedback 3 Conversion	[0] Linear	All set-ups	FALSE	-	Uint8
20-08	Feedback 3 Source Unit	null	All set-ups	TRUE	-	Uint8
20-12	Reference/Feedback Unit	null	All set-ups	TRUE	-	Uint8
<b>20-2* Feedback/Setpoint</b>						
20-20	Feedback Function	[4] Maximum	All set-ups	TRUE	-	Uint8
20-21	Setpoint 1	0.000 ProcessCtrlUnit	All set-ups	TRUE	-3	Int32
20-22	Setpoint 2	0.000 ProcessCtrlUnit	All set-ups	TRUE	-3	Int32
20-23	Setpoint 3	0.000 ProcessCtrlUnit	All set-ups	TRUE	-3	Int32
<b>20-7* PID Auto-tuning</b>						
20-70	Closed-loop Type	[0] Auto	2 set-ups	TRUE	-	Uint8
20-71	PID Performance	[0] Normal	2 set-ups	TRUE	-	Uint8
20-72	PID Output Change	0.10 N/A	2 set-ups	TRUE	-2	Uint16
20-73	Minimum Feedback Level	-999999.000 ProcessCtrlUnit	2 set-ups	TRUE	-3	Int32
20-74	Maximum Feedback Level	999999.000 ProcessCtrlUnit	2 set-ups	TRUE	-3	Int32
20-79	PID Auto-tuning	[0] Disabled	All set-ups	TRUE	-	Uint8
<b>20-8* PID Basic Settings</b>						
20-81	PID Normal/ Inverse Control	[0] Normal	All set-ups	TRUE	-	Uint8
20-82	PID Start Speed [RPM]	ExpressionLimit	All set-ups	TRUE	67	Uint16
20-83	PID Start Speed [Hz]	ExpressionLimit	All set-ups	TRUE	-1	Uint16
20-84	On Reference Bandwidth	5 %	All set-ups	TRUE	0	Uint8
<b>20-9* PID Controller</b>						
20-91	PID Anti Windup	[1] On	All set-ups	TRUE	-	Uint8
20-93	PID Proportional Gain	2.00 N/A	All set-ups	TRUE	-2	Uint16
20-94	PID Integral Time	8.00 s	All set-ups	TRUE	-2	Uint32
20-95	PID Differentiation Time	0.00 s	All set-ups	TRUE	-2	Uint16
20-96	PID Diff. Gain Limit	5.0 N/A	All set-ups	TRUE	-1	Uint16

**8.3.18 Ext. Closed-loop 21-\*\*-\***

Par. No. #	Parameter description	Default value	4-set-up	Change during operation	Conversion index	Type
<b>21-0* Ext. CL Autotuning</b>						
21-00	Closed-loop Type	[0] Auto	2 set-ups	TRUE	-	Uint8
21-01	PID Performance	[0] Normal	2 set-ups	TRUE	-	Uint8
21-02	PID Output Change	0.10 N/A	2 set-ups	TRUE	-2	Uint16
21-03	Minimum Feedback Level	-999999.000 N/A	2 set-ups	TRUE	-3	Int32
21-04	Maximum Feedback Level	999999.000 N/A	2 set-ups	TRUE	-3	Int32
21-09	PID Auto Tuning	[0] Disabled	All set-ups	TRUE	-	Uint8
<b>21-1* Ext. CL 1 Ref./Fb.</b>						
21-10	Ext. 1 Ref./Feedback Unit	[0]	All set-ups	TRUE	-	Uint8
21-11	Ext. 1 Minimum Reference	0.000 ExtPID1Unit	All set-ups	TRUE	-3	Int32
21-12	Ext. 1 Maximum Reference	100.000 ExtPID1Unit	All set-ups	TRUE	-3	Int32
21-13	Ext. 1 Reference Source	[0] No function	All set-ups	TRUE	-	Uint8
21-14	Ext. 1 Feedback Source	[0] No function	All set-ups	TRUE	-	Uint8
21-15	Ext. 1 Setpoint	0.000 ExtPID1Unit	All set-ups	TRUE	-3	Int32
21-17	Ext. 1 Reference [Unit]	0.000 ExtPID1Unit	All set-ups	TRUE	-3	Int32
21-18	Ext. 1 Feedback [Unit]	0.000 ExtPID1Unit	All set-ups	TRUE	-3	Int32
21-19	Ext. 1 Output [%]	0 %	All set-ups	TRUE	0	Int32
<b>21-2* Ext. CL 1 PID</b>						
21-20	Ext. 1 Normal/Inverse Control	[0] Normal	All set-ups	TRUE	-	Uint8
21-21	Ext. 1 Proportional Gain	0.50 N/A	All set-ups	TRUE	-2	Uint16
21-22	Ext. 1 Integral Time	20.00 s	All set-ups	TRUE	-2	Uint32
21-23	Ext. 1 Differentiation Time	0.00 s	All set-ups	TRUE	-2	Uint16
21-24	Ext. 1 Dif. Gain Limit	5.0 N/A	All set-ups	TRUE	-1	Uint16
<b>21-3* Ext. CL 2 Ref./Fb.</b>						
21-30	Ext. 2 Ref./Feedback Unit	[0]	All set-ups	TRUE	-	Uint8
21-31	Ext. 2 Minimum Reference	0.000 ExtPID2Unit	All set-ups	TRUE	-3	Int32
21-32	Ext. 2 Maximum Reference	100.000 ExtPID2Unit	All set-ups	TRUE	-3	Int32
21-33	Ext. 2 Reference Source	[0] No function	All set-ups	TRUE	-	Uint8
21-34	Ext. 2 Feedback Source	[0] No function	All set-ups	TRUE	-	Uint8
21-35	Ext. 2 Setpoint	0.000 ExtPID2Unit	All set-ups	TRUE	-3	Int32
21-37	Ext. 2 Reference [Unit]	0.000 ExtPID2Unit	All set-ups	TRUE	-3	Int32
21-38	Ext. 2 Feedback [Unit]	0.000 ExtPID2Unit	All set-ups	TRUE	-3	Int32
21-39	Ext. 2 Output [%]	0 %	All set-ups	TRUE	0	Int32
<b>21-4* Ext. CL 2 PID</b>						
21-40	Ext. 2 Normal/Inverse Control	[0] Normal	All set-ups	TRUE	-	Uint8
21-41	Ext. 2 Proportional Gain	0.50 N/A	All set-ups	TRUE	-2	Uint16
21-42	Ext. 2 Integral Time	20.00 s	All set-ups	TRUE	-2	Uint32
21-43	Ext. 2 Differentiation Time	0.00 s	All set-ups	TRUE	-2	Uint16
21-44	Ext. 2 Dif. Gain Limit	5.0 N/A	All set-ups	TRUE	-1	Uint16





Par. No. #	Parameter description	Default value	4-set-up	Change during operation	Conversion index	Type
<b>21-5*</b>	<b>Ext. CL 3 Ref./Fb.</b>					
21-50	Ext. 3 Ref./Feedback Unit	[0]	All set-ups	TRUE	-	Uint8
21-51	Ext. 3 Minimum Reference	0.000 ExtPID3Unit	All set-ups	TRUE	-3	Int32
21-52	Ext. 3 Maximum Reference	100.000 ExtPID3Unit	All set-ups	TRUE	-3	Int32
21-53	Ext. 3 Reference Source	[0] No function	All set-ups	TRUE	-	Uint8
21-54	Ext. 3 Feedback Source	[0] No function	All set-ups	TRUE	-	Uint8
21-55	Ext. 3 Setpoint	0.000 ExtPID3Unit	All set-ups	TRUE	-3	Int32
21-57	Ext. 3 Reference [Unit]	0.000 ExtPID3Unit	All set-ups	TRUE	-3	Int32
21-58	Ext. 3 Feedback [Unit]	0.000 ExtPID3Unit	All set-ups	TRUE	-3	Int32
21-59	Ext. 3 Output [%]	0 %	All set-ups	TRUE	0	Int32
<b>21-6*</b>	<b>Ext. CL 3 PID</b>					
21-60	Ext. 3 Normal/Inverse Control	[0] Normal	All set-ups	TRUE	-	Uint8
21-61	Ext. 3 Proportional Gain	0.50 N/A	All set-ups	TRUE	-2	Uint16
21-62	Ext. 3 Integral Time	20.00 s	All set-ups	TRUE	-2	Uint32
21-63	Ext. 3 Differentiation Time	0.00 s	All set-ups	TRUE	-2	Uint16
21-64	Ext. 3 Dif. Gain Limit	5.0 N/A	All set-ups	TRUE	-1	Uint16

### 8.3.19 Application Functions 22-\*\*

Par. No. #	Parameter description	Default value	4-set-up	Change during operation	Conversion index	Type
<b>22-0* Miscellaneous</b>						
22-00	External Interlock Delay	0 s	All set-ups	TRUE	0	Uint16
<b>22-2* No-Flow Detection</b>						
22-20	Low Power Auto Set-up	[0] OFF	All set-ups	FALSE	-	Uint8
22-21	Low Power Detection	[0] Disabled	All set-ups	TRUE	-	Uint8
22-22	Low Speed Detection	[0] Disabled	All set-ups	TRUE	-	Uint8
22-23	No-Flow Function	[0] OFF	All set-ups	TRUE	-	Uint8
22-24	No-Flow Delay	10 s	All set-ups	TRUE	0	Uint16
22-26	Dry Pump Function	[0] OFF	All set-ups	TRUE	-	Uint8
22-27	Dry Pump Delay	10 s	All set-ups	TRUE	0	Uint16
22-28	No-Flow Low Speed [RPM]	ExpressionLimit	All set-ups	TRUE	67	Uint16
22-29	No-Flow Low Speed [Hz]	ExpressionLimit	All set-ups	TRUE	-1	Uint16
<b>22-3* No-Flow Power Tuning</b>						
22-30	No-Flow Power	0.00 kW	All set-ups	TRUE	1	Uint32
22-31	Power Correction Factor	100 %	All set-ups	TRUE	0	Uint16
22-32	Low Speed [RPM]	ExpressionLimit	All set-ups	TRUE	67	Uint16
22-33	Low Speed [Hz]	ExpressionLimit	All set-ups	TRUE	-1	Uint16
22-34	Low Speed Power [kW]	ExpressionLimit	All set-ups	TRUE	1	Uint32
22-35	Low Speed Power [HP]	ExpressionLimit	All set-ups	TRUE	-2	Uint32
22-36	High Speed [RPM]	ExpressionLimit	All set-ups	TRUE	67	Uint16
22-37	High Speed [Hz]	ExpressionLimit	All set-ups	TRUE	-1	Uint16
22-38	High Speed Power [kW]	ExpressionLimit	All set-ups	TRUE	1	Uint32
22-39	High Speed Power [HP]	ExpressionLimit	All set-ups	TRUE	-2	Uint32
<b>22-4* Sleep Mode</b>						
22-40	Minimum Run Time	60 s	All set-ups	TRUE	0	Uint16
22-41	Minimum Sleep Time	30 s	All set-ups	TRUE	0	Uint16
22-42	Wake-up Speed [RPM]	ExpressionLimit	All set-ups	TRUE	67	Uint16
22-43	Wake-up Speed [Hz]	ExpressionLimit	All set-ups	TRUE	-1	Uint16
22-44	Wake-up Ref./FB Difference	10 %	All set-ups	TRUE	0	Int8
22-45	Setpoint Boost	0 %	All set-ups	TRUE	0	Int8
22-46	Maximum Boost Time	60 s	All set-ups	TRUE	0	Uint16
<b>22-5* End of Curve</b>						
22-50	End of Curve Function	[0] OFF	All set-ups	TRUE	-	Uint8
22-51	End of Curve Delay	10 s	All set-ups	TRUE	0	Uint16
<b>22-6* Broken Belt Detection</b>						
22-60	Broken Belt Function	[0] OFF	All set-ups	TRUE	-	Uint8
22-61	Broken Belt Torque	10 %	All set-ups	TRUE	0	Uint8
22-62	Broken Belt Delay	10 s	All set-ups	TRUE	0	Uint16
<b>22-7* Short Cycle Protection</b>						
22-75	Short Cycle Protection	[0] Disabled	All set-ups	TRUE	-	Uint8
22-76	Interval between Starts	start_to_start_min_on_time (P2277)	All set-ups	TRUE	0	Uint16
22-77	Minimum Run Time	0 s	All set-ups	TRUE	0	Uint16



Par. No. #	Parameter description	Default value	4-set-up	Change during operation	Conversion index	Type
<b>22-8*</b>	<b>Flow Compensation</b>					
22-80	Flow Compensation	[0] Disabled	All set-ups	TRUE	-	Uint8
22-81	Square-linear Curve Approximation	100 %	All set-ups	TRUE	0	Uint8
22-82	Work Point Calculation	[0] Disabled	All set-ups	TRUE	-	Uint8
22-83	Speed at No-Flow [RPM]	ExpressionLimit	All set-ups	TRUE	67	Uint16
22-84	Speed at No-Flow [Hz]	ExpressionLimit	All set-ups	TRUE	-1	Uint16
22-85	Speed at Design Point [RPM]	ExpressionLimit	All set-ups	TRUE	67	Uint16
22-86	Speed at Design Point [Hz]	ExpressionLimit	All set-ups	TRUE	-1	Uint16
22-87	Pressure at No-Flow Speed	0.000 N/A	All set-ups	TRUE	-3	Int32
22-88	Pressure at Rated Speed	999999.999 N/A	All set-ups	TRUE	-3	Int32
22-89	Flow at Design Point	0.000 N/A	All set-ups	TRUE	-3	Int32
22-90	Flow at Rated Speed	0.000 N/A	All set-ups	TRUE	-3	Int32

### 8.3.20 Timed Actions 23-\*\*-\*\*

Par. No. #	Parameter description	Default value	4-set-up	Change during operation	Conversion index	Type
<b>23-0* Timed Actions</b>						
23-00	ON Time	ExpressionLimit	2 set-ups	TRUE	0	TimeOfDay- WoDate
23-01	ON Action	[0] DISABLED	2 set-ups	TRUE	-	Uint8
23-02	OFF Time	ExpressionLimit	2 set-ups	TRUE	0	TimeOfDay- WoDate
23-03	OFF Action	[0] DISABLED	2 set-ups	TRUE	-	Uint8
23-04	Occurrence	[0] All days	2 set-ups	TRUE	-	Uint8
<b>23-1* Maintenance</b>						
23-10	Maintenance Item	[1] Motor bearings	1 set-up	TRUE	-	Uint8
23-11	Maintenance Action	[1] Lubricate	1 set-up	TRUE	-	Uint8
23-12	Maintenance Time Base	[0] Disabled	1 set-up	TRUE	-	Uint8
23-13	Maintenance Time Interval	1 h	1 set-up	TRUE	74	Uint32
23-14	Maintenance Date and Time	ExpressionLimit	1 set-up	TRUE	0	TimeOfDay
<b>23-1* Maintenance Reset</b>						
23-15	Reset Maintenance Word	[0] Do not reset	All set-ups	TRUE	-	Uint8
23-16	Maintenance Text	0 N/A	1 set-up	TRUE	0	VisStr[20]
<b>23-5* Energy Log</b>						
23-50	Energy Log Resolution	[5] Last 24 Hours	2 set-ups	TRUE	-	Uint8
23-51	Period Start	ExpressionLimit	2 set-ups	TRUE	0	TimeOfDay
23-53	Energy Log	0 N/A	All set-ups	TRUE	0	Uint32
23-54	Reset Energy Log	[0] Do not reset	All set-ups	TRUE	-	Uint8
<b>23-6* Trending</b>						
23-60	Trend Variable	[0] Power [kW]	2 set-ups	TRUE	-	Uint8
23-61	Continuous Bin Data	0 N/A	All set-ups	TRUE	0	Uint32
23-62	Timed Bin Data	0 N/A	All set-ups	TRUE	0	Uint32
23-63	Timed Period Start	ExpressionLimit	2 set-ups	TRUE	0	TimeOfDay
23-64	Timed Period Stop	ExpressionLimit	2 set-ups	TRUE	0	TimeOfDay
23-65	Minimum Bin Value	ExpressionLimit	2 set-ups	TRUE	0	Uint8
23-66	Reset Continuous Bin Data	[0] Do not reset	All set-ups	TRUE	-	Uint8
23-67	Reset Timed Bin Data	[0] Do not reset	All set-ups	TRUE	-	Uint8
<b>23-8* Payback Counter</b>						
23-80	Power Reference Factor	100 %	2 set-ups	TRUE	0	Uint8
23-81	Energy Cost	1.00 N/A	2 set-ups	TRUE	-2	Uint32
23-82	Investment	0 N/A	2 set-ups	TRUE	0	Uint32
23-83	Energy Savings	0 kWh	All set-ups	TRUE	75	Int32
23-84	Cost Savings	0 N/A	All set-ups	TRUE	0	Int32



**8.3.21 Cascade Controller 25-\*\***

Par. No. #	Parameter description	Default value	4-set-up	Change during operation	Conversion index	Type
<b>25-0* System Settings</b>						
25-00	Cascade Controller	null	2 set-ups	FALSE	-	Uint8
25-02	Motor Start	[0] Direct on Line	2 set-ups	FALSE	-	Uint8
25-04	Pump Cycling	null	All set-ups	TRUE	-	Uint8
25-05	Fixed Lead Pump	null	2 set-ups	FALSE	-	Uint8
25-06	Number Of Pumps	2 N/A	2 set-ups	FALSE	0	Uint8
<b>25-2* Bandwidth Settings</b>						
25-20	Staging Bandwidth	ExpressionLimit	All set-ups	TRUE	0	Uint8
25-21	Override Bandwidth	100 %	All set-ups	TRUE	0	Uint8
25-22	Fixed Speed Bandwidth	casco_staging_bandwidth (P2520)	All set-ups	TRUE	0	Uint8
25-23	SBW Staging Delay	15 s	All set-ups	TRUE	0	Uint16
25-24	SBW De-staging Delay	15 s	All set-ups	TRUE	0	Uint16
25-25	OBW Time	10 s	All set-ups	TRUE	0	Uint16
25-26	Destage At No-Flow	[0] Disabled	All set-ups	TRUE	-	Uint8
25-27	Stage Function	null	All set-ups	TRUE	-	Uint8
25-28	Stage Function Time	15 s	All set-ups	TRUE	0	Uint16
25-29	Destage Function	null	All set-ups	TRUE	-	Uint8
25-30	Destage Function Time	15 s	All set-ups	TRUE	0	Uint16
<b>25-4* Staging Settings</b>						
25-40	Ramp-down Delay	10.0 s	All set-ups	TRUE	-1	Uint16
25-41	Ramp-up Delay	2.0 s	All set-ups	TRUE	-1	Uint16
25-42	Staging Threshold	ExpressionLimit	All set-ups	TRUE	0	Uint8
25-43	De-staging Threshold	ExpressionLimit	All set-ups	TRUE	0	Uint8
25-44	Staging Speed [RPM]	0 RPM	All set-ups	TRUE	67	Uint16
25-45	Staging Speed [Hz]	0.0 Hz	All set-ups	TRUE	-1	Uint16
25-46	De-staging Speed [RPM]	0 RPM	All set-ups	TRUE	67	Uint16
25-47	De-staging Speed [Hz]	0.0 Hz	All set-ups	TRUE	-1	Uint16
<b>25-5* Alternation Settings</b>						
25-50	Lead Pump Alternation	null	All set-ups	TRUE	-	Uint8
25-51	Alternation Event	[0] External	All set-ups	TRUE	-	Uint8
25-52	Alternation Time Interval	24 h	All set-ups	TRUE	74	Uint16
25-53	Alternation Timer Value	0 N/A	All set-ups	TRUE	0	VisStr[7] TimeOfDay-
25-54	Alternation Predefined Time	ExpressionLimit	All set-ups	TRUE	0	WoDate
25-55	Alternate if Load < 50%	[1] Enabled	All set-ups	TRUE	-	Uint8
25-56	Staging Mode at Alternation	[0] Slow	All set-ups	TRUE	-	Uint8
25-58	Run Next Pump Delay	0.1 s	All set-ups	TRUE	-1	Uint16
25-59	Run-on Line Delay	0.5 s	All set-ups	TRUE	-1	Uint16

Par. No. #	Parameter description	Default value	4-set-up	Change during operation	Conversion index	Type
<b>25-8* Status</b>						
25-80	Cascade Status	0 N/A	All set-ups	TRUE	0	VisStr[25]
25-81	Pump Status	0 N/A	All set-ups	TRUE	0	VisStr[25]
25-82	Lead Pump	0 N/A	All set-ups	TRUE	0	Uint8
25-83	Relay Status	0 N/A	All set-ups	TRUE	0	VisStr[4]
25-84	Pump ON Time	0 h	All set-ups	TRUE	74	Uint32
25-85	Relay ON Time	0 h	All set-ups	TRUE	74	Uint32
25-86	Reset Relay Counters	[0] Do not reset	All set-ups	TRUE	-	Uint8
<b>25-9* Service</b>						
25-90	Pump Interlock	[0] Off	All set-ups	TRUE	-	Uint8
25-91	Manual Alternation	0 N/A	All set-ups	TRUE	0	Uint8



**8.3.22 Analog I/O Option MCB 109 26-\*\*\***

Par. No. #	Parameter description	Default value	4-set-up	Change during operation	Conversion index	Type
<b>26-0* Analog I/O Mode</b>						
26-00	Terminal X42/1 Mode	[1] Voltage	All set-ups	TRUE	-	Uint8
26-01	Terminal X42/3 Mode	[1] Voltage	All set-ups	TRUE	-	Uint8
26-02	Terminal X42/5 Mode	[1] Voltage	All set-ups	TRUE	-	Uint8
<b>26-1* Analog Input X42/1</b>						
26-10	Terminal X42/1 Low Voltage	0.07 V	All set-ups	TRUE	-2	Int16
26-11	Terminal X42/1 High Voltage	10.00 V	All set-ups	TRUE	-2	Int16
26-14	Term. X42/1 Low Ref./Feedb. Value	0.000 N/A	All set-ups	TRUE	-3	Int32
26-15	Term. X42/1 High Ref./Feedb. Value	100.000 N/A	All set-ups	TRUE	-3	Int32
26-16	Term. X42/1 Filter Time Constant	0.001 s	All set-ups	TRUE	-3	Uint16
26-17	Term. X42/1 Live Zero	[1] Enabled	All set-ups	TRUE	-	Uint8
<b>26-2* Analog Input X42/3</b>						
26-20	Terminal X42/3 Low Voltage	0.07 V	All set-ups	TRUE	-2	Int16
26-21	Terminal X42/3 High Voltage	10.00 V	All set-ups	TRUE	-2	Int16
26-24	Term. X42/3 Low Ref./Feedb. Value	0.000 N/A	All set-ups	TRUE	-3	Int32
26-25	Term. X42/3 High Ref./Feedb. Value	100.000 N/A	All set-ups	TRUE	-3	Int32
26-26	Term. X42/3 Filter Time Constant	0.001 s	All set-ups	TRUE	-3	Uint16
26-27	Term. X42/3 Live Zero	[1] Enabled	All set-ups	TRUE	-	Uint8
<b>26-3* Analog Input X42/5</b>						
26-30	Terminal X42/5 Low Voltage	0.07 V	All set-ups	TRUE	-2	Int16
26-31	Terminal X42/5 High Voltage	10.00 V	All set-ups	TRUE	-2	Int16
26-34	Term. X42/5 Low Ref./Feedb. Value	0.000 N/A	All set-ups	TRUE	-3	Int32
26-35	Term. X42/5 High Ref./Feedb. Value	100.000 N/A	All set-ups	TRUE	-3	Int32
26-36	Term. X42/5 Filter Time Constant	0.001 s	All set-ups	TRUE	-3	Uint16
26-37	Term. X42/5 Live Zero	[1] Enabled	All set-ups	TRUE	-	Uint8
<b>26-4* Analog Out X42/7</b>						
26-40	Terminal X42/7 Output	[0] No operation	All set-ups	TRUE	-	Uint8
26-41	Terminal X42/7 Min. Scale	0.00 %	All set-ups	TRUE	-2	Int16
26-42	Terminal X42/7 Max. Scale	100.00 %	All set-ups	TRUE	-2	Int16
26-43	Terminal X42/7 Bus Control	0.00 %	All set-ups	TRUE	-2	N2
26-44	Terminal X42/7 Timeout Preset	0.00 %	1 set-up	TRUE	-2	Uint16
<b>26-5* Analog Out X42/9</b>						
26-50	Terminal X42/9 Output	[0] No operation	All set-ups	TRUE	-	Uint8
26-51	Terminal X42/9 Min. Scale	0.00 %	All set-ups	TRUE	-2	Int16
26-52	Terminal X42/9 Max. Scale	100.00 %	All set-ups	TRUE	-2	Int16
26-53	Terminal X42/9 Bus Control	0.00 %	All set-ups	TRUE	-2	N2
26-54	Terminal X42/9 Timeout Preset	0.00 %	1 set-up	TRUE	-2	Uint16
<b>26-6* Analog Out X42/11</b>						
26-60	Terminal X42/11 Output	[0] No operation	All set-ups	TRUE	-	Uint8
26-61	Terminal X42/11 Min. Scale	0.00 %	All set-ups	TRUE	-2	Int16
26-62	Terminal X42/11 Max. Scale	100.00 %	All set-ups	TRUE	-2	Int16
26-63	Terminal X42/11 Bus Control	0.00 %	All set-ups	TRUE	-2	N2
26-64	Terminal X42/11 Timeout Preset	0.00 %	1 set-up	TRUE	-2	Uint16

### 8.3.23 Cascade CTL Option 27-\*\*-\*\*

Par. No. #	Parameter description	Default value	4-set-up	Change during operation	Conversion index	Type
<b>27-0* Control &amp; Status</b>						
27-01	Pump Status	[0] Ready	All set-ups	TRUE	-	Uint8
27-02	Manual Pump Control	[0] No Operation	2 set-ups	TRUE	-	Uint8
27-03	Current Runtime Hours	0 h	All set-ups	TRUE	74	Uint32
27-04	Pump Total Lifetime Hours	0 h	All set-ups	TRUE	74	Uint32
<b>27-1* Configuration</b>						
27-10	Cascade Controller	[0] Disabled	2 set-ups	FALSE	-	Uint8
27-11	Number Of Drives	1 N/A	2 set-ups	FALSE	0	Uint8
27-12	Number Of Pumps	ExpressionLimit	2 set-ups	FALSE	0	Uint8
27-14	Pump Capacity	100 %	2 set-ups	FALSE	0	Uint16
27-16	Runtime Balancing	[0] Balanced Priority 1	2 set-ups	TRUE	-	Uint8
27-17	Motor Starters	[0] Direct Online	2 set-ups	FALSE	-	Uint8
27-18	Spin Time for Unused Pumps	ExpressionLimit	All set-ups	TRUE	0	Uint16
27-19	Reset Current Runtime Hours	[0] Do not reset	All set-ups	TRUE	-	Uint8
<b>27-2* Bandwidth Settings</b>						
27-20	Normal Operating Range	ExpressionLimit	All set-ups	TRUE	0	Uint8
27-21	Override Limit	100 %	All set-ups	TRUE	0	Uint8
27-22	Fixed Speed Only Operating Range	ExpressionLimit	All set-ups	TRUE	0	Uint8
27-23	Staging Delay	15 s	All set-ups	TRUE	0	Uint16
27-24	Destaging Delay	15 s	All set-ups	TRUE	0	Uint16
27-25	Override Hold Time	10 s	All set-ups	TRUE	0	Uint16
27-27	Min. Speed Destage Delay	ExpressionLimit	All set-ups	TRUE	0	Uint16
<b>27-3* Staging Speed</b>						
27-30	Auto Tune Staging Speeds	[1] Enabled	All set-ups	TRUE	-	Uint8
27-31	Stage On Speed [RPM]	ExpressionLimit	All set-ups	TRUE	67	Uint16
27-32	Stage On Speed [Hz]	ExpressionLimit	All set-ups	TRUE	-1	Uint16
27-33	Stage Off Speed [RPM]	ExpressionLimit	All set-ups	TRUE	67	Uint16
27-34	Stage Off Speed [Hz]	ExpressionLimit	All set-ups	TRUE	-1	Uint16
<b>27-4* Staging Settings</b>						
27-40	Auto Tune Staging Settings	[0] Disabled	All set-ups	TRUE	-	Uint8
27-41	Ramp Down Delay	10.0 s	All set-ups	TRUE	-1	Uint16
27-42	Ramp Up Delay	2.0 s	All set-ups	TRUE	-1	Uint16
27-43	Staging Threshold	ExpressionLimit	All set-ups	TRUE	0	Uint8
27-44	Destaging Threshold	ExpressionLimit	All set-ups	TRUE	0	Uint8
27-45	Staging Speed [RPM]	0 RPM	All set-ups	TRUE	67	Uint16
27-46	Staging Speed [Hz]	0.0 Hz	All set-ups	TRUE	-1	Uint16
27-47	Destaging Speed [RPM]	0 RPM	All set-ups	TRUE	67	Uint16
27-48	Destaging Speed [Hz]	0.0 Hz	All set-ups	TRUE	-1	Uint16





Par. No. #	Parameter description	Default value	4-set-up	Change during operation	Conversion index	Type
<b>27-5* Alternate Settings</b>						
27-50	Automatic Alternation	[0] Disabled	All set-ups	FALSE	-	Uint8
27-51	Alternation Event	null	All set-ups	TRUE	-	Uint8
27-52	Alternation Time Interval	0 min	All set-ups	TRUE	70	Uint16
27-53	Alternation Timer Value	0 min	All set-ups	TRUE	70	Uint16
27-54	Alternation At Time of Day	[0] Disabled	All set-ups	TRUE	-	Uint8
27-55	Alternation Predefined Time	ExpressionLimit	All set-ups	TRUE	0	TimeOfDay-
27-56	Alternate Capacity is <	0 %	All set-ups	TRUE	0	Uint8
27-58	Run Next Pump Delay	0.1 s	All set-ups	TRUE	-1	Uint16
<b>27-6* Digital Inputs</b>						
27-60	Terminal X66/1 Digital Input	[0] No operation	All set-ups	TRUE	-	Uint8
27-61	Terminal X66/3 Digital Input	[0] No operation	All set-ups	TRUE	-	Uint8
27-62	Terminal X66/5 Digital Input	[0] No operation	All set-ups	TRUE	-	Uint8
27-63	Terminal X66/7 Digital Input	[0] No operation	All set-ups	TRUE	-	Uint8
27-64	Terminal X66/9 Digital Input	[0] No operation	All set-ups	TRUE	-	Uint8
27-65	Terminal X66/11 Digital Input	[0] No operation	All set-ups	TRUE	-	Uint8
27-66	Terminal X66/13 Digital Input	[0] No operation	All set-ups	TRUE	-	Uint8
<b>27-7* Connections</b>						
27-70	Relay	[0] Standard Relay	2 set-ups	FALSE	-	Uint8
<b>27-9* Readouts</b>						
27-91	Cascade Reference	0.0 %	All set-ups	TRUE	-1	Int16
27-92	% Of Total Capacity	0 %	All set-ups	TRUE	0	Uint16
27-93	Cascade Option Status	[0] Disabled	All set-ups	TRUE	-	Uint8
27-94	Cascade System Status	0 N/A	All set-ups	TRUE	0	VisStr[25]

### 8.3.24 Water Application Functions 29-\*\*-\*\*

Par. No. #	Parameter description	Default value	4-set-up	Change during operation	Conversion index	Type
<b>29-0* Pipe Fill</b>						
29-00	Pipe Fill Enable	[0] Disabled	2 set-ups	FALSE	-	Uint8
29-01	Pipe Fill Speed [RPM]	ExpressionLimit	All set-ups	TRUE	67	Uint16
29-02	Pipe Fill Speed [Hz]	ExpressionLimit	All set-ups	TRUE	-1	Uint16
29-03	Pipe Fill Time	0.00 s	All set-ups	TRUE	-2	Uint32
29-04	Pipe Fill Rate	0.001 ProcessCtrlUnit	All set-ups	TRUE	-3	Int32
29-05	Filled Setpoint	0.000 ProcessCtrlUnit	All set-ups	TRUE	-3	Int32



**8.3.25 Bypass Option 31-\*\*-\***

Par. No. #	Parameter description	Default value	4-set-up	Change during operation	Conversion index	Type
31-00	Bypass Mode	[0] Drive	All set-ups	TRUE	-	Uint8
31-01	Bypass Start Time Delay	30 s	All set-ups	TRUE	0	Uint16
31-02	Bypass Trip Time Delay	0 s	All set-ups	TRUE	0	Uint16
31-03	Test Mode Activation	[0] Disabled	All set-ups	TRUE	-	Uint8
31-10	Bypass Status Word	0 N/A	All set-ups	FALSE	0	V2
31-11	Bypass Running Hours	0 h	All set-ups	FALSE	74	Uint32
31-19	Remote Bypass Activation	[0] Disabled	2 set-ups	TRUE	-	Uint8

## 9 Troubleshooting

### 9.1 Alarms and Warnings

A warning or an alarm is signaled by the relevant LED on the front of the adjustable frequency drive and indicated by a code on the display.

A warning remains active until its cause is no longer present. Under certain circumstances operation of the motor may still be continued. Warning messages may be critical, but are not necessarily so.

In the event of an alarm, the adjustable frequency drive will have tripped. Alarms must be reset to restart operation once their cause has been rectified.

**This may be done in four ways:**

1. By using the [RESET] control button on the LCP control panel.
2. Via a digital input with the "Reset" function.
3. Via serial communication/optional serial communication bus.
4. By resetting automatically using the [Auto Reset] function, which is a default setting for VLT AQUA Drive, see par. 14-20 *Reset Mode* in **VLT AQUA Drive Programming Guide**



**NOTE!**

After a manual reset using the [RESET] button on the LCP, the [AUTO ON] or [HAND ON] button must be pressed to restart the motor.

If an alarm cannot be reset, the reason may be that its cause has not been rectified, or the alarm is trip-locked (see also table on following page).

Alarms that are trip-locked offer additional protection, means that the line power supply must be switched off before the alarm can be reset. After being switched back on, the adjustable frequency drive is no longer blocked and may be reset as described above, once the cause has been rectified.

Alarms that are not trip-locked can also be reset using the automatic reset function in par. 14-20 *Reset Mode* (Warning: automatic wake-up is possible!)

If a warning and alarm is marked against a code in the table on the following page, this means that either a warning occurs before an alarm, or it can be specified whether it is a warning or an alarm that is to be displayed for a given fault.

This is possible, for instance, in par. 1-90 *Motor Thermal Protection*. After an alarm or trip, the motor carries on coasting, and the alarm and warning flash on the adjustable frequency drive. Once the problem has been rectified, only the alarm continues flashing.

No.	Description	Warning	Alarm/Trip	Alarm/Trip Lock	Parameter Reference
1	10 Volts low	X			
2	Live zero error	(X)	(X)		6-01
3	No motor	(X)			1-80
4	Line phase loss	(X)	(X)	(X)	14-12
5	DC link voltage high	X			
6	DC link voltage low	X			
7	DC overvolt	X	X		
8	DC undervolt	X	X		
9	Inverter overloaded	X	X		
10	Motor ETR overtemperature	(X)	(X)		1-90
11	Motor thermistor overtemperature	(X)	(X)		1-90
12	Torque limit	X	X		
13	Overcurrent	X	X	X	
14	Ground fault	X	X	X	
15	Hardware mismatch		X	X	
16	Short Circuit		X	X	
17	Control word timeout	(X)	(X)		8-04
23	Internal Fan Fault	X			
24	External Fan Fault	X			14-53
25	Brake resistor short-circuited	X			
26	Brake resistor power limit	(X)	(X)		2-13
27	Brake chopper short-circuited	X	X		
28	Brake check	(X)	(X)		2-15
29	Drive overtemperature	X	X	X	
30	Motor phase U missing	(X)	(X)	(X)	4-58
31	Motor phase V missing	(X)	(X)	(X)	4-58
32	Motor phase W missing	(X)	(X)	(X)	4-58
33	Soft-charge fault		X	X	
34	Serial communication fault	X	X		
35	Out of frequency ranges	X	X		
36	Line failure	X	X		
37	Phase Imbalance	X	X		
39	Heatsink sensor		X	X	
40	Overload of Digital Output Terminal 27	(X)			5-00, 5-01
41	Overload of Digital Output Terminal 29	(X)			5-00, 5-02
42	Overload of Digital Output On X30/6	(X)			5-32
42	Overload of Digital Output On X30/7	(X)			5-33
46	Pwr. card supply		X	X	
47	24 V supply low	X	X	X	
48	1.8 V supply low		X	X	
49	Speed limit	X			
50	AMA calibration failed		X		
51	AMA check $U_{nom}$ and $I_{nom}$		X		
52	AMA low $I_{nom}$		X		
53	AMA motor too big		X		
54	AMA motor too small		X		
55	AMA parameter out of range		X		
56	AMA interrupted by user		X		
57	AMA timeout		X		
58	AMA internal fault	X	X		
59	Current limit	X			
60	External Interlock	X			
62	Output Frequency at Maximum Limit	X			
64	Voltage Limit	X			
65	Control Board Overtemperature	X	X	X	
66	Heatsink Temperature Low	X			
67	Option Configuration has Changed		X		
68	Safe Stop Activated		X <sup>1)</sup>		
69	Pwr. Card Temp		X	X	
70	Illegal FC configuration			X	
71	PTC 1 Safe Stop	X	X <sup>1)</sup>		
72	Dangerous Failure			X <sup>1)</sup>	
73	Safe Stop Auto Restart				
76	Power Unit Set-up	X			
79	Illegal PS config		X	X	
80	Drive Initialized to Default Value		X		
91	Analog input 54 wrong settings			X	
92	NoFlow	X	X		22-2*
93	Dry Pump	X	X		22-2*
94	End of Curve	X	X		22-5*
95	Broken Belt	X	X		22-6*
96	Start Delayed	X			22-7*
97	Stop Delayed	X			22-7*
98	Clock Fault	X			0-7*

Table 9.1: Alarm/Warning code list

No.	Description	Warning	Alarm/Trip	Alarm/Trip Lock	Parameter Reference
220	Overload Trip		X		
243	Brake IGBT	X	X		
244	Heatsink temp	X	X	X	
245	Heatsink sensor		X	X	
246	Pwr.card supply		X	X	
247	Pwr.card temp		X	X	
248	Illegal PS config		X	X	
250	New spare part			X	
251	New Type Code		X	X	

Table 9.2: Alarm/Warning code list

(X) Dependent on parameter

1) Cannot be auto reset via par. 14-20 *Reset Mode*

A trip is the action when an alarm has appeared. The trip will coast the motor and can be reset by pressing the reset button or make a reset by a digital input (Par. 5-1\* [1]). The original event that caused an alarm cannot damage the adjustable frequency drive or cause dangerous conditions. A trip lock is an action that occurs in conjunction with an alarm, which may cause damage to the adjustable frequency drive or connected parts. A trip lock situation can only be reset by power cycling.

<i>LED indication</i>	
Warning	yellow
Alarm	flashing red
Trip locked	yellow and red

<b>Alarm Word and Extended Status Word</b>					
Bit	Hex	Dec	Alarm Word	Warning Word	Extended Status Word
0	00000001	1	Brake Check	Brake Check	Ramping
1	00000002	2	Pwr. Card Temp	Pwr. Card Temp	AMA Running
2	00000004	4	Ground Fault	Ground Fault	Start CW/CCW
3	00000008	8	Ctrl.Card Temp	Ctrl.Card Temp	Slow Down
4	00000010	16	Ctrl. Word TO	Ctrl. Word TO	Catch Up
5	00000020	32	Overcurrent	Overcurrent	Feedback High
6	00000040	64	Torque Limit	Torque Limit	Feedback Low
7	00000080	128	Motor Th Over	Motor Th Over	Output Current High
8	00000100	256	Motor ETR Over	Motor ETR Over	Output Current Low
9	00000200	512	Inverter Overld.	Inverter Overld.	Output Freq High
10	00000400	1024	DC undervolt	DC undervolt	Output Freq Low
11	00000800	2048	DC overvolt	DC overvolt	Brake Check OK
12	00001000	4096	Short Circuit	DC Voltage Low	Braking Max
13	00002000	8192	Soft-charge Fault	DC Voltage High	Braking
14	00004000	16384	Line ph. Loss	Line ph. Loss	Out of Speed Range
15	00008000	32768	AMA Not OK	No Motor	OVC Active
16	00010000	65536	Live Zero Error	Live Zero Error	
17	00020000	131072	Internal Fault	10 V Low	
18	00040000	262144	Brake Overload	Brake Overload	
19	00080000	524288	U phase Loss	Brake Resistor	
20	00100000	1048576	V phase Loss	Brake IGBT	
21	00200000	2097152	W phase Loss	Speed Limit	
22	00400000	4194304	Serial Communication Fault	Serial Communication Fault	
23	00800000	8388608	24 V Supply Low	24V Supply Low	
24	01000000	16777216	Line Failure	Line Failure	
25	02000000	33554432	1.8 V Supply Low	Current Limit	
26	04000000	67108864	Brake Resistor	Low Temp	
27	08000000	134217728	Brake IGBT	Voltage Limit	
28	10000000	268435456	Option Change	Unused	
29	20000000	536870912	Drive Initialized	Unused	
30	40000000	1073741824	Safe Stop	Unused	

Table 9.3: Description of Alarm Word, Warning Word and Extended Status Word

The alarm words, warning words and extended status words can be read out via serial bus or optional serial communication bus for diagnosis. See also par. 16-90 *Alarm Word*, par. 16-92 *Warning Word* and par. 16-94 *Ext. Status Word*.

### 9.1.1 Fault Messages

**WARNING 1, 10 Volts low:**

The 10 V voltage from terminal 50 on the control card is below 10 V. Remove some of the load from terminal 50, as the 10 V supply is overloaded. Max. 15 mA or minimum 590 Ω.

**WARNING/ALARM 2, Live zero error:**

The signal on terminal 53 or 54 is less than 50% of the value set in par. 6-10 *Terminal 53 Low Voltage*, par. 6-12 *Terminal 53 Low Current*, par. 6-20 *Terminal 54 Low Voltage*, or par. 6-22 *Terminal 54 Low Current* respectively.

**WARNING/ALARM 3, No motor:**

No motor has been connected to the output of the adjustable frequency drive.

**WARNING/ALARM 4, Mains phs. loss:**

A phase is missing on the supply side, or the line voltage imbalance is too high.

This message also appears in case of a fault in the input rectifier on the adjustable frequency drive.

Check the supply voltage and supply currents to the adjustable frequency drive.

**WARNING 5, DC link voltage high:**

The intermediate circuit voltage (DC) is higher than the overvoltage limit of the control system. The adjustable frequency drive is still active.

**WARNING 6, DC link voltage low:**

The intermediate circuit voltage (DC) is below the undervoltage limit of the control system. The adjustable frequency drive is still active.

**WARNING/ALARM 7, DC overvoltage:**

If the intermediate circuit voltage exceeds the limit, the adjustable frequency drive trips after a time.

**Possible corrections:**

Select **Q**ver **V**oltage **C**ontrol function in par. 2-17 *Over-voltage Control*

Connect a brake resistor

Extend the ramp time

Activate functions in par. 2-10 *Brake Function*

Increase par. 14-26 *Trip Delay at Inverter Fault*

Selecting OVC function will extend the ramp times.

Alarm/warning limits:			
Voltage Range	3 x 200–240 V AC [VDC]	3 x 380–500 V AC [VDC]	3 x 550–600 V AC [VDC]
Undervoltage	185	373	532
Voltage warning low	205	410	585
Voltage warning high (w/o brake - w/ brake)	390/405	810/840	943/965
Overvoltage	410	855	975

The voltages stated are the intermediate circuit voltage of the adjustable frequency drive with a tolerance of ± 5%. The corresponding AC line voltage is the intermediate circuit voltage (DC link) divided by 1.35.

**WARNING/ALARM 8, DC undervoltage:**

If the intermediate circuit voltage (DC) drops below the “voltage warning low” limit (see table above), the adjustable frequency drive checks if 24 V backup supply is connected.

If no 24 V backup supply is connected, the adjustable frequency drive trips after a given time depending on the unit.

To check whether the supply voltage matches the adjustable frequency drive, see 3.1 *General Specifications*.

**WARNING/ALARM 9, Inverter overloaded:**

The adjustable frequency drive is about to cut out because of an overload (too high current for too long). The counter for electronic, thermal inverter protection gives a warning at 98% and trips at 100%, while giving an alarm. You cannot reset the adjustable frequency drive until the counter is below 90%.

The fault is that the adjustable frequency drive is overloaded by more than nominal current for too long.

**WARNING/ALARM 10, Motor ETR overtemperature:**

According to the electronic thermal protection (ETR), the motor is too hot. You can choose if you want the adjustable frequency drive to give a warning or an alarm when the counter reaches 100% in par. 1-90 *Motor Thermal Protection*. The fault is that the motor is overloaded by more than nominal current for too long. Make sure that the motor par. 1-24 *Motor Current* is set correctly.

**WARNING/ALARM 11, Motor thermistor overtemp:**

The thermistor or the thermistor connection is disconnected. You can choose if you want the adjustable frequency drive to give a warning or an alarm in par. 1-90 *Motor Thermal Protection*. Check that the thermistor is connected correctly between terminal 53 or 54 (analog voltage input) and terminal 50 (+ 10 Volts supply), or between terminal 18 or 19 (digital input PNP only) and terminal 50. If a KTY sensor is used, check for correct connection between terminal 54 and 55.

**WARNING/ALARM 12, Torque limit:**

The torque is higher than the value in par. 4-16 *Torque Limit Motor Mode* (in motor operation) or the torque is higher than the value in par. 4-17 *Torque Limit Generator Mode* (in regenerative operation).

**WARNING/ALARM 13, Overcurrent:**

The inverter peak current limit (approx. 200% of the rated current) is exceeded. The warning will last approx. 8-12 sec., then the adjustable frequency drive trips and issues an alarm. Turn off the adjustable frequency drive and check if the motor shaft can be turned and if the motor size matches the adjustable frequency drive.

**ALARM 14, Ground fault:**

There is a discharge from the output phases to ground, either in the cable between the adjustable frequency drive and the motor or in the motor itself.

Turn off the adjustable frequency drive and remove the ground fault.

**ALARM 15, Incomplete hardware:**

A fitted option is not handled by the present control board (hardware or software).

**ALARM 16, Short-circuit:**

There is short-circuiting in the motor or on the motor terminals.  
Turn off the adjustable frequency drive and remove the short-circuit.

**WARNING/ALARM 17, Control word timeout:**

There is no communication to the adjustable frequency drive.  
The warning will only be active when par. 8-04 *Control Timeout Function* is NOT set to OFF.  
If par. 8-04 *Control Timeout Function* is set to *Stop* and *Trip*, a warning appears and the adjustable frequency drive ramps down to zero speed, while giving an alarm.  
par. 8-03 *Control Timeout Time* could possibly be increased.

**WARNING 23, Internal fans:**

External fans have failed due to defect hardware or fans not mounted.

**WARNING 24, External fan fault:**

The fan warning function is an extra protection function that checks if the fan is running / mounted. The fan warning can be disabled in par. 14-53 *Fan Monitor*, [0] Disabled.

**WARNING 25, Brake resistor short-circuited:**


The brake resistor is monitored during operation. If it short-circuits, the brake function is disconnected and the warning appears. The adjustable frequency drive still works, but without the brake function. Turn off the adjustable frequency drive and replace the brake resistor (see par. 2-15 *Brake Check*).

**ALARM/WARNING 26, Brake resistor power limit:**

The power transmitted to the brake resistor is calculated as a percentage, as a mean value over the last 120 s, on the basis of the resistance value of the brake resistor (par. 2-11 *Brake Resistor (ohm)*) and the intermediate circuit voltage. The warning is active when the dissipated braking energy is higher than 90%. If *Trip* [2] has been selected in par. 2-13 *Brake Power Monitoring*, the adjustable frequency drive cuts out and issues this alarm, when the dissipated braking energy is higher than 100%.

**WARNING/ALARM 27, Brake chopper fault:**

The brake transistor is monitored during operation and if it short-circuits, the brake function disconnects and the warning comes up. The adjustable frequency drive is still able to run, but since the brake transistor has short-circuited, substantial power is transmitted to the brake resistor, even if it is inactive.  
Turn off the adjustable frequency drive and remove the brake resistor.



Warning: There is a risk of substantial power being transmitted to the brake resistor if the brake transistor is short-circuited.

**ALARM/WARNING 28, Brake check failed:**

Brake resistor fault: the brake resistor is not connected/working.

**WARNING/ALARM 29, Drive overtemperature:**

If the enclosure is IP00 or IP20/Nema1, the cut-out temperature of the heatsink is 194°F [90°C]. If IP54 is used, the cut-out temperature is 176°F [80°C].

**The fault could be:**

- Ambient temperature too high
- Too long motor cable

**ALARM 30, Motor phase U missing:**

Motor phase U between the adjustable frequency drive and the motor is missing.  
Turn off the adjustable frequency drive and check motor phase U.

**ALARM 31, Motor phase V missing:**

Motor phase V between the adjustable frequency drive and the motor is missing.  
Turn off the adjustable frequency drive and check motor phase V.

**ALARM 32, Motor phase W missing:**

Motor phase W between the adjustable frequency drive and the motor is missing.  
Turn off the adjustable frequency drive and check motor phase W.

**ALARM 33, Inrush fault:**

Too many power-ups have occurred within a short time period. See the chapter *General Specifications* for the allowed number of power-ups within one minute.

**WARNING/ALARM 34, Fieldbus communication fault:**

The serial communication bus on the communication option card is not working.

**WARNING/ALARM 35, Option Fault:**

Option fault. Please contact your supplier.

**WARNING/ALARM 36, Mains failure:**

This warning/alarm is only active if the supply voltage to the adjustable frequency drive is lost and parameter 14-10 is NOT set to OFF. Possible correction: check the fuses to the adjustable frequency drive

**WARNING/ALARM 37, Phase Imbalance:**

There is a current imbalance between the power units.

**ALARM 39, Heatsink Sensor:**

No feedback from the heatsink sensor.

**WARNING 40, Overload of Digital Output Terminal 27**

Check the load connected to terminal 27 or remove short-circuit connection. Check parameters 5-00 and 5-01.

**WARNING 41, Overload of Digital Output Terminal 29:**

Check the load connected to terminal 29 or remove short-circuit connection. Check parameters 5-00 and 5-02.

**WARNING 42, Overload of Digital Output On X30/6:**

Check the load connected to X30/6 or remove short-circuit connection. Check parameter 5-32.

**WARNING 42, Overload of Digital Output On X30/7:**

Check the load connected to X30/7 or remove short-circuit connection. Check parameter 5-33.

**ALARM 46, Pwr. card supply:**

The supply on the power card is out of range.

**WARNING 47, 24 V supply low:**

The external 24 V DC backup power supply may be overloaded, otherwise contact your Danfoss supplier.



**ALARM 48, 1.8 V supply low:**

Contact your Danfoss supplier.

**WARNING 49, Speed limit:**

The speed has been limited by range in par. 4-11 *Motor Speed Low Limit [RPM]* and par. 4-13 *Motor Speed High Limit [RPM]*.

**ALARM 50, AMA calibration failed:**

Contact your Danfoss supplier.

**ALARM 51, AMA check Unom and Inom:**

The setting of motor voltage, motor current, and motor power is presumably wrong. Check the settings.

**ALARM 52, AMA low Inom:**

The motor current is too low. Check the settings.

**ALARM 53, AMA motor too big:**

The motor is too big for the AMA to be carried out.

**ALARM 54, AMA motor too small:**

The motor is too small for the AMA to be carried out.

**ALARM 55, AMA par. out of range:**

The par. values found from the motor are outside acceptable range.

**ALARM 56, AMA interrupted by user:**

The AMA has been interrupted by the user.

**ALARM 57, AMA timeout:**

Try to start the AMA again a number of times, until the AMA is carried out. Please note that repeated runs may heat the motor to a level where the resistances  $R_s$  and  $R_r$  are increased. In most cases, however, this is not critical.

**WARNING/ALARM 58, AMA internal fault:**

Contact your Danfoss supplier.

**WARNING 59, Current limit:**

The current is higher than the value in par. 4-18 *Current Limit*.

**WARNING 60, External Interlock:**

External Interlock has been activated. To resume normal operation, apply 24 VDC to the terminal programmed for External Interlock and reset the adjustable frequency drive (via Bus, Digital I/O or by pressing [Reset]).

**WARNING 62, Output Frequency at Maximum Limit:**

The output frequency is limited by the value set in par. 4-19 *Max Output Frequency*

**WARNING/ALARM/TRIP 65, Control Card Overtemperature:**

Control card overtemperature: The cut-out temperature of the control card is 176°F (80°C).

**WARNING 66, Low Temp.:**

The heatsink temperature is measured to be low. This could indicate that the temperature sensor is defective and thus the fan speed is increased to the maximum in case the power part or control card is very hot.

**ALARM 67, Option Configuration has Changed:**

One or more options has either been added or removed since the last power-down.

**ALARM 68, Safe Stop:**

Safe Stop has been activated. To resume normal operation, apply 24 VDC to terminal 37, then send a reset signal (via Bus, Digital I/O or by pressing [Reset]).

**ALARM 69, Pwr. Card Temp:**

Power card overtemperature

**WARNING 76, Power Unit Set-up:**

The required number of power units does not match the detected number of active power units.

**ALARM 70, Illegal Adjustable Frequency Drive Configuration:**

Actual combination of control board and power board is illegal.

**ALARM 90, Feedback Mon.:****ALARM 92, No-Flow:**

A no load situation has been detected for the system. See parameter group 22-2\*.

**ALARM 93, Dry Pump:**

A no-flow situation and high speed indicates that the pump has run dry. See parameter group 22-2\*

**ALARM 94, End of Curve:**

Feedback stays lower than the setpoint, which may indicate a leakage in the pipe system. See parameter group 22-5\*

**ALARM 95, Broken Belt:**

Torque is below the torque level set for no load indicating a broken belt. See parameter group 22-6\*

**ALARM 96, Start Delayed:**

Start of the motor has been delayed due to short cycle protection being active. See parameter group 22-7\*.

**ALARM 220, Overload Trip:**

Motor overload has tripped. Indicates excess motor load. Check motor and driven load. To reset press the "Off Reset" key. Then, to restart the system, press the "Auto On" or "Hand On" key.

**WARNING/ALARM 243, Brake IGBT:**

The brake transistor is short-circuited or the brake function is disconnected. Turn off the adjustable frequency drive as a fire precaution. Report value indicates source of alarm (from left): 1-4 Inverter 5-8 Rectifier.

**WARNING/ALARM 244, Heatsink Temp:**

Drive heatsink overtemperature: Report value indicates source of alarm (from left): 1-4 Inverter 5-8 Rectifier.

**ALARM 245, Heatsink Sensor:**

No feedback from the heatsink sensor. Report value indicates source of alarm (from left): 1-4 Inverter 5-8 Rectifier.

**ALARM 246, Pwr. Card Supply:**

The supply on the power card is out of range. Report value indicates source of alarm (from left): 1-4 Inverter 5-8 Rectifier.

**ALARM 247, Pwr. Card Temp:**

Power card overtemperature. Report value indicates source of alarm (from left): 1-4 Inverter 5-8 Rectifier.

**ALARM 248, Illegal PS Config:**

Power size configuration fault on the power card. Report value indicates source of alarm (from left): 1-4 Inverter 5-8 Rectifier.

**ALARM 250, New Spare Part:**

The power or switch mode power supply has been exchanged. The adjustable frequency drive type code must be restored in the EEPROM. Select the correct type code in Par 14-23 according to the label on unit. Remember to select 'Save to EEPROM' to complete.

**ALARM 251, New Type Code:**

The adjustable frequency drive has a new type code.



## 10 Specifications

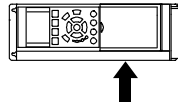
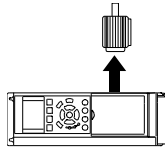
### 10.1 General Specifications

10

10.1.1 Line Power Supply 1 x 200–240 V AC

Line Power Supply 1 x 200–240 V AC - Normal overload 110% for 1 minute

Adjustable frequency drive Typical Shaft Output [kW]	P1K1	P1K5	P2K2	P3K0	P3K7	P5K5	P7K5	P15K	P22K
Typical Shaft Output [HP] at 240 V	1.1	1.5	2.2	3.0	3.7	5.5	7.5	15	22
IP 20 / Chassis	1.5	2.0	2.9	4.0	4.9	7.5	10	20	30
IP 21 / NEMA 1	A3	-	-	-	-	-	-	-	-
IP 55 / NEMA 12	-	B1	B1	B1	B1	B1	B2	C1	C2
IP 66	A5	B1	B1	B1	B1	B1	B2	C1	C2
<b>Output current</b>									
Continuous (3 x 200–240 V) [A]	6.6	7.5	10.6	12.5	16.7	24.2	30.8	59.4	88
Intermittent (3 x 200–240 V) [A]	7.3	8.3	11.7	13.8	18.4	26.6	33.4	65.3	96.8
Continuous KVA (208 V AC) [kVA]						5.00	6.40	12.27	18.30
Max. cable size: (line power, motor, brake) [[mm <sup>2</sup> / AWG] <sup>2</sup> ]			0.2-4 / 4-10			10/7	35/2	50/1/0	95/4/0
<b>Max. input current</b>									
Continuous (1 x 200–240 V) [A]	12.5	15	20.5	24	32	46	59	111	172
Intermittent (1 x 200–240 V) [A]	13.8	16.5	22.6	26.4	35.2	50.6	64.9	122.1	189.2
Max. pre-fuses <sup>1)</sup> [A]	20	30	40	40	60	80	100	150	200
Environment									
Estimated power loss at rated max. load [W] <sup>4)</sup>	44	30	44	60	74	110	150	300	440
Weight enclosure IP 20 [kg]	4.9	-	-	-	-	-	-	-	-
Weight enclosure IP 21 [kg]	-	23	23	23	23	23	27	45	65
Weight enclosure IP 55 [kg]	-	23	23	23	23	23	27	45	65
Weight enclosure IP 66 [kg]	-	23	23	23	23	23	27	45	65
Efficiency <sup>3)</sup>	0.968	0.98	0.98	0.98	0.98	0.98	0.98	0.98	0.98



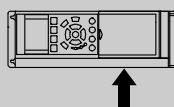
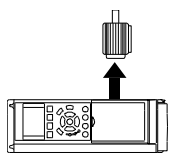




### 10.1.3 Line Power Supply 1 x 380–480 V AC

**Line Power Supply 1x 380 V AC - Normal overload 110% for 1 minute**

Adjustable frequency drive	P7K5	P11K	P18K	P37K
Typical Shaft Output [kW]	7.5	11	18.5	37
Typical Shaft Output [HP] at 460 V	10	15	25	50
IP 21 / NEMA 1	B1	B2	C1	C2
IP 55 / NEMA 12	B1	B2	C1	C2
IP 66	B1	B2	C1	C2
<b>Output current</b>				
Continuous (3 x 380–440 V) [A]	16	24	37.5	73
Intermittent (3 x 380–440 V) [A]	17.6	26.4	41.2	80.3
Continuous (3 x 441–480 V) [A]	14.5	21	34	65
Intermittent (3 x 441–480 V) [A]	15.4	23.1	37.4	71.5
Continuous kVA (400 V AC) [kVA]	11.0	16.6	26	50.6
Continuous kVA (460 V AC) [kVA]	11.6	16.7	27.1	51.8
Max. cable size: [(line power, motor, brake) [(mm <sup>2</sup> / AWG)] <sup>2</sup> ]	10/7	35/2	50/1/0	120/4/0
<b>Max. input current</b>				
Continuous (1 x 380–440 V) [A]	33	48	78	151
Intermittent (1 x 380–440 V) [A]	36	53	85.8	166
Continuous (1 x 441–480 V) [A]	30	41	72	135
Intermittent (1 x 441–480 V) [A]	33	46	79.2	148
Max. pre-fuses <sup>1)</sup> [A]	63	80	160	250
Environment				
Estimated power loss at rated max. load [W] <sup>4)</sup>	300	440	740	1480
Weight enclosure IP 21 [kg]	23	27	45	65
Weight enclosure IP 55 [kg]	23	27	45	65
Weight enclosure IP 66 [kg]	23	27	45	65
Efficiency <sup>3)</sup>	0.96	0.96	0.96	0.96





10

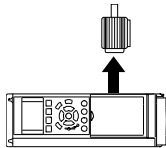
10.1.4 Line Power Supply 3 x 380–480 V AC

Line Power Supply 3 x 380–480 V AC - Normal overload 110% for 1 minute

Adjustable frequency drive	PK37	PK55	PK75	PK11	PK15	P2K2	P3K0	P4K0	P5K5	P7K5
Typical Shaft Output [kW]	0.37	0.55	0.75	1.1	1.5	2.2	3	4	5.5	7.5
Typical Shaft Output [HP] at 460 V	0.5	0.75	1.0	1.5	2.0	2.9	4.0	5.3	7.5	10
IP 20 / NEMA Chassis	A2	A2	A2	A2	A2	A2	A2	A2	A3	A3
IP 21 / NEMA 1	A5	A5	A5	A5	A5	A5	A5	A5	A5	A5
IP 55 / NEMA 12	A5	A5	A5	A5	A5	A5	A5	A5	AA	A5
IP 66	A5	A5	A5	A5	A5	A5	A5	A5	AA	A5

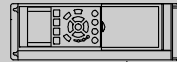
Output current

Continuous (3 x 380–440 V) [A]	1.3	1.8	2.4	3	4.1	5.6	7.2	10	13	16
Intermittent (3 x 380–440 V) [A]	1.43	1.98	2.64	3.3	4.5	6.2	7.9	11	14.3	17.6
Continuous (3 x 441–480 V) [A]	1.2	1.6	2.1	2.7	3.4	4.8	6.3	8.2	11	14.5
Intermittent (3 x 441–480 V) [A]	1.32	1.76	2.31	3.0	3.7	5.3	6.9	9.0	12.1	15.4
Continuous kVA (400 V AC) [kVA]	0.9	1.3	1.7	2.1	2.8	3.9	5.0	6.9	9.0	11.0
Continuous kVA (460 V AC) [kVA]	0.9	1.3	1.7	2.4	2.7	3.8	5.0	6.5	8.8	11.6
Max. cable size: (line power, motor, brake) [[mm <sup>2</sup> / AWG] <sup>2)</sup>	4/10									



Max. input current

Continuous (3 x 380–440 V) [A]	1.2	1.6	2.2	2.7	3.7	5.0	6.5	9.0	11.7	14.4
Intermittent (3 x 380–440 V) [A]	1.32	1.76	2.42	3.0	4.1	5.5	7.2	9.9	12.9	15.8
Continuous (3 x 441–480 V) [A]	1.0	1.4	1.9	2.7	3.1	4.3	5.7	7.4	9.9	13.0
Intermittent (3 x 441–480 V) [A]	1.1	1.54	2.09	3.0	3.4	4.7	6.3	8.1	10.9	14.3
Max. pre-fuses <sup>1)</sup> [A]	10	10	10	10	10	20	20	20	30	30
Environment										
Estimated power loss at rated max. load [W] <sup>4)</sup>	35	42	46	58	62	88	116	124	187	255
Weight enclosure IP20 [kg]	4.7	4.7	4.8	4.8	4.9	4.9	4.9	4.9	6.6	6.6
Weight enclosure IP 21 [kg]										
Weight enclosure IP 55 [kg]	13.5	13.5	13.5	13.5	13.5	13.5	13.5	13.5	14.2	14.2
Weight enclosure IP 66 [kg]	13.5	13.5	13.5	13.5	13.5	13.5	13.5	13.5	14.2	14.2
Efficiency <sup>3)</sup>	0.93	0.95	0.96	0.96	0.97	0.97	0.97	0.97	0.97	0.97

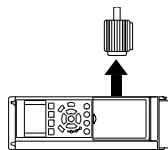


**Line Power Supply 3 x 380–480 V AC - Normal overload 110% for 1 minute**

Adjustable frequency drive	P11K	P15K	P18K	P22K	P30K	P37K	P45K	P55K	P75K	P90K
Typical Shaft Output [kW]	11	15	18.5	22	30	37	45	55	75	90
Typical Shaft Output [HP] at 460 V	15	20	25	30	40	50	60	75	100	125
IP 20 / NEMA Chassis (B3+4 and C3+4 may be converted to IP21 using a conversion kit (Please contact Danfoss))	B3	B3	B3	B4	B4	B4	C3	C3	C4	C4
IP 21 / NEMA 1	B1	B1	B1	B2	B2	C1	C1	C1	C2	C2
IP 55 / NEMA 12	B1	B1	B1	B2	B2	C1	C1	C1	C2	C2
IP 66	B1	B1	B1	B2	B2	C1	C1	C1	C2	C2

**Output current**

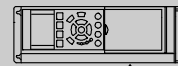
Continuous (3 x 380–440 V) [A]	24	32	37.5	44	61	73	90	106	147	177
Intermittent (3 x 380–440 V) [A]	26.4	35.2	41.3	48.4	67.1	80.3	99	117	162	195
Continuous (3 x 441–480 V) [A]	21	27	34	40	52	65	80	105	130	160
Intermittent (3 x 441–480 V) [A]	23.1	29.7	37.4	44	61.6	71.5	88	116	143	176
Continuous kVA (400 V AC) [kVA]	16.6	22.2	26	30.5	42.3	50.6	62.4	73.4	102	123
Continuous kVA (460 V AC) [kVA]	16.7	21.5	27.1	31.9	41.4	51.8	63.7	83.7	104	128



Max. cable size:  
(line power, motor, brake)  
[[mm<sup>2</sup>/ AWG] <sup>2)</sup>

**Max. input current**

Continuous (3 x 380–440 V) [A]	22	29	34	40	55	66	82	96	133	161
Intermittent (3 x 380–440 V) [A]	24.2	31.9	37.4	44	60.5	72.6	90.2	106	146	177
Continuous (3 x 441–480 V) [A]	19	25	31	36	47	59	73	95	118	145
Intermittent (3 x 441–480 V) [A]	20.9	27.5	34.1	39.6	51.7	64.9	80.3	105	130	160
Max. pre-fuses <sup>1)</sup> [A]	63	63	63	63	80	100	125	160	250	250
Environment										



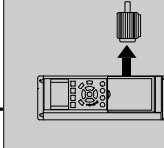
Estimated power loss at rated max. load [W] <sup>4)</sup>  
Weight enclosure IP20 [kg]  
Weight enclosure IP 21 [kg]  
Weight enclosure IP 55 [kg]  
Weight enclosure IP 66 [kg]  
Efficiency <sup>3)</sup>

Estimated power loss at rated max. load [W] <sup>4)</sup>	278	392	465	525	698	739	843	1083	1384	1474
Weight enclosure IP20 [kg]	12	12	12	23.5	23.5	23.5	35	35	50	50
Weight enclosure IP 21 [kg]	23	23	23	27	27	27	45	45	65	65
Weight enclosure IP 55 [kg]	23	23	23	27	27	27	45	45	65	65
Weight enclosure IP 66 [kg]	23	23	23	27	27	27	45	45	65	65
Efficiency <sup>3)</sup>	0.98	0.98	0.98	0.98	0.98	0.98	0.98	0.98	0.98	0.99

10

**Normal overload 110% for 1 minute**

Adjustable frequency drive	P110	P132	P160	P200	P250	P315	P355	P400	P450	P500	P560	P630	P710	P800	P1M0
Typical Shaft Output [kW] at 400 V	110	132	160	200	250	315	355	400	450	500	560	630	710	800	1000
Typical Shaft Output [HP] at 460V	150	200	250	300	350	450	500	550	600	700	750	900	1000	1200	1350
IP 00	D3	D3	D4	D4	D4	E2	E2	E2	E2	F1/F3	F1/F3	F1/F3	F1/F3	F1/F3	F2/F4
IP 21 / Nema 1	D1	D1	D2	D2	D2	E1	E1	E1	E1	F1/F3	F1/F3	F1/F3	F1/F3	F1/F3	F2/F4
IP 54 / Nema 12	D1	D1	D2	D2	D2	E1	E1	E1	E1	F1/F3	F1/F3	F1/F3	F1/F3	F1/F3	F2/F4



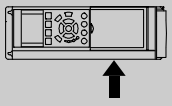
Continuous (3 x 380-440 V) [A]	212	260	315	395	480	600	658	745	800	880	990	1120	1260	1460	1720
Intermittent (3 x 380-440 V) [A]	233	286	347	435	528	660	724	820	880	968	1089	1232	1386	1606	1892
Continuous (3 x 441-480 V) [A]	190	240	302	361	443	540	590	678	730	780	890	1050	1160	1380	1530
Intermittent (3 x 441-480 V) [A]	209	264	332	397	487	594	649	746	803	858	979	1155	1276	1518	1683
Continuous kVA (400 V AC) [kVA]	147	180	218	274	333	416	456	516	554	610	686	776	873	1012	1192
Continuous kVA (460 V AC) [kVA]	151	191	241	288	353	430	470	540	582	621	709	837	924	1100	1219

Max. cable size:

(motor, ) [mm <sup>2</sup> / AWG <sup>2</sup> ]	2x70	2x2/0	2x185	2x300 mcm	4x240	8x150	12x150
(line power) [mm <sup>2</sup> / AWG <sup>2</sup> ]	2x70	2x2/0	2x185	2x300 mcm	4x500 mcm	8x300 mcm	12x300 mcm
(loadsharing) [mm <sup>2</sup> / AWG <sup>2</sup> ]	2x70	2x2/0	2x185	2x300 mcm	4x240	8x240	
(brake) [mm <sup>2</sup> / AWG <sup>2</sup> ]	2x70	2x2/0	2x185	2x300 mcm	4x240	4x185	6x185
					2x350 mcm	4x350 mcm	6x350 mcm

**Max. input current**

Continuous (3 x 380-440 V) [A]	204	251	304	381	463	590	647	733	787	857	964	1090	1227	1422	1675
Continuous (3 x 441-480 V) [A]	183	231	291	348	427	531	580	667	718	759	867	1022	1129	1344	1490
Max. pre-fuses <sup>1</sup> [A]	300	350	400	500	630	700	900	900	900	1600	1600	2000	2000	2500	2500
Environment:															
Estimated power loss at 400 V AC at rated max. load [W] <sup>4</sup>	3234	3782	4213	5119	5893	6790	7701	8879	9670	10647	12338	13201	15436	18084	20358
Estimated power loss at 460 V AC at rated max. load [W] <sup>4</sup>	2947	3665	4063	4652	5634	6082	6953	8089	8803	9414	11006	12353	14041	17137	17752
Weight enclosure IP00 [kg]	82	91	112	123	138	221	234	236	277	-	-	-	-	-	-
Weight enclosure IP 21 [kg]	96	104	125	136	151	263	270	272	313	1004	1004	1004	1004	1246	1246
Weight enclosure IP 54 [kg]	96	104	125	136	151	263	270	272	313	1299	1299	1299	1299	1541	1541
Efficiency <sup>3</sup>	0.98	0.98	0.98	0.98	0.98	0.98	0.98	0.98	0.98	0.98	0.98	0.98	0.98	0.98	0.98



<sup>1</sup> For type of fuse see section Fuses

<sup>2</sup> American Wire Gauge

<sup>3</sup> Measured using 16 ft [5 m] shielded motor cables at rated load and rated frequency

<sup>4</sup> The typical power loss is at normal load conditions and expected to be within +/-15% (tolerance relates to variety in voltage and cable conditions). Values are based on a typical motor efficiency (eff2/eff3 border line). Lower efficiency motors will also add to the power loss in the adjustable frequency drive and vice versa.

If the switching frequency is raised from nominal, the power losses may rise significantly.

LCP and typical control card power consumptions are included. Further options and customer load may add up to 30 W to the losses. (Though typically only 4 W extra for a fully loaded control card or options for slot A or slot B, each).

Although measurements are made with state of the art equipment, some measurement inaccuracy must be allowed for (+/- 5%).

### 10.1.5 Line Power Supply 3 x 525–600 V AC

Normal overload 110% for 1 minute																		
Size:	PK75	P1K1	P1K5	P2K2	P3K0	P4K0	P5K5	P7K5	P11K	P15K	P18K	P22K	P30K	P37K	P45K	P55K	P75K	P90K
Typical Shaft Output [kW]	0.75	1.1	1.5	2.2	3	4	5.5	7.5	11	15	18.5	22	30	37	45	55	75	90
IP 20 / NEMA Chassis	A2	A2	A2	A2	A2	A2	A3	A3	B3	B3	B3	B4	B4	B4	C3	C3	C4	C4
IP 21 / NEMA 1	A2	A2	A2	A2	A2	A2	A3	A3	B1	B1	B1	B2	B2	B2	C1	C1	C2	C2
IP 55 / NEMA 12	A5	A5	A5	A5	A5	A5	A5	A5	B1	B1	B1	B2	B2	B2	C1	C1	C2	C2
IP 66	A5	A5	A5	A5	A5	A5	A5	A5	B1	B1	B1	B2	B2	B2	C1	C1	C2	C2
Output current																		
Continuous (3 x 525–550 V) [A]	1.8	2.6	2.9	4.1	5.2	6.4	9.5	11.5	19	23	28	36	43	54	65	87	105	137
Intermittent (3 x 525–550 V) [A]	2.9	3.2	3.2	4.5	5.7	7.0	10.5	12.7	21	25	31	40	47	59	72	96	116	151
Continuous (3 x 525–600 V) [A]	1.7	2.4	2.7	3.9	4.9	6.1	9.0	11.0	18	22	27	34	41	52	62	83	100	131
Intermittent (3 x 525–600 V) [A]	2.6	3.0	3.0	4.3	5.4	6.7	9.9	12.1	20	24	30	37	45	57	68	91	110	144
Continuous kVA (525 V AC) [kVA]	1.7	2.5	2.8	3.9	5.0	6.1	9.0	11.0	18.1	21.9	26.7	34.3	41	51.4	61.9	82.9	100	130.5
Continuous kVA (575 V AC) [kVA]	1.7	2.4	2.7	3.9	4.9	6.1	9.0	11.0	17.9	21.9	26.9	33.9	40.8	51.8	61.7	82.7	99.6	130.5
Max. cable size (line power, motor, brake) [AWG] <sup>2)</sup> [mm <sup>2</sup> ]	24 - 10 AWG 0.2 - 4																	
Max. input current																		
Continuous (3 x 525–600 V) [A]	1.7	2.4	2.7	4.1	5.2	6.4	9.5	11.5	17.2	20.9	25.4	32.7	39	49	59	78.9	95.3	124.3
Intermittent (3 x 525–600 V) [A]	2.7	3.0	3.0	4.5	5.7	7.0	10.5	12.7	19	23	28	36	43	54	65	87	105	137
Max. pre-fuses <sup>1)</sup> [A]	10	10	10	20	20	20	32	32	40	40	50	60	80	100	150	160	225	250
Environment:																		
Estimated power loss at rated max. load [W] <sup>4)</sup>	35	50	65	92	122	145	195	261	225	285	329	460	560	740	860	890	1020	1130
Weight [kg]:																		
Enclosure IP20	6.5	6.5	6.5	6.5	6.5	6.5	6.6	6.6	12	12	12	23.5	23.5	23.5	35	35	50	50
Efficiency <sup>4)</sup>	0.97	0.97	0.97	0.97	0.97	0.97	0.97	0.97	0.98	0.98	0.98	0.98	0.98	0.98	0.98	0.98	0.98	0.98

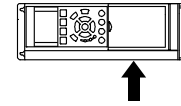
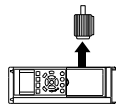


Table 10.1: <sup>5)</sup> Motor and line cable: 300MCM/150mm<sup>2</sup>

10

10.1.6 Line Power Supply 3 x 525–690 V AC

Normal overload 110% for 1 minute												
Size:	P11K	P15K	P18K	P22K	P30K	P37K	P45K	P55K	P75K	P90K		
Typical Shaft Output [kW]	11	15	18.5	22	30	37	45	55	75	90		
Typical Shaft Output [HP] at 575 V	10	16.4	20.1	24	33	40	50	60	75	100		
IP 21 / NEMA 1	B2	B2	B2	B2	B2	C2	C2	C2	C2	C2		
IP 55 / NEMA 12	B2	B2	B2	B2	B2	C2	C2	C2	C2	C2		
<b>Output current</b>												
Continuous (3 x 525–550 V) [A]	14	19	23	28	36	43	54	65	87	105		
Intermittent (3 x 525–550 V) [A]	15.4	20.9	25.3	30.8	39.6	47.3	59.4	71.5	95.7	115.5		
Continuous (3 x 551–690 V) [A]	13	18	22	27	34	41	52	62	83	100		
Intermittent (3 x 551–690 V) [A]	14.3	19.8	24.2	29.7	37.4	45.1	57.2	68.2	91.3	110		
Continuous kVA (550 V AC) [kVA]	13.3	18.1	21.9	26.7	34.3	41	51.4	61.9	82.9	100		
Continuous kVA (575 V AC) [kVA]	12.9	17.9	21.9	26.9	33.8	40.8	51.8	61.7	82.7	99.6		
Continuous kVA (690 V AC) [kVA]	15.5	21.5	26.3	32.3	40.6	49	62.1	74.1	99.2	119.5		
Max. cable size (line power, motor, brake) [mm <sup>2</sup> ]/[AWG] <sup>2)</sup>	35 1/0											
<b>Max. input current</b>												
Continuous (3 x 525–690 V) [A]	15	19.5	24	29	36	49	59	71	87	99		
Intermittent (3 x 525–690 V) [A]	16.5	21.5	26.4	31.9	39.6	53.9	64.9	78.1	95.7	108.9		
Max. pre-fuses <sup>1)</sup> [A]	63	63	63	63	80	100	125	160	160	160		
Environment:												
Estimated power loss at rated max. load [W] <sup>4)</sup>	201	285	335	375	430	592	720	880	1200	1440		
Weight:												
IP21 [kg]	27	27	27	27	27	65	65	65	65	65		
IP55 [kg]	27	27	27	27	27	65	65	65	65	65		
Efficiency <sup>4)</sup>	0.98	0.98	0.98	0.98	0.98	0.98	0.98	0.98	0.98	0.98		

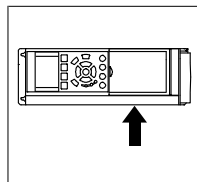
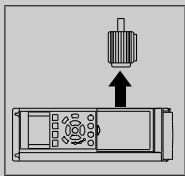


Table 10.2: <sup>5)</sup> Motor and line cable: 300MCM/150mm<sup>2</sup>

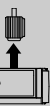
### 10.1.7 Line Power Supply 3 x 525–690 V AC

#### Normal overload 110% for 1 minute

	P45K	P55K	P75K	P90K	P110	P132	P160	P200	P250	P315	P400	P450	P500	P560	P630	P710	P800	P900	P1M0	P1M2
Adjustable frequency drive	45	55	75	90	110	132	160	200	250	315	400	450	500	560	630	710	800	900	1000	1200
Typical Shaft Output [kW]	50	60	75	100	125	150	200	250	300	350	400	450	500	600	650	750	950	1050	1150	1350
Typical Shaft Output [HP] at 575 V	D3	D3	D3	D3	D3	D3	D3	D4	D4	D4	D4	E2	E2	E2	E2	-	F1/ F3 <sup>6)</sup>	F1/ F3 <sup>6)</sup>	F1/ F3 <sup>6)</sup>	F2/ F4 <sup>6)</sup>
IP 00	D1	D1	D1	D1	D1	D1	D1	D2	D2	D2	D2	E1	E1	E1	E1	-	F1/ F3 <sup>6)</sup>	F1/ F3 <sup>6)</sup>	F1/ F3 <sup>6)</sup>	F2/ F4 <sup>6)</sup>
IP 21 / Nema 1	D1	D1	D1	D1	D1	D1	D1	D2	D2	D2	D2	E1	E1	E1	E1	-	F1/ F3 <sup>6)</sup>	F1/ F3 <sup>6)</sup>	F1/ F3 <sup>6)</sup>	F2/ F4 <sup>6)</sup>
IP 54 / Nema 12	D1	D1	D1	D1	D1	D1	D1	D2	D2	D2	D2	E1	E1	E1	E1	-	F1/ F3 <sup>6)</sup>	F1/ F3 <sup>6)</sup>	F1/ F3 <sup>6)</sup>	F2/ F4 <sup>6)</sup>

#### Output current

Continuous (3 x 550 V) [A]	56	76	90	113	137	162	201	253	303	360	418	470	523	596	630	763	889	988	1108	1317
Intermittent (3 x 550 V) [A]	62	84	99	124	151	178	221	278	333	396	460	517	575	656	693	839	978	1087	1219	1449
Continuous (3 x 690 V) [A]	54	73	86	108	131	155	192	242	290	344	400	450	500	570	630	730	850	945	1060	1260
Intermittent (3 x 690 V) [A]	59	80	95	119	144	171	211	266	319	378	440	495	550	627	693	803	935	1040	1166	1386
Continuous kVA (550 V AC) [kVA]	53	72	86	108	131	154	191	241	289	343	398	448	498	568	600	727	847	941	1056	1255
Continuous kVA (575 V AC) [kVA]	54	73	86	108	130	154	191	241	289	343	398	448	498	568	627	727	847	941	1056	1255
Continuous kVA (690 V AC) [kVA]	65	87	103	129	157	185	229	289	347	411	478	538	598	681	753	872	1016	1129	1267	1506

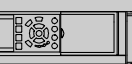


#### Max. cable size:

(line power) [mm <sup>2</sup> / AWG] <sup>2)</sup>	2x70	2x240	2x300 mcm	2x185	2x300 mcm	4x240	4x500 mcm	8x240	8x500 mcm
(Motor) [mm <sup>2</sup> / AWG] <sup>2)</sup>	2x70	2x240	2x300 mcm	2x185	2x300 mcm	4x240	4x500 mcm	8x150	12x150
(Brake) [mm <sup>2</sup> / AWG] <sup>2)</sup>	2x70	2x240	2x300 mcm	2x185	2x300 mcm	2x185	2x350 mcm	4x185	6x185
	2x240	2x350 mcm	2x350 mcm	2x350 mcm	2x350 mcm	2x350 mcm	2x350 mcm	4x350 mcm	6x350 mcm

#### Max. input current

Continuous (3 x 550 V) [A]	60	77	89	110	130	158	198	245	299	355	408	453	504	574	607	743	866	962	1079	1282
Continuous (3 x 575 V) [A]	58	74	85	106	124	151	189	224	286	339	390	434	482	549	607	711	828	920	1032	1227
Continuous (3 x 690 V) [A]	58	77	87	109	128	155	197	240	296	352	400	434	482	549	607	711	828	920	1032	1227
Max. line power pre-fuses <sup>3)</sup> [A]	125	160	200	200	250	315	350	350	400	500	550	700	700	900	900	2000	2000	2000	2000	2000



#### Environment:

Estimated power loss at 690 VAC at rated max. load [W] <sup>4)</sup>	1458	1717	1913	2262	2662	3430	3612	4292	5156	5821	6149	6440	7249	8727	9673	11315	1290	14533	1637	19207
Estimated power loss at 575 VAC at rated max. load [W] <sup>4)</sup>	1398	1645	1827	2157	2533	2963	3430	4051	4867	5493	5852	6132	6903	8343	9244	10771	1227	13835	1559	18281
Weight enclosure IP00 [kg]	82	82	82	82	82	82	91	112	123	138	151	221	221	236	277	-	-	-	-	-
Weight enclosure IP21 [kg] <sup>6)</sup>	96	96	96	96	96	96	104	125	136	151	165	263	263	272	313	1004	1004	1004	1004	1246
Weight enclosure IP54 [kg] <sup>6)</sup>	96	96	96	96	96	96	104	125	136	151	165	263	263	272	313	1004	1004	1004	1004	1246
Efficiency <sup>3)</sup>	0.97	0.97	0.98	0.98	0.98	0.98	0.98	0.98	0.98	0.98	0.98	0.98	0.98	0.98	0.98	0.98	0.98	0.98	0.98	0.98

1) For type of fuse see section Fuses  
 2) American Wire Gauge  
 3) Measured using 16 ft [5 m] shielded motor cables at rated load and rated frequency  
 4) The typical power loss is at normal load conditions and expected to be within +/- 15% (tolerance relates to variety in voltage and cable conditions). Values are based on a typical motor efficiency (eff2/eff3 border line). Lower efficiency motors will also add to the power loss in the adjustable frequency drive and vice versa.  
 If the switching frequency is raised from nominal the power losses may rise significantly. LCP and typical control card power consumptions are included. Further options and customer load may add up to 30 [W] to the losses. (Though typically only 4 [W] extra for a fully loaded control card, or options for slot A or slot B, each).  
 Although measurements are made with state of the art equipment, some measurement inaccuracy must be allowed for (+/- 5%).  
 6) Adding the F-enclosure option cabinet (resulting in the F3 and F4 enclosure sizes) adds 650 lbs [295 kg] to the estimated weight.

## Protection and Features:

- Electronic thermal motor protection against overload.
- Temperature monitoring of the heatsink ensures that the adjustable frequency drive trips if the temperature reaches  $203^{\circ}\text{F} \pm 41^{\circ}\text{F}$  [ $95^{\circ}\text{C} \pm 5^{\circ}\text{C}$ ]. An overload temperature cannot be reset until the temperature of the heatsink is below  $158^{\circ}\text{F} \pm 9^{\circ}\text{F}$  [ $70^{\circ}\text{C} \pm 5^{\circ}\text{C}$ ] (Guideline - these temperatures may vary for different power sizes, enclosures etc.). VLT AQUA Drive has an auto derating function to avoid it's heatsink reaching  $203^{\circ}\text{F}$  [ $95^{\circ}\text{C}$ ].
- The adjustable frequency drive is protected against short-circuits on motor terminals U, V, W.
- If a line phase is missing, the adjustable frequency drive trips or issues a warning (depending on the load).
- Monitoring of the intermediate circuit voltage ensures that the adjustable frequency drive trips if the intermediate circuit voltage is too low or too high.
- The adjustable frequency drive is protected against ground faults on motor terminals U, V, W.

## Line power supply (L1, L2, L3):

Supply voltage	200–240 V $\pm 10\%$
Supply voltage	380–480 V $\pm 10\%$
Supply voltage	525–600 V $\pm 10\%$
Supply voltage	525–690 V $\pm 10\%$

*AC line voltage low / line drop-out:*

*During low AC line voltage or a line drop-out, the adjustable frequency drive continues until the intermediate circuit voltage drops below the minimum stop level, which corresponds typically to 15% below the adjustable frequency drive's lowest rated supply voltage. Power-up and full torque cannot be expected at AC line voltage lower than 10% below the adjustable frequency drive's lowest rated supply voltage.*

Supply frequency	50/60 Hz +4/-6%
------------------	-----------------

*The adjustable frequency drive power supply is tested in accordance with IEC61000-4-28, 50 Hz +4/-6%.*

Max. imbalance temporary between line phases	3.0% of rated supply voltage
True Power Factor ( $\Lambda$ )	$\geq 0.9$ nominal at rated load
Displacement Power Factor ( $\cos\phi$ ) near unity	(> 0.98)
Switching on input supply L1, L2, L3 (power-ups) $\leq$ enclosure type A	maximum 2 times/min.
Switching on input supply L1, L2, L3 (power-ups) $\geq$ enclosure type B, C	maximum 1 time/min.
Switching on input supply L1, L2, L3 (power-ups) $\geq$ enclosure type D, E, F	maximum 1 time/2 min.
Environment according to EN60664-1	overvoltage category III/pollution degree 2

*The unit is suitable for use on a circuit capable of delivering not more than 100.000 RMS symmetrical Amperes, 240/480 V maximum.*

## Motor output (U, V, W):

Output voltage	0–100% of supply voltage
Output frequency	0–1000 Hz*
Switching on output	Unlimited
Ramp times	1–3600 sec.

*\* Dependent on power size.*

## Torque characteristics:

Starting torque (Constant torque)	maximum 110% for 1 min.*
Starting torque	maximum 135% up to 0.5 sec.*
Overload torque (Constant torque)	maximum 110% for 1 min.*

*\*Percentage relates to VLT AQUA Drive's nominal torque.*

## Cable lengths and cross-sections:

Max. motor cable length, shielded/armored	VLT AQUA Drive: 492 ft [150 m]
Max. motor cable length, unshielded/unarmored	VLT AQUA Drive: 984 ft [300 m]
Max. cross-section to motor, line power, load sharing and brake *	
Maximum cross-section to control terminals, rigid wire	0.0023 in <sup>2</sup> [1.5 mm <sup>2</sup> ]/16 AWG (2 x 0.00112 <sup>2</sup> in [0.75 mm <sup>2</sup> ])
Maximum cross-section to control terminals, flexible cable	0.0016 in <sup>2</sup> [1 mm <sup>2</sup> ]/18 AWG
Maximum cross-section to control terminals, cable with enclosed core	0.0008 in <sup>2</sup> [0.5 mm <sup>2</sup> ]/20 AWG

Minimum cross-section to control terminals 0.25 mm<sup>2</sup>

*\* See Line Power Supply tables for more information!*

Control card, RS-485 serial communication:

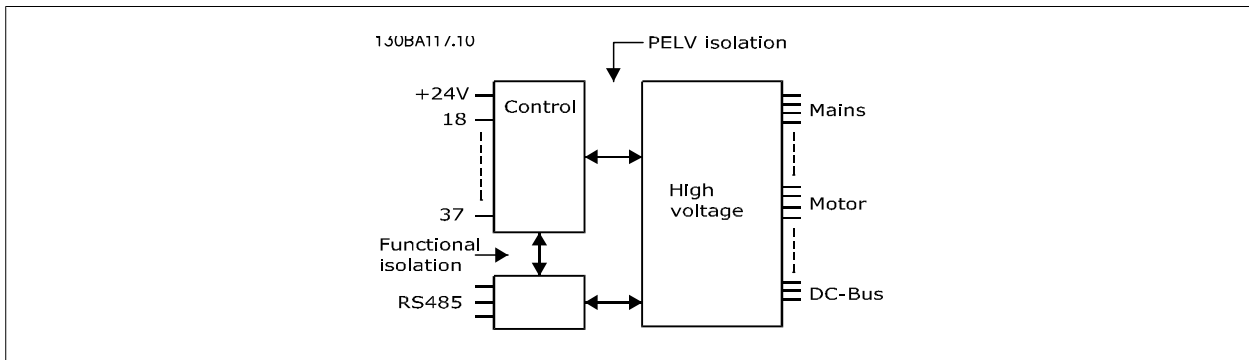
Terminal number	68 (P,TX+, RX+), 69 (N,TX-, RX-)
Terminal number 61	Common for terminals 68 and 69

*The RS-485 serial communication circuit is functionally seated from other central circuits and galvanically isolated from the supply voltage (PELV).*

Analog inputs:

Number of analog inputs	2
Terminal number	53, 54
Modes	Voltage or current
Mode select	Switch S201 and switch S202
Voltage mode	Switch S201/switch S202 = OFF (U)
Voltage level	: 0–+10 V (scaleable)
Input resistance, R <sub>i</sub>	approx. 10 kΩ
Max. voltage	± 20 V
Current mode	Switch S201/switch S202 = ON (I)
Current level	0/4 to 20 mA (scaleable)
Input resistance, R <sub>i</sub>	approx. 200 Ω
Max. current	30 mA
Resolution for analog inputs	10 bit (+ sign)
Accuracy of analog inputs	Max. error 0.5% of full scale
Bandwidth	: 200 Hz

*The analog inputs are galvanically isolated from the supply voltage (PELV) and other high-voltage terminals.*



10

Analog output:

Number of programmable analog outputs	1
Terminal number	42
Current range at analog output	0/4 - 20 mA
Max. resistor load to common at analog output	500 Ω
Accuracy on analog output	Max. error: 0.8% of full scale
Resolution on analog output	8 bit

*The analog output is galvanically isolated from the supply voltage (PELV) and other high-voltage terminals.*

Digital inputs:

Programmable digital inputs	4 (6)
Terminal number	18, 19, 27 <sup>1)</sup> , 29 <sup>1)</sup> , 32, 33,
Logic	PNP or NPN
Voltage level	0–24 V DC
Voltage level, logic'0' PNP	< 5 V DC
Voltage level, logic'1' PNP	> 10 V DC
Voltage level, logic '0' NPN	> 19 V DC



Voltage level, logic '1' NPN	< 14 V DC
Maximum voltage on input	28 V DC
Input resistance, $R_i$	approx. 4 k

All digital inputs are galvanically isolated from the supply voltage (PELV) and other high-voltage terminals.

1) Terminals 27 and 29 can also be programmed as output.

#### Digital output:

Programmable digital/pulse outputs	2
Terminal number	27, 29 <sup>1)</sup>
Voltage level at digital/frequency output	0–24 V
Max. output current (sink or source)	40 mA
Max. load at frequency output	1 k $\Omega$
Max. capacitive load at frequency output	10 nF
Minimum output frequency at frequency output	0 Hz
Maximum output frequency at frequency output	32 kHz
Accuracy of frequency output	Max. error: 0.1% of full scale
Resolution of frequency outputs	12 bit

1) Terminal 27 and 29 can also be programmed as input.

The digital output is galvanically isolated from the supply voltage (PELV) and other high-voltage terminals.

#### Pulse inputs:

Programmable pulse inputs	2
Terminal number pulse	29, 33
Max. frequency at terminal, 29, 33	110 kHz (push-pull driven)
Max. frequency at terminal, 29, 33	5 kHz (open collector)
Min. frequency at terminal 29, 33	4 Hz
Voltage level	see section on Digital input
Maximum voltage on input	28 V DC
Input resistance, $R_i$	approx. 4 k $\Omega$
Pulse input accuracy (0.1–1 kHz)	Max. error: 0.1% of full scale

#### Control card, 24 V DC output:

Terminal number	12, 13
Max. load	: 200 mA

The 24 V DC supply is galvanically isolated from the supply voltage (PELV), but has the same potential as the analog and digital inputs and outputs.

#### Relay outputs:

Programmable relay outputs	2
<b>Relay 01 Terminal number</b>	1-3 (break), 1-2 (make)
Max. terminal load (AC-1) <sup>1)</sup> on 1-3 (NC), 1-2 (NO) (Resistive load)	240 V AC, 2 A
Max. terminal load (AC-15) <sup>1)</sup> (Inductive load @ $\cos\phi$ 0.4)	240 V AC, 0.2 A
Max. terminal load (DC-1) <sup>1)</sup> on 1-2 (NO), 1-3 (NC) (Resistive load)	60 V DC, 1A
Max. terminal load (DC-13) <sup>1)</sup> (Inductive load)	24 V DC, 0.1 A
<b>Relay 02 Terminal number</b>	4-6 (break), 4-5 (make)
Max. terminal load (AC-1) <sup>1)</sup> on 4-5 (NO) (Resistive load) <sup>2)3)</sup>	400 V AC, 2 A
Max. terminal load (AC-15) <sup>1)</sup> on 4-5 (NO) (Inductive load @ $\cos\phi$ 0.4)	240 V AC, 0.2 A
Max. terminal load (DC-1) <sup>1)</sup> on 4-5 (NO) (Resistive load)	80 V DC, 2 A
Max. terminal load (DC-13) <sup>1)</sup> on 4-5 (NO) (Inductive load)	24 V DC, 0.1 A
Max. terminal load (AC-1) <sup>1)</sup> on 4-6 (NC) (Resistive load)	240 V AC, 2 A
Max. terminal load (AC-15) <sup>1)</sup> on 4-6 (NC) (Inductive load @ $\cos\phi$ 0.4)	240 V AC, 0.2 A
Max. terminal load (DC-1) <sup>1)</sup> on 4-6 (NC) (Resistive load)	50 V DC, 2 A
Max. terminal load (DC-13) <sup>1)</sup> on 4-6 (NC) (Inductive load)	24 V DC, 0.1 A
Min. terminal load on 1-3 (NC), 1-2 (NO), 4-6 (NC), 4-5 (NO)	24 V DC 10 mA, 24 V AC 20 mA

Environment according to EN 60664-1

overvoltage category III/pollution degree 2

1) IEC 60947 part 4 and 5

The relay contacts are galvanically isolated from the rest of the circuit by reinforced isolation (PELV).

2) Overvoltage Category II

3) UL applications 300 V AC 2 A

Control card, 10 V DC output:

Terminal number	50
Output voltage	10.5 V ±0.5 V
Max. load	25 mA

The 10 V DC supply is galvanically isolated from the supply voltage (PELV) and other high-voltage terminals.

Control characteristics:

Resolution of output frequency at 0 - 1000 Hz	: +/- 0.003 Hz
System response time (terminals 18, 19, 27, 29, 32, 33)	: ≤ 2 ms
Speed control range (open-loop)	1:100 of synchronous speed
Speed accuracy (open-loop)	30–4000 rpm: Maximum error of ±8 rpm

All control characteristics are based on a 4-pole asynchronous motor

Surroundings:

Enclosure type A	IP 20/Chassis, IP 21kit/Type 1, IP55/Type12, IP 66
Enclosure type B1/B2	IP 21/Type 1, IP55/Type12, IP 66
Enclosure type B3/B4	IP20/Chassis
Enclosure type C1/C2	IP 21/Type 1, IP55/Type 12, IP66
Enclosure type C3/C4	IP20/Chassis
Enclosure type D1/D2/E1	IP21/Type 1, IP54/Type12
Enclosure type D3/D4/E2	IP00/Chassis
Enclosure kit available ≤ enclosure type A	IP21/TYP1 1/IP 4X top
Vibration test enclosure A/B/C	1.0 g
Vibration test enclosure D/E/F	0.7 g
Max. relative humidity	5%–95%(IEC 721-3-3; Class 3K3 (non-condensing) during operation
Aggressive environment (IEC 721-3-3), uncoated	class 3C2
Aggressive environment (IEC 721-3-3), coated	class 3C3
Test method according to IEC 60068-2-43 H2S (10 days)	
Ambient temperature	Max. 122°F [50°C]

Derating for high ambient temperature, see section on special conditions

Minimum ambient temperature during full-scale operation	32°F [0°C]
Minimum ambient temperature at reduced performance	14°F [-10°C]
Temperature during storage/transport	-13°–+°149/°158°F [-25°–+65°/70°C]
Maximum altitude above sea level without derating	3280 ft [1000 m]
Maximum altitude above sea level with derating	9842 ft [3000 m]

Derating for high altitude, see section on special conditions.

EMC standards, Emission	EN 61800-3, EN 61000-6-3/4, EN 55011, IEC 61800-3 EN 61800-3, EN 61000-6-1/2,
EMC standards, Immunity	EN 61000-4-2, EN 61000-4-3, EN 61000-4-4, EN 61000-4-5, EN 61000-4-6

See section on special conditions

Control card performance:

Scan interval	: 5 ms
---------------	--------

Control card, USB serial communication:

USB standard	1.1 (Full speed)
USB plug	USB type B "device" plug



Connection to PC is carried out via a standard host/device USB cable.

The USB connection is galvanically isolated from the supply voltage (PELV) and other high-voltage terminals.

The USB connection is not galvanically isolated from protection ground. Only use an isolated laptop/PC as the connection to the USB connector on an VLT AQUA Drive or an isolated USB cable/driver.

## 10.2 Special Conditions

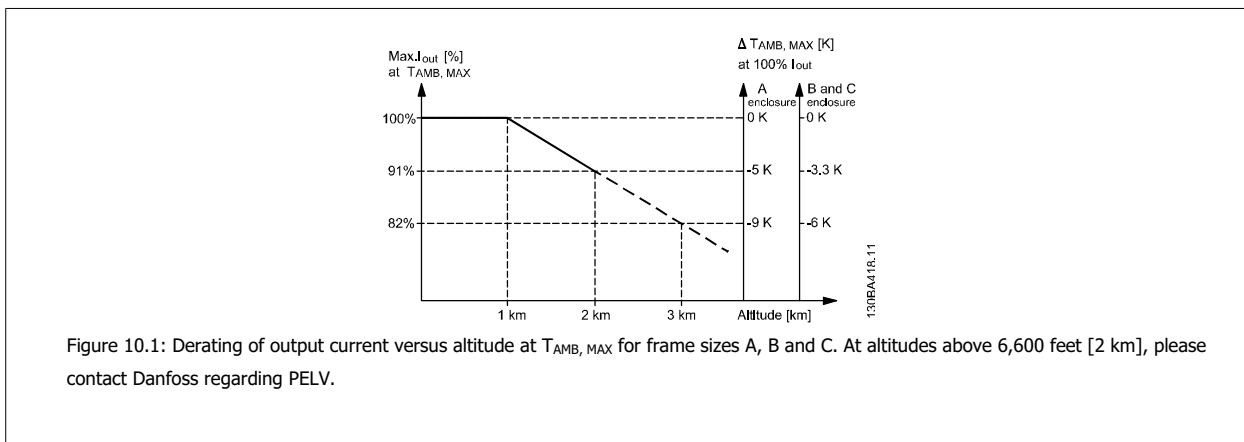
### 10.2.1 Purpose of Derating

Derating must be taken into account when using the adjustable frequency drive at low air pressure (high elevations), at low speeds, with long motor cables, cables with a large cross-section or at high ambient temperature. The required action is described in this section.

### 10.2.2 Derating for Low Air Pressure

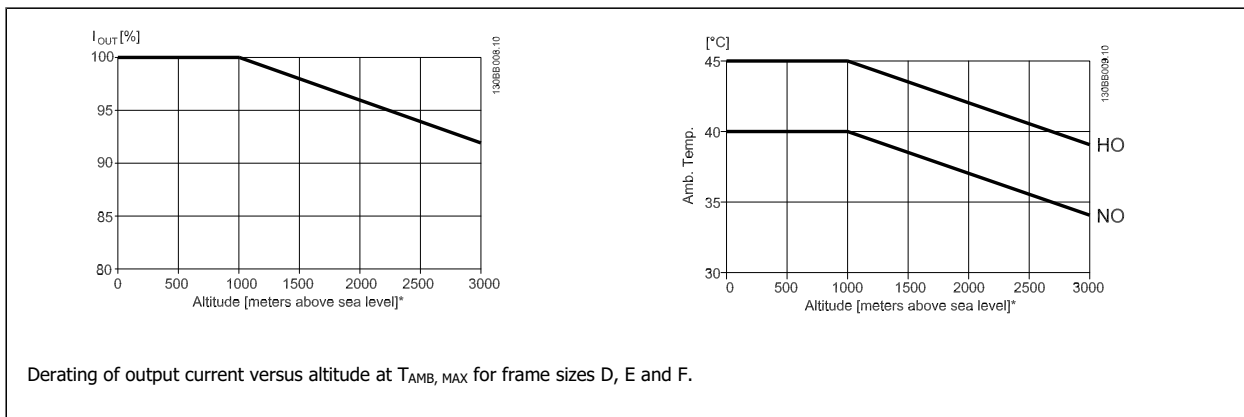
The cooling capability of air is decreased at a lower air pressure.

At an altitude lower than 3,280 ft [1,000 m], no derating is necessary, but above 3,280 ft [1,000 m], the ambient temperature ( $T_{AMB}$ ) or max. output current ( $I_{out}$ ) should be derated in accordance with the diagram shown.



**10**

An alternative is to lower the ambient temperature at high altitudes and thereby ensure 100% output current at high altitudes. As an example of how to read the graph, the situation at 6,600 ft [2 km] is elaborated. At a temperature of 113°F [45°C] ( $T_{AMB, MAX} - 3.3$  K), 91% of the rated output current is available. At a temperature of 107°F [41.7°C], 100% of the rated output current is available.



### 10.2.3 Derating for Running at Low Speed

When a motor is connected to an adjustable frequency drive, it is necessary to make sure that the cooling of the motor is adequate. The level of heating depends on the load on the motor as well as the operating speed and time.

#### Constant torque applications (CT mode)

A problem may occur at low RPM values in constant torque applications. In a constant torque application, a motor may overheat at low speeds due to less cooling air from the motor integral fan.

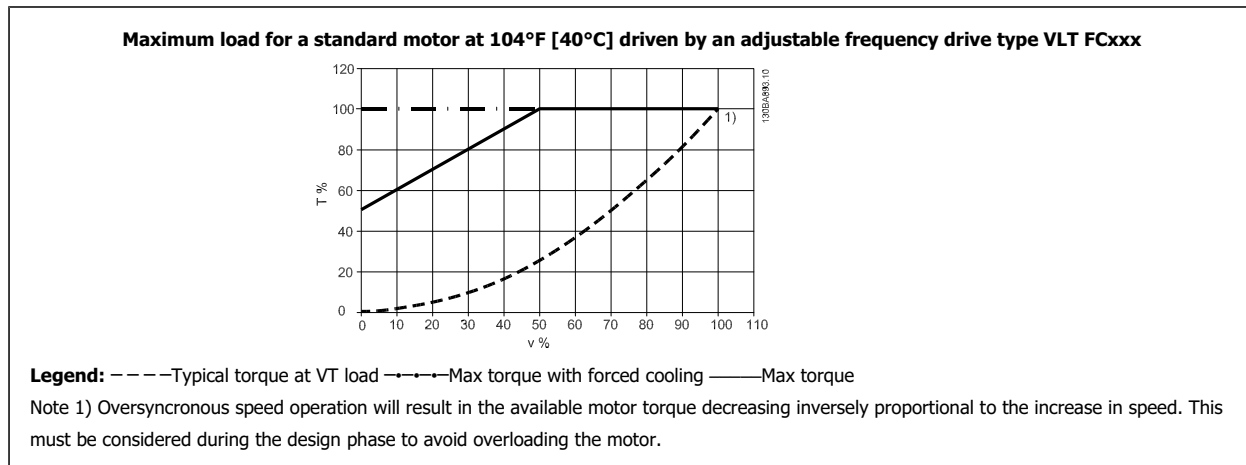
Therefore, if the motor is to be run continuously at an RPM value lower than half of the rated value, the motor must be supplied with additional air-cooling (or a motor designed for this type of operation may be used).

An alternative is to reduce the load level of the motor by choosing a larger motor. However, the design of the adjustable frequency drive limits the motor size.

#### Variable (quadratic) torque applications (VT)

In VT applications such as centrifugal pumps and fans, where the torque is proportional to the square of the speed and the power is proportional to the cube of the speed, there is no need for additional cooling or de-rating of the motor.

In the graphs shown below, the typical VT curve is below the maximum torque with de-rating and maximum torque with forced cooling at all speeds.



10

### 10.2.4 Automatic Adaptations to Ensure Performance

The adjustable frequency drive constantly checks for critical levels of internal temperature, load current, high voltage on the intermediate circuit and low motor speeds. As a response to a critical level, the adjustable frequency drive can adjust the switching frequency and / or change the switching pattern in order to ensure the performance of the adjustable frequency drive. The capability to automatically reduce the output current extends the acceptable operating conditions even further.

## Index

### 0

0-01 Language	8-7
0-20 Display Line 1.1 Small	8-7
0-21 Display Line 1.2 Small	8-10
0-22 Display Line 1.3 Small	8-10
0-23 Display Line 2 Large	8-10
0-24 Display Line 3 Large	8-10

### A

Abbreviations And Standards	3-3
Ac Line Input Connections For A2 And A3	5-4
Ac Line Input Connections For B1, B2 And B3	5-7
Ac Line Input Connections For B4, C1 And C2	5-8
Ac Line Input Connections For C3 And C4	5-8
Access To Control Terminals	5-21
Adj. Freq. Drive Closed-loop	8-64
Adj. Freq. Drive Information	8-59
Adjustable Frequency Drive	5-27
Alarm/warning Code List	9-2
Alarms And Warnings	9-1
Ama	6-3, 7-9
Analog I/o Option Mcb 109	8-72
Analog In/out	8-53
Analog Inputs	10-13
Analog Output	10-13
Application Functions	8-67
Automatic Adaptations To Ensure Performance	10-18
Automatic Motor Adaptation (ama)	5-28, 8-13
Available Literature For Vlt® Aqua Drive	1-2
Awg	10-3

### B

Brake Connection Option	5-16
Brakes	8-49
Bypass Option	8-76

### C

Cable Lengths And Cross-sections	10-12
Cables General	5-1
Can Fieldbus	8-56
Can Motor	6-3
Cascade Controller	8-70
Cascade Ctl Option	8-73
Caution	2-2
Changing A Group Of Numeric Data Values	7-8
Changing A Text Value	7-8
Changing Data	7-8
Changing Of Data Value	7-9
[Check Valve Ramp End Speed Hz] 3-87	8-17
[Check Valve Ramp End Speed Rpm] 3-86	8-16
Check Valve Ramp Time 3-85	8-16
Checklist	4-1
Coasting	7-5
Comm. And Options	8-54
Communication Option	9-5
Configuration Mode 1-00	8-12
Constant Torque Applications (ct Mode)	10-18

Control Cable Clamp	5-22
Control Cables	5-24
Control Cables	5-23
Control Card Performance	10-15
Control Card, 10 V Dc Output	10-15
Control Card, 24 V Dc Output	10-14
Control Card, Rs-485 Serial Communication:	10-13
Control Card, Usb Serial Communication	10-15
Control Characteristics	10-15
Control Terminals	5-22
Cooling	10-18
Cooling Conditions	4-5
Copyright, Limitation Of Liability And Revision Rights	1-2

## D

Data Readouts	8-61
Data Readouts 2	8-63
Dc Bus Connection	5-15
Dc Link	9-4
Default Settings	7-10, 8-44
Derating For Low Air Pressure	10-17
Derating For Running At Low Speed	10-18
Digital In/out	8-52
Digital Inputs:	10-13
Digital Output	10-14
Display Text 1 0-37	8-11
Display Text 2 0-38	8-11
Display Text 3 0-39	8-11
Disposal Instructions	2-3
Drive Closed-loop, 20-**	8-29
Dry Pump Delay 22-27	8-33
Dry Pump Function 22-26	8-33
Dst/summertime 0-74	8-12
Dst/summertime End 0-77	8-12
Dst/summertime Start 0-76	8-12

## E

Efficient Parameter Set-up For Water Applications	6-1
Electrical Installation	5-23
Electrical Wiring	6-3
Electronic Waste	2-3
End Of Curve Delay 22-51	8-36
End Of Curve Function 22-50	8-36
Etr	9-4
Ext. Closed-loop	8-65

## F

Fault Messages	9-4
Filled Setpoint, 29-05	8-43
Final Ramp Time 3-88	8-17
Flow At Rated Speed 22-90	8-39
Flow Compensation 22-80	8-36
Function Relay, 5-40	8-22

## G

General Settings, 1-0*	8-12
General Warning	1-3
Gicp	7-9
Graphical Display	7-1
Grounding And It Line Power	5-1

## H

[High Speed Hz] 22-37	8-34
[High Speed Power Hp] 22-39	8-34
[High Speed Power Kw] 22-38	8-34
[High Speed Rpm] 22-36	8-34
How To Connect A Pc To The Adjustable Frequency Drive	7-11
How To Connect Motor - Introduction	5-8
How To Connect To Line Power And Grounding For B1 And B2	5-7
How To Operate The Graphical Lcp (glcp)	7-1

## I

Indexed Parameters	7-9
Indicator Lights (leds):	7-3
Initial Ramp Time, 3-84	8-16
Initialization	7-10
Installation At High Altitudes	2-1
Intermediate Circuit	9-4

## K

Kty Sensor	9-4
------------	-----

## L

Language Package 1	8-7
Language Package 2	8-7
Language Package 3	8-7
Language Package 4	8-7
Lcp	7-9
Lcp 102	7-1
Leakage Current	2-2
Leds	7-1
Limits / Warnings	8-51
Line Power Supply	10-3, 10-9, 10-10
Line Power Supply (L1, L2, L3)	10-12
Line Power Supply 1 X 200-240 V Ac	10-2
Line Power Wiring Overview	5-3
Live Zero Timeout Function 6-01	8-25
Live Zero Timeout Time 6-00	8-24
Load/motor	8-47
Low Power Auto Set-up 22-20	8-32
Low Power Detection 22-21	8-32
Low Speed Detection 22-22	8-32
[Low Speed Hz] 22-33	8-34
[Low Speed Power Hp] 22-35	8-34
[Low Speed Power Kw] 22-34	8-34
[Low Speed Rpm] 22-32	8-33

## M

Main Menu	8-1
Main Menu Mode	7-4
Main Menu Mode	8-5
Main Reactance	8-14
Maximum Boost Time 22-46	8-35
Maximum Reference 3-03	8-15
Mct 10	7-12
Mechanical Dimensions	4-4
Mechanical Mounting	4-5
Minimum Reference 3-02	8-14
Minimum Run Time 22-40	8-34



Minimum Sleep Time 22-41	8-35
Motor Connection For C3 And C4	5-14
Motor Current 1-24	8-13
Motor Frequency 1-23	8-13
Motor Nameplate	5-27
Motor Nominal Speed 1-25	8-13
Motor Output	10-12
[Motor Power Kw] 1-20	8-13
Motor Protection	10-12
[Motor Speed High Limit Rpm] 4-13	8-17
[Motor Speed Low Limit Rpm] 4-11	8-17
Motor Voltage 1-22	8-13
Motor Wiring Overview	5-10

## N

Nameplate Data	5-28
Nameplate Data.	5-27
Nlcp	7-5
No-flow Delay 22-24	8-33
No-flow Function 22-23	8-33
No-flow Power 22-30	8-33

## O

Occurrence 23-04	8-42
Off Action 23-03	8-41
Off Time 23-02	8-41
On Action 23-01	8-39
On Time 23-00	8-39
Operation/display	8-45
Output Performance (u, V, W)	10-12

## P

Panel Through Mounting	4-6
Parameter Options	8-44
Parameter Selection	8-6
Parameter Set-up	8-1
Pc Software Tools	7-12
Pid Integral Time 20-94	8-31
Pid Normal/inverse Control, 20-81	8-31
Pid Proportional Gain 20-93	8-31
[Pid Start Speed Rpm] 20-82	8-31
Pipe Fill Enable, 29-00	8-42
Pipe Fill Rate, 29-04	8-43
[Pipe Fill Speed Hz], 29-02	8-43
[Pipe Fill Speed Rpm], 29-01	8-42
Pipe Fill Time, 29-03	8-43
Power Correction Factor 22-31	8-33
Preset Reference 3-10	8-15
Pressure At No-flow Speed 22-87	8-38
Pressure At Rated Speed 22-88	8-38
Profibus	8-55
Profibus Dp-v1	7-12
Protection And Features	10-11
Pulse Inputs	10-14

## Q

Q1 My Personal Menu	8-2
Q2 Quick Set-up	8-2
Q3 Function Set-ups	8-3
Q5 Changes Made	8-4

Q6 Loggings	8-5
Quick Menu	6-1, 7-3, 8-1
Quick Menu Mode	7-4
Quick Transfer Of Parameter Settings When Using Glcp	7-9

## R

Ramp 1 Ramp-down Time 3-42	8-15
Ramp 1 Ramp-up Time 3-41	8-15
Reference / Ramps	8-50
Reference/feedback Unit, 20-12	8-29
Relay Connection	5-17
Relay Output	5-20
Relay Outputs	10-14
Reset	7-5
Residual Current Device	2-2
Rs-485 Bus Connection	7-11

## S

Safety Note	2-1
Safety Requirements For Mechanical Installation	4-6
Serial Communication	10-15
Set Date And Time, 0-70	8-11
Setpoint 1 20-21	8-30
Setpoint Boost 22-45	8-35
Shielded/armored.	5-24
Side-by-side Installation	4-5
Sine-wave Filter	5-9
Sine-wave Filter	6-3
Smart Logic	8-57
Software Version	1-1
Special Functions	8-58
[Speed At Design Point Hz] 22-86	8-38
[Speed At Design Point Rpm] 22-85	8-38
[Speed At No-flow Hz] 22-84	8-38
[Speed At No-flow Rpm] 22-83	8-38
Square-linear Curve Approximation 22-81	8-36
Start/stop	6-2
Stator Leakage Reactance	8-14
Status	7-3
Status Messages	7-1
Step-by-step	7-9
Submersible Pump	6-3
Surroundings	10-15
Switches S201, S202, And S801	5-27

## T

Term. 29 High Ref./feedb. Value 5-53	8-24
Terminal 27 Mode 5-01	8-18
Terminal 42 Output 6-50	8-26
Terminal 42 Output Max Scale 6-52	8-28
Terminal 42 Output Min Scale 6-51	8-27
Terminal 53 High Ref./feedb. Value 6-15	8-26
Terminal 53 High Voltage 6-11	8-25
Terminal 53 Low Ref./feedb. Value 6-14	8-26
Terminal 53 Low Voltage 6-10	8-25
Terminal 54 High Ref./feedb. Value 6-25	8-26
Terminal 54 High Voltage 6-21	8-26
Terminal 54 Low Ref./feedb. Value 6-24	8-26
Terminal 54 Low Voltage 6-20	8-26
Tightening Of Terminals	5-1
Time Format 0-72	8-12

Timed Actions	8-39, 8-69
Torque Characteristics	10-12
Type Code String - Medium Power	3-1
Type Code String (t/c)	3-3

## U

Unpacking Table	4-1
Usb Connection	5-22

## V

Variable (quadratic) Torque Applications (vt)	10-18
Voltage Level	10-13

## W

Wake-up Ref./fb Difference 22-44	8-35
[Wake-up Speed Hz] 22-43	8-35
[Wake-up Speed Rpm] 22-42	8-35
Warning Against Unintended Start	2-1
Water Application Functions	8-75
Water Application Functions, 29-**	8-42
Wiring Example And Testing	5-20
Work Point Calculation 22-82	8-37



[www.danfoss.com/drives](http://www.danfoss.com/drives)

Danfoss shall not be responsible for any errors in catalogs, brochures or other printed material. Danfoss reserves the right to alter its products at any time without notice, provided that alterations to products already on order shall not require material changes in specifications previously agreed upon by Danfoss and the Purchaser. All trademarks in this material are property of the respective companies. Danfoss and the Danfoss logotype are trademarks of Danfoss A/S. All rights reserved.

### **Danfoss Drives**

4401 N. Bell School Rd.  
Loves Park IL 61111 USA  
Phone: 1-800-432-6367  
1-815-639-8600  
Fax: 1-815-639-8000  
[www.danfossdrives.com](http://www.danfossdrives.com)

### **Danfoss Drives**

8800 W. Bradley Rd.  
Milwaukee, WI 53224 USA  
Phone: 1-800-621-8806  
1-414-355-8800  
Fax: 1-414-355-6117  
[www.danfossdrives.com](http://www.danfossdrives.com)

