

# SIEMENS

## SITOP power supply

### SITOP PSU300M/300B

#### Manual

SITOP PSU300M 24 V/20 A  
6EP1436-3BA10  
SITOP PSU300M 48 V/10 A  
6EP1456-3BA00  
SITOP PSU300B 12 V/20 A  
6EP1424-3BA00  
SITOP PSU300B 24 V/17 A  
6EP1436-3BA20  
SITOP PSU300B 24 V/30 A  
6EP1437-3BA20

11.2014

C98130-A7574-A2-2-7629

#### Overview

---

Safety notes

1

Description, device design,  
dimension drawing

2

Mounting/disassembly

3

Mounting position, mounting  
clearances

4

Installation

5

Technical data

6

Safety, approvals, EMC

7

Ambient conditions

8

Applications

9

Environment

10



Service & Support

11

## Legal information

### Warning notice system

This manual contains notices you have to observe in order to ensure your personal safety, as well as to prevent damage to property. The notices referring to your personal safety are highlighted in the manual by a safety alert symbol, notices referring only to property damage have no safety alert symbol. These notices shown below are graded according to the degree of danger.

 <b>DANGER</b>
indicates that death or severe personal injury <b>will</b> result if proper precautions are not taken.
 <b>WARNING</b>
indicates that death or severe personal injury <b>may</b> result if proper precautions are not taken.
 <b>CAUTION</b>
indicates that minor personal injury can result if proper precautions are not taken.
<b>NOTICE</b>
indicates that property damage can result if proper precautions are not taken.

If more than one degree of danger is present, the warning notice representing the highest degree of danger will be used. A notice warning of injury to persons with a safety alert symbol may also include a warning relating to property damage.

### Qualified Personnel

The product/system described in this documentation may be operated only by **personnel qualified** for the specific task in accordance with the relevant documentation, in particular its warning notices and safety instructions. Qualified personnel are those who, based on their training and experience, are capable of identifying risks and avoiding potential hazards when working with these products/systems.

### Proper use of Siemens products

Note the following:

 <b>WARNING</b>
Siemens products may only be used for the applications described in the catalog and in the relevant technical documentation. If products and components from other manufacturers are used, these must be recommended or approved by Siemens. Proper transport, storage, installation, assembly, commissioning, operation and maintenance are required to ensure that the products operate safely and without any problems. The permissible ambient conditions must be complied with. The information in the relevant documentation must be observed.

### Trademarks

All names identified by ® are registered trademarks of Siemens AG. The remaining trademarks in this publication may be trademarks whose use by third parties for their own purposes could violate the rights of the owner.

### Disclaimer of Liability

We have reviewed the contents of this publication to ensure consistency with the hardware and software described. Since variance cannot be precluded entirely, we cannot guarantee full consistency. However, the information in this publication is reviewed regularly and any necessary corrections are included in subsequent editions.

# Overview



The 3-phase power supply from the SITOP PSU300M/300B is a powerful, stabilized technology power supply for automated machines and systems.

The key benefits of the product include:

- 3-phase 320 to 575 VAC wide-range input
- Power boost during operation 300% for 25 ms (only PSU300M and PSU300B 12 V/20 A)
- No lateral mounting clearances are required
- 150% extra power when loads with high input current are switched on (PSU300M and PSU300B 12 V/20 A only)
- Ambient temperature -25 (-10)...+70 °C
- 48 V / 10 A permits small cable cross-sections
- Selectable short-circuit behavior
- Soft characteristic curve for parallel switching or battery charging can be selected
- Display of the operating state using 3 LEDs
- Integrated signaling contact "DC 12 V O.K." / "DC 24 V O.K." / "DC 48 V O.K."
- The properties of the PSU300B power supplies makes them ideal for battery charging
- To increase the system availability, some reliable power supplies can be expanded using SITOP supplementary modules (redundancy module, selectivity module, buffer module), as well as SITOP DC-UPS modules.

## Ordering data

The following device versions are available:

Regulated SITOP PSU300M/300B power supply	
Type	Order number
3-phase 400-500 V AC input, Output 24 V DC / 20 A	6EP1436-3BA10
3-phase 400-500 V AC input, Output 48 V DC / 10 A	6EP1456-3BA00
3-phase 400-500 V AC input, Output 12 V DC / 20 A	6EP1424-3BA00
3-phase 400-500 V AC input, Output 24 V DC / 17 A	6EP1436-3BA20
3-phase 400-500 V AC input, Output 24 V DC / 30 A	6EP1437-3BA20

Accessories	
Type	Order number
Device identification labels 20 mm × 7 mm, pastel turquoise	3RT1900-1SB20

# Table of contents

	<b>Overview</b> .....	<b>3</b>
<b>1</b>	<b>Safety notes</b> .....	<b>7</b>
<b>2</b>	<b>Description, device design, dimension drawing</b> .....	<b>9</b>
2.1	Device description.....	9
2.2	Connections and terminal designation.....	10
2.3	Potentiometer.....	11
2.4	Status displays and signaling.....	12
2.5	Change-over switch.....	15
2.6	Block diagram.....	16
2.7	Dimensions and weight.....	17
<b>3</b>	<b>Mounting/disassembly</b> .....	<b>19</b>
<b>4</b>	<b>Mounting position, mounting clearances</b> .....	<b>21</b>
4.1	Standard mounting position.....	21
4.2	Other mounting positions.....	24
4.2.1	6EP1436-3BA10.....	24
4.2.2	6EP1456-3BA00.....	26
4.2.3	6EP1424-3BA00.....	28
4.2.4	6EP1436-3BA20.....	30
4.2.5	6EP1437-3BA20.....	32
<b>5</b>	<b>Installation</b> .....	<b>35</b>
5.1	Line-side connection.....	35
5.2	Output-side connection.....	37
<b>6</b>	<b>Technical data</b> .....	<b>39</b>
6.1	Input.....	39
6.2	Output.....	41
6.3	Efficiency.....	50
6.4	Closed-loop control.....	53
6.5	Protection and monitoring.....	54
6.6	MTBF.....	55
6.7	Mechanical system.....	55
6.8	Accessories.....	57
6.9	Dimension drawing.....	57

<b>7</b>	<b>Safety, approvals, EMC .....</b>	<b>59</b>
7.1	Safety .....	59
7.2	Test voltage.....	60
7.3	Approvals .....	61
7.4	EMC .....	61
<b>8</b>	<b>Ambient conditions.....</b>	<b>63</b>
<b>9</b>	<b>Applications .....</b>	<b>65</b>
9.1	Parallel connection to increase power rating .....	65
9.2	Parallel connection for redundancy .....	67
9.3	Series connection for increased voltage.....	69
9.4	Overload protection in the 24 V output circuit.....	70
9.5	Protection against short-time voltage dips.....	71
9.6	Protecting against longer power failures.....	72
9.7	Battery charging with SITOP PSU300B.....	74
<b>10</b>	<b>Environment .....</b>	<b>77</b>
<b>11</b>	<b>Service &amp; Support.....</b>	<b>79</b>

 **WARNING**

**Correct handling of the devices**

When operating electrical devices, it is inevitable that certain components will carry dangerous voltages.

Therefore, failure to handle the units properly can result in death or serious physical injury as well as extensive property damage.

Only appropriately qualified personnel may work on or in the vicinity of this equipment.

Perfect, safe, and reliable operation of this equipment is dependent on proper transportation, storage, installation and mounting.

Before installation or maintenance work can begin, the system's main switch must be switched off and measures taken to prevent it being switched on again.

If this instruction is not observed, touching live parts can result in death or serious injury.





## Description, device design, dimension drawing

### 2.1 Device description

SITOP PSU300M/300B is a primary-clocked power supply for connection to a 3-phase AC line supply. An electronically regulated DC voltage that can be set via a potentiometer is available at the output of the device. The output of the device is isolated, no-load proof and short-circuit proof. The LED displays indicate the operating state. The operating state of the device can be processed via the signaling contact. The PSU300B devices are optimized to charge batteries.

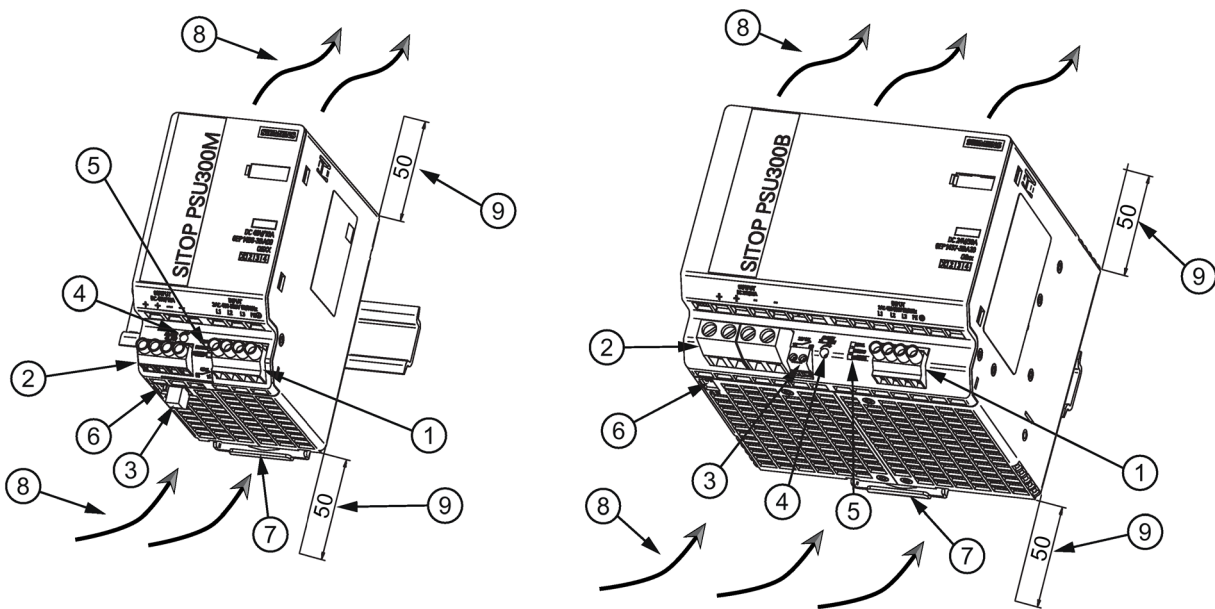



- ① Line input
- ② DC output
- ③ Signaling contacts
- ④ Potentiometer 12 ... 14 V, 24 ... 28.8 V, 42 ... 56 V
- ⑤ Pilot lamps (12/24/48 V OK, OVERLOAD, SHUT DOWN)
- ⑥ Selector switch
- ⑦ DIN rail slider
- ⑧ Convection
- ⑨ Clearance above/below

Figure 2-1 Design

## 2.2 Connections and terminal designation

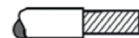
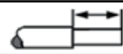

The line input terminals ① can be used to establish the connection to the supply voltage. The output terminals ② are used to connect to the loads to be supplied (see also Section Installation (Page 35)).

Connections and terminal designations	
① Line input L1, L2, L3, PE	One screw terminal each
② output "+"	2 screw terminals
② output "-"	2 screw terminals
③ signaling contacts 13, 14	One screw terminal each

	① + ②	③	④
	SZS 0,6 x 3,5 / PZ1 / PH1	SZS 0,6 x 3,5	SZS 0,6 x 3 / PZ1 / PH1 max. Ø 3,5 mm
	1 x 0,2 - 6 mm <sup>2</sup>	1 x 0,14 - 1,5 mm <sup>2</sup>	-
	1 x 0,2 - 4 mm <sup>2</sup>	1 x 0,14 - 1,5 mm <sup>2</sup>	-
AWG	26 - 10	28 - 16	-
Nm	0,5 - 0,6 Nm	0,22 Nm	0,04 Nm <sup>*1)</sup>
	8 mm	7 mm	-

<sup>\*1)</sup> Do not subject the end stop to higher loads

Figure 2-2 Terminal data for 6EP1436-3BA10, 6EP1456-3BA00, 6EP1424-3BA00, 6EP1436-3BA20

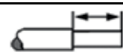
	①	②	③	④
	SZS 0,6 x 3,5 / PZ1 / PH1	SZS 1,0 x 5,5	SZS 0,6 x 3,5	SZS 0,4 x 2,5 / max. Ø 3,5 mm
	1 x 0,2 - 6 mm <sup>2</sup>	1 x 0,5 - 16 mm <sup>2</sup>	1 x 0,14 - 4,0 mm <sup>2</sup>	-
	1 x 0,2 - 4 mm <sup>2</sup>	1 x 0,5 - 10 mm <sup>2</sup>	1 x 0,14 - 2,5 mm <sup>2</sup>	-
AWG	26 - 10	26 - 6	22 - 12	-
Nm	0,5 - 0,6 Nm	1,2 - 1,5 Nm	0,5 - 0,6 Nm	0,04 Nm <sup>*1)</sup>
	8 mm	12 mm	7 mm	-

<sup>\*1)</sup> Do not subject the end stop to higher loads

Figure 2-3 Terminal data for 6EP1437-3BA20

## 2.3 Potentiometer

The potentiometer ④ on the front of the device is used to adjust the output voltage. The output voltage is set to 12 V, 24 V or 48 V in the factory, and can be adjusted in the range 12 ... 14 V, 24 ... 28.8 V or 42 ... 56 V; for example, to compensate voltage drops across long supply lines to the connected load.

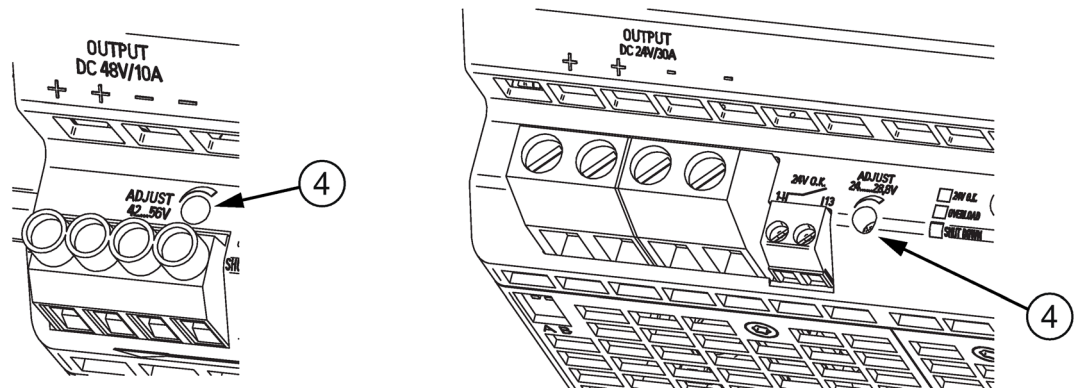

Figure 2-4 Potentiometer (example 6EP1456-3BA00 / 6EP1437-3BA20)

### NOTICE

#### Thermal overload possible

When adjusting the output voltage to  $>24\text{ V}$  ( $>48\text{ V}$ ), the output current must be derated by 4 %/V or the permissible ambient temperature must be taken into account with 3 K/V (applies to PSU300M devices).

### Note

It is only permissible to use an insulated screwdriver when actuating the potentiometer.

For notes on actuating the potentiometer (screwdriver, torque), see Figure 2-2 Terminal data for 6EP1436-3BA10, 6EP1456-3BA00, 6EP1424-3BA00, 6EP1436-3BA20 (Page 10) and Figure 2-3 Terminal data for 6EP1437-3BA20 (Page 10).

## 2.4 Status displays and signaling

	6EP1436-3BA10 (24 V / 20 A)	6EP1456-3BA00 (48 V/10 A)
Operating display	LED green for "24 V O.K." Yellow LED for "overload" Red LED for "latching shutdown"	LED green for "48 V O.K." Yellow LED for "overload" Red LED for "latching shutdown"
Signaling contact	Relay contact (NO contact, rating 60 V DC / 0.3 A) for "24 V O.K."	Relay contact (NO contact, rating 60 V DC / 0.3 A) for "48 V O.K."

	6EP1424-3BA00 (12 V/20 A)	6EP1436-3BA20 (24 V/17 A) 6EP1437-3BA20 (24 V / 30 A)
Operating display	LED green for "12 V O.K." Yellow LED for "overload" Red LED for "latching shutdown"	LED green for "24 V O.K." Yellow LED for "overload" Red LED for "latching shutdown"
Signaling contact	Relay contact (NO contact, rating 60 V DC / 0.3 A) for "12 V O.K."	Relay contact (NO contact, rating 60 V DC / 0.3 A) for "24 V O.K."

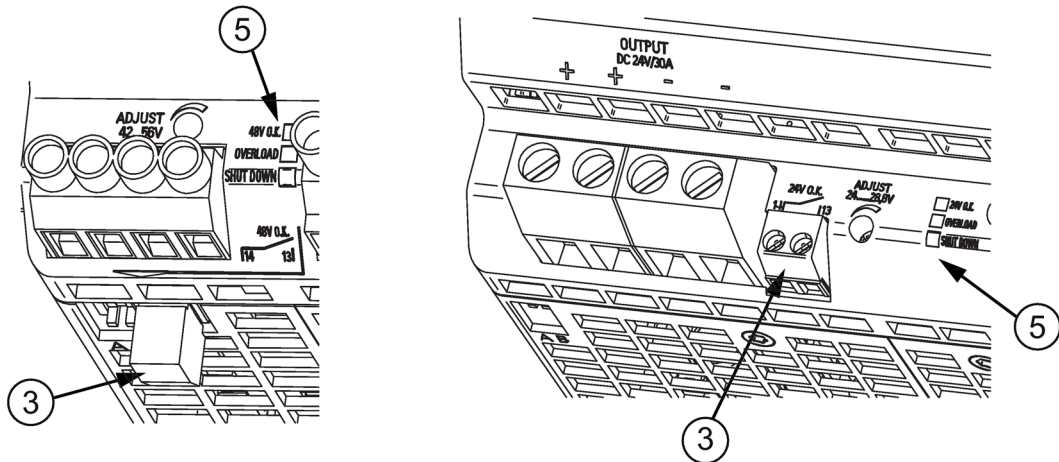

Figure 2-5 Operating display and signaling (example 6EP1456-3BA00 / 6EP1437-3BA20)

Signaling	6EP1436-3BA10 (24 V / 20 A)	6EP1456-3BA00 (48 V/10 A)
Green LED ⑤ lit Signaling contact ③, contacts 13-14 closed	Normal operation, output voltage > 20.5 V	Normal operation, output voltage > 41 V
LED ⑤ off Signaling contact ③, contacts 13-14 open (quiescent position)	No supply voltage	No supply voltage

<b>Signaling</b>	<b>6EP1436-3BA10 (24 V / 20 A)</b>	<b>6EP1456-3BA00 (48 V/10 A)</b>	
Yellow LED ⑤ lit Signaling contact ③, contacts 13-14 open (quiescent position)	Overload, output voltage < 20.5 V (only in "constant current" mode)	Overload, output voltage < 41 V (only in "constant current" mode)	
Yellow and green LED lights Signaling contact ③, contacts 13-14 closed	Phase failure, output voltage O.K.	Phase failure, output voltage O.K.	
Red LED ④ lit Signaling contact ③, contacts 13-14 open (quiescent position)	Latching shutdown (only in "Shutdown" mode)	Latching shutdown (only in "Shutdown" mode)	
Red LED ④ flashes Signaling contact ③, contacts 13-14 open (quiescent position)	Overtemperature → power OFF/ON after 3 min	Overtemperature → power OFF/ON after 3 min	
<b>Signaling</b>	<b>6EP1424-3BA00 (12 V / 20 A)</b>	<b>6EP1436-3BA20 (24 V / 17 A)</b>	<b>6EP1437-3BA20 (24 V / 30 A)</b>
Green LED ⑤ lit Signaling contact ③, contacts 13-14 closed	Normal operation Output voltage > 10.0 V	Normal operation, output voltage > 20.5 V	Normal operation, output voltage > 20.5 V
LED ⑤ off Signaling contact ③, contacts 13-14 open (quiescent position)	No supply voltage	No supply voltage	No supply voltage
Yellow LED ⑤ lit Signaling contact ③, contacts 13-14 open (quiescent position)	Overload, output voltage < 10.0 V (only in "constant current")	Overload, output voltage < 20.5 V (only in "constant current" mode)	Overload, output voltage < 20.5 V (only in "constant current" mode)
Yellow and green LED lights Signaling contact ③, contacts 13-14 open (quiescent position)	Phase failure, output voltage O.K.	Phase failure, output voltage O.K.	-

2.4 Status displays and signaling

Signaling	6EP1424-3BA00 (12 V / 20 A)	6EP1436-3BA20 (24 V / 17 A)	6EP1437-3BA20 (24 V / 30 A)
Red LED ④ lit Signaling contact ③, contacts 13-14 open (quiescent position)	Latching shutdown (only in "Shutdown" mode)	Latching shutdown (only in "Shutdown" mode)	Latching shutdown (only in "Shutdown" mode)
Red LED ④ flashes Signaling contact ③, contacts 13-14 closed	Overtemperature → power OFF/ON after 3 minutes	Overtemperature → power OFF/ON after 3 minutes	Overtemperature → power OFF/ON after 3 minutes

## 2.5 Change-over switch

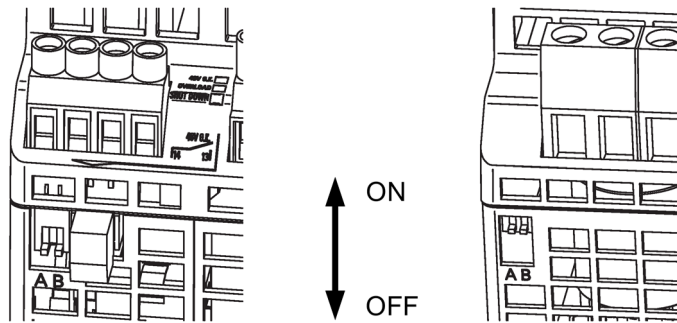

Figure 2-6 Selector switch (example 6EP1456-3BA00 / 6EP1437-3BA20)

The two switches A and B are used to influence the output characteristic curve:

Switch	ON	OFF
<b>A</b> influences the output characteristic in the load range	<b>Parallel operation:</b> 'Soft' characteristic curve (see, e.g. Figure 6-8 6EP1436-3BA10 parallel operation output characteristic curve (Page 46)) for the parallel operation of two or more devices: The output voltage falls with increasing output current (namely, also for the overcurrent pulse!). This means that for full output current the highest output voltage can normally no longer be attained.	<b>Single operation:</b> <i>Delivery state</i> 'Hard' characteristic curve (see, e.g. Figure 6-3 6EP1436-3BA10 single operation output characteristic curve (Page 44)) for normal operation (single operation): The output voltage is independent of the output current.
<b>B</b> influences the output characteristic in the overload range	<b>Latching shutdown:</b> If the output current rises above the rated value and above the current limit, the device reduces the output voltage (see, e.g. Figure 6-13 6EP1436-3BA10 latching shutdown output characteristic curve (Page 48)). If the output voltage falls below (10 V), (20 V), (40 V), the device shuts down latching, the red LED lights. This limit voltage of (10 V), (20 V), (40 V) is independent of the set output voltage. The 'Short-time overload current' feature is not available in this operating mode. In order to also be able to charge large capacitances in this operating mode at the output, non-latching shutdown is performed during the first ten seconds after power on. During these first 10 s, the device responds for overload as if the switch is OFF.	<b>Constant current:</b> <i>Delivery state</i> If the output current rises above the rated value and above the current limit, the device reduces the output voltage. The yellow LED lights if the output voltage falls below (10 V), (20 V), (40 V).

Delivery state: A-OFF; B-OFF

2.6 Block diagram

## 2.6 Block diagram

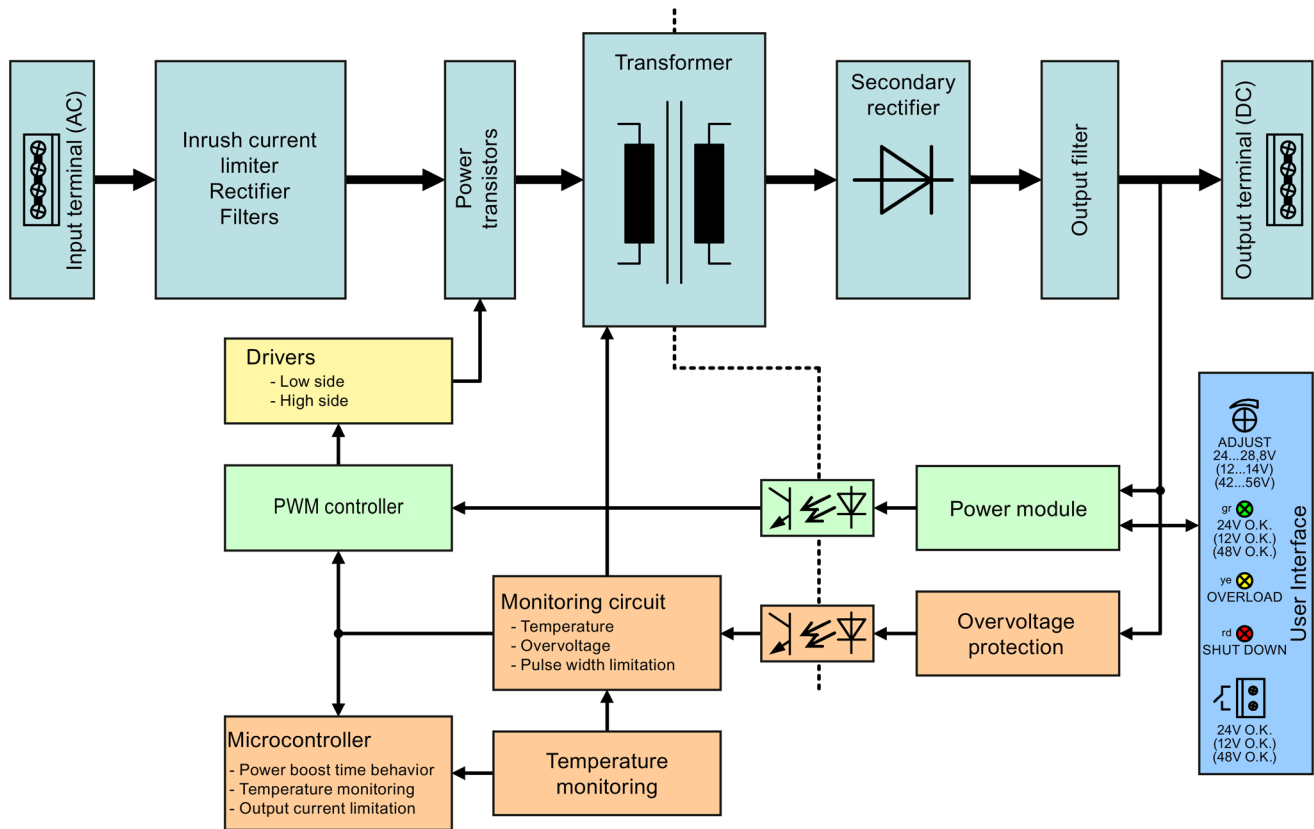

Figure 2-7 Block diagram



## 2.7 Dimensions and weight

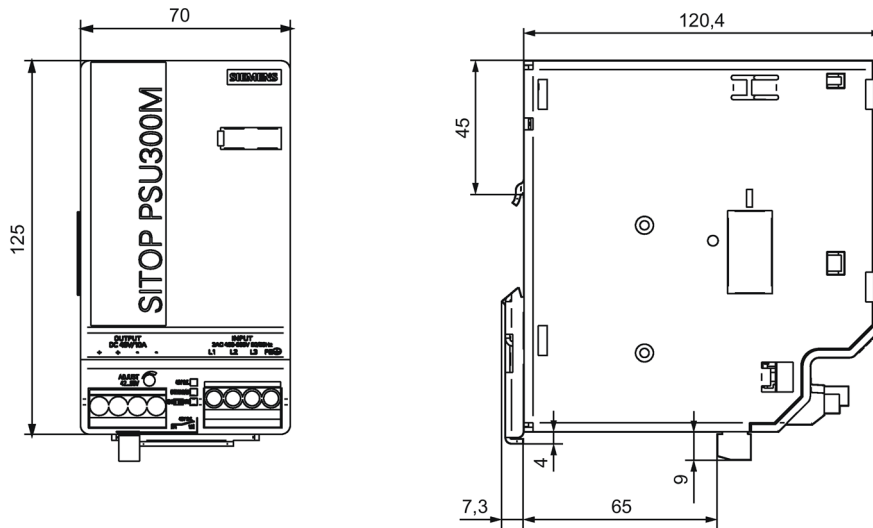

Figure 2-8 6EP1424-3BA00, 6EP1436-3BA20, 6EP1436-3BA10, 6EP1456-3BA00 dimensioned drawing

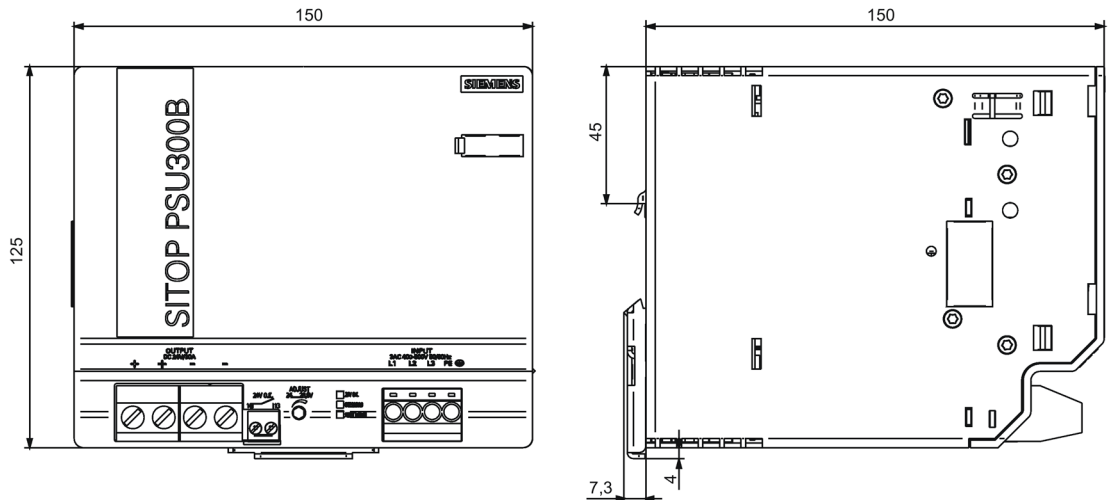

Figure 2-9 Dimension drawing 6EP1437-3BA20

	6EP1424-3BA00 (12 V / 20 A) 6EP1436-3BA20 (24 V / 17 A) 6EP1436-3BA10 (24 V / 20 A) 6EP1456-3BA00 (48 V / 10 A)	6EP1437-3BA20 (24 V / 30 A)
Dimensions (W × H × D) in mm	70 × 125 × 125	150 × 125 × 150
Weight	approx. 1.2 kg	approx. 3.4 kg



## Mounting/disassembly

### WARNING

#### Installing the device in a housing or a control cabinet

The SITOP PSU300M/300B power supply is a built-in device. It must be installed in a housing or control cabinet, to which only qualified personnel have access.

The device can be mounted in a control cabinet on standard mounting rails according to EN 60715.

#### Mounting

To mount the device, position it with the mounting rail guide at the upper edge of the standard mounting rail and press down to lock it into place. If this is too difficult, press slider ① at the same time, as described under "Removal".

#### Removal

To remove, pull up the slider ① using a screwdriver ② and disengage the device at the bottom edge of the standard mounting rail. Then you can remove the device from the upper edge of the standard mounting rail.

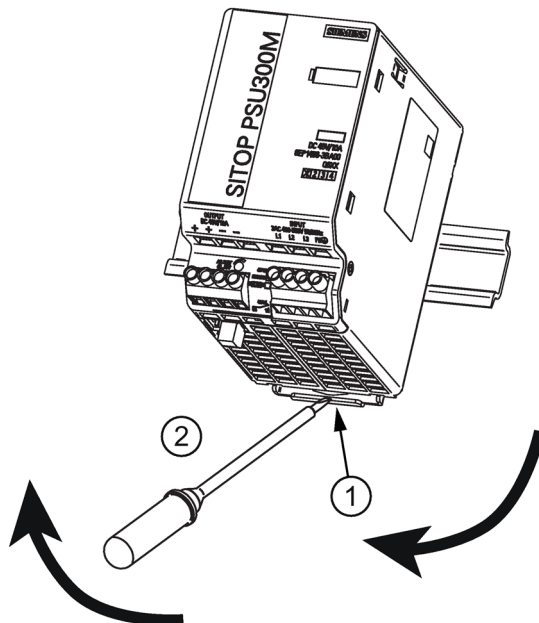

Figure 3-1 Mounting/removal (example 6EP1456-3BA00)

 **WARNING**

**Use in hazardous zones**

If the devices are to be used in hazardous zones (Ex II 3G Ex nA nC IIC T4) they must be installed in a distribution box with degree of protection IP54 or higher.

## Mounting position, mounting clearances

### 4.1 Standard mounting position

The device is mounted on standard mounting rails according to EN 60715. The device must be mounted vertically in such a way that the input terminals and the output terminals are at the bottom to ensure correct cooling.

A clearance of at least 50 mm should be maintained above and below the device (maximum depth of the cable duct, 50 mm).

No space is required at the side.

### Output current as a function of the ambient temperature and mounting height

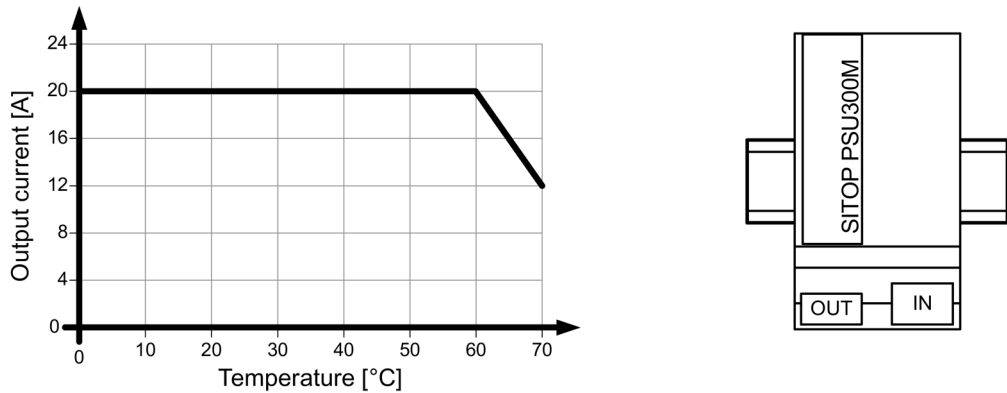

Figure 4-1 6EP1436-3BA10: Output current in the standard mounting position

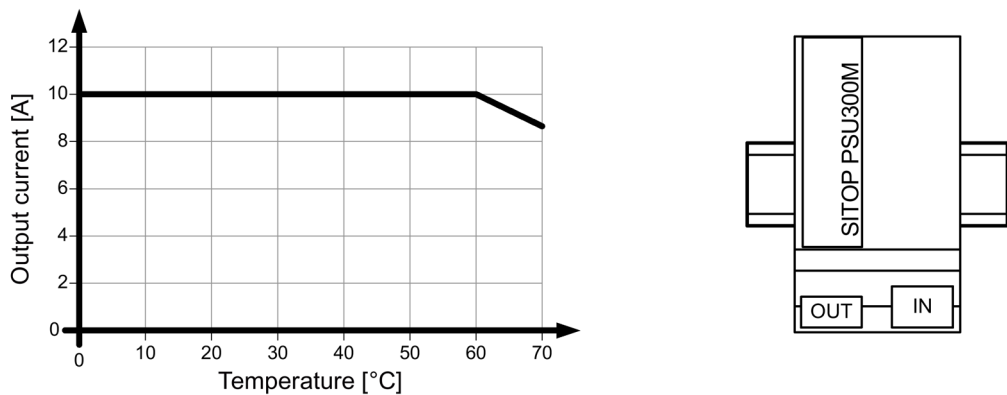

Figure 4-2 6EP1456-3BA00: Output current in the standard mounting position

4.1 Standard mounting position

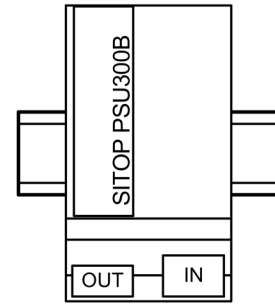
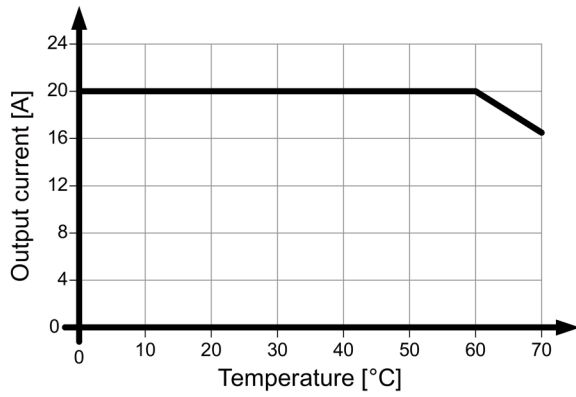

Figure 4-3 6EP1424-3BA00: Output current in the standard mounting position

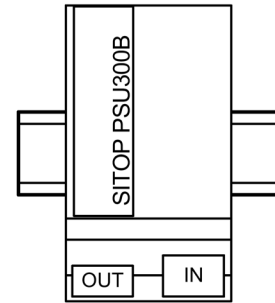
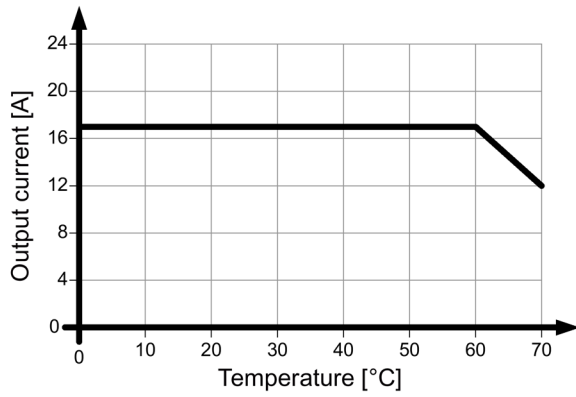

Figure 4-4 6EP1436-3BA20: Output current in the standard mounting position

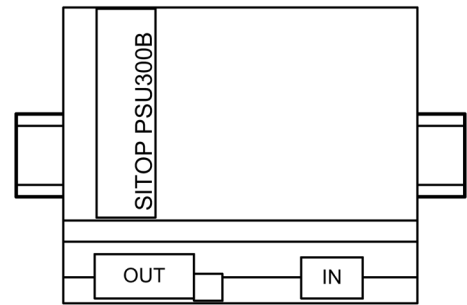
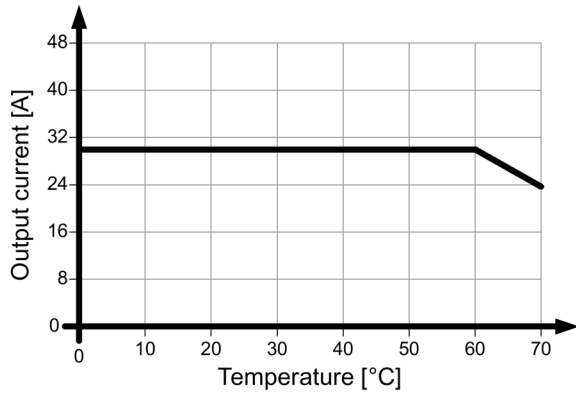

Figure 4-5 6EP1437-3BA20: Output current in the standard mounting position

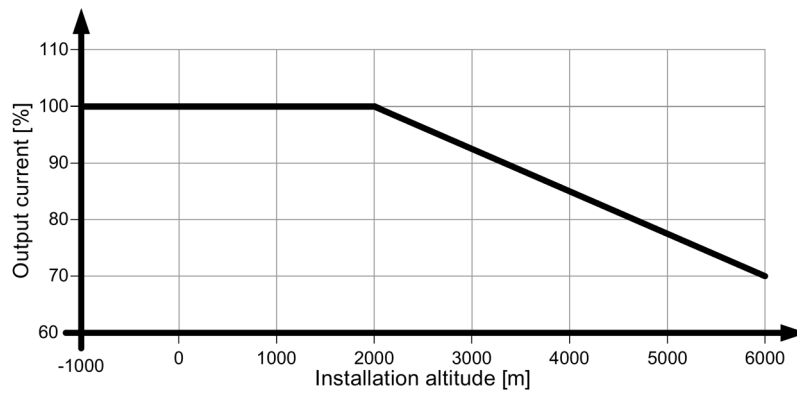

Figure 4-6 Mounting height derating

## 4.2 Other mounting positions

For mounting positions that deviate from the standard mounting position, derating factors (reduction of the output power or the permissible ambient temperature) must be observed in accordance with the following diagrams.

### Note

In the case of mounting positions that deviate from the standard mounting position, reduced mechanical resistance of the devices against vibration and shock must be expected.

Particularly when installing on a vertically fastened standard mounting rail, additional measures may be required, e.g. to prevent the device from slipping on the standard mounting rail.

### 4.2.1 6EP1436-3BA10

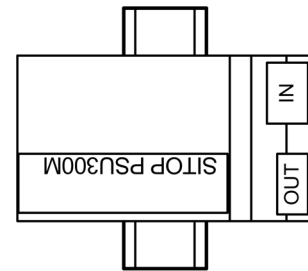
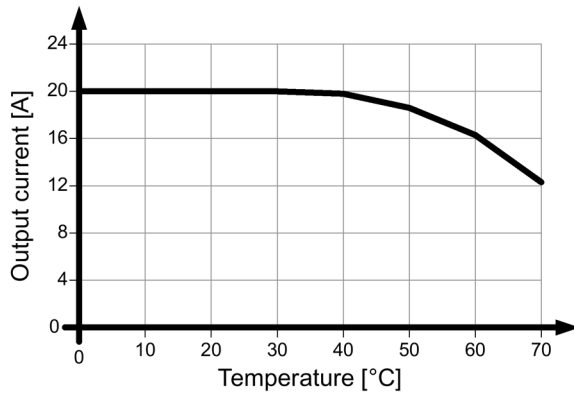

Figure 4-7 6EP1436-3BA10 mounting position (1)

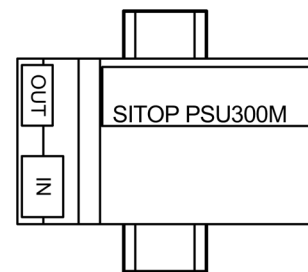
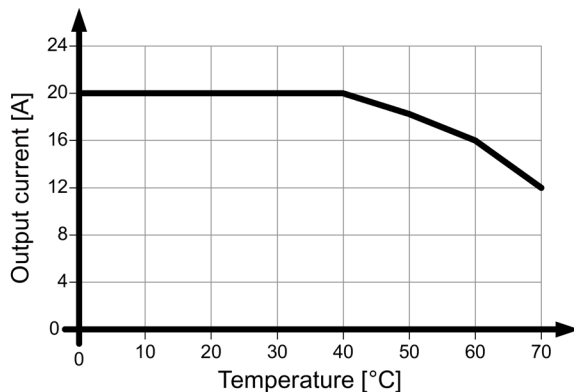

Figure 4-8 6EP1436-3BA10 mounting position (2)



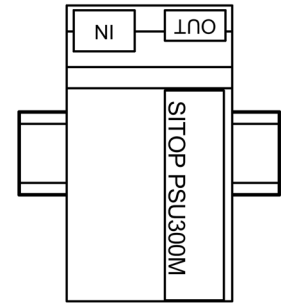
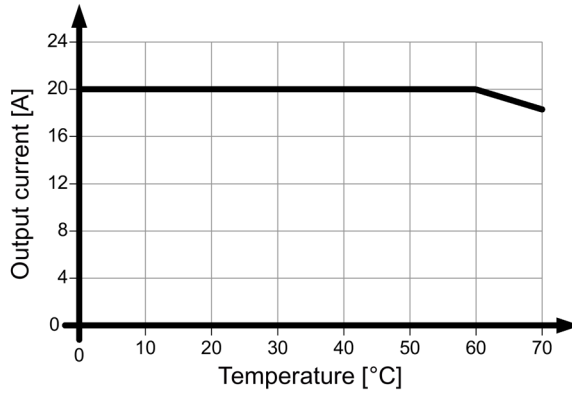

Figure 4-9 6EP1436-3BA10 mounting position (3)

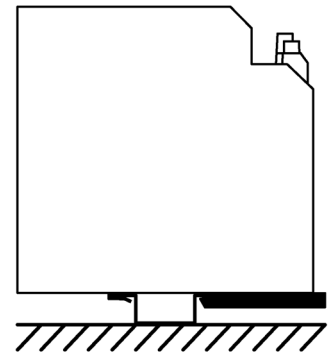
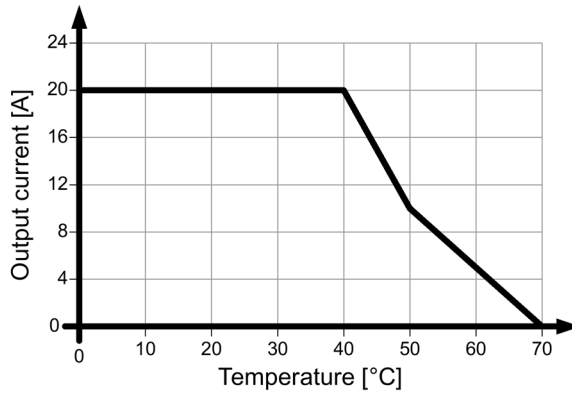

Figure 4-10 6EP1436-3BA10 mounting position (4)

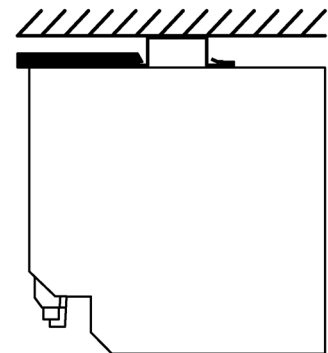
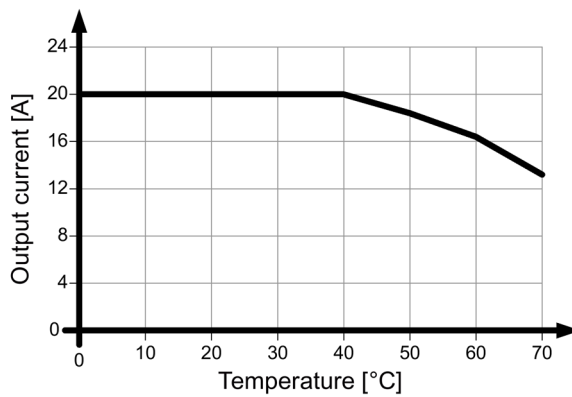

Figure 4-11 6EP1436-3BA10 mounting position (5)

4.2.2 6EP1456-3BA00

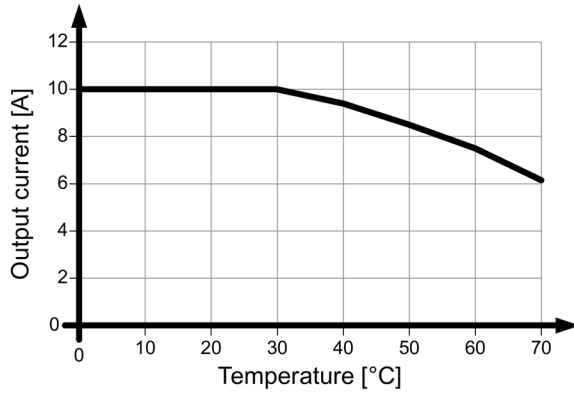

Figure 4-12 6EP1456-3BA00 mounting position (1)

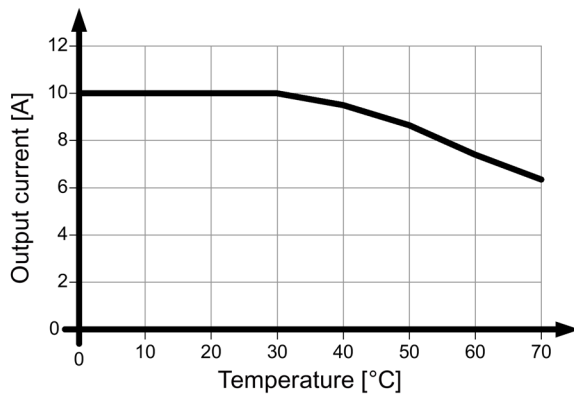
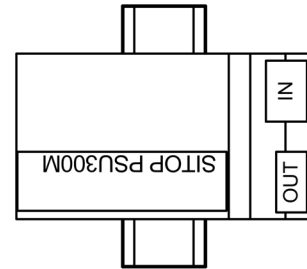

Figure 4-13 6EP1456-3BA00 mounting position (2)

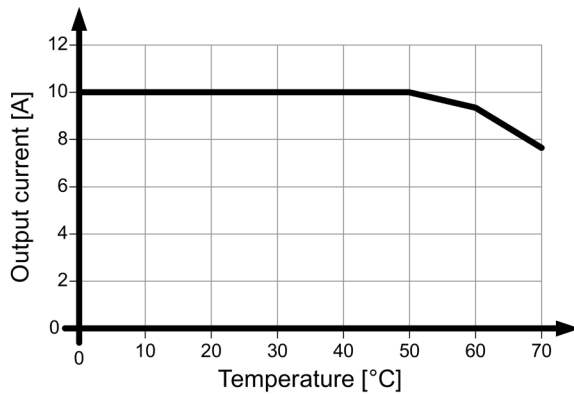
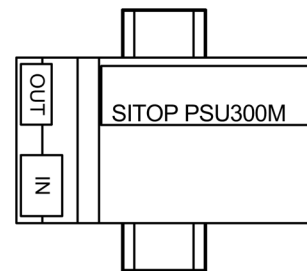
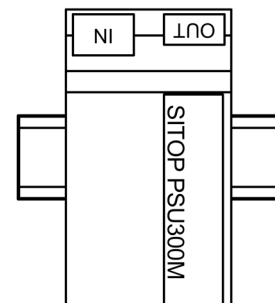

Figure 4-14 6EP1456-3BA00 mounting position (3)



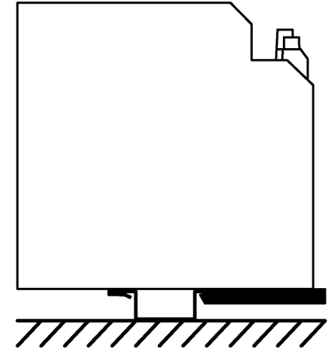
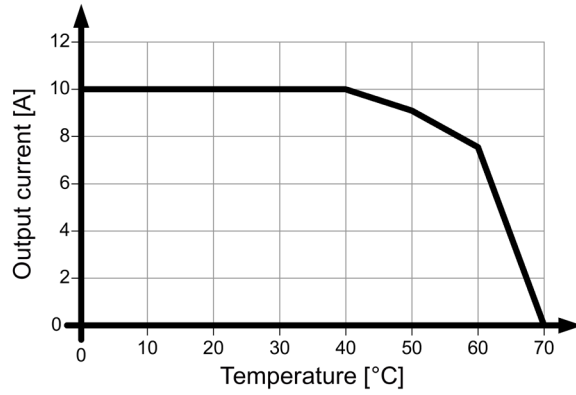

Figure 4-15 6EP1456-3BA00 mounting position (4)

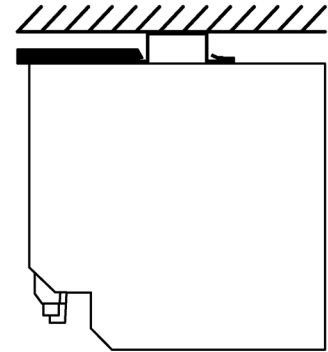
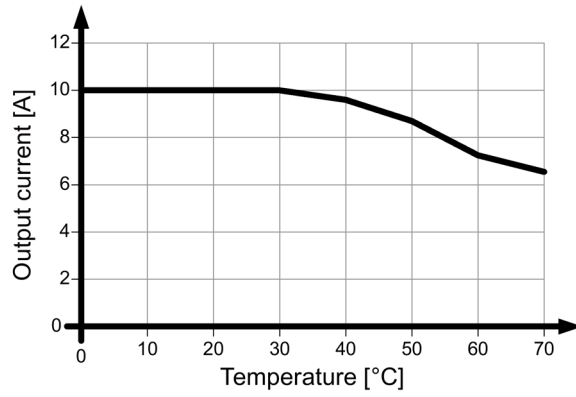

Figure 4-16 6EP1456-3BA00 mounting position (5)

4.2.3 6EP1424-3BA00

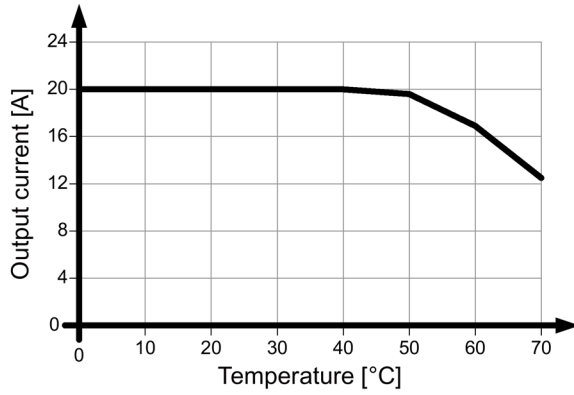

Figure 4-17 6EP1424-3BA00 mounting position (1)

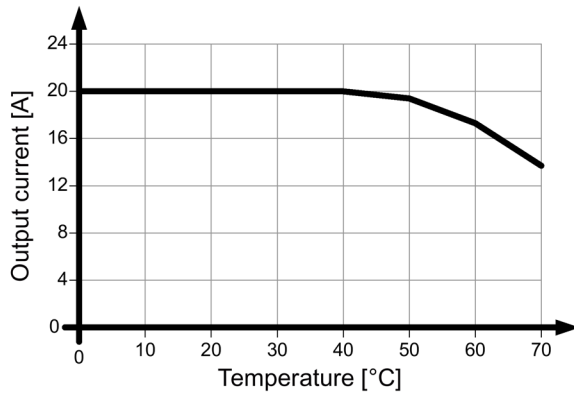
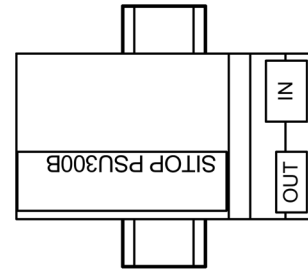

Figure 4-18 6EP1424-3BA00 mounting position (2)

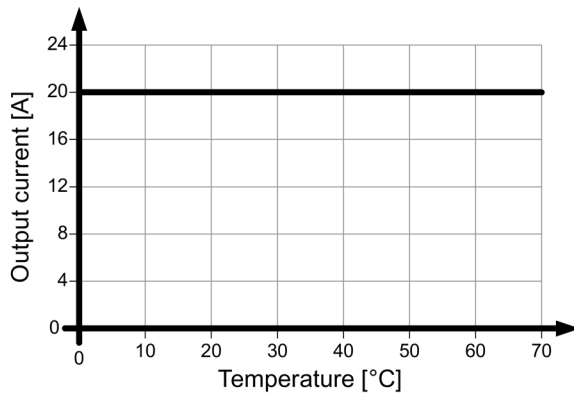
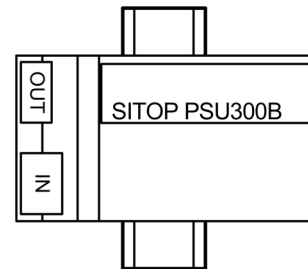
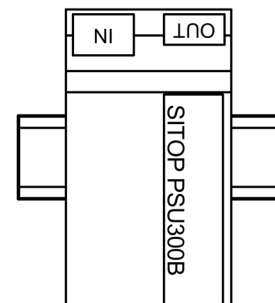

Figure 4-19 6EP1424-3BA00 mounting position (3)



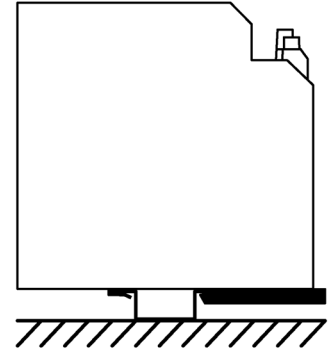
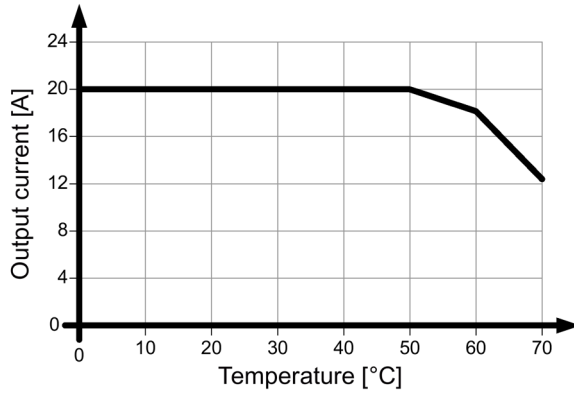

Figure 4-20 6EP1424-3BA00 mounting position (4)

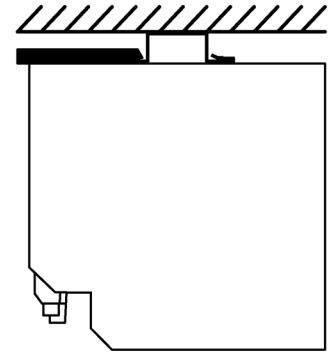
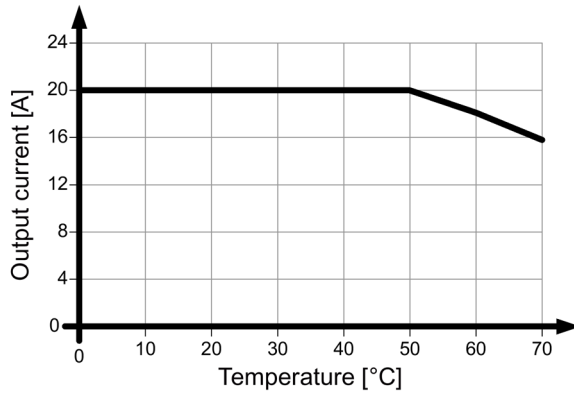

Figure 4-21 6EP1424-3BA00 mounting position (5)

4.2.4 6EP1436-3BA20

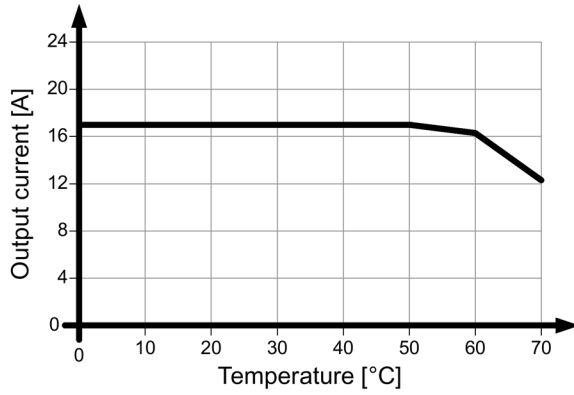

Figure 4-22 6EP1436-3BA20 mounting position (1)

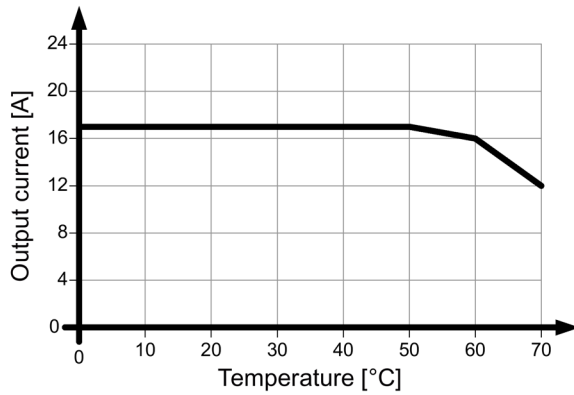
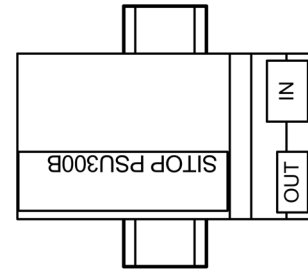

Figure 4-23 6EP1436-3BA20 mounting position (2)

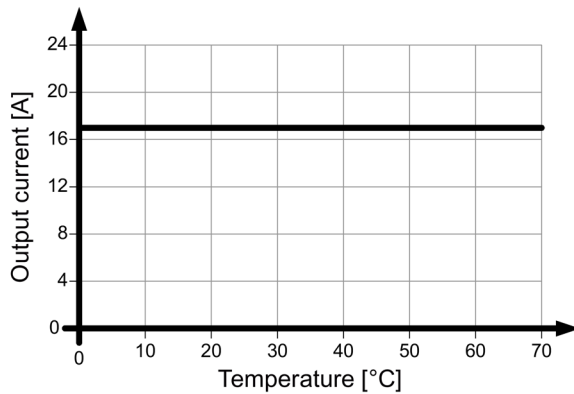
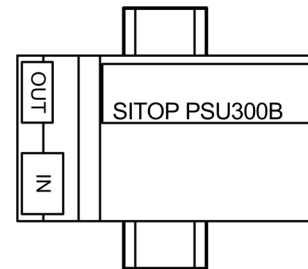
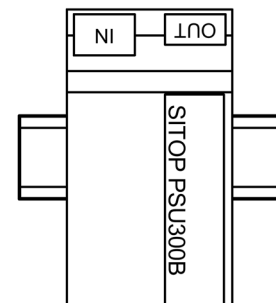

Figure 4-24 6EP1436-3BA20 mounting position (3)



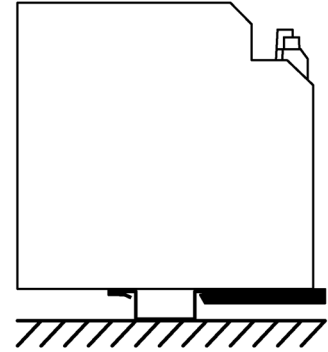
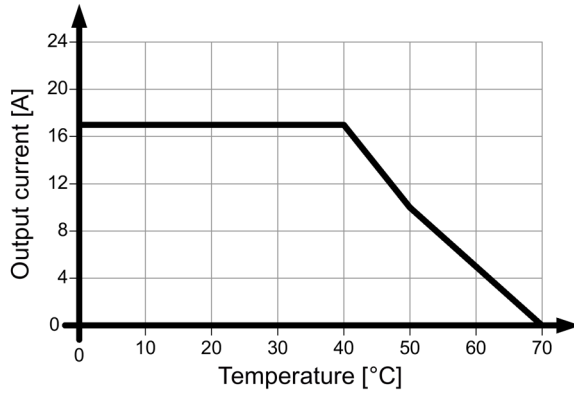

Figure 4-25 6EP1436-3BA20 mounting position (4)

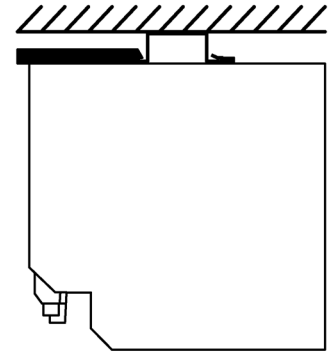
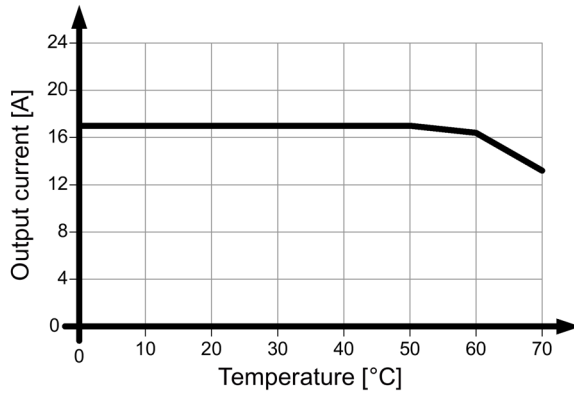

Figure 4-26 6EP1436-3BA20 mounting position (5)

4.2.5 6EP1437-3BA20

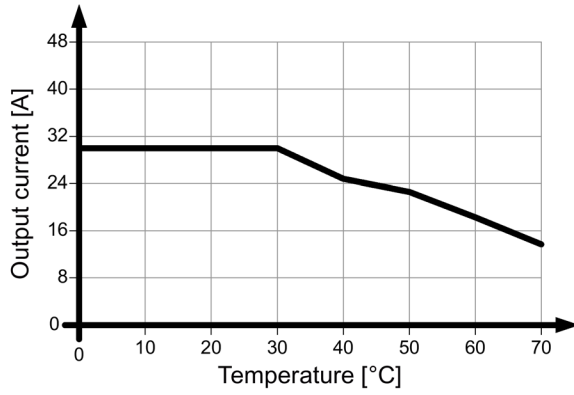

Figure 4-27 6EP1437-3BA20 mounting position (1)

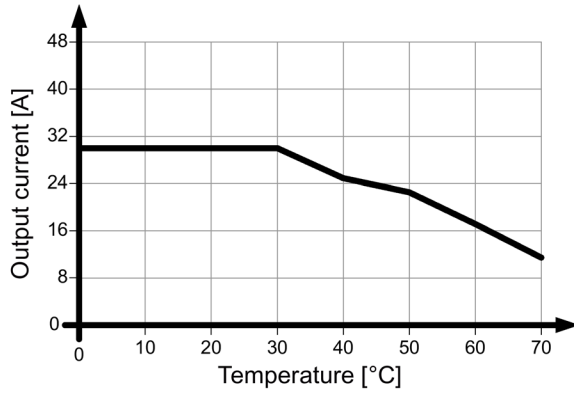
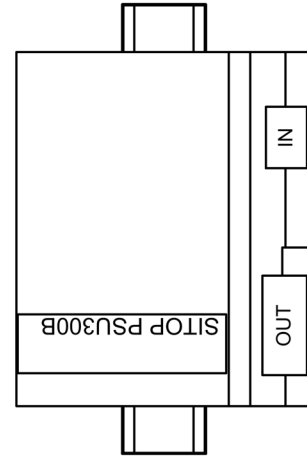
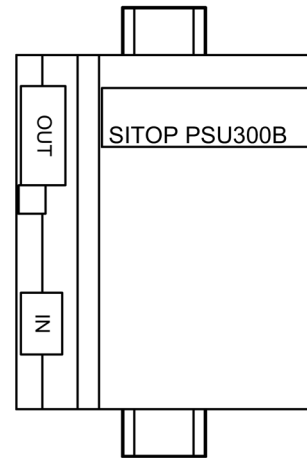

Figure 4-28 6EP1437-3BA20 mounting position (2)





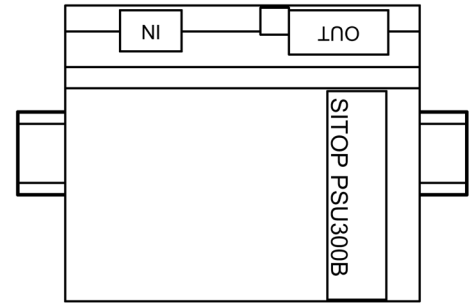
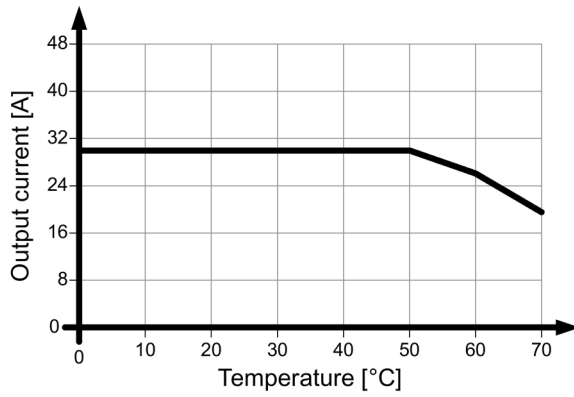

Figure 4-29 6EP1437-3BA20 mounting position (3)

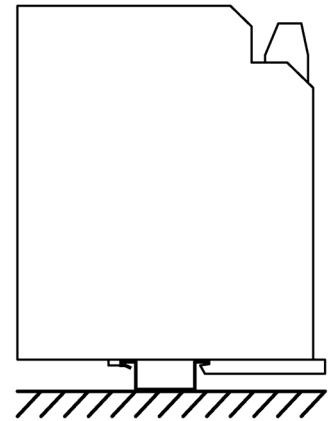
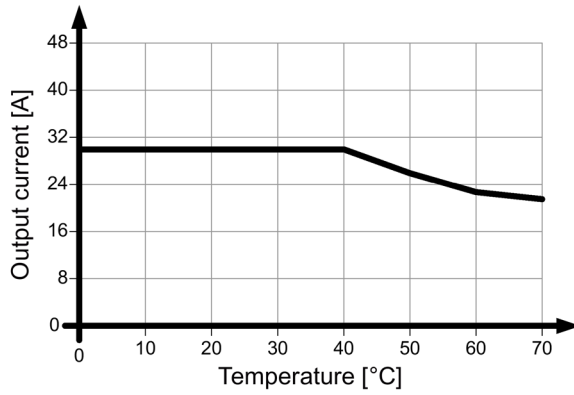

Figure 4-30 6EP1437-3BA20 mounting position (4)

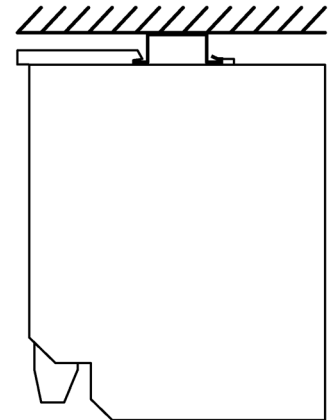
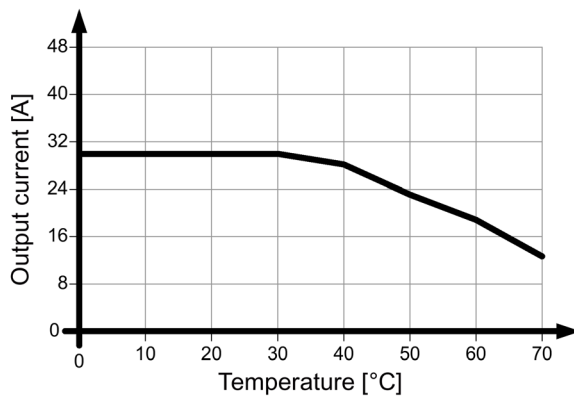

Figure 4-31 6EP1437-3BA20 mounting position (5)



<p><b>⚠ WARNING</b></p> <p><b>Hazard due to electric shock</b></p> <p>Before installation or maintenance work can begin, the system's main switch must be switched off and measures taken to prevent it being switched on again. If this instruction is not observed, touching live parts can result in death or serious injury.</p>
--

## 5.1 Line-side connection

The SITOP PSU300M/300B power supply is designed for connection to a 3-phase AC line supply (TN or TT system according to VDE 0100 T 300/IEC 364-3) with a rated voltage of 3-phase 400-500 V AC, 50/60 Hz, IT system with rated voltages 3-phase 400-480 V AC.

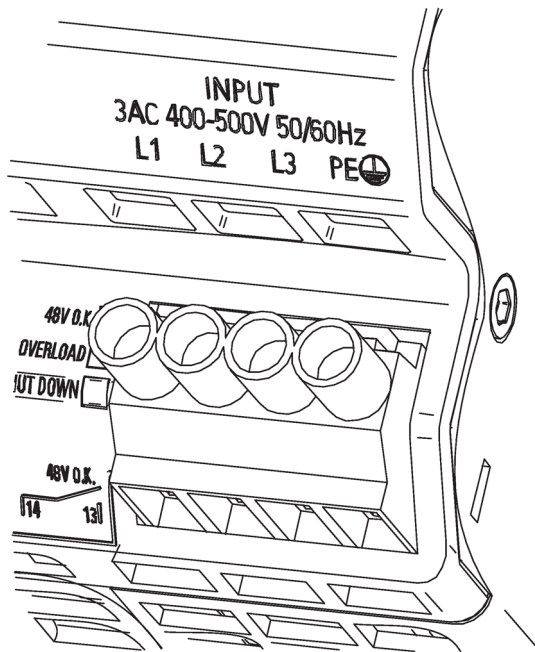

Figure 5-1 Line connection (example: 6EP1456-3BA00)

The line supply is connected using terminals L1, L2, L3 and PE (see Figure 5-1 Line connection (example: 6EP1456-3BA00) (Page 35)), and must be implemented according to IEC 60364 and EN 50178 . A protective device (miniature circuit breaker or circuit breaker) and a disconnection unit for the power supply must be provided. A ground-fault circuit interrupter is not permissible against indirect contact as the only protective measure. This applies for the complete line supply protected by the ground-fault circuit interrupter.

**Protection**

<b>SITOP PSU300M/300B</b>	<b>Recommended line-side protection</b>
6EP1436-3BA10 (24 V / 20 A)	3-pole coupled miniature circuit breaker (IEC 898), characteristic C, 6-16 A or 3RV2011-1EA10 circuit breaker, setting of the thermal overcurrent trip: 3 A or 3RV2711-1DD10 circuit breaker (branch circuit protection according to UL 489)
6EP1456-3BA00 (48 V / 10 A)	3-pole coupled miniature circuit breaker (IEC 898), characteristic C, 6-16 A or 3RV2011-1EA10 circuit breaker, setting of the thermal overcurrent trip: 3 A or 3RV2711-1DD10 circuit breaker (branch circuit protection according to UL 489)
6EP1424-3BA00 (12 V / 20 A)	3-pole coupled miniature circuit breaker (IEC 898), characteristic C, 6-10 A or 3RV2011-1EA10 circuit breaker, setting of the thermal overcurrent trip: 3 A or 3RV2711-1DD10 circuit breaker (branch circuit protection according to UL 489)
6EP1436-3BA20 (24 V / 17 A)	3-pole coupled miniature circuit breaker (IEC 898), characteristic C, 6-16 A or 3RV2011-1EA10 circuit breaker, setting of the thermal overcurrent trip: 3 A or 3RV2711-1DD10 circuit breaker (branch circuit protection according to UL 489)
6EP1437-3BA20 (24 V / 30 A)	3-pole coupled miniature circuit breaker (IEC 898), characteristic C, 10-16 A or 3RV2011-1EA10 circuit breaker, setting of the thermal overcurrent trip: 3 A or 3RV2711-1DD10 circuit breaker (branch circuit protection according to UL 489)

The protective conductor of the line supply must be connected at the PE terminal.

Other country-specific regulations may have to be observed when installing the device.

## 5.2 Output-side connection

At its output, the SITOP PSU300M/300B power supply provides an isolated (= non-grounded) SELV output voltage (Safety Extra Low Voltage). The output of the power supply is no-load, overload, and short-circuit proof. If an overload occurs, the electronic current limiting function limits the output current to a maximum value (see Section Technical data (Page 39)).

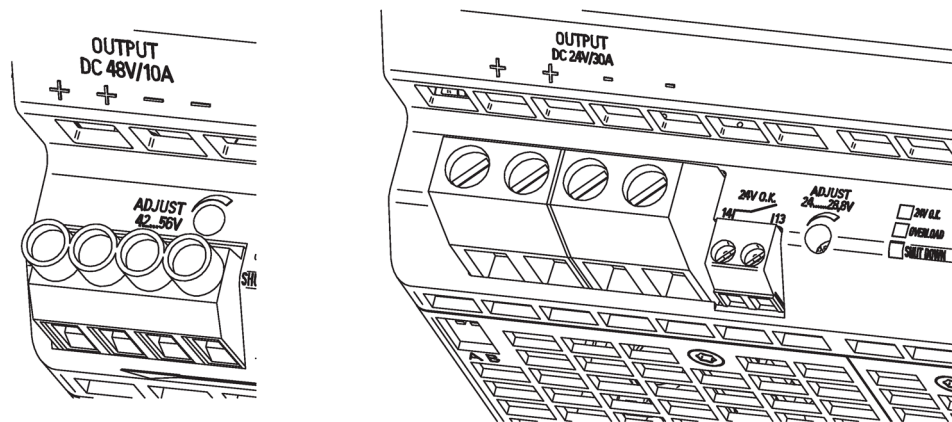

Figure 5-2 Output connection (example 6EP1456-3BA00 / 6EP1437-3BA20)

The output voltage is connected via the + and - terminals at the output of the power supply (see Figure 5-2 Output connection (example 6EP1456-3BA00 / 6EP1437-3BA20) (Page 37)). Ensure that the output cables are dimensioned correctly for the maximum output current rms value and fused accordingly.

### Note

If the safety concept of the plant or system specifies that the DC output circuit should be grounded (PELV), then it is permissible that the output voltage of the SITOP power supply is grounded. In this case, ideally, the grounding at the output should be directly connected from terminal "-" of the power supply to a suitable connection point of the protective conductor system (PE) of the plant or system.



## Technical data

---

### Note

Technical data is applicable for a rated input voltage, rated load and +25° C ambient temperature (if nothing else is specified).

---

### 6.1 Input

	6EP1436-3BA10 (24 V / 20 A)	6EP1456-3BA00 (48 V / 10 A)
Input	3-phase, AC	3-phase, AC
Rated voltage value U <sub>e</sub> rated	400-500 V	400-500 V
Voltage range	320 ... 575 V	320 ... 575 V
• Remark	Derating at U <sub>e</sub> < 340 V: 10% [I <sub>a</sub> ]	No derating
Wide-range input	Yes	Yes
Overvoltage strength	2.3 × U <sub>e</sub> rated, 1.3 ms	2.3 × U <sub>e</sub> rated, 1.3 ms
Power failure buffering at I <sub>a</sub> rated, min	15 ms	15 ms
• Remark: at U <sub>e</sub> = 400 V		
Rated line frequency	50-60 Hz	50-60 Hz
Line frequency range	47 ... 63 Hz	47 ... 63 Hz
Input current / at rated value of input voltage 400 V	1.2 A	1.2 A
Input current / at rated value of input voltage 500 V	1 A	1 A
Inrush current limiting (+25° C), max.	18 A	18 A
I <sup>2</sup> t, max	0.8 A <sup>2</sup> s	0.8 A <sup>2</sup> s
Integrated input fuse	None	None
Protection in the line feeder cable (IEC 898)	Required: 3-pole, coupled miniature circuit breaker 6 ... 16 A characteristic C or circuit breaker 3RV2011-1DA10 (setting 3 A) or 3RV2711-1DD10 (UL 489)	

Technical data

6.1 Input

	6EP1424-3BA00 (12 V / 20 A)	6EP1436-3BA20 (24 V / 17 A)	6EP1437-3BA20 (24 V / 30 A)
Input	3-phase, AC	3-phase, AC	3-phase, AC
Rated voltage value Ue rated	400-500 V	400-500 V	400-500 V
Voltage range	320 ... 575 V	320 ... 575 V	320 ... 575 V
Wide-range input	Yes	Yes	Yes
Overvoltage strength	2.3 × Ue rated, 1.3 ms	2.3 × Ue rated, 1.3 ms	2.3 × Ue rated, 1.3 ms
Power failure buffering at Ia rated, min	20 ms	20 ms	20 ms
• Remark: at Ue = 400 V			
Rated line frequency	50-60 Hz	50-60 Hz	50-60 Hz
Line frequency range	47 ... 63 Hz	47 ... 63 Hz	47 ... 63 Hz
Input current / at rated value of input voltage 400 V	0.7 A	1.2 A	1.6 A
Input current / at rated value of input voltage 500 V	0.6 A	1 A	1.3 A
Inrush current limiting (+25° C), max.	18 A	18 A	56 A
I <sup>2</sup> t, max	0.8 A <sup>2</sup> s	0.8 A <sup>2</sup> s	2.24 A <sup>2</sup> s
Integrated input fuse	None	None	None
Protection in the line feeder cable (IEC 898)	Required: 3-pole, coupled miniature circuit breaker 6 ... 10 A characteristic C or circuit breaker 3RV2011-1DA10 (setting 3 A) or 3RV2711-1DD10 (UL 489)		Required: 3-pole, coupled miniature circuit breaker 10 ... 16 A characteristic C or circuit breaker 3RV2011-1DA10 (setting 3 A) or 3RV2711-1DD10 (UL 489)

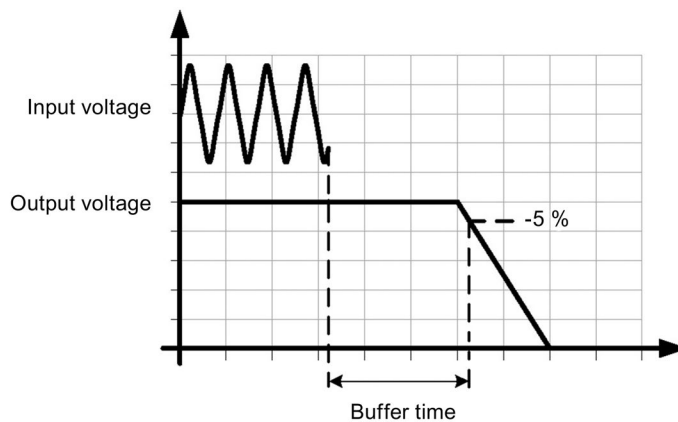

Figure 6-1 Power failure buffering



## 6.2 Output

	6EP1436-3BA10 (24 V/20 A)	6EP1456-3BA00 (48 V/10 A)
Output	Regulated, isolated DC voltage	Regulated, isolated DC voltage
Rated voltage value U <sub>a</sub> rated DC	24 V	48 V
Total tolerance, static ±	3 %	3 %
Static line regulation, approx.	0,1 %	0,1 %
Static load regulation, approx.	0,2 %	0,2 %
Residual ripple in the load range peak-peak, max.	100 mV	100 mV
Spikes peak-peak, max. (bandwidth, approx. 20 MHz)	200 mV	200 mV
Adjustment range	24 ... 28.8 V	42 ... 56 V
• Remark	Derating, see Section Potentiometer (Page 11)	Derating, see Section Potentiometer (Page 11)
Product function / output voltage can be adjusted	Yes	Yes
Output voltage setting	Via potentiometer	Via potentiometer
• Remark	Max. 480 W	Max. 480 W
Operating display	LED green for "24 V O.K."	LED green for "48 V O.K."
Signaling	Relay contact (NO contact, rating 60 V DC / 0.3 A) for "24 V O.K."	Relay contact (NO contact, rating 60 V DC / 0.3 A) for "48 V O.K."
Response when switching on/off	No overshoot of U <sub>a</sub> (Soft-Start)	No overshoot of U <sub>a</sub> (Soft-Start)
Starting delay, max.	2.5 s	2.5 s
Voltage rise, typ.	150 ms	150 ms
Voltage rise time of the output voltage, maximum	500 ms	500 ms
Rated current value I <sub>a</sub> rated	20 A	10 A
Current range	0 ... 20 A	0 ... 10 A
• Remark	14 A to +70° C	7 A to +70° C
Output active power / typical	480 W	480 W
Constant overload current / for a short circuit when powering up / typical	23 A	11 A
Short-time overload current / for a short circuit during operation, typical	60 A	23 A
Duration of the current overload capability / for a short circuit during operation	25 ms	25 ms
Can be connected in parallel to increase the power rating	Yes	Yes
• Remark	Switchable characteristic curve (see Figure 2-6 Selector switch (example 6EP1456-3BA00 / 6EP1437-3BA20) (Page 15))	Switchable characteristic curve (see Figure 2-6 Selector switch (example 6EP1456-3BA00 / 6EP1437-3BA20) (Page 15))

Technical data

6.2 Output

	6EP1436-3BA10 (24 V/20 A)	6EP1456-3BA00 (48 V/10 A)
Number of units connected in parallel to increase the power rating, units	2	2
Output characteristic	See Figure 6-3 6EP1436-3BA10 single operation output characteristic curve (Page 44)	See Figure 6-4 6EP1456-3BA00 single operation output characteristic curve (Page 44)

	6EP1424-3BA00 (12 V / 20 A)	6EP1436-3BA20 (24 V / 17 A)	6EP1437-3BA20 (24 V / 30 A)
Output	Regulated, isolated DC voltage	Regulated, isolated DC voltage	Regulated, isolated DC voltage
Rated voltage value U <sub>a</sub> rated DC	12 V	24 V	24 V
Total tolerance, static ±	3 %	3 %	3 %
Static line regulation, approx.	2 %	0,1 %	0,1 %
Static load regulation, approx.	4 %	0,2 %	0,1 %
Residual ripple in the load range peak-peak, max.	100 mV	100 mV	100 mV
Spikes peak-peak, max. (bandwidth, approx. 20 MHz)	200 mV	200 mV	200 mV
Adjustment range	12 ... 14 V	24 ... 28.8 V	24 ... 28.8 V
Product function / output voltage can be adjusted	Yes	Yes	Yes
Output voltage setting	Via potentiometer	Via potentiometer	Via potentiometer
• Remark	-	Max. 480 W	-
Operating display	LED green for "12 V O.K."	LED green for "24 V O.K."	LED green for "24 V O.K."
Signaling	Relay contact (NO contact, rating 60 V DC / 0.3 A) for "12 V O.K."	Relay contact (NO contact, rating 60 V DC / 0.3 A) for "24 V O.K."	
Response when switching on/off	No overshoot of U <sub>a</sub> (Soft-Start)	No overshoot of U <sub>a</sub> (Soft-Start)	No overshoot of U <sub>a</sub> (Soft-Start)
Starting delay, max.	2.5 s	2.5 s	2.5 s
Voltage rise, typ.	20 ms	40 ms	20 ms
Voltage rise time of the output voltage, maximum	500 ms	500 ms	500 ms
Rated current value I <sub>a</sub> rated	20 A	20 A	30 A
Current range	0 ... 20 A	0 ... 17 A	0 ... 30 A
• Remark	20 A to +70° C	14 A to +70° C	25 A to +70° C
Output active power / typical	240 W	408 W	720 W
Constant overload current for a short-circuit when powering up, typical	22 A	19 A	32 A

	6EP1424-3BA00 (12 V / 20 A)	6EP1436-3BA20 (24 V / 17 A)	6EP1437-3BA20 (24 V / 30 A)
Short-time overload current for a short-circuit during operation, typical	60 A	-	-
Duration of the current overload capability for a short-circuit during operation	25 ms	-	-
Can be connected in parallel to increase the power rating	Yes	Yes	Yes
<ul style="list-style-type: none"> <li>Remark</li> </ul>	Switchable characteristic curve (see Figure 2-6 Selector switch (example 6EP1456-3BA00 / 6EP1437-3BA20) (Page 15))	Switchable characteristic curve (see Figure 2-6 Selector switch (example 6EP1456-3BA00 / 6EP1437-3BA20) (Page 15))	Switchable characteristic curve (see Figure 2-6 Selector switch (example 6EP1456-3BA00 / 6EP1437-3BA20) (Page 15))
Number of devices that can be connected in parallel to increase the power rating, units	2	2	2
Output characteristic	See Figure 6-5 6EP1424-3BA00 single operation output characteristic curve (Page 44)	See Figure 6-6 6EP1436-3BA20 single operation output characteristic curve (Page 45)	See Figure 6-7 6EP1437-3BA20 single operation output characteristic curve (Page 45)

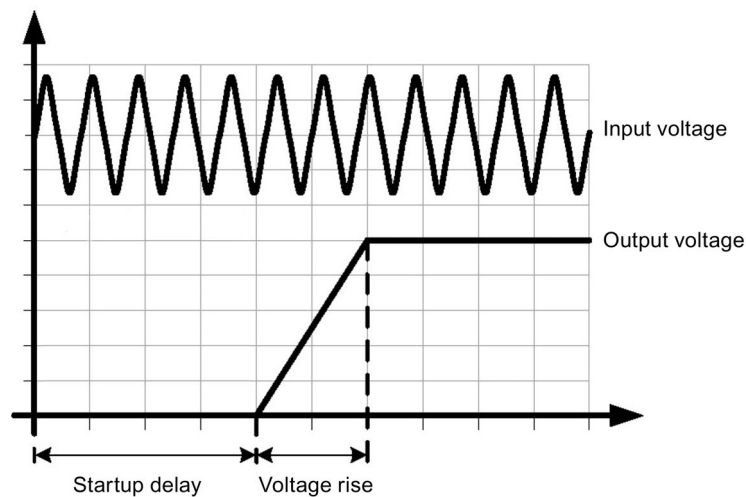

Figure 6-2 Starting delay/voltage rise

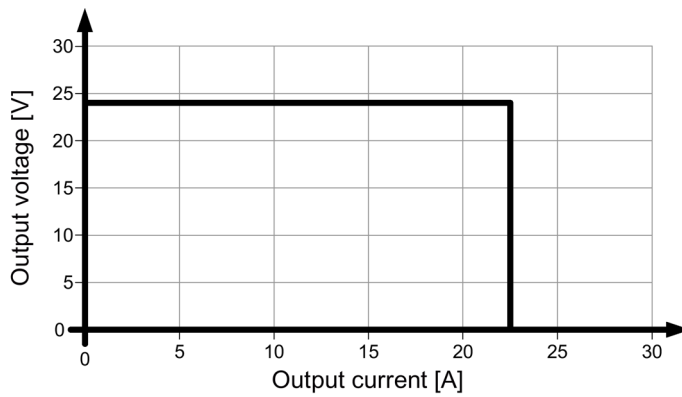

Figure 6-3 6EP1436-3BA10 single operation output characteristic curve

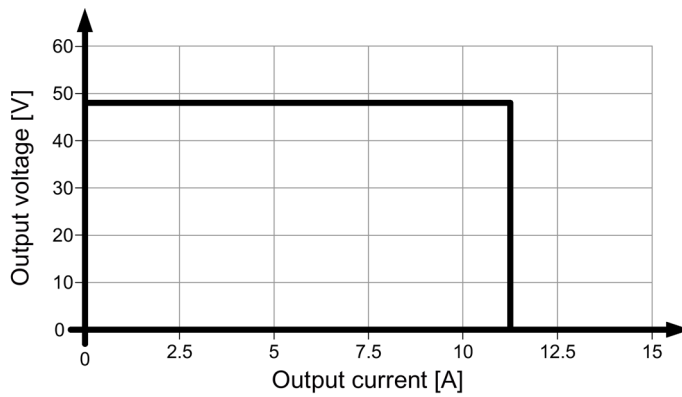

Figure 6-4 6EP1456-3BA00 single operation output characteristic curve

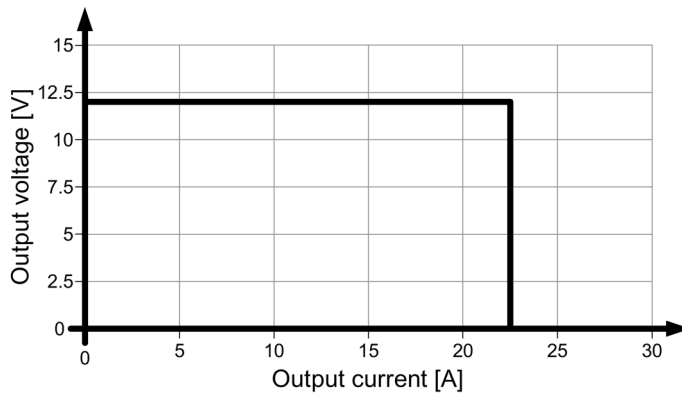

Figure 6-5 6EP1424-3BA00 single operation output characteristic curve

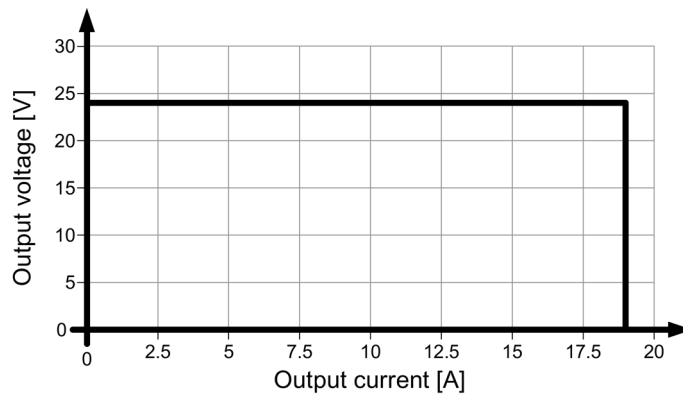

Figure 6-6 6EP1436-3BA20 single operation output characteristic curve

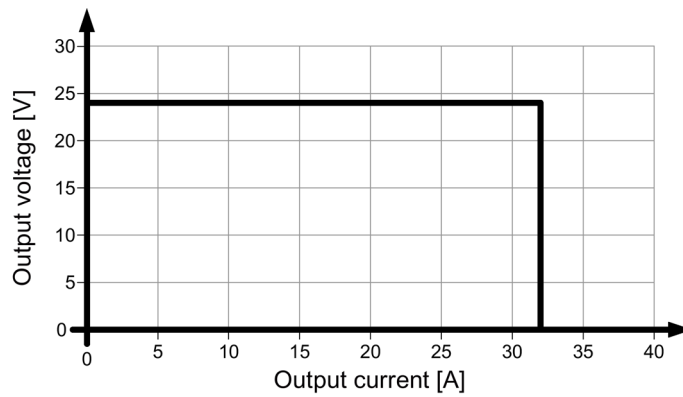

Figure 6-7 6EP1437-3BA20 single operation output characteristic curve

The device supplies a constant output voltage until the current limit is reached. If overload occurs, the output current is limited and the output voltage lowered.

**Selector switch A closed (parallel operation):**

The output voltage decreases with increasing output current.

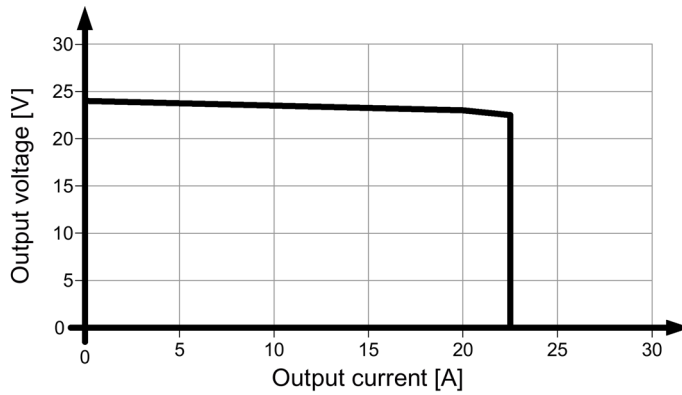

Figure 6-8 6EP1436-3BA10 parallel operation output characteristic curve

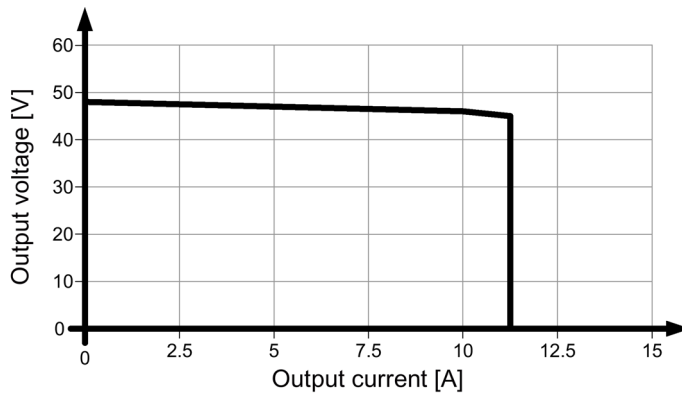

Figure 6-9 6EP1456-3BA00 parallel operation output characteristic curve

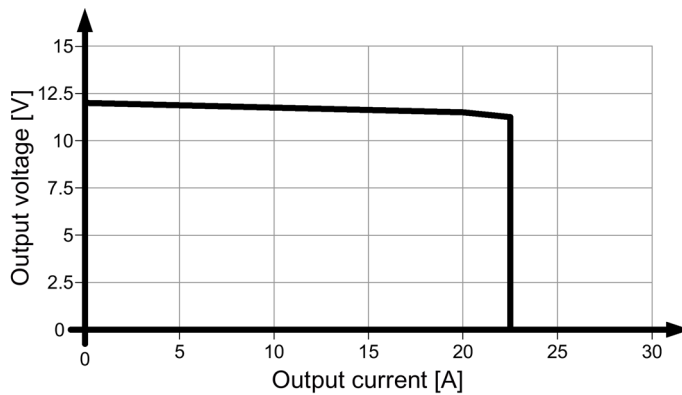

Figure 6-10 6EP1424-3BA00 parallel operation output characteristic curve

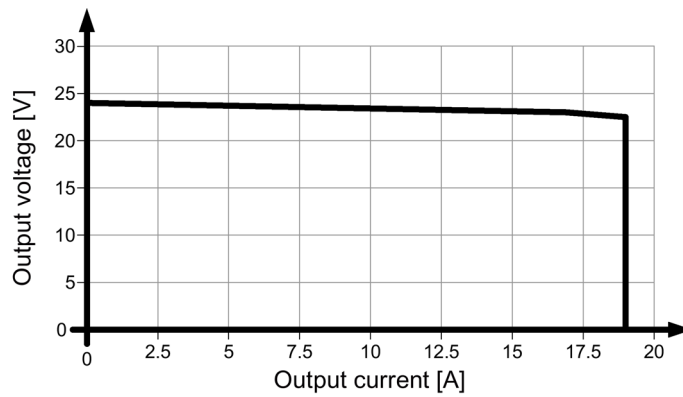

Figure 6-11 6EP1436-3BA20 parallel operation output characteristic curve

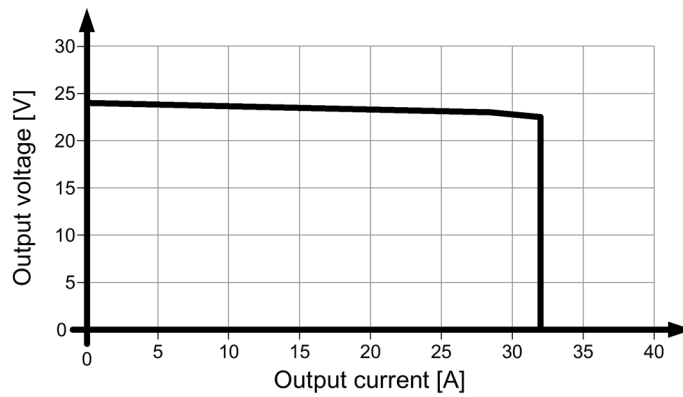

Figure 6-12 6EP1437-3BA20 parallel operation output characteristic curve

**Selector switch B closed (latching shutdown):**

The device will be shut down if the overload continues for longer than 100 ms.  
A reset is performed by switching the power supply OFF for at least 5 seconds.

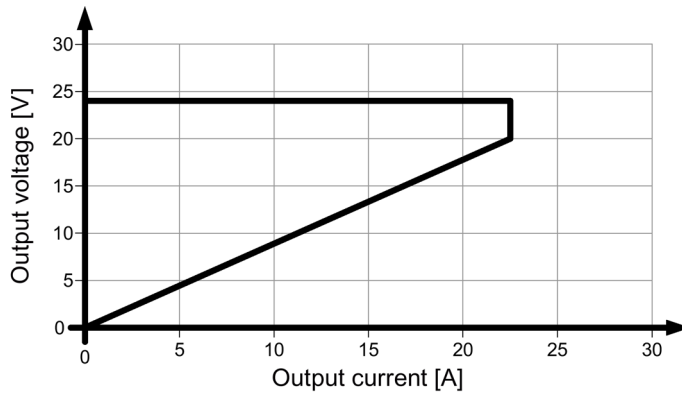

Figure 6-13 6EP1436-3BA10 latching shutdown output characteristic curve

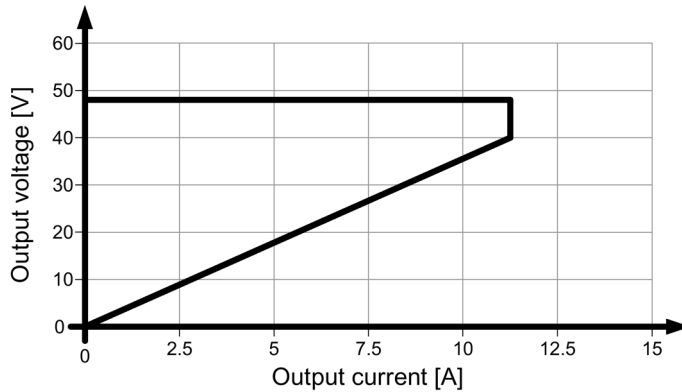

Figure 6-14 6EP1456-3BA00 latching shutdown output characteristic curve

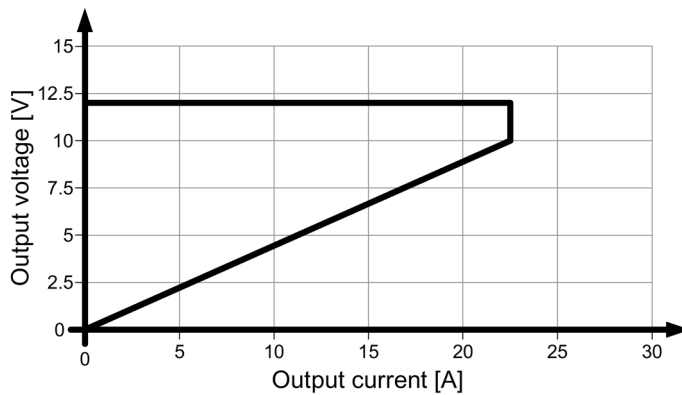

Figure 6-15 6EP1424-3BA00 latching shutdown output characteristic curve



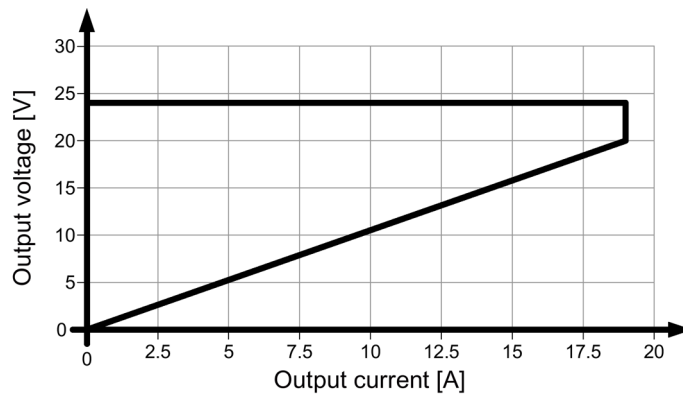

Figure 6-16 6EP1436-3BA20 latching shutdown output characteristic curve

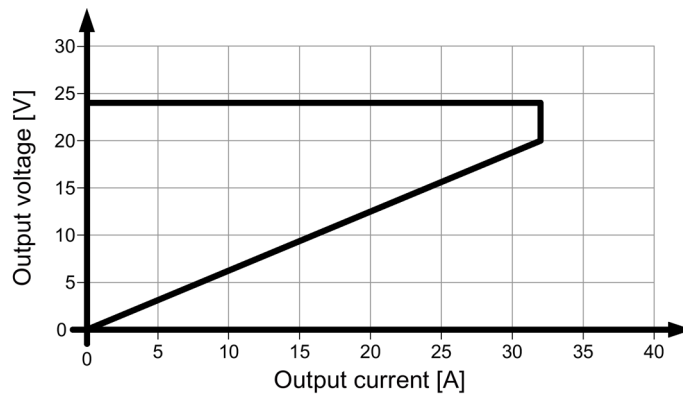

Figure 6-17 6EP1437-3BA20 latching shutdown output characteristic curve

### 6.3 Efficiency

	6EP1436-3BA10 (24 V/20 A)	6EP1456-3BA00 (48 V/10 A)
Efficiency at U <sub>a</sub> rated, I <sub>a</sub> rated, approx.	93 %	93 %
Power loss at U <sub>a</sub> rated, I <sub>a</sub> rated, approx.	36 W	36 W

	6EP1424-3BA00 (12 V / 20 A)	6EP1436-3BA20 (24 V / 17 A)	6EP1437-3BA20 (24 V / 30 A)
Efficiency at U <sub>a</sub> rated, I <sub>a</sub> rated, approx.	88 %	93 %	93 %
Power loss at U <sub>a</sub> rated, I <sub>a</sub> rated, approx.	20 W	31 W	50 W

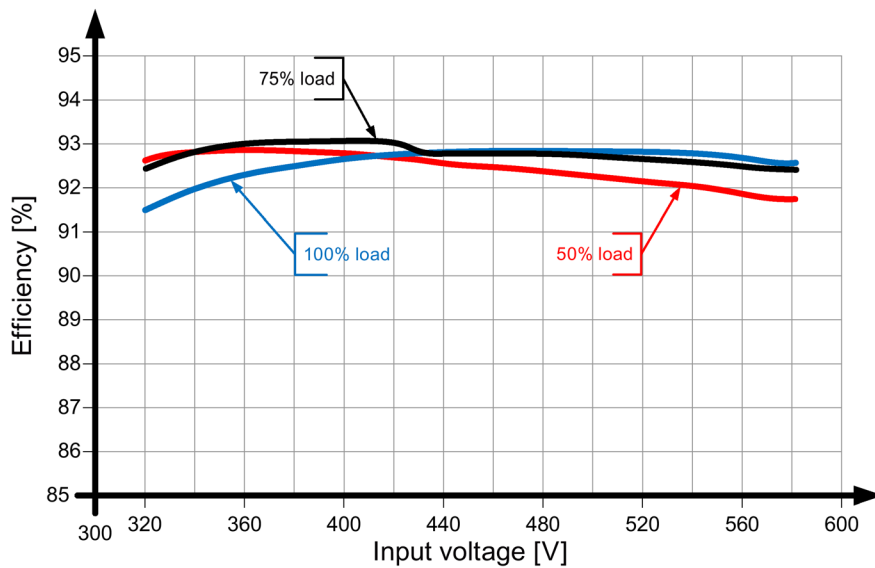

Figure 6-18 6EP1436-3BA10 efficiency

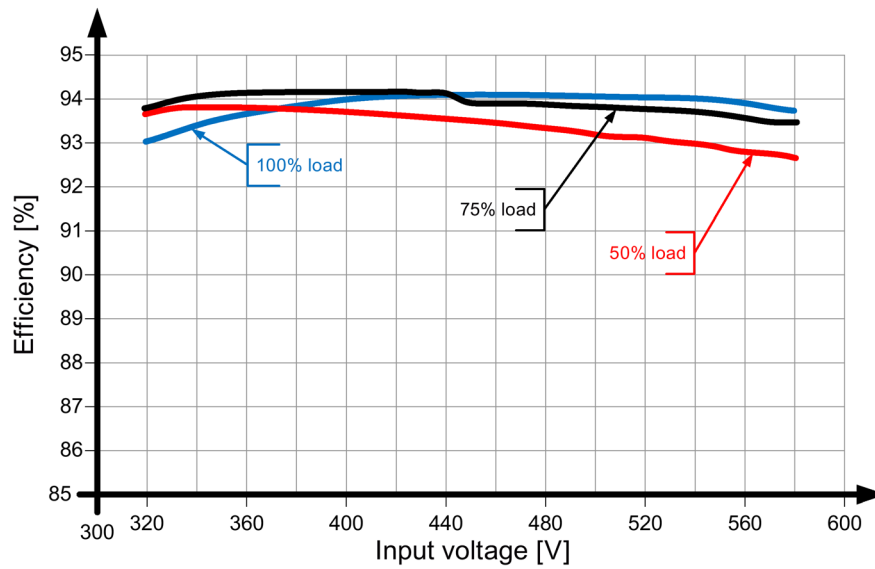

Figure 6-19 6EP1456-3BA00 efficiency

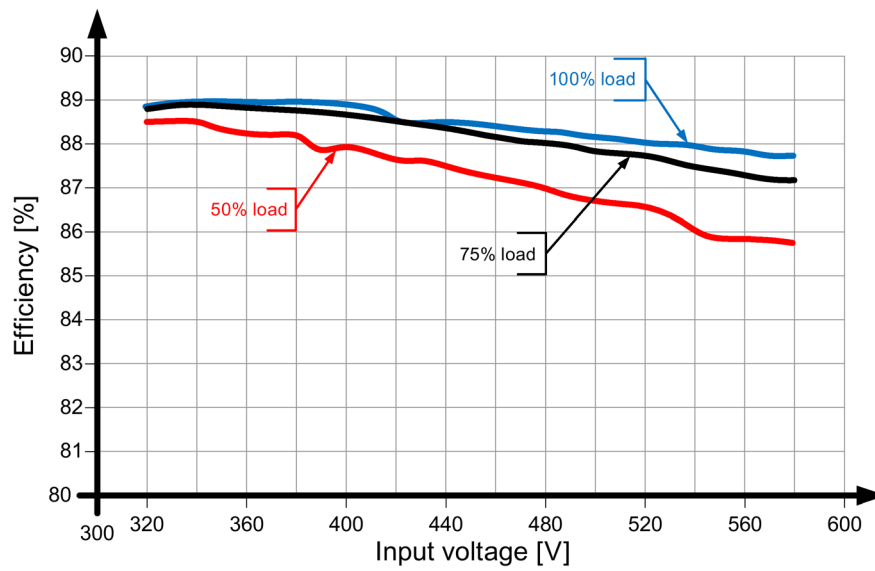

Figure 6-20 6EP1424-3BA00 efficiency

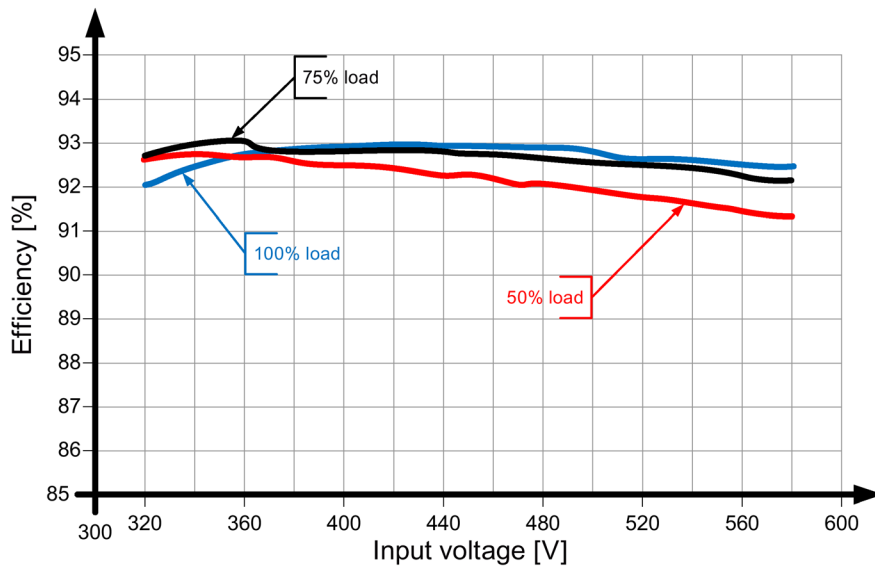

Figure 6-21 6EP1436-3BA20 efficiency

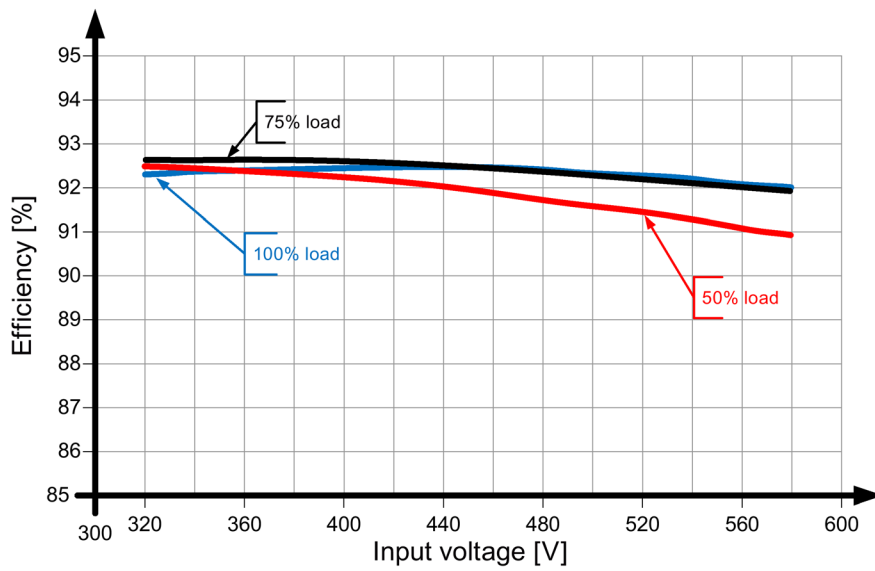

Figure 6-22 6EP1437-3BA20 efficiency

## 6.4 Closed-loop control

	6EP1436-3BA10 (24 V/20 A)	6EP1456-1BA00 (48 V/10 A)
Dyn. line regulation (U <sub>e</sub> rated ±15 %), max.	1 %	1 %
Dyn. load regulation (I <sub>a</sub> : 50/100/50%), U <sub>a</sub> ± typ.	2 %	2 %
Load step regulation time 50 to 100 %, typ.	2 ms	2 ms
Load step regulation time 100 to 50 %, typ.	2 ms	2 ms
Regulation time / maximum	10 ms	10 ms

	6EP1424-3BA00 (12 V / 20 A)	6EP1436-3BA20 (24 V / 17 A)	6EP1437-3BA20 (24 V / 30 A)
Dyn. line regulation (U <sub>e</sub> rated ±15 %), max.	2 %	1 %	1 %
Dyn. load regulation (I <sub>a</sub> : 50/100/50%), U <sub>a</sub> ± typ.	4 %	2 %	3 %
Load step regulation time 50 to 100 %, typ.	2 ms	2 ms	-
Load step regulation time 100 to 50 %, typ.	2 ms	2 ms	-
Regulation time / maximum	10 ms	10 ms	10 ms

## 6.5 Protection and monitoring

	<b>6EP1436-3BA10 (24 V/20 A)</b>	<b>6EP1456-3BA00 (48 V/10 A)</b>
Output overvoltage protection	< 35 V	Yes, according to EN 60950
Current limitation, typ.	23 A	11 A
Property of the output / short-circuit proof	Yes	Yes
Short-circuit protection	Optional constant current characteristic approx. 23 A or "latching shutdown"	Optional constant current characteristic approx. 11 A or "latching shutdown"
Continuous short-circuit current / rms value / typical	23 A	11 A
• Remark	Overload capability 150% I <sub>a</sub> rated up to 5 s/min	Overload capability 150% I <sub>a</sub> rated up to 5 s/min
Overload/short-circuit indicator	Yellow LED for "overload", red LED for "latching shutdown"	Yellow LED for "overload", red LED for "latching shutdown"

	<b>6EP1424-3BA00 (12 V / 20 A)</b>	<b>6EP1436-3BA20 (24 V / 17 A)</b>	<b>6EP1437-3BA20 (24 V / 30 A)</b>
Output overvoltage protection	< 35 V	< 35 V	< 35 V
Current limitation, typ.	22 A	19 A	32 A
Property of the output / short-circuit proof	Yes	Yes	Yes
Short-circuit protection	Optional constant current characteristic approx. 22 A or "latching shutdown"	Optional constant current characteristic approx. 19 A or "latching shutdown"	Optional constant current characteristic approx. 32 A or "latching shutdown"
Continuous short-circuit current / rms value / typical	22 A	19 A	32 A
• Remark	Overload capability 150% I <sub>a</sub> rated up to 5 s/min	-	-
Overload / short-circuit display	Yellow LED for "overload", red LED for "latching shutdown"	Yellow LED for "overload", red LED for "latching shutdown"	Yellow LED for "overload", red LED for "latching shutdown"

## 6.6 MTBF

	<b>6EP1436-3BA10 (24 V/20 A)</b> <b>6EP1456-3BA00 (48 V/10 A)</b> <b>6EP1424-3BA00 (12 V/20 A)</b> <b>6EP1436-3BA20 (24 V/17 A)</b> <b>6EP1437-3BA20 (24 V / 30 A)</b>
Mean Time Between Failures	SN29500: > 500,000 hours (typ. 700,000 hours) at 40 °C, rated load, 24-hour operation

## 6.7 Mechanical system

	<b>6EP1436-3BA10 (24 V/20 A)</b>	<b>6EP1456-3BA00 (48 V/10 A)</b>
Connection system	Screw-type terminal	Screw-type terminal
Connections / line supply	L1, L2, L3, PE: 1 screw terminal each for 0.2 ... 6 (4) mm <sup>2</sup> solid (finely stranded)	L1, L2, L3, PE: 1 screw terminal each for 0.2 ... 6 (4) mm <sup>2</sup> solid (finely stranded)
Connections / output	+, -: 2 screw terminals each for 0.2 ... 6 (4) mm <sup>2</sup> solid (finely stranded)	+, -: 2 screw terminals each for 0.2 ... 6 (4) mm <sup>2</sup> solid (finely stranded)
Connections / auxiliary contacts	13, 14 (signaling contact): 1 screw terminal each for 0.14 ... 1.5 mm <sup>2</sup> solid (finely stranded)	13, 14 (signaling contact): 1 screw terminal each for 0.14 ... 1.5 mm <sup>2</sup> solid (finely stranded)
Width of the housing	70 mm	70 mm
Height of the housing	125 mm	125 mm
Depth of the housing	125 mm	125 mm
Mounting width	70 mm	70 mm
Mounting height	225 mm	225 mm
Weight, approx.	1.2 kg	1.2 kg
Product feature of the housing / housing that can be lined up next to one another	Yes	Yes
Type of mounting / panel mounting	No	No
Type of mounting / rail mounting	Yes	Yes
Type of mounting / S7-300 rail mounting	No	No
Mounting	Can be snapped onto standard EN 60715 35x7,5/15 mounting rails	Can be snapped onto standard EN 60715 35x7,5/15 mounting rails

6.7 Mechanical system

	<b>6EP1424-3BA00 (12 V / 20 A)</b>	<b>6EP1436-3BA20 (24 V / 17 A)</b>	<b>6EP1437-3BA20 (24 V / 30 A)</b>
Connection system	Screw-type terminal	Screw-type terminal	Screw-type terminal
Connections / line supply	L1, L2, L3, PE: 1 screw terminal each for 0.2 ... 6 (4) mm <sup>2</sup> solid (finely stranded)	L1, L2, L3, PE: 1 screw terminal each for 0.2 ... 6 (4) mm <sup>2</sup> solid (finely stranded)	L1, L2, L3, PE: 1 screw terminal each for 0.2 ... 6 (4) mm <sup>2</sup> solid (finely stranded)
Connections / output	+, -: 2 screw terminals each for 0.2 ... 6 (4) mm <sup>2</sup> solid (finely stranded)	+, -: 2 screw terminals each for 0.2 ... 6 (4) mm <sup>2</sup> solid (finely stranded)	+, -: 2 screw terminals each for 0.5 ... 16 (10) mm <sup>2</sup> solid (finely stranded)
Connections/auxiliary contacts 13, 14 (signaling contact)	1 screw terminal each for 0.14 ... 1.5 mm <sup>2</sup> solid (finely stranded)	1 screw terminal each for 0.14 ... 1.5 mm <sup>2</sup> solid (finely stranded)	1 screw terminal each for 0.14 ... 4 (2.5) mm <sup>2</sup> solid (finely stranded)
Width of the housing	70 mm	70 mm	150 mm
Height of the housing	125 mm	125 mm	125 mm
Depth of the housing	125 mm	125 mm	150 mm
Mounting width	70 mm	70 mm	150 mm
Mounting height	225 mm	225 mm	225 mm
Weight, approx.	1.2 kg	1.2 kg	3.4 kg
Product feature of the housing / housing that can be lined up next to one another	Yes	Yes	Yes
Type of mounting / panel mounting	No	No	No
Type of mounting / rail mounting	Yes	Yes	Yes
Type of mounting / S7-300 rail mounting	No	No	No
Mounting	Can be snapped onto standard EN 60715 35x7,5/15 mounting rails		Can be snapped onto standard EN 60715 35x15 mounting rails



## 6.8 Accessories

	6EP1436-3BA10 (24 V/20 A)	6EP1456-3BA00 (48 V/10 A)
Electrical accessories	Buffer module, redundancy module	-
Mechanical accessories	Device identification labels 20 mm × 7 mm, pastel turquoise 3RT1900-1SB20	

	6EP1424-3BA00 (12 V / 20 A)	6EP1436-3BA20 (24 V / 17 A)	6EP1437-3BA20 (24 V / 30 A)
Electrical accessories	-	Buffer module, redundancy module	Buffer module, redundancy module
Mechanical accessories	Device identification labels 20 mm × 7 mm, pastel turquoise 3RT1900-1SB20		

## 6.9 Dimension drawing

See Section Dimensions and weight (Page 17)

CAD data that can be downloaded from the Internet:

6EP1436-3BA10  
([http://www.automation.siemens.com/bilddb/index.aspx?objKey=G\\_KT01\\_XX\\_00459](http://www.automation.siemens.com/bilddb/index.aspx?objKey=G_KT01_XX_00459))

6EP1456-3BA00  
([http://www.automation.siemens.com/bilddb/index.aspx?objKey=G\\_KT01\\_XX\\_00568](http://www.automation.siemens.com/bilddb/index.aspx?objKey=G_KT01_XX_00568))

6EP1424-3BA00  
([http://www.automation.siemens.com/bilddb/index.aspx?objKey=G\\_KT01\\_XX\\_00680](http://www.automation.siemens.com/bilddb/index.aspx?objKey=G_KT01_XX_00680))

6EP1436-3BA20  
([http://www.automation.siemens.com/bilddb/index.aspx?objKey=G\\_KT01\\_XX\\_00724](http://www.automation.siemens.com/bilddb/index.aspx?objKey=G_KT01_XX_00724))

6EP1437-3BA20  
([http://www.automation.siemens.com/bilddb/index.aspx?objKey=G\\_KT01\\_XX\\_00683](http://www.automation.siemens.com/bilddb/index.aspx?objKey=G_KT01_XX_00683))



## Safety, approvals, EMC

### 7.1 Safety

	6EP1436-3BA10 (24 V/20 A)	6EP1456-3BA00 (48 V/10 A)
Primary/secondary galvanic isolation	Yes	Yes
Electrical isolation	SELV output voltage Ua according to EN 60950-1 and EN 50178	SELV output voltage Ua according to EN 60950-1 and EN 50178
Protection class	Class I	Class I
Degree of protection (EN 60529)	IP 20	IP 20
Leakage current, typ.	0.9 mA	0.9 mA
Leakage current, max.	3.5 mA	3.5 mA
Test voltage	See Table 7-1 Test voltage (Page 60)	See Table 7-1 Test voltage (Page 60)

	6EP1424-3BA00 (12 V / 20 A)	6EP1436-3BA20 (24 V / 17 A)	6EP1437-3BA20 (24 V / 30 A)
Primary/secondary galvanic isolation	Yes	Yes	Yes
Electrical isolation	SELV output voltage Ua according to EN 60950-1 and EN 50178	SELV output voltage Ua according to EN 60950-1 and EN 50178	SELV output voltage Ua according to EN 60950-1 and EN 50178
Protection class	Class I	Class I	Class I
Degree of protection (EN 60529)	IP20	IP20	IP20
Leakage current, typ.	0.9 mA	0.9 mA	0.4 mA
Leakage current, max.	3.5 mA	3.5 mA	3.5 mA
Test voltage	See Table 7-1 Test voltage (Page 60)	See Table 7-1 Test voltage (Page 60)	See Table 7-1 Test voltage (Page 60)

## 7.2 Test voltage

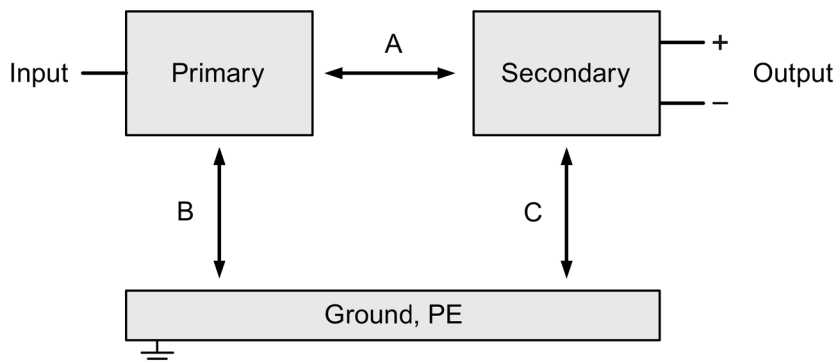

Figure 7-1 Test voltage without auxiliary contact diagram

Only the manufacturer can perform the type test and production test; users can also perform the field test.

Preconditions for performing the field test:

Tests (A) & (B)

- Connect the input terminals with one another
- Connect the output terminals and PE together

Test (C)

- Connect the output terminals with one another and measure with respect to PE

Table 7- 1 Test voltage

	Test time	Prim ↔ sec (A)	Prim ↔ PE (B)	Sec ↔ PE (C)
Type test	60 s	4200 VDC	2200 VDC	700 VDC
	60 s	3000 VAC	1500 VAC	500 VAC
Production test	1 s	2200 VDC	2200 VDC	500 VDC
	1 s	1500 VAC	1500 VAC	350 VAC
Field test	1 s	2200 VDC	2200 VDC	500 VDC
	1 s	1500 VAC	1500 VAC	350 VAC

Remark:

Tripping current for DC measurement: 0 mA

Tripping current for AC measurement: < 100 mA

## 7.3 Approvals

	<b>6EP1436-3BA10 (24 V/20 A)</b>	<b>6EP1456-3BA00 (48 V/10 A)</b>
CE marking	Yes, (2004/108/EG and 2006/95/EG)	Yes, (2004/108/EG and 2006/95/EG)
UL/cUL (CSA) approval	cULus-Listed (UL 508, CSA C22.2 No. 107.1), File E197259 cCSAus (CSA C22.2 No. 60950-1, UL 60950-1)	
Explosion protection	EPS 12 ATEX 1 442 X IECEX EPS 14.0062X II 3G Ex nA nC IIC T4 Gc cCSAus (CSA C22.2 No. 213, ANSI/ISA-12.12.01-2007)	
CB approval	Yes	Yes
SEMI F47 compliance	Fulfilled	-
Marine approvals	GL, ABS	GL, ABS

	<b>6EP1424-3BA00 (12 V / 20 A)</b>	<b>6EP1436-3BA20 (24 V / 17 A)</b>	<b>6EP1437-3BA20 (24 V / 30 A)</b>
CE marking	Yes, (2004/108/EG and 2006/95/EG)	Yes, (2004/108/EG and 2006/95/EG)	Yes, (2004/108/EG and 2006/95/EG)
UL/cUL (CSA) approval	cULus-Listed (UL 508, CSA C22.2 No. 107.1), File E197259	cULus-Listed (UL 508, CSA C22.2 No. 107.1), File E197259	cULus-Listed (UL 508, CSA C22.2 No. 107.1), File E197259
Marine approvals	-	GL	-

## 7.4 EMC

		<b>6EP1436-3BA10 (24 V / 20 A)</b> <b>6EP1456-3BA00 (48 V / 10 A)</b> <b>6EP1424-3BA00 (12 V / 20 A)</b> <b>6EP1436-3BA20 (24 V / 17 A)</b> <b>6EP1437-3BA20 (24 V / 30 A)</b>
Electrostatic discharge	EN 61000-4-2	8 kV contact, 8 kV air
Electromagnetic fields	EN 61000-4-3	80 ... 1000 MHz 25 V/m 1000 ... 2700 MHz 10 V/m
High-speed transient disturbances (burst)	EN 61000-4-4	4 kV at line supply connections, 2 kV at the DC output
Surge voltages	EN 61000-4-5	3 kV symmetrical at the line connections 6 kV unsymmetrical at the line connections 500 V symmetrical/unsymmetrical at DC output cables
High-frequency fields	EN 61000-4-6	10 V; 0.15 ... 80 MHz
Magnetic fields	EN 61000-4-8	30 A/m; 50 Hz
Emitted interference	EN 55022	Class B

---

6EP1436-3BA10 (24 V / 20 A)

6EP1456-3BA00 (48 V / 10 A)

6EP1424-3BA00 (12 V / 20 A)

6EP1436-3BA20 (24 V / 17 A)

6EP1437-3BA20 (24 V / 30 A)

---

Line harmonics limit	EN 61000-3-2	Class A
Generic standards	EN61000-6-2	Noise immunity for industrial environments
	EN61000-6-3	Emission for residential areas

---

## Ambient conditions

	6EP1436-3BA10 (24 V/20 A) 6EP1424-3BA00 (12 V/20 A) 6EP1436-3BA20 (24 V/17 A) 6EP1437-3BA20 (24 V/30 A)	6EP1456-3BA00 (48 V/10 A)
Ambient temperature	-25°...+70° C with natural convection	-10 ...+70° C with natural convection
	Tested according to: <ul style="list-style-type: none"> <li>• EN 60068-2-1 cold</li> <li>• EN 60068-2-2 dry heat</li> <li>• EN 60068-2-78 humid heat, constant</li> <li>• EN 60068-2-14 temperature change</li> </ul>	
Transport and storage temperature	-40 ...+85 °C	
	Tests (packed for shipping) according to: <ul style="list-style-type: none"> <li>• EN 60068-2-1 cold</li> <li>• EN 60068-2-2 dry heat</li> <li>• EN 60068-2-30 humid heat, cyclic</li> </ul>	
Humidity class	Climatic class 3K3 according to EN 60721, without condensation	
Mechanical stressing during operation	Tested according to: <ul style="list-style-type: none"> <li>• EN 60068-2-6 vibration, test Fc: 0.075 mm deflection in the range 10 ... 58 Hz 1 g acceleration in the range 58 ... 150 Hz</li> <li>• EN 60068-2-27 shock, test Ea: Acceleration 150 m/s<sup>2</sup>, test duration 11 ms</li> </ul>	

	6EP1436-3BA10 (24 V/20 A) 6EP1424-3BA00 (12 V/20 A) 6EP1436-3BA20 (24 V/17 A) 6EP1437-3BA20 (24 V/30 A)	6EP1456-3BA00 (48 V/10 A)
Damaging gases	Tested according to: <ul style="list-style-type: none"><li>• EN 60068-2-42 sulfur dioxide</li><li>• EN 60068-2-43 hydrogen sulfide</li></ul>	
Atmospheric pressure	Operation: <ul style="list-style-type: none"><li>• 1080 ... 795 hPa (-1000 ... +2000 m)</li><li>• For operation at altitudes of 2000 m up to 6000 m above sea level: output must be derated by -7.5 % / 1000 m or the ambient temperature must be reduced by 5 K / 1000 m (see Figure 4-6 Mounting height derating (Page 23))</li><li>• Overvoltage category: III to 2000 m (EN 50178) II from 2000 m to 6000 m (EN 50178) II to 2000 m (EN 60950-1) I from 2000 m to 6000 m (EN 60950-1)</li></ul> Storage: <ul style="list-style-type: none"><li>• 1080 ... 660 hPa (-1000 ...+3500 m)</li></ul>	

---



# Applications

## 9.1 Parallel connection to increase power rating

To increase the power rating, SITOP PSU300M/300B power supplies of the same type can be directly connected in parallel.

The following must be observed:

- The cables connected to each power supply at terminals "+" and "-" must have identical lengths and the same cable cross-sections (or the same impedance) up to a common external connection point (terminal strip) if possible.
- The power supplies connected in parallel must be switched on simultaneously with a common switch in the line feeder cable (e.g. with the main switch available in control cabinets).
- The output voltages measured in no-load operation for the power supplies that are not yet connected in parallel should not deviate more than a maximum of 50 mV. This usually corresponds to the factory setting. If the output voltage is changed, you should connect the "-" terminals and then, in no-load operation, measure the voltage difference between the "+" terminals that have not yet been connected. The voltage difference should not exceed 50 mV.
- Place selector switch A at "ON" (see Section Change-over switch (Page 15))

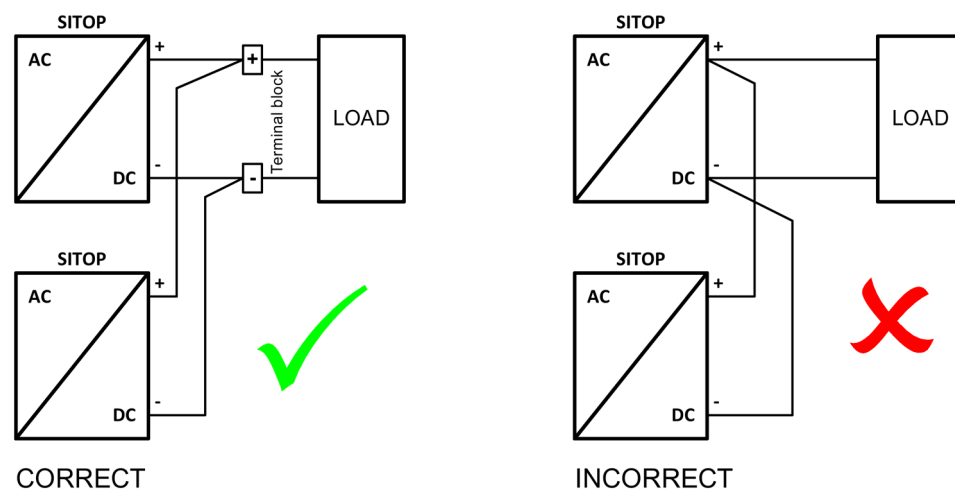

Figure 9-1 Parallel connection, correct and incorrect

**NOTICE**

**Protective circuit for the parallel connection of more than two power supplies**

When connecting more than two power supplies in parallel, additional measures must be taken to prevent high backward feeding currents in the event of a secondary device fault. For this purpose, a suitable protective circuit (e.g. decoupling diode or DC-conform circuit breaker) must be installed between each "+" terminal of the power supply and the common connection point.

## 9.2 Parallel connection for redundancy

Connecting several SITOP PSU300M/300B power supplies in parallel for redundancy purposes is required if especially high demands are placed regarding the availability of a reliable 24 V power supply.

Using the SITOP PSE202U redundancy module, two 24 V power supplies of the same type up to 20 A can be decoupled (Figure 9-2 Redundant configuration with two power supplies and one SITOP PSE202U redundancy module (Page 67)). When one of the devices fails, then the other automatically takes over the power supply. If one of the power supplies fails, then this is signaled using an LED on the redundancy module as well as an isolated relay contact.

For higher output current, each power supply must be connected to a redundancy module (Figure 9-3 Redundant configuration with two power supplies and two SITOP PSE202U redundancy modules (Page 68)).

When dimensioning the system, it must be ensured that  $n+1$  redundant connected power supplies can handle the total power requirement of the remaining  $n$  power supplies.

---

### Note

For a high reliability of the supply, it is recommended that the redundant switched power supplies are fused separately on the line-side and, if possible, be connected to different power supply networks.

---

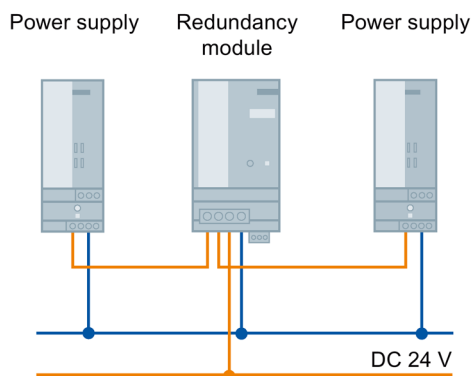

Figure 9-2 Redundant configuration with two power supplies and one SITOP PSE202U redundancy module

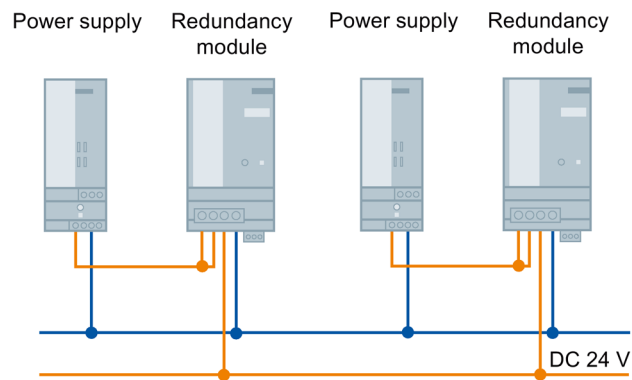

Figure 9-3 Redundant configuration with two power supplies and two SITOP PSE202U redundancy modules

You can find additional information at:

SITOP PSE202U manual (<http://support.automation.siemens.com/WW/view/en/42248598>)

## 9.3 Series connection for increased voltage

To achieve an output voltage of 48 V DC, two 24 V SITOP PSU300M/300M power supplies of the same type can be connected in series. In this case, connect the "-" terminal of the first power supply to the "+" terminal of the second power supply. The "+" terminal of the first power supply and the "-" terminal of the second power supply are routed to the load.

Depending on the grounding point of the secondary output voltages, voltages of +48 V,  $\pm 24$  V or -48 V can be realized.

In the case of an asymmetric load distribution, it is not possible to guarantee correct functionality.

### WARNING

#### SELV is not guaranteed in the case of a fault

When connecting two power supplies in series, the continuous, permissible SELV voltage of a maximum of 60 V DC according to EN 60950 cannot be guaranteed in the case of a fault.

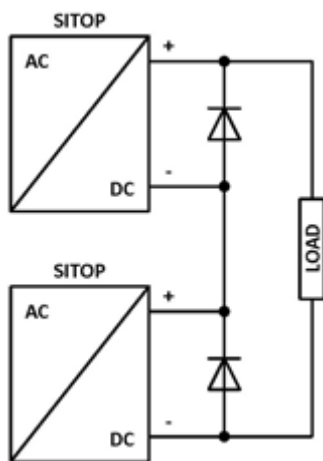

Figure 9-4 Series connection for increased voltage

## 9.4 Overload protection in the 24 V output circuit

If an overload occurs, the electronic current limiting function limits the SITOP PSU300M/300B output current to a maximum value (see Section Technical data (Page 39)). The output cables are protected against a thermal overload if they are dimensioned corresponding to the maximum rms output current, or protected using additional components (for example, miniature circuit breaker, fuses).

However, a load circuit that fails as a result of overload, for instance, should frequently be reliably and quickly identified and specifically switched off before the power supply goes into current-limiting mode (in current-limiting mode, the supply voltage would also be reduced for all of the remaining 24 V loads).

The SITOP PSE200U selectivity module with 4 outputs (versions with adjustable output current range for each output from 0.5 ... 3 A and 3 ... 10 A) is available; this monitors the 24 V branches for overload and short circuits (Figure 9-5 Selectivity module (Page 70)). Brief current peaks, e.g. as a result of a high inrush current, are permitted, and branches with a longer overload are switched into a no-current condition. This is also ensured for cables in a high-ohmic condition and for short-circuits that slowly develop over time.

When an output fails, the fault is signaled using a group signal contact or as a single channel signal, and the branch of the module involved is displayed using an LED.

For variants with single channel signaling, function blocks for evaluation purposes are available for SIMATIC S7-1200/1500/300/400, for STEP 7 Classic and TIA Portal at no charge.

You can find additional information at:

SITOP PSE200U selectivity module manuals

(<http://support.automation.siemens.com/WW/view/en/10807226/130000>)

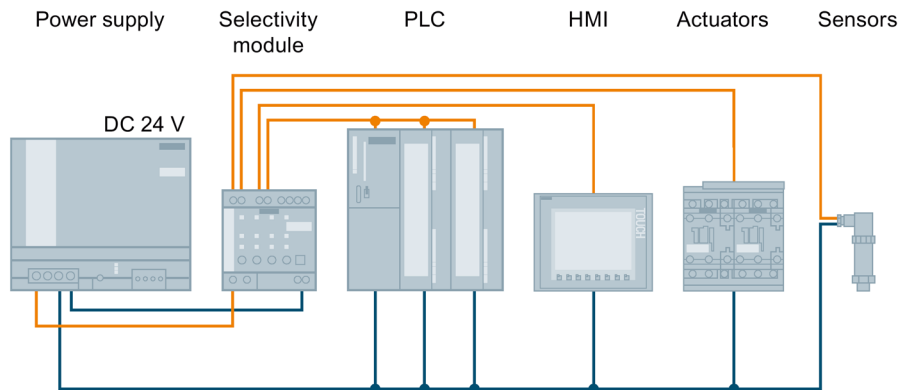

Figure 9-5 Selectivity module

## 9.5 Protection against short-time voltage dips

For a drop in the line-side supply voltage, the SITOP PSU300M/300B power supply still maintains the output voltage for a short time in the millisecond range (see Chapter Technical data (Page 39)).

For line supplies that manifest frequent brief voltage dips, in order to increase the power supply reliability, it may make sense to increase the line buffering time in the device using an additional SITOP PSE201U buffer module.

The SITOP PSE201U buffer module, based on electrolytic capacitors, is connected in parallel to the 24 V power supply output (Figure 9-6 Buffer module (Page 71)). The buffer time is 200 ms at 40 A up to 1.6 s for a load current of 5 A. This time can be increased a multiple number of times by connecting buffer modules in parallel; the maximum buffer time is 10 s.

You can find additional information at:

SITOP PSE201U manual (<http://support.automation.siemens.com/WW/view/en/41129219>)

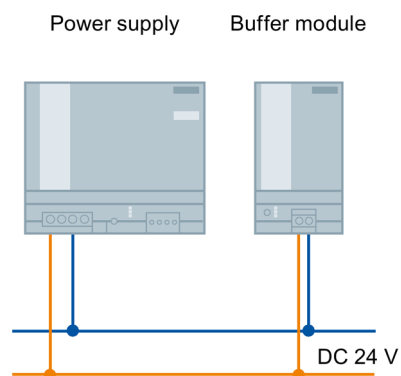

Figure 9-6 Buffer module

## 9.6 Protecting against longer power failures

Sudden and longer failures of the line supply voltage can result in undefined states and significant danger as a result of the associated failure of the plant or system control. The SITOP power supply product portfolio includes various DC-UPS solutions to prevent the failure of the 24 V power supply voltage.

Power supply failures up into the minutes range can be buffered using the maintenance-free SITOP UPS500 DC-UPS modules based on capacitors (Figure 9-7 24 V buffering to allow the saving of process data and controlled shutdown of PCs (Page 72)).

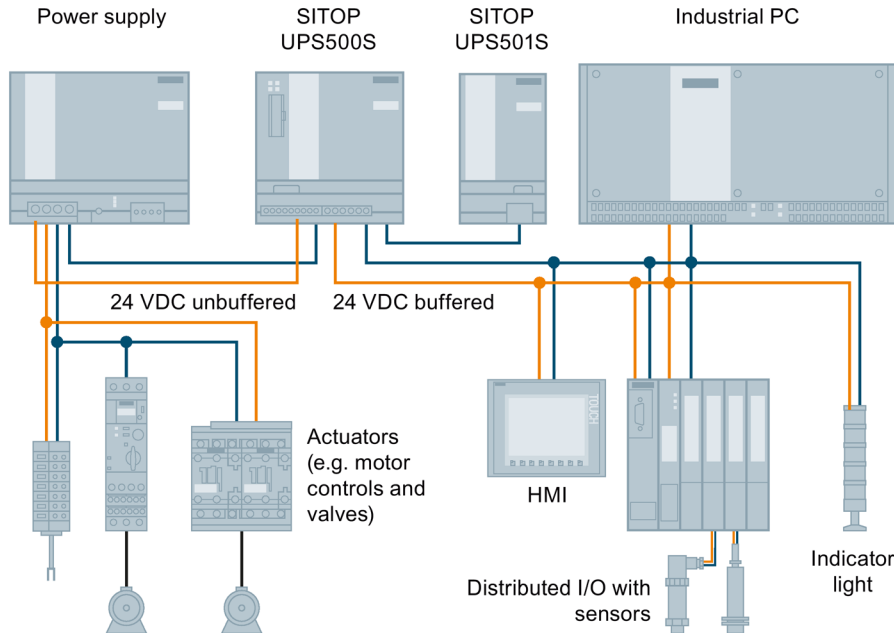

Figure 9-7 24 V buffering to allow the saving of process data and controlled shutdown of PCs

Using the free-of-charge SITOP DC-UPS software tool, DC-UPS systems can be simply integrated into PC-based automation solutions. This supports further processing of the status signals and safely running down the PC.

You can find additional information at:

Manual, DC UPS with capacitors

<http://support.automation.siemens.com/WW/view/en/48932766/133300>



Using DC UPS SITOP UPS1600 and SITOP UPS1100 battery modules, buffer times in the range of hours can be implemented. Intelligent battery management using Energy Storage Link automatically detects the UPS1100 energy storage device, and ensures optimum temperature-controlled charging and continuous monitoring. The UPS1600 can be flexibly integrated into the widest range of automation applications with its digital inputs/outputs as well as optional USB interface or Ethernet/PROFINET port.

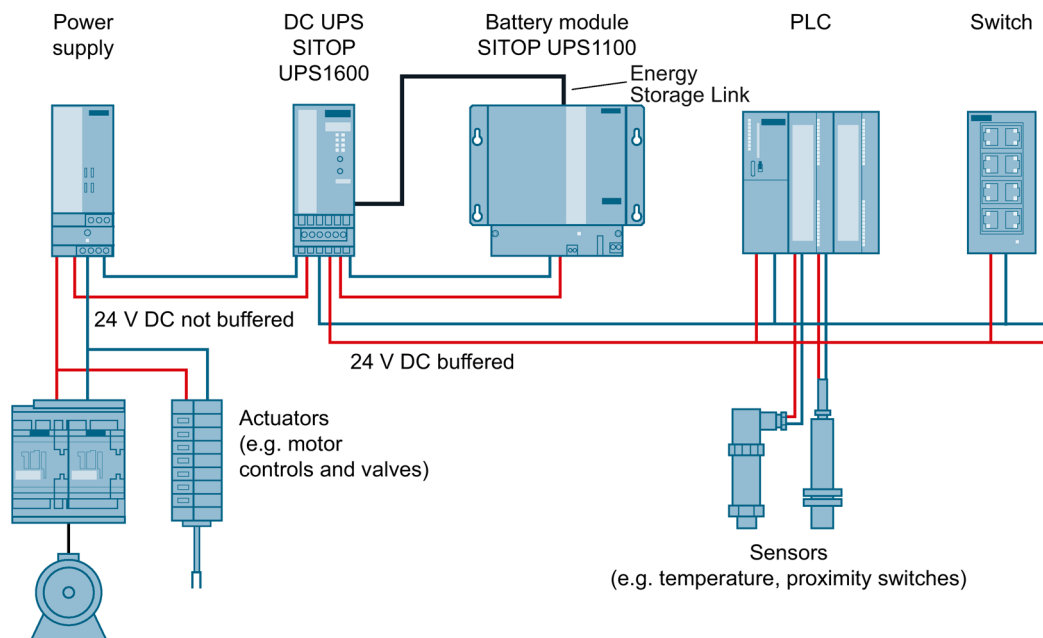

Figure 9-8 24 V buffering with SITOP UPS1600 to maintain communication, signaling functions, sensor measured values and position values

For open, PC-based automation systems, configuration and monitoring is realized using the SITOP UPS Manager PC software, which is available at no charge. This allows PC responses to the operating states of the DC UPS to be freely selected – and offers comprehensive diagnostic functions.

For TIA-based automation systems, the UPS1600 is engineered using the TIA Portal. Special function blocks for SIMATIC S7-300/400/1200 and S7-1500 – available at no charge – make it easy to integrate operating and diagnostics information into STEP 7 user programs. Preconfigured UPS faceplates for WinCC visualization can be downloaded at no charge.

You can find additional information at:

DC UPS SITOP UPS1600/UPS1100 Manual  
<http://support.automation.siemens.com/WW/view/en/84977415>

## 9.7 Battery charging with SITOP PSU300B

The SITOP PSU300B power supplies are optimized for charging lead accumulators. For a U-I characteristic curve set to parallel operation (DIP switch "A" at "ON", see Section Figure 2-6 Selector switch (example 6EP1456-3BA00 / 6EP1437-3BA20) (Page 15)), the battery to be charged is charged with a constant current until approximately 95% of the set SITOP output voltage is reached (set using a potentiometer, see Section Figure 2-4 Potentiometer (example 6EP1456-3BA00 / 6EP1437-3BA20) (Page 11)). The charging current then decreases continuously from  $1.2 \times$  rated current at 95% of the set voltage to approx. 0 A or the self-discharging current of the accumulator at 100% of the set output voltage, i.e. the resistance characteristic curve in this range (see Figure 6-10 6EP1424-3BA00 parallel operation output characteristic curve (Page 46), Figure 6-11 6EP1436-3BA20 parallel operation output characteristic curve (Page 47), Figure 6-12 6EP1437-3BA20 parallel operation output characteristic curve (Page 47)).

---

### Note

The value recommended by the battery manufacturer (dependent on the accumulator temperature) must be set as end-of-charge voltage. A lead accumulator temperature of  $+20^{\circ}$  to  $30^{\circ}$  C is ideal; in this case, the recommended end-of-charge voltage is normally approx. 13.5 or 27 V.

---

---

### Note

As protection against back e.m.f. and as polarity reversal protection, we recommend that a suitable diode for at least  $1.2 \times$  rated current of the power supply with at least 40 V blocking voltage is connected in series to the "+" output (connect the anode with "+" output of the SITOP PSU300B and the cathode with the plus pole of the accumulator). The output voltage of the power supply under no load must be set to the end-of-charge voltage plus the voltage drop at the diode. For an end-of-charge voltage of, for example, 27.0 VDC (usual for  $20^{\circ}$  C to  $30^{\circ}$  C accumulator temperature, although the specifications of the accumulator manufacturer must always be observed!) and 0.8 V voltage drop at the diode, the power supply without load should be set to 27.8 V.

---

LEDs and a potential-free signaling contact indicate the associated charge state of the battery (see Section Figure 2-5 Operating display and signaling (example 6EP1456-3BA00 / 6EP1437-3BA20) (Page 12)):

Green LED (12 V OK, 24 V OK) lights Signaling contact 13-14 closed	Battery voltage > approx. 10 V or > approx. 20 V
Yellow LED (overload) lights Signaling contact 13-14 open	Battery voltage < approx. 10 V or < approx. 20 V

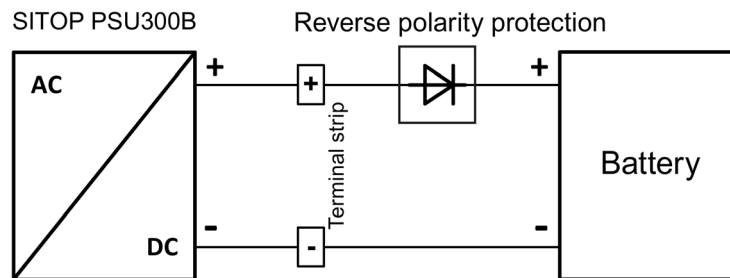

Figure 9-9 Battery charging with SITOP PSU300B

**⚠ WARNING**

The SITOP PSU300B power supply is a built-in device. It must be installed in a housing or control cabinet, to which only qualified personnel have access.

If SITOP is used as the battery charging device, the VDE 0510 regulations or the appropriate national regulations must be observed and an adequate ventilation of the battery location ensured.



## Environment

The devices are in conformance with RoHS.

As a rule, only non-silicon precipitating materials are used.

### Disposal guidelines



Packaging and packaging aids can and should always be recycled. The product itself may not be disposed of as domestic refuse.



## Service & Support

### Technical support

Technical support for all IA/DT products can be accessed through the following communication channels:

- Phone: + 49 (0) 911 895 7222
- E-Mail (<mailto:support.automation@siemens.com>)
- Internet:  
Online support request form (<http://www.siemens.de/automation/support-request>)

### Technical documentation on the Internet

Operating instructions and manuals for SITOP are available in the Internet:  
Operating instructions/manuals (<http://www.siemens.de/sitop/manuals>)

### SITOP power supply homepage

General news about our power supplies is available in the Internet at the SITOP homepage:  
SITOP (<http://www.siemens.de/sitop>)

### Information material

SITOP information can be downloaded from the Internet:  
Information and download center (<http://www.siemens.de/sitop-infomaterial>)

### CAX data

2D/3D data and circuit diagram macros can be downloaded from the Internet:  
Siemens image database (<http://www.siemens.de/sitop-cax>)

Request all CAX data via the CAX download manager:  
CAX shopping cart (<http://www.siemens.de/cax>)

### SITOP Selection Tool

Simply and quickly select the optimum the power supply or DC-UPS:  
SITOP Selection Tool (<http://www.siemens.de/sitop-selection-tool>)

### Online catalog and ordering system

The online catalog and the online ordering system are available through the Industry Mall homepage:  
Industry Mall (<http://www.siemens.com/industrymall/de>)

**Contact persons**

If you have any questions regarding the use of our products, then contact the Siemens contact person in your regional Siemens sales office.

You can find these addresses as follows:

- On the Internet (<http://www.siemens.de/automation/partner>)
- In Catalog CA 01