

SIEMENS

SIMATIC

ET 200S Distributed I/O System - Fail-Safe Modules

Hardware Installation and Operating Manual



The following supplement is part of this documentation:

No.	Designation	Drawing number	Edition
1	Product information	A5E00825271-01	07/2006

Preface

Product Overview

1

Configuring

2

Address Assignment and Installation

3

Wiring and Fitting Modules

4

Diagnostics

5

General technical specifications

6

Fail-Safe Modules

7

Diagnostic Data of Fail-Safe Modules

A

Dimension Drawings

B

Accessories and Order Numbers

C

Response Times

D

07/2005

A5E00103686-04

Safety Guidelines

This manual contains notices you have to observe in order to ensure your personal safety, as well as to prevent damage to property. The notices referring to your personal safety are highlighted in the manual by a safety alert symbol, notices referring only to property damage have no safety alert symbol. These notices shown below are graded according to the degree of danger.



Danger

indicates that death or severe personal injury **will** result if proper precautions are not taken.



Warning

indicates that death or severe personal injury **may** result if proper precautions are not taken.



Caution

with a safety alert symbol, indicates that minor personal injury can result if proper precautions are not taken.

Caution

without a safety alert symbol, indicates that property damage can result if proper precautions are not taken.

Notice

indicates that an unintended result or situation can occur if the corresponding information is not taken into account.

If more than one degree of danger is present, the warning notice representing the highest degree of danger will be used. A notice warning of injury to persons with a safety alert symbol may also include a warning relating to property damage.

Qualified Personnel

The device/system may only be set up and used in conjunction with this documentation. Commissioning and operation of a device/system may only be performed by **qualified personnel**. Within the context of the safety notes in this documentation qualified persons are defined as persons who are authorized to commission, ground and label devices, systems and circuits in accordance with established safety practices and standards.

Prescribed Usage

Note the following:



Warning

This device may only be used for the applications described in the catalog or the technical description and only in connection with devices or components from other manufacturers which have been approved or recommended by Siemens. Correct, reliable operation of the product requires proper transport, storage, positioning and assembly as well as careful operation and maintenance.

Trademarks

All names identified by ® are registered trademarks of the Siemens AG. The remaining trademarks in this publication may be trademarks whose use by third parties for their own purposes could violate the rights of the owner.

Disclaimer of Liability

We have reviewed the contents of this publication to ensure consistency with the hardware and software described. Since variance cannot be precluded entirely, we cannot guarantee full consistency. However, the information in this publication is reviewed regularly and any necessary corrections are included in subsequent editions.

Preface

Purpose of this Manual

The information in this manual is a reference source for operations, function descriptions, and technical specifications of the fail-safe modules of the ET 200S distributed I/O system.

Basic Knowledge Requirements

This manual is a supplement to the ET 200S Distributed I/O System manual. Working with this manual requires general knowledge of automation engineering. You also require experience of using the *STEP 7* basic software and the ET 200S distributed I/O system.

Scope of this Manual

Module	Order Number	Release Number and Higher
PM-E F pm DC24V PROFIsafe Power Module	6ES7 138-4CF02-0AB0	01
PM-E F pp DC24V PROFIsafe power module	6ES7 138-4CF41-0AB0	01
PM-D F DC24V PROFIsafe power module	3RK1 903-3BA01	01
4/8 F-DI DC24 V PROFIsafe Digital Electronic Module	6ES7 138-4FA02-0AB0	01
4 F-DO DC24V/2A PROFIsafe digital electronic module	6ES7 138-4FB02-0AB0	01

What's New

Compared with the previous version, this manual includes the following major changes/additions:

- Ability to connect ET 200S to PROFINET I/O (with modules as of order numbers above)
- New parameter "Behavior after channel faults"

Approvals

See Chapter "Standards and Approvals"

In addition, ET 200S fail-safe modules are certified for use in safety mode up to the following levels:

- Safety class SIL3 (Safety Integrity Level) in compliance with IEC 61508
- Requirement class 6 in accordance with DIN V 19250 (DIN V VDE 0801)
- Category 4 in accordance with EN 954-1

CE Approval

See Chapter "Standards and Approvals"

Certification Mark for Australia (C-Tick Mark)

See Chapter "Standards and Approvals"

Standards

See Chapter "Standards and Approvals"

Position in the Information Landscape

When working with ET 200S fail-safe modules and depending on your particular application, you will need to consult the additional documentation listed below.

References to additional documentation are included in this manual where appropriate.

Documentation	Brief Description of Relevant Contents
<i>ET 200S Distributed I/O system</i> manual	Describes all generally applicable topics related to the ET 200S hardware (including configuration, installing, and wiring of the ET 200S) and the IM 151 interface module.
<i>Safety Engineering in SIMATIC S7</i> system description	<ul style="list-style-type: none"> Provides an overview of the implementation, configuration, and method of operation of S7 Distributed Safety and S7 F/FH fail-safe automation systems Contains a summary of detailed technical information concerning fail-safe engineering in S7-300 and S7-400 Includes monitoring and response time calculations for S7 Distributed Safety and S7 F/FH F-systems
For integration in the S7 F/FH F-systems	<p>The <i>S7 F/FH Automation Systems</i> manual describes the tasks that must be performed to commission an S7 F/FH F-system.</p> <ul style="list-style-type: none"> The <i>S7-400, M7-400 Programmable Controllers Hardware and Installation</i> manual describes the installation and assembly of S7-400 systems. The <i>S7-400H Programmable Controllers, Fault-Tolerant Systems</i> manual describes the CPU 41x-H central modules and the tasks involved in setting up and commissioning an S7-400H fault-tolerant system. The <i>CFC for S7 Continuous Function Chart</i> manual/online help provides a description of programming with CFC.
For integration in the S7 Distributed Safety F-system	<p>The following elements are described in the <i>S7 Distributed Safety, Configuring and Programming</i> manual and online help:</p> <ul style="list-style-type: none"> Configuration of the fail-safe CPU and the fail-safe I/O Programming of the fail-safe CPU in fail-safe FBD or LAD <p>Depending on which F-CPU you use, you will need the following documentation:</p> <ul style="list-style-type: none"> The operating manual <i>S7-300, CPU 31xC and CPU 31x: Configuration</i> describes the configuration, installation, addressing and commissioning of S7-300 systems. The <i>CPU 31xC and CPU 31x, Technical Data</i> product manual describes the standard functions of the CPU 315F-2 DP and PN/DP and the CPU 317F-2 DP and PN/DP. The <i>Automation System S7-400 CPU Specifications</i> manual describes the standard functions of the CPU 416F-2. The <i>ET 200S IM 151-7 CPU Interface Module</i> manual describes the standard IM 151-7 CPU. A separate product information bulletin is available for each applicable F-CPU. The product information bulletins describe only the deviations from the corresponding standard CPUs.
<i>STEP 7</i> manuals	<ul style="list-style-type: none"> The <i>Configuring Hardware and Communication Connections with STEP 7 V5.x</i> manual describes the operation of the standard tools of STEP 7. The <i>System Software for S7-300/400 System and Standard Functions</i> reference manual describes functions for distributed I/O access and diagnostics.
<i>STEP 7</i> online help	<ul style="list-style-type: none"> Describes the operation of <i>STEP 7</i> standard tools Contains information about how to configure and assign parameters for modules and intelligent slaves with <i>HW Config</i> Contains a description of the programming languages FBD and LAD
<i>PCS 7</i> manuals	<ul style="list-style-type: none"> Describe how to operate the <i>PCS 7</i> process control system (required when ET 200S with fail-safe modules is integrated in a higher-level control system).

The entire SIMATIC S7 documentation is available on CD-ROM.

Guide

This manual describes the fail-safe modules of the ET 200S distributed I/O system. It consists of instructive sections and reference sections (technical specifications and appendices).

This manual presents the following basic aspects of fail-safe modules:

- Design and use
- Configuration and Parameter Assignment
- Addressing, assembly, and wiring
- Diagnostic assessment
- Technical Specifications
- Order numbers

Conventions

In this manual, the terms "safety engineering" and "fail-safe engineering" are used synonymously. The same applies to the terms "fail-safe" and "F-."

"S7 Distributed Safety" and *"S7 F Systems"* in italics refer to the optional packages for the two F-systems: "S7 Distributed Safety" and "S7 F/FH Systems".

Recycling and Disposal

Due to the low levels of pollutants in the fail-safe modules of the ET 200S, the modules can be recycled. For proper recycling and disposal of your old module (device), consult a certified disposal facility for electronic scrap.

Additional Support

If you have any additional questions about the use of products presented in this manual, contact your local Siemens representative:

<http://www.siemens.com/automation/partner>

Training center

We offer courses to help you get started with the S7 automation system. Contact your regional training center or the central training center in Nuremberg (90327), Federal Republic of Germany.

Telephone: +49 (911) 895-3200

Internet: <http://www.sitrain.com>

H/F Competence Center

The H/F Competence Center in Nuremberg offers special workshops on SIMATIC S7 fail-safe and redundant automation systems. The H/F Competence Center can also provide assistance with onsite configuration, commissioning, and troubleshooting.

Telephone: +49 (911) 895-4759

Fax: +49 (911) 895-5193

For questions about workshops, etc., contact: hf-cc@nbgm.siemens.com

Technical Support

You can reach the Technical Support for all A&D products

- Via the Web formula for the Support Request
<http://www.siemens.com/automation/support-request>
- Phone: + 49 180 5050 222
- Fax: + 49 180 5050 223

Additional information about our Technical Support can be found on the Internet pages
<http://www.siemens.com/automation/service>

Service & Support on the Internet

In addition to our paper documentation, we also provide all of our technical information on the Internet at:

<http://www.siemens.com/automation/service&support>

Here, you will find the following information:

- Newsletter providing the latest information on your products
- Exactly the right documents for your needs, which you can access by performing an online search in Service & Support
- Worldwide forum in which users and experts exchange ideas
- Your local contact for Automation & Drives.
- Information about local service, repair, and replacement parts. Much more information can be found under "Services" .

Important Note for Maintaining Operational Safety of Your System

Note

The operators of systems with safety-related characteristics must adhere to operational safety requirements. The supplier is also obliged to comply with special product monitoring measures. To keep you informed, a special newsletter is therefore available containing information on product developments and properties that are important (or potentially important) for operating systems where safety is an issue. By subscribing to the appropriate newsletter, you will ensure that you are always up-to-date and able to make changes to your system, when necessary. Point your browser to

<http://my.ad.siemens.de/myAnD/guiThemes2Select.asp?subjectID=2&lang=de>

There, you can register for the following newsletters:

- SIMATIC S7-300
- SIMATIC S7-400
- Distributed I/O
- SIMATIC Industrial Software

To receive these newsletters, select the "Updates" check box.

See also

Standards and Approvals (Page 6-2)

Table of contents

	Preface	iii
1	Product Overview	1-1
	1.1 Introduction	1-1
	1.2 ET 200S fail-safe modules	1-1
	1.3 Using ET 200S Fail-Safe Modules	1-2
	1.4 Guide for Commissioning of ET 200S with Fail-Safe Modules	1-5
2	Configuring	2-1
	2.1 Configuring ET 200S with Fail-Safe Modules	2-1
	2.2 Assigning Modules of an ET 200S	2-4
	2.3 Maximum Number of Connectable Modules/Maximum Configuration	2-6
	2.4 Configuration and Parameter Assignment	2-8
3	Address Assignment and Installation	3-1
	3.1 Address assignments in the F-CPU	3-1
	3.2 Assignment of the PROFIsafe address	3-3
	3.3 Installing	3-4
4	Wiring and Fitting Modules	4-1
	4.1 Introduction	4-1
	4.2 Safe Functional Extra Low Voltage for Fail-Safe Modules	4-2
	4.3 Wiring fail-safe modules	4-3
	4.4 Insertion and removal of fail-safe modules	4-4
	4.5 Requirements for Sensors and Actuators	4-6
5	Diagnostics	5-1
	5.1 Reactions to Faults	5-1
	5.2 Fault Diagnostics	5-3
6	General technical specifications	6-1
	6.1 Introduction	6-1
	6.2 Standards and Approvals	6-2
	6.3 Electromagnetic Compatibility	6-7
	6.4 Transport and storage conditions	6-11
	6.5 Mechanical and Climatic Environmental Conditions	6-12
	6.6 Specifications for Nominal Line Voltages, Isolation Tests, Protection Class, and Type of Protection	6-14

7	Fail-Safe Modules	7-1
7.1	Introduction	7-1
7.2	PM-E F pm DC24V PROFIsafe Power Module	7-2
7.2.1	Properties of the PM-E F pm DC24V PROFIsafe Power Module.....	7-2
7.2.2	Terminal assignment of the PM-E F pm DC24V PROFIsafe.....	7-8
7.2.3	Wiring of the PM-E F pm DC24V PROFIsafe	7-11
7.2.4	Parameters of the PM-E F pm DC24V PROFIsafe.....	7-15
7.2.5	Diagnostic functions of the PM-E F pm DC24V PROFIsafe	7-17
7.2.6	Technical Specifications for PM-E F pm 24 VDC PROFIsafe	7-20
7.3	PM-E F pp DC24V PROFIsafe power module.....	7-24
7.3.1	Properties of the PM-E F pp DC24V PROFIsafe Power Module.....	7-24
7.3.2	Terminal assignment of the PM-E F pp DC24V PROFIsafe.....	7-27
7.3.3	Wiring of the PM-E F pp DC24V PROFIsafe	7-29
7.3.4	Parameters of the PM-E F pp DC24V PROFIsafe.....	7-31
7.3.5	Diagnostic functions of the PM-E F pp DC24V PROFIsafe.....	7-32
7.3.6	Technical Specifications for the PM-E F pp 24 VDC PROFIsafe	7-34
7.4	PM-D F DC24V PROFIsafe power module.....	7-37
7.4.1	Properties of the PM-D F DC24V PROFIsafe Power Module.....	7-37
7.4.2	Terminal assignment of the PM-D F DC24V PROFIsafe.....	7-39
7.4.3	Wiring of the PM-D F DC24V PROFIsafe.....	7-41
7.4.4	Parameters of the PM-D F DC24V PROFIsafe.....	7-42
7.4.5	Diagnostic Functions of PM-D F DC24V PROFIsafe.....	7-42
7.4.6	Technical Specifications of the PM-D F DC24V PROFIsafe	7-45
7.5	4/8 F-DI VDC24V PROFIsafe Digital Electronic Module	7-47
7.5.1	Properties of the 4/8 F-DI 24 VDC PROFIsafe Digital Electronic Module	7-47
7.5.2	Terminal assignment of the EM 4/8 F-DI DC24V PROFIsafe.....	7-48
7.5.3	Wiring of the EM 4/8 F-DI 24 VDC PROFIsafe	7-50
7.5.4	Parameters of the EM 4/8 F-DI DC24V PROFIsafe	7-51
7.5.5	Applications for 4/8 F-DI 24 VDC PROFIsafe Digital Electronic Module	7-54
7.5.6	Application 1: Safety Mode AK4/SIL2/Category 3	7-56
7.5.7	Application 2: Safety Mode AK6/SIL3/Category 3	7-58
7.5.8	Application 3: Safety Mode AK6/SIL3/Category 4	7-69
7.5.9	Diagnostic Functions of the EM 4/8 F-DI 24 VDC PROFIsafe.....	7-74
7.5.10	Technical Specifications for the EM 4/8 F-DI 24 VDC PROFIsafe	7-77
7.6	4 F-DO DC24V/2A PROFIsafe digital electronic module.....	7-80
7.6.1	Properties of the 4 F-DO DC24V/2A PROFIsafe digital electronic module	7-80
7.6.2	Terminal assignment for EM 4 F-DO DC24V/2A PROFIsafe	7-82
7.6.3	Wiring diagram of the EM 4 F-DO DC24V/2A PROFIsafe.....	7-84
7.6.4	Parameters for the EM 4 F-DO DC24V/2A PROFIsafe	7-88
7.6.5	Diagnostic Functions of the EM 4 F-DO 24 VDC/2 A PROFIsafe	7-90
7.6.6	Technical Specifications of the EM 4 F-DO DC24V/2A PROFIsafe	7-93
A	Diagnostic Data of Fail-Safe Modules	A-1
A.1	Introduction	A-1
A.2	Structure and Content of Diagnostic Data	A-2
B	Dimension Drawings	B-1
C	Accessories and Order Numbers	C-1
D	Response Times	D-1
	Glossary	Glossary-1
	Index	Index-1

Tables

Table 1-1	Using Interface Modules in ET 200S with Fail-Safe Modules.....	1-4
Table 1-2	Achievable Safety Classes in Safety Mode	1-4
Table 1-3	Steps from Selecting the F-Modules to Commissioning ET 200S.....	1-5
Table 2-1	Assigning F-Power Modules to Terminal Modules	2-4
Table 2-2	Assigning F-Electronic Modules to Terminal Modules.....	2-4
Table 2-3	Assigning Power Modules to Electronic Modules/Motor Starters and Safety Class (Safety Integrity Level)	2-5
Table 2-4	Parameter Length of F-Modules in Bytes	2-6
Table 2-5	Maximum Configuration per Voltage Group	2-7
Table 3-1	Address assignment in the F-CPU.....	3-1
Table 3-2	Addresses Occupied by Useful Data	3-2
Table 4-1	Conditions for Inserting and Removing Fail-Safe Modules During Operation.....	4-5
Table 4-2	Minimum Duration of the Sensor Signals to Allow Correct Acquisition by the F-DI Module	4-7
Table 5-1	Channel-Specific Diagnostics: Fault Types of Fail-Safe Modules.....	5-6
Table 7-1	Overview of Achievable Safety Classes (Safety Integrity Levels) with PM-E F pm DC24V PROFIsafe	7-2
Table 7-2	PM-E F pm DC24V PROFIsafe: Conditions for AK/SIL/Category.....	7-3
Table 7-3	Table-Terminal Assignment of the TM-P30S44-A0 or TM-P30C44-A0.....	7-10
Table 7-4	Parameters of the PM-E F pm DC24V PROFIsafe.....	7-15
Table 7-5	Diagnostic functions of the PM-E F pm DC24V PROFIsafe	7-17
Table 7-6	Causes of Errors and Corrective Measures for Diagnostic Messages of the PM-E F pm 24 VDC PROFIsafe	7-18
Table 7-7	Overview of Achievable Safety Classes (Safety Integrity Levels) with PM-E F pp DC24V PROFIsafe	7-24
Table 7-8	PM-E F pp DC24V PROFIsafe: Conditions for AK/SIL/Category.....	7-25
Table 7-9	Table-Terminal Assignment of the TM-P30S44-A0 or TM-P30C44-A0.....	7-28
Table 7-10	Parameters of the PM-E F pp DC24V PROFIsafe.....	7-31
Table 7-11	Diagnostic functions of the PM-E F pp DC24V PROFIsafe	7-32
Table 7-12	Causes of Faults and Corrective Measures for Diagnostic Messages of the PM-E F pp 24 VDC PROFIsafe	7-33
Table 7-13	PM-D F DC24V PROFIsafe: Conditions for AK/SIL/Category.....	7-38
Table 7-14	Terminal Assignment of the TM-PF30S47-F1	7-40
Table 7-15	Parameters of the PM-D F DC24V PROFIsafe	7-42
Table 7-16	Diagnostic Functions of PM-D F DC24V PROFIsafe.....	7-43
Table 7-17	Causes of Faults and Corrective Measures for Diagnostic Messages of the PM-D F DC24V PROFIsafe	7-44
Table 7-18	EM 4/8 F-DI DC24V PROFIsafe: Power Modules for AK/SIL/Category.....	7-47
Table 7-19	Parameters of the EM 4/8 F-DI DC24V PROFIsafe	7-51

Table of contents

Table 7-20	EM 4/8 F-DI DC24V PROFIsafe: Conditions for Achieving AK/SIL/Category	7-55
Table 7-21	EM 4/8 F-DI DC24V PROFIsafe: Fault Detection (Application 1).....	7-57
Table 7-22	EM 4/8 F-DI DC24V PROFIsafe: Fault Detection (Application 2.1).....	7-61
Table 7-23	EM 4/8 F-DI DC24V PROFIsafe: Fault Detection (Application 2.2).....	7-64
Table 7-24	EM 4/8 F-DI DC24V PROFIsafe: Fault Detection (Application 2.3).....	7-68
Table 7-25	EM 4/8 F-DI DC24V PROFIsafe: Fault detection (use cases 3.1 and 3.2).....	7-73
Table 7-26	Diagnostic Functions of the EM 4/8 F-DI 24 VDC PROFIsafe.....	7-74
Table 7-27	Diagnostic Messages of the EM 4/8 F-DI DC24V PROFIsafe, Causes of Faults and Corrective Measures	7-75
Table 7-28	EM 4 F-DO DC24V/2A PROFIsafe: Power Modules for AK/SIL/Category	7-80
Table 7-29	Parameters of the F-DO module	7-88
Table 7-30	Diagnostic Functions of the EM 4 F-DO 24 VDC/2 A PROFIsafe	7-90
Table 7-31	Diagnostic Messages of the EM 4 F-DO DC24V/2A PROFIsafe, Causes of Errors and Corrective Measures	7-91
Table A-1	SFCs for Reading out Diagnostic Data	A-2
Table D-1	PM-E F pm DC24V PROFIsafe: Internal processing times of the electronic PM channel.....	D-1
Table D-2	PM-E F pm DC24V PROFIsafe: Internal processing times of the P1/2 channel	D-2
Table D-3	PM-E F pp DC24V PROFIsafe: Internal preparation times	D-2
Table D-4	PM-D F DC24V PROFIsafe: Internal preparation times	D-2
Table D-5	EM 4/8 F-DI DC24V PROFIsafe: Internal preparation times	D-3
Table D-6	EM 4/8 F-DI DC24V PROFIsafe: Maximum Response Time if a Fault Occurs:	D-3
Table D-7	EM 4 F-DO DC24V/2A PROFIsafe: Internal preparation times	D-4

Product Overview

1.1 Introduction

Overview

This chapter provides information about the following topics:

- ET 200S distributed I/O system with fail-safe modules and its place in SIMATIC S7 fail-safe automation systems
- Components comprising the ET 200S distributed I/O system with fail-safe modules
- The steps you must perform, ranging from selection of the F-modules to commissioning of ET 200S on PROFIBUS DP/PROFINET IO

1.2 ET 200S fail-safe modules

Fail-safe automation system

Fail-safe automation systems (F-systems) are used in systems with higher-level safety requirements. F-systems are used to control systems having a safe state immediately after shutdown. That is, F-systems control processes in which an immediate shutdown does not endanger humans or the environment.

ET 200S distributed I/O system

The ET 200S distributed I/O system is a DP slave/IO device on PROFIBUS DP/PROFINET IO that can contain fail-safe modules in addition to ET 200S standard modules.

You can use copper cable or fiber-optic cable to assemble the PROFIBUS DP/PROFINET IO lines.

Fail-Safe Modules

The major difference between fail-safe modules and standard ET 200S modules is that fail-safe modules have a two-channel internal design. Both integrated processors monitor each other, automatically test the input and output wiring, and place the F-module in a safe state in the event of a fault. The F-CPU communicates with the fail-safe module using the PROFIsafe safety-related bus profile.

Fail-safe power modules supply load voltage to the potential group and safely shut down the load voltage for output modules.

Fail-safe digital input modules record the signal states of safety-related sensors and send corresponding safety message frames to the F-CPU.

Fail-safe digital output module are suitable for shutdown procedures with short-circuit and cross-circuit protection up to the actuator.

1.3 Using ET 200S Fail-Safe Modules

Possible Uses of ET 200S with Fail-Safe Modules

The use of ET 200S with fail-safe modules enables conventional safety engineering designs to be replaced with PROFIBUS DP/PROFINET IO components. This includes replacement of switching devices for emergency stop, protective door monitors, two-hand operation, etc.

Use in F-systems

Fail-safe ET 200S modules can be used:

- In the *S7 Distributed Safety* F-system with *S7 Distributed Safety* optional package V5.4 or higher
- In *S7 F/FH Systems* with the *S7 F Systems* optional package as of version V5.2 SP 2
- To connect ET 200S fail-safe modules to PROFINET IO modules with Distributed Safety, you need:
 - ET 200S fail-safe modules as of the order numbers specified in "Preface"
 - CPU 315F-2 PN/DP or CPU 317F-2 PN/DP
 - *STEP 7* V5.3 SP 3 or higher
 - IM 151-3 PN HIGH FEATURE interface module
 - *S7 Distributed Safety* V5.4 or higher (*F Configuration Pack* V5.4 or higher)

When using fail-safe ET 200S I/O modules in F-systems, the information in the following manuals applies:

- *ET 200S distributed I/O system*
- *Safety Engineering in SIMATIC S7*
- *S7 Distributed Safety, Configuration and Programming or Programmable Controllers S7 F/FH Systems*

F-System with ET 200S

The following figure presents an example configuration for an S7 Distributed Safety F-system including an ET 200S on PROFIBUS DP/PROFINET IO.

The fail-safe DP master/IO controller exchanges safety-relevant and non-safety-relevant data with the fail-safe and standard ET 200S modules, etc.

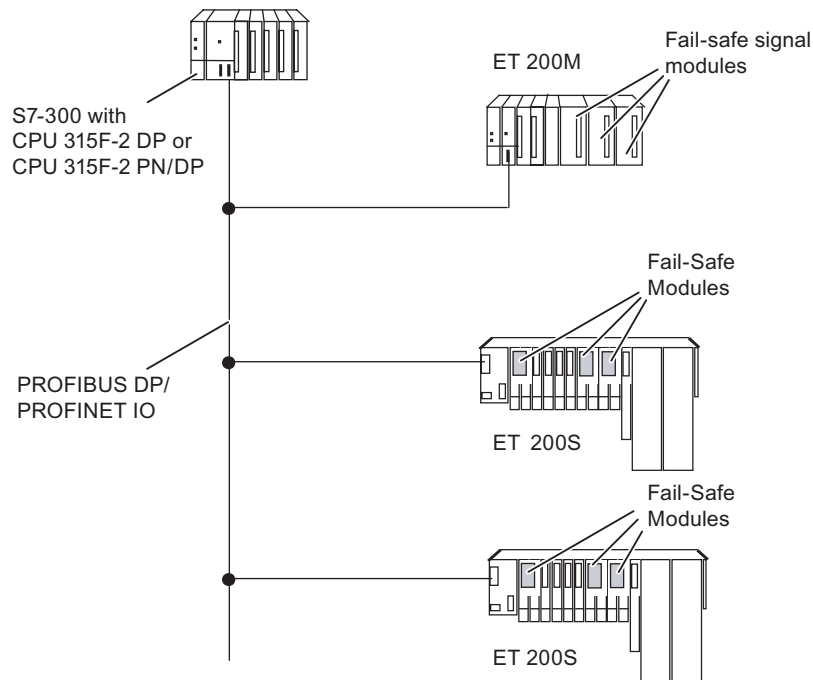

Figure 1-1 S7 Distributed Safety Fail-Safe Automation System (Example Configuration)

Availability of Fail-Safe Electronic Modules

The following fail-safe electronic modules are available for ET 200S:

- PM-E F pm DC24V PROFIsafe power module; P/M switching (current sourcing/sinking), with 2 additional, fail-safe digital outputs
- PM-E F pp DC24V PROFIsafe power module; P/P switching (current sourcing)
- PM-D F DC24V PROFIsafe power module; P/P switching (current sourcing)
- 4/8 F-DI VDC24V PROFIsafe Digital Electronic Module
- 4 F-DO DC24V/2A PROFIsafe digital electronic module; P/M switching (current sourcing/sinking)

The PM-D F DC24V PROFIsafe is used for partial shutdowns of fail-safe motor starters via six fail-safe shutdown groups.

A range of terminal modules is available for fail-safe power and electronic modules. You will find a detailed list in this manual.

Using Interface Modules in ET 200S with Fail-Safe Modules

Depending on the F system, select the interface module for ET 200S as follows:

Table 1-1 Using Interface Modules in ET 200S with Fail-Safe Modules

Interface module	As of order number	Can be used in ET 200S with optional package	As of version
IM151-1 HIGH FEATURE * for PROFIBUS DP connection	6ES7 151-1BA00-0AB0	<i>S7 Distributed Safety</i>	V 5.1
		<i>S7 F Systems</i>	V 5.2
IM 151-7 F-CPU ** for PROFIBUS DP connection	6ES7 151-7FA00-0AB0	<i>S7 Distributed Safety</i>	V 5.2
IM 151-3 PN HIGH FEATURE for PROFINET IO connection	6ES7 151-3AB00-0AB0	<i>S7 Distributed Safety</i>	V5.4
*: V1.1.1 or higher for use with PM-E F pp DC24V PROFIsafe power module			
**: V2.0.6 or higher for use with PM-E F pp DC24V PROFIsafe power module			

The IM151-1 HIGH FEATURE and the IM 151-3 PN HIGH FEATURE are described in the *ET 200S Distributed I/O System* manual; the IM 151-7 F-CPU is described in a separate product information bulletin.

Use in Safety Mode Only

Fail-safe modules can only be used in safety mode. They cannot be used in standard mode.

Achievable Safety Classes

Fail-safe modules are equipped with integrated safety functions for safety mode.

The following safety classes can be achieved in safety mode by assigning appropriate parameters to the safety functions in *STEP 7* with the *S7 Distributed Safety* or *S7 F Systems* optional package, by combining certain standard and F-modules and by arranging the wiring of the sensors and actuators in a specific way:

Table 1-2 Achievable Safety Classes in Safety Mode

Safety Class in Safety Mode		
In accordance with IEC 61508	In accordance with DIN V 19250	In Accordance with EN 954-1
SIL2	AK4	Category 3
SIL3	AK6	Category 3
SIL3	AK6	Category 4

See also

Configuring ET 200S with Fail-Safe Modules (Page 2-1)

1.4 Guide for Commissioning of ET 200S with Fail-Safe Modules

Introduction

The following table lists all important steps required for commissioning ET 200S distributed I/O systems with fail-safe modules as DP slaves/IO devices on PROFIBUS DP/PROFINET IO.

Steps from Selecting the F-Modules to Commissioning ET 200S

Table 1-3 Steps from Selecting the F-Modules to Commissioning ET 200S

Step	Procedure	See ...
1.	Select F-modules for ET 200S configuration	"Configuration Options" chapter
2.	Configure and assign parameters to F-modules in <i>STEP 7</i>	"Configuration and Parameter Assignment" and "Fail-Safe Modules" chapters
3.	Set PROFIsafe addresses on F-modules	"Address Assignment and Installation" chapter
4.	Mount ET 200S	"Address Assignment and Installation" chapter
5.	Wire ET 200S	"Wiring and Fitting Modules" chapter
6.	Commission ET 200S on PROFIBUS DP/PROFINET IO	<i>ET 200S Distributed I/O system</i> manual
7.	If commissioning was not successful, perform diagnostics on ET 200S	"Diagnostics" chapter, "Fail-Safe Modules" chapter and <i>ET 200S Distributed I/O System</i> manual

Note

You must configure and assign parameters to the F-modules in *STEP 7* before commissioning.

This is required because the PROFIsafe addresses of F-modules are assigned automatically by *STEP 7*. You must set these PROFIsafe addresses on each F-module by means of switches before mounting the module.

Configuring

2.1 Configuring ET 200S with Fail-Safe Modules

Introduction

You can configure ET 200S distributed I/O systems with standard and fail-safe modules. This chapter presents an example configuration.

Configuration Example of ET 200S with Fail-Safe Modules

In the following figure you will find a configuration example using standard and fail-safe modules in an ET 200S. You must divide and mount the modules in fail-safe voltage groups and standard voltage groups. A new voltage group always begins with a power module.

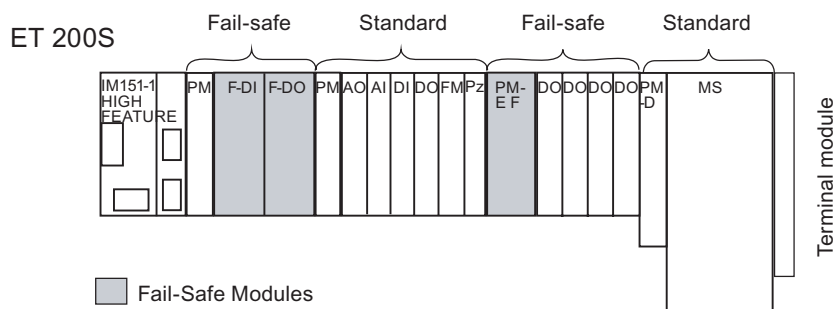

Figure 2-1 Configuration Example of ET 200S with Fail-Safe Modules



Warning

Please note that for **AK6/SIL3/Category 4**, mixing F-DI/F-DO modules and standard DI-/DO-/FM modules **within a voltage group** is **not** permitted.

For **AK4/SIL2/Category 3**, mixing F-DI/F-DO modules and standard DI-/ DO-/FM modules within a voltage group is permitted.

Configuration Rules for Fail-Safe Voltage Groups

The "Assignment of Power Modules to Electronic Modules/Motor Starters and Safety Class" table presents all of the fail-safe and standard power and electronic modules that you can use in a voltage group.

Configuration with Fail-Safe Motor Starters and Frequency Converters

Use a PM-D F DC24V PROFIsafe for the selective shutdown of:

- fail-safe motor starters (F-MS) F-DS1e-x, F-RS1e-x
- SINAMICS fail-safe frequency converters (F-FU) with ICU24(F)
- fail-safe F-CM connection multipliers
- PM-D F X1 fail-safe power/expansion modules.

The PM-D F DC24V PROFIsafe cannot supply other motor starters (for example DS1-x/RS1-x, DS1e-x/RS1e-x, DSS1e-x).

The fail-safe motor starters can be expanded:

- up to safety class (safety integrity level) AK6/SIL3/Category 4 with the Brake Control xB1, xB2 expansion modules
- up to safety class (safety integrity level) AK4/SIL2/Category 3 with the Brake Control xB3, xB4 expansion modules

Example of a Configuration with Fail-Safe Motor Starters

The following figure shows an example of an ET 200S configuration with two fail-safe voltage groups. The first voltage group contains fail-safe motor starters and a connection multiplier. This configuration achieves safety class (safety integrity level) AK6/SIL3/Category 4.

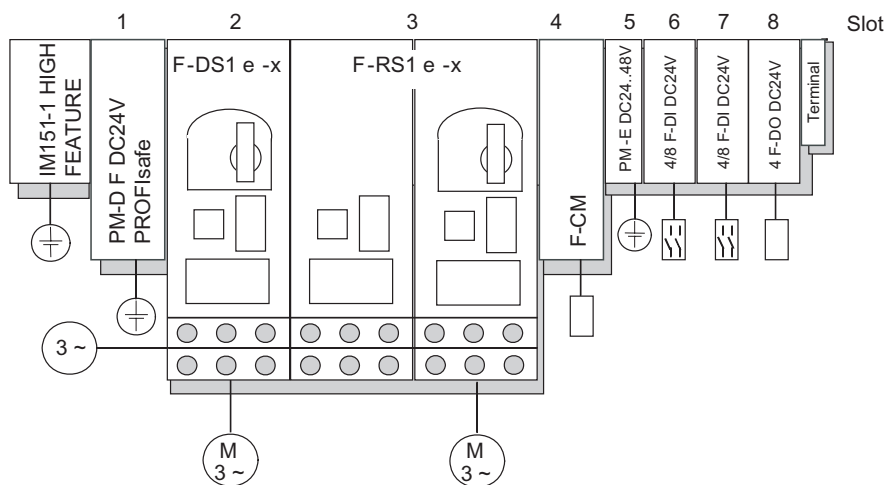

Figure 2-2 Example of an ET 200S Configuration with Fail-Safe Motor Starters and Connection Multiplier

More Detailed Information on Fail-Safe Motor Starters

All submodules and modules that can be supplied by the PM-D F DC24V PROFIsafe are described in the *ET 200S Motor Starter* manual.

This manual is part of the ET 200S documentation package, order no. 6ES7 151-1AA10-8xA0.

Positioning and Connecting Power Modules

An ET 200S containing fail-safe modules is no different than an ET 200S containing standard modules with regard to positioning and connection of power modules.

You can position the power modules as you wish. Each TM-P terminal module (for a power module) that you add to the ET 200S opens a new voltage group. All sensor and load current supplies of the electronic modules/motor starters that follow are fed from this terminal module.

Placing another TM-P terminal module after an electronic module/motor starter interrupts the voltage buses (P1/P2) and simultaneously opens a new voltage group. This enables individual connection of sensor and load current supplies.

AUX(iliary) Bus (AUX 1)

A TM-P terminal module (for a power module) allows an additional voltage connection (up to the maximum rated load voltage of the module), which you can apply over the AUX(iliary) bus. You can use the AUX(iliary) voltage as follows:

- As a protective conductor bus
- When additional voltage is required

Additional Information about Positioning and Connecting Power Modules

You will find additional information about positioning and connecting power modules in the *ET 200S Distributed I/O System* manual.

2.2 Assigning Modules of an ET 200S

Introduction

This section presents the following module assignments for ET 200S:

- F-power modules to terminal modules
- F-electronic modules to terminal modules
- Power modules to electronic modules/motor starters

Assigning F-Power Modules to Terminal Modules

You can use the F-power modules with the following terminal modules:

Table 2-1 Assigning F-Power Modules to Terminal Modules

F-Power Modules	Terminal Modules	For a Description, See ...
PM-E F pm DC24V PROFIsafe and PM-E F pp DC24V PROFIsafe	TM-P30S44-A0 (screw-in type) TM-P30C44-A0 (snap-in type)	<i>ET 200S Distributed I/O system manual</i>
PM-D F DC24V PROFIsafe	TM-PF30S47-F1 (screw-in type)	

Assigning F-Electronic Modules to Terminal Modules

You can use the following fail-safe electronic modules and terminal modules together:

Table 2-2 Assigning F-Electronic Modules to Terminal Modules

F-Electronic Modules	Terminal Modules	For a Description, See ...
4/8 F-DI DC24V PROFIsafe and 4 F-DO DC24V/2A PROFIsafe	TM-E30S46-A1 (screw-in type) TM-E30C46-A1 (snap-in type) TM-E30S44-01 (screw-in type) TM-E30C44-01 (snap-in type)	<i>ET 200S Distributed I/O system manual</i>

Assigning Power Modules to Electronic Modules/Motor Starters

You can use the power modules and electronic modules/motor starters in the following table within a voltage group.

Note that certain combinations limit the achievable safety classes.

Table 2-3 Assigning Power Modules to Electronic Modules/Motor Starters and Safety Class (Safety Integrity Level)

Power Modules	Reference	Electronic Module/Motor Starter	Use and Achievable AK/SIL/Category	
PM-E F pm DC24V PROFIsafe	"PM-E F pm DC24V PROFIsafe power module"	Can be used with all standard electronic modules	Safe shutdown of DO modules from the ET 200S range	
PM-E F pp DC24V PROFIsafe	"PM-E F pp DC24V PROFIsafe power module"			
PM-D F DC24V PROFIsafe	"PM-D F DC24V PROFIsafe power module"	Can only be used for: <ul style="list-style-type: none"> F-DS1e-x, F-RS1e-x fail-safe motor starters (F-MS) connection multiplier F-CM PM-D F X1 power/ expansion module Expansion modules Brake Control xB1 and xB2	Safe shutdown of motor starters	AK6/ SIL3/ Category 4
		Can be used for the F-motor starters indicated above: Brake Control xB3 and xB4 expansion modules	Safe shutdown of motor starters	AK4/ SIL2/ Category 3
PM-E DC24V	<i>ET 200S</i> manual	Can be used with all standard and fail-safe electronic modules	Supply of F-DI modules and F-DO modules	AK4/ SIL2/ Category 3
PM-E DC24..48V	<i>ET 200S</i> manual	Can be used with all standard and fail-safe electronic modules	Supply of F-DI modules and F-DO modules	AK6/ SIL3/ Category 4
PM-E DC24..48V/ DC24..230V				

See also

Properties of the PM-E F pm DC24V PROFIsafe Power Module (Page 7-2)

Properties of the PM-E F pp DC24V PROFIsafe Power Module (Page 7-24)

Properties of the PM-D F DC24V PROFIsafe Power Module (Page 7-37)

2.3 Maximum Number of Connectable Modules/Maximum Configuration

Maximum Number of Modules

The modules include the interface module, power and electronic modules, and motor starters.

The total width of an ET 200S is limited to 1 m. In addition, the maximum number of modules in an ET 200S depends on the parameter length of the modules. A total of 244 bytes per ET 200S are possible.

Table 2-4 Parameter Length of F-Modules in Bytes

Fail-Safe Module	Parameter Length
PM-E F pm DC24V PROFIsafe	22 Byte
PM-E F pp DC24V PROFIsafe	20 Byte
PM-D F DC24V PROFIsafe	20 Byte
4/8 F-DI DC24V PROFIsafe	30 Byte
4 F-DO DC24V/2A PROFIsafe	22 Byte

Example

The following example shows modules that have been used with a parameter length of a total of 224 bytes in an ET 200S. There are also 20 bytes available for installation of additional modules.

Number and type of modules	: 1 x IM151-1 HIGH FEATURE	+ 1 x PM-E DC24V/AC24V..230V	+ 5 x F-DI module*	+ 2 x F-DO module**	= 9 modules
----------------------------	----------------------------	------------------------------	--------------------	---------------------	-------------

Parameter length	: 27 byte***	+ 3 Byte	+ 150 Byte	+ 44 Byte	= 224 Byte
------------------	--------------	----------	------------	-----------	------------

* 5 F-DI modules are available: 20 SIL3 or 40 SIL2 inputs

** 2 F-DO modules are available: 8 SIL2/SIL3 outputs

*** 56 bytes with clocking

Power Modules: Maximum Configuration per Voltage Group

Table 2-5 Maximum Configuration per Voltage Group

Power Modules	Maximum Current Carrying Capacity	Connectable Modules/Motor Starters
PM-E F pm DC24V PROFIsafe	10 A	The number of modules that can be connected depends on the total current of all modules in the voltage group. The total combined current cannot exceed 10 A. The total current is determined by the digital output modules.
PM-E F pp DC24V PROFIsafe		
PM-D F DC24V PROFIsafe	10 A briefly* 5 A permanent*	The number of connectable motor starters/modules depends on the total current of all motor starters/modules of this voltage group. The total combined current cannot exceed 10 A.

* Reason:	Current consumption of the F-motor starters	
	U1 (electronics supply)	SG (shutdown groups)
Switching time (up to 200 ms)	0.15 A	0.25 A
Duration (to 200 ms)	0.15 A	0.06 A

ET 200S: Limitations and maximum configuration

You will find information on the limitations and maximum configuration of the standard ET 200S in the *ET 200S Distributed I/O System* manual.

2.4 Configuration and Parameter Assignment

Prerequisite

The following are required for configuring and assigning parameters for ET 200S fail-safe modules:

- *STEP 7* V5.1 SP 6 or higher (for PROFINET connection: STEP 7, V5.3 SP 3 or higher)
- *S7 Distributed Safety* V5.4 or higher (*F Configuration Pack* V5.4 or higher)
- *S7 F Systems*, Version V5.2 SP 2 or higher

The *F Configuration Pack* can be downloaded from the Internet from:
<http://www.siemens.com/automation/service&support>

Configuring

Follow the usual procedure with *STEP 7 HW Config* to configure fail-safe modules (in the same way as standard ET 200S modules).

Parameter Assignment for Module Properties

To assign parameters for fail-safe module properties, select the module in *STEP 7 HW Config* and select the menu command "Edit > Object Properties".

Parameters are downloaded from the programming device to the F-CPU, where they are stored and then transferred to the fail-safe module.

Parameter description

You will find a description of assignable fail-safe module parameters in this manual.

PROFIsafe Address and PROFIsafe Address Assignment

You can find a description of PROFIsafe addresses and the address assignment procedure in this manual.

See also

Assignment of the PROFIsafe address (Page 3-3)

Parameters of the PM-E F pm DC24V PROFIsafe (Page 7-15)

Parameters of the PM-E F pp DC24V PROFIsafe (Page 7-31)

Parameters of the PM-D F DC24V PROFIsafe (Page 7-42)

Parameters of the EM 4/8 F-DI DC24V PROFIsafe (Page 7-51)

Parameters for the EM 4 F-DO DC24V/2A PROFIsafe (Page 7-88)

Address Assignment and Installation

3.1 Address assignments in the F-CPU

Address Assignment

The fail-safe modules occupy the following address ranges in the F-CPU:

- for S7 Distributed Safety: in the area of the process image
- for S7 F/FH systems: in the area of the process image

Table 3-1 Address assignment in the F-CPU

F-Module	Occupied Bytes in the F-CPU:	
	In Input Range	In Output Range
PM-E F pm DC24V PROFIsafe	x + 0 to x + 4	x + 0 to x + 4
PM-E F pp DC24V PROFIsafe	x + 0 to x + 4	x + 0 to x + 4
PM-D F DC24V PROFIsafe	x + 0 to x + 4	x + 0 to x + 4
4/8 F-DI DC24V PROFIsafe	x + 0 to x +5	x + 0 to x +3
4 F-DO DC24V/2A PROFIsafe	x + 0 to x + 4	x + 0 to x + 4
x = Module start address		

Addresses Occupied by Useful Data

The useful data occupy the following addresses of the assigned addresses of the fail-safe modules in the F-CPU:

Table 3-2 Addresses Occupied by Useful Data

Byte in the F-CPU	Occupied Bits in F-CPU per F-Module:							
	7	6	5	4	3	2	1	0
PM-E F pm DC24V PROFIsafe:								
x + 0	-	-	-	-	-	Channel 2	Channel 1	Channel 0
PM-E F pp DC24V PROFIsafe:								
x + 0	-	-	-	-	-	-	-	Channel 0
PM-D F DC24V PROFIsafe:								
x + 0	-	-	Channel 5	Channel 4	Channel 3	Channel 2	Channel 1	Channel 0
4/8 F-DI DC24V PROFIsafe:								
x + 0	Channel 7	Channel 6	Channel 5	Channel 4	Channel 3	Channel 2	Channel 1	Channel 0
4 F-DO DC24V/2A PROFIsafe:								
x + 0	-	-	-	-	Channel 3	Channel 2	Channel 1	Channel 0
x = Module start address								



Warning

You must only access the addresses occupied by useful data. The other address ranges occupied by the F-modules are assigned for functions including safety-related communication between the F-modules and F-CPU in accordance with PROFIsafe.

In 1oo2 evaluation of sensors, only the less significant channel of the channels that are grouped as a result of the 1oo2 sensor evaluation can be accessed in the safety program.

Additional Information

Detailed information on F-I/O access can be found in the *S7 Distributed Safety, Configuring and Programming* manual or the *S7 F/FH Automation Systems* manual.

3.2 Assignment of the PROFIsafe address

PROFIsafe Address

Each fail-safe module has its own PROFIsafe address in addition to the PROFIBUS address. Before installing fail-safe modules, you must set the PROFIsafe address on each F-module.

PROFIsafe Address Assignment

The PROFIsafe addresses (F_source_address, F_destination_address) are automatically assigned when the fail-safe modules are configured in *STEP 7*.

You can view the F_destination_address in binary format in *HW Config* in the Object properties of the fail-safe modules in the "DIP switch setting" parameter. You read the PROFIsafe address from the parameter assignment dialog box and set it on the fail-safe module using an address switch.

You can change the configured F_destination_address in *HW Config*. To prevent addressing errors, however, we recommend using the automatically assigned F_destination_address.

Address Switch for Setting PROFIsafe Addresses

An address switch (10-pin DIP switch) is located on the left-hand side of every fail-safe module. With this address switch, you enter the PROFIsafe address (F_destination_address) of the F-module.

Note

Fail-safe modules in ET 200S can only be used in safety mode.

Setting the Address Switch

Before installing the F-module, ensure that the address switch is set correctly.

PROFIsafe addresses 1 through 1022 are permitted. In the following figure, you can see an example of the switch setting for addressing.



Figure 3-1 Example for Setting the Address Switch (DIP Switch)

Rules for Address Assignment



Warning

Observe the following rules when assigning the address:

- Make sure that the address switch setting on the module matches the PROFIsafe address in *STEP 7 HW Config*.
- The switch setting on the address switch of the F-I/O, in other words, its PROFIsafe destination address must be unique within the network* and station** (throughout the system). A maximum of 1,022 PROFIsafe destination addresses can be assigned in one system. That is, a maximum of 1,022 F-modules can be addressed using PROFIsafe.

Exception: In different I-slaves, F-I/O can have the same PROFIsafe target addresses since they are only addresses within the station, in other words by the F-CPU in the I-slave.

- The following restriction applies only to ET 200S F-submodules whose default PROFIsafe addresses **cannot** be modified in *HW Config*.

If you use ET 200S F-modules whose PROFIsafe addresses cannot be modified in *HW Config* in a PROFIBUS network, you can only operate **one** DP master/I/O controller with F-CPU in this network; otherwise, the system-wide uniqueness of the PROFIsafe addresses cannot be guaranteed.

*: A network consists of one or more subnets. "Network-wide" means across subnet boundaries.

**:"Station-wide" means a station in *HW Config* (for example an S7-300 station or an I-slave)

3.3 Installing

Installing Fail-Safe Modules

Fail-safe power modules, electronic modules, and terminal modules are part of the ET 200S range of modules. They are installed using the same procedure as for all standard modules in an ET 200S.

For more information about module installation, consult the *ET 200S Distributed I/O System* manual.

Mounting Dimensions

Note that fail-safe modules are 30 mm wide (twice as wide as standard ET 200S modules). Otherwise, information provided in the *ET 200S Distributed I/O System* manual is applicable.

Wiring and Fitting Modules

4.1 Introduction



Warning

In order to prevent hazardous threats to persons or the environment, you must not under any circumstances override safety functions or implement measures that cause safety functions to be bypassed or that result in the bypassing of safety functions. The manufacturer is not liable for the consequences of such manipulations or for damages that result from failure to heed this warning.

Overview

This chapter presents special features involved in wiring and fitting fail-safe modules. Information on this subject that applies to both ET 200S with fail-safe modules and ET 200S with standard modules can be found in the *ET 200S Distributed I/O System* manual.

4.2 Safe Functional Extra Low Voltage for Fail-Safe Modules

Safe functional extra low voltage



Warning

Fail-safe modules must be operated with safe functional extra low voltage. This means that these modules, even in the event of a fault, can only have a maximum voltage of U_m . The following applies for all fail-safe modules:

$$U_m < 60.0 \text{ V}$$

You can find additional information about safe functional extra low voltage, for example, in the data sheets of the applicable power supplies.

All components of the system that are capable of supplying electrical energy in any form must satisfy this requirement.

Each additional circuit (24 VDC) implemented must have a safe functional extra low voltage. Refer to the relevant data specification sheets or contact the manufacturer for information.

Note, too, that sensors and actuators having an external power supply can be connected to F-modules. Here, pay attention to the supply voltage from safe functional extra-low voltage. The process signal of a 24 VDC digital module must not exceed a fault voltage of U_m in the event of a fault.



Warning

All power sources, for example internal 24 V DC load voltage power supplies, external 24 V DC load voltage power supplies, 5 V DC bus voltage must be electrically connected externally. This prevents voltage additions in the individual voltage sources that would cause the fault voltage U_m to be exceeded even if there are voltage differences.

Ensure that there is sufficient line cross section for the electrical connection, in accordance with the ET 200S configuration guidelines (see *ET 200S Distributed I/O System* manual).

Power Supply Requirements in Compliance with NAMUR Recommendations

Note

You must use only power packs or power supplies (230 VAC --> 24 VDC) with a power failure ride-through of at least **20 ms** to comply with NAMUR recommendation NE 21, IEC 61131-2, and EN 298. The latest up-to-date information on power supply components are available on the Internet at:

<https://mall.ad.siemens.com>

These requirements are also applicable for network devices and power supplies that are not manufactured to ET 200S or S7-300/-400 configuration standards.

4.3 Wiring fail-safe modules

Same Wiring Procedure as for ET 200S

Fail-safe power modules, electronic modules, and terminal modules are part of the ET 200S range of modules. They are wired using the same procedure as for all standard modules in an ET 200S.

Refer to the *ET 200S Distributed I/O System* manual for detailed information on wiring and configuration of modules and the IM151.



Warning

When assigning signals of the F-DI module, remember that signals should only be routed within a cable or a nonmetallic sheathed cable if:

- A short circuit in the signals does not conceal a serious safety risk
 - Signals are supplied by different sensor supplies of this F-DI module
-

Mounting Rails

Only **35 x 15 mm** zinc-plated mounting rails in accordance with EN 50022 can be used for installing ET 200S with fail-safe modules. Mounting rails with the following order numbers, for example, comply with this requirement:

- 6ES5 710-8MA11
- 6ES5 710-8MA21
- 6ES5 710-8MA31
- 6ES5 710-8MA41

Assignment of Terminal Modules

The terminal assignment of the terminal modules depends on the installed power or electronic module.

See also

Wiring of the PM-E F pm DC24V PROFIsafe (Page 7-11)

Wiring of the PM-E F pp DC24V PROFIsafe (Page 7-29)

Wiring of the PM-D F DC24V PROFIsafe (Page 7-41)

Wiring of the EM 4/8 F-DI 24 VDC PROFIsafe (Page 7-50)

Wiring diagram of the EM 4 F-DO DC24V/2A PROFIsafe (Page 7-84)

4.4 Insertion and removal of fail-safe modules

Inserting and Removing Electronic Modules

In ET 200S, the same procedure is used to insert and remove both fail-safe modules and standard modules on terminal modules (see ET 200S Distributed I/O System manual).

Inserting and Removing Electronic Modules during Operation

F-modules can be inserted and removed during operation in exactly the same way as standard modules in ET 200S.

Note

Note that replacing fail-safe modules in ET 200S during operation causes a communication error on the F-CPU.

You must acknowledge the communication error in your safety program (for the response of the F-system after communication errors, output of a fail-safe value and user acknowledgment, refer to the *S7 Distributed Safety, Configuration and Programming or Programmable Controllers S7 F/FH* manual). *S7 F/FH Automation Systems*).

If the communication error is not acknowledged, the useful data of the F-DO modules remain passivated (outputs at "0").

Requirements for Insertion and Removal during Operation

The following table lists the F-modules that can be inserted and removed during operation, and the conditions under which this is possible:

Table 4-1 Conditions for Inserting and Removing Fail-Safe Modules During Operation

Module	Insertion and Removal	Conditions
Interface module	No	–
Fail-safe power module (PM E-F pm)	Yes	Load voltage must be switched off
Fail-safe power module (PM E-F pp)	Yes	
Fail-safe power module (PM D-F)	Yes	
Fail-safe electronic module (F-DI)	Yes	–
Fail-safe electronic module (F-DO)	Yes	–

Remember to Set the PROFIsafe Address

When exchanging F-modules, ensure that the address switch (DIP switch) settings of the modules match.

See also

Assignment of the PROFIsafe address (Page 3-3)

4.5 Requirements for Sensors and Actuators

General Requirements for Sensors and Actuators

Note the following important information for safety-related use of sensors and actuators:



Warning

The use of sensors and actuators is outside of our sphere of influence. We have equipped our electronics with such safety engineering features as to leave 85% of the maximum permissible probability of hazardous faults for sensors and actuators up to you (This corresponds to the recommended load division in safety engineering between sensing devices, actuating devices, and electronic switching for input, processing, and output).

Note, therefore, that instrumentation with sensors and actuators bears a considerable **safety responsibility**. Consider, too, that sensors and actuators do not generally withstand proof-test intervals of 10 years (the interval for an external function test according to IEC 61508) without considerable loss of safety.

The probability of hazardous faults and the rate of occurrence of hazardous faults of a safety function must comply with an upper limit determined by a safety integrity level (SIL). You will find a listing of values achieved by F-modules under "Fail-Safe Performance Characteristics" in the technical specifications for F-modules in Chapter 9.

To achieve SIL3 (AK6/Category 4), suitably qualified sensors are necessary.

Requirements for the Duration of Sensor Signals



Warning

Observe the following requirements for sensor signals:

- In order to guarantee accurate detection of the sensor signal by the F-DI module, you must ensure that the sensor signals have a particular minimum duration.
- In order for pulses to be detected with certainty, the time between two signal changes (pulse duration) must be greater than the PROFIsafe monitoring time.

Reliable acquisition by the F-DI module

The following table lists the minimum duration of the sensor signals for the F-DI module. This depends on the parameter settings for the short-circuit test and the input delay in *STEP 7*.

Table 4-2 Minimum Duration of the Sensor Signals to Allow Correct Acquisition by the F-DI Module

Short-Circuit Test Parameter	Assigned Input Delay		
	0.5 ms	3 ms	15 ms
Deactivated	7 ms	9 ms	23 ms
Activated	7 ms	12 ms	37 ms

Reliable acquisition by the safety program on the F-CPU

You will find information on the times necessary for correct acquisition of the sensor signals in the safety program in "*Fail-Safe Modules*" in the system description *Safety Engineering in SIMATIC S7*.

Additional Requirements for Actuators

Fail-safe modules test the outputs in regular intervals. To do so, the F-module briefly switches off activated outputs. The test pulses have the following duration:

- Dark period < 1 ms

Rapid response actuators can drop out briefly during the test. If your process does not tolerate this, you must use actuators with a sufficient lag (> 1 ms).



Warning

If the actuators are operated at voltages higher than 24 VDC (for example, 230 VDC) or if the actuators clear higher voltages, safe isolation must be ensured between the outputs of a fail-safe output module and the components carrying a higher voltage (in accordance with EN 50178).

This is generally the case for relays and contactors. Particular attention must be paid to this aspect for semiconductor switching devices.

See also

Assignment of the PROFIsafe address (Page 3-3)

Technical Specifications for PM-E F pm 24 VDC PROFIsafe (Page 7-20)

Technical Specifications for the PM-E F pp 24 VDC PROFIsafe (Page 7-34)

Technical Specifications of the PM-D F DC24V PROFIsafe (Page 7-45)

Technical Specifications for the EM 4/8 F-DI 24 VDC PROFIsafe (Page 7-77)

Technical Specifications of the EM 4 F-DO DC24V/2A PROFIsafe (Page 7-93)

Diagnostics

5.1 Reactions to Faults

Safe State (Safety Concept)

The basic principle behind the safety concept is the existence of a safe state for all process variables. For digital F-modules, the safe state is, for example, the value "0". This applies to both sensors and actuators.

Reactions to Faults and Startup of F-System

The safety function requires that fail-safe values (safe state) be applied to a fail-safe module instead of process data (**passivation of the fail-safe module**) in the following situations:

- When the F-system is started up
- In the case of errors during safety-related communication between the F-CPU and F-module via the PROFIsafe safety protocol (communication fault).
- If F-I/O or channel faults occur (e.g., wire break, short circuit, discrepancy error)

Detected faults are entered in the diagnostic buffer of the F-CPU and the safety program in the F-CPU is informed.

F-modules cannot save data as retentive data. When the system is powered down and then back up, any faults still existing are detected again during startup. However, you have the option of saving faults in your safety program.



Warning

For channels that you set to "deactivated" in *STEP 7*, there is no diagnostic reaction or error handling if a channel fault occurs, not even when this channel is affected indirectly by a channel group fault ("Channel activated/deactivated" parameter).

Fail-safe value Output for Fail-Safe Modules

With F-DI modules, if channels are passivated, the F-system provides fail-safe values for the safety program instead of the process values applied to the fail-safe inputs.

- For F-DI modules, this is always the fail-safe value 0.

With F-DO and PM-E F pm DC24V PROFIsafe modules, if channels are passivated, the F-system transfers fail-safe values (0) to the fail-safe outputs instead of the output values provided by the safety program. The output channels go to the zero current and zero voltage state. This also applies when the F-CPU goes into STOP mode. It is not necessary to assign parameters for fail-safe values.

Depending on which F-system is used and the type of fault that occurred (F-I/O, channel, or communication fault), fail-safe values are used either for the affected channel only or for all channels of the fail-safe module involved.

In S7 Distributed Safety F-systems up to V5.3, when a channel fault occurs the entire F-module is passivated. Starting with S7 Distributed Safety V5.4, F-modules as of the indicated order numbers can also be passivated on a channel-level basis.

Reintegration of a Fail-Safe Module

Switchover from fail-safe values to process values (reintegration of an F-module) occurs either automatically or only after user acknowledgement in the safety program. If channel faults occur, it may be necessary to remove and insert the F-module. For an exact list of the faults that require removal and insertion of the F-module see "PM-E F pm DC24V PROFIsafe Power Module" to "4 F-DO DC24V/2A PROFIsafe Digital Electronic Module" in the "Causes of Faults and Corrective Measures" table.

After reintegration, the following occurs:

- For a fail-safe DI module, the process values pending at the fail-safe inputs are provided for the safety program
- For a fail-safe DO module, the output values provided in the safety program are again transferred to the fail-safe outputs

Additional Information on Passivation and Reintegration

For more detailed information on passivation and reintegration of F-I/O, refer to the *S7 Distributed Safety, Configuring and Programming* manual or *S7 F/FH Automation Systems* manual.

F-DI Module Reaction to Communication Errors

The F-DI module responds differently to a communication error than to other faults.

If a communication fault occurs, the current process values remain set at the inputs of the F-DI module; there is no passivation of the channels. The current process values are sent to the F-CPU and are passivated in the F-CPU.

See also

- Properties of the PM-E F pm DC24V PROFIsafe Power Module (Page 7-2)
- Properties of the PM-E F pp DC24V PROFIsafe Power Module (Page 7-24)
- Properties of the PM-D F DC24V PROFIsafe Power Module (Page 7-37)
- Properties of the 4/8 F-DI 24 VDC PROFIsafe Digital Electronic Module (Page 7-47)
- Properties of the 4 F-DO DC24V/2A PROFIsafe digital electronic module (Page 7-80)

5.2 Fault Diagnostics

Purpose of diagnosis

Diagnostics are used to determine whether fail-safe module signal acquisition is taking place without errors. Diagnostic information is assigned either to one channel or to the entire F-module.

Diagnostic Functions Are Not Critical to Safety

Diagnostic functions (displays and messages) are not critical to safety and therefore are not designed to be safety-related functions. That is, they are not tested internally.

Diagnostic Options for Fail-Safe Modules in ET 200S

The following diagnostic options are available for fail-safe modules:

- LED display on the module front panel
- Diagnostic functions of F-modules (slave diagnostics in accordance with PROFIBUS standard IEC 61784-1:2002 Ed1 CP 3/1 or PROFINET IO standard IEC 61784-1:2002 Ed1 CP 3/3).

Diagnostic Functions That Cannot Be Activated by the User

Fail-safe electronic and power modules provide diagnostic functions that cannot be assigned as parameters. This means that diagnostics are always activated and are automatically made available by the F-module in *STEP 7* and passed on to the F-CPU in the event of a fault.

Diagnostic Functions That Can Be Assigned As Parameters

You can assign (activate) certain diagnostic functions as parameters in *STEP 7*:

- Wire-break detection for the F-DO module and the PM-E F pm
- Short-circuit monitoring for the F-DI module



Warning

Diagnostic functions should be activated or deactivated in accordance with the application.

Diagnostics by LED Display

Every fail-safe power and electronic module indicates faults by means of its SF LED (group fault LED). The SF-LED lights up as soon as a diagnostic function is triggered by the F-module. It is extinguished when all faults have been eliminated.

The power module also has a PWR LED, which displays the load voltage power supply of the voltage group.

The 4/8 F-DI 24 VDC PROFIsafe electronic module also has two fault LEDs (1VsF and 2VsF) that display faults for both internal sensor power supplies.

Slave Diagnostics

The slave diagnostics comply with IEC 61784-1:2002 ED1 CP 3/1 or CP 3/3. The fail-safe electronic and power modules support the slave diagnostics in exactly the same way as ET 200S standard modules.

You will find a description of the general configuration of slave diagnostics for ET 200S and the fail-safe modules in the *ET 200S Distributed I/O System* manual . A supplementary description of channel-related diagnostics for fail-safe modules is presented below.

Channel-specific diagnostics

As with the ET 200S, there are three bytes available for channel-related diagnostics starting at byte 35 for each F-module. A maximum of 9 channel-related diagnostic messages are possible per station. Channel-specific diagnostics for fail-safe modules are configured as follows:

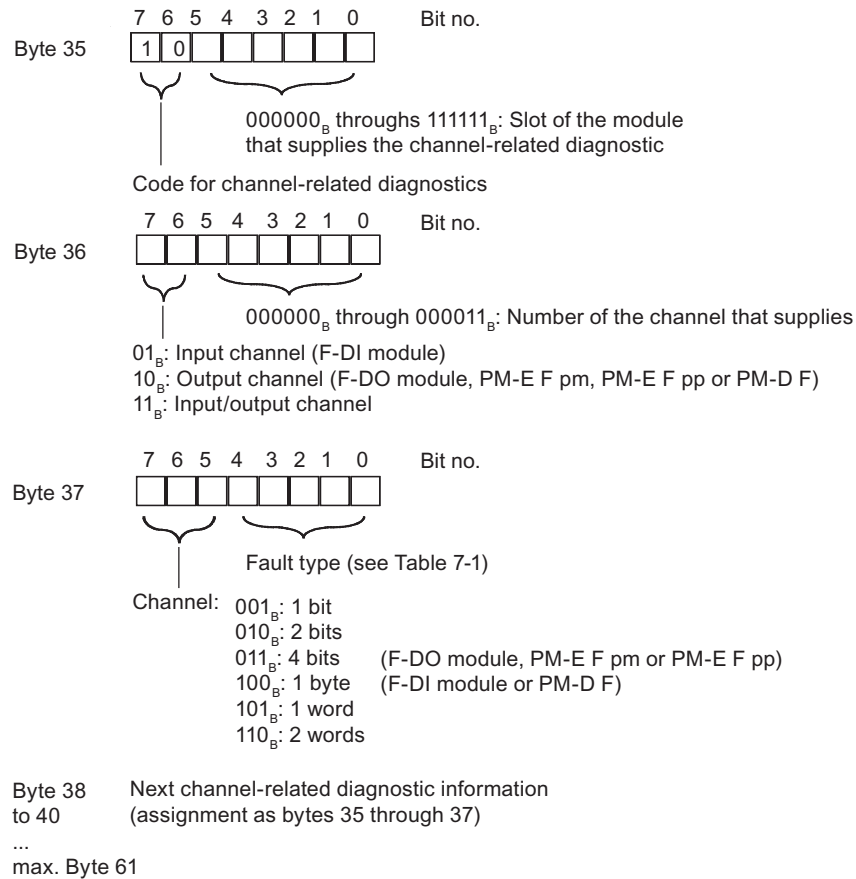

Figure 5-1 Figure-Configuration of Channel-Specific Diagnostics

Note

In byte 35, bit 0 to 5, the module slot is encoded. The following applies:
 displayed number +1 = module slot
 (0 = slot 1; 1 = slot 2, etc.)

Note

Channel-related diagnostics are always updated to the current diagnostic function in the diagnostic message frame. Subsequent, older diagnostic functions are not deleted.

Remedy: Evaluate the valid current length of the diagnostic message frame in *STEP 7* using the RET_VAL parameter of SFC13.

Possible Fault Types of Fail-Safe Modules

The following table lists the messages of the IM151-1 HIGH FEATURE. If you use the IM 151-7 F CPU, you will obtain detailed diagnostic information using *Hardware Diagnostics* in *STEP 7*.

Table 5-1 Channel-Specific Diagnostics: Fault Types of Fail-Safe Modules

F-Module	Fault Number	Diagnostic Function in <i>STEP 7</i> (Fault Type)	Special Meaning for F-Modules
All F-modules	1H	Short circuit	Short circuit
	5H	Overtemperature	Overtemperature
	9H	Fault	Internal fault
	10H	Parameter assignment error	Parameter assignment error
	11H	Sensor voltage or load voltage is missing	Missing external auxiliary supply
	13H	Communication error	Communication error
PM-E F pm DC24V	4H	Overload	Overload
	6H	Line break	Wire break
	19H	Safety-related shutdown	Switching frequency exceeded
PM-E F pp DC24V	19H	Safety-related shutdown	Switching frequency exceeded
4/8 F-DI DC24V	19H	Safety-related shutdown	Discrepancy error
4 F-DO DC24V/2A	4H	Overload	Overload
	6H	Line break	Wire break
	19H	Safety-related shutdown	Switching frequency exceeded

Reaction of F-Modules to Module Failure

The following events occur following a serious internal fault in the F-module causing F-module failure:

- The connection to the backplane bus is interrupted, and the fail-safe inputs and outputs are passivated.
- Diagnostics are not transmitted from the F-module, and the "Module Fault" standard diagnostics message is issued.
- The SF LED of the corresponding module illuminates.

Specific Information about Diagnostic Functions

All module-specific diagnostic functions, possible causes and their corrective measures are described in "PM-E F pm DC24V PROFIsafe Power Module "to "4 F-DO DC24V/2A PROFIsafe Digital Electronic Module".

The status and diagnostic functions indicated by LEDs on the front panel of each F-module are also presented in these sections.

Reading out Diagnostic Functions

You can display the cause of a fault in the module diagnostics of *STEP 7* (see *STEP 7 Online Help*).

You can read out diagnostic functions (slave diagnostics) by means of SFC 13 in the standard user program (see *System and Standard Functions* reference manual).

See also

Diagnostic Functions of PM-D F DC24V PROFIsafe (Page 7-42)

Diagnostic functions of the PM-E F pm DC24V PROFIsafe (Page 7-17)

Diagnostic functions of the PM-E F pp DC24V PROFIsafe (Page 7-32)

Diagnostic Functions of the EM 4/8 F-DI 24 VDC PROFIsafe (Page 7-74)

Diagnostic Functions of the EM 4 F-DO 24 VDC/2 A PROFIsafe (Page 7-90)

General technical specifications

6.1 Introduction

Overview

This chapter presents the following information about fail-safe modules:

- Information about the most important standards and approvals
- Information about the general technical specifications

General technical specifications

The general Technical Specifications include the standards and test values that the fail-safe modules comply with and meet when installed in an ET 200S and the test criteria under which the fail-safe modules were tested, and also the requirements of the fail-safe modules for transport, storage and environmental conditions.

6.2 Standards and Approvals

CE approval



The ET 200S fail-safe modules meet the requirements and protection targets of the following EC Directives and comply with the harmonized European standards that have been issued for PLCs in the official gazettes of the European Community:

- 73/23/EEC "Electrical Equipment Designed for Use within Certain Voltage Limits" (low voltage directive)
- 89/336/EEG "Electromagnetic Compatibility" (EMC Guideline)
- 94/9/EC "Equipment and Protective Systems Intended for Use in Potentially Explosive Atmospheres" (Explosion Protection Guideline)

The EC declarations of conformity are kept available for the relevant authorities at:

Siemens Aktiengesellschaft
Bereich Automatisierungstechnik
A&D AS RD ST
Postfach 1963
D-92209 Amberg

UL approval



Underwriters Laboratories Inc., in accordance with

- UL 508 (Industrial Control Equipment)

CSA Approval



Canadian Standard Association (CSA) in accordance with

- C22.2 No. 142 (Process Control Equipment)

or



Underwriters Laboratories Inc., in accordance with

- UL 508 (Industrial Control Equipment)
- CSA C22.2 No. 142 (Process Control Equipment)

or



HAZ. LOC.

Underwriters Laboratories Inc., in accordance with

- UL 508 (Industrial Control Equipment)
- CSA C22.2 No. 142 (Process Control Equipment)
- UL 1604 (Hazardous Location)
- CSA-213 (Hazardous Location)

APPROVED for use in
Class I, Division 2, Group A, B, C, D Tx;
Class I, Zone 2, Group IIC Tx

Note

The nameplate of the specific module indicates the currently valid approvals.

FM approval



Factory Mutual Research (FM) to

- Approval Standard Class Number 3611, 3600, 3810

APPROVED for use in

Class I, Division 2, Group A, B, C, D Tx;

Class I, Zone 2, Group IIC Tx



In accordance with EN 50021 (Electrical Apparatus for Potentially Explosive Atmospheres; Type of Protection "n")

II 3 G EEx nA II T4..T5



Warning

There is a risk of personal injury or property damage.

In areas exposed to explosion hazard, personal injury or property damage can occur if plug-in connections are disconnected during operation.

Before disconnecting plug-in connections in areas exposed to explosion hazard, always deenergize the distributed I/O.

Marking for Australia



The fail-safe modules of the ET 200S satisfy the requirements of AS/NZS 2064 (Class A).

IEC 61131

The fail-safe modules of the ET 200S satisfy the requirements and criteria of IEC 61131-2 (Programmable Controllers - Part 2: Equipment Requirements and Tests).

PROFIBUS standard

The ET 200S distributed I/O system is based on the IEC 61784-1:2002 Ed1 CP 3/1 standard.

Shipbuilding approval

Submitted to the following classification bodies
(exception: PM-D F DC24V PROFIsafe for GL (German Lloyd) only:

ABS (American Bureau of Shipping)

BV (Bureau Veritas)

DNV (Det Norske Veritas)

GL (Germanischer Lloyd)

LRS (Lloyds Register of Shipping)

Class NK (Nippon Kaiji Kyokai)

Use in Industry

SIMATIC products are designed for use in industrial environments.

Field of Application	Requirement Relating to	
	Emitted Interference	Immunity to Interference
Industry	EN 50081-2 : 1993 (revoked)	EN 50082-2 : 1995

Use in Residential Areas

If you use the ET 200S in residential areas, you must ensure limit class B (EN 55011) for emission of radio interference.

Suitable measures for achieving limit class B for emission of radio interference are:

- Installing the ET 200S in grounded switching cubicles/switch boxes
- Use of filters in power supply lines

TÜV Certificate and Standards

Fail-safe modules are certified for the following standards. Refer to the report accompanying the TÜV certificate for the current version/edition of the standard.

Standards/Directives Functional Safety	Standards/Directives Machine Safety	Additional Standards/Guidelines
DIN V 19250	98/37/EC	DIN VDE 0110-1
DIN V VDE 0801	EN 60204-1	DIN VDE 0160
DIN V VDE 0801/A1	EN/ISO 954-1/13849-1	93/68/EEC
IEC 61508-1 to 7	prEN 954-2	92/31/EEC and 93/68/EEC
prEN 50159-1 and 2	Standards/Directives Fuel Engineering	DIN EN 55011 (revoked)
Standards/Directives Process Engineering	DIN VDE 0116, Clause	EN 50081-2 (revoked)
DIN V 19251	prEN 50156-1	EN 61000-6-2
VDI/VDE 2180-1 to 5	EN 230, Clause	DIN EN 61131-2
NE 31	EN 298, Clauses. 7.3, 8, 9, and 10	
ISA S 84.01	DIN V ENV 1954 (revoked)	

Requesting TÜV Certificate

You can request copies of the TÜV certificate and the accompanying report at the following address:

Siemens Aktiengesellschaft
Bereich Automatisierungstechnik
A&D AS RD ST
Postfach 1963
D-92209 Amberg

6.3 Electromagnetic Compatibility

Introduction

This chapter presents information about immunity to interference of fail-safe modules and about EMC conformity.

Definition of EMC

Electromagnetic compatibility is the ability of an electrical device to function in its electromagnetic environment in a satisfactory manner without affecting this environment.

Fail-safe modules also comply with the requirements of the EMC law for the European internal market. As a requirement, the ET 200S distributed I/O system must comply with the specifications and guidelines for electrical configuration.

Pulse-shaped interference

The following table presents the electromagnetic compatibility of fail-safe modules with regard to pulse-shaped interference.

Pulse-Shaped Interference	Tested With	Degree of Severity
Electrostatic discharge in accordance with IEC 61000-4-2 (DIN VDE 0843 Part 2)	8 kV	3 (air discharge)
	6 kV (cabinet installation mandatory)	3 (contact discharge)
	4 kV (no cabinet installation)	
Burst pulse (rapid transient interference) in accordance with IEC 61000-4-4 (DIN VDE 0843 Part 4)	2 kV (supply line)	3
	2 kV (signal line)	4
Surge in accordance with IEC 61000-4-5 (DIN VDE 0839 Part 10) Degrees of severity 2 and 3 require an external protective circuit (see paragraph below)		
Asymmetrical connection	1 kV (supply line)	2
	1 kV (signal lead/data lead)	
Symmetrical connection	2 kV (supply line)	3
	0.5 kV (supply line)	2
	0.5 kV (signal lead/data lead)	
	1 kV (supply line)	3
	1 kV (signal lead/data lead)	

Protecting the ET 200S with Fail-Safe Modules from Overvoltage

If your equipment makes protection from overvoltage necessary, we recommend that you use an external protective circuit (surge filter) between the low voltage power supply and the low voltage input of the terminal modules to ensure surge immunity for the ET 200S with fail-safe modules.

Note

Lightning protection measures always require a case-by-case examination of the entire system. Nearly complete protection from overvoltages, however, can only be achieved if the entire building surroundings have been designed for overvoltage protection. In particular, this involves structural measures in the building design phase.

Therefore, for detailed information regarding overvoltage protection, we recommend that you contact your Siemens representative or a company specializing in lightning protection.

The following figure illustrates an example of a configuration with F-modules, standard modules, and the power modules PM-E DC24..48V/AC24..230V and PM-E F pm DC24V PROFIsafe. Voltage is supplied over four power supplies.

You can also use fewer power supplies. However, you must ensure that the total current of the modules fed by one power supply does not exceed the permissible limits.

You can also use PM-E DC24V power modules; the protective circuit corresponds to that of the PM-E DC24..48V/AC24..230V + miniature circuit breaker (as for PM-E F pm DC24V PROFIsafe).

For additional information about surge protection for standard modules, see the *ET 200S Distributed I/O System* manual.

Sinusoidal interference

HF radiation of the device in accordance with IEC 61000-4-3:

- Electromagnetic HF field, amplitude modulated:
from 80 through 2000 MHz; 10 V/m; 80 % AM (1 kHz)
- Electromagnetic HF field, pulse-modulated:
900 ± 5 MHz; 10 V/m; 50 % ESD; 200 Hz repetition rate
- GSM/ISM field interference, different frequencies (EN 298: 1998):

System	Frequency	Test Level	Modulation
GSM	890-915 MHz	20 V/m	Pulse modulation 200Hz
GSM	1710-1785 MHz	20 V/m	Pulse modulation 200Hz
GSM	1890 MHz	20 V/m	Pulse modulation 200Hz
ISM	433.05-434.79 MHz	20 V/m	AM, 80 %, 1 kHz
ISM	83,996-84,004 MHz	20 V/m	AM, 80 %, 1 kHz
ISM	167,992-168,008 MHz	20 V/m	AM, 80 %, 1 kHz
ISM	886.000-906.000 MHz	20 V/m	AM, 80 %, 1 kHz

- HF coupling with signal lines and data lines, etc. complying with IEC 61000-4-6, high frequency, asymmetric, amplitude-modulated:
from 0.15 through 80 MHz; 10 V R. M. S value, unmodulated; 80 % AM (1 kHz); 150 Ω source impedance
- GSM/ISM field interference, different frequencies (EN 298: 1998):

System	Frequency	Test Level	Modulation
ISM	6,765-6,795 MHz	20 V	AM, 80 %, 1 kHz
ISM	13,553-13,567 MHz	20 V	AM, 80 %, 1 kHz
ISM	26,957-27,283 MHz	20 V	AM, 80 %, 1 kHz
ISM	40.66-40.70 MHz	20 V	AM, 80 %, 1 kHz
ISM	3.370-3.410 MHz	20 V	AM, 80 %, 1 kHz
ISM	13.533-13.533 MHz	20 V	AM, 80 %, 1 kHz
ISM	13.567-13.587 MHz	20 V	AM, 80 %, 1 kHz

Radio Interference Emission

Interference transmission of electromagnetic fields in accordance with EN 55011: limit class A, group 1 (measured at a distance of 10 m).

Frequency	Emitted Interference
Between 30 MHz and 230 MHz	< 40 dB (μ V/m)Q
Between 230 MHz and 1000 MHz	< 47 dB (μ V/m)Q

Emitted interference by means of network-AC power supply in accordance with EN 55011: limit value class A, group 1.

Frequency	Emitted Interference
Between 0.15 MHz and 0.5 MHz	< 79 dB (μ V)Q, < 66 dB (μ V)M
Between 0.5 MHz and 5 MHz	< 73 dB (μ V)Q, < 60 dB (μ V)M
Between 5 MHz and 30 MHz	< 73 dB (μ V)Q, < 60 dB (μ V)M

6.4 Transport and storage conditions

Requirements for Fail-Safe Modules

Fail-safe modules exceed the requirements for transport and storage in accordance with IEC 61131, Part 2. The following details apply for fail-safe modules that are transported or stored in the original packaging.

Type of Condition	Permissible range
Free fall	≤ 1 m
Temperature	from -40 °C to $+70$ °C
Temperature change	20 K/h
Air pressure	1080 hPa to 660 hPa (corresponds to an altitude of -1000 m to 3500 m)
Relative humidity	5% to 95%, without condensation

6.5 Mechanical and Climatic Environmental Conditions

Conditions of use

Fail-safe modules are intended for use as permanently installed modules protected from the elements. The conditions of use exceed the requirements of IEC 61131-2.

Fail-safe modules comply with the conditions of use of Class 3C3 in accordance with DIN EN 60721 3-3 (use in locations with heavy traffic and in the immediate vicinity of industrial systems with chemical emissions).

Restrictions

Fail-safe modules **cannot** be implemented in the following locations without additional measures being taken:

- Locations with a high level of ionizing radiation
- Locations with severe operating conditions; for example, due to
 - Dust
 - Corrosive vapors or gases
- Systems that require special monitoring, such as:
 - Electrical systems in particularly hazardous areas

An additional measure for implementing fail-safe modules can be, for example, installing the ET 200S in cabinets.

Mechanical Environmental Conditions

The mechanical environmental conditions for fail-safe modules are presented in the following table as sinusoidal oscillations.

Frequency Range (Hz)	Continuous	Intermittent
$10 \leq f \leq 58$	0.15 mm amplitude	0.35 mm amplitude
$58 \leq f \leq 150$	2 g constant acceleration	5 g constant acceleration

Reduction of Vibration

If fail-safe modules are subjected to sizable shock pulses or oscillation, you must take appropriate measures to reduce acceleration and amplitude.

We recommend that you mount the ET 200S on cushioning material (for example, on a rubber-metal vibration damper).

Testing for Mechanical Environmental Conditions

The following table provides information about the type and scope of testing for mechanical environmental conditions.

Condition	Test Standard	Comments
Vibration	Vibration test in accordance with IEC 60068-2-6 (sine)	Type of vibration: frequency cycles with a speed of change of 1 octave/minute. 10 Hz ≤ f ≤ 58 Hz, constant amplitude 0.35 mm 58 Hz ≤ f ≤ 150 Hz, constant acceleration 5 g Duration of vibration: 10 frequency sweeps per axis in each of three perpendicular axes
Shock	Shock, tested to IEC 60068-2-27	Shock method: half sine Strength of shock: 15 g peak value, 11 ms duration Direction of shock: 3 shocks each in +/- direction in each of three perpendicular axes
Continuous shock	Shock, tested to IEC 60068-29	Shock method: half sine Strength of shock: 25 g peak value, 6 ms duration Direction of shock: 1000 shocks each in +/- direction in each of three perpendicular axes

Climatic Environmental Conditions

ET 200S with fail-safe modules can be used under the following climatic environmental conditions:

Environment-Related requirements	Range of Application	Comments
Temperature	0 to 60 °C	For horizontal installation
	0 to 40 °C	For vertical installation
Temperature change	10 K/h	
Relative humidity	15 to 95 %	No condensation; corresponds to relative humidity (RH) stress level 2 in accordance with IEC 61131-2
Air pressure	1080 hPa to 795 hPa	Corresponds to an altitude of -1000 m to 2000 m
Contaminant concentration	SO ₂ : < 0.5 ppm; relative humidity < 60%, no condensation H ₂ S: < 0.1 ppm; relative humidity < 60%, no condensation	Test: 10 ppm; 4 days 1 ppm; 4 days

6.6 Specifications for Nominal Line Voltages, Isolation Tests, Protection Class, and Type of Protection

Nominal Line Voltages for Operation

The fail-safe modules operate with the nominal line voltage 24 VDC. The tolerance range is 2.0 VDC to 28.8 VDC.

Test voltages

Isolation stability is proven in routine testing with the following test voltages in accordance with IEC 61131 Part 2:

Circuits with Nominal Line Voltage U_e against Other Circuits and against the Ground	Test Voltage
$0\text{ V} < U_e \leq 50\text{ V}$	500 VDC

Protection class

Protection class I in accordance with IEC 60536 (VDE 0106, Part 1), i.e., ground terminal required on DIN rail!

Type of Protection

Type of protection IP20 according to EN 60529 for all fail-safe modules, in other words:

- Protection from contact with standard probes.
- Protection from foreign bodies larger than 12.5 mm in diameter is applicable.
- No special protection against water.

Fail-Safe Modules

7.1 Introduction

Overview

Fail-safe power modules and fail-safe digital modules are available for connecting digital sensors or encoders and actuators or loads to ET 200S. This chapter provides the following information for each fail-safe module:

- Properties and special features
- Front view, terminal assignment for terminal modules, and block diagram
- Wiring diagram and programmable parameters
- Diagnostic functions, including corrective measures
- Technical specifications



Warning

The safety characteristics in the Technical Specifications apply for a proof-test interval of 10 years and a repair time of 100 hours.

Description of Usable Standard Power Modules and Terminal Modules

The applicable standard power modules and terminal modules are described in the *ET 200S Distributed I/O System* manual.

7.2 PM-E F pm DC24V PROFIsafe Power Module

7.2.1 Properties of the PM-E F pm DC24V PROFIsafe Power Module

Order Number

6ES7 138-4CF02-0AB0

Properties

The PM-E F pm DC24V PROFIsafe power module has the following properties:

- Two relays for switching voltage buses P1 and P2, 10 A output current
- 2 fail-safe digital outputs, P/M-switching, output current 2 A
- 24 VDC rated load voltage
- Suitable for solenoid valves, DC contactors, and indicator lights
- Group fault display (SF; red LED)
- Status display for each output (green LED)
- Status display for load current power supply (PWR; green LED)
- Assignable diagnostics
- For achievable safety classes (safety integrity level), see following table

Table 7-1 Overview of Achievable Safety Classes (Safety Integrity Levels) with PM-E F pm DC24V PROFIsafe

PM-E F pm DC24V PROFIsafe			Maximum Safety Level That Can Be Achieved
Relay outputs P1 and P2	Without standard DO modules	Signal switches daily or more often	AK6/ SIL3/Category 4
		Signal switches less than once a day	AK4/ SIL2/ Category 3
	with standard DO modules		AK4/ SIL2/ Category 3
DO 0 and DO 1 electronic outputs	without standard DO modules on P1 and P2		AK6/ SIL3/Category 4
	with standard DO modules on P1 and P2		AK4/ SIL2/ Category 3

Switching of Voltage Buses P1 and P2

The power module can be used for fail-safe connection of voltage buses P1 and P2 by means of relay contacts in accordance with AK4/SIL2/Category 3.

Two fail-safe digital outputs

In addition to the P1 and P2 voltage buses the power module has two fail-safe digital outputs, DO 0 and DO 1. AK6/SIL3/Category 4 can be achieved with these outputs if standard DO modules are not connected to P1 and P2.

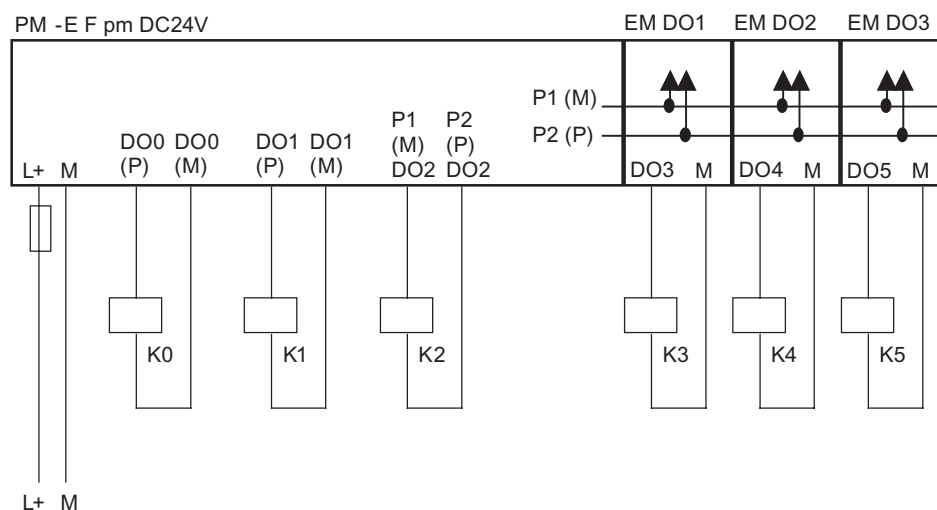

Figure 7-1 Wiring diagram of the PM-E F pm DC24V PROFIsafe

Conditions for Achieving Safety Class

The conditions for achieving the respective safety classes are summarized in the following table.

Table 7-2 PM-E F pm DC24V PROFIsafe: Conditions for AK/SIL/Category

Condition	Achievable AK/SIL/Category
ET 200S standard modules supplied by means of P1 and P2	AK4/SIL2/Category 3 on P1 and P2 and at DO 0 and DO 1
DO 0 and DO 1 used, modules not supplied by means of P1 and P2	AK6/SIL3/Category 4 on DO 0 and DO 1

Power Module Supplies for Standard ET 200S Modules



Warning

Always connect the 24 VDC supply for the standard ET 200S modules on the PM-E F pm DC24V PROFIsafe. Otherwise, the outputs of DO modules may exhibit safety critical behavior.



Warning

When supplying standard DO modules, always use the terminal modules to supply the sensors or actuators (actuator feedback on the DO module). Otherwise, the power module signals a short circuit and the load voltage of this voltage group is interrupted.

Safety-Related Shutdown of Standard DO Modules



Warning

The following ET 200S standard modules are approved for safety-related shutdown in accordance with SIL2:

- 2DO DC24V/0.5A (order number 6ES7 132-4BB01-0AA0 or higher)
 - 2DO DC24V/2A (order number 6ES7 132-4BB31-0AA0 or higher)
 - 2DO DC24V/0.5A HIGH FEATURE (order number 6ES7 132-4BB01-0AB0 or higher)
 - 2DO DC24V/2A HIGH FEATURE (order number 6ES7 132-4BB31-0AB0 or higher)
 - 4DO DC24V/0.5A (order number 6ES7 132-4BD00-0AA0 or higher)
 - 4DO DC24V/2A (order number 6ES7 132-4BD31-0AA0 or higher)
-

**Warning**

Safety-related activation of outputs of standard DO modules is not possible; rather, only safety-related **shutdown** is possible. You must therefore take the following effects into account:

In the worst case you must consider all possible faults of the standard DO modules and the programs controlling them for which the faults cannot be found directly. For example, the PM-E F pm DC24V PROFIsafe does not detect external short-circuits as per L+ at the standard DO module outputs. All faults of the standard DO modules influence the process via final controlling elements. The process must be made known to the F-CPU via sensors and a suitable safety program.

The safety program must react in a safety-related and logically suitable fashion to unwanted or potentially dangerous states in the process via the PM-E F pm DC24V PROFIsafe and fail-safe output modules.

If you want to avoid the problems described above completely, we recommend that you use P/M switching fail-safe electronic modules 4 F-DO DC24V/2A PROFIsafe with standard ET 200S power modules (see *"4 F-DO DC24V/2A PROFIsafe Digital Electronic Module"* and *Table "Assignment of Power Modules to Electronic Modules/Motor Starters and Safety Class"*) instead of standard DO modules.

Property of the safety-related shutdown of standard DO modules by the PM-E F pm DC24V PROFIsafe:

With this cost-effective solution, when a fault is discovered in the process or on the PM-E F pm DC24V PROFIsafe, there is a comprehensive and simultaneous shutdown of all outputs involved.

Property of individual shutdown of F-modules with fail-safe outputs:

If a fault is discovered, the extent of the shutdown is kept to a minimum. It is also possible to react to critical process states staggered over time or to perform safety-related shutdown of individual outputs. This solution is expensive compared with the safety-related shutdown by the PM-E F pm DC24V PROFIsafe.

Switching grounded loads

If the PM-E F pm DC24V PROFIsafe switches loads that have a connection between chassis and ground (for example to improve the EMC properties) **and** if chassis and ground are connected in the power supply being used, a "short circuit" will be detected.

From the perspective of the F-module, the M switch is bridged by the chassis-ground connection (refer to the following figure as an example of a PM-E F pm DC24V PROFIsafe).

Remedy:

- Use the PM-E F pp DC24V PROFIsafe
- The value of the resistance between chassis and ground at the load end must be greater than 100 kΩ

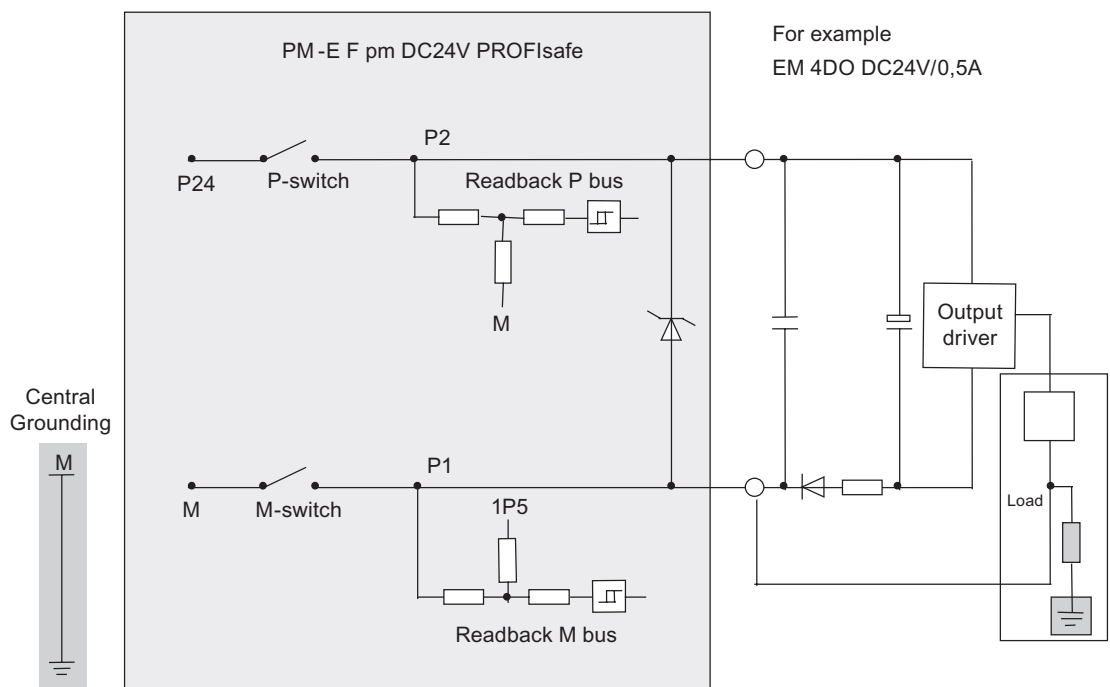

Figure 7-2 Connecting Grounded Loads (resistance exists between chassis and ground)

Capacitive Crosstalk of Digital Input/Output Signals

When fail-safe digital output signals and fail-safe digital input signals are routed through one cable, readback errors can occur on the PM E-F pm DC24V PROFIsafe power module or the F-DO modules. The module then signals a short-circuit.

Cause

During the sensor supply tests of the 4/8 F-DI DC24V PROFIsafe module, the steep switching edge of the output driver can cause crosstalk with other inactive output channels due to the coupling capacitance of the wire, for example on the PM E F pm DC24V PROFIsafe power module. In these channels, this can lead to a response in the readback circuit. A short is detected leading to a safety-related shutdown.

Remedy

- Use separate cables for F-DI modules and F-DO modules or standard DO modules driven by a PM-E F pm DC24V PROFIsafe
- Coupling relay or diodes in the outputs
- Turn off the sensor supply test if this is permitted by the required safety class (safety integrity level).

See also

Assigning Modules of an ET 200S (Page 2-4)

Properties of the 4 F-DO DC24V/2A PROFIsafe digital electronic module (Page 7-80)

7.2.2 Terminal assignment of the PM-E F pm DC24V PROFIsafe

Incoming Supply of the 24 VDC Supply for Electronic Modules with Process-Related Functions

Depending on whether the electronic and load current supplies are electrically isolated in the electronic modules with process-related functions (positioning, counting), you must adhere to the following wiring instructions:

- If electrically isolated, provide an external 24 VDC feed for the electronic module.
- If electrical isolation is not implemented, you must supply the electronic module from the voltage bus P1 of the PM-E F pm 24 VDC PROFIsafe power module.

AK4/SIL2/Category 3 is attainable in both cases.

Front View

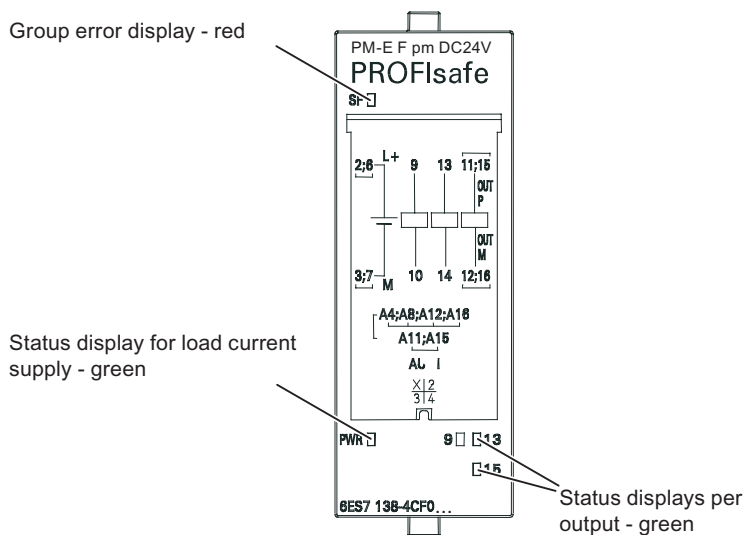

Figure 7-3 Front view of the PM-E F pm DC24V PROFIsafe



Warning

The SF LED and the status displays of the outputs must not be evaluated for safety-related activities.

Terminal assignment

The terminal assignment of the PM-E F pm DC 24 V PROFIsafe power module for the usable terminal modules TM-P30S44-A0 and TM-P30C44-A0 is shown in the following figure and table.

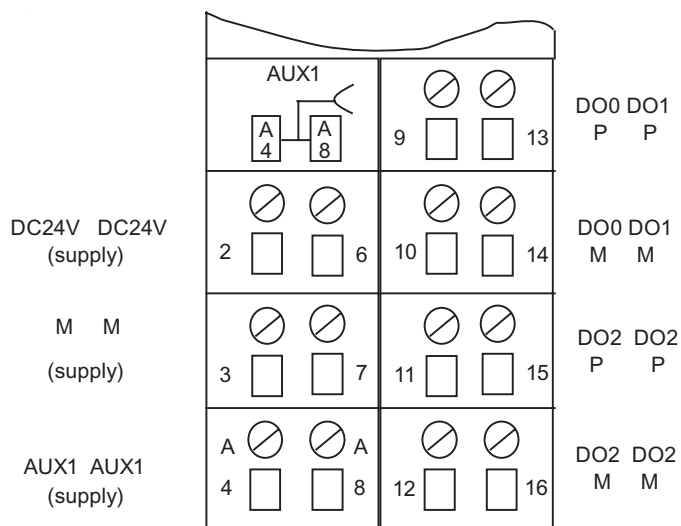

Figure 7-4 Terminal Assignment of the TM-P30S44-A0 or TM-P30C44-A0 for PM-E F pm DC 24V PROFIsafe

Table 7-3 Table-Terminal Assignment of the TM-P30S44-A0 or TM-P30C44-A0

Terminal		Designation
2	24 VDC	24 VDC rated load voltage for: <ul style="list-style-type: none"> • Inserted power module, • Corresponding voltage group, • DO 0 and DO 1 and • Voltage buses P1 and P2
3	M	Ground
A 4	AUX 1	Any terminal for PE or voltage bus up to the maximum rated load voltage of the module
6	24 VDC	24 VDC rated load voltage for: <ul style="list-style-type: none"> • Inserted power module, • Corresponding voltage group, • DO 0 and DO 1 • and voltage buses P1 and P2
7	M	Ground
A 8	AUX 1	Any terminal for PE or voltage bus up to the maximum rated load voltage of the module
9	DO 0 P	Terminals for fail-safe digital output 0 (P/M switching)
10	DO 0 M	
11	DO 2 P	Terminals (relay contacts) for fail-safe switching of voltage buses P1 and P2 P1 and P2 can also be used as DO 2 M and DO 2 P
12	DO 2 M	
13	DO 1 P	Terminals for fail-safe digital output 1 (P/M switching)
14	DO 1 M	
15	DO 2 P	Terminals (relay contacts) for fail-safe switching of voltage buses P1 and P2 P1 and P2 can also be used as DO 2 M and DO 2 P
16	DO 2 M	



Caution

If strong currents can occur on DO 2 P and DO 2 M, both terminals 11 and 15 (DO 2 P) and terminals 12 and 16 (DO 2 M) must be wired in parallel.

Otherwise, the current loading could cause the terminals to heat up.

7.2.3 Wiring of the PM-E F pm DC24V PROFIsafe

Block Diagram

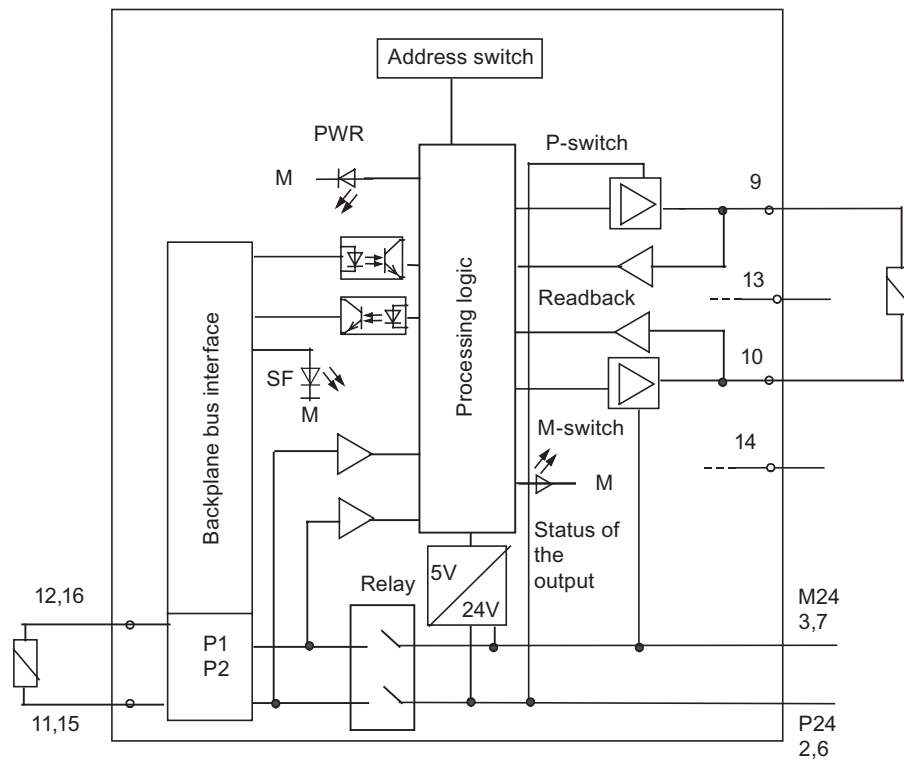

Figure 7-5 Block Diagram of the PM-E F pm DC24V PROFIsafe

Wiring Diagram

Each of the three digital outputs consists of a DOx P P-switch and a DOx M M-switch. They connect the load between P and M-switches. The two switches are always controlled so that voltage is applied to the load.

The wiring for the power module is carried out on the special terminal module.

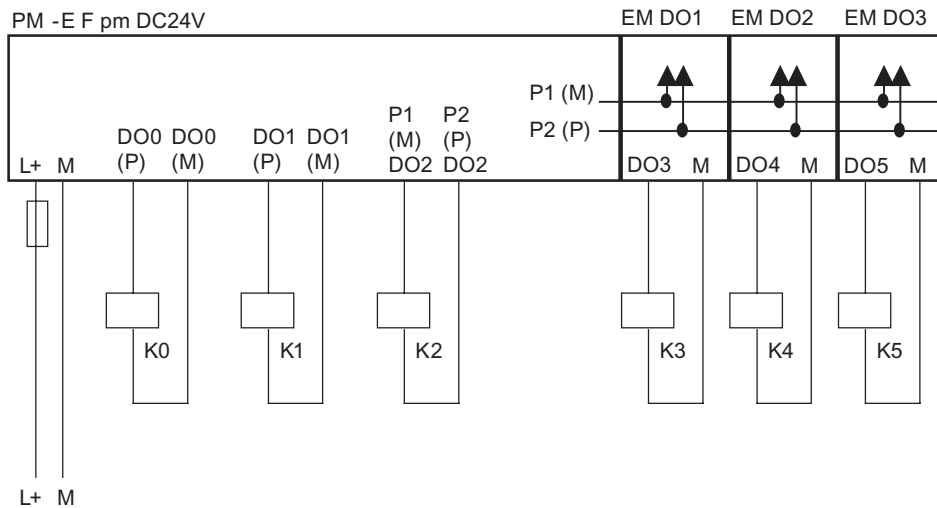

Figure 7-6 Wiring diagram of the PM-E F pm DC24V PROFIsafe



Warning

Please use an external fuse for L+ at the PM-E F pm with the following properties to protect the relay contact from overload: circuit-breaker of B characteristic as per IEC 947-5-1, 10 A.

Relay Output DO 2

The relay output DO 2 connects the voltage L+ and M using one relay contact for each. The voltage is fed outwards to the terminal module and to the internal voltage buses P1 and P2. This results in two connection options that can be used at the same time:

- A load can be connected directly to the terminal module (K2 in the figure above).
- Electronic modules can be supplied by means of the internal voltage buses P1 and P2. Loads can be connected to these modules in turn (K3, K4, K5 in the figure above).

Connection of Two Relays on One Digital Output

You can connect two relays using one fail-safe digital output. The following conditions should be kept in mind:

- L+ and M of the relays must be connected with L+ and M of the PM-E F pm (the same reference potential is necessary).
- The normally open contacts of the two relays must be connected in series.

This connection can only be made on digital outputs DO 0 and DO 1 (not DO 2). With this circuit, you achieve:

- AK6/SIL3/Category 4 without standard DO modules on P1 and P2
- AK4/SIL2/Category 3 with standard DO modules on P1 and P2

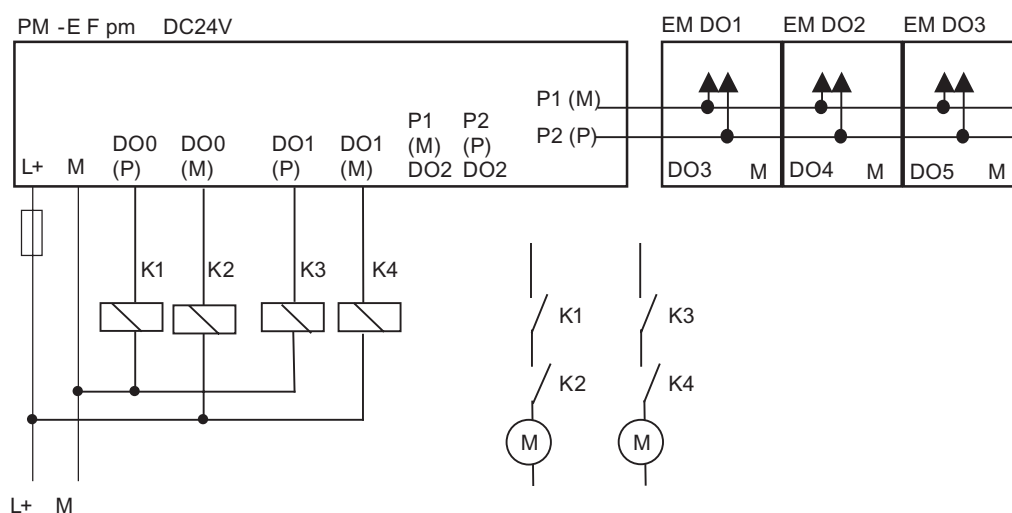

Figure 7-7 Wiring Diagram for Each of Two Relays on DO 0 and DO 1 of the PM-E F pm DC24V PROFIsafe



Warning

When connecting two relays to one digital output (as shown above), the "wire break" and "overload" faults are only detected at the output P-switch (not at the M-switch).



Warning

In the event of a cross circuit between the output P and M-switch the controlled actuator is no longer switched off. To avoid cross circuits between P and M-switches of a fail-safe digital output, you should connect the relay on the between P and M-switches to protect against cross circuits (for example with cables separately sheathed or in a separate cable duct).

Note

The PM-E F pm DC24V PROFIsafe performs a bit pattern test approximately every 15 minutes. The module generates a max. 4 ms pulse for this. This test is performed time staggered between the P and M switch, so that the actuator is not activated. However, the pulse may be picked up by respective relay, which can result in a reduced service life for the relay.

We therefore recommend the wiring scheme described in the following.

Avoiding/Dealing with Cross Circuits

To protect against cross circuits between P and M-switches of a fail-safe digital output, we recommend the following wiring schemes:

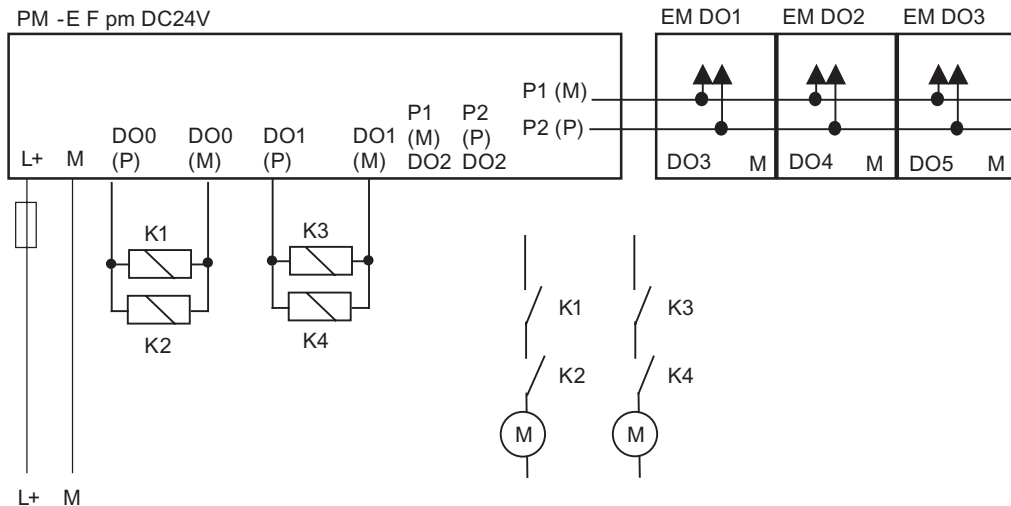

Figure 7-8 Wiring Diagram for Each of Two Relays on DO 0 and DO 1 of the PM-E F pm DC24V PROFIsafe

Note

With parallel connection of two relays to one digital output (as shown above), the "wire break" fault is only detect if the wire break disconnects both relays from P or M. This diagnosis is not safety-relevant.

7.2.4 Parameters of the PM-E F pm DC24V PROFIsafe

Parameters in STEP 7

The following table presents the parameters that can be assigned for the PM-E F pm 24 VDC PROFIsafe.

Table 7-4 Parameters of the PM-E F pm DC24V PROFIsafe

Parameter	Range	Default	Type of Parameter	Effective Range
F-Parameters:				
F_destination_address	1 to 1022	Assigned by STEP 7	Static	Module
F monitoring time	10 to 10000 ms	150 ms	Static	Module
Module Parameters:				
Behavior after channel faults*	Passivate the entire module/Passivate the channel	Passivate the entire module	Static	Module
Channel fault	Activated/deactivated	Activated	Static	Channel
Readback Time	1 to 400 ms	1 ms	Static	Channel
Diagnostics: Wire break	Activated/deactivated	Deactivated	Static	Channel
DO channel 1	Activated/deactivated	Activated	Static	Channel
Readback Time	1 to 400 ms	1 ms	Static	Channel
Diagnostics: Wire break	Activated/deactivated	Deactivated	Static	Channel
* This setting is only relevant when S7 Distributed Safety V5.4 or higher is installed.				

Readback Time Parameter

Each output channel has its own selectable readback time. This time specifies the maximum duration of the turn off test for the corresponding channel and therefore also the readback time for turning off the channel.

The following readback times can be set: 1 ms, 5 ms, 10 ms, 50 ms, 100 ms, 200 ms and 400 ms.

You should set an adequately high readback time if the channel involved switches high capacitive loads. If the readback time for a controlled capacitive load is set too low, the output channel is passivated because the discharge of the capacitance does not take place within the turn off test.

If the readback signals are incorrect, the "short circuit" fault causes passivation of the output channel after the readback time elapses.

Connecting capacitive loads

If the electronic outputs of the PM-E F pm DC24V PROFIsafe are connected to loads that require little current and have capacitance, this can lead to the "short circuit" error message. This is required because the capacitance cannot be sufficiently discharged during the set self-test readback time.

The following figure shows the typical curves of the selectable readback times indicating the relationship between load resistance and connectable load capacitance.

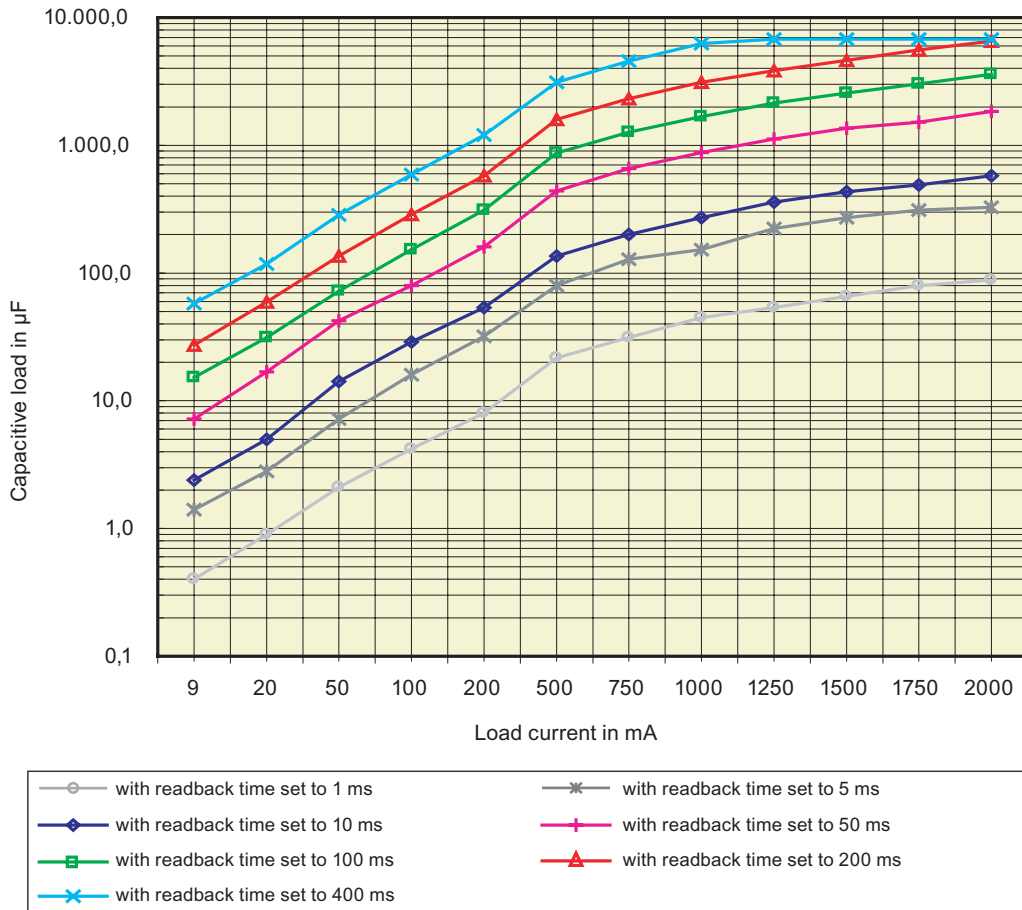

Figure 7-9 Relationship between Load Resistance and Connectable Load Capacitance for PM-E F pm DC24V PROFIsafe

Remedy:

1. Determine the load current and capacitance of the load.
2. Determine the operating point in the figure above.
3. If the operating point is above the curve, you must increase the load current until the new operating point is below the curve by connecting a resistor in parallel.

7.2.5 Diagnostic functions of the PM-E F pm DC24V PROFIsafe

Behavior in Case of Supply Voltage Failure

Failure of the power supply of the PM-E F pm DC24V PROFIsafe is always indicated by the PWR LED on the module (light off). This information is also provided in the module (diagnostic entry). Either all channels of the module are passivated or, in case of channel-level passivation, the relevant channels are passivated.

Diagnostic Functions

The following table presents an overview of the diagnostic functions of the PM-E F pm 24 VDC PROFIsafe power module. The diagnostic functions are assigned either to one channel or to the entire module.

Table 7-5 Diagnostic functions of the PM-E F pm DC24V PROFIsafe

Diagnostic Function*	Fault number	LED	Effective Range of Diagnostic	can be assigned parameters
Short circuit	1 _H	SF	Channel	No
Overload	4 _H	SF	Channel	No
Overtemperature	5 _H	SF	Module	No
Wire break	6 _H	SF	Channel	Yes
Internal error	9 _H	SF	Module	No
Parameter assignment error	10 _H	SF	Module	No
Missing external auxiliary supply	11 _H	PWR	Module	No
Communication error	13 _H	SF	Module	No
Safety-related shutdown	19 _H	SF	Channel	No
*: Specially for F-modules; display in <i>STEP 7</i> , see "Channel-Specific Diagnostics, Fault Types of Fail-Safe Modules" table				

Causes of Errors and Corrective Measures

The following table lists the possible causes of errors and corrective measures for the individual diagnostic messages of the PM-E F pm 24 VDC PROFIsafe power module.

Table 7-6 Causes of Errors and Corrective Measures for Diagnostic Messages of the PM-E F pm 24 VDC PROFIsafe

Diagnostic Message	Fault Detection	Possible Fault Causes	Corrective Measures
Short circuit	Always	Short circuit in the actuator	To correct short or cross circuit the module must be removed and inserted or switched on and off
		Cross-circuit in the actuator	
		Internal error	Replace module
		Short circuit in P1 and P2, because actuators connected to standard DO modules are not supplied by means of the terminal modules of the standard DO modules	Supply power to actuators on standard DO modules via terminal modules of the standard DO modules. Once the fault is eliminated, the module must be removed and inserted or the power switched off and on.
Overload	For "1" output signal only	Output stage is overloaded and becomes too hot	Eliminate the overload.
Over-temperature	Always	Shutdown due to violation of upper or lower temperature limit value in the module case.	Check load wiring, check ambient temperature, check whether permissible output current is exceeded at the ambient temperature. Once the fault is eliminated, the module must be removed and inserted or the power switched off and on.
Wire break	For "1" output signal only	Line break	Correct the process wiring, and check whether the output current is less than the minimum permissible output current of 20 mA
Internal error	Always	Internal module fault has occurred	Repair the wire break, ensure the specified minimum load (see technical specifications)
Parameter assignment error	Always	Inserted module does not match configuration incorrect parameters	Correct the configuration (compare actual and preset configuration), and check communication paths Correct the parameter assignment
		PROFIsafe address set incorrectly in the F-module	Check whether the PROFIsafe address on the module matches the configuration in <i>STEP 7 HW Config</i>
Missing external auxiliary supply	Always	No power supply or power too low (e.g. voltage dip at F-module)	Check module for correct contact, after correction of the fault the module must be removed and inserted or switched on and off

Diagnostic Message	Fault Detection	Possible Fault Causes	Corrective Measures
Communication error	Always	Error in communication between F-CPU and module, e.g. due to defective PROFIBUS connection or higher than permissible EMI	Check the PROFIBUS connection Eliminate the interference.
		PROFIsafe monitoring time set too low	Set a higher value for the "F monitoring time" parameter for the module in <i>STEP 7 HW Config</i>
		Configuration of the F-module does not match safety program	Generate safety program again; then download configuration and safety program to F-CPU again
Safety-related shutdown	Always	Switching frequency exceeded	Reduce the switching frequency or use a semiconductor output

Generally Applicable Information on Diagnostics

For information on diagnostics that pertains to all fail-safe modules (for example for reading out diagnostic functions, passivating channels), refer to *Chapter 7* in this manual.

See also

Fault Diagnostics (Page 5-3)

7.2.6 Technical Specifications for PM-E F pm 24 VDC PROFIsafe

Overview

Technical Specifications	
Dimensions and Weight	
Dimensions W x H x D (mm)	30 x 81 x 52
Weight	Approx. 88 g
Data for Specific Module	
Number of outputs	
• Semiconductor outputs (P-M switching)	2
• Relay outputs (P-M switching)	1
Assigned address area	
• In the I/O area for inputs	5 Byte
• In the I/O area for outputs	5 Byte
Length of cable*	
• Unshielded	200 m, maximum
• Shielded	200 m, maximum
Maximum achievable safety class	
• In accordance with IEC 61508, DIN VDE 0801, and EN 954	Max. SIL3, AK6, Category 4 (for conditions see "PM-E F pm DC24V PROFIsafe Power Module")
Fail-safe performance characteristics	SIL3
• Low demand mode (average probability of failure on demand)	< 1,00E-05
• High demand/continuous mode (probability of a dangerous failure per hour)	< 1,00E-05
Voltages, Currents, Potentials	
Rated supply voltage L+	24 VDC
• Permissible range	20.4 V to 28.8 V
• Power loss ride-through of L+	None
• Power loss ride-through of internal P5	5 ms
• Reverse polarity protection	No
Aggregate current	
• Horizontal installation	
– Up to 40 °C	10 A
– Up to 55 °C	7 A
– Up to 60 °C	6 A
• Vertical installation	
– Up to 40 °C	6 A
Electrical isolation	
• Between channels and backplane bus	Yes
• Between channels and power supply	No
• Between channels	No
• Between channels/power supply and shield	Yes

Technical Specifications	
Permissible potential difference between	
• Shield and ET 200S bus connection	75 VDC/60 VAC
• Shield and I/O (DOs, P1/P2 buses)	75 VDC/60 VAC
• ET 200S bus connection and I/O (DOs, P1/P2 buses)	250 VAC
Isolation in the series tested with	
• Shield and ET 200S bus connection	500 VDC/1 min or 600 VDC/1 s
• Shield and I/O (DOs, P1/P2 buses)	500 VDC/1 min or 600 VDC/1 s
• ET 200S bus connection and I/O (DOs, P1/P2 buses)	1500 VAC/1 min or 2545 VDC/1 s
Isolation in the type test tested with	
• Shield and ET 200S bus connection	350 VAC/1 min
• Shield and I/O (DOs, P1/P2 buses)	350 VAC/1 min
• ET 200S bus connection and I/O (DOs, P1/P2 buses)	2830 VAC/1 min
• Impulse current test between ET 200S bus connection and I/O (DOs, P1/P2 buses)	6000 VDC/5 positive and 5 negative pulses
Current consumption	
• From backplane bus	28 mA, maximum
• From load voltage L+ (without load)	100 mA, typical
Power dissipation of the module	4 W, typical
Status, Interrupts, Diagnostics	
Status display	<ul style="list-style-type: none"> • Green LED per channel • Green LED for the load voltage
Diagnostic functions	
• Group fault display	Red LED (SF)
• Diagnostic information can be displayed	Possible
Data for Selecting an Actuator for the Semiconductor Outputs**	
Output voltage	
• For "1" signal	<ul style="list-style-type: none"> • Minimum L+ (-2.0 V) • P-switch: minimum L+ (-1.5 V), voltage drop in M-switch: 0.5 V, maximum
Output current for "1" signal	
• Rated value	2 A
• Permissible range	20 mA to 2.4 A
For "0" signal (residual current)	0.5 mA, maximum
Indirect control of load by means of interface relay:	
Residual current for "0" signal	
• P-Switch	0.5 mA, maximum
• M-Switch	4 mA, maximum
Load resistance range	12 Ω to 1 k Ω
Lamp load	10 W, maximum

Technical Specifications		
Wire break monitoring (open load detection) and overload monitoring		
• Response threshold	I < 4 to 19 mA	
• Fault detection time	Depending on the selected readback time (see <i>Response Times</i>)	
Parallel connection of 2 outputs	Not possible	
Control of a digital input	Not possible	
Switching frequency		
• With resistive load	30 Hz symmetrical, maximum	
• With inductive load in accordance with IEC 947-5-1, DC13	0.1 Hz symmetrical, maximum	
• With lamp load	10 Hz symmetrical, maximum	
Voltage induced on current interruption limited to		
• Semiconductor outputs	L+ (-2x 47 V)	
• Relay outputs	P1/P2 (1 V)	
Short-circuit protection of semiconductor outputs	Yes, electronic	
• Response threshold of short circuit	5 A to 12 A	
• Response threshold (external M-short circuit)	5 A to 12 A	
• Response threshold (external P-short circuit)	25 A to 45 A	
Overload protection of semiconductor outputs	Yes	
• Response threshold	I > 2.6 A to 2.8 A	
Data for Selecting an Actuator for the Relay Outputs**		
Switching capacity and service life of contacts (voltage 24 VDC)		
• Mechanical endurance (without load)	Current	Number of switching cycles (typ.)
	0 A	10 million
• For resistive load	Current	Number of switching cycles (typ.)
	10 A	0.23 million
	8 A	0.3 million
	6 A	0.38 million
	4 A	0.5 million
	2 A	1.0 million
	1 A	2.0 million
• For inductive load in accordance with IEC 947-5-1, DC13	Current	Number of switching cycles (typ.)
	10 A	0.1 million
	8 A	0.15 million
	6 A	0.2 million
	4 A	0.3 million
	2 A	0.5 million
	1 A	1.0 million
• For lamp load	Power	Number of switching cycles (typ.)
	100 W	0.12 million

Technical Specifications	
Contact protection (internal)	Internal readback circuit
• Between P and M relay output	39 V suppressor diode
Wire break monitoring	No
Parallel connection of 2 outputs	Not possible
Control of a digital input	Not possible
Switching frequency	
• With resistive load	2 Hz, maximum
• With inductive load in accordance with IEC 947-5-1, DC13	0.1 Hz, maximum
• With lamp load	2 Hz, maximum
Short-circuit protection of output	No, external miniature circuit breaker, "B" characteristic (in accordance with IEC 947-5-1), 10 A required
Time, Frequency	
Internal preparation times	See <i>Response Times</i>
Acknowledgment time in safety mode	4 ms minimum/8 ms maximum
Protection against Overvoltage	
Protection of supply voltage L+ from surge in accordance with IEC 61000-4-5 with external protection elements only	
• Symmetrical (L+ to M)	+ 1 kV; 1,2/50 μ s
• Asymmetrical (L+ to PE, M to PE)	+2 kV; 1,2/50 μ s
Protection of outputs from surge in accordance with IEC 61000-4-5 with external protection elements only	
Symmetrical (DO to M)	+ 1 kV; 1,2/50 μ s
Asymmetrical (DO to PE, M to PE)	+ 1 kV; 1,2/50 μ s
*: In order to achieve the specified cable length, you must route the P- and M-signal lines in a cable or a non-metallic sheathed cable.	
**: For more information on the requirements for sensors and actuators see <i>Wiring and Installing Modules</i> .	

7.3 PM-E F pp DC24V PROFIsafe power module

7.3.1 Properties of the PM-E F pp DC24V PROFIsafe Power Module

Order Number

6ES7 138-4CF41-0AB0

properties

The PM-E F pp 24 VDC PROFIsafe power module has the following properties:

- Two relays for connecting voltage bus P2, 10 A output current
- Relay contacts must be fused externally
- 24 VDC rated load voltage
- Suitable for solenoid valves, DC contactors, and indicator lights
- Suitable for applications for which a grounded configuration is necessary or in which a not-grounded configuration cannot be guaranteed
- Group fault display (SF; red LED)
- Status display for voltage bus P2 (green LED)
- Status display for load current power supply (PWR; green LED)
- Assignable diagnostics
- For achievable safety classes (safety integrity level), see following table

Table 7-7 Overview of Achievable Safety Classes (Safety Integrity Levels) with PM-E F pp DC24V PROFIsafe

PM-E F pp DC24V PROFIsafe			Maximum Safety Level That Can Be Achieved
Relay outputs P1 and P2	Without standard DO modules	Signal switches daily or more often	AK6/ SIL3/Category 4
		Signal switches less than once a day	AK4/ SIL2/ Category 3
	with standard DO modules		AK4/ SIL2/ Category 3

Switching the P2 Voltage Rail

The power module can switch the P2 voltage rail fail-safe with two series connected relay contacts in accordance with AK4/SIL2/Cat.3 and AK6/SIL3/Cat.4. P2 is available as P on the terminal module, P1 as M.

Conditions for Achieving Safety Class

The conditions for achieving the respective safety classes are summarized in the following table.

Table 7-8 PM-E F pp DC24V PROFIsafe: Conditions for AK/SIL/Category

Condition	Achievable AK/SIL/Category
ET 200S standard modules supplied by means of P2	AK4/SIL2/Category 3 on P2
The relays are switched at least once during the time of occurrence of the second fault; power is not supplied to ET 200S standard modules via P2	AK6/SIL3/Category 4 on P2

Power Module Supplies for Standard ET 200S Modules



Warning

Always connect the 24 VDC supply for the standard ET 200S modules on the PM-E F pp DC24V PROFIsafe. Otherwise, the outputs of DO modules may exhibit safety critical behavior.



Warning

When supplying standard DO modules, always use the terminal modules to supply actuators (actuator feedback on the DO module). Otherwise, the power module signals a short circuit and the load voltage of this voltage group is interrupted.

Double Chassis Cable Necessary



Warning

For the PM-E F pp DC24V PROFIsafe, the chassis cable to the terminal module must be installed twice for safety reasons. Otherwise if there was an interruption on a single chassis cable, a safety-related shutdown of voltage bus P2 would not be possible.

Safety-Related Shutdown of Standard DO Modules



Warning

The following ET 200S standard modules are approved for safety-related shutdown in accordance with SIL2:

- 2DO DC24V/0.5A (order number 6ES7 132-4BB01-0AA0 or higher)
 - 2DO DC24V/2A (order number 6ES7 132-4BB31-0AA0 or higher)
 - 2DO DC24V/0.5A HIGH FEATURE (order number 6ES7 132-4BB01-0AB0 or higher)
 - 2DO DC24V/2A HIGH FEATURE (order number 6ES7 132-4BB31-0AB0 or higher)
 - 4DO DC24V/0.5A (order number 6ES7 132-4BD00-0AA0 or higher)
 - 4DO DC24V/2A (order number 6ES7 132-4BD31-0AA0 or higher)
-



Warning

Safety-related activation of outputs of standard DO modules is not possible; rather, only safety-related **shutdown** is possible. You must therefore take the following effects into account:

In the worst case you must consider all possible faults of the standard DO modules and the programs controlling them for which the faults cannot be found directly. For example, the PM-E F pp DC24V PROFIsafe does not detect external short-circuits as per L+ at the standard DO module outputs.

All errors of the standard DO modules influence the process via final control elements.

The process must be made known to the F-CPU via sensors and a suitable safety program.

The safety program must react in a safety-related and logically suitable fashion to unwanted or potentially dangerous states in the process via the PM-E F pp DC24V PROFIsafe and fail-safe output modules.

If you want to avoid the problems described above completely, we recommend that you use P/M switching fail-safe electronic modules 4 F-DO DC24V/2A PROFIsafe with standard ET 200S power modules instead of standard DO modules.

Property of the safety-related shutdown of standard DO modules by the PM-E F pp DC24V PROFIsafe:

With this cost-effective solution, when a fault is discovered in the process or on the PM-E F pp DC24V PROFIsafe, there is a comprehensive and simultaneous shutdown of all outputs involved.

Property of individual shutdown of F-modules with fail-safe outputs:

If a fault is discovered, the extent of the shutdown is kept to a minimum. It is also possible to react to critical process states staggered over time or outputs can be shut down individually and safety-related. This solution is expensive compared with the safety-related shutdown by the PM-E F pp DC24V PROFIsafe.

See also

Assigning Modules of an ET 200S (Page 2-4)

Properties of the 4 F-DO DC24V/2A PROFIsafe digital electronic module (Page 7-80)

7.3.2 Terminal assignment of the PM-E F pp DC24V PROFIsafe

Incoming Supply of the 24 VDC Supply for Electronic Modules with Process-Related Functions

Depending on whether the electronic and load current supplies are electrically isolated in the electronic modules with process-related functions (positioning, counting), you must adhere to the following wiring instructions:

- If electrically isolated, provide an external 24 VDC feed for the electronic module.
- If electrical isolation is not implemented, you must supply the electronic module from the voltage bus P2 of the PM-E F pp 24 VDC PROFIsafe power module.

AK4/SIL2/Category 3 is attainable in both cases.

Front View

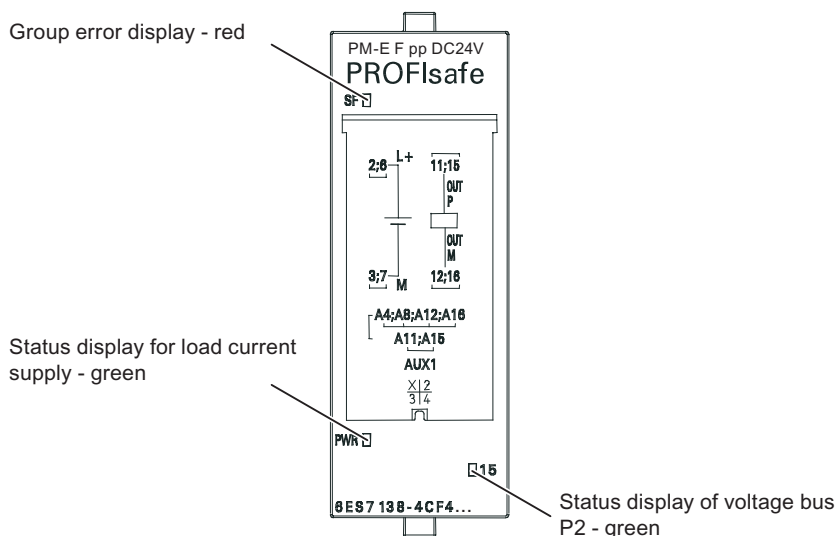

Figure 7-10 PM-E F pp DC24V PROFIsafe front view



Warning

The SF LED and the status displays of the outputs must not be evaluated for safety-related activities.

Terminal assignment

The terminal assignment of the PM-E F pp 24 VDC PROFIsafe power module for the usable terminal modules TM-P30S44-A0 and TM-P30C44-A0 is shown in the following figure and table.

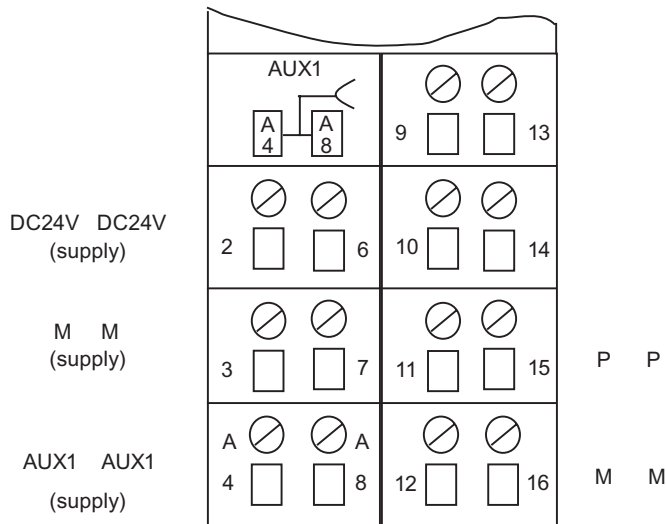

Figure 7-11 Terminal Assignment of the TM-P30S44-A0 or TM-P30C44-A0 for PM-E F pp DC 24V PROFIsafe

Table 7-9 Table-Terminal Assignment of the TM-P30S44-A0 or TM-P30C44-A0

Terminal	Designation	Designation
2	24 VDC	24 VDC rated load voltage for: <ul style="list-style-type: none"> • Inserted power module, • Corresponding voltage group and • Voltage bus P2
3	M	Ground
A 4	AUX 1	Any terminal for PE or voltage bus up to the maximum rated load voltage of the module
6	24 VDC	24 VDC rated load voltage for: <ul style="list-style-type: none"> • Inserted power module, • Corresponding voltage group and • Voltage bus P2
7	M	Ground
A 8	AUX 1	Any terminal for PE or voltage bus up to the maximum rated load voltage of the module
11	P	Terminals (relay contacts) for fail-safe connection of voltage bus P2
12	M	
15	P	Terminals (relay contacts) for fail-safe connection of voltage bus P2
16	M	



Caution

If high currents can occur on DO 2 P and DO 2 M, both terminals 11 and 15 (P) and terminals 12 and 16 (M) must be wired in parallel.

Otherwise, the current loading could cause the terminals to heat up.

7.3.3 Wiring of the PM-E F pp DC24V PROFIsafe

Block Diagram

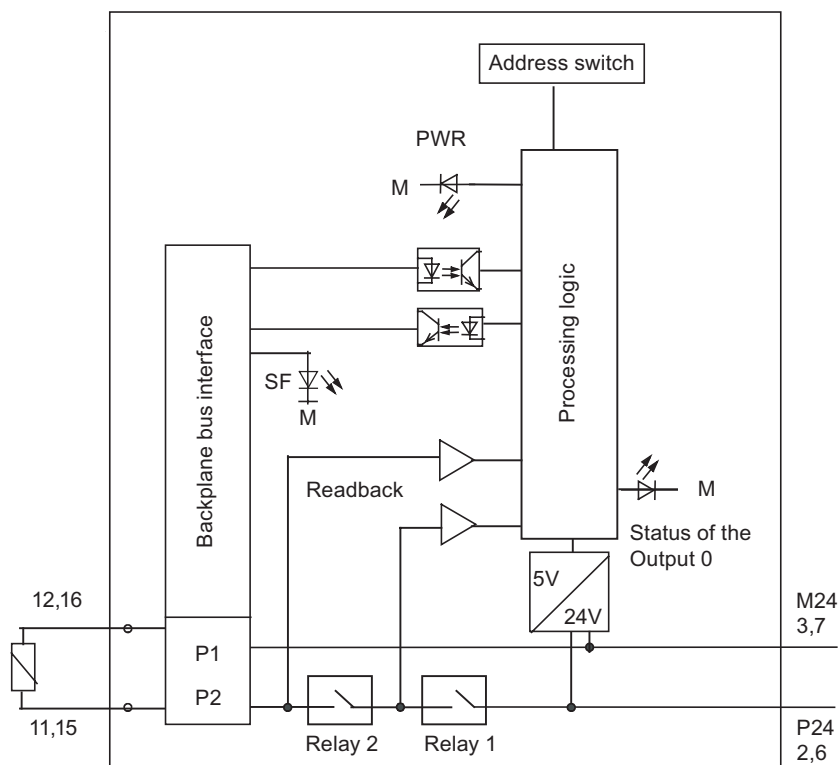

Figure 7-12 Block Diagram of the PM-E F pp DC24V PROFIsafe

Wiring Diagram

The wiring for the power module is carried out on the special terminal module.

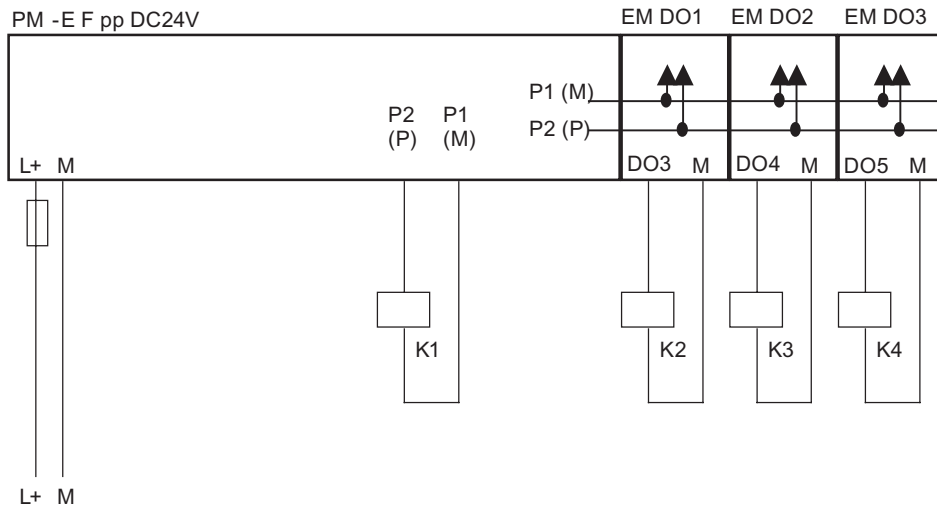

Figure 7-13 Wiring diagram of the PM-E F pp DC24V PROFIsafe



Warning

Please use an external fuse for L+ at the PM-E F pp with the following properties to protect the relay contact from overload: circuit-breaker of B characteristic as per IEC 947-5-1, 10 A.

Relay output

The relay output connects the L+ voltage over two relay contacts. The connected voltage is fed outwards to the terminal module and to the internal voltage buses P1 and P2. This results in two connection options that can be used at the same time:

- A load can be connected directly to the terminal module (K1 in the figure above).
- Electronic modules can be supplied by means of the internal voltage buses P1 and P2. Loads can be connected to these modules in turn (K2, K3, K4 in the figure above).

7.3.4 Parameters of the PM-E F pp DC24V PROFIsafe

Parameters in *STEP 7*

The following table presents the parameters that can be assigned for the PM-E F pp 24 VDC PROFIsafe.

Table 7-10 Parameters of the PM-E F pp DC24V PROFIsafe

Parameter	Range	Default	Type of Parameter	Effective Range
F-Parameters:				
F_destination_address	1 to 1022	Assigned by STEP 7	Static	Module
F monitoring time	10 to 10000 ms	150 ms	Static	Module

See also

Configuration and Parameter Assignment (Page 2-8)

7.3.5 Diagnostic functions of the PM-E F pp DC24V PROFIsafe

Behavior in Case of Supply Voltage Failure

Failure of the power supply of the PM-E F pp DC24V PROFIsafe is always indicated by the PWR LED on the module (light off). This information is also provided in the module (diagnostic entry). The relay output of the module is passivated.

Diagnostic Functions

The following table presents an overview of the diagnostic functions of the PM-E F pp 24 VDC PROFIsafe power module. The diagnostic functions are assigned either to one channel or to the entire module.

Table 7-11 Diagnostic functions of the PM-E F pp DC24V PROFIsafe

Diagnostic Function*	Fault Number	LED	Effective Range of Diagnostic	Assign-able
Short circuit	1 _H	SF	Channel	No
Overtemperature	5 _H	SF	Module	No
Internal fault	9 _H	SF	Module	No
Parameter assignment error	10 _H	SF	Module	No
Missing external auxiliary supply	11 _H	PWR	Module	No
Communication error	13 _H	SF	Module	No
Safety-related shutdown	19 _H	SF	Channel	No
*: Specially for F-modules; display in <i>STEP 7</i> , see "Channel-Specific Diagnostics, Fault Types of Fail-Safe Modules" table				

Causes of Faults and Corrective Measures

The following table lists the possible causes of faults and corrective measures for the individual diagnostic messages of the PM-E F pp 24 VDC PROFIsafe.

Table 7-12 Causes of Faults and Corrective Measures for Diagnostic Messages of the PM-E F pp 24 VDC PROFIsafe

Diagnostic Message	Fault Detection	Possible Fault Causes	Corrective Measures
Short circuit	Always	Cross circuit between P1 and L+	To correct cross circuit the module must be removed and inserted or switched on and off
Over-temperature	Always	Shutdown due to violation of upper or lower temperature limit value in the module case.	Check load wiring, check ambient temperature, check whether permissible output current is exceeded at the ambient temperature. Once the fault is eliminated, the module must be removed and inserted or the power switched off and on.
Internal fault	Always	Internal module fault has occurred	Replace module
Parameter assignment error	Always	Inserted module does not match configuration, incorrect parameter assignment	Correct the configuration (compare actual and preset configuration), and check communication paths. Correct the parameter assignment.
		PROFIsafe address set incorrectly on the F-module	Check whether the PROFIsafe address on the module matches the configuration in <i>STEP 7 HW Config</i>
Missing external auxiliary supply	Always	No power supply or power too low (e.g., voltage dip at F-module)	Check module for correct contact After correction of the fault the module must be removed and inserted or switched off and on
Communication error	Always	Error in communication between F-CPU and module, e.g., due to defective PROFIBUS connection or higher than permissible EMI	Test PROFIBUS connection. Correct faults.
		PROFIsafe monitoring time set too low	Set a higher value for the "F monitoring time" parameter for the module in <i>STEP 7 HW Config</i>
		Configuration of the F-module does not match safety program	Generate safety program again; then download configuration and safety program to F-CPU again
Safety-related shutdown	Always	Switching frequency exceeded	Reduce the switching frequency

Generally Applicable Information on Diagnostics

For information on diagnostics that pertains to all fail-safe modules (for example for reading out diagnostic functions, passivating channels), refer to *Diagnostics*.

See also

Fault Diagnostics (Page 5-3)

7.3.6 Technical Specifications for the PM-E F pp 24 VDC PROFIsafe

Overview

Technical Specifications	
Dimensions and Weight	
Dimensions W x H x D (mm)	30 x 81 x 52
Weight	Approx. 80 g
Data for Specific Module	
Number of outputs	
• Relay outputs (PP switching)	1
Assigned address area	
• In the I/O area for inputs	5 Byte
• In the I/O area for outputs	5 Byte
Length of cable	
• Unshielded	200 m, maximum
• Shielded	200 m, maximum
Maximum achievable safety class	
• In accordance with IEC 61508, DIN VDE 0801, and EN 954	Max. SIL3, AK6, Category 4 (for conditions see "PM-E F pp DC24V PROFIsafe Power Module")
Fail-safe performance characteristics	SIL3
• Low demand mode (average probability of failure on demand)	< 1,00E-05
• High demand/continuous mode (probability of a dangerous failure per hour)	< 1,00E-05
Voltages, Currents, Potentials	
Rated supply voltage L+	24 VDC
• Permissible range	20.4 V to 28.8 V
• Power loss ride-through of L+	None
• Power loss ride-through of internal P5	5 ms
• Reverse polarity protection	No
Total current of the relay output	
• Horizontal installation	
– Up to 40 °C	10 A
– Up to 55 °C	8 A

Technical Specifications		
– Up to 60 °C	7 A	
• Vertical installation – Up to 40 °C	8 A	
Electrical isolation		
• Between output and backplane bus	Yes	
• Between output and power supply	No	
• Between output/power supply and shield	Yes	
Permissible potential difference between		
• Shield and ET 200S bus connection	75 VDC/60 VAC	
• Shield and I/O (DOs, P1/P2 buses)	75 VDC/60 VAC	
• ET 200S bus connection and I/O (DOs, P1/P2 buses)	250 VAC	
Isolation in the series tested with		
• Shield and ET 200S bus connection	500 VDC/1 min or 600 VDC/1 s	
• Shield and I/O (DOs, P1/P2 buses)	500 VDC/1 min or 600 VDC/1 s	
• ET 200S bus connection and I/O (DOs, P1/P2 buses)	1500 VAC/1 min or 2545 VDC/1 s	
Isolation in the type test tested with		
• Shield and ET 200S bus connection	350 VAC/1 min	
• Shield and I/O (DOs, P1/P2 buses)	350 VAC/1 min	
• ET 200S bus connection and I/O (DOs, P1/P2 buses)	2830 VAC/1 min	
• Impulse current test between ET 200S bus connection and I/O (DOs, P1/P2 buses)	6000 VDC/5 positive and 5 negative pulses	
Current consumption		
• From backplane bus	28 mA, maximum	
• From load voltage L+ (without load)	100 mA, typical	
Power dissipation of the module	4 W, typical	
Status, Interrupts, Diagnostics		
Status display	<ul style="list-style-type: none"> • Green LED per channel • Green LED for the load voltage 	
Diagnostic Functions		
• Group fault display	Red LED (SF)	
• Diagnostic information can be displayed	Possible	
Data for Selecting an Actuator for the Relay Output*		
Switching capacity and service life of contacts (voltage 24 VDC)		
• Mechanical endurance (without load)	Current	Number of switching cycles (typ.)
	0 A	10 million
• For resistive load	Current	Number of switching cycles (typ.)
	10 A	0.23 million
	8 A	0.3 million
	6 A	0.38 million
	4 A	0.5 million

Technical Specifications		
	2 A	1.0 million
	1 A	2.0 million
• For inductive load in accordance with IEC 947-5-1, DC13	Current	Number of switching cycles (typ.)
	10 A	0.1 million
	8 A	0.15 million
	6 A	0.2 million
	4 A	0.3 million
	2 A	0.5 million
	1 A	1.0 million
• For lamp load	Power	Number of switching cycles (typ.)
	100 W	0.12 million
Contact protection (internal)	Internal readback circuit	
• Between PP relay output and M	39 V suppressor diode	
Wire break monitoring	No	
Parallel connection of 2 outputs	Not possible	
Control of a digital input	Possible	
Switching frequency		
• With resistive load	2 Hz symmetrical, maximum	
• With inductive load in accordance with IEC 947-5-1, DC13	0.1 Hz symmetrical, maximum	
• With lamp load	2 Hz symmetrical, maximum	
Short-circuit protection of output	No, external miniature circuit breaker, "B" characteristic (in accordance with IEC 947-5-1), 10 A required	
Time, Frequency		
Internal preparation times	See <i>Response Times</i>	
Acknowledgment time in safety mode	4 ms minimum/8 ms maximum	
Protection against Overvoltage		
Protection of power supply L+ from surge in accordance with IEC 61000-4-5 with external protection elements only		
• Symmetrical (L+ to M)	+ 1 kV; 1,2/50 µs	
• Asymmetrical (L+ to PE, M to PE)	+2 kV; 1,2/50 µs	
Protection of outputs from surge in accordance with IEC 61000-4-5 with external protection elements only		
Symmetrical (DO to M)	+ 1 kV; 1,2/50 µs	
Asymmetrical (DO to PE, M to PE)	+ 1 kV; 1,2/50 µs	
*: For more information on the requirements for sensors and actuators see <i>Wiring and Installing Modules</i> .		

7.4 PM-D F DC24V PROFIsafe power module

7.4.1 Properties of the PM-D F DC24V PROFIsafe Power Module

Order Number

3RK1 903-3BA01

Properties

The PM-D F 24 VDC PROFIsafe power module has the following properties:

- 6 safety groups SG 1 through SG 6
- Output current of SG 1 through SG 6, each 3 A (total current 5 A)
- Rated load voltage DC 24 V per safety group
- Suitable for the supply of:
 - Fail-safe motor starters F-DS1e-x, F-RS1e-x,
 - Fail-safe frequency converters F-FU
 - Fail-safe connection multipliers F-CM,
 - Fail-safe power/expansion modules PM-D F X1.
 - Brake Control expansion modules xB1, xB2, xB3 and xB4
- Group fault display (SF; red LED)
- Status display per safety group (SG 1 through SG 6; green LED)
- Status display for load current power supply (PWR; green LED)
- Status display for electronic power supply (U1; green LED)
- Achievable safety class (safety integrity level) AK6/SIL3/Category 4

Switching the Voltage Buses SG 1 through SG 6 and U 1

The power module can shut down voltage buses SG 1 through SG 6 over 6 digital outputs complying with safety class (safety integrity level) AK4/SIL2/Category 3 or AK6/SIL3/Category 4. The outputs are implemented with two P switches. There is a main switch for all 6 safety groups and 6 individual switches connected in series per safety group.

The voltage bus U 1 (electronics power supply for the motor starters) is supplied with 24 V DC. **With overvoltage or undervoltage** U 1 is switched off by two P switches and the downstream motor starters are passivated. **In the event of a safety shut down** the motor starter is U 1 not shut down.

Conditions for Achieving Safety Class

The conditions for achieving the respective safety classes are summarized in the following table.

Table 7-13 PM-D F DC24V PROFIsafe: Conditions for AK/SIL/Category

Condition	Achievable AK/SIL/Category
Fail-safe motor starters are expanded with the expansion modules: <ul style="list-style-type: none">• Brake Control xB3 and xB4	AK4/ SIL2/ Category 3
Power supply of: <ul style="list-style-type: none">• Exclusively fail-safe F-DS1e-x motor starters and F-RS1e-x,• Fail-safe frequency converters F-FU• Fail-safe connection multipliers F-CM• Fail-safe power/expansion modules PM-D F X1. Fail-safe motor starters are expanded with the expansion modules: Brake Control xB1 and xB2	AK6/ SIL3/Category 4

Note

The safety classes (safety integrity levels) AK4/SIL2/Category 3 or AK6/SIL3/Category 4 can only be achieved with the modules specified in the "Condition" column. Configurations with other modules (for example motor starter DS1-x/RS1x, DS1e-x/RS1e-x, DSS1e-x) are not permitted for safety-related applications.

7.4.2 Terminal assignment of the PM-D F DC24V PROFIsafe

Front View

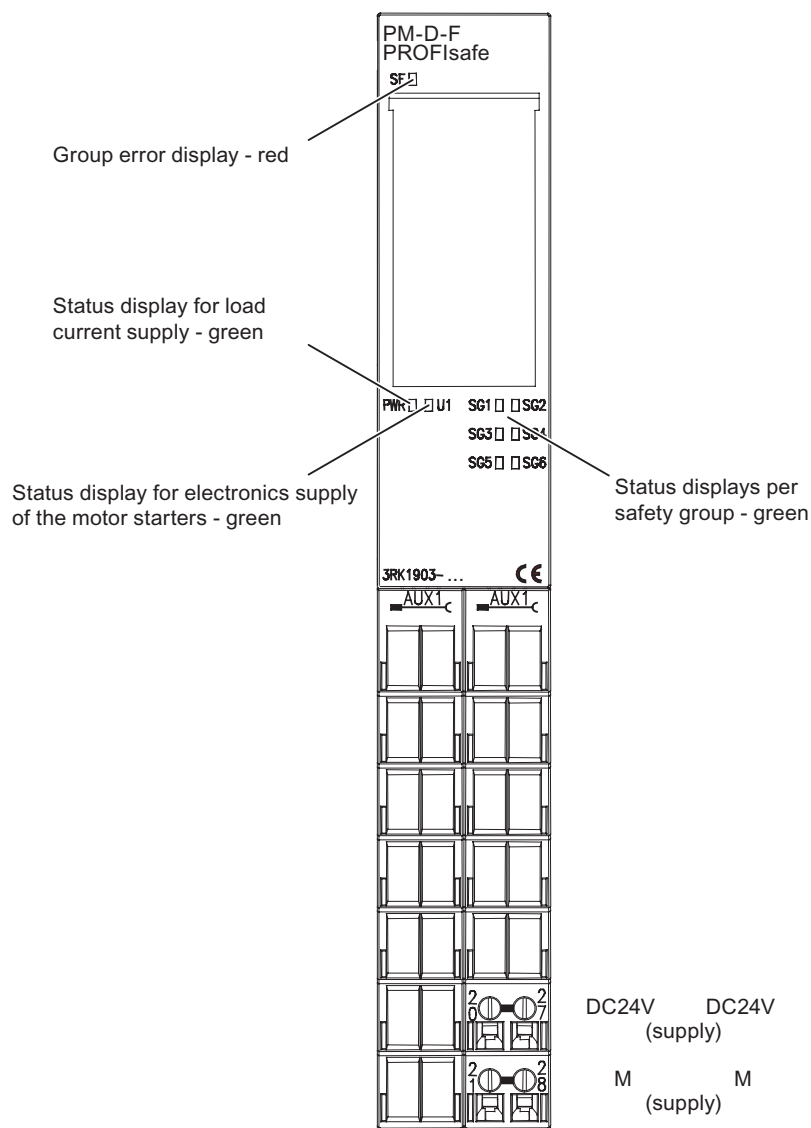

Figure 7-14 PM-D F DC24V PROFIsafe front view



Warning

The SF LED and the status displays of the outputs must not be evaluated for safety-related activities.

Terminal assignment

On the PM-D F DC24V PROFIsafe, you connect only the 24 V DC load voltage power supply and chassis. The power module is wired on the special terminal module.

The following table shows the terminal assignment of the PM-D F DC24V PROFIsafe for the permitted terminal module TM-PF30S47-F1 (order number 3RK1 903-3AA00).

Table 7-14 Terminal Assignment of the TM-PF30S47-F1

Terminal		Designation
20	24 VDC	24 VDC rated load voltage for: <ul style="list-style-type: none">• Inserted power module and• Voltage buses SG 1 through SG 6 and U 1
21	M	Ground
27	24 VDC	24 VDC rated load voltage for: <ul style="list-style-type: none">• Inserted power module and• Voltage buses SG 1 through SG 6 and U 1
28	M	Ground

7.4.3 Wiring of the PM-D F DC24V PROFIsafe

Block Diagram

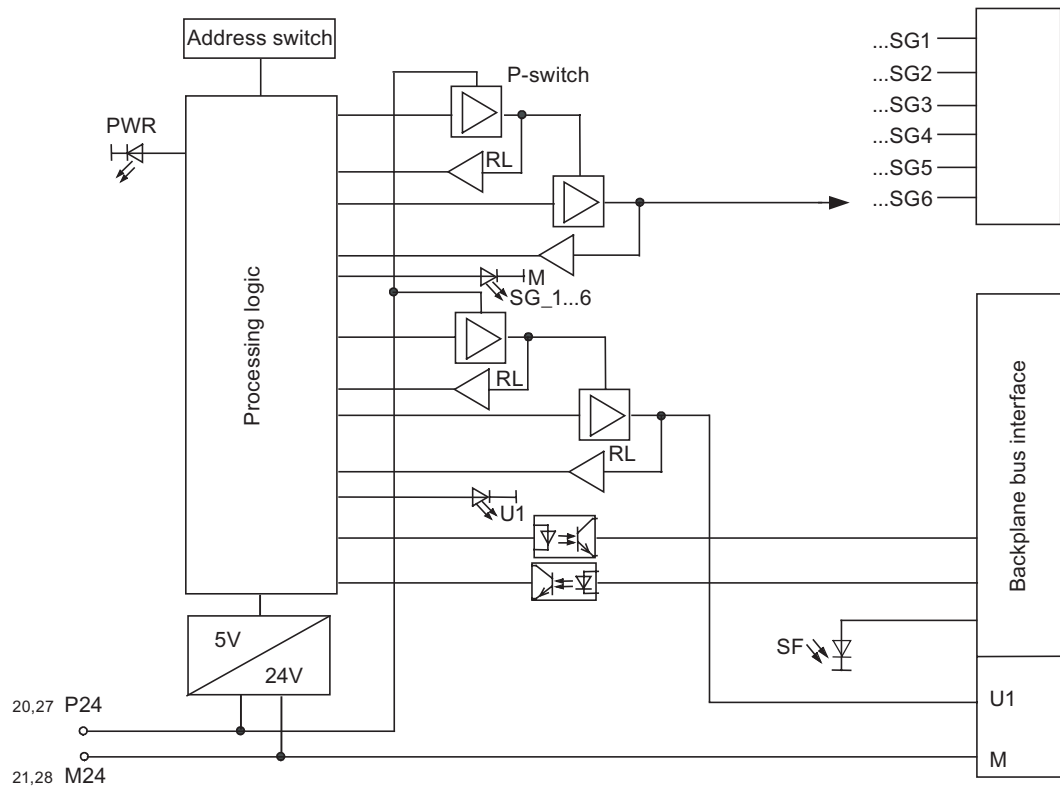

Figure 7-15 Block diagram of the PM-D F DC24V PROFIsafe

7.4.4 Parameters of the PM-D F DC24V PROFIsafe

Parameters in STEP 7

The following table presents the parameters that can be assigned for the PM-D F 24 VDC PROFIsafe.

Table 7-15 Parameters of the PM-D F DC24V PROFIsafe

Parameter	Range	Default	Type of Parameter	Effective Range
F-Parameters:				
F_destination_address	1 to 1022	Assigned by STEP 7	Static	Module
F monitoring time	10 to 10000 ms	150 ms	Static	Module
Module Parameters:				
Behavior after channel faults*	Passivate the entire module/ Passivate the channel	Passivate the entire module	Static	Module
* This setting is only relevant when S7 Distributed Safety V5.4 or higher is installed.				

7.4.5 Diagnostic Functions of PM-D F DC24V PROFIsafe

Behavior in Case of Supply Voltage Failure

A load current power supply failure in the PM-D F DC24V PROFIsafe is always indicated by the PWR LED on the module (light is off). The failure of the electronics power supply is indicated by the U1 LED on the module (no longer lit). This information is also provided on the module (diagnostic entry). All shutdown groups of the module (SG 1 through SG 6) are passivated or, in the case of channel-level passivation, the relevant shutdown groups are passivated.

If there is a dip in the load current power supply, the PWR-LED is no longer lit, the supplied safety groups are passivated. When the power supply later recovers, the PWR LED remains off, the safety groups remain passivated. The PWR LED only lights up again after the ET 200S has restarted (turn the power to the ET 200S off and on again or remove and reinsert the power module with the load voltage turned off), the safety groups are active again.

Diagnostic Functions

The following table shows an overview of the diagnostic functions of the PM-D F DC24V PROFIsafe power module. The diagnostic functions are assigned either to one channel or to the entire module.

Table 7-16 Diagnostic Functions of PM-D F DC24V PROFIsafe

Diagnostic Function*	Fault Number	LED	Effective Range of Diagnostic	Assign-able
Short circuit	1 _H	SF	Channel	No
Overtemperature	5 _H	SF	Module	No
Internal fault	9 _H	SF	Module	No
Parameter assignment error	10 _H	SF	Module	No
Missing external auxiliary supply	11 _H	PWR	Module	No
Communication error	13 _H	SF	Module	No
*: Specially for F-modules; display in <i>STEP 7</i> , see "Channel-Specific Diagnostics, Fault Types of Fail-Safe Modules" table				

Causes of Faults and Corrective Measures

The following table lists the possible causes of faults and corrective measures for the individual diagnostic messages of the PM-D F DC24V PROFIsafe power module.

Table 7-17 Causes of Faults and Corrective Measures for Diagnostic Messages of the PM-D F DC24V PROFIsafe

Diagnostic Message	Fault Detection	Possible Fault Causes	Corrective Measures
Short circuit	Always	Short circuit in the actuator	To correct short or cross circuit the module must be removed and inserted or switched on and off
		Cross-circuit in the actuator	
		Internal fault	Replace module
Over-temperature	Always	Shutdown due to violation of upper and lower temperature limit values in the module case.	Check load wiring, check ambient temperature. Once the fault is eliminated, the module must be removed and inserted or switched off and on.
Internal fault	Always	Internal module fault has occurred	Replace module
Parameter assignment error	Always	Inserted module does not match configuration. Incorrect parameter assignment.	Correct the configuration (compare actual and preset configuration), and check communication paths. Correct the parameter assignment.
		PROFIsafe address set incorrectly on the F-module	Check whether the PROFIsafe address on the module matches the configuration in <i>STEP 7 HW Config</i>
Missing external auxiliary supply	Always	No supply voltage or supply voltage is too low	Check module for correct contact After correction of the fault the module must be removed and inserted or switched off and on
Communication error	Always	Error in communication between F-CPU and module, e.g., due to defective PROFIBUS connection or higher than permissible EMI	Test PROFIBUS connection. Correct faults.
		PROFIsafe monitoring time set too low	Set a higher value for the "F monitoring time" parameter for the module in <i>STEP 7 HW Config</i>

Generally Applicable Information on Diagnostics

For information on diagnostics that pertains to all fail-safe modules (for example for reading out diagnostic functions, passivating channels), refer to *Chapter 7* in this manual.

See also

Fault Diagnostics (Page 5-3)

7.4.6 Technical Specifications of the PM-D F DC24V PROFIsafe

Overview

Technical Specifications	
Dimensions and Weight	
Dimensions W x H x D (mm)	30 x 196.5 x 117.5
Weight	Approx. 112 g
Data for Specific Module	
Number of outputs (P/P switching)	6 safety groups (SG 1 through SG 6)
Internal power supply for bus	U 1
Assigned address area	
• In the I/O area for inputs	5 Byte
• In the I/O area for outputs	5 Byte
Maximum achievable safety class	
• In accordance with IEC 61508, DIN VDE 0801, and EN 954	SIL3, AK6, Category 4
Fail-safe performance characteristics	SIL3
• Low demand mode (average probability of failure on demand)	< 1,00E-05
• High demand/continuous mode (probability of a dangerous failure per hour)	< 1,00E-05
Voltages, Currents, Potentials	
Rated supply voltage L+	24 VDC
• Permissible range	21.6 V to 26.4 V
• Power loss ride-through of L+	None
• Power loss ride-through of internal P5	5 ms
• Reverse polarity protection	No
Aggregate current of outputs	
• Horizontal installation	Brief/permanent
– Up to 40 °C	10 A/5 A
– Up to 60 °C	10 A/4 A
• Vertical installation	Brief/permanent
– Up to 40 °C	10 A/4 A
Electrical isolation	
• Between channels and backplane bus	Yes
• Between channels and power supply	No
• Between channels	No
• Between channels/power supply and shield	Yes
Permissible potential difference between	
• Shield and ET 200S bus connection	75 VDC/60 VAC
• Shield and I/O (SGs, U 1 bus)	75 VDC/60 VAC
• ET 200S bus terminal and I/O (SGs, U 1 bus)	250 VAC

Technical Specifications	
Isolation in the series tested with	
• Shield and ET 200S bus connection	500 VDC/1 min or 600 VDC/1 s
• Shield and I/O (SGs, U 1 bus)	500 VDC/1 min or 600 VDC/1 s
• ET 200S bus terminal and I/O (SGs, U 1 bus)	1500 VAC/1 min or 2545 VDC/1 s
Isolation in the type test tested with	
• Shield and ET 200S bus connection	350 VAC/1 min
• Shield and I/O (SGs, U 1 bus)	350 VAC/1 min
• ET 200S bus terminal and I/O (SGs, U 1 bus)	2830 VAC/1 min
• Surge test between ET 200S bus terminal and I/O (SGs, U 1 bus)	6000 VDC/5 positive and 5 negative pulses
Current consumption	
• From backplane bus	28 mA, maximum
• From load voltage L+ (without load)	100 mA, typical
Power dissipation of the module	4 W, typical
Status, Interrupts, Diagnostics	
Status display	<ul style="list-style-type: none"> • Green LED per SG • Green LED for electronic power supply • Green LED for the load voltage
Diagnostic Functions	
• Group fault display	Red LED (SF)
• Diagnostic information can be displayed	Possible
Time, Frequency	
Internal preparation times	See <i>Response Times</i>
Acknowledgment time in safety mode	4 ms minimum/8 ms maximum
Protection against Overvoltage	
Protection of supply voltage L+ from surge in accordance with IEC 61000-4-5 with external protection elements only	
• Symmetrical (L+ to M)	+ 1 kV; 1,2/50 µs
• Asymmetrical (L+ to PE, M to PE)	+2 kV; 1,2/50 µs

7.5 4/8 F-DI VDC24V PROFIsafe Digital Electronic Module

7.5.1 Properties of the 4/8 F-DI 24 VDC PROFIsafe Digital Electronic Module

Order Number

6ES7 138-4FA02-0AB0

properties

The 4/8 F-DI 24 VDC PROFIsafe digital electronic module has the following properties:

- Eight inputs (AK4/SIL2/Category 3) or four inputs (AK6/SIL3/Category 3 or 4)
- 24 VDC rated input voltage
- Suitable for switches and 3 or 4-wire proximity switches (BEROs)
- Two short-circuit-proof sensor supplies for each of the four inputs
- External sensor supply possible
- Group fault display (SF; red LED)
- Status display for each input (green LED)
- One fault display for each sensor supply (1VsF and 2VsF; red LED)
- Assignable diagnostics

Power Modules for SIL2 or SIL3

Table 7-18 EM 4/8 F-DI DC24V PROFIsafe: Power Modules for AK/SIL/Category

Power module	Achievable AK/SIL/Category
Supply using PM-E 24 VDC	With 1oo1 evaluation of the sensors (8 F-DI) AK4/SIL2/Category 3
Power supply from PM-E DC24..48V/AC24..230V	With 1oo1 evaluation of the sensors (8 F-DI) AK4/SIL2/Cat.3 with 1oo2 evaluation of sensors (4 F-DI) AK6/SIL3/Cat.4
Power supply by PM-E DC24..48V	With 1oo1 evaluation of the sensors (8 F-DI) AK4/SIL2/Cat.3 with 1oo2 evaluation of sensors (4 F-DI) AK6/SIL3/Cat.4

Capacitive Crosstalk of Digital Input/Output Signals

See *Properties of the PM-E F pm DC24V PROFIsafe Power Module*

7.5.2 Terminal assignment of the EM 4/8 F-DI DC24V PROFIsafe

Front View

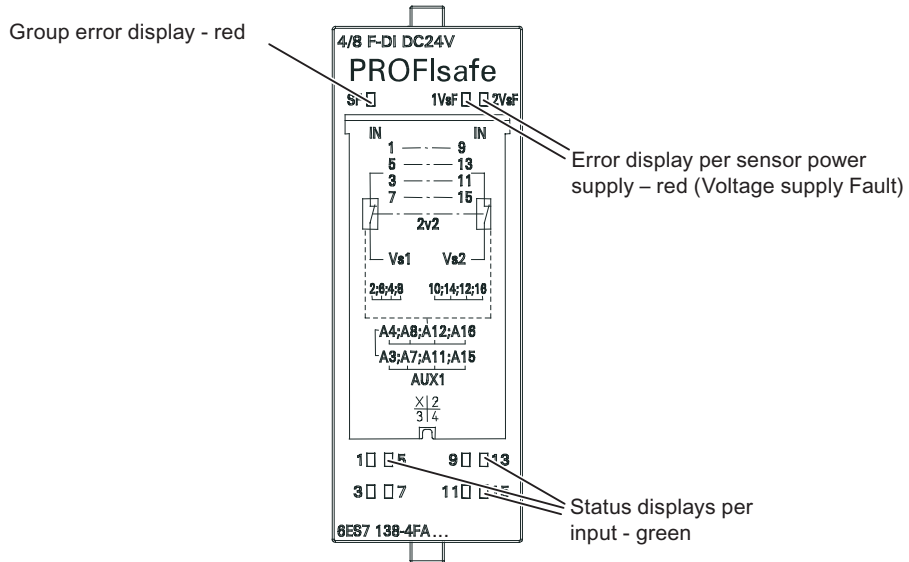

Figure 7-16 Front View of EM 4/8 F-DI DC24V PROFIsafe

Terminal assignment

The terminal assignment of the EM 4/8 F-DI 24 VDC PROFIsafe for the applicable terminal modules TM-E30S44-01, TM-E30C44-01, TM-E30S46-A1, and TM-E30C46-A1 is shown in the following figure.

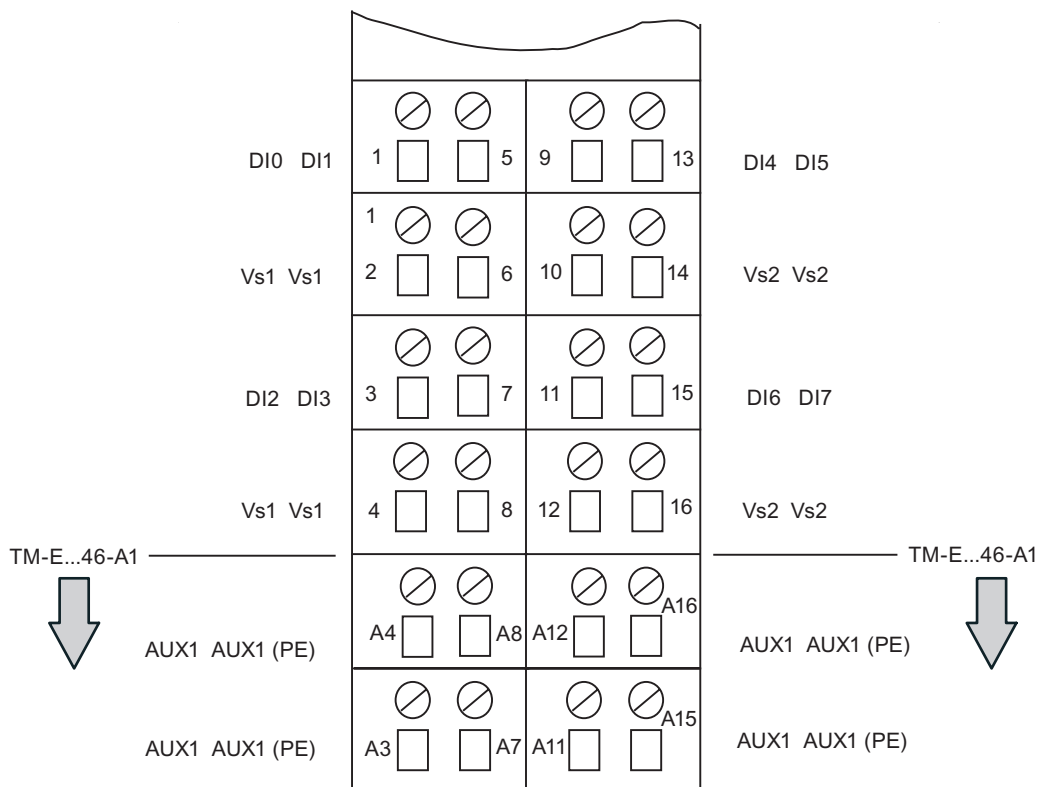

Figure 7-17 Terminal Assignment of TM-E...44-01/TM-E...46-A1 for EM 4/8 F-DI DC24V PROFIsafe

- DI Fail-safe digital input
- Vs1 Internal sensor power supply 1 for DI 0 to DI 3
- Vs1 Internal sensor power supply 2 for DI 4 to DI 7

at TM-E...46-A1: AUX 1 bus implemented. Connection to terminals A3 through A16 for any connection of PE (individual grouping of sensor power supplies possible)

7.5.3 Wiring of the EM 4/8 F-DI 24 VDC PROFIsafe

Block Diagram

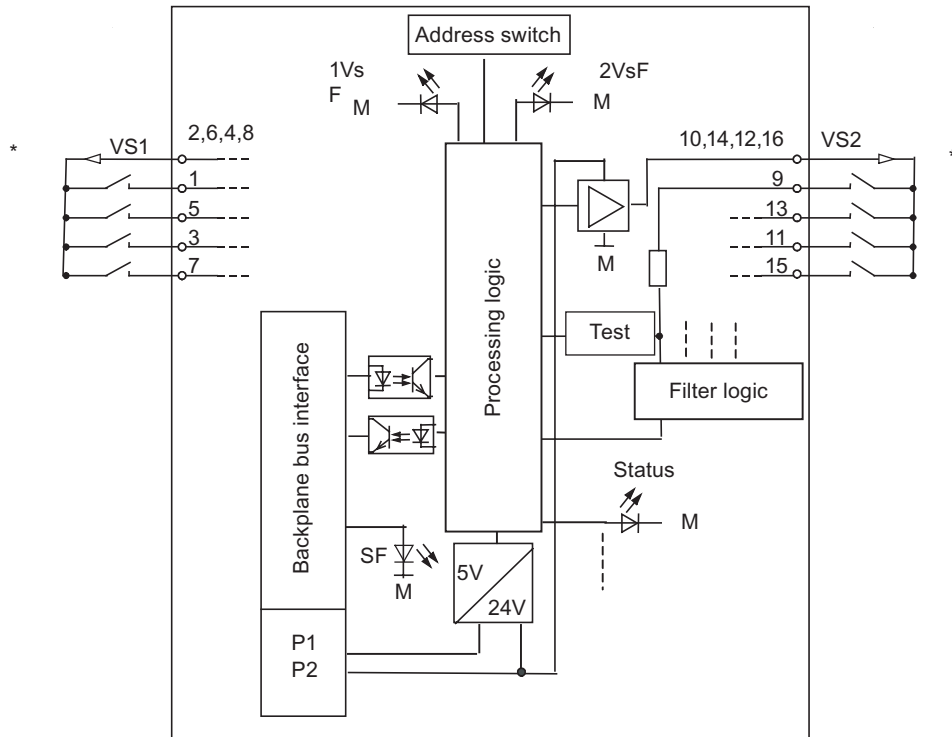

* The representation of the NO contacts is as printed on the module. Generally, however, the sensor contacts must be NC contacts (due to safe state of the process variables).

Figure 7-18 Block Diagram of EM 4/8 F-DI DC24V PROFIsafe

7.5.4 Parameters of the EM 4/8 F-DI DC24V PROFIsafe

Parameters in *STEP 7*

The following table presents the parameters that can be assigned for the EM 4/8 F-DI 24 VDC PROFIsafe.

Table 7-19 Parameters of the EM 4/8 F-DI DC24V PROFIsafe

Parameter	Range	Default	Type of Parameter	Effective Range
F-Parameters:				
F_destination_address	1 to 1022	Assigned by STEP 7	Static	Module
F monitoring time	10 to 10000 ms	150 ms	Static	Module
Module Parameters:				
Input delay	0.5; 3; 15 ms	3 ms	Static	Module
Short-circuit test	Cyclic/blocked	Cyclic	Static	Module
Behavior after channel faults*	Passivate the entire module/Passivate the channel	Passivate the entire module	Static	Module
Channel n, n+4	Activated/deactivated	Activated	Static	Channel Group
Evaluation of the Sensors	1oo2 evaluation/ 1oo1 evaluation	1oo2 Evaluation	Static	Channel Group
Type of sensor interconnection	1-channel; 2-channel equivalent; 2-channel, non-equivalent	2-channel equivalent	Static	Channel Group
Discrepancy response	Provide last valid value; provide 0 value	Provide last valid value	Static	Channel Group
Discrepancy Time	10 to 30000 ms	10 ms	Static	Channel Group
* This setting is only relevant when S7 Distributed Safety V5.4 or higher is installed.				

Input Delay of 3 ms Parameter

Note

With 3 ms input delay shielded cables must be used if there is a danger of overvoltage on the signal lines (see "Electromagnetic Compatibility") to prevent possible passivation of the fail-safe digital inputs and the sensor power supply shutdown.

If unshielded signal lines are used the safe behavior of the process quantities is ensured.

Short-Circuit Test Parameter

The cyclic short-circuit test is activated or deactivated using the short-circuit test parameter. The short-circuit test is only useful for simple switches that do not have their own power supply. If the short-circuit test has been activated, the internal sensor power supplies must be used (see also *"Use Cases of the 4/8 F-DI DC24V PROFIsafe Electronic Module"*).

Behavior of discrepancy Parameter

As the "Behavior of discrepancy", you set the value that is made available to the safety program in the F-CPU while there is a discrepancy between the two input channels involved; in other words, during the discrepancy time. You set the behavior of discrepancy as follows:

- "Provide last valid value" or
- "Provide 0 Value"

Requirements

You have set the following:

- Evaluation of the Sensors: "1oo2 evaluation" and
- Type of sensor interconnection: "2-channel equivalent" or "2-channel non-equivalent"

"Provide last valid value"

The last valid value (old value) before discrepancy occurs is made available in the safety program in the fail-safe CPU as soon as a discrepancy is detected between the signals of the affected input channels. This value remains available until the discrepancy disappears or until the discrepancy time expires and a discrepancy error is detected. The sensor-actuator response time is extended according to the this time.

As a result, the discrepancy time of sensors connected over two channels must be set for fast responses to short response times. It makes no sense, for example, if sensors connected over two channels with a discrepancy time of 500 ms trigger a time-critical shutdown. In the worst case, the sensor-actuator response time is extended by an amount approximately equal to the discrepancy time:

- For this reason, position the sensor in the process in such a way as to **minimize** discrepancy.
- Then select the **shortest possible** discrepancy time that also has sufficient back-up against false tripping of discrepancy errors.

"Provide 0 Value"

The value "0" is immediately made available to the safety program in the F-CPU as soon as a discrepancy is detected between the signals of the two affected input channels.

If you assigned the parameter "Provide 0 value" , the sensor-actuator response time will not be affected by the discrepancy time.

Discrepancy Time Parameter

Here, you can specify the discrepancy time for each pair of channels. The input value is rounded to a multiple of 10 ms.

Requirements

You have set the following:

- Evaluation of the Sensors: "1oo2 evaluation" and
- Type of sensor interconnection: "2-channel equivalent" or "2-channel non-equivalent"

Discrepancy Analysis and Discrepancy Time

If you use a 2-channel, one non-equivalent, or two 1-channel sensors, that measure the same physical process variable, the sensors will respond with a slight time delay among each other due to the limited accuracy of the arrangement.

The discrepancy analysis for equality/non-equality is used with fail-safe inputs to detect errors based on the timing of two signals with the same functionality. Discrepancy analysis starts when different levels (when checking for non-equality: the same level) of two related input signals are detected. The signals are checked to establish whether the difference (when checking for non-quality: the match) has disappeared following a selectable time known as the discrepancy time. If not, a discrepancy error is recognized.

The most cases, the discrepancy time is started but is not elapse fully since the signal differences disappear after a short time.

Select the discrepancy time large enough so that in case of no error the difference of the two signals (when checking for non-equivalence: signals matching) has disappeared in every case before the discrepancy time is elapsed.

Response While the Discrepancy Time Is Running

While the discrepancy time is running internally on the module, either the **last valid value** or **"0"** is provided for the safety program on the F-CPU by the input channels involved depending on the parameter settings for the behavior of discrepancy.

Response after the Discrepancy Time Elapses

If there is no match of the input signals after elapse of the specified discrepancy time (when checking for non-equivalence: inequality), for example due to a break in the sensor wire, a discrepancy error is detected and the "discrepancy" diagnostic message is generated in the diagnostic buffer of the F-I/O module indicating the faulty channels.

7.5.5 Applications for 4/8 F-DI 24 VDC PROFIsafe Digital Electronic Module

Selecting the Application

The following figure provides information to help you select the application that corresponds to your fail-safe requirements. The following chapters provide instructions for each application on wiring the F-module and requirements for specific parameter settings in *STEP 7*.

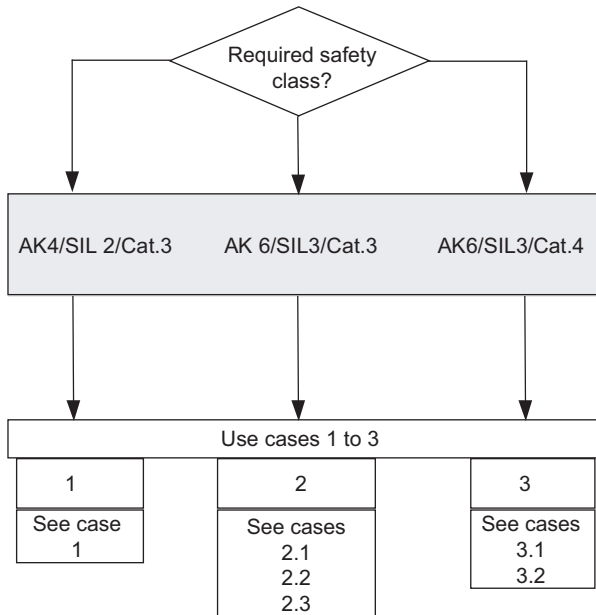

Figure 7-19 Selecting a Use Case - 4/8 F-DI DC24V PROFIsafe Electronic Module



Warning

The achievable safety class depends on the sensor quality and the size of the proof test interval in accordance with IEC 61508. If the sensor quality is less than the required safety class, the sensor must be installed redundantly and connected over two channels.

Conditions for Achieving AK/SIL/Category

The conditions for achieving the respective safety requirements are presented in the following table.

Table 7-20 EM 4/8 F-DI DC24V PROFIsafe: Conditions for Achieving AK/SIL/Category

Application	Sensors	Evaluation of the Sensors	Sensor Supply	Achievable AK/SIL/Category
1	1-channel	1oo1	Internal, with short-circuit test	4 / 2 / 3
			Internal, without short-circuit test	
			External	
2.1	1-channel	1oo2	Internal, with short-circuit test	6 / 3 / 3
			Internal, without short-circuit test	
			External	
2.2	2-channel equivalent	1oo2	Internal, without short-circuit test	
			External	
2.3	2-channel, non-equivalent	1oo2	Internal, without short-circuit test	
			External	
3.1	2-channel equivalent	1oo2	Internal, with short-circuit test	6 / 3 / 4
3.2	2-channel, non-equivalent			

Note

You can operate the various inputs of an F-DI module simultaneously in AK4/SIL2/Category 3 **and** in AK6/SIL3/Category 3 or 4. You only have to connect the inputs and assign parameters as shown in the following chapters.

Sensor Requirements

When using sensors for safety-related applications, please note the information in *Requirements for Sensors and Actuators*.

7.5.6 Application 1: Safety Mode AK4/SIL2/Category 3

Sensor Supply

The EM 4/8 F-DI 24 VDC PROFIsafe provides sensor supply Vs1 for inputs 0 to 3 and sensor supply Vs2 for inputs 4 to 7. The sensor supply can be provided internally or externally.

Wiring Diagram for Application 1 - Connecting One Sensor to One Channel

One 1-channel sensor (1oo1 evaluation) is connected for each process signal.

The wiring is carried out on the appropriate terminal module.

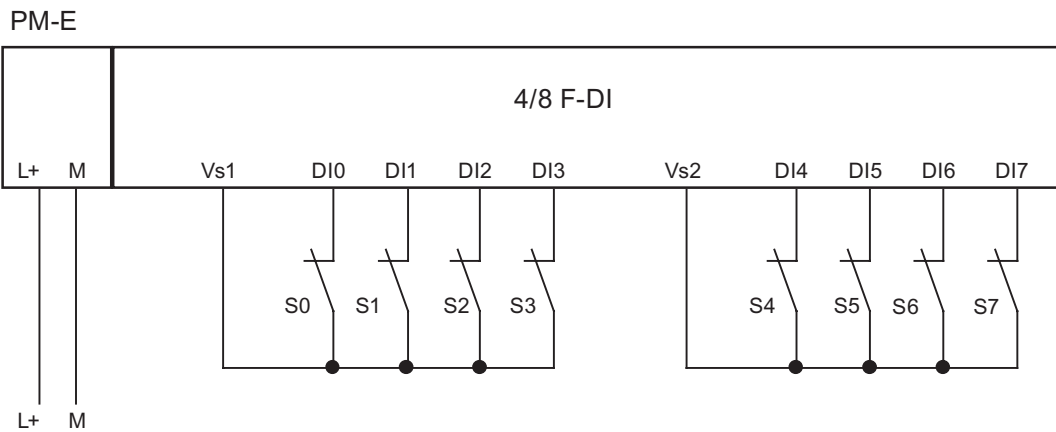

Figure 7-20 Wiring Diagram for EM 4/8 F-DI DC24V PROFIsafe - One Sensor Connected via One Channel, Internal Sensor Supply

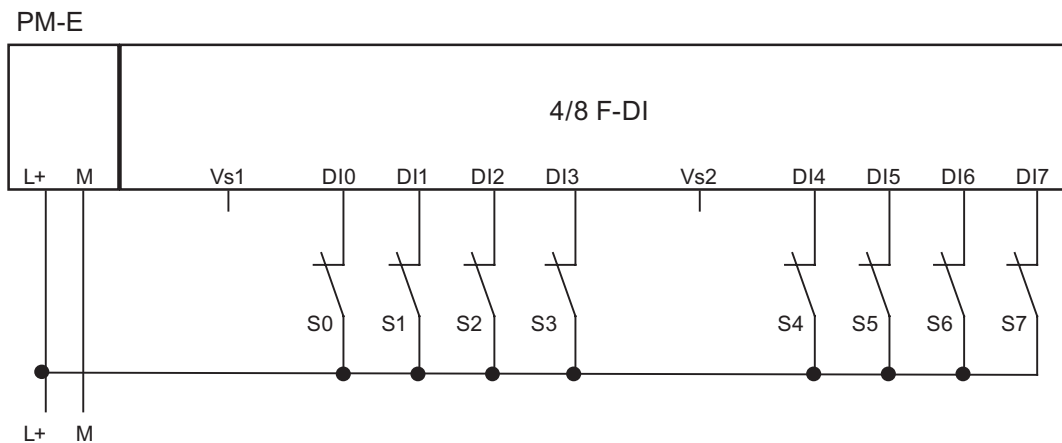

Figure 7-21 Wiring Diagram EM 4/8 F-DI DC24V PROFIsafe - One Sensor 1-Channel Connected, External Sensor Power Supply

Assignable Parameters for Use Case 1

Set the parameter "Evaluation of sensor" to "1oo1 evaluation" for the respective input.

You can activate or deactivate the "short-circuit test" parameter. However, you must deactivate the short-circuit test as soon as one or more fail-safe digital inputs are **externally** supplied. Otherwise the "short circuit" diagnosis may be reported.

Special Features of Fault Detection (Use Case 1)

The following table presents fault detection according to the sensor supply and the parameter assignment for the short-circuit test:

Table 7-21 EM 4/8 F-DI DC24V PROFIsafe: Fault Detection (Application 1)

Example of fault	Fault detection when ...		
	Internal sensor power supply and activated short-circuit test	Internal Sensor Supply and Deactivated Short-Circuit Test	External sensor supply
Short circuit in DI 0 with DI 1	No	No	No
Short circuit in DI 0 with DI 4	Yes*	No	No
P-short circuit in DI 0	Yes	No	No
M-short circuit in DI 0	Yes*	Yes*	No
Discrepancy error	-	-	-
P-short current in sensor supply 1	Yes	No	No
M-short circuit in sensor supply 1, or sensor supply 2 defective	Yes	Yes	Yes
Short circuit in sensor supply 1 with sensor supply 2	Yes	No	No
Fault in read/test circuit	Yes	Yes	Yes
Supply voltage fault	Yes	Yes	Yes

*: Fault is detected only in case of signal corruption. That is, the signal read differs from the sensor signal. If there is no signal corruption with respect to the sensor signal, fault detection is not possible and is not required from a safety standpoint.



Warning

If the short-circuit test is disabled or cannot be enabled, you must install the wire between the sensor and input channel in a short-circuit-proof manner.

7.5.7 Application 2: Safety Mode AK6/SIL3/Category 3

Assigning Inputs to Each Other

The EM 4/8 F-DI DC24V PROFIsafe has 8 fail-safe inputs DI 0 to DI 7 (SIL2). A pair of these inputs can each be used as one input (SIL3). The following assignment applies:

- DI 0 with DI 4
- DI 1 with DI 5
- DI 2 with DI 6
- DI 3 with DI 7

Sensor Supply

The EM 4/8 F-DI 24 VDC PROFIsafe provides sensor supply Vs1 for inputs 0 to 3 and sensor supply Vs2 for inputs 4 to 7. The sensor power supply can be provided internally or externally.

Wiring Diagram for Use Case 2.1 - Connecting one channel of one sensor to two inputs

One channel of a sensor is connected to two inputs of the F-module for each process signal (1oo2 evaluation).

Note

If the voltage is supplied to the sensor by the F-DI module, you must use the internal sensor supply Vs1. Connection to Vs2 is not possible.

The wiring is carried out on the appropriate terminal module.

PM-E

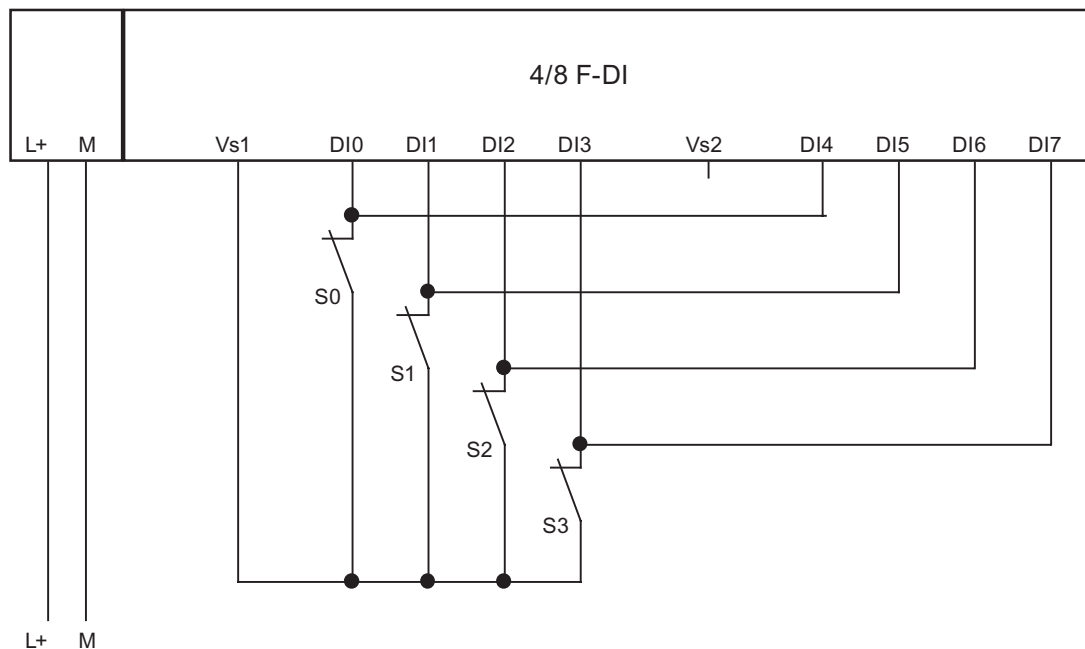

Figure 7-22 Wiring Diagram for EM 4/8 F-DI 24 VDC - One Sensor Connected to Two Inputs via One Channel, Internal Sensor Supply

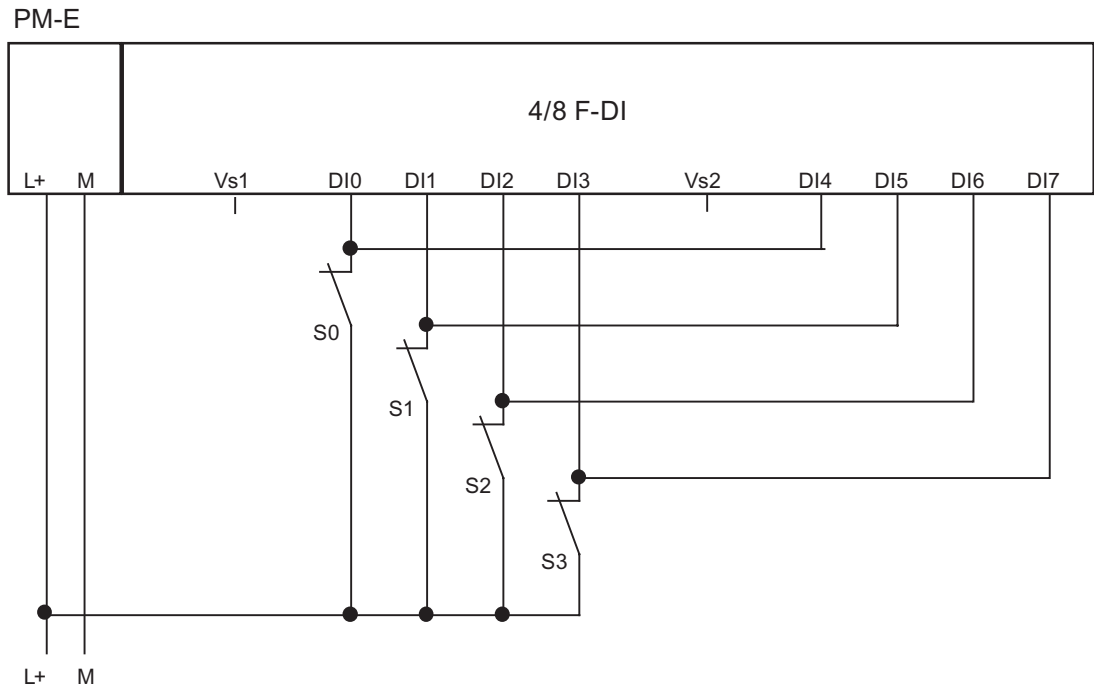

Figure 7-23 Wiring Diagram EM 4/8 F-DI DC24V - One Channel of a Sensor Connected to Two Inputs, External Power Supply



Warning

To achieve AK6/SIL3/Category 3 using this wiring, you must use a sensor qualified for this class.

Assignable Parameters for Use Case 2.1

Set the parameter "evaluation of sensors" to "1oo2 evaluation" for the corresponding sensor and the parameter "type of sensor interconnection" to "1-channel" . The discrepancy time is permanently preset to 10 ms and cannot be changed.

You can activate or deactivate the "short-circuit test" parameter. However, you must deactivate the short-circuit test as soon as one or more fail-safe digital inputs are **externally** supplied. Otherwise the "short circuit" diagnosis may be reported.

Special Features of Fault Detection (Use Case 2.1)

The following table presents fault detection according to the sensor supply and the parameter assignment for the short-circuit test:

Table 7-22 EM 4/8 F-DI DC24V PROFIsafe: Fault Detection (Application 2.1)

Example of fault	Fault detection when ...		
	Internal sensor power supply and activated short-circuit test	Internal Sensor Supply and Deactivated Short-Circuit Test	External Sensor Supply
Short circuit in DI 0 with DI 1	No	No	No
Short circuit in DI 0 with DI 5	No	No	No
P-short circuit in DI 0	Yes	No	No
M-short circuit in DI 0	Yes*	Yes*	No
Discrepancy error	Yes	Yes	Yes
P-short current in sensor supply 1	Yes	No	No
M-short circuit in sensor supply 1, or sensor supply 2 defective	Yes	Yes	Yes
Short circuit in sensor supply 1 with sensor supply 2	Yes	No	No
Fault in read/test circuit	Yes	Yes	Yes
Supply voltage fault	Yes	Yes	Yes

*: Fault is detected only in case of signal corruption. In other words, the signal read differs from the sensor signal (discrepancy error). If there is no signal corruption with respect to the sensor signal, fault detection is not possible and is not required from a safety standpoint.



Warning

If the short-circuit test is disabled or cannot be enabled, you must install the wire between the sensor and input channel in a short-circuit-proof manner.

Wiring Diagram for Application 2.2 - Connecting a Two-channel Sensor to Two Channels

Two channels of a 2-channel sensor are connected to two inputs of the F-module for each process signal (1oo2 evaluation).

The wiring is carried out on the appropriate terminal module.

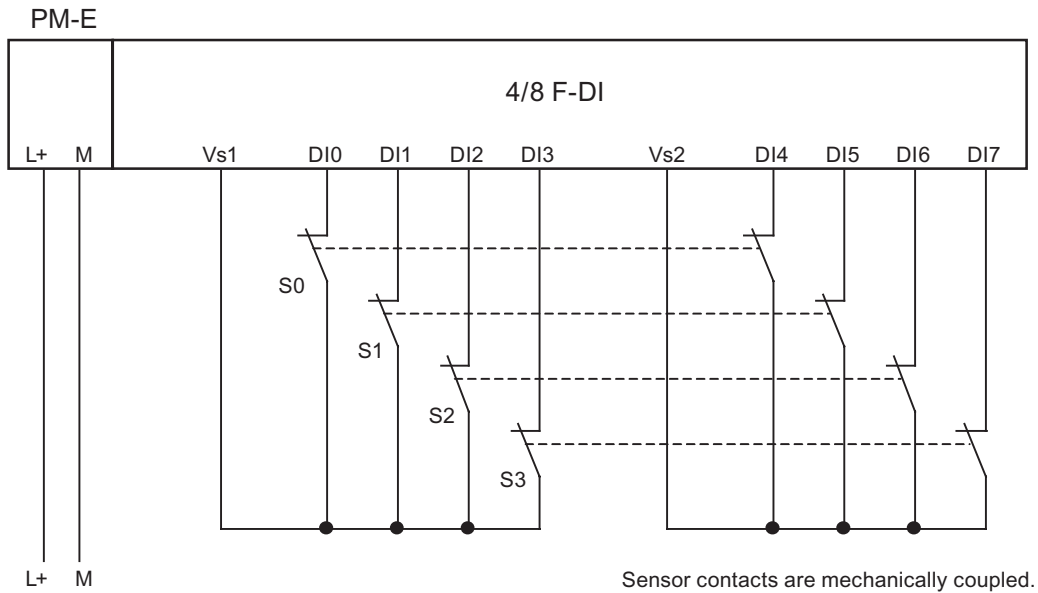

Figure 7-24 Wiring Diagram for EM 4/8 F-DI DC24V - One Two-Channel Sensor Connected via Two Channels, Internal Sensor Supply

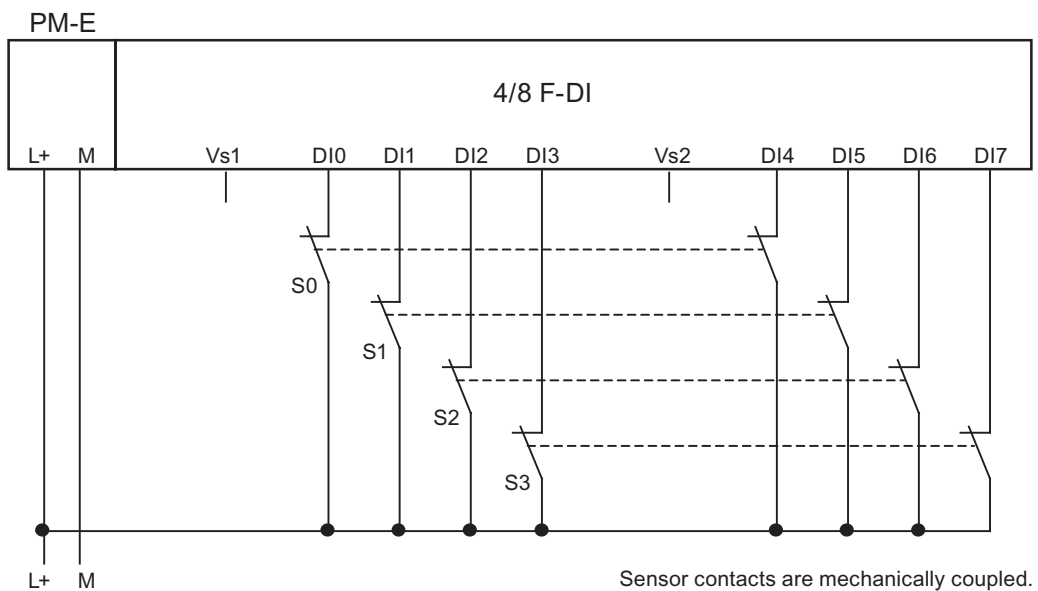

Figure 7-25 Wiring Diagram EM 4/8 F-DI DC24V PROFIsafe - Two channels of a 2-Channel Sensor Connected, External Sensor Power Supply

Wiring Diagram for Application 2.2 - Connecting Two One-channel Sensors to Two Channels

Two channels of two 1-channel sensors are connected to two inputs of the F-module for each process signal (1oo2 evaluation). The sensors can also be supplied via an external sensor supply.

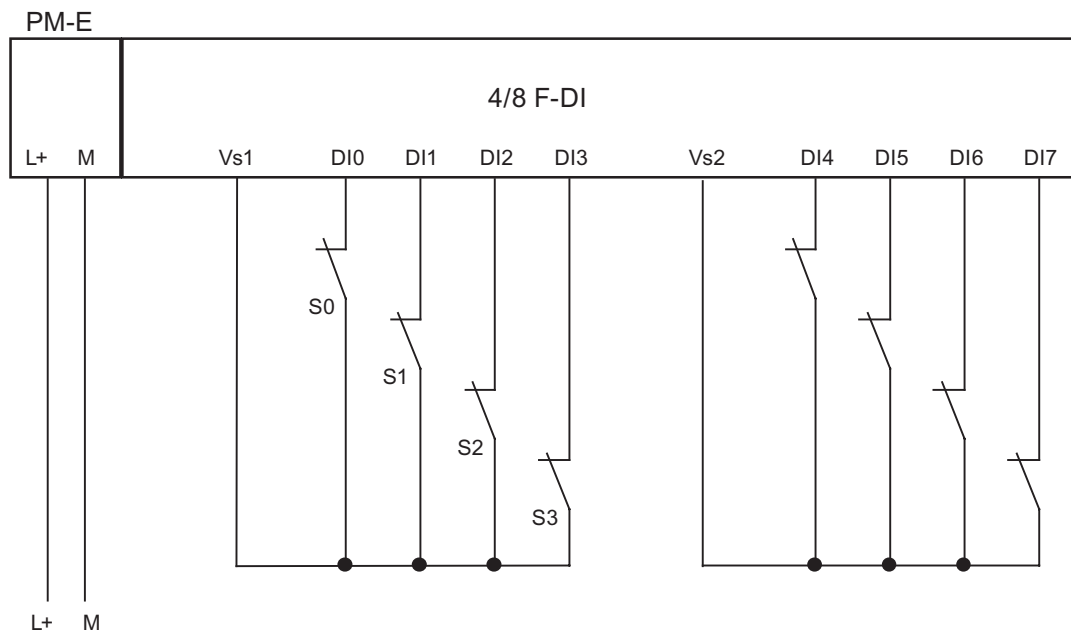

Figure 7-26 Wiring Diagram EM 4/8 F-DI DC24V - Two channels of Two 1-Channel Sensors Connected, Internal Sensor Power Supply



Warning

To achieve AK6/SIL3/Category 3 using this wiring, you must use a sensor qualified for this class.

Assignable Parameters for Use Case 2.2

Set the parameter "evaluation of sensors" to "1oo2 evaluation" and the parameter "type of sensor interconnection" to "2-channel equivalent" for the relevant input. Deactivate the parameter "short-circuit test."

Special Features of Fault Detection (Use Case 2.2)

The following table presents fault detection according to the sensor supply and the parameter assignment for the short-circuit test:

Table 7-23 EM 4/8 F-DI DC24V PROFIsafe: Fault Detection (Application 2.2)

Example of fault	Fault detection when ...	
	Internal Sensor Supply and Deactivated Short-Circuit Test	External Sensor Supply
Short circuit in DI 0 with DI 1	Yes*	Yes*
Short circuit in DI 0 with DI 4	No	No
Short circuit in DI 0 with DI 5	Yes*	Yes*
P-short circuit in DI 0	Yes*	Yes*
M-short circuit in DI 0	Yes*	Yes*
Discrepancy error	Yes	Yes
P-short current in sensor supply 1	No	No
M-short circuit in sensor supply 1, or sensor supply 2 defective	Yes	Yes
Short circuit in sensor supply 1 with sensor supply 2	No	No
Fault in read/test circuit	Yes	Yes
Supply voltage fault	Yes	Yes

*: Fault is detected only in case of signal corruption. In other words, the signal read differs from the sensor signal (discrepancy error). If there is no signal corruption with respect to the sensor signal, fault detection is not possible and is not required from a safety standpoint.

Wiring Diagram for Application 2.3 - Connecting a Non-equivalent Sensor to Two Non-equivalent Channels

Two channels of a non-equivalent sensor are connected nonequivalently to two inputs of the F-module for each process signal (1oo2 evaluation).

The left-hand channels on the F-module (DI0 through DI3) supply the useful signals. If no faults are detected, these signals will be available in the I/O area for inputs on the F-CPU.

Note

If the voltage is supplied to the sensor by the F-DI module, you must use the internal sensor supply Vs1. Connection to Vs2 is not possible.

The wiring is carried out on the appropriate terminal module.

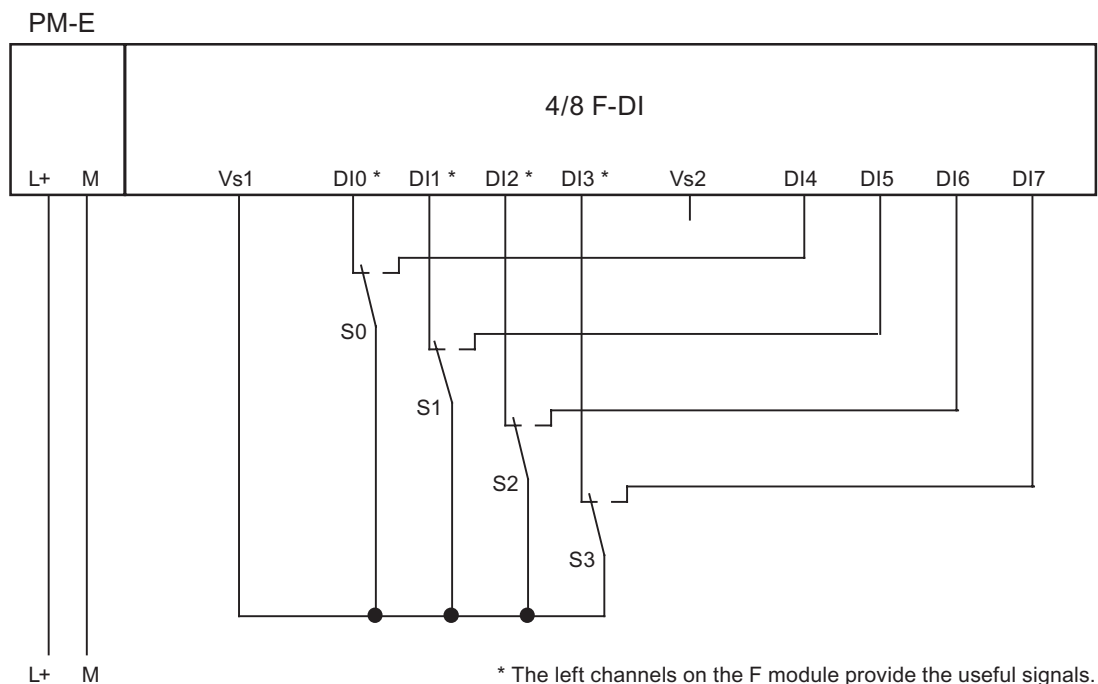

Figure 7-27 Wiring Diagram for EM 4/8 F-DI DC24V - One Nonequivalent Sensor Connected Nonequivalently via Two Channels, Internal Sensor Supply

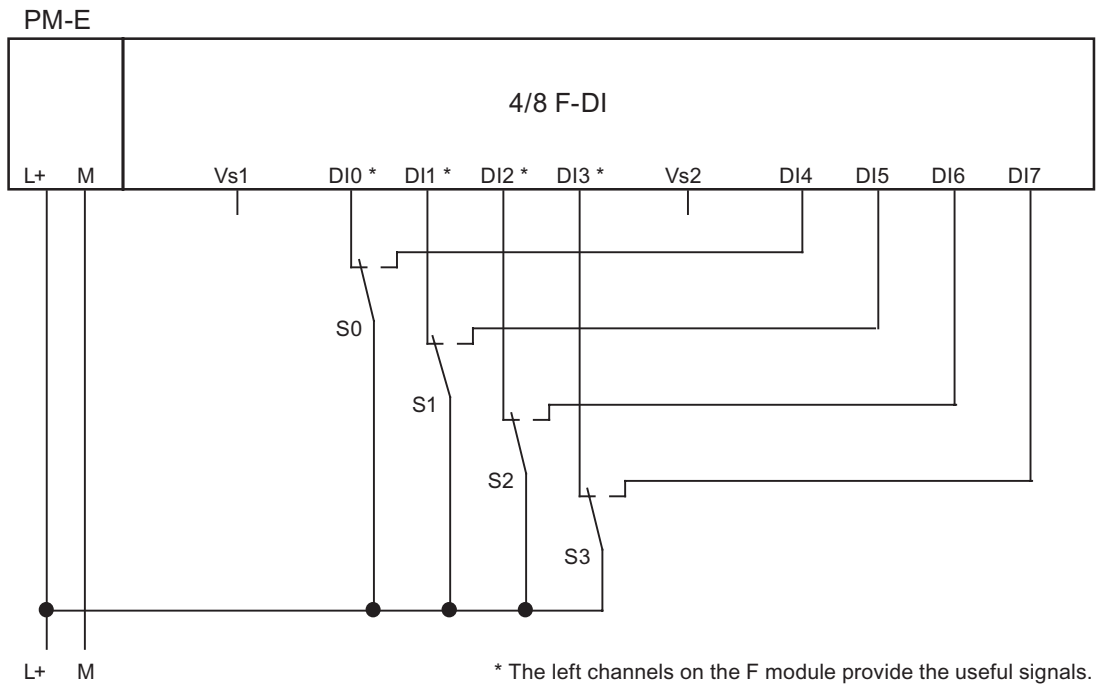

Figure 7-28 Wiring Diagram EM 4/8 F-DI DC24V - Two Channels of a Non-Equivalent Sensor Connected, External Sensor Power Supply

Wiring Diagram for Application 2.3 - Connecting Two One-channel Sensors to Two Non-equivalent Channels

Two channels of two 1-channel sensors are connected nonequivalently to two inputs of the F-I/O module for each process signal (1oo2 evaluation).

The left-hand channels on the F-module (DI0 through DI3) supply the useful signals. If no faults are detected, these signals will be available in the I/O area for inputs on the F-CPU.

The sensors can also be supplied via an external sensor supply.

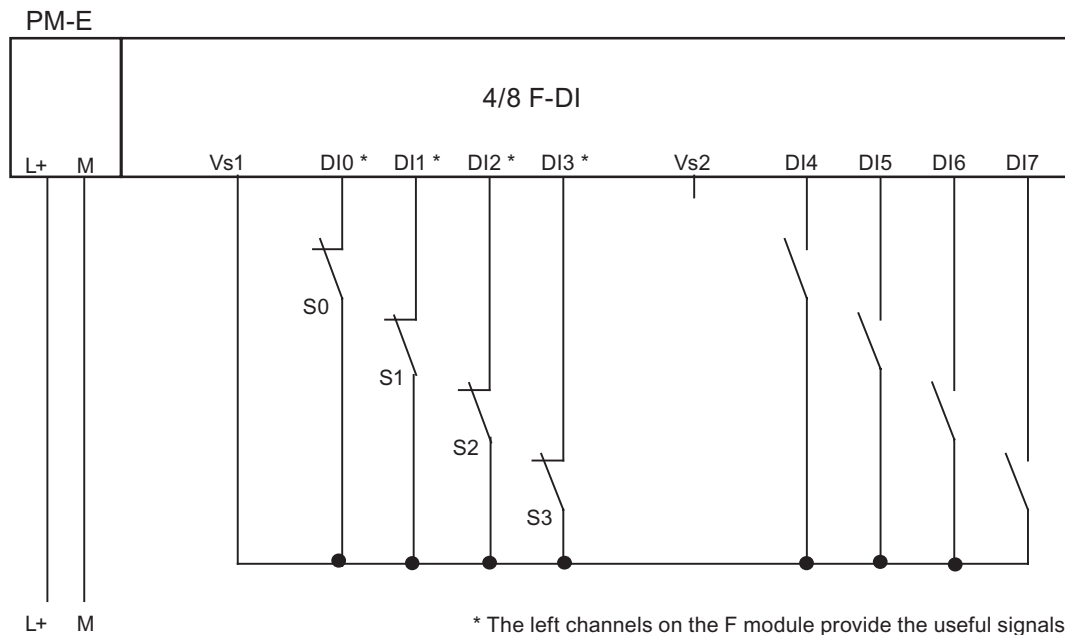

Figure 7-29 Wiring Diagram EM 4/8 F-DI DC24V - Two Channels of Two 1-Channel Sensors Connected Non-Equivalent, Internal Sensor Power Supply



Warning

To achieve AK6/SIL3/Category 3 using this wiring, you must use a sensor qualified for this class.

Assignable Parameters for Use Case 2.3

Set the parameter "evaluation of sensors" to "1oo2 evaluation" for the corresponding input and the parameter "type of sensor interconnection" to "2-channel nonequivalent". Deactivate the parameter "short-circuit test."

Special Features of Fault Detection (Use Case 2.3)

The following table presents fault detection according to the sensor supply and the parameter assignment for the short-circuit test:

Table 7-24 EM 4/8 F-DI DC24V PROFIsafe: Fault Detection (Application 2.3)

Example of fault	Fault detection when ...	
	Internal Sensor Supply and Deactivated Short-Circuit Test	External Sensor Supply
Short circuit in DI 0 with DI 1	Yes*	Yes*
Short circuit in DI 0 with DI 4	Yes	Yes
Short circuit in DI 0 with DI 5	Yes*	Yes*
P-short circuit in DI 0	Yes*	Yes*
M-short circuit in DI 0	Yes*	Yes*
Discrepancy error	Yes	Yes
P-short current in sensor supply 1	No	No
M-short circuit in sensor supply 1, or sensor supply 2 defective	Yes	Yes
Short circuit in sensor supply 1 with sensor supply 2	No	No
Fault in read/test circuit	Yes	Yes
Supply voltage fault	Yes	Yes

*: fault is detected only in case of signal corruption. In other words, the signal read differs from the sensor signal (discrepancy error). If there is no signal corruption with respect to the sensor signal, fault detection is not possible and is not required from a safety standpoint.

7.5.8 Application 3: Safety Mode AK6/SIL3/Category 4

Assigning Inputs to Each Other

The EM 4/8 F-DI DC24V PROFIsafe has 8 fail-safe inputs DI 0 to DI 7 (SIL2). A pair of these inputs can each be used as one input (SIL3). The following assignment applies:

- DI 0 with DI 4
- DI 1 with DI 5
- DI 2 with DI 6
- DI 3 with DI 7

Sensor Supply

The EM 4/8 F-DI 24 VDC PROFIsafe provides sensor supply Vs1 for inputs 0 to 3 and sensor supply Vs2 for inputs 4 to 7. The sensor must be supplied internally.

Wiring Diagram for Application 3.1 - Connecting a Two-channel Sensor to Two Channels

Two channels of a 2-channel sensor are connected to two inputs of the F-module for each process signal (1oo2 evaluation).

The wiring is carried out on the appropriate terminal module.

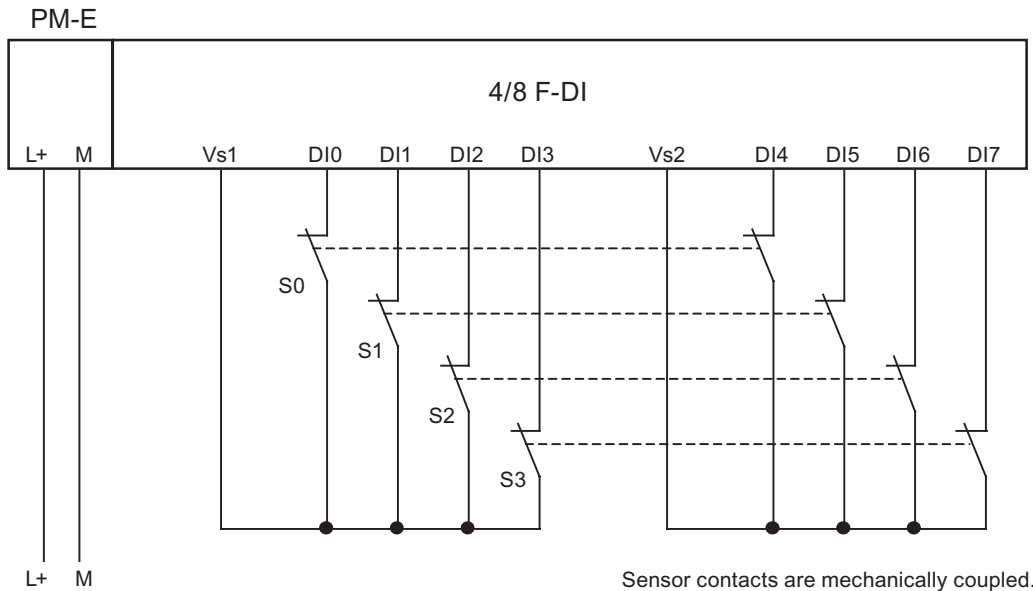

Figure 7-30 Wiring Diagram EM 4/8 F-DI DC24V PROFIsafe - Two Channels of a 2-Channel Sensor Connected, Internal Sensor Power Supply

Alternatively two channels of two single-channel sensors can be connected (see figure *EM 4/8 F-DI DC24V wiring diagram - two channels of two single-channel sensors connected, internal power supply*). In this case, the same process variable is acquired with two mechanically separate sensors.



Warning

To achieve AK6/SIL3/Category 4 using this wiring, you must use a sensor qualified for this class.

Assignable Parameters for Use Case 3.1

Set the parameter "evaluation of sensors" to "1oo2 evaluation" and the parameter "type of sensor interconnection" to "2-channel equivalent" for the relevant input. Activate the "short circuit test" parameter.

Wiring Diagram for Application 3.2 - Connecting a Non-equivalent Sensor to Two Non-equivalent Channels

Four process signals can be connected to an EM 4/8 F-DI 24 VDC PROFIsafe. Two channels of a sensor are connected nonequivalently to two inputs of the F-module for each process signal (1oo2 evaluation).

The left-hand channels on the F-module (DI0 through DI3) supply the useful signals. If no faults are detected, these signals will be available in the I/O area for inputs on the F-CPU.

Note

You must use the internal sensor supply Vs1 to supply voltage to the sensor. Connection to Vs2 is not possible.

The wiring is carried out on the appropriate terminal module.

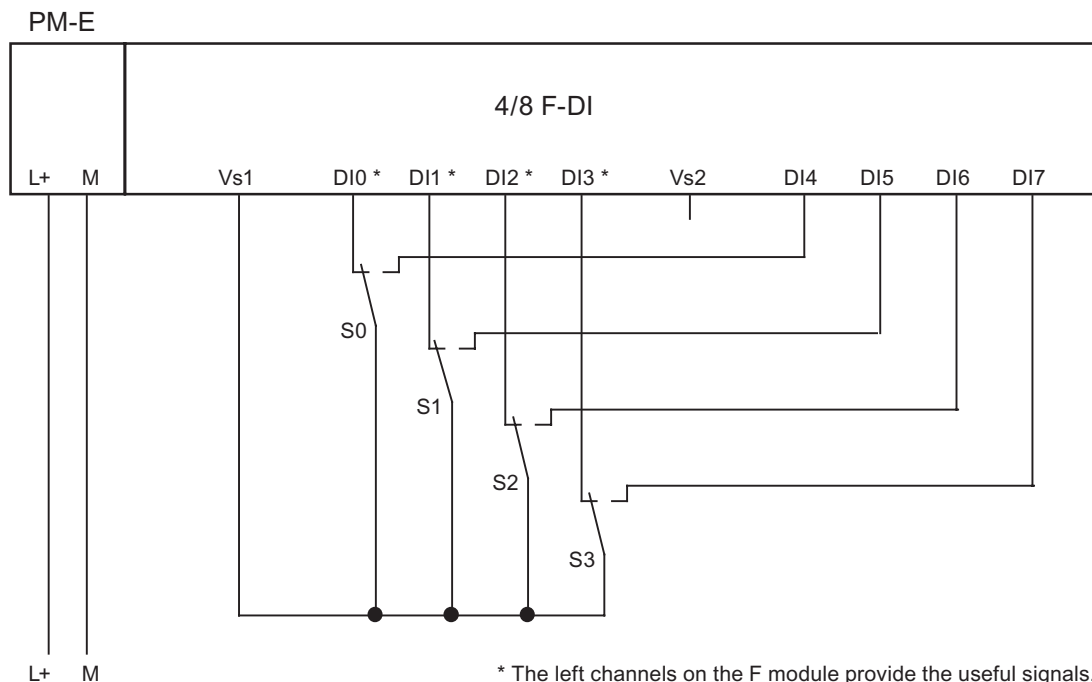

Figure 7-31 Wiring Diagram for EM 4/8 F-DI DC24V - One Nonequivalent Sensor Connected Nonequivalently via Two Channels, Internal Sensor Supply



Warning

To achieve AK6/SIL3/Category 4 using this wiring, you must use a sensor qualified for this class.

Wiring Diagram for Application 3.2 - Connecting Two One-Channel Sensors Nonequivalently via Two Channels

Two channels of two 1-channel sensors are connected nonequivalently to two inputs of the F-I/O module for each process signal (1oo2 evaluation).

The left-hand channels on the F-module (DI0 through DI3) supply the wanted signals. If no faults are detected, these signals will be available in the I/O area for inputs on the F-CPU.

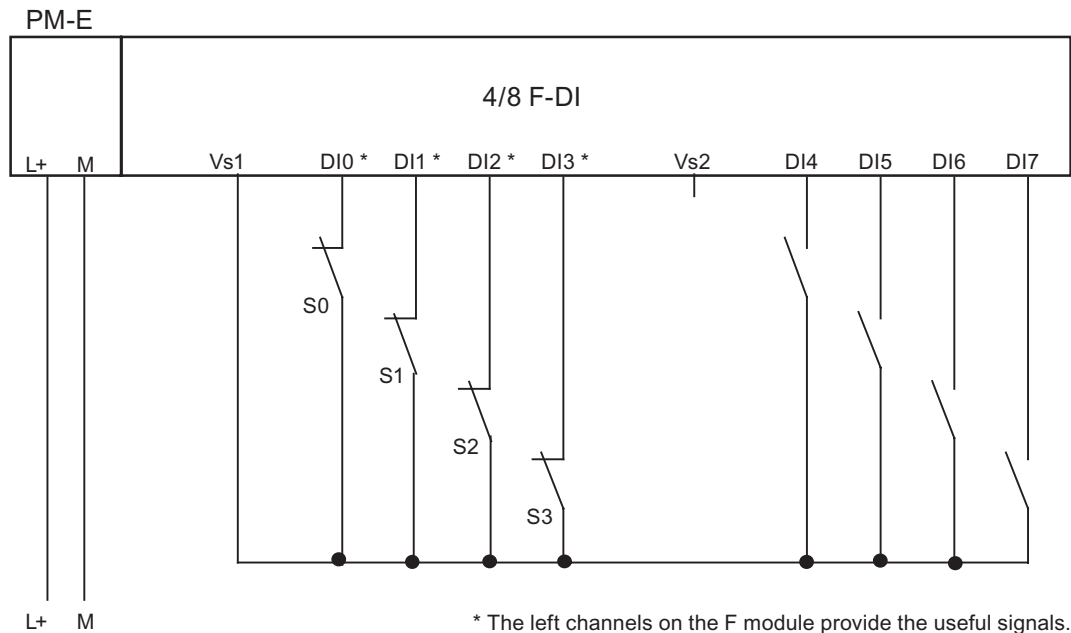

Figure 7-32 Wiring Diagram for EM 4/8 F-DI DC24V - Two One-Channel Sensors Connected Nonequivalently via Two Channels, Internal Sensor Supply



Warning

To achieve AK6/SIL3/Category 4 using this wiring, you must use a sensor qualified for this class.

Assignable Parameters for Use Case 3.2

Set the parameter "evaluation of sensors" to "1oo2 evaluation" for the corresponding input and the parameter "type of sensor interconnection" to "2-channel nonequivalent". Activate the "short circuit test" parameter.

Special Features of Fault Detection (Use Case 3.1 and 3.2)

The following table presents fault detection according to the sensor supply and the parameter assignment for the short-circuit test:

Table 7-25 EM 4/8 F-DI DC24V PROFIsafe: Fault detection (use cases 3.1 and 3.2)

Example of fault	Fault detection with internal sensor power supply and activated short-circuit test for...	
	Sensor 2-channel equivalent	Sensor 2-channel non-equivalent
Short circuit in DI 0 with DI 1	Yes*	Yes*
Short circuit in DI 0 with DI 4	Yes*	Yes
Short circuit in DI 0 with DI 5	Yes*	Yes*
P-short circuit in DI 0	Yes	Yes
M-short circuit in DI 0	Yes*	Yes*
Discrepancy error	Yes	Yes
P-short current in sensor supply 1	Yes	Yes
M-short circuit in sensor supply 1, or sensor supply 2 defective	Yes	Yes
Short circuit in sensor supply 1 with sensor supply 2	Yes	Yes
Fault in read/test circuit	Yes	Yes
Supply voltage fault	Yes	Yes
*: Fault is detected only in case of signal corruption. In other words, the signal read differs from the sensor signal (discrepancy error). If there is no signal corruption with respect to the sensor signal, fault detection is not possible and is not required from a safety standpoint.		

Requirements for Machine Protection Applications with Category 4

The following requirements apply for applications in machine protection with category 4:

- The wiring between sensors and automation system and between automation system and actuators must be designed to the state-of-the-art engineering and standards to prevent short circuit and
- that all short circuits listed in the above table are covered. It is sufficient to locate a short circuit, because two faults are required for it to occur (both signal lines in short circuit have an insulation fault). A multiple short circuit analysis is not required.

Procedures for locating all short circuits are therefore permissible if single short circuits are not located,

- cause corruption of read signals compared to the sensor signals or
- cause corruption of read signals compared to sensor signals in the direction that ensures safety.

7.5.9 Diagnostic Functions of the EM 4/8 F-DI 24 VDC PROFIsafe

Behavior in Case of Supply Voltage Failure

Failure of the Vs1 and Vs2 sensor power supply of the EM 4/8 F-DI DC24V PROFIsafe is indicated by the 1VsF and 2VsF LED on the F-module. This information is also provided in the module (diagnostic entry). Either all channels of the module are passivated or, in case of channel-level passivation, the relevant channels are passivated.

Diagnostic Functions

The following table presents an overview of the diagnostic functions of the EM 4/8 F-DI 24 VDC PROFIsafe. The diagnostic functions are assigned either to one channel or to the entire module.

Table 7-26 Diagnostic Functions of the EM 4/8 F-DI 24 VDC PROFIsafe

Diagnostic Function*	Fault Number	LED	Signaled in Application	Effective Range of Diagnostic	Assign-able
Short circuit	1 _H	SF	1, 2, 3	Channel	Yes
Overtemperature	5 _H	SF	1, 2, 3	Module	No
Internal fault	9 _H	SF	1, 2, 3	Module	No
Parameter assignment error	10 _H	SF	1, 2, 3	Module	No
Missing external auxiliary supply	11 _H	1VsF 2VsF	1, 2, 3	Module	No
Communication error	13 _H	SF	1, 2, 3	Module	No
Discrepancy error (1oo2 evaluation)	19 _H	SF	2,3	Channel	No

*: Specially for F-modules; display in *STEP 7*, see "Channel-Specific Diagnostics, Fault Types of Fail-Safe Modules" table

Note

If you have activated the **short-circuit test** for the F-DI module in *STEP 7* and are using only one of the two internal sensor supplies of the module (Vs1 or Vs2), a channel M-short circuit is then detected for each of the four channels with a sensor supply that is not used. Four "short-circuit" diagnostic functions are generated in the diagnostic buffer of the F-module.

Special Features of Fault Detection

Detection of some faults (such as short circuits or discrepancy errors) is dependent on the application, the wiring, and the parameter assignment of the short-circuit test. For this reason, tables on fault detection for the use cases are presented in *Use Case 1: Safety Mode AK4/SIL2/Category 3* to *Use Case 3: Safety Mode AK6/SIL3/Category 4*.

Causes of Faults and Corrective Measures

The following table presents the possible causes of faults and corrective measures for the individual diagnostic messages of the EM 4/8 F-DI DC24V PROFIsafe.

Table 7-27 Diagnostic Messages of the EM 4/8 F-DI DC24V PROFIsafe, Causes of Faults and Corrective Measures

Diagnostic Message	Possible Causes	Corrective Measures
Short circuit	Short circuit in the sensor	Eliminate short circuit/cross circuit
	Cross circuit in the sensor	
	Internal fault	Replace module
Over-temperature	Shutdown due to violation of upper or lower temperature limit value in the module case.	Check ambient temperature, Check whether permissible output current of the sensor power supply is exceeded at the ambient temperature After correction of the fault the module must be removed and inserted or switched off and on
Internal fault	Internal module fault has occurred	Replace module
Parameter assignment error	Inserted module does not match configuration Faulty parameter assignment	Correction of configuration (compare actual and setpoint), Check communication paths Correction of configuration
	PROFIsafe address set incorrectly in the F-module	Check whether the PROFIsafe address on the module matches the configuration in <i>STEP 7 HW Config</i>
Missing external auxiliary supply	No supply voltage or supply voltage is too low	Check interconnected power module Check module for correct contact After correction of the fault the module must be removed and inserted or switched off and on
Communication error	Error in communication between F-CPU and module due to defective PROFIBUS connection or higher than permissible EMI, for example	Check the PROFIBUS connection Eliminate the interference.
	PROFIsafe monitoring time set too low	Set a higher value for the "F monitoring time" parameter for the module in <i>STEP 7 HW Config</i>
	Configuration of the F-module does not match fail-safe program	Generate safety program again; then download configuration and safety program to F-CPU again

Diagnostic Message	Possible Causes	Corrective Measures
Discrepancy error (1oo2 evaluation)	Faulty process signal Defective sensor	Check process signal, replace sensor if necessary
	Short circuit between unconnected sensor cable and the sensor supply cable	Eliminate short circuit
	Wire break in connected sensor cable or the sensor supply cable	Eliminate broken wire
	Assigned discrepancy time too short	Check the assigned discrepancy time
		Once the fault is eliminated, the F-module must be reintegrated in the safety program.

For more detailed information on passivation and reintegration of F-I/O, refer to "Diagnostics" and the *S7 Distributed Safety, Configuration and Programming* or *Programmable Controllers S7 F/FH* manuals.

Generally Applicable Information on Diagnostics

For information in diagnostics that affects all fail-safe modules (such as readout of diagnostic functions; passivation of channels) see this manual in "Diagnostics" and the *S7 Distributed Safety, Configuration and Programming* manual or *Programmable Controllers S7 F/FH*.

See also

Fault Diagnostics (Page 5-3)

7.5.10 Technical Specifications for the EM 4/8 F-DI 24 VDC PROFIsafe

Overview

Technical Specifications		
Dimensions and Weight		
Dimensions W x H x D (mm)	30 x 81 x 52	
Weight	Approx. 78 g	
Data for Specific Module		
Number of inputs		
• 1-channel	8, maximum	
• 2-channel	4, maximum	
Assigned address area		
• I/O area for inputs	6 Byte	
• I/O area for outputs	4 Byte	
Length of cable		
• Unshielded *	max. 200 m (at input delay 3 ms * and 15 ms)	
• Shielded *	max. 200 m (at input delay 0.5 ms, 3 ms and 15 ms)	
Maximum achievable safety class	1-channel	2-channel
• In accordance with IEC 61508	SIL2	SIL3
• In accordance with DIN VDE 0801	AK4	AK6
• In accordance with EN 954	Category 3	Category 4
Fail-safe performance characteristics	SIL2	SIL3
• Low demand mode (average probability of failure on demand)	< 1,00E-03	< 1,00E-05
• High demand/continuous mode (probability of a dangerous failure per hour)	< 1,00E-08	< 1,00E-05
Voltages, Currents, Potentials		
Rated supply voltage L+	24 VDC	
• Permissible range	20.4 V to 28.8 V	
• Power loss ride-through of L+	None	
• Power loss ride-through of internal P5	5 ms	
• Reverse polarity protection	No	
Number of simultaneously controllable inputs		
• Horizontal installation		
– Up to 55°C	8 (with 28.8 V)	
– Up to 60°C	8 (with 24 V)	
– Up to 60°C	6 (with 28.8 V)	
• Vertical installation		
– Up to 40°C	8	

Technical Specifications	
Electrical isolation	
• Between channels and backplane bus	Yes
• Between channels and power supply	No
• Between channels	No
• Between channels/power supply and shield	Yes
Permissible potential difference between	
• Shield and ET 200S bus connection	75 VDC/60 VAC
• Shield and I/O (DIs, P1/P2 buses)	75 VDC/60 VAC
• ET 200S bus connection and I/O (DIs, P1/P2 buses)	250 VAC
Isolation in the series tested with	
• Shield and ET 200S bus connection	500 VDC/1 min or 600 VDC/1 s
• Shield and I/O (DIs, P1/P2 buses)	500 VDC/1 min or 600 VDC/1 s
• ET 200S bus connection and I/O (DIs, P1/P2 buses)	1500 VAC/1 min or 2545 VDC/1 s
Isolation in the type test tested with	
• Shield and ET 200S bus connection	350 VAC/1 min
• Shield and I/O (DIs, P1/P2 buses)	350 VAC/1 min
• ET 200S bus connection and I/O (DIs, P1/P2 buses)	2830 VAC/1 min
• Impulse current test between ET 200S bus connection and I/O (DIs, P1/P2 buses)	6000 VDC/5 positive and 5 negative pulses
Current consumption	
• From backplane bus	28 mA, typical
• From load voltage L+ (without load)	120 mA, typical
Power dissipation of the module	4 W, typical
Status, Interrupts, Diagnostics	
Status display	
Inputs	Green LED per channel
Sensor supply	Red LED per channel
Diagnostic Functions	
• Group fault display	Red LED (SF)
• Diagnostic information can be displayed	Possible
Sensor Supply Outputs	
Number of outputs	2
Output voltage	
• Loaded	Minimum L+ (-1.5 V)
Output current	
• Rated value	300 mA
• Permissible range	0 mA to 300 mA
Permissible aggregate current of outputs	600 mA
Short-circuit protection	Yes, electronic
• Operating value	0.7 A to 1.8 A

Technical Specifications		
Data for Selecting a Sensor**		
Input voltage		
• Rated value	24 VDC	
• For "1" signal	15 V to 30 V	
• For "0" signal	-30 V to 5 V	
Input current		
• For "1" signal	3.7 mA, typical	
Input delay*	Assignable (for all inputs together)	
• For "0" after "1"	Typically 0.5 ms	(0.3 ms to 0.7 ms)
	Typically 3 ms	(2.6 ms to 3.4 ms)
	Typically 15 ms	(13 ms to 17 ms)
• For "1" after "0"	Typically 0.5 ms	(0.3 ms to 0.7 ms)
	Typically 3 ms	(2.6 ms to 3.4 ms)
	Typically 15 ms	(13 ms to 17 ms)
Input characteristic	In accordance with IEC 1131, Type 1	
Connection of 2-wire proximity switch	Not possible	
• Permissible quiescent current	0.6 mA, maximum	
Time, Frequency		
Internal preparation times	See <i>Response Times</i>	
Acknowledgment time in safety mode		
• Short-circuit test activated	min. 4 ms / max. 7 ms min. 4 ms / max. 12 ms min. 4 ms / max. 9 ms	
• Short-circuit test deactivated	4 ms minimum/6 ms maximum	
Minimum sensor signal duration	See <i>Table "Minimum Duration of Sensor Signals for Correct Recording by F-DI Module"</i> in <i>"Wiring and Installing Modules"</i>	
Protection against Overvoltage		
Protection of power supply L+ from surge in accordance with IEC 61000-4-5 with external protection elements only		
• Symmetrical (L+ to M)	+ 1 kV; 1,2/50 μ s	
• Asymmetrical (L+ to PE, M to PE)	+2 kV; 1,2/50 μ s	
Protection of outputs from surge in accordance with IEC 61000-4-5 with external protection elements only		
• Symmetrical (Vs, DI to M)	+1 kV; 1,2/50 μ s	
• Asymmetrical (Vs, DI to PE, M to PE)	+1 kV; 1,2/50 μ s	
<p>*: With an input delay of 0.5 ms, shielded cable must be used for the digital inputs and the sensor supply. With 3 ms input delay shielded cables must be used if there is a danger of overvoltage on the signal lines (see "Electromagnetic Compatibility") to prevent possible passivation of the fail-safe digital inputs and the sensor power supply switching off. If unshielded signal lines are used the safe behavior of the process quantities is ensured.</p> <p>**.: For more information on the requirements for sensors and actuators, see "Wiring and Installing Modules."</p>		

7.6 4 F-DO DC24V/2A PROFIsafe digital electronic module

7.6.1 Properties of the 4 F-DO DC24V/2A PROFIsafe digital electronic module

Order Number

6ES7 138-4FB02-0AB0

Properties

The 4 F-DO 24 VDC/2 A PROFIsafe digital electronic module has the following properties:

- Four outputs, P/M switching
- 2 A output current
- 24 VDC rated load voltage
- Suitable for solenoid valves, DC contactors, and indicator lights
- Group fault display (SF; red LED)
- Status display for each output (green LED)
- Assignable diagnostics
- Safety class SIL3 achievable

Power Modules for SIL2 or SIL3

Table 7-28 EM 4 F-DO DC24V/2A PROFIsafe: Power Modules for AK/SIL/Category

Power module	Achievable AK/SIL/Category
Supply using PM-E 24 VDC	AK4/ SIL2/ Category 3
Supply using PM-E 24 VDC/120/230 VAC	AK6/ SIL3/Category 4
Power supply by PM-E DC24..48V	AK6/ SIL3/Category 4

Switching loads that are grounded

If the EM 4 F-DO DC24V/2A PROFIsafe switches loads that have a connection between chassis and ground (for example to improve the EMC properties) **and** if chassis and ground are connected in the power supply being used, a "short circuit" will be detected.

From the perspective of the F-module, the M switch is bridged by the chassis-ground connection (refer to the following figure as an example of a EM 4 F-DO DC24V/2A PROFIsafe).

Remedy:

- Use the PM-E F pp DC24V PROFIsafe
- The value of the resistance between chassis and ground at the load end must be greater than 100 k Ω

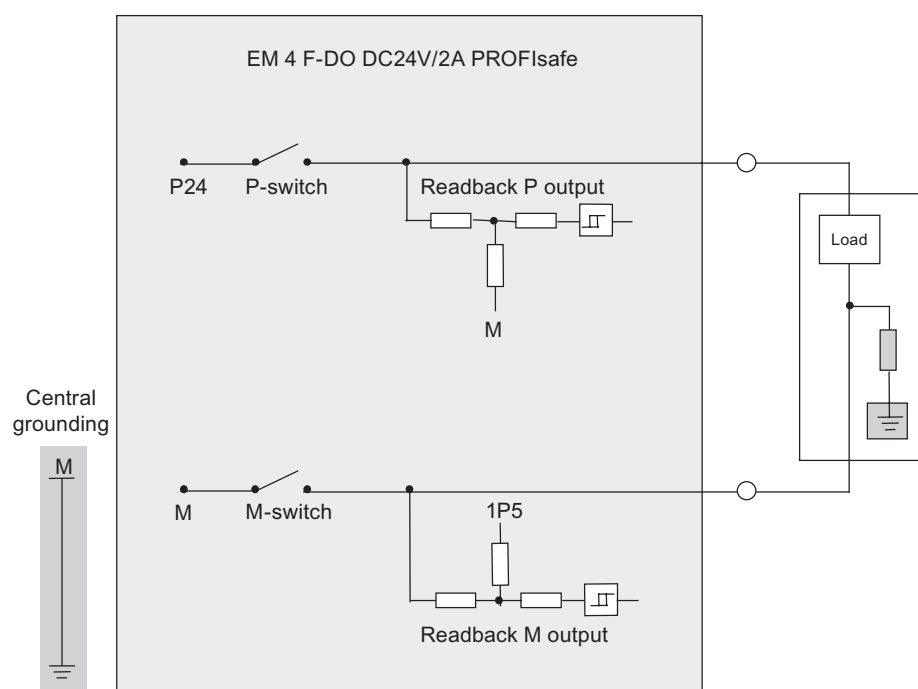

Figure 7-33 Connecting Grounded Loads (resistance exists between chassis and ground)

Capacitive Crosstalk of Digital Input/Output Signals

See *Properties of the PM-E F pm DC24V PROFIsafe Power Module*

7.6.2 Terminal assignment for EM 4 F-DO DC24V/2A PROFIsafe

Front View

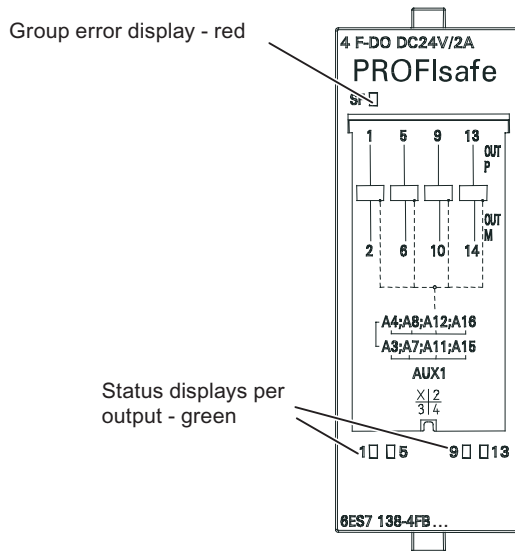

Figure 7-34 Front view EM 4 F-DO DC24V/2A PROFIsafe



Warning

The SF LED and the status displays of the outputs must not be evaluated for safety-related activities.

Terminal assignment

The terminal assignment of the EM 4 F-DO 24 VDC/2 A PROFIsafe for the applicable terminal modules TM-E30S44-01, TM-E30C44-01, TM-E30S46-A1, and TM-E30C46-A1 is shown in the following figure.

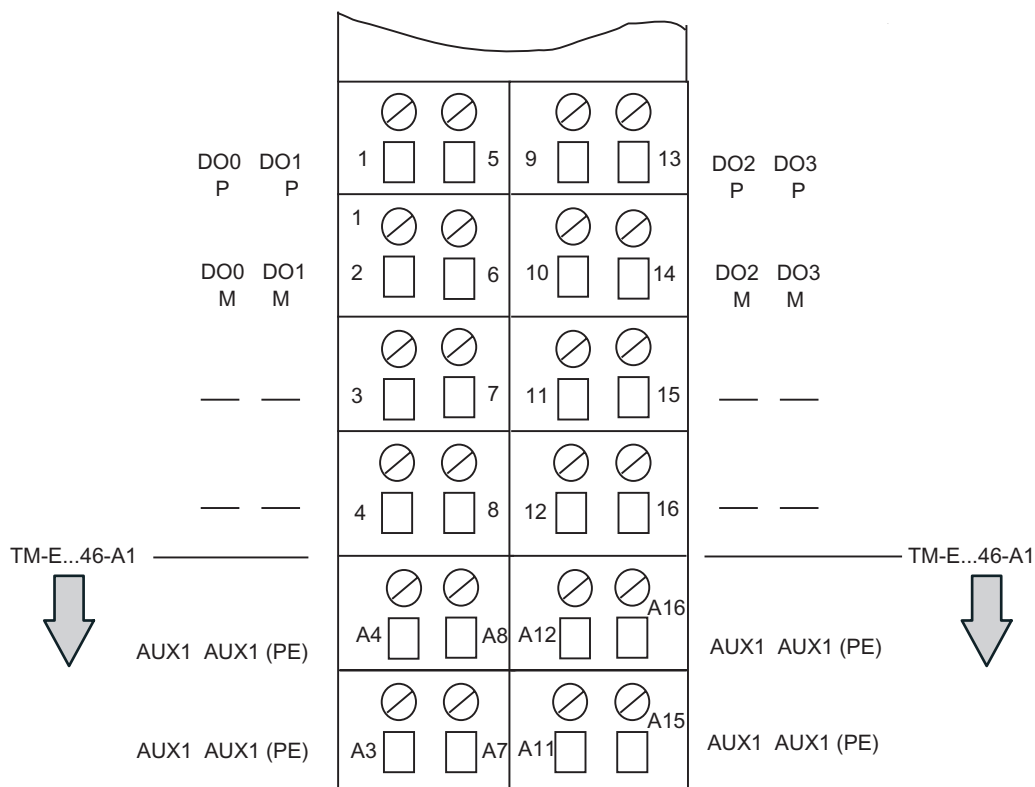

Figure 7-35 Terminal Assignment TM-E...44-01/TM-E...46-A1 for EM 4 F-DO DC24V/2A PROFIsafe

Dox P: Terminals for fail-safe digital output 0 (P/M switching)

Dox M: Terminals for fail-safe digital output 0 (P/M switching)

at TM-E...46-A1: AUX 1 bus implemented. Connection to terminals A3 to A16 for any connection of PE (individual grouping of load current power supplies possible)

See also

Properties of the PM-E F pm DC24V PROFIsafe Power Module (Page 7-2)

7.6.3 Wiring diagram of the EM 4 F-DO DC24V/2A PROFIsafe

Block Diagram

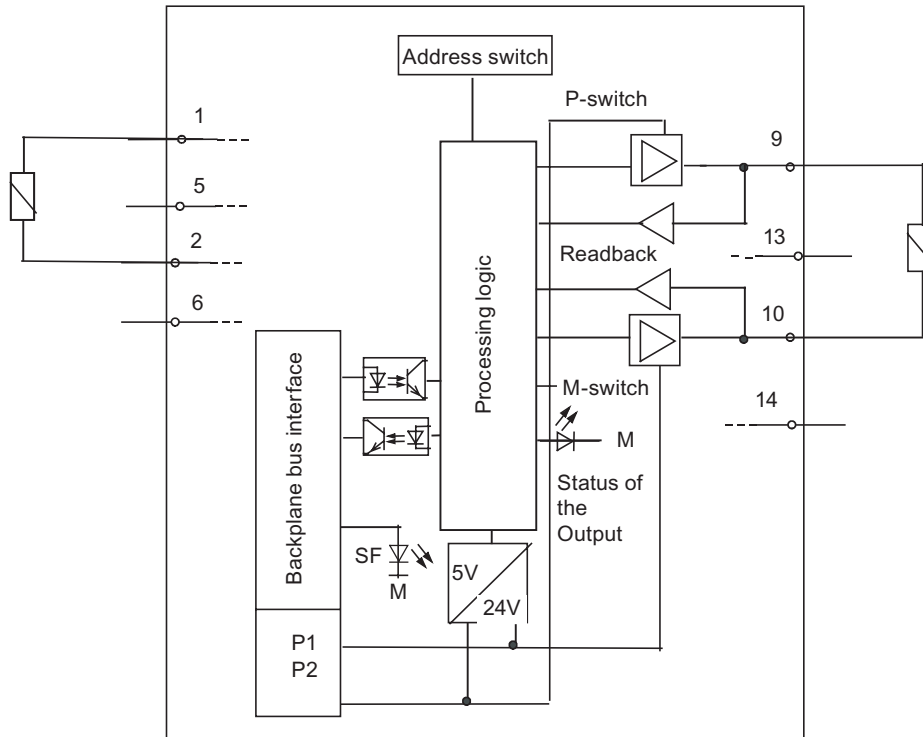

Figure 7-36 Block Diagram of the EM 4 F-DO DC24V/2A PROFIsafe

Wiring Diagram

Each of the four fail-safe digital outputs consists of a DOx P P-switch and a DOx M M-switch. They connect the load between P and M-switches. The two switches are always controlled so that voltage is applied to the load.

The wiring is carried out on an appropriate terminal module.

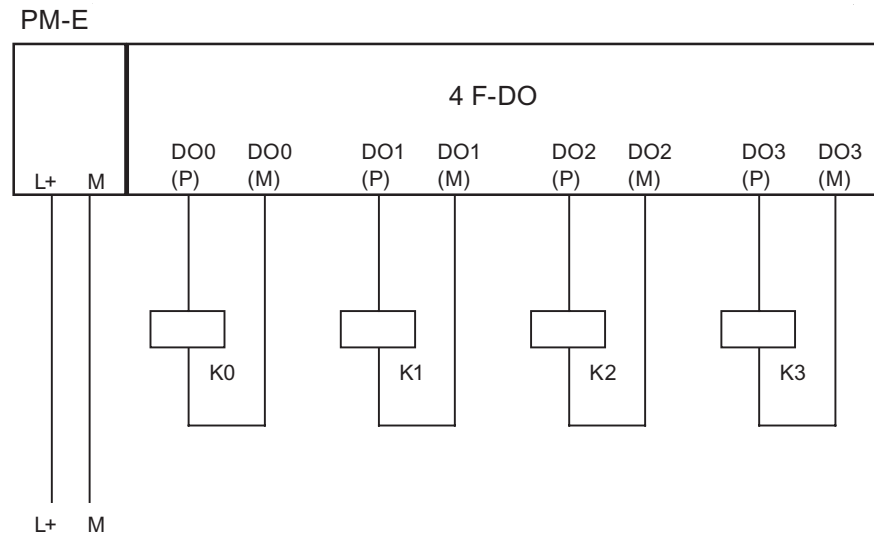

Figure 7-37 Wiring diagram of the EM 4 F-DO DC24V/2A PROFIsafe

Connection of Two Relays on One Digital Output

You can connect two relays using one fail-safe digital output. The following conditions should be kept in mind:

- L+ and M of the relays must be connected with L+ and M of the PM-E F (reference potential must be equal).
- The normally open contacts of the two relays must be connected in series.

A connection to each of the four digital outputs is possible. The following figure shows the example of the connection at DO 0. This circuit achieves AK6/SIL3/Category 4.

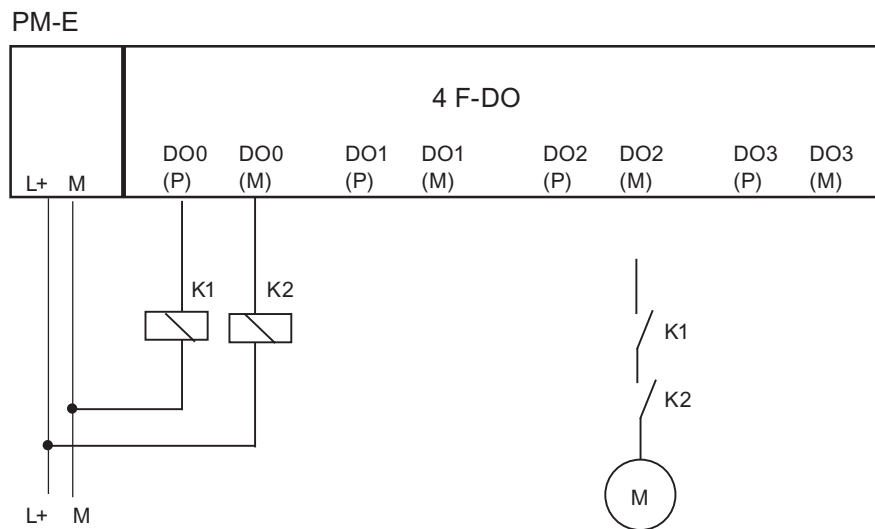

Figure 7-38 Wiring diagram per two relays on 1 F-DO of the EM 4 F-DO DC24V/2A PROFIsafe



Warning

When connecting two relays on one digital output, (as shown in the figure above), the errors "wire break" and "overload" are detected only at the P-switch (not at the M-switch).



Warning

The controlled actuator can no longer be switched off when there is a cross circuit between the P and M-switches of the output. To avoid cross circuits between P and M-switches of a fail-safe digital output, you should connect the relay on the between P and M-switches to protect against cross circuits (for example with cables separately sheathed or in a separate cable duct).

Note

The EM 4 F-DO DC24V/2A PROFIsafe performs a bit pattern test approximately every 15 minutes. The module generates a max. 4 ms pulse for this. This test is performed time staggered between the P and M switch, so that the actuator is not activated. However, the pulse may be picked up by respective relay, which can result in a reduced service life for the relay.

We therefore recommend the wiring scheme described in the following.

Avoiding/Dealing with Cross Circuits

To protect against cross circuits between P and M-switches of a fail-safe digital output, we recommend the following wiring schemes:

PM-E

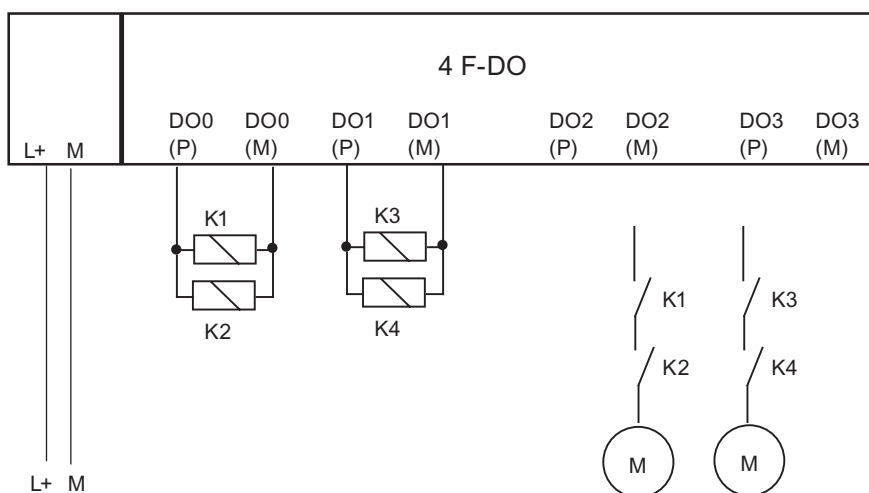

Figure 7-39 Wiring diagram per two relays parallel on 1 F-DO of the EM 4 F-DO DC24V/2A PROFIsafe

Note

With a parallel connection of two relays on one digital output (as shown above) the "wire break" fault is only detected if the wire break disconnected both relays from P or M. This diagnosis is not safety-relevant.

7.6.4 Parameters for the EM 4 F-DO DC24V/2A PROFIsafe

Parameters in STEP 7

The following table shows the parameters that can be set for the F-DO module (see also *Section 4*).

Table 7-29 Parameters of the F-DO module

Parameter	Range	Default	Type of Parameter	Effective range
F Parameter:				
F_destination_address	1 to 1022	Assigned by STEP 7	Static	Module
F monitoring time	10 to 10000 ms	150 ms	Static	Module
Module Parameters:				
Behavior after channel faults*	Passivate the entire module/Passivate the channel	Passivate the entire module	Static	Module
Channel fault	Activated/deactivated	Activated	Static	Channel
Readback Time	1 to 400 ms	1 ms	Static	Channel
Diagnostics: Wire break	Activated/deactivated	Deactivated	Static	Channel
* This setting is only relevant when S7 Distributed Safety V5.4 or higher is installed.				

Readback Time Parameter

Each output channel has its own selectable readback time. This time specifies the maximum duration of the turn off test for the corresponding channel and therefore also the readback time for turning off the channel.

The following readback times can be set: 1 ms, 5 ms, 10 ms, 50 ms, 100 ms, 200 ms and 400 ms.

You should set an adequately high readback time if the channel involved switches high capacitive loads. If the readback time for a controlled capacitive load is set too low, the output channel is passivated because the discharge of the capacitance does not take place within the turn off test.

If the readback signals are incorrect, the "short circuit" fault causes passivation of the output channel after the readback time elapses.

Connecting capacitive loads

If the electronic outputs of the EM 4 F-DO DC24V/2A PROFIsafe are connected to loads that require little current and have capacitance, this can lead to the "short circuit" error message. This is required because the capacitance cannot be sufficiently discharged during the set self-test readback time.

The following figure shows the typical curves of the selectable readback times indicating the relationship between load resistance and connectable load capacitance.

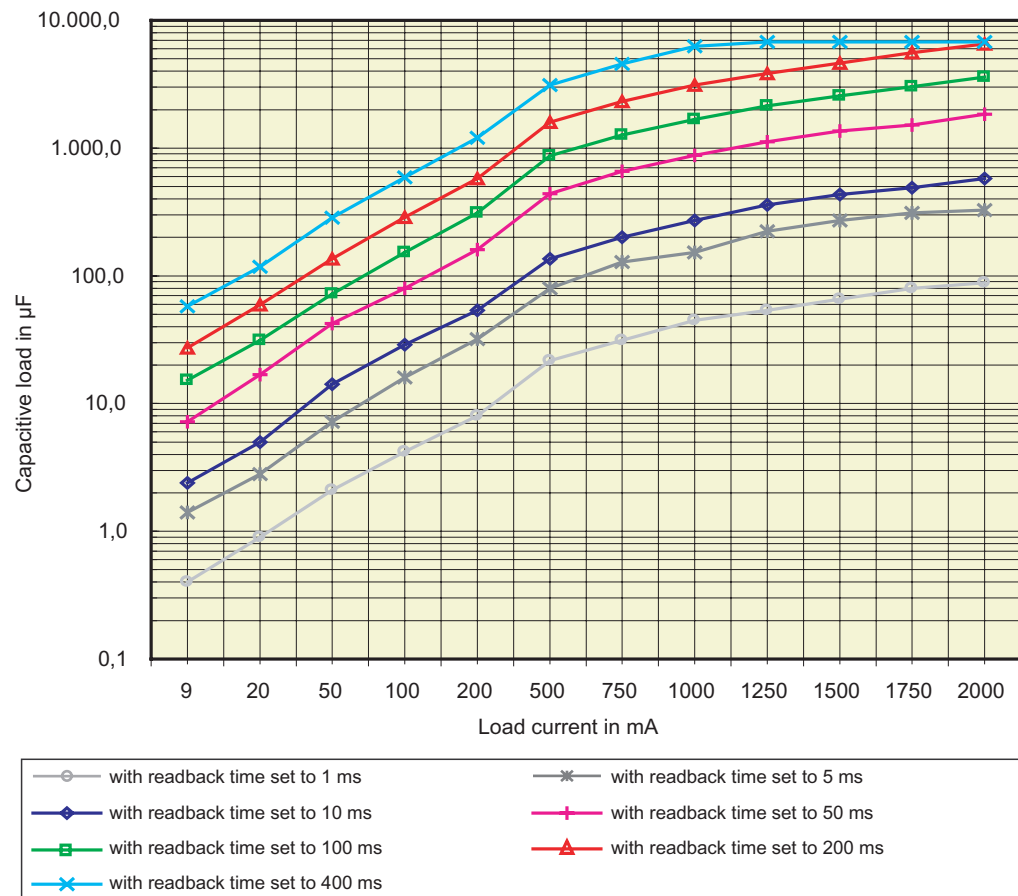

Figure 7-40 Relationship between Load Resistance and Switchable Load Capacitance for EM 4 F-DO DC24V/2A PROFIsafe

Remedy:

1. Determine the load current and capacitance of the load.
2. Determine the operating point in the figure above.
3. If the operating point is above the curve, you must increase the load current until the new operating point is below the curve by connecting a resistor in parallel.

7.6.5 Diagnostic Functions of the EM 4 F-DO 24 VDC/2 A PROFIsafe

Diagnostic Functions

The following table presents an overview of the diagnostic functions of the EM 4 F-DO 24 VDC/2 A PROFIsafe. The diagnostic functions are assigned either to one channel or to the entire module.

Table 7-30 Diagnostic Functions of the EM 4 F-DO 24 VDC/2 A PROFIsafe

Diagnostic Function*	Fault number	LED	Effective Range of Diagnostic	can be activated by user
Short circuit	1 _H	SF	Channel	No
Overload	4 _H	SF	Channel	No
Overtemperature	5 _H	SF	Module	No
Wire break	6 _H	SF	Channel	Yes
Internal error	9 _H	SF	Module	No
Parameter assignment error	10 _H	SF	Module	No
Missing external auxiliary supply	11 _H	SF	Module	No
Communication error	13 _H	SF	Module	No
Safety-related shutdown	19 _H	SF	Channel	No
*: specially for F-modules; display in <i>STEP 7</i> , see Table "Channel-Specific Diagnostics, Fault Types of Fail-Safe Modules"				

Causes of Errors and Corrective Measures

The following table shows the possible causes of errors and corrective actions for the various diagnostic messages of the EM 4 F-DO DC24V/2A PROFIsafe.

Table 7-31 Diagnostic Messages of the EM 4 F-DO DC24V/2A PROFIsafe, Causes of Errors and Corrective Measures

Diagnostic Message	Fault Detection	Possible Causes	Corrective Measures
Short circuit	Always	Short circuit in the actuator	Eliminate short circuit/cross circuit After correction of the fault the module must be removed and inserted or switched off and on
		Cross-circuit in the actuator	
		Internal error	Replace module
Overload	For "1" output signal only	Output stage is overloaded and becomes too hot	Eliminate overload
Overtemperature	Always	Shutdown due to violation of upper or lower temperature limit value in the module case.	Check load wiring, check ambient temperature, and check whether permissible output current (aggregate current) at the ambient temperature is exceeded After correction of the fault the module must be removed and inserted or switched off and on
Wire break	For "1" output signal only	Line break	Repair the wire break, ensure the specified minimum load (see technical specifications).
Internal error	Always	Internal module fault has occurred	Replace module
Parameter assignment error	Always	Inserted module does not match configuration incorrect parameters	Correction of configuration (compare actual and setpoint), check communication paths Correction of configuration
		PROFIsafe address set incorrectly in the F-module	Check whether the PROFIsafe address on the module matches the configuration in <i>STEP 7 HW Config</i>
Missing external auxiliary supply	Always	No supply voltage or supply voltage is too low	Check interconnected PM, Check module for correct contact After correction of the fault the module must be removed and inserted or switched off and on
Communication error	Always	Error in communication between F-CPU and module, e.g., due to defective PROFIBUS connection or higher than permissible EMI	Test PROFIBUS connection Correct faults
		PROFIsafe monitoring time set too low	Set a higher value for the "F monitoring time" parameter for the module in <i>STEP 7 HW Config</i>

Diagnostic Message	Fault Detection	Possible Causes	Corrective Measures
		Configuration of the F-module does not match fail-safe program	Generate safety program again; then load configuration and safety program into F-CPU again
Safety-related shutdown	Always	Switching frequency exceeded	Reduce the switching frequency

Generally Applicable Information on Diagnostics

For information on diagnostics that pertains to all fail-safe modules (for example for reading out diagnostic functions, passivating channels), refer to *"Diagnostics"* in this manual.

See also

Fault Diagnostics (Page 5-3)

7.6.6 Technical Specifications of the EM 4 F-DO DC24V/2A PROFIsafe

Overview

Technical Specifications	
Dimensions and Weight	
Dimensions W x H x D (mm)	30 x 81 x 52
Weight	Approx. 85 g
Data for Specific Module	
Number of outputs (P-M switching)	4
Assigned address area	
• I/O area for inputs	5 Byte
• I/O area for outputs	5 Byte
Length of cable*	
• Unshielded	200 m, maximum
• Shielded	200 m, maximum
Maximum achievable safety class	
• In accordance with IEC 61508	SIL3
• In accordance with DIN VDE 0801	AK6
• In accordance with EN 954	Category 4
Fail-safe performance characteristics	SIL3
• Low demand mode (average probability of failure on demand)	< 1,00E-05
• High demand/continuous mode (probability of a dangerous failure per hour)	< 1,00E-05
Voltages, Currents, Potentials	
Rated supply voltage L+	24 VDC
• Permissible range	20.4 V to 28.8 V
• Power loss ride-through of L+	None
• Power loss ride-through of internal P5	5 ms
• Reverse polarity protection	No
Aggregate current of outputs	
• Horizontal installation	
– Up to 40 °C	6 A
– Up to 55 °C	5 A
– Up to 60 °C	4 A
• Vertical installation	
– Up to 40 °C	4 A
Electrical isolation	
• Between channels and backplane bus	Yes
• Between channels and power supply	No
• Between channels	No
• Between channels/power supply and shield	Yes

Technical Specifications	
Permissible potential difference between	
• Shield and ET 200S bus connection	75 VDC/60 VAC
• Shield and I/O (DOs, P1/P2 buses)	75 VDC/60 VAC
• ET 200S bus connection and I/O (DOs, P1/P2 buses)	250 VAC
Isolation in the series tested with	
• Shield and ET 200S bus connection	500 VDC/1 min or 600 VDC/1 s
• Shield and I/O (DOs, P1/P2 buses)	500 VDC/1 min or 600 VDC/1 s
• ET 200S bus connection and I/O (DOs, P1/P2 buses)	1500 VAC/1 min or 2545 VDC/1 s
Isolation in the type test tested with	
• Shield and ET 200S bus connection	350 VAC/1 min
• Shield and I/O (DOs, P1/P2 buses)	350 VAC/1 min
• ET 200S bus connection and I/O (DOs, P1/P2 buses)	2830 VAC/1 min
• Impulse current test between ET 200S bus connection and I/O (DOs, P1/P2 buses)	6000 VDC/5 positive and 5 negative pulses
Current consumption	
• From backplane bus	28 mA, maximum
• From load voltage L+ (without load)	100 mA, typical
Power dissipation of the module	3.5 W, typical
Status, Interrupts, Diagnostics	
Status display	
Outputs	Green LED per channel
Diagnostic Functions	
• Group fault display	Red LED (SF)
• Diagnostic information can be displayed	Possible
Specifications for Actuator Selection*	
Output voltage	
• For "1" signal	<ul style="list-style-type: none"> • Minimum L+ (-2.0 V) • P-switch: minimum L+ (-1.5 V), voltage drop in M-switch: 0.5 V, maximum
Output current for "1" signal	
• Rated value	2 A
• Permissible range	20 mA to 2.4 A
For "0" signal (residual current)	0.5 mA, maximum
Indirect control of load by means of interface relay:	
For "0" signal (residual current)	
• P-Switch	0.5 mA, maximum
• M-Switch	4 mA, maximum
Load resistance range	12 Ω to 1 kΩ
Lamp load	10 W, maximum

Technical Specifications	
Wire break monitoring (open load detection) and overload monitoring	
• Response threshold	$I < 4$ to 19 mA
• Fault detection time	Depending on the selected readback time (see <i>Response Times</i>)
Parallel connection of 2 outputs	Not possible
Control of a digital input	Not possible
Switching frequency	
• With resistive load	30 Hz symmetrical, maximum
• With inductive load in accordance with IEC 947-5-1, DC13	0.1 Hz symmetrical, maximum
• With lamp load	10 Hz symmetrical, maximum
Voltage induced on current interruption limited to	L+ (-2x 47 V)
Short-circuit protection of output	Yes, electronic
• Response threshold (short circuit)	5 A to 12 A
• Response threshold (external M-short circuit)	5 A to 12 A
• Response threshold (external P-short circuit)	25 A to 45 A
Overload protection	Yes
• Response threshold	$I > 2.6$ A to 2.8 A
Time, Frequency	
Internal preparation times	See <i>Response Times</i>
Acknowledgment time in safety mode	4 ms minimum/8 ms maximum
Protection against Overvoltage	
Protection of supply voltage L+ from surge in accordance with IEC 61000-4-5 with external protection elements only	
• Symmetrical (L+ to M)	+ 1 kV; 1,2/50 μ s
• Asymmetrical (L+ to PE, M to PE)	+2 kV; 1,2/50 μ s
Protection of inputs and outputs from surge stressing in accordance with IEC 61000-4-5 with external protection elements only	
• Symmetrical (L+ to M)	+1 kV; 1,2/50 μ s
• Asymmetrical (L+ to PE, M to PE)	+2 kV; 1,2/50 μ s
*: In order to achieve the specified cable length, you must route the P- and M-signal lines in a cable or a non-metallic sheathed cable.	
**: For more information on the requirements for sensors and actuators see <i>Wiring and Installing Modules</i> .	

A

Diagnostic Data of Fail-Safe Modules

A.1 Introduction

Introduction

This appendix describes the structure of diagnostic data in the system data. You need to know this structure if you want to evaluate diagnostic data of fail-safe modules in the standard user program.

Further Reading

The *System and Standard Functions* reference manual describes in detail the principles of evaluating diagnostic data of F-modules in the standard user program and describes the SFCs used for this.

A.2 Structure and Content of Diagnostic Data

SFCs for Reading out Diagnostic Data

The following SFCs are available for reading out diagnostic data of fail-safe modules in the standard user program:

Table A-1 SFCs for Reading out Diagnostic Data

SFC Number	Identifier	Application
59	RD_REC	Reading out data records of S7 diagnostics (storing in data area of the standard user program)
13	DPNRM_DG	Reading out slave diagnostics (storing in data area of the standard user program)

Position in the Diagnostic Message Frame of the Slave Diagnostics

When fail-safe modules are being used in the ET 200S and a diagnostic interrupt occurs, data records 0 and 1 are entered in the slave diagnostics of the ET 200S (interrupt section).

The position of the interrupt section in the slave diagnostics depends on the structure of the diagnostic message frame and the length of the channel-related diagnostics.

You will find a detailed description of the structure of the diagnostic frame and the position of the interrupt section in accordance with the PROFIBUS standard in the section on "Commissioning and Diagnostics" in the *Distributed I/O System ET 200S* manual.

Data Records 0 and 1 of the System Data

The diagnostic data of a module can be up to 40 bytes long and is located in data records 0 and 1 of the system data area:

- Data record 0 contains 4 bytes of diagnostic data describing the state of the F-module
- Data record 1 contains
 - the 4 bytes of diagnostic data of the F-module that are also in data record 0 and
 - up to 36 bytes of channel-related diagnostic data depending on the F-module (see "*Channel-Related Diagnostics from Byte 8*").

Description

The structure and content of the individual diagnostic data bytes are described below.

In general, the following applies: If a fault occurs, the corresponding bit is set to "1".

Bytes 0 and 1

The following figure shows the content of bytes 0 and 1 of the diagnostic data.

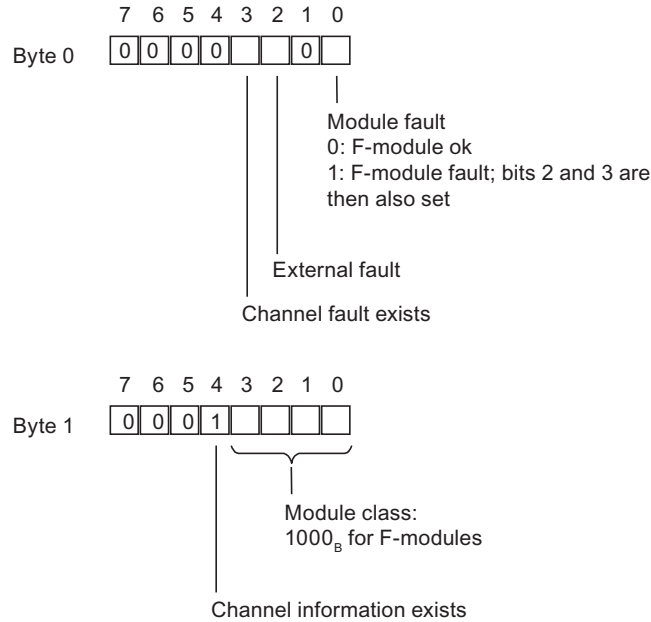

Figure A-1 Bytes 0 and 1 of diagnostic data

Bytes 2 and 3

The following figure shows the content of bytes 2 and 3 of the diagnostic data.

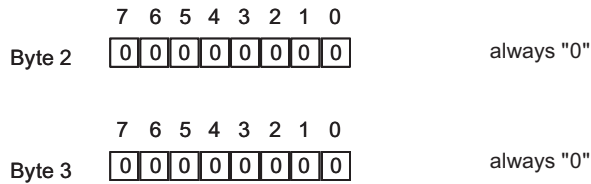

Figure A-2 Bytes 2 and 3 of diagnostic data

Bytes 4 to 6

The following figure shows the content of bytes 4 to 6 of the diagnostic data.

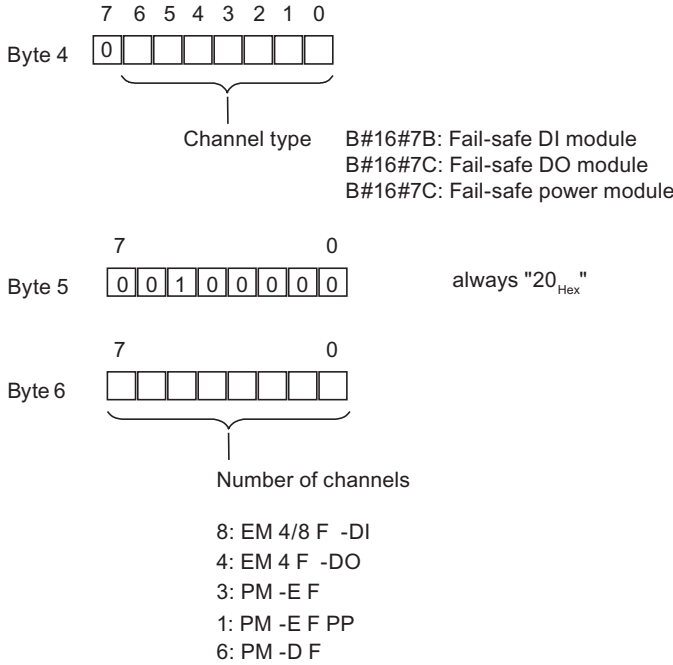

Figure A-3 Bytes 4 to 6 of diagnostic data

Byte 7 for EM 4/8 F-DI DC24V PROFIsafe

The following figure shows the content of byte 7 of the diagnostic data for the EM 4/8 F-DI DC24V PROFIsafe.

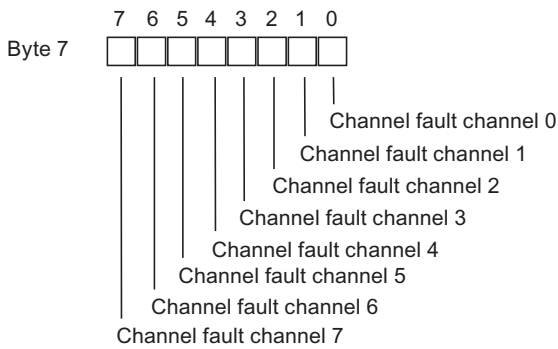

Figure A-4 Byte 7 of the Diagnostic Data for the EM 4/8 F-DI DC24V PROFIsafe

Byte 7 for the EM 4 F-DO DC24V/2A PROFIsafe

The following figure shows the content of byte 7 of the diagnostic data for the EM 4 F-DO DC24V/2A PROFIsafe.

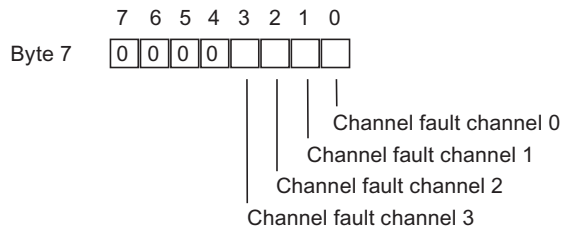

Figure A-5 Byte 7 of the Diagnostic Data for EM 4 F-DO DC24V/2A PROFIsafe

Byte 7 for PM-E F pm DC24V PROFIsafe

The following figure shows the content of byte 7 of the diagnostic data for the PM-E F pm DC24V PROFIsafe.

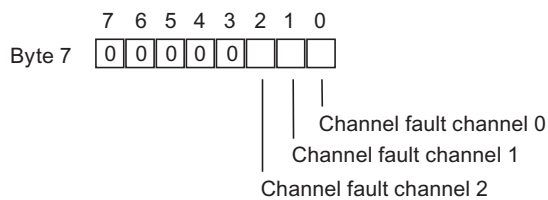

Figure A-6 Byte 7 of the Diagnostic Data for PM-E F pm DC24V PROFIsafe

Byte 7 for PM-E F pp DC24V PROFIsafe

The following figure shows the content of byte 7 of the diagnostic data for the PM-E F pp DC24V PROFIsafe

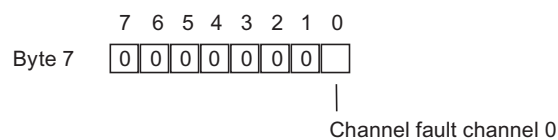

Figure A-7 Byte 7 of the Diagnostic Data for PM-E F pp DC24V PROFIsafe

Byte 7 for PM-D F DC24V PROFIsafe

The following figure shows the content of byte 7 of the diagnostic data for the PM-D F DC24V PROFIsafe.

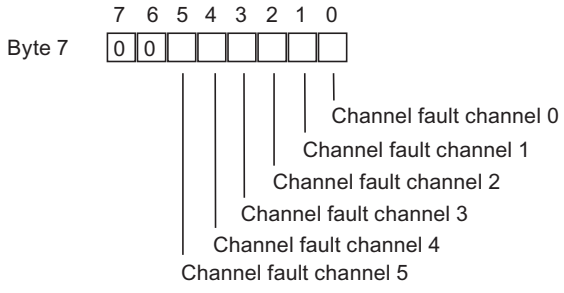

Figure A-8 Byte 7 of the Diagnostic Data for PM-D F DC24V PROFIsafe

Channel-Related Diagnostics from Byte 8

As of byte 8 of the diagnostic data the channel-related diagnosis is derived. Four bytes of diagnostic information is provided per channel.

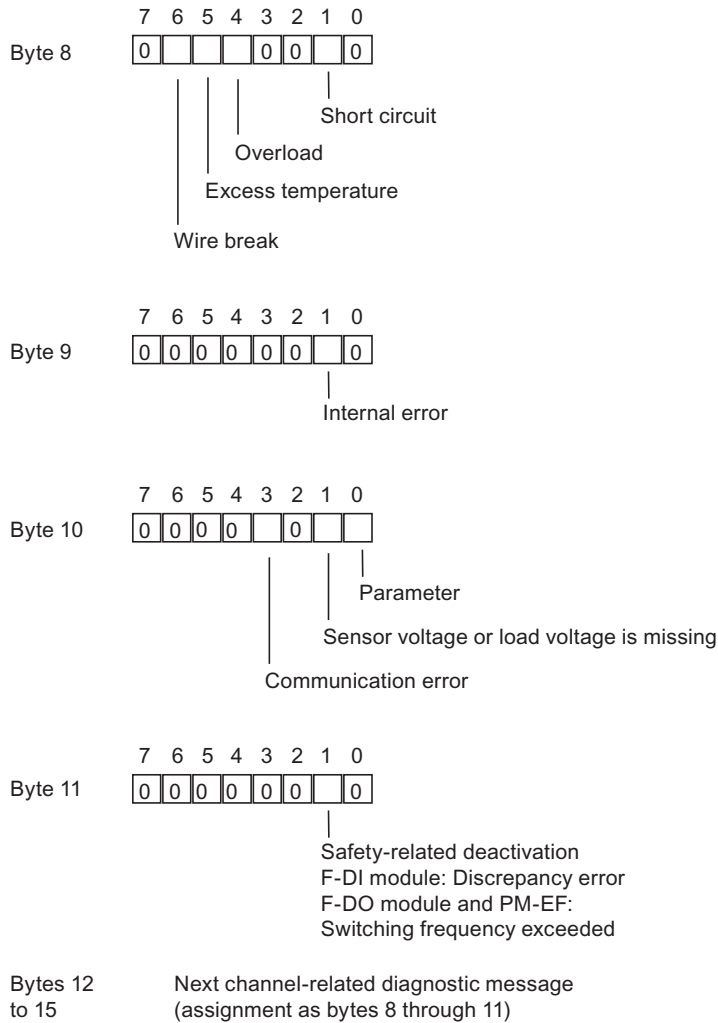

Figure A-9 Channel-Related Diagnostic Information as of Byte 8 of the Diagnostic Data

Due to the different numbers of channels of the F-modules, data record 1 has differing lengths:

EM 4/8 F-DI DC24V PROFIsafe:	40 Byte
EM 4 F-DO DC24V/2A PROFIsafe:	24 Byte
PM-E F pm DC24V PROFIsafe:	20 Byte
PM-E F pp DC24V PROFIsafe:	12 Byte
PM-D F DC24V PROFIsafe:	32 Byte

Dimension Drawings

Terminal modules with F-module inserted

Below you will find the a dimension drawing for each of the following:

- Terminal modules TM-x30x4x-xx with PM-E F pm-, PM-E F pp-, F-DI- or F-DO module inserted
- Terminal module TM-PF30S47-F1 with PM-D F-Module inserted

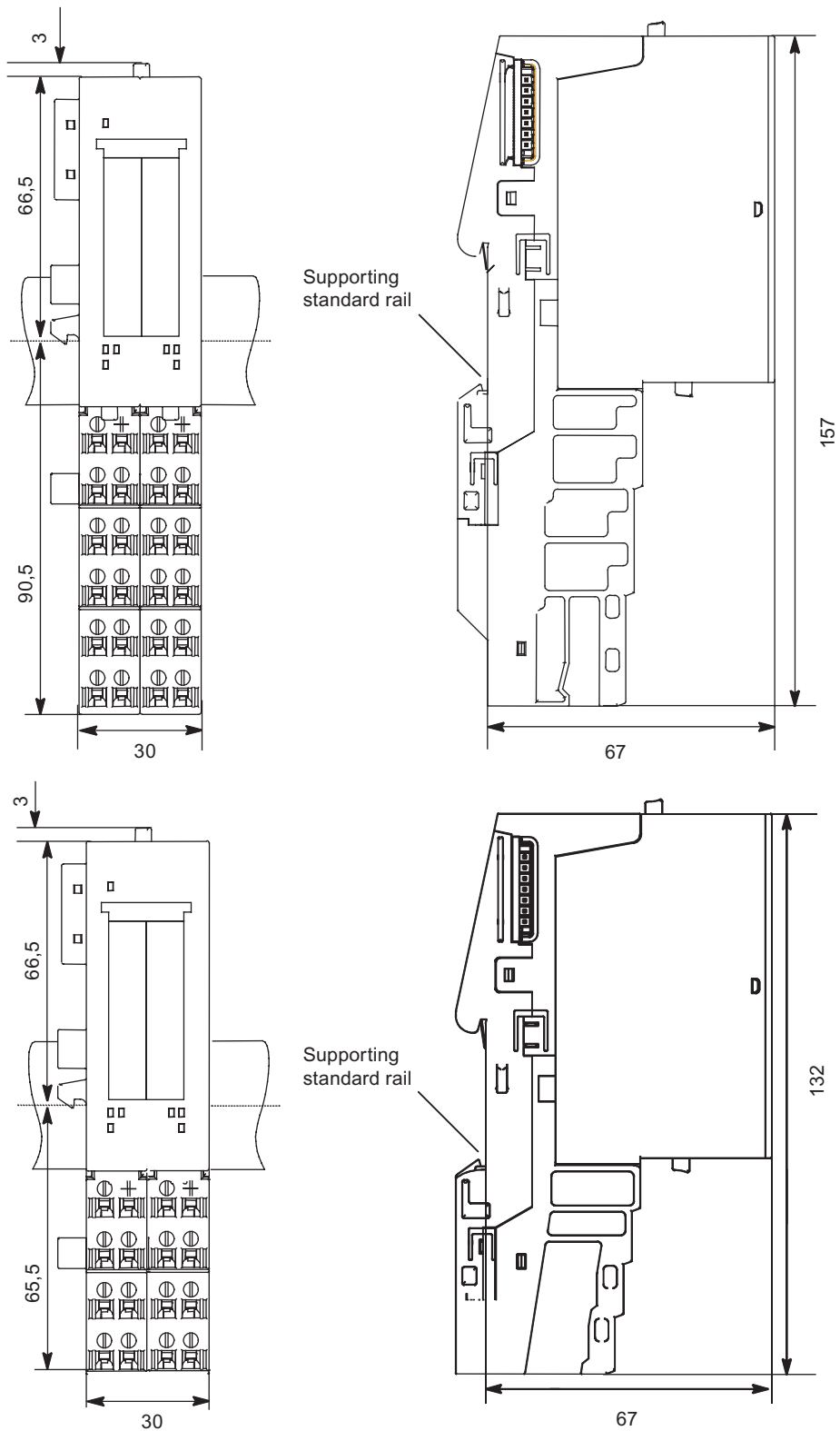

Figure B-1 Dimension Drawing of Terminal Modules with PM-E F pm, PM-E F pp, F-DI or F-DO Module Inserted

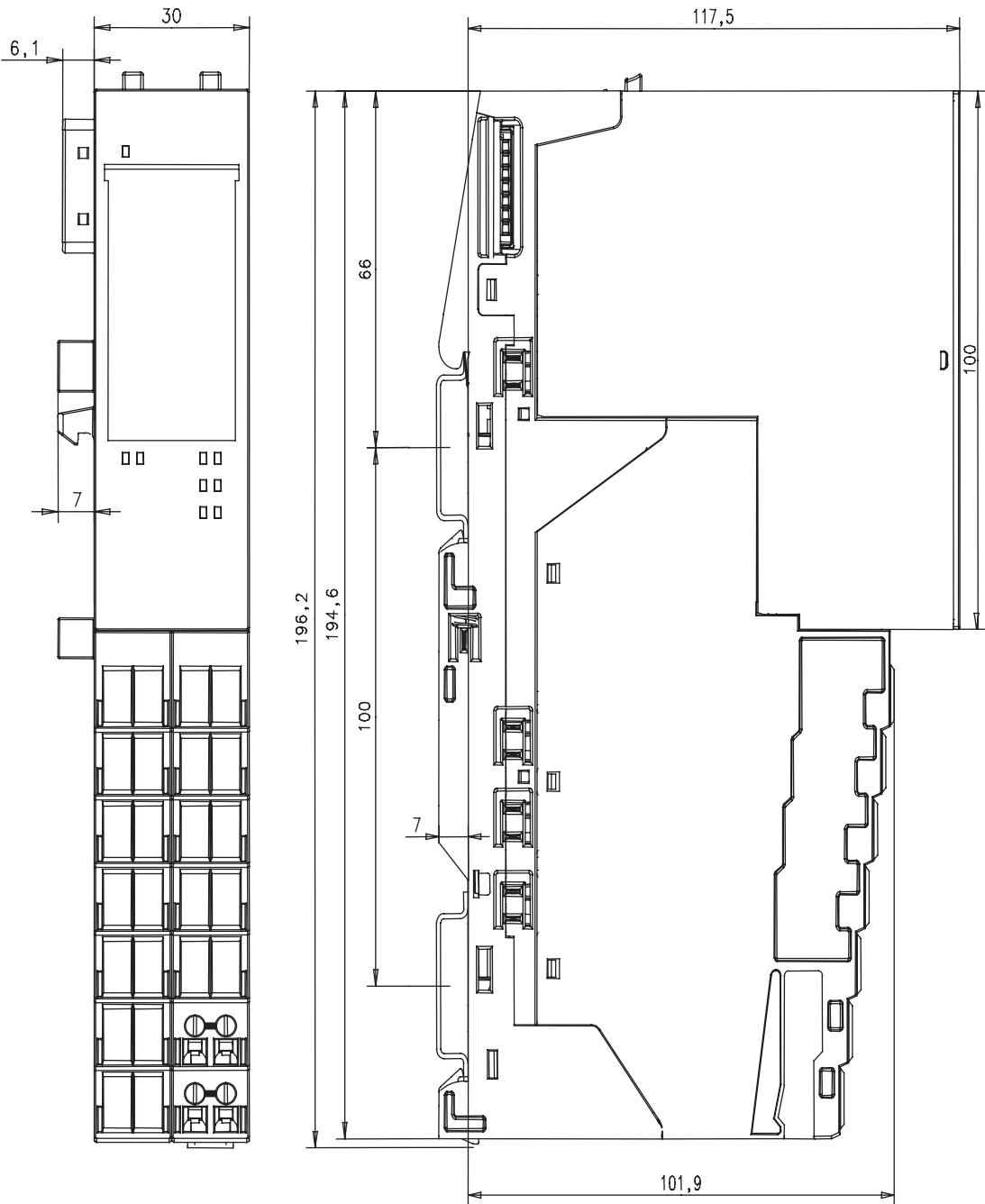

Figure B-2 Dimension Drawing of Terminal Module with PM-D F DC24V PROFIsafe inserted

Accessories and Order Numbers

Accessories and Order Numbers

The following table presents the order numbers of terminal modules, fail-safe power and electronic modules, and additional parts that can be ordered for fail-safe modules.

Component	Order Number
Terminal modules for F-DI and F-DO:	
TM-E30S44-01 (screw-in type), one item	6ES7 193-4CG20-0AA0
TM-E30C44-01 (snap-in type), one item	6ES7 193-4CG30-0AA0
TM-E30S46-A1 (screw-in type), one item	6ES7 193-4CF40-0AA0
TM-E30C46-A1 (snap-in type), one item	6ES7 193-4CF50-0AA0
Terminal modules for PM-E F pm DC24V PROFIsafe and PM-E F pp DC24V PROFIsafe:	
TM-P30S44-A0 (screw-in type), one item	6ES7 193-4CK20-0AA0
TM-P30C44-A0 (snap-in type), one item	6ES7 193-4CK30-0AA0
Terminal module for PM-D F DC24V PROFIsafe:	
TM-PF30S47-F1 (screw-in type), one item	3RK1 903-3AA00
Fail-safe power modules:	
PM-E F pm DC24V PROFIsafe	6ES7 138-4CF02-0AB0
PM-E F pp DC24V PROFIsafe	6ES7 138-4CF41-0AB0
PM-D F DC24V PROFIsafe	3RK1 903-3BA01
Fail-safe electronic module:	
4/8 F-DI 24 VDC PROFIsafe	6ES7 138-4FA02-0AB0
4 F-DO 24 VDC/2A PROFIsafe	6ES7 138-4FB02-0AB0
Accessories	
DIN A4 label sheets, yellow, quantity of 10	6ES7 193-4BB00-0AA0

Response Times

Introduction

The response times of ET 200S fail-safe modules are presented below. The response times of fail-safe modules are included in the calculation of F-system response time.

You will find information about the calculation of F-system response times in the *Safety Engineering in SIMATIC S7* system description.

Definition of Response Time

For fail-safe digital inputs: The response time is the time between a signal change at the digital input and safe loading of the safety message frame on the backplane bus.

For fail-safe digital outputs: The response time is the time between an incoming safety message frame from the backplane bus and the signal change at the digital output.

Maximum Response Time of the PM-E F pm DC24V PROFIsafe

The maximum response time of the PM-E F pm DC24V PROFIsafe (without a fault and when a fault exists) corresponds to the maximum internal conditioning time T_{\max} .

The internal conditioning times of the electronic PM channel depend on the readback time parameter setting (see table below).

Table D-1 PM-E F pm DC24V PROFIsafe: Internal processing times of the electronic PM channel

PM-E F pm DC24V PROFIsafe (electronic PM channel)			
Set Readback Time	Limit Frequency	Minimum internal processing time T_{\min}	Maximum internal processing time T_{\max}
1 ms	32.3 Hz	4 ms	16 ms
5 ms	28.6 Hz	4 ms	20 ms
10 ms	25.0 Hz	4 ms	25 ms
50 ms	12.5 Hz	4 ms	55 ms
100 ms	7.7 Hz	4 ms	90 ms
200 ms	4.3 Hz	4 ms	150 ms
400 ms	2.3 Hz	4 ms	300 ms

Table D-2 PM-E F pm DC24V PROFIsafe: Internal processing times of the P1/2 channel

Measuring Channel	Minimum internal processing time T_{min}	Maximum internal processing time T_{max}
PM-E F pm DC24V PROFIsafe (P1/2 channel; relay; turn on)	4 ms	10 ms
PM-E F pm DC24V PROFIsafe (P1/2 channel; relay; turn off)	6 ms	14 ms

Maximum Response Time of the PM-E F pp DC24V PROFIsafe

The maximum response time of the PM-E F pp DC24V PROFIsafe (without a fault and when a fault exists) corresponds to the maximum internal conditioning time T_{max} .

Table D-3 PM-E F pp DC24V PROFIsafe: Internal preparation times

Measuring Channel	Minimum internal processing time T_{min}	Maximum internal processing time T_{max}
PM-E F pp DC24V PROFIsafe (P1/2 channel; relay; turn on)	4 ms	10 ms
PM-E F pp DC24V PROFIsafe (P1/2 channel; relay; turn off)	6 ms	12 ms

Maximum Response Time of the PM-D F DC24V PROFIsafe

The maximum response time of the PM-D F DC24V PROFIsafe (without a fault and when a fault exists) corresponds to the maximum internal conditioning time T_{max} .

Table D-4 PM-D F DC24V PROFIsafe: Internal preparation times

Measuring Channel	Minimum internal processing time T_{min}	Maximum internal processing time T_{max}
PM-D F DC24V PROFIsafe (electronic PP channel)	3 ms	9 ms

Maximum Response Time of the EM 4/8 F-DI DC24V PROFIsafe

Formula for calculating the maximum response time if there is no fault:

Maximum response time
without a fault = T_{\max} + input delay + short-circuit test time*

*: Short-circuit test time = 2 x input delay

Parameters for the input delay and the short-circuit test are assigned in *STEP 7*.

Table D-5 EM 4/8 F-DI DC24V PROFIsafe: Internal preparation times

Evaluation of the Sensors	Minimum internal processing time T_{\min}	Maximum internal processing time T_{\max}
1oo1 and 2oo2	5 ms	11 ms

Maximum response time if a fault occurs:

The following table shows the maximum response times of the F-DI module when an error/fault is present, depending on the parameter assignment in *STEP 7* and the evaluation of the sensors.

Table D-6 EM 4/8 F-DI DC24V PROFIsafe: Maximum Response Time if a Fault Occurs:

Input delay	1oo1 evaluation			1oo2 evaluation**		
	0.5 ms	3 ms	15 ms	0.5 ms	3 ms	15 ms
Short-circuit test deactivated	18 ms	20 ms	32 ms	12 ms	14 ms	26 ms
Short-circuit test activated	29 ms	40 ms	91 ms	13 ms	20 ms	56 ms

: With **1oo2 evaluation the response times also depend on the configured discrepancy response:
Provide 0 value: The times in the above table apply.
Provide last valid value The times in the above table extend to the configured discrepancy time.

Note

Please note that the Excel files for calculation of the maximum response times (*s7fcotib.xls* and *s7ftimeb.xls*) provided with the *S7 Distributed Safety* and *S7 F/FH Systems* option packages already supports calculation of the extension of the "Maximum responses time in the event of a fault" by the configured discrepancy time.

Maximum Response Time of the EM 4 F-DO DC24V/2A PROFIsafe

The maximum response time of the EM 4 F-DO DC24V/2A PROFIsafe (without a fault and when a fault exists) corresponds to the maximum internal conditioning time T_{max} .

The internal conditioning times of the electronic PM channel depend on the readback time parameter setting (see table below).

Table D-7 EM 4 F-DO DC24V/2A PROFIsafe: Internal preparation times

EM 4 F-DO DC24V/2A PROFIsafe (electronic PM channel)			
Set Readback Time	Limit Frequency	Minimum internal processing time T_{min}	Maximum internal processing time T_{max}
1 ms	32.3 Hz	4 ms	16 ms
5 ms	28.6 Hz	4 ms	20 ms
10 ms	25.0 Hz	4 ms	25 ms
50 ms	12.5 Hz	4 ms	55 ms
100 ms	7.7 Hz	4 ms	90 ms
200 ms	4.3 Hz	4 ms	150 ms
400 ms	2.3 Hz	4 ms	300 ms

See also

Properties of the 4/8 F-DI 24 VDC PROFIsafe Digital Electronic Module (Page 7-47)

Glossary

1oo1 Evaluation

-> 1oo1 Evaluation

Type of -> sensor evaluation – In 1oo1 evaluation, one -> sensor is connected to the F-module by a single channel.

1oo2 Evaluation

-> 1oo2 Evaluation

Type of -> sensor evaluation - In 1oo2 evaluation, two input channels are occupied, either by one 2-channel sensor or two single-channel sensors. The input signals are compared internally for equivalence or non-equivalence.

Acknowledgment Time

During the acknowledgement time, the -> F-I/O acknowledge the sign of life specified by the -> F-CPU. The acknowledgement time enters into the calculation of the -> monitoring time and -> response time for the F-system as a whole.

Actuator

Actuators can be power relays or contactors for switching on consumers, or they can be consumers themselves (for example, directly controlled solenoid valves).

AUX1 Bus

Power modules allow the additional connection of a voltage (24 V DC) that you can apply over the AUX(iliary) bus. AUX(iliary) buses can be used individually as a protective conductor bus or they can be used to supply additional voltage.

Availability

Availability is the probability that a system is functional at a specific point in time. It can be increased by redundancy, for example, by using multiple -> sensors at the same measuring point.

Backplane bus

The backplane bus is a serial data bus used by the interface module IM 151 to communicate with the electronic modules and motor starters and to supply them with the required voltage.

The connection between individual modules is established by means of the terminal modules.

Category

Category in accordance with EN 954-01

-> Fail-safe modules can be used in safety mode up to Category 4.

Channel error

This is a channel-specific error, such as a wire break or a short circuit.

In channel-specific passivation, the affected channel is either automatically reintegrated or the F-module must be removed and reinserted after the fault has been eliminated.

Channel Group

The channels of a module are grouped together in a channel group. Certain parameters in STEP 7 can only be assigned to channel groups, rather than to individual channels.

Channel Number

Channel numbers are used to uniquely identify the inputs and outputs of a module and to assign channel-specific diagnostic messages.

Channel-Granular Passivation

In this passivation method, when a -> channel fault occurs, only the channel involved is passivated (method available in S7 F/FH systems only). In the event of a -> module fault, all channels of the -> fail-safe module are passivated.

Configuring

A configuration is a systematic arrangement of the individual modules of ET 200S.

Connection to Common Potential

Connection to common potential refers to the opening of a new potential group by a power module.

This enables individual connection of encoder and load current power supplies.

CRC

Cyclic Redundancy Check -> signature

CRC signature

The validity of the process values in the safety message frame, the accuracy of the assigned address references, and the safety-related parameters are ensured by means of a CRC signature contained in the safety message frame.

Dark Period

Dark periods occur during switch-off tests and during complete bit pattern tests. This involves test-related 0 signals being switched to the output by the fail-safe output module while the output is active. The output is then switched off briefly (dark period). A sufficiently slow -> actuator does not respond and remains switched on.

Discrepancy analysis

The discrepancy analysis for equality/non-equality is used with fail-safe inputs to detect errors based on the timing of two signals with the same functionality. Discrepancy analysis starts when different levels (when checking for non-equality: the same level) of two related input signals are detected. The signals are checked to establish whether the difference (when checking for non-quality: the match) has disappeared following a selectable time known as the discrepancy time. If not, a discrepancy error is recognized.

A discrepancy analysis is carried out between the two input signals of the 1oo2 sensor evaluation in the fail-safe input module.

Discrepancy Time

Discrepancy time is a period of time configured for the -> discrepancy analysis. If the discrepancy time is set too high, the times for fault detection and -> fault reaction are extended unnecessarily. If the discrepancy time is set too low, availability is decreased unnecessarily because a discrepancy error is detected when, in reality, no error exists.

DP Master

A master that behaves in compliance with the IEC 61784-1:2002 Ed1 CP 3/1 standard is known as a DP master.

DP slave

A DP slave is a slave operated on PROFIBUS with the PROFIBUS-DP protocol that behaves in compliance with the IEC 61784-1:2002 Ed1 CP 3/1 standard.

F monitoring time

-> PROFIsafe monitoring time

Fail-Safe Modules

ET 200S modules that can be used for safety-related operation (-> safety mode) in the ET 200S distributed I/O system. These modules are equipped with integrated -> safety functions.

Fail-Safe Systems

Fail-safe systems (F-systems) are systems that remain in a safe state or immediately switch to another safe state as soon as particular failures occur.

Fault Response Time

The maximum fault response time for an F-system is the time between the occurrence of any fault and a safe response at all affected fail-safe outputs.

For -> F-Systems in general: The maximum fault response time begins with the occurrence of any fault in any -> F-I/O module and ends with a safe response at the associated fail-safe output.

For digital inputs, The maximum fault response time begins with the occurrence of the fault and ends with the safe response on the backplane bus.

For digital outputs, The maximum fault response time begins with the occurrence of the fault and ends with the safe response at the digital output.

Fault Tolerance Time

The fault tolerance time of a process is the time interval during which the process can be left on its own without risk to life and limb of the operating personnel or damage to the environment.

Within the fault tolerance time, any type of F-system process control is tolerated. That is, during this time, the -> F-system can control its process incorrectly or it can even exercise no control at all. The fault tolerance time depends on the process type and must be determined on a case-by-case basis.

F-CPU

An F-CPU is a central processing unit with fail-safe capability that is permitted for use in S7 Distributed Safety/S7 F/FH systems.

For S7 F/FH systems, the F-copy license allows the central processing unit to be used as an F-CPU. In other words, it can execute a -> safety program.

For S7 Distributed Safety, an F-copy license is not required. A -> standard user program can also be run on the F-CPU.

F-I/O

F-I/O is a group designation for fail-safe inputs and outputs available in SIMATIC S7 for integration in S7 Distributed Safety and S7 F/FH systems. The following F-I/O modules are available:

- Fail-safe I/O module for ET 200eco
- S7-300 fail-safe signal modules (F-SMs)
- Fail-safe modules for ET 200S
- Fail-safe DP standard slaves (for S7 Distributed Safety only)

F-Systems

-> Fail-safe systems

Module Fault

Module faults can be external faults (for example, missing load voltage) or internal faults (for example, processor failure). An internal fault always requires module replacement.

Monitoring time

-> PROFIsafe monitoring time

Motor Starter (MS)

Motor starter is a general term referring to direct starters and reversing starters. Motor starters are used to specify motor startup and direction of rotation.

M-Switch

In the ET 200S fail-safe modules, every fail-safe digital output consists of a P-switch DOx P (current sourcing) and an M-switch DOx M (current sinking). The load is connected between the P and M-switches. The two switches are always controlled so that voltage is applied to the load.

Nonequivalent Sensor

A nonequivalent -> sensor is a reversing switch that is connected to two inputs of an -> F-I/O (via 2 channels) in -> F-systems (for -> 1oo2 evaluation of sensor signals).

Parameter assignment

Configuration with PROFIBUS-DP: Transfer of slave parameters from the DP master to the DP slave

Configuration of modules/submodules: Setting the behavior of modules/submodules with the STEP 7 configuration software

Passivation

If an -> F-I/O module detects a fault, it switches either the affected channel or all channels to a -> safe state; that is, the channels of the F-I/O module are passivated. The F-I/O signals the detected faults to the -> F-CPU.

For an F-I/O with inputs, if passivation occurs, the F-system provides fail-safe values for the safety program instead of the process values pending at the fail-safe inputs.

For an I/O module with outputs, if passivation occurs, the F-system transfers fail-safe values (0) to the fail-safe outputs instead of the output values provided by the safety program.

PD

Programming Device (PD): Personal Computer in special compact industrial design. A PD is fully equipped for programming SIMATIC automation systems.

Prewiring

Prewiring means wiring the terminal modules before inserting the electronic modules.

Process image

The process image is a component of the system memory of the CPU. At the beginning of the cyclic program, the signal states of the inputs are transferred to the process input image. At the end of the cyclic program, the process output image is transferred to the outputs as the signal state.

PROFIBUS

PROcess **F**ield **B**US, process and fieldbus standard specified in IEC 61784-1:2002 Ed1 CP 3/1. This standard specifies functional, electrical, and mechanical properties for a bit-serial field bus system.

PROFIBUS is available with the following protocols: DP (= distributed I/O), FMS (= Fieldbus message specification), PA (= Process automation), or TF (= Technological functions).

PROFINET IO

PROFINET IO is the PROFINET communication concept for implementing modular, distributed applications.

PROFINET IO enables creation of automation solutions using the familiar, proven methods of PROFIBUS.

PROFINET IO is implemented based on both the PROFINET standard for automation devices and the *STEP 7* engineering tool.

This means that you have the same application view in *STEP 7*, regardless of whether you are configuring PROFINET or PROFIBUS devices. Creation of your user program is similar for PROFINET IO and PROFIBUS DP, provided you use the expanded blocks and system status lists for PROFINET IO.

PROFINET IO Controller

A PROFINET IO controller is a device that is addressed via the connected IO device. That is, the IO controller exchanges input and output signals with assigned field devices. The IO controller is often the controller in which the automation program runs.

PROFINET IO Device

A PROFINET IO device is a decentralized field device that is assigned to one of the IO controllers (e.g., remote IO, valve terminals, frequency converters, switches)

PROFINET IO Supervisor

A PROFINET IO supervisor is a programming device/PC or HMI device used for commissioning and diagnostics.

PROFINET IO controller with assigned PROFINET IO devices

PROFIsafe

Safety-related PROFIBUS DP/PA bus profile for communication between the -> safety program and the -> F-I/O in an -> F-system.

PROFIsafe Address

Every -> fail-safe module has a PROFIsafe address You must configure the PROFIsafe address in STEP 7 HW Config and set it on the F-I/O using a switch.

PROFIsafe Monitoring Time

Monitoring time for safety-related communication between the F-CPU and F-I/O

Proof-Test Interval

A component must be set in the fail-safe state following the proof-test interval. That is, it is replaced by an unused component or it is proven to be completely error-free.

P-Switch

-> See M-Switch.

Redundancy, availability-enhancing

Availability-enhancing redundancy means multiple availability of components to ensure that components continue to function even in the event of hardware faults.

Redundancy, safety-enhancing

Multiple installations of components with the goal of reducing hardware faults; for example, -> 1oo2 evaluation in -> fail-safe modules.

Reintegration

Once a fault has been eliminated, the -> F-I/O must be reintegrated (depassivated). The reintegration (switchover from fail-safe values to process values) occurs either automatically or only after user acknowledgement in the safety program.

For an F-I/O module with inputs, the process values pending at the fail-safe inputs are provided again for the -> safety program after reintegration. For an F-I/O module with outputs, the -> F-system again transfers the output values provided in the safety program to the fail-safe outputs.

Requirement Classes

Safety requirement class (AK) in accordance with DIN V 19250 (DIN V VDE 0801):

Safety requirement classes are a means of categorizing safety requirements for preventing and remedying faults. With -> fail-safe modules, safety requirement classes up to A6 can be used in -> safety mode.

Response time

Response time starts with the detection of an input signal and ends with the modification of a gated output signal.

The actual response time is between the shortest and the longest response time. The longest response time must always be anticipated.

For fail-safe digital inputs: The response time is the time between a signal change at the digital input and safe loading of the -> safety message frame on the backplane bus.

For fail-safe digital outputs: The response time is the time between an incoming safety message frame from the backplane bus and the signal change at the digital output.

Reversing Starter

A reversing starter is a -> motor starter that determines the rotational direction of a motor. It comprises a circuit-breaker and two contactors.

Safe State

The basic principle of the safety concept in F-systems is the existence of a safe state for all process variables. For the digital F-I/O, the safe state is, for example, the value "0".

Safety function

Safety function is a mechanism built into the -> F-CPU and -> F-I/O that allows them to be used in -> S7 Distributed Safety or S7 F/FH systems.

In accordance with IEC 61508: a safety function is implemented by a safety system to ensure that the system is kept in a safe state or brought into a safe state in the event of a particular fault

Safety Integrity Level

Safety Integrity Level (SIL) in accordance with IEC 61508 and prEN 50129. The higher the Safety Integrity Level the more rigid the measures for prevention of systematic faults and for management of systematic faults and hardware failures.

Safety modules can be used in safety mode up to SIL3.

Safety message frame

In safety mode, data is transferred between the -> F-CPU and the -> F-I/O in a safety message frame.

Safety Mode

Safety mode is the operating mode of the -> F-I/O that allows -> safety-related communication by means of -> safety message frames.

ET 200S -> fail-safe modules are designed for operation only in safety mode.

Safety Program

The safety program is a safety-related user program.

Safety-related communication

Safety-related communication is used to exchange fail-safe data.

Sensor Evaluation

There are two types of sensor evaluation:

-> 1oo1 evaluation - Sensor signal is read in once

-> 1oo2 evaluation - Sensor signal is read in twice from the same F-module and compared internally

Sensors

Sensors permit exact acquisition of digital and analog signals and exact measurement of routes, positions, velocities, rotational speeds, weights, etc.

Standard Mode

Operating mode of F-I/O, in which standard communication is possible but not -> safety-related communication by means of safety message frames.

Fail-safe signal modules of S7-300 can be used in standard mode or -> safety mode. Fail-safe modules of ET 200S are designed for safety mode only.

Static Parameter

Static parameters can only be set when the CPU is in STOP mode and cannot be changed by means of SFC (system function) while the user program is running.

Terminal Module

The ET 200S distributed I/O system is terminated with the terminal module. If a terminal module is not inserted, the ET 200S is not ready for operation.

Voltage Bus (P1/P2)

Voltage buses (P1 and P2) are two internal buses that supply the electronic modules with voltage. The voltage buses are fed by the power module and are connected by means of the terminal module.

Voltage Group

A voltage group is a group of electronic modules supplied by a power module.

Index

1

- 1 VsF LED, 5-4
 - EM 4/8 F-DI DC24V PROFIsafe, 7-74
- 1oo1 evaluation
 - EM 4/8 F-DI DC24V PROFIsafe, 7-56
- 1oo2 evaluation
 - EM 4/8 F-DI DC24V PROFIsafe, 7-62, 7-63, 7-65, 7-67, 7-70, 7-71, 7-72

2

- 2 VsF LED, 5-4
 - EM 4/8 F-DI DC24V PROFIsafe, 7-74

A

- Accessories
 - Order numbers, C-1
- Acknowledgment Time
 - EM 4 F-DO DC24V/2A PROFIsafe, 7-95
 - EM 4/8 F-DI DC24V PROFIsafe, 7-79
 - PM-E F 24 VDC PROFIsafe, 7-46
 - PM-E F pm DC24V PROFIsafe, 7-23
 - PM-E F pp DC24V PROFIsafe, 7-36
- Actuators
 - externally supplied, 4-2
 - Requirements, 4-6
 - with sufficient lag, 4-7
- Additional potential connection, 2-3
- Address
 - PROFIsafe, 3-3
- Address Assignment
 - F-modules in F-CPU, 3-1
 - PROFIsafe, 3-3
 - Useful data in F-CPU, 3-2
- Address switch
 - for PROFIsafe addresses, 3-3
 - setting, 3-3
- Applications
 - EM 4/8 F-DI DC24V PROFIsafe, 7-54

Approval

- CE, 6-2
 - CSA, 6-2
 - cULus, 6-3
 - FM, 6-4
 - Shipbuilding, 6-5
 - UL, 6-2
- Assignable diagnostics
 - functions, 5-4
 - Assignment
 - Fail-safe inputs, 7-58, 7-69
 - Automation system
 - fail-safe, 1-1
 - AUX1 Bus, 2-3

B

- Basic knowledge, required, iii
- Behavior
 - For module failure, 5-7
 - With discrepancy, 7-52
- Block Diagram
 - EM 4 F-DO DC24V/2A PROFIsafe, 7-84
 - EM 4/8 F-DI DC24V PROFIsafe, 7-50
 - PM-D F DC24V PROFIsafe, 7-41
 - PM-E F pm DC24V PROFIsafe, 7-11
 - PM-E F pp DC24V PROFIsafe, 7-29

C

- Cables
 - shielded, 7-51
- Capacitive crosstalk
 - input signals, 7-7
 - output signals, 7-7
- Capacitive loads
 - connecting, 7-15, 7-88
- Category (Cat.)
 - achievable, 1-4
- Causes of errors
 - EM 4 F-DO DC24V/2A PROFIsafe, 7-91
 - PM-E F pm DC24V PROFIsafe, 7-18

- Causes of faults
 - EM 4/8 F-DI DC24V PROFIsafe, 7-75
 - PM-D F DC24V PROFIsafe, 7-44
 - PM-E F pp DC24V PROFIsafe, 7-33
 - CE approval, 6-2
 - Changes
 - in this manual, iii
 - Channel
 - deactivated, 5-1
 - Channel fault, 5-2
 - Channel group fault, 5-1
 - Channel-specific diagnostics
 - as of byte 8 in the diagnostic data, A-7
 - of F-modules, 5-5
 - Climatic conditions
 - approved, 6-13
 - Commissioning
 - of ET 200S, 1-5
 - Communication error, 4-4, 5-6
 - EM 4 F-DO DC24V/2A PROFIsafe, 7-90
 - EM 4/8 F-DI DC24V PROFIsafe, 7-74
 - F-DI Module Reaction, 5-2
 - PM-D F DC24V PROFIsafe, 7-43
 - PM-E F pm DC24V PROFIsafe, 7-17
 - PM-E F pp DC24V PROFIsafe, 7-32
 - Conditions
 - for safety class with EM 4 F-DO DC24V/2A PROFIsafe, 7-80
 - For safety class with EM 4/8 F-DI DC24V PROFIsafe, 7-47, 7-55
 - for safety class with PM-D F DC24V PROFIsafe, 7-38
 - for safety class with PM-E F pm DC24V PROFIsafe, 7-3
 - for safety class with PM-E F pp DC24V PROFIsafe, 7-25
 - Of use, 6-12
 - Transport and storage of F-Modules, 6-11
 - Conditions of use, 6-12
 - Configuration
 - ET 200S with F-motor starters, 2-2
 - F-System with ET 200S, 2-1
 - Configuration example
 - Voltage Group, 2-1
 - with F-motor starters:, 2-2
 - Configuration rules
 - F-potential groups, 2-2
 - Configuring
 - F-modules, 2-8
 - Connecting
 - two relays on one digital output, 7-13
 - Connecting capacitive loads, 7-15, 7-88
 - Connecting grounded loads
 - With EM 4 F-DO DC24V/2A PROFIsafe, 7-81
 - with PM-E F pm DC24V PROFIsafe, 7-6
 - Connection to Common Potential
 - power modules, 2-3
 - Conventions
 - in this manual, vi
 - Corrective Measures
 - EM 4 F-DO DC24V/2A PROFIsafe, 7-91
 - EM 4/8 F-DI DC24V PROFIsafe, 7-75
 - PM-D F DC24V PROFIsafe, 7-44
 - PM-E F pm DC24V PROFIsafe, 7-18
 - PM-E F pp DC24V PROFIsafe, 7-33
 - Cross Circuit
 - EM 4 F-DO DC24V/2A PROFIsafe, 7-86
 - PM-E F pm DC24V PROFIsafe, 7-13
 - CSA Approval, 6-2
 - cULus approval, 6-3
 - Current carrying capacity
 - maximum, 2-7
- ## D
- Dark Period
 - of actuators, 4-7
 - Deactivated channel, 5-1
 - Determining parameter length
 - F-modules, 2-6
 - Determining parameter length, 2-6
 - diagnostic data
 - Byte 7 for EM 4/8 F-DI DC24V PROFIsafe, A-4
 - Byte 7 for PM-D F DC24V PROFIsafe, A-6
 - Byte 7 for PM-E F pm DC24V PROFIsafe, A-5
 - Byte 7 for PM-E F pp DC24V PROFIsafe, A-5
 - Byte 7 in EM 4 F-DO DC24V/2A PROFIsafe, A-5
 - Bytes 0 and 1, A-3
 - Bytes 2 and 3, A-3
 - Bytes 4 to 6, A-4
 - Position in message frame, A-2
 - Structure and contents, A-2
 - Diagnostic functions
 - PM-D F DC24V PROFIsafe, 7-42, 7-43
 - PM-E F pm DC24V PROFIsafe, 7-17
 - Diagnostic Functions, 5-3
 - can be activated by user, 5-4
 - cannot be activated by user, 5-3
 - EM 4 F-DO DC24V/2A PROFIsafe, 7-90
 - EM 4/8 F-DI DC24V PROFIsafe, 7-74
 - PM-E F pp DC24V PROFIsafe, 7-32
 - PM-E F pp DC24V PROFIsafe, 7-32
 - Reading out, 5-7

- Diagnostics
 - at the slave, 5-4
 - By LED display, 5-4
 - channel-specific, 5-5
 - Purpose, 5-3
 - Digital I/O module
 - fail-safe, 1-2
 - Digital output
 - Connecting to two relays, 7-13
 - Dimension Drawings
 - F-Modules, B-1
 - Directives, 6-6
 - Discrepancy analysis, 7-53
 - Discrepancy behavior, 7-52
 - EM 4/8 F-DI DC24V PROFIsafe, 7-51
 - Discrepancy error
 - EM 4/8 F-DI DC24V PROFIsafe, 7-74
 - Discrepancy Time, 7-53
 - EM 4/8 F-DI DC24V PROFIsafe, 7-51
 - Disposal, vi
 - Distributed I/O system
 - Definition, 1-1
 - Documentation, additional, v
 - Duration of sensor signals
 - Requirements, 4-7
- E**
- Electrical connection, 4-2
 - Electromagnetic Compatibility, 6-7
 - Electronics power supply, failure of
 - PM-D F DC24V PROFIsafe, 7-42
 - EM 4 F-DO DC24V/2A PROFIsafe
 - acknowledgment time, 7-95
 - Block Diagram, 7-84
 - Byte 7 of the diagnostic data, A-5
 - Connecting grounded loads, 7-81
 - Diagnostic Functions, 7-90
 - Fail-safe performance characteristics, 7-93
 - Fault types, 5-6
 - Faults and Remedies, 7-91
 - Front View, 7-82
 - Maximum response time, D-4
 - Order Number, 7-80
 - Parameters in STEP 7, 7-88
 - Readback Time, 7-88
 - Technical Specifications, 7-93
 - Terminal assignment, 7-83
 - Wiring Diagram, 7-85
 - EM 4/8 F-DI DC24V PROFIsafe
 - acknowledgment time, 7-79
 - Applications, 7-54
 - Block Diagram, 7-50
 - Byte 7 of the diagnostic data, A-4
 - Diagnostic Functions, 7-74
 - Discrepancy Time, 7-53
 - Fail-safe performance characteristics, 7-77
 - Fault types, 5-6
 - Faults and Remedies, 7-75
 - Front View, 7-48
 - Input delay, 7-51
 - Maximum response time, D-3
 - Order Number, 7-47
 - Parameters in STEP 7, 7-51
 - Sensor supply, 7-58, 7-69
 - Sensor Supply, 7-56
 - Short-circuit test, 7-52
 - Special features for fault detection, 7-57, 7-61, 7-64, 7-68, 7-73
 - Technical Specifications, 7-77
 - terminal assignment, 7-49
 - Wiring diagram, 7-59, 7-62, 7-65, 7-67, 7-70, 7-71, 7-72
 - Wiring Diagram, 7-56, 7-63
 - EMC, 6-7
 - Emission
 - of radio interference, 6-11
 - Environment-Related requirements, 6-12
 - climatic, 6-13
 - Mechanical, 6-12
 - ET 200S
 - Commissioning, 1-5
 - Distributed I/O system, 1-1
 - External protective circuit, 6-8
 - protection from overvoltage, 6-8
- F**
- F Configuration Pack, 2-8
 - F monitoring time
 - EM 4 F-DO DC24V/2A PROFIsafe, 7-88
 - EM 4/8 F-DI DC24V PROFIsafe, 7-51
 - PM-D F DC24V PROFIsafe, 7-42
 - PM-E F pm DC24V PROFIsafe, 7-15
 - PM-E F pp DC24V PROFIsafe, 7-31
 - F_destination_address, 3-3
 - EM 4 F-DO DC24V/2A PROFIsafe, 7-88
 - EM 4/8 F-DI DC24V PROFIsafe, 7-51
 - PM-D F DC24V PROFIsafe, 7-42
 - PM-E F pm DC24V PROFIsafe, 7-15
 - PM-E F pp DC24V PROFIsafe, 7-31
 - F_Source_Address, 3-3

- Fail-safe automation systems, 1-1
 - Fail-Safe Module
 - reintegration, 5-2
 - Fail-safe performance characteristics
 - EM 4 F-DO DC24V/2A PROFIsafe, 7-93
 - EM 4/8 F-DI DC24V PROFIsafe, 7-77
 - PM-D F DC24V PROFIsafe, 7-45
 - PM-E F pm DC24V PROFIsafe, 7-20
 - PM-E F pp DC24V PROFIsafe, 7-34
 - Scope, 7-1
 - Fail-safe value output
 - for fail-safe modules, 5-2
 - Fault detection
 - EM 4/8 F-DI DC24V PROFIsafe, 7-57, 7-61, 7-64, 7-68, 7-73
 - Fault reaction
 - of F-modules, 5-1
 - Fault types
 - of F-modules, 5-6
 - F-CPU
 - Addresses Occupied by Useful Data, 3-2
 - F-DI Module Reaction
 - to communication errors, 5-2
 - F-Electronic Module
 - Usable terminal modules, 2-4
 - F-inputs
 - Assignment, 7-58, 7-69
 - FM approval, 6-4
 - F-modules, 1-2
 - Address assignment in F-CPU, 3-1
 - available, 1-3
 - Configuration, 2-8
 - installing, 3-4
 - Mixing with standard modules, 2-1
 - Mounting Dimensions, 3-4
 - Parameter Assignment, 2-8
 - Parameter length, 2-6
 - possible uses, 1-2
 - Use in F-systems, 1-2
 - F-Modules
 - Dimension Drawings, B-1
 - Fault reaction, 5-1
 - inserting and removing, 4-4
 - Insertion and Removal during Operation, 4-5
 - Output fail-safe values, 5-2
 - Response Times, D-1
 - wiring, 4-3
 - F-motor starters:
 - Configuration example, 2-2
 - F-potential groups
 - Configuration rules, 2-2
 - F-Power Module
 - Usable terminal modules, 2-4
 - F-System with ET 200S
 - Configuration, 2-1
 - F-Systems, 1-1
 - example configuration, 1-3
 - Functional extra low voltage
 - safe, 4-2
 - functions
 - For diagnostic, 5-3
 - Fuse, external
 - PM-E F pm DC24V PROFIsafe, 7-12
 - PM-E F pp DC24V PROFIsafe, 7-30
- ## G
- General technical specifications, 6-1
 - Guide
 - To manual, vi
- ## H
- H/F Competence Center, vi
- ## I
- I/O system
 - Distributed, 1-1
 - IEC 61131, 6-4
 - Information
 - About this manual, iii
 - Input delay, 4-7
 - EM 4/8 F-DI DC24V PROFIsafe, 7-51
 - input signals
 - Capacitive crosstalk, 7-7
 - Inserted F-module (dimensional diagram)
 - With terminal modules, B-1
 - Inserting
 - F-Module, 4-4
 - Insertion and Removal
 - F-modules in operation, 4-4
 - Installing
 - F-modules, 3-4
 - Installing the chassis cable
 - PM-E F pp DC24V PROFIsafe, 7-25
 - Insulation stability, 6-14
 - Interface module
 - Can be used for ET 200S, 1-4
 - Interference
 - pulse-shaped, 6-7
 - sinusoidal, 6-10
 - Internal error
 - EM 4 F-DO DC24V/2A PROFIsafe, 7-90
 - PM-E F pm DC24V PROFIsafe, 7-17

- Internal fault
 - EM 4/8 F-DI DC24V PROFIsafe, 7-74
 - PM-D F DC24V PROFIsafe, 7-43
 - PM-E F pp DC24V PROFIsafe, 7-32
 - react to, 5-7
- Internal sensor power supply, 7-52
- Internet
 - Service & Support, vii
- IP20, 6-14

- L**
- Lag requirement
 - at actuators, 4-7
- LED display
 - Diagnostics, 5-4
 - of faults, 5-4
- Limitation of maximum configuration, 2-7
- Line break, 5-6
- Line cross section, 4-2
- Literature, additional, v
- Load current power supply, failure of
 - PM-D F DC24V PROFIsafe, 7-42
- Load voltage missing, 5-6
- Loads
 - capacitive switching, 7-15, 7-88
 - Connecting grounded loads, 7-6

- M**
- Machine protection
 - applications in, 5-4
- Manual
 - Contents, vi
 - Purpose, iii
 - Scope, iii
- Marking for Australia, 6-4
- Maximum configuration
 - F-System with ET 200S, 2-6
 - Limitation, 2-7
 - per voltage group, 2-7
- Maximum response time
 - EM 4 F-DO DC24V/2A PROFIsafe, D-4
 - EM 4/8 F-DI DC24V PROFIsafe, D-3
 - PM-D F DC24V PROFIsafe, D-2
 - PM-E F pm DC24V PROFIsafe, D-1
 - PM-E F pp DC24V PROFIsafe, D-2
- mechanical conditions
 - Test procedure, 6-13
- Mechanical conditions
 - Approved, 6-12
- Missing external auxiliary supply
 - EM 4 F-DO DC24V/2A PROFIsafe, 7-90
 - EM 4/8 F-DI DC24V PROFIsafe, 7-74
 - PM-D F DC24V PROFIsafe, 7-43
 - PM-E F pm DC24V PROFIsafe, 7-17
 - PM-E F pp DC24V PROFIsafe, 7-32
- Mixing standard and F-modules, 2-1
- Module diagnostics, 5-7
- Module failure
 - react to, 5-7
- Module Fault
 - diagnostic message, 5-7
- Module properties
 - Parameter Assignment, 2-8
- Module replacement
 - PROFIsafe address setting, 4-5
- Modules
 - fail-safe, 1-2
- Monitoring time
 - EM 4 F-DO DC24V/2A PROFIsafe, 7-88
 - EM 4/8 F-DI DC24V PROFIsafe, 7-51
 - PM-D F DC24V PROFIsafe, 7-42
 - PM-E F pm DC24V PROFIsafe, 7-15
 - PM-E F pp DC24V PROFIsafe, 7-31
- Mounting dimensions
 - F-modules, 3-4
- Mounting rails
 - applicable, 4-3

- N**
- NAMUR recommendations
 - requirements for power supply, 4-3
- Network failure
 - Requirements for override, 4-3
- Nominal line voltage, 6-14
- Number of modules
 - F-System with ET 200S, 2-6

- O**
- Optional package
 - S7 Distributed Safety, 2-8
 - S7 F Systems, 2-8
- Order numbers
 - of accessories, C-1
- output signals
 - Capacitive crosstalk, 7-7
- Overload, 5-6
 - EM 4 F-DO DC24V/2A PROFIsafe, 7-86, 7-90
 - PM-E F pm DC24V PROFIsafe, 7-13
- Override
 - At least with network failure, 4-3

Overtemperature, 5-6

- EM 4 F-DO DC24V/2A PROFIsafe, 7-90
- EM 4/8 F-DI DC24V PROFIsafe, 7-74
- PM-D F DC24V PROFIsafe, 7-43
- PM-E F pm DC24V PROFIsafe, 7-17
- PM-E F pp DC24V PROFIsafe, 7-32

P

Parameter

- EM 4 F-DO DC24V/2A PROFIsafe, 7-88
- EM 4/8 F-DI DC24V PROFIsafe, 7-51
- PM-D F DC24V PROFIsafe, 7-42
- PM-E F pm DC24V PROFIsafe, 7-15
- PM-E F pp DC24V PROFIsafe, 7-31

Parameter assignment

- F-modules, 2-8
- Module properties, 2-8
- The safety function, 1-4

Parameter assignment error, 5-6

- EM 4 F-DO DC24V/2A PROFIsafe, 7-90
- EM 4/8 F-DI DC24V PROFIsafe, 7-74
- PM-D F DC24V PROFIsafe, 7-43
- PM-E F pm DC24V PROFIsafe, 7-17
- PM-E F pp DC24V PROFIsafe, 7-32

Passivation, 5-2

PM-D F DC24V, 2-5

PM-D F DC24V PROFIsafe

- Block Diagram, 7-41
- Byte 7 of the diagnostic data, A-6
- Diagnostic Functions, 7-42, 7-43
- Fail-safe performance characteristics, 7-45
- Fault types, 5-6
- Faults and Remedies, 7-44
- Front View, 7-39
- Maximum response time, D-2
- Order Number, 7-37
- Parameters in STEP 7, 7-42
- Technical Specifications, 7-45
- terminal assignment, 7-40

PM-E 24 VDC, 2-5

PM-E DC24..48V, 2-5

PM-E DC24..48V/AC24..230V, 2-5

PM-E F 24 VDC PROFIsafe

- acknowledgment time, 7-46

PM-E F pm DC24V, 2-5

PM-E F pm DC24V PROFIsafe

- acknowledgment time, 7-23
- Block Diagram, 7-11
- Byte 7 of the diagnostic data, A-5
- Diagnostic functions, 7-17
- Fail-safe performance characteristics, 7-20
- Fault types, 5-6

Faults and Remedies, 7-18

- Front View, 7-8
- Maximum response time, D-1
- Order Number, 7-2
- Parameters in STEP 7, 7-15
- Readback Time, 7-15
- relay output, 7-12
- Technical Specifications, 7-20
- terminal assignment, 7-9
- Wiring Diagram, 7-12

PM-E F pp DC24V, 2-5

PM-E F pp DC24V PROFIsafe

- acknowledgment time, 7-36
- Block Diagram, 7-29
- Byte 7 of the diagnostic data, A-5
- Diagnostic Functions, 7-32
- Fail-safe performance characteristics, 7-34
- Fault types, 5-6
- Faults and Remedies, 7-33
- Front View, 7-27
- Installing the chassis cable, 7-25
- Maximum response time, D-2
- Order Number, 7-24
- Parameters in STEP 7, 7-31
- relay output, 7-30
- Technical Specifications, 7-34
- terminal assignment, 7-28
- Wiring Diagram, 7-30

Positioning

- power modules, 2-3

possible uses

- F-modules, 1-2

Power module

- fail-safe, 1-2
- positioning and connecting, 2-3
- Usable electronic modules, 2-5
- Usable motor starters, 2-5

Power supply

- Requirements, 4-3

Power supply of standard ET 200S module

- with power module, 7-4

Probability

- Dangerous faults, 4-6

Product

- Overview, 1-1

PROFIBUS

- Standard, 6-5

PROFIsafe, 1-2

- Address, 3-3, 4-5
- Address switch, 3-3
- Set address, 3-3

PROFIsafe Address Assignment

- rules, 3-4

- PROFIsafe address setting
 - when replacing a module, 4-5
 - Proof-Test Interval, 4-6, 7-54
 - for fail-safe performance characteristics, 7-1
 - Protection class, 6-14
 - Protective conductor bus, 2-3
 - P-Switch, 7-30
 - Pulse-shaped interference, 6-7
 - Purpose of this Manual, iii
 - PWR LED, 5-4
 - PM-D F DC24V PROFIsafe, 7-42
 - PM-E F pm DC24V PROFIsafe, 7-17
 - PM-E F pp DC24V PROFIsafe, 7-32
- R**
- Radio interference
 - emission of, 6-11
 - Readback Time
 - EM 4 F-DO DC24V/2A PROFIsafe, 7-88
 - PM-E F pm DC24V PROFIsafe, 7-15
 - Reading out
 - Diagnostic Functions, 5-7
 - Recycling, vi
 - Reduction
 - of vibrations, 6-12
 - Reintegration
 - Fail-Safe Module, 5-2
 - relay output
 - PM-E F pm DC24V PROFIsafe, 7-12
 - PM-E F pp DC24V PROFIsafe, 7-30
 - Relays, two
 - on one digital output, 7-86
 - Requirements
 - sensors and actuators, 4-6
 - Response time
 - Definition, D-1
 - F-Modules, D-1
- S**
- S7 Distributed Safety
 - example configuration, 1-3
 - Optional package, 1-4, 2-8
 - S7 F Systems
 - Optional package, 2-8
 - Safe functional extra low voltage, 4-2
 - Safe shutdown, 2-5
 - Safe state, 5-1
 - Safety class (AK)
 - achievable, 1-4
 - Safety function
 - Parameter Assignment, 1-4
 - Safety Integrity Level, 7-54
 - achievable, 1-4, 2-5
 - achieve with PM-E F pm DC24V PROFIsafe, 7-3
 - achieved with EM 4 F-DO DC24V/2A PROFIsafe, 7-80
 - Achieved with EM 4/8 F-DI DC24V PROFIsafe, 7-55
 - achieved with PM-D F DC24V PROFIsafe, 7-38
 - Achieving with EM 4/8 F-DI DC24V PROFIsafe, 7-47
 - Achieving with PM-E F pp DC24V PROFIsafe, 7-25
 - Safety Mode, 3-3
 - Safety-related shutdown, 5-6, 7-26
 - EM 4 F-DO DC24V/2A PROFIsafe, 7-90
 - PM-E F pm DC24V PROFIsafe, 7-17
 - PM-E F pp DC24V PROFIsafe, 7-32
 - Standard DO modules, 7-4
 - Saving faults, 5-1
 - Scope
 - Of this manual, iii
 - Sensor evaluation
 - EM 4/8 F-DI DC24V PROFIsafe, 7-60, 7-63, 7-67, 7-70, 7-72
 - Sensor Evaluation
 - EM 4/8 F-DI DC24V PROFIsafe, 7-51
 - EM 4/8 F-DI DC24V PROFIsafe, 7-57
 - Sensor interconnection
 - 1-channel, 7-51
 - 2-channel equivalent, 7-51
 - 2-channel, non-equivalent, 7-51, 7-71
 - EM 4/8 F-DI DC24V PROFIsafe, 7-51, 7-63, 7-67, 7-72
 - Sensor signal
 - Requirement for duration, 4-7
 - Sensor supply
 - EM 4/8 F-DI DC24V PROFIsafe, 7-58, 7-60, 7-69
 - Sensor Supply
 - EM 4/8 F-DI DC24V PROFIsafe, 7-56
 - EM 4/8 F-DI DC24V PROFIsafe, 7-57
 - internal, 7-52
 - Sensor voltage missing, 5-6
 - Sensors
 - externally supplied, 4-2
 - Requirements, 4-6
 - Service & Support
 - In the Internet, vii
 - setting
 - PROFIsafe address switch, 3-3

- SF LED, 5-4
 - EM 4 F-DO DC24V/2A PROFIsafe, 7-82
 - PM-D F DC24V PROFIsafe, 7-39
 - PM-E F pm DC24V PROFIsafe, 7-8
 - PM-E F pp DC24V PROFIsafe, 7-27
- SFC 13, 5-7
- SFCs
 - For Reading out Diagnostic Data, A-2
- Shielded cables, 7-51
- Shipbuilding approval, 6-5
- Short circuit
 - EM 4/8 F-DI DC24V PROFIsafe, 7-74
- Short circuit, 5-6
 - EM 4 F-DO DC24V/2A PROFIsafe, 7-90
 - EM 4/8 F-DI DC24V PROFIsafe, 7-60
 - EM 4/8 F-DI DC24V PROFIsafe, 7-57
 - on outputs of standard DO modules, 7-4, 7-26
 - PM-D F DC24V PROFIsafe, 7-43
 - PM-E F pm DC24V PROFIsafe, 7-17
 - PM-E F pp DC24V PROFIsafe, 7-32
- Short-circuit test
 - EM 4/8 F-DI DC24V PROFIsafe, 7-74
- Short-circuit test, 4-7, 5-4
 - EM 4/8 F-DI DC24V PROFIsafe, 7-51, 7-52, 7-60, 7-63, 7-67, 7-70, 7-72
 - EM 4/8 F-DI DC24V PROFIsafe, 7-57
- Shutdown
 - safe, 2-5
- SIMATIC product
 - Use in Industry, 6-5
- Sinusoidal interference, 6-10
- Slave Diagnostics, 5-4
 - Reading out, 5-7
- Standard DO modules
 - Safety-related shutdown, 7-4, 7-26
- Standard modules
 - Mixing with F-modules, 2-1
- Standards, 6-6
- state
 - safe, 5-1
- Storage conditions, 6-11
- Supply voltage, failure of
 - EM 4/8 F-DI DC24V PROFIsafe, 7-74
 - PM-D F DC24V PROFIsafe, 7-42
 - PM-E F pm DC24V PROFIsafe, 7-17
 - PM-E F pp DC24V PROFIsafe, 7-32
- Support, additional, vi
- Surge filter, 6-8

T

- Technical Specifications
 - EM 4 F-DO DC24V/2A PROFIsafe, 7-93
 - EM 4/8 F-DI DC24V PROFIsafe, 7-77
 - general, 6-1
 - PM-D F DC24V PROFIsafe, 7-45
 - PM-E F pm DC24V PROFIsafe, 7-20
 - PM-E F pp DC24V PROFIsafe, 7-34
- terminal assignment
 - EM 4/8 F-DI DC24V PROFIsafe, 7-49
 - PM-D F DC24V PROFIsafe, 7-40
 - PM-E F pm DC24V PROFIsafe, 7-9
 - PM-E F pp DC24V PROFIsafe, 7-28
- Terminal Modules, 4-4
- Terminal assignment
 - EM 4 F-DO DC24V/2A PROFIsafe, 7-83
- Terminal module, 7-40, 7-49
 - terminal assignment, 4-4
- Terminal module (dimensional diagram)
 - With F-module inserted, B-1
- Test voltages for insulation test, 6-14
- Test, mechanical
 - F-Modules, 6-13
- TM-E30C44-01, 7-49, 7-83
- TM-E30C46-A1, 7-49
- TM-E30S44-01, 7-49, 7-83
- TM-E30S46-A1, 7-49
- TM-P30C44-A0, 7-9
- TM-P30S44-A0, 7-9
- TM-PF30S47-F1, 7-40
- Total voltage
 - per voltage group, 2-7
- Total width
 - ET 200S, 2-6
- Training center, vi
- Transport and storage conditions, 6-11
- TÜV certificate, 6-6
- Two Relays
 - on one digital output, 7-13
- Type of protection IP20, 6-14

U

- UL approval, 6-2
- Use of ET 200S
 - In industry, 6-5
 - In residential areas, 6-5

V

Vibrations

- Reduction, 6-12

Voltage connection

- Additional, 2-3

Voltage Group

- Configuration example, 2-1

- Maximum configuration, 2-7

- new, 2-3

W

Wire break

- Detection with two relays on one digital output, 7-87

- EM 4 F-DO DC24V/2A PROFIsafe, 7-88, 7-90

- PM-E F pm DC24V PROFIsafe, 7-13, 7-15, 7-17

Wiring

- F-modules, 4-3

Wiring diagram

- EM 4/8 F-DI DC24V PROFIsafe, 7-59, 7-62, 7-65, 7-67, 7-70, 7-71, 7-72

Wiring Diagram

- EM 4 F-DO DC24V/2A PROFIsafe, 7-85

- EM 4/8 F-DI DC24V PROFIsafe, 7-56, 7-63

- PM-E F pm DC24V PROFIsafe, 7-12

- PM-E F pp DC24V PROFIsafe, 7-30



Siemens AG

A&D AS SM ID
Postfach 1963
D-92209 Amberg

Telefax: +49(9621)80-3103
<mailto:doku@ad.siemens.de>

Your Address:

Name:
Company:
Position:
Street:
Postal code / Place:
Email:
Phone:
Fax:

Your Feedback as regards the S7 Distributed Safety

Dear SIMATIC user,

Our goal is to provide you information with a high degree of quality and usability, and to continuously improve the SIMATIC documentation for you. To achieve this goal, we require your feedback and suggestions. Please take a few minutes to fill out this questionnaire and return it to me by Fax, e-mail or by post.

We are giving out three presents every month in a raffle among the senders. Which present would you like to have?

SIMATIC Manual Collection

Automation Value Card

Laser pointer

Dr. Thomas Rubach,
Head of Information & Documentation

General Questions	
<p>1. Are you familiar with the SIMATIC Manual Collection?</p> <p style="text-align: center;"><input type="checkbox"/> yes <input type="checkbox"/> no</p> <p>2. Have you ever downloaded manuals from the internet?</p> <p style="text-align: center;"><input type="checkbox"/> yes <input type="checkbox"/> no</p>	<p>3. Do you use Getting Starteds?</p> <p style="text-align: center;"><input type="checkbox"/> yes <input type="checkbox"/> no</p> <p>if yes, which:</p> <div style="border: 1px solid black; height: 50px; width: 100%;"></div> <p>4. How much experience do you have with the S7 Distributed Safety?</p> <p><input type="checkbox"/> Expert</p> <p><input type="checkbox"/> Experienced user</p> <p><input type="checkbox"/> Advanced user</p> <p><input type="checkbox"/> Beginner</p>

Please specify the documents, for which you want to answer the questions below:

A: Manual S7 Distributed Safety, Configuring and Programming

B: Manual S7-300, Fail-Safe Signal Modules

C: Manual ET 200S, Distributed I/O System Fail-Safe Modules

D: Manual ET 200eco, Distributed I/O Fail-Safe I/O Module

E: System Description Safety Engineering in SIMATIC S7

F: Getting Started S7 Distributed Safety

G: ET 200pro Distributed I/O Device - Fail-Safe Modules

1. In which project phase do you use this document frequently?

- | | |
|--|--|
| <input type="checkbox"/> Information | <input type="checkbox"/> Assembly |
| <input type="checkbox"/> Planning | <input type="checkbox"/> Commissioning |
| <input type="checkbox"/> Configuration | <input type="checkbox"/> Maintenance & Service |
| <input type="checkbox"/> Programming | <input type="checkbox"/> others: |

2. Finding the required information in the document:

How quickly can you find the desired information in the document?

- | | |
|---|--|
| <input type="checkbox"/> immediately | <input type="checkbox"/> not at all |
| <input type="checkbox"/> after a brief search | <input type="checkbox"/> after a long search |

Which search method do you prefer?

- | | |
|--|----------------------------------|
| <input type="checkbox"/> Table of contents | <input type="checkbox"/> Index |
| <input type="checkbox"/> Full-text search | <input type="checkbox"/> others: |

Which supplements/improvements would you like in order to help you find the required information quickly?

3. Your judgement of the document as regards content.

How satisfied are you with this document

- | | |
|--|---|
| <input type="checkbox"/> Totally satisfied | <input type="checkbox"/> not very satisfied |
| <input type="checkbox"/> Very satisfied | <input type="checkbox"/> not satisfied |
| <input type="checkbox"/> Satisfied | |

Were able to find the required information?

- yes no

which was not:

4. What is the scope of the information?

- Just right
 Not enough - which topic:

Too detailed – which topic:

5. Is the information easy to understand (texts, figures, tables)?

- yes no

if no, which was not:

6. Are examples important to you?

- no, of less importance
 yes, important – were the examples enough?

- yes no

if no, on which topic:

7. What are your suggestions as regards the contents of the document?

Thank you for your cooperation

ET 200S

Distributed I/O F Technology
Product Information for the
Distributed I/O System ET 200S,
Fail-Safe Systems Manual

Product information

Safety Guidelines

This manual contains notices you have to observe in order to ensure your personal safety, as well as to prevent damage to property. The notices referring to your personal safety are highlighted in the manual by a safety alert symbol, notices referring only to property damage have no safety alert symbol. These notices shown below are graded according to the degree of danger.



Danger

indicates that death or severe personal injury **will** result if proper precautions are not taken.



Warning

indicates that death or severe personal injury **may** result if proper precautions are not taken.



Caution

with a safety alert symbol, indicates that minor personal injury can result if proper precautions are not taken.

Caution

without a safety alert symbol, indicates that property damage can result if proper precautions are not taken.

Notice

indicates that an unintended result or situation can occur if the corresponding information is not taken into account.

If more than one degree of danger is present, the warning notice representing the highest degree of danger will be used. A notice warning of injury to persons with a safety alert symbol may also include a warning relating to property damage.

Qualified Personnel

The device/system may only be set up and used in conjunction with this documentation. Commissioning and operation of a device/system may only be performed by **qualified personnel**. Within the context of the safety notes in this documentation qualified persons are defined as persons who are authorized to commission, ground and label devices, systems and circuits in accordance with established safety practices and standards.

Prescribed Usage

Note the following:



Warning

This device may only be used for the applications described in the catalog or the technical description and only in connection with devices or components from other manufacturers which have been approved or recommended by Siemens. Correct, reliable operation of the product requires proper transport, storage, positioning and assembly as well as careful operation and maintenance.

Trademarks

All names identified by ® are registered trademarks of the Siemens AG. The remaining trademarks in this publication may be trademarks whose use by third parties for their own purposes could violate the rights of the owner.

Disclaimer of Liability

We have reviewed the contents of this publication to ensure consistency with the hardware and software described. Since variance cannot be precluded entirely, we cannot guarantee full consistency. However, the information in this publication is reviewed regularly and any necessary corrections are included in subsequent editions.

Table of contents

1	Introduction.....	1-1
2	Digital Electronics Module 1 F-RO DC24V/5A AC24..230V/5A.....	2-1
2.1	Properties of the EM 1 F-RO DC24V/5A AC24..230V/5A	2-1
2.2	Address assignment in the F-CPU.....	2-2
2.3	Terminal Assignment for EM 1F-RO DC24V/5A AC24..230V/5A.....	2-3
2.4	Wiring of the EM 1 F-RO DC24V/5A AC24..230V/5A.....	2-6
2.5	Diagnosis of the EM 1 F-RO DC24V/5A AC24..230V/5A.....	2-9
2.6	Technical Data of the EM 1 F-RO DC24V/5A AC24..230V/5A.....	2-9
2.7	Response Times of EM 1 F-RO DC24V/5A AC24..230V/5A.....	2-12
	Index.....	Index-1

Introduction

Scope

This product information supplements the manual *ET 200S, Fail-Safe Modules*, A5E00103686-04, Version 07/2005 and describes the new digital electronics module 1 F-RO DC24V/5A AC24..230V/5A.

Cross references in this product information

In order to simplify matters, all cross references to sections of the above-referenced manual are specified without giving the full name of the manual (e.g. "Refer to Chapter 5 in the Manual").

All cross references that do not reference a specific document are cross references to other parts of this product information (e.g., "see Section 2.7").

Order numbers

Component	Order number
1 F-RO DC24V/5A AC24..230V/5A	6ES7 138-4FR00-0AA0
Terminal module for 1 F-RO DC24V/5A AC24..230V/5A:	
TM-E30S44-01 (screw-in type), one item	6ES7 193-4CG20-0AA0
TM-E30C44-01 (snap-in type), one item	6ES7 193-4CG30-0AA0
TM-E30S46-A1 (screw-in type), one item	6ES7 193-4CF40-0AA0
TM-E30C46-A1 (snap-in type), one item	6ES7 193-4CF50-0AA0
Accessories	
DIN A4 label sheets, yellow, quantity of 10	6ES7 193-4BB00-0AA0

Digital Electronics Module 1 F-RO DC24V/ 5A AC24..230V/5A

2

2.1 Properties of the EM 1 F-RO DC24V/5A AC24..230V/5A

Order number

6ES7 138-4FR00-0AA0

Properties

The digital electronics module 1 F-RO DC24V/5A AC24..230V/5A has the following properties:

- 1 relay-output (2 make contact elements)
- 5 A output current
- Load nominal voltage DC 24 V und AC 24 ... 230 V
- Status display for each output (green LED)
- Attainable safety class SIL3, if the F-RO-Module is controlled through a fail-safe output (e.g. by EM 4F-DO DC24V/2A PROFIsafe)

2.2 Address assignment in the F-CPU

Address Assignment

The EM 1 F-RO DC24V/5A AC24..230V/5A is assigned to the following address areas in the F-CPU:

- For S7 Distributed Safety: in the area of the process image
- For S7 F/FH Systems: in the area of the process image

Table 2-1 Address assignment in the F-CPU

F-Module	Assigned bytes in the F-CPU:	
	In the input range	In the output range
1 F-RO DC24V/5A AC24..230V/5A	x.0 and x.1*	–
x = Module initial address		
* The bit addresses can be moved by carrying out the function "Pack addresses."		

Address assignment of user data

Of those addresses assigned in the EM 1 F-RO DC24V/5A AC24..230V/5A the user data is assigned to the following address in the F-CPU:

Table 2-2 Address assignment of user data

Byte in the F-CPU	Assigned bits in F-CPU for each F-Module:							
	7	6	5	4	3	2	1	0
1 F-RO DC24V/5A AC24..230V/5A								
x + 0	–	–	–	–	–	–	0	Channel 0
x = Module initial address								

2.3 Terminal Assignment for EM 1F-RO DC24V/5A AC24..230V/5A

Front View

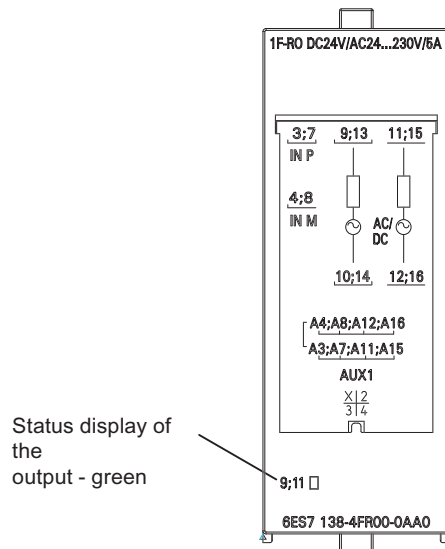

Figure 2-1 Front view EM 1 F-RO DC24V/5A AC24..230V/5A



Warning

The status display of the output may not be analyzed for activities dealing with safety.

Terminal assignment

The figure below depicts the terminal assignment of the EM 1 F-RO DC24V/5A AC24..230V/5A for the applicable terminal modules TM-E30S44-01, TM-E30C44-01, TM-E30S46-A1, and TM-E30C46-A1.

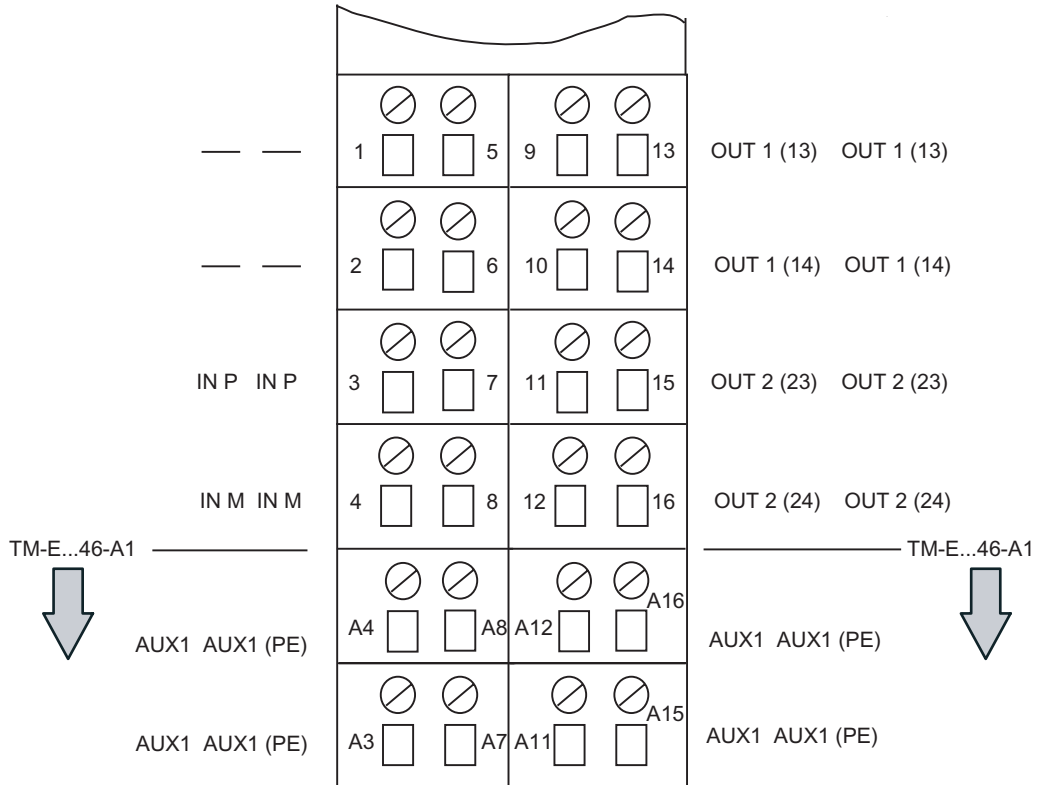

Figure 2-2 Terminal assignment TM-E...44-01/TM-E...46-A1 for EM 1 F-RO DC24V/5A AC24..230V/5A

Table 2-3 Terminal assignment of TM-P30S44-A0 and TM-P30C44-A0

Terminal		Designation
3	IN P	Terminal for control voltage DC 24V
4	IN M	Terminal for control voltage ground
A4	AUX 1	at TM-E...46-A1: AUX 1 bus implemented. Connection with the terminals A3 to A16 for any PE contact. Individual grouping of load current supply is possible.
A3	AUX 1	at TM-E...46-A1: AUX 1 bus implemented. Connection with the terminals A3 to A16 for any PE contact. Individual grouping of load current supply is possible.
7	IN P	Terminal for control voltage DC 24V
8	IN M	Terminal for control voltage ground
A8	AUX 1	at TM-E...46-A1: AUX 1 bus implemented. Connection with the terminals A3 to A16 for any PE contact. Individual grouping of load current supply is possible.
A7	AUX 1	at TM-E...46-A1: AUX 1 bus implemented. Connection with the terminals A3 to A16 for any PE contact. Individual grouping of load current supply is possible.
9	OUT 1 (13)	13, 14: Contacting element, channel 0 for fail-safe switching load 1
10	OUT 1 (14)	
11	OUT 2 (23)	23, 24: Contacting element, channel 1 for fail-safe switching load 2
12	OUT 2 (24)	
A12	AUX 1	at TM-E...46-A1: AUX 1 bus implemented. Connection with the terminals A3 to A16 for any PE contact. Individual grouping of load current supply is possible.
A11	AUX 1	at TM-E...46-A1: AUX 1 bus implemented. Connection with the terminals A3 to A16 for any PE contact. Individual grouping of load current supply is possible.
13	OUT 1 (13)	13, 14: Contacting element, channel 0 for fail-safe switching load 1
14	OUT 1 (14)	
15	OUT 2 (23)	23, 24: Contacting element, channel 1 for fail-safe switching load 2
16	OUT 2 (24)	
A16	AUX 1	at TM-E...46-A1: AUX 1 bus implemented. Connection with the terminals A3 to A16 for any PE contact. Individual grouping of load current supply is possible.
A15	AUX 1	at TM-E...46-A1: AUX 1 bus implemented. Connection with the terminals A3 to A16 for any PE contact. Individual grouping of load current supply is possible.



Caution

Parallel wiring must be carried out if high current is likely to occur on OUT 1 or OUT 2.

- for OUT 1: the terminals 9/10 and 13/14
- for OUT 2: the terminals 11/12 and 15/16

Otherwise, an overheating of the terminal caused by the current load cannot be ruled out.

2.4 Wiring of the EM 1 F-RO DC24V/5A AC24..230V/5A

Block diagram

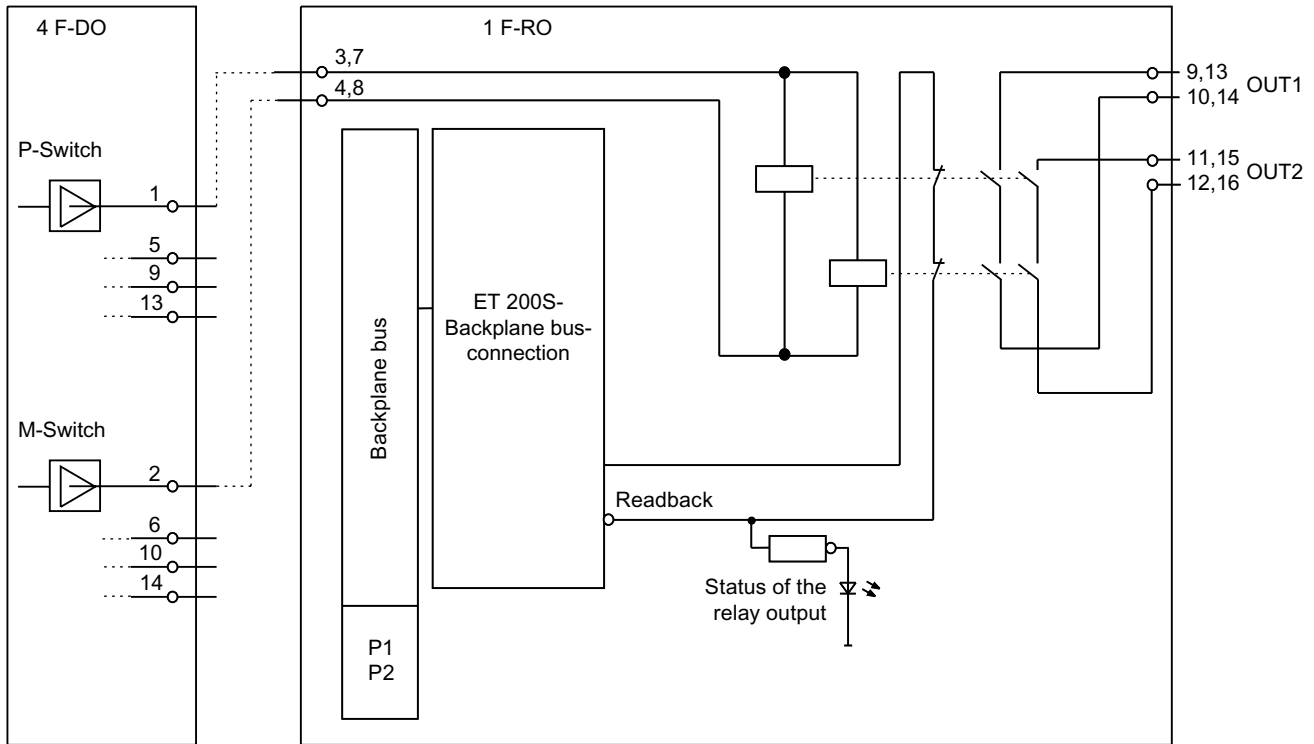

Figure 2-3 Block diagram of the EM 1 F-RO DC24V/5A AC24..230V/5A

Wiring diagram

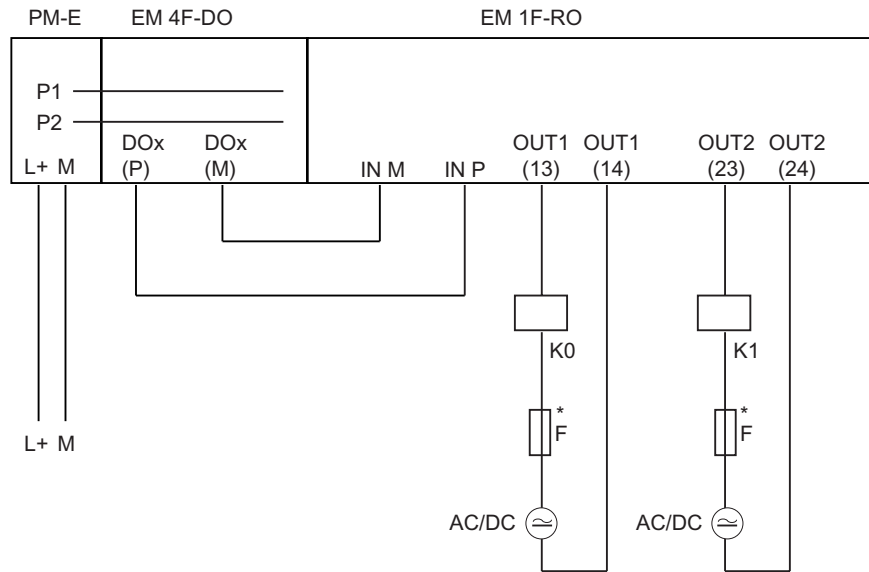

Figure 2-4 Wiring diagram of the EM 1 F-RO DC24V/5A AC24..230V/5A



Warning

* Please use an external fuse for the load current circuit with the following properties to protect the relay contacts from overload and short circuiting: Fusible cutout, 6 A of the operating class gL/gG

DC 24V-supply terminal

Connect the DC 24V control voltage to the IN P (terminals 3;7) and IN M (terminal 4;8). The DC 24V-supply normally takes place via a PM-switching fail-safe output (e.g. EM 4F-DO DC24V/2A PROFIsafe). For this purpose connect the P-output of the F-DO to the IN P of the F-RO module and the M-output to the IN M of the F-RO-module.

As an alternative it is possible to make the connection to a PP-switching fail-safe output. Please make sure that the external P connections on the P input cannot be controlled. In this case IN M would be connected directly to the control voltage ground.

Load voltage and load connection

The relay output connections are potential-free contacting elements. This means that the supply voltage must be provided externally. Connect the load supply (supply 1) and the load (load 1) in series on the connections OUT 1 (terminals 9;13)/(terminals10;14). This guarantees that the relay contacting elements interrupt the current flow of the load supply with the load. The power supply can still be disconnected with the two relay contacts connected in series in case on of the two relays is defective.

The second electric circuit is not electrically dependent on the first one. They are connected logically through their shared control. This means that the electric circuit from OUT 2 (terminal 11;15)/(terminals 12;16), supply 2 and load 2 can control a different potential.



Warning

If an extra low voltage (SELV/PELV) is connected to the channel of F-RO-module, than an extra low voltage (SELV/PELV) may only be connected on the other channel.

Relay contact readback

The readback value from F-RO-module must be compared with the control status in the safety program. For this purpose you can use the F-Systems S7 Distributed Safety F-application block FB 216 "F_FDBACK": feedback loop monitoring in your safety program (refer to the manual *S7 Distributed Safety, Configuration and Programming*).

In case the control voltage DC 24V falls below the required value for relay pick-up or the wire for input connections breaks, the relays will be released and "0" will be readback instead of "1." This error is only detected if the control voltage is switched on.

In case one of the two relays gets stuck (contacting element remains closed) then "1" is read back from the module. This readback value is compared with the expected value of "0" in the safety program and the error is detected. This error is only detected if the control voltage is switched on.

Note

In order to attain SIL3/Kat.4 a signal change is required at least once a day.

2.5 Diagnosis of the EM 1 F-RO DC24V/5A AC24..230V/5A

Output status display

The output status display on the F-RO-module has the following behavior:

- Relay not activated: LED does not light up
- Relay is activated: LED lights up
- Relay not activated and relay contact welded: LED lights up

Causes of Errors and Corrective Measures

For diagnostic purposes you can evaluate the F-Systems S7 Distributed Safety output "DIAG" des FB 216 "F_FDBACK," if you use this application block in your safety program for the readback of relay contacts (refer to the manual *S7 Distributed Safety, Configuration and Programming*).

2.6 Technical Data of the EM 1 F-RO DC24V/5A AC24..230V/5A

Overview

Technical Specifications	
Dimensions and Weight	
Dimensions W x H x D (mm)	30 x 81 x 52
Weight	Approx. 90 g
Module Specific Data	
Number of outputs	
• Relay outputs	1 (2 channels)
Assigned address area	
• In the I/O area for inputs	2 bits
• In the I/O area for outputs	--
Length of cable	
• unshielded for load contact	max. 200 m
• shielded for load contact	max. 200 m
• control cable (input)	max. 10 m
Maximum safety class attainable	
• according to IEC 61508	SIL3
• according to EN 954	Cat. 4
Safety parameters	SIL3
Low demand mode (average probability of failure on demand)	< 1.00E-05
High demand/continuous mode (probability of a dangerous failure per hour)	< 1.00E-09

Technical Specifications	
Voltages, Currents, Potentials	
Control voltage	DC 20.4 to 28.8 V (supply through F-DO fail-safe output)
Total current over both channels	
<ul style="list-style-type: none"> • Horizontal installation <ul style="list-style-type: none"> – up to 40 °C – up to 50 °C – up to 60 °C 	8 A 6 A 5 A at max. DC 24.8 V control voltage 3 A at max. DC 28.8 V control voltage
<ul style="list-style-type: none"> • Vertical installation <ul style="list-style-type: none"> – up to 40 °C 	6 A
Electrical isolation	
<ul style="list-style-type: none"> • Between channels and backplane bus 	yes
<ul style="list-style-type: none"> • Between channels and power supply 	yes
<ul style="list-style-type: none"> • Between channels 	yes
<ul style="list-style-type: none"> • Between channels/power supply and shield 	yes
Permissible potential difference between	
<ul style="list-style-type: none"> • Shield and ET 200S bus connection 	DC 75 V/AC 60 V
<ul style="list-style-type: none"> • Control voltage and shield 	DC 75 V/AC 60 V
<ul style="list-style-type: none"> • ET 200S bus connection and control voltage 	DC 75 V/AC 60 V
<ul style="list-style-type: none"> • Channel 1 and shield, ET 200S bus connection, control voltage, channel 2 	AC 250 V
<ul style="list-style-type: none"> • Channel 2 and shield, ET 200S bus connection, control voltage, channel 1 	AC 250 V
Isolation in the series tested with	
<ul style="list-style-type: none"> • Shield against ET 200S bus connection, control input, channel 1, channel 2 	DC 600 V/1 s
<ul style="list-style-type: none"> • Control input against ET 200S bus connection, shield, channel 1, channel 2 	DC 600 V/1 s
<ul style="list-style-type: none"> • ET 200S bus connection against control voltage, shield, channel 1, channel 2 	DC 600 V/1 s
<ul style="list-style-type: none"> • Channel 1 against shield, ET 200S bus connection, control voltage, channel 2 	DC 2545 V/1 s
<ul style="list-style-type: none"> • Channel 2 against shield, ET 200S bus connection, control voltage, channel 1 	DC 2545 V/1 s
Isolation in the type test tested with	
<ul style="list-style-type: none"> • Shield against ET 200S bus connection, control input, channel 1, channel 2 	AC 370 V/DC 520 V/1 min
<ul style="list-style-type: none"> • Control input against ET 200S bus connection, shield, channel 1, channel 2 	AC 370 V/DC 520 V/1 min
<ul style="list-style-type: none"> • ET 200S bus connection against control voltage, shield, channel 1, channel 2 	AC 370 V/DC 520 V/1 min
<ul style="list-style-type: none"> • Channel 1 against shield, ET 200S bus connection, control voltage, channel 2 	AC 2300 V/DC 3250 V/1 min
<ul style="list-style-type: none"> • Channel 2 against shield, ET 200S bus connection, control voltage, channel 1 	AC 2300 V/DC 3250 V/1 min

Technical Specifications	
Current consumption	
• From backplane bus	max. 10 mA
• From control voltage (IN P, IN M)	max. 100 mA
Power dissipation of the module	avg. 2.1 W
Status, Interrupts, Diagnostics	
Status display	green LED
Diagnostic Functions	
• Diagnostic information can be displayed	no
Data for Selecting an Actuator*	
Output current	
• Thermal constant current	max. 5 A
• Minimum load current	5 mA
Contact wiring (internal)	no
• On the relay outputs	no
Wire break monitoring	no
Parallel connection of 2 outputs	possible, no increase in load current
Digital input control	possible
Switching frequency	
• With resistive load	max. 2 Hz
• With inductive load according to IEC 947-5-1, DC13	max. 0.1 Hz
• With inductive load according to IEC 947-5-1, AC15	max. 2 Hz
Limitation (internal) of the voltage induced on the circuit interruption	no
Short-circuit protection of output	no, external fusible cutout 6 A operating class gL/gG
Time, Frequency	
Switching time	avg. 13 ms
Release time	avg. 16 ms
Protection against Overvoltage	
Protection of outputs from surge load in accordance with IEC 61000-4-5 (no protection elements required)	
• Symmetrical – Channel 1 (9/13) against (10/14) – Channel 2 (11/15) against (12/16)	+1 kV; 1.2/50 µs
• Unsymmetrical – Channel 1 (9/13) or (10/14) against PE – Channel 2 (11/15) or (12/16) against PE	+2 kV; 1.2/50 µs
*: For more information on the requirements for sensors and actuators see <i>"Wiring and Installing Modules."</i>	

Switching capacity and service life of the contacts

The following table indicates the switching capacity and service life of the contacts. Service life can be increased beyond the value indicated in the following table by using an external protective element.

Table 2-4 Switching capacity and service life of the contacts

Resistance load	Voltage	Current	Duty cycle (avg.) contacting element
For resistive load	DC 24 V	5.0 A	0.35 million
		3.0 A	0.5 million
		2.0 A	0.75 million
		1.0 A	1.8 million
		0.5 A	4 million
	AC 230 V	5.0 A	0.1 million
		3.0 A	0.15 million
		2.0 A	0.2 million
		1.0 A	0.4 million
		0.5 A	0.8 million
For inductive load according to IEC 947-5-1 DC 13/ AC15	DC 24 V	1.0 A	0.1 million
		0.5 A	0.2 million
	AC 230 V	1.0 A	0.2 million
		0.5 A	0.35 million

2.7 Response Times of EM 1 F-RO DC24V/5A AC24..230V/5A

Maximum response times of EM 1 F-RO DC24V/5A AC24..230V/5A

The maximum response time of EM 1 F-RO DC24V/5A AC24..230V/5A (under error free circumstances and during the presence of errors) is the sum of:

- The maximum response time of the fail-safe output, used for activating the F-RO-module (e.g. EM 4F-DO DC24V/2A PROFIsafe; refer to the manual, Appendix D) and
- The switching time or the relay release time of the F-RO-module (refer to the Technical Specifications, Chapter 2.6).

Index

A

- Accessories
 - Order numbers, 1-1
- Address Assignment
 - F-modules in F-CPU, 2-2
 - User data in F-CPU, 2-2

E

- EM 1 F-RO DC24V/5A AC24..230V/5A
 - Order number, 2-1
 - Safety parameters, 2-9
 - Technical Specifications, 2-9
 - Terminal assignment, 2-4

F

- F-CPU
 - Address assignment of user data, 2-2
- F-modules
 - Address assignment in F-CPU, 2-2

M

- Maximum response time
 - EM 1 F-RO DC24V/5A AC24..230V/5A, 2-12

O

- Order numbers
 - of accessories, 1-1
- Output
 - Status display, 2-9

S

- Safety parameters
 - EM 1 F-RO DC24V/5A AC24..230V/5A, 2-9
- Status display
 - Output, 2-9

T

- Technical Specifications
 - EM 1 F-RO DC24V/5A AC24..230V/5A, 2-9
- Terminal assignment
 - EM 1 F-RO DC24V/5A AC24..230V/5A, 2-4
 - TM-E30C44-01, 2-4
 - TM-E30S44-01, 2-4

