

SIEMENS

SIMATIC

Bus links PN/PN coupler

Installation and Operating Manual

Preface	
Description	1
Assembling	2
Connecting	3
Configuring and commissioning	4
Data record transfer from one IO Controller to another IO Controller	5
Operating	6
Diagnostics	7
Technical data	A
Order numbers and accessories	B
Dimensional drawings	C

Legal information

Warning notice system

This manual contains notices you have to observe in order to ensure your personal safety, as well as to prevent damage to property. The notices referring to your personal safety are highlighted in the manual by a safety alert symbol, notices referring only to property damage have no safety alert symbol. These notices shown below are graded according to the degree of danger.

⚠ DANGER
indicates that death or severe personal injury will result if proper precautions are not taken.
⚠ WARNING
indicates that death or severe personal injury may result if proper precautions are not taken.
⚠ CAUTION
with a safety alert symbol, indicates that minor personal injury can result if proper precautions are not taken.
CAUTION
without a safety alert symbol, indicates that property damage can result if proper precautions are not taken.
NOTICE
indicates that an unintended result or situation can occur if the corresponding information is not taken into account.

If more than one degree of danger is present, the warning notice representing the highest degree of danger will be used. A notice warning of injury to persons with a safety alert symbol may also include a warning relating to property damage.

Qualified Personnel

The device/system may only be set up and used in conjunction with this documentation. Commissioning and operation of a device/system may only be performed by **qualified personnel**. Within the context of the safety notes in this documentation qualified persons are defined as persons who are authorized to commission, ground and label devices, systems and circuits in accordance with established safety practices and standards.

Proper use of Siemens products

Note the following:

⚠ WARNING
Siemens products may only be used for the applications described in the catalog and in the relevant technical documentation. If products and components from other manufacturers are used, these must be recommended or approved by Siemens. Proper transport, storage, installation, assembly, commissioning, operation and maintenance are required to ensure that the products operate safely and without any problems. The permissible ambient conditions must be adhered to. The information in the relevant documentation must be observed.

Trademarks

All names identified by ® are registered trademarks of the Siemens AG. The remaining trademarks in this publication may be trademarks whose use by third parties for their own purposes could violate the rights of the owner.

Disclaimer of Liability

We have reviewed the contents of this publication to ensure consistency with the hardware and software described. Since variance cannot be precluded entirely, we cannot guarantee full consistency. However, the information in this publication is reviewed regularly and any necessary corrections are included in subsequent editions.

Preface

Purpose of manual

This manual provides you with all the information you need to configure, assemble, connect and commission the PN/PN coupler.

Basic knowledge required

The following knowledge is required in order to understand the manual:

- general knowledge in the area of automation technology
- You will also need to know how to use computers or PC-like equipment (such as programming devices) under Windows operating systems.
- Knowledge of working with *STEP 7*. This is provided in the Programming with STEP 7 V5.4 (<http://support.automation.siemens.com/WW/view/en/18652056>) manual.

Scope of manual

The manual applies to the PN/PN coupler with order number 6ES7158-3AD01-0XA0.

This manual contains a description of the components which were valid at the time the manual was published. We reserve the right to include product information with information updates for new components and components with a new product status.

Changes compared to the previous version

The following changes have been made to the PN/PN Coupler Bus Links (<http://support.automation.siemens.com/WW/view/en/23865436>) Manual compared to the previous version (08/2006 edition):

The PN/PN coupler has the following features:

- Isochronous real-time communication
- Prioritized startup
- Device replacement without removable medium/programming device
- Data record transfer from one IO Controller to another
- LED for maintenance demand (maintenance)

In addition, the product information published in 03/2007 has been integrated in the manual.

Approvals

See Appendix General technical data (Page 70)

CE mark

See Appendix General technical data (Page 70)

Identification for Australia (C-Tick mark)

See Appendix General technical data (Page 70)

Standards

See Appendix General technical data (Page 70)

Classification in information landscape

Depending on the hardware used, you will need the following manuals in addition to this one:

- the manual for the IO Controller used. The following details in this manual apply in particular:
 - Configuring and commissioning of a PROFINET IO system
 - Description of the IO Controller
- PROFINET System Description (<http://support.automation.siemens.com/WW/view/en/19292127>) Manual
- From PROFIBUS DP to PROFINET IO (<http://support.automation.siemens.com/WW/view/en/19289930>) Programming Manual

Guide

The manual is based on the following subject areas:

- Product overview and description of the PN/PN coupler
- Assembly, connection and commissioning
- Operation and diagnostics
- Appendices

Important terms are explained in the glossary. The index helps you to quickly find all texts relevant to your keyword.

Recycling and disposal

Given its environmentally-compatible equipment, the PN/PN coupler can be recycled. Contact a company certified in the disposal of electronic waste to ensure the environmentally-compatible recycling and disposal of your used device.

Contacts

See Industrial Automation Systems SIMATIC, SIMATIC NET Technical Support, Contacts and Training (<http://support.automation.siemens.com/WW/view/en/19293011>) Product Information

Training

See Industrial Automation Systems SIMATIC, SIMATIC NET Technical Support, Contacts and Training (<http://support.automation.siemens.com/WW/view/en/19293011>) Product Information

Technical support

See Industrial Automation Systems SIMATIC, SIMATIC NET Technical Support, Contacts and Training (<http://support.automation.siemens.com/WW/view/en/19293011>) Product Information

Service & Support on the Internet

See Industrial Automation Systems SIMATIC, SIMATIC NET Technical Support, Contacts and Training (<http://support.automation.siemens.com/WW/view/en/19293011>) Product Information

Table of contents

	Preface	3
1	Description	9
1.1	Application and function.....	9
1.2	View	12
1.3	Properties.....	13
2	Assembling	15
2.1	Assembly rules.....	15
2.2	Assembling the PN/PN coupler.....	16
2.3	Disassembling the PN/PN coupler.....	16
2.4	Assembling-color plates.....	17
3	Connecting	19
3.1	Electrical isolation and grounding	19
3.1.1	Introduction	19
3.1.2	General operating rules and regulations.....	20
3.2	Connections	22
3.3	Connecting the power supply.....	23
3.4	Connecting PROFINET IO.....	25
4	Configuring and commissioning	27
4.1	Configuring and commissioning of the PN/PN coupler (overview)	27
4.2	Configuring the PN/PN coupler with STEP 7	28
4.2.1	Requirements.....	28
4.2.2	Configuring the PN/PN coupler with STEP 7.....	28
4.2.3	Example: Configuration of the inputs/outputs of the PN/PN coupler with STEP 7	31
4.3	Configuration of the PN/PN coupler with another configuring tool	33
4.4	Parameters.....	34
4.5	Isochronous real-time communication	35
4.6	Prioritized startup	35
4.7	Device replacement without removable medium/programming device	36
4.8	SNMP	37
4.9	Commissioning the PN/PN coupler	38
5	Data record transfer from one IO Controller to another IO Controller	39

6	Operating	45
6.1	Response times of the PN/PN coupler	45
6.2	SIMATIC Micro Memory Card	46
6.3	Updating firmware	47
6.3.1	Updating firmware using SIMATIC Micro Memory Card	48
6.4	Replacing defective PN/PN coupler	49
6.5	Identification data	50
7	Diagnostics	53
7.1	Diagnostics via LED displays	53
7.2	Diagnostics by user program	57
7.2.1	Manufacturer-specific diagnostics	57
7.2.2	Interrupts	58
7.2.3	Diagnostics readout	60
7.2.4	Example of diagnostics	62
7.2.5	Data validity display	68
7.2.6	Evaluation of the useful data flag	68
7.2.7	STOP of the IO controller and recovery of the IO device	68
A	Technical data	69
A.1	Technical data for PN/PN coupler (6ES7158-3AD01-0XA0)	69
A.2	General technical data	70
A.2.1	Introduction	70
A.2.2	Standards and approvals	71
A.2.3	Electromagnetic compatibility	73
A.2.4	Transport and storage conditions	75
A.2.5	Mechanical and climatic ambient conditions for operation	76
A.2.6	Specifications for insulation tests, safety class and degree of protection	78
A.2.7	Rated voltage	78
B	Order numbers and accessories	79
B.1	Order numbers and accessories	79
C	Dimensional drawings	81
C.1	PN/PN coupler dimensional drawing	81
	Glossary	83
	Index	91

Description

1.1 Application and function

Application and principle of operation

The PN/PN coupler is used to link two Ethernet subnets with one another and to exchange data. The maximum size of the data which can be transferred is 256-byte input data and 256-byte output data.

As a device, the PN/PN coupler has two PROFINET interfaces, each of which is linked to one subnet.

During configuring, two IO Devices are produced from this one PN/PN coupler which means that there is one IO Device for each station with its own subnet. The other part of PN/PN coupler in each case is known as the bus node. Once configuring is complete, the two parts are joined.

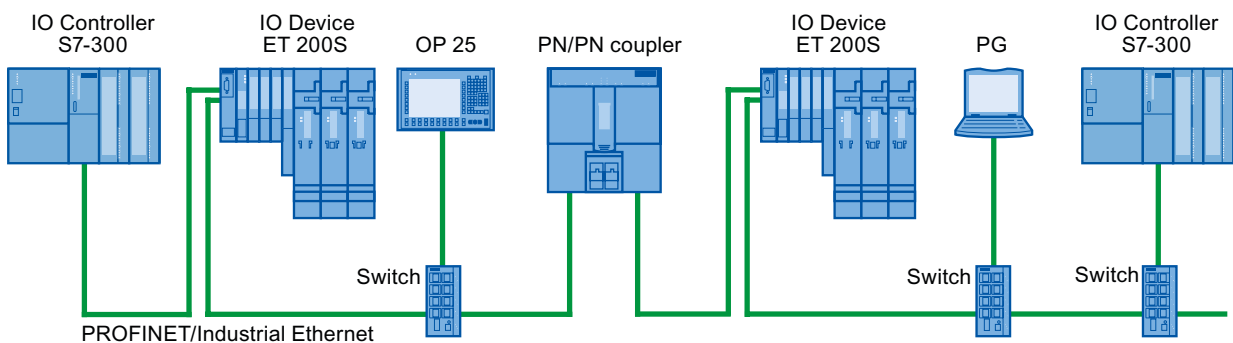

Figure 1-1 Coupling two PROFINET subnets with one PN/PN coupler

Application examples for cyclic I/O data exchange between IO Controllers via a PN/PN coupler

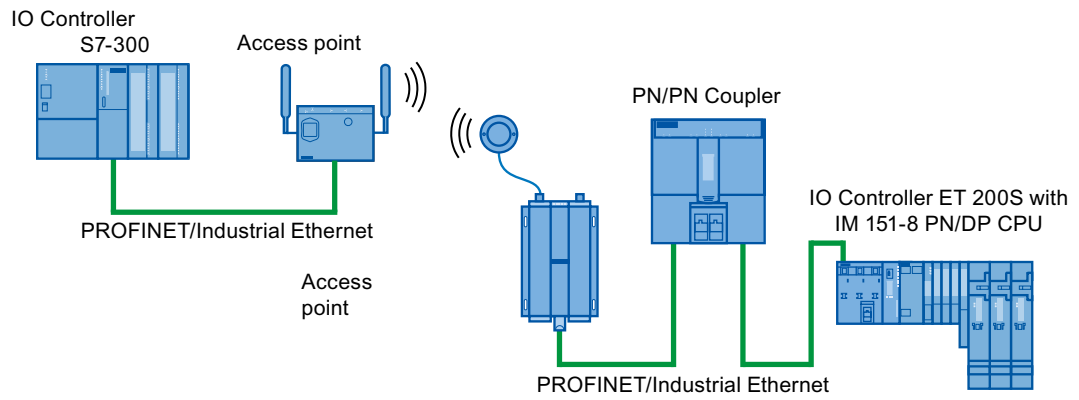

Figure 1-2 Cyclic data exchange between two I/O Controllers via IWLAN

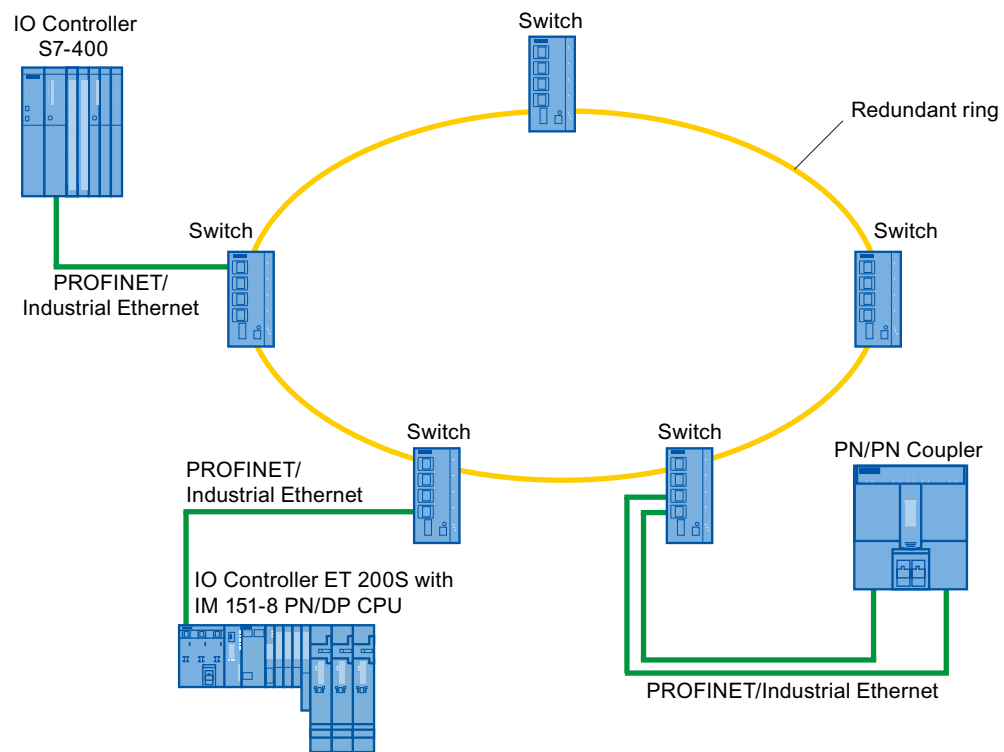

Figure 1-3 Cyclic data exchange between two I/O Controllers via a redundant ring

Configuring

You either configure the PN/PN coupler using STEP 7 or a configuring tool which uses a GSD file to integrate the PN/PN coupler.

You choose the modules for the PN/PN coupler required for your application in the hardware catalog of HW Config in STEP 7. The output data of one side of the PN/PN coupler is transferred as the input data of the other side and vice versa.

You configure the I/O areas using virtual modules that are inserted from the hardware catalog in HW Config onto slots of the PN/PN coupler, the same as real modules. The modules span an I/O area over which data is exchanged between the two PROFINET subnets. The local CPU uses a slot's configured inputs to read the values which the CPU of the other subnet writes using the bus node's configured outputs. The local CPU uses a slot's configured outputs to write values which the CPU of the other subnet receives using the bus node's configured inputs.

Example

The following example shows that both networks are independent of one another. In other words, they issue a unique device name for each PROFINET IO network.

In the following picture, you can see device name "Subnet1" in network 1 and "Subnet2" in network 2.

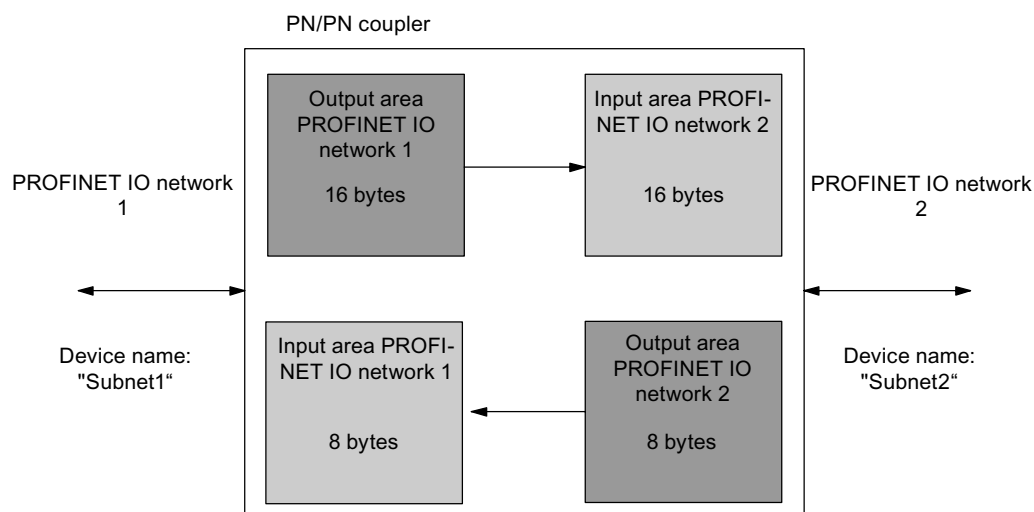
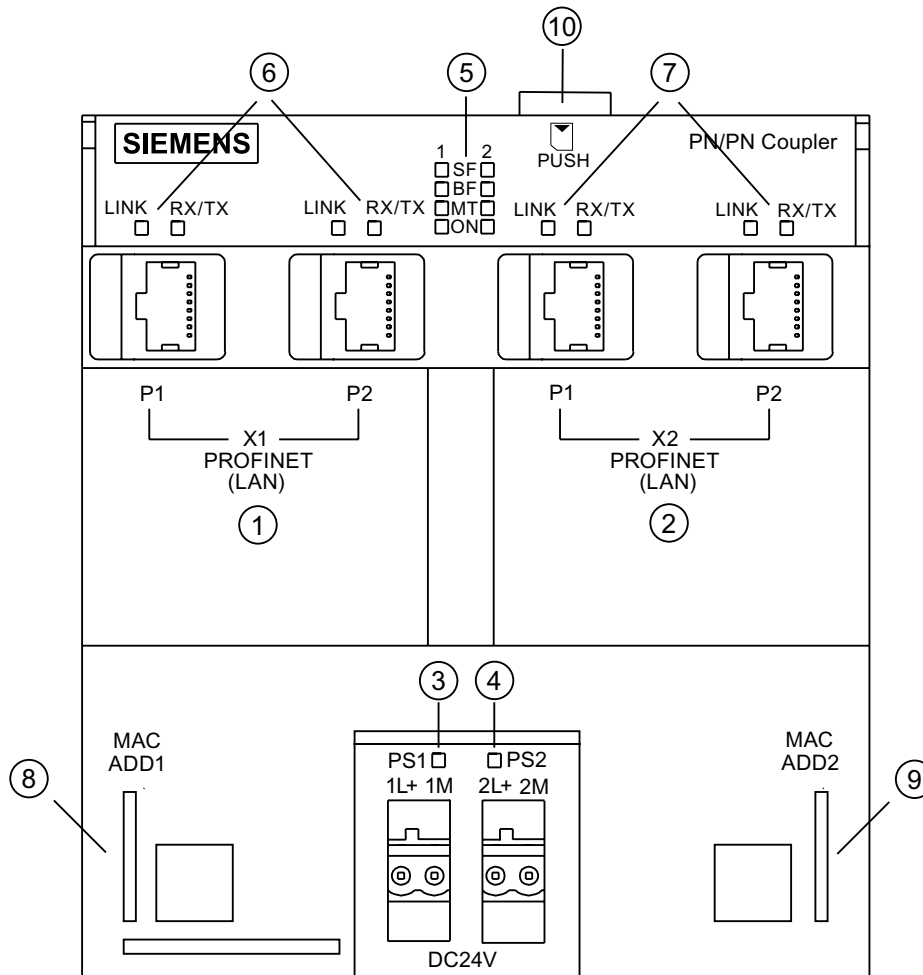

Figure 1-4 Main FC of the PN/PN coupler (example)

1.2 View

View

The following picture shows the PN/PN coupler and its display elements:



- | | |
|------------------------------------------------------------|---------------------------------------------|
| ① PROFINET IO interfaces for subnet 1 (X1) | ⑥ Status LEDs for PROFINET IO subnet 1 (X1) |
| ② PROFINET IO interfaces for subnet 2 (X2) | ⑦ Status LEDs for PROFINET IO subnet 2 (X2) |
| ③ Connection of power supply 1 with status LED | ⑧ MAC address for PROFINET IO subnet 1 (X1) |
| ④ Connection of power supply 2 with status LED | ⑨ MAC address for PROFINET IO subnet 2 (X2) |
| ⑤ Diagnostics LEDs for PROFINET IO subnet 1 and 2 (X1, X2) | ⑩ Slot for SIMATIC Micro Memory Card |

Figure 1-5 Display elements and interfaces of the PN/PN coupler

1.3 Properties

Properties

The PN/PN coupler has the following properties:

- Maximum data exchange of 256-bytes input data and 256-byte output data
- Maximum of 16 input/output ranges for the exchange of data
- Electrical isolation between the two PROFINET IO subnets
- Redundant power supply
- Supported Ethernet services
 - ping
 - arp
 - Net diagnostics (SNMP) / MIB-2
- Diagnostic interrupts
- ReturnOfSubmodule interrupts
- Isochronous real-time communication
- Prioritized startup
- Device replacement without removable medium/programming device
- Data record transfer from one IO Controller to another

Description

1.3 Properties

Assembling

2.1 Assembly rules

Mounting position

You can mount the PN/PN coupler in any position. Please note that the maximum ambient temperature for horizontal mounting positions is 60 °C while that for all other positions is 40 °C.

You will find more information on operating conditions in Appendix Technical data (Page 69).

Open component

The PN/PN coupler is an open component. In other words, you may only set it up in enclosures, cabinets or electrical service rooms. These should only be accessible by means of a key or a special tool. Only trained or authorized personnel may have access to the enclosures, cabinets or electrical service rooms.

Technical setup

Mount the PN/PN coupler on a DIN rail (7.5 mm and 15 mm). Ensure a space of 40 mm both above and below the module for unimpeded assembly.

2.2 Assembling the PN/PN coupler

Components required

- PN/PN coupler
- Mounting rail:
 - DIN rail (7.5 mm) or
 - DIN rail (15 mm)

The order numbers for the components can be found in Appendix Order numbers and accessories (Page 79).

Assembling PN/PN coupler on DIN rail

1. Assemble the DIN rail such that there is enough space to assemble and heat the modules (at least 40 mm above and below the modules). If you want to swap the SIMATIC Micro Memory Card once the PN/PN coupler is assembled, you will have to leave additional space for this.
2. Fit the PN/PN coupler in the DIN rail and swing it down.
3. Wire the PN/PN coupler as described in Chapter Connecting (Page 19).

Note

If the assembly base is a grounded metal plate or a grounded equipment mounting plate, then you must ensure a low-ohm connection between the DIN rail and base. E.g. with painted or anodized metals, use a suitable contacting agent or contact washers.

2.3 Disassembling the PN/PN coupler

Disassembling the PN/PN coupler

1. Switch off the PN/PN coupler's power supply.
2. Loosen the connections and bus connectors on the PN/PN coupler.
3. Use a screwdriver to push down the slide valve on the underneath of the PN/PN coupler.
4. With the slide valve still pressed down, swing the PN/PN coupler out of the mounting rail.

2.4 Assembling-color plates

Introduction

The color-coding plates allow you to individually color code the PROFINET IO interfaces in accordance with company and national regulations. The color-coding plates are available in white, red, yellow, yellow-green, brown, blue and turquoise. You can provide every PROFINET IO interface on the PN/PN coupler with a color-coding plate.

The color-coding plates are positioned on the bottom right of each PROFINET IO interface.

Required tool

Screwdriver 3.5 mm blade width

Assembling color-coding plates

1. Use the screwdriver to push the spigot of the color-coding plate into the opening provided for this in the PN/PN coupler.
2. Secure the color-coding plate as described below.
3. Bend the star-shaped support up by approx. 30° to 40°.
4. Detach the color-coding plate by moving the support this way and that.

Disassembling color-coding plates

Use a screwdriver to lever the color-coding plates from their supports.

See also

Order numbers and accessories (Page 79)

Connecting

3.1 Electrical isolation and grounding

3.1.1 Introduction

Redundant 24 V DC power supply

You can connect the PN/PN coupler to two independent 24 V DC power supplies. Only one 24 V DC power supply is ever active at any one time. If one power supply fails, the other automatically becomes active. During parameterization, you identify which power supplies (PS1, PS2 or both) are connected and are to be diagnosed. You need only connect up one 24 V DC power supply to operate the PN/PN coupler.

Properties of the PN/PN coupler

- Both PROFINET IO subnets are electrically isolated from one another.
- Both PROFINET IO subnets are electrically isolated from the 24 V DC power supply.
- Both 24 V DC power supplies are electrically isolated from one another.
- The PROFINET IO subnet to X1 and the logic of the PN/PN coupler are electrically linked.

Ungrounded incoming supply

Non-grounded operation of the PN/PN coupler is possible with a 24 V DC power supply.

See also

Parameters (Page 34)

3.1.2 General operating rules and regulations

Introduction

If they are part of plants or systems the modules described require adherence to specific rules and regulations depending on the application.

The most important rules, which you must observe for safe integration into a plant or system, are listed below.

Specific application

Please observe the safety and accident prevention regulations applying to specific applications (e.g. machine protection guidelines).

EMERGENCY STOP equipment

EMERGENCY STOP devices according to IEC 6204 (coincides with VDE 113) must remain effective during all operating modes of the plant or system.

System startup after certain events

The table below identifies situations you must pay attention to when the system starts up after the occurrence of certain events.

When
<ul style="list-style-type: none">starting up after a voltage dip or power failure,starting up after bus communication has been interrupted,	no dangerous operating states may occur. If necessary actuate an EMERGENCY-STOP!
<ul style="list-style-type: none">starting up after unlocking the emergency stop device,starting up without the IO Controller activating the IO Devices,	the start up must always be controlled and defined.

24 V DC power supply

The table below identifies to what you must pay attention for the 24V supply.

When ...	Requirements ...	
Buildings	External lightning protection	Provide lightning protection (e.g. lightning protection units)
24 V DC supply lines, signal lines	Internal lightning protection	
24V supply	Safety extra-low voltage (SELV) with guaranteed electrical isolation.	

Note

For information about lightning protection, refer to the S7-300 Automation System, Hardware and Installation: CPU 312 IFM – 318-2 DP

(<http://support.automation.siemens.com/WW/view/en/15390415>) Installation Manual.

Protection from external electrical impacts

The table below identifies to what you must pay attention when protecting against electrical impacts or errors.

When ...	ensure that ...
all plants or systems in which the modules are integrated	... the plant or system is connected to the protective conductor so that the electromagnetic interference is discharged.
Connecting leads, signal and bus lines	... the arrangement of the wiring and installation are correct

3.2 Connections

Connections of the PN/PN coupler

The following picture shows you all the connections you can make to and from the PN/PN coupler:

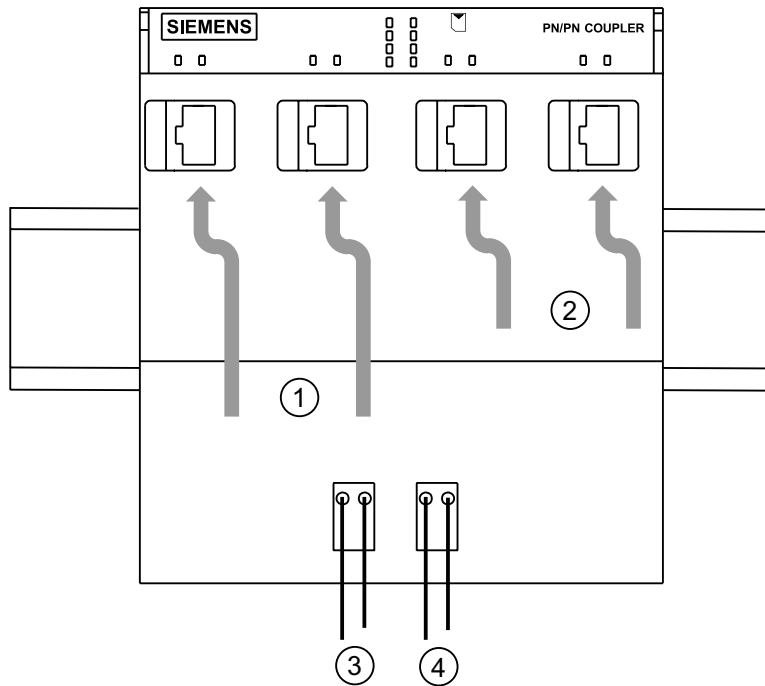

- | | | | |
|---|---------------------------|---|--------------------------|
| ① | PROFINET IO subnet 1 (X1) | ③ | Power supply 1 (24 V DC) |
| ② | PROFINET IO subnet 2 (X2) | ④ | Power supply 2 (24 V DC) |

Figure 3-1 Connections of the PN/PN coupler

3.3 Connecting the power supply

Required tool

In order to connect the power supply, you will need a screwdriver with a 3 mm blade width.

Power supply unit

You may only use PELV-type power supply units with a guaranteed electrically isolated extra-low voltage (≤ 60 VDC).

Redundant power supply

You can supply the PN/PN coupler from two voltage sources (redundant power supply):

- If one voltage source fails, the PN/PN coupler automatically changes over to the other voltage source.
- If both connections (PS1 / PS2) are energized, the PN/PN coupler will automatically use the PS1 voltage source.
- If you only connect the PN/PN coupler to one power supply, you should preferably use PS1.

Note

You can use the diagnostics to assess whether the PN/PN coupler is connected to both 24 V DC power supplies.

Connection for power supply

The power supply connections for the 24V power supply are located at the front of the PN/PN coupler. The connections have the following functions:

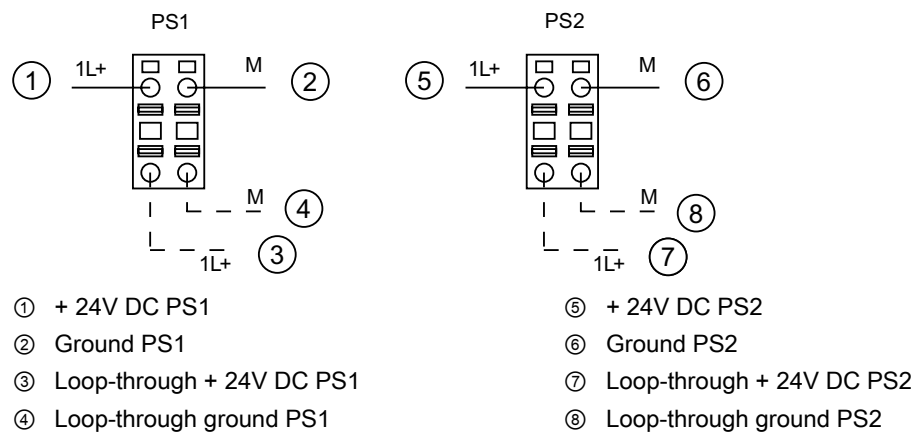

Figure 3-2 Power supply for the PN/PN coupler

The maximum cross-section of the connection is 2.5 mm². There is no strain relief. The connecting plug allows you to loop on the power supply with no interrupts even when removed.

Procedure

1. Strip the wires to a length of 10 mm.
2. Insert line into round opening on connecting plug until stop is reached. (In its delivery condition, the connecting plug is plugged into the power supply connection.)

If you have a redundant PN/PN coupler power supply, connect a second power supply to the second connecting plug.

If you only use one voltage source, you should preferably use PS1.

3. Plug the wired connecting plug(s) on to the power supply connection on the PN/PN coupler.

3.4 Connecting PROFINET IO

Requirements

- See also the information in Chapter General operating rules and regulations (Page 20).

Required tool

- Screwdriver with 2.5 mm
- Industrial Ethernet Fast Connect stripping tool (6GK1 901-1GA00) (stripping tool for Industrial Ethernet Fast Connect installation cables)

Connecting cable and connecting plug

Use only the accessories specified in Appendix Order numbers and accessories (Page 79) for PROFINET IO..

Required accessories

- PROFINET connector according to the specifications in PROFINET Installation Guide (<http://www.profinet.com/pall/meta/downloads/>).
- Industrial Ethernet Fast Connect installation cables

The following are suitable:

Fast Connect standard cable	6XV1840-2AH10
Fast Connect trailing cable	6XV1840-3AH10
Fast Connect marine cable	6XV1840-4AH10

Assembling a bus connector

Assemble the PROFINET connector according to the information in PROFINET Installation Guide (<http://www.profinet.com/pall/meta/downloads/>).

Procedure

1. Insert the bus connector into the PROFINET connection.
2. If required, use cable ties to secure the cables to the PN/PN coupler enclosure.
3. Close the PN/PN coupler flap.

Configuring and commissioning

4.1 Configuring and commissioning of the PN/PN coupler (overview)

Overview

The table below identifies the steps required for commissioning.

Table 4- 1 Procedure for PN/PN coupler configuration and commissioning

Step	Activity	Content	More information in chapter
1	Assembling	Assemble the PN/PN coupler on the mounting rail.	Assembling (Page 15)
2	Connecting	Connect PN/PN coupler to power supply and PROFINET IO.	Connecting (Page 19)
3	Configuring the PN/PN coupler	<ul style="list-style-type: none"> With STEP 7 	Configuring the PN/PN coupler with STEP 7 (Page 28)
		<ul style="list-style-type: none"> With another configuring tool 	Configuration of the PN/PN coupler with another configuring tool (Page 33)
4	Parameterization	Parameterize the PN/PN coupler in STEP 7 or with another configuration tool.	Parameters (Page 34) and STEP 7 Online Help
5	Commissioning the PN/PN coupler	Switch on PN/PN coupler and load configuration.	Commissioning the PN/PN coupler (Page 38)

4.2 Configuring the PN/PN coupler with STEP 7

4.2.1 Requirements

Requirements

To configure the PN/PN coupler, you will need:

- STEP 7 Version 5.4 or higher, Service Pack 5

4.2.2 Configuring the PN/PN coupler with STEP 7

Introduction

For standard mode, you configure the PN/PN coupler with STEP 7. Once you have configured both subnets in a project or multiproject, STEP 7 will assist you with the correct configuration. If you have split the two subnets into two STEP 7 projects, you will have to configure the PN/PN coupler separately in each of the two projects.

NOTICE
Note the following requirements for coupling the two subnets: <ul style="list-style-type: none">• A "RD READ" output module/module of the same length must be configured at the same slot in another subnet for each "RD WRITE" input module/module in a subnet.• A "RD WRITE" input module/module of the same length must be configured at the same slot in another subnet for each "RD READ" output module/module in a subnet.

Configuring the PN/PN coupler

1. Start STEP 7 with your project and open the HW configuration.
2. From the hardware catalog, directory PROFINET IO\Gateway\PN/PN Coupler\PN/PN Coupler V2.0, drag the PN/PN coupler X1 to the PROFINET network.
3. Double-click on the PN/PN coupler symbol.
4. Give the PN/PN coupler a device name and confirm by clicking on "OK".

This device name must be unique on the Ethernet subnet. The device name must satisfy the DNS conventions. You will find more information about issuing device names in the online help for STEP 7.
5. To configure the left end of the bus (X1), click the PN/PN coupler symbol.

The PN/PN coupler's 16 slots appear in the station window in the bottom section of HW configuration.
6. Start by assigning a module from the "PN/PN Coupler V2.0 / PN/PN Coupler X1" folder in the hardware catalog in HW Config to the slots, starting with slot 1.
7. In the "Addresses" tab of the module, select the start addresses of the inputs and outputs.
8. Confirm your entries by clicking on "OK".

Note

In order to operate the PN/PN coupler, the left bus end (X1) and right bus end (X2) must always be separately configured and these may also be located in different projects. Make sure that you have loaded the configuration to the correct end of the bus, X1 and X2, in each case. Configuration with an incorrect assignment will be rejected by the bus end of the PN/PN coupler in question.

Note

We recommend assign the PN/PN coupler a device name online. The alternative of calling up the menu item "Target system/write device name on memory card ..." within HW Config can only be used if both coupler ends (X1 and X2) are present in a project or multiproject in STEP 7. When this function is executed, the device names of **both** bus ends X1 and X2 are then written to the SIMATIC Micro Memory Card in a single operation.

Result

Configuration for one end of the PN/PN coupler is complete

Repeat the configuration of the PN/PN coupler and PN/PN coupler slots for the other end and ensure that you add the modules consistently to the other bus end.

Coupling both subnets

Once you have assigned one end of the PN/PN coupler with modules, STEP 7 provides a help function which can be used to automatically assign the other end with suitable modules. However, this requires that the two bus ends X1 and X2 be in the same project or in a multiproject.

Example

In this example, we are assuming that the left end (X1) has already been assigned with modules. To apply the "Coupling" function to the right-hand end (X2), proceed as follows:

1. Double-click the PN/PN coupler X2 symbol. The "Properties - PN/PN coupler" window opens.
2. Switch to the "Coupling" tab and select:
 - In a multiproject select the project for "Project" and the Ethernet subnet of the coupler partner X1 for "Subnet"
 - In a (standard) project, the Ethernet subnet of the coupler partner X1 for "Subnet"
3. Under "Device name", select bus node X1.
4. The "Configuration for:" field is assigned automatically depending on which bus end is configured in the bus node.
5. Confirm your entries by clicking on "OK"

All modules in end X2 of the PN/PN coupler are now added to end X1, and the I/O type and module lengths are specified. You can change the address areas of the modules without the configuration becoming inconsistent. Bus end X2 is now also entered as a bus node in the "Coupling" register of bus node X1.

If you have specified the two ends of a PN/PN coupler as bus nodes using the "Coupling" function and you have a configuration between the two ends which is not consistent, an incorrect configuration will be flagged up when you run the "Save and compile" function in STEP 7.

Tip

We would recommend the following procedure if you make changes to a bus node:

1. Undertaking changes (e.g. adding I/O module)
2. Switch to bus node and in the "Coupling" register, click on "OK"
3. Run the "Save and compile" function for both stations

The configuration is thus always consistent.

4.2.3 Example: Configuration of the inputs/outputs of the PN/PN coupler with STEP 7

Introduction

This example illustrates typical configuration of the PN/PN coupler with STEP 7.

Problem definition

The following assumptions apply to the example:

- **Bus end X1:**

You intend to transfer the following inputs/outputs *to or from the IO Controller*:

2-byte inputs (IN 2 bytes)

8-byte outputs (OUT 8 bytes)

8-byte inputs (IN 8 bytes)

2-byte outputs (OUT 2 bytes)

6-byte inputs/12-byte outputs (IN/OUT 6 bytes/12 bytes)

RD READ

RD WRITE

- **Bus end X2:**

You intend to transfer the following inputs/outputs *to or from the IO Controller*:

2-byte outputs (OUT 2 bytes)

8-byte inputs (IN 8 bytes)

8-byte outputs (OUT 8 bytes)

2-byte inputs (IN 2 bytes)

12-byte inputs/6-byte outputs (IN/OUT 12 bytes/6 bytes)

RD WRITE

RD READ

Configuration of the PN/PN coupler in subnet 1 with STEP 7

Configuration of the PN/PN coupler in subnet 1 (bus end X1) is as follows:

Slot	Module	Order number	I address	Q address	Diagnostic address	Comment
0	PN-PN-Coupler-X1-V20	6ES7 158-3AD01-0XA0			8184*	
X1	PN-PN-Coupler-V20				8183*	
X1	Port 1				8186*	
X1	Port 2				8185*	
1	IN 2 Byte		0...1			
2	OUT 2 Byte			0...7		
3	IN 8 Byte		2...9			
4	OUT 2 Byte			8...9		
5	IN/OUT 6 Byte / 12 Byte		10...15	10...21		
6	RD READ		16...18	22		
7	RD WRITE		19...20			
8						
9						

Figure 4-1 Example: Configuration of the PN/PN coupler in subnet 1

Configuration of the PN/PN coupler in subnet 2 with STEP 7

Configuration of the PN/PN coupler must be exactly the opposite as the configuration in subnet 1. Configuration of the PN/PN coupler in subnet 2 (bus end X2) is then as follows:

Slot	Module	Order number	I address	Q address	Diagnostic address	Comment
0	PN-PN-Coupler-X2-V20-1	6ES7 158-3AD01-0XA0			8184*	
X2	PN-V20-02				8183*	
X2	Port 1				8186*	
X2	Port 2				8185*	
1	OUT 2 Byte			0...1		
2	IN 8 Byte		0...7			
3	OUT 8 Byte			2...9		
4	IN 2 Byte		8...9			
5	IN/OUT 12 Byte / 6 Byte		10...21	10...15		
6	RD WRITE		22...23			
7	RD READ		24...26	16		
8						
9						

Figure 4-2 Example: Configuration of the PN/PN coupler in subnet 2

4.3 Configuration of the PN/PN coupler with another configuring tool

Introduction

You configure the PN/PN coupler using a GSD file. Using this file, the PN/PN coupler is incorporated in your configuring tool as an IO Device. The GSD files can be downloaded on the Internet (<http://support.automation.siemens.com/WW/view/en/23742537>).

GSD file

The following GSD file is available for the PN/PN coupler:

GSDML-V2.2-Siemens-PNNIOC-"Date in format yyyyymmdd".xml

You will find more information about this procedure in the online help for STEP 7.

Configuring the PN/PN coupler

You configure the PN/PN coupler with your configuring tool as you would for any other IO Device with PROFINET IO.

To do this, load the entire GSD file for the PN/PN coupler into your configuring tool. You will have to configure the PN/PN coupler separately in each of the two subnets. To do this, select the device labeled as X1 or X2 (this does not apply to migration GSD).

When assigning device names for the PN/PN coupler, note the following: This device name must be unique on the Ethernet subnet. The device name must satisfy the DNS conventions.

When configuring using a GSD file, you have a choice of input, output, or input/output modules and modules for data record transfer, each of which have a fixed length. Assistance to ensure the correct coupling configuration for the two subnets (as with STEP 7) is not available when configuring a GSD file.

4.4 Parameters

Table 4- 2 Parameters for the PN/PN coupler

	Range of values	Default setting
Voltage check PS1	deactivated / activated	deactivated
Voltage check PS2	deactivated / activated	deactivated
Data validity display DIA	deactivated / activated	deactivated

The parameters for the two ends of the PN/PN coupler can be set separately.

PS1 and PS2 are not assigned to one end and can be monitored separated on both ends.

Interrupts (e.g. when monitoring a power supply) are generated separately for each end.

The data validity display DIA may only be activated if inputs in the affected end of the PN/PN coupler are configured (modules for data record transfer are not included in this).

Voltage check PS1 / PS2

Once voltage check PS1 / PS2 has been released, the PN/PN coupler diagnoses the power supply failure at connection PS1 or PS2.

Only activate the voltage check if the corresponding power supply is actually connected.

Data validity display DIA

The data validity display DIA is used to establish whether the IO Controller connected via the PN/PN coupler from the "other" subnet is still supplying valid data.

The data's validity is always shown in bit 0 of the lowest value input byte of the PN/PN coupler:

Bit 0 = 1: received data are valid, all user data flags are "Good".

Bit 0 = 0: received data are invalid (e.g. because a PN/PN coupler interface is faulty or because the coupler in the "other" subnet has failed or is in STOP mode in the "other" subnet). At least one user data flag is "Bad".

The lowest value input byte comes from the lowest slot number of the first input module.

 WARNING
If "DIA" is activated, you must not use the first bit of the first configured input byte for input data or the associated first bit of the first configured output byte for output data!

4.5 Isochronous real-time communication

Isochronous real-time communication

Synchronized transmission method for the cyclic exchange of IRT data between PROFINET devices. A reserved bandwidth is available within the send cycle for IRT IO data. The reserved bandwidth ensures that IRT data can be transferred at reserved synchronized intervals, without being influenced by other higher network loads (e.g., TCP/IP communication, or additional real-time communication).

The IRT option "high flexibility" provides maximum flexibility during the planning and expansion of the plant. It is not necessary to configure the topology for this option.

The "high performance" IRT option requires a configuration of the topology.

Further information

For further information, refer to the STEP 7 Online Help and the PROFINET System Description (<http://support.automation.siemens.com/WW/view/en/19292127>) Manual.

4.6 Prioritized startup

Prioritized startup

Prioritized startup denotes PROFINET functionality for accelerating the startup of IO Devices in a PROFINET IO system with RT and IRT communication.

The function reduces the time that the correspondingly configured IO Devices require in order to return to the cyclic user data exchange in the following cases:

- After the power supply has returned
- After a station has come back online
- After IO Devices have been activated

Prioritized startup with PN/PN coupler

If you want to use the "Prioritized startup" function for the PN/PN coupler, you must set the function on both ends of the coupler, X1 and X2.

Note

During a prioritized startup, a firmware update using the Micro Memory Card is possible.

Cabling with fixed port setting

If you set a fixed connection setting of the port in STEP 7, you must also disable "Autonegotiation."

Further information

For further information, refer to the STEP 7 Online Help and the PROFINET System Description (<http://support.automation.siemens.com/WW/view/en/19292127>) Manual.

4.7 Device replacement without removable medium/programming device

Device replacement without removable medium/programming device

IO Devices having this function can be replaced simply:

- A removable medium (such as Micro Memory Card) with the stored device name is not required.
- The device name does not have to be assigned using the programming device.

Instead of being assigned a device name from the removable medium or programming device, the IO Device is now assigned a device name by the IO Controller. The IO Controller uses the configured topology for this purpose and the neighborhood relationships derived from the IO Devices. The configured setpoint topology must agree with the actual topology.

It is advisable to reset any I/O Devices that have already been in operation to factory settings before putting them back into operation.

Further information

For further information, refer to the STEP 7 Online Help and the PROFINET System Description (<http://support.automation.siemens.com/WW/view/en/19292127>) Manual.

4.8 SNMP

The PN/PN coupler supports the Ethernet service SNMP. MIB-2 (RFC1213) is supported. R/W objects can be changed using SNMP tools and are saved in the PN/PN coupler. Each of the two bus ends (X1, X2) of the PN/PN coupler has its own memory area for the SNMP data.

Following replacement with a brand new module, the R/W objects in the PN/PN coupler are set to factory settings.

Reset to factory settings

SNMP parameters in non-volatile memory are reset to the delivery condition (*STEP 7*V5.3 SP 3 and higher) in the HW Config dialog "Target system > Ethernet > Edit Ethernet nodes", "Reset" button at "Reset to factory settings".

The following data are **not** deleted when resetting:

- The MAC address
- The I&M0 data

Note

Deleting the device name

The device name is deleted by the "Reset to factory settings" function.

After the device name is deleted, you can then assign a new device name. To do so, open the "General" tab in the Properties dialog for the PN/PN coupler in HW Config. Enter a new device name in the "Device name" entry field.

More information on SNMP can be found in the PROFINET System Description (<http://support.automation.siemens.com/WW/view/en/19292127>) Manual.

4.9 Commissioning the PN/PN coupler

Requirements

Before you can commission the PN/PN coupler, the following requirements must be satisfied:

- You must have fully set up and connected the PN/PN coupler as described in the chapters Assembling (Page 15) and Connecting (Page 19).
- You must have fully set up the two PROFINET IO subnets. PROFINET IO is ready.
- If you are using a SIMATIC Micro Memory Card, it must be inserted into the slot provided in the PN/PN coupler.
- You must have configured the PN/PN coupler (X1 and X2).
- You must have assigned a device name to the PN/PN coupler per subnet.
- You must have undertaken parameterization for the PN/PN coupler.

Commissioning the PN/PN coupler

1. Switch on the power supply for the PN/PN coupler
2. Load the configuration into the target system separately for X1 and X2 using **Target system > Load into module**.

Data record transfer from one IO Controller to another IO Controller

5

Introduction

The data record transfer via the PN/PN coupler, order no. 6ES7158-3AD01-0XA0 and higher, enables acyclic data transfer up to 4096 bytes per slot from one IO Controller (sender) to another IO Controller (receiver). The data record transfer thus allows the previously valid quantity structure (maximum of 256 bytes of I/O data) to be indirectly exceeded.

Principle of operation

The following figure shows the sequence of the transfer of a data record from one IO Controller to another and is followed by an explanation:

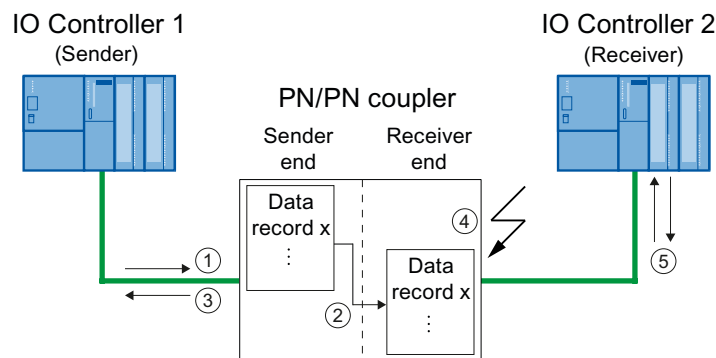

- ① IO Controller 1 (sender) issues a send request to the PN/PN coupler and transfers the data record to the PN/PN coupler.
- ② The PN/PN coupler transfers the data record from its sender end to its receiver end.
- ③ The PN/PN coupler sends an acknowledgement to IO Controller 1 that the data record was received.
- ④ The PN/PN coupler indicates to its receiver end that a data record is available to be read (via status information of the PN/PN coupler and, optionally, via an update interrupt in IO Controller 2 (receiver)).
- ⑤ IO Controller 2 (receiver) reads the status information and the data record and acknowledges the receipt. This deletes the received data record from the buffer of the PN/PN coupler.

Boundary conditions for data record transfer

- Data record transfer does not correspond to data record routing.
- The I/O data (status information) are not coupled as a mirror image.
- The data records are transferred in one direction, from the sender to the receiver.
- Both ends of the PN/PN coupler must exchange data with the connected IO Controllers. If one end is not exchanging data and data for reading are already available, these data are deleted when the end enters into data exchange. The data record transfer starts when both ends are exchanging data with the IO Controllers from a defined status.
- The PN/PN coupler can buffer a maximum of 8 data records per slot, i.e., available for reading. The buffer functions according to the first in - first out (FIFO) principle.
- If the sender attempts to write a data record to the PN/PN coupler even though its buffer is full, the PN/PN coupler rejects the data record.
- If the receiver end does not know the length of the data record, you must request the maximum possible length of 4096 bytes in the read request to ensure that the entire data record is read.

Configuration for the data transfer

To use this function, you must configure a virtual module on both ends of the PN/PN coupler (X1 and X2), "RD WRITE" on sender end and "RD READ" on receiver end:

The representation of the two modules in the HW Config catalog is shown below:

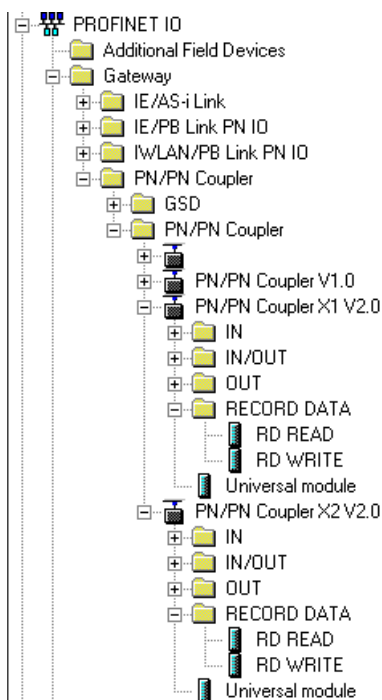

Maximum number of sender and receiver modules

You can configure a maximum of 16 "RD WRITE" and "RD READ" modules per PN/PN coupler (max. Data record length of 4096 bytes).

Structure and meaning of status information for data record transfer in PN/PN coupler

Table 5- 1 Status information for data record transfer

Assigned I/O areas	Name	Function
Sender module RD WRITE		
EB x	provider_status	Bit 0 = 1 Communication with other bus end is established and module "RD READ" has been configured on the other bus end. Bit 1 = 1 Query the "level_counter": Maximum value of 8 data records was not reached Bit 7 = 1 Enable the data record transfer in the PN/PN coupler (= group enable; comprises the information from Bit 0 and Bit 1)
EB x+1	level_counter	Indicates the fill level of the buffer (maximum of 8 data records)
Receiver module RD READ		
EW x	record_index	Indicates the data record number of the data record that can be read on the receiver end
EB x+2	cycle_counter	Each change in the value (incremental) means that a new data record can be read on the receiver side
AB x	ack_counter	cycle_counter = ack_counter means that the receiver has acknowledged reading the data record; the data record is then deleted from the buffer

Update interrupt (OB 56)

Optionally, you can enable an update interrupt during parameterization of the "RD READ" module that indicates to the receiver that a new data record is available for reading in the buffer of the PN/PN coupler. The update interrupt is disabled by default. A new update interrupt can only be issued when the preceding interrupt has been acknowledged in the user program.

Example program for data record transfer

Below is a program example for data record transfer from a sender (CPU 317-2 PN/DP) to a receiver (CPU 319-3 PN/DP). The data are provided on the sender end for transfer in DB 12 and stored on the receiver end in DB 13.

Sender end: CPU 317-2 PN/DP and PN/PN coupler, bus end X1

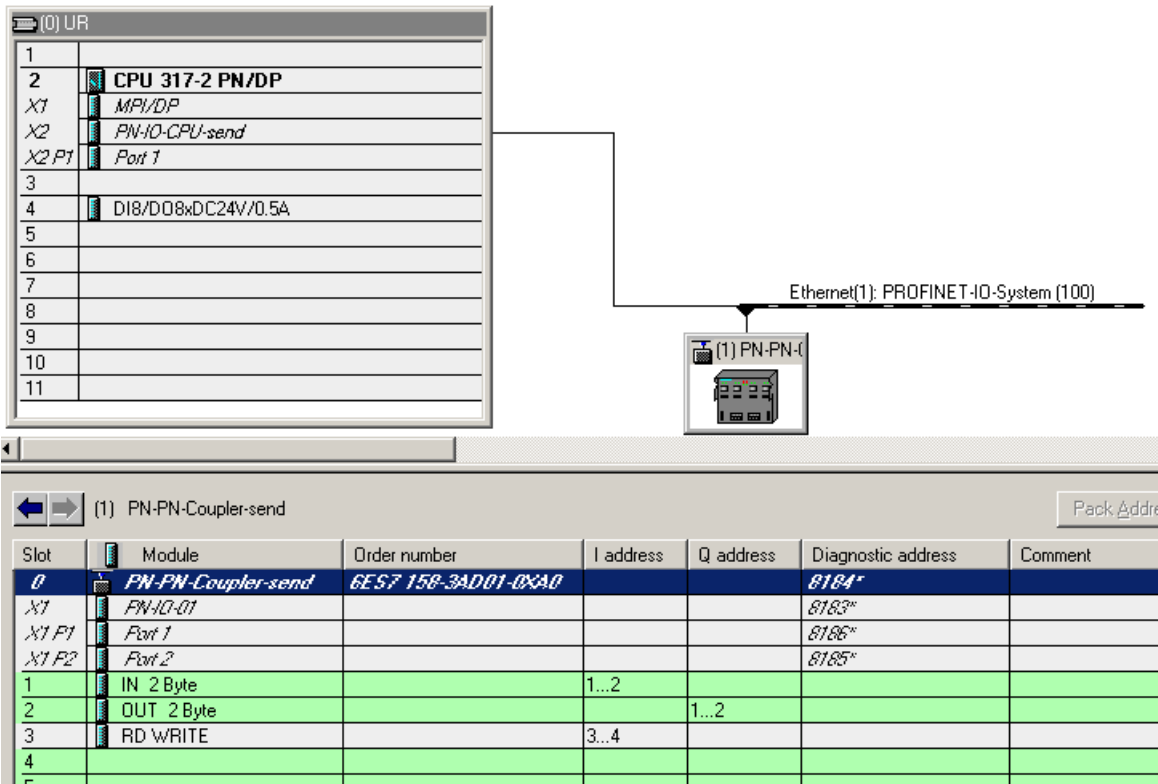

Figure 5-1 Configuration example PN/PN coupler, bus end X1

Table 5-2 Function: Writing a data record with SFB 53 "WRREC"

SFB 53 "WRREC"			
L	IB	4	//level counter
L		8	//Maximum value level_counter
<I			
A	I	3.7	//provider_status.enable
AN	M	10.2	//busy_bit
=	M	10.0	//req_bit
CALL	"WRREC",	DB53	//sfb53
REQ	:=M10.0		
ID	:=DW#16#3		//Address RD WRITE module
INDEX	:=DB12.DBW0		//provision of index
LEN	:=DB12.DBW2		//provision of length
DONE	:=M10.1		
BUSY	:=M10.2		
ERROR	:=M10.3		
STATUS	:=MD12		
RECORD	:=P#DB12.DBX4.0	BYTE 4096	//reserved for maximum length

Receiver end: CPU 319-3 PN/DP and PN/PN coupler, bus end X2

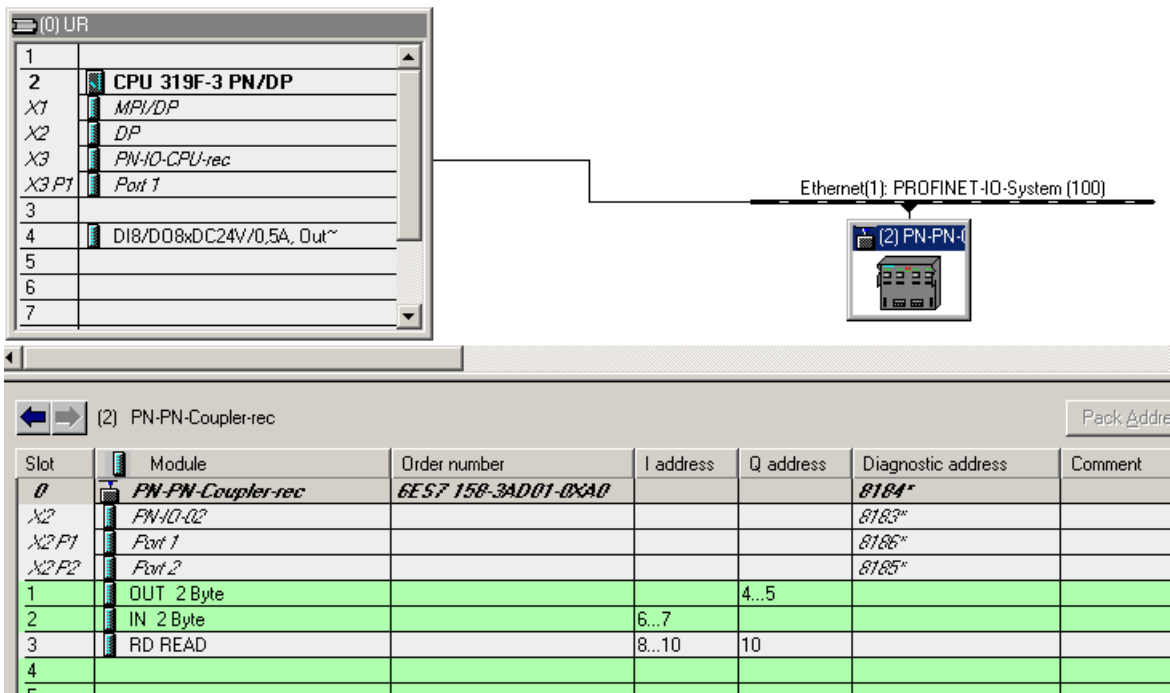

Figure 5-2 Configuration example PN/PN coupler, bus end X2

Table 5-3 Function: Reading a data record with SFB 52 "RDREC"

SFB 52 "RDREC"				
L	IB	10		//cycle_counter
L	MB	8		//old value cycle_counter
==I				
JC	MA01			//cycle_counter not incremented
L	IW	8		//record_index
OPN	DB	13		//save record_index
T	DBW	0		
AN	M	0.2		//busy_bit
=	M	0.0		//req_bit
CALL	"RDREC", DB52			
REQ	:=M0.0			
ID	:=DW#16#8			
INDEX	:=DB13.DBW0			
MLEN	:=4096			
VALID	:=M0.1			
BUSY	:=M0.2			
ERROR	:=M0.3			
STATUS	:=MD2			
LEN	:=DB13.DBW2			
RECORD	:=P#DB13.DBX4.0 BYTE 4096			//destination buffer
AN	M	0.1		//valid bit
JC	MA01			
L	IB	10		//cycle_counter
T	MB	8		//save cycle_counter
T	AB	10		//ack_counter
MA01:	BE			

Operating

6.1 Response times of the PN/PN coupler

Overview

This section covers the average time it takes to transfer data from the IO Controller (subnet 1) via the PN/PN coupler to the IO Controller (subnet 2).

Response times

The time between an IO Controller writing data in the outputs' process image and the time when this data can be read in the process image of the second IO Controller depends on the following parameters:

- CPU cycle time of the two IO Controllers
- Bus cycle time of the associated IO Controller
- Copy time within the PN/PN coupler (T_{COPY})
- Total data length in bytes (input/output)

The copy time within the PN/PN coupler is not dependent on the data transfer rate used. It consists of the copy routine for the inputs and for the outputs. The following maximum values apply:

- Outputs: $T_{\text{COPY}} = 108 \mu\text{s} + n \times 0.4 \mu\text{s}$
- Inputs: $T_{\text{COPY}} = 220 \mu\text{s} + n \times 0.8 \mu\text{s}$

The two times should be added together. Even with the maximum size of the data which can be transferred (256-byte input data and 256-byte output data), the copy time is < 1 ms.

Influencing factors for the response times

The following applies to time-critical applications:

- Exchange as little data as possible via the PN/PN coupler.
- Do not request diagnostic data from the IO Controller.
- Do not activate the data validity display DIA.

6.2 SIMATIC Micro Memory Card

Insertion of the SIMATIC Micro Memory Card

A SIMATIC Micro Memory Card is used as the memory medium for the PN/PN coupler.

The following data is saved on the SIMATIC Micro Memory Card.

- Technology data (device names)
- Data for a firmware update

Note

On **one** SIMATIC Micro Memory Card, you can save **either** technology data **or** update data.

Service life of a SIMATIC Micro Memory Card

The life of an SIMATIC Micro Memory Card essentially depends on the following factors:

- Number of deletion or programming operations
- External factors, such as ambient temperature

At an ambient temperature up to 60 ° C a SIMATIC Micro Memory Card has a useful life of 10 years at maximum 100,000 write/delete sequences.



CAUTION

Possible data loss

If the maximum number of write/delete operations is exceeded, data loss is possible.

Applicable SIMATIC Micro Memory Cards

The following memory modules are available for use:

A SIMATIC Micro Memory Card 64k is sufficient for storing the name of the device. The SIMATIC Micro Memory Cards with at least 2 MB of storage capacity are required when conducting a firmware update.

The order numbers for the memory modules can be found in Appendix Order numbers and accessories (Page 79).

Inserting/replacing the card

The SIMATIC Micro Memory Card is designed so that it can also be removed and inserted while current is flowing.

Note

The SIMATIC Micro Memory Card is recognized only during the startup of the PN/PN coupler. Insertion of the card during operation will be ignored.

The beveled corner of the SIMATIC Micro Memory Card prevents it from being inserted backwards (reverse polarity protection).

The receptacle is located on the top of the PN/PN coupler.

If necessary, remove the PN/PN coupler to access the receptacle. To remove the SIMATIC Micro Memory Card, gently press it downwards. The SIMATIC Micro Memory Card is thereby unlocked and is released from the receptacle.

6.3 Updating firmware

You can update the PN/PN coupler's firmware:

- Via PROFINET IO, e.g. using HW configuration or in the SIMATIC Manager using **Target system > Display accessible nodes**
- Using the SIMATIC Micro Memory Card

To update the firmware, you will need files (*.UPD) containing the current firmware.

The firmware can be updated via both PROFINET IO interfaces.

The following requirements must be satisfied:

- The PN/PN coupler whose firmware you want to update must be accessible online.
- The files with the current firmware version must be available in the file system of your programming device or PC.

The STEP 7 online help system provides information on how to proceed.

6.3.1 Updating firmware using SIMATIC Micro Memory Card

Requirements

To update the firmware of a PN/PN coupler, you will need:

- STEP 7 Version 5.3 or higher, Service Pack 1
- A SIMATIC Micro Memory Card with at least 2 MB of memory
- A PC or PG with equipment for describing a SIMATIC Micro Memory Card

Procedure

You update the firmware in two stages:

1. Transfer the update files to a SIMATIC Micro Memory Card.
2. Undertake the firmware update for a PN/PN coupler.

Transfer the update files to a SIMATIC Micro Memory Card

1. Use Windows Explorer to produce a new directory.
2. Download the required update file from the Internet into this directory.
3. Unpack this update file into this directory. This directory contains three files with the extension UPD.
4. Insert a SIMATIC Micro Memory Card (≥ 2 MB) into the programming device or writing device.
5. In the SIMATIC Manager, select the menu command **Target system > Update operating system**.
6. If necessary, confirm deletion of the SIMATIC Micro Memory Card.
7. In the dialog field displayed, select the directory containing the UPD files.
8. Double-click one of the UPD files. The data are written to the SIMATIC Micro Memory Card.

The update files are now contained on the SIMATIC Micro Memory Card.

Undertake the firmware update

1. De-energize the PN/PN coupler and plug the SIMATIC Micro Memory Card containing the firmware update into the receptacle.
2. Switch on the power supply for the PN/PN coupler.

The PN/PN coupler automatically detects the SIMATIC Micro Memory Card containing the firmware update and starts to update the module. During the firmware update, the SF and BF LEDs on end X1 light up while the ON LED is off.

Once the update is complete, the BF-LED on end X1 flashes with 0.5 Hz.

3. De-energize the PN/PN coupler and remove the SIMATIC Micro Memory Card containing the firmware update.
4. Plug in the SIMATIC Micro Memory Card containing the device name and switch the power supply back on.

The PN/PN coupler boots up with the new firmware and is then ready.

6.4 Replacing defective PN/PN coupler

Replacement part case

Before you can use a previously used PN/PN coupler as a replacement part, it must be "reset to factory settings".

Procedure

The following list shows the steps required for replacing a defective PN/PN coupler.

1. Remove the bus connector from the PROFINET IO interfaces of the defective PN/PN coupler.
2. Remove the power supply unit from the defective PN/PN coupler.
3. If applicable, remove the SIMATIC Micro Memory Card containing the device name from the defective PN/PN coupler.
4. Replace the defective PN/PN coupler.
5. If applicable, plug in the SIMATIC Micro Memory Card containing the device name in the new PN/PN coupler.
6. Plug the power supply connection into the new PN/PN coupler.
7. Plug the bus connector into the PROFINET IO interfaces of the new PN/PN coupler.

Device replacement without removable medium/programming device

You can replace the PN/PN coupler, order number 6ES7158-3AD01-0XA0 or higher, without a removable medium/programming device. The replacement PN/PN coupler receives the device name of the IO Controller (see Chapter Device replacement without removable medium/programming device (Page 36)).

6.5 Identification data

Definition

Identification data are information saved in a module which assist the user when:

- checking the plant configuration
- locating hardware changes on a plant
- remedying faults in a plant

Identification data enable modules to be uniquely identified online.

In STEP 7, the identification data are displayed in the registers "Module status - PN/PN coupler" and "Properties- PN/PN coupler" (see online help for STEP 7).

Reading identification data

Each of the two bus ends (X1, X2) of the PN/PN coupler has its own memory area for the identification data. You can enter or read out the identification data for each of the two bus ends separately (does not pertain to I&M0).

You can access specific identification data using **Read data record**. You will find the appropriate piece of identification data under the associated data record index.

The data records are structured using the following principle:

Table 6- 1 Basic structure of data records which contain ID data.

Content	Length (bytes)	Coding (hex)
Header information		
BlockType	2	I&M0: 0020 I&M1: 0021 I&M2: 0022 I&M3: 0023
BlockLength	2	I&M0: 0038 I&M1: 0038 I&M2: 0012 I&M3: 0038
BlockVersionHigh	1	01
BlockVersionLow	1	00
Identification data		
Identification data (see following table)	I&M0: 54 I&M1: 54 I&M2: 16 I&M3: 54	

The data structures in the data records correspond to the PROFINET IO definitions.

Table 6- 2 Identification data

Identification data	Access	Default setting	Explanation
Identification data 0: (Data record index AFF0 hex)			
VendorIDHigh	Read (1 byte)	00 hex	The name of the manufacturer is stored here. (42 dec = SIEMENS AG)
VendorIDLow	Read (1 byte)	2A hex	
Order_ID	Read (20 byte)	6ES7158-3AD01-0XA0	Order number of the module
IM_SERIAL_NUMBER	Read (16 byte)		Serial number (device-specific)
IM_HARDWARE_REVISION	Read (2 bytes)	1	Depending on HW version
IM_SOFTWARE_REVISION	Read	Firmware version	This indicates the firmware version of the module.
• SWRevisionPrefix	(1 byte)	V, R, P, U, T	
• IM_SWRevision_Functional_Enhancement	(1 byte)	01 - FF hex	
• IM_SWRevision_Bug_Fix	(1 byte)	00 - FF hex	
• IM_SWRevision_Internal_Change	(1 byte)	00 - FF hex	
IM_REVISION_COUNTER	Read (2 bytes)	-	This indicates the parameterized changes on the module.
IM_PROFILE_ID	Read (2 bytes)	0000	Generic Device
IM_PROFILE_SPECIFIC_TYPE	Read (2 bytes)	0005 hex	on interface modules
IM_VERSION	Read	0101 hex	This indicates the version of the identification data (0101 hex = Version 1.1)
• IM_Version_Major	(1 byte)		
• IM_Version_Minor	(1 byte)		
IM_SUPPORTED	Read (2 bytes)	000E hex	This indicates the identification data available (I&M1 to I&M3)
Maintenance data 1: (Data record index AFF1 hex)			
IM_TAG_FUNCTION	Read/write (32 bytes)	-	Enter identification for the module here which is unique throughout the plant.
IM_TAG_LOCATION	Read/write (22 bytes)	-	Enter the installation location of the module here.
Maintenance data 2: (Data record index AFF2 hex)			
IM_DATE	Read/write (16 bytes)	YYYY-MM-DD HH:MM	Enter the installation date of the module here.
Maintenance data 3: (Data record index AFF3 hex)			
IM_DESCRIPTOR	Read/write (54 bytes)	-	Enter a comment on the module here.

Diagnostics

7.1 Diagnostics via LED displays

LEDs on the PN/PN coupler

Descriptions of the LEDs on the PN/PN coupler and their function can be found below.

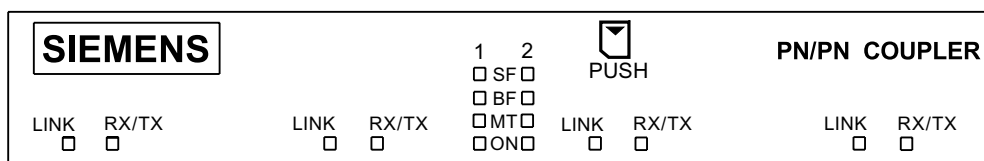

SF 1	Group fault for PROFINET IO subnet 1 (red)
SF 2	Group fault for PROFINET IO subnet 2 (red)
BF 1	Bus fault for PROFINET IO subnet 1 (red)
BF 2	Bus fault for PROFINET IO subnet 2 (red)
MT 1	Maintenance display for PROFINET IO subnet 1 (yellow)
MT 2	Maintenance display for PROFINET IO subnet 2 (yellow)
ON	Power supply 24 V DC (green)
LINK	Connection to a switch or IO Controller (green), per interface
RX/TX	Data exchange (yellow), per interface

Status and fault displays by LEDs on the PN/PN coupler

Table 7- 1 Status and fault displays on the PN/PN coupler

LEDs				Meaning	Remedy
SF	BF	MT	ON		
off	off	off	off	The PN/PN coupler is not energized or there is a hardware defect on the PN/PN coupler.	Switch on the DC 24 V power supply for the PN/PN coupler.
*	*	*	on	The PN/PN coupler is energized.	—
*	Flashing 0.5 Hz	*	on	Incorrect or no connect telegram - there is no exchange of data between the IO Controller and interface module (IO Device), the IO Device is however physically linked to the switch. Causes: <ul style="list-style-type: none"> • Incorrect device name • Error in configuration • Parameterization error • The IO Controller is switched off, defective or there is no bus cable to the IO Controller. 	<ul style="list-style-type: none"> • Check the configuration and parameterization. • Check the device names. • Assign a valid device name to the PN/PN coupler. • Check the IO Controller.
*	on	*	on	There is no link signal on either of the two ports at the corresponding bus end.	<ul style="list-style-type: none"> • Establish a connection to the IO Controller (via a switch). • Assign a valid device name to the PN/PN coupler. • Check the bus configuration. • Check that the bus connector is correctly inserted. • Check whether the bus cable to the I/O controller is interrupted.
on	*	*	on	<ul style="list-style-type: none"> • Configured setup of two ends of PN/PN coupler does not match actual setup. • Voltage monitoring PS1+PS2 was configured but only one power supply is connected or one power supply has failed • GSD configuration without input modules, but DIA bit was set. 	<ul style="list-style-type: none"> • Check that configuration is identical at the two ends (e.g. using STEP 7) and remedy the parameterization fault. • Ensure that there are two power supplies. • Configure input modules.
on	on	*	on	A brand new SIMATIC Micro Memory Card is being formatted.	Wait until the formatting sequence is complete. This may take several minutes. The formatting sequence is completed when the SF LED goes out.
off	off	*	on	Data exchange is taking place between the IO Controller and PN/PN coupler. Planned and actual configuration of PN/PN coupler match.	—

LEDs				Meaning	Remedy
SF	BF	MT	ON		
on	on	*	off	FW update via SIMATIC Micro Memory Card is running; display only during FW update via SIMATIC Micro Memory Card and display only for subnet 1 (left LED side), right LED side remains off	—
off	Flashing 0.5 Hz	*	off	FW update successful (with Micro Memory Card)	—
on	Flashing 0.5 Hz	*	off	External fault during FW update (e.g. incorrect FW)	Use the correct FW for the update.
on	Flashing 2 Hz	*	off	Internal fault during FW update (e.g. write/read fault)	Repeat the FW update.
*	*	on	on	<ul style="list-style-type: none"> Loss of synchronization Network error 	See also maintenance alarms in Chapter Interrupts (Page 58).
*) not relevant					

LEDs		Meaning	Remedy
LINK	RX/TX		
off	off	No connection to switch/IO Controller.	Check whether a uniform baud rate is set for all devices on a stream. Check that the bus cable is plugged in.
on	*	Connection to switch/IO Controller.	—
on	on	Transmission/reception is in progress	—

7.1 Diagnostics via LED displays

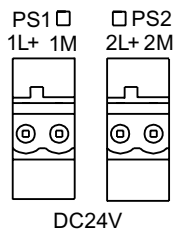

LEDs		Meaning	Remedy
PS1	PS2		
on	on	The PN/PN coupler has two power supplies (to PS1 and PS2).	—
on	off	The PN/PN coupler has one power supply (to PS1).	—
		With redundant power supply: Power supply to PS2 has failed.	Also power the PN/PN coupler with voltage PS2
off	on	The PN/PN coupler has one power supply (to PS2).	—
		With redundant power supply: Power supply to PS1 has failed.	Also power the PN/PN coupler with voltage PS1.
off	off	The PN/PN coupler is not being powered.	Power the PN/PN coupler with voltage to PS1 or to PS1 and PS2.

7.2 Diagnostics by user program

7.2.1 Manufacturer-specific diagnostics

The PN/PN coupler produces manufacturer-specific diagnostics for the following events:

- Failure of power supplies PS 1 and PS 2
- Other network end is not configured or has failed
- Configuration of subnets X1 and X2 differs
- Parameter DIA (data validity) set but no inputs configured

Manufacturer-specific diagnostics are 4 bytes each.

The following table lists the assignments available.

Byte	0	1	2	3
Content	1	1 – failure of power supply on left 2 – failure of power supply on right	0	0
	2	1 – Other network parts are not configured or failed 2 – Configuration of subnets X1 and X2 differs 4 – Parameter DIA (data validity display) set but no input data configured	0	0

For I/O modules, the following applies: If the IO Controller fails or the bus cable is removed, the PN/PN coupler supplies input values to the other bus end featuring substitute value "0" and sets the user data flag to "Bad".

If the two bus ends of the PN/PN coupler do not have matching configuration, in the dialog "Module status" of the last configured bus end, STEP 7 also supplies information on the slots with differing configuration.

For virtual modules "RD WRITE" and "RD READ", the following applies: If the IO Controller fails or the bus cable is removed, status information will continue to be provided for the data record transfer. The user data flag remains at "Good". If there is no slot-based mirror-image configuration of the two coupler ends, the user data flag of the subsequently configured end returns "Bad".

7.2.2 Interrupts

The I/O device generates interrupts as a reaction to specific error events. Interrupts are evaluated based on the I/O controller used.

The PN/PN coupler supports the following interrupts:

- Diagnostic interrupts

If there is communication between the IO Controller and PN/PN coupler, manufacturer-specific diagnostics of the PN/PN coupler are also active as interrupts which result in an OB 82 being called up in a SIMATIC CPU.

- ReturnOfSubmodule interrupts

User data flags provide information about the validity of the IO data of a slot. If a user data flag changes from "Bad" to "Good", a ReturnOfSubmodule interrupt is produced which results in a OB 83 being called up within a SIMATIC-CPU.

The bus end of the PN/PN coupler which has already been configured produces a ReturnOfSubmodule interrupt during configuration of the other bus end for each of the matching slot in the configuration.

- For virtual module "RD READ": Update interrupt (OB 56)

Optionally, you can enable an update interrupt during parameterization of the "RD READ" module that indicates to the receiver that a new data record is available for reading in the buffer of the PN/PN coupler. The update interrupt is disabled by default. A new update interrupt can only be issued when the preceding interrupt has been acknowledged in the user program.

- Maintenance alarms

The PN/PN coupler supports the diagnostics and maintenance concept in PROFINET in accordance with IEC 61158-6-10. The goal is early detection and correction of potential faults.

For the PN/PN coupler, maintenance alarms signal to the the user when network components must be checked or replaced.

Maintenance alarms

The PN/PN coupler signals a maintenance alarm to the higher-level diagnostics unit when the following events occur:

Maintenance alarms	Event	Message/Meaning
Level 1: Maintenance required	Network error	<ul style="list-style-type: none"> • Message frames rejected ¹ <p>The integrated switch has rejected 3 message frames due to network overload.</p>
Level 2: Maintenance demanded LED MT is lit	Loss of synchronization	<ul style="list-style-type: none"> • No synchronization message frame received <p>After parameterization or during operation, the sync master did not receive a synchronization message frame within the timeout period.</p> <ul style="list-style-type: none"> • Jitter lies outside the limits <ul style="list-style-type: none"> – The maximum permissible jitter has been exceeded during synchronization. – A sync slave has been synchronized by the sync master again.
	Network error	<ul style="list-style-type: none"> • Message frames rejected ¹ • The integrated switch has rejected 10 message frames due to network overload.
¹ These diagnostic messages are deleted automatically after 1 second.		

System alarms in *STEP 7*

The maintenance information is generated in *STEP 7* using the following system alarms:

- Maintenance required, identified by a green wrench icon at the relevant port.
- Maintenance demanded, identified by a yellow wrench icon at the relevant port.

7.2.3 Diagnostics readout

Options for reading out the diagnostic data

Manufacturer-specific diagnostic data can be evaluated using the corresponding data records (e.g 0x800B) or using diagnostics interrupts.

Table 7- 2 Reading out the diagnostic data with STEP 7.

Automation system with IO Controller	Module or register in STEP 7	Application	See ...
SIMATIC S7	in HW configuration using Station > Open online	Device diagnostics in form of plain text on STEP 7 interface (in the Quick View, Diagnostics View, or Module Status windows)	Diagnosing hardware in <i>STEP 7 online help</i>
	SFB 52 "RDREC"	Read data records from the I/O device	SFB see <i>STEP 7 online help</i> (system functions/system function blocks)
	SFB 54 "RALRM"	Receiving interrupts from the IO Device	SFB see <i>STEP 7 online help</i> (system functions/system function blocks)

Structure of diagnostic data records

You will find the structure of the diagnostic data records and examples for programming in the From PROFIBUS DP to PROFINET IO (<http://support.automation.siemens.com/WW/view/en/19289930>) Programming Manual, in the chapters "Structure of diagnostic data records" and "Examples of diagnostic data records".

The data records which the PN/PN coupler supports are based on standard PROFINET IO - Application Layer Service Definition V2.0.

You can download the standard from the Internet (<http://www.profibus.com>) free of charge.

Structure of the manufacturer-specific diagnostics data records

The structure of the diagnostics data records is differentiated based on the BlockVersion. The following BlockVersions apply to the PN/PN coupler:

PN/PN coupler	BlockVersion
6ES7158-3AD01-0XA0 and higher	W#16#0101

Manufacturer-specific diagnostics in the User Structure Identifier (USI)

For the PN/PN coupler, the following manufacturer-specific diagnostics are signaled in the USI.

- Failure of a power supply: USI = W#16#0001
- Configuration error: USI = W#16#0002

Structure USI = W#16#0001

Table 7- 3 Structure USI = W#16#0001

Data block name	Content	Comment	Bytes
USI	W#16#0001	Manufacturer-specific diagnostics for failure of a power supply	2
The number of the failed power supply supplies.			
	Number of the power supply	B#16#01 or B#16#02	1
2 reserved bytes follow.			
	Reserved		1
	Reserved		1

Structure USI = W#16#0002

Table 7- 4 Structure of USI = W#16#0002

Data block name	Content	Comment	Bytes
USI	W#16#0002	Manufacturer-specific diagnostics for a configuration error	2
Corroboration of the configuration follows.			
	Other network end is not configured or has failed.	B#16#01	1
	Deviating configuration of the subnets.	B#16#02	1
	Parameter DIA set but no input data configured.	B#16#04	1
2 reserved bytes follow.			
	Reserved		1
	Reserved		1

7.2.4 Example of diagnostics

Introduction

This example illustrates how to call up typical diagnostics for the PN/PN coupler.

Problem definition

The following assumptions apply to the example:

- Power supply PS2 (right) has failed.
- The PN/PN coupler has diagnostics address 8180 (corresponding to 1FF4_H).
- The following picture shows an example of the structure of a diagnostic evaluation.

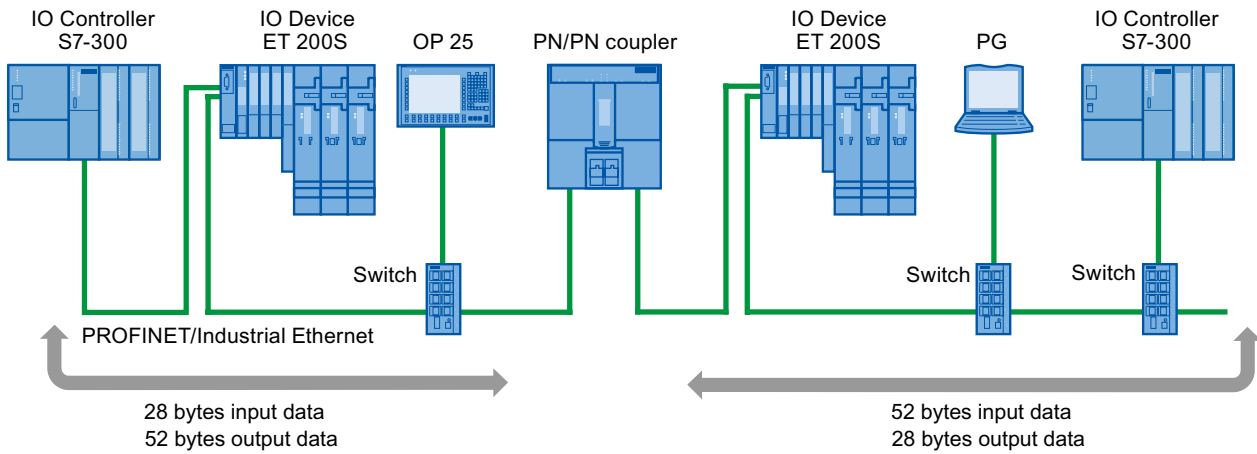

Figure 7-1 Example of structure for a diagnostic evaluation of the PN/PN coupler

There are two ways of reading out the diagnostic interrupt:

- using SFB 52 ("RDREC")
- using SFB 54 ("RALRM")

Solution using SFB 52 ("RDREC")

In OB 1, call up SFB 52 and read out a diagnostic data record (e.g. C00C or E00C).

Table 7- 5 STL code for reading out diagnostics

```

STL
AN  M10.3      // Once the reading process is complete (BUSY flag = 0)...
AN  M10.1      // ...and there is no request trigger for reading the data record (REQ = 0)...
S   M10.1      // ...then the transfer of data records begins (REQ = 1)
L   W#16#C00C  // Use diagnostic data record W#16#C00C
M   MW6        // Load W#16#C00C into memory word 6

CALL SFB 52, DB56
REQ      :=M10.1      // Request to read the diagnostic data
ID       :=W#16#1FF4  // Diagnostics address
INDEX    :=MW6        // Data record number
MLEN     :=200        // Maximum length of the data to be read
VALID    :=M10.2      // Validity of data record
BUSY     :=M10.3      // Indication of whether reading request is still active
                        (BUSY=1)
ERROR    :=M10.4      // Error flag
STATUS   :=MD12       // Error code
LEN      :=MW16       // Length of the read data
RECORD   :=P#DB52.DBX0.0 // Destination area for the read data record
                        BYTE 512

U   M10.1
R   M10.1      // Reset request flag

```

Create the following structure for DB 52:

Address	Name	Type	Initial value	Comment
0.0		STRUCT		
+0.0	ds	ARRAY[1..512]		Diagnostics data
*1.0		BYTE		
=512		END_STRUCT		

Content of DB 52 after triggering diagnostics:

Address	Content	Meaning
DB52.DBB0	00 _H	BlockType W#16#0010: Data record of diagnostic data record type
DB52.DBB1	10 _H	
DB52.DBB2	00 _H	BlockLength W#16#0013: 19 more bytes follow
DB52.DBB3	13 _H	
DB52.DBB4	01 _H	BlockVersion High and low byte
DB52.DBB5	01 _H	
DB52.DBB6	00 _H	API
DB52.DBB7	00 _H	
DB52.DBB8	00 _H	
DB52.DBB9	00 _H	
DB52.DBB10	00 _H	SlotNumber W#16#0000: Slot number of interrupt-triggering component
DB52.DBB11	00 _H	
DB52.DBB12	00 _H	SubslotNumber W#16#0001: Sub-module slot number
DB52.DBB13	01 _H	
DB52.DBB14	00 _H	ChannelNumber W#16#0000: Identification of interrupt source: manufacturer-specific
DB52.DBB15	00 _H	
DB52.DBB16	08 _H	ChannelProperties W#16#0800 = 0000 1000 0000 0000: Bit 11 - 12 = 01: pending diagnostics
DB52.DBB17	00 _H	
DB52.DBB18	00 _H	UserStructureIdentifier (USI) W#16#0001: manufacturer-specific: Failure of one power supply
DB52.DBB19	01 _H	
DB52.DBB20	02 _H	Data B#16#02: Failure of power supply on right
DB52.DBB21	00 _H	
DB52.DBB22	00 _H	

Solution using SFB 54 ("RALRM")

In OB 82, call up SFB 54 and read out the diagnostic interrupt data.

Table 7- 6 STL code for reading out diagnostic interrupts

CALL SFB 54, DB54		
MODE	:=1	// Operating mode
F_ID	:=DW#16#1FF4	// Log. start address of module from where interrupt is to be received
MLEN	:=200	// Maximum length of the interrupt information to be read
NEW	:=	// A new interrupt has been received (NEW = 1)
STATUS	:=	// Error code
ID	:=	// Log. start address of component from where interrupt has been received
LEN	:=	// Length of the read interrupt information
TINFO	:=P#DB80.DBX0.0 BYTE 32	// Destination area for OB start information and administrative information
AINFO	:=P#DB81.DBX0.0 BYTE 255	// Destination area for header information and additional interrupt information

Create the following structure for DB 80:

Address	Name	Type	Initial value	Comment
0.0		STRUCT		
+0.0	T_INFO	ARRAY[1..32]		T_INFO
*1.0		BYTE		
=256		END_STRUCT		

Create the following structure for DB 81:

Address	Name	Type	Initial value	Comment
0.0		STRUCT		
+0.0	A_INFO	ARRAY[1..255]		A_INFO
*1.0		BYTE		
=256		END_STRUCT		

Content of DB 80 after triggering diagnostics:

Address	Content	Meaning
DB80.DBB0	39 _H	<p style="text-align: center;">Start information OB 82 (Bytes 0-19) (For structure, see online help OB 82)</p>
DB80.DBB1	42 _H	
DB80.DBB2	19 _H	
DB80.DBB3	52 _H	
DB80.DBB4	C5 _H	
DB80.DBB5	54 _H	
DB80.DBB6	1F _H	
DB80.DBB7	F4 _H	
DB80.DBB8	0D _H	
DB80.DBB9	33 _H	
DB80.DBB10	00 _H	
DB80.DBB11	00 _H	
DB80.DBB12	06 _H	
DB80.DBB13	08 _H	
DB80.DBB14	18 _H	
DB80.DBB15	09 _H	
DB80.DBB16	30 _H	
DB80.DBB17	55 _H	
DB80.DBB18	09 _H	
DB80.DBB19	96 _H	
DB80.DBB20	80 _H	Address of interrupt source
DB80.DBB21	01 _H	
DB80.DBB22	08 _H	Device type
DB80.DBB23	00 _H	Interrupt info
DB80.DBB24	00 _H	Flags of PROFINET IO Controller connection
DB80.DBB25	01 _H	
DB80.DBB26	06 _H	Administrative information
DB80.DBB27	04 _H	
DB80.DBB28	00 _H	
DB80.DBB29	2A _H	
DB80.DBB30	00 _H	
DB80.DBB31	01 _H	

Content of DB 81 after triggering diagnostics:

Address	Content	Meaning
DB81.DBB0	00 _H	BlockType W#16#0002: Interrupt information
DB81.DBB1	02 _H	
DB81.DBB2	00 _H	BlockLength W#16#001B: 27 more bytes follow
DB81.DBB3	1B _H	
DB81.DBB4	01 _H	BlockVersion High and low byte
DB81.DBB5	00 _H	
DB81.DBB6	00 _H	AlarmType W#16#0001: Diagnostic interrupt (incoming)
DB81.DBB7	01 _H	
DB81.DBB8	00 _H	API
DB81.DBB9	00 _H	
DB81.DBB10	00 _H	
DB81.DBB11	00 _H	
DB81.DBB12	00 _H	SlotNumber W#16#0000: Slot number of interrupt-triggering component
DB81.DBB13	00 _H	
DB81.DBB14	00 _H	SubslotNumber W#16#0001: Sub-module slot number
DB81.DBB15	01 _H	
DB81.DBB16	00 _H	ModulldentNumber
DB81.DBB17	00 _H	
DB81.DBB18	00 _H	
DB81.DBB19	01 _H	
DB81.DBB20	00 _H	SubmodulldentNumber
DB81.DBB21	00 _H	
DB81.DBB22	00 _H	
DB81.DBB23	01 _H	
DB81.DBB24	B0 _H	AlarmSpecifier W#16#B002: Bit 12 = 1: manufacturer-specific diagnostics
DB81.DBB25	02 _H	
DB81.DBB26	00 _H	UserStructureIdentifier (USI) W#16#0001: manufacturer-specific: Failure of one power supply
DB81.DBB27	01 _H	
DB81.DBB28	02 _H	Data B#16#02: Failure of power supply on right
DB81.DBB29	00 _H	
DB81.DBB30	00 _H	

7.2.5 Data validity display

Information covering all stations on the validity of the input data supplied by the other bus end of the PN/PN coupler can be interrogated directly in the user program using the DIA parameter (data validity display).

See also

Parameters (Page 34)

7.2.6 Evaluation of the useful data flag

Each IO module is assigned a value in the input or output data message; this value provides a statement on the quality of this user datum. For example, outputs of a specific module can be switched off by means of this without affecting other modules.

If inputs or outputs whose useful data flag is "Bad" are accessed, the corresponding CPU calls up fault OB 85 or 122 (depending on whether the datum in question is in the process image or the extended process image of the CPU).

7.2.7 STOP of the IO controller and recovery of the IO device

IO controller stop

When in STOP mode, the IO controller supplies output data with a "Bad" useful data flag.

The PN/PN coupler indicates to the other bus end that the IO controller is in STOP mode by not producing any of its own diagnostics.

Diagnostics events triggered by a STOP of the IO controller

Diagnostics frames received from the IO device while the IO controller is in STOP mode will not result in any the corresponding OBs being start once the IO controller starts up. You have to produce yourself a image in OB 100 of the status of the IO device.

Diagnostics after recovery of the IO device

During recovery of an IO device, you must use SFB 52 to read data record E00C_H. This contains all the diagnostics data for the slots assigned to an IO controller in an IO device.

Technical data

A.1 Technical data for PN/PN coupler (6ES7158-3AD01-0XA0)

Overview

Dimensions and weight	
Dimensions W x H x D (mm)	120 × 132 × 75
Weight	282 g
Module-specific data	
Transfer rate	<ul style="list-style-type: none"> 10 Mbit/s for Ethernet services 100 Mbit/s full duplex for PROFINET IO
Transmission method	100BASE-TX
Send cycle	250 μs, 500 μs, 1 ms for IRT with the "high flexibility" or RT mode option 250 μs to 4 ms in increments of 125 μs for IRT with "high performance" option
Autonegotiation	Yes
Auto crossing	Yes
Internal switch function	Yes
Bus protocol	PROFINET IO
Supported Ethernet services	<ul style="list-style-type: none"> ping LLDP arp Net diagnostics (SNMP) / MIB-2
Maximum supported record length	<ul style="list-style-type: none"> 8192 bytes
PROFINET interface	4x RJ45
Manufacturer ID (vendor ID)	002A _H
Device ID (DeviceID)	0604 _H
Voltages, currents, potentials	
Rated supply voltage	DC 24 V (20.4 V ... 28.8 V)
<ul style="list-style-type: none"> Reverse polarity protection 	Yes
<ul style="list-style-type: none"> Power failure bypass 	Min. 5 ms
Electrical isolation of 24 V power supplies	
<ul style="list-style-type: none"> Between Ethernet and electronics 	Yes
<ul style="list-style-type: none"> Between power supply and electronics 	Incoming supply 1: No Incoming supply 2: Yes

A.2 General technical data

Dimensions and weight	
Ungrounded construction possible	Yes
Insulation tested at	DC 500 V
Current consumption from power supply (1L+)	Approx. 400 mA
Power loss	Approx. 6 mA
Status, interrupts, diagnostics	
Power supply status display	Yes
Interrupts	Yes
Diagnostic function	Yes
<ul style="list-style-type: none"> • Group fault for PROFINET IO subnet 1 • Group fault for PROFINET IO subnet 2 • Bus fault for PROFINET IO subnet 1 • Bus fault for PROFINET IO subnet 2 • Monitoring 24 V power supply PS1 • Monitoring 24 V power supply PS2 • PN/PN coupler in operation • Maintenance demand subnet 1 • Maintenance demand subnet 2 	<ul style="list-style-type: none"> • Red LED "SF1" • Red LED "SF2" • Red LED "BF1" • Red LED "BF2" • Green LED "PS1" • Green LED "PS2" • Green LEDs "ON1" and ON2" • Yellow "MT1" LED • Yellow "MT2" LED

A.2 General technical data

A.2.1 Introduction

Scope of the general technical data

The general technical data covers:

- The standards and test values that observe and fulfill the described components.
- The test criteria used to test the described components.

The general technical data for the following areas is provided below:

- Standards and approvals
- Electromagnetic compatibility
- Transport and storage conditions
- Mechanical and climatic ambient conditions for operation
- Specifications for insulation tests, safety class and degree of protection
- Rated voltage

A.2.2 Standards and approvals

CE approval



The PN/PN coupler satisfies the specifications and safety-related requirements of the following EC directives and is in line with the harmonized European standards (EN), which have been published in the Official Journals of the European Community for programmable logic controls:

- 73/23/EEC "Electrical Equipment for Use within Fixed Voltage Ranges" (Low-Voltage Directive)
- 89/336/EEC "Electromagnetic Compatibility" (EMC Directive)
- 94/9/EC "Equipment and Protective systems intended for use in Potentially Explosive Atmospheres" (Explosion Protection Directive)

The EU conformity declaration certificates are available for the responsible authorities and are kept at the following address:

Siemens AG
Automation and Drives
I IA AS RD ST Type Test
P.O. Box 1963
D-92209 Amberg

Approvals



Underwriters Laboratories Inc. complying with

- UL 508 (Industrial Control Equipment)
- CSA C22.2 No. 142 (Process Control Equipment)

or



Underwriters Laboratories Inc. complying with

- UL 508 (Industrial Control Equipment)
- CSA C22.2 No. 142 (Process Control Equipment)
- UL 1604 (Hazardous Location)
- CSA-213 (Hazardous Location)

APPROVED for use in
Class I, Division 2, Group A, B, C, D T4;
Class I, Zone 2, AEx nC, Group IIC T4

Note

The certifications currently valid can be found on the name plate of the specific module.

FM approval



Factory Mutual Research (FM) complying with Approval Standard Class Number 3611, 3600, 3810 APPROVED for use in Class I, Division 2, Group A, B, C, D T4; Class I, Zone 2, Group IIC T4



In accordance with EN 60079-15 (Electrical Apparatus for Potentially Explosive Atmospheres; Type of Protection "n")



II 3 G Ex nA II T4

Tick-Mark for Australia



The described components meet the requirements of the Norm AS/NZS 2064 (Class A) standard.

IEC 61131

The described components meet the requirements and criteria of the Norm IEC 61131-2 standard (programmable logic controls, part 2: equipment specifications and inspections).

Marine approval (will be requested)

Classification organizations:

- ABS (American Bureau of Shipping)
- BV (Bureau Veritas)
- DNV (Det Norske Veritas)
- GL (Germanischer Lloyd)
- LRS (Lloyds Register of Shipping)
- Class NK (Nippon Kaiji Kyokai)

PROFINET standard

The described components are based on the IEC 61158-6-10 standard.

Use in industrial environments

SIMATIC products are designed for use in industrial environments.

Operating range	Specification for	
	Radiated emission	Interference immunity
Industry	EN 61000-6-4:2001	EN 61000-6-2:2001

Use in residential areas

If you use the described components in residential areas, you must ensure limit class B as defined in EN 55011 for the emission of radio interference.

The following measures are appropriate for achieving the level of radio interference required for limit class B:

- Installation of grounded cabinets / control boxes
- Use of filters in supply lines

 WARNING
Personal injury and property damage can occur. Personal injury and property damage can occur in potentially explosive atmospheres if plug-in connections are disconnected during operation. Always de-energize all components in potentially explosive areas before disconnecting plug-in connections.

A.2.3 Electromagnetic compatibility

Introduction

This chapter provides you with information on the immunity to interference of the described components as well as on radio interference suppression.

The described components meet the requirements of the EMC legislation of the European Community.

Pulse-shaped disturbance variables

The table below shows the electromagnetic compatibility of the described components with regard to pulse-shaped disturbance variables. The prerequisite for this is that the system complies with the relevant requirements and guidelines relating to electrical equipment.

Table A- 1 Pulse-shaped disturbance variables

Pulse-shaped disturbance variable	Tested at	Corresponds to severity
Electrostatic discharge according to IEC 61000-4-2	8 kV	3 (air discharge)
	4 kV	2 (contact discharge)
Burst pulse (fast transients) complying with IEC 61000-4-4	2 kV (supply line) 2 kV (signal line)	3
Surge complying with IEC 61000-4-5 External protective network needed (see S7-300 Automation System, Hardware and Installation: CPU 312 IFM – 318-2 DP (http://support.automation.siemens.com/WW/view/en/15390415) Installation Manual, Chapter "Lightning protection and overvoltage protection")		
• Asymmetric coupling	2 kV (supply line) 2 kV (signal line / data line)	3
• Symmetric coupling	1 kV (supply line) 1 kV (signal line / data line)	

Sinusoidal disturbance variables

The table below shows the EMC characteristics of the described components with regard to sinusoidal disturbance variables.

Table A- 2 Sinusoidal disturbance variables

Sinusoidal disturbance variables	Test values	Corresponds to severity
HF irradiation (electromagnetic fields) according to IEC 61000-4-3	10 V/m at 80 % amplitude modulation of 1 kHz in the range from 80 MHz to 1000 MHz 10 V/m at 50 % pulse modulation at 900 MHz	3
HF current feed on lines and cable shields according to IEC 61000-4-6	Test voltage 10 V at 80 % amplitude modulation of 1 kHz in the range from 9 kHz to 80 MHz	3

Emission of radio interferences

Emission of interference from electromagnetic fields in compliance with EN 55011: limit class A, group 1.

from 30 to 230 MHz	< 30 dB (μV/m)Q
from 230 to 1000 MHz	< 37 dB (μV/m)Q
measured at a distance of 30 m	

Interference emitted via mains a.c. supply in accordance with EN 55011: limit class A, group 1.

from 0.15 to 0.5 MHz	< 79 dB (μV)Q < 66 dB (μV)M
from 0.5 to 5 MHz	< 73 dB (μV)Q < 60 dB (μV)M
from 5 to 30 MHz	< 73 dB (μV)Q < 60 dB (μV)M

A.2.4 Transport and storage conditions

Transport and storage of modules

In terms of transport and storage conditions, the described components exceed the requirements of IEC 61131 Part 2. The following details apply to modules which are transported or stored in their original packaging.

Table A- 3 Transport and storage conditions

Type of condition	Permitted range
Free fall (in transport packaging)	≤ 0.3 m
Temperature	between -40 °C and +70 °C
Atmospheric pressure	between 1080 and 660 hPa (corresponds to altitudes of 1000 m to 3500 m)
Relative humidity	from 10 to 95 %, without condensation
Sine-shaped vibrations complying with IEC 60068-2-6	5 - 9 Hz: 3.5 mm 9 - 150 Hz: 9.8 m/s ²
Shock complying with IEC 60068-2-29	250 m/s ² , 6 ms, 1000 shocks

A.2.5 Mechanical and climatic ambient conditions for operation

Operating conditions

The described components are designed for use in a fixed, sheltered location. The operating conditions exceed the requirements of IEC 61131 Part 2.

The described components meet the operating conditions of class 3C3 complying with DIN EN 60721 Part 2.

Operation with additional measures

The described components must **not** be used at the following locations without additional measures:

- Locations with a high level of ionizing radiation
- Locations with complicated operating conditions; e.g. due to
 - dust
 - caustic vapors and gases
 - strong electrical or magnetic fields
- Plants which require special monitoring, e.g.
 - elevators
 - electrical systems in particularly hazard-prone areas

An additional measure may be fitting in a cabinet or enclosure.

Mechanical ambient conditions

The mechanical ambient conditions for the described components are specified in the table below for sinusoidal vibrations.

Table A- 4 Mechanical ambient conditions

Frequency range in Hz	continuously	intermittently
$10 \leq f \leq 58$	0.0375 mm amplitude	0.075 mm amplitude
$58 \leq f \leq 150$	0.5 g constant acceleration	1 g constant acceleration

Reduction of vibrations

If the described components are exposed to greater shocks or vibrations, you must reduce the acceleration or the amplitude by taking suitable measures.

We recommend securing the described components to damping materials (e.g. to shock mounts).

Compatibility test, mechanical ambient conditions

The following table provides information about the type and scope of tests for mechanical ambient conditions.

Table A- 5 Compatibility test, mechanical ambient conditions

Testing for ...	Test standard	Remarks
Vibrations	Vibration test with IEC 60068 Parts 2-6 (sinus)	Type of vibration: Frequency cycles at a rate of change of 1 octave per minute. 10 Hz ≤ f ≤ 58 Hz, constant amplitude 0.075 mm 58 Hz ≤ f ≤ 150 Hz, constant acceleration 1 g Duration of vibration: 10 frequency cycles per axis in each of the 3 mutually perpendicular axes
Shock	Shock test complying with IEC 60068 Parts 2-29	Type of shock: Half-sine Strength of shock: 15 g peak value, 11 ms duration Direction of shock: 3 shocks each in the +/- direction in each of the 3 mutually perpendicular axes

Climatic ambient conditions

The described components may be operated under the following climatic ambient conditions:

Table A- 6 Climatic ambient conditions

Ambient conditions	Permitted range
Temperature: horizontal mounting all other mounting positions	from 0 to 60 °C from 0 to 40 °C
Relative humidity	between 19 and 95 %,
Atmospheric pressure	from 1080 hPa to 795 hPa
Contaminant concentration	SO ₂ : < 0.5 ppm; RH < 60 %, no condensation H ₂ S: < 0.1 ppm; RH < 60 %, no condensation

A.2.6 Specifications for insulation tests, safety class and degree of protection

Test voltages

The insulation stability is tested with the following voltages during product testing:

Table A- 7 Test voltages

Electric circuits with rated voltage U_e to other electric circuits or to earth	Test voltage
$0\text{ V} < U_e \leq 50\text{ V}$	DC 600 V, 1 s

Safety class

Safety class I in compliance with IEC 60536; this means that a grounding terminal to the mounting rail is required!

Protection against foreign bodies and water

Degree of protection IP 20 according to IEC 60529; that is protection against contact with standard probes.

There is no protection from penetration by water.

A.2.7 Rated voltage

Rated voltage for operation

The described components function with a rated voltage of 24 VDC. The tolerance range is DC 20.4 to 28.8 V.

Order numbers and accessories

B.1 Order numbers and accessories

Overview

Table B- 1 Order numbers for the PN/PN coupler

Components	Order number
PN/PN coupler	6ES7158-3AD01-0XA0
DIN rail 35 mm <ul style="list-style-type: none"> • 483 mm • 530 mm • 830 mm • 2000 mm 	<ul style="list-style-type: none"> • 6ES5710-8MA11 • 6ES5710-8MA21 • 6ES5710-8MA31 • 6ES5710-8MA41
SIMATIC Micro Memory Cards <ul style="list-style-type: none"> • SIMATIC Micro Memory Card 64k • SIMATIC Micro Memory Card 64k • SIMATIC Micro Memory Card 128k • SIMATIC Micro Memory Card 128k • SIMATIC Micro Memory Card 512k • SIMATIC Micro Memory Card 512k • SIMATIC Micro Memory Card 2M • SIMATIC Micro Memory Card 2M • SIMATIC Micro Memory Card 4M • SIMATIC Micro Memory Card 4M • SIMATIC Micro Memory Card 8M • SIMATIC Micro Memory Card 8M 	<ul style="list-style-type: none"> • 6ES7953-8LF11-0AA0 • 6ES7953-8LF20-0AA0 • 6ES7953-8LG11-0AA0 • 6ES7953-8LG20-0AA0 • 6ES7953-8LJ11-0AA0 • 6ES7953-8LJ20-0AA0 • 6ES7953-8LL11-0AA0 • 6ES7953-8LL20-0AA0 • 6ES7953-8LM11-0AA0 • 6ES7953-8LM20-0AA0 • 6ES7953-8LP11-0AA0 • 6ES7953-8LP20-0AA0
Industrial Ethernet FC RJ45 Plug 90 (RJ45 cable connector for Industrial Ethernet with rugged metal housing and integrated insulation piercing contacts for connection to Industrial Ethernet FC installation lines; with 90° cable outlet) <ul style="list-style-type: none"> • 1 item • 10 items • 50 items 	<ul style="list-style-type: none"> • 6GK1901-1BB20-2AA0 • 6GK1901-1BB20-2AB0 • 6GK1901-1BB20-2AE0
Industrial Ethernet Fast Connect installation cables <ul style="list-style-type: none"> • Fast Connect standard cable • Fast Connect trailing cable • Fast Connect marine cable 	<ul style="list-style-type: none"> • 6XV1840-2AH10 • 6XV1840-3AH10 • 6XV1840-4AH10

B.1 Order numbers and accessories

Components	Order number
Industrial Ethernet Fast Connect stripping tool	6GK1901-1GA00
200 color-coding plates per packaging unit (10 star-shaped supports in packs of 20 items per color) <ul style="list-style-type: none">• white• red• yellow• yellow-green• brown• blue• turquoise	<ul style="list-style-type: none">• 6ES7193-4LA20-0AA0• 6ES7193-4LD20-0AA0• 6ES7193-4LB20-0AA0• 6ES7193-4LC20-0AA0• 6ES7193-4LG20-0AA0• 6ES7193-4LF20-0AA0• 6ES7193-4LH20-0AA0

Dimensional drawings

C.1 PN/PN coupler dimensional drawing

Dimensional drawing

PN/PN coupler dimensional drawing (dimensions in mm):

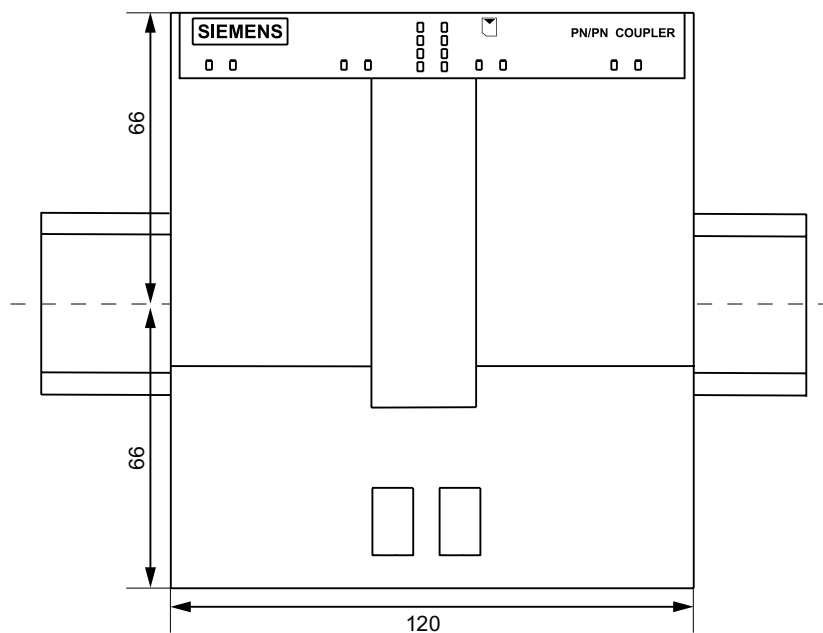

Glossary

Autonegotiation

Configuration protocol in Fast Ethernet. Before the actual data transfer, the devices on the network agree on a transfer mode that each participating device can work with (100 Mbps or 10 Mbps, full-duplex or half-duplex).

Bus

A common transfer route connecting all nodes and having two defined ends.

Bus connector

A physical connection between the bus node and the bus line.

Data record routing

Forwarding of data records beyond subnet boundaries from a sender to receivers via a router.

Device name

Before an IO Device can be addressed by an IO Controller, it must have a device name. This procedure was selected for PROFINET because names are easier to handle than complex IP addresses.

Assignment of a device name for a specific IO Device can be compared with the setting of the PROFIBUS address for a DP slave.

An IO Device does not have a device name upon delivery. Only once a device name has been assigned using the PG/PC, can an IO Device be addressed by an IO Controller, e.g. for the transmission of configuring data (including the IP address) during start-up or for the exchange of useful data in cyclic mode.

Device replacement without removable medium/programming device

IO Devices having this function can be replaced simply:

- A removable medium (such as Micro Memory Card) with the stored device name is not required.
- The device name does not have to be assigned using the programming device.

The replaced IO Device receives the device name from the IO Controller, not from the removable medium or from the programming device. For this purpose, the IO Controller uses the configured topology and the neighborhood relationships determined by the IO Devices. The configured setpoint topology must agree with the actual topology.

Diagnostics

Diagnostics is the detection, localization, classification, display and further evaluation of errors, faults, and messages.

Diagnostics provides monitoring functions that run automatically while the system is in operation. This increases the availability of systems by reducing setup times and downtimes.

Earth

The conductive earth whose electric potential can be set to zero at any point.

Electromagnetic compatibility (EMC)

Electromagnetic compatibility is understood as the ability of a piece of electrical equipment to function perfectly in a specified environment without impacting on its surroundings in an impermissible way.

Equipment, electrical

All components, power circuits or parts of power circuits that are normally to be found in one single enclosure.

Equipotential bonding

Electrical connection (equipotential bonding conductor) that brings the conductive parts of electrical equipment and other conductive parts to the same or approximately the same potential in order to prevent troublesome or dangerous voltages arising between these parts.

External lightning protection

External plant components at which galvanic coupling of lightning surges is excluded. Corresponds with lightning protection zone 0_A and 0_B .

Fast Ethernet

Fast Ethernet describes the standard for transmitting data at 100 Mbps. This transfer technology uses the 100 Base-T standard for this.

Firmware update

Updating of firmware of interface module

After (compatible) function extensions or after improvements to performance, the interface module can be updated to the latest firmware version.

Ground

The ground refers to all the interconnected inactive parts of a piece of equipment that, even in the event of a fault, cannot pick up voltage that is dangerous to touch.

Grounding

Grounding means connecting an electrically conductive part to a grounding system by means of the ground electrode.

GSD file

The properties of a PROFINET device are described in a GSD file (General Station Descriptor), which contains all the information required for configuration.

As with PROFIBUS, you can link a PROFINET device in STEP 7 by means of a GSD file.

In PROFINET IO, the GSD file is always in XML format. The structure of the GSD file corresponds to ISO 15734, the worldwide standard for device descriptions.

HW configuration

Part of STEP 7 for configuring hardware.

Industrial Ethernet

Industrial Ethernet (previously SINEC H1) is a technology that allows data to be transferred without interference in an industrial environment.

Due to the openness of PROFINET, you can use standard Ethernet components. We recommend, however, that you install PROFINET as Industrial Ethernet.

Isochronous real-time communication

Synchronized transmission method for the cyclic exchange of IRT data between PROFINET devices.

A reserved bandwidth is available within the send cycle for IRT IO data. The reserved bandwidth guarantees that IRT data can also be transferred at reserved, synchronized intervals while other, higher network loads are active (for example, TCP/IP communication, or additional real-time communication).

LAN

Local Area Network; interconnects multiple computers within a company. The geographical topology of a LAN is limited to the local premises and is only available to the operating company or institution.

MAC address

Each PROFINET device is assigned a worldwide unique device identifier in the factory. This 6-byte long device identifier is the MAC address.

The MAC address consists of:

- 3-byte manufacturer ID and
- 3-byte device ID (sequential number).

The MAC address is placed legibly on the front of the device
e.g.: 08-00-06-6B-80-C0

Parameterization

The term parameterization denotes the transfer of parameters from the IO Controller to the IO Device.

PELV

Protective Extra Low Voltage = extra low voltage with safe isolation

Power supply unit

A power supply unit supplies power to the field devices and the distributed process I/Os connected to them.

Prioritized startup

Prioritized startup denotes PROFINET functionality for accelerating the startup of IO Devices in a PROFINET IO system with RT and IRT communication. The function reduces the time that the correspondingly configured IO Devices require in order to return to the cyclic user data exchange in the following cases:

- After the supply voltage has returned
- After a station has returned
- After IO Devices have been activated

Process image

The process image is part of the IO Controller's system memory. The signal states of the input modules are transferred to the process-image inputs at the beginning of the cyclic program. At the end of the cyclic program, the process image of the outputs is transferred to the IO Controller as signal status.

PROFIBUS International

Technical committee dedicated to the definition and development of the PROFIBUS and PROFINET standard.

PROFINET

Within the context of Totally Integrated Automation (TIA), PROFINET is the systematic continuation of the following systems:

- PROFIBUS DP, the established fieldbus
- Industrial Ethernet, the communication bus for the cell level

Experiences from both systems have been and are being integrated in PROFINET.

PROFINET is an Ethernet-based automation standard of PROFIBUS International (previously PROFIBUS User Organization e.V.), and defines a multi-vendor communication, automation, and engineering model. PROFINET has been part of IEC 61158 since 2003.

See PROFIBUS International

PROFINET components

A PROFINET component includes all data of the hardware configuration, the parameters of the modules, and the associated user program. The PROFINET component comprises the following elements:

- Technological function
The (optional) technological (software) function includes the interface to other PROFINET components as interconnectable inputs and outputs.
- Device
The device represents the physical automation device or field device, including the IO, sensors and actuators, mechanical system, and device firmware.

PROFINET device

A PROFINET device always has at least one Industrial Ethernet port. Additionally, a PROFINET device can have a PROFIBUS connection: as master with proxy functions. In exceptions, a PROFINET device can also have a several PROFIBUS connections (for example CP 5614).

PROFINET IO Controller

Device by means of which connected IO Devices are addressed. In other words: The IO Controller exchanges input and output signals with the assigned field devices. The IO Controller is often the controller in which the automation program is executed.

PROFINET IO

Within the context of PROFINET, PROFINET IO is a communication concept for implementing modular, distributed applications.

PROFINET IO allows you to create automation solutions familiar from PROFIBUS.

Implementation of PROFINET IO is carried out on the one hand via the PROFINET standard for automation devices and on the other by using the engineering tool STEP 7.

This means that you have the same application layer in STEP 7 – regardless of whether you configure PROFINET devices or PROFIBUS devices. The programming of your user program is identical for PROFINET IO and PROFIBUS DP when you use the blocks and system status lists expanded for PROFINET IO.

PROFINET IO Device

Distributed field device which is assigned to one of the IO Controllers (e.g. remote IO, valve terminals, frequency converter, switches).

Reference potential

Potential that is used to view and/or measure voltages for each circuit involved.

SELV

Safety extra low voltage (SELV) is voltage ≤ 30 V AC/60 V DC that is generated via a safety transformer or accumulator.

SNMP

SNMP (Simple Network Management Protocol) is the standardized protocol, for diagnosing and also configuring the Ethernet network infrastructure.

In the office setting and in automation engineering, devices from many different manufacturers support SNMP on the Ethernet.

SNMP-based applications can be operated on the same network in parallel to applications with PROFINET.

The scope of the supported functions differs depending on the device type. For example, a switch has more functions than a CP 1616.

Switch

PROFIBUS is a linear network. The communication nodes are connected with one another by means of a passive line - the bus.

By contrast, the Industrial Ethernet consists of point-to-point connections: each communication node is directly connected to exactly one communication node.

If a communication node is connected with several communication nodes, this communication node is connected to the port of an active network component - the switch. Additional communication nodes (including switches) can now be connected to the other ports of the switch. The connection between a communication node and the switch remains a point-to-point connection.

A switch also has the task of regenerating and distributing received signals. The switch "learns" the Ethernet address(es) of a connected PROFINET device or other switches and only forwards signals, which are destined for the connected PROFINET device or the connected switch.

A switch has a specific number of ports. You connect at most one PROFINET device or additional switch to each port.

TN-S system

In a TN-S system, the neutral conductor (N) and protective conductor (PE) are wire with separate insulation. The neutral conductor is connected to the grounded protective conductor at a central point, and only there. The protective conductor can be grounded any number of times.

Transmission rate

The transmission rate specifies the number of bits transmitted per second.

ungrounded

Having no conductive connection to earth

User data flag

Each IO module is assigned a value in the input or output data message; this value provides a statement on the quality of this user datum. For example, outputs of a specific module can be switched off by means of this without affecting other modules.

Index

2

24 V DC power supply, 21

A

Accessories, 79

Alarm

Maintenance alarm, 58

Ambient conditions

climatic, 77

mechanical, 76, 77

Operation, 76

Transport and storage, 75

Appearance, 12

Application, 9

Approval

CE, 71

CSA, 71

FM, 72

UL, 71

Approvals, 3

Assembly, 16

Assembly rules

Mounting position, 15

Australian mark, 72

Auto negotiation

Fixed port setting, 36

B

Basic knowledge, 3

BF (LED), 53

Boundary conditions, 40

C

Cable, 79

CE approval, 71

CE mark, 4

Climatic ambient conditions, 77

Color-coding plates, 17, 79

Commissioning, 38

Components for assembly, 16

Configuration, 11

Configuring, 11

Example, 31

Overview, 27

with another configuring tool, 33

with GSD file, 33

with STEP 7, 28

Connections, 22

construction

Ungrounded, 19

Contacts, 4

CSA approval, 71

C-Tick, 4

D

Data record module

RD READ, 40

RD WRITE, 40

Data record transfer, 39

Status information, 41

Degree of protection, 78

Device replacement without removable

medium/programming device, 36

Diagnostic data records

Manufacturer-specific, 60

Diagnostic interrupt, 58

Diagnostics

after recovery of the IO device, 68

after STOP IO controller, 68

Example, 62

Manufacturer-specific diagnostic data records, 60

Dimensional drawing, 81

DIN rail, 16, 79

Disassembly, 16

Display elements, 12, 53

Disposal, 4

disturbance variables

Pulse-shaped, 74

sinusoidal, 74

E

Electrical isolation, 19

Electrical properties, 19

Electromagnetic compatibility, 73

EMERGENCY STOP equipment, 20

Equipment
 open, 15
Error displays, 53
Example of configuring, 11
Exchange
 defective PN/PN coupler, 49

F

Factory settings
 Delivery condition, 37
 Resetting to, 37
Firmware update
 Prioritized startup, 35
FM approval, 72
Function, 9

G

Grounding, 19
GSD file, 33
Guide through the manual, 4

I

Identification data, 50
IEC 61131, 72
industrial environments
 Use in, 72
Information landscape, 4
Insulation test, 78
Internet address, 4
Interrupt
 Diagnostic interrupt, 58
 ReturnOfSubmodule interrupt, 58
 Update interrupt, 58
IRT
 Isochronous real-time communication, 35

L

LEDs, 53
Lightning protection
 24 V DC power supply, 21
LINK (LED), 53

M

Maintenance alarm, 58
Manual purpose, 3

Manuals
 Other important manuals, 4
Marine type approval, 72
Mechanical ambient conditions, 77
Module replacement, 49
Mounting position, 15

N

Newsletter, 5

O

OB 56, 41
 Update interrupt, 41
ON (LED), 53
Operating conditions, 76
Order numbers, 79

P

Parameterization, 11
PN/PN coupler
 Assembling, 16
 disassembling, 16
 replace, 49
Power supply
 Connecting, 23
 Two-way, 23
Principle of operation, 9
PROFINET IO
 Cable, 79
 Connecting, 25
 Standard, 72
Properties, 13, 19
Purpose of manual, 3

R

Radio interferences
 Emission of, 75
Rated voltage, 78
RD READ, 40
RD WRITE, 40
Reading out the diagnostic data
 Options, 60
Recovery of the IO device
 Diagnostics events triggered, 68
Recycling, 4
residential areas

Use in, 73
Response times, 45
 Influencing factors, 45
ReturnOfSubmodule interrupt, 58
Revisions, 3
RX/TX (LED), 53

S

Safety class, 78
Scope, 3
Service, 5
SF (LED), 53
SIMATIC Micro Memory Card, 46
 Applicable SIMATIC Micro Memory Cards, 46
 Lifetime, 46
 Slot, 12, 13
SNMP, 37
Standards, 4, 71
Status and fault displays
 LEDs, 54
Status displays, 53
Status information
 Data record transfer, 41
STEP 7
 Diagnostics, 60

STOP IO controller
 Diagnostics events triggered, 68
Support on the Internet, 5

T

Technical data, 69
Technical setup, 15
Test voltages, 78
Training, 5
Two-way power supply, 23

U

UL approval, 71
Ungrounded construction, 19
Update interrupt, 39, 41, 58
Updating firmware
 SIMATIC Micro Memory Card, 48
Use
 in industrial environments, 72
 in residential areas, 73

V

Vibrations, 76