

SINAMICS IOP

Intelligent Operator Panel

Operating Instructions · March 2013



SINAMICS

SIEMENS

SIEMENS

SINAMICS

SINAMICS G120, SINAMICS G120C Intelligent Operator Panel (IOP)

Operating Instructions

<u>Safety notes</u>	1
<u>Overview</u>	2
<u>Installation</u>	3
<u>Wizards</u>	4
<u>Control</u>	5
<u>Menu</u>	6
<u>Options</u>	7
<u>Technical data</u>	8

Edition 03/2013, Firmware IOP V1.4



03/2013, FW V1.4

A5E00110011A4 AB

Legal information

Warning notice system

This manual contains notices you have to observe in order to ensure your personal safety, as well as to prevent damage to property. The notices referring to your personal safety are highlighted in the manual by a safety alert symbol, notices referring only to property damage have no safety alert symbol. These notices shown below are graded according to the degree of danger.

 DANGER
indicates that death or severe personal injury will result if proper precautions are not taken.
 WARNING
indicates that death or severe personal injury may result if proper precautions are not taken.
 CAUTION
indicates that minor personal injury can result if proper precautions are not taken.
NOTICE
indicates that property damage can result if proper precautions are not taken.

If more than one degree of danger is present, the warning notice representing the highest degree of danger will be used. A notice warning of injury to persons with a safety alert symbol may also include a warning relating to property damage.

Qualified Personnel

The product/system described in this documentation may be operated only by **personnel qualified** for the specific task in accordance with the relevant documentation, in particular its warning notices and safety instructions. Qualified personnel are those who, based on their training and experience, are capable of identifying risks and avoiding potential hazards when working with these products/systems.

Proper use of Siemens products

Note the following:

 WARNING
Siemens products may only be used for the applications described in the catalog and in the relevant technical documentation. If products and components from other manufacturers are used, these must be recommended or approved by Siemens. Proper transport, storage, installation, assembly, commissioning, operation and maintenance are required to ensure that the products operate safely and without any problems. The permissible ambient conditions must be complied with. The information in the relevant documentation must be observed.

Trademarks

All names identified by ® are registered trademarks of Siemens AG. The remaining trademarks in this publication may be trademarks whose use by third parties for their own purposes could violate the rights of the owner.

Disclaimer of Liability

We have reviewed the contents of this publication to ensure consistency with the hardware and software described. Since variance cannot be precluded entirely, we cannot guarantee full consistency. However, the information in this publication is reviewed regularly and any necessary corrections are included in subsequent editions.

Table of contents

1	Safety notes	7
1.1	Warnings and cautions	7
2	Overview	9
2.1	Introduction	9
2.2	Layout and functions	10
2.3	Screen icons	12
2.4	Menu structure	13
3	Installation	15
3.1	Fitting the IOP	15
3.2	Initial Set-up	16
4	Wizards	21
4.1	Example wizard	29
4.1.1	Basic commissioning with IOP	29
4.1.2	Basic commissioning with IOP and P0015 Macros	34
4.1.3	Pre-assignment of IOs and wiring for P0015 Macros	38
4.1.4	Wiring diagrams	43
5	Control	53
6	Menu	57
6.1	Overview	57
6.2	Diagnostics.....	58
6.3	Parameters.....	62
6.4	Up/Download.....	68
6.5	Extras	69
6.6	Write Protection.....	78
6.7	Know-how Protection	81
7	Options	95
7.1	Door mounting kit	95
7.2	Hand-held device	97
8	Technical data	101
8.1	Technical specifications	101
	Index	103

Safety notes

1.1 Warnings and cautions

 WARNING
<ul style="list-style-type: none">• During commissioning of the Inverter it is essential to ensure that the system is in a safe and stable state, as some commissioning processes have the potential to start the motor. Therefore it is important to secure any loads and ensure that should the motor start, no potentially dangerous conditions exist.• The IOP can be fitted to and removed from the inverter while power is applied.• The IOP will set the USS PZD (P2012) length to 4 when connected to the inverter.

Overview

2.1 Introduction

The Intelligent Operator Panel (IOP) has been designed to enhance the interface and communications capabilities of SINAMICS Inverters.

The IOP connects to the Inverter through an RS232 interface. It has been designed to automatically recognise the following devices from the SINAMICS range:

- SINAMICS ET200 PRO*
- SINAMICS ET200S*
- SINAMICS G110D*
- SINAMICS G120 CU230P-2
- SINAMICS G120 CU240B-2
- SINAMICS G120 CU240E
- SINAMICS G120 CU240E-2
- SINAMICS G120 CU240S
- SINAMICS G120 CU250S-2
- SINAMICS G120C
- SINAMICS G120D-2 CU240D-2*
- SINAMICS G120D-2 CU250D-2*
- SINAMICS S110 CU305*

*Denotes Control Units that require the IOP Hand-Held Kit to connect the IOP to the Control Unit.

Hand-Held Kit order number: 6SL3255-0AA00-4HA0.

Optical cable order number: 3RK1922-2BP00

The IOP provides support, using the USB connection utilizing a PC for the following functions:

- Downloading of wizards
- Downloading additional languages
- Downloading of IOP firmware updates

The downloads can be found by searching the Siemens Service and Support website:

Service & Support website (<http://support.automation.siemens.com>)

Note

IOP functional support

- Drives with SINAMICS firmware prior to version 4.2 may not be fully supported by the IOP.
- The actual menu structure and functionality of the IOP will be influenced by the following factors:
 - The software version and type of Control Unit to which the IOP is fitted.
 - The firmware and software version of the IOP.
 - The selected functional group filtering of the parameters.

2.2 Layout and functions

The physical layout of the IOP is shown below:

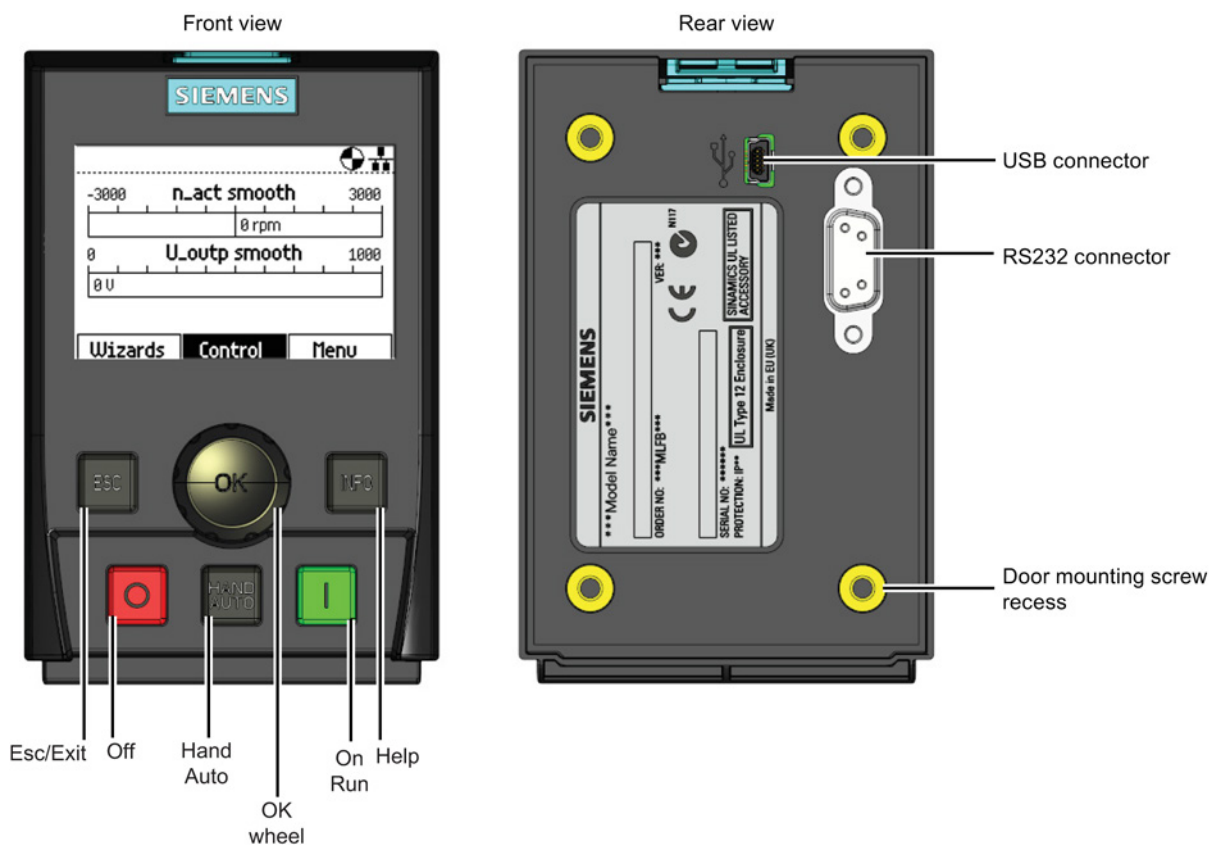







Figure 2-1 Layout of IOP

The IOP is operated by using a push-wheel and five additional buttons. The specific functions of the push-wheel and buttons are shown in the table below.

Table 2- 1 Function of the IOP controls

Key	Function
	<p>The push-wheel has the following functions:</p> <ul style="list-style-type: none"> In a menu, turning the push-wheel changes the selection. When a selection is highlighted, pressing the push-wheel confirms the selection. When editing a parameter, turning the push-wheel changes the displayed value; clockwise increases the value and anti-clockwise decreases the displayed value. When editing parameter or search values there is a choice to edit individual digits or an entire value. With a long press of the push-wheel (>3 sec) it will toggle between the two different value editing modes.
	<p>The ON key has the following functions:</p> <ul style="list-style-type: none"> In AUTO mode, the screens displays an information screen, stating that the command sources is AUTO and can be changed by pressing the HAND/AUTO KEY. In HAND mode the Inverter is started - the Inverter status icon starts turning. <p>Notes:</p> <p>For Control Units with firmware versions less than 4.0: When running in AUTO mode, HAND mode cannot be selected unless the Inverter is stopped.</p> <p>For Control Units with firmware versions 4.0 or greater: When running in AUTO mode, HAND mode can be selected and the motor will continue to run at the last selected setpoint speed.</p> <p>When the Inverter is running in HAND mode, the motor stops when switched to AUTO.</p>
	<p>The OFF key has the following functions:</p> <ul style="list-style-type: none"> If pressed for longer than 3 seconds the Inverter will perform an OFF2; the motor will then coast down to a standstill. Note: 2 presses of the OFF key within 3 seconds will also perform and OFF2. If pressed for less than 3 seconds the following actions will be performed: <ul style="list-style-type: none"> If in AUTO mode the screen will display an information screen stating that the command sources is AUTO and can be changed using the HAND/AUTO key. The Inverter will not be stopped. If in HAND mode the Inverter will perform an OFF1; the motor will come to a standstill in the ramp-down time set in parameter P1121.
	<p>The ESC key has the following functions:</p> <ul style="list-style-type: none"> If pressed for less than 3 seconds the IOP returns to the previous screen or if a value has been edited, the new value is not saved. If pressed longer than 3 seconds the IOP returns to the status screen. <p>When using the ESC key in the parameter editing mode, no data is saved unless the OK key is pressed first.</p>
	<p>The INFO key has the following functions:</p> <ul style="list-style-type: none"> Displays additional information for the currently selected item. Pressing the INFO key again will display the previous screen. Pressing the INFO key during power-up of the IOP will place the IOP in DEMO mode. To exit DEMO mode, power-cycle the IOP.
	<p>The HAND/AUTO key switches the command source between HAND and AUTO mode.</p> <ul style="list-style-type: none"> HAND sets the command source to the IOP. AUTO sets the command source to an external source, for example, fieldbus.

DEMO mode

DEMO mode allows the IOP to be used for demonstration purposes without affecting the Inverter to which it is connected. Menus can be navigated and functions selected, but all communications with the Inverter are blocked to ensure that the Inverter does not react to any commands issued from the IOP.

Locking and unlocking the keypad

To lock the IOP keypad press **ESC** and **INFO** simultaneously for 3 seconds or more. To unlock the keypad press **ESC** and **INFO** simultaneously for 3 seconds or more.

2.3 Screen icons

The IOP displays a number of icons at the top right-hand edge of the display to indicate various states or current conditions of the Inverter. These icons are explained in the table below.

Table 2- 2 Screen icons

Function	Status	Icon	Remarks
Command source	Auto		
	JOG	JOG	Displayed when the JOG function is active.
	Hand		
Inverter status	Ready		
	Running		Icon rotates when the motor is running
Fault pending	Fault		
Alarm pending	Alarm		
Saving to RAM	Active		Indicates all data is currently saved to RAM. If power is terminated all data is lost.
PID autotuning	Active		
Hibernation mode	Active		
Write Protection	Active		Parameters cannot be modified.
Know How Protection	Active		Parameters cannot be viewed or modified.
ESM	Active		Essential Services Mode
Battery condition	Fully charged		The battery status is only shown when the IOP Hand-held kit is used.
	¾ charged		
	½ charged		
	¼ charged		
	No charge		
	Charging		

2.4 Menu structure

The IOP is a menu-driven device and has the following menu structure:

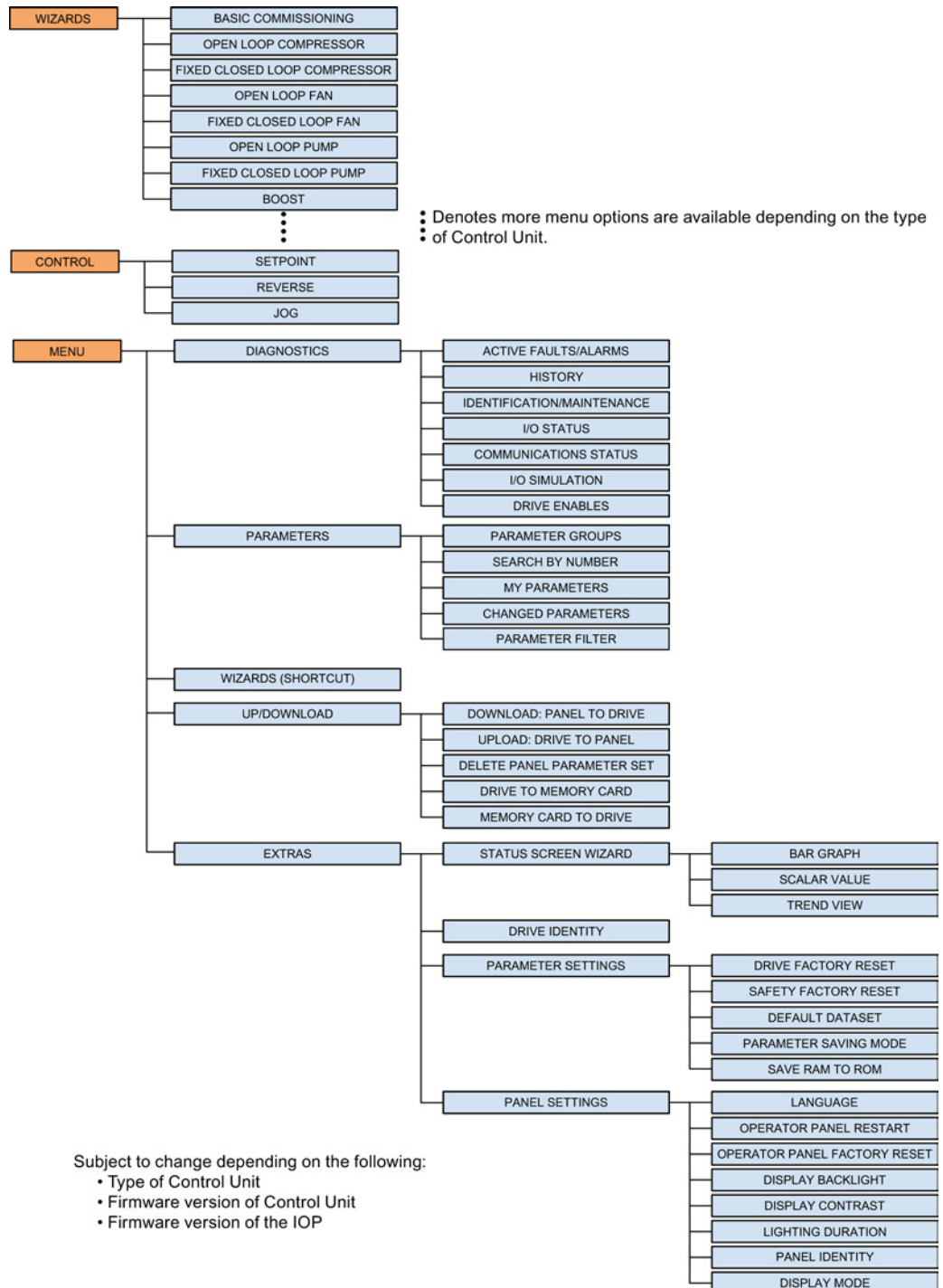



Figure 2-2 IOP menu structure

Installation

3.1 Fitting the IOP

Fitting the IOP to the Control Unit

 CAUTION
IOP power supply
The IOP has no internal power supply and derives its power directly from the Control Unit of the Inverter through the RS232 interface. The IOP can also be connected to a PC and derives its power through the USB connection.

To fit the IOP to the Inverter Control Unit the following procedure should be performed:

1. Place the bottom edge of the IOP casing into the lower recess of the Control Unit housing.
2. Push the IOP forward until the top fastening clicks into place on the Control Unit housing.



Figure 3-1 Fitting the IOP to the Control Unit

3.2 Initial Set-up

Initial Set-up

Once the IOP is fitted and powered-up it will automatically detect the type of Control Unit and Power Module to which it has been fitted. On first-time use, the IOP automatically displays the option to select the default language and allow the time and date to be set (if the Control Unit to which the IOP is fitted has a real-time clock).

After the initial start-up screen has been displayed, the IOP will then display details of the type of Control Unit and Power module, including the orders numbers.

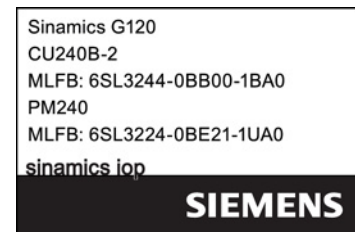
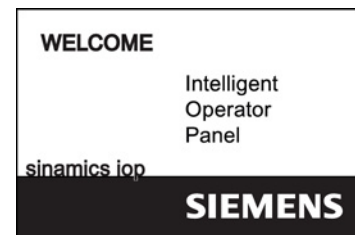

After the Identification screen has been displayed the Language selection screen will be displayed.

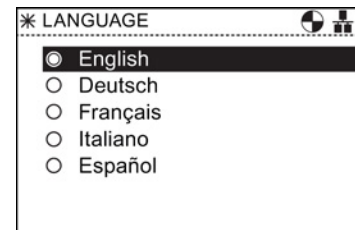

Once the language is selected - the Wizard menu is displayed.

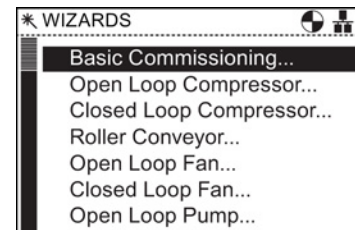

If the Wizard menu is not required, then press Esc to return to the normal status screen.

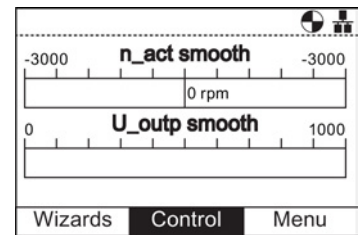

Language selection

To select the language that the IOP should display, the following actions should be performed:

1. Rotate the **Wheel** to select "**Menu**".
2. Press the **Wheel** to confirm selection.
3. The "**Menu**" screen is displayed.
4. Rotate the **Wheel** to select "**Extras**".
5. Press the **Wheel** to confirm selection.
6. The "**Extras**" screen is displayed.
7. Rotate the **Wheel** to select "**Panel Settings**".
8. Press the **Wheel** to confirm selection.
9. Rotate the **Wheel** to select the required language.
10. Press the **Wheel** to confirm selection.
11. The "Language" screen is displayed.
12. Rotate the **Wheel** to select the language.
13. Press the **Wheel** to confirm selection.
14. The selected language will now be used by the IOP.
15. The IOP will return to the "**Extras**" menu.
16. Press "**Esc**" for more than 3 seconds to return to the "**Status**" screen.

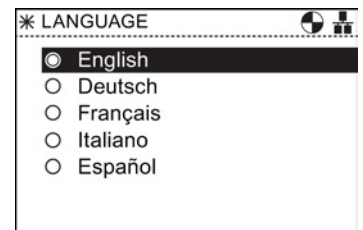
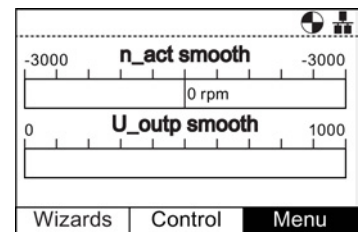

The number of available languages will vary depending upon the languages that have been added or deleted by the user and the software version of the IOP.

Setting time and date

When the IOP is first fitted to a Control Unit, which has a real-time clock, it will automatically display the time and date screen, the following actions should be performed:

1. The "**Time and Date**" screen is displayed.
2. Rotate the **Wheel** to change the value.
3. Press the **Wheel** to confirm the value and move to the next field.
4. Rotate the **Wheel** to change the value.
5. Press the **Wheel** to confirm value and move to the next field.
6. Continue the process for the date fields.
7. When the last field of the date is completed, the screen will return to the "**Extras**" menu.
8. Press "**Esc**" for more than 3 seconds to return to the "**Status**" screen.

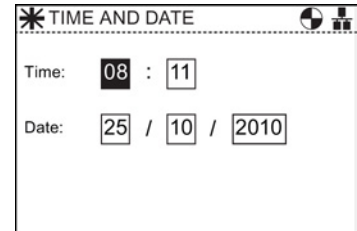

The settings for time are normally done on the Control Unit if it has a Real-time Clock (RTC). If the Inverter has an RTC the IOP will take its settings from the Control Unit.

Lighting duration

To set the length of time that the display remains lit, the following actions should be performed:

1. Rotate the **Wheel** to select "**Menu**".
2. Press the **Wheel** to confirm selection.
3. The "**Menu**" screen is displayed.
4. Rotate the **Wheel** to select "**Extras**".
5. Press the **Wheel** to confirm selection.
6. The "**Extras**" screen is displayed.
7. Rotate the **Wheel** to select "**Panel Settings**".
8. Press the **Wheel** to confirm selection.
9. Rotate the **Wheel** to selected "**Lighting duration**".
10. Press the **Wheel** to confirm selection.
11. The "**Lighting duration**" screen is displayed.
12. Rotate the **Wheel** to select the required lighting duration.
13. Press the **Wheel** to confirm selection.
14. The display returns to the "**Extras**" menu.
15. Press "**Esc**" for more than 3 seconds to return to the "**Status**" screen.

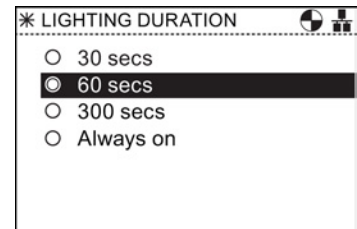

Display contrast

To set the contrast level of the IOP, the following actions should be performed:

1. Rotate the **Wheel** to select "**Menu**".
2. Press the **Wheel** to confirm selection.
3. The "**Menu**" screen is displayed.
4. Rotate the **Wheel** to select "**Extras**".
5. Press the **Wheel** to confirm selection.
6. The "**Extras**" screen is displayed.
7. Rotate the **Wheel** to select "**Panel Settings**".
8. Press the **Wheel** to confirm selection.
9. Rotate the **Wheel** to selected "Display contrast".
10. Press the **Wheel** to confirm selection.
11. The "**Display contrast**" screen is displayed.
12. Rotate the **Wheel** to select the required contrast setting.
13. Press the **Wheel** to confirm selection.
14. The display returns to the "**Extras**" menu.
15. Press "**Esc**" for more than 3 seconds to return to the "**Status**" screen.

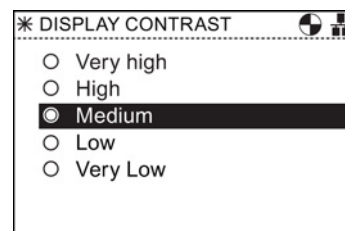

Display backlight

To change the intensity of the backlight, the following actions should be performed:

1. Rotate the **Wheel** to select "**Menu**".
2. Press the **Wheel** to confirm selection.
3. The "**Menu**" screen is displayed.
4. Rotate the **Wheel** to select "**Extras**".
5. Press the **Wheel** to confirm selection.
6. The "**Extras**" screen is displayed.
7. Rotate the **Wheel** to select "**Panel Settings**".
8. Press the **Wheel** to confirm selection.
9. Rotate the **Wheel** to selected "**Display backlight**".
10. Press the **Wheel** to confirm selection.
11. The "**Display backlight**" screen is displayed.
12. Rotate the **Wheel** to select the required brightness setting.
13. Press the **Wheel** to confirm selection.
14. The display returns to the "**Extras**" menu.
15. Press "**Esc**" for more than 3 seconds to return to the "**Status**" screen.

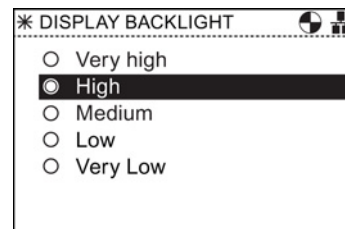

Display mode

To change the display mode, the following actions should be performed:

1. Rotate the **Wheel** to select "**Menu**".
2. Press the **Wheel** to confirm selection.
3. The "**Menu**" screen is displayed.
4. Rotate the **Wheel** to select "**Extras**".
5. Press the **Wheel** to confirm selection.
6. The "**Extras**" screen is displayed.
7. Rotate the **Wheel** to select "**Panel Settings**".
8. Press the **Wheel** to confirm selection.
9. Rotate the **Wheel** to selected "**Display mode**".
10. Press the **Wheel** to confirm selection.
11. The "**Display mode**" screen is displayed.
12. Rotate the **Wheel** to select the required setting.
 - "Normal" displays white text on a black background.
 - "Inverse" displays black text on a white background.
13. Press the **Wheel** to confirm selection.
14. The display returns to the "**Extras**" menu.
15. Press "**Esc**" for more than 3 seconds to return to the "**Status**" screen.

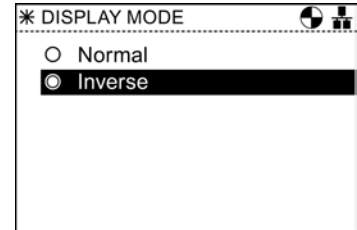

Wizards

Overview

The IOP wizards are question-driven macros that assist the user to set-up various functions and applications of the Inverter.

 **WARNING**

Commissioning the Inverter

During commissioning of the Inverter it is essential to ensure that the system is in a safe and stable state, as some commissioning processes have the potential to start the motor. Therefore it is important to secure any loads and ensure that should the motor start, no potentially dangerous conditions exist.

Datasets

The wizards use the default Drive Datasets (DDS0 and CDS0), if the default datasets are changed to the other datasets available, the wizards may not function correctly.

Wizards

There are several wizards which allow the user to set-up various functions and commission the Inverter. An example of the type of wizards are given below:

- Basic commissioning
- Open Loop Compressor
- Closed Loop Compressor
- Roller Conveyor
- Open Loop Fan
- Closed Loop Fan
- Open Loop Pump
- Closed Loop Pump
- Safety Commissioning
- PID
- Boost

The following is an outline of the various wizards; the relevant wiring diagrams, if required are contained in the "Wiring diagrams" section in this chapter.

Note

Wizards

The actual menu structure and the functionality of the IOP will be influenced by the following factors:

- The software version and type of Control Unit to which the IOP has been fitted.
- The firmware and software version of the IOP.
- The Roller conveyor wizard requires a fieldbus compatible Control Unit (PROFIBUS/PROFINET).

SINAMICS ET200S (Pro) and SINAMICS G120D Inverters

The Roller conveyor wizard is the only application wizard available for SINAMICS ET200S (Pro) and SINAMICS G120D Inverters.

Accessing the IOP wizards

Wizards are accessed from the wizards menu, at the bottom-left of the Status screen as shown in the figure below.

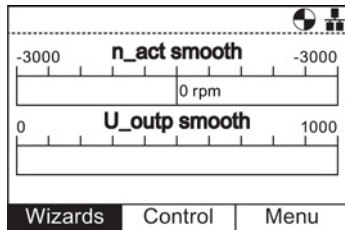

Figure 4-1 Status screen with Wizard menu highlighted

Prerequisites

Note

Factory reset

A factory reset option is offered by each wizard. It is highly recommended that the factory reset option is accepted.

The user must ensure that all the following actions have been completed prior to using the IOP application wizards:

- All necessary equipment is available and installed correctly, according to the relevant wiring diagram for the specific application wizard.
- All wiring of the Inverter, motor and any other devices used within the application has been completed in accordance with the wiring diagrams included in the appropriate section of this manual.
- All components of the system have been tested to ensure their correct and safe installation.

Information requested by the wizards

Since the IOP wizards will request detailed technical information during the setting-up process, it is important to have this information available. This information can be obtained from the following sources:

- **Motor data** - this data is obtained from the motor rating plate. See figure below.
- **Sensor data** - details of the types of sensors that may be used with the Inverter, such as temperature sensors and pressure sensors. The required information is normally found on the rating label of the sensor.

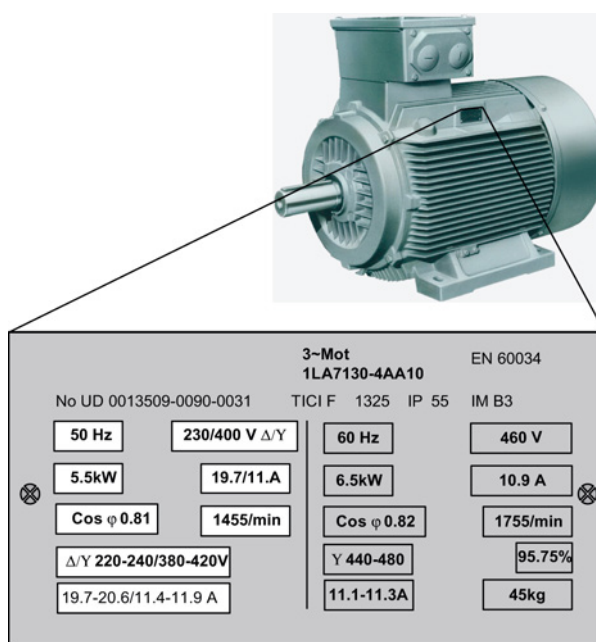

Figure 4-2 Typical motor rating plate

Boost

At low output frequencies, the V/f characteristics give only a low output voltage. This means that the output voltage can be too low in order to:

- Implement the magnetization of an induction motor
- to hold the load
- to equalize losses in the system
- to provide a breakaway, acceleration or braking torque.

The output voltage can be increased (boosted) in the Inverter using the boost function. The Boost settings wizard guide the user through the correct setting of the boost function.

Open-loop fan

This is a basic fan application where the fan is under the control of the Inverter.

The system comprises of the following components:

- Control Module
- Power Module
- Motor
- Fan
- Belt monitoring sensor (optional)
- Motor temperature sensor (optional)

Basic commissioning

The basic commissioning of the Inverter and motor comprises a number of processes. The processes are as follows:

- Quick commissioning
- Vector control mode
- Calculation of motor and control data

The wizard will guide the user through the basic commissioning process by presenting a number of screens where the user can choose the necessary options and values to commission the Inverter and motor. At the conclusion of the basic commissioning process, the data can be saved to the Inverters memory.

PID controller

Closed-loop control is widely used in industrial applications to control a wide variety of processes. A simple closed-loop control uses a feedback signal from the process (such as, temperature, pressure and speed) and a desired value or setpoint. The control system compares the two values and derives an error signal. The error signal is used to control the Inverter and motor to reduce the error.

The error signal processing can be very complex because of the delays in the system. The error signal is processed using a Proportional and Integral differential (PID) controller whose parameters can be adjusted to optimize the performance and stability of the system.

The PID controller wizard guide the user through the PID setting-up process.

Open-loop pump

The purpose of this application is to maintain a constant level of fluid in a pumping system and reacting to maintain the pre-determined level even if fluid is being drawn from the system.

The analog input is used to set the frequency setpoint.

The system comprises the following components:

- Control Module
- Power Module
- Motor
- Pump
- Motor temperature sensor (optional)
- Level sensor (dry run protection - optional).

Closed-loop compressor

A constant pressure is required to be maintained within a system utilizing the minimum use of energy.

The pressure in the system is monitored using the PID controller and if the pressure remains constant then the Inverter will run the system at the minimum frequency to maintain the pressure.

The setpoints are controlled by analog input 0.

The feedback from the system are received from the pressure sensor utilizing analog input 1. This feedback is then used by the Inverter to react to changes in the system pressure.

The on/off and reset commands are controlled using digital inputs 0 and 1 respectively.

The general monitoring of the condition of the Inverter is achieved using digital outputs 0, 1 and 2 for drive failure, drive ready and drive running respectively.

The system will comprise of the following components:

- Control Module
- Power Module
- Motor
- Compressor
- Pressure sensor
- Motor temperature sensor (optional).

Closed-loop pump

The closed-loop application allows for the fluid in a tank to be directly monitored using the PID control function.

The system comprises the following components:

- Control Unit
- Power Module
- Motor
- Pump

- Feedback sensor
- Level sensor (dry run protection - optional)
- Motor temperature sensor (optional).

Closed-loop fan

The purpose of the closed-loop controlled fan application is to maintain a constant airflow within a ventilation system, utilizing as little energy as possible.

A specific airflow and pressure for the fan system is set within the Inverter and these values are directly monitored using the PID controller. Depending on a decrease or increase in pressure readings, the Inverter will increase or decrease the speed of the fan accordingly.

The system comprises the following components:

- Control Module
- Power Module
- Motor
- Fan
- Feedback sensor
- Motor temperature sensor (optional).

Roller conveyor

This wizard can be used for the typical material handling applications, such as conveyor belts, roller conveyors and turn-tables.

The sensors are directly connected to the Inverter to allow their individual status to be sent to the controlling PLC.

The system will comprise of the following components:

- Control Module (with fieldbus interface)
- Power Module
- Geared motor
- Initiators (digital)
- Mechanical brake
- Motor temperature sensor (optional).

Open-loop compressor

The Inverter is used to control the output pressure of a compressor to ensure that it adapts to the varying volume of gas that is required to be compressed.

Compressing the gas involves reducing the volume and increasing the pressure within the container to compress the gas.

The setpoint is controlled by the analog inputs.

The system comprises of the following components:

- Control Module
- Power Module
- Motor
- Compressor
- Motor temperature sensor (optional).

Fan staging with PID

this application is used to run several fans in parallel depending on the actual airflow requirement.

One fan is under direct control and monitoring of the Inverter, the other fans are started and stopped as required, but no feedback from the other fans is required. The monitoring is performed by the use of pressure sensors utilizing the PID controller.

The analog inputs are used for setting the setpoint and receiving the feedback from the various sensors, to which the PID control will react. The digital outputs are used to control the fans.

Each fan, when started is ran at the minimum frequency; this is done to achieve a uniformed increase in pressure/airflow without causing a surge in pressure within the system.

Since all fans have the ability to be started and stopped by the Inverter, it is possible to use the fans in a different number of sequences to ensure that no one fan is working permanently and the workload is distributed in a balanced manner.

The system comprises of the following components:

- Control Module
- Power Module
- Motor
- Multiple fans
- Pressure sensors
- Temperature sensor (optional)

Pump staging with PID

This application is designed to operate a number of pumps in parallel depending on the required demand for wwater. This allows the system to react in real-time to the demand requirements using the minimum investment in hardware.

Several pumps are operated in parallel with a water supply system. One of the pumps is directly controlled by the Inverter. The remaining pumps, if required, are operated at a fixed-speed.

The system comprises of the following components:

- Control Unit
- Power Module

- Motor
- Geared motor
- Pumps
- Pressure sensor
- Flow-rate sensor
- Level sensor
- Temperature sensor (optional)

Safety commissioning

This wizard is designed to allow the user to commission the Inverters with safety-integrated functions. The user is guided through the necessary steps to commission the various safety-integrated functions available, depending upon the type of Control Unit to be used with the user application. The wizard will only display the functions that are available for their specific Control Unit; if no safety functions are available, the wizard will not be displayed in the wizard menu structure.

There are two levels of safety commissioning wizards and these are as follows:

- Basic Safety Commissioning - allows the configuration of the safety digital inputs and signals for the following safety functions:
 - Safe Torque Off (STO)
 - ProfiSafe
- Extended Safety Commissioning - allows the configuration of the safety digital inputs and signals for the following safety functions:
 - Safe Stop 1 (SS1)
 - Safe Stop 2 (SS2)
 - Safe Operating Stop (SOS)
 - Safe Low Speed (SLS)
 - Safe Torque Off (STO)
 - ProfiSafe

Each of these wizards can be used to configure inputs and signals for the user's specific application requirements.

4.1 Example wizard

Overview of wizards

The following example of how wizards work on the IOP are purely for demonstration purpose only. It should be understood that the screens, questions and steps for each wizard are dependent on the following influences:

- The firmware version of the IOP in use.
- The firmware version of the Control Unit to which the IOP is fitted.
- The type of Control Unit to which the IOP is fitted - not all Control Units have the same functionality and this will change the structure of the IOP menus including the type and number of wizards that will be offered to the user.

 CAUTION
--

Before commissioning an application
--

<p>Prior to using the a wizard, it is essential that the user's Control Unit and Power Module have been installed and wired correctly, in accordance with the requirements of the user's application. This is extremely important in the case of commissioning safety-integrated applications. All inputs and outputs must be defined and configured before any commissioning can take place, including the observation and adherence of all local, national and international safety regulations required for the user's application and all devices utilized by the user's application.</p>

4.1.1 Basic commissioning with IOP

Basic commissioning wizard

Note**Software limitations**

The Basic Commissioning wizard detailed below is for Control Units with version 4.3 software or earlier.

4.1 Example wizard

1. Select "Basic Commissioning..." from the Wizards menu.

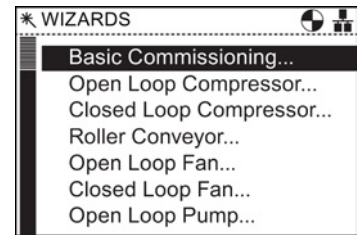

2. Select "Yes" or "No" to a factory reset.

The factory reset is performed prior to saving all the parameter changes that have been made during the basic commissioning process.

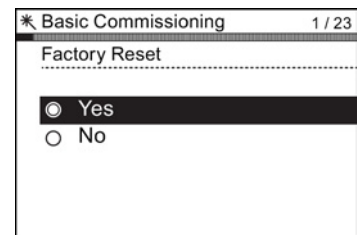

3. Select the Control Mode for the attached motor.

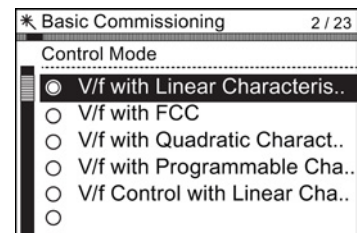

4. Select the correct Motor Data for your Inverter and attached motor.

This data is used to calculate the correct speed and displayed values for the application.

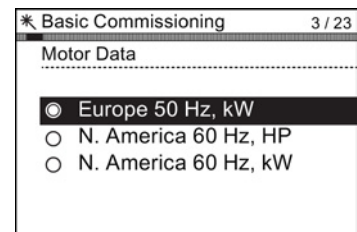

5. Select the correct frequency for your Inverter and attached motor.

The use of the 87 Hz characteristic allows the motor to operate at 1.73 times of its normal speed.

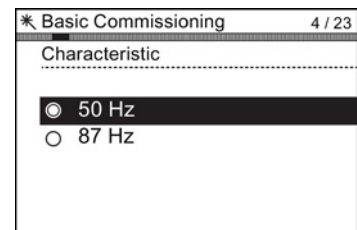

6. At this stage the wizard will begin to ask for the data relating specifically to the attached motor. The data is obtained from the motor rating plate.

* Basic Commissioning 5 / 23

Motor Connections

Please input motor data according to used motor connection

Continue

7. The Motor Data screen indicates the frequency characteristic of the attached motor.

* Basic Commissioning 6 / 23

Motor Data

Please input 50 Hz motor data

Continue

8. Input the correct Motor Voltage from the motor rating plate.

* Basic Commissioning 7 / 23

Motor Voltage

↑ 20000

00400 V

↓ 0

9. Input the correct Motor Current from the motor rating plate.

* Basic Commissioning 8 / 23

Motor Current

↑ 6.20

0.42 A

↓ 0.00

10. Input the correct Power Rating from the motor rating plate.

* Basic Commissioning 9 / 23

Power Rating

↑ 100000.00

0000000.12 kW

↓ 0.00

4.1 Example wizard

- 11. Input the correct Motor Speed from the motor rating plate.
This value is given in RPM.

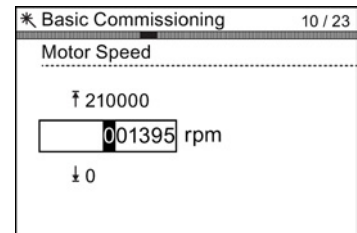

- 12. Select to run or disable Motor Data Identification function.
This function, if active, will not start until the first run command is given to the Inverter.

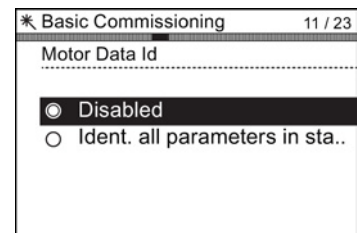

- 13. Select either zero pulse on no zero pulse for the attached encoder.
If no encoder is fitted to the motor, the option will not be displayed.

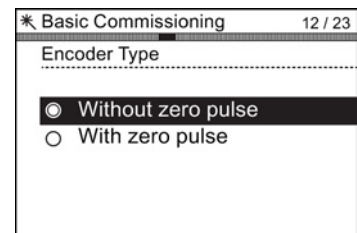

- 14. Enter the correct pulses per revolution for the encoder.
This information is normally printed on the casing of the encoder.

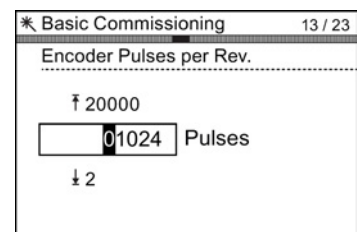

- 15. Select the command source for the controlling commands for the Inverter/motor system.

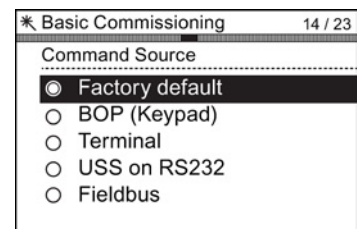

16. Select the Main Setpoint Source for the speed control of the Inverter/motor system.

* Basic Commissioning 15 / 23

Main Setpoint Source

No Main Setpoint

MOP Setpoint

Analogue Setpoint

Fixed Frequency

Fieldbus

17. Select the Additional Setpoint Source for the speed control of the Inverter/motor system.

* Basic Commissioning 16 / 23

Add. Setpoint Source

No Add. Setpoint

MOP Setpoint

Analogue Setpoint

Fixed Frequency

Fieldbus

18. Set the Minimum Speed at which the attached motor should run.

* Basic Commissioning 17 / 23

Minimum Speed

↑ 19500.00

rpm

↓ 0.00

19. Set the Ramp Up time in seconds.
This is the time the Inverter/motor system will take from being given the run command, to reaching the selected motor speed.

* Basic Commissioning 18 / 23

Ramp Up

↑ 999999.00

s

↓ 0.00

20. Set the Ramp Down time in seconds.
This is the time the Inverter/motor system will take from being given the OFF1 command, for the motor to reach a standstill.

* Basic Commissioning 19 / 23

Ramp Down

↑ 999999.00

s

↓ 0.00

4.1 Example wizard

- 21. A summary of all the settings is display.
If the settings are correct, select Continue.

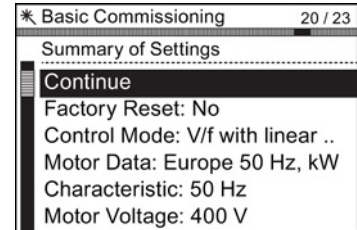

- 22. The final screen gives two options:
 - Save settings
 - Cancel Wizard
 If save is selected, a factory reset will be performed then the settings are saved to the Inverter memory. The location of safe data is assigned using the "Parameter saving mode" function in "Parameter settings" in "Menu".

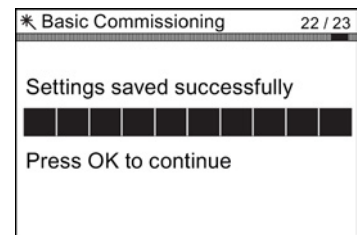

4.1.2 Basic commissioning with IOP and P0015 Macros

Basic commissioning wizard

The Basic Commissioning wizard detailed below is for Control Units with version 4.4 software or higher.

Procedure



For performing the basic commissioning of the converter with the IOP operator panel, proceed the following steps:

1. Select "Basic Commissioning..." from the Wizards menu.
2. Select "Yes" or "No" to a factory reset.

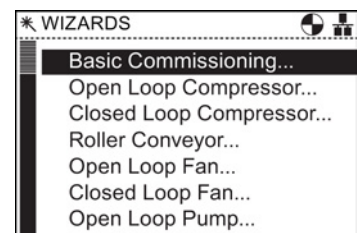

The factory reset is performed prior to saving all the parameter changes that have been made during the basic commissioning process.

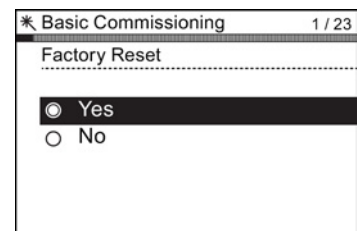

3. Select the Control Mode for the attached motor.
4. Select the correct Motor Data for your Inverter and attached motor.
This data is used to calculate the correct speed and displayed values for the application.
5. Select the correct frequency for your Inverter and attached motor.
The use of the 87 Hz characteristic allows the motor to operate at 1.73 times of its normal speed.
6. At this stage the wizard will begin to ask for the data relating specifically to the attached motor. The data is obtained from the motor rating plate.
7. The Motor Data screen indicates the frequency characteristic of the attached motor.
8. Input the correct Motor Voltage from the motor rating plate.

* Basic Commissioning 2 / 23

Control Mode

V/f with Linear Characteris..

V/f with FCC

V/f with Quadratic Charact..

V/f with Programmable Cha..

V/f Control with Linear Cha..

* Basic Commissioning 3 / 23

Motor Data

Europe 50 Hz, kW

N. America 60 Hz, HP

N. America 60 Hz, kW

* Basic Commissioning 4 / 23

Characteristic

50 Hz

87 Hz

* Basic Commissioning 5 / 23

Motor Connections

Please input motor data according to used motor connection

Continue

* Basic Commissioning 6 / 23

Motor Data

Please input 50 Hz motor data

Continue

* Basic Commissioning 7 / 23

Motor Voltage

↑ 20000

V

↓ 0

4.1 Example wizard

- 9. Input the correct Motor Current from the motor rating plate.

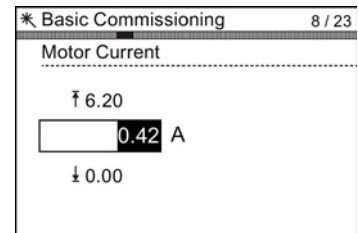

- 10. Input the correct Power Rating from the motor rating plate.

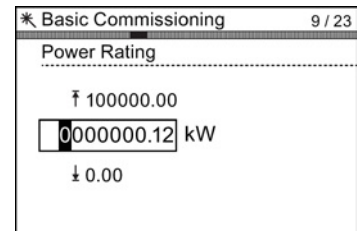

- 11. Input the correct Motor Speed from the motor rating plate.
This value is given in RPM.

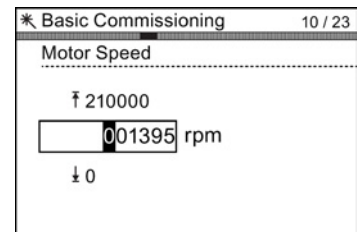

- 12. Select to run or disable Motor Data Identification function.
This function, if active, will not start until the first run command is given to the Inverter.

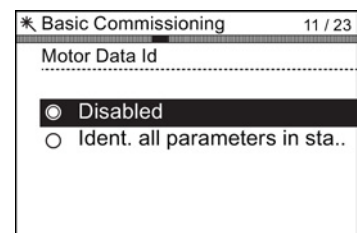

- 13. Select either zero pulse on no zero pulse for the attached encoder.
If no encoder is fitted to the motor, the option will not be displayed.

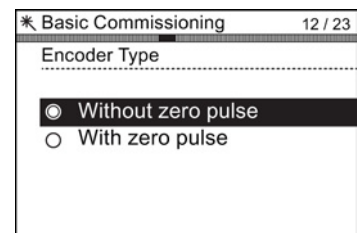

- 14. Enter the correct pulses per revolution for the encoder.
This information is normally printed on the casing of the encoder.

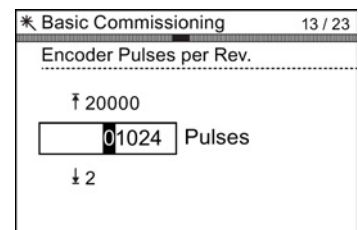

15. Select the macro that is suitable for your application. Once selected all inputs, outputs, command sources and setpoints will be automatically configured by the software.

For further information see the section that details the precise settings for each macro. Please see installation section of this manual.

16. Set the Minimum Speed at which the attached motor should run.

17. Set the Ramp Up time in seconds.

This is the time the Inverter/motor system will take from being given the run command, to reaching the selected motor speed.

18. Set the Ramp Down time in seconds.

This is the time the Inverter/motor system will take from being given the OFF1 command, for the motor to reach a standstill.

19. A summary of all the settings is display. If the settings are correct, select Continue.

20. The final screen gives two options:

- Save settings
- Cancel Wizard

If save is selected, a factory reset will be performed then the settings are saved to the Inverter memory. The location of safe data is assigned using the "Parameter saving mode" function in "Parameter settings" in "Menu".

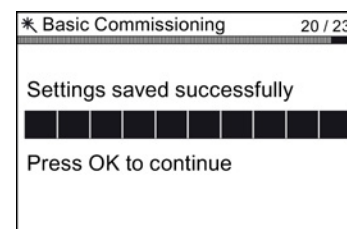
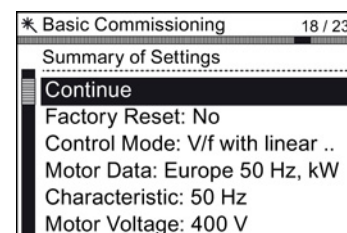
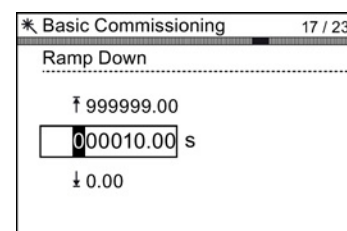
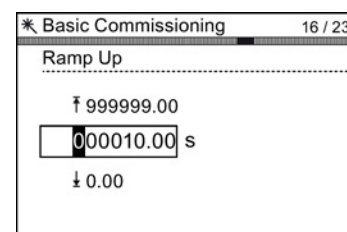
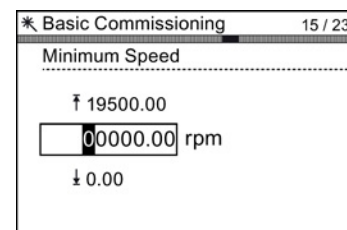
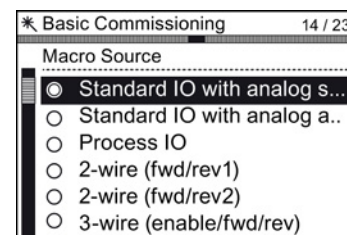

The basic commissioning of your converter is finished.

4.1.3 Pre-assignment of IOs and wiring for P0015 Macros

Examples of macro (P0015) IO pre-assignments

The following examples show the pre-assigned input and output that are setup automatically depending upon the macro that is selected during basic commissioning. The input and output assignments are specific for each individual type of Control Unit and therefore, the information given below is only as an example. It is important that the user refers to the Operating Instructions for their specific Control Unit where detailed information is given regarding the pre-assignment of inputs and outputs. It is possible to manually configure the inputs and outputs if a suitable macro cannot be found for the users application; detailed information on manually configuring the input and outputs is also given in the Operating Instructions for each specific Control Unit.

Fixed speeds

Macro 1 Two-wire control with two fixed speeds

p1003 = Fixed speed 3
p1004 = Fixed speed 4

DI 4 and DI 5 = HIGH:
Frequency converter added
fixed speed 3 + fixed speed 4

5	DI 0	ON/OFF1 right	Fault	18	DO 0
6	DI 1	ON/OFF1 left		19	
7	DI 2	Acknowledge		20	
8	DI 3	---	Alarm	21	DO 1
16	DI 4	Fixed speed 3		22	
17	DI 5	Fixed speed 4			
3	AI 0	---	Speed	12	AO 0
4			0 V ... 10 V	13	
10	AI 1	---	Current	26	AO 1
11			0 V ... 10 V	27	

Macro 2 Two fixed speeds with safety function

p1001 = Fixed speed 1
p1002 = Fixed speed 2

DI 0 and DI 1 = HIGH:
Motor rotates with
fixed speed 1 + fixed speed 2

5	DI 0	ON/OFF1 + fixed speed 1	Fault	18	DO 0
6	DI 1	Fixed speed 2		19	
7	DI 2	Acknowledge		20	
8	DI 3	---	Alarm	21	DO 1
16	DI 4	Reserved for safety function		22	
17	DI 5				
3	AI 0	---	Speed	12	AO 0
4			0 V ... 10 V	13	
10	AI 1	---	Current	26	AO 1
11			0 V ... 10 V	27	

Macro 3 Four fixed speeds

p1001 = Fixed speed 1
p1002 = Fixed speed 2
p1003 = Fixed speed 3
p1004 = Fixed speed 4

Several DI = HIGH:
Frequency converter adds corresponding fixed
speeds

5	DI 0	ON/OFF1 + fixed speed 1	Fault	18	DO 0
6	DI 1	Fixed speed 2		19	
7	DI 2	Acknowledge		20	
8	DI 3	---	Alarm	21	DO 1
16	DI 4	Fixed speed 3		22	
17	DI 5	Fixed speed 4			
3	AI 0	---	Speed	12	AO 0
4			0 V ... 10 V	13	
10	AI 1	---	Current	26	AO 1
11			0 V ... 10 V	27	

Macro 4 PROFIBUS DP or PROFINET fieldbus

5	DI 0	---	Fault	18	DO 0
6	DI 1	---		19	
7	DI 2	Acknowledge		20	
8	DI 3	---	Alarm	21	DO 1
16	DI 4	---		22	
17	DI 5	---			
3	AI 0	---	Speed	12	AO 0
4			0 V ... 10 V	13	
10	AI 1	---	Current	26	AO 1
11			0 V ... 10 V	27	

PROFIBUS DP
PROFINET
Telegram 352

4.1 Example wizard

Macro 5 **Fieldbus with safety function or PROFINET**

5	DI 0	---		Fault	18	DO 0
6	DI 1	---			19	
7	DI 2	Acknowledge			20	
8	DI 3	---		Alarm	21	DO 1
16	DI 4	Reserved for safety function			22	
17	DI 5					
3	AI 0	---		Speed	12	AO 0
4				0 V ... 10 V	13	
10	AI 1	---		Current	26	AO 1
11				0 V ... 10 V	27	

PROFIBUS DP
PROFINET
Telegram 352

Two safety functions

This default setting is only possible for the CU240E-2 F, CU240E-2 DP-F and CU240E-2 PN-F Control Units.

Macro 6 **PROFIBUS DP or PROFINET fieldbus with two safety functions**

5	DI 0	Reserved for safety function 1		Fault	18	DO 0
6	DI 1					19
7	DI 2	---			20	
8	DI 3	Acknowledge		Alarm	21	DO 1
16	DI 4	Reserved for safety function 2			22	
17	DI 5					
3	AI 0	---		Speed	12	AO 0
4				0 V ... 10 V	13	
10	AI 1	---		Current	26	AO 1
11				0 V ... 10 V	27	

PROFIBUS DP
PROFINET
Telegram 1

Automatic/local - Changeover between fieldbus and jog mode

Factory setting for converters with PROFIBUS or PROFINET interface:

Macro 7 **DI 3 = LOW Fieldbus PROFIBUS DP or PROFINET**

5	DI 0	---		Fault	18	DO 0
6	DI 1	---			19	
7	DI 2	Acknowledge			20	
8	DI 3	LOW		Warning	21	DO 1
16	DI 4	---			22	
17	DI 5	---				
3	AI 0	---		Speed	12	AO 0
4				0 V ... 10 V	13	
10	AI 1	---		Current	26	AO 1
11				0 V ... 10 V	27	

PROFIBUS DP
PROFINET
Telegramm 1

DI 3 = HIGH Jogging via DI 0 and DI 1

5	DI 0	Jog 1		Fault	18	DO 0
6	DI 1	Jog 2			19	
7	DI 2	Acknowledge			20	
8	DI 3	HIGH		Warning	21	DO 1
16	DI 4	---			22	
17	DI 5	---				
3	AI 0	---		Speed	12	AO 0
4				0 V ... 10 V	13	
10	AI 1	---		Current	26	AO 1
11				0 V ... 10 V	27	

p1058 = Jog 1
p1059 = Jog 2

Motorized potentiometer

Macro 8 Motorized potentiometer (MOP) with safety function

5	DI 0	ON/OFF1	Fault	18	DO 0
6	DI 1	MOP up		19	
7	DI 2	MOP down		20	
8	DI 3	Acknowledge	Alarm	21	DO 1
16	DI 4	Reserved for safety function		22	
17	DI 5				
3	AI 0	---	Speed	12	AO 0
4			0 V ... 10 V	13	
10	AI 1	---	Current	26	AO 1
11			0 V ... 10 V	27	

Macro 9 Motorized potentiometer (MOP)

5	DI 0	ON/OFF1	Fault	18	DO 0
6	DI 1	MOP up		19	
7	DI 2	MOP down		20	
8	DI 3	Acknowledge	Alarm	21	DO 1
16	DI 4	---		22	
17	DI 5	---			
3	AI 0	---	Speed	12	AO 0
4			0 V ... 10 V	13	
10	AI 1	---	Current	26	AO 1
11			0 V ... 10 V	27	

Applications with analog setpoint

Macro 13 Setpoint via analog input and safety function

5	DI 0	ON/OFF1	Fault	18	DO 0
6	DI 1	Reversing		19	
7	DI 2	Acknowledge		20	
8	DI 3	---	Alarm	21	DO 1
16	DI 4	Reserved for safety function		22	
17	DI 5				
3	AI 0	Setpoint	Speed	12	AO 0
4		I□■U -10 V ... 10 V	0 V ... 10 V	13	
10	AI 1	---	Current	26	AO 1
11			0 V ... 10 V	27	

Process industry

Macro 14 DI 3 = LOW PROFIBUS DP or PROFINET fieldbus

5	DI 0	---	Fault	18	DO 0
6	DI 1	External fault		19	
7	DI 2	Acknowledge		20	
8	DI 3	LOW	Alarm	21	DO 1
16	DI 4	---		22	
17	DI 5	---			
3	AI 0	---	Speed	12	AO 0
4			0 V ... 10 V	13	
10	AI 1	---	Current	26	AO 1
11			0 V ... 10 V	27	

PROFIBUS DP
PROFINET
Telegram 20

DI 3 = HIGH Motorized potentiometer (MOP)

5	DI 0	ON/OFF1	Fault	18	DO 0
6	DI 1	External fault		19	
7	DI 2	Acknowledge		20	
8	DI 3	HIGH	Alarm	21	DO 1
16	DI 4	MOP up		22	
17	DI 5	MOP down			
3	AI 0	---	Speed	12	AO 0
4			0 V ... 10 V	13	
10	AI 1	---	Current	26	AO 1
11			0 V ... 10 V	27	

4.1 Example wizard

Macro 15				DI 3 = LOW				Analog setpoint			
5	DI 0	ON/OFF1	Fault	18	DO 0						
6	DI 1	External fault		19							
7	DI 2	Acknowledge		20							
8	DI 3	LOW	Alarm	21	DO 1						
16	DI 4	---		22							
17	DI 5	---									
3	AI 0	Setpoint	Speed	12	AO 0						
4		I <input type="checkbox"/> U -10 V ... 10 V	0 V ... 10 V	13							
10	AI 1	---	Current	26	AO 1						
11			0 V ... 10 V	27							

DI 3 = HIGH				Motorized potentiometer (MOP)			
5	DI 0	ON/OFF1	Fault	18	DO 0		
6	DI 1	External fault		19			
7	DI 2	Acknowledge		20			
8	DI 3	HIGH	Alarm	21	DO 1		
16	DI 4	MOP up		22			
17	DI 5	MOP down					
3	AI 0	---	Speed	12	AO 0		
4			0 V ... 10 V	13			
10	AI 1	---	Current	26	AO 1		
11			0 V ... 10 V	27			

Two- or three-wire control

Macro 12 is the factory setting for converters with the Control Units CU240E-2 and CU240E-2 F.

	Macro 12	Macro 17	Macro 18
Two-wire control	Method 1	Method 2	Method 3
Control command 1	ON/OFF1	ON/OFF1 right	ON/OFF1 right
Control command 2	Reversing	ON/OFF1 left	ON/OFF1 left

5	DI 0	Control command 1	Fault	18	DO 0		
6	DI 1	Control command 2		19			
7	DI 2	Acknowledge		20			
8	DI 3	---	Alarm	21	DO 1		
16	DI 4	---		22			
17	DI 5	---					
3	AI 0	Setpoint	Speed	12	AO 0		
4		I <input type="checkbox"/> U -10 V ... 10 V	0 V ... 10 V	13			
10	AI 1	---	Current	26	AO 1		
11			0 V ... 10 V	27			

	Macro 19	Macro 20
Three-wire control	Method 1	Method 2
Control command 1	Enable/OFF1	Enable/OFF1
Control command 2	ON right	ON
Control command 3	ON left	Reversing

5	DI 0	Control command 1	Fault	18	DO 0		
6	DI 1	Control command 2		19			
7	DI 2	Control command 3		20			
8	DI 3	Acknowledge	Alarm	21	DO 1		
16	DI 4	---		22			
17	DI 5	---					
3	AI 0	Setpoint	Speed	12	AO 0		
4		I <input type="checkbox"/> U -10 V ... 10 V	0 V ... 10 V	13			
10	AI 1	---	Current	26	AO 1		
11			0 V ... 10 V	27			

Communication with a higher-level control via USS

Macro 21	Fieldbus USS
	p2020 = Baud rate
	p2022 = PZD number
	p2023 = PKW number

5	DI 0	---	Fault	18	DO 0		
6	DI 1	---		19			
7	DI 2	Acknowledge		20			
8	DI 3	---	Alarm	21	DO 1		
16	DI 4	---		22			
17	DI 5	---					
3	AI 0	---	Speed	12	AO 0		
4			0 V ... 10 V	13			
10	AI 1	---	Current	26	AO 1		
11			0 V ... 10 V	27			

USS
 38400 Baud
 2 PZD, PIV variable

4.1.4 Wiring diagrams

Overview

Since the purpose of the IOP Wizards are to guide the user through the setting-up and commissioning of applications, some assumptions must be made as to the technical knowledge, qualifications and practical knowledge of the potential user.

The user must be a qualified and experienced drives engineer - this is required because they must have a complete understanding of the application that is to be commissioned.

The user must be fully conversant with all the technologies and protocols of the following:

- PLCs - Set-up, programming and communications
- Inverters - Set-up, wiring and commissioning
- All relevant international, local safety regulations

The information provided will be the information required to wiring the application with regards to the Inverter inputs, outputs and communications connections.

Prerequisite actions

The user must ensure that all the following actions are completed prior to using the IOP wizards:

- All necessary equipment is available and installed correctly, according to the relevant wiring diagram for the specific application wizard.
- All wiring of the Inverter, motor and other devices used within the application is complete in accordance to the enclosed wiring diagrams.
- All necessary information, such as the rating label information of the motor, is available.
- All components of the system have been tested to ensure their correct and safe installation.

IOP Wizard Information

The IOP will present to the user a menu system, by which they can select the appropriate Wizard for the application. The user will then be presented with a list of questions specific to the application. The user can use the wiring diagrams to answer the questions, concerning connections, input and outputs and their associated functions.

A complete wiring diagram is given in this section for each application.

4.1 Example wizard

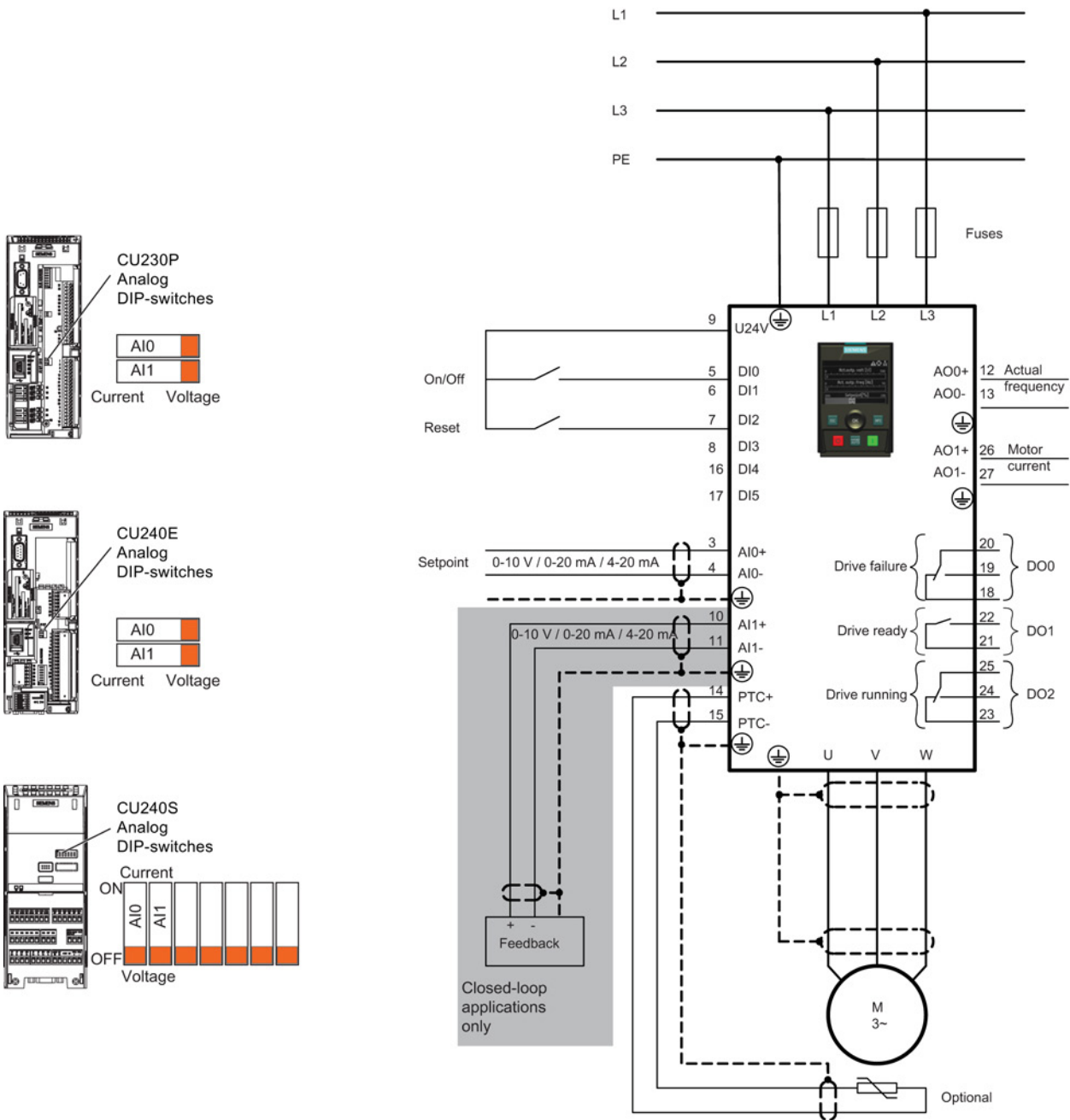

Figure 4-3 Compressor wiring diagram CU240S CU230P-2 CU240E-2

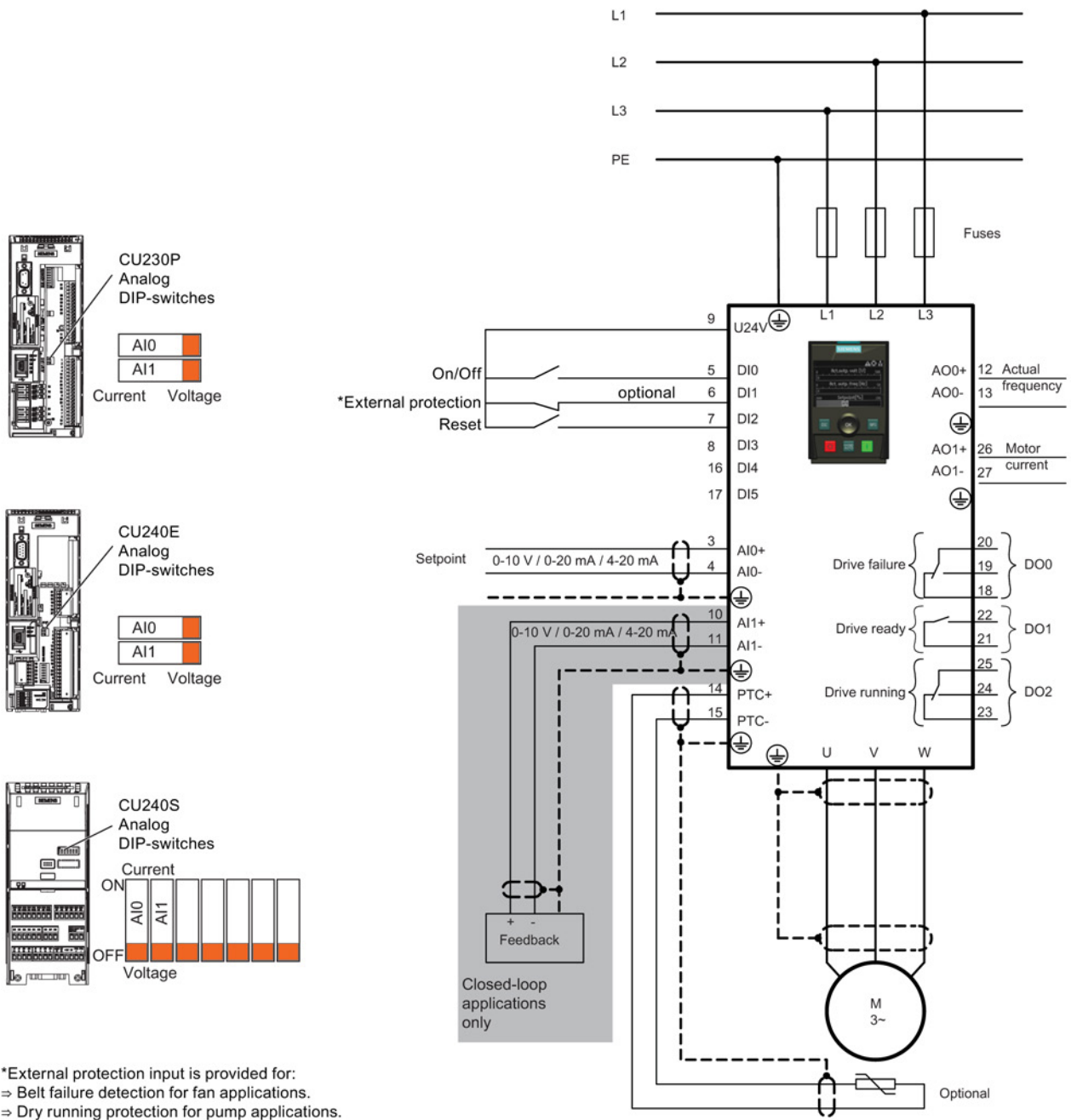
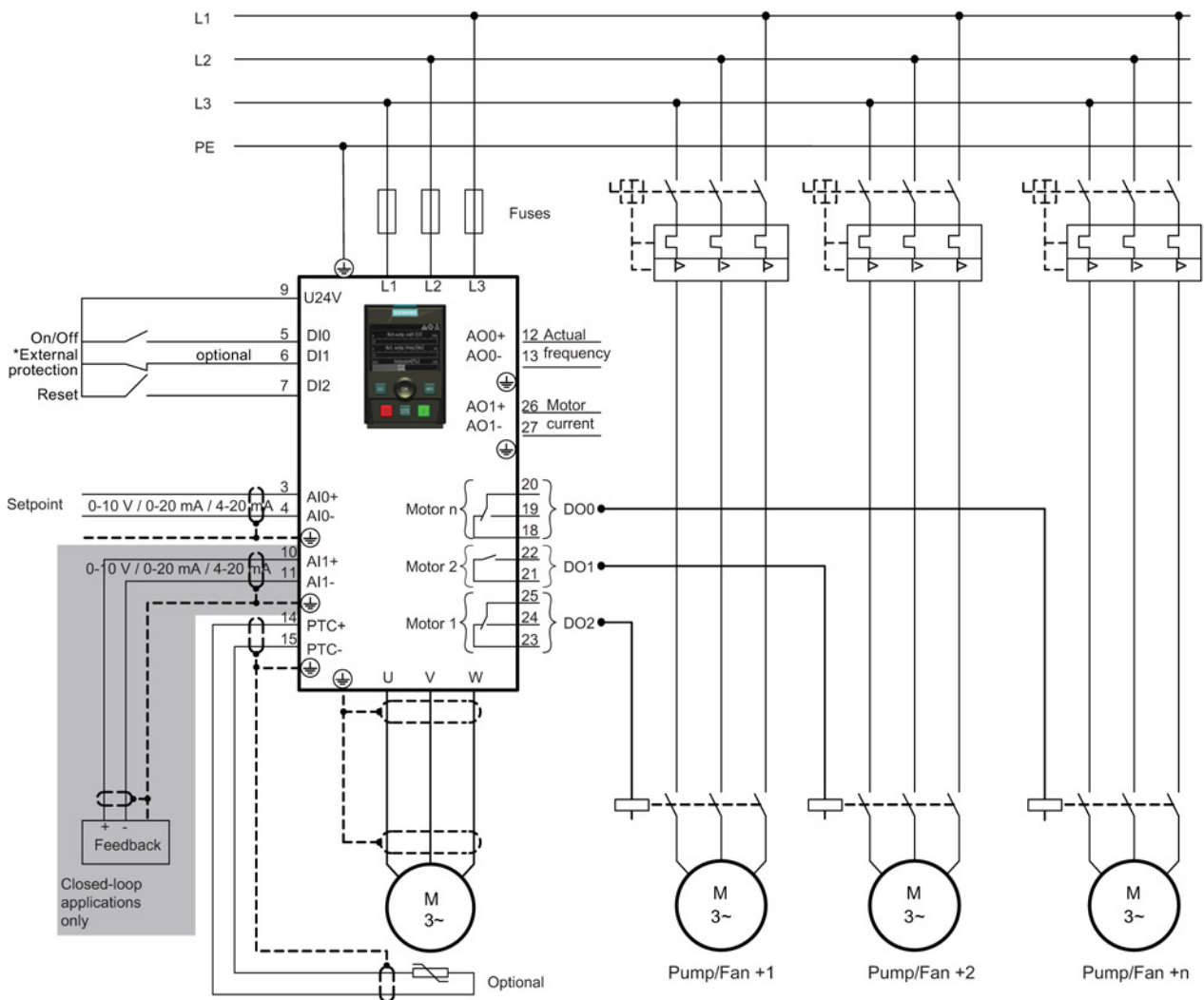

Figure 4-4 Pump and fan wiring diagram CU240S CU230P-2 CU240E-2

4.1 Example wizard



*External protection input is provided for:
 ⇒ Belt failure detection for fan applications.
 ⇒ Dry running protection for pump applications.

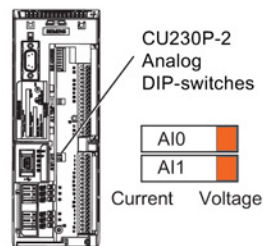

Figure 4-5 Pump and fan staging wiring diagram CU230P-2

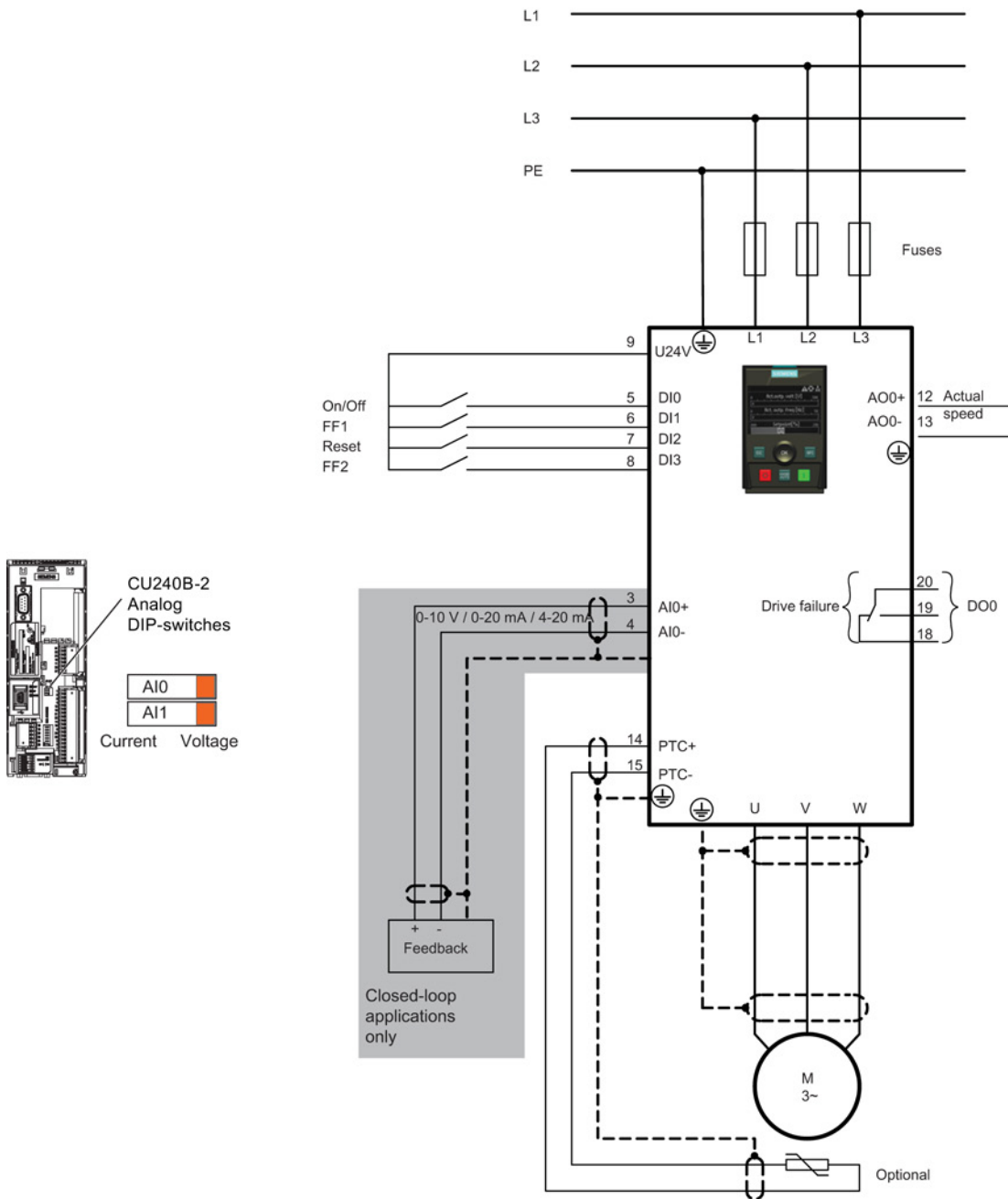

Figure 4-6 Compressor, pump and fan wiring diagram CU240B-2 and G120C

Wiring diagrams for conveyor applications

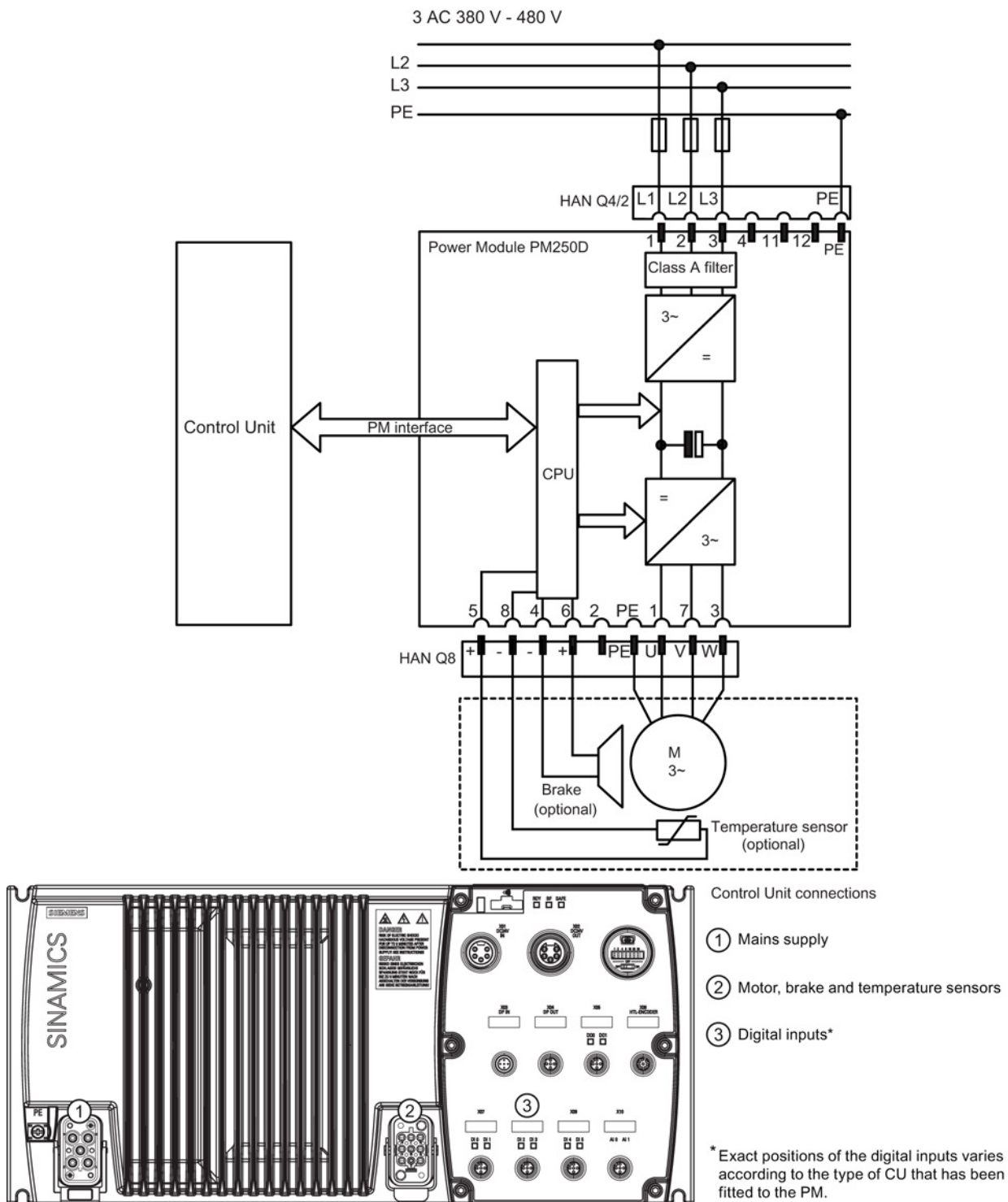

Figure 4-7 Conveyor application wiring diagram

Configuration Information for conveyor wizard

This information allows the user to configure the Inverter for the following applications:

- Roller conveyor with 2 speeds and 2 directions
- Roller conveyor with 2 speeds and 1 direction
- A turntable

Digital connections

The digital inputs are assigned as follows for each application:

Table 4- 1 Roller conveyor (2 directions/2 speeds) and turntable conveyor inputs

Digital input	Function	Device	Abbreviation
DI0	Roller conveyor position F	Sensor	-F
DI2	Roller conveyor position B	Sensor	-B
DI4	Changeover, fast/slow after F	Sensor	-F/S-F
DI5	Changeover, fast/slow after B	Sensor	-F/S-B

Table 4- 2 Roller conveyor (1 direction/2 speeds) inputs

Digital input	Function	Device	Abbreviation
DI0	Roller conveyor position F	Sensor	-F
DI2	Roller conveyor position B	Sensor	-B
DI4	Changeover, fast/slow after F	Sensor	-F/S-F

4.1 Example wizard

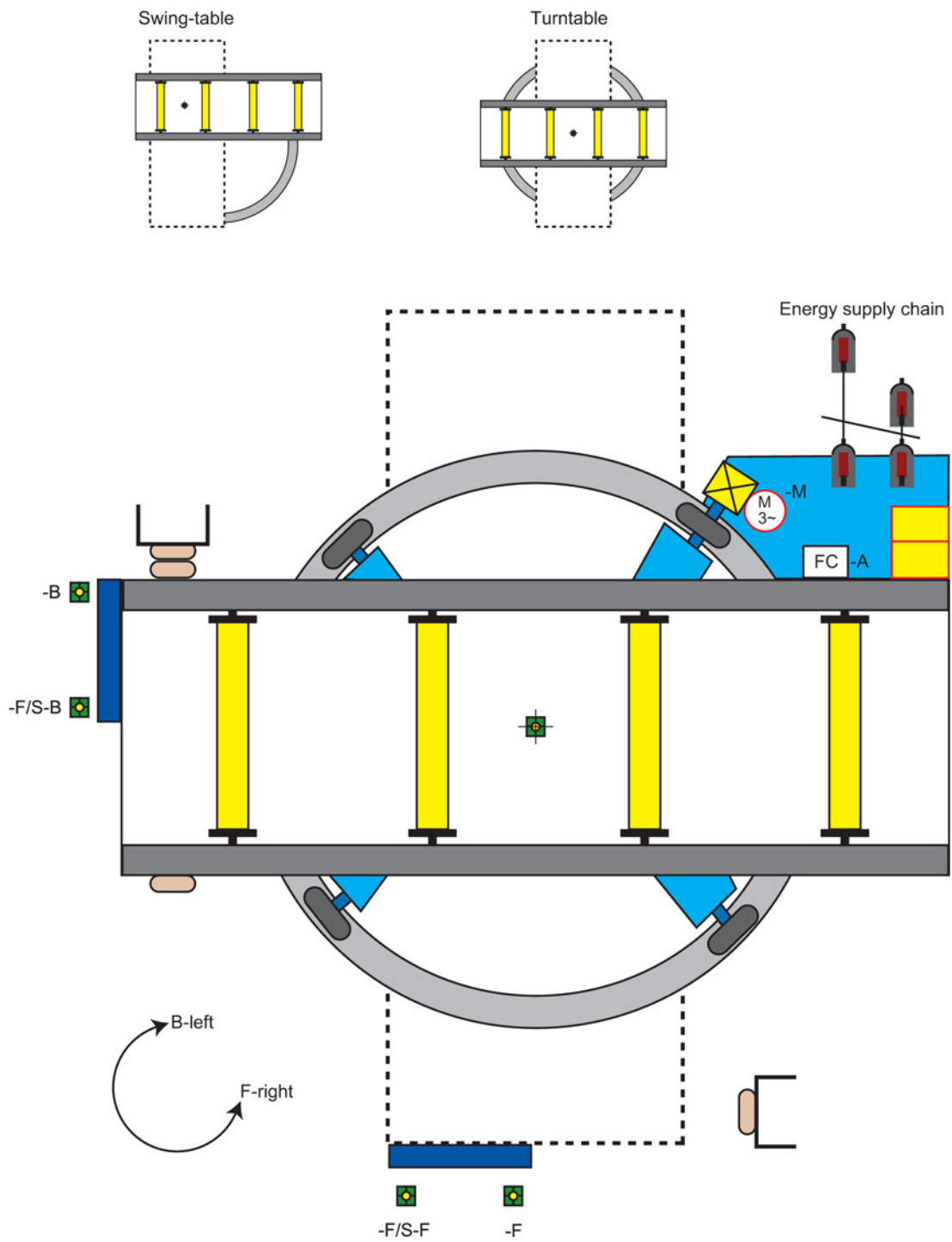

Figure 4-8 Rotary conveyor schematic

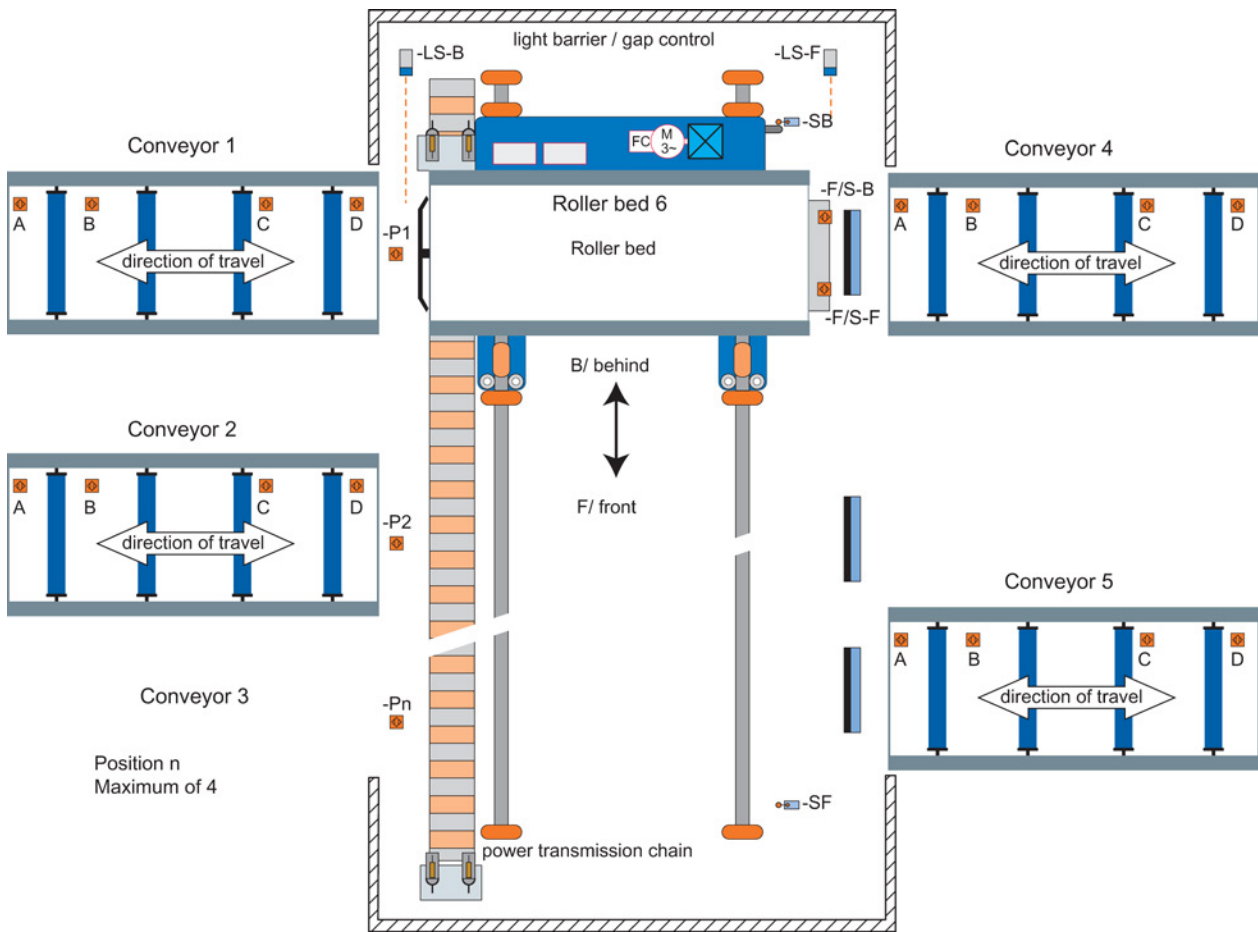

Figure 4-9 Roller conveyor schematic

Control

Overview

The Control menu allows the user to change the following settings in real-time:

- Setpoint
- Reverse
- Jog

The control menu is accessed from the menu at the bottom-centre of the Status screen, as shown below.

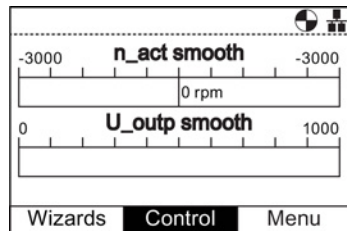

Figure 5-1 Status screen with the Control Menu highlighted

Setpoint

The setpoint value determines the speed at which the motor runs as a percentage of its full range of motion.

To change the setpoint, the following actions should be performed:

1. Rotate the **Wheel** to select "**Control**".
2. Press the **Wheel** to confirm selection.
3. The "**Control**" screen is displayed.
4. "**Setpoint**" is already highlighted.
5. Press the **Wheel** to select the "**Setpoint**".
6. The "**Setpoint**" screen is displayed.
7. Rotate the **Wheel** to increase or decrease the setpoint.
8. Press the **Wheel** to confirm new setpoint. If the "**Esc**" is given a single or a long press the setpoint is also saved.
9. The "**Control**" screen is displayed.
10. Press "**Esc**" to return to the "**Status**" screen.

The setpoint can only be modified from the IOP when the IOP is in Hand mode. Changing from HAND back to AUTO will reset the setpoint.

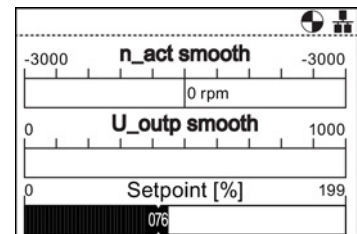
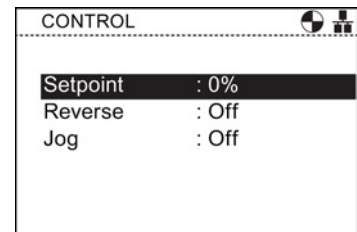

Reverse



The function of the reverse command is to set the direction of rotation of the motor from its normal forward motion.

To reverse the direction of the motor, the following actions should be performed:

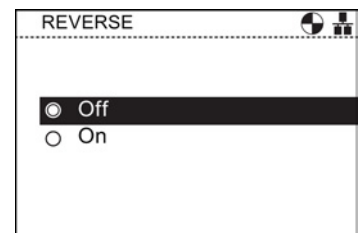
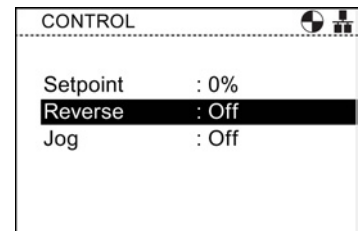
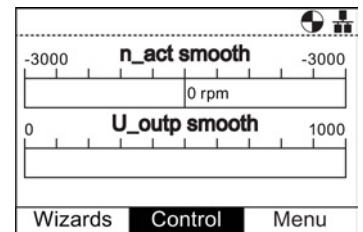
1. Rotate the **Wheel** to select "**Control**".
2. Press the **Wheel** to confirm selection.
3. The "**Control**" screen is displayed.
4. Rotate the **Wheel** to select the "**Reverse**" option.
5. Press the **Wheel** to confirm selection.
6. The "**Reverse**" screen is displayed.
7. Rotate the **Wheel** to select "**On**" or "**Off**".
8. Press the **Wheel** to confirm the selection.
9. The display returns to the "**Control**" screen.
10. Press "**Esc**" to return to the "**Status**" screen.



Jog

The Jog function, when selected will allow the motor to be manually rotated by a pre-determined value with each press of . If  is pressed continuously, the motor will rotate continuously until  is released.

To enable or disable the Jog function, the following actions should be performed:

1. Rotate the **Wheel** to select "**Control**".
2. Press the **Wheel** to confirm selection.
3. The "**Control**" screen is displayed.
4. Rotate the **Wheel** to select the "**Jog**" option.
5. Press the **Wheel** to confirm selection.
6. The "**Jog**" screen is displayed.
7. Rotate the **Wheel** to select "**On**" or "**Off**".
8. Press the **Wheel** to confirm selection.
9. The display returns to the "**Control**" screen
10. Press "**Esc**" to return to the "**Status**" screen.

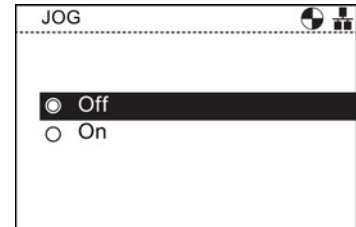
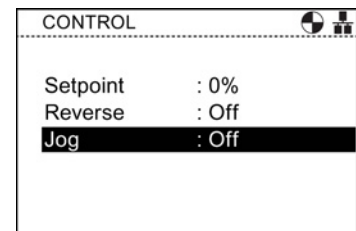
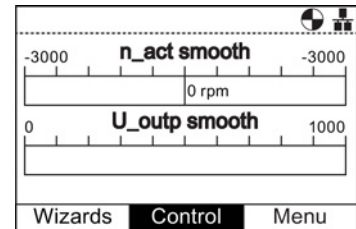

Note

Selection of Jog frequencies

It is important that the Jog parameters P1058 (Jog right) and P1059 (Jog left) are set to the required frequencies for the users application. The default jogging setpoint for both parameters is 5 Hz (150 rpm).

When the Jog left and Jog right (Jog1 and Jog 2) have been set; it is necessary to do a long press of the "INFO" key to select the other jog mode.

Menu

6.1 Overview

Overview

The "Menu" is selected from the three menu options at the bottom of the IOP screen. If the menu options are not displayed, then one press of the Wheel will display the menu options.

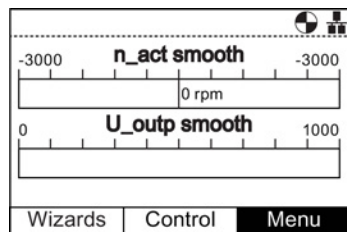

Menu selection

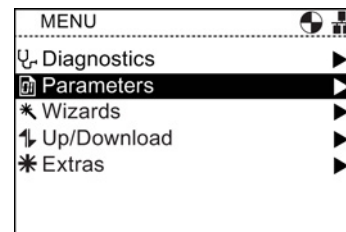

Menu screen

When the "Menu" option is selected the following functions are displayed:

- Diagnostics
- Parameters
- Wizards (this is a shortcut to the main Wizards menu)
- Up/Download
- Extras

By rotating the Wheel the required function can be highlighted. Pushing the Wheel confirms the selection and further sub-menus will be displayed. Pressing "**Esc**" once, will return the IOP to the previous screen, a longer press will return the display to the "Status" screen.

Note

IOP functional support

- Drives with SINAMICS firmware prior to version 4.2 may not be fully supported by the IOP.
 - The actual menu structure and functionality of the IOP will be influenced by the following factors:
 - The software version and type of Control Unit to which the IOP is fitted.
 - The firmware and software version of the IOP.
 - The selected functional group filtering of the parameters.
-

6.2 Diagnostics

Diagnostics menu

When the diagnostic function is selected the following options are presented:

- Active faults/alarms
- History
- Identification/Maintenance
- I/O status
- Communications status
- I/O simulation
- Drive enables

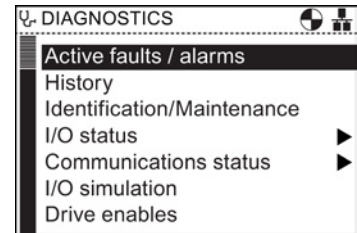

Active faults/alarms

When this option is selected the screen will display any active faults and alarms that have not yet been acknowledged.

Each fault and alarm can be selected and by pressing the **INFO** key or the **OK** key, an explanation of the fault or alarm will be displayed.

Pressing **INFO** or **OK** or **Esc** will return the display to the previous list of faults and alarms.

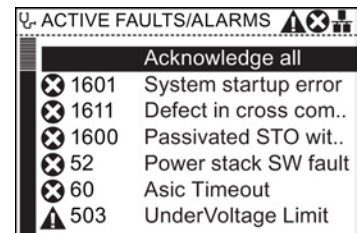

History

When this option is selected the screen will display a list of all previous faults and alarms with the time that they occurred.

Each fault and alarm can be selected and by pressing the **INFO** key or the **OK** key, an explanation of the fault or alarm will be displayed.

Pressing **INFO** or **OK** or **Esc** will return the display to the previous list of faults and alarms.

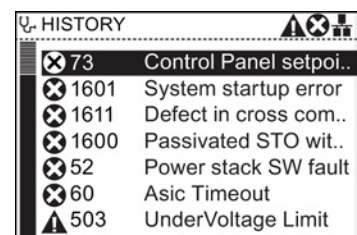

Identification/Maintenance

Displays specific technical information regarding the Control Unit and Power Module to which the IOP is attached will be displayed. The actual information displayed depends on the type of Control Unit and Power Module to which the IOP is connected.



I/O status

This option displays a list of the digital and analog inputs and outputs of the Inverter and their current status.

This is an information screen and cannot be changed.

Pressing **Esc** will return the display to the previous menu.

In the example shown opposite, the status of the digital inputs are displayed.

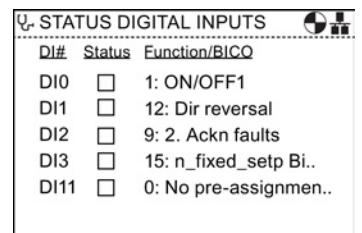
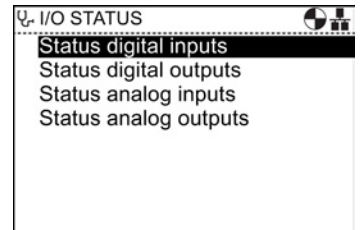

Communications status

The option displays the status of the fieldbus interface and the details of the settings for the data exchange, for example status words and control word lengths.

In the example shown opposite, the status of the fieldbus communications is shown.

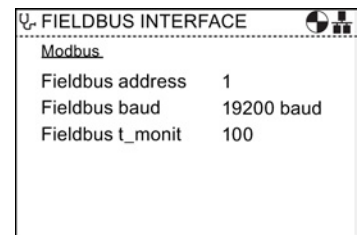
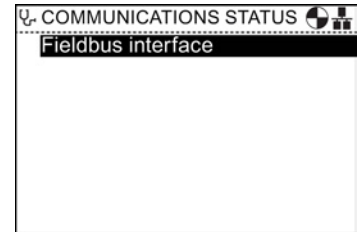

I/O simulation

 **WARNING**

Loss of control of the Inverter

If the Inverter is started using the I/O simulation and the IOP is removed from the Inverter it will not be possible to stop the Inverter running the motor. If the I/O simulation is activated, then only the I/O simulation can be used to stop the Inverter.

The IOP simulation screen allows digital and analog I/Os to be simulated without the requirement for external signals. These features are of great benefit during commissioning and fault finding, as the user can quickly simulate a situation without using wires, tools and external equipment.

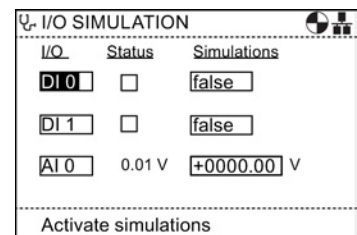

For example:

- A digital input can be made high without any wires in the terminals.
- An analog input or output can be driven to any value without any wires in the terminals.
- A digital output can be overridden and made high.

The screen presents the following options:

- I/O - Three I/Os can be simulated - two digital and one analog.
- Status - this indicates the real-time status of the input or output. If the square is shaded then the input or output signal is present. This is a read-only section of the screen.
- Control - this column of the screen displays the present status of the input or output and can be altered.

To use the I/O simulation the following actions should be performed:

1. Using the **wheel**, rotate the wheel until the required digital input or output is displayed in the first field.
2. Press **OK**.
3. The relevant control field is highlighted.
4. Using the **wheel**, rotate the wheel until the required control signal is displayed.
5. Press **OK**.
6. Repeat this process until all the fields have been completed as required.
7. When all fields have been completed the "activate the simulation" will be highlighted.
8. Press **OK**. The simulation will start running.
9. While the simulation is running "**Deactivate simulation**" will be highlighted - Press **OK** to stop the simulation.

Drive enables

The drive enables screen displays a list of all the current enabling signals for the Inverter. If the enable signal is present and active it will be selected . If the enable signal is not present and is not active it will be unselected .

This screen is read-only and is for information purposes only.

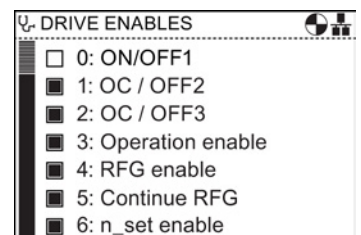

6.3 Parameters

Parameter menu

Note

IOP functional support

- Devices prior to version 4.2 firmware may not be fully supported by the IOP.
 - The actual menu structure and functionality of the IOP will be influenced by the following factors:
 - The software version and type of Control Unit to which the IOP is fitted.
 - The firmware and software version of the IOP.
 - The selected functional group filtering of the parameters.
 - When editing parameter or search values there is a choice to edit individual digits or an entire value. With a long press of the **Wheel** (>3 sec) it will toggle between the two different value editing modes.
-

The parameter menu allows the user extensive functionality and access to all the Inverter parameters. When this option is selected the user is given the opportunity to perform parameter orientated functions grouped in the following manner:

- Parameter groups
- Search by number
- My parameters
- Changed parameters

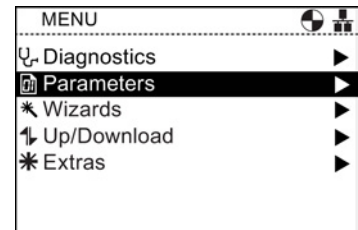

Note

SINAMICS S Drive Objects

The SINAMICS S range of Inverters deal with each component of the Inverter system as unique and separate entities, these unique entities are called "drive objects" (DO). When selecting "Parameters" from the Menu, there is an additional screen that requires the selection of the relevant DO before any parameters can be accessed. The default drive object is always Servo (DO2). If you wish to access the parameter relating to the Control Unit, the select "Control Unit (DO1)". See screenshot below.

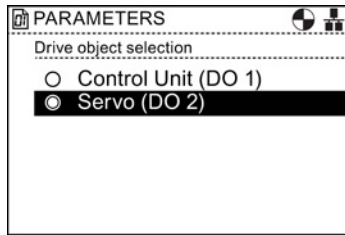
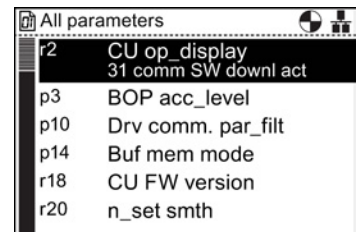

Figure 6-1 Parameters - Drive Object Selection

Parameter groups

All parameters

This options allows the user access to the individual parameters of the Inverter. The default filter is "Standard" which allows the user access to the most frequently used parameters. The default filter settings can be changed by selecting "Parameter filter" from the "Parameter settings" option in the "Extras Menu".



Quick commissioning

This screen displays a complete listing of all the parameters required for quick commissioning. The parameters are listed in numerical order and can be accessed to either confirm the set values or modified should there be a need to fine tune the application or correct any errors in the parameter values.

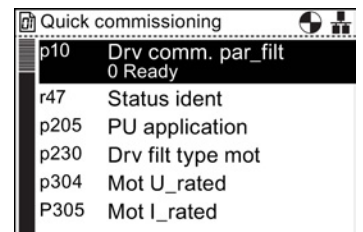

Saving & reset

This option allows the user access to all the parameters regarding the saving and reset functions of the Inverter. Each parameter displays its currently set value and these can be modified if required.

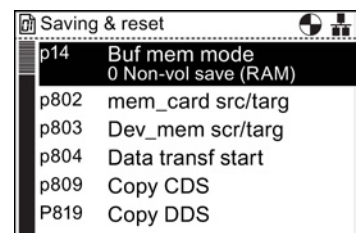

System Information

This screen displays all the parameters that contain system information regarding the Inverter. The majority of these parameters are read-only and are for information purposes only.

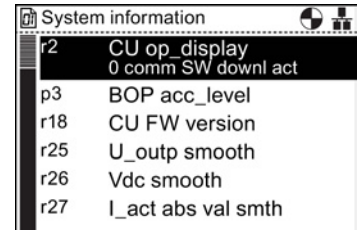

Inputs/Outputs

This option allows access to all the necessary parameters to configure the following signals:

- Digital inputs
- Digital outputs
- Analog inputs
- Analog outputs

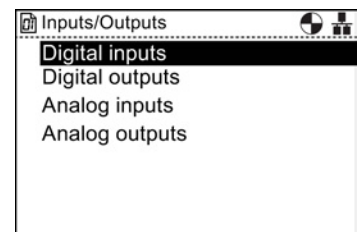

The user can navigate through the various inputs and outputs to see the current configuration of the inputs and outputs and, if necessary access the parameters directly to modify their values. In the example screen opposite, the parameters for the digital inputs is shown.

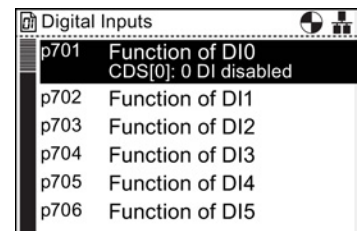

Setpoint channels

This option allows the user to display and modify the following setpoint parameters:

- Frequency setpoint
- Fixed setpoints
- Motor potentiometer
- Torque setpoint
- Jog setpoint
- Frequency limitation
- Ramp-function generator

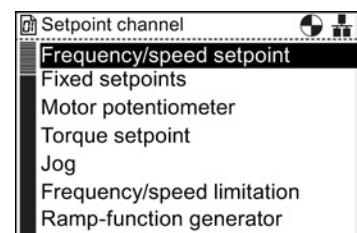

Motor control

This option allows the user to view, and if required, change the method by which the Inverter controls the attached motor. It presents the following control functions:

- V/f control
- Sensorless Vector control

The Inverter will not allow the control mode to be changed while the motor is running. The motor and therefore the system, must be stopped to allow the control mode to be changed.

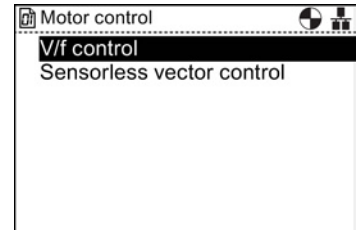
*Motor & periphery*

This option allows the following motor functions and options to be viewed, configured and modified:

- Motor data
- Motor temperature
- Motor encoder
- Motor holding brake

It is important that if any parameters concerning the above mentioned functions are to be modified, that the Inverter/motor system is in a safe state prior to the parameter changes. This is essential if any changes are being made to the Motor holding brake - all loads that may be affected by the change must be secured to avoid potentially dangerous situations.

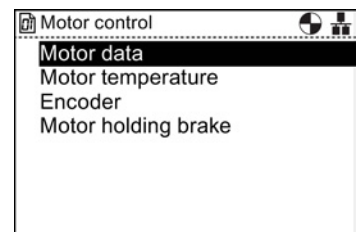
*Drive functions*

This option allows the user direct access to the parameters regarding the following drive functions:

- Shutdown functions
- Brake control
- Vdc controller
- Automatic restart
- Flying restart
- Safety Integrated

It is important that if any parameters concerning the above mentioned functions are to be modified, that the Inverter/motor system is in a safe state prior to the parameter changes.

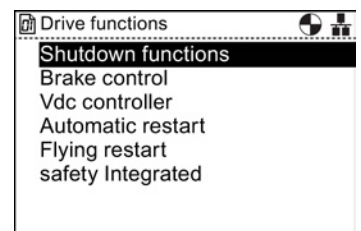

Application functions

This option allows the user direct access to specific application functions parameters as listed below:

- Technology controller
- Hibernation
- Load torque monitoring
- Digital time switch
- Positioning deceleration ramp
- Wobble function
- Free blocks

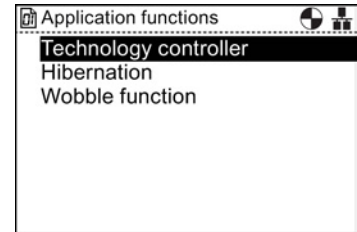

Fieldbus

This option allows the user direct access to the parameters that control and configure the fieldbus communications of the Inverter. The parameters can be viewed to confirm their settings and values, they can also be modified if they are not read-only parameters.

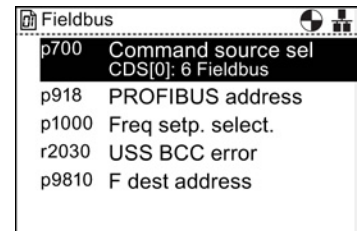

Diagnostics

This option allows the user direct access to the parameters that monitor the state of the system. They are divided into the following functional groups:

- Control/status words
- Interconnections
- Faults/alarms

All the parameters under these groupings are read-only and cannot be modified.

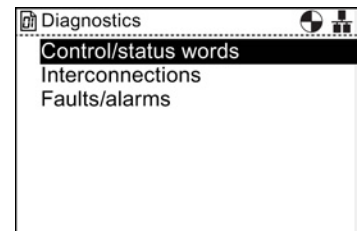

Search by number

This option allows the user to search for a specific parameter number. Should the parameter number not exist, then the nearest parameter to the entered value is displayed.

Use the **Wheel** to alter the value of each digit and press the **Wheel** to confirm. The next digit will automatically be highlighted, rotate the **Wheel** to change the value and press the **Wheel** to confirm. Once all fields have been entered, the IOP will display the parameter. If a wrong digit is selected, press **Esc** to go back one digit.

If the parameter number does not exist, the screen will display a choice between "Select a new number" or "Go to the nearest parameter number".

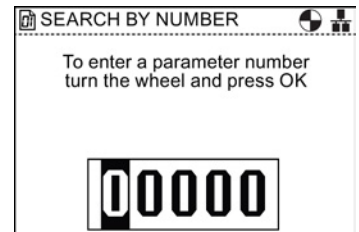

My parameters

This option allows the user to select the parameters that they wish to list. The user is presented with a list of parameters that can be selected. Once selected - only those parameters are displayed when the "My Parameters" option is selected. There are additional options that allow the user to manage their list of parameters.

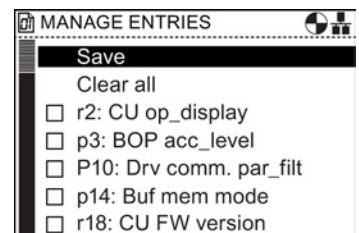

Changed parameters

When the "Changed parameters" option is selected the IOP will search the Inverter parameter list for all the parameters that have had their values changed from the factory default settings.

Once the search is complete, the screen will present a list of all parameters that have changed values.

The individual parameters can be accessed so that their current values can be displayed and modified if necessary.

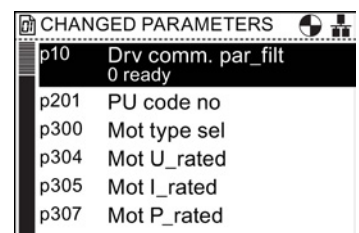

6.4 Up/Download

Overview

The upload and download options allow the user to save parameter sets to the various memory storage that is available to the system.

The following options are presented to the user:

- Panel to drive
- Drive to panel
- Delete panel parameter set
- Drive to memory card
- Memory card to drive

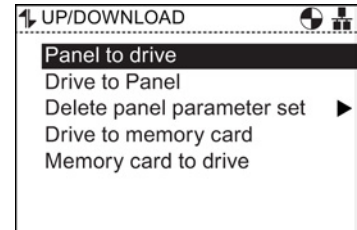

 **WARNING**

Unexpected behaviour of Inverter

During the transfer of data to and from the Inverter, it is essential that the transfer is not interrupted and the process is allowed to be completed. If the process is interrupted, it is possible that the data could be corrupted and the system may behave in an unexpected manner. Should an interruption of the transfer process occur, then it is highly recommended that a factory reset of the Inverter is performed prior to any further parameterization or giving the Inverter control of the application.

Fault screen during up/download

If during the up/download process a fault occurs and the fault screen is displayed, press **Esc** if you wish the up/download to be continued. If OK is pressed, it will cancel the up/download process.

Safety Parameters

If safety parameters are to be downloaded a function test of the safety functions has to be performed. Please refer to the "Safety Integrated Function Manual" which can be found at the hyperlink below.

6.5 Extras

Overview

The Extras menu presents a number of options for the configuration of the IOP, these are:

- Status-screen wizard
- Drive identity
- Parameter settings
- Panel settings

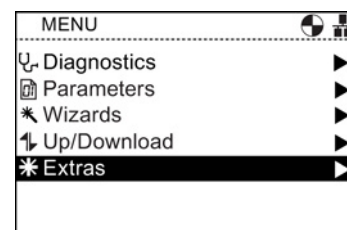

Status-screen wizard

The status-screen wizard allows the user to configure the information displayed on the status screen. By default it displays output voltage and output frequency of the Inverter. These can be changed by using the wizard to select other physical values of the Inverter. Displayed units of value can be specifically adapted using known conversion factors and with the addition of an offset value to allow the units of measure to be displayed as required for the users application.

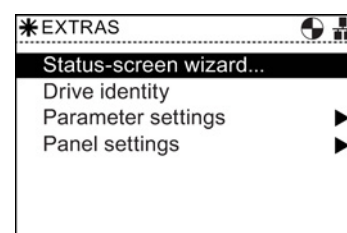

Scalar value

The bar graph (default status screen) and the Scalar value are setup using a similar procedure. The example below show how to setup the Scalar value status screen.

1. From the Set Status-Screen menu select "Scalar Value".

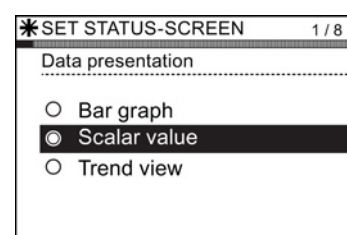

2. Select the screen position of the displayed values

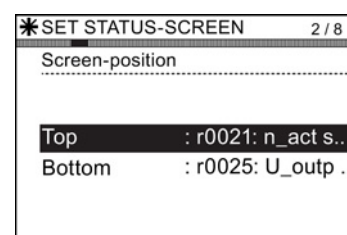

3. Select the parameter values that should be displayed on the status screen.

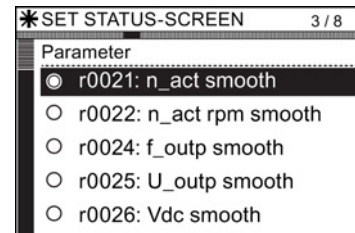

4. Select the required units of measure to be displayed on the status screen.

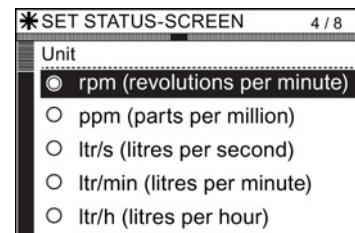

5. Select the required number of decimal places to be displayed for the chosen units of measure.

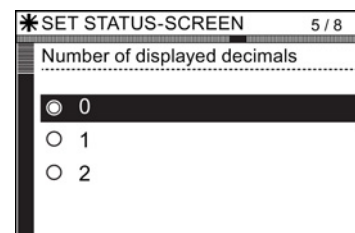

6. On completion of the user selections, a summary of the settings is displayed. If the settings are correct, then select "Continue" to move to the next step.

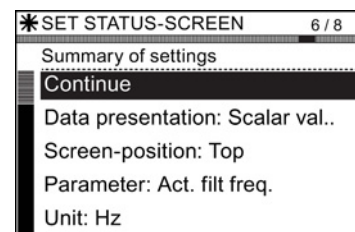

7. The option to save the settings is displayed. Select "Save" to save the settings, or select "Cancel Wizard" to exit the Wizard. If "Cancel Wizard" is selected, no changes will be saved and the Status Screen will remain unchanged from any previously set configuration. If "Save" has been selected, all changes will be saved.

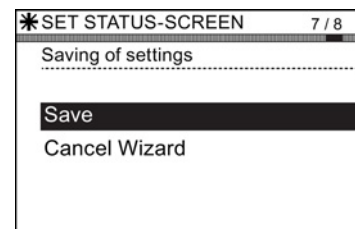

- When the save has completed successfully, the screen will automatically return to the status screen and display the new status screen as configured in the wizard.

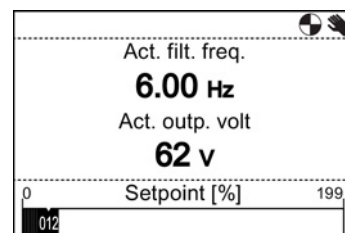

Trend view

The Trend view allows the user to configure real-time monitoring of the Inverter and display the desired values in the form of a graph. To setup the Trend view, the following steps should be performed.

- From the Set Status-Screen menu select "Trend View".

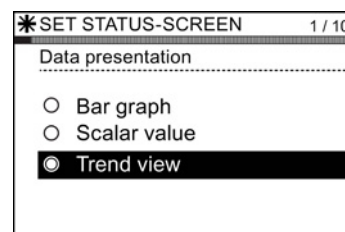

- Select the screen position of the displayed values.

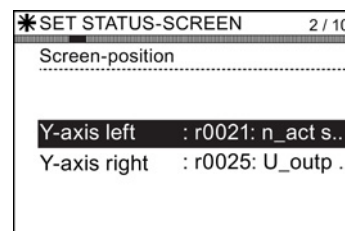

- Select the parameter values that should be displayed on the status screen.

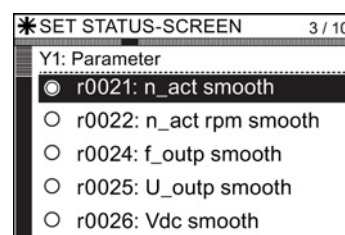

- Select the required units of measure to be displayed on the status screen.

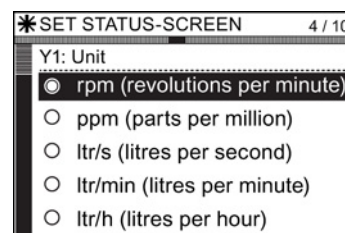

- 5. select the required number of decimal places to be displayed for the chosen units of measure.

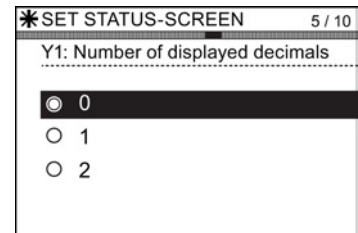

- 6. Set the range value of the Y1 axis.

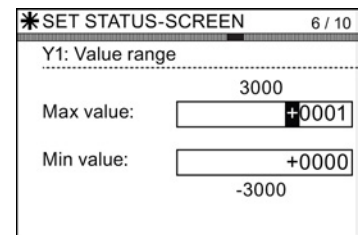

- 7. If required, the other axis (Y-axis right) can be configured.

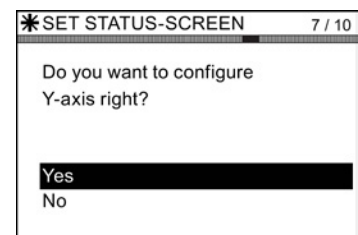

- 8. Set the required time period for the displayed Trend View.

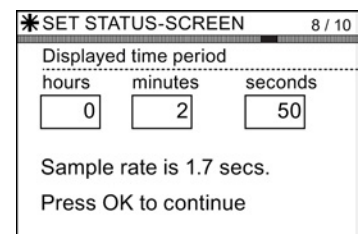

- 9. A summary of settings is displayed. If they are correct then select "Continue".

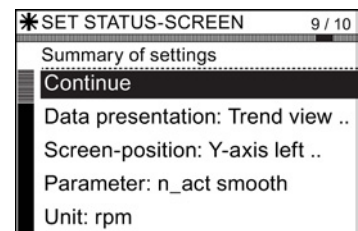

10. Select "Save" to save the settings, or select "Cancel Wizard" to exit the Wizard.
If "Cancel Wizard" is selected, all changes will be cancelled and the Status Screen will return to the last set Status Screen settings.

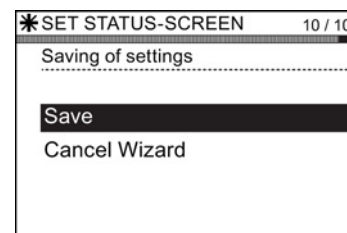

When the save has completed successfully, the screen will automatically return to the Status Screen and display the new Status Screen as configured in the Wizard.

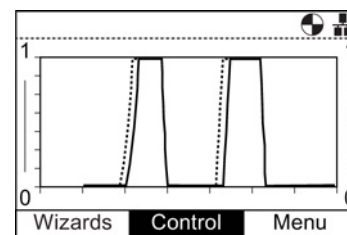

With a long press of the **INFO** button, the graph data is written to a Trend information file on the IOP. An example of the Trend information file and its location is given in the figure below.

```
Trend Information
-----
Template:
Axis:Param Number<index>:<bit>:Param Name

Left axis (Y1): r0021      : - : Act. filt. freq.
Right axis(Y2): r0025      : - : Act.outp. volt

Time period: 150 Secs.
Sample rate: 1.5 Secs.

Sample      Y1(Hz)      Y2(V)
-----
1           0.000      17.920
2           0.000      20.233
3           0.000      20.234
4           0.954      27.541
5           3.240      43.577
6           3.497      44.495
7           5.325      58.811
8           6.497      65.728
9           4.832      50.322
10          0.000      20.143
11          0.000      20.240
12          0.000      20.240
13          3.046      42.973
14          6.772      70.384
15          10.342     94.288
16          13.492    116.783
17          13.998    120.530
18          13.998    120.532
19          13.998    120.533
20          13.998    120.535
21          9.169      82.063
22          0.000      0.000
23          0.000      0.000
24          0.000      0.000
```

To access the Trend Information file, navigate to the following directory on the IOP:

/efs/health/TrendSample.txt

Figure 6-2 Trend information file

Parameter settings

Drive factory reset

The option allows the user to restore the Inverter to its factory default settings.

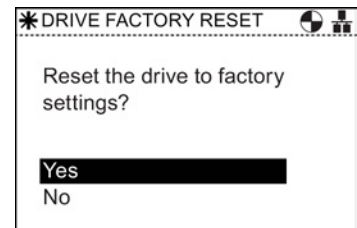

Parameter filter

This option allows the user to select the parameter access level. Standard is the default access level, which gives the user access to the most frequently used parameters. Expert level gives access to all available parameters.

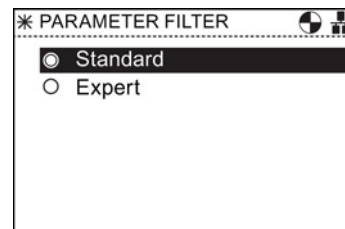

Default dataset

This option allows the user to determine which is the default command dataset when viewing or selecting a new default dataset from the options provided.

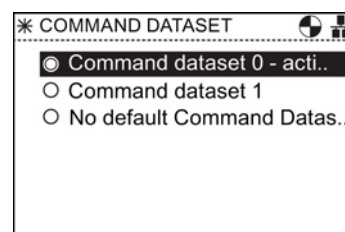
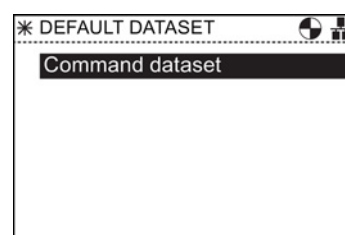

Parameter saving mode

This option allows the user to set the default location for any save function performed on the Inverter.

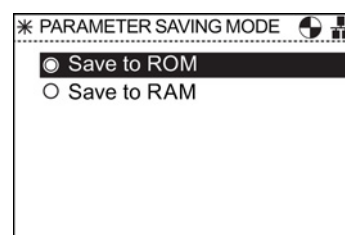

Save RAM to ROM

This option allows the user to manual save all drive data from the Inverters internal memory to the internal non-volatile memory - thus data save will be retained within the Inverter until it is overwritten.

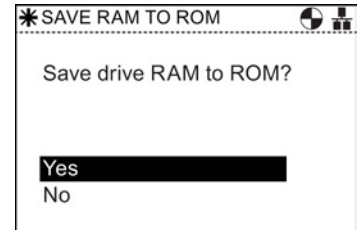

Drive identity

This option allows the user to display the technical details of the components that comprise the Inverter system. This includes the details of the Control Unit and Power Module. This is a read-only screen and cannot be modified.

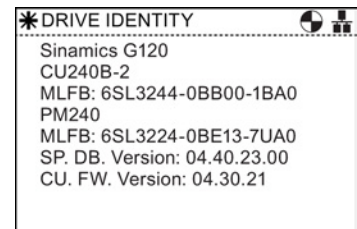

Panel settings

Language

This option allows the user to select the language that is used to display information and text on the IOP. This options has been previously described in the initial set-up section of this manual. Languages can be added or deleted using the USB connection on the IOP and a PC.

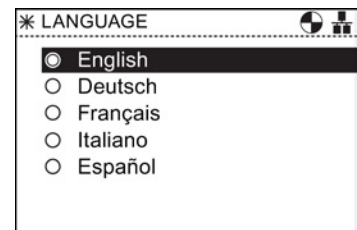

For details of selecting this function see Initial Set-up (Page 16)

Operator panel restart

Should the user wish to restart the operator panel, this option allows the IOP to be restart without the loss of any settings.

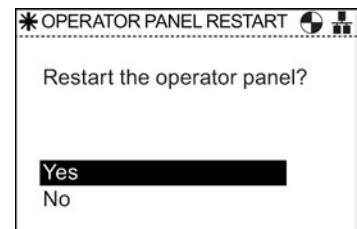

Operator panel factory reset

This option resets the IOP to its default factory settings. All previous settings stored on the IOP will be lost. Any parameter sets stored on the IOP will not be deleted.

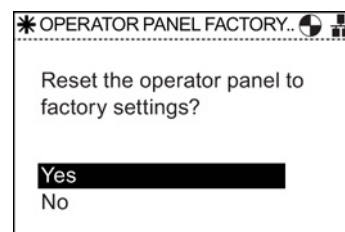

Display backlight

This option allows the user to change intensity of the display lighting.

For details of selecting this function see Initial Set-up (Page 16)

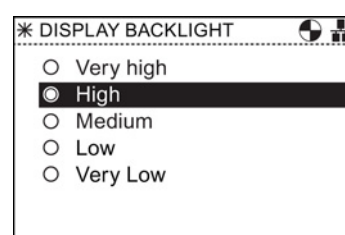

Display contrast

This option allows the user to change the contrast between black and white on the display.

For details of selecting this function see Initial Set-up (Page 16)

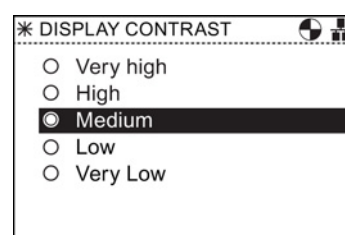

Lighting duration

The backlight display, by default, is set to automatically turn off after 60 seconds from the last key press. This time can be adjusted to 30 seconds, 60 seconds, 300 seconds or permanently on.

For details of selecting this function see Initial Set-up (Page 16)

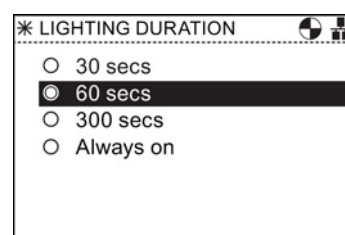

Panel identity

The panel identity screen displays the following technical information regarding the IOP:

- IOP firmware version
- menu description version
- Parameter description version
- Menu texts version
- Parameter name index version
- Wizard description version.

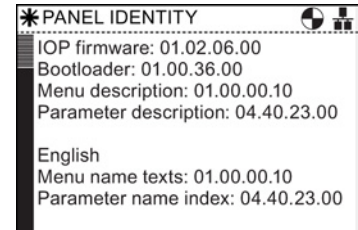

Display mode

Display mode allows the user to select the manner in which text is displayed.

- "Normal" displays black text on a white background.
- "Inverse" displays white text on a black background.

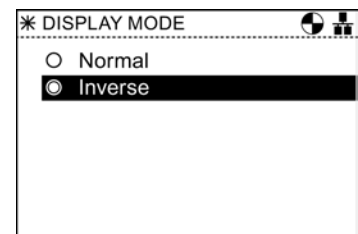

For details of selecting this function see Initial Set-up (Page 16)

6.6 Write Protection

Introduction

The write protection function has been designed to prevent the settings within the Inverter from being inadvertently changed. There is no password required to activate the write protection function.

Given in the table below is a list of the parameters that are excluded from write protection.

Table 6- 1 Parameters and functions excluded from write protection

Parameter	Function
p0003	Sets the access level to read and write parameters.
p0010	Sets the parameter filter to commission an Inverter.
p0124[0...n]	Identification of the Control Unit using an LED.
p0970	Initiates the reset of the Inverters parameters.
p0971	Saves parameters in the non-volatile memory of the Inverter.
p0972	Sets the required procedure to execute a hardware reset of the Inverter.
p2111	Maintains a count of the number of alarms that have occurred since the last reset.
p3950	Access to service parameters - only for service personnel and a password is required.
p3981	Used to acknowledge all active faults of the Inverter.

Parameter	Function
p3985	Sets the mode to change over the master control / LOCAL mode.
p7761	Activate/Deactivate write protection function.
p9400	Safely remove memory card.
p9484	BICO interconnection searches signal source.

Note

Fieldbus communications using CAN, BACnet and MODBUS

When using these fieldbus communications protocols it is still possible to change the parameter factory settings, even if the write protection function is active. To ensure that write protection, if required, is active over fieldbus communications, then parameter p7762 must be set to 1.

Activating/deactivating write protection

To activate or deactivate the write protection function, the following procedure must be performed:

1. Select "Menu" from the main screen.

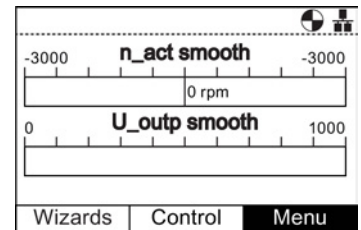

2. Select "Parameters" from the menu.

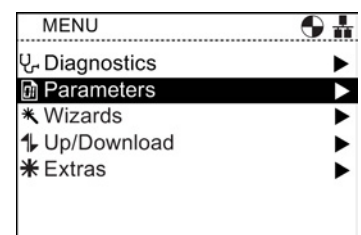

3. Select "Search by number" from the Parameters menu.

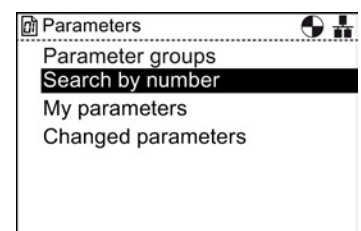

6.6 Write Protection

- 4. Input "07761" then press "OK".

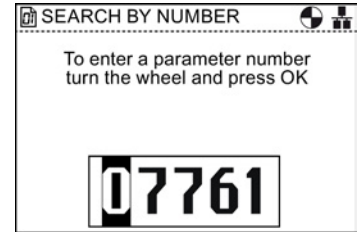

- 5. The screen will automatically display the parameter in the "All Parameters" menu. The write protection parameter is highlighted. Note that the current status of the write protection function is shown below the parameter name. Press "OK" to select the parameter.

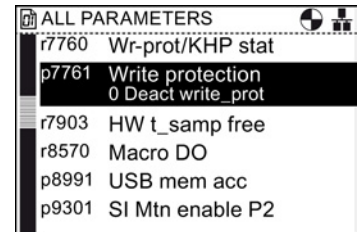

- 6. Select "1: Act wr-Protect" to activate the write protection function. Press "OK" to confirm selection.

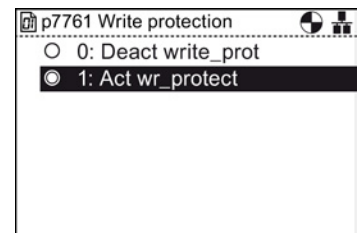

- 7. The screen returns to the "All Parameters" screen and the write protection parameter is highlighted, now showing the current status of the function as active. Press "ESC" twice to return to the "Status" screen.

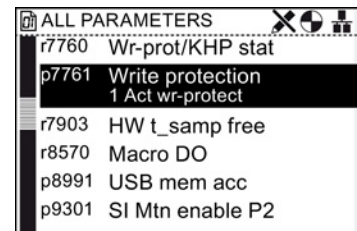

To deactivate the write protection function follow the same procedure as shown above but select "0: Deact write-prot".

6.7 Know-how Protection

Introduction

Know-how Protection (KHP) has been designed to allow machine manufacturers to completely hide all the modified parameters of the Inverter. This means that not only can these parameters not be changed, they are not visible to the end-user of the system.

Note

Technical support for active KHP

If KHP is activated and technical support is required, this will only be possible with the consent of the machine manufacturer.

Given in the table below are the parameters that are excluded from the KHP function:

Table 6- 2 Parameters and functions excluded from write protection

Parameter	Function
p0010	Sets the parameter filter to commission an Inverter.
p0918	PROFIBUS address
p0970	Initiates a reset of the drive parameters.
p0971	Saves parameters in the non-volatile memory of the Inverter.
p2030	Fieldbus int protocol selected
p2042	PROFIBUS indent number
P7766 [0...29]	KHP Password input - activates/deactivates the KHP function.
p8929	PN remote controller number
p8991	USB memory access
p8999	USB functionality
p9930 [0...8]	System logbook activation
p9931 [0...129]	System logbook module selection
p9932	Save system logbook EEPROM

Know-how Protection (KHP) parameters

Listed below are all the parameters used to activate, deactivate and modify the KHP, including a brief description of their purpose.

Table 6- 3 Know-how Protection

Parameter	Function
P7763	KHP OEM exception list number of indices for p7764. Maximum value is 500.
P7764 [0...n]	KHP OEM exception list. Sets the parameters to be excluded from the KHP function.
P7765	KHP memory card copy protection. Activates/deactivates copy protection for the memory card.
P7766 [0...29]	KHP password input. Sets the password for KHP.

Parameter	Function
P7767 [0...29]	KHP new password. Allows a new or an initial password to be created for KHP.
P7768 [0...29]	KHP password confirmation.

Activating/deactivating Know-how protection (KHP) overview

Before the KHP function can be activated for the first time the following steps should be performed (a simplified flowchart to show the process is given in the figure below).

1. The Inverter must be commissioned for the application before even attempting to activate the KHP function.
2. The application, for which the Inverter has been commissioned, must be tested to ensure that all parameter settings functioning correctly.
3. Using parameter p7763, you must set the number of parameters that can be included in the exception list. The maximum number of parameters that can be included in this list is 500.
4. Using parameter p7764, you must define a list of the parameters you wish to exclude from the KHP function; this is known as the "exception list". The exception list parameters will be visible to the end-user and they can be modified.

 CAUTION
--

Important information when implementing KHP
--

If parameter p7766 is not included or is removed from the exception list, a password can no longer be entered and KHP cannot be deactivated. If this occurs then the only way to access the parameters of the Inverter will be to perform a factory reset of all parameters.
--

5. Using parameter p7767, create a new password for the KHP function.
6. Using parameter p7768, confirm the password. Once this step has been completed the KHP function is activated.
7. The function can now be deactivated or activate by using only p7766 to input the password that has been created.

A complete example of all these individual steps is given below.

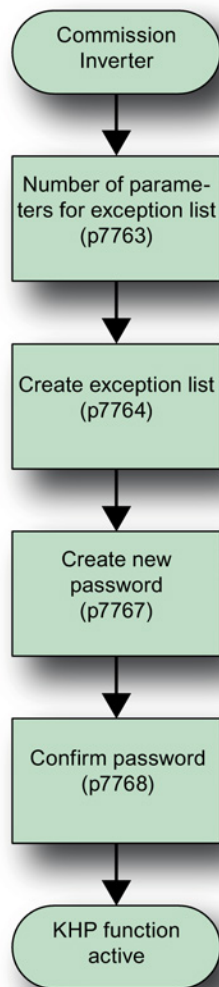
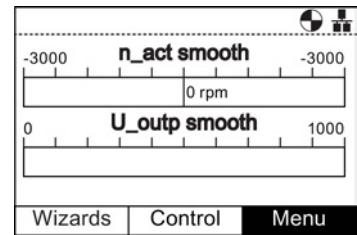

Figure 6-3 KHP function flowchart

Setting up the exception list

As previously stated, after commissioning the Inverter and checking that parameters have been set correctly, the number of parameters to be included in the exception list must be determined and set in parameter p7763. To set the number of parameters to be included in the exception list the following procedure must be performed. When establishing the first exception list, some parameters may already be entered into the exception list; under no circumstances should you remove these parameters from the exception list as these are essential parameters that must remain in the exception list.

- 1. Select "Menu" from the main screen.



- 2. Select "Parameters" from the menu.

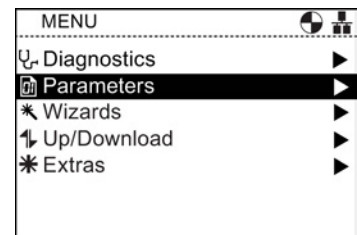

- 3. Select "Search by number" from the Parameters menu.

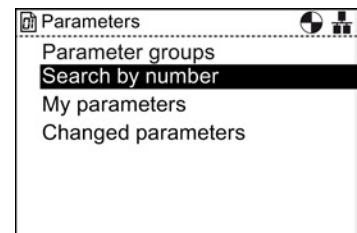

- 4. Input "07763" then press "OK"

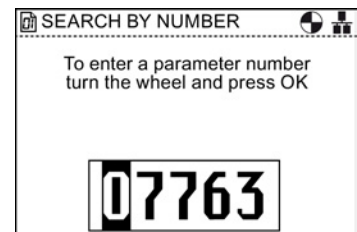

- 5. Parameter p7763 is displayed. Press "OK" to edit the parameter.

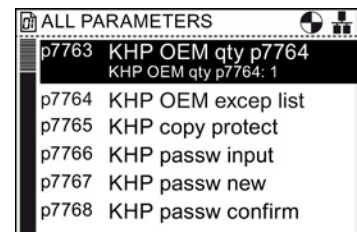

6. Input the number of parameters to be included in the exception list.
Important note: Although the maximum range shown on the screen is 65535, the maximum number of parameters in the exception list must not exceed 500.

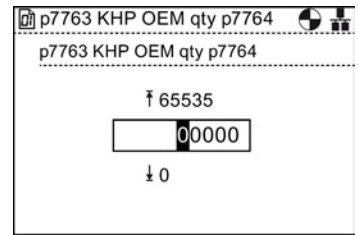

Creating the exception list

To create the list of parameters that will be included in the exception list, the following procedure should be performed:

1. Select "Menu" from the main screen.

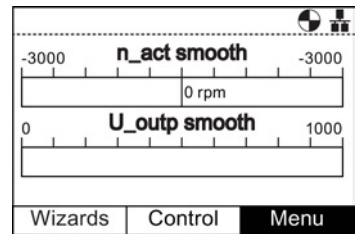

2. Select "Parameters" from the menu.

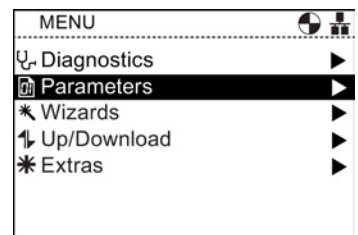

3. Select "Search by number" from the Parameters menu.

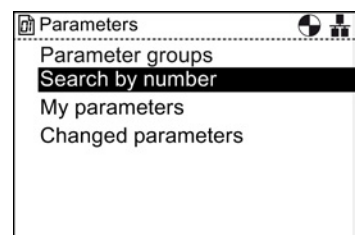

4. Input "07764" then press "OK"

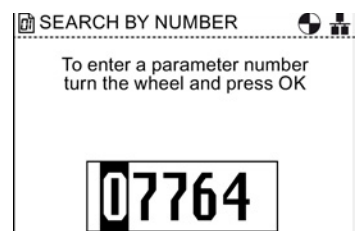

6.7 Know-how Protection

- 5. Parameter p7764 is displayed. Press "OK" to edit the parameter.

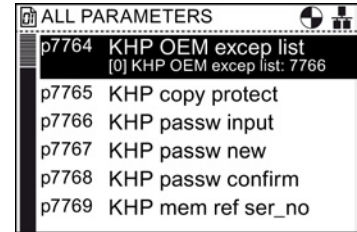

- 6. Indices "0" of P7764 is highlighted and shows that it already has the value 7766, which is the password entry parameter. This parameter must not be removed from the exception list.

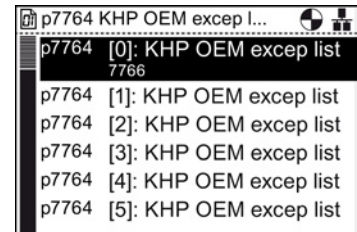

- 7. Scroll to the next Indices and press "OK"

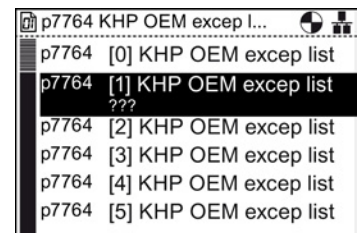

- 8. Input the parameter number to be added to the exception list. For example, 1120 for the ramp-up time parameter. Press "OK" after the final digit has been set.

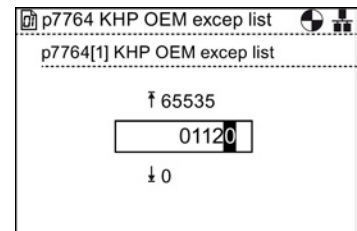

- 9. The screen will return to the indices list of p7764 and show the new value for the indices. In this example p7764 [1] has a value of 1120.

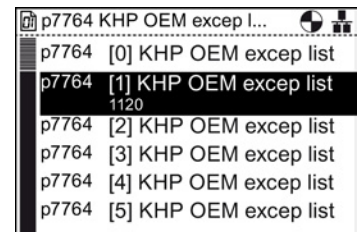

- 10. Repeat steps 7 and 8 until all the excluded parameters have been entered. When the exception list is completed, use a long press of the "ESC" key will return the IOP to the status screen.

Setting the password

When setting the password for the KHP function the user should take note of the following guidelines:

- The password can be up to thirty characters in length.
- Password entry must start with p7766 [0].
- No gaps are permissible in the password.
- Entering a password is completed when writing to p7766 [29]. Where the password is less than 30 characters in length, then p7766 [29] = 0 should be used to complete the password entry.

When entering the individual characters of the password in p7766 [0...29], each indices will contain only one character and it will be entered as a decimal code from the standard ASCII table.

For example, the password "MaC" would be entered as ASCII code in each individual indices of parameter p7766:

Character	ASCII code
M	77
a	97
C	67

It is recommend that only ASCII decimal codes between 32 and 126 are used for the password characters. An ASCII table is given in the figure below.

Code	Char	Code	Char	Code	Char
32	Space	64	@	96	`
33	!	65	A	97	a
34	"	66	B	98	b
35	#	67	C	99	c
36	\$	68	D	100	d
37	%	69	E	101	e
38	&	70	F	102	f
39	'	71	G	103	g
40	(72	H	104	h
41)	73	I	105	i
42	*	74	J	106	j
43	+	75	K	107	k
44	,	76	L	108	l
45	-	77	M	109	m
46	.	78	N	110	n
47	/	79	O	111	o
48	0	80	P	112	p
49	1	81	Q	113	q
50	2	82	R	114	r
51	3	83	S	115	s
52	4	84	T	116	t
53	5	85	U	117	u
54	6	86	V	118	v
55	7	87	W	119	w
56	8	88	X	120	x
57	9	89	Y	121	y
58	:	90	Z	122	z
59	;	91	[123	{
60	<	92	\	124	
61	=	93]	125	}
62	>	94	^	126	~
63	?	95	_		

Figure 6-4 ASCII decimal code table

To set a new password the following procedure should be performed:

The example password given previously in this section will be used as the password that will be entered as the new password.

1. Select "Menu" from the main screen.

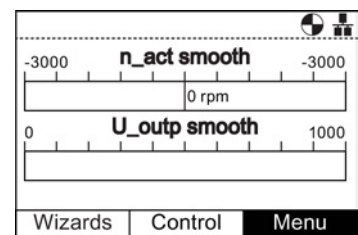

2. Select "Parameters" from the menu.

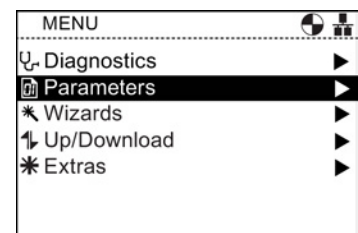

3. Select "Search by number" from the Parameters menu.

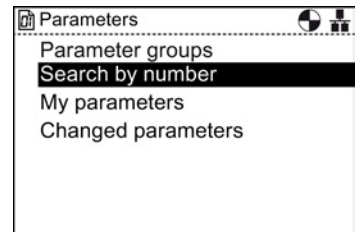

4. Input "07767" then press "OK"

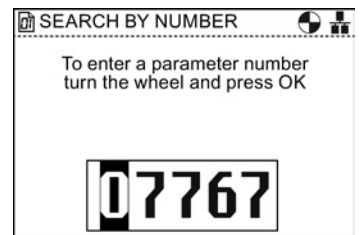

5. Parameter p7767 is displayed.
Press "OK" to edit the [0] index of the parameter.

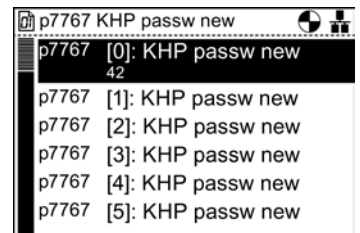

6. Enter the ASCII code for "M" (77), then press "OK"

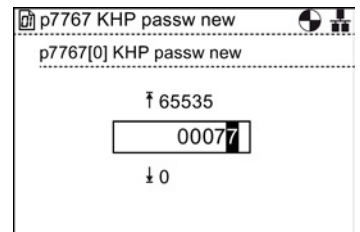

7. The screen will return to p7767 index 0 and shows the value previously set.

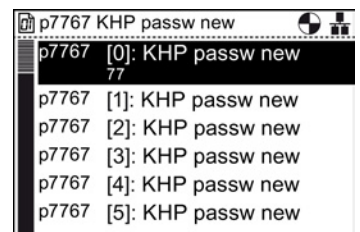

- 8. Select the next index and then press "OK" to edit the index.

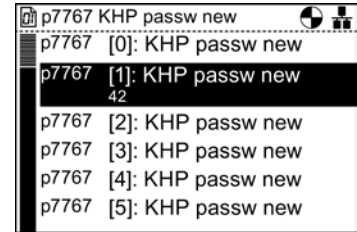

- 9. Enter the ASCII code for "a" (97), then press "OK"

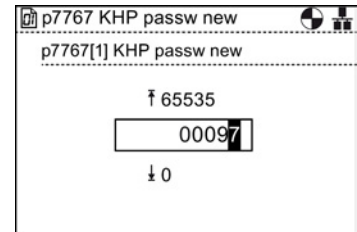

- 10. The screen will return to p7767 index 1 and shows the value previously set.

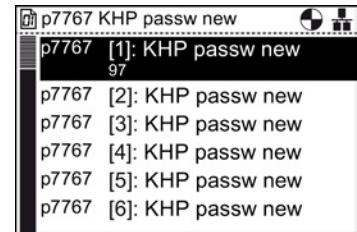

- 11. Select the next index and then press "OK" to edit the index.

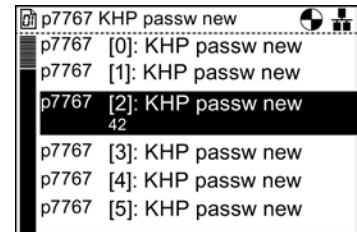

- 12. Enter the ASCII code for "C" (67), then press "OK"

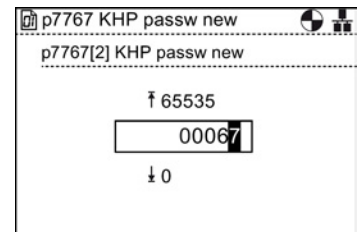

13. The screen will return to p7767 index 2 and shows the value previously set.

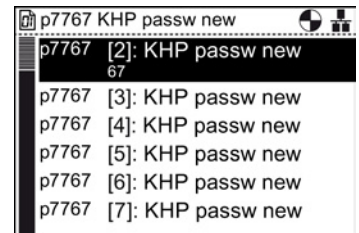

14. Scroll down to p7767 index 29 and then press "OK"

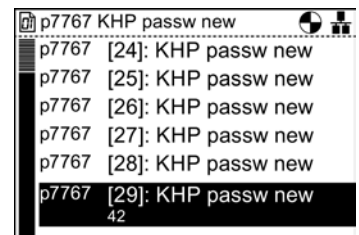

Because the password is less than 30 characters, p7767 index 29 must contain the value 0.

15. Ensure that all the digits are zero (0), then press "OK"

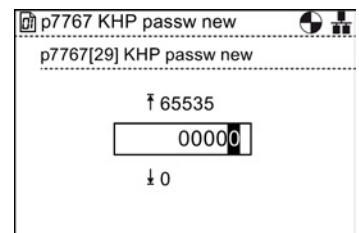

16. The screen will return to p7767 index 29 and shows the value previously set.

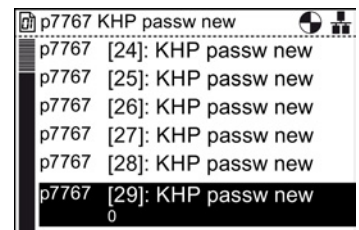

The password has now been set.

Press "ESC" to return to the "ALL PARAMETERS" list in preparation to confirm the new password.

Confirming the password

Once the new password has been entered as shown above, the password needs to be confirmed using parameter p7768. To confirm the password, the following procedure should be performed:

1. From the final screen of setting the password press "ESC" once to return to the "ALL PARAMETERS" screen.

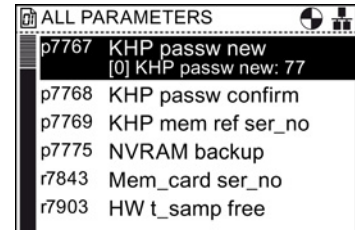

2. Scroll to parameter p7768.

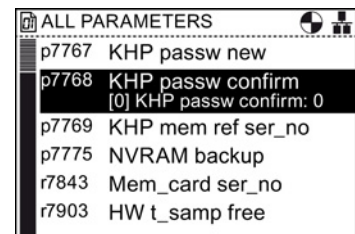

3. Press "OK" to access the parameter index 0.

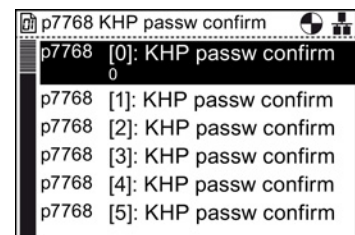

4. Enter the ASCII code for "M" (77), then press "OK"

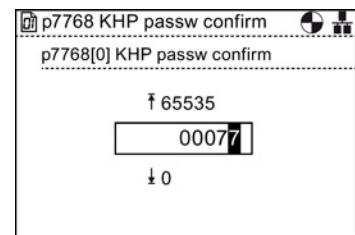

5. The screen will return to p7768 index 0 and shows the value previously set.

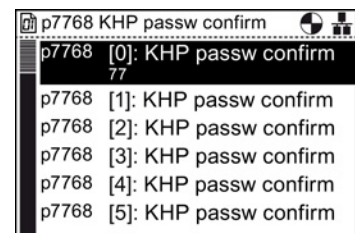

- 6. Select the next index and then press "OK" to edit the index.

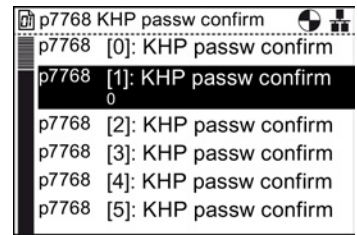

- 7. Enter the ASCII code for "a" (97), then press "OK"

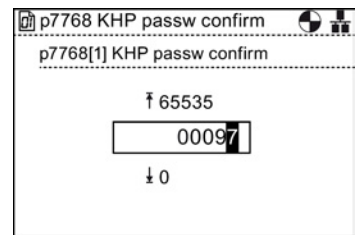

- 8. The screen will return to p7768 index 1 and shows the value previously set.

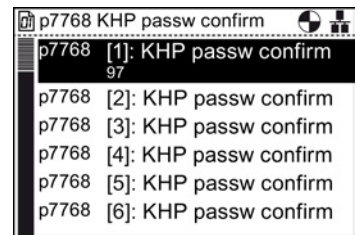

- 9. Select the next index and then press "OK" to edit the index.

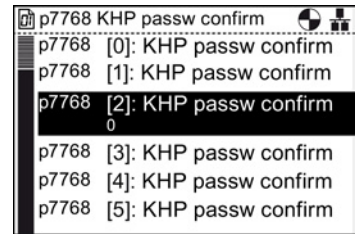

- 10. Enter the ASCII code for "C" (67), then press "OK"

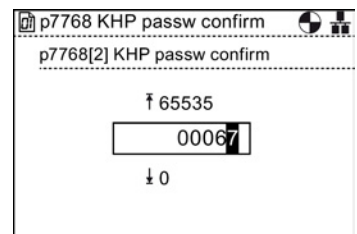

- The screen will return to p7768 index 2 and shows the value previously set.

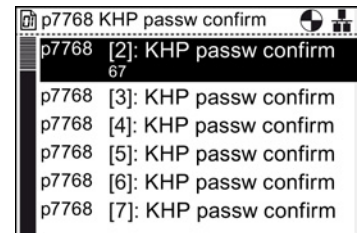

- Scroll down to p7768 index 29, and press "OK"

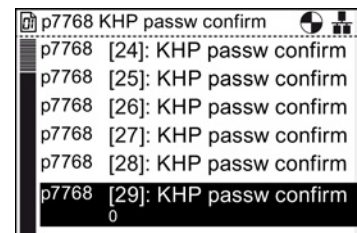

Because the password is less than 30 characters, p7768 index 29 must contain the value 0.

- Ensure that all digits are zero (0) and then press "OK"

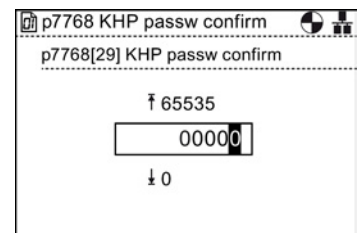

- The screen will return to p7768 index 29 and shows the value previously set.
KHP is now active and the padlock icon appears in the top right-hand side of the screen.

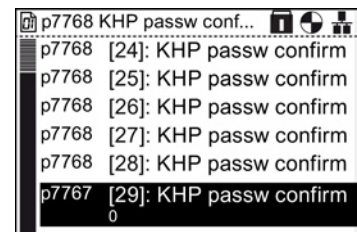

To deactivate the KHP function input the password using p7766 (KHP passw input).

Options

7.1 Door mounting kit

To allow the IOP to be mounted into the door of a cabinet, the door mounting kit (DMK) has been designed. This will allow the IOP to be fitted to the front of a panel or door and be IP54 rated.

The fitting of the DMK is accomplished as shown in the figure below.

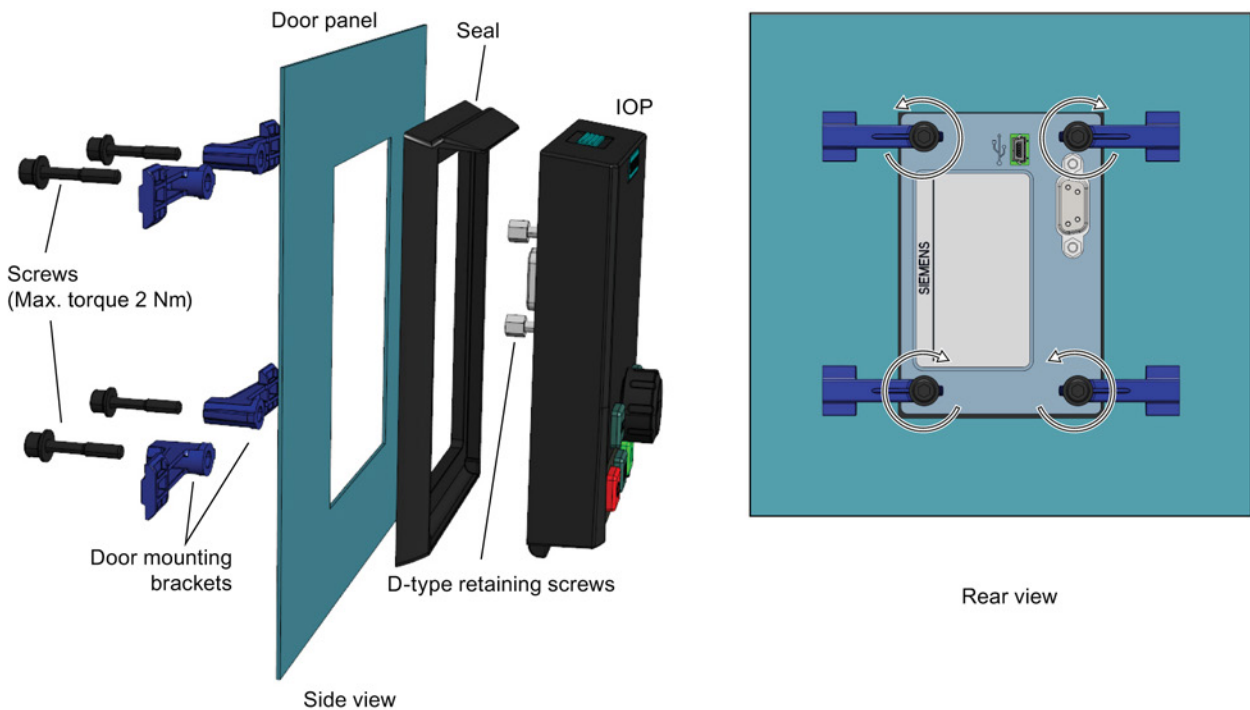

Figure 7-1 Installation of IOP door mounting kit

Prior to the installation of the DMK, it is necessary to create a hole in the panel or cabinet with the dimensions as shown in the figure below:

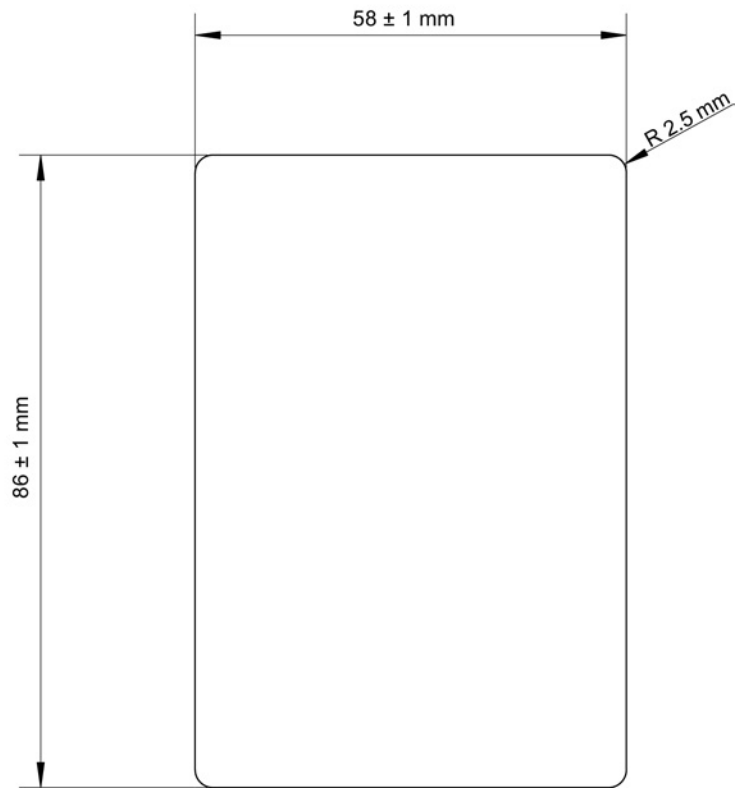



Figure 7-2 Door mounting kit drilling pattern

The depth of the panel or cabinet door should be between 1 mm to 3 mm

The IOP Door Mounting Kit can be ordered using the following order number:

6SL3256-0AP00-0JA0

7.2 Hand-held device

 WARNING
Charging unit <ul style="list-style-type: none">• The charging unit for the rechargeable batteries is contained within the hand-held device for the sole purpose of charging rechargeable batteries.• The charging unit contained within the hand-held device should not be used with standard "AA" batteries as this will result in damage to the batteries and the hand-held device.• Only the supplied power supply unit should be used with the IOP. The use of any other power supply units could seriously damage the hand-held kit.

 CAUTION
General precautions <ul style="list-style-type: none">• There is a risk of explosion if battery is replaced by incorrect type.• Overcharging, short circuiting, reverse charging, mutilation, or incineration of the cells and the batteries must be avoided to prevent one or more of the following occurrences; release of toxic materials, release of hydrogen and/or oxygen gas, rise in surface temperature.• If a cell or a battery has leaked or vented, it should be replaced immediately using protective gloves.• If and when necessary, these cells or batteries must be replaced with identical new ones from the same manufacturer. If a cell or a battery to be replaced is connected with other cells or batteries in series, it is recommended that the other cells or batteries be replaced with new ones at the same time.• Battery compartments containing these cells or batteries must be provided with means of ventilation to prevent possible accumulation of any released gases under abnormal conditions.

Note**Battery lifetime**

With the supplied rechargeable batteries in a fully-charged state they should last for approximately 10 hours; the use of normal "AA" batteries may last considerably less time.

Industrial environment

The IOP has been designed for use within a Class A Industrial environment only.

Disposal of batteries

The batteries supplied with the IOP must be disposed of in accordance with local and national environmental policies.

Battery status

The battery status is displayed at the top right-hand corner of the IOP display.

Battery charging

If the batteries are put on charge and the batteries are fully discharged; the charging unit will enter a 'pre-charge' state. During the pre-charge state the LED will not be lit, therefore there may be a delay before the charging LED lights up.

The IOP has no internal power source, so to increase the IOP's versatility, the hand-held device has been designed.

Table 7- 1 Hand-held device order information

Order number	Item quantity	Item	Remarks
6SL3255-0AA00-4HA0	1	IOP	
	1	Hand-held module	
	1	Power supply unit	
	4	Rechargeable batteries	1.2 V NiMH (see note below)
	1	RS232 cable	

Note**Battery order information**

The batteries supplied with the IOP Hand-held Kit should be replaced with exactly the same type of batteries. The order and manufacturer information is given below.

Company:GP Batteries

Order Number:GP210AAH-C4

Website:http://www.gpbatteries.com/html/products/rechargeable_hydride.html

Datasheet:<http://www.gpbatteries.com/pic/210aah.PDF>

The layout of the IOP hand-held device is shown in the figure below.

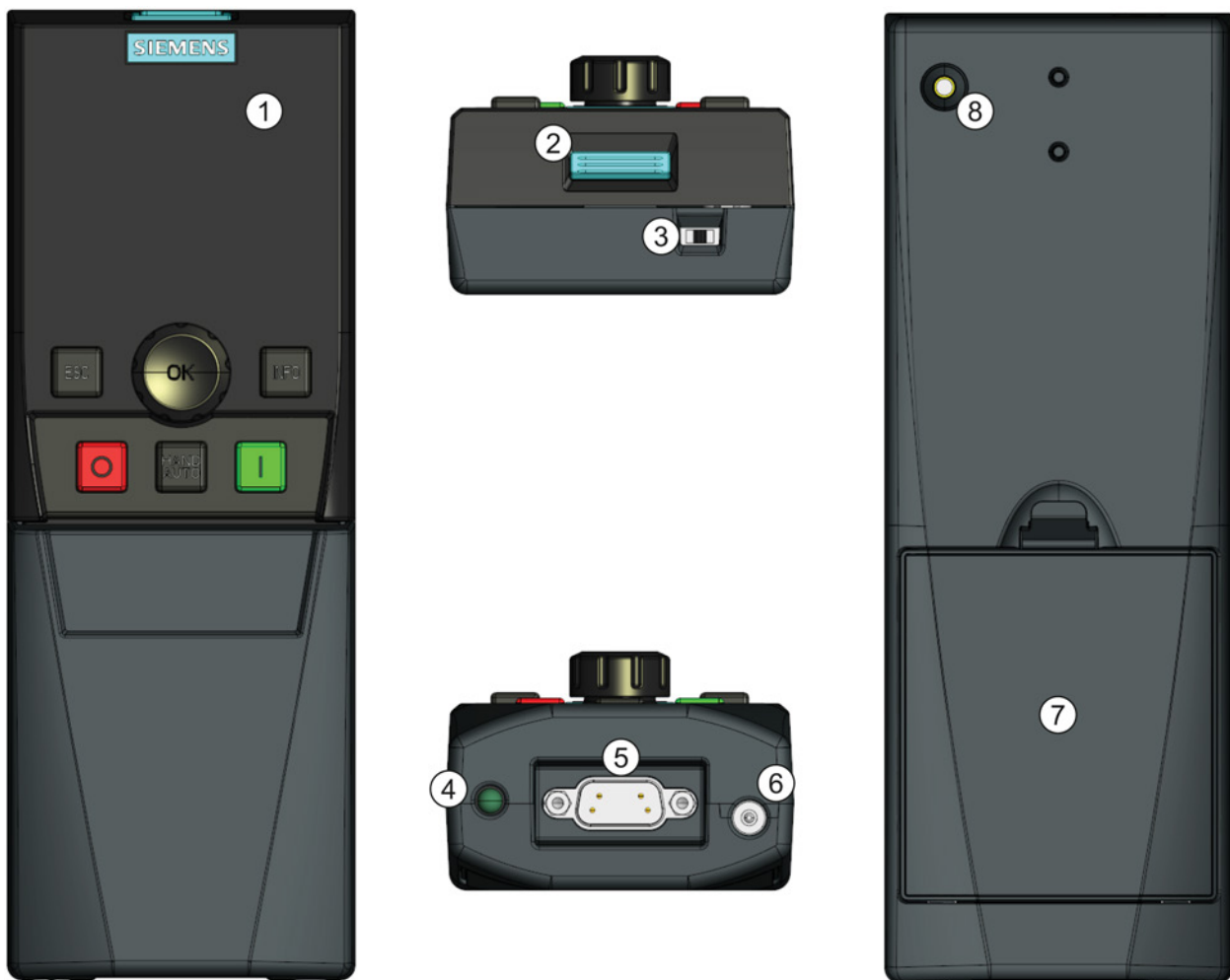

Figure 7-3 IOP hand-held kit layout

1. Intelligent Operator Panel (IOP)
2. IOP release catch
3. ON/OFF switch
4. Charging LED - ON when charging, OFF when charged
5. 9-pin Sub-D male connector (RS232)
6. Charging unit input
7. Battery compartment cover
8. IOP retaining screw

Fitting the batteries

The hand-held device is powered by four 'AA' rechargeable batteries; these batteries are supplied with the hand-held kit. The batteries are fitted as shown in the figure below.

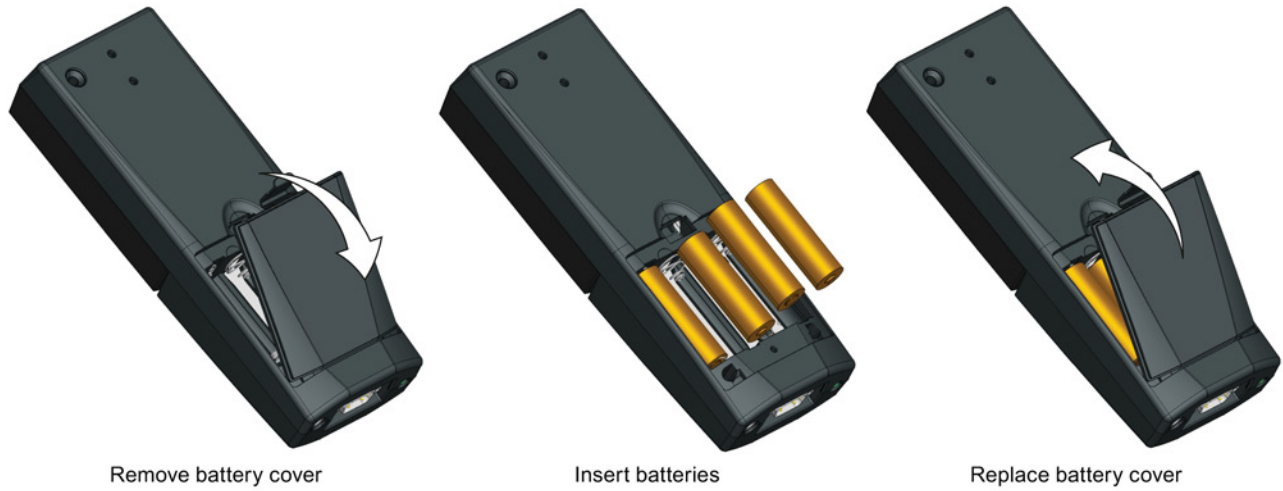

Figure 7-4 Installing batteries for handheld kit

Technical data

8.1 Technical specifications

IOP technical data

Table 8- 1 IOP and Door mounting kit specifications

Feature	IOP only	Door mounting kit
Protection	Depending upon the Control Unit IP rating to a max. of IP54	
Dimensions (HxWxD)	106.86 mm x 70 mm x 30.06 mm (Depth includes width of wheel)	
Net weight	0.134 Kg (0.295 lbs)	
Gross weight	0.206 Kg (0.454 lbs)	
Screw torque	-	Max. 2 Nm
Operating ambient temperature	0 - 50 °C (32 - 122 °F) under nominal conditions of the attached inverter.	
Transport and storage ambient temperature	-40 - +70 °C (-40 - 158 °F)	
Humidity	Maximum absolute humidity 25 g/m ³	

Table 8- 2 Hand-held specifications

Feature	IOP Hand-held kit
Protection	IP20
Dimensions (HxWxD)	195.04 mm x 70 mm x 47.99 mm
Net weight	0.724 Kg (0.1.59 lbs)
Gross weight	0.970 Kg (2.14 lbs)
Operating ambient temperature	0 - 40 °C (32 - 104 °F) [charging 10 - 40 °C]
Transport and storage ambient temperature	-20 - +55 °C (-4 - 131 °F)
Humidity	Relative humidity 90%

Index

A

- Activating/deactivating write protection, 79
- Active faults/alarms, 58
- Analog setpoint, 41
- AUTO mode, 11

B

- Basic commissioning wizard, 29

C

- Changed parameters, 67
- Communications status, 60
- Control
 - Jog, 56
 - Jog frequencies, 56
 - Reverse, 55
 - Setpoint, 54

D

- Datasets, 21
- DEMO mode, 12
- Diagnostics menu, 58
 - Active faults/alarms, 58
 - Communications status, 60
 - Drive enables, 61
 - History, 58
 - I/O simulation, 60
 - I/O status, 59
 - Identification/Maintenance, 59
- Display backlight, 19
- Display contrast, 19
- Display mode, 20
- Drive Datasets, 21
- Drive enables, 61

E

- Extra menu, 69
 - Drive identity, 76
 - Panel settings, 76

- Status-screen wizard, 69

F

- Fixed speed, 39
- functional support, 10

G

- GSD, 39, 40, 41

H

- HAND mode, 11
- Hand-Held Kit, 9
- History, 58

I

- I/O simulation, 60
- I/O status, 59
- Icons,
- Identification/Maintenance, 59
- Initial Set-up, 16
- IOP functional support, 57

J

- Jog, 56
- Jog frequencies, 56
- Jogging, 40

K

- Key
 - ESC, 11
 - INFO, 11
 - OFF, 11
 - ON, 11
- Keypad
 - Locking, 12
 - unlocking, 12
- Know-how Protection, 81
 - Activating/deactivating, 82
 - Confirming the password, 92

- Creating the exception list, 85
- Parameters, 81
- Setting the password, 87
- Setting up the exception list, 83

L

- Language selection, 17
- Lighting duration, 18

M

- macro IO pre-assignments, 38
- Menu, 57
- Menu structure,
- Motorized potentiometer, 41
- My parameters, 67

P

- P0015 IO pre-assignments, 38
- P0015 Macros, 34
- Panel settings
 - Display backlight, 77
 - Display contrast, 77
 - Display mode, 78
 - Language, 76
 - Lighting duration, 77
 - Operator panel factory reset, 77
 - Operator panel restart, 76
 - Panel identity, 78
- Parameter groups
 - All parameters, 63
 - Application functions, 66
 - Diagnostics, 66
 - Drive functions, 65
 - Fieldbus, 66
 - Inputs/Outputs, 64
 - Motor & periphery, 65
 - Motor control, 65
 - Quick commissioning, 63
 - Saving & reset, 63
 - Setpoint channels, 64
 - System Information, 64
- Parameter menu, 62
 - Changed parameters, 67
 - Drive Objects, 62
 - My parameters, 67
 - Parameter groups, 63
 - Search by number, 67
- Parameter settings, 74

- Default dataset, 75
- Drive factory reset, 74
- Parameter filter, 75
- Parameter saving mode, 75
- Save RAM to ROM, 76
- Process industry, 41
- push-wheel, 11

R

- Reverse, 55

S

- Safety function, 39, 40, 41
- Screen icons,
- Search by number, 67
- Setpoint, 54
- Setting time and date, 18
- Standard telegram 1, 40
- Status-screen wizard
 - Scalar value, 69
 - Trend view, 71

T

- Telegram 20, 41
- Telegram 352, 39
- Terminal assignment
 - USS, 42
- Three-wire control, 42
- Two-wire control, 41, 42

U

- UP/Download menu, 68
 - Delete panel parameter set, 68
 - Drive to memory card, 68
 - Drive to panel, 68
 - Memory card to drive, 68
 - Panel to drive, 68
- USB connection, 9
- USS, 42

W

- Wiring diagram
 - Compressor, 44
 - Conveyor application, 48
 - Pump and fan, 45

Pump and fan staging, 46

Wizards

Basic commissioning, 21, 24

Boost, 21, 23

Closed Loop Compressor, 21

Closed Loop Fan, 21

Closed Loop Pump, 21

Closed-loop compressor, 25

Closed-loop fan, 26

Closed-loop pump, 25

Fan staging with PID, 27

Open Loop Compressor, 21

Open Loop Fan, 21

Open Loop Pump, 21

Open-loop compressor, 26

Open-loop fan, 24

Open-loop pump, 24

PID, 21

PID controller, 24

Prerequisite actions, 43

Prerequisites, 22

Pump staging with PID, 27

Roller conveyor, 26

Roller Conveyor, 21

Safety commissioning, 28

Safety Commissioning, 21

Wiring diagrams, 43

Wizard Information, 43

Write protection, 78

Activating/deactivating write protection, 79

Siemens AG
Industry Sector
Drive Technologies
Motion Control Systems
Postfact 3180
91050 ERLANGEN
GERMANY

Copyright © Siemens AG 2013
Technical data subject to change

www.siemens.com/sinamics-g120