

MOBY[®] F

Configuration, Installation and Service

Manual

Table of Contents

General

1

Introduction to MOBY F

2

Configuration and Mounting
Guidelines

3

Mobile Data Memories

4

Read/Write Devices
Read/Write Antennas

5

Interfaces

6

Accessories

7

Documentation

A

Error Messages

B

ASCII Table

C

6GT2 497-4BA00-0EA2

Published in November 2006

Safety Guidelines

This manual contains notices which you should observe to ensure your own personal safety, as well as to protect the product and connected equipment. These notices are highlighted in the manual by a warning triangle and are marked as follows according to the level of danger:



Danger

indicates that death, severe personal injury or substantial property damage will result if proper precautions are not taken.



Warning

indicates that death, severe personal injury or substantial property damage can result if proper precautions are not taken.



Caution

indicates that minor personal injury or property damage can result if proper precautions are not taken.

Caution

indicates that property damage can result if proper precautions are not taken.

Note

draws your attention to particularly important information on the product, handling the product, or to a particular part of the documentation.

Qualified Personnel

The device/system may only be set up and operated in conjunction with this manual.

Only **qualified personnel** should be allowed to install and work on this equipment. Qualified persons are defined as persons who are authorized to commission, to ground, and to tag circuits, equipment, and systems in accordance with established safety practices and standards.

Correct Usage

Note the following:



Warning

This device and its components may only be used for the applications described in the catalog or the technical description, and only in connection with devices or components from other manufacturers which have been approved or recommended by Siemens.

This product can only function correctly and safely if it is transported, stored, set up, and installed correctly, and operated and maintained as recommended.

Trademarks

MOBY[®], SIMATIC[®] and SINEC[®] are trademarks of SIEMENS AG.

Some of the other designations used in these documents are also registered trademarks; the owner's rights may be violated if they are used by third parties for their own purposes.

Copyright © Siemens AG 1998 All rights reserved

The reproduction, transmission or use of this document or its contents is not permitted without express written authority. Offenders will be liable for damages. All rights, including rights created by patent grant or registration of a utility model or design, are reserved.

Siemens AG
Automation and Drives
Special Products, Projects Automotive Industry, Training
P.O. Box 4848, D-90327 Nuernberg

Siemens Aktiengesellschaft

Disclaimer of Liability

We have checked the contents of this manual for agreement with the hardware and software described. Since deviations cannot be precluded entirely, we cannot guarantee full agreement. However, the data in this manual are reviewed regularly and any necessary corrections included in subsequent editions. Suggestions for improvement are welcomed.

© Siemens AG 1998, 2001, 2002, 2003, 2005, 2006
Technical data subject to change.

Order No. 6GT2 497-4BA00-0EA2

Table of Contents

1	General	1-1
2	Introduction to MOBY F	2-1
3	Configuration and Mounting Guidelines	3-1
3.1	Basic Requirements	3-2
3.1.1	Transmission Window	3-3
3.1.2	Transmit Period of the MDS	3-6
3.1.3	Communication between ASM, SLG/SLA and MDS F4xx	3-7
3.1.4	Communication between ASM and User Program	3-8
3.1.5	Sample Calculation	3-9
3.2	Field Data of MDS and SLG/SLA/SIM	3-11
3.3	Relationship of Speed to Amount of Data	3-14
3.4	Installation Guidelines	3-16
3.4.1	Metal-Free Space	3-16
3.4.2	Effects on the Transmission Window	3-19
3.4.3	Reduction of Metallic Effects	3-24
3.4.4	Chemical Resistance of the Mobile Data Memories	3-27
3.5	EMC Guidelines	3-29
3.5.1	Foreword	3-29
3.5.2	General	3-30
3.5.3	Spreading of Interference	3-31
3.5.4	The FFT Command	3-34
3.5.5	Cabinet Layout	3-36
3.5.6	Avoiding Interference Sources	3-39
3.5.7	Equipotential Bonding	3-40
3.5.8	Ground Fault Monitoring with MOBY	3-41
3.5.9	Shielding the Cables	3-42
3.5.10	Basic Rules on EMC	3-44
3.6	Concept of MOBY Shielding	3-46
3.7	Cable and Plug Connector Allocation	3-48
3.7.1	Cable Configuration	3-48
3.7.2	Plug Connector Allocations	3-49
3.7.3	Connection Cables	3-53
3.7.4	Cable length	3-58
4	Mobile Data Memories	4-1
4.1	Introduction	4-2
4.2	MDS F124	4-4
4.3	MDS F125	4-7
4.4	MDS F160	4-10
4.5	MDS F415	4-13

5	Read/Write Devices	
	Read/Write Antennas	5-1
5.1	Introduction	5-2
5.2	SLG 80 ANT F5	5-3
5.3	SLG 82 Basic Device	5-11
5.4	SLG 82	5-15
5.5	SLA 81	5-21
5.6	SLA 82	5-26
6	Interfaces	6-1
6.1	Introduction	6-2
6.2	ASM 400	6-4
6.2.1	Overview	6-4
6.2.2	Hardware Description	6-8
6.2.3	SIMATIC S5 Configuration	6-11
6.3	ASM 410	6-15
6.4	ASM 450/452	6-24
6.5	ASM 470/475	6-35
6.6	ASM 473	6-46
6.7	ASM 824/850/854	6-54
6.8	Serial Interface Module – SIM	6-61
6.8.1	Overview	6-61
6.8.2	Cable and Plug Connector Allocation	6-68
6.8.3	Programming the SIM Module	6-74
6.8.4	SIM 80 ANT F5	6-75
6.8.5	SIM 82	6-82
7	Accessories	7-1
7.1	MOBY Software	7-2
7.2	MOBY Wide Range Power Pack	7-5
7.3	MOBY Hand-Held Terminal STG F	7-8
A	Documentation	A-1
B	Error Messages	B-1
B.1	General Errors	B-2
B.2	ASM-Related Errors	B-5
B.2.1	ASM 400 with FB 250	B-5
B.2.2	ASM 470 with FB 47/FC 47	B-7
B.2.3	ASM 450 with FB 240	B-9
C	ASCII Table	C-1

Figures

2-1	Overview of MOBY F components	2-2
3-1	Transmission window	3-3
3-2	Direction of movement of the MDS	3-4
3-3	Working in static operation	3-4
3-4	Working in dynamical operation	3-5
3-5	Tolerances of the side allowance of the pallet	3-9
3-6	Tolerance of the side allowance of the pallet	3-10
3-7	SLG 80 ANT F5 with MDS F415	3-14
3-8	SLA 81 with MDS F415	3-14
3-9	SLA 82 with MDS F415	3-15
3-10	Isolated mounting of ANT F5 on metal	3-17
3-11	SLA 81 mounted in metal	3-17
3-12	Flush mounting in metal: SLA 82	3-18
3-13	MDS in metal-free environment	3-22
3-14	MDS in metallic environment	3-23
3-15	Interfering metal support	3-24
3-16	Flush installation	3-25
3-17	Spreading of interference	3-31
3-18	The four kinds of interference coupling	3-33
3-19	Shielding via housing	3-36
3-20	Avoidance of interference via optimal layout	3-37
3-21	Filtering the supply voltage	3-38
3-22	Inductive interference	3-39
3-23	Equipotential bonding	3-40
3-24	Circuit diagram of the principle of grounding fault monitoring	3-41
3-25	SIMATIC PLC 100U with ASM 410	3-41
3-26	Shielding of the cables	3-42
3-27	Connection of the shield rail	3-43
3-28	Interruption of shielded cables	3-43
3-29	Simple layout with ASM 400	3-46
3-30	Layout of the ASM 470 with shield connecting element	3-47
3-31	Baring of the cable shield	3-47
3-32	Connection cable: ASM 400 ↔ SLG	3-53
3-33	Connection cable: ASM 410 ↔ SLG	3-53
3-34	Connection cable: ASM 450/452/473 ↔ SLG	3-54
3-35	Connection cable: ASM 470/475 ↔ SLG	3-54
3-36	Connection cable: PC ↔ SIM 80 ANT F5 (not for SIM 82)	3-55
3-37	Connecting cable RS 232 PC ↔ SLG	3-55
3-38	Connection cable, RS 232 PC ↔ SIM 82/ASM 824	3-56
3-39	Connection cable, SLG/SIM 82; ASM 824/850/854 ↔ SLA 81/SLA 82 ..	3-56
3-40	Extension cable, SLG/SIM 82; ASM 824/850/854 ↔ SLA 81/SLA 82 ...	3-57
3-41	24 V DC stub line SLG/SIM/ASM ↔ MOBY wide-range power pack ...	3-57
4-1	MDS F124	4-4
4-2	Dimensions of the MDS F124	4-5
4-3	Metal-free space for the MDS F124	4-6
4-4	MDS F125	4-7
4-5	Dimensions of the MDS F125	4-8
4-6	Metal-free space for the MDS F125	4-9
4-7	MDS F160	4-10
4-8	Dimensions of the MDS F160	4-11
4-9	Metal-free space for the MDS F160	4-12

4-10	MDS F415	4-13
4-11	Dimensions of the MDS F415	4-15
4-12	Metal-free space for the MDS F415	4-15
5-1	Read/write device SLG 80 ANT F5	5-3
5-2	Transmission window of the SLG 80 ANT F5	5-6
5-3	Metal-free space for SLG 80 ANT F5	5-6
5-4	Distance D for SLG 80 ANT F5	5-7
5-5	Dimensional diagram of SLG 80 ANT F5	5-8
5-6	Dimensional drawing of the spacer kit for MOBY F ANT F5	5-9
5-7	Installation drawing for spacer kit	5-10
5-8	Read/write, SLG 82 basic device	5-11
5-9	Serial interface of the SLG 82 basic device to the SLA	5-13
5-10	Serial interfaces of the SLG 82 basic device to the user	5-13
5-11	Dimensional drawing of SLG 82 basic device without mounting holes ...	5-14
5-12	Mounting drawing of the adapter floor plate	5-14
5-13	Read/write device SLG 82	5-15
5-14	Transmission window of SLG 82 with SLA 81	5-17
5-15	Metal-free space for SLG 82 with SLA 81	5-17
5-16	Distance D: SLG 82	5-18
5-17	Serial interface of SLG 82 to SLA 81	5-18
5-18	Serial interface of SLG 82 to user	5-19
5-19	Drawing of SLG 82's housing	5-19
5-20	Drawing of antenna for SLG 82 (SLA 81)	5-20
5-21	Drawing of mounting of adapter floor plate	5-20
5-22	Read/write device SLA 81	5-21
5-23	Transmission window of SLA 81	5-23
5-24	Metal-free space for SLA 81	5-23
5-25	Distance D: SLA 81	5-24
5-26	Dimensional drawing of SLA 81	5-24
5-27	Dimensional drawing of the mounting clamp	5-25
5-28	Drawing of mounting of SLA 81 with mounting clamp	5-25
5-29	SLA 82 read/write antenna	5-26
5-30	Transmission window of the SLA 82	5-28
5-31	Metal-free area of SLA 82	5-28
5-32	Distance D: SLA 82	5-29
5-33	Dimensional drawing of SLA 82	5-29
6-1	Configurator of ASM 400	6-4
6-2	Plug connectors and their assignment for ASM 400	6-8
6-3	Switches and plug-in jumpers for ASM 400	6-9
6-4	Settings on the channel module	6-10
6-5	CR 700-0LA module rack (S5-115U)	6-11
6-6	CR 700-0LB module rack (S5-115U)	6-11
6-7	CR 700-1 module rack (S5-115U)	6-11
6-8	CR 700-2 module rack (S5-115U)	6-12
6-9	CR 700-3 module rack (S5-115U)	6-12
6-10	ER 701-3 module rack (S5-115U)	6-12
6-11	S5-135U/-155U central controller	6-13
6-12	S5-155U/-155H central controller	6-13
6-13	EG S5-183U expansion device for S5-135U/-155U	6-13
6-14	EG S5-184U expansion device for S5-135U/155U	6-14
6-15	EG S5-185U expansion device for S5-135U/155U/155H	6-14
6-16	EG S5-187U expansion device for S5-135U/155U	6-14
6-17	Configurator for ASM 410 in SIMATIC S5	6-15

6-18	Configurator for ASM 410 in ET 100U	6-19
6-19	ASM 410 interface with operational and indicator elements	6-20
6-20	Wiring of one or two SLGs for ASM 410	6-23
6-21	ASM 450/452 interface	6-24
6-22	Configurator of ASM 450/452	6-28
6-23	Connection plug, ASM 450/452 ↔ SLG (6GT2 090-0BC00)	6-29
6-24	Connection cable, ASM 450/452 ↔ SLG (6GT2 491-1C...)	6-29
6-25	PROFIBUS cable with 24 V power	6-30
6-26	SLG and DI/DO configuration for ASM 450/452	6-31
6-27	Dimensional drawing of the ASM 450/452	6-31
6-28	Pin allocation and LEDs of ASM 450/452	6-32
6-29	Length of baring for a PROFIBUS cable	6-33
6-30	Setting the PROFIBUS address and circuiting the terminating resistance	6-34
6-31	ASM 470/475 interface	6-35
6-32	Configurator for ASM 470/475	6-36
6-33	Front plate and inside of the front door of the ASM 470/475	6-41
6-34	Wiring of ASM 470/475 to SLG (6GT2 091-0E...)	6-43
6-35	Baring of the cable shield when customer makes own cable	6-43
6-36	ASM 470/475 directory in the hardware catalog	6-44
6-37	ASM 473 interface	6-46
6-38	Configurator for an ASM 473	6-49
6-39	Maximum configuration of ASM 473 on an ET 200X	6-51
6-40	Pin assignment and LEDs of ASM 473	6-52
6-41	Dimensions for mounting holes for basic and expansion modules	6-53
6-42	ASM 824/850/854 interface module	6-54
6-43	Configurator for ASM 824, ASM 850 (only with 1 x SLA 8x) and ASM 854	6-56
6-44	Serial interfaces of the ASM 824/850/854 to SLA 81	6-58
6-45	Serial interface of ASM 824/850/854 to user	6-59
6-46	Drawing of ASM 824/850/854 with mounting holes	6-60
6-47	Drawing of adapter floor plate	6-60
6-48	Example of a configuration for SIM	6-61
6-49	Configuration byte 0	6-65
6-50	Configuration byte 1	6-65
6-51	Standard cabling for computer/SIM 80 ANT F5, RS 232	6-72
6-52	Standard cabling for computer/SIM 82, RS 232	6-72
6-53	Standard cabling for computer/SIM 82, RS 422	6-73
6-54	DI/DO cabling with voltage supply for SIM 80 ANT F5	6-73
6-55	SIM 80 ANT F5 serial interface module	6-75
6-56	Transmission window of the SIM 80 ANT F5	6-79
6-57	Metal-free space for SIM 80 ANT F5	6-79
6-58	Distance D for SIM 80 ANT F5	6-80
6-59	Dimensional diagram of SIM 80 ANT F5	6-81
6-60	Serial interface module SIM 82	6-82
6-61	Transmission window of SIM 82	6-84
6-62	Metal-free space for SIM 82	6-85
6-63	Distance D: SIM 82	6-86
6-64	Serial interface of SIM 82 to SLA 81	6-86
6-65	Serial interface of SIM 82 to user	6-87
6-66	Dimensional drawing of the SIM 82 housing	6-88
6-67	Dimensional drawing of antenna for SIM 82 (SLA 81)	6-88
6-68	Drawing of mounting of adapter floor plate	6-89

7-1	MOBY wide range power pack	7-5
7-2	Plug connector allocation of 24 V output	7-6
7-3	Dimensions of the MOBY wide range power pack	7-7
7-4	MOBY STG F hand-held terminal	7-8
7-5	Hardware of the STG F	7-10

Tables

2-1	Technical data of MOBY F	2-1
3-1	Constant time K and t_{Byte}	3-7
3-2	Transmission time of ID number MDS F1xx/MDS F4xx, starting at address 0	3-7
3-3	Maximum transversal speed for reading the ID number	3-8
3-4	Field data of all MDSs and SLGs/SLAs/SIMs (ANT F5 with 100-mm distance to metal)	3-11
3-5	Minimum distance from MDS to MDS	3-12
3-6	Minimum distance from antenna to antenna with MDS 4xx (r/w)	3-12
3-7	Minimum distance from antenna to antenna with MDS 1xx (r/o)	3-13
3-8	Reduction of field data in %: MDS and SLG/SIM with ANT F5 (See figures 3-13/3-14.)	3-19
3-9	Reduction of the field data by mounting in metal (in %): MDS and SLG 82/SIM 82/SLA 81	3-20
3-10	Reduction of the field data by mounting in metal (in %): MDS with SLA 82	3-21
3-11	Chemical resistance of data memories made of fiber glass reinforced epoxy resin (MDS F124/F125/F415)	3-27
3-12	Interference sources: Origin and effects	3-32
3-13	Causes of coupling paths	3-33
3-14	Parameterization of the MOBY F operating modes for the FFT command	3-35
3-15	Voltage supply of the SLG/SIM 80 ANT F5 and SLG/SIM 82	3-48
3-16	Maximum ripple of the supply voltage for SLG/SIM 80 (based on frequency range)	3-49
3-17	Plug connector allocation of the SLG/SIM 80 ANT F5/SLG 82 plug connector (pin housing side)	3-49
3-18	Plug connector allocation of the 9-pole submin D (socket housing side) .	3-50
3-19	Plug connector allocation of the 9-pole submin D (socket housing side)	3-50
3-20	Plug connector allocation of SLA plug connector (pin housing side)	3-51
3-21	Plug connector allocation of the 9-pole submin D (socket housing side)	3-51
3-22	Ordering data for counterplug IP65	3-51
3-23	Plug connector allocation of 4-pole voltage supply plug connector (pin housing side)	3-52
3-24	Ordering data for voltage supply plug	3-52
3-25	Ordering data for MOBY cables	3-58
4-1	Overview of the MDS	4-2
4-2	Operational requirements/environmental requirements of MDS	4-3
4-3	Ordering data for MDS F124	4-4
4-4	Technical data of MDS F124	4-4
4-5	Field data of MDS F124	4-5
4-6	Ordering data for MDS F125	4-7
4-7	Technical data of MDS F125	4-7
4-8	Field data of MDS F125	4-8
4-9	Ordering data for MDS F160	4-10
4-10	Technical data for MDS F160	4-10
4-11	Field data for MDS F160	4-11
4-12	Ordering data for MDS F415	4-13

4-13	Technical data of MDS F415	4-13
4-14	Memory organization of the MDS F4xx	4-14
4-15	Field data of MDS F415	4-14
5-1	Overview table, SLG/SLA	5-2
5-2	Ordering data for the SLG 80 ANT F5	5-3
5-3	Technical data of SLG 80 ANT F5	5-3
5-4	Field data of SLG 80 ANT F5	5-5
5-5	Ordering data for spacer kit MOBY F ANT F5	5-9
5-6	Ordering data for the SLG 82 basic device	5-11
5-7	Technical data of the SLG 82 basic device	5-12
5-8	Ordering data of the SLG 82	5-15
5-9	Technical data of the SLG 82	5-15
5-10	Field data of SLG 82	5-17
5-11	Ordering data of the SLA 81	5-21
5-12	Technical data of the SLA 81	5-21
5-13	Field data of SLA 81	5-22
5-14	Ordering data of the SLA 82	5-26
5-15	Technical data of the SLA 82	5-26
5-16	Field data of the SLA 82	5-27
6-1	Overview of the interfaces	6-2
6-2	Ordering data of ASM 400	6-5
6-3	Technical data of ASM 400	6-6
6-4	Address settings for ASM 400 with FB 250/252	6-9
6-5	Ordering data of ASM 410	6-16
6-6	Technical data of ASM 410	6-17
6-7	Status and error LEDs of ASM 410	6-21
6-8	Operating modes for ASM 410	6-22
6-9	Ordering data for ASM 450/452	6-25
6-10	Technical data of ASM 450/452	6-26
6-11	LEDs for PROFIBUS diagnostics	6-33
6-12	Ordering data for ASM 470/475	6-37
6-13	Technical data of ASM 470/475	6-38
6-14	Function of the LEDs on ASM 470/475	6-42
6-15	Additional LEDs on the ASM 475	6-42
6-16	Ordering data of ASM 473	6-47
6-17	Technical data of ASM 473	6-47
6-18	Prerequisites for operation of the ASM 473	6-50
6-19	Ordering data of the ASM 824/850/854	6-55
6-20	Technical data of the ASM 824/850/854	6-57
6-21	Memory organization for SIM 80 ANT F5 with MDS F4xx	6-62
6-22	Memory organization for SIM 82 with MDS F4xx	6-62
6-23	Configuration of the delivered MDS F4xx transponders	6-66
6-24	Field data of all MDSs and SIMs without effects of metal	6-67
6-25	Minimum distance from MDS to MDS	6-67
6-26	Minimum distance from antenna to antenna with MDS F4xx (r/w)	6-68
6-27	Minimum distance from antenna to antenna with MDS F1xx (r/o)	6-68
6-28	Plug connector allocation of the 9-pole submin D (pin housing side)	6-68
6-29	Plug connector allocation of the 9-pole submin D (socket housing side)	6-69
6-30	Plug connector allocation of the 9-pole submin D (socket housing side)	6-69
6-31	Plug connector allocation of SLA plug connector (pin housing side)	6-70
6-32	Plug connector allocation of 4-pole voltage supply plug connector (pin housing side)	6-70

6-33	Voltage supply of the SIM	6-71
6-34	Max. ripple of the supply voltage for SIM 80 ANT F5 (based on frequency range)	6-71
6-35	Ordering data for the SIM 80 ANT F5	6-75
6-36	Technical data of SIM 80 ANT F5	6-76
6-37	Field data of SIM 80 ANT F5	6-77
6-38	Ordering data for SIM 82	6-82
6-39	Technical data of SIM 82	6-82
6-40	Field data of SIM 82	6-84
7-1	Ordering data for MOBY software	7-4
7-2	Ordering data for MOBY wide range power pack	7-5
7-3	Technical data of MOBY wide range power pack	7-5
7-4	Ordering data of STG F	7-11
7-5	Technical data for STG F hand-held terminal	7-11
B-1	General errors	B-2
B-2	Error messages of FB 250	B-5
B-3	Error messages of FB 47/FC 47	B-7
B-4	Error messages of FB 240	B-9

General

1

This configuration, installation and service manual will help you to plan and configure your MOBY F system. It covers the guidelines on configuration and installation and provides complete technical data on the individual components.

Technical support

The specialists of Technical Support are ready to advise and support you when you have questions on the functions and handling of our MOBY products.

You can reach us around the clock anywhere in the world.

Telephone: +49 (0) 180 5050-222

Fax: +49 (0) 180 5050-223

E-mail: adsupport@siemens.com

Internet

General news on MOBY F or an overview of our other identification systems are available on the Internet under the following address.

<http://www.siemens.de/moby>

Introduction to MOBY F

MOBY F is an RF identification system for optimization of material flow primarily in the sectors of storage, commissioning and logistics. This family of products includes powerful read/write devices (SLGs) which, together with mobile data memories (MDSs), permit wide read/write distances. The MDSs are available in both fixed-code and write-access EEPROM memories.

As with all MOBY systems, the user-friendly link to the SIMATIC is provided by interface modules (ASMs). So-called serial interface modules (SIMs) are available for links to PCs, EDP systems and controllers other than SIMATIC. These modules are actually SLGs equipped with communications intelligence to which a documented communications protocol has been added to ensure a high degree of flexibility.

Principal application areas

MOBY F is primarily used when product, packaging and parts identification must be inductive (i.e., without contact), reliable and fast. Long read/write distances combined with the selection of the MDS model ensure a high degree of flexibility in the following fields.

- Storage technology/commissioning
- Logistics and distribution
- Material flow control
- Parts identification

Technical data of MOBY F

Table 2-1 Technical data of MOBY F

Storage capacity MDS F4xx MDS F1xx	Depending on type: 256-byte EEPROM ¹ 40-bit fixed-code
Data organization	Address-oriented
Protection rating	IP65 to IP67
Operating temperature	-25° to +100° C
Data transmission speed (SLG - MDS)	≥ 6 msec/byte read-accesses ≥ 10 msec/byte write-accesses
Read/write distance	0 to 420 mm
Can be connected to	SIMATIC S5/S7, PCs, EDP systems, PLCs of other manufacturers, and PROFIBUS

¹ 192-byte EEPROM can be used with SLG. 224-byte EEPROM can be used with SIM.

Overview of MOBY F components

- MDS: (mobile data memory)
- SLA: (read and write antenna)
- SLG: (read/write device)
- SIM: (serial interface module)
- ASM: (interface module)
- STG F: (service and test device)

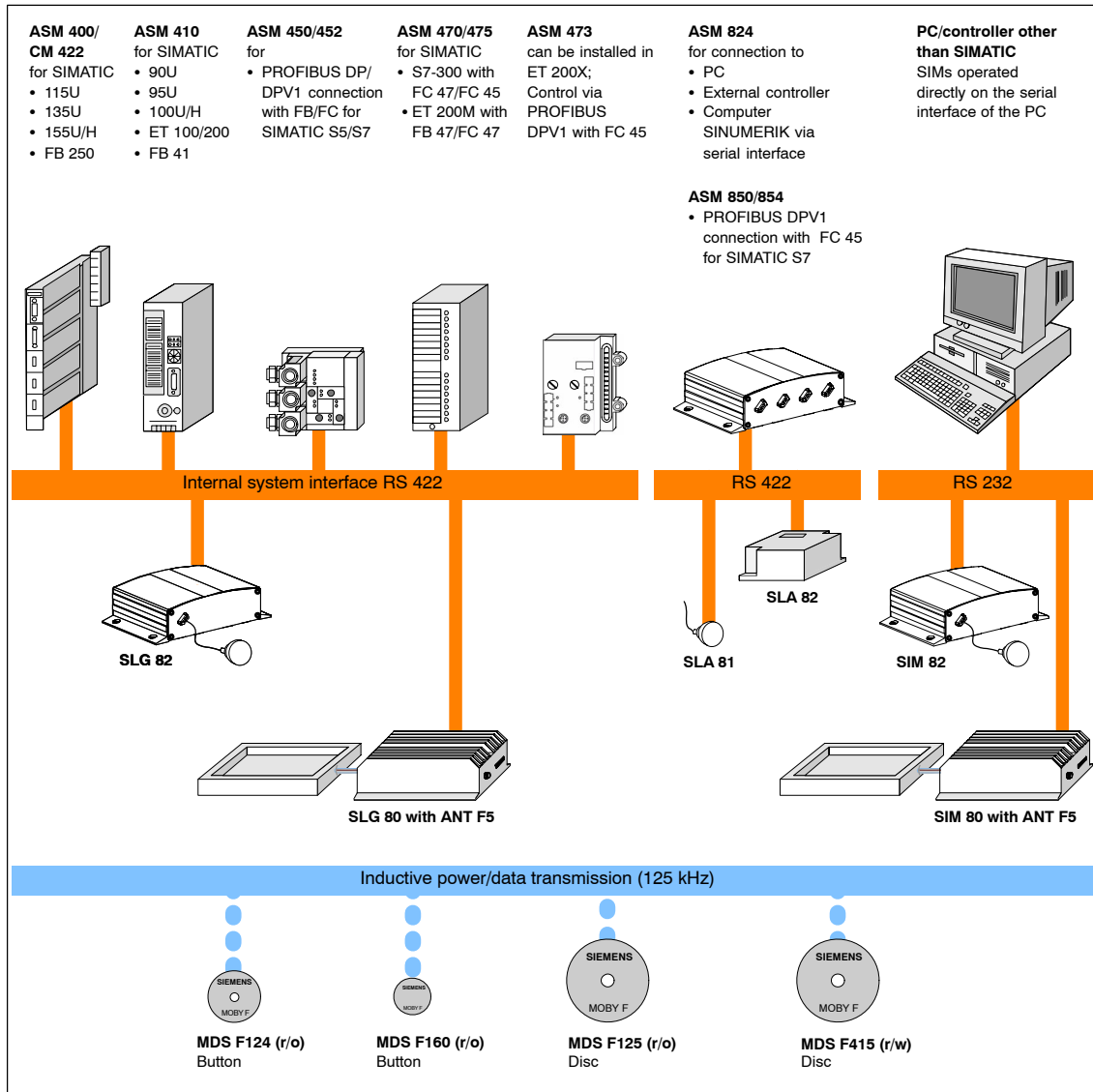

Figure 2-1 Overview of MOBY F components

Configuration and Mounting Guidelines

3

3.1 Basic Requirements



Warning

Do not make changes to the devices.
Violation will invalidate interference emission certification (BZT, FCC), CE and the manufacturer's warranty.

To choose the correct MOBY F components, apply the following criteria to your particular application:

- Transmission distance (i.e., read/write distance)
- The amount of data to be transferred
- Metal-free spaces for MDS and SLG/SLA (antenna)
- Static or dynamic transmission of the data
- Speed for dynamic transmission
- Tolerances of the tracking
- Environmental conditions (e.g., moisture, temperature, chemical effects, and so on)
- Maximum write frequency per MDS

3.1.1 Transmission Window

The read/write device (i.e., SLG/SLA) generates an inductive alternating field. The field is strongest in the vicinity of the SLG and decreases in strength the further away from the SLG it moves. Distribution of the field depends on the layout and geometry of the antennas on the SLG/SLA and the MDS.

MDS functionality requires a minimum field strength on the MDS achieved at a distance of S_g from the SLG/SLA. The figure below shows the transmission window between the MDS and the SLG/SLA.

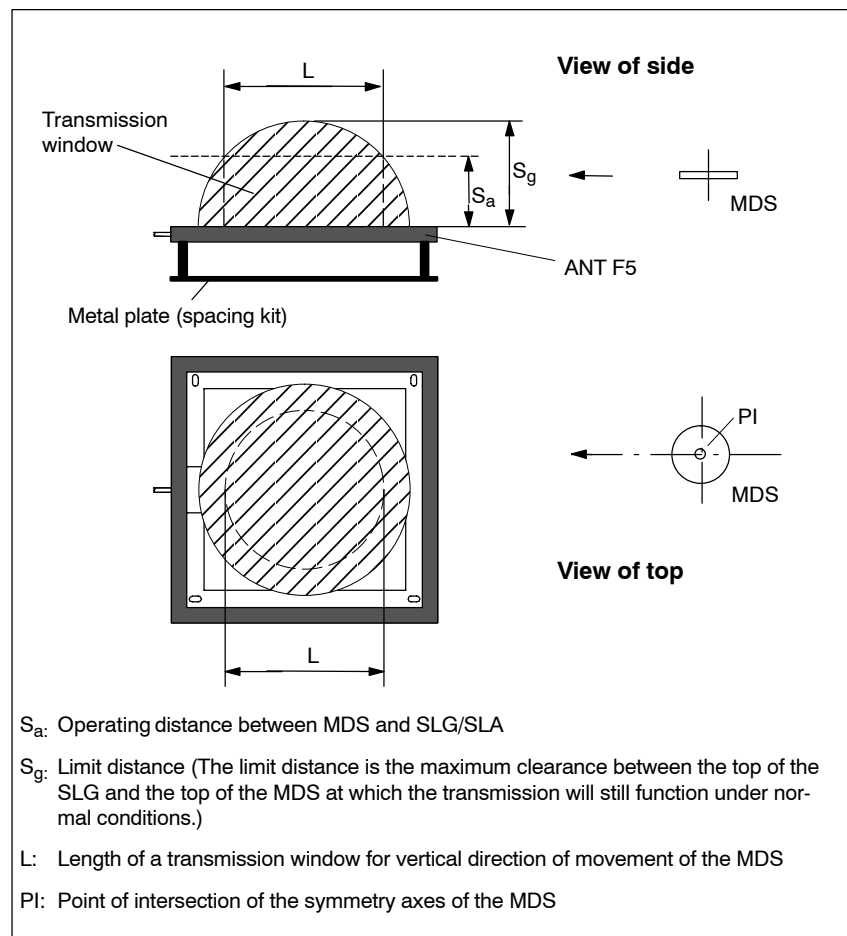

Figure 3-1 Transmission window

The active field to the MDS is a circle. Cf. view of top. The MDS can be processed as soon as the point of intersection (IP) of the MDS enters the circle of the transmission window. Direction of MDS movement and rotation can be disregarded.

The above figure also shows that operation in the area between S_a and S_g is possible. The greater the distance, the smaller the active working area becomes until it is reduced to one point at distance S_g . For this reason, only static operation should be used in the area between S_a and S_g .

Direction of movement of the MDS

The MDS and the SLG do **not** have a polarization axis (i.e., the MDS can come from any direction, assume any position and cross the transmission window). The data of the transmission window do not change. The active area is shown below.

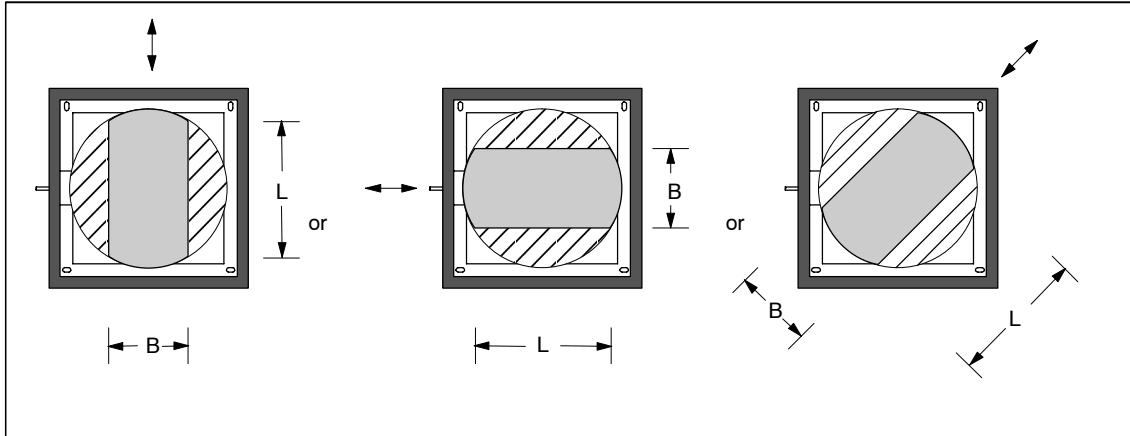

Figure 3-2 Direction of movement of the MDS

Working in static operation

When static operation is used, the MDS can be processed into the area of the limit distance (i.e., S_g). The MDS must be positioned exactly over the SLG/SLA as shown below.

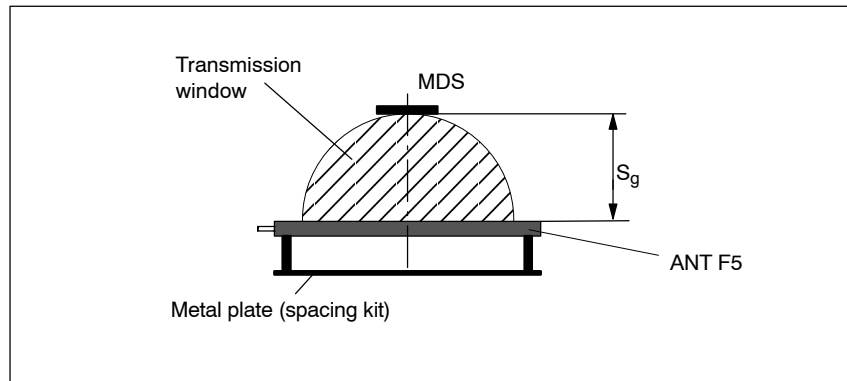

Figure 3-3 Working in static operation

Working in dynamic operation

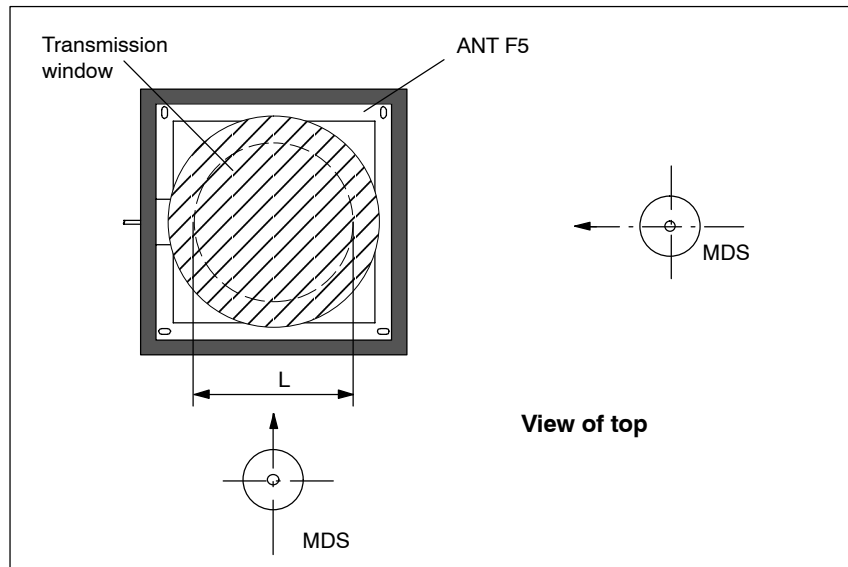

Figure 3-4 Working in dynamical operation

Width of the transmission window

The following approximation formula applies to practical applications:

$$B = 0.4 \cdot L$$

B: Width of the transmission window

L: Length of the transmission window

The width of the transmission window (B) is particularly important for the tolerance of mechanical tracking. When B is maintained, the formula can be used without restriction for the transmit period.

3.1.2 Transmit Period of the MDS

The transmit period is the time during which the MDS is located in the transmission window of an SLG/SLA. During this time, the SLG/SLA can exchange data with the MDS.

The formula used to calculate the transmit period is shown below.

$$t_V = \frac{L \cdot 0.8 [m]}{V_{MDS} [m/s]}$$

t_V : Transmit period of the MDS

L: Length of the transmission window

V_{MDS} : Speed of the data memory in dynamic operation

0.8: Constant factor. Compensates for temperature influences and production tolerances.

During static operation, the transmit period can be any length of time. The transmit period must last at least as long as necessary to conclude communication with the MDS.

During dynamic operation, the transmit period is determined by the system environment. The amount of data to be transferred must be adjusted to the transmit period or vice versa.

General formula:

$$t_V \geq t_K$$

t_V : Transmit period of the data memory in the field of the SLG/SLA

t_K : Communication time between MDS and ASM

3.1.3 Communication between ASM, SLG/SLA and MDS F4xx

Communication between ASM, SLG/SLA and MDS is asynchronous with a transmission speed of 19200 baud.

General formula:

$$t_K = K + t_{Byte} \cdot n$$

Calculation of the maximum amount of user data:

$$n_{max} = \frac{t_V - K}{t_{Byte}}$$

- t_K: Communication time between ASM, SLG/SLA and MDS
- t_V: Transmit period
- n: Amount of user data in bytes
- n_{max}: Maximum amount of user data in bytes during dynamic operation
- t_{byte}: Transmission time for 1 byte (cf. table 3-1)
- K: Constant. The constant represents an internal system time. It contains the time required for power buildup on the MDS and the time required for command transmission (cf. table 3-1).

Table 3-1 Constant time K and t_{Byte}

K [msec]	t _{Byte} [msec]	Operating Mode	
180	6	Read MDS	ASM with SLG
180	10	Write MDS	
180	5	Read MDS	ASM with SLA (ASM 854, 824, 850)
270	6	Write MDS	

This table applies to all commands. When a user command consists of several subcommands, the formula for t_K must be applied to each subcommand.

The t_K calculation applies to interference-free transmission. When transmission is briefly interrupted due to external interference, the ASM continues the command automatically.

Table 3-2 Transmission time of ID number MDS F1xx/MDS F4xx, starting at address 0

	Size ID No.	Read ID No. \triangle t _K [msec]
MDS F1xx	5 bytes	50 msec
MDS F4xx	4 bytes	60 msec

Table 3-3 Maximum transversal speed for reading the ID number

	V_{MDS} with SIM/SLG 82/SLA 81	V_{MDS} with SLA 82	V_{MDS} with SLG/SIM 80 with ANT F5
MDS F124	1.1 m/sec	2 m/sec	4.5 m/sec
MDS F125	1.1 m/sec	2 m/sec	4.5 m/sec
MDS F160	0.9 m/sec	1.6 m/sec	3.7 m/sec
MDS F415	0.9 m/sec	1.6 m/sec	3.7 m/sec

3.1.4 Communication between ASM and User Program

The time required for communication between ASM and user depends on the following factors.

- Cycle time and type of programmable controller
- Software used (FB 41, FB 47, FC 47, FB 240, FC 44, FC 45, FB 250)

Communication between the ASM 400 and the user can be divided into three steps.

- a) The user issues a command and starts it. When the FB is called the next time, the command is transferred to the ASM and is acknowledged by the ASM.
- b) The ASM executes the command with the MDS. The user or the FBs are in wait status. Data communication with the MDS starts as soon as an MDS enters the transmission window of the SLG/SLA. The MDS data are stored intermediately on the ASM and checked for correctness.
- c) Communication of the ASM with the MDS has been concluded. When the FB is called the next time, the read data or the results of a write command are transferred from the ASM to the user. The user receives a finished message.

See applicable documentation for the exact communication times between ASM and user.

3.1.5 Sample Calculation

The customer application

A conveyor system moves the pallets with the MDS at a maximum speed of $V_{MDS} = 1$ m/sec. The following MOBY F components were selected.

- ASM 400 (with FB 250)
- SLG 80 ANT F5
- MDS F415

Task:

- a) Physical specifications are to be provided to the constructor of the plant.
- b) The maximum number of bytes in dynamic operation is to be provided to the programmer.

For technical data of the components, see the tables in chapter 3.2 (“field data of MDS and SLG/SLA/SIM”).

Tolerance of the height allowance of the pallet

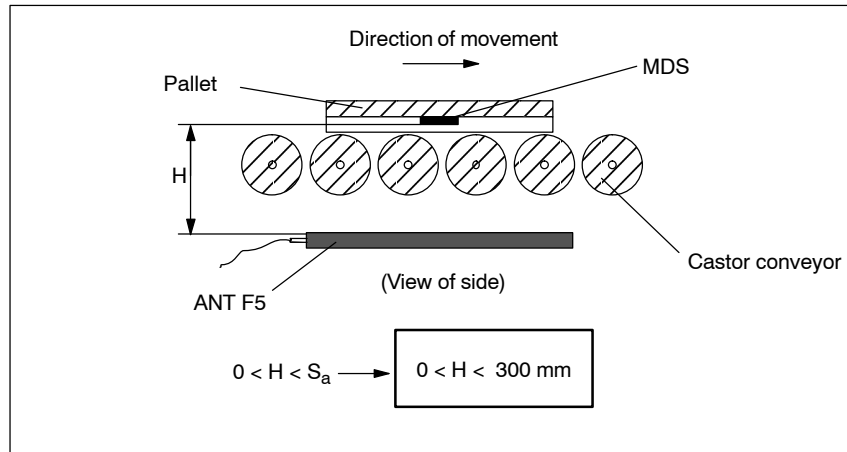

Figure 3-5 Tolerances of the side allowance of the pallet

Tolerances of the side allowance of the pallet

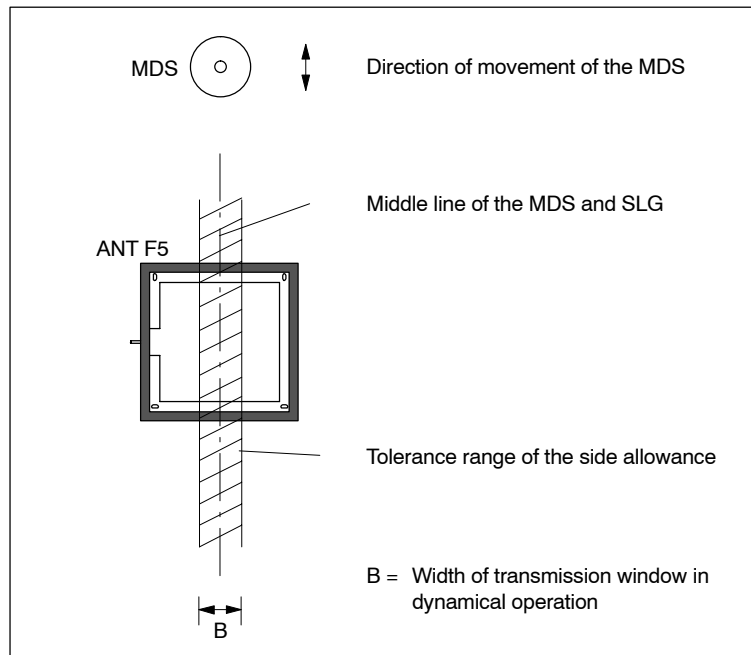

Figure 3-6 Tolerance of the side allowance of the pallet

Minimum distance between antennas

See table 3-6 for this value.

Minimum distance between MDS and MDS

See table 3-5 for this value.

Maximum number of bytes

$$t_v = \frac{L * 0.8}{V_{MDS}} = \frac{0.28 m * 0.8}{1 m/sec} = 0.224 \text{ sec} = 224 \text{ msec}$$

For normal operating mode, see table 3-1 for the values of K and t_{byte} .

Calculation of n_{max}

Read:

$$\frac{t_v - K}{t_{Byte}} = \frac{224 \text{ msec} - 180 \text{ msec}}{6 \text{ msec}} = 7.33 \Rightarrow n_{max} = 7 \text{ bytes}$$

Write:

$$\frac{t_v - K}{t_{Byte}} = \frac{224 \text{ msec} - 180 \text{ msec}}{10 \text{ msec}} = 4.40 \Rightarrow n_{max} = 4 \text{ bytes}$$

Up to 11 bytes can be read or 4 bytes can be written when the MDS passes by.

3.2 Field Data of MDS and SLG/SLA/SIM

The following table shows the field data of all MOBY F MDS and SLG/SLA/SIM components. This information makes it particularly easy to select an MDS and an SLG/SLA/SIM.

All technical data are typical data and are valid for an ambient room temperature of 0° to +50° C, and a voltage supply of 22 V to 27 V DC. **Tolerances of ± 20% are permitted due to manufacturing and temperature factors.**

Additional tolerances apply to the field data when the total voltage range of 20 V to 30 V DC is utilized on the SLG/SLA/SIM and/or the total temperature range is utilized on the MDS and SLG/SLA/SIM.

Note

To ensure optimal field data even in metallic surroundings, the ANT F5 is calibrated at the plant to a distance of 100 mm to metal.

Table 3-4 Field data of all MDSs and SLGs/SLAs/SIMs (ANT F5 with 100-mm distance to metal)

MDS SLG/SIM	MDS F124	MDS F125	MDF F160	MDS F415
Length of the transmission window in mm (L)				
SLG/SIM 80 ANT F5	280	280	230	280
SLG/SIM 82	∅ 70	∅ 70	∅ 40	∅ 70
SLA 81	∅ 70	∅ 70	∅ 40	∅ 70
SLA 82	∅ 120	∅ 120	∅ 120	∅ 120
Width of the transmission window in mm (W)				
SLG/SIM 80 ANT F5	110	110	92	110
SLG/SIM 82	30	30	16	30
SLA 81	30	30	16	30
SLA 82	48	48	48	48
Working distance in mm (S_a)				
SLG/SIM 80 ANT F5	0 to 240	0 to 380	0 to 140	0 to 300
SLG/SIM 82	0 to 65	0 to 110	0 to 60	15 to 90
SLA 81	0 to 65	0 to 110	0 to 60	15 to 90
SLA 82	0 to 140	0 to 180	0 to 90	20 to 150

Table 3-4 Field data of all MDSs and SLGs/SLAs/SIMs (ANT F5 with 100-mm distance to metal)

MDS SLG/SIM	MDS F124	MDS F125	MDF F160	MDS F415
Limit distance in mm (S_g)				
SLG/SIM 80 ANT F5	280	420	160	340
SLG/SIM 82	80	140	70	110
SLA 81	80	140	70	110
SLA 82	160	200	120	180

Note

If the range on the SLG/SLA/SIM is not sufficient ...

- Check power pack/switching power supply for interference. See chapters 3.5 and 3.7.
- Monitor or other source of interference in the vicinity. See chapter 3.5.
- Check metallic surroundings. See chapter 3.4.

Table 3-5 Minimum distance from MDS to MDS

	MDS F124	MDS F125	MDS F160	MDS F415
SLG/SIM 80 with ANT F5	≥ 1 m	≥ 1 m	≥ 1 m	≥ 1 m ¹
SLG/SIM 82	≥ 0.3 m	≥ 0.4 m	≥ 0.3 m	≥ 1 m
SLA 81	≥ 0.3 m	≥ 0.4 m	≥ 0.3 m	≥ 1 m
SLA 82	≥ 0.6 m	≥ 0.8 m	≥ 0.6 m	≥ 1 m

¹ The minimum distance can be reduced for SIM 80 ANT F5 in multi-tag operation. The MDSs may be located next to each other, but overlapping is not permitted.

Table 3-6 Minimum distance from antenna to antenna with MDS 4xx (r/w)

	SLG/ SIM 80 ANT F5	SLG/ SIM 82	SLA 81	SLA 82
SLG/SIM 80 with ANT F5	≥ 5 m	≥ 2 m	≥ 2 m	≥ 3.5 m
SLG/SIM 82	≥ 2 m	≥ 1.2 m	≥ 1.2 m	≥ 1.6 m
SLA 81	≥ 2 m	≥ 1.2 m	≥ 1.2 m	≥ 1.6 m
SLA 82	≥ 3.5 m	≥ 1.6 m	≥ 1.6 m	≥ 2.5 m

Table 3-7 Minimum distance from antenna to antenna with MDS 1xx (r/o)

	SLG/SIM 80 ANT F5	SLG/SIM 82	SLA 81	SLA 82
SLG/SIM 80 with ANT F5	≥ 1.5 m	≥ 1 m	≥ 1 m	≥ 1.2 m
SLG/SIM 82	≥ 1 m	≥ 0.4 m	≥ 0.4 m	≥ 0.8 m
SLA 81	≥ 1 m	≥ 0.4 m	≥ 0.4 m	≥ 0.8 m
SLA 82	≥ 1.2 m	≥ 0.8 m	≥ 0.8 m	≥ 1.2 m

Note

The values listed in tables 3-6 and 3-7 must be adhered to. Non-adherence would affect the inductive fields. Data transmission time would increase to an unknown value, or a command would be terminated with errors. A test is recommended for critical applications.

3.3 Relationship of Speed to Amount of Data

The curves shown below will simplify preliminary selection of the MDS and SLG MOBY F components for dynamic use.

The table in chapter 3.1.3 was used to calculate the curves. The curves are valid for operation within the transmission window (L).

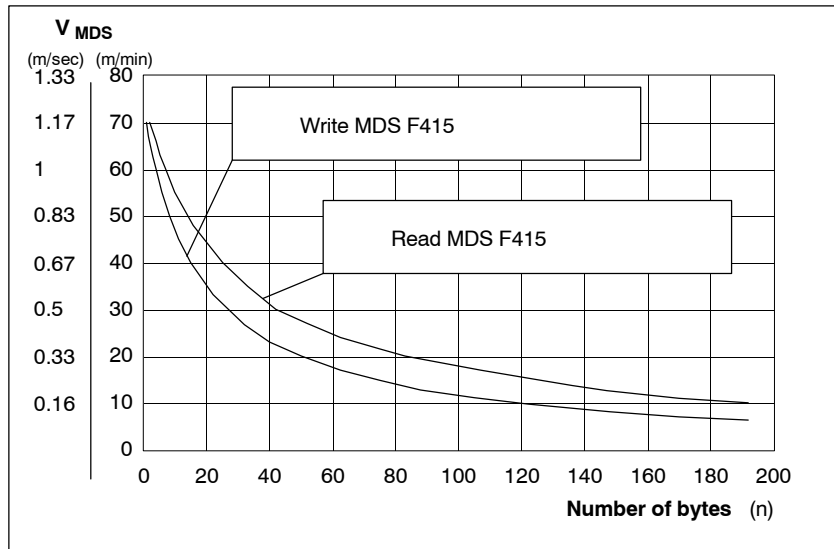

Figure 3-7 SLG 80 ANT F5 with MDS F415

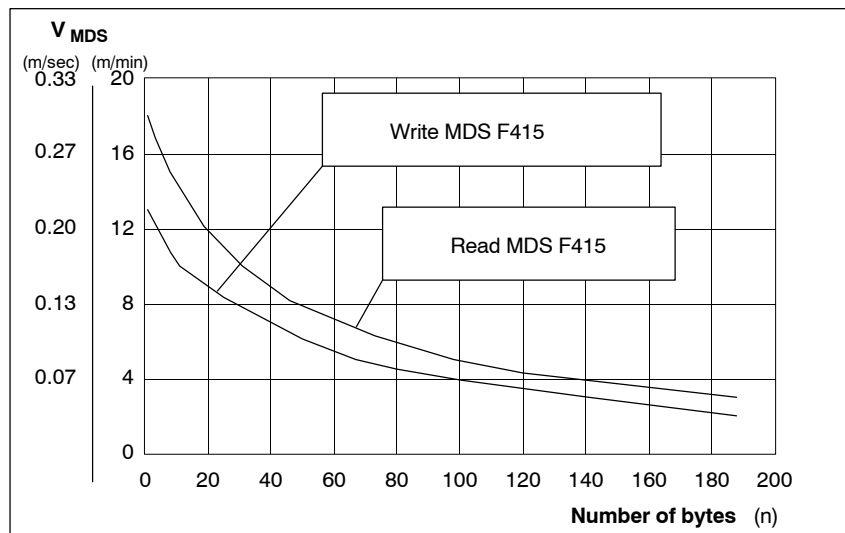

Figure 3-8 SLA 81 with MDS F415

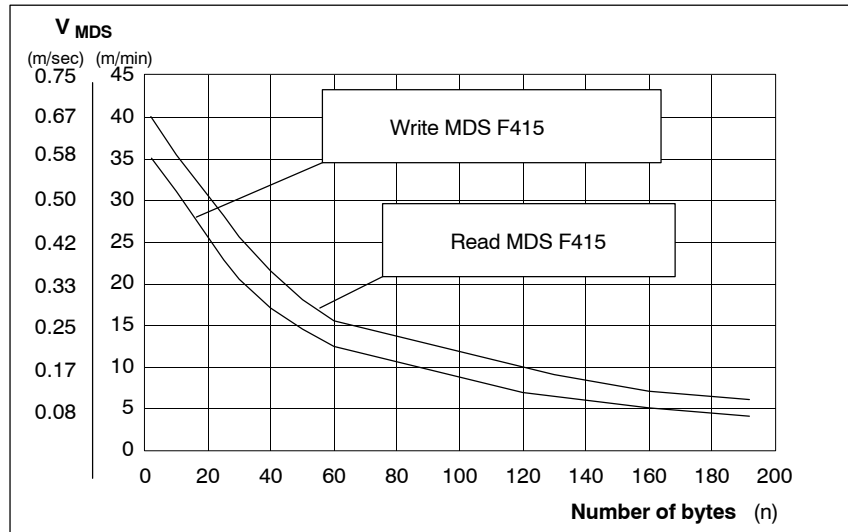

Figure 3-9 SLA 82 with MDS F415

Note

For transversal speed for reading the ID number, see table 3-3.

3.4 Installation Guidelines

The MDS and SLG/SLA/SIM are inductive devices. All types of metal (i.e., particularly iron and ferromagnetic materials) in the vicinity of these devices affect their operation. To ensure that the field data described in chapter 3.2 retain their validity, several points must be adhered to with respect to configuration and installation.

- Minimum distance between two antennas
(See tables 3-6/3-7 or chapter 5.)
- Minimum distance to two adjacent data memories
(See table 3-5 and chapter 4.)
- Metal-free space with flush installation of SLG/SLA/SIM ANT F5 in metal
- Installation of several antennas on metal frame or support

The next few chapters will discuss how the identification system is affected when mounted in a metallic environment.

3.4.1 Metal-Free Space

Metal-free space for MDS

Direct installation of the MDS on metal or flush in metal is **not permitted**. The MDS loses all its functions if mounted directly on metal.

For the minimum distance of the MDS to metal, see the applicable paragraphs on metal-free space in chapter 4.

Metal-free space for SLG/SIM

When installing the SLG/SIM, remember that metal in the vicinity of the antennas can affect field data. Typical distances to metal are indicated in the sections on metal-free space in chapters 5 and 6.8.

ANT F5

The ANT F5 must be insulated (i.e., direct installation on metal is **not permitted**).

The maximum field data (no interference = 100%) apply when antenna ANT F5 is mounted 100 mm from metal.

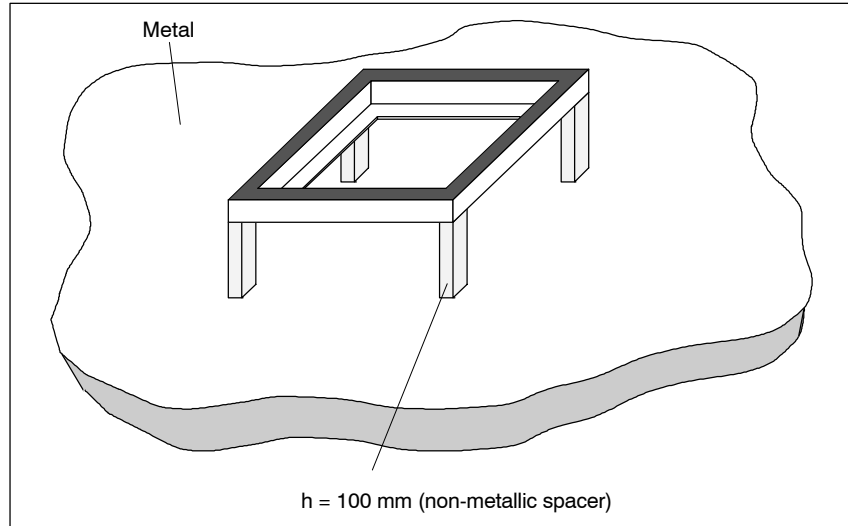

Figure 3-10 Isolated mounting of ANT F5 on metal

**SLG 82/SIM 82/
SLA 81**

The SLA 81 antenna can be mounted in metal as shown in the following drawing.

Remember to consider possible reduction of the field data (see chap. 3.4.2).

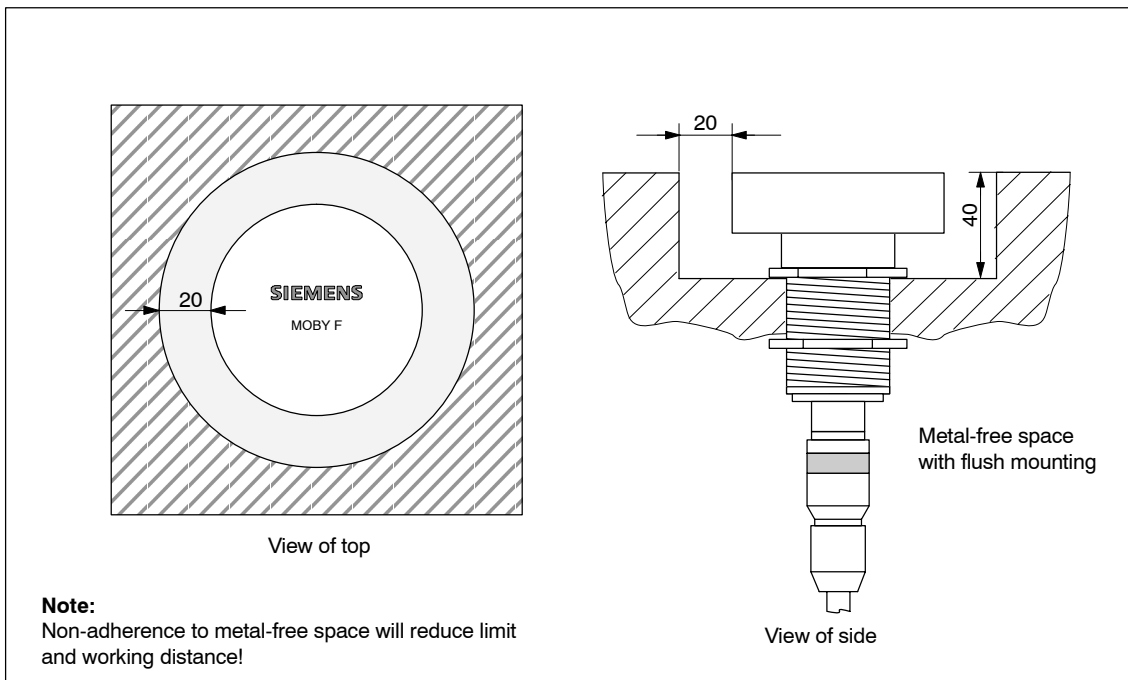

Figure 3-11 SLA 81 mounted in metal

SLA 82

The SLA 82 can be mounted flush in metal. Remember that the field data may be reduced (see chap. 3.4.2).

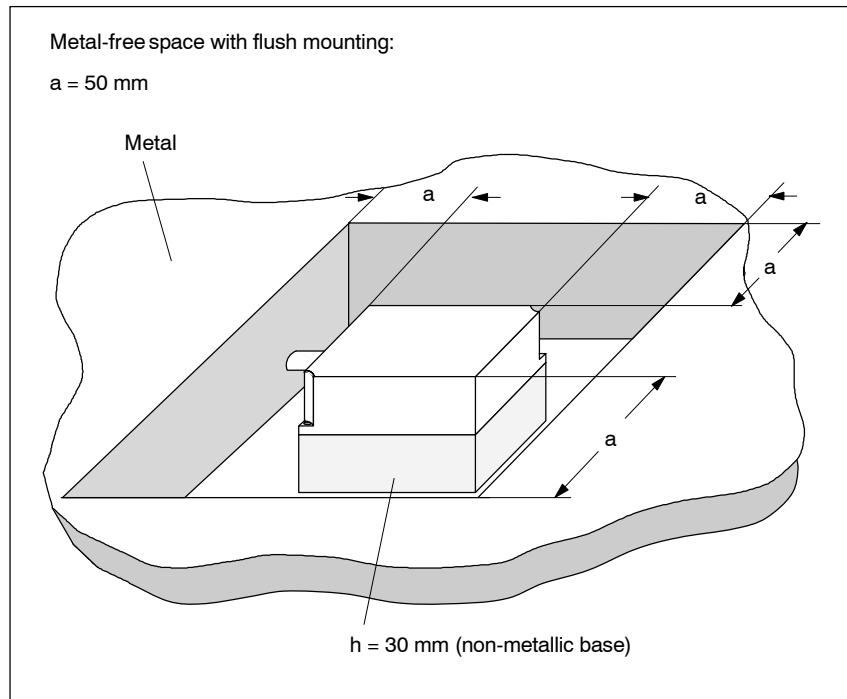

Figure 3-12 Flush mounting in metal: SLA 82

3.4.2 Effects on the Transmission Window

The following general points must be adhered to when installing MOBY F components.

- The MDS and antennas may not be mounted directly on metal.
- Flush installation of the components in metal reduces the field data.
- Inside the transmission window, do not allow metal rails or similar to cut across the transmission field. The metal rail would affect the field data.
- **A test is recommended when critical applications are involved.**
- To ensure optimal field data even in metallic environments, the ANT F5 is calibrated at the plant to a distance of 100 mm to metal. See table 3-8.

This chapter uses tables and graphs to illustrate the effects of metal on the field data (i.e., S_g , S_a , L and W). The values in the tables describe field data reduction in percentages (i.e., no effect: 100%).

MDS and SLG 80/SIM 80 with ANT F5

Table 3-8 Reduction of field data in %:
MDS and SLG/SIM with ANT F5 (See figures 3-13/3-14.)

MDS \ SLG/SIM 80	ANT F5 without Metal	ANT F5 on Metal 65-mm Distance	ANT F5 on Metal 100-mm Distance	ANT F5 Flush in Metal; Metal-Free 100-mm Distance Around and 100-mm Depth
MDS F124				
MDS without metal	75	80	100	100
MDS on metal, 30-mm interval	–	60	75	70
MDS on metal, 50-mm interval	70 ¹	65	90	80
MDS F125				
MDS without metal	85	80	100	90
MDS on metal, 30-mm interval	55	60	75	70
MDS on metal, 50-mm interval	70	65	80	75
MDS F160				
MDS without metal	–	65	100	100
MDS on metal 20-mm interval	–	65	75	75

Table 3-8 Reduction of field data in %:
MDS and SLG/SIM with ANT F5 (See figures 3-13/3-14.)

MDS \ SLG/SIM 80	ANT F5 without Metal	ANT F5 on Metal 65-mm Distance	ANT F5 on Metal 100-mm Distance	ANT F5 Flush in Metal; Metal-Free 100-mm Distance Around and 100-mm Depth
MDS F415				
MDS without metal	90	80	100	90
MDS on metal, 30-mm interval	–	60	75	70
MDS on metal, 50-mm interval	70	65	80	75

1 In this configuration, the MDS F124 must be installed with a distance of ≥ 150 mm to metal. Underranging this value may cause transmission gaps in the field.

**MDS and
SLG 82/SIM 82/
SLA 81**

Table 3-9 Reduction of the field data by mounting in metal (in %):
MDS and SLG 82/SIM 82/SLA 81

MDS \ SLG/SIM 82 and SLA 81	No Metal	Mounted Flush in Metal; Metal-Free 20-mm Distance Around and 40-mm Depth
MDS F124		
MDS without metal	100	65
MDS on metal. Space of 20 mm	90	60
MDS mounted flush in metal. Space of 20 mm. 20 mm around outside.	75	55
MDS F125		
MDS without metal	100	55
MDS on metal. Space of 20 mm	85	50
MDS mounted flush in metal. Space of 20 mm. 20 mm around outside.	70	45
MDS F160		
MDS without metal	100	65
MDS on metal, space of 20 mm	85	60
MDS F415		
MDS without metal	100	60
MDS on metal. Space of 20 mm	85	55
MDS mounted flush in metal. Space of 20 mm. 20 mm around outside.	70	50

MDS with SLA 82

Table 3-10 Reduction of the field data by mounting in metal (in %):
MDS with SLA 82

MDS \ SLA 82	Without Metal	SLA 82 on Metal, Distance: 30 mm	Mounted Flush in Metal; Metal-Free 50-mm Distance Around and 30-mm Depth
MDS F124			
MDS without metal	100	75	70
MDS on metal, distance of 20 mm	70	55	50
MDS mounted flush in metal, distance of 20 mm, distance around of 30 mm	55	45	40
MDS F125			
MDS without metal	100	80	70
MDS on metal, distance of 20 mm	75	60	50
MDS mounted flush in metal, distance of 20 mm, distance around of 30 mm	60	50	40
MDS F160			
MDS without metal	100	70	70
MDS on metal, distance of 20 mm	60	55	50
MDS F415			
MDS without metal	100	75	70
MDS on metal, distance of 20 mm	80	55	50
MDS mounted flush in metal, distance of 20 mm, distance around of 30 mm	60	40	40

The following figures illustrate the effects on the transmission window using the SLG 80 ANT F5 with the MDS F415 as an example.

The percentages indicate the reduction of field data as related to the ANT F5 and the MDS in a metallic environment. 100% means no effect on the field data.

MDS in metal-free environment

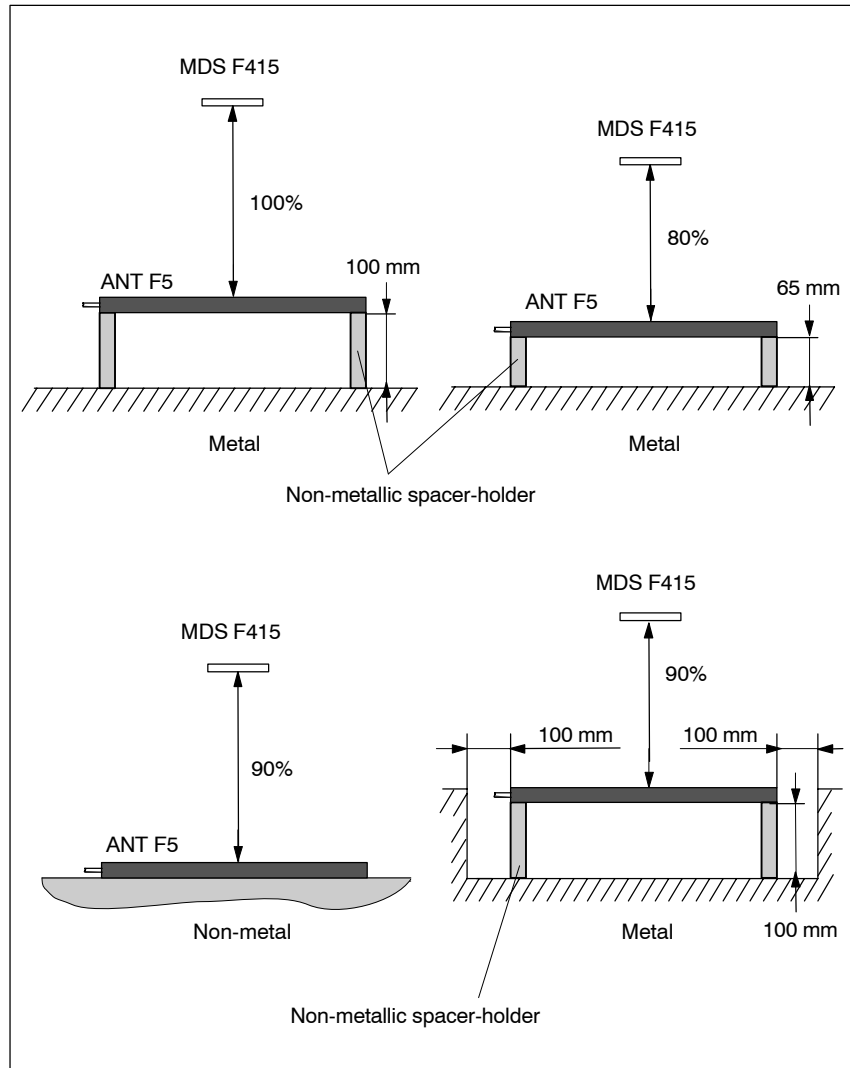

Figure 3-13 MDS in metal-free environment

MDS in metallic environment

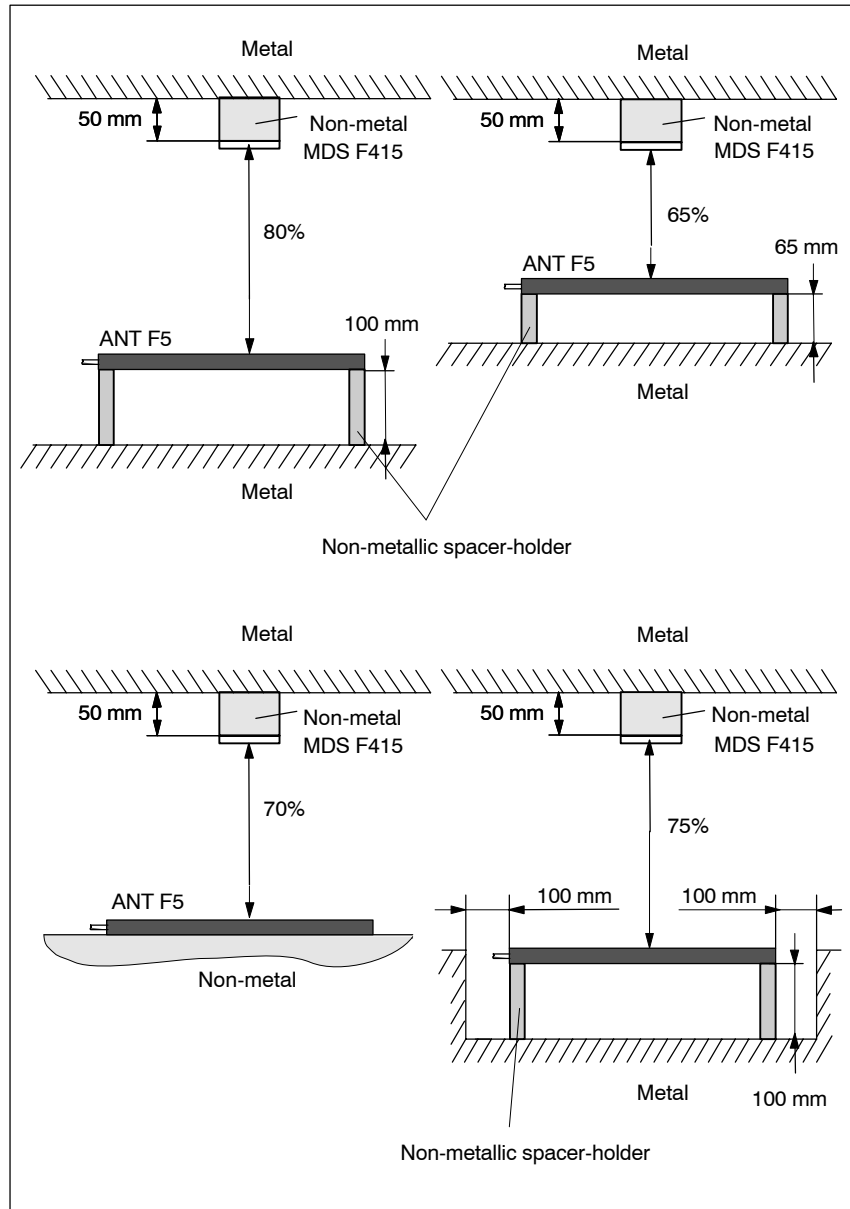

Figure 3-14 MDS in metallic environment

3.4.3 Reduction of Metallic Effects

Interfering metal supports

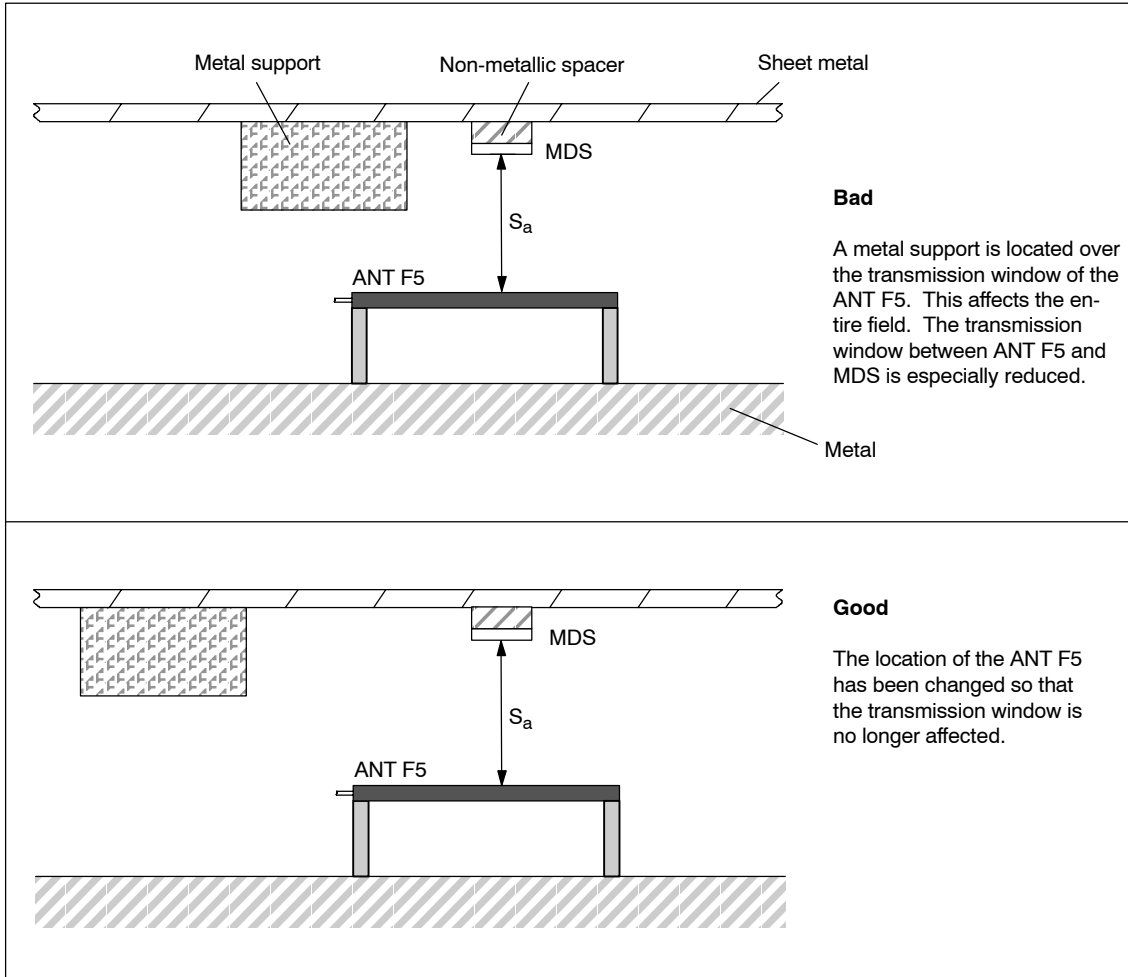

Figure 3-15 Interfering metal support

Flush installation

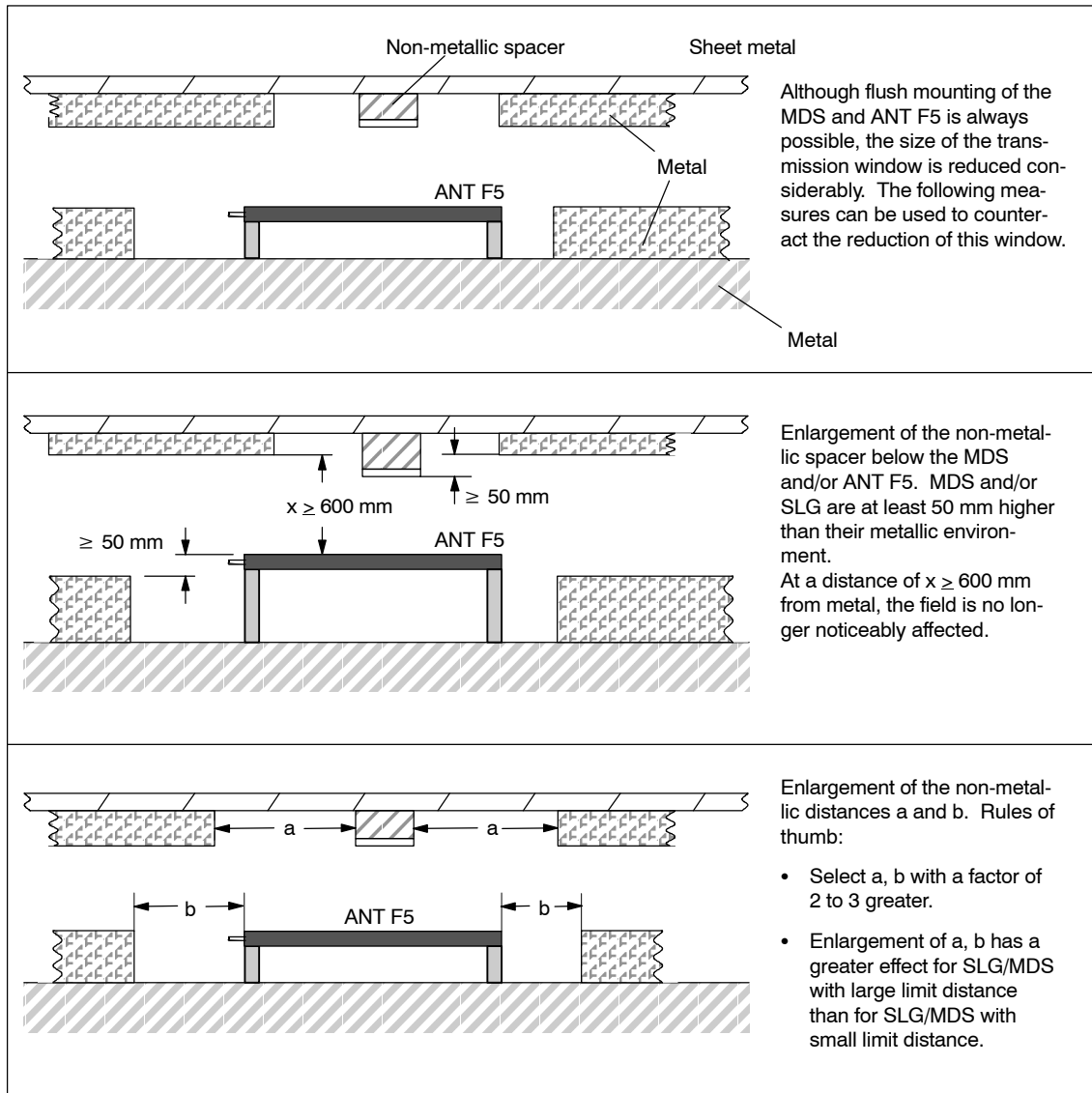

Figure 3-16 Flush installation

Installation of several ANT F5s on metal frame or support

Every ANT F5 which is mounted on metal with insulation couples part of the field on the metal support. If minimum distance D and metal-free spaces a , b are adhered to, there are usually no counter effects. However, effects are possible if the location of an iron frame is particularly unfavorable. This increases data transmission times and creates sporadic error messages on the interface.

What must be done?

- a) Enlargement of distance D between the two antennas

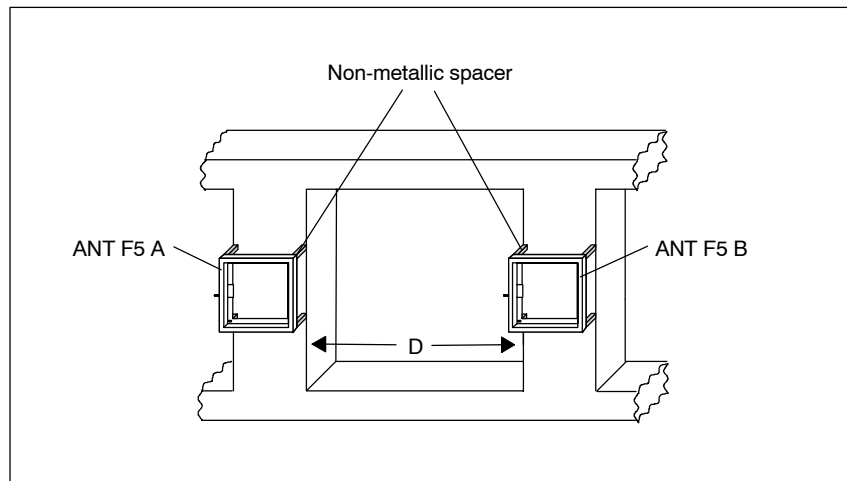

- b) Insertion of a non-metallic spacer (thickness of 100 millimeters) between ANT F5 and iron frame. This significantly reduces the parasitic interference of the field on the support.

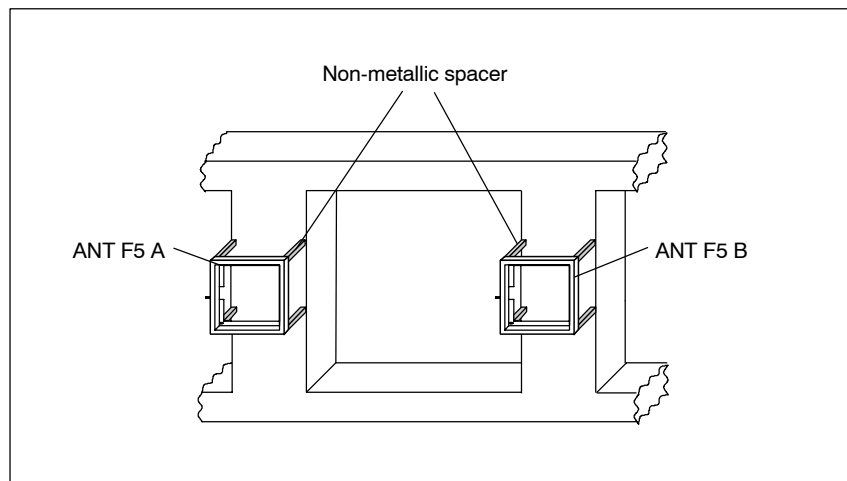

3.4.4 Chemical Resistance of the Mobile Data Memories

The MDSs F124/F125/F415 are resistant to the substances listed in the following table.

Table 3-11 Chemical resistance of data memories made of fiber glass reinforced epoxy resin (MDS F124/F125/F415)

	Concentration	20° C	40° C	60° C
Formic acid	50%	■		
	100%	●		
Ammonia, gaseous		■		
Ammonia, liquid, anhydrous		□		
Ammonium hydroxide	10%	■		
Ethanol			■	■
Ethylene glycol				■
Gasoline, free of aromatic compounds		■		
Gasoline, unstripped		■		
Bezoates (Na-, Ca- and similar)			■	
Bezoic acid		■		
Benzine		■		
Borax				■
Boric acid		■		
Bromine, liquid		□		
Butadiene (1, 3-)		■		
Butane, gaseous		■		
Butanol		□		
Butyric acid	100%	●		
Carbonates (ammonia-, Na- and sim.)				■
Chlorine, liquid		□		
Chlorine, gaseous, dry	100%	□		
Chlorobenzene		■		
Chloride (ammonia-, Na- and similar)				■
Chloroform		□		
Chlorophyll		■		
Chlorine water (saturated solution)		●		
Chromates (K-, Na- and similar)	Up to 50%		■	
Chromic acid	Up to 30%	□		
Chromic sulfuric acid		□		
Citrates (ammonia-, Na- and similar)				■
“Lemon acid”		■		
Cyanamide		■		
Cyanides (K-, Na- and similar)				■
Cyclohexanol		■		
Cyclohexanone		●		
Diethylene glycol				■
Bichromates (K- and Na-)		■		
Dioxan		□		
Developer			■	
Acetic acid	100%	●		
Fixing bath			■	
Fluorides (ammonia-, K-, Na- and sim.)			■	
Hydrofluoric acid	Up to 40%	■		
Formaldehyde	50%	■		
Gluconic acid		■		

Table 3-11 Chemical resistance of data memories made of fiber glass reinforced epoxy resin (MDS F124/F125/F415)

	Concentration	20° C	40° C	60° C
Glycerin				■
Glycocoll				■
Urine		■		
Uric acid		■		
Hexafluoro silicate (ammonia-, Na- and similar)				■
Hydroxides (alkaline earth metal-)				■
Iodides (K-, Na- and similar)				■
Silicic acid				■
Methanol	100%		■	
Methylene chloride		□		
Lactic acid	100%	●		
Mineral oils			■	
Nitrates (ammonia-, K- and similar)				■
Nitroglycerin		□		
Oxalic acid		■		
Perchlorates (K-)				■
Phenol	1%	■		
Phosphates (ammonia-, Na- and similar)				■
Phosphoric acid	50%			■
	85%	■		
Propyl alcohol		■		
Nitric acid	25%	□		
Hydrochloric acid	10%	□		
Brine				□
Sulfur dioxide	100%	●		
Carbon bisulphide, 100%		□		
Sulphuric acid	40%	□		
Sulphurous acid		●		
Soap solution				■
Sulfates (ammonia-, Na- and similar)				■
Sulfites (ammonia-, Na- and similar)				□
Tar, free of aromatic compounds				■
Turpentine		■		
Trichlorethylene		□		
Tartaric acid		■		

Explanation of the symbols

- Resistant
- Somewhat resistant
- Not resistant

3.5 EMC Guidelines

3.5.1 Foreword

The EMC guidelines contain the following information.

- Why are the EMC guidelines necessary?
- What interference affects the controller from the outside?
- How can interference be prevented?
- How can interference be corrected?
- Which standards apply to the EMC guidelines?
- Examples of an interference-suppressed system setup

The description is directed to “qualified personnel”.

- Configuration engineers and planners who plan system configuration with the MOBY modules and who must adhere to the required guidelines
- Skilled personnel and service engineers who install the connection cables based on this description or who can correct deficiencies in this area when a malfunction occurs.



Warning

Non-adherence to especially highlighted notes can cause dangerous states in the system or destroy either single components or the entire system.

3.5.2 General

The continuously growing use of electrical and electronic devices brings with it the following characteristics.

- Greater concentration of components
- Increasing capacity of power electronics
- Rising switching speeds
- Lower current consumption of the components

The higher the degree of automation, the greater the danger that devices will interfere with one another.

- Electromagnetic compatibility (i.e., EMC) is the ability of a piece of electrical or electronic equipment to function correctly in an electromagnetic environment without interfering with or adversely affecting its surroundings within certain limits.

EMC can be divided into three areas.

- Intrinsic interference immunity
Resistance to internal (i.e., own) electrical interference
- Free interference immunity
Resistance to external electromagnetic interference
- Degree of interference emission
Interference emission and effects of the electrical environment

All three areas are included in the test of an electrical device.

The MOBY modules are tested for adherence to the limit values contained in the CE and BAPT guidelines. Since MOBY modules are only one of many components in a total system and the combination of various components may also create sources of interference, certain guidelines must be adhered to when setting up a system.

EMC measures usually consist of an entire package of measures all of which must be taken in order to obtain an interference-immune system.

Note

- The system provider is responsible for adherence to the EMC guidelines, while the user is responsible for the interference suppression of the complete system.
 - All measures taken while the system is being set up will eliminate the need for expensive modifications and removal of interference sources later.
 - Although the regulations of specific countries must also be adhered to, this information is not covered in the documentation.
-

3.5.3 Spreading of Interference

Three components are required so that interference can affect a system.

- Source of interference
- Coupling path
- Potentially susceptible equipment

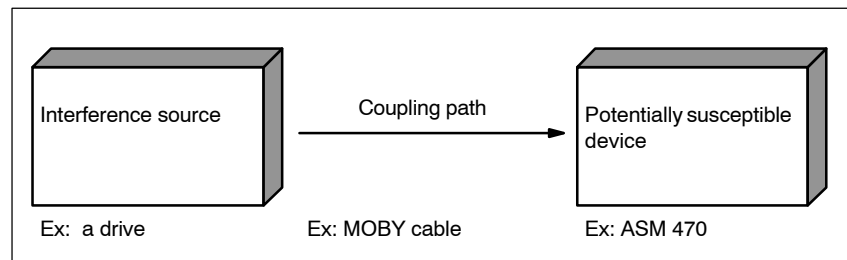

Figure 3-17 Spreading of interference

If one of these components is missing (e.g., the coupling path between the source of the interference and the potentially susceptible device), the susceptible device will not be affected even when strong interference is being emitted.

The EMC measures affect all three components to prevent any malfunctions caused by interference. When a system is set up, the provider must take all possible measure to prevent the creation of sources of interference.

- Only equipment which meets limit value class A of VDE 0871 may be used in a system.
- All interference caused by devices must be suppressed. This includes all coils and windings.
- The layout of the cabinet must be such that reciprocal interference of the individual components is avoided or kept as low as possible.
- Measures must be taken to eliminate interference from external sources.

The next few chapters provide information and tips on how to set up a system.

Sources of interference

It is necessary to be familiar with the most frequent sources of interference in order to achieve a high degree of electromagnetic compatibility (i.e., a very low degree of interference in the environment) in a system. These sources of interference must be eliminated by taking appropriate measures.

Table 3-12 Interference sources: Origin and effects

Interference Source	Interference Origin	Effect on Potentially Susceptible Equipment
Contactors, electronic valves	Contacts Coils	Power network malfunctions Magnetic field
Electric motor	Collector Winding	Electrical field Magnetic field
Electric welding device	Contacts Transformer	Electrical field Magnetic field, power network malfunction, equalizing currents
Power pack, switched-mode	Circuit	Electrical and magnetic field, power network malfunction
High-frequency devices	Circuit	Electromagnetic field
Sender (e.g., industrial radios)	Antenna	Electromagnetic field
Difference in grounding or reference potential	Voltage difference	Equalizing currents
Operator	Static charging	Electrical discharging currents, electrical field
High-voltage current cable	Current flow	Electrical and magnetic field, power network malfunction
High-voltage cable	Voltage difference	Electrical field
Monitors	Circuit	Electromagnetic field
Defective neon lamps	Starter	Power network malfunction
Energy-saver lamps	Circuit	Electromagnetic field
Computer, PC	Circuit	Electromagnetic field

Coupling paths

A coupling path is required before interference generated by the source can take effect. There are four kinds of interference coupling.

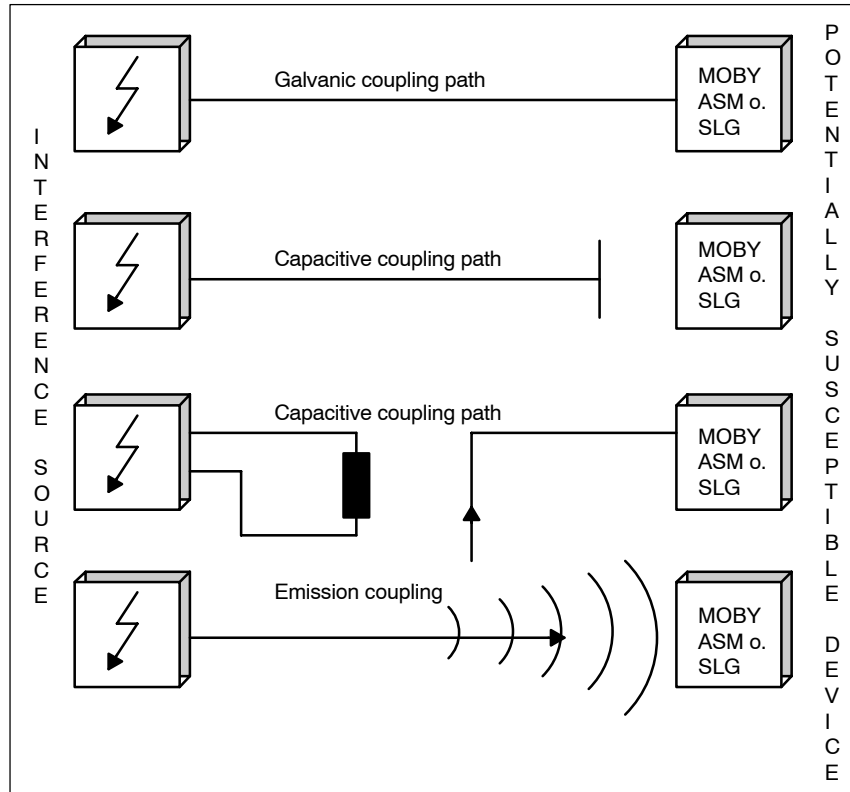

Figure 3-18 The four kinds of interference coupling

When MOBY modules are used, various components of the total system can act as coupling paths.

Table 3-13 Causes of coupling paths

Coupling Path	Cause
Cables and lines	Incorrect or unfavorable installation
	Missing or incorrectly connected shields
	Cables spaced unfavorably
Switching cabinet or SIMATIC housing	Missing or incorrectly wired equalizing line
	Missing or incorrect grounding
	Cables spaced unfavorably
	Modules not installed securely
	Poor cabinet layout

3.5.4 The FFT Command

Features for the user The FFT command filters EMC interference from the environment. This means that you can still use the MOBY F in environments where other identification systems fail.

Typical example:

Computer monitors or switching power packs cause such interference in the environment that a MOBY F SLG may no longer be able to function fully when in the vicinity of these devices. The maximum read-access distance may be reduced to 0.

Use of the FFT command restores the maximum read-access distance again.

Use The FFT command (Fast Fourier Transformation) is a command to the processor of the read/write device (SLG). The FFT command causes the processor of the SLG to screen out interference signals in the area around the SLG.

The FFT command should be used under the following conditions.

- When the interference environment around the SLG changes
- After the SLG is turned on
- When processing of the MDS commands takes longer than stated in the documentation
- In critical applications, the FFT command can be started prior to every MDS command.
- The SLG automatically performs an FFT once after being turned on.

The FFT command may not be used under the following conditions.

- When a fixed code MDS (MDS 1xx) is located near an SLG

Processing time The FFT command requires a processing time of approx. 110 msec.

Execution of the command The FFT command is started by the user with a special command. Execution of the command varies depending on the interface. The next few pages describe how the FFT command is handled on the different interfaces.

FFT command for FB 250/ASM 400 The FFT command is started with the special command with the subcode 0005.

Command	Code	Length	Subcode	Data (DATDB)
FFT command	04	01	0005	1st data byte 01 = FFT command

FFT command with ASM 410

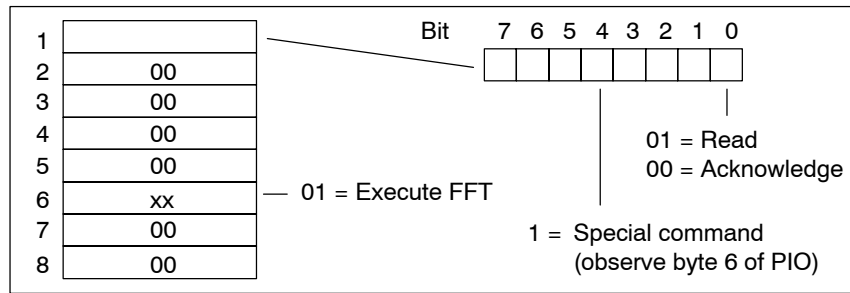

FFT command with FC 44, FB 240/ASM 450

Status command:
The status command executes an FFT command on the ASM in addition to the status scan. The MOBY F must have been parameterized beforehand.
The command is available with both the FB/FC and the user interface.

FFT command with FC 45/ASM 452

The FFT command is performed with the “antenna on/off” command and sub_command = 09.

FFT command with FC 47, FB 47/ASM 470

System command:
The INIT command is usually redefined into a system command. This ensures compatibility at lower levels.

Parameterizing the MOBY modes

Before the FFT command can be used, one of the MOBY F modes must have already been set. The following table shows the parameterization for the different MOBY interfaces.

Table 3-14 Parameterization of the MOBY F operating modes for the FFT command

Operating Mode	ASM 400	ASM 410	ASM 450		ASM 470	
	FB 250		FC 44/ FB 240	User interface (opt. 1)	FC 47/ FB 47	User interface (byte 3)
MOBY F MDS F1xx ³	91 ¹	91 ² (byte 5 in PIO)	5	A	5	A
MOBY F MDS F4xx	92 ¹	92 ²	6	B	6	B
MOBY F MDS F2xx	93 ¹	93 ²	7	C	7	C

- 1 The subcode for this parameterization is 0004.
- 2 The presence check must be turned off before the MOBY F is turned on. The presence (ANW) check can be turned on at the same time as the MOBY F.
- 3 The FFT command is not permitted with the MDS F1xx (is rejected with error 0F).

Note

The FFT command is only available with SLG 80 ANT F5 and SIM 80 ANT F5.

3.5.5 Cabinet Layout

User influence on the configuration of an interference-immune system includes the cabinet layout, cable installation, grounding connections and correct shielding of lines.

Note

For notes on correct cabinet layout in accordance with EMC guidelines, see the layout guidelines of the SIMATIC controller.

Shielding via housing

Metal housings for potentially susceptible equipment can be used to keep out magnetic and electrical fields and electromagnetic waves. The better the induced interference current can flow, the greater the spontaneous weakening of the field of interference. All sheet metal on the housings or sheet metal in the cabinet must be well connected together (i.e., with a high degree of conductivity).

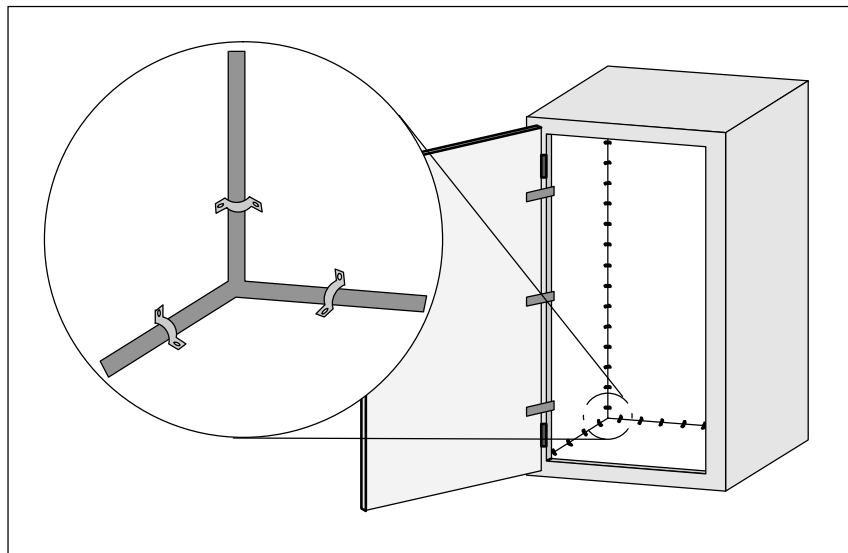

Figure 3-19 Shielding via housing

When the sheet metal parts of switching cabinets are insulated against each other, a high-frequency conductive connection with the ribbon cables and high-frequency terminals or HF conductive paste can be created. The greater the connection surface, the better the high-frequency conductive capacity. This cannot be achieved by connection with simple wires.

Avoiding interference via optimal layout

Good interference diversion is achieved by installing SIMATIC controllers on conductive mounting plates (unpainted). When setting up the switching cabinet, interference can be easily avoided by adhering to guidelines. Power components (e.g., transformers, drives and load power supplies) should be installed separately (i.e., separated by space) from the controller components (e.g., relay controllers and SIMATIC S5).

The following basic principles apply.

1. The effect of interference decreases the greater the distance between interference source and potentially susceptible equipment.
2. Interference is further reduced by installing shielding plates.
3. Load lines and high-voltage current cables must be installed separately from the signal lines at a distance of at least 10 cm.

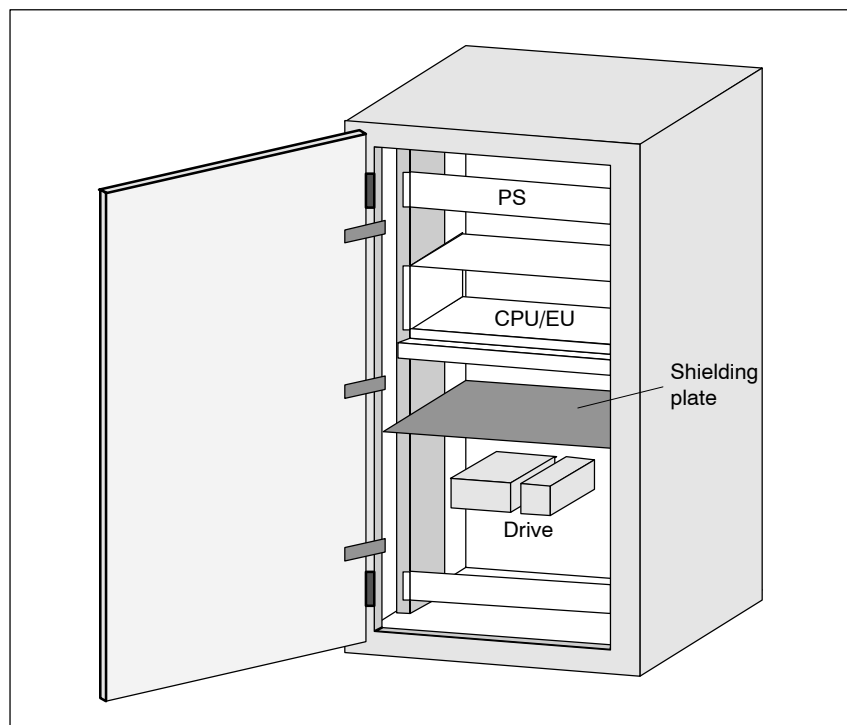

Figure 3-20 Avoidance of interference via optimal layout

Filtering the supply voltage

External interference from the power network can be avoided by installing power network filters. In addition to correct dimensioning, proper installation is very important. It is imperative that the power network filter be installed directly at the entrance to the cabinet. Interference currents are filtered out early at the entrance and not conducted through the cabinet.

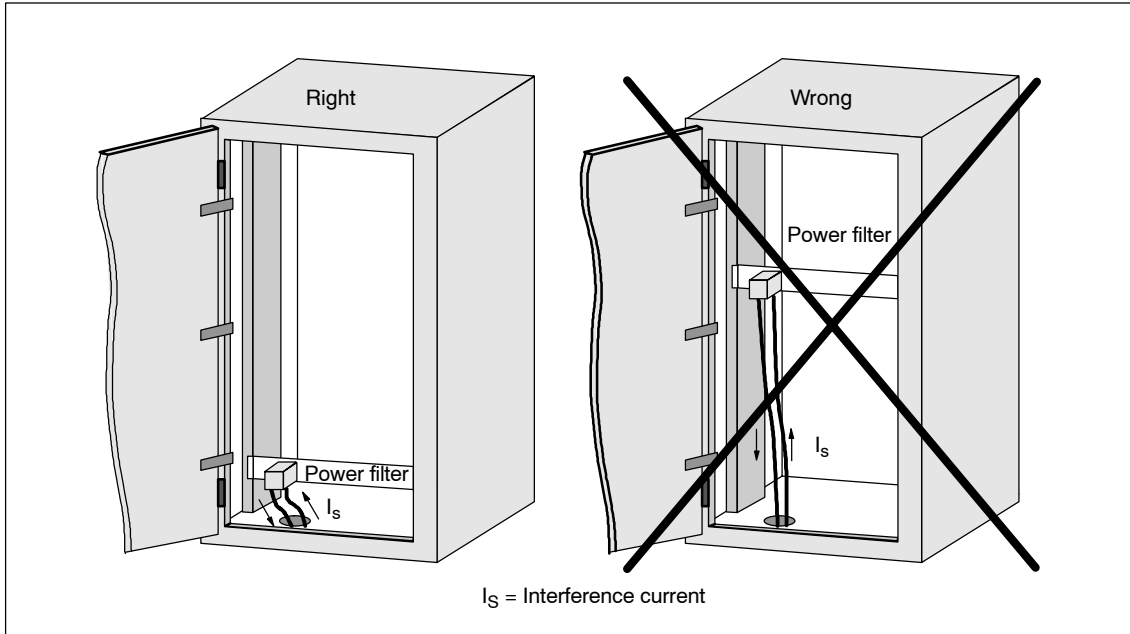

Figure 3-21 Filtering the supply voltage

3.5.6 Avoiding Interference Sources

Sources of interference in a system must be avoided so that a higher degree of interference immunity can be achieved. All circuited inductivities are a frequent cause of interference in a system.

Interference suppression of inductivities

Since relays, contactors and so on generate interference voltages, this interference must be suppressed with one of the following circuits.

When the coil is switched, up to 800 V can be created on 24 V coils even with small relays. Several kV can be created on 220 V coils. By using free-wheeling diodes or RC circuitry, the interference voltage is prevented and, with it, the inductive interference in the lines parallel to the coil lines.

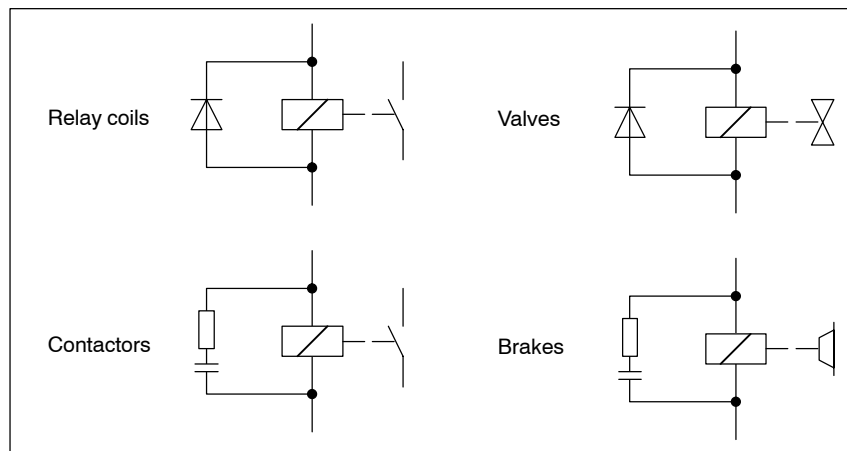

Figure 3-22 Inductive interference

Note

All coils in the cabinet must be interference-suppressed. Valves and motor brakes are frequently forgotten. Fluorescent lamps in the switching cabinet must be subjected to a special test.

3.5.7 Equipotential Bonding

Differing system part layouts and differing voltage levels can cause differences in potential between the parts of a system. When the system parts are connected via signal lines, equalizing currents flow through these signal lines. These equalizing currents can distort the signals.

This makes correct equipotential bonding imperative.

- The cross section of the equipotential bonding line must be large enough (i.e., at least 10 mm²).
- The space between signal cable and related equipotential bonding line must be kept as small as possible (i.e., antenna effect).
- A fine-wire line must be used (i.e., better conduction of high frequencies).
- When connecting equipotential bonding lines to the central equipotential bonding rail, power components and non-power components must be combined.

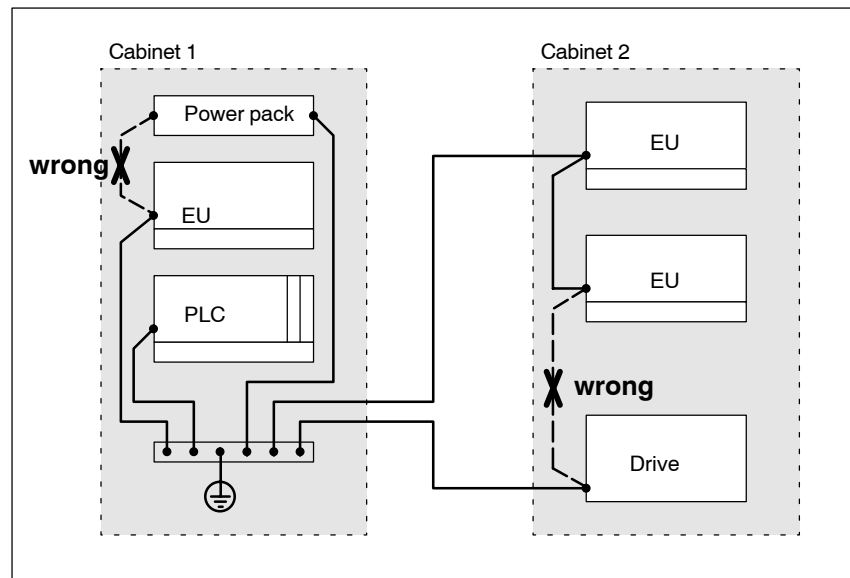

Figure 3-23 Equipotential bonding

The better the equipotential bonding in a system, the smaller the chance of interference caused by fluctuations in potential.

Equipotential bonding should not be confused with the protective grounding of a system. Protective grounding prevents the creation of excessive touch voltages when devices malfunction.

3.5.8 Ground Fault Monitoring with MOBY

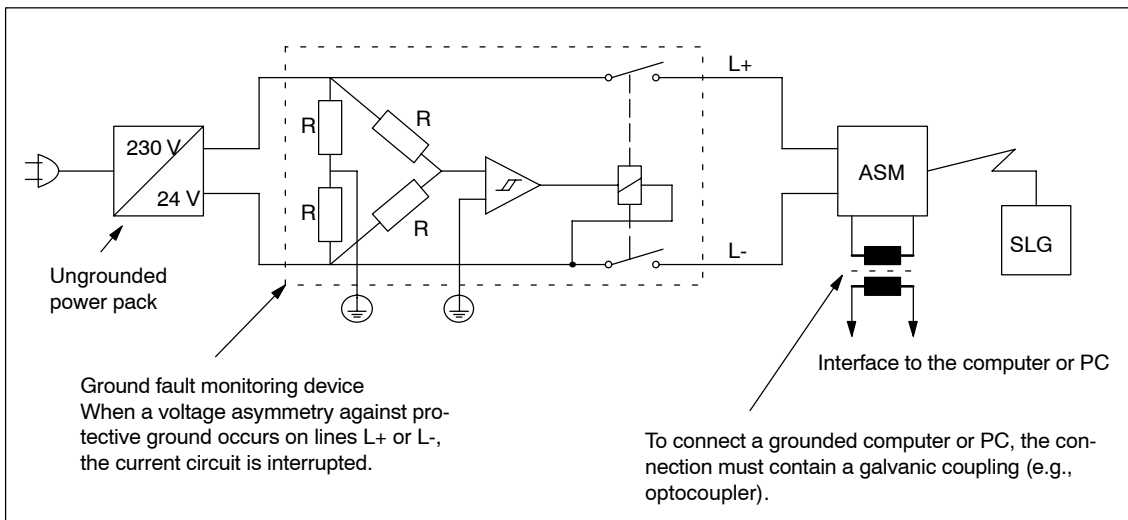

Figure 3-24 Circuit diagram of the principle of grounding fault monitoring

SIMATIC with ASM 400

The SIMATIC is a grounded system. In the power pack of the SIMATIC, 0 V (i.e., signal ground) is connected to the housing. On the ASM 400, the 0 V signal of the external 24 V power pack is connected with 0 V of the SIMATIC. The connection between the ASM 400 (SIMATIC) and the SLG is equipotentially bonded (i.e., RS 422 interface without galvanic isolation). **A direct setup with grounding fault monitoring is not possible.** Proceed as described in the SIMATIC manual if grounding fault monitoring is necessary.

SIMATIC AG 100U with ASM 410

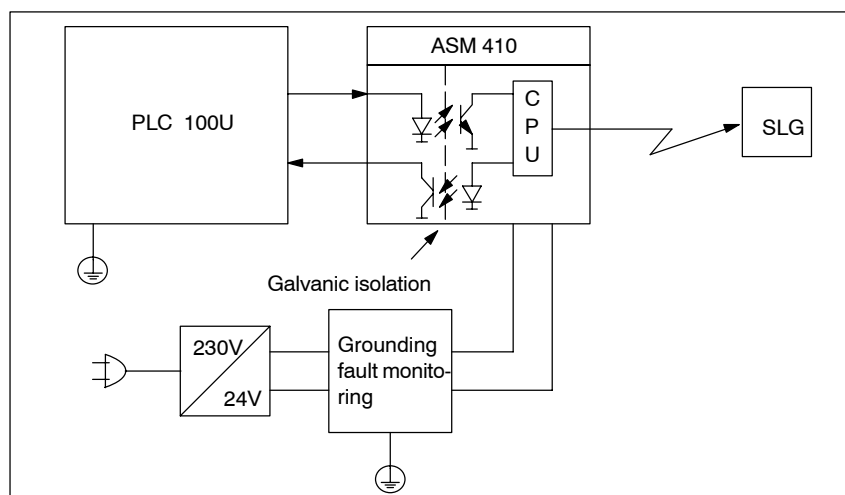

Figure 3-25 SIMATIC PLC 100U with ASM 410

The ASM 410 is equipped with galvanic isolation to the SIMATIC CPU. A layout with grounding fault monitoring is simple.

3.5.9 Shielding the Cables

To suppress interference in the signal cables, these cables must be shielded.

The best shielding effect is achieved by installation in steel piping. However, this is only necessary when the signal lines must pass through an interference-prone environment. In most cases, the use of braided shields is sufficient. In either situation, correct connection is decisive for the shielding action.

Note

A shield which is not connected at all or is connected incorrectly has no shielding effect.

The following principles apply.

- For analog signal lines, the shield connection must be one-sided and on the receiver side.
- For digital signal lines, the shield connection must be two-sided on the housing.
- Since interference signals are frequently in the HF range (i.e., > 10 kHz), connection of the HF-capacity shield must be provided over a large surface.

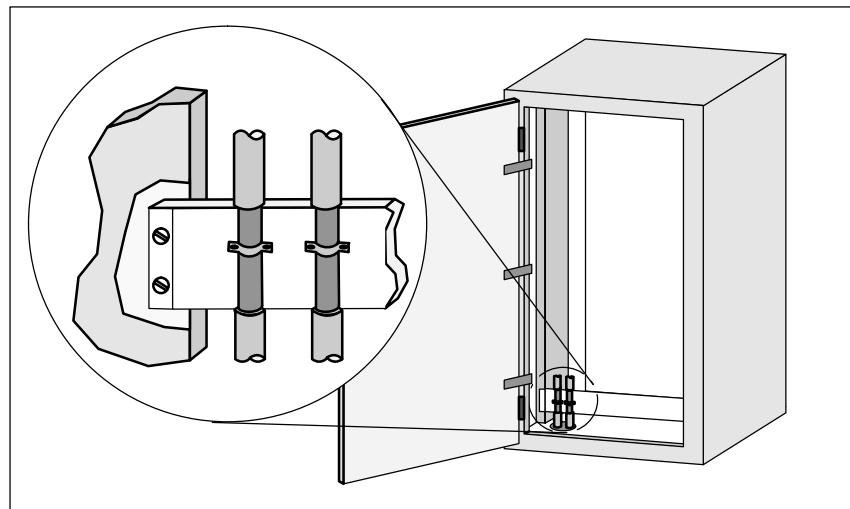

Figure 3-26 Shielding of the cables

The shield rail must be connected to the housing of the switching cabinet over a large surface (i.e., good conductivity) and must be located as close to the cable lead-in as possible. The cables must be bared and clamped (high-frequency clamp) to the shield rail or be bound with cable binders. The location must have good conductivity.

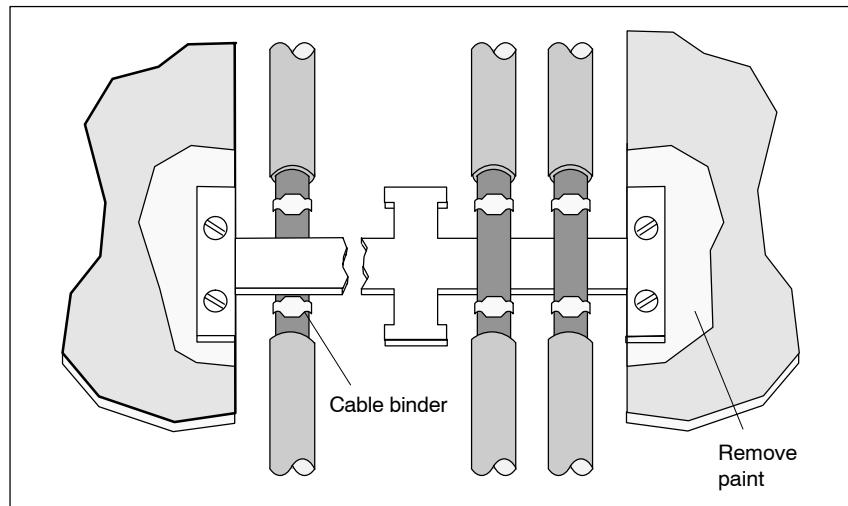

Figure 3-27 Connection of the shield rail

The shield bar must be connected with the protective ground (PE) bar.

When shielded cables must be interrupted, the shield must also be applied to the plug connector housing. Only suitable plug connectors may be used.

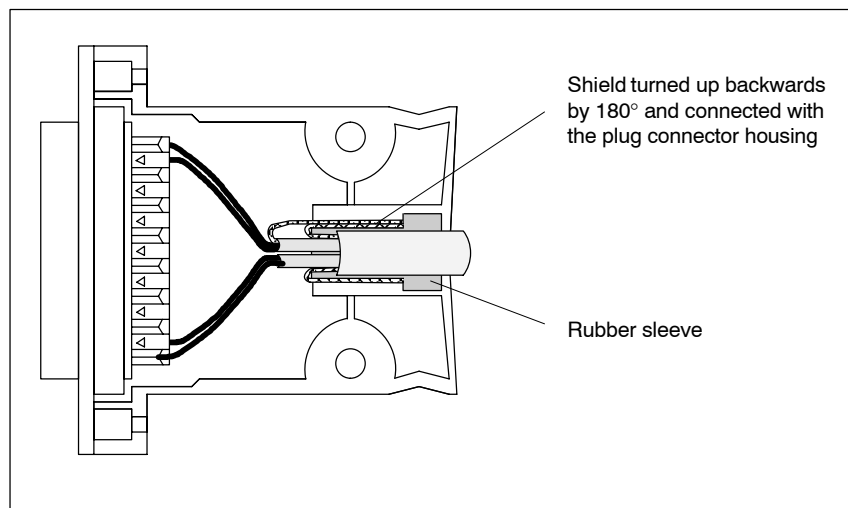

Figure 3-28 Interruption of shielded cables

When adapter plugs which do not have suitable shield termination are used, the shield must be continued through cable clamps to the point of interruption. This ensures a large-surface, HF conductive connection.

3.5.10 Basic Rules on EMC

Electromagnetic compatibility (i.e., EMC) can often be ensured by following a few elementary rules. Rules which apply to the layout of the cabinet are listed below.

Shielding via housing

- Protect the programmable controller from external interference by installing it in a cabinet or housing. The cabinet or the housing must be included in the grounding connection.
- Shield electromagnetic fields of inductivity from the programmable controller with separator plates.
- Use metallic plug housings for shielded data transmission lines.

Large-surface grounding connection

- Connect all inactive metal parts with low HF resistance over a large surface.
- Provide a large-surface connection between the inactive metal parts and the central grounding point.
- Remember to connect the shield bar to ground (i.e., a large-area connection of the shield bar to ground must be provided).
- Aluminum parts should not be used for grounding connections.

Planning the cabling

- Organize the cables into groups, and install these groups separately.
- Always install high-voltage current lines and signal lines in separate ducts or bundles.
- Introduce all cabling into the cabinet from only one side and, if possible, at one level.
- Install the signal lines as close to the grounding surfaces as possible.
- Twist the feeder and return conductors of individually installed conductors.

Shielding the lines

- Shield the data transmission lines, and apply the shield on both sides.
- Shield the analog lines, and apply the shield on one side (e.g., on the drive).
- Always apply the line shields at the cabinet entrance to the shield bar over a large surface, and secure these with clamps.
- Continue the applied shield without interruption to the module.
- Use braided shields and not foil shields.

Power supply and signal filter

- Only use power supply filters with metal housings.
- Connect the filter housing (i.e., connection must be low HF resistant and over a large surface) to cabinet ground.
- Never secure the filter housing to painted surfaces.
- Secure the filter at the cabinet entrance or in the direction of the interference source.

3.6 Concept of MOBY Shielding

With MOBY the data are transferred between ASM and SLG over an RS 422 interface at a speed of 19200 baud. The distance between ASM and SLG may be up to 1000 m. MOBY cable installation should be treated the same as that of a data processing system. Special attention should be paid to shielding of all data cables. The following figure shows the primary points required for a secure layout.

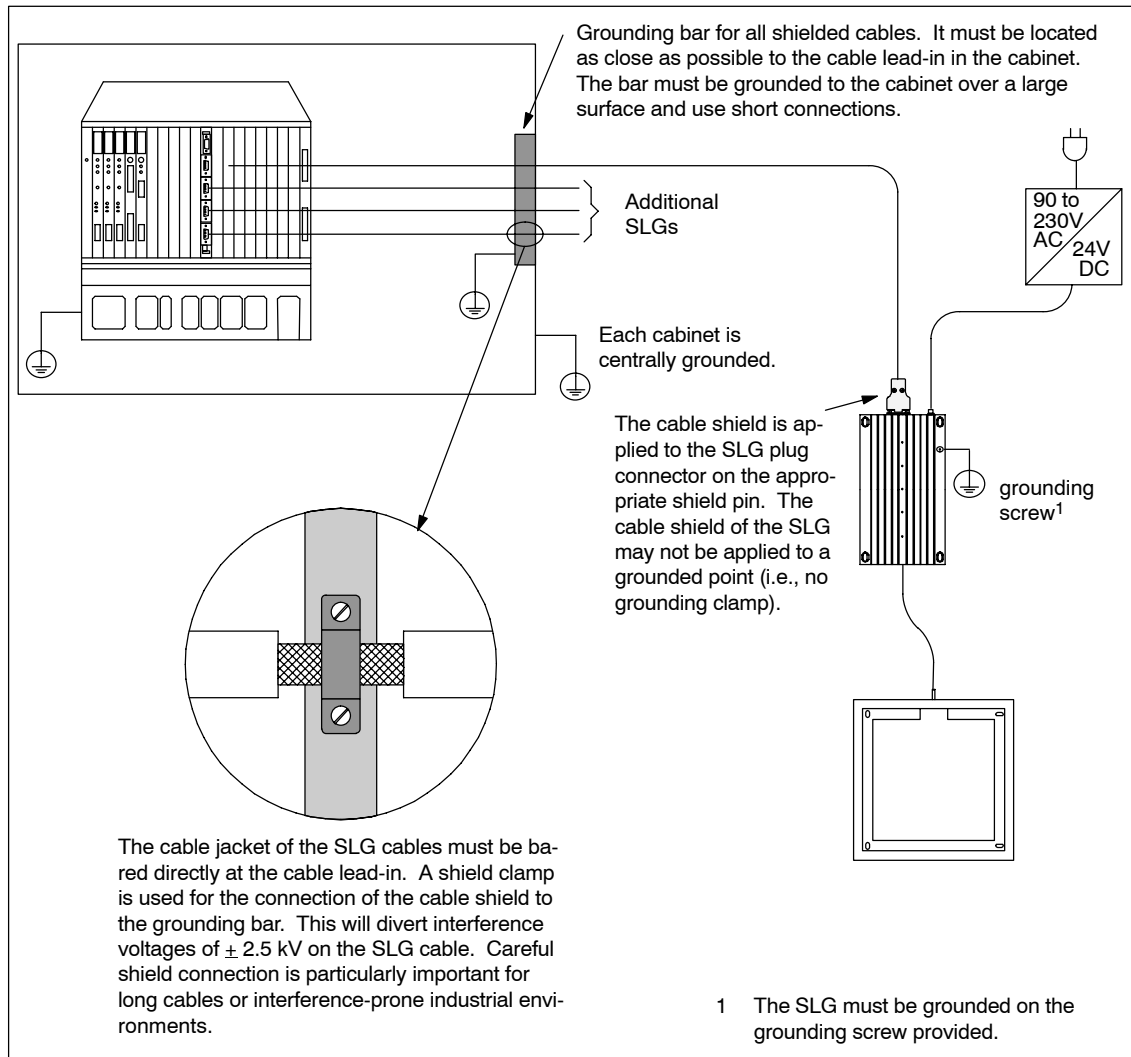

Figure 3-29 Simple layout with ASM 400

Connection of other modules (e.g., ASM 410)

To divert interference which can occur on the connection cable to the SLG, use the same measures as described for the ASM 400.

Layout of an S7-300 with MOBY

When connecting the SLG to the ASM 470, it is essential that a shield connection terminal be used for the cable shield. Shield connection terminals and holders are standard components of the S7-300 product family.

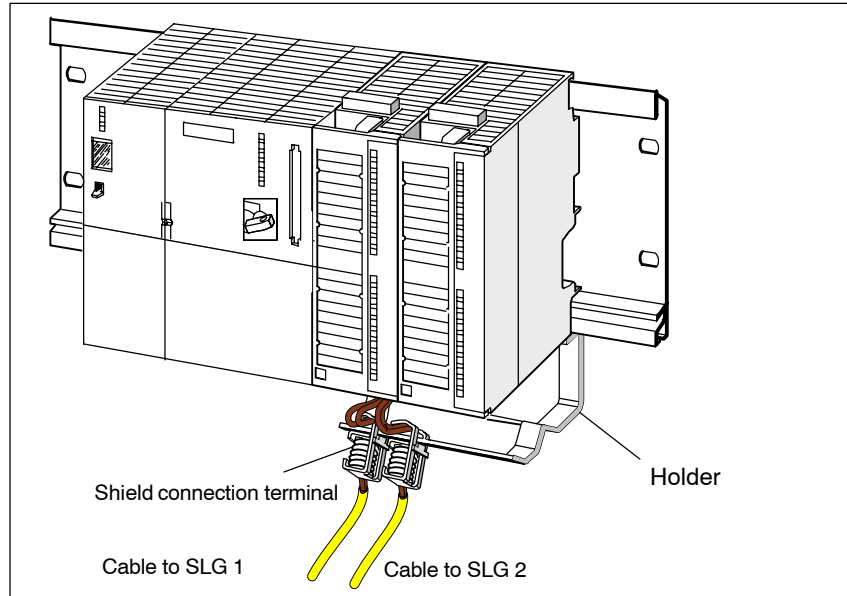

Figure 3-30 Layout of the ASM 470 with shield connecting element

Cabling for ASM 470

To ensure EMC, an S7-300 shield connecting element must be used for the SLG cable. See figure 3-30. The shield of the SLG cable must be bared as shown in figure 3-31.

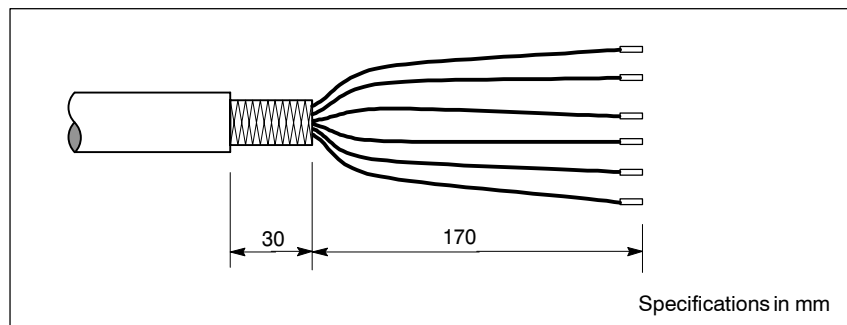

Figure 3-31 Baring of the cable shield

3.7 Cable and Plug Connector Allocation

The cable jacket used for the standard MOBY SLG/SIM data cable is made of polyurethane (PUR in accordance with VDE 0250). This provides excellent resistance to oils, acids, lye and hydraulic liquids.

3.7.1 Cable Configuration

The cable between the ASM and the SLG requires five cores + shield. The data can be transmitted over distances up to 1000 m almost regardless of the wire diameter. Standard cable LiYC11Y recommended by Siemens (see table 3-25 for standard plug-in lines).

Grounding the SLG 80 ANT F5 data cable

We recommend always leading (large area) the shield of the SLG 80 ANT F5 cable to a grounding rail.

Cable with drag capability

The SLG/SIM can also be connected with a cable with drag capability. Recommended cable type: HPM Paartronic 3340-C-PUR $3 \times 2 \times 0.25$. The cable can be made by the customer.

Voltage supply for the SLG/SIM/ASM 824/850/854

The voltage supply of the SLG / SIM / ASM 824/850/854 is provided by a 4-pole plug connector. **It is essential to consider the voltage drop on the supply cable.** The permissible length of the voltage supply cable depends on the current consumption of the SLG / SIM / ASM 824/850/854 and on the ohmic resistance of the connection cable.

Table 3-15 Voltage supply of the SLG/SIM 80 ANT F5 and SLG/SIM 82

	SLG/SIM 80 ANT F5	SLG/SIM 82
Nominal value	24 V DC	24 V DC
Permissible range	20 to 30 V (meas. on plug of SLG/SIM)	20 to 30 V (meas. on plug of SLG/SIM)
Current consumption		
Startup current	1.5 A	1.1 A
At 24 V	0.6 A (without DO) 1.1 A (with DO, only SIM)	0.25 A –

Table 3-16 Maximum ripple of the supply voltage for SLG/SIM 80 (based on frequency range)

f_{ripple} (kHz)	$U_{\text{ripple max.}}$ (mV RMS)
$f_{\text{ripple}} < 0.5$	48
$0.5 \leq f_{\text{ripple}} < 20$	7
$20 \leq f_{\text{ripple}} < 120$	36
$120 \leq f_{\text{ripple}} < 130$	12
$f_{\text{ripple}} > 130$	48

Note

For SLG/SIM 80 ANT F5

When a switching power pack is used, make sure that the switching frequency is in the range of $160 \text{ kHz} < f_{\text{switch}} < 200 \text{ kHz}$.

3.7.2 Plug Connector Allocations

**SLG/SIM 80 ANT F5
SLG 82**

Plug connector on
SLG/SIM

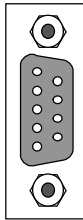

9-pole submini D plug
connector with screw-
type lock

Table 3-17 Plug connector allocation of the SLG/SIM 80 ANT F5/SLG 82 plug connector (pin housing side)

Pin	Designation	
	SLG 80 ANT F5 SLG 82 (RS 422)	SIM 80 ANT F5 (RS 232)
1	Cable shield	Cable shield
2	+ Receive	TxD Send
3	+ Send	RxD Receive
4	Not used	Digital input
5	- Send	Ground (0 V)
6	- Receive	Not used
7	Ground (0 V)	Not used
8	Cable shield	Cable shield
9	Not used	Digital output
Housing	Not used	Not used



Caution

If metallized sub D housings are used on the SLG/SIM side, the housing must be connected with the cable shield.

ASM 400

Plug connector on ASM 400

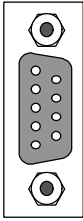

9-pole submin D plug connector with screw-type lock

Table 3-18 Plug connector allocation of the 9-pole submin D¹ (socket housing side)

Socket	Designation
1	Not used
2	+ Send
3	+ Receive
4	Not used
5	- Receive
6	- Send
7	Ground (0 V)
8	Not used
9	Not used
Housing	Cable shield

1 This plug connector allocation is valid for ASM 400 => SLG

ASM 824/850/854

Plug connector on SLG/SIM 82. ASM 824/850/854 (to SLA 81/SLA 82)

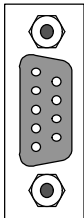

9-pole submin D plug connector with screw-type lock

Table 3-19 Plug connector allocation of the 9-pole submin D¹ (socket housing side)

Socket	Designation
1	+6.6 Volt
2	+ Send
3	+ Receive
4	CLK +
5	- Receive
6	- Send
7	Ground (0 V)
8	+24 Volt
9	CLK -
Housing	Cable shield

1 This plug connector allocation is valid for SLG 82, SIM 82, ASM 824, ASM 850, ASM 854 <=> SLA 81/SLA 82

SLA 81/SLA 82

Table 3-20 Plug connector allocation of SLA plug connector¹
(pin housing side)

Plug connector on SLA 81

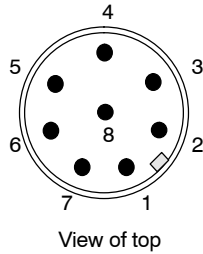

Pin	Designation
1	+6.6 Volt
2	+ Send
3	+ Receive
4	CLK +
5	- Receive
6	- Send
7	CLK -
8	Ground (0 V)

¹ This plug connector allocation is valid for
SLA 81/SLA 82 <=> SLG 82, SIM 82, ASM 824, ASM 850, ASM 854

Table 3-21 Plug connector allocation of the 9-pole submin D¹
(socket housing side)

Plug "SERIAL" on
SIM 82, ASM 824/850/854

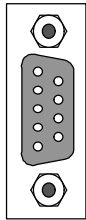

9-pole submin D plug
connector with screw-
type lock

Socket	Designation	
	RS 232	RS 422
1	Not used	Not used
2	TxD (send)	D- (send)
3	RxD (receive)	E- (receive)
4	Not used	Not used
5	Ground (0 V)	Ground (0 V)
6	Not used	Not used
7	Not used	Not used
8	Not used	D+ (send)
9	Not used	E+ (receive)
Housing	Cable shield	Cable shield

¹ This plug connector allocation is valid for
SIM 82, ASM 824, ASM 850, ASM 854 (plug "SERIAL").

Ordering data

Table 3-22 Ordering data for counterplug IP65

Counterplug IP65 for SLG and SIM (9-pin, submin, D plug connector, socket)	6GT2 490-1AA00
---	----------------

Voltage supply plug connector on SLG/SIM on SLG 80/82. SIM 80/82. ASM 824/850/854

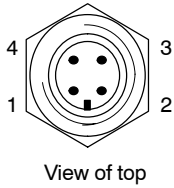

Table 3-23 Plug connector allocation of 4-pole voltage supply plug connector (pin housing side)

Pin	Designation
1	Ground (0 V)
2	+ 24 V
3	+ 24 V
4	Ground (0 V)

Ordering data

Table 3-24 Ordering data for voltage supply plug

Plug for voltage supply (socket) for SLG/SIM 82, ASM 824/850/854	6GT2 390-1AB00
--	----------------

3.7.3 Connection Cables

Connection cable
for
ASM 400 ↔ SLG
6GT2 491-0A...

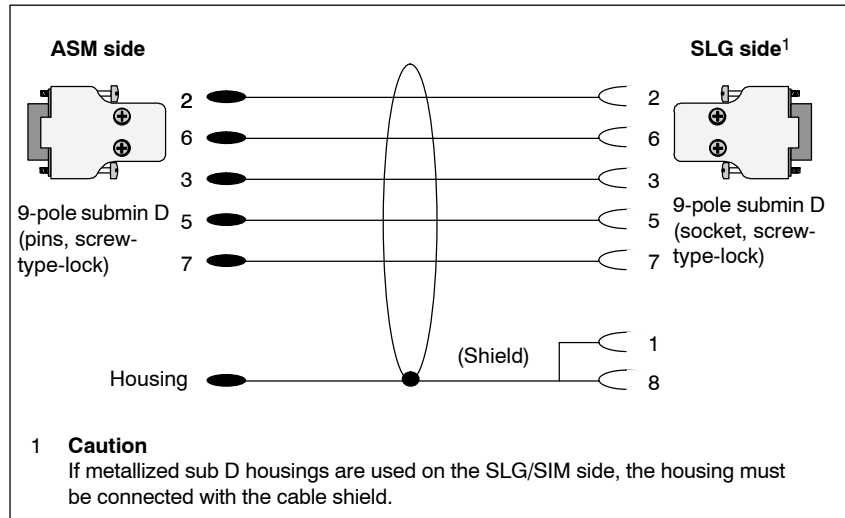

Figure 3-32 Connection cable: ASM 400 ↔ SLG

Connection cable
for
ASM 410 ↔ SLG
6GT2 491-0D...

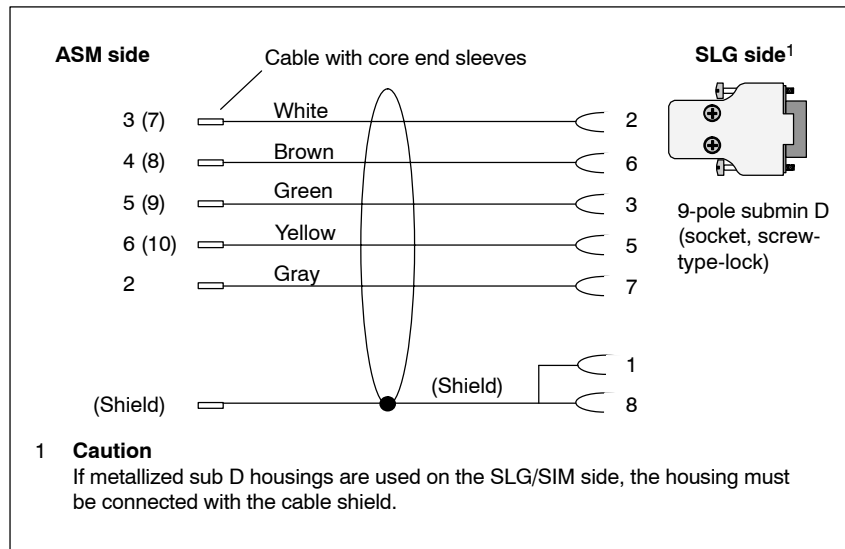

Figure 3-33 Connection cable: ASM 410 ↔ SLG



Caution

The cable shield must be secured with a shield clamp directly on the interface module and grounded via a grounding rail.

**Connection cable for
ASM 450/452/473
↔ SLG
6GT2 491-1C...**

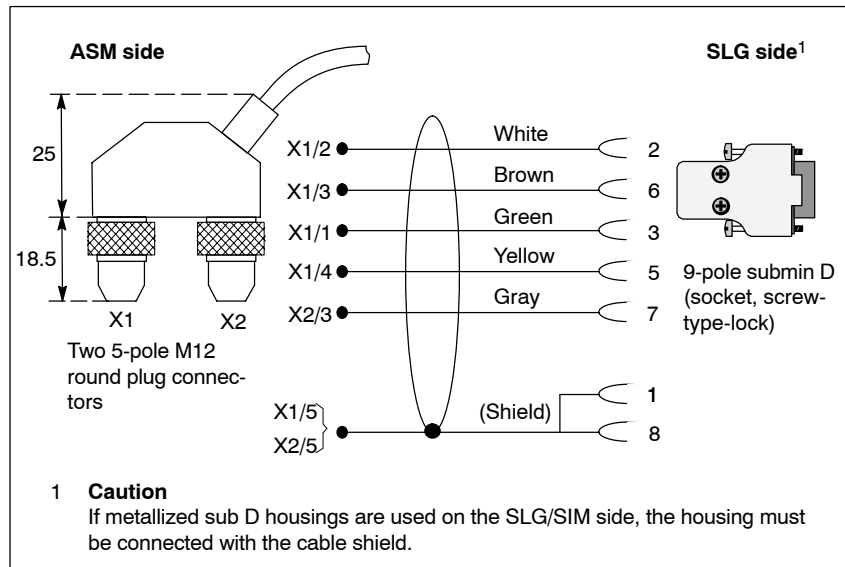

Figure 3-34 Connection cable: ASM 450/452/473 ↔ SLG

**Connection cable for
ASM 470/475
↔ SLG
6GT2 491-0E...**

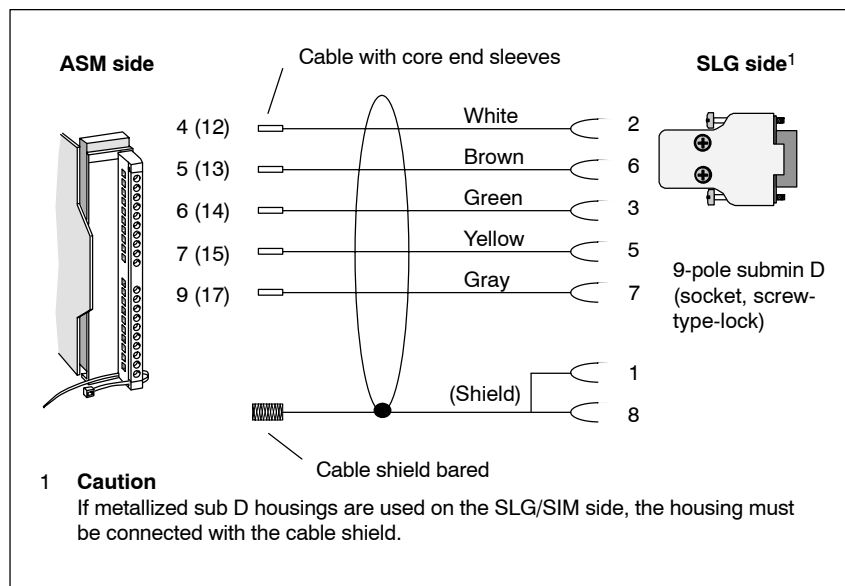

Figure 3-35 Connection cable: ASM 470/475 ↔ SLG

Note

The SLG voltage supply cannot be connected via the ASM.

Connection cable
RS 232; PC ↔
SIM 80 ANT F5
6GT2 491-1DH50

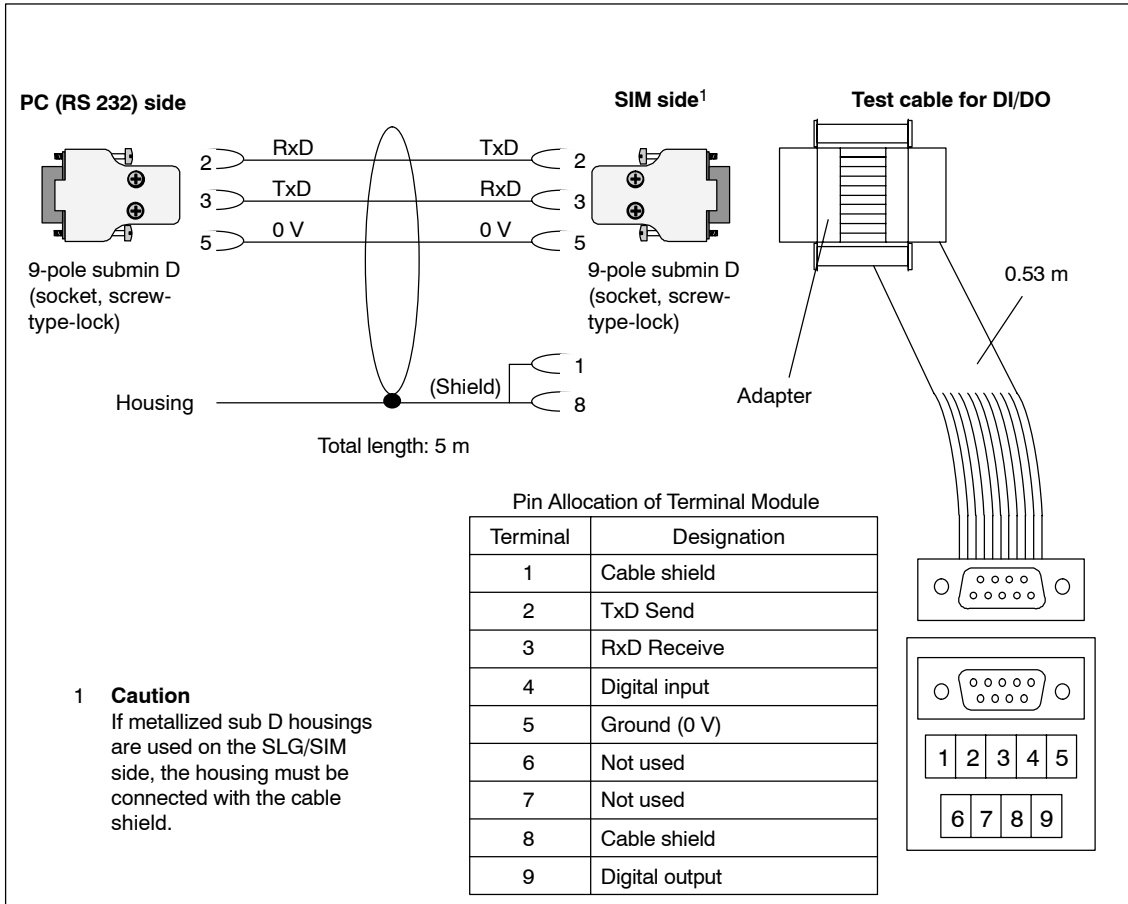

Figure 3-36 Connection cable: PC ↔ SIM 80 ANT F5 (not for SIM 82)

Connecting cable
RS 232; PC ↔ SLG
6GT2 691-0BH50
6GT2 691-0BN20

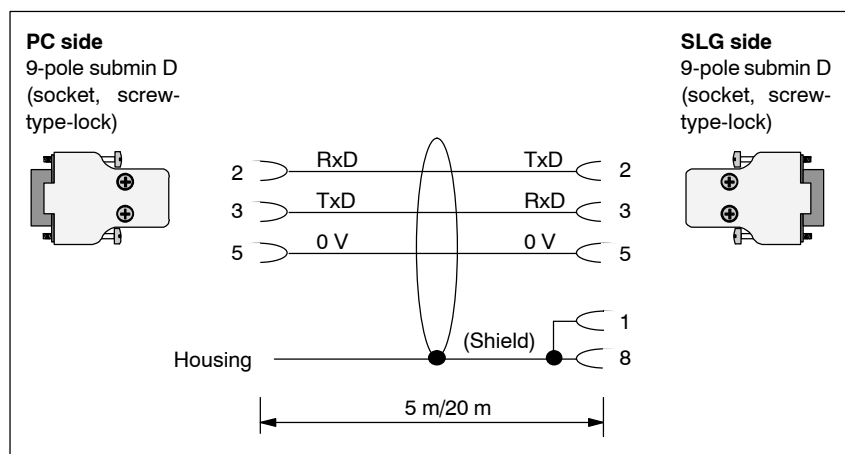

Figure 3-37 Connecting cable RS 232 PC ↔ SLG

**Connection cable
RS 232
PC ↔ SIM 82/
ASM 824
6GT2 391-0BH50**

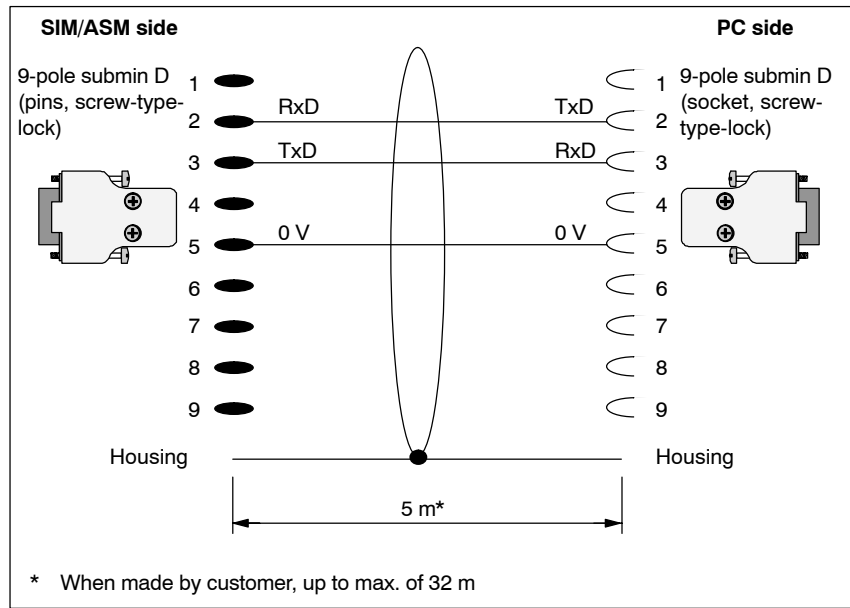

Figure 3-38 Connection cable, RS 232 PC ↔ SIM 82/ASM 824

**Connection cable
SLG/SIM 82;
ASM 824/850/854
↔ SLA 81/SLA 82
6GT2 391-1AH50**

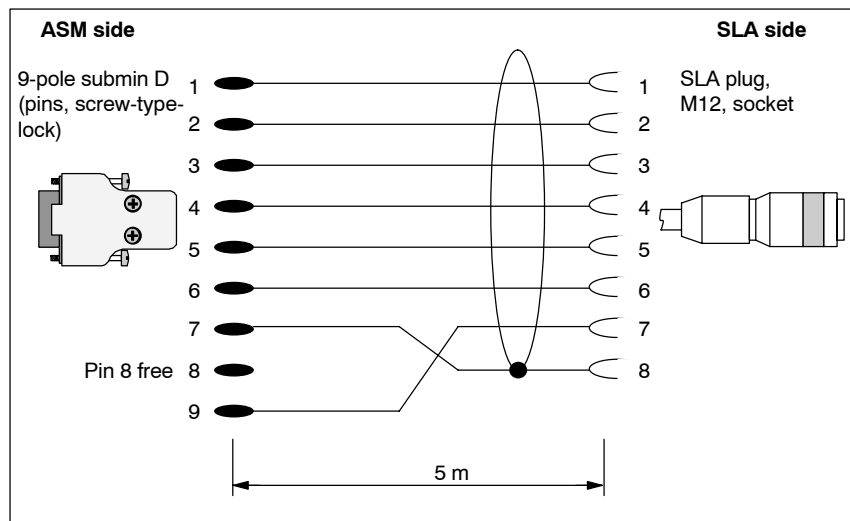

Figure 3-39 Connection cable, SLG/SIM 82; ASM 824/850/854 ↔ SLA 81/SLA 82

**Extension cable,
SLG/SIM 82;
ASM 824/850/854
↔ SLA 81/SLA 82
6GT2 391-1BN10
6GT2 391-1BN25**

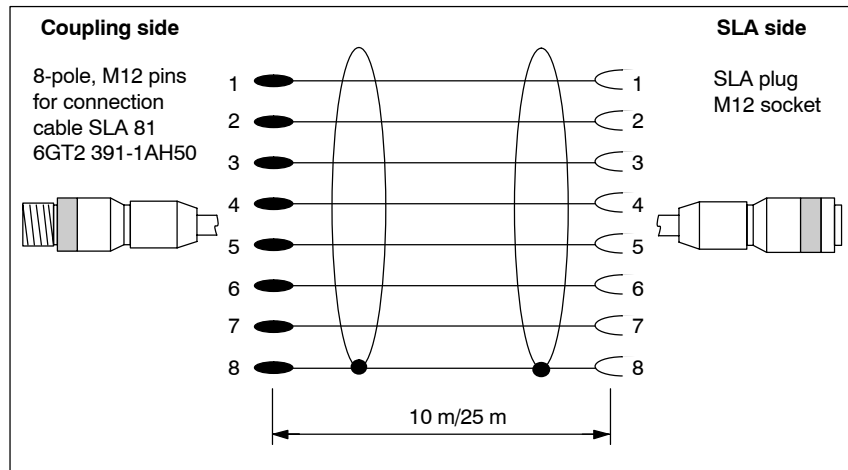

Figure 3-40 Extension cable, SLG/SIM 82; ASM 824/850/854 ↔ SLA 81/SLA 82

**24 V DC stub line
SLG 80/82;
SIM 80/82;
ASM 824/850/854
↔ MOBY wide-
range power pack
6GT2 491-1HH50**

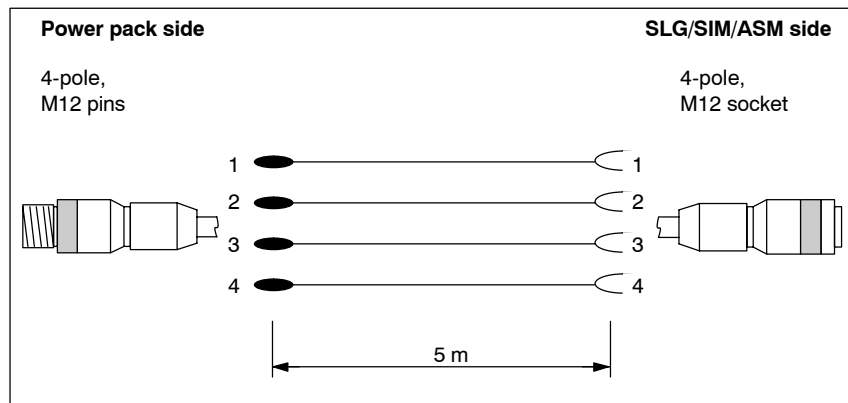

Figure 3-41 24 V DC stub line SLG/SIM/ASM ↔ MOBY wide-range power pack

3.7.4 Cable length

The length key for MOBY cables is no longer supported as of 10.01.2001 and cables are now only offered in certain lengths (see table 3-25).

Cable fabrication by the customer continues to be possible in all lengths.

Table 3-25 Ordering data for MOBY cables

SLG stub line, ready for use		
Between		
• ASM 400 and SLG 8x	Length: 5 m 20 m	6GT2 491-0AH50 6GT2 491-0AN20
• ASM 410 and SLG 8x	Length: 5 m 20 m	6GT2 491-0DH50 6GT2 491-0DN20
• ASM 450/452/473 and SLG 8x	Length: 2 m 5 m 20 m	6GT2 491-1CH20 6GT2 491-1CH50 6GT2 491-1CN20
• ASM 470/475 and SLG 8x	Length: 5 m 20 m 50 m	6GT2 491-0EH50 6GT2 491-0EN20 6GT2 491-0EN50
Standard connection cable between SLA 81/SLA 82 ↔ ASM 824/850/854 (Length: 5 m, not included with the SLA)		6GT2 391-1AH50
Extension for antenna line SLA 81/SLA 82 6GT2 391-1AH50		
	Length: 10 m 25 m	6GT2 391-1BN10 6GT2 391-1BN25
Stub line, 24 V		
24 V DC stub line for wide-range power pack 6GT2 494-0AA00		
	Length: 5 m	6GT2 491-1HH50
RS 232 stub line		
Between PC and ASM 824 or SIM 82		
	Length: 5 m	6GT2 391-0BH50
Between PC and SLG 8x		
	Length: 5 m 20 m	6GT2 691-0BH50 6GT2 691-0BN20
Between PC and SIM 80 ANT F5		
	Length: 5 m	6GT2 491-1DH50

Mobile Data Memories

4

4.1 Introduction

Application area

With MOBY, identification is automatic, fast and reliable. The data stored on a mobile data memory (i.e., MDS) accompany a product, work piece carrier, or a transport or packaging unit throughout the entire material flow process.

The MDS is available in various models to permit specific selection for the desired application. When an MDS is affixed to the unit to be identified, data can be stored inductively (i.e., no contact required) on the MDS and updated inductively or read at every stage of the material flow process.

The sturdy construction of the MDSs permits use under very rugged conditions and ensures resistance to many chemical substances.

Layout and functions

Mobile data memories (MDSs) are built from the following primary components.

- Antenna – receipt of power and receipt/sending of data signals
- Logic – A/D-D/A conversion, memory access and data backup
- Memory – fixed code (read-only) or EEPROM memory (read-write), depending on the model
- Housing – reliable protection against environmental conditions

When an MDS moves into the transmission field of the read/write device (SLG), it is powered by this field. The logic monitors the power supply and handles conversion of the analog-modulated signals into digital information. Depending on the requested function, the logic performs test and memory operations and sends appropriately converted analog-modulated signals back to the SLG.

MOBY F offers MDSs with fixed code (read-only) and EEPROM memories (read-write).

Übersicht

Table 4-1 Overview of the MDS

MDS Type	Memory Size	Temperature Range (During Operation)	Dimensions (D x H) in mm	Protection Rating
MDS F124	40-bit fixed code	-25° to +100° C	∅ 30 x 1	IP67
MDS F125	40-bit fixed code	-25° to +100° C	∅ 50 x 1	IP67
MDS F160	40-bit fixed code	-25° to +85° C	∅ 16 x 3	IP68
MDS F415	256-byte EEPROM ¹	-25° to +100° C	∅ 50 x 1	IP67

¹ 192-byte EEPROM can be used with SLG. 224-byte EEPROM can be used with SIM.

**Operational requirements/
environmental requirements**

Table 4-2 Operational requirements/environmental requirements of MDS

	MDS F124/MDS F125/ MDS F160/MDS F415
Proof of mechanical stability is provided by oscillation test in accordance with: Test conditions: Frequency range Amplitude excursion Acceleration Test duration per axis	EN 60721-3-7, class 7M3 2 to 500 Hz 7.5 mm (2 to 9 Hz) 2 g (9 to 200 Hz) 4 g (200 to 500 Hz) 20 frequency cycles
Proof of mechanical stability via continuous shock stress in accordance with: Test conditions: Acceleration Duration Test duration per axis	EN 60721-3-7, class 7M3 100 g 6 msec 500 impacts per axis
Protection rating	IP67/IP68 in acc. w. EN 60529
Ambient temperature During operation During transportation and storage	-25 °C to +85/+100 °C -25/-40 °C to +100/+130 °C
Temperature gradient in storage temperature range in acc. w. part 2-4 of DIN IEC 68	3° C/min
Temperature gradient for fast temperature change in acc. w. part 2-14 of DIN IEC 68	Duration: 30 min per extreme Change from one extreme to other: Approx. 10 sec, 100 cycles
Torsion and bending stress	Not permitted
MTBF	2.5 x 10 ⁶ hours

Definition of IP67

- Protection against penetration of dust (i.e., dust-proof)
- Full protection against touch
- Protection against water under specified pressure and time

Definition of IP68

- Protection against penetration of dust (i.e., dust-proof)
- Full protection against touch
- The MDS can be immersed in water (24 hr, 2 m).

4.2 MDS F124



Figure 4-1 MDS F124

Ordering data

Table 4-3 Ordering data for MDS F124

	Order No.
MDS F124 mobile data memory 40-bit fixed code	6GT2 400-1CE00

Technical data

Table 4-4 Technical data of MDS F124

Memory size	40 bits (ID no.)
Memory organization	Fixed code
Multi-tag capability	No
MTBF	2.5 x 10 ⁶ hours
Read cycles	Unlimited
Read distance	See field data.
Vibration	20 g
Shock	100 g
Torsion and bending stress	Not permitted
Direction dependency	No
Securing of MDS	Adhesive, recessed head screw (M3)
Turning moment at + 20° C	≤ 1 Nm
Protection rating in acc. w. EN 60529	IP67
Physical design	Pressed, impact-proof epoxide material
Color	Black
Material	Epoxide resin
Dimensions (D x H) in mm	∅ 30 x 1

Table 4-4 Technical data of MDS F124

Ambient temperature	
During operation	-25° C to +100° C
During transportation and storage	-40° C to +130° C
Weight (approx.)	5 g



Caution

When switching through the SLG/SIM supply voltage, make sure that there is no MDS F124 in the transmission window of the SLG/SIM antenna.

Field data

Table 4-5 Field data of MDS F124

	SLG 80/ SIM 80 ANT F5	SLG 82/ SIM 82/ SLA 81	SLA 82
Operating distance (S _a)	0 to 240 mm	0 to 65 mm	0 to 140 mm
Limit distance (S _g)	280 mm	80 mm	160 mm
Transmission window (L)	280 mm	Ø 70 mm	Ø 120 mm
Minimum distance from MDS to MDS	≥ 1 m	≥ 0.3 m	≥ 0.6 m

**Dimensions
(in mm)**

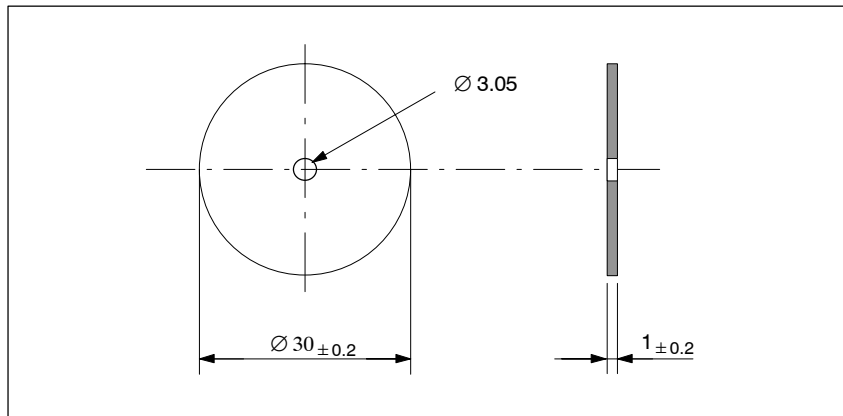

Figure 4-2 Dimensions of the MDS F124

Metal-free space

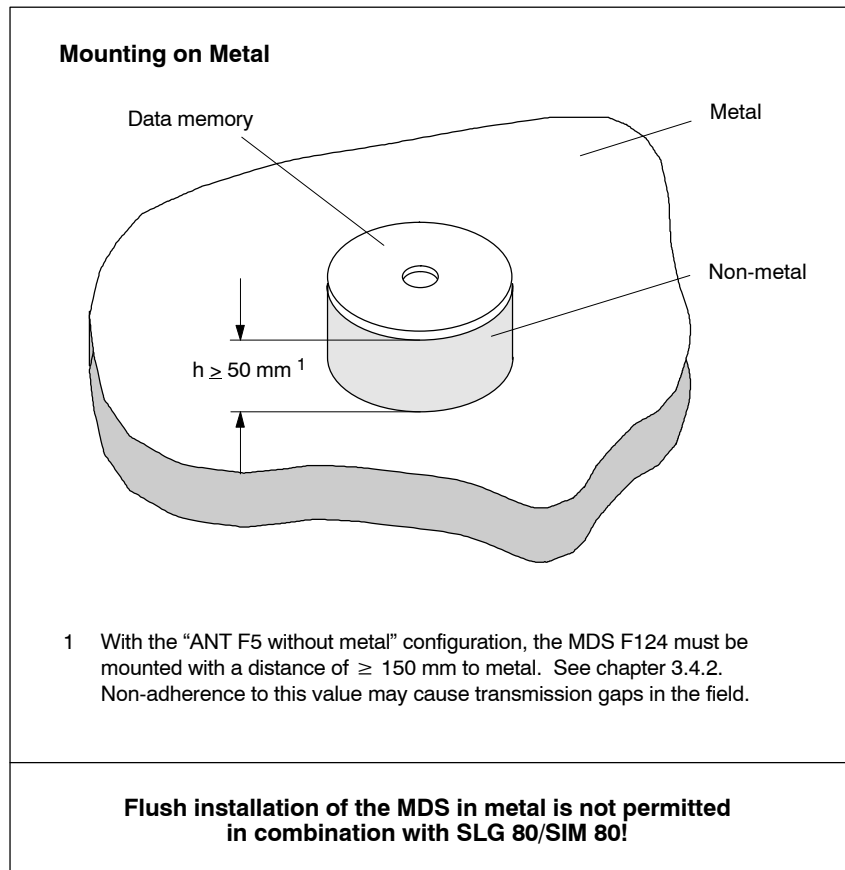

Figure 4-3 Metal-free space for the MDS F124

Note

Underranging the guideline values (h) will significantly decrease the field data. See chap. 3.4.2. Mounting of the MDS with metal screws (M3 cylinder head) is possible. This does not noticeably reduce its range. A test is recommended for critical applications.

For installation in metallic environment, read and adhere to the information in chapter 3.4.2.

4.3 MDS F125



Figure 4-4 MDS F125

Ordering data

Table 4-6 Ordering data for MDS F125

	Order No.
MDS F125 mobile data memory 40-bit fixed code	6GT2 400-1CF00

Technical data

Table 4-7 Technical data of MDS F125

Memory size	40 bits (ID no., 5 bytes)
Memory organization	Fixed code
Multi-tag capability	No
MTBF	2.5 x 10 ⁶ hours
Read cycles	Unlimited
Read distance	See field data.
Vibration	20 g
Shock	100 g
Torsion and bending stress	Not permitted
Direction dependency	No
Securing of MDS	Adhesive, M4 screw
Turning moment at + 20° C	≤ 1Nm
Protection rating in acc. w. EN 60529	IP67
Physical design	Pressed, impact-proof epoxide material
Color	Black
Material	Epoxide material
Dimensions (D x H) in mm	Ø 50 x 1

Table 4-7 Technical data of MDS F125

Ambient temperature	
During operation	-25° C to +100° C
During transportation and storage	-40° C to +130° C
Weight (approx.)	5 g



Caution

When switching through the SLG/SIM supply voltage, make sure that there is no MDS F125 in the transmission window of the SLG/SIM antenna.

Field data

Table 4-8 Field data of MDS F125

	SLG 80/ SIM 80 ANT F5	SLG 82/ SIM 82/ SLA 81	SLA 82
Operating distance (S _a)	0 to 380 mm	0 to 110 mm	0 to 180 mm
Limit distance (S _g)	420 mm	140 mm	200 mm
Transmission window (L)	280 mm	Ø 70 mm	Ø 120 mm
Minimum distance from MDS to MDS	≥ 1 m	≥ 0.4 m	≥ 0.8 m

**Dimensions
(in mm)**

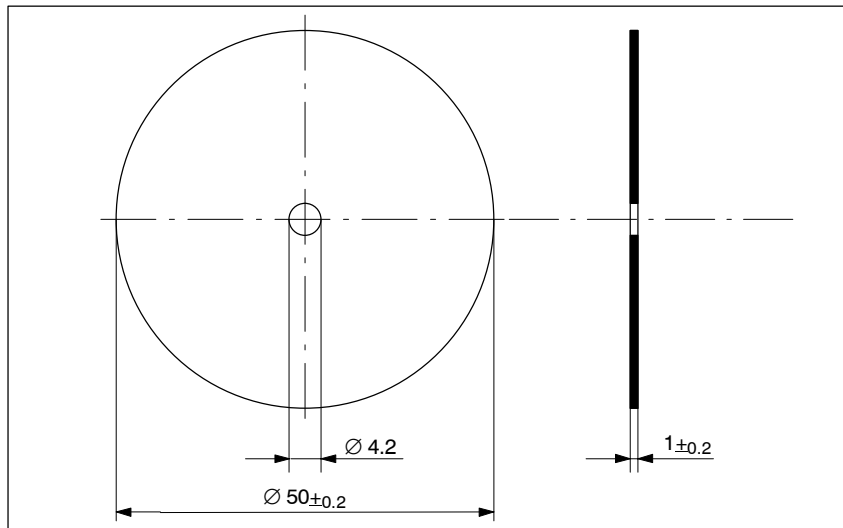

Figure 4-5 Dimensions of the MDS F125

Metal-free space

Figure 4-6 Metal-free space for the MDS F125

Note

Underranging the guideline values (h) will significantly decrease the field data. See chap. 3.4.2. Mounting of the MDS with metal screws (M4 screw) is possible. This does not noticeably reduce its range. A test is recommended for critical applications.

For installation in metallic environment, read and adhere to the information in chapter 3.4.2.

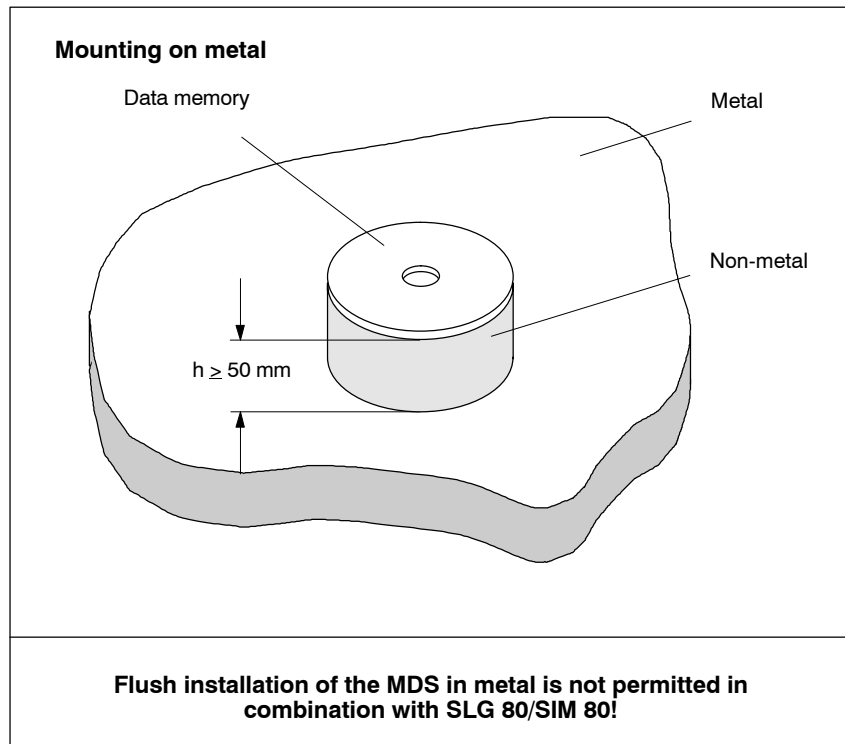
4.4 MDS F160

Application area

The MDS F160 mobile data memory was especially developed for rugged use by laundries and cleaners. A laundry tag with a limited life is available for cyclic applications.

Primary uses:

- Rental work clothes
- Surgical textiles, hospital clothes
- Hotel laundry
- Rental laundry
- Mats



Figure 4-7 MDS F160

Ordering data

Table 4-9 Ordering data for MDS F160

	Ordering Data
Mobile data memory MDS F160 40-bit fixed code	6GT2 400-1GA00

Technical data

Table 4-10 Technical data for MDS F160

Memory size	40 bits (ID number)
Memory organization	Fixed code
Multi-tag capability	No
Read cycles	Unlimited
Read distance	See field data.
Direction dependency	No
Mounting of the MDS	Glued, patch, sewn in
Protection rating	IP68 (20° C, 24 hours, 2 m)
Physical design	Pressed, shock resistant plastic
Color	Black
Material	Epoxy resin
Dimensions (D x H) in mm	Ø 16 x 3

Table 4-10 Technical data for MDS F160

Physical resistance	
Isostatic pressure	300 bar for 5 minutes
Axial pressure	800 N
Radial pressure	800 N
Ambient temperature	
During operation	-25 °C to +85 °C
During transportation and storage	-25 °C to +100 °C for 1000 hours +160 °C for 10 hours
Resistance to chemicals	All chemicals conventionally used in the laundry process
Washing cycles, min.	200
Weight, approx.	1.2 g

Note

The MDS F160 must be given a regeneration time of at least 24 hours between laundry cycles.

Field data

Table 4-11 Field data for MDS F160

	SLG 80/ SIM 80 ANT F5 ¹	SLG 82/ SIM 82/ SLA 81	SLA 82
Working distance (S _a)	0 to 140 mm	0 to 60 mm	0 to 90 mm
Limit distance (S _g)	160 mm	70 mm	120 mm
Transmission window (L)	230 mm	Ø 40 mm	Ø 120 mm
Minimum distance from MDS to MDS	≥ 1 m	≥ 0.3 m	≥ 0.6 m

- When the MDS F160 is combined with the SLG/SIM 80 ANT F5, a mounting plate of metal at a distance of 100 mm to the antenna (ANT F5) must always be used since otherwise there would be no communication or poor communication.

Dimension (in mm)

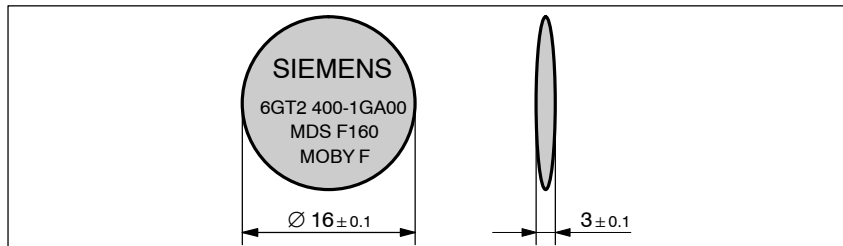

Figure 4-8 Dimensions of the MDS F160

Metal-free space

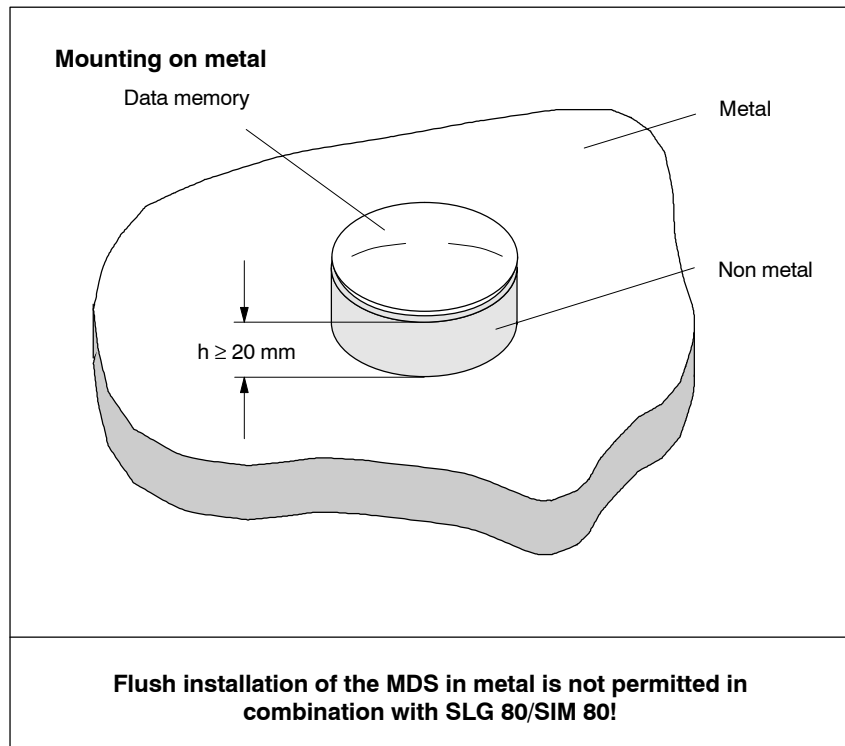

Figure 4-9 Metal-free space for the MDS F160

Note

Any type of metal (particularly iron and ferromagnetic material) in the vicinity of the MDS and SLG/SIM antennas will affect their functions. The distances to metal described above must be adhered to. Non-adherence to the metal-free space will reduce the limit and working distances.

For installation in metallic environment, read and adhere to the information in chapter 3.4.2.

4.5 MDS F415



Figure 4-10 MDS F415

Ordering data

Table 4-12 Ordering data for MDS F415

	Order No.
MDS F415 mobile data memory with 256-byte EEPROM ¹	6GT2 400-4BF00

1 192-byte EEPROM can be used with SLG. 224-byte EEPROM can be used with SIM.

Technical data

Table 4-13 Technical data of MDS F415

Memory size	256 bytes ¹
Memory organization	Random access
Multi-tag capability	Yes ²
MTBF	2.5 x 10 ⁶ hours
Read cycles	Unlimited
Write cycles, minimum	200 000
Write cycles, typical (≤ + 40° C)	> 1 000 000
Read/write distance	See field data.
Vibration	20 g
Shock	100 g
Torsion and bending stress	Not permitted
Direction dependency	No
Securing of MDS	Adhesive, M4 screw
Turning moment at + 20° C	≤ 1Nm
Protection rating in acc. w. EN 60529	IP67
Physical design	Pressed, impact-proof epoxide material

Table 4-13 Technical data of MDS F415

Color	Black
Material	Epoxide material
Dimensions (D x H) in mm	Ø 50 x 1
Ambient temperature	
During operation	-25° to +100° C
During transportation and storage	-40° to +130° C
Weight (approx.)	5 g

- 1 192-EEPROM can be used with SLG. 224-byte EEPROM can be used with SIM. See chap. 6.8 on the data structure of the MOBY F data memory MDS F4xx.
- 2 Only in combination with SIM 80 ANT F5

Memory organization of MDS F4xx

Table 4-14 Memory organization of the MDS F4xx¹

Address in Memory	Description
0 to 3	Serial number, fixed code; can be read with SLG/SIM
4 to 15	Configuration and key; only possible with SIM 80 ANT F5
16 to 31	Password assignment; only possible with SIM 80 ANT F5
32 to 63	User data; only possible with SIM 80 ANT F5
64 to 127	Read/write memory for use as desired; for user data with SLG/SIM; this area can be configured (password assignment) when SIM 80 ANT F5 is used.
128 to 255	Read/write memory for use as desired; for user data with SLG/SIM; this area cannot be configured.

- 1 See chap. 6.8 on the data structure of the MOBY F data memory MDS F4xx.

Field data

Table 4-15 Field data of MDS F415

	SLG 80/ SIM 80 ANT F5	SLG 82/ SIM 82/ SLA 81	SLA 82
Operating distance (S _a)	0 to 300 mm	15 to 90 mm	20 to 150 mm
Limit distance (S _g)	340 mm	110 mm	180 mm
Transmission window (L)	280 mm	Ø 70 mm	Ø 120 mm
Minimum distance from MDS to MDS	≥ 1 m ¹	≥ 1 m	≥ 1 m

- 1 The minimum distance can be reduced with SIM 80 ANT F5 during multi-tag operation. The MDSs can be located next to each other. MDS overlapping is not permitted.

**Dimensions
(in mm)**

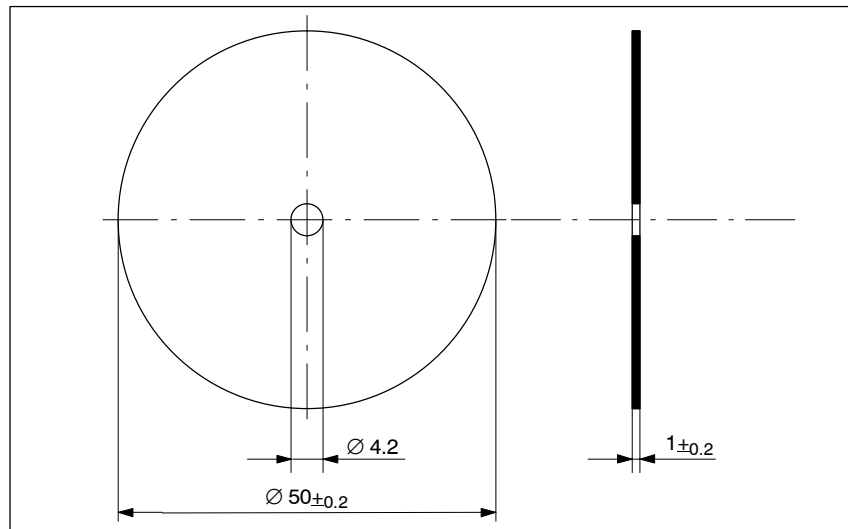

Figure 4-11 Dimensions of the MDS F415

Metal-free space

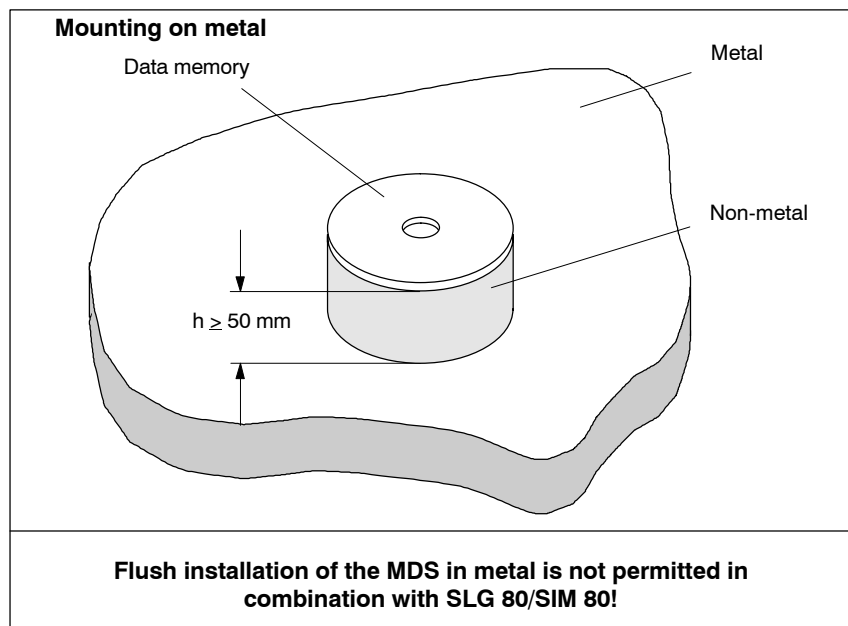

Figure 4-12 Metal-free space for the MDS F415

Note

Underranging the guideline values (h) will significantly decrease the field data. See chap. 3.4.2. Mounting of the MDS with metal screws (M4 screw) is possible. This does not noticeably reduce its range. A test is recommended for critical applications.

For installation in metallic environment, read and adhere to the information in chapter 3.4.2.

**Read/Write Devices
Read/Write Antennas**

5

5.1 Introduction

Application area In combination with the interface module (i.e., ASM), the read/write device (i.e., SLG/SLA) represents the communications interface between a host controller and the mobile data memory (i.e., MDS). The SLG/SLA permits inductive communication with the MDS. The data read from the MDS and the operations to be executed on the MDS are transferred via the serial link to/from the ASM.

Layout and functions

.A read/write device is the inductive counterpart to a mobile data memory.

- Antenna – transmission of the power field and data signals to and from the MDS
- Logic – A/D-D/A conversion of the MDS/ASM signals
- Communications unit – reliable transmission of data and commands to and from the ASM
- Housing – reliable protection against environmental conditions

The read/write device (SLG/SLA) receives commands and data from the interface module (ASM) via the serial interface. These commands and data are converted into instructions which trigger operations on the mobile data memory. Powering and communication with the MDS are performed via inductive alternating fields. The information transmitted by the MDS is returned to the ASM via the serial interface.

The amount of information which can be transmitted between SLG/SLA and MDS depends on the following factors.

- Speed at which the MDS moves past the antenna (so-called crossing window)
- Length of the inductive alternating field of the SLG/SLA through which the MDS moves (so-called transmission window)

Table 5-1 Overview table, SLG/SLA

SLG Type	Operating Distance S _a (Depending on MDS)	Limit Distance S _g (Depending on MDS)	Temperature Range (During Operation)	SLG Dimensions (L x W x H) in mm	Antenna Dimensions (L x W x H) in mm	Protection Rating
SLG 80 ANT F5	0 to 380 mm	Max. of 420 mm	-25 to +60 °C	320 x 145 x 100	350 x 350 x 20	IP65
SLG 82	0 to 110 mm	Max. of 140 mm	-25 to +55 °C	205 x 130 x 60	∅ 65 x 90	IP40
SLA 81	0 to 110 mm	Max. of 140 mm	-25 to +70 °C	–	∅ 65 x 90	IP65
SLA 82	0 to 180 mm	Max. of 200 mm	-25 to +70 °C	–	150 x 150 x 30	IP65

Definition of IP65

- Protection against penetration of dust (i.e., dust-proof)
- Full protection against touch
- Protection against water jet

Definition of IP40

- Protection against penetration of solid foreign bodies with ∅ ≥ 1.0 mm
- Protection against touching dangerous parts with wire
- Not protected against penetration by water

5.2 SLG 80 ANT F5

Application area The SLG 80 with ANT F5 is designed for applications requiring long operating distances to the MDS. In dynamic operation, the size of the transmission window generated by the ANT F5 permits high crossing speeds.

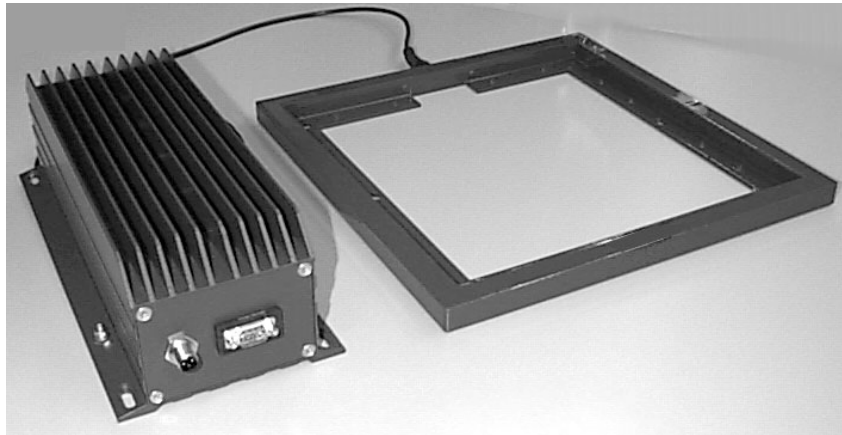

Figure 5-1 Read/write device SLG 80 ANT F5

Ordering data Table 5-2 Ordering data for the SLG 80 ANT F5

Read/write device SLG 80 ANT F5	6GT2 401-0AF00
Stub lines and accessories	See chapter 3.7.

Technical data Table 5-3 Technical data of SLG 80 ANT F5

Inductive interface to MDS Max. read distances, SLG-MDS F1xx	420 mm r/o (see field data, chap. 3.2)
Max. read/write distances, SLG-MDS F4xx	340 mm, r/w
Transmission frequency	125 kHz
Serial interface to ASM Data transmission speed Data line length (max.) Line length, antenna (See caution note.)	RS 422 9600 baud 1000 m 2 m (can be connected on the SLG side)
Supply voltage ¹ (via separate power plug connector) Nominal value Permissible range	24 V DC, linear regulated power pack or clock-pulsed switching power pack (160 to 200 kHz) 20 to 30 V DC

Table 5-3 Technical data of SLG 80 ANT F5

Current consumption at room temperature Switchon current, brief Operation (at 24 V)	Max. of 1.5 A 600 mA (typical)
MTBF	1 x 10 ⁵ hours
Housing Dimensions (in mm) For antenna head (L x W x H) For electronics w/o plug (L x W x H) Color Antenna SLG housing Material Antenna SLG housing Plug connection (data) Plug connection (counter plug for voltage supply; is included with the SLG.)	350 x 350 x 20 320 x 145 x 100 Anthracite Anthracite Aluminum Aluminum 9-pole submin plug connector (pin on device side) M12 4-pole device plug connector (IP65)
Protection rating in acc. w. EN 60529 SLG housing Antenna Shock in acc. w. EN 60721-3-7, class 7M2 Total shock-response spectrum, type II Vibration in acc. w. EN 60721-3-7, class 7M2	IP65 ² IP65 30 g 1 g (9 to 200 Hz) 1.5 g (200 to 500 Hz)
Mounting of SLG Mounting of antenna Turning moment (at room temperature)	4 M6 screws Min. of 4 M6 screws ≤ 3 Nm
Ambient temperature During operation During transportation and storage	–25° to +60° C –40° to +85° C
Weight (SLG)	Approx. 3600 g
Weight (antenna)	Approx. 1200 g

- 1 SLG power supply cannot be connected via the ASM.
- 2 IP65 only with special plug 6GT2 490-1AA00 (see chap. 3.7.2).



Caution

The antenna cable is prefabricated. Modification of the cable will invalidate the warranty and CE/BZT certification.

Field data

Table 5-4 Field data of SLG 80 ANT F5

Operating distance (S_a)	0 to 380 mm (See table 3-4.)
Limit distance (S_g)	420 mm (See table 3-4.)
Transmission window (L)	280 mm (See table 3-4.)
Minimum distance from ANT F5 to ANT F5 (D)	See figure 5-4.

FCC information**Warning**

Do not make changes on the devices.
Violation will invalidate interference emission certification (FCC) and the manufacturer's warranty.

Note

This equipment has been tested and found to comply with the limits for a Class B digital device, pursuant to Part 15 of the FCC Rules. These limits are designed to provide reasonable protection against harmful interference in a residential installation. This equipment generates, uses and can radiate radio frequency energy and, if not installed and used in accordance with the instructions, may cause harmful interference to radio communications. However, there is no guarantee that interference will not occur in a particular installation. If this equipment does cause harmful interference to radio or television reception, which can be determined by turning the equipment off and on, the user is encouraged to try to correct the interference by one or more of the following measures:

- Reorient or relocate the receiving antenna.
- Increase the separation between the equipment and receiver.
- Connect the equipment into an outlet on a circuit different from that to which the receiver is connected.
- Consult the dealer or an experienced radio/TV technician for help.

**Caution**

Use of a shielded cable for any kind of connection cable is absolutely necessary.
The cable shield must be secured with a shield clamp directly on the interface module and grounded via a grounding rail.

Transmission window

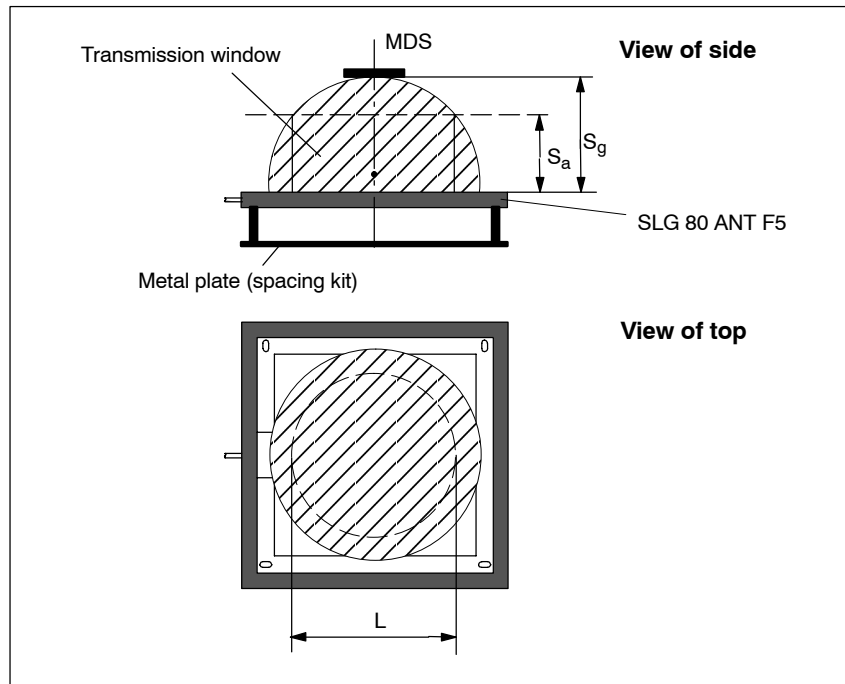

Figure 5-2 Transmission window of the SLG 80 ANT F5

Metal-free space

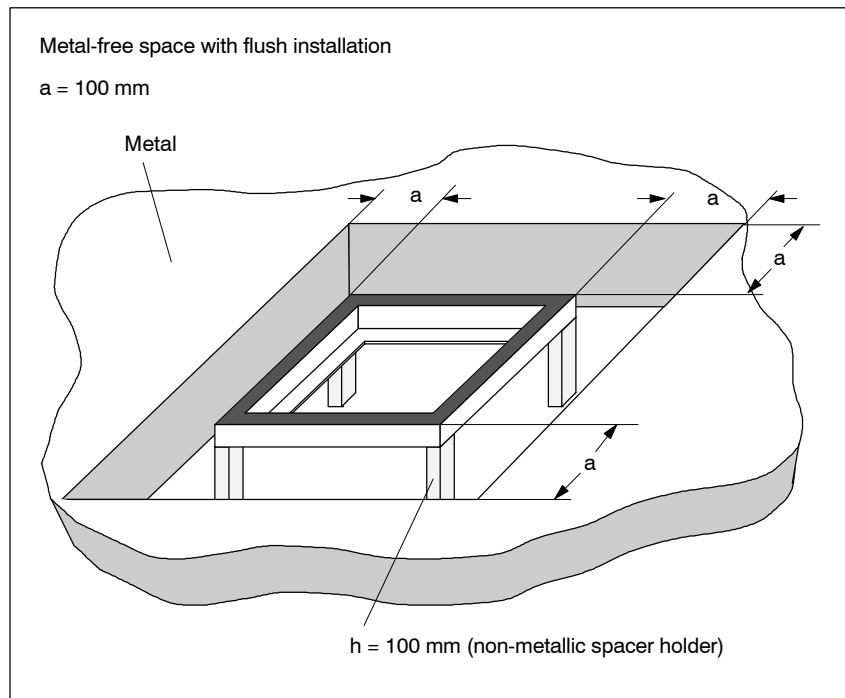

Figure 5-3 Metal-free space for SLG 80 ANT F5

Definition of distance D

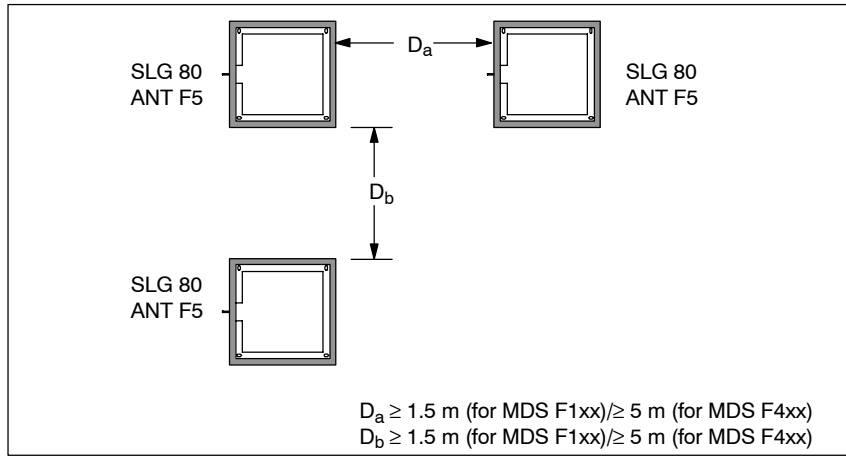

Figure 5-4 Distance D for SLG 80 ANT F5

**Dimensions
(in mm)**

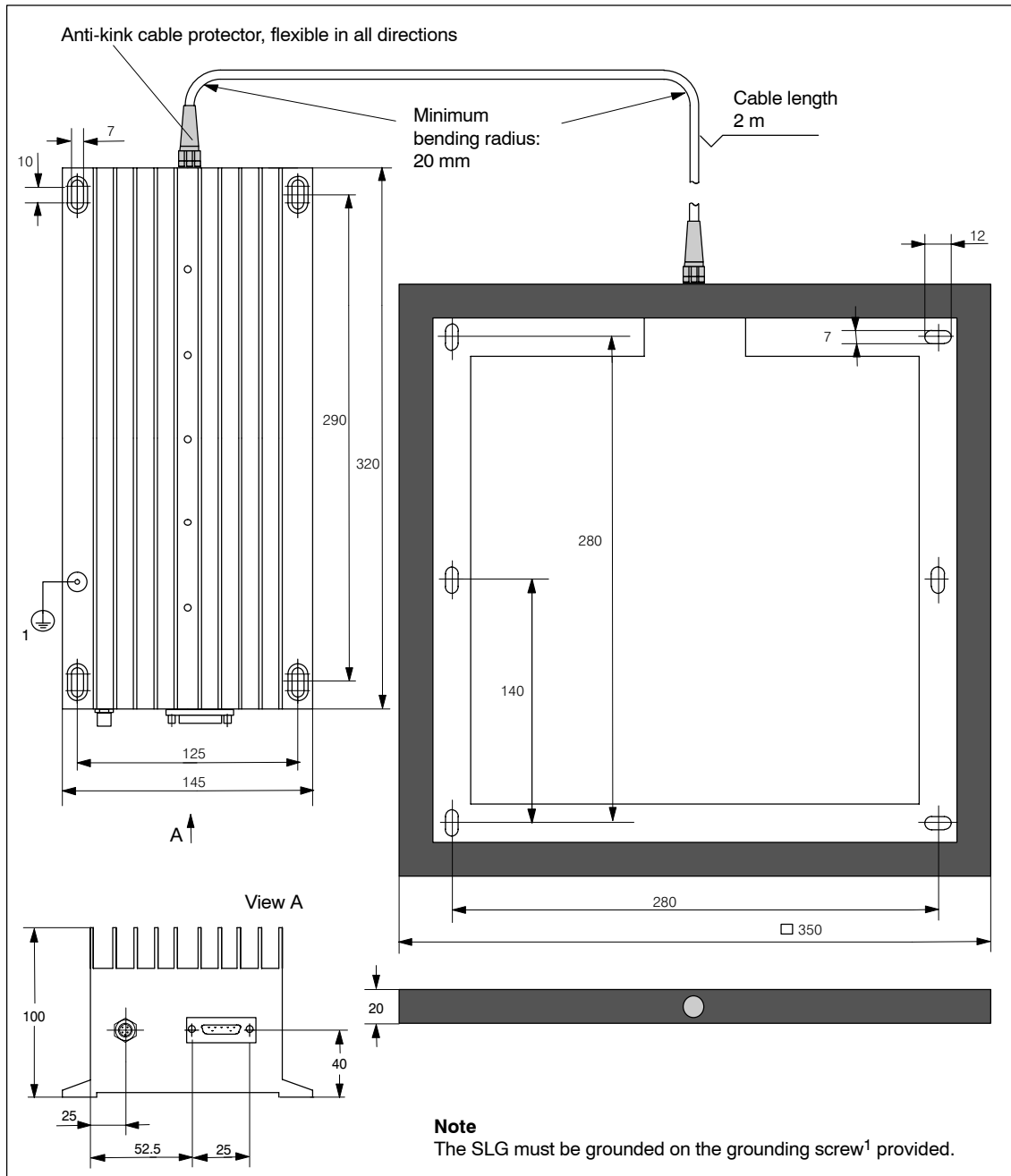

Figure 5-5 Dimensional diagram of SLG 80 ANT F5

Note

To ensure optimal field data even in a metallic environment, the ANT F5 is calibrated at the plant to a distance of 100 mm to metal.

**Spacer kit for
MOBY F ANT F5**

Table 5-5 Ordering data for spacer kit MOBY F ANT F5

	Order No.
Spacer kit for ANT F5 of aluminum with plastic spacers incl. mounting screws	6GT2 690-0AB00
Single Parts	Quantity
Aluminum plate, 380 x 380 x 2	1
Plastic bolts, 100 x 20	4
Countersunk screws, M5 x 12	4
Pan head screws, M5 x 20	4
Washer for M5	4
Spring ring for M5	4

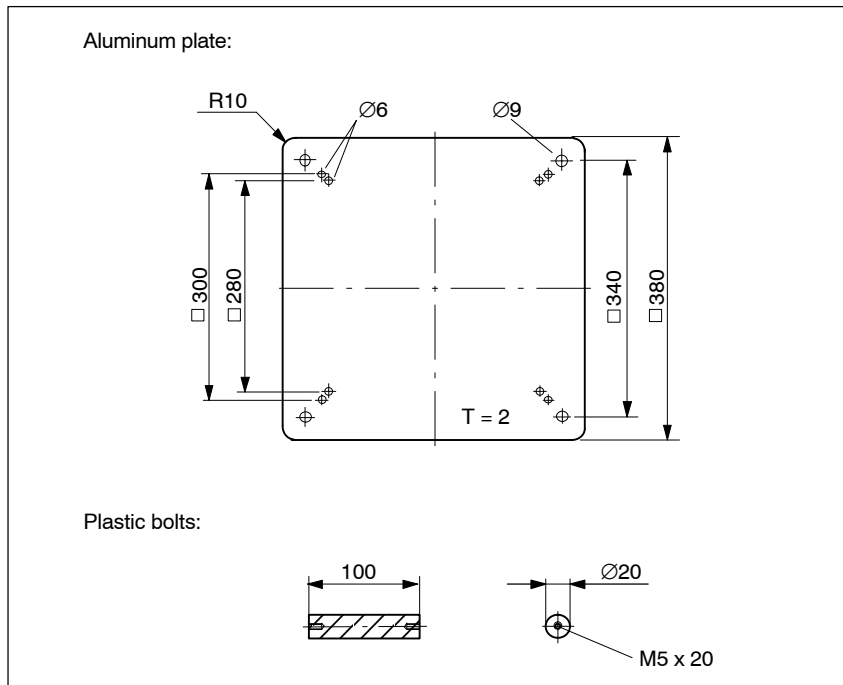

Figure 5-6 Dimensional drawing of the spacer kit for MOBY F ANT F5

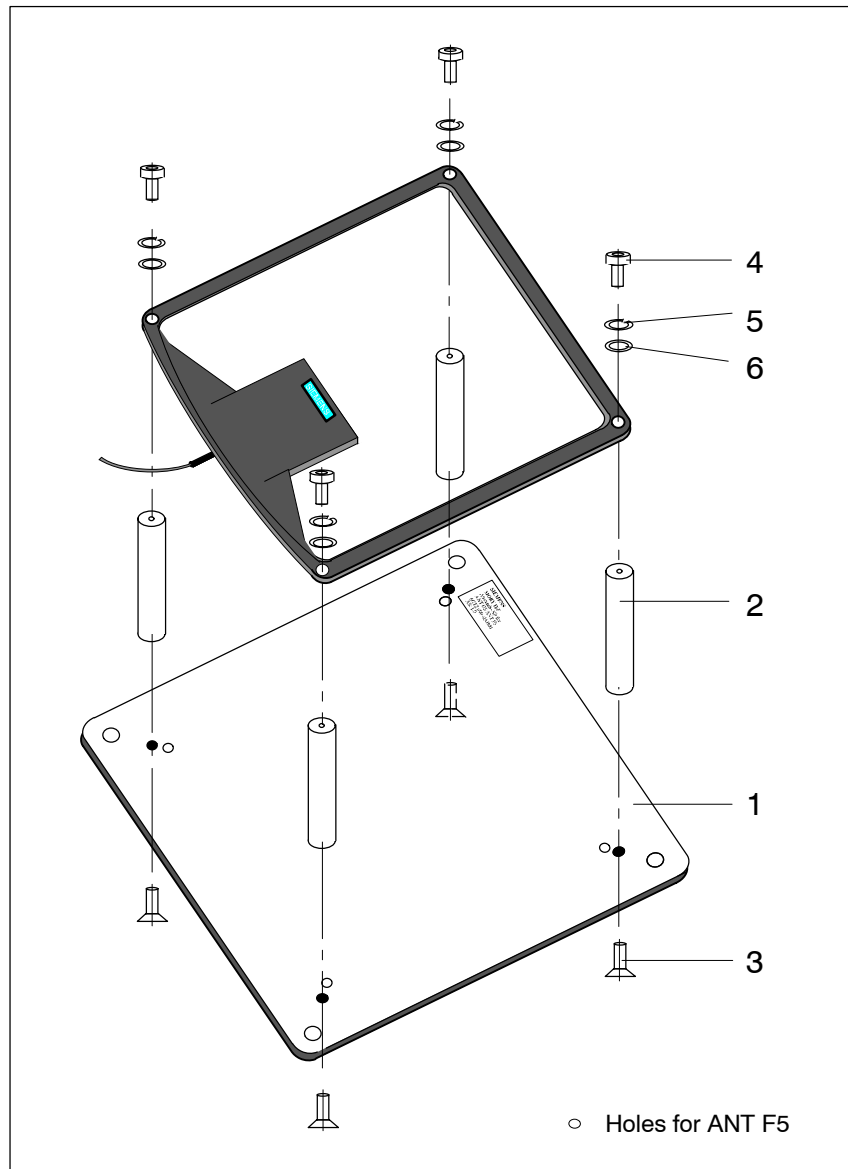

Figure 5-7 Installation drawing for spacer kit

5.3 SLG 82 Basic Device

Application area

The SLG 82 is a basic middle-of-the-line device.
 The SLA 81 and SLA 82 can be connected as antennas. These are not included with the SLG basic device.
 The maximum length of the line between antenna and evaluation unit is 55 m.
 The 5-m connection cable from the antenna to the evaluation unit is not included with the SLG 82 basic device.



Figure 5-8 Read/write, SLG 82 basic device

Ordering data

Table 5-6 Ordering data for the SLG 82 basic device

Read/write SLG 82 basic device with serial interface RS 422, for SLA 81 or SLA 82 (SLA not included) To be operated on the following interfaces: ASM 400, ASM 410, ASM 450, ASM 452, ASM 470, ASM 473 and ASM 475	6GT2 499-1BC00
Accessories: Wide-range power pack, 100 to 230 V AC/ 24 V DC, 2.2 A (without 24 V stub line)	6GT2 494-0AA00
Adapter floor plate for top hat rail mounting Stub lines and accessories	6GT2 390-0BA00 See chap. 3.7.

Technical data

Table 5-7 Technical data of the SLG 82 basic device

Inductive interface to the MDS Read/write distances between SLG and MDS, max. Transmission frequency	Varies with antenna (see field data) 125 kHz
Serial interface to the ASM Data transmission rate Data line length to the ASM, max. Line length to antenna	RS 422 9600 Baud 1000 m Max. of 55 mm (can be connected on both sides)
Supply voltage Nominal value Permissible range Current consumption Power-on current, brief Operation (at 24 V DC)	Via separate power plug (not included, see accessories) 24 V DC 20 to 30 V DC Max. of 1.1 A 250 mA, typical
MTBF (at +40 °C)	1 x 10 ⁵ hours
Housing Dimensions (in mm) Electronics without plug (L x W x H) Color Material Plug connection Data (RS 422) Electronics ↔ antenna Supply voltage	205 x 130 x 60 Anthracite Aluminum 9-pin, submin D plug (pins on device side) 9-pin submin D plug (socket on device side) 4-pin M12 on SLG housing (pin)
Protection rating in acc. w. EN 60529 Shock in acc. w. EN 60721-3-7/class 7M2 Total shock-response spectrum, type II Vibration in acc. w. EN 60721-3-7/ class 7M2	IP40 (higher protection ratings on request) 30 g 1 g (9 to 200 Hz) 1.5 g (200 to 500 Hz)
Mounting of the SLG Tightening moment at 20 °C	4 M5 screws ≤ 3 Nm
Ambient temperature Operation Transportation and storage	–25° C to +55° C (no condensation) –40° C to +85° C (no condensation)
Weight (without connection cable)	1300 g

Pin allocations and switches

An SLA 81 or SLA 82 can be connected to the SLG 82 basic device.

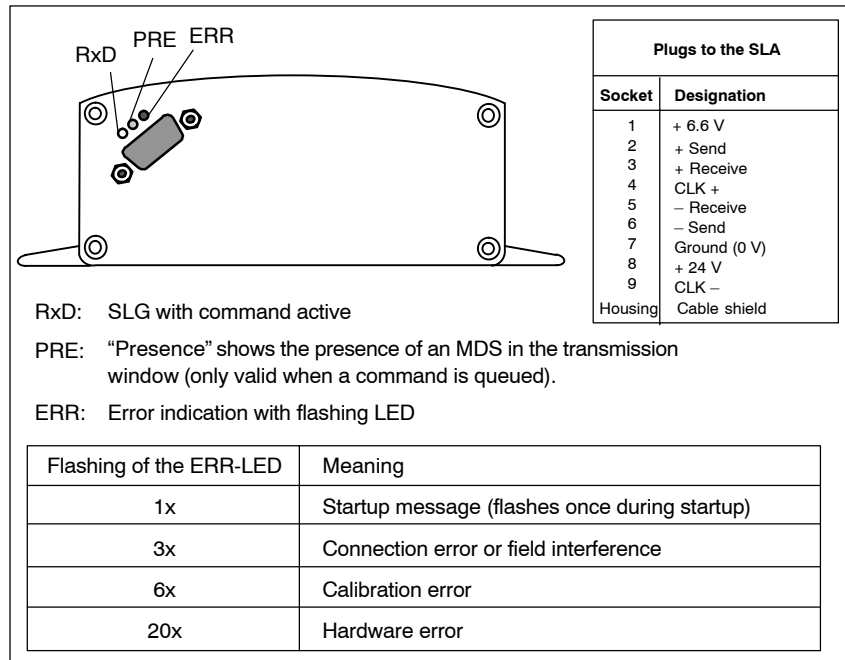

Figure 5-9 Serial interface of the SLG 82 basic device to the SLA

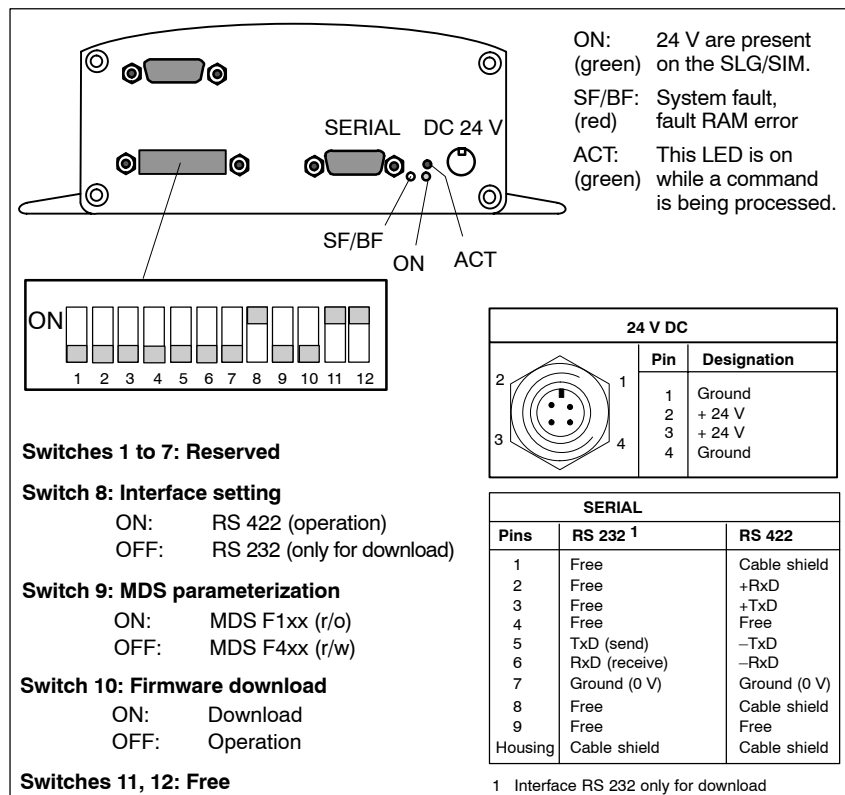

Figure 5-10 Serial interfaces of the SLG 82 basic device to the user

**Dimensions
(in mm)**

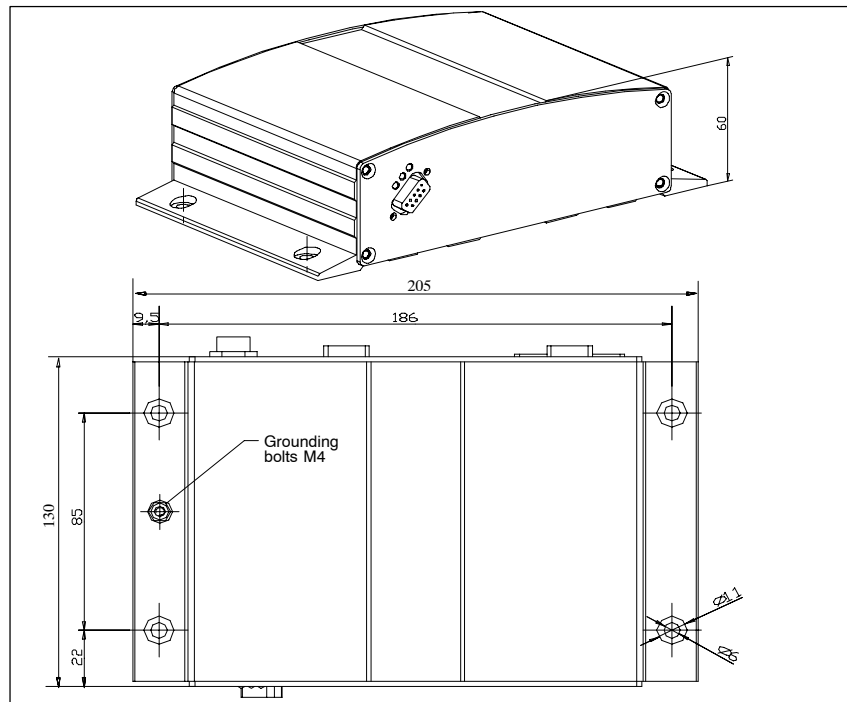

Figure 5-11 Dimensional drawing of SLG 82 basic device without mounting holes

**Adapter floor plate
for top hat rail
mounting**

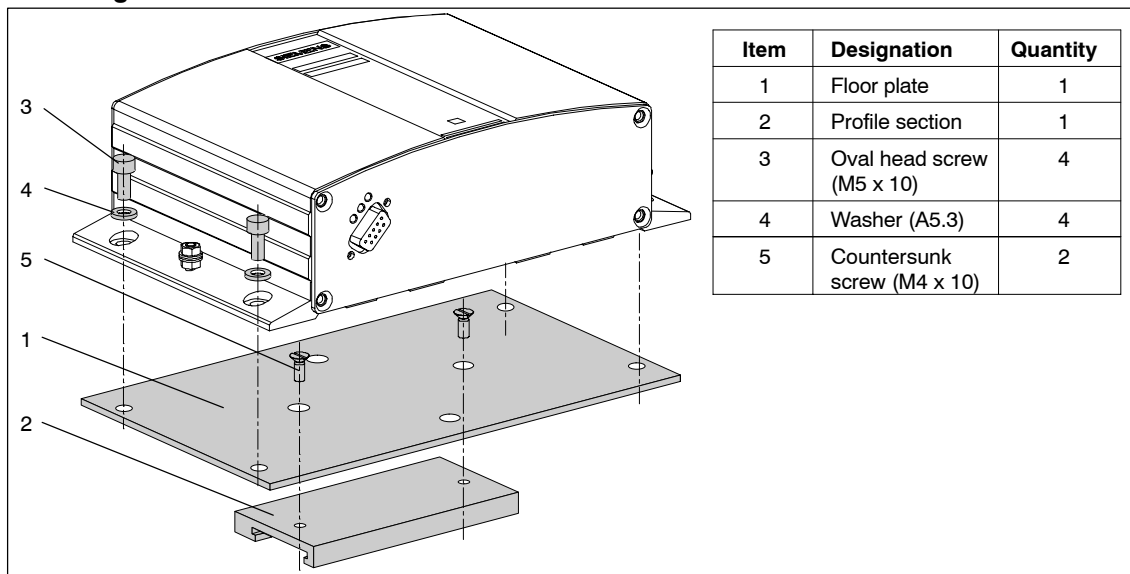

Figure 5-12 Mounting drawing of the adapter floor plate

Note

The profile section (item 2) can be turned by 90° on the floor plate to adjust to the concrete mounting conditions.

5.4 SLG 82

Application area

The SLG 82 is a medium-end, read/write device with a remote antenna. The cable between antenna and evaluation unit may be up to 55 m in length. The antenna head can be positioned very precisely for every application with two screw nuts. Mixed operation in systems with the SLG 80 is possible (but without DSP/FFT command). The connection cable from the antenna to the evaluation unit is included with the SLG 82 (length: 5 m).



Figure 5-13 Read/write device SLG 82

Ordering data

Table 5-8 Ordering data of the SLG 82

SLG 82 read/write device with serial interface RS 422 and an SLA 81	6GT2 401-2CB00
Adapter floor plate for top hat rail mounting for SLG 82	6GT2 390-0BA00
Stub lines and accessories	See chap. 3.7.

Technical data

Table 5-9 Technical data of the SLG 82

Inductive interface to the MDS	
Max. SLG-MDS read/write distances	140 mm (see field data)
Transmission frequency	125 kHz
Serial interface to the ASM	RS 422
Data transmission speed	9600 baud
Data line length to ASM (max.)	1000 m
Line length to the antenna	Max. of 55 m (can be plugged on both sides)

Table 5-9 Technical data of the SLG 82

Voltage supply	With separate power plug (not included with the SLG 82)
Nominal value	24 V DC
Permissible range	20 to 30 V DC
Current consumption	
Switch-on current (brief)	Max. of 1.1 A
Operation (at 24 V DC)	250 mA (typical)
MTBF (at +40° C)	1 x 10 ⁵ hours
Housing	
Dimensions (in mm)	
Antenna with threading and plug (Ø x L)	65 x 90
Threading on plug side (Ø x incline x L)	M30 x 1.5 x 40
Electronics without plug (L x W x H)	205 x 130 x 60
Color (antenna)	Anthracite/pastel turquoise
(SLG housing)	Anthracite
Material (antenna)	Krastin
(SLG-Gehäuse)	Aluminum
Plug connection	
Data (RS 422)	9-pole, submin. D plug (pins on device side)
Electronics ↔ antenna	9-pole, submin. D plug (socket on device side)
Voltage supply	4-pole, M12 on SLG housing (pin)
Protection rating in acc. w. EN 60529	
SLG housing	IP40 (higher protection rating on request)
Antenna	IP65
Shock in acc. w. EN 60721-3-7/class 7M2	30 g
Total shock-response range, type II	
Vibration in acc. w. EN 60721-3-7/class 7M2	1 g (9 to 200 Hz) 1.5 g (200 to 500 Hz)
Mounting of SLG	4 M5 screws
Tightening moment at 20° C	≤ 3 Nm
Mounting of antenna	2 plastic nuts (M30 x 1.5)
Ambient temperature	
Antenna Operation	-25° C to +70° C
Transportation and storage	-40° C to +85° C
SLG housing Operation	-25° C to +55° C
Transportation and storage	(no condensation) -40° C to +85° C (no condensation)
Weight (without connection cable)	
SLG	1300 g
Antenna	150 g

Field data

Table 5-10 Field data of SLG 82

Working distance (S_a)	0 to 110 mm
Limit distance (S_g)	140 mm
Diameter of transmission window (L_d)	70 mm
Minimum distance from SLA to SLA (D)	See figure 5-16.

Transmission window

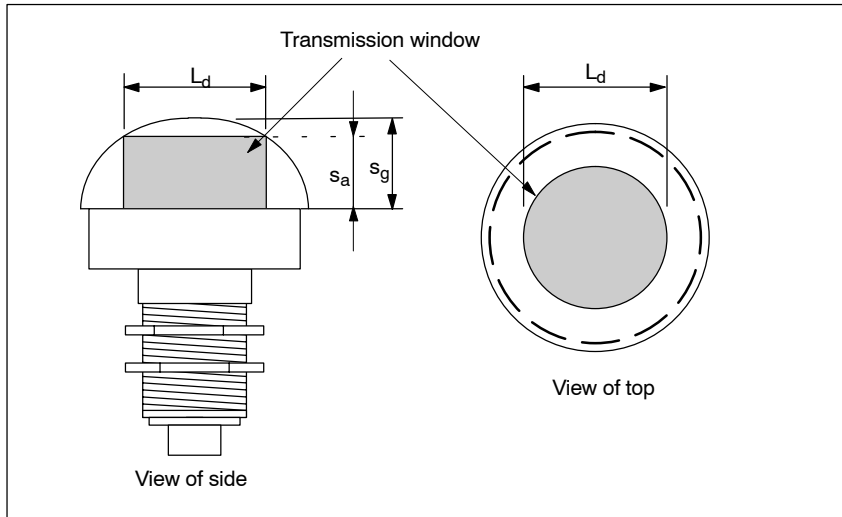

Figure 5-14 Transmission window of SLG 82 with SLA 81

Metal-free space

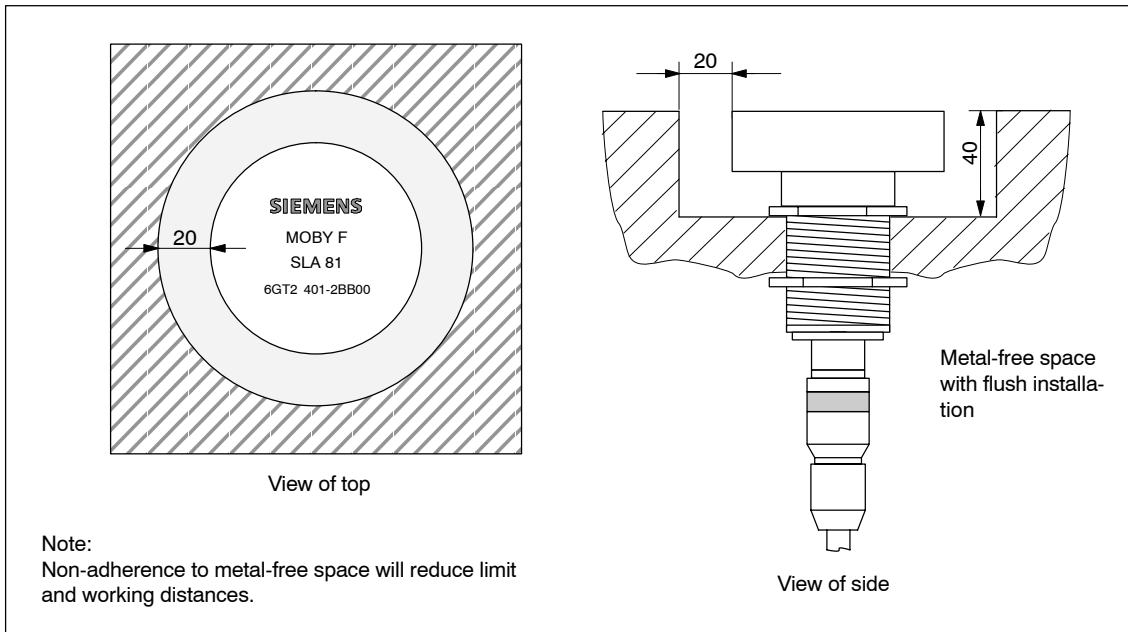

Figure 5-15 Metal-free space for SLG 82 with SLA 81

Definition of distance D

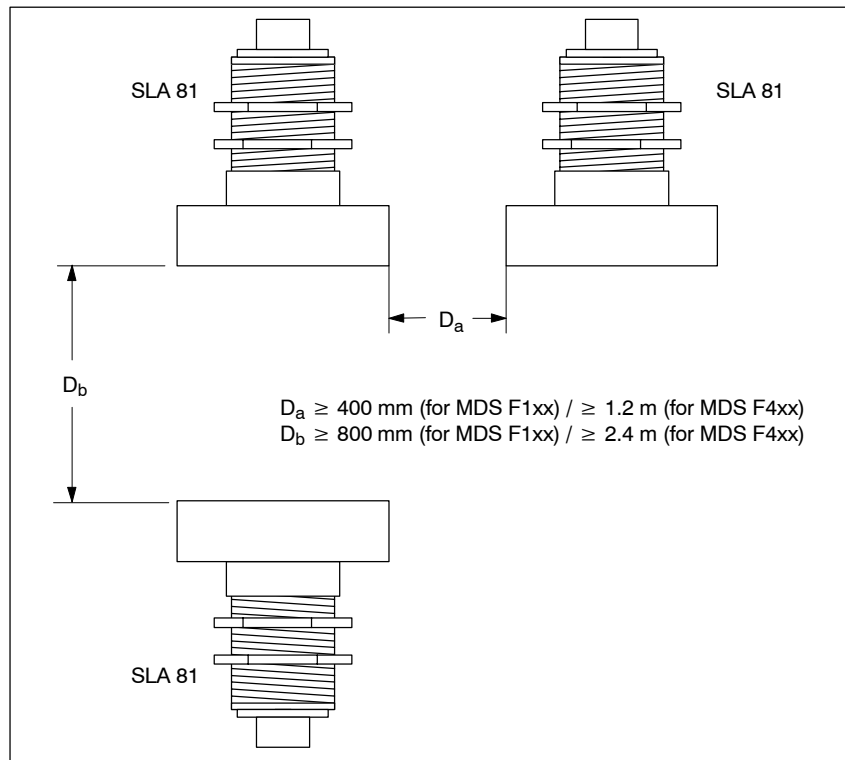

Figure 5-16 Distance D: SLG 82

Pin allocations and switches

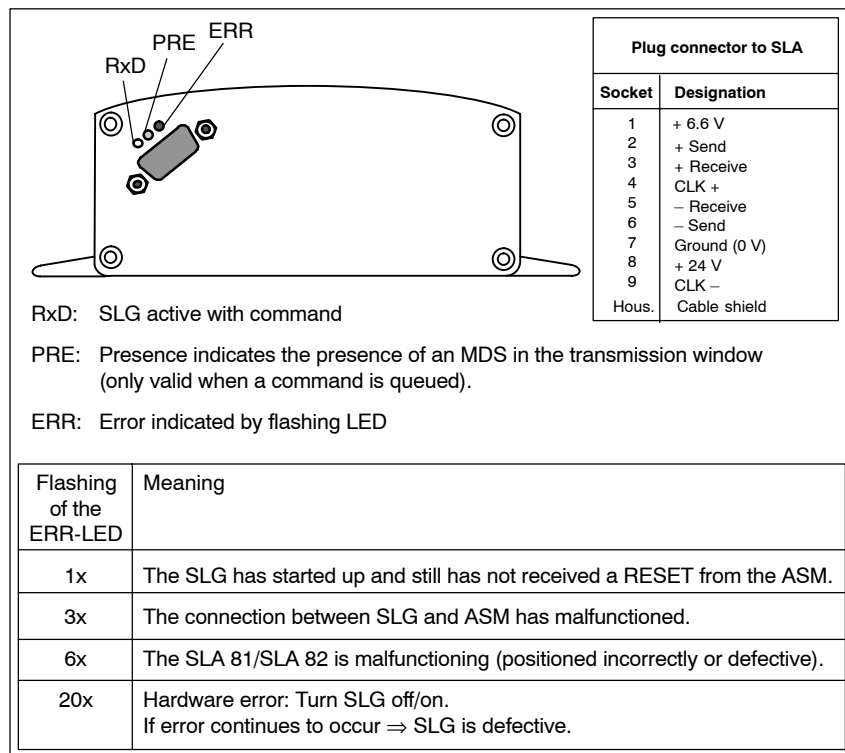

Figure 5-17 Serial interface of SLG 82 to SLA 81

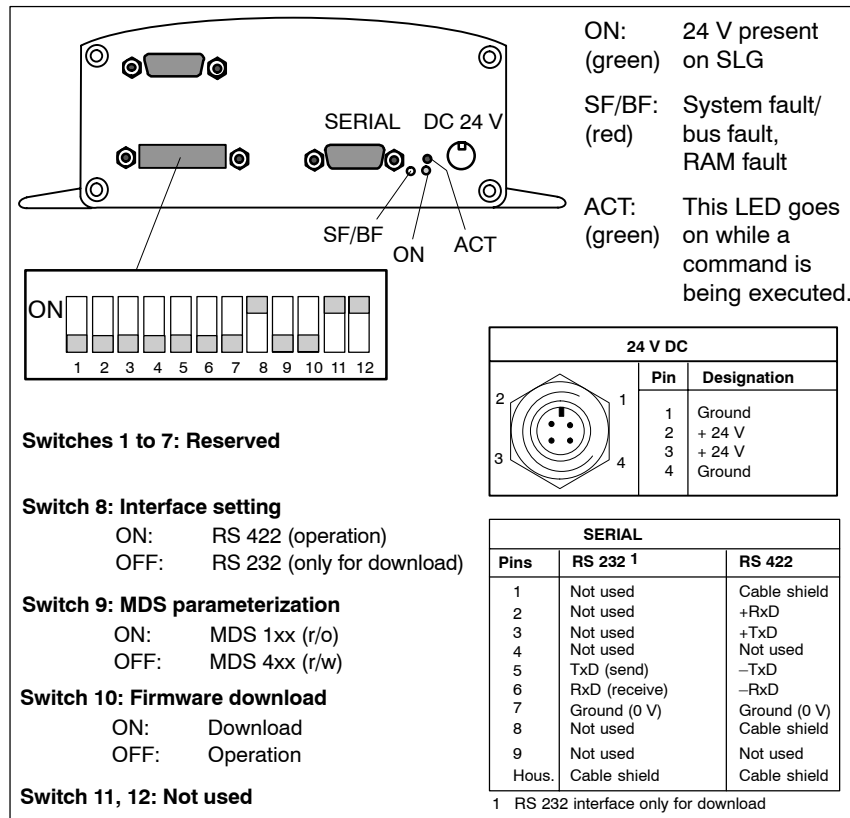

Figure 5-18 Serial interface of SLG 82 to user

Dimensions (in mm)

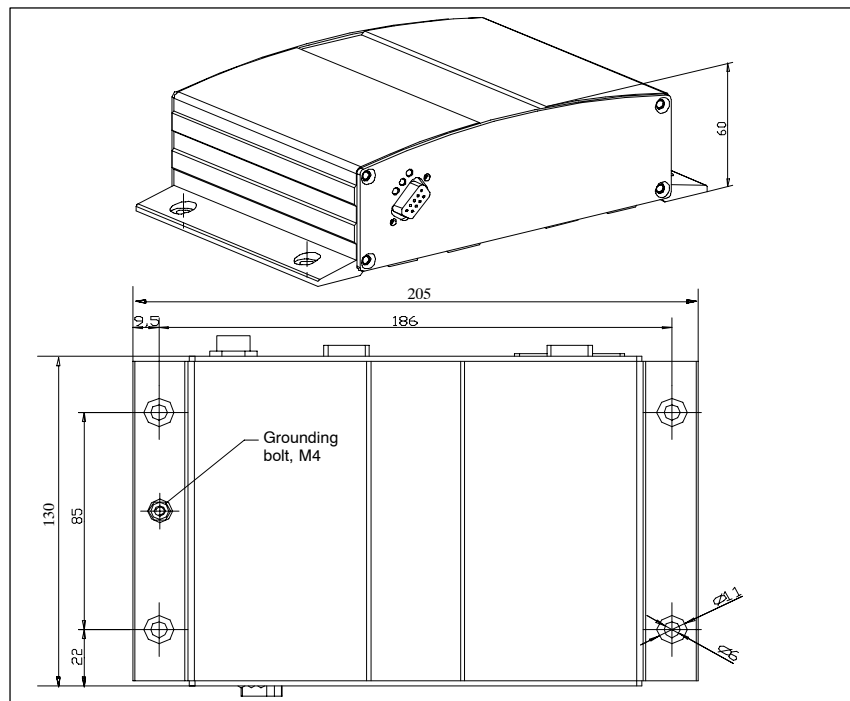

Figure 5-19 Drawing of SLG 82's housing

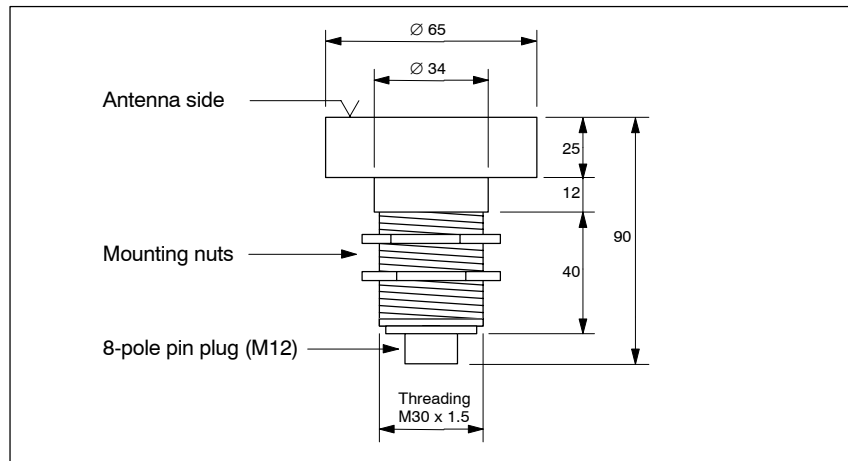

Figure 5-20 Drawing of antenna for SLG 82 (SLA 81)

**Adapter floor plate
for top hat rail
mounting**

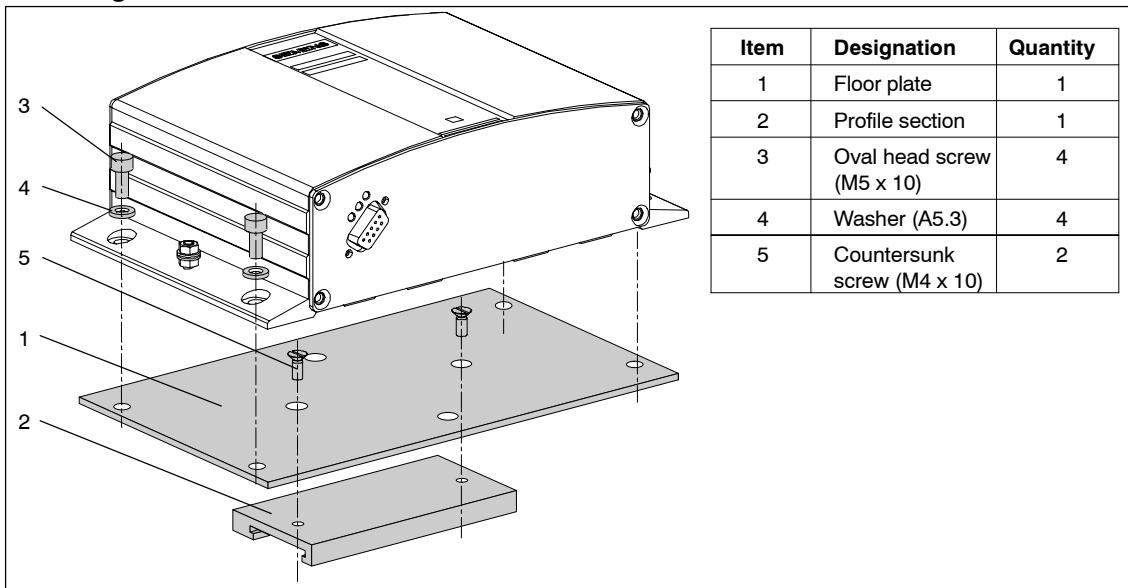

Figure 5-21 Drawing of mounting of adapter floor plate

Note

The profile section (item 2) can be turned by 90° and mounted to allow for adjustment to the actual situation.

5.5 SLA 81

Application area

The SLA 81 is a read/write device in the medium performance range. It permits greater distances to the evaluation unit (SLG, SIM or ASM). The cable between antenna and evaluation unit may be up to 55 m in length. The antenna head can be positioned very precisely for every application with two screw nuts.

The SLA 81 is used with the following components: SLG 82, SIM 82, ASM 824, ASM 850 and ASM 854.



Figure 5-22 Read/write device SLA 81

Ordering data

Table 5-11 Ordering data of the SLA 81

SLA 81 read/write antenna	6GT2 401-2BB00
Mounting clamp for SLA 81	3SX6 284
Stub lines and accessories	See chap. 3.7.

Technical data

Table 5-12 Technical data of the SLA 81

Inductive interface to the MDS	
Max. SLG/SIM/ASM-MDS read/write distances	140 mm (see field data)
Transmission frequency	125 kHz
Serial interface to the evaluation unit	RS 422
Data transmission speed (SLA – evaluation unit)	2 kbaud (gross)
Data line length to SLG/SIM/ASM (max.)	55 m

Table 5-12 Technical data of the SLA 81

Voltage supply (only via evaluation unit)	6.6 V DC
Current consumption at room temperature	180 mA (typical)
Antenna Dimensions (in mm) Antenna with threading and plug (\varnothing x L) Threading on plug side (\varnothing x incline x L) Color Material Plug connection Standard connection cable to evaluation unit	65 x 90 M30 x 1.5 x 40 Pastel turquoise Krastin 8-pole M12 plug (pin on device side) 5 m
Protection rating in acc. w. EN 60529 Shock in acc. w. EN 60721-3-7/class 7M2 Total shock-response range, type II Vibration in acc. w. EN 60721-3-7/class 7M2	IP65 30 g 2 g (3 to 200 Hz) 5 g (200 to 500 Hz)
Mounting of SLA 81	2 plastic nuts (M30 x 1.5)
Ambient temperature Operation Transportation and storage	-25° C to +70° C -40° C to +85° C
Weight (without connection cable)	150 g

Field data

Table 5-13 Field data of SLA 81

Working distance (S_a)	0 to 110 mm
Limit distance (S_g)	140 mm
Diameter of transmission window (L_d)	70 mm
Minimum distance from SLA to SLA (D)	See figure 5-25

Transmission window

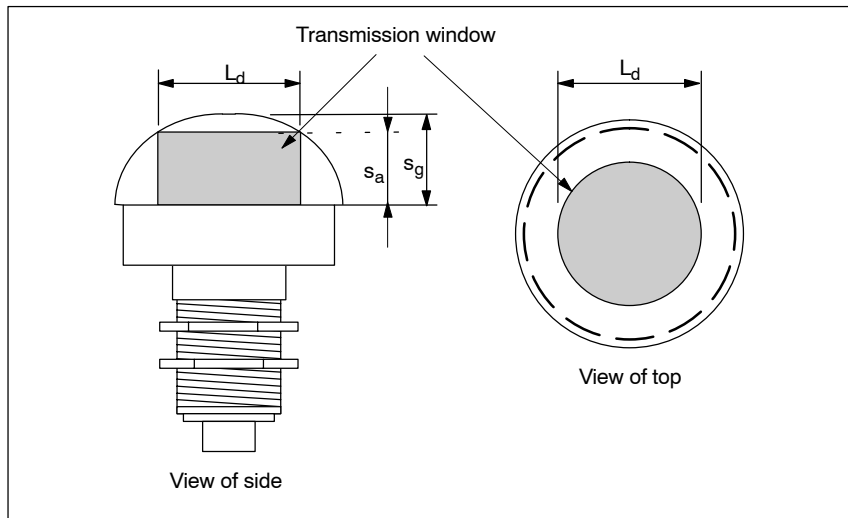

Figure 5-23 Transmission window of SLA 81

Metal-free space

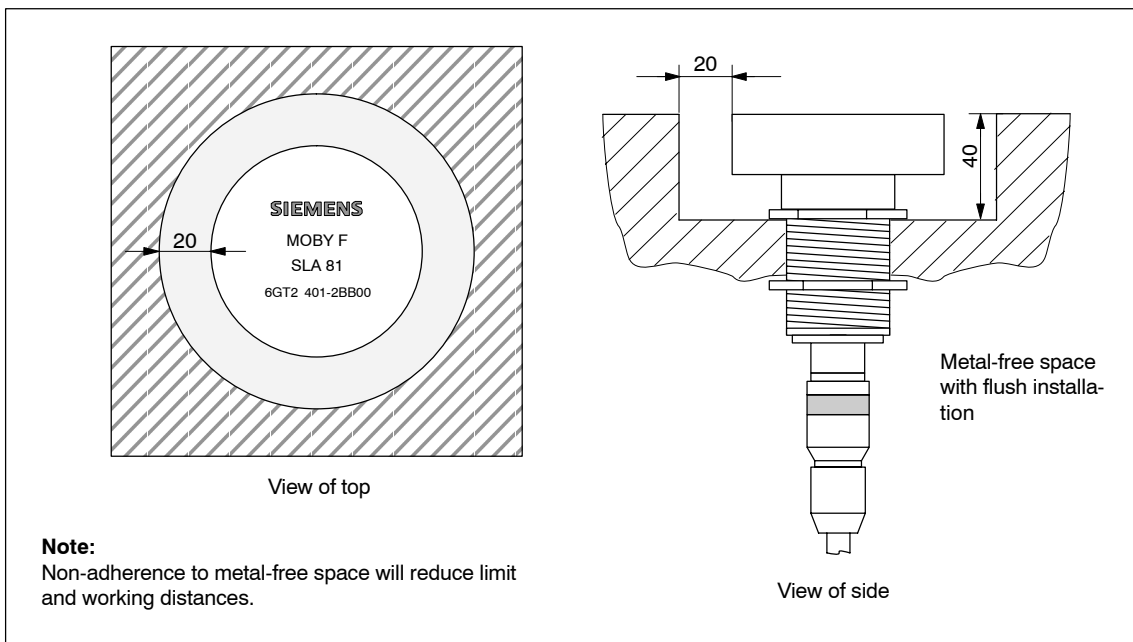

Figure 5-24 Metal-free space for SLA 81

Definition of distance D

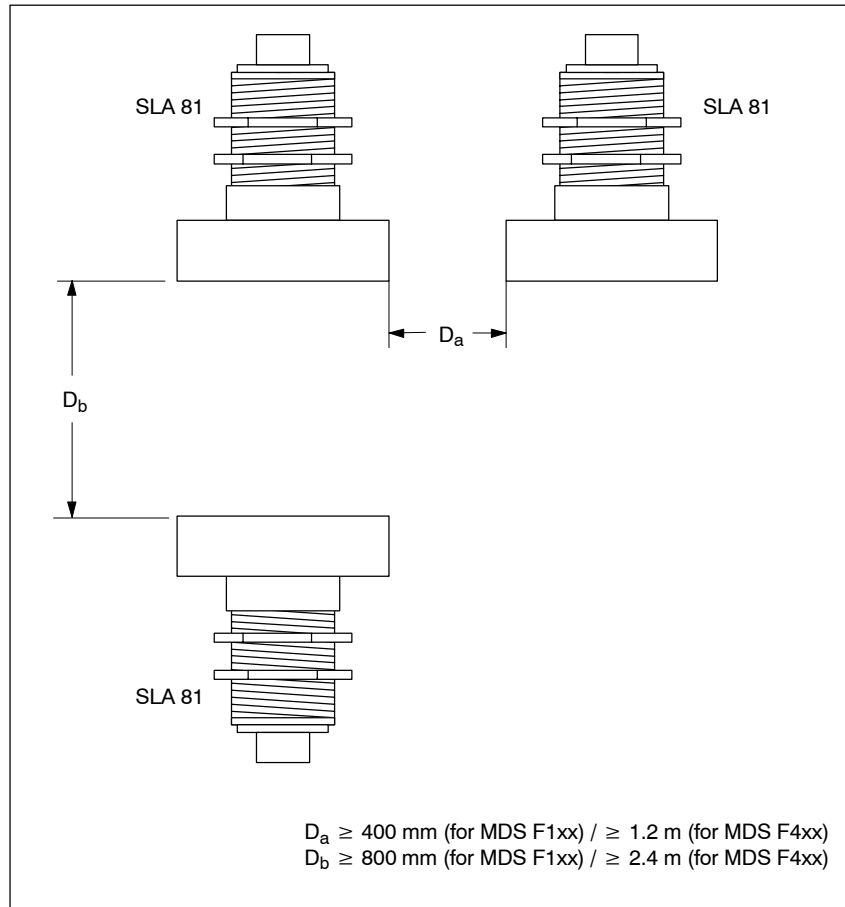

Figure 5-25 Distance D: SLA 81

Dimensions (in mm)

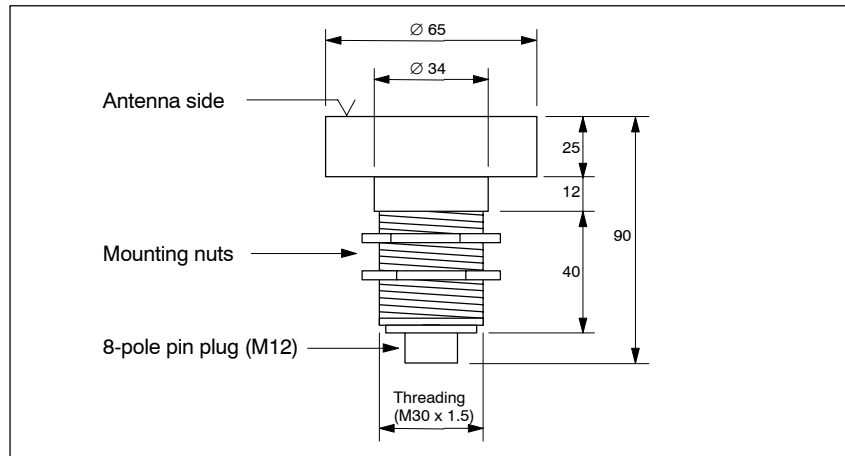

Figure 5-26 Dimensional drawing of SLA 81

Optional mounting clamp

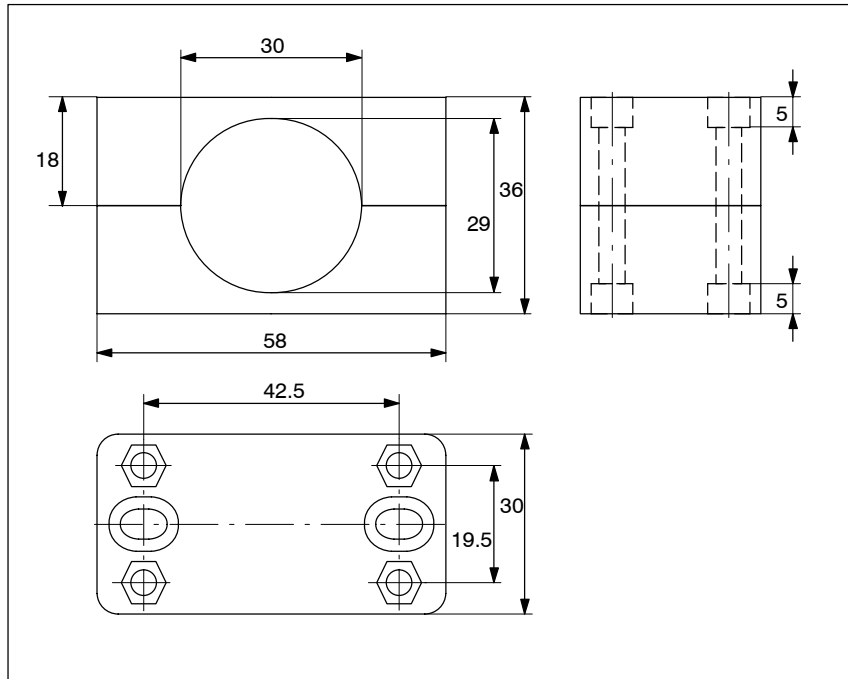

Figure 5-27 Dimensional drawing of the mounting clamp

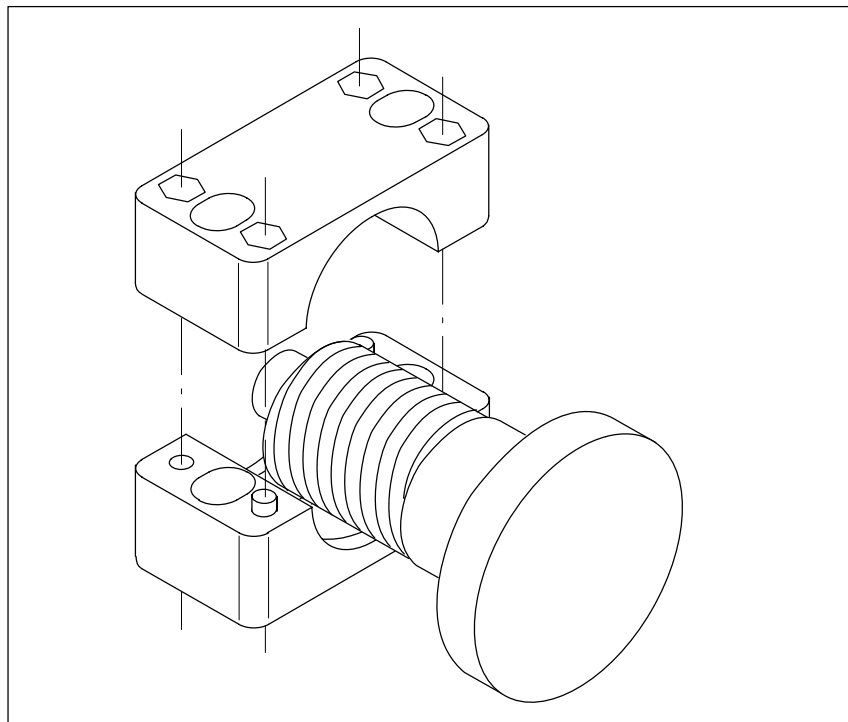

Figure 5-28 Drawing of mounting of SLA 81 with mounting clamp

5.6 SLA 82

Application area

The SLA 82 is a middle-of-the-line read/write antenna. It permits a greater distance to the evaluation unit (SLG, SIM or ASM). The maximum line length between antenna and evaluation unit is 55 m. The SLG 82 can be connected to the following components: SLG 82 basic device, SIM 82, ASM 824, ASM 850 and ASM 854.

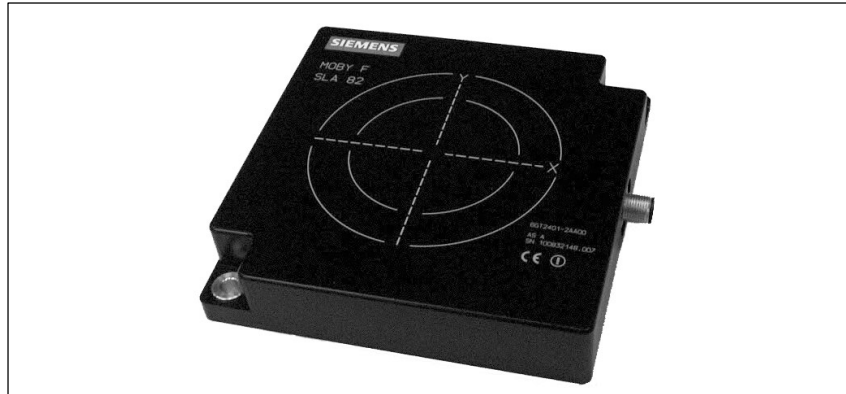

Figure 5-29 SLA 82 read/write antenna

Ordering data

Table 5-14 Ordering data of the SLA 82

SLA 82 read/write antenna	6GT2 401-2AA00
Stub lines and accessories	See chap. 3.7.

Technical data

Table 5-15 Technical data of the SLA 82

Inductive interface to the MDS	
Max. read/write distances between SLG and MDS	200 mm (see field data)
Transmission frequency	125 kHz
Serial interface to the evaluation unit	RS 422
Data transmission rate (SLA – evaluation unit)	2 kBaud (gross)
Max. data line length to the ASM	55 m
Supply voltage (only via evaluation unit)	6.6 V DC
Current consumption at room temperature	180 mA, typical

Table 5-15 Technical data of the SLA 82

Antenna	
Dimensions without plug (L x W x H in mm)	150 x 150 x 30
Color	Anthracite
Material	Plastic, PA 12
Plug connection	8-pin, M12 plug (pin on the device side)
Standard connection cable to the evaluation unit (see accessories)	5 m
Protection rating in acc. w. EN 60529	IP65
Shock in acc. w. EN 60721-3-7/class 7M2	30 g
Total shock-response spectrum, type II	
Vibration in acc. w. EN 60721-3-7/class 7M2	2 g (3 to 200 Hz) 5 g (200 to 500 Hz)
Mounting of the SLA 82	2 M6 screws
Ambient temperature	
Operation	-25 °C to +70 °C
Transportation and storage	-40 °C to +85 °C
Weight without connection cable, approx.	500 g

Field data

Table 5-16 Field data of the SLA 82

Working distance (S _a)	0 to 180 mm
Limit distance (S _g)	200 mm
Diameter of the transmission field (L _d)	120 mm
Minimum distance from SLA to SLA (D)	See figure 5-32.

Transmission window

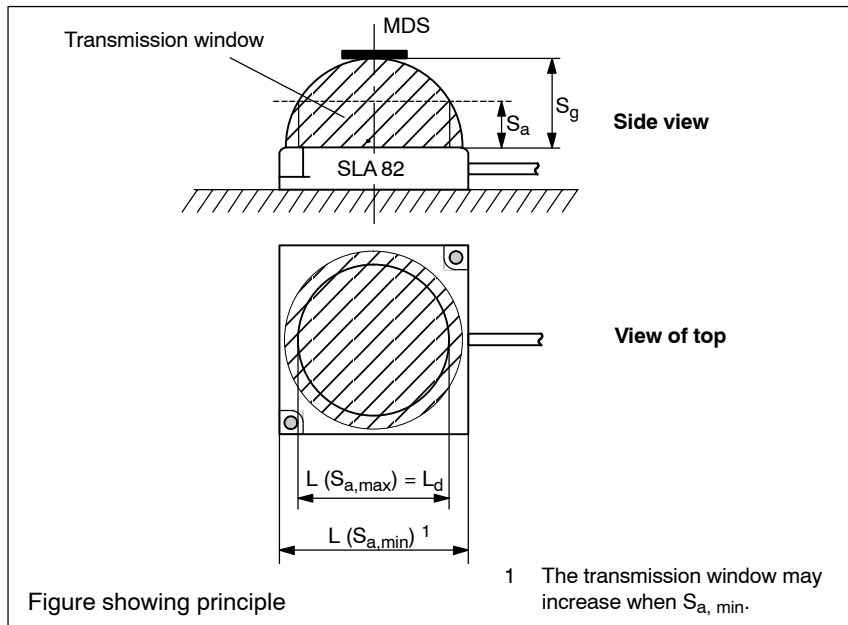

Figure 5-30 Transmission window of the SLA 82

Metal-free space

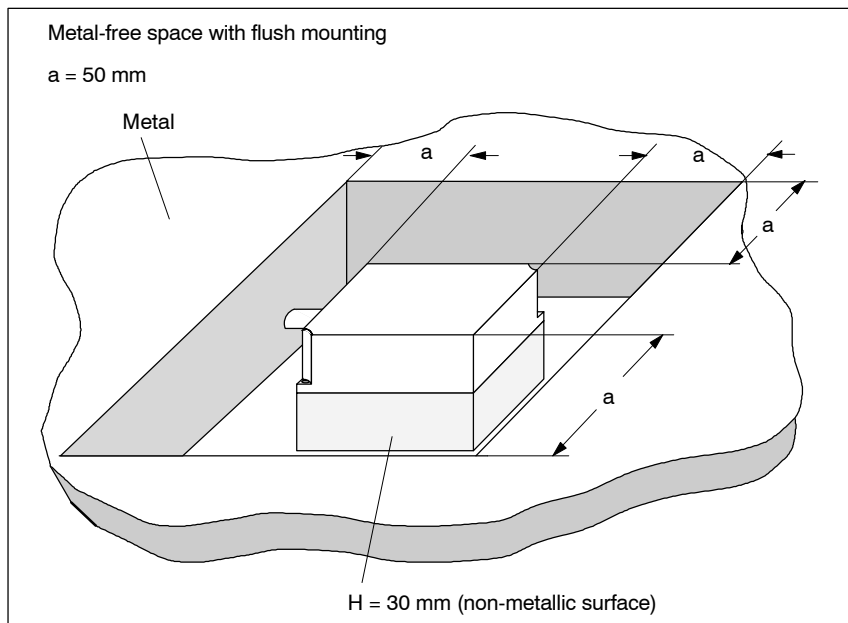

Figure 5-31 Metal-free area of SLA 82

Definition of the distance D

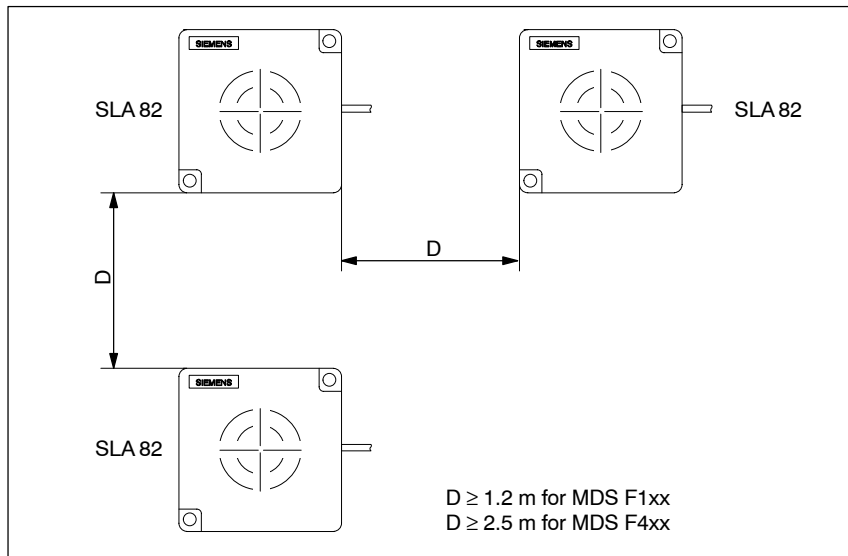

Figure 5-32 Distance D: SLA 82

Dimensions (in mm)

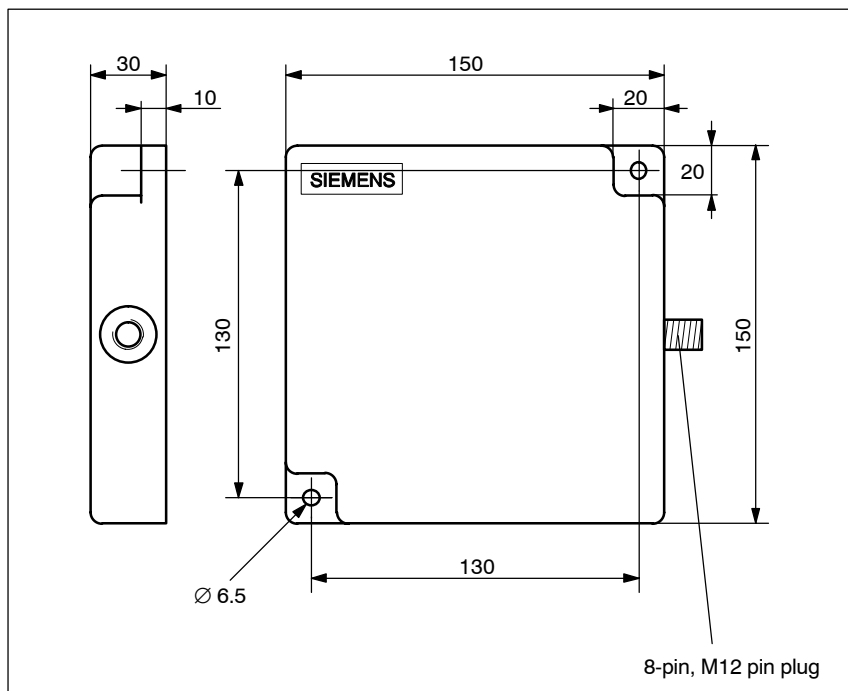

Figure 5-33 Dimensional drawing of SLA 82

Interfaces

6

6.1 Introduction

Application area ASM interfaces provide the link between MOBY E components (i.e., SLG/SLA/MDS) and higher level controllers (e.g., SIMATIC S5/S7), PCs or computers. Up to four SLGs/SLAs can be connected depending on the interface used.

Layout and functions An ASM consists of a microcontroller system with its own program stored on a PROM. The CPU receives commands via the user interface and stores these in the RAM. The user receives an acknowledgment that the command has arrived. When the command is correct, the CPU begins execution.

Overview

Table 6-1 Overview of the interfaces

ASM Type	Interfaces to PC/Computer	Interfaces to SLG/SLA	Function Blocks	SLG/SLA Connections	Dimensions (WxHxD in mm)	Temperature Range (During Operation)	Protection Rating
ASM 400	Can be installed in S5-115-155U	9-pole sub D socket	FB 250/230/252	1 per CM 4 per ASM		0° to +55° C	IP00
ASM 410	Can be installed in S5-100U/ET 200U	Can be connected via bus module		2 (multiplex)	45 x 135 x 100	0° to +60° C	IP20
ASM 450	To PROFIBUS DP (screw connection)	2x5-pole prox. switch plug connectors	FC 45 FC 46 FB 240	2 (multiplex)	134 x 110 x 55	0° to +55° C	IP65
ASM 452	PROFIBUS DPV1	2x5-pole prox. switch plug	FC 45	2 (quasi-parallel)	134 x 110 x 55	0° to +55° C	IP67
ASM 470	Can be installed in S7-300/ET 200M	Via screw terminals	FC 47 FB 47	2 (multiplex)	45 x 125 x 120	0° to +60° C	IP20
ASM 473	Can be plugged into ET 200X	2x5-pole prox. switch plug	FC 45	1	87 x 110 x 55	0° to +55° C	IP67
ASM 475	Can be plugged into S7-300/ET 200M	via screw-type terminals	FC 45	2 (parallel)	40 x 125 x 120	0° to +60° C	IP20
ASM 824	RS 232/422 9-pole sub D socket	9-pole sub D socket	MOBY API (DLL)	4 x SLA 8x (parallel)	205 x 130 x 60	-25° to +55° C	IP40

Table 6-1 Overview of the interfaces

ASM Type	Interfaces to PC/Computer	Interfaces to SLG/SLA	Function Blocks	SLG/SLA Connections	Dimensions (WxHxD in mm)	Temperature Range (During Operation)	Protection Rating
ASM 850	PROFIBUS DPV1 9-pole sub D socket	9-pole sub D socket	FC 45	1 x SLA 8x	205 x 130 x 60	-25° to +55° C	IP40
ASM 854	PROFIBUS DPV1 9-pole sub D socket	9-pole sub D socket	FC 45	4 x SLA 8x (parallel)	205 x 130 x 60	-25° to +55° C	IP40
SIM 80 ANT F5	RS 232 9-pole sub D plug connector	Integrated	C-Lib (DLL)	–	320 x 145 x 100 350 x 350 x 20	-25° to + 60° C	IP65
SIM 82	RS 232/422 9-pole sub D socket	9-pole sub D socket	C-Lib (DLL)	1 x SLA 8x	205 x 130 x 60	-25° to +55° C	IP40

6.2 ASM 400

6.2.1 Overview

Application area ASM 400 interfaces can be directly installed and operated in the following SIMATIC S5 programmable controllers.

- S5-155U/F (all CPUs)
- S5-135U (all CPUs)
- S5-155U/H (all CPUs)

Layout and function

ASM 400 interfaces consist of the basic module in double Europe format and the CM 422 channel submodule. The basic module can be equipped with one to four channel submodules. Mixed configuration is not permitted.

The ASM 400 with the CM 422 operates in the I/O area of the SIMATIC S5. When used with function block FB 250, up to 32 channel submodules (i.e., eight 4-channel interfaces) can be operated in one SIMATIC. When FB 252 is used, the maximum number of channel submodules is increased from 32 to 96 per SIMATIC S5. All MDS models can be processed via the FBs. The user addresses the data on the MDS via a command table in the data block. The user addresses user data via absolute addresses.

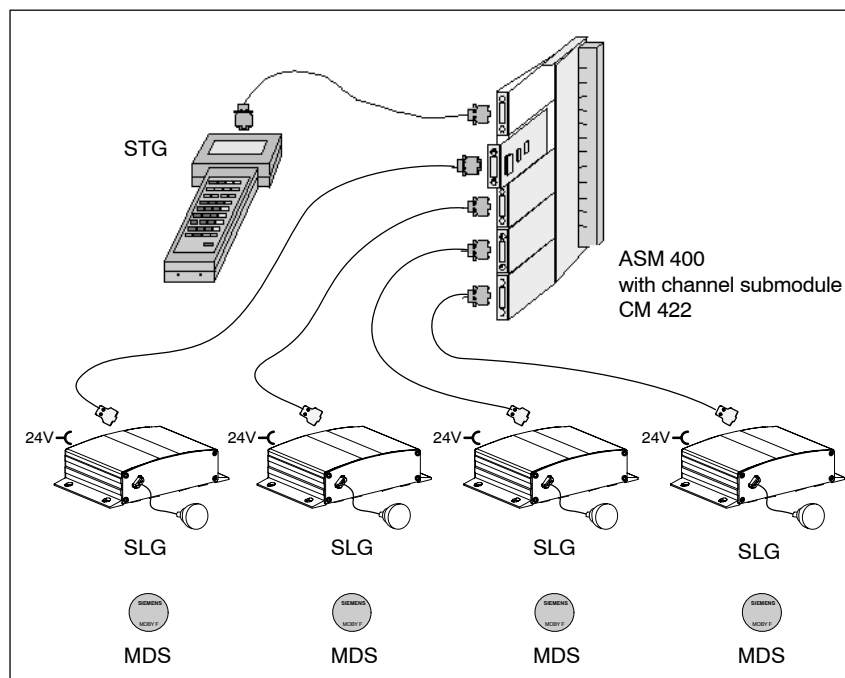

Figure 6-1 Configurator of ASM 400

Communication between ASM 400 and user program

Communication time between ASM 400 and user depends on two factors.

- Cycle time and type of programmable controller
- Software used (i.e., FB 250)

Communication between ASM 400 and user can be divided into three steps.

- The user issues a command and starts it. The next time the FB is called, the command is transferred to the ASM and acknowledged by the ASM.
- The ASM executes the command with the MDS. The user and the FB are in wait status. Data communication with the MDS begins as soon as an MDS enters the transmission window of the SLG. The MDS data are stored intermediately on the ASM and checked for correctness.
- ASM communication with the MDS is concluded. When the FB is called the next time, the data which have been read or written are transferred from the ASM to the user. The user receives a finished message.

Ordering data

Table 6-2 Ordering data of ASM 400

	Order No.
ASM 400 interface consisting of basic module and CM 422 channel module	
Basic module with connection to STG, with 4 slide-in slots for CM 422 channel module, without channel module	6GT2 002-0AA00
CM 422 channel module for an ASM 400, with connection for 1 SLG	6GT2 002-0AB00
MOBY software ¹ Plug, ASM-side, 9-pole, submin D plug (pins) with screw lock for stub line between an ASM 400 and SLG	6GT2 080-2AA10
• 1 each	6GT2 090-0BB00
• 1 package (10 each)	6GT2 090-0BB10
Stub lines and accessories	See chapter 3.7.
Description of ASM 400/401 German English	Electronically available on "Software MOBY" CD
Description of FB 250 for ASM 400 German English	Electronically available on "Software MOBY" CD

¹ See chapter 7.1.

Technical data

Table 6-3 Technical data of ASM 400

Channel Submodule	CM 422	
Serial interface to SLG	RS 422	
Plug connector	9-pole sub D socket	
Max. interface/line length connectable SLG	RS 422/1000 m, depending on SLG type 1 SLG for each CM	
Software functions		
Programming	With STEP 5 function block FB 250	
Commands	Read data, write data, initialize MD Access directly via addresses	
Supply voltage	DC 5/24 V via internal bus	
Interfaces	ASM 400	
Interfaces for CM/SLG		
ASM 400 (max.)	4 CM 422	
Interface to STG 4F	RS 422, 9-pole sub D socket	
Interface for 24 V DC	2-pole plug connector (included)	
Supply voltage ¹		
Nominal value	5/24 V DC	
Permissible range		
Internal (at 5 V)	4.75 to 5.25 V DC	
External (at 24 V)	Not required	
Current consumption (max.)		
Internal (at 5 V)	1 channel	370 mA
	2 channels	490 mA
	3 channels	610 mA
	4 channels	730 mA
Ambient temperature		
During operation	0° to +55° C	
During transportation and storage	-20° to +70° C	
Rel. humidity at 25° C	< 95%	
Space requirements	1 SEP (1 SEP = 15.24 mm)	
Weight (approx.)		
ASM 400	0.44 kg	
CM 422	0.1 kg	

1 With MOBY F, the voltage for the SLG cannot be connected via the ASM.

**Function block
FB 250**

Function block FB 250 controls data transmission between the STEP5 program and the ASM 400 interface module.

FB 250 can be used on the following “programmable controllers”.

- 115U/F - CPU 941/942/943/944/945
- 135U-R/S - CPU 928/928B
- 155U/H - CPU 948

FB 250 does not use system commands. All MDSs can be processed with FB 250.

Primary functions of FB 250

- Convert data from user parameterization structure to structure of an ASM
- All communication with the ASM via command data exchange
- Error handling: Command repetition; Preparation of errors for the user

Chaining of several partial commands into one complete command

- Reading and writing with a user command
- Any address areas of a mobile data memory can be processed with one command.
- Control of PLC cycle load via the user

Data transmission between FB and MDS can be subdivided into three phases.

- Supply interface with the appropriate command and the data or parameter
- Transmit the data between ASM 400 and MDS
- Supply S5 with appropriate parameters or data from the interface

When the P address area is available, FB 252 also supports operation of the ASM 400 in the expanded Q address area.

6.2.2 Hardware Description

Plug connectors and their assignment

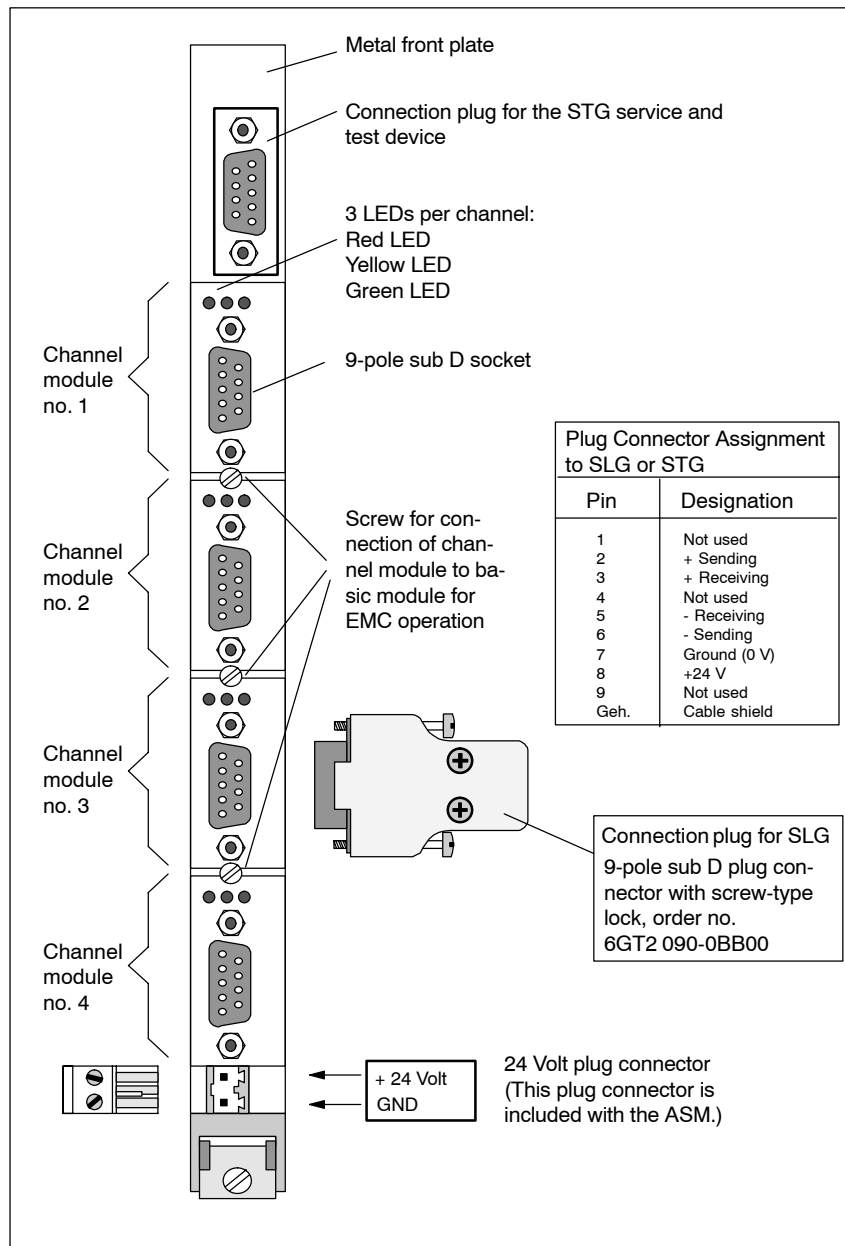

Figure 6-2 Plug connectors and their assignment for ASM 400

Note

With the MOBY F, the voltage supply for the SLG cannot be connected via the ASM.

Switches and plug-in jumpers

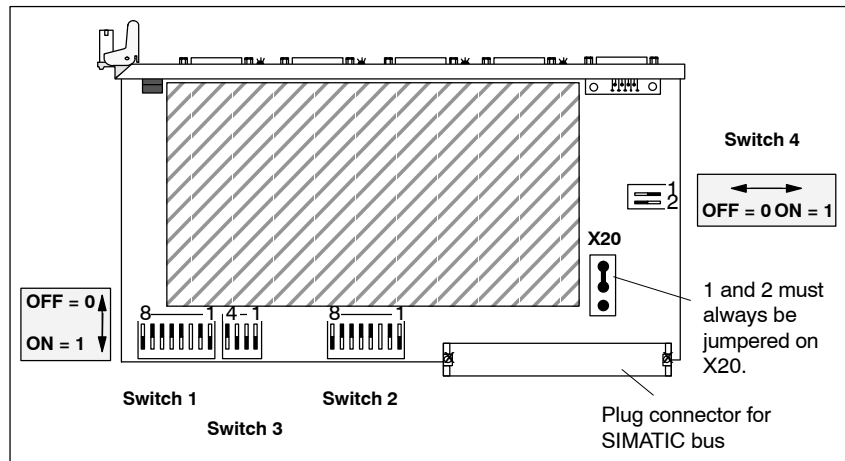

Figure 6-3 Switches and plug-in jumpers for ASM 400

Address settings

- S4 = Setting of the type of addressing
- S2 = Setting of the page frame number
- S3 = Setting of the module address (linear addressing with PESP)
- S1 = Address setting when PESP is not used

Table 6-4 Address settings for ASM 400 with FB 250/252

ASM 400 Switch Setting			FB 250 Parameterization		FB 252 Parameterization	
Start Address of ASM	Switch S3 4 3 2 1	Switch S4 2 1	ADR	KAN*	QADR	KAN
0	0 0 0 0	0 1	<div style="border: 1px solid black; padding: 5px; display: inline-block;">Not available</div>		0	1 - 4 (Corresponds to channel module 1 to 4)
16	0 0 0 1	(This setting of switch 4 must always be used when the module is operated in standard mode.)			16	
32	0 0 1 0				32	
48	0 0 1 1				48	
64	0 1 0 0				64	
80	0 1 0 1				80	
96	0 1 1 0				96	
112	0 1 1 1				112	
128	1 0 0 0			128	1 - 4	128
144	1 0 0 1		144	(Corresponds to channel module 1 to 4)	144	
160	1 0 1 0		160		160	
176	1 0 1 1		176		176	
192	1 1 0 0		192		192	
208	1 1 0 1		208		208	
224	1 1 1 0		224		224	
240	1 1 1 1		240	240	240	

Settings on the channel module

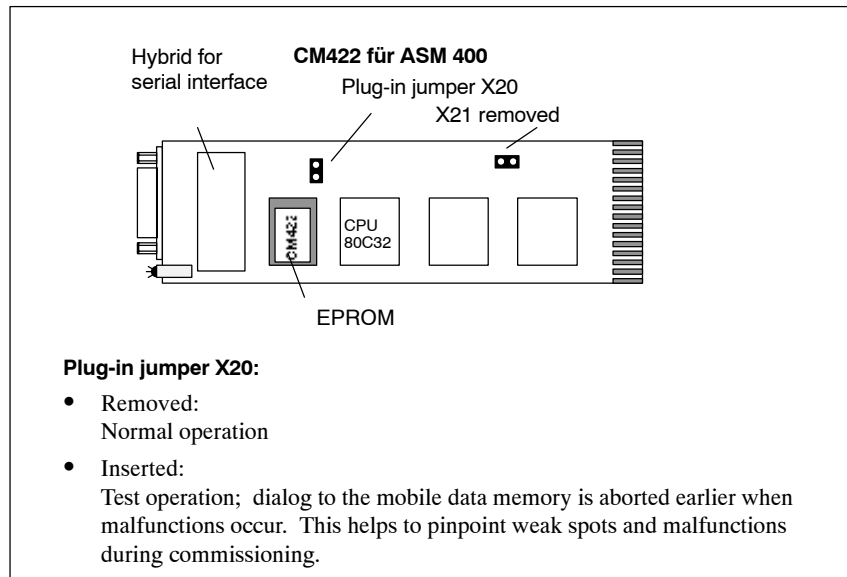

Figure 6-4 Settings on the channel module

6.2.3 SIMATIC S5 Configuration

**Module rack
CR 700-0LA
(S5-115U)**

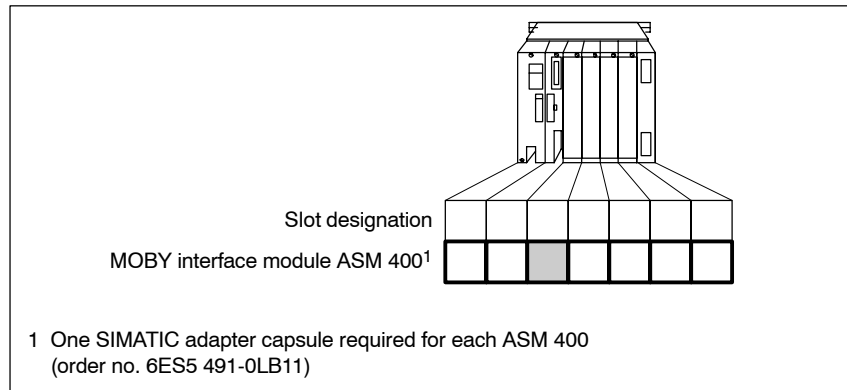

Figure 6-5 CR 700-0LA module rack (S5-115U)

**Module rack
CR 700-0LB
(S5-115U)**

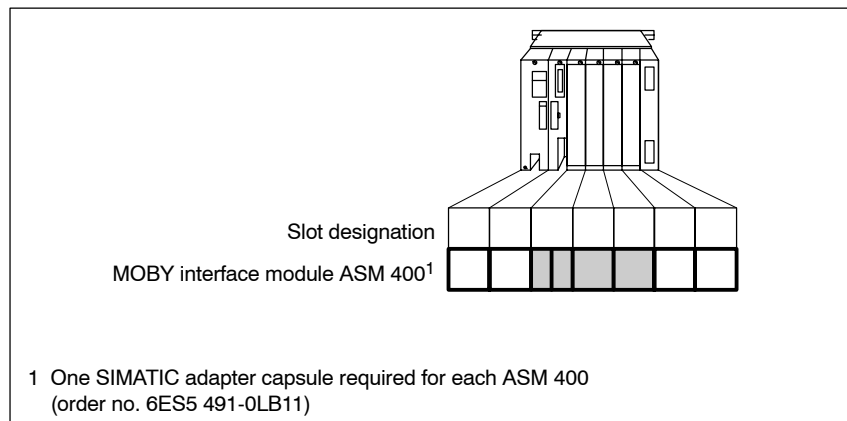

Figure 6-6 CR 700-0LB module rack (S5-115U)

**Module rack
CR 700-1 (S5-115U)**

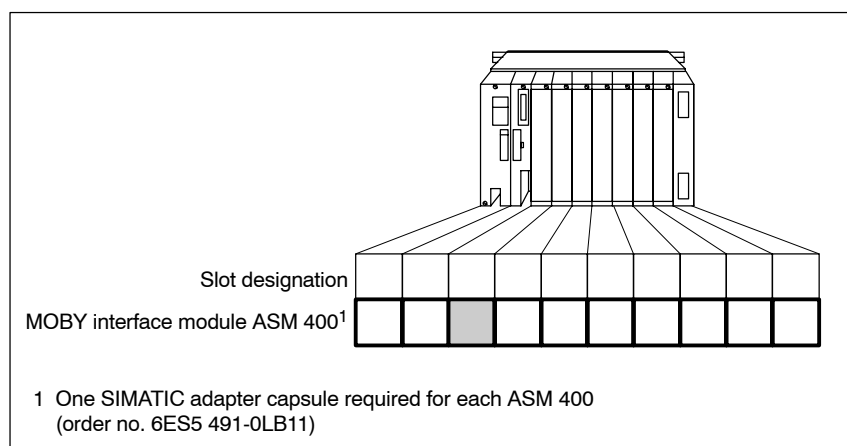

Figure 6-7 CR 700-1 module rack (S5-115U)

**Module rack
CR 700-2 (S5-115U)**

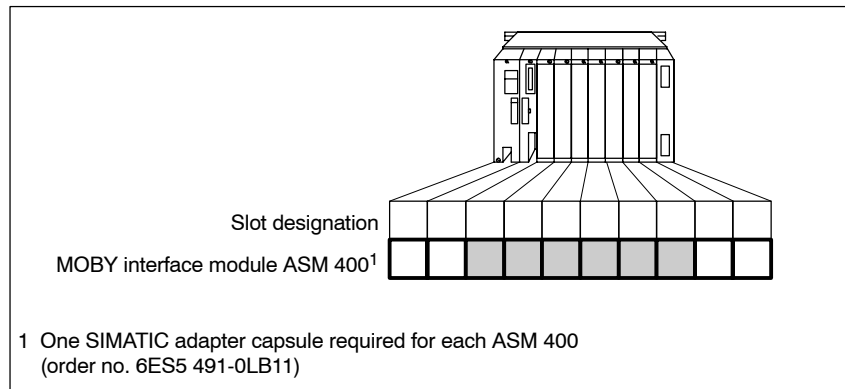

Figure 6-8 CR 700-2 module rack (S5-115U)

**Module rack
CR 700-3 (S5-115U)**

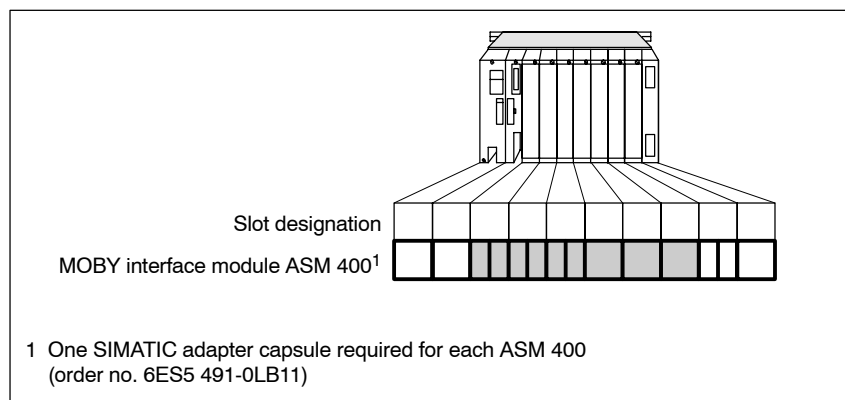

Figure 6-9 CR 700-3 module rack (S5-115U)

**Module rack
ER 700-0,
ER 701-1 and
ER 701-2**

ASM 400 MOBY interface modules cannot be used.

**Module rack
ER 701-3**

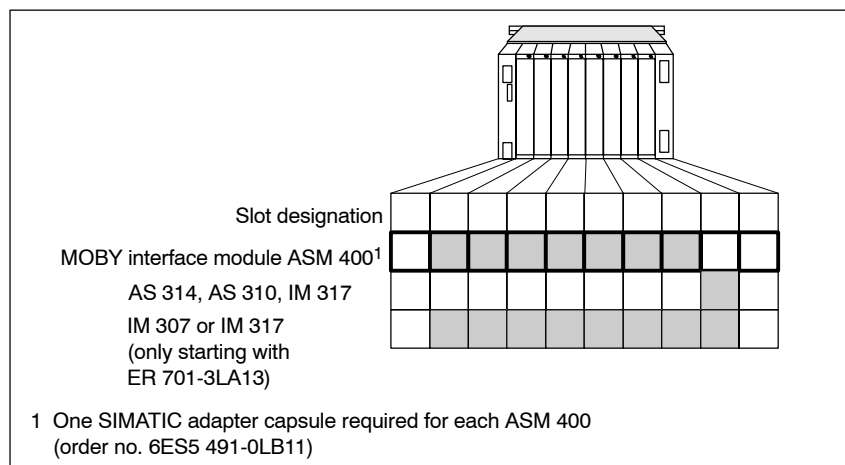

Figure 6-10 ER 701-3 module rack (S5-115U)

**Central controller
S5-135U/ -155U**

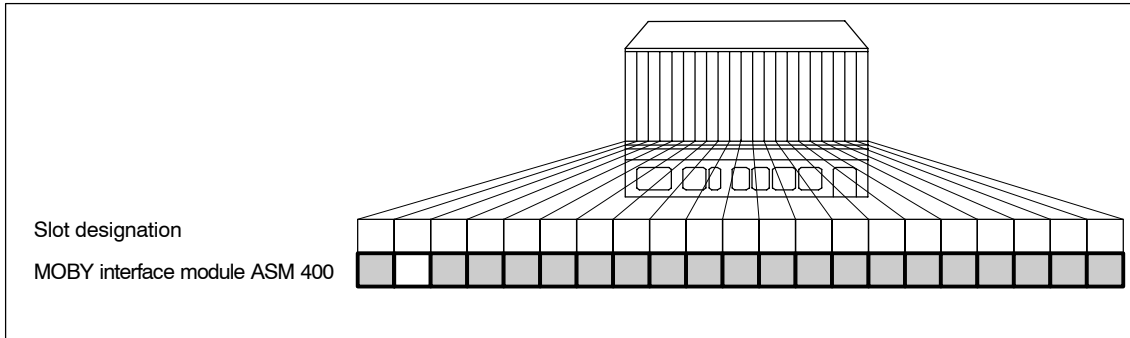

Figure 6-11 S5-135U/-155U central controller

**Central controller
S5-155U/155H**

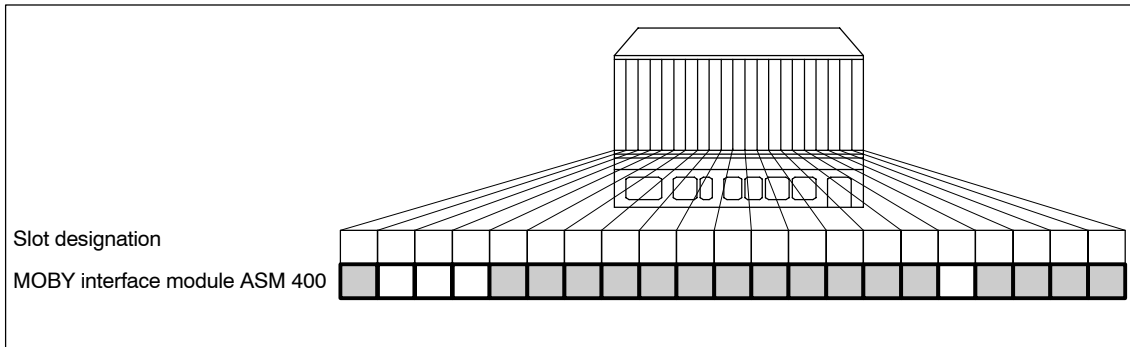

Figure 6-12 S5-155U/-155H central controller

**Expansion device
EG S5-183U**

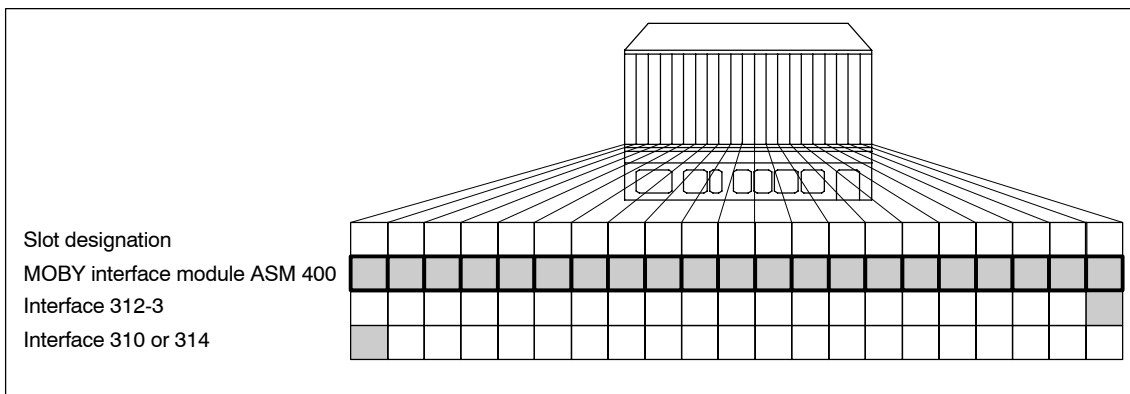

Figure 6-13 EG S5-183U expansion device for S5-135U/-155U

**Expansion device
EG S5-184U**

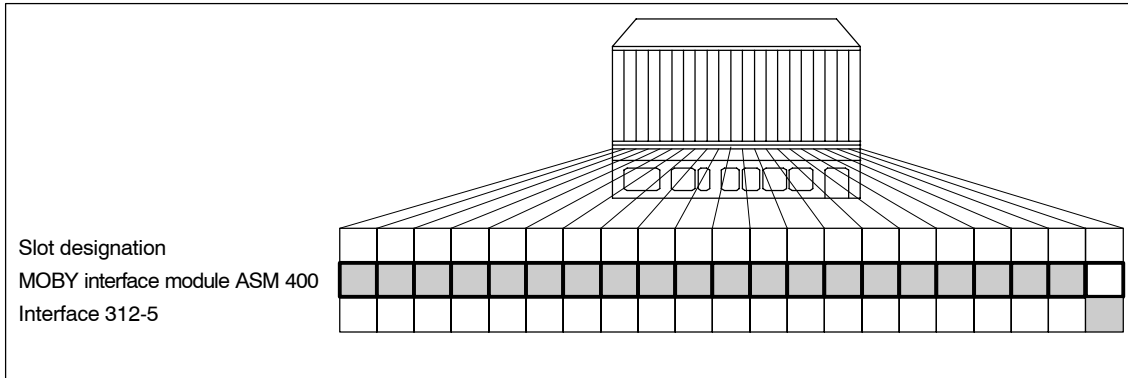

Figure 6-14 EG S5-184U expansion device for S5-135U/155U

**Expansion device
EG S5-185U**

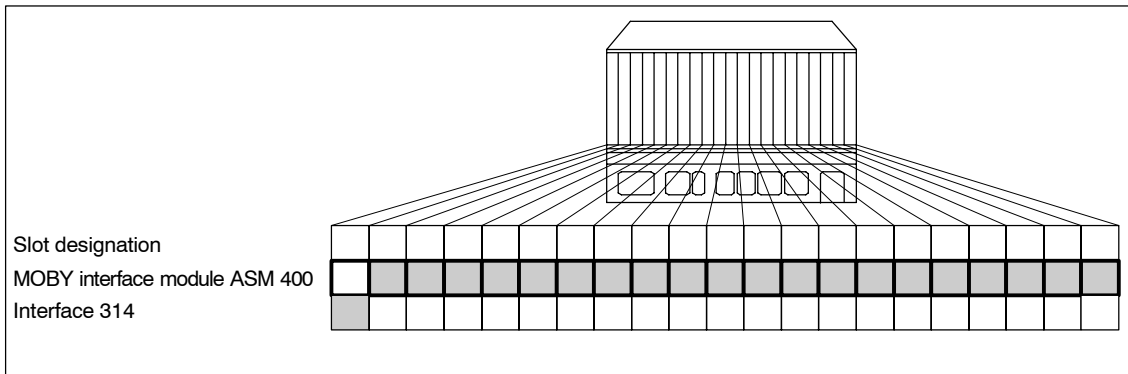

Figure 6-15 EG S5-185U expansion device for S5-135U/155U/155H

**Expansion device
EG S5-187U**

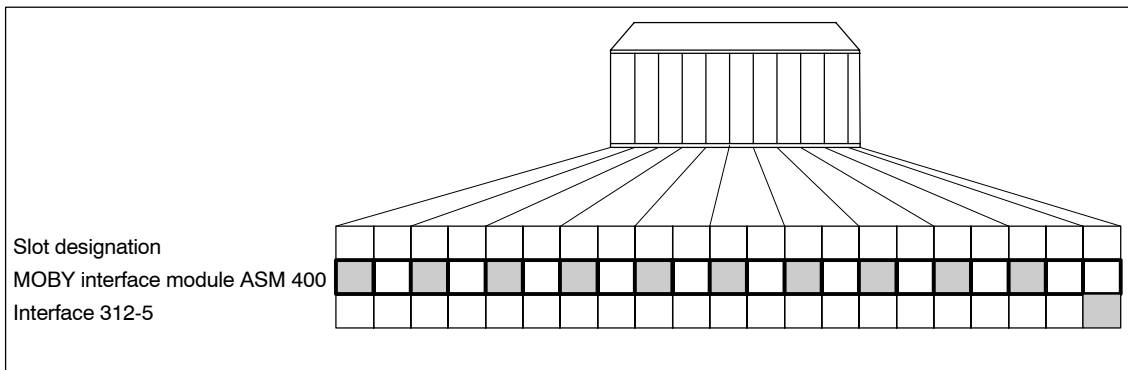

Figure 6-16 EG S5-187U expansion device for S5-135U/155U

6.3 ASM 410

Application area

Interface ASM 410 can be used in the SIMATICs listed below.

- S5-90U (max. of 2)
- S5-95U (max. of 4)
- S5-100U (max. of 8)
- ET 100U (max. of 2)
- ET 200U (max. of 4)

Since this ASM can be used with all mobile data memories, read/write devices and the STG service test device, compatibility with all MOBY components is ensured.

Layout and function

LEDs for status and error indications are located on the front. Interference-immune design is provided by the galvanic isolation of the MOBY interface to the SIMATIC S5 bus. The MOBY commands are started and data are fetched by setting and scanning a few control bits in the process image (PIO/PII), and eight input/output bytes are assigned. In time-multiplex operation, one or two SLGs can be used. The MDS data are accessed via their absolute addresses.

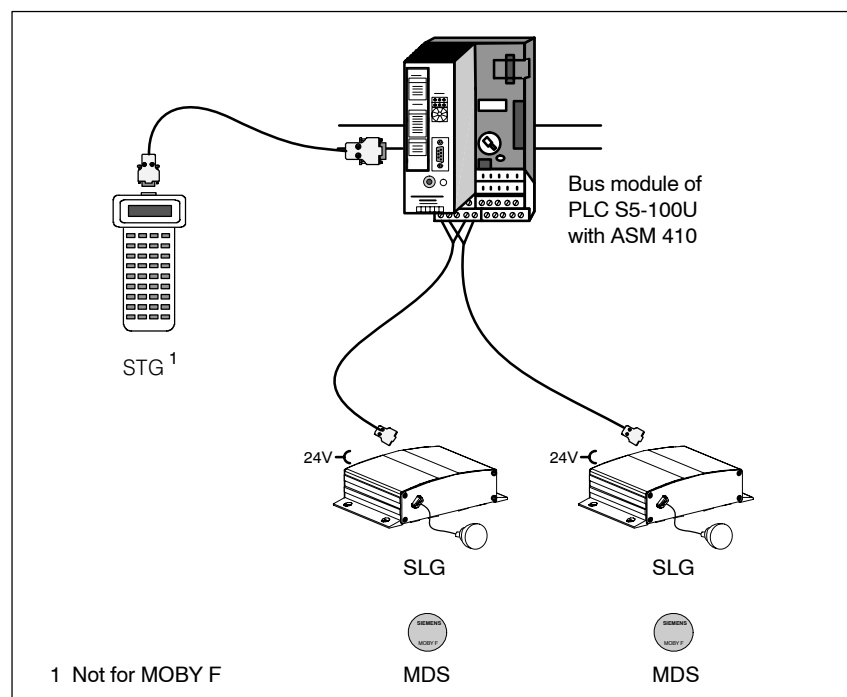

Figure 6-17 Configurator for ASM 410 in SIMATIC S5

Ordering data

Table 6-5 Ordering data of ASM 410

	Order No.
ASM 410 interface for connection of up to 2 SLGs (without bus module)	6GT2 002-0BA00
SIMATIC S5, bus module with terminal block for screw-type connection	6ES5 700-8MA11
Crimp connection, with crimp contacts, increased EMC resistance	6ES5 700-8MA22
Stub lines and accessories	See chapter 3.7.
Description of ASM 410 German English	Electronically available on "Software MOBY" CD

Technical data

Table 6-6 Technical data of ASM 410

Serial interface to SLG	RS 422
Connection (max.)	2 SLGs can be connected via a separate bus module
Line length (typ. max.)	1000 m/RS 422, depending on SLG and type of cable
Number of SLGs	
• Static operation	2 SLGs (8x)
• Dynamic operation	1 SLG (8x)
Interface to STG	RS 422, 9-pole sub D plug connection
Interface for 24 V DC	Via a separate bus module
Software functions	
Programming	With STEP5 directly via process image (PIO/PII); no function block required; 5 bytes processed per command
Commands	Select channel 1 or 2, read MDS, write MDS, initialize MDS, etc.
Supply voltage ¹	
Nominal value	24 V DC (residual ripple, max. of 10%)
Permissible range	20 to 30 V DC
Current consumption	
Internal (at 5 V) Typical	20 to 60 mA (20 mA = long cycle time) (60 mA = short cycle time)
Max.	110 mA (PLC in STOP status)
External (at 24 V DC)	
All SLGs, SLG switched off	90 mA
Power consumption, typ. (without SLG)	2.5 W
Cooling	Convection cooling
Isolation group	C in acc. w. VDE 0110
Protection rating	IP20 in acc. w. IEC 529
Physical stress	IEC 68-2-27
Ambient temperature	
During operation	
• Horizontal SIMATIC layout	0° to +60° C
• Vertical SIMATIC layout	0° to +40° C
During transportation and storage	-25° to +70° C
Weight (approx.)	0.25 kg

1 With the MOBY F, the voltage supply of the SLG cannot be connected via the ASM.

Slots in PLC S5-90U

PLC S5-90U provides a maximum of four slots for additional modules. Up to two of these can be used by the ASM 410 module.

Slots in PLC S5-95U

ASM 410 can only be operated with PLC S5-95U in slots 0 to 7. Up to four modules can be used on one PLC.

Starting with CPU release status -8MA-3, 8 modules can be used.

Slots in PLC S5-100U

ASM 410 can only be operated with PLC S5-100U in slots 0 to 7. Up to eight modules can be used on one PLC. See the following table for slot-oriented addressing.

	0	1	2	3	4	5	6	7	8
S5-100U	64 to 71	72 to 79	80 to 87	88 to 95	96 to 103	104 to 111	112 to 119	120 to 127	

Slot number

Address assignment

Free slots for additional digital modules

Configuration of ASM 410 in ET 100U

The ASM 410 must be operated as an analog module in the ET 100U. When parameterizing the module with the “COM ET 100U” software, the module must be specified with “4AX” in the appropriate slot. The ASM 410 occupies eight input bytes and eight output bytes (i.e., 16 bytes). Since a maximum of 32 bytes can be assigned per ET 100U in the address image of the main controller, a maximum of two modules per ET 100U are permitted. When other modules are used with an ET 100U in addition to the ASM 410, only one module can be connected.

On the ET 100U, the ASM 410 can be addressed via all address areas of the PLC (i.e., P, Q, IM3 and IM4).

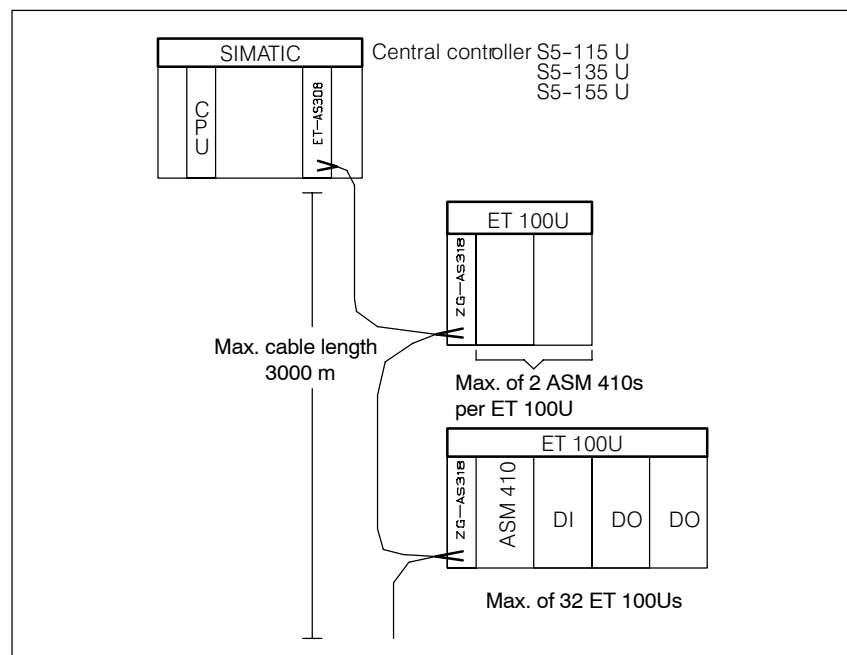

Figure 6-18 Configurator for ASM 410 in ET 100U

Configuration of ASM 410 in ET 200U

The ASM 410 can be used with the ET 200U under the following conditions.

- The ET 200U with an ASM 410 installed must be operated in slow mode. See ET 200U manual for how to set slow mode.
- The “COM ET 200U” software is used to parameterize the ASM 410. The ASM 410 module must be parameterized there with “095”.
- Up to four ASM 410s can be used with one ET 200U. When DI/DO or other periphery is used with the ET 200U, fewer ASM 410s can be used.

Otherwise the same conditions as for the ET 100U apply.

Table 6-7 Status and error LEDs of ASM 410

No.	Color	Meaning
A1	Red	Error: The last command was concluded with an error, or the hardware of the module is defective.
A2	Yellow	Rapid irregular flashing indicates running dialog with the SLG or mobile data memory (MDS). This LED is always on when the presence check is enabled.
A3	Green	Data memory is in the field of the SLG. The SLG which detected the MDS is indicated via LEDs B1-B2. LED is only active when presence check is being used.
B1	Green	B1 = 1st SLG is in operation. Remember: Only one of the LEDs (i.e., B1 and B2) may be on at a time. If both LEDs are on, check the wiring to the SLG.
B2	Green	B2 = 2nd SLG is in operation. Remember: Only one of the LEDs (i.e., B1 and B2) may be on at a time. If both LEDs are on, check the wiring to the SLG.
B3	Green	B3 = power on This LED is always on when 24 V is applied to the module. The interface module can be tested with the STG.

Setting the operating mode

The operating mode is set with the operating mode selection switch on the front of the ASM.

Positions 0 to 7

Setting of the operating mode:
ASM 410 uses the serial S5 bus. The STG interface is switched off.

Positions 8 to F

Test operation with the STG (not for MOBY F):
Telegrams from the S5 are no longer processed.

Note

The serial S5 bus functions are not affected by switching to test operation since this interface has its own microprocessor and is not dependent on MOBY activities.

Table 6-8 Operating modes for ASM 410

Switch Setting	Short Description on Label Insert	Meaning
0	Normal	Normal operating mode; read and write all MDS types; ECC driver is disabled.
1 ¹	ECC driver	Read and write all MDS types; ECC driver is enabled.
2	Test operation	All MDS types can be processed during test operation. The ASM 410 performs stricter error checks for communication with the MDS so that weak points and malfunctions can be detected during commissioning.
3 ¹	Test + ECC	The ECC driver is enabled. Otherwise same as switch setting 2.
4	INIT normal	Initializes the MDS. When a write command is started via the process image, an INIT command to the MDS is started. The contents of the MDS are deleted.
5 ¹	INIT ECC	Initializes the MDS with ECC driver. Otherwise same as switch setting 4.
6	Reserved	
7	Reserved	
8 ¹	Test 1st or 2nd SLG	An STG can be connected via the 9-pole sub D plug connector so that all MOBY E hardware can be tested.
9 to F	Reserved	

1 Switch settings 1, 3, 5 and 8 cannot be used with MOBY F.

Wiring of one or two SLGs

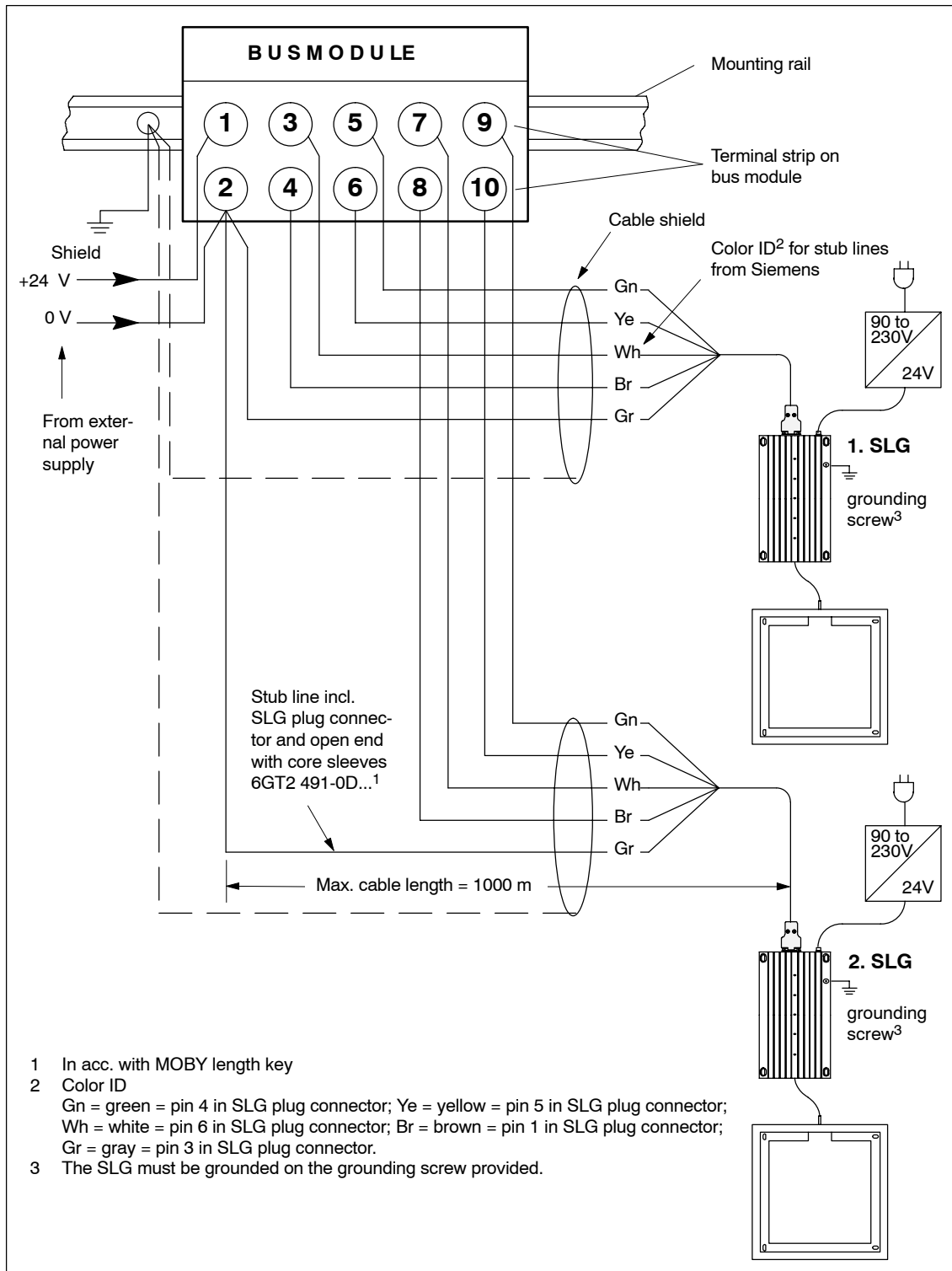

Figure 6-20 Wiring of one or two SLGs for ASM 410

6.4 ASM 450/452

Application area

The ASM 450/452 interfaces are modules for operation of MOBY devices via PROFIBUS DP / DPV1 on the following components.

- All computers and PCs
- All controllers

When the interfaces are used on a SIMATIC S7, function blocks are available to the user.



Figure 6-21 ASM 450/452 interface

ASM 450

The ASM 450 accesses data on the MDS directly with physical addresses. The ASM 450 uses cyclic operation with function block FB 240 (S5) or FC 44 (S7). Appendix B of the FC 44 description is available to the SIMATIC S5 user. All other users must use the description of the FC 44 function for the ASM 450.

Up to 2 SLGs can be connected to one ASM 450. Connection of two SLGs is only recommended when static operation is used. When MDSs are processed while passing by (i.e., dynamic operation), there is usually not enough time to switch over the second SLG.

ASM 452

The ASM 452 is the further development of the familiar ASM 450 interface. Use of non-cyclic data communication on PROFIBUS DPV1 ensures that optimum data throughput is achieved even with large PROFIBUS configurations. The minimum cyclic data load of the ASM 452 on PROFIBUS guarantees the user that other PROFIBUS stations (e.g., DI/DQ) can continue to work at very high speeds.

Up to 2 SLGs can be run on the ASM 452 in pseudo parallel mode. Pseudo parallel mode means that the user can start one command on 2 SLGs at the same time (via FC 45) although the ASM has only one serial channel. The ASM automatically handles the multiplexing between SLG 1 and SLG 2.

The SLG is processed on which an MDS happens to be. This delays the processing of the second MDS. For this reason, we recommend only processing the MDS statically when 2 SLGs are connected to the ASM. The MDS data are accessed via physical addressing of the MDS. The SIMATIC S7 offers FC 45 for this purpose. FC 45 gives the S7 user an easy-to-use interface with powerful commands (e.g., one command processes an entire MDS; command chaining; S7 data structures with UDTs). The ASM 452 can also be parameterized as a dialog station. Only 1 SLG can be operated on channel 1 in this mode. Available memory (VMDS) is then 1321 bytes.

Ordering data

Table 6-9 Ordering data for ASM 450/452

ASM 450 interface for PROFIBUS DP, max. of 2 SLGs connectable	6GT2 002-0EB00
ASM 452 interface for PROFIBUS DPV1, max. of 2 SLGs connectable	6GT2 002-0EB20
Accessories Plug connector for PROFIBUS DP connection and 24 V power supply	6ES7 194-1AA01-0XA0
Connection cable ASM 450/452 ↔ SLG Length: 2 m	6GT2 491-1CH20
5 m	6GT2 491-1CH50
20 m	6GT2 491-1CN20
For other lengths see chap. 3.7.4.	
Opt. connection plug, ASM 450/452 ↔ SLG	6GT2 090-0BC00
M12 covering caps for unused SLG connection (only ASM 450 and ASM 452) 1 package = 10 each	3RX9 802-0AA0
MOBY software ¹ with FB 246, FB 240, FC 44, FC 45 GSD file	6GT2 080-2AA10
Other accessories for ASM 450 (network components)	See SIMATIC catalog ST 70 and SIMATIC ET 200X manual.
Replacement part: Plug connector plate; T-functionality for PROFIBUS connection	6ES7 194-1FC00-0XA0
Description-ASM 450/FC 44 German	Electronically available on "Software MOBY" CD
English	
French	
Description-FC 45 (for ASM 452) German	Electronically available on "Software MOBY" CD
English	
French	

¹ See chapter 7.1.

Technical data

Table 6-10 Technical data of ASM 450/452

	ASM 450	ASM 452
Serial interface to the user	PROFIBUS DP	PROFIBUS DPV1
Procedure in acc. w.	EN 50170, vol. 2, PROFIBUS	
Connection	PG 11 screw connection PROFIBUS and supply voltage plug connectors are not included.	
Transmission speed	9600 baud to 12 Mbaud (automatic recognition)	
Max. block length	208 bytes	2 words cyclic/ 240 bytes acyclic
Serial interface to the SLG		
Plug connector	2 coupling plug connectors (M12)	
Line length (max.)	1000 m, depends on SLG (2 m = standard length, other cables: 5 m, 10 m, 20 m)	
SLGs which can be connected	2 SLG 8x (multiplex operation)	2 SLG 8x (pseudo parallel mode)
Software functions		
Programming	Depends on PROFIBUS DP master	
Function blocks		
SIMATIC S5	FB 240	–
SIMATIC S7	FC 44	FC 45
MDS addressing	Direct access via addresses	Direct access via addresses
Commands	Initialize MDS, read data from MDS, write data to MDS, and so on	Initialize MDS, read data from MDS, write data to MDS, and so on
Dialog: Normal station/VMDS	Yes/No	Yes/Yes (Only 1 SLG can be operated on channel 1 in VMDS mode.)
Supply voltage ¹		
Nominal value	24 V DC	
Permissible range	20 to 30 V DC	
Current consumption	180 mA max., 130 mA typ. (without SLG, DO not loaded)	

Table 6-10 Technical data of ASM 450/452

	ASM 450	ASM 452
Digital inputs		
Number	2	None
Galvanic isolation	Yes	
Input voltage		
For logical "0"	0 to 5 V DC	
For logical "1"	13 to 30 V DC	
Input current for signal "1"	7 mA (typ.)	
Delay time	< 10 msec	
Digital outputs		
Number	2	None
Galvanic isolation	Yes	
Max. permissible current	0.5 A	
Short-circuit protection	Yes (electronic)	
Line length (max.)	30 m	
Ambient temperature		
During operation	0° to +55° C	
During transportation and storage	-40° to +70° C	
Dimensions (WxHxD) in mm	134 x 110 x 55 (without bus plug)	
Mounting	4 M5 screws, mounting on any plate or wall	
Weight (approx.)	0.5 kg	
Protection rating	IP67	
MTBF (at 40 °C)	30 • 10 ⁴ hours = 34 years	

1 With the MOBY F, the SLG power supply cannot be obtained from the ASM.

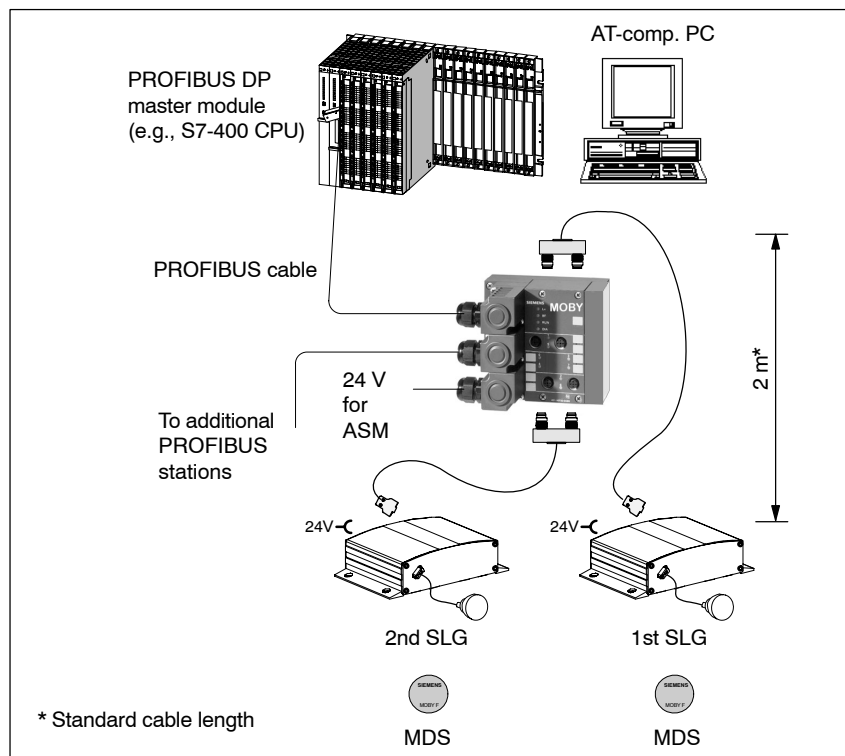

Figure 6-22 Configurator of ASM 450/452

Hardware description

The ASM 450/452 is equipped with the same housing as the ET 200X decentral I/O device. See ET 200X manual (order no. 6ES7 198-8FA00-8AA0) for general technical information on the ASM 450/452 (e.g., mounting, operation and wiring, and general technical specifications). Accessories and power supply components are also described in this manual.

PROFIBUS configuration

The ASM 450/452 is integrated in the hardware configuration with a GSD file. The ASM can then be configured via HWCONFIG of the SIMATIC Manager or another PROFIBUS tool. The “Software MOBY” CD contains a separate GSD file for each ASM model.

SLG connection technique

Since an SLG always occupies two M12 connection sockets on the ASM 450/451/452, a prefabricated cable (cf. figure 6-24 or chapter 3.7) makes it easy to connect the SLG. In its standard version, the connection cable has a length of 2 m. For other cable lengths, see chapter 3.7.4.

An SLG plug connector with screw-type terminals is available for users who want to make their own cable (see figure 6-23). Cable and SLG plug connector can be ordered from the MOBY catalog.

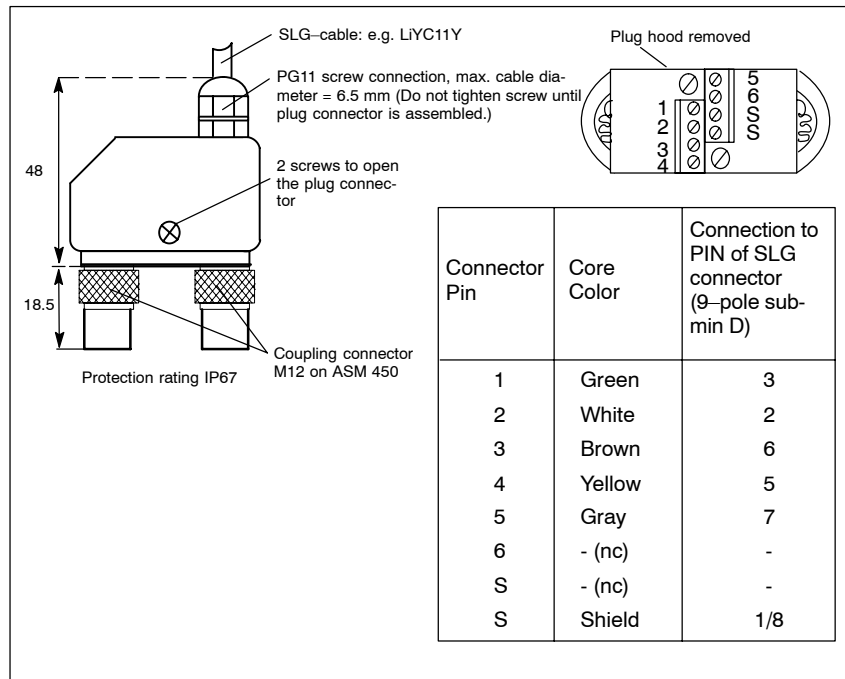

Figure 6-23 Connection plug, ASM 450/452 ↔ SLG (6GT2 090-0BC00)

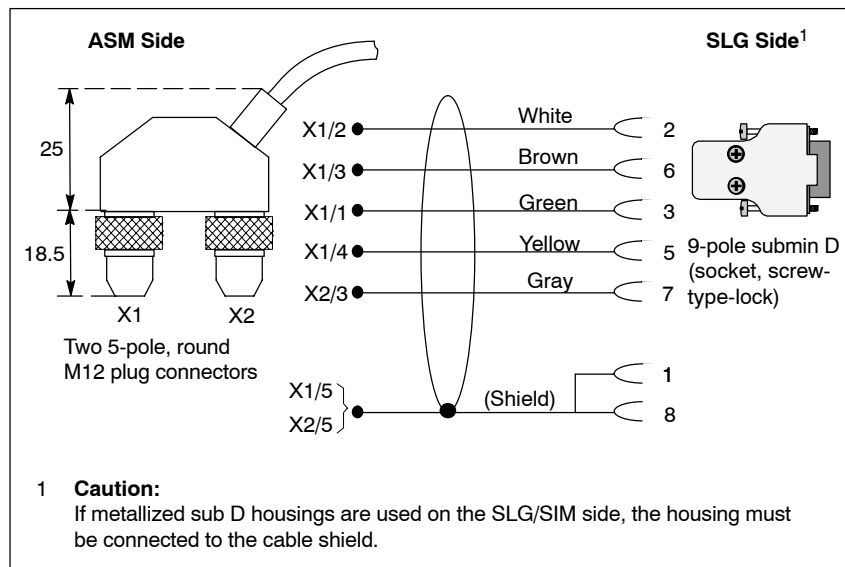

Figure 6-24 Connection cable, ASM 450/452 ↔ SLG (6GT2 491-1C...)

**PROFIBUS cable
with 24 V power**

The ASM 450/452 can also be used with the “green” PROFIBUS cable. Make sure that a 24 V cable is installed from X12 to X13. The 24 V line on plug X12 can be connected to pin 5, 6.

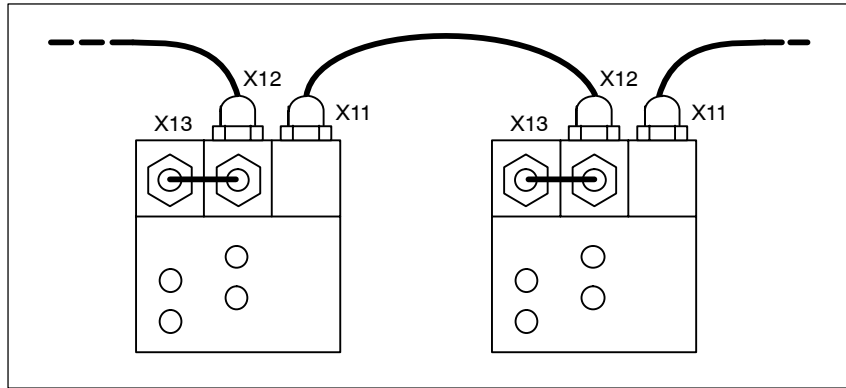

Figure 6-25 PROFIBUS cable with 24 V power

SLG and DI/DO configuration for ASM 450/452

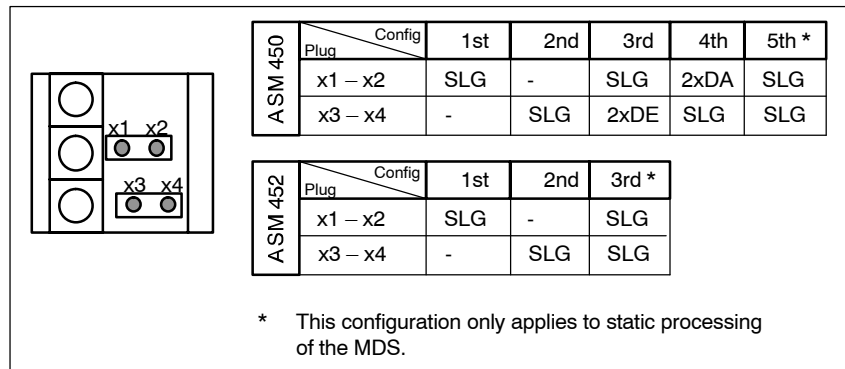

Figure 6-26 SLG and DI/DO configuration for ASM 450/452

The versions shown in figure 6-26 can be set up with the standard cables of MOBY or ET 200X.

Note

Although the configuration with 2 SLGs + DI + DO is also possible with the ASM 450, the components require special customer-related wiring.

Dimensional drawing of ASM 450/452 with mounting holes

The following figure shows a dimensional drawing of an ASM 450/452 with bus connection plugs. You must add the length of the PG screw connection and the radius of the cable used to the total width and depth specified.

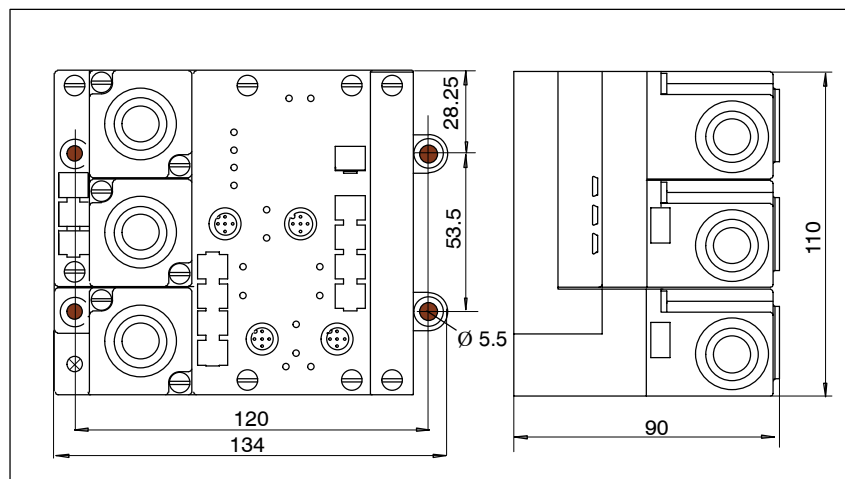

Figure 6-27 Dimensional drawing of the ASM 450/452

Pin allocation

The following figure shows the pin allocation of the ASM 450/452.

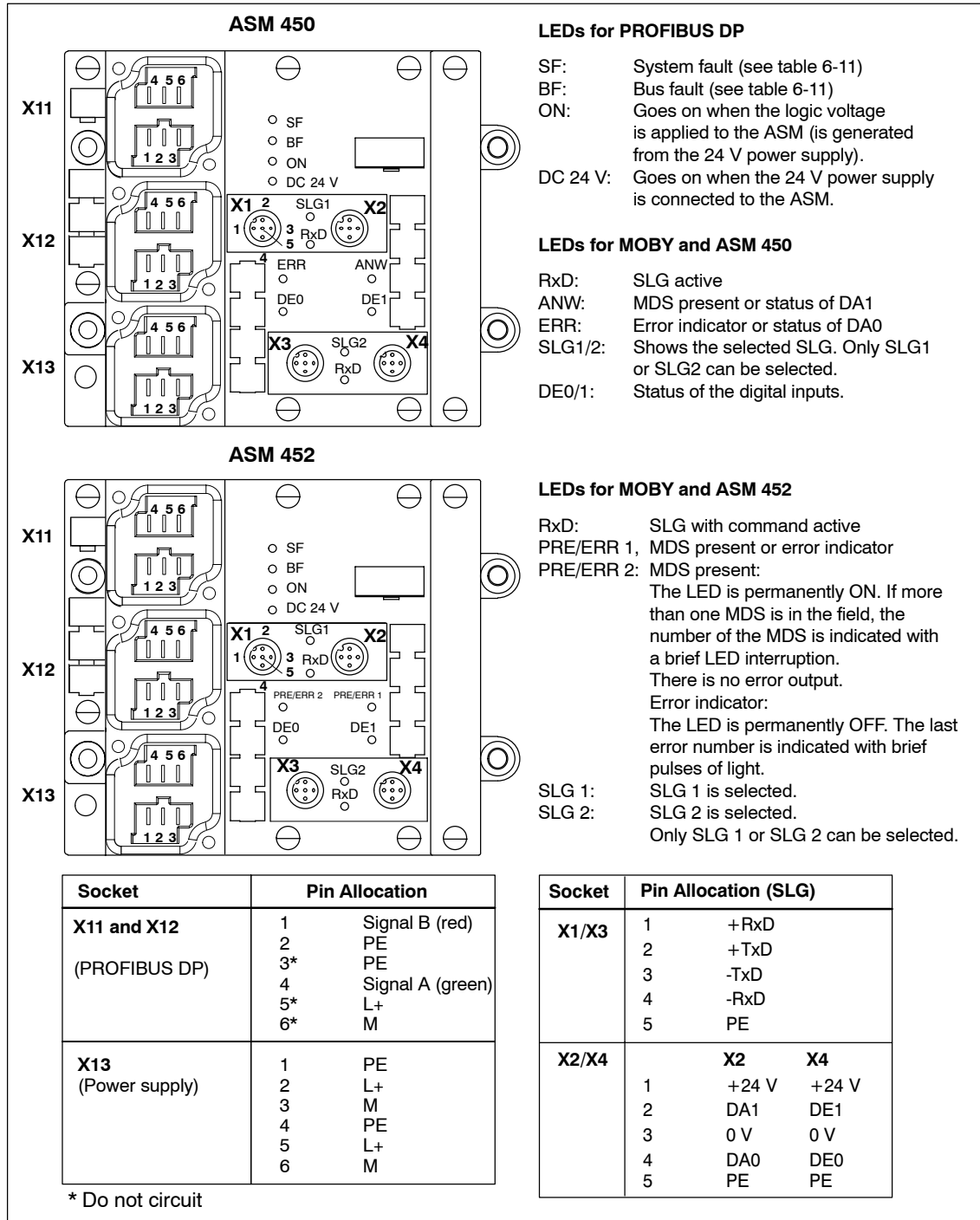

Figure 6-28 Pin allocation and LEDs of ASM 450/452

Note

With the MOBY F, the SLG power supply cannot be obtained from the ASM.

PROFIBUS diagnostics

The following table lists the possible error displays, what they mean and how to eliminate the cause of the fault.

Table 6-11 LEDs for PROFIBUS diagnostics

LED "BF"	LED "SF"	Cause	Error handling:
On	*	<ul style="list-style-type: none"> • ASM 450/452 is starting up. 	–
		<ul style="list-style-type: none"> • The connection to the DP-master has failed. • The ASM 450/452 cannot detect a transmission rate. 	<ul style="list-style-type: none"> • Check the PROFIBUS DP connection. • Check the DP-master.
		<ul style="list-style-type: none"> • Bus interruption • DP-master is out of operation 	<ul style="list-style-type: none"> • Check all the cables in your PROFIBUS DP network. • Check whether the PROFIBUS DP connector is plugged in correctly on the ASM 450/452.
Flashes	On	<ul style="list-style-type: none"> • The configuration data sent from the DP master to the ASM 450/452 do not correspond to the configuration of the ASM 450/452. 	<ul style="list-style-type: none"> • Check the configuration of the ASM 450/452 (input/output, PROFIBUS address). • Correct device master file used? <ul style="list-style-type: none"> – SIEM804C.GSD for ASM 450 – SIEM80B6.GSD for ASM 452
Flashes	Off	<ul style="list-style-type: none"> • The ASM 450/452 has detected the transmission rate but is not addressed by the DP master. • The ASM 450/452 was not configured. 	<ul style="list-style-type: none"> • Check the PROFIBUS address set on the ASM 450/452 or in the configuration software. • Check the configuration of the ASM 450/452 (station type).
On	Flashes	<ul style="list-style-type: none"> • There is a hardware defect on the ASM 450/452. 	<ul style="list-style-type: none"> • Replace the ASM 450/452.

* Status is not relevant

Example for bared lengths

The following figure shows an example of bared lengths. The lengths are valid for all cables which you can connect to the connection plug. Any shield braiding must be twisted, inserted in a core end sleeve, and the excess cut off.

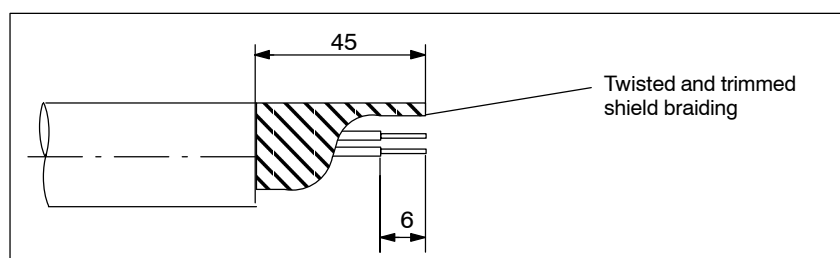

Figure 6-29 Length of baring for a PROFIBUS cable

PROFIBUS address and terminating resistance

The plug plate must be removed from the ASM before you can set the PROFIBUS address or circuit the terminating resistance. The plug plate covers the DIP switches. The following figure shows the location of the DIP switches on the ASM and a sample setting of each.

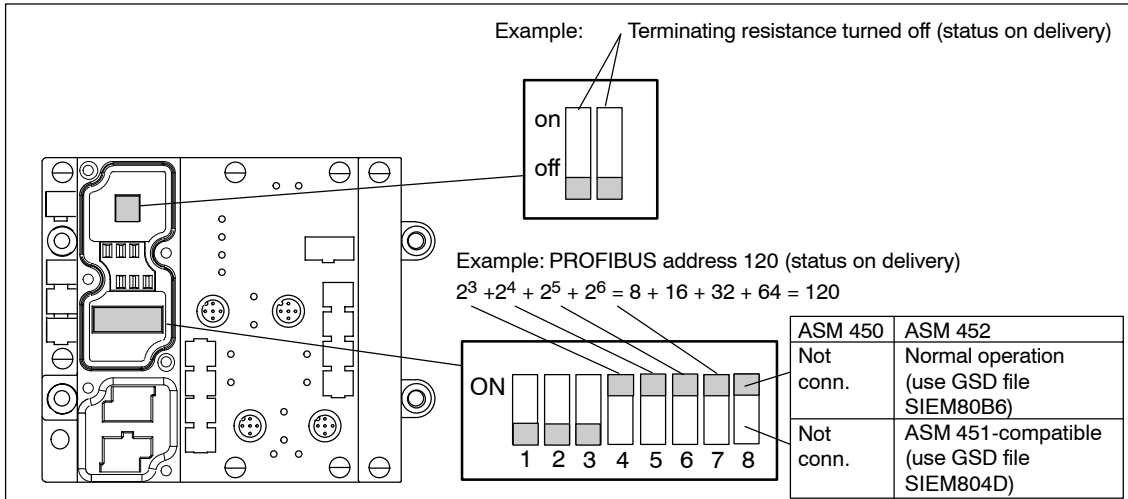

Figure 6-30 Setting the PROFIBUS address and circuiting the terminating resistance

Note

- The PROFIBUS address on the ASM 450/452 must always correspond to the PROFIBUS address specified for this ASM with the configuration software.
- For correct functioning of the terminating resistance, always switch both DIP switches of the terminating resistance to “On” or “Off”.

6.5 ASM 470/475

Application area

The ASM 470/475 interface can be installed in the SIMATIC S7-300 and ET 200M. It can be used for all MOBY systems.

Up to eight ASM 470/475 interfaces can be installed and operated in one module rack of the SIMATIC S7-300. When a layout with several module racks (maximum of four) is used, the ASM 470/475 can be installed and operated in each of these module racks. In a maximum SIMATIC S7-300 configuration, up to 32 ASM can be used centrally. The ASMs can also be used in the distributed I/O ET 200M on PROFIBUS. This makes use in an S7-400 environment possible. Up to 7 ASMs can be operated per ET 200M.

Error messages and operational states are indicated with LEDs. Galvanic isolation between SLG and the SIMATIC S7-300 bus ensure layouts which are not as susceptible to interference.



Figure 6-31 ASM 470/475 interface

ASM 470

In multiplex operation, up to two SLGs can be connected to the ASM 470. The FC 47 function block ensures simple programming via SIMATIC S7 tools. The FC 47 can be used with both the S7-300 and the S7-400. The ET 200M can also be used to operate the ASM 470 in a SIMATIC S5 environment. FB 47 is available for PLCs 115U to 155U.

On the hardware side, communication between ASM 470 and the S7-300 CPU is handled by a 16-byte address area so that up to 12 bytes of user data can be transferred with each read/write command.

ASM 475

The ASM 475 with the order number 6GT2 002-0GA10 is a parameterizable module. Basic functions of the module are already specified when the module is configured in HW-Config (e.g., normal addressing).

**ASM 475
(Normal
addressing)**

The ASM 475 accesses the data on the MDS directly with physical addresses. The FC 45 function controls use in a SIMATIC S7.

Together the ASM 475 and FC 45 form a unit which can be used to read the MDS data easily and at optimum speed. A 32-Kbyte MDS memory can be read in 24 seconds, almost without regard to the S7 cycle time.

**ASM 475
(Filehandler)**

The filehandler function is not offered by MOBY F.

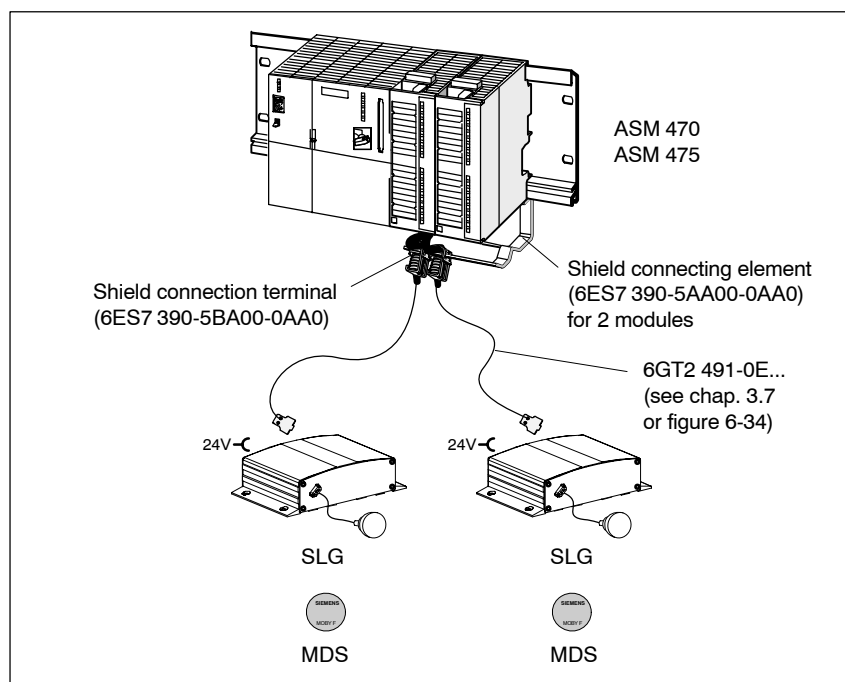

Figure 6-32 Configurator for ASM 470/475

Ordering data

Table 6-12 Ordering data for ASM 470/475

Interface ASM 470 for SIMATIC S7-300; 2 SLG multiplex; no front plug	6GT2 002-0FA10
Interface ASM 475 for SIMATIC S7-300; 2 SLG parallel; normal addressing; no front plug	6GT2 002-0GA10
Accessories Front connector (1 per ASM) Shield connection terminal (1 per SLG cable) Shield connecting element (1 per 2 ASMs) Connection cable, ASM ↔ SLG Length: 5 m 20 m 50 m MOBY software ¹ with FC 47, FB 47 for ASM 470, FC 45 for ASM 475	6ES7 392-1AJ00-0AA0 6ES7 390-5BA00-0AA0 6ES7 390-5AA00-0AA0 6GT2 491-0EH50 6GT2 491-0EN20 6GT2 491-0EN50 6GT2 080-2AA10
Description-ASM 470/FC 47 for S7 German English Description-ASM 470/FB 47 for S5 German Englisch Description-FC 45 (ASM 475) German Englisch French	Electronically available on “Software MOBY” CD Electronically available on “Software MOBY” CD Electronically available on “Software MOBY” CD

1 See chapter 7.1.

Technical data

Table 6-13 Technical data of ASM 470/475

ASM Type	ASM 470	ASM 475
Interface to S7-300 or ET 200M	P-bus; I/O input and I/O output	P-bus; cyclic and non-cyclic services
Communication	16 bytes I/O	2 words (cyclic); 238 bytes (non-cyclic)
Command buffer on ASM	1 x 12 bytes per ASM	70 x 238 bytes per SLG
Serial interface to the SLG		
Plug connector	Via screw terminals on front plug Front plug connector is not included.	
Line length, max.	Standard cable = 2 m, 5 m, 10 m, 20 m, 50 m (up to 1000 m on request)	
MOBY systems supported	I/E/F/V	I/E/F
Connectable SLGs	Multiplex 2 x SLG	Parallel 2 x SLG
Software functions		
Programming	SIMATIC user: With FC/FB Other users: Telegram description as per appendix of FC description	
Function block		
SIMATIC S7	FC 47	FC 45
SIMATIC S5	FB 47	—
MDS addressing	Direct access via addresses	
Commands	Initialize MDS, read data from MDS, write data to MDS	
Dialog MOBY I: Normal station/VMDS	Yes/Yes	Yes/No
PROFIBUS diagnosis	Yes. Can be parameterized via RESET.	
S7 diagnosis	No	Yes. Can be called via S7 OM.
Firmware reloadable	No	Yes. Via S7 OM.
Power supply¹		
Nominal value	24 V DC	
Permissible range	20 V to 30 V DC	20.4 V to 28.8 V DC
Current consumption		
<ul style="list-style-type: none"> Without SLG at U = 24 V DC, max. 	50 mA	350 mA
<ul style="list-style-type: none"> With SLG connected 	Max. of 600 mA with one SLG Max. of 300 mA per SLG when two SLGs are connected	Max. of 500 mA per connected SLG

Table 6-13 Technical data of ASM 470/475

ASM Type	ASM 470	ASM 475
Power loss of the module, typical	1 W	2 W
Current consumption from P-bus, max.	100 mA	80 mA
Galvanic isolation between S7-300 and MOBY	Depends (100 k Ω between S7-300 and 24 V DC)	Yes. Use for ungrounded operation of a separate power pack for the ASM.
Fuse, 24 V to SLG	Yes. Electronic.	Yes. Electronic.
Ambient temperature		
During operation		
• SIMATIC horizontal	0° C to +60° C	
• SIMATIC vertical	0° C to +40° C	
During transportation and storage	-40° C to +70° C	
Dimensions in mm (W x H x D)	40 x 125 x 120	
Weight, approx.	0.2 kg	

1 With MOBY F, the SLG voltage supply cannot be connected via the ASM.

Wiring

The ASM 470/475 is commissioned with the following steps.

- Mount module
 - Mount module on the S7-300 mounting rail. See S7-300 manual.
-

Note

The CPU of the S7-300 must be switched to STOP status before the module is mounted.



Warning

The S7-300 may only be wired when the voltage is off.

Note

To ensure interference-free operation of the ASM 475, make sure that ASM and SIMATIC CPU (or ASM and IM 153 with ET 200M) are run on the same voltage.

Non-adherence may cause possible error messages on the CPU not to be cleared when the ASM is turned on.

Front panel

The following figure shows the front plate of the ASM 470/475 and the inside of the front door with the related connection diagram. The SLGs must be connected to the ASM as shown in the connection diagram.

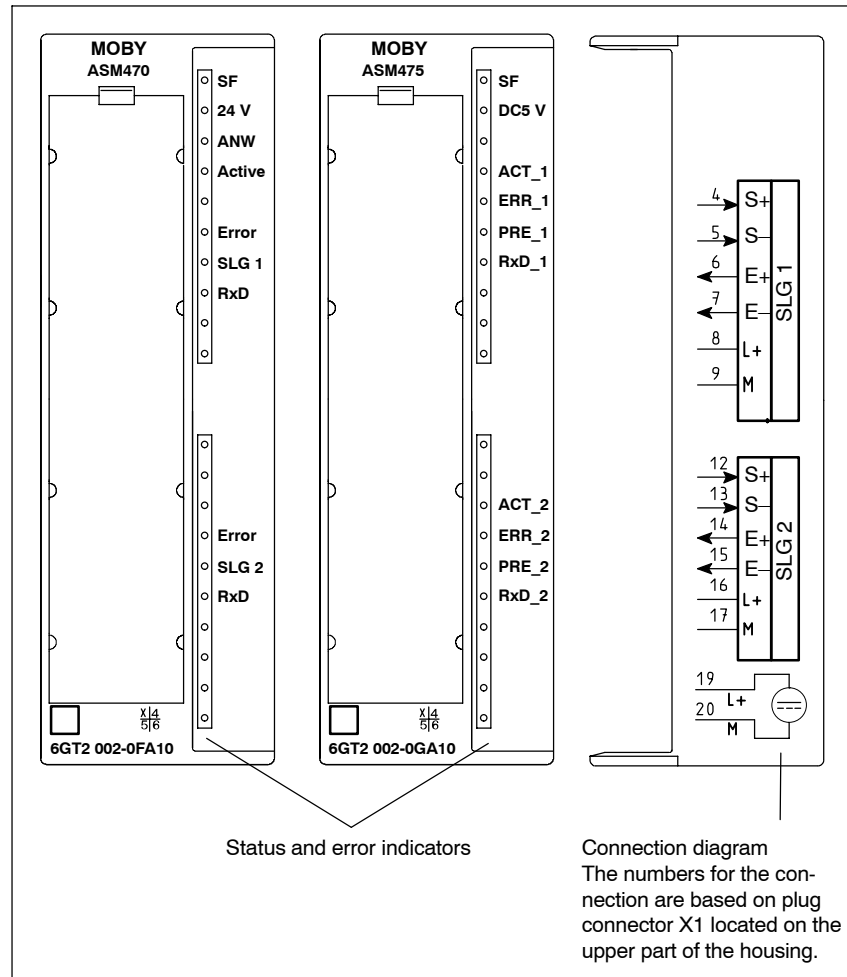

Figure 6-33 Front plate and inside of the front door of the ASM 470/475

Note

The power supply for MOBY F cannot be obtained from the ASM.

Indicator elements on ASM

Table 6-14 Function of the LEDs on ASM 470/475

ASM 470	ASM 475	Meaning
SF	SF	System fault (hardware error on ASM)
24 V	DC 5 V	24 V are connected to ASM. 5 V voltage on ASM is okay.
Active	ACT_1, ACT_2	The appropriate SLG is processing a user command.
Error	ERR_1, ERR_2	The flashing pattern shows the last error. This indicator can be reset with the option_1 parameter.
ANW	PRE_1, PRE_2	Indicates the presence of an MDS
RxD	RxD_1, RxD_2	Indicates communication to the SLG. Interference on SLG can also cause this LED to light up.
SLG 1, SLG 2	–	Indicates the SLG which was selected by the user command. Only one LED may light up at a time (multiplex operation).

Additional operational states are indicated on the ASM 475 on the LEDs PRE, ERR, and SF.

Table 6-15 Additional LEDs on the ASM 475

SF	PRE_1	ERR_1	PRE_2	ERR_2	Description, Causes, Remedy
ON	OFF/ON	ON (perm.)	OFF/ON	ON (perm.)	Hardware is defective (RAM, flash, ...)
ON	OFF	ON	OFF	OFF	Loader is defective (can only be fixed at the plant).
OFF	2 Hz	OFF	2 Hz	OFF	Firmware is being loaded or no firmware detected. → Load firmware. → Do not turn off ASM.
OFF	2 Hz	2 Hz	2 Hz	2 Hz	Firmware loading terminated with error → New start required. → Load firmware again. → Check update files.
Any	5 Hz	5 Hz	5 Hz	5 Hz	Operating system error → Turn ASM on/off.
OFF	OFF	1 x flash every 2 sec	OFF	1 x flash every 2 sec	ASM has booted and is waiting for a RESET (init_run) from the user.

Wiring to the SLG

The figure below shows a connection cable between ASM and SLG. The colors apply to the standard MOBY cable for the ASM 470. See chapter 3.7.3.

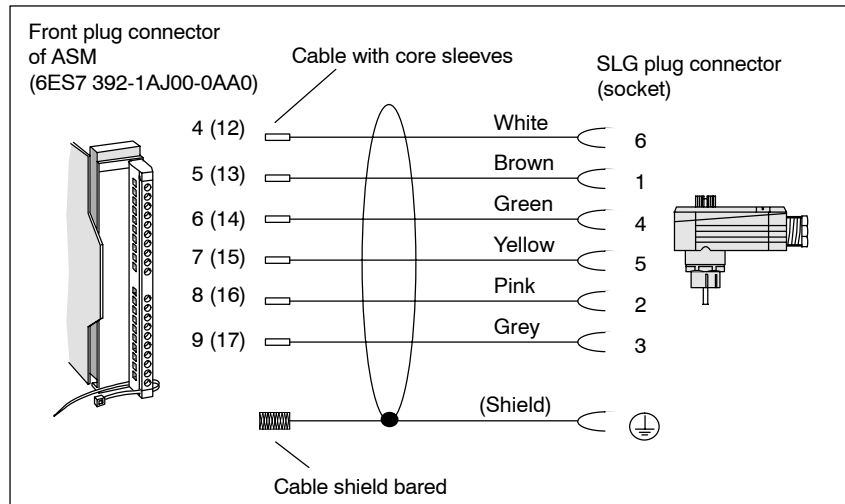

Figure 6-34 Wiring of ASM 470/475 to SLG (6GT2 091-0E...)

Shield connection

See chapter 3.6 or figure 6-32.

Lightning protection

Implement the lightning protection and grounding measures required for your application. Lightning protection measures always require individual consideration of the entire system.

Customer cable fabricating

To ensure EMC, the SLG cable must be led over an S7-300 shield connecting element (see figure 3-30). When customers make their own cables, the shield of the SLG cable must be bared as shown in figure 6-35.

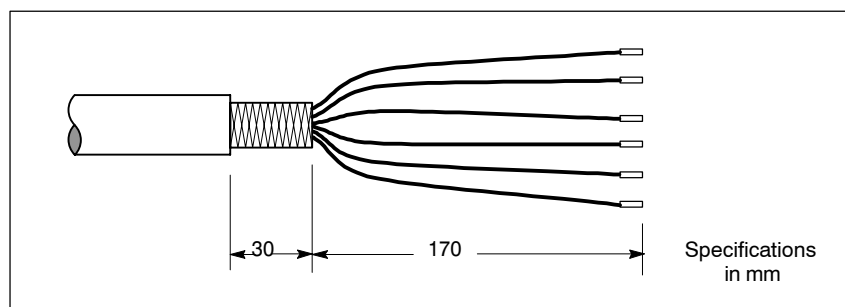

Figure 6-35 Baring of the cable shield when customer makes own cable

Configuration of ASM for SIMATIC S7 under STEP 7

Note

Installation of MOBY requires functional STEP 7 software on the PC/PG.

Installation and configuration of the ASM 470/475 in the SIMATIC is handled by an installation program. The installation program is included with the “MOBY software” product (6GT2 080-2AA10).

Installation

The “Software MOBY” CD contains the installation files in subdirectory S7_om. Installation is almost completely automatic when Setup.exe is called. The specified steps during SETUP must be responded to.

Note

Remember that you will have to execute a separate Setup for installation of ASM 470 and ASM 475.

The ASM 470/475 module is located in the hardware catalog of HWCONFIG under the following subdirectory for hardware configuration of the SIMATIC S7.

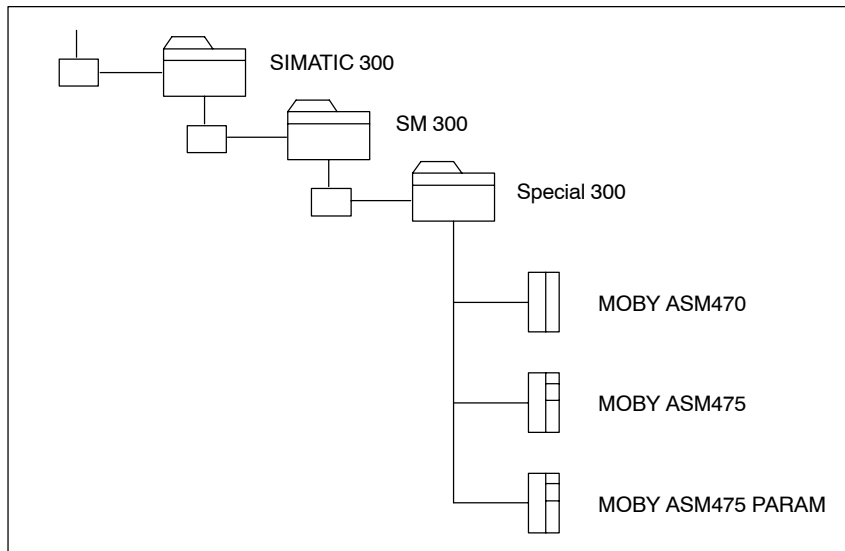

Figure 6-36 ASM 470/475 directory in the hardware catalog

**FC 45/47 with
sample project**

You can use the file-dearchivation function of the SIMATIC Manager to load the FC with a sample project from the applicable subdirectory of the “Software MOBY” CD. Afterwards, the sample project is located in the directory S7PROJ of the SIMATIC Manager.

ASM Type	Directory in “Software MOBY”	Project Name in SIMATIC Manager	Path Name in SIMATIC Manager
ASM 470	FC47	ASM470_CPU416	ASM470_C
ASM 475	FC45	MOBY FC45	Moby_f_1

6.6 ASM 473

Application area

The ASM 473 interface is a MOBY module for the SIMATIC S7. It can be installed in the ET 200X and DESINA distributed I/O device. The interface of the ET 200X to the user is PROFIBUS DPV1. An S7-300 or S7-400 with integrated PROFIBUS connection can be used as the controller.

The ASM 473 supplements the SIMATIC S7 MOBY interface modules ASM 470 and ASM 475. Its protection rating of IP 67 permits it to be set up and operated directly in the process without additional protection.

An ET 200X basic module (BM 141/142) with order number 6ES7 141-1BF11-0XB0 or 6ES7 142-1BD21-0XB0 is a prerequisite for use of the ASM 473.

Currently, the ASM 473 cannot be used with the preconditioning basic module BM 147/CPU.

The MDS data are accessed by physically addressing the MDS.

The FC 45 function is available for use in a SIMATIC S7. The hardware configuration of the ASM 473 is performed with an Object Manager which is integrated in the SIMATIC Manager.

Other features:

- Up to 7 ASM 473s can be operated in one ET 200X station.
- All I/O modules from the ET 200X family can be run parallel to the ASM 473.



Figure 6-37 ASM 473 interface

Ordering data

Table 6-16 Ordering data of ASM 473

ASM 473 interface module	6GT2 002-0HA00
Accessories: SLG cable (length 2 m = standard cable) Length: 5 m 20 m for other lengths, see chapter 3.7.4 Opt. ASM connection plug without SLG cable (for cable lengths > 20 m) Software MOBY ¹ with FC 45 incl. documentation	6GT2 491-1CH20 6GT2 491-1CH50 6GT2 491-1CN20 6GT2 090-0BC00 6GT2 080-2AA10
Description of FC 45 German English French	Electronically available on "Software MOBY" CD

1 See chapter 7.1.

Technical data

Table 6-17 Technical data of ASM 473

Interface to ET 200X Communication Command buffer in ASM	SIMATIC S7 P-bus Cyclic and non-cyclic services 2 words (cyclic)/ 238 bytes (non-cyclic) 142 x 238 bytes
Serial interface to SLG Plug connector Line length, max. Connectable SLGs	2 x coupling plug, M12 20 m 2 m = standard length Other fabricatable cables = 5 m, 20 m (up to 1000 m on request) 1 x SLG 8x
Software functions Programming SIMATIC S7 function block MDS addressing Commands PROFIBUS diagnosis S7 diagnosis Reloadable firmware	Depends on PROFIBUS DP ma- ster FC 45 Direct access via addresses Initialize MDS, read data from MDS, write data to MDS Yes; ET 200X basic station. Yes. Can be called via S7 OM. Yes. Via S7 OM.

Table 6-17 Technical data of ASM 473

Power supply ¹	
Nominal value	24 V DC
Permissible range	20.4 V to 28.8 V DC
Current consumption	
• From encoder voltage	75 mA, typical
Power loss of module	1.6 W, typical
Digital inputs	Via expansion modules from ET 200X family
Digital outputs	Via expansion modules from ET 200X family
Ambient temperature	
During operation	0° C to +55° C
During transportation and storage	-40° C to +70° C
Dimensions (W x H x D) in mm	
Dimensions of single devices	87 x 110 x 55
Dimensions of scale	60 x 110 x 55
Mounting	2 M5 screws (customer) 2 M3 screws (device)
Protection rating	IP67
Weight	0.275 kg

1 With MOBY F, the SLG power supply cannot be obtained from the ASM.

For setup guidelines and other general technical data, see the ET 200X manual (order no. 6ES7 198-8FA01-8AA0).

Configuration

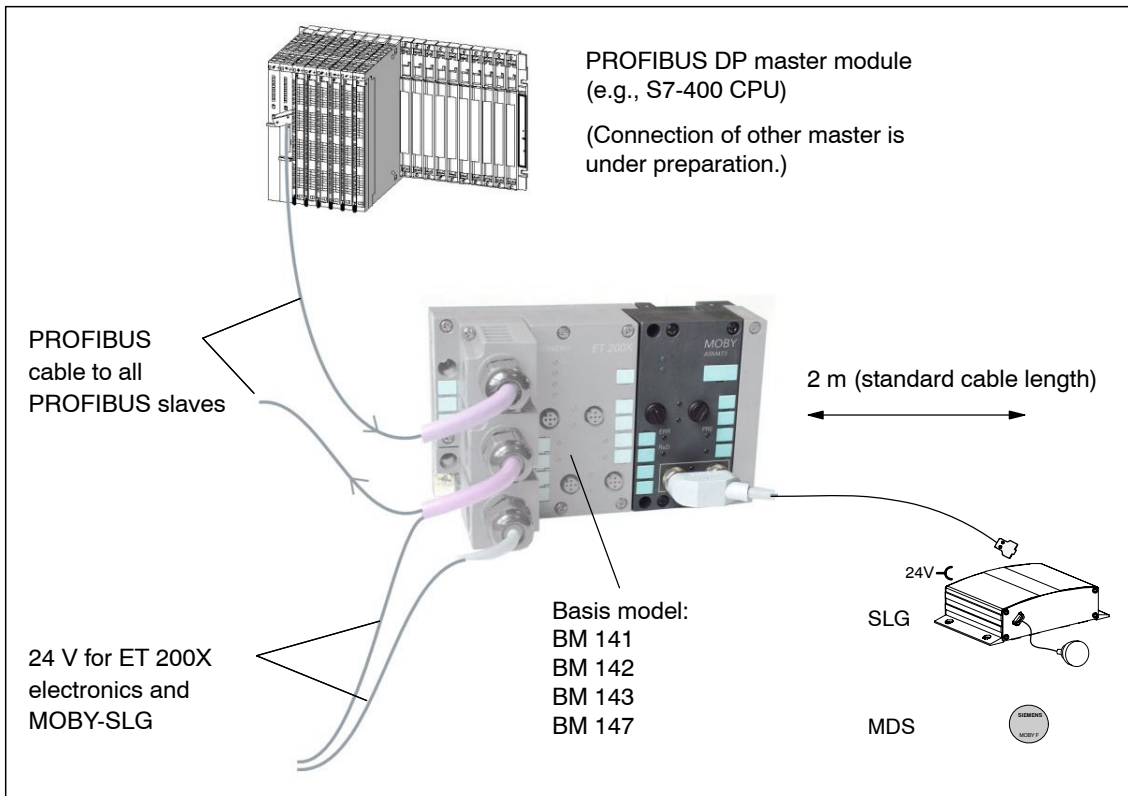

Figure 6-38 Configurator for an ASM 473

Note

In contrast to ASM 45x (see figure 6-22), the 24 V power must be provided on the PROFIBUS plug and the load voltage plug. For details, see ET 200X manual.

Basis module – prerequisites for operation of the ASM 473

The following table shows the status of the ET 200X modules as of 06/2002. The functionality of newer basis modules is stored in HW-Config of SIMATIC Manager.

Table 6-18 Prerequisites for operation of the ASM 473

Order Number of the ET 200X Basis Module	To Operate with ASM 473 (6GT2 002-0HA00)	To Operate with ASM 473 PARAM (6GT2 002-0HA10)
6ES7 141-1BF00-0XB0	No	No
6ES7 141-1BF00-0AB0	Yes	Yes
6ES7 141-1BF01-0XB0	No	No
6ES7 141-1BF10-0XB0	No	No
6ES7 141-1BF11-0XB0	Yes	Yes
6ES7 141-1BF40-0AB0	Yes	Yes
6ES7 142-1BD10-0XB0	No	No
6ES7 142-1BD11-0XB0	No	No
6ES7 142-1BD20-0XB0	No	No
6ES7 142-1BD21-0XB0	Yes	Yes
6ES7 143-1BF00-0AB0	Yes	Yes
6ES7 143-1BF00-0XB0	Yes	Yes
6ES7 147-1AA00-0XB0	No	No
6ES7 147-1AA01-0XB0	No	Yes

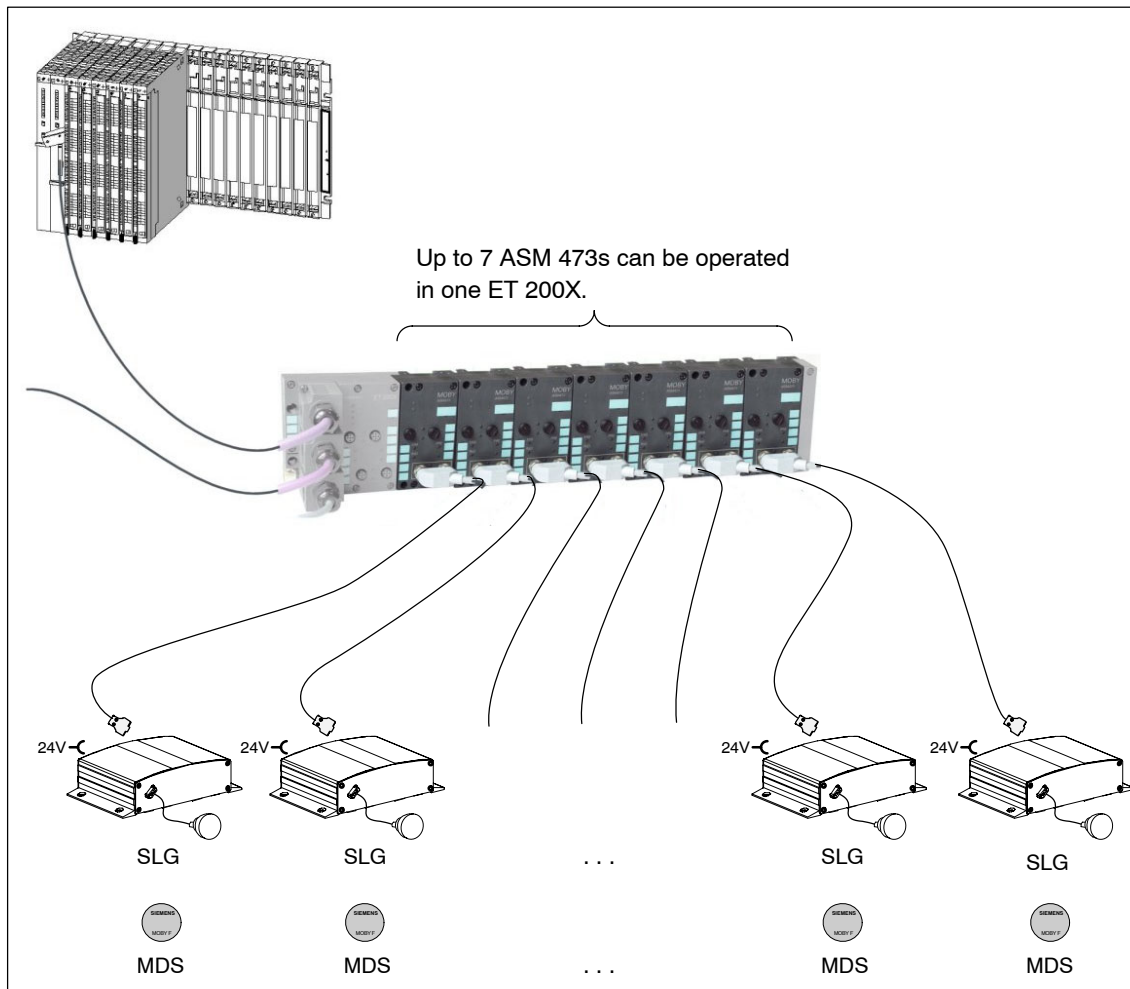

Figure 6-39 Maximum configuration of ASM 473 on an ET 200X

Depending on the PROFIBUS master, up to 123 ET 200X modules can be run on one PROFIBUS branch.

Hardware configuration

The ASM 473 is integrated in the hardware configuration of SIMATIC Manager by calling Setup.exe in the directory daten/S7_OM on the "Software MOBY" CD. Currently, the ASM 473 cannot be integrated in other masters.

SLG connection

An SLG always occupies the two M12 connection sockets (X3 and X 4) on the ASM 473. A prefabricated cable (cf. figure 6-24 or chapter 3.7) ensures easy connection of the SLG. The standard version of this cable is 2 m in length. Other lengths are available on request.

An SLG connection plug with screw terminals (see figure 6-23) is available for users who want to make their own cable. Cable and SLG connection plug can be ordered from the MOBY catalog.

Pin assignment

The following figure shows the pin assignment to the SLG and the indicator elements.

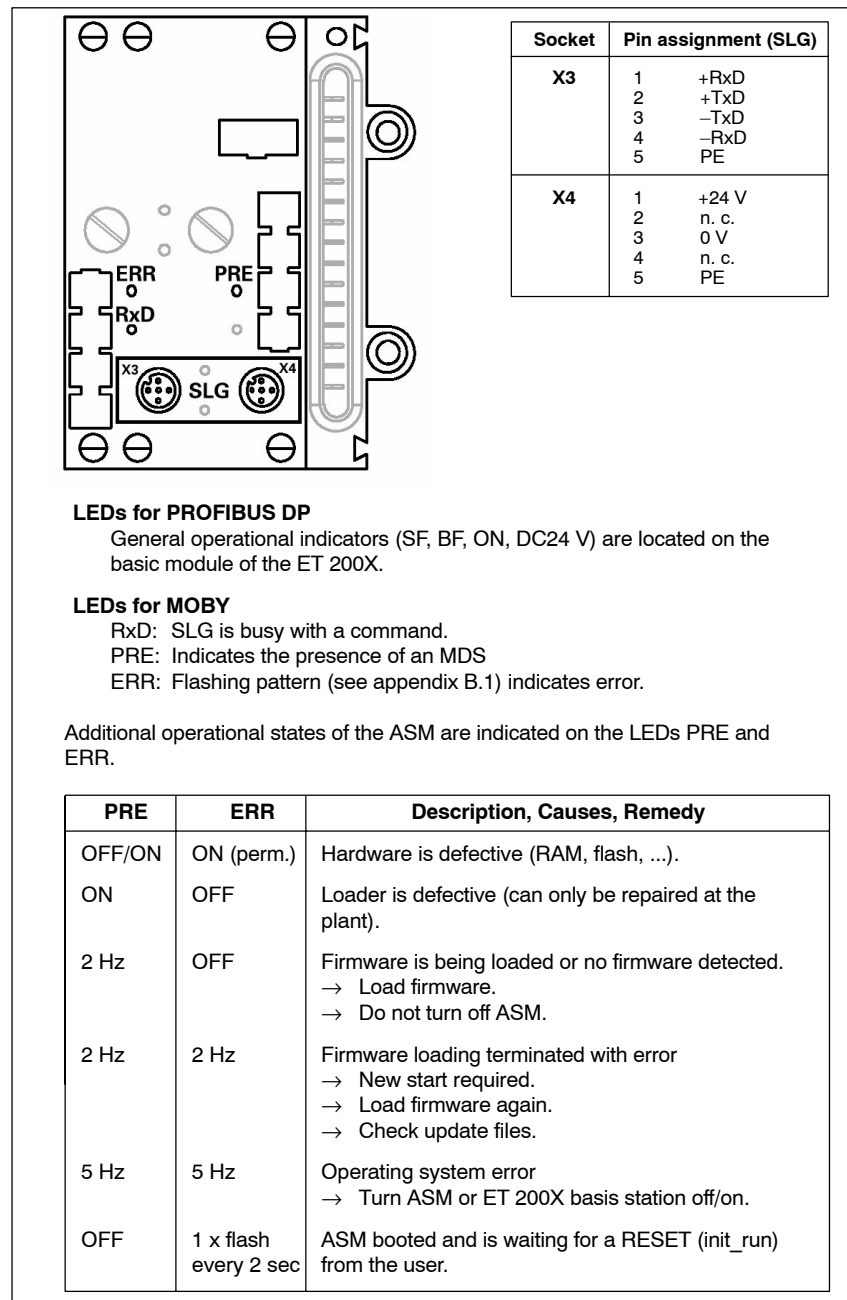

Figure 6-40 Pin assignment and LEDs of ASM 473

Note

With the MOBY F, the SLG power cannot be connected via the ASM.

Dimensions for the mounting holes

The figure below shows the dimensions for the positions of the holes for the screws. This information applies to a basic module and an expansion module (ASM 473).

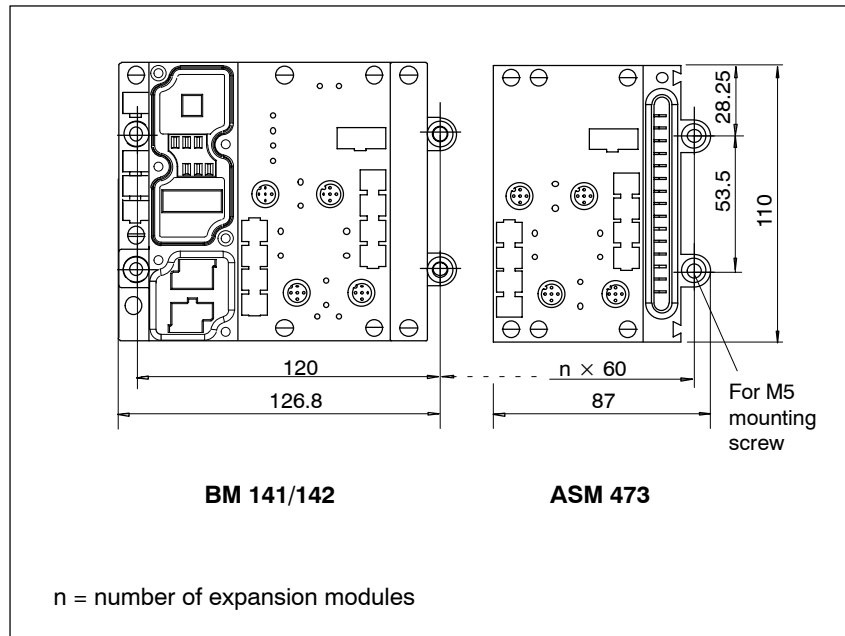

Figure 6-41 Dimensions for mounting holes for basic and expansion modules.

6.7 ASM 824/850/854

Application area

The ASM 824/850/854 interfaces are designed for distributed installation in warehousing, logistical and distribution applications. The functional, robust housing fits anywhere. Up to four read/write antennas can be connected and run parallel to each other. This ensures dynamic operation of MDS and SLA. The read/write antennas (SLA 81) and stub lines must be ordered separately. The MOBY wide-range power pack (6GT2 494-0AA00) can be used. The user has a choice of two interfaces.

- PROFIBUS DPV1 (ASM 850, ASM 854)
- RS 232: serial interface to PC and PC-compatible controllers (e.g., SICOMP, ASM 824)



Figure 6-42 ASM 824/850/854 interface module

ASM 824

Data on the MDS are accessed with the ASM 824 directly with physical addresses. The ASM 824 can be operated in parallel with up to four SLA 81s. Communication to the user is handled by a serial RS 232/422 interface with the 3964R protocol. This provides an easy way to connect PCs and other controllers to the MOBY F identification system. A C library (MOBY API) is available to users for their application.

ASM 850

The ASM 850 accesses the data on the MDS directly via physical addresses. The ASM 850 is a low-cost solution for the connection of **one** SLA 81. Communication to the user is handled by the non-cyclic protocol service of PROFIBUS DPV1. Function FC 45 is available to SIMATIC S7-300/400 users for simple integration.

ASM 854

The ASM 854 accesses the data on the MDS directly with physical addresses. Communication to the user is handled by the non-cyclic protocol service of PROFIBUS DPV1. Function FC 45 is available to SIMATIC S7-300/400 users for simple integration. The ASM 854 can be operated in parallel with up to four SLA 81s.

The description of the PROFIBUS DPV1 implementation is available to programmers of other controllers (see appendix of FC 45 description).

Ordering data

Table 6-19 Ordering data of the ASM 824/850/854

ASM 824 interfaces with RS 232/RS 422 serial interface. 3964R procedure for PC, SICOMP and other controllers. For four SLA 81s.	6GT2 402-2CE00
ASM 850 interfaces for operation of MOBY F components via PROFIBUS DPV1, without filehandler. For one SLA 81.	6GT2 402-2EA00
ASM 854 interfaces for operation of MOBY F components via PROFIBUS DP and DPV1 (PROFIBUS DP only for MDS 1xx (r/o)). Without filehandler. For four SLA 81s.	6GT2 402-2BB00
Accessories:	
Read/write antenna, SLA 81	6GT2 401-2BB00
Standard connection cable between SLA 81 ↔ ASM 824/850/854.	
Length: 5 m	6GT2 391-1AH50
Extension for antenna cable 6GT2 391-1AH50.	
Length: 10 m	6GT2 391-1BN10
25 m	6GT2 391-1BN25
Mounting clamp for SLA 81	3SX6 284
Wide-range power pack, 100 to 230 V AC/ 24 V DC. 2.2 A (without 24 V cable).	6GT2 494-0AA00
24 V DC stub line for wide-range power pack, 6GT2 494-0AA00.	
Length: 5 m	6GT2 491-1HH50
RS 232 stub line between PC and ASM 824. Can be fabricated up to 32 m. For lengths see chapter 3.7.4.	6GT2 391-0B...
Plug connector for voltage supply (socket) for ASM 824/850/854	6GT2 390-1AB00
PROFIBUS plug connector 9-pole, submin. D plug connector for 2 stub lines	6ES7 972-0BA11-0XA0 (For other plug connectors, see catalog ST 70 or IK PI.)

Table 6-19 Ordering data of the ASM 824/850/854

Adapter floor plate for top hat rail mounting for ASM 824/850/854	6GT2 390-0BA00
C library for ASM 824 (MOBY API)	Included on "Software MOBY" CD (see chap. 7.1)
FC 45 for ASM 850 and ASM 854	Included on "Software MOBY" CD (see chap. 7.1)
Description of FC 45 For programming ASM 850/854 German English French	Electronically available on "Software MOBY" CD
Description MOBY API (C-Lib for ASM 850/854) German English	Electronically available on "Software MOBY" CD

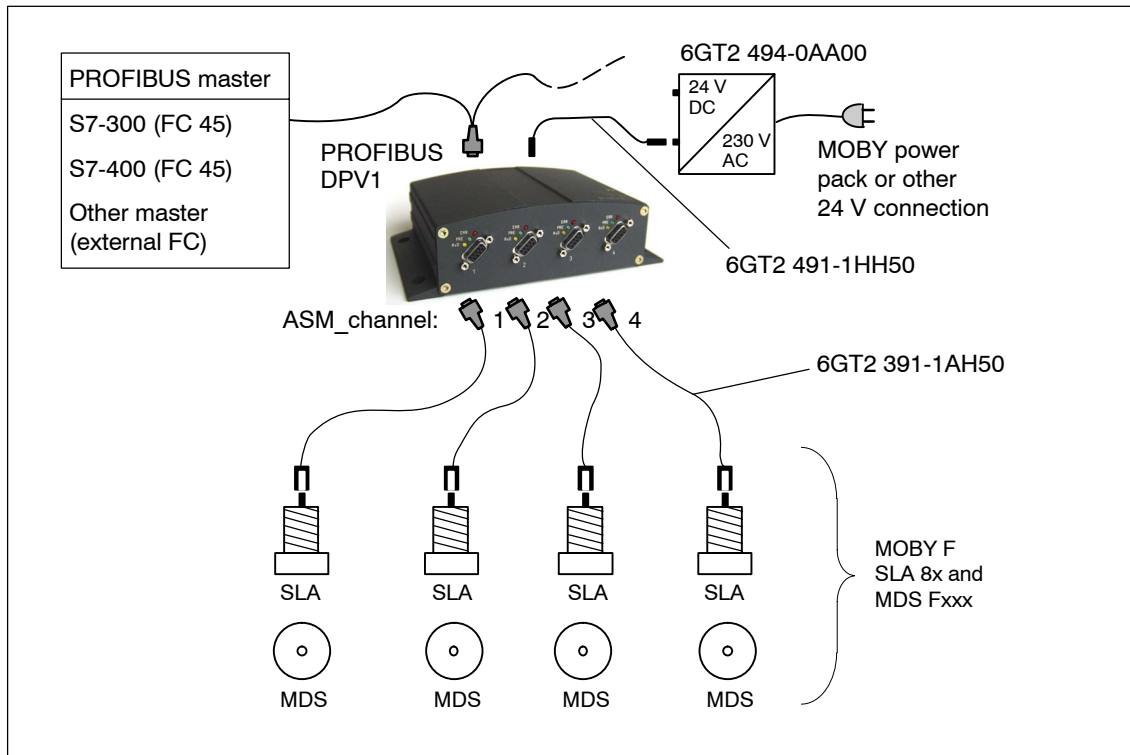

Figure 6-43 Configurator for ASM 824, ASM 850 (only with 1 x SLA 8x) and ASM 854

Technical data

Table 6-20 Technical data of the ASM 824/850/854

	ASM 850	ASM 854	ASM 824
Serial interface to user	PROFIBUS DPV1		RS 232/RS 422
Max. cable length	See PROFIBUS configuration.		30/500 m
Procedure/protocol	EN 50170, vol. 2, PROFIBUS		3964R
Connection	9-pole, submin D socket (screw lock)		
Transmission speed	9600 baud to 12 Mbaud (automatic recognition)		38.4 kbaud
Max. block length	4 words (cyclic)/238 bytes (non cyclic)		238 bytes
Serial interface to SLA	9-pole, submin. D socket (screw lock)		
Max. cable length (ASM-SLA)	Max. of 55 m		
SLAs which can be connected	1 x SLA 81	4 x SLA 81	4 x SLA 81
Software functions			
Programming	Depends on PROFIBUS DPV1 master		MOBY API: C library for PC with Win- dows 98/NT 4.0
Function block SIMATIC S7	FC 45		–
MDS addressing	Direct access via addresses		Direct access via addresses
Commands	Initialize MDS. Read data from MDS. Write data to MDS.		Initialize MDS. Read data from MDS. Write data to MDS.
Dialog	No		No
Digital inputs	None		
Digital outputs	None		
Voltage supply			
Connection plug	4-pole, M12 round plug connector (pin), not included with the ASM		
Nominal value	24 V DC		
Permissible range	20 to 30 V DC		
Current consumption	250 mA (without SLA)		
Max. switch-on current	1.1 A (without SLA)		
Ambient temperature			
During operation	–25° to +55° C (no condensation)		
During transportation and storage	–40° to +85° C (no condensation)		
Housing			
Dimensions (L x W x H) in mm	205 x 130 x 60 (without plug connector)		
Material	Aluminum		
Color	Anthracite		

Table 6-20 Technical data of the ASM 824/850/854

	ASM 850	ASM 854	ASM 824
Mounting	4 M5 screws Optional: Top hat rail mounting		
Tightening moment (at room temperature)	≤ 3 Nm		
Weight, approx.	1300 g		
Protection rating	IP40 (higher ratings on request)		
Shock in acc. w. EN 60721-3-7/class 7M2	30 g		
Vibration in acc. w. EN 60721-3-7/class 7M2	1 g (9 to 200 Hz) 1.5 g (200 to 500 Hz)		
MTBF (at +40 °C)	1 · 10 ⁵ hours		
Certification	CE		

**Pin allocations
and switches**

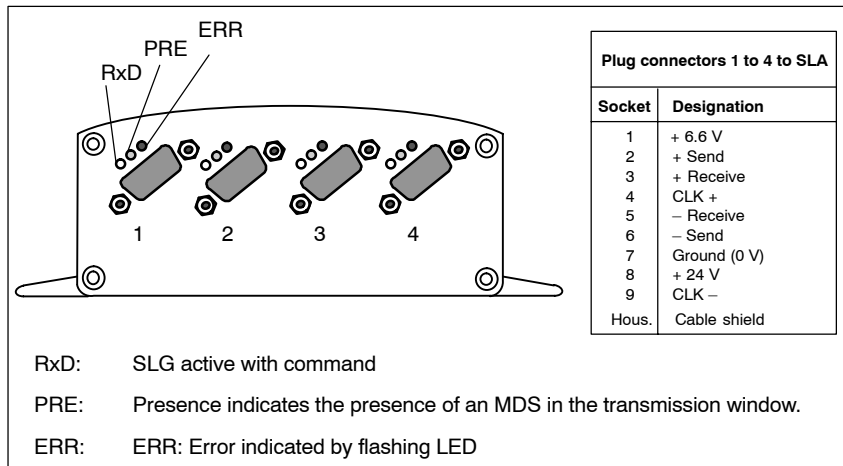

Figure 6-44 Serial interfaces of the ASM 824/850/854 to SLA 81

Only **one** SLA 81 can be connected to the ASM 850.

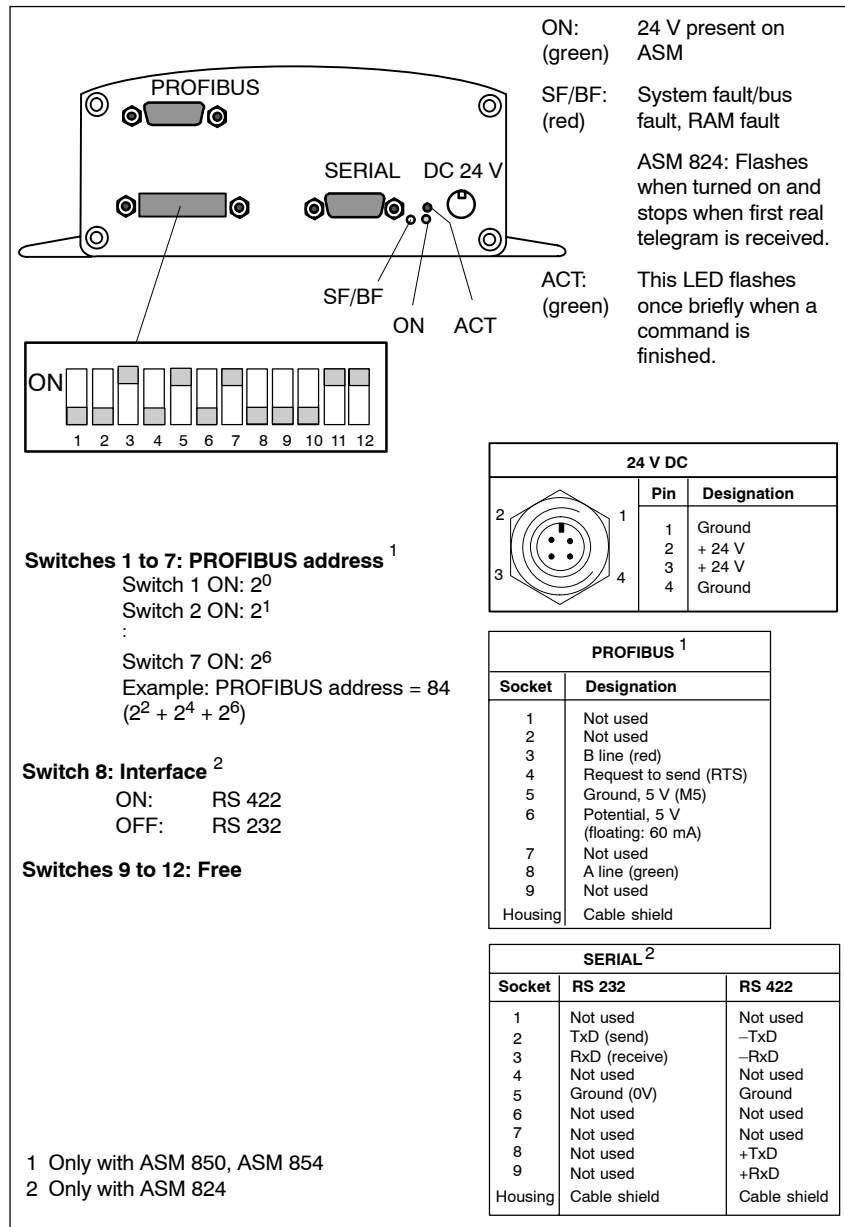

Figure 6-45 Serial interface of ASM 824/850/854 to user

**Dimensions
(in mm)**

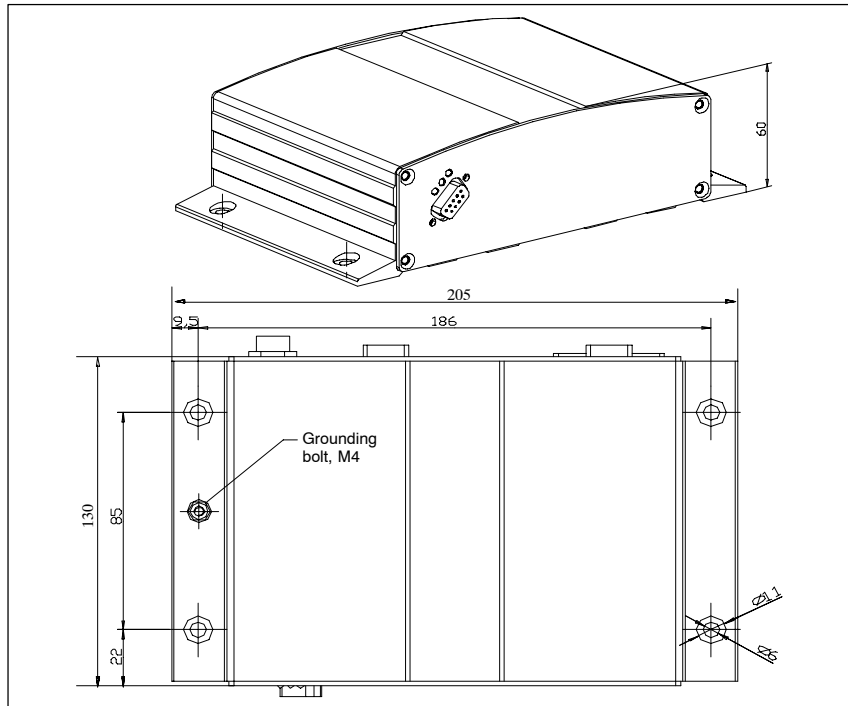

Figure 6-46 Drawing of ASM 824/850/854 with mounting holes

**Adapter floor plate
for top hat rail
mounting**

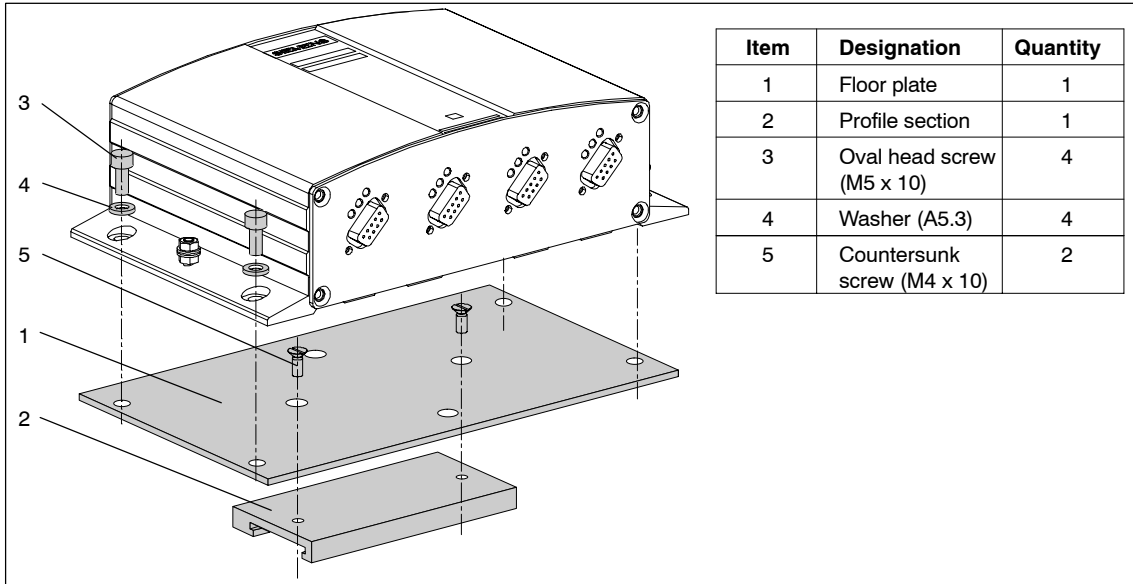

Figure 6-47 Drawing of adapter floor plate

Note

The profile section (item 2) can be turned by 90° and mounted on the floor plate to allow for adjustment to the actual situation.

6.8 Serial Interface Module – SIM

6.8.1 Overview

Application area The serial interface module (i.e., SIM) is the communication interface to almost all host computer systems, PCs, controllers of other manufacturers, and the mobile data memory (i.e., MDS).

Layout and function The serial interface module (SIM) primarily contains the components of a read/write device (SLG – see chapter 5.2, field data, table 6-24). In addition, it is equipped with an expanded communications unit. This permits reliable transmission of data and commands from the host system to the SIM.

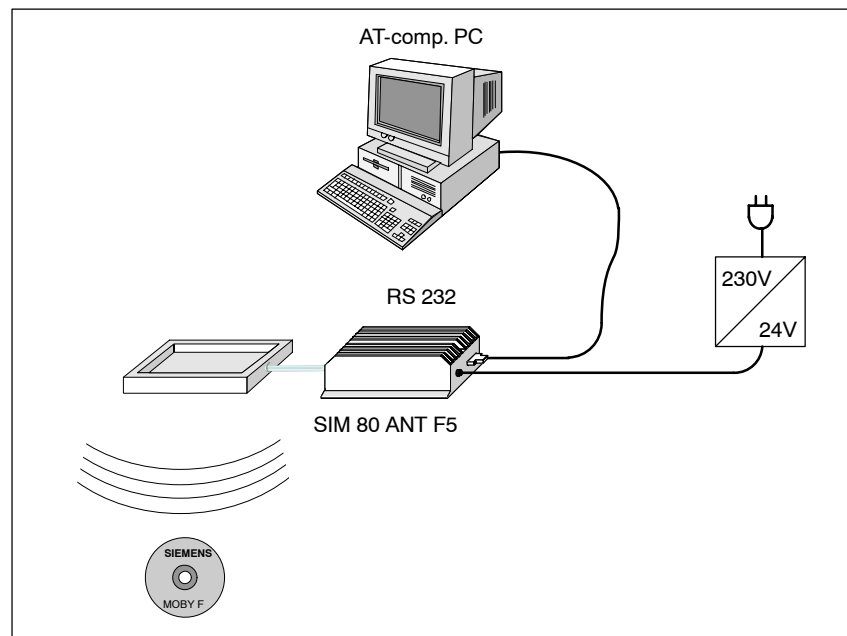

Figure 6-48 Example of a configuration for SIM

Data structure of the MOBY F data memory MDS F4xx

The 2-kbit EEPROM of the transponder is divided into 16 blocks. Each block has 4 pages. One page is the smallest unit which can be accessed. One page consists of 4 8-bit bytes.

Block access is only available for blocks 8 to 15. Page access is available for pages 1 to 63. The serial number and key A and key B cannot be read with ReadPage.

Table 6-21 Memory organization for SIM 80 ANT F5 with MDS F4xx

Block	Page	Address in Memory	Processing ¹	Access	Description
0	0	0 to 3	ro	Public	ID number (serial number, fixed code)
	1	4 to 7	r/w or ro		Configuration
	2	8 to 11	wo or 0	Secret	Key A
	3	12 to 15			Key B
1	4	16 to 19	r/w or 0		Protocol data 1B
	5	20 to 23			Protocol data 0A
	6	24 to 27		Protocol data 1A	
	7	28 to 31		Protocol data 0B	
2-3	8 to 15	32 to 63	r/w or OTP	Secret	User data
4-7	16 to 31	64 to 127	r/w or OTP	Secret or public	Read/write memory can be used as desired for user data. This area can be configured with SIM ANT F5 (password assignment).
8-15	32 to 63	128 to 255	r/w	Public	Read/write memory can be used as desired for user data. This area cannot be configured.

Areas (or settings) with light gray backgrounds can be specified by the OEM customer with the configuration page (page 1).

Table 6-22 Memory organization for SIM 82 with MDS F4xx

Block	Page	Address in Memory	Processing ¹	Access	Description
0	0	0 to 3	ro	Public	ID number (serial number, fixed code)
4-7	16 to 31	64 to 127	r/w	Public	Read/write memory which can be used as desired for user data.
8-15	32 to 63	128 to 255	r/w	Public	Read/write memory which can be used as desired for user data (block access also possible starting at address 128).

- 1 ro Read only
 - r/w Read/write
 - wo Write only
 - OTP One-time programmable memory
 - 0 Read and write not permitted
- Memory is configured with the configuration page.

Memory locations marked as “secret” cannot be accessed until both sides have proven their identities. Encrypted data communication is used for this. Memory locations marked as “public” can be accessed without both sides proving their identities. Data are not encrypted.

Block 0 contains the unique serial number (programmed during the production process), the configuration page (i.e., the configuration of the memory area) and the key. Block 1 contains the protocol data.

Blocks 4 to 7 can be configured as secret or public areas, and blocks 2 to 3 can be used as read/write or read-only areas. In addition, you can modify key and protocol data to prevent access to these data.

The configuration page itself can also be write-protected (i.e., it can be configured as a read-only area).

Be extremely careful when programming the configuration page (you can only set up write protection once) for keys and protocol data since a mistake may cause you to lose access to the secret area of the transponder.

Note

Modification of the configuration page (page 1), keys and protocol data must take place in a defined environment. While programming is being performed, the transponder may not leave the communication field of the antenna! We recommend placing the transponder in the vicinity of the antenna (no space in between) and leaving it there during programming.

Data areas which are marked as secret on the MDS F4xx can only be accessed in password mode. Access to a public page while in password mode is prevented with an error message. The mode is then automatically reset to crypto. Password mode must be re-activated before protected pages can be accessed again.

Writing the configuration with WritePage() to an MDS F4xx data memory may cause the entire data carrier to be lost. If the antenna malfunctions while the data carrier is being written, the page (4 bytes) on the data carrier is set to “FF” (FORMAT in EPROM), and the data write procedure is no longer performed. Several bits are then set to 1. The data carrier can now only be recognized with GetSnr(). All other accesses create an error.

If an error occurs during communication, the particular data memory is no longer selected. The data carrier must be selected again with GetSnr() and SelectLast().

Collision protection

There is no collision protection. More than one MDS will cause an error message. They either won't be read or they will cause a mixture of data from both MDSs.

Operating mode

The MDS F4xx is run in standard protocol mode. This mode is specified by user command and **not** in the configuration page.

The **standard protocol mode** is activated with the *GetSnr* command.

Compatibility

Since the MDS F4xx is compatible with the HITAG system, these MDSs can always be processed with the read head of the hand-held terminal.

Configuration

The configuration page has 4 configuration bytes. The first two bytes are used for the configuration while the other two bytes can be used as desired.

Configuration bytes 0 and 1

The bits in configuration bytes 0 and 1 are used to configure the memory. This is how you define which area is to be public or private, read/write, read-only or no read/write accesses at all.

You can assign the configuration page and write-access it until it is inhibited (bit 4 of configuration byte 1 is set to 0). After this byte has been write-protected once (i.e., specified as a read-only area), you can never change the configuration of the transponder memory again.

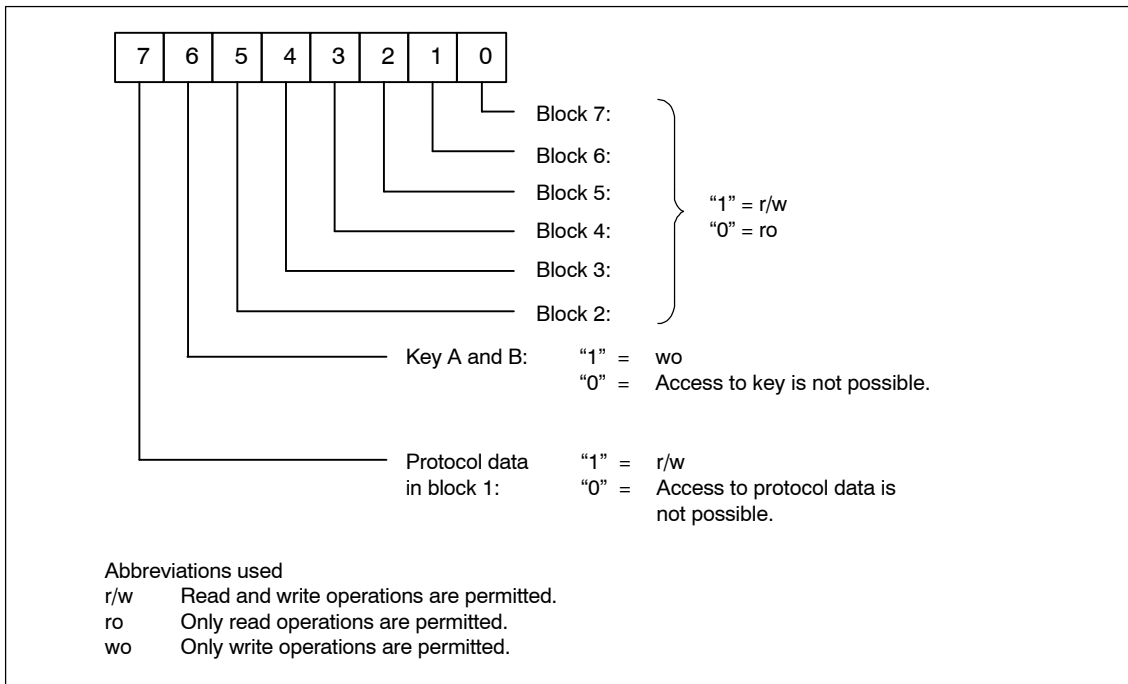

Figure 6-49 Configuration byte 0

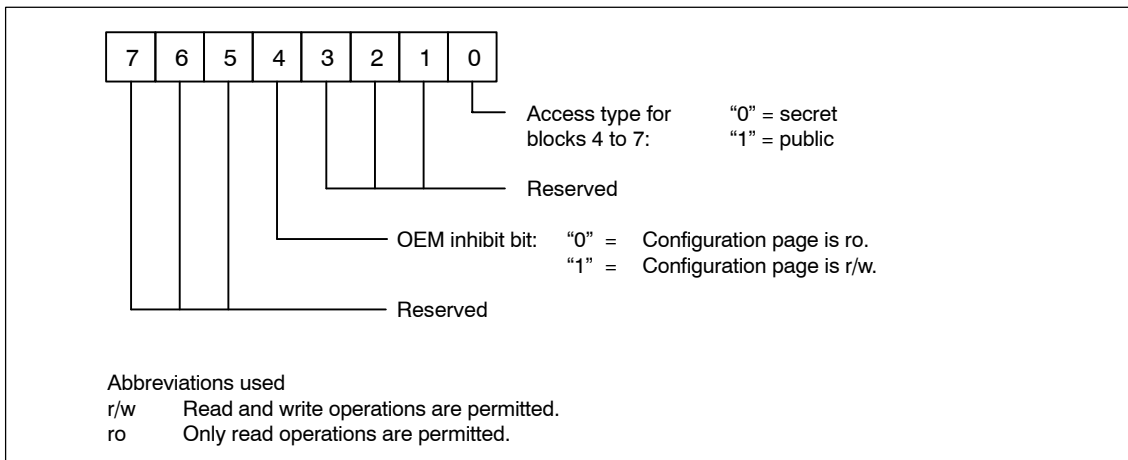

Figure 6-50 Configuration byte 1

Note

When you write a new value to configuration byte 1, do not change the bit positions marked as reserved. To meet this requirement, read the current value from configuration byte 1 and indicate the new values for the bit positions which you want to change.

Configuration bytes 2 and 3

These two bytes are also write-protected by the OEM inhibit bit (configuration byte 1/bit 4 = 0). Except for this, you can use these two bytes as desired. They have no effect on the memory configuration. For instance, OEM customers can store their own OEM serial numbers there.

Configuration of delivered MDS F4xx devices

MDS F4xx transponders are configured by Siemens with the following default configuration.

Table 6-23 Configuration of the delivered MDS F4xx transponders

	Page	MDS Address, Type	Value	Configurability
Unique serial number	0	Serial number	Write-protected	Permanently set
Configuration byte 0	1	Protocol data	'1' = r/w	Can be changed.
		Keys A/B	'1' = wo	Can be changed.
		Blocks 2 to 7	'1' = r/w	Can be changed.
Configuration byte 1	1	OEM inhibit bit	'1' = Conf. page is r/w. '1' = public	Can be changed.
		Blocks 4 to 7		Can be changed.
Value for transport key, transport protocol data	2	Key A	00 00 00 00	Can be changed, but not with the hand-held terminal read head.
	3	Key B	00 00 00 00	

Personalization

The MDS F4xx can only be personalized with the SIM 80 ANT F5 (not with the hand-held terminal read head).

Data structure of the MOBY F data memory MDS F1xx

The unique 40-bit serial number of the transponder and 24 bits for the header and parity are stored in the 64-bit memory. The data are write-protected and cannot be changed.

Since the MDS F1xx is compatible with data memory EM 4002, these data memories can also be read with the read head of the hand-held terminal.

Field data of MDS and SIM

The following table shows the field data of all MOBY F components of the MDS and SIM. The information in the table makes it particularly easy to select the correct MDS and SIM.

All technical data are typical data and are valid at an ambient temperature of 0° to +50° C, a supply voltage of 22 V to 27 V DC, and a metal-free environment. **Tolerances of $\pm 20\%$ are permitted due to manufacturing and temperature factors.**

Additional tolerances apply to the field data when the total voltage range of 20 V to 30 V DC is utilized on the SIM and/or the total temperature range is utilized on the MDS and SIM.

Table 6-24 Field data of all MDSs and SIMs without effects of metal

MDS SIM	MDS F124	MDS F125	MDS F160	MDS F415
Length of the transmission window in mm (L)				
SIM 80 ANT F5	280	280	230	280
SIM 82	Ø 70	Ø 70	Ø 40	Ø 70
Width of the transmission window in mm (W)				
SIM 80 ANT F5	110	110	92	110
SIM 82	30	30	16	30
Working distance in mm (S_a)				
SIM 80 ANT F5	0 to 240	0 to 380	0 to 140	0 to 300
SIM 82	0 to 65	0 to 110	0 to 60	0 to 90
Limit distance in mm (S_g)				
SIM 80 ANT F5	280	420	160	340
SIM 82	80	140	70	110

Note

For effects of metal on the transmission window, see chapter 3.4.2.

Table 6-25 Minimum distance from MDS to MDS

	MDS F124	MDS F125	MDS F160	MDS F415
SIM 80 with ANT F5	≥ 1 m	≥ 1 m	≥ 1 m	≥ 1 m ¹
SIM 82	≥ 0.3 m	≥ 0.4 m	≥ 0.3 m	≥ 1 m

¹ The minimum distance can be reduced for SIM 80 ANT F5 in multi-tag operation. The MDSs may be located next to each other, but overlapping is not permitted.

Table 6-26 Minimum distance from antenna to antenna with MDS F4xx (r/w)

	SIM 80 with ANT F5	SIM 82
SIM 80 with ANT F5	≥ 5 m	≥ 2 m
SIM 82	≥ 2 m	≥ 1.2 m

Table 6-27 Minimum distance from antenna to antenna with MDS F1xx (r/o)

	SIM 80 with ANT F5	SIM 82
SIM 80 with ANT F5	≥ 1.5 m	≥ 1 m
SIM 82	≥ 1 m	≥ 0.4 m

Note

The values listed in tables 6-26 and 6-27 must be adhered to. Non-adherence would affect the inductive fields. Data transmission time would increase to an unknown value, or a command would be terminated with errors. A test is recommended in critical applications.

6.8.2 Cable and Plug Connector Allocation

The 9-pole subminiature D plug connector (pin on device side) is used for the following purposes.

- Connection to the PC/computer
- Connection of the input and output

Plug connector on SIM 80 ANT F5

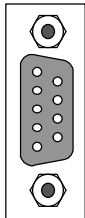

9-pole submin D plug connector with screw-type lock

Table 6-28 Plug connector allocation of the 9-pole submin D (pin housing side)

Pin	Designation RS 232
1	Cable shield
2	TxD (Send)
3	RxD (Receive)
4	Digital input ²
5	Ground (0V)
6	Not used
7	Not used
8	Cable shield
9	Digital output (24 V DC, max. 0.5 A ohmic load) ¹

1 Logical “0”: < 2 V on 50 Ω / logical “1”: 22 V on 50 Ω
 2 Logical “0”: – 2 V < log 0 < 0.8 V / logical “1”: 3 V < log 1 < 30 V



Caution

If metallized sub D housings are used on the SIM side, the housing must be connected to the cable shield.

"SERIAL" plug connector on SIM 82

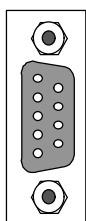

9-pole submin D plug connector with screw-type lock

Table 6-29 Plug connector allocation of the 9-pole submin D (socket housing side)

Socket	Designation	
	RS 232	RS 422
1	Not used	Not used
2	TxD (send)	D- (send)
3	RxD (receive)	E- (receive)
4	Not used	Not used
5	Ground (0 V)	Ground (0 V)
6	Not used	Not used
7	Not used	Not used
8	Not used	D+ (send)
9	Not used	E+ (receive)
Housing	Cable shield	Cable shield

Table 6-30 Plug connector allocation of the 9-pole submin D¹ (socket housing side)

Plug connector on SIM 82

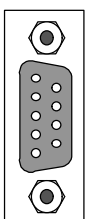

9-pole submin D plug connector with screw-type lock

Socket	Designation
1	+6.6 Volt
2	+ Send
3	+ Receive
4	CLK +
5	- Receive
6	- Send
7	Ground (0 V)
8	+24 Volt
9	CLK -
Housing	Cable shield

1 This plug connector allocation is valid for SIM 82 <=> SLA 81.

SLA 81

Plug connector on SLA 81

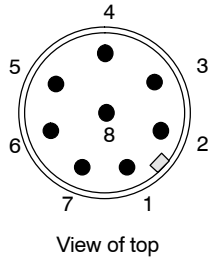

Table 6-31 Plug connector allocation of SLA plug connector¹ (pin housing side)

Pin	Designation
1	+6.6 Volt
2	+ Send
3	+ Receive
4	CLK +
5	- Receive
6	- Send
7	CLK -
8	Ground (0 V)

1 This plug connector allocation is valid for SLA 81 <=> SIM 82.

Voltage supply plug connector on SIM 80/82

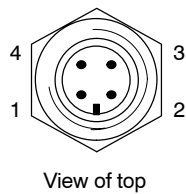

Table 6-32 Plug connector allocation of 4-pole voltage supply plug connector (pin housing side)

Pin	Designation
1	Ground (0 V)
2	+ 24 V
3	+ 24 V
4	Ground (0 V)

Voltage supply – SIM

The voltage supply of the SIM is provided by a 4-pole plug connector. **It is essential to consider the voltage drop on the supply cable.** The permissible length of the voltage supply cable depends on the current consumption of the SIM and on the ohmic resistance of the connection cable.

Table 6-33 Voltage supply of the SIM

	SIM 80 ANT F5	SIM 82
Nominal value	24 V DC	24 V DC
Permissible range	20 to 30 V (as measured on the plug connector of the SIM)	20 to 30 V (as measured on the plug connector of the SIM)
Current consumption		
Startup current	1.5 A	1.1 A
At 24 V	0.6 A (without DO) 1.1 A (with DO)	0.25 A –

Table 6-34 Max. ripple of the supply voltage for SIM 80 ANT F5 (based on frequency range)

f_{ripple} (kHz)	U_{ripple max.} (mV RMS)
f _{ripple} < 0.5	48
0,5 ≤ f _{ripple} < 20	7
20 ≤ f _{ripple} < 120	36
120 ≤ f _{ripple} < 130	12
f _{ripple} > 130	48

Note**For SIM 80 ANT F5**

When a switching power pack is used, make sure that the switching frequency is in the range of 160 kHz < f_{switch} < 200 kHz.

Standard cabling for SIM 80 ANT F5 with the RS 232 interface

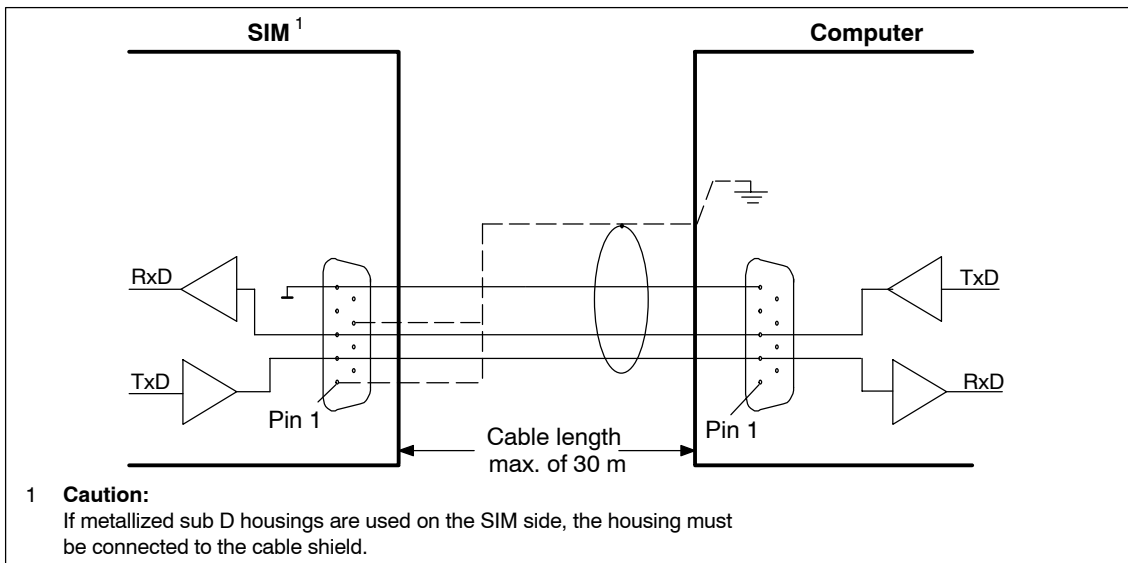

Figure 6-51 Standard cabling for computer/SIM 80 ANT F5, RS 232

Standard cabling for SIM 82 with RS 232 interface

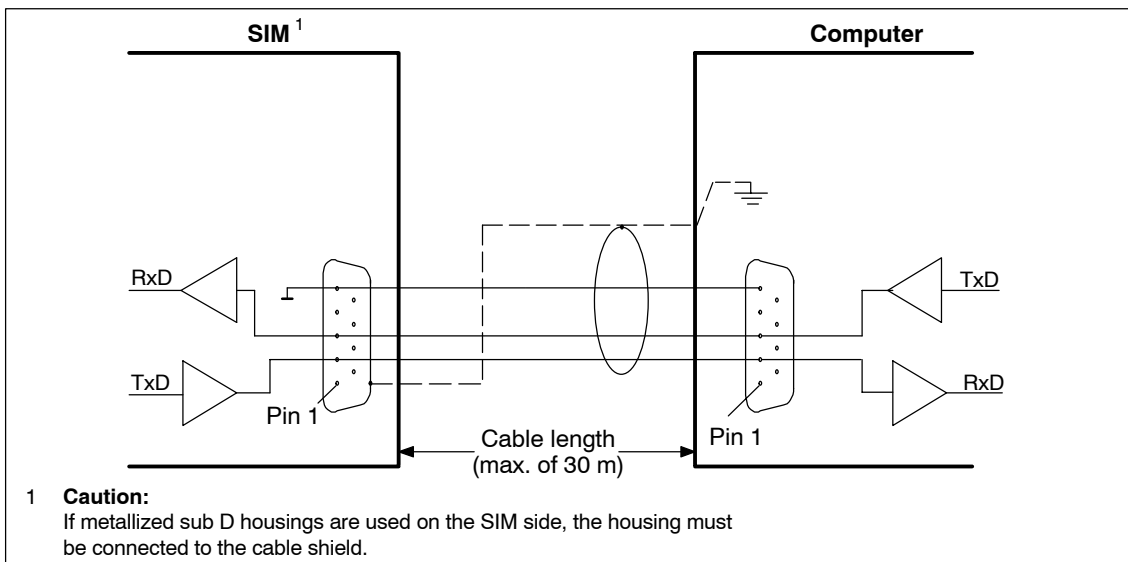

Figure 6-52 Standard cabling for computer/SIM 82, RS 232

The SIM is equipped with a standard RS 232 (V.24) interface with the signal lines on pins 2 and 3. V.24 controller lines (e.g., DSR, DTR, RTS and CTS) are not supported by SIM. Acknowledgment of the data is performed at the procedure level.

**Standard cabling
for SIM 82 with
RS 422 interface**

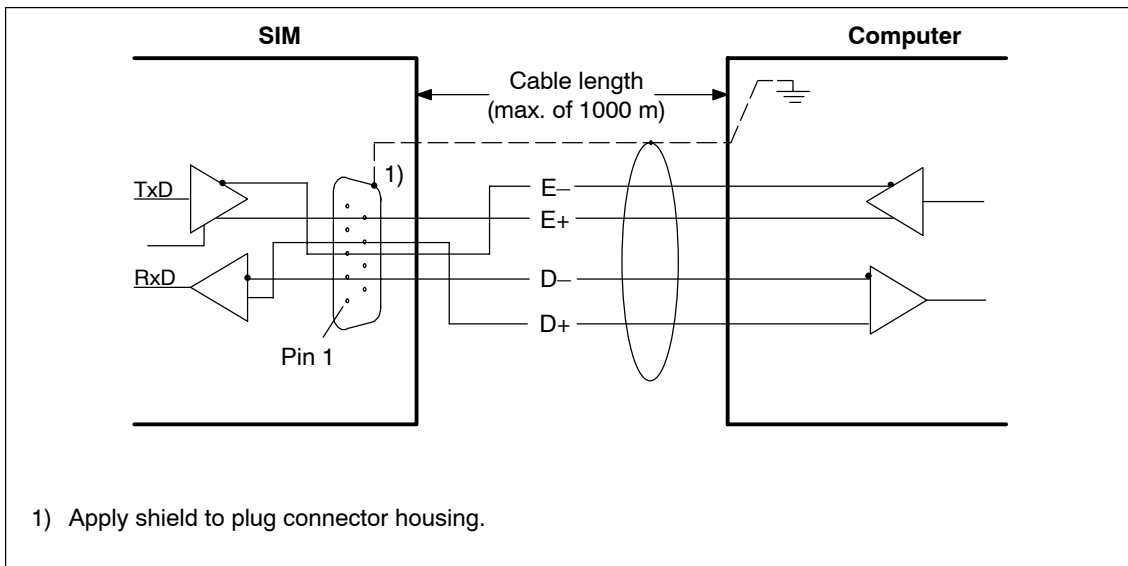

Figure 6-53 Standard cabling for computer/SIM 82, RS 422

**DI/DO cabling
for SIM 80 ANT F5
with voltage
supply**

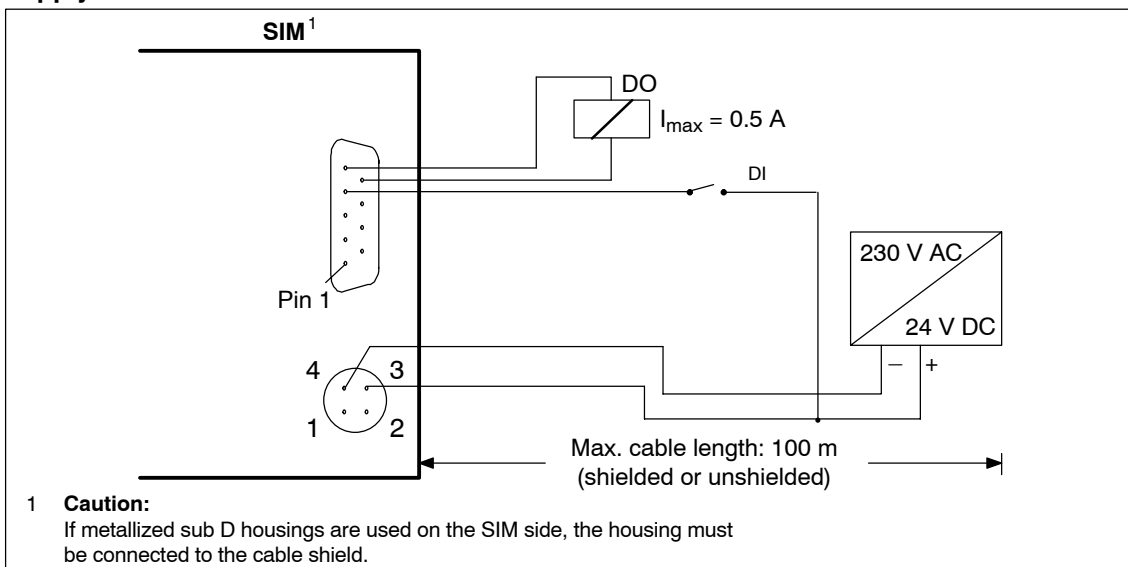

Figure 6-54 DI/DO cabling with voltage supply for SIM 80 ANT F5

6.8.3 Programming the SIM Module

Communication on the serial interface between the SIM and the host computer system is handled by the ASCII protocol. The telegrams are protected with a BCC (i.e., Block Check Character). For a description of the protocol, see the applicable programming guide.

A C library (MFWAPI for Windows 95/NT 4.0) and programming guide (see chap. 7.1) are available to the user for the computer.

PC user

The SIM is connected to a serial interface of the computer.

Windows 95/NT 4.0 users use PC interface COM1 and/or COM2. Using additional hardware, 4 interfaces can be provided. Can be run on PC models starting with processor 80486 SX with serial interface and a Windows 95/NT 4.0 operating system.

For computers which do not use Windows (e.g., UNIX), see the communication specifications from the Windows 95/NT 4.0 programming guide. See appendix A for order number.

What do I do if nothing works ?

- a) Check supply voltage with a measuring instrument directly on the SIM plug connector.
- b) Check the cabling to the computer.
 - Do SIM and computer have the same physical interface?
 - Is the polarity of the connection cable (RS 232 or RS 422) correct? RxD of SIM must be connected to TxD of computer, or vice versa.
 - Is the cable shield correctly installed?

Error messages

The error messages are described in the individual programming guides.

Distance to SIM is too short

When the distance to the SIM is too short, check the following.

- Power pack/switching power pack (see chap. 3.5 for interference)
- Are monitors or other sources of interference in the vicinity (see chap. 3.5)?
- Is metal in the immediate vicinity (see chap. 3.4)?

6.8.4 SIM 80 ANT F5

Application area

The SIM 80 with ANT F5 meets the primary technical requirements of the SLG 80 with ANT F5. Use of an ASCII protocol for communication permits the use of computer systems, PCs and controllers of other manufacturers.

In addition, the SIM 80 permits use of the expanded functions of the EEPROM-MDS (MDS F4xx) such as selective read and write-accesses to several MDSs in the transmission window (i.e., pileup recognition and multi-tag function). The EEPROM-MDS (MDS F4xx) also offers cryptographic and password functions for data protection. These functions can only be used in combination with the SIM 80. See appendix A of the programming guides.

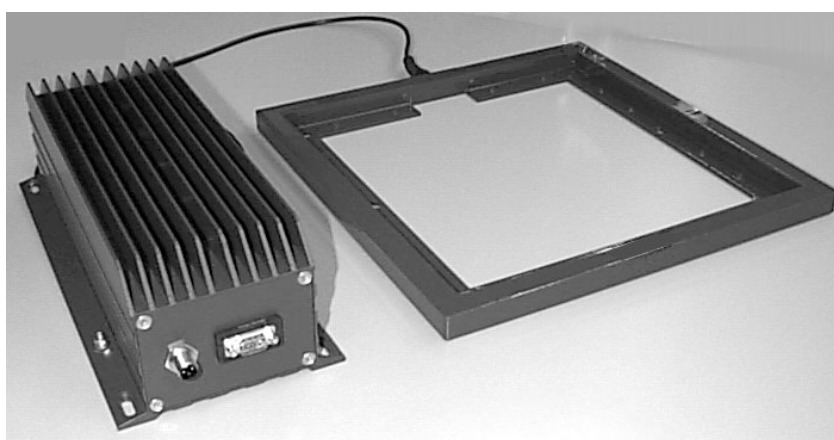

Figure 6-55 SIM 80 ANT F5 serial interface module

Ordering data

Table 6-35 Ordering data for the SIM 80 ANT F5

SIM 80 ANT F5 serial interface module (Counter plug for supply voltage is included.)	6GT2 405-0AF00
Stub lines and accessories	See chapter 3.7.
Software	See chapter 7.1.
Programming guide	See appendix A.

Technical data

Table 6-36 Technical data of SIM 80 ANT F5

Inductive interface to MDS Max. read/write distances, SIM-MDS Transmission frequency	420 mm (see field data) 125 kHz
Serial interface Procedure Data transmission speed Data line length (max.) Line length, antenna ¹	RS 232 ASCII protocol 9600 baud 30 m 2 m (can be plugged in on SIM side)
Software functions Programming C libraries available for PC	Read, write, initialize MDS, access rights and multi-tag. See programming guide. Depends on computer, PC or PLC of other manufacturer MFWAPI (for Windows 95/NT 4.0)
Supply voltage (via separate power plug connector) Nominal value Permissible range	24 V DC, linear regulated power pack or clock-pulsed switching power pack (160 to 200 kHz) 20 to 30 V DC
Current consumption at room temperature without DO Switchon current, brief Operation (at 24 V)	Max. of 1.5 A 600 mA (typical)
Digital inputs	1
Digital outputs	1
MTBF	1 x 10 ⁵ hours
Housing Dimensions (in mm) For antennas (L x W x H) For electronics w/o plug (L x W x H) Color Antenna SLG housing Material Antenna SLG housing Plug connection (data) Plug connection (Supply voltage: counter plug is included with the SIM.)	350 x 350 x 20 320 x 145 x 100 Anthracite Anthracite Aluminum Aluminum 9-pole submin plug connector (pin on device side) M12 4-pole device plug connector (IP65)

Table 6-36 Technical data of SIM 80 ANT F5

Protection rating in acc. w. EN 60529	
SIM housing	IP65 ²
Antenna	IP65
Shock in acc. w. EN 60721-3-7, class 7M2	30 g
Total shock-response spectrum, type II	
Vibration in acc. w. EN 60721-3-7, class 7M2	1 g (9 to 200 Hz) 1.5 g (200 to 500 Hz)
Mounting of SIM	4 M6 screws
Mounting of antenna	Min. of 4 M6 screws
Turning moment (at room temperature)	≤ 3 Nm
Ambient temperature	
During operation	–25° to +60° C
During transportation and storage	–40° to +85° C
Weight (SIM)	Approx. 3600 g
Weight (antenna)	Approx. 1200 g

1 Note:

The antenna is prefabricated. Any changes to the cable will cancel the warranty and the CE/BZT certification.

2 IP65 with special plug 6GT2 490-1AA00 (see chap. 7.2)

Field data

Table 6-37 Field data of SIM 80 ANT F5

Operating distance (S_a)	0 to 380 mm (See table 6-24.)
Limit distance (S_g)	420 mm (See table 6-24.)
Transmission window (L)	280 mm (See table 6-24.)
Minimum distance from ANT F5 to ANT F5 (D)	See figure 6-58.

FCC information



Warning

Do not make changes on the devices.
Violation will invalidate interference emission certification (FCC) and the manufacturer's warranty.

Note

This equipment has been tested and found to comply with the limits for a Class B digital device, pursuant to Part 15 of the FCC Rules. These limits are designed to provide reasonable protection against harmful interference in a residential installation. This equipment generates, uses and can radiate radio frequency energy and, if not installed and used in accordance with the instructions, may cause harmful interference to radio communications. However, there is no guarantee that interference will not occur in a particular installation. If this equipment does cause harmful interference to radio or television reception, which can be determined by turning the equipment off and on, the user is encouraged to try to correct the interference by one or more of the following measures:

- Reorient or relocate the receiving antenna.
 - Increase the separation between the equipment and receiver.
 - Connect the equipment into an outlet on a circuit different from that to which the receiver is connected.
 - Consult the dealer or an experienced radio/TV technician for help.
-



Caution

Use of a shielded cable for any kind of connection cable is absolutely necessary.
The cable shield must be secured with a shield clamp directly on the interface module and grounded via a grounding rail.

Transmission window

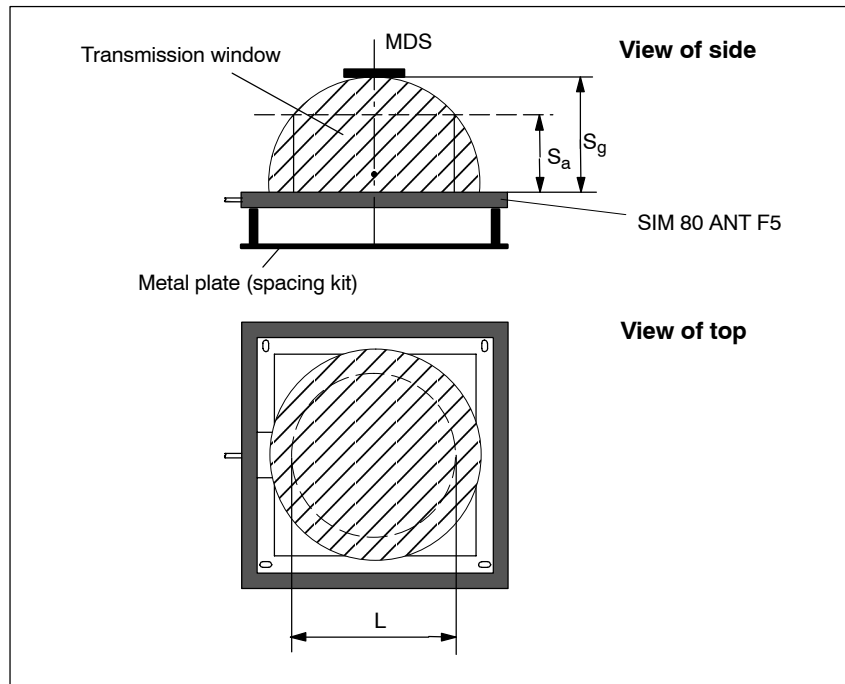

Figure 6-56 Transmission window of the SIM 80 ANT F5

Metal-free space

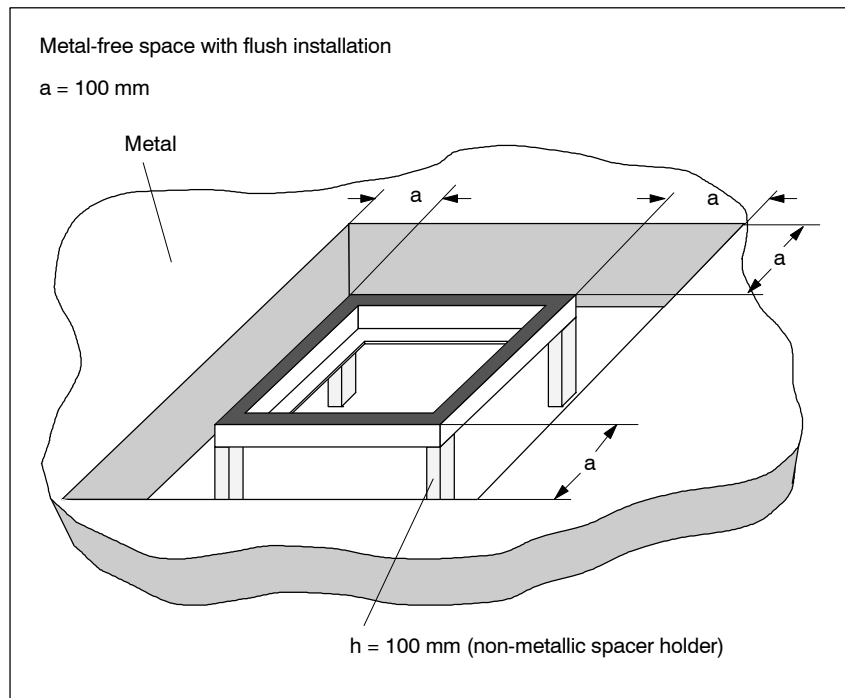

Figure 6-57 Metal-free space for SIM 80 ANT F5

Definition of distance D

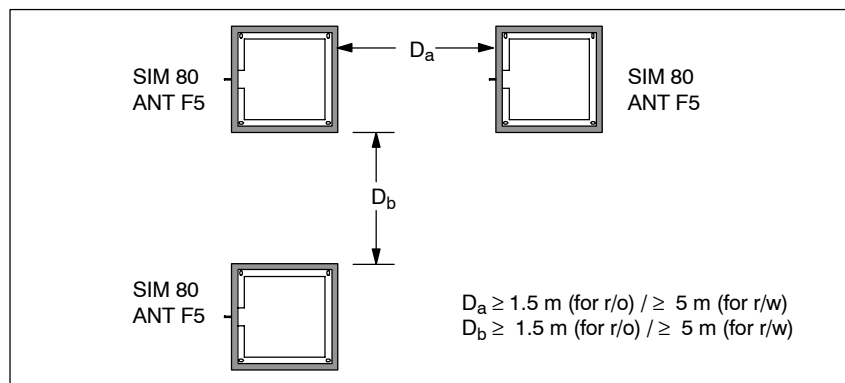

Figure 6-58 Distance D for SIM 80 ANT F5

**Dimensions
(in mm)**

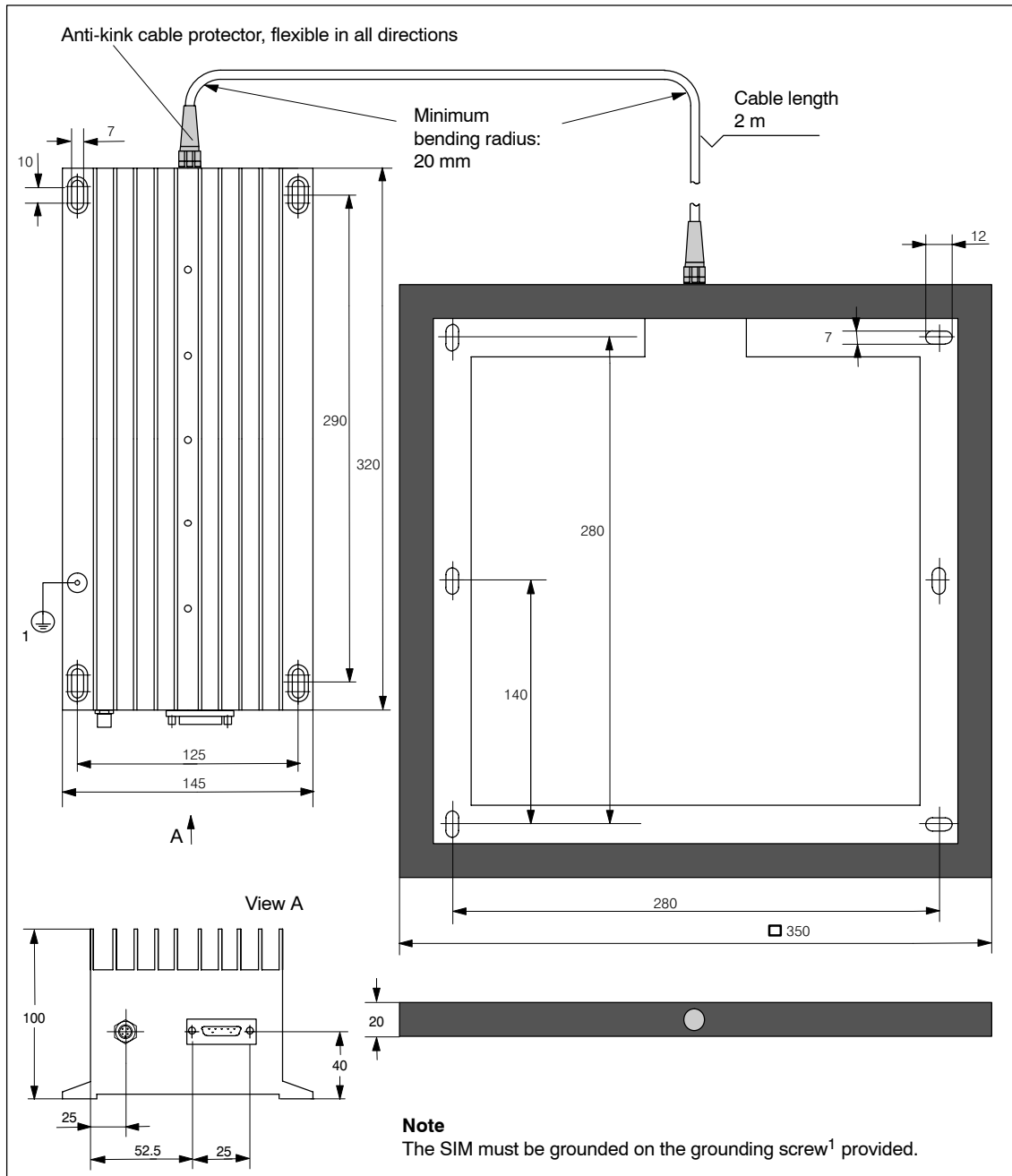

Figure 6-59 Dimensional diagram of SIM 80 ANT F5

**Spacer Kit for
MOBY F ANT F5**

See chap. 5.2.

6.8.5 SIM 82

Application area

The SIM 82 is a serial interface module in the medium–end performance range with a remote antenna. An ASCII protocol for communication permits use with computer systems, PCs and controllers of other manufacturers. The maximum cable length between antenna and evaluation unit is 55 m. The antenna head can be positioned very precisely for every application with the two screw nuts. The SIM 82 can be run on PC, SICOMP and controllers of other manufacturers. The connection cable from the antenna to the evaluation unit is included with the SIM 82 (length: 5 m).



Figure 6-60 Serial interface module SIM 82

Ordering data

Table 6-38 Ordering data for SIM 82

SIM 82 serial interface module with serial interface RS 232/RS 422; ASCII protocol for PC, SICOMP and other controllers; with one SLA 81.	6GT2 405-2CB00
Stub lines and accessories	See chapter 3.7.
Programming guide	See appendix A.
Software	See chapter 7.1.

Technical data

Table 6-39 Technical data of SIM 82

Inductive interface to the MDS	
Read/write distances, SIM-MDS, max.	140 mm (see field data)
Transmission frequency	125 kHz
Serial interface to computer	RS 232/RS 422
Procedure	ASCII protocol
Data transmission speed	9600 baud
Data line length to computer, max.	30 m

Table 6-39 Technical data of SIM 82

Line length to antenna	Max. of 55 m (can be connected on both sides)
Software functions MDS addressing Commands Programming The following C libraries are available for the PC Dialog	Direct access via addresses Read, write, initialize MDS Special functions (e.g., access rights, multi-tag) are not available for the SIM 82. See programming guide. Depends on computer, PC, PLC of other manufacturer MFWAPI (for Windows 95/NT 4.0) No
Digital inputs Digital outputs	None None
Voltage supply Nominal value Permissible range Current consumption Switch-on current, brief Operation (with 24 V DC)	Via separate power plug (not included with the SIM 82) 24 V DC 20 to 30 V DC Max. of 1.1 A 250 mA (typical)
MTBF (at +40 °C)	1 x 10 ⁵ hours
Housing Dimensions (in mm) Antenna with threading and plug (Ø x L) Threading on plug side (Ø x incline x L) Electronics without plug (L x W x H) Color Antenna SIM housing Material Antenna SIM housing Plug connection Data Electronics ↔ antenna Voltage supply	65 x 90 M30 x 1.5 x 40 205 x 130 x 60 Anthracite/pastel turquoise Anthracite Krastin Aluminum 9-pole, submin. D plug connector (socket on device side) 9-pole, submin. D plug connector on SIM housing (socket) 8-pole M12 on antenna (pin) 4-pole M12 on SIM housing (pin)
Protection rating in acc. w. EN 60529 SIM housing Antenna Shock in acc. w. EN 60721-3-7/class 7M2 Total shock-response range, type II Vibration in acc. w. EN 60721-3-7/ class 7M2	IP40 (higher ratings on request) IP65 30 g 1 g (9 to 200 Hz) 1.5 g (200 to 500 Hz)

Table 6-39 Technical data of SIM 82

Mounting of SIM	4 M5 screws
Tightening moment at 20° C	≤ 3 Nm
Mounting of antenna	2 plastic nuts, M30 x 1.5
Ambient temperature	
Antenna During operation	-25° C to +70° C
During transportation and storage	-40° C to +85° C
SIM housing During operation	-25° C to +55° C (no condensation)
During transportation and storage	-40° C to +85° C (no condensation)
Weight (without connection cable)	
SIM	1300 g
Antenna	150 g

Field data

Table 6-40 Field data of SIM 82

Working distance (S_a)	0 to 110 mm
Limit distance (S_g)	140 mm
Diameter of transmission window (L_d)	∅ 70 mm
Minimum distance from SLA to SLA (D)	See figure 6-63.

Transmission window

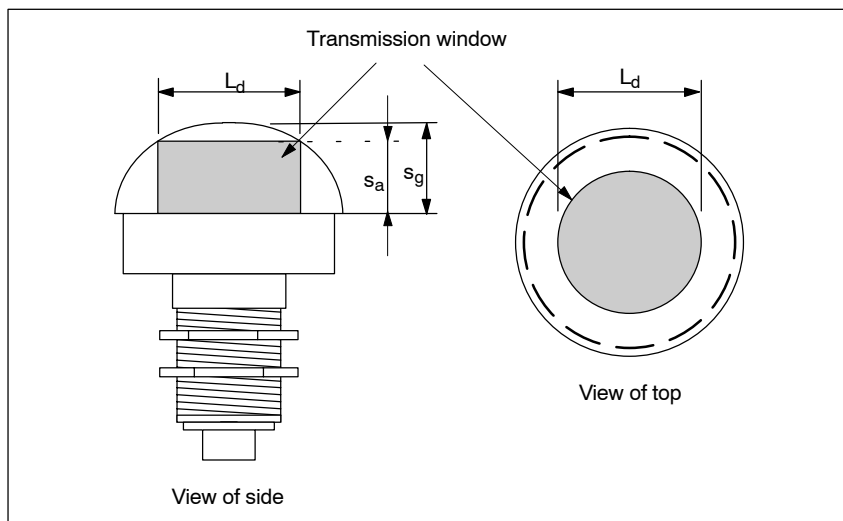

Figure 6-61 Transmission window of SIM 82

Metal-free space

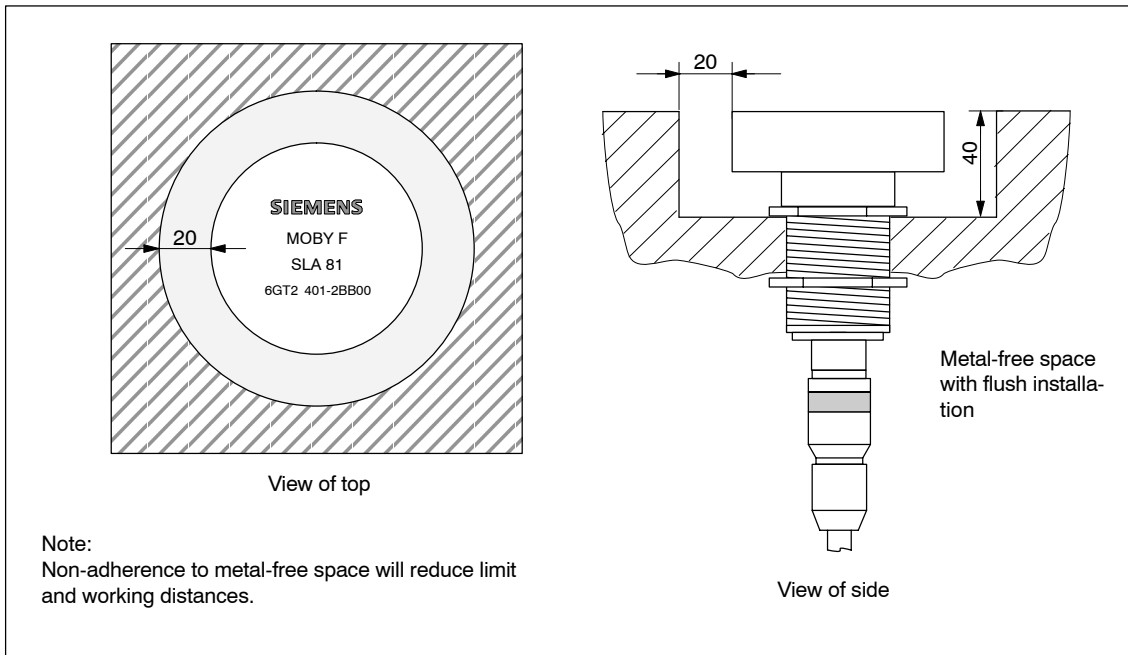

Figure 6-62 Metal-free space for SIM 82

Definition of distance D

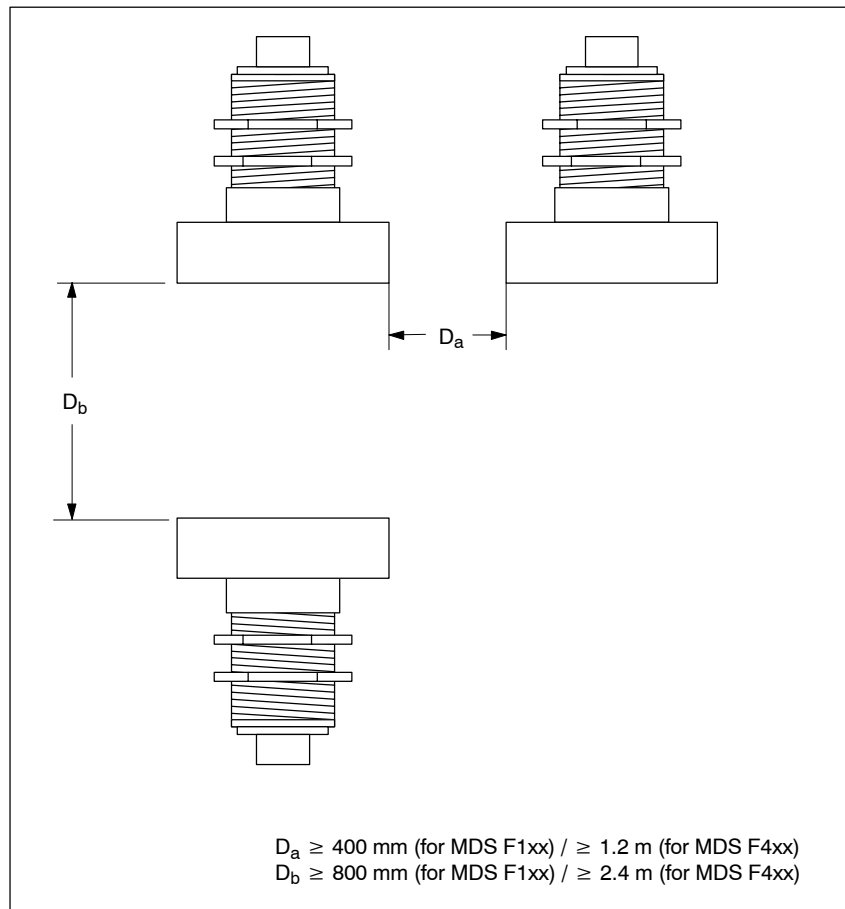

Figure 6-63 Distance D: SIM 82

Pin allocations and switches

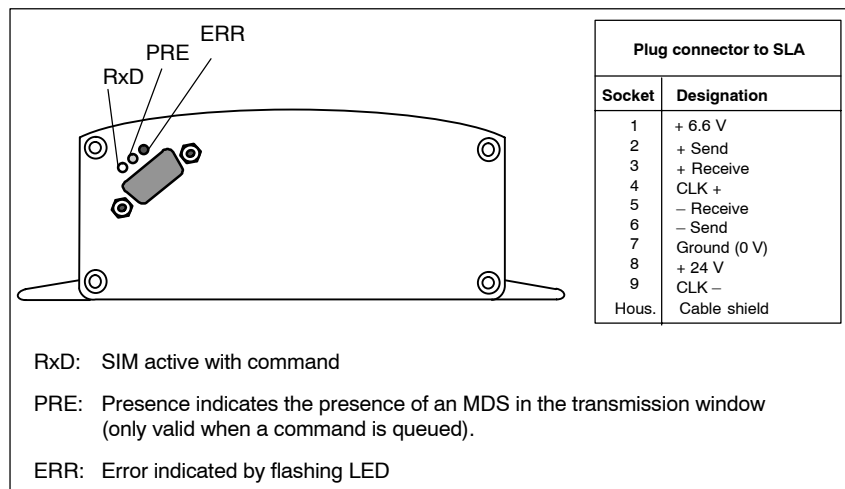

Figure 6-64 Serial interface of SIM 82 to SLA 81

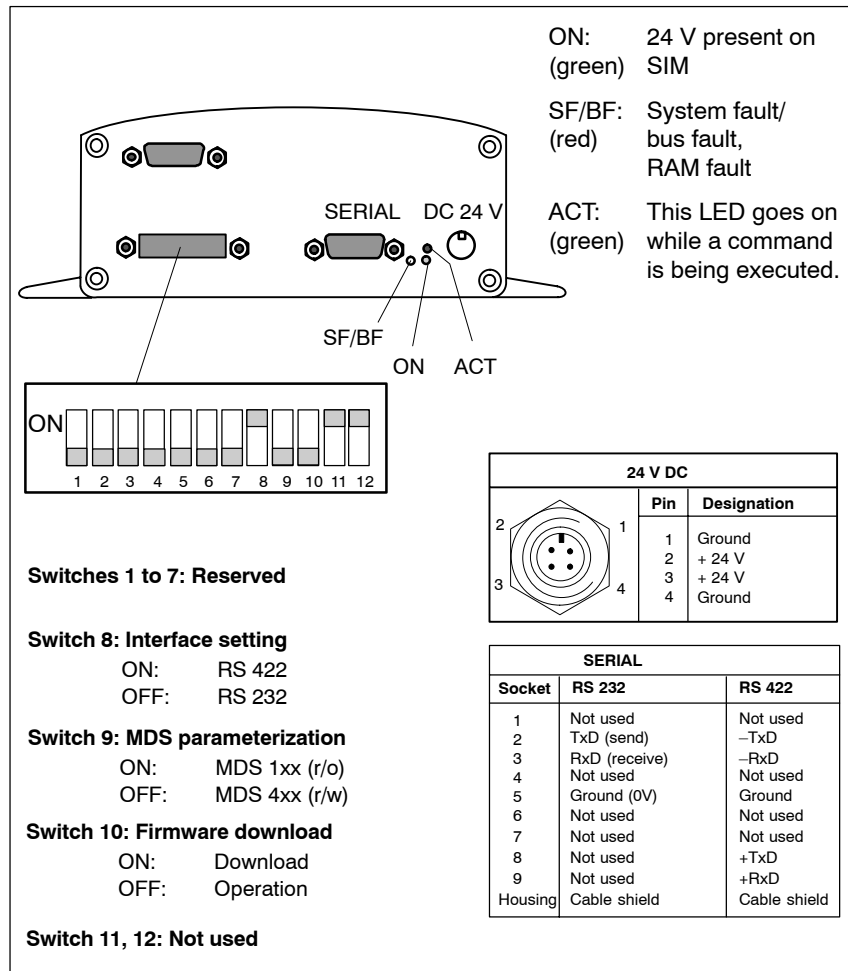

Figure 6-65 Serial interface of SIM 82 to user

**Dimensions
(in mm)**

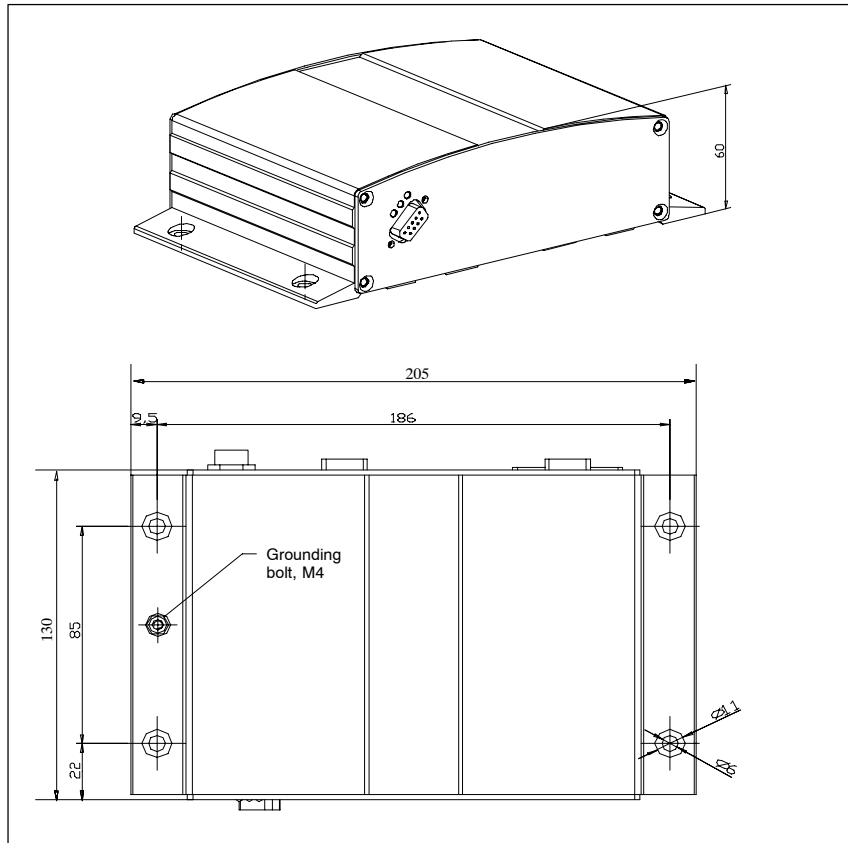

Figure 6-66 Dimensional drawing of the SIM 82 housing

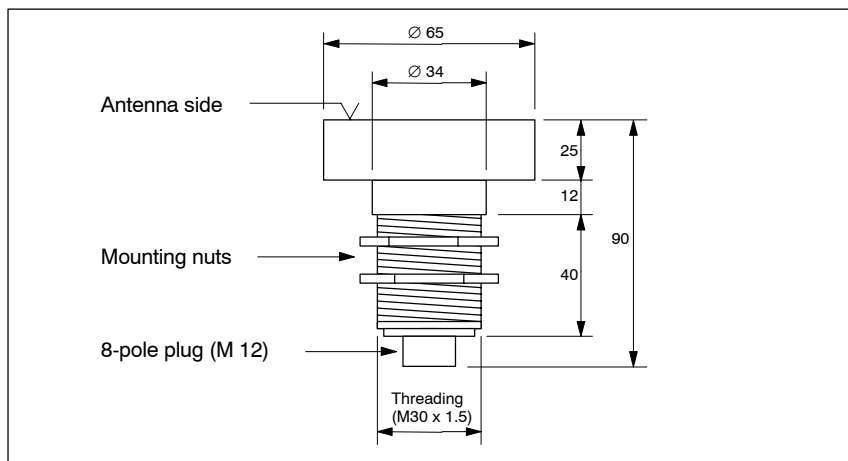

Figure 6-67 Dimensional drawing of antenna for SIM 82 (SLA 81)

Adapter floor plate for top hat rail mounting

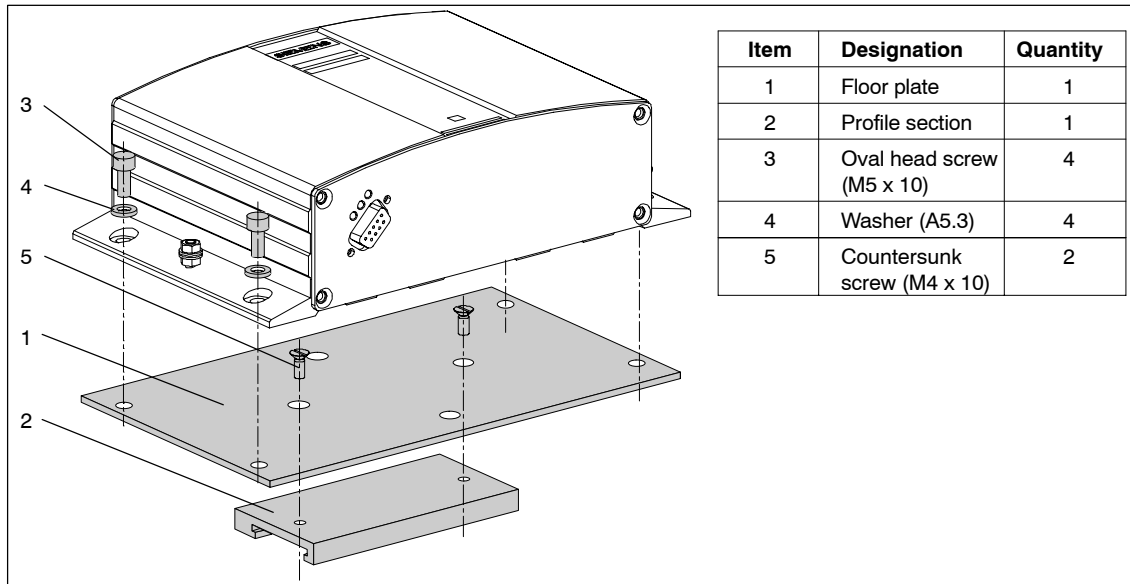

Figure 6-68 Drawing of mounting of adapter floor plate

Note

The profile section (item 2) can be turned by 90° and mounted to allow for adjustment to the actual situation.

Accessories

7

7.1 MOBY Software

Starting with version 3.0, the “MOBY Software” product is delivered on a CD. All function blocks and drivers for MOBY are included. The “Les_mich” (i.e., read_me) file on CD gives a brief explanation of the programs listed below.

- FB 240: Function block for ASM 450; MOBY on PROFIBUS DP with SIMATIC S5 (including master device file for PROFIBUS DP)
- FB 250: Function block for ASM 400
- FB 41 contains a function block for the ASM 410. The call interface of this function block is almost identical to that of FB 250. See the description of FB 250 for programming.
- FC 44 permits the ASM 450 to be used in a SIMATIC S7 environment. Be sure to read the “Read_me” file in the FC 44 directory carefully. See description of “FC 44 for ASM 450” for use of the ASM 450.
- FC 45: S7 function for ASM 850, ASM 854
- Function FC 47 for ASM 470
- FB 47 contains a function block for the SIMATIC S5-115U to 155U. It permits the ASM 470 to be used in a SIMATIC S5 environment with an ET 200M.
- Test and demonstrator programs for presenting the functions (e.g., “read from MDS”, “write to MDS” and so on) on a PC (Windows). MOBY modules ASM or SIM are connected by a cable (serial interface) to the PC (i.e., COM1 or COM2).
- Brief explanations of the individual directories in German or English. Cf. “les_mich.txt” or “read_me.txt”.
- 3964R driver for DOS, Windows 95 and Windows NT
- C library (MFWAPI) for Windows 95/NT 4.0 (for SIM 82/SIM 80 ANT F5)
- C library (MOBY API) for Windows 98/NT 4.0 (for ASM 824)
- Latest version of MOBY documentation as PDF file
- Tools. Helpful programs for the MOBY configuration

Operator guide

The “Software MOBY” CD contains a user-friendly operator guide based on HTML. After Start.exe is called, a screen appears with the following main items in the top menu line.

- FC for S7
- FB for S5
- PC Support
- Docu
- Tools
- Demo
- News

Note**Information on MOBY software or licensing**

The purchase price of an interface module or SIM does not include software or documentation. The “**Software MOBY**” **CD-ROM** which includes all available FBs/FCs for SIMATIC, C libraries for Windows 98/NT, demo programs, and so on **must be ordered separately**. Furthermore, the CD-ROM contains the complete MOBY documentation (in German, English and French) in PDF format.

The purchase price of an interface module or SIM includes the price for utilization of the software including documentation on the “Software MOBY” CD-ROM, and the purchaser is granted the right to make copies (copy license) to the extent required by the customer-specific application or development for the system.

In addition, the enclosed contract covers the use of software products in return for a one-time payment.

**C library,
MFWAPI for
SIM 80/82**

The import library is written in C++.
The following functions are supported.

- Read MDS
- Initialize MDS
- Write MDS
- Password protection and access rights (not SIM 82)
- Multi-tag recognition (not SIM 82)

**C library,
MOBY API for
ASM 824**

The import library is written in C++.
The following functions are supported.

- Read MDS
- Initialize MDS
- Write MDS

Driver software is available for the 3964R protocol.

The programming guide is included as a PDF file on the “Software MOBY” CD.

Ordering data

Table 7-1 Ordering data for MOBY software

	Order No.
Software MOBY	6GT2 080-2AA10

7.2 MOBY Wide Range Power Pack

Description

The MOBY[®] wide range power pack is a compact, primary-pulsed power supply. It is designed for use on single-phase, alternating current networks with two DC outputs (socket connector, circuited in parallel). Its robust physical characteristics include an aluminum housing which gives the finely-tuned system physical strength, protection against electromagnetic interference and optimum heat dissipation. A built-in power limitation circuit protects the primary-pulsed power supply against overload and short circuiting. The standard model has overvoltage protection (SIOV) which protects the connected electronics against excessive voltage.



Figure 7-1 MOBY wide range power pack

Ordering data

Table 7-2 Ordering data for MOBY wide range power pack

	Order No.
MOBY wide range power pack, 100 to 230 V AC/24 V DC/2.2 A, incl. 2 counterplugs for the output voltage	6GT2 494-0AA00
24 V stub line for ASM 824/850/854, SLG 80/82, SIM 80/82; length: 5 m	6GT2 491-1HH50

Technical data

Table 7-3 Technical data of MOBY wide range power pack

Input	
Input voltage	
Nominal value	100 to 230 V AC
Range	90 to 253 V AC
Frequency	50/60 Hz
Input current	0.85 to 0.45 A
Efficiency	≥ 80 % at full load
Power connection	2 m power cable with protection contact plug
Power failure bypass	≥ 10 msec
Undervoltage switch-off	Yes
Overvoltage protection	SIOV

Table 7-3 Technical data of MOBY wide range power pack

Output Output nominal voltage Output nominal current Residual ripple Startup current limitation Continuous short circuit proof	Socket contacts 24 V DC 2.2 A 20 mV _{SS} Up to 160 kHz 50 mV _{SS} Over 160 kHz NTC Yes
Ambient conditions Ambient temperature During operation During transportation and storage Ventilation	-20° C to +40° C (max. of +60° C, see notes on safety) -40° C to +80° C Convection
General specifications Dimensions of power supply incl. mounting plate, (L x W x H) in mm Weight Color	205 x 80 x 60 (without connection plug) Approx. 1000 g Anthracite
Elektromagnetic compatibility Interference emission (EN 50081-1) Interference immunity (EN 50082-2)	Class B in acc. w. EN 55022 EN 61000-4-2
Safety Certifications Electrical safety check Galvanic isolation, primary/secondary Protection class Protection rating	CE, GS EN 60950/VDE 0805 and VDE 106, part 1 4 kV AC I, in acc. w. EN 60950 (VDE 0805) IP65 in acc. w. EN 60529 (only when installed)

Plug connector allocation of 24 V output

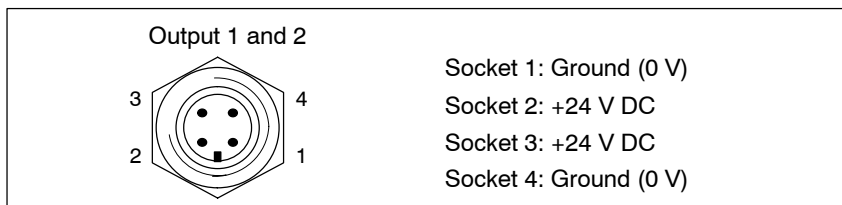

Figure 7-2 Plug connector allocation of 24 V output

Dimensions (in mm)

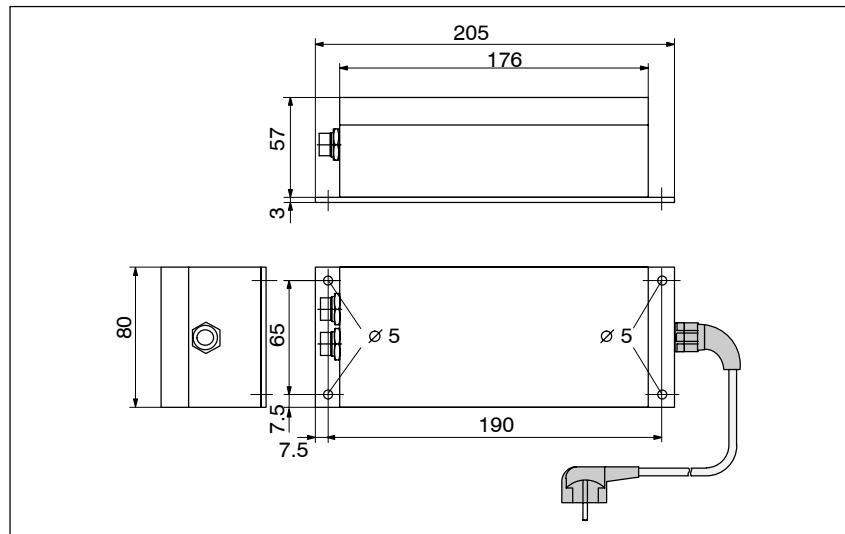

Figure 7-3 Dimensions of the MOBY wide range power pack

Notes on safety



Caution

Do not open the devices or modify them.

Non-adherence will invalidate the CE seal and the manufacturer's warranty. When installing the power pack, it is essential to comply with the applicable DIN/VDE regulations or the regulations of your country.

The application area of the power pack is restricted to "information technological, electrical office machine" covered by standard EN 60950/VDE 0805.

A device may only be commissioned and operated by qualified personnel. For the purposes of the safety notes in this product documentation, qualified personnel are those persons who are authorized to commission, ground and tag devices, systems and current circuits in accordance with safety standards. The device may only be used for the applications described in the catalog and technical description and only in connection with components and devices recommended and approved by Siemens.

Correct operation of the product is dependent on correct storage, setup and mounting as well as careful use and maintenance.

When mounting, make sure that the power outlet socket can be accessed easily. During operation, the housing may heat up up to +40° C. This is no cause for concern. However, remember that the power pack must be covered if the ambient temperature exceeds +40° C to prevent people from touching the hot housing. The power pack must be sufficiently ventilated even when covered.

7.3 MOBY Hand-Held Terminal STG F

Application area

The STG F is a powerful, mobile, hand-held terminal for the MOBY F identification system. It is designed for applications in warehouses, logistics, distribution and service. The service and test device (STG F) is an indispensable aid for commissioning and testing. All MOBY F data memories can be inductively read and written.



Figure 7-4 MOBY STG F hand-held terminal

Layout and function

The STG F mobile, hand-held terminal consists of a basic device (Basis PSION Workabout^{mx}) and a compact, snap-on read/write head. It is equipped with a housing which is protected against splashed water (IP54), an LCD display with 240 x 100 pixels, an alphanumeric keyboard and various interfaces (for EEPROM card, charge battery, RS 232/TTL for MOBY F read head, battery charging interface incl. RS 232 for the PC coupling, and so on). The included MOBY software (memory card) provides the service and test functions for reading, writing, etc. all MOBY F data memories.

- Read data from data memory
- Write data to data memory (only r/w MDS F4xx)
- Read and display ID number of data memory
- Display and edit data in hexadecimal or ASCII format
- Enable/disable password protection

Using the optional C library as a basis, it is very easy to program your own applications (including a customized user interface) for reading/writing the data memories. Also available directly from PSION are various development tools for the PC and a wide selection of accessories. The device opens up new applications in the area of logistics and distribution (e.g., commissioning data can be recorded or edited offline with the hand-held terminal and forwarded later to the PC/computer).

Hardware

The following figure shows the primary hardware interfaces with which you can write your applications.

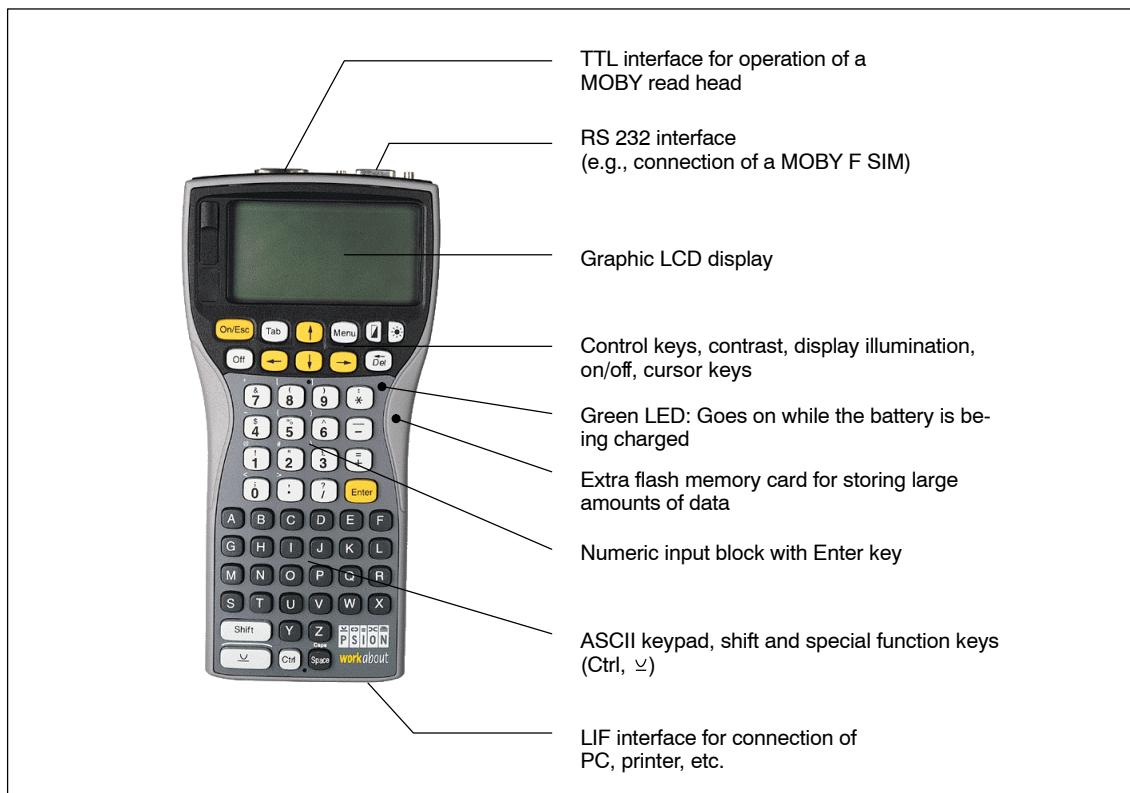

Figure 7-5 Hardware of the STG F

If you are using a different type of PSION Workabout, other interfaces are available. Some examples are listed below.

- Infrared interface
- Numeric keyboard and function keys

Ordering data

Table 7-4 Ordering data of STG F

STG F mobile, hand-held terminal Basic device (PSION Workabout ^{mx}) with MOBY F read/write head, battery, standard software incl. STG functions on EEPROM card, operating instructions, without charging station	6GT2 403-0BA00
Charging station for a mobile hand-held terminal incl. plug-in power pack (230 V AC)	6GT2 303-1DA00
Accessories: MOBY F read/write head, 125 kHz without software and without description	6GT2 403-1BA00
Memory card with STG software and filehandler software for MOBY D/E/F/I/U incl. operator's guide	6GT2 303-1CA00
C library for MOBY D/E/F/I/U for development of customer-specific screen dialogs, without development tools, incl. description	6GT2 381-1AB00
Replacement battery	6GT2 094-0AB00 or 2 AA batteries (NiCd, Ni-MH, alkali)
Other PSION components (e.g., 3link cable, C development interface)	Obtain from local dealer or PSION (See http://www.pSION.com/industrial/ .)

Technical data

Table 7-5 Technical data for STG F hand-held terminal

Hardware	
Processor	NED V30mx 27.68 MHz (80C86 compatible)
RAM	2 MB, approx. 1.8 MB of this can be used as desired
ROM	2 MB for operating system
User program	256 KB (with MOBY service and test program)
Display	Graphic LCD with 240 x 100 pixels, gray scales, backlighting can be enabled.
Keyboard	Alphanumeric keypad with 57 keys
Sound	Piezo signal encoder
Power supply	NiCd battery back with 2 type AA batteries (850 mAh). High-speed charging, automatic switch-off
Operating time	20 hours: read head inactive, display not lighted 4.5 hours: read head active, display not lighted 10 hours: read head inactive, display lighted
Interfaces	LIF interface (Low Insertion Force) for battery charging and communication with PC and printer (3link cable not included) RS 232 and TTL interfaces for connecting a MOBY read head
Security	Lock for battery and program memory

Table 7-5 Technical data for STG F hand-held terminal

Software		
Operating system	EPOC/16 multi-tasking, graphics support, GUI interface, Interpreter similar to MS-DOS	
File management	MS-DOS compatible	
Integrated software	MOBY service and test program, spreadsheet calculation, data base, pocket calculator, communication	
MOBY STG program	Read, write, delete MDS. Read MDS ID. Save and load MDS data. Menu language: German or English. Data entered and displayed in ASCII or HEX.	
Technical data	Complete device (incl. batteries)	Read head
Dimensions	260 x 90 x 35 [mm]	90 x 64 x 35 [mm]
Weight	Approx. 440 g	Approx. 110 g
Temperature	Operation: -20° C to +60° C Storage: -25° C to +80° C (without battery)	
Relative humidity	0% to 90%, no condensation	
Protection rating	IP54 (protected against splashed water)	
Shock resistance	Max. height of fall to concrete: 1 m	
EMC	EN 55022	
Electrostatic; RF; EFT	IEC 801-2; IEC 801-3; IEC 801-4	
RF write/read head		
MOBY F	125 kHz	
Max. read/write distances	MDS type	Distance in mm
	F124	60
	F125	80
	F160	40
	F415	50

Documentation

A

Starting 10.01.2004, the technical documentation of MOBY is only available electronically on the “Software MOBY” CD with the order number 6GT2 080-2AA10.

Technical descriptions

- Description ASM 400/401 (German/English)
- Description ASM 410 (German/English)
- Description ASM 450/FC 44 (German/English/French)
- Description FC 45 (German/English/French)
- Description ASM 470/FC 47 for SIMATIC S7 (German/English)
- Description ASM470/FB 47 for SIMATIC S5 (German/English)
- Description FB 250 for ASM 400/401 (German/English)
- Description 3964 R for Windows 95/NT (German/English)
- Description T3964R for DOS (German/English)
- Description MOBY API (German/English)
- Description C-library MFWAPI for Windows 95/NT 4.0 (German/English)

Operator control guides

- Operator control guide for STG MOBY hand-held terminal (English/German) (also included with STG F)
- Programming instructions for STG MOBY hand-held terminal (English/German)

Error Messages

B

This chapter contains a list of MOBY I, E, F error messages. These messages are divided into two groups.

- B.1 Error numbers 01 hex to 1F hex are described in the first section. These messages are the same for all interfaces which use direct MDS addressing.
- B.2 Some function blocks (e.g., FB 250, FB 240 and FC 47) provide additional messages on the status of the hardware. These special messages are description in the second section.

B.1 General Errors

The following error codes can occur during MOBY F operation. They are transferred in the status byte during telegram communication or indicated on the red LED on the front panel. This LED indicates the last error (for most ASMs) even after it has already been corrected.

For ASM 450, the error codes are also optionally reported via PROFIBUS as device-specific diagnoses.

Table B-1 General errors

Error Code in Hex	LED Indication	Cause/Remedy
00	00	No error, result is okay.
00	01	The ASM is not yet initialized to the SIMATIC. → Send new start/RESET to ASM.
03	03	Error in connection to the SLG → Supply voltage of ASM < 20 V or not connected → 24 V voltage has voltage drops. → use on the ASM has blown. Check wiring. → Cable between ASM and SLG is wired incorrectly or cable break. → Hardware defect: ASM or SLG → Other SLG is active in the vicinity. → Field interference
05	05	Unknown command code → The MDS reports address error. Check telegram. → Read/write area of MDS requires password. → Encryption or password for this area is wrong. → Data comparison error → Write-access not permitted (write-protected area) → Read-access not permitted (read-protected area) → FFT command with presence check → Mode doesn't fit command (e.g., MOBY I with FFT command) → Switch setting 4 (INIT) with read/write command (ASM 410)
06	06	Field interference on SLG SLG is receiving interference from its environment. → External interference field → Distance between two SLGs is too small and does not meet configuration guidelines. → Connection cable to SLG is malfunctioning, is too long or does not meet specifications.
07	07	Too many sending errors MDS was unable to correctly receive the command or the write data from the SLG even after several attempts. → The MDS is positioned exactly on the boundary area of the transmission window. → Data transmission to MDS is being affected by external interference. → Antenna is mounted too close to metal.

Table B-1 General errors

Error Code in Hex	LED Indication	Cause/Remedy
08	08	<p>CRC sending error</p> <ul style="list-style-type: none"> – Monitor receiving circuit detected an error during sending. <p>→ Same cause as error 06</p> <ul style="list-style-type: none"> – MDS reports CRC errors very frequently. <p>→ MDS is positioned in the boundary area of SLG. → MDS and/or SLG have hardware defect.</p>
09	09	<p>Wrong MDS type for special commands</p> <p>→ Set data carrier type with special command (type 3)</p>
0C	12	<p>EEPROM error Memory of the MDS cannot be written.</p> <p>→ MDS was write-accessed too often. → MDS memory defective.</p>
0D	13	<p>Address error (address area exceeded)</p> <p>→ Specified address does not exist on MDS. → Check and correct command for telegram layout. → Status byte of command is not 00.</p>
0E	14	<p>ECC error Data could not be read from MDS.</p> <p>→ MDS data have been lost (MDS defective) → MDS was not initialized with ECC driver. → Initialize MDS. → MDS has reached the end of its life, and the data have been lost. → Replace MDS. → While being write-accessed, MDS was moved out of the field or field interference occurred. → MDS is not positioned correctly. → Remove interference.</p>
0F	01	<p>Startup message of ASM. The ASM was off and still had not received a RESET command.</p> <p>→ Perform init_run → The same physical ASM channel is used in two (or more) UDT 10 structures. Check ASM_address and ASM_channel in <u>all</u> UDT 10 structures.</p>
0F	15	<p>MOBY F driver error</p> <p>→ Internal error. → FFT command with MDS F1xx in field. → Telegram from reader cannot be interpreted.</p>
19	25	<p>Previous command active A new command was sent to the ASM although the last command is still active.</p> <p>→ An active command can only be terminated by a RESET command. → The new command is concluded with error 19 hex. The old command is executed by the ASM and reported as finished after its execution.</p>
1A	26	<p>No data carrier selected or wrong MDS type</p> <p>→ MDS type was not set correctly (special commands).</p>

Table B-1 General errors

Error Code in Hex	LED Indication	Cause/Remedy
1B	27	Telegram with checksum error received → CRC check for data telegram not okay. → Data distortion. → Interface defective. → Send command again.
1D	29	Insufficient RAM on the ASM → Chained MOBY command must be divided into several commands.
1E	30	Error while processing the function block → Data in FB DB are incorrect. → Perform RESET command. → Parameterization error: The “Typ” parameter is not 1 to 6. → Parameterization error: The command in ZUWDB has an error (e.g., length = 0). → ASM hardware defective: The channel module received incorrect data during RESET.
1F	31	Command aborted due to RESET command

B.2 ASM-Related Errors

B.2.1 ASM 400 with FB 250

The messages shown in table B-2 are indicated in data word 5 of FBDB.

Table B-2 Error messages of FB 250

Error Message	Cause/Remedy
Bit 1 = "1": Synchronization error	<ul style="list-style-type: none"> • FB 250 has received the result for a command which is not located in ZUWDB (i.e., not at this location). The pointer (ZUW) to ZUWDB may have been changed while a command was active. • EMC effects have caused the ASM to execute another command than programmed by the user. <p>→ Check the entire SIMATIC system. Check the grounding concept.</p>
Bit 2 = "1": FB 250 is synchronized (SYNCH)	<p>General communication capability with a channel module of the ASM 400 module. This bit is set after a positive check of the FB parameterization.</p> <p>This takes place during the 1st RESET immediately after bootstrap loading of the programs and data blocks. When a RESET command does not function, the bit is not set or reset.</p> <p>ASM 400 module cannot be addressed by the FB.</p> <ul style="list-style-type: none"> • Wrong address set on the ASM 400 • ASM 400 is defective. <p>→ A RESET must always be performed after the sync bit is reset.</p>
Bit 4 = "1": Parameterization error	<ul style="list-style-type: none"> • The "ADR" parameter does not contain the correct values. • The "KAN" parameter is specified incorrectly. Permitted values are 1 or 2. • The "TYP" parameter was specified incorrectly. Permitted values are 0, 1, 3, 5, and 6. • The "ANW" parameter is not "0" or "1". • The command is not permitted in ZUWDB.
Bit 5 = "1": ASM error	<ul style="list-style-type: none"> • The exact ASM error is located in bits 8 to 15 of ANZ. <p><u>If bits 8 to 15 = 0:</u></p> <ul style="list-style-type: none"> • The FB did not receive an acknowledgment from the ASM in time after command transfer. • FB 250 was not called by the user within 4 seconds after command start (no cycle FB call). • The user changed data in the FBDB (DW 0 to DW 24) - particularly DW 0/1.

Table B-2 Error messages of FB 250

Error Message	Cause/Remedy
<p>Bit 6 = "1": Time error</p>	<p>Loop counter monitor in FB 250 has been triggered.</p> <ul style="list-style-type: none"> • The command data could not be or could not be completely transferred to the ASM 400. • The ASM 400 cannot be addressed by the FB. The "ADR" parameter may not correspond to switch setting S3 on the ASM 400. • Length = 0 was transferred with a write command. • The "AG" parameter is set incorrectly. • The user has changed data in FBDB (particularly DW 0/1). <p>→ Check ASM 400 hardware, addressing parameterization and user program.</p>
<p>Bit 7 = "1": Repetition error</p>	<p>The command to the ASM 400 was repeated.</p> <ul style="list-style-type: none"> • Error in BEST = 0 The command was not concluded correctly after command repetition (not an error). • Error in BEST = 1 Communication malfunction between ASM and FB 250. Despite command repetition, the command still could not be executed correctly. <p>When the repetition bit is set sporadically, all hardware must be checked. Special attention should be paid to the grounding concept.</p>
<p>Bits 8 to 12</p>	<p>Error message as shown in table B-1</p>
<p>Bit 13 = "1"</p>	<p>ECC offset was performed.</p>
<p>Bit 14 = "1"</p>	<p>Dialog battery has dropped below threshold value.</p>
<p>Bit 15 = "1"</p>	<p>RAM battery has dropped below threshold value.</p>

B.2.2 ASM 470 with FB 47/FC 47

The indication word for FC 47 is DBB 6/7.

The indication word for FB 47 is DW 3.

- MOBY errors are indicated in DBB 6 or DL 3. Cf. table B-1.
- Internal errors of the function block are indicated in DBB 7 or DR 3. Cf. table B-3. The red LED does not flash for these error messages from FB 47/FC 47. The contents of the byte are specified in hexadecimal format (i.e., HEX) and as fixed point numbers (i.e., DEC).

Table B-3 Error messages of FB 47/FC 47

ANZ (Right- Hand Byte)	Description
02 HEX/ 02 DEC	Illegal command code or command parameter was entered. <ul style="list-style-type: none"> • Parameterize data words in BEDB correctly in accordance with the command description.
06 HEX/ 06 DEC	<ul style="list-style-type: none"> • The command code and the received acknowledgment code are not identical. • Internal processing error • BEDB is being overwritten by other program segments.
07 HEX/ 07 DEC	Synchronization error during execution of FB 47/FC 47 <ul style="list-style-type: none"> • Internal processing error • BEDB is being overwritten by other program segments.
08 HEX/ 08 DEC	The parameterized user data length of the read/write command and the user data length received in the acknowledgment are not identical. <ul style="list-style-type: none"> • ASM 470 not parameterized correctly • BEDB is being overwritten by other program segments.
09 HEX/ 09 DEC	The received or written user data are too long. <ul style="list-style-type: none"> • ASM 470 not parameterized correctly • Read command: The length specified for the data to be read is too long. Maximum of 12 bytes is permitted.
10 HEX/ 10 DEC	Read or written user data length too short. User data length is 0 bytes. <ul style="list-style-type: none"> • Internal processing error • BEDB is being overwritten by other program segments.
17 HEX/ 17 DEC	The formal operands of FB 47/FC 47 were parameterized incorrectly. <ul style="list-style-type: none"> • Parameterize FB 47/FC 47 correctly. • Then start RESET command.

Table B-3 Error messages of FB 47/FC 47

ANZ (Right- Hand Byte)	Description
19 HEX/ 19 DEC	FB 47/FC 47 reports that only a RESET command is permitted as the next command. <ul style="list-style-type: none"> • No RESET was performed after a startup message of the ASM 470. • No RESET was performed after an error message after which a RESET must be the next command. • Start RESET command.
20 HEX/ 20 DEC	Synchronization error between ASM 470 and FB 47/FC 47 <ul style="list-style-type: none"> • The handshake of the command and acknowledgment telegrams got out of step. There may be a contact problem or the supply voltage may be unstable. • BEDB is being overwritten by other program segments. • Start RESET command.
21 HEX/ 21 DEC	ASM 470 has performed a startup. <ul style="list-style-type: none"> • There may be a problem with the plug-in contact of the ASM 470 in the S7-300. • Supply voltage of the ASM 470 is unstable. • Interference pulse • DEDB is being overwritten by other program segments. • Start RESET command.
1 BH/ 27D ¹	<ul style="list-style-type: none"> • The data field (i.e., number of user data bytes) between DAT-Z and the end of DATDB is less than the length given in the write command (DR 4 in BEDB). Exception: DATDB consists of 256 data words (DW 0 to DW 255). • DAT-Z must be adjusted to the user data length. Make DAT-Z smaller. • Reduce length of read/write data. • Start RESET command.

1 Can only occur with FB 47

B.2.3 ASM 450 with FB 240

The error indications (ANZ) of FB 240 are located in data word DW 2 of the BEDB.

- The MOBY errors listed in table B-1 are located in the left-hand byte of the data word (DL 2).
- Internal FB errors are located in the right-hand byte of the data word (DR 2). The red LED does not flash for these FB 240 error messages. The contents of the byte are specified in binary format, in hexadecimal format (H) and as fixed point numbers (D).

Table B-4 Error messages of FB 240

ANZ (Right- Hand Byte)	Description
0000010 (02H/02D)	Illegal command code or command parameter was entered. <ul style="list-style-type: none"> • Parameterize data words in BEDB correctly as specified in the command description.
00000110 (06H/06D)	The command code and the received acknowledgment code are not identical. <ul style="list-style-type: none"> • Input and output area of the ASM 450 is too small. • Parameterize master module correctly.
00000111 (07H/07D)	The received acknowledgment is too long. <ul style="list-style-type: none"> • Input and output area of the ASM 450 is too small (i.e., less than 32 bytes). • Read command: The length of the data to be read is too long. • Parameterize master module correctly.
00001000 (08H/08D)	The parameterized length of the user data of the read/write command and the user data length received in the acknowledgment are not identical. <ul style="list-style-type: none"> • Input and output area of the ASM 450 is too small. • Parameterize master module correctly.
00001001 (09H/09D)	The length of the received user data is too long. <ul style="list-style-type: none"> • Input and output area of the ASM 450 is too small (i.e., less than 32 bytes). • Read command: The length of the data to be read is too long. • Parameterize master module correctly.
00010001 (11H/17D)	The formal operands of FB 240 were parameterized incorrectly or the parameterization in the EPROM of IM 308-B is wrong. <ul style="list-style-type: none"> • Parameterize FB 240 correctly. • Parameterize master module correctly. Check the “ADR” parameter in particular. • Then start RESET command.

Table B-4 Error messages of FB 240

ANZ (Right- Hand Byte)	Description
00010011 (13H/19D)	FB 240 reports that only a RESET is permitted as the next command. <ul style="list-style-type: none"> • No RESET was performed after a startup message of the ASM 450. • No RESET was performed after an error message which requires a RESET as the next command. • Start RESET command.
00010100 (14H/20D)	Synchronization error between ASM 450 and FB 240 <ul style="list-style-type: none"> • The handshake of the command and acknowledgment telegrams got out of step. There may be a contact problem or the supply voltage may be unstable. • Start RESET command.
00010101 (15H/21D)	The ASM 450 has performed a startup or a PROFIBUS DP bus error has occurred. <ul style="list-style-type: none"> • Possible problem with the ASM 450's plug-in contacts in the module rack • Supply voltage of the ASM 450 is unstable. • Interference pulse on the reset input of base connector X1 • PROFIBUS DP error occurred (e.g., bus connection interrupted) • Start RESET command.

ASCII Table

C

dec.	+0	+1	+2	+3	+4	+5	+6	+7	+8	+9	+10	+11	+12	+13	+14	+15
hex.	+00	+01	+02	+03	+04	+05	+06	+07	+08	+09	+0A	+0B	+0C	+0D	+0E	+0F
0	0x00	...	☒	×	☐	☉	☪	-	.	→		√	✓	→		
16	0x10	→	☐	☐	☐	☐	☐	☐	↑	→	→	→	▲	←	◆	
32	0x20		!	"	£	¤	¥	'	()	*	+	,	-	.	/
48	0x30	0	1	2	3	4	5	6	7	8	9	:	<	=	>	?
64	0x40	@	A	B	C	D	E	F	G	H	I	J	K	L	M	N
80	0x50	P	Q	R	S	T	U	V	X	Y	Z	[\]	^	_
96	0x60	`	a	b	c	d	e	f	h	i	j	k	l	m	n	o
112	0x70	p	q	r	s	t	u	v	x	y	z	{		}	~	
128	0x80															
144	0x90			¡	¢	£	¤	¥	¦	§	¨	©	ª	«	¬	­
160	0xA0	¯	°	±	²	³	´	µ	¶	·	¸	¹	º	»	¼	½
176	0xB0	¾	¿													
192	0xC0															
208	0xD0															
224	0xE0															
240	0xF0															

Index

Numbers

3RX9 802-0AA0, 6-25
3SX6 284, 5-21, 6-55
6ES5 491-0LB11, 6-11
6ES5 700-8MA11, 6-16
6ES5 700-8MA22, 6-16
6ES7 141-1BF11-0XB0, 6-46
6ES7 142-1BD21-0XB0, 6-46
6ES7 194-1AA01-0XA0, 6-25
6ES7 194-1FC00-0XA0, 6-25
6ES7 198-8FA01-8AA0, 6-48
6ES7 390-5AA00-0AA0, 6-36, 6-37
6ES7 390-5BA00-0AA0, 6-36, 6-37
6ES7 392-1AJ00-0AA0, 6-37, 6-43
6ES7 972-0BA11-0XA0, 6-55
6GT2 002-0AA00, 6-5
6GT2 002-0AB00, 6-5
6GT2 002-0BA00, 6-16
6GT2 002-0EB00, 6-25
6GT2 002-0EB20, 6-25
6GT2 002-0FA10, 6-37
6GT2 002-0GA10, 6-37
6GT2 002-0HA00, 6-47
6GT2 080-2AA10, 6-5, 6-25, 6-37, 6-47, 7-4
6GT2 090-0BB00, 6-5, 6-8
6GT2 090-0BB10, 6-5
6GT2 090-0BC00, 6-25, 6-29, 6-47
6GT2 091-0E..., 6-43
6GT2 094-0AB00, 7-11
6GT2 303-1CA00, 7-11
6GT2 303-1DA00, 7-11
6GT2 381-1AB00, 7-11
6GT2 390-0BA00, 5-11, 5-15, 6-56
6GT2 390-1AB00, 3-52, 6-55
6GT2 391-0B..., 3-56, 6-55
6GT2 391-0BH50, 3-58
6GT2 391-1AH50, 3-56, 3-58, 6-55, 6-56
6GT2 391-1BN10, 3-57, 3-58, 6-55
6GT2 391-1BN25, 3-57, 3-58, 6-55
6GT2 400-1CE00, 4-4
6GT2 400-1CF00, 4-7
6GT2 400-1GA00, 4-10
6GT2 400-4BF00, 4-13
6GT2 401-0AF00, 5-3
6GT2 401-2AA00, 5-26
6GT2 401-2BB00, 5-21, 6-55
6GT2 401-2CB00, 5-15
6GT2 402-2BB00, 6-55
6GT2 402-2CE00, 6-55
6GT2 402-2EA00, 6-55
6GT2 403-0BA00, 7-11
6GT2 403-1BA00, 7-11
6GT2 405-0AF00, 6-75
6GT2 405-2CB00, 6-82
6GT2 490-1AA00, 3-51, 5-4, 6-77
6GT2 491-0A..., 3-53
6GT2 491-0AH50, 3-58
6GT2 491-0AN20, 3-58
6GT2 491-0D..., 3-53, 6-23
6GT2 491-0DH50, 3-58
6GT2 491-0DN20, 3-58
6GT2 491-0E..., 3-54, 6-36
6GT2 491-0EH50, 3-58, 6-37
6GT2 491-0EN20, 3-58, 6-37
6GT2 491-0EN50, 3-58, 6-37
6GT2 491-1C..., 3-54, 6-29
6GT2 491-1CH20, 3-58, 6-25, 6-47
6GT2 491-1CH50, 3-58, 6-25, 6-47
6GT2 491-1CN20, 3-58, 6-25, 6-47
6GT2 491-1DH50, 3-55, 3-58
6GT2 491-1HH50, 3-57, 3-58, 6-55, 6-56, 7-5
6GT2 494-0AA00, 5-11, 6-54, 6-55, 6-56, 7-5
6GT2 499-1BC00, 5-11
6GT2 690-0AB00, 5-9
6GT2 691-0BH50, 3-55, 3-58
6GT2 691-0BN20, 3-55, 3-58

A

Adapter floor plate for top hat rail mounting,
5-14, 5-20, 6-60, 6-89

Amount of data, Transmitted based on MDS speed, 3-14

ASM 400

- Address settings, 6-9
- Function block FB 250, 6-7
- Layout and function, 6-4
- Ordering data, 6-5
- Plug connectors and their assignment, 6-8
- Settings on the channel module, 6-10
- SIMATIC adapter capsule, 6-11
- SIMATIC S5 Configuration, 6-11
- Switches and plug-in jumpers, 6-9
- Technical data, 6-6

ASM 410

- Configuration in ET 100U/ET 200U, 6-19
- Layout and function, 6-15
- Ordering data, 6-16
- Setting the operating mode, 6-21
- Slots in PLC, 6-18
- Technical data, 6-17
- Wiring of one or two SLGs, 6-23

ASM 450

- Dimensions, 6-31
- Layout and function, 6-24
- Ordering data, 6-25
- Pin allocation, 6-32
- PROFIBUS address and terminating resistance, 6-34
- PROFIBUS configuration, 6-28
- SLG connection technique, 6-28
- Technical data, 6-26

ASM 452

- Dimensions, 6-31
- Layout and function, 6-24
- Ordering data, 6-25
- Pin allocation, 6-32
- PROFIBUS address and terminating resistance, 6-34
- PROFIBUS configuration, 6-28
- SLG connection technique, 6-28
- Technical data, 6-26

ASM 470

- Installation of the software, 6-44
- Layout and function, 6-35
- Ordering data, 6-37
- Technical data, 6-38
- Wiring to the SLG, 6-43

ASM 473

- Configuration, 6-49
- Dimensions, 6-53
- Hardware configuration, 6-51
- Layout and function, 6-46
- Ordering data, 6-47
- Pin assignment, 6-52
- SLG connection, 6-51
- Technical data, 6-47

ASM 475

- Layout and function, 6-36
- Installation of the software, 6-44
- Ordering data, 6-37
- Technical data, 6-38
- Wiring to the SLG, 6-43

ASM 824

- Adapter floor plate for top hat rail mounting, 6-60
- Dimensions, 6-60
- Layout and function, 6-54
- Ordering data, 6-55
- Pin allocations and switches, 6-58
- Technical data, 6-57

ASM 850

- Adapter floor plate for top hat rail mounting, 6-60
- Dimensions, 6-60
- Layout and function, 6-54
- Ordering data, 6-55
- Pin allocations and switches, 6-58
- Technical data, 6-57

ASM 854

- Adapter floor plate for top hat rail mounting, 6-60
- Dimensions, 6-60
- Layout and function, 6-55
- Ordering data, 6-55
- Pin allocations and switches, 6-58
- Technical data, 6-57

C

C library

- MFWAPI, 7-4
- MOBY API, 7-4

Cable configuration, 3-48

- Cables, Shielding, 3-42
- Chemical resistance of the mobile data memories, 3-27
- Communication
 - Between ASM and user program, 3-8
 - Between ASM, SLG/SLA and MDS F4xx, 3-7
- Concept of shielding, 3-46
- Connection cables, 3-53

- D**
- Data structure of the MOBY F data memory
 - MDS F1xx, 6-66
 - MDS F4xx, 6-62
- Documentation
 - Operator control guides, A-1
 - Technical descriptions, A-1

- E**
- EMC basic rules, 3-44
- EMC guidelines, 3-29
 - Avoiding interference sources, 3-39
 - FFT command, 3-34
- Equipotential bonding, 3-40

- F**
- FFT command, 3-34
- Field data, 3-11, 6-67

- L**
- LEDs for MOBY, 6-52
- LEDs for PROFIBUS DP, 6-52

- M**
- MDS F124
 - Dimensions, 4-5
 - Field data, 4-5
 - Metal-free space, 4-6
 - Ordering data, 4-4
 - Technical data, 4-4
- MDS F125
 - Dimensions, 4-8
 - Field data, 4-8
 - Metal-free space, 4-9
 - Ordering data, 4-7
 - Technical data, 4-7
- MDS F160
 - Dimension, 4-11
 - Field data, 4-11
 - Metal-free space, 4-12
 - Ordering data, 4-10
 - Technical data, 4-10
- MDS F415
 - Dimensions, 4-15
 - Field data, 4-14
 - Memory organization, 4-14
 - Metal-free space, 4-15
 - Ordering data, 4-13
 - Technical data, 4-13
- Metal-free space, 3-16
 - Flush mounting of antenna in metal, 3-17
 - Flush mounting of the SLG 82 in metal, 3-18
 - Mounting of antenna on metal, 3-17
- MFWAPI, 7-4
- MOBY API, 7-4
- MOBY Hand-Held Terminal STG F
 - Hardware, 7-10
 - Layout and function, 7-8
 - Ordering data, 7-11
 - System prerequisites, 7-9
 - Technical data, 7-11
- MOBY wide range power pack
 - Dimensions, 7-7
 - Ordering data, 7-5
 - Plug connector allocation of 24 V output, 7-6
 - Technical data, 7-5
- Mounting clamp, 5-25

- P**
- Plug connector allocations, 3-49

S

SIM 80 ANT F5

- Definition of distance D, 6-80
- Dimensions, 6-81
- Field data, 6-77
- Layout and function, 6-61
- Metal-free space, 6-79
- Ordering data, 6-75
- Technical data, 6-76
- Transmission window, 6-79

SIM 82

- Adapter floor plate for top hat rail mounting, 6-89
- Definition of distance D, 6-86
- Dimensions, 6-88
- Field data, 6-84
- Layout and function, 6-61
- Metal-free space, 6-85
- Ordering data, 6-82
- Pin allocations and switches, 6-86
- Technical data, 6-82
- Transmission window, 6-84

SLA 81

- Definition of distance D, 5-24
- Dimensions, 5-24
- Field data, 5-22
- Metal-free space, 5-23
- Mounting clamp, 5-25
- Ordering data, 5-21
- Technical data, 5-21
- Transmission window, 5-23

SLA 82

- Definition of the distance D, 5-29
- Dimensions, 5-29
- Field data, 5-27
- Metal-free space, 5-28
- Ordering data, 5-26
- Technical data, 5-26
- Transmission window, 5-28

SLG 80 ANT F5

- Adapter floor plate for top hat rail mounting, 5-20
- Definition of distance D, 5-7
- Dimensions, 5-8
- Field data, 5-5
- Metal-free space, 5-6
- Ordering data, 5-3
- Technical data, 5-3
- Transmission window, 5-6

SLG 82

- Definition of distance D, 5-18
- Dimensions, 5-19
- Field data, 5-17
- Metal-free space, 5-17
- Ordering data, 5-15
- Pin allocations and switches, 5-18
- Technical data, 5-15
- Transmission window, 5-17

SLG 82 basic device

- Adapter floor plate for top hat rail mounting, 5-14
- Dimensions, 5-14
- Ordering data, 5-11
- Pin allocations and switches, 5-13
- Technical data, 5-12

Software MOBY, 7-2

- Ordering data, 7-4

Spacer kit for MOBY F ANT F5, 5-9

Stecker, Bestelldaten, 3-51, 3-52

T

Transmission window, 3-3

- Effects of metal, 3-19
- Reduction of metallic effects, 3-24

Transmit period of the MDS, 3-6