

SIEMENS

SIMATIC

Distributed I/O ET 200eco PN



Operating Instructions

Preface	
Product overview	1
Installing	2
Wiring	3
Configuring	4
Commissioning	5
Maintenance	6
Interrupt, error, and system messages	7
General technical data	8
I/O device digital inputs/digital outputs	9
I/O device analog input/analog output	10
IO-Link Master	11
Terminal block and voltage distributor	12
Signal names	A
Article numbers	B
Dimensional drawings	C
Connection examples	D
I/O address space	E
Response times for analog input device and output device	F
Fail-safe shutdown of ET 200eco PN standard modules	G
Open Source Software	H

Legal information

Warning notice system

This manual contains notices you have to observe in order to ensure your personal safety, as well as to prevent damage to property. The notices referring to your personal safety are highlighted in the manual by a safety alert symbol, notices referring only to property damage have no safety alert symbol. These notices shown below are graded according to the degree of danger.

 DANGER
indicates that death or severe personal injury will result if proper precautions are not taken.
 WARNING
indicates that death or severe personal injury may result if proper precautions are not taken.
 CAUTION
indicates that minor personal injury can result if proper precautions are not taken.
NOTICE
indicates that property damage can result if proper precautions are not taken.

If more than one degree of danger is present, the warning notice representing the highest degree of danger will be used. A notice warning of injury to persons with a safety alert symbol may also include a warning relating to property damage.

Qualified Personnel

The product/system described in this documentation may be operated only by **personnel qualified** for the specific task in accordance with the relevant documentation, in particular its warning notices and safety instructions. Qualified personnel are those who, based on their training and experience, are capable of identifying risks and avoiding potential hazards when working with these products/systems.

Proper use of Siemens products

Note the following:

 WARNING
Siemens products may only be used for the applications described in the catalog and in the relevant technical documentation. If products and components from other manufacturers are used, these must be recommended or approved by Siemens. Proper transport, storage, installation, assembly, commissioning, operation and maintenance are required to ensure that the products operate safely and without any problems. The permissible ambient conditions must be complied with. The information in the relevant documentation must be observed.

Trademarks

All names identified by ® are registered trademarks of Siemens AG. The remaining trademarks in this publication may be trademarks whose use by third parties for their own purposes could violate the rights of the owner.

Disclaimer of Liability

We have reviewed the contents of this publication to ensure consistency with the hardware and software described. Since variance cannot be precluded entirely, we cannot guarantee full consistency. However, the information in this publication is reviewed regularly and any necessary corrections are included in subsequent editions.

Preface

Purpose of the manual

The information in this manual enables you to operate the ET 200eco PN distributed I/O device on PROFINET IO as an IO Device.

Basic knowledge required

This manual presumes a general knowledge in the field of automation engineering.

The manual describes the components based on the data valid at the time of its release. SIEMENS reserves the right of including a product information for each new component, and for each component of a later version.

Scope of this manual

This manual applies to the ET 200eco PN distributed I/O device.

Changes compared to the previous version

Compared with the previous version, this manual includes the following changes/additions:

- Description of the IO-Link master 4 IO-L 4×M12
- Update of the Standards and Approvals chapter

Standards and certifications

You can find information of which standards and approvals are met by the ET 200eco PN I/O system in the section Standards and certifications (Page 99).

Scope of information

In addition to this manual, you need:

- The manual for the IO Controller you are using
- The PROFINET System Description (<https://support.industry.siemens.com/cs/ww/en/view/19292127>) system manual,
- The From PROFIBUS DP to PROFINET IO (<https://support.industry.siemens.com/cs/ww/en/view/19289930>) programming manual.
- The IO-Link System (<https://support.industry.siemens.com/cs/ww/en/view/65949252>) function manual.

Guide

This manual describes the hardware of the ET 200eco PN distributed I/O device. It consists of instructive sections and reference sections (specifications).

Topics covered in this manual include

- Installing and wiring the ET 200eco PN distributed I/O device
- Commissioning and diagnostics of the ET 200eco PN distributed I/O device
- Components of the ET 200eco PN distributed I/O device
- Article numbers
- Important terms are explained in the glossary.
- The index helps you to quickly find all texts relevant to your keyword.

Recycling and disposal

ET 200eco PN can be recycled owing to its low pollutant content.

For ecologically compatible recycling and disposal of your old device, contact a certificated disposal service for electronic scrap.

Training Centers

Siemens offers corresponding courses to get you started with your ET 200eco PN distributed I/O device and the SIMATIC S7 automation system. Please contact your local training center.

Additional information can be found on the Internet (http://www.sitrain.com/index_en.html).

Technical Support

Expert advice on technical questions with a wide range of demand-optimized services for all our products and systems.

You can find Technical Support at the following address on the Internet (<https://support.industry.siemens.com/cs/ww/en/sc/2090>).

Additional support

If you have any further questions about the use of products described in this manual, and do not find the right answers there, contact your local Siemens representative:

You can find your representative on the Internet (<http://www.automation.siemens.com/partner/guiwelcome.asp?lang=en>).

A guide to the technical documentation for the various SIMATIC products and systems is available on the Internet (<https://support.industry.siemens.com>).

The online catalog and ordering systems are available on the Internet (<http://mall.industry.siemens.com>).

Security information

Siemens provides products and solutions with industrial security functions that support the secure operation of plants, systems, machines and networks.

In order to protect plants, systems, machines and networks against cyber threats, it is necessary to implement – and continuously maintain – a holistic, state-of-the-art industrial security concept. Siemens' products and solutions only form one element of such a concept.

Customer is responsible to prevent unauthorized access to its plants, systems, machines and networks. Systems, machines and components should only be connected to the enterprise network or the internet if and to the extent necessary and with appropriate security measures (e.g. use of firewalls and network segmentation) in place.

Additionally, Siemens' guidance on appropriate security measures should be taken into account. For more information about industrial security, please visit (<http://www.siemens.com/industrialsecurity>).

Siemens' products and solutions undergo continuous development to make them more secure. Siemens strongly recommends to apply product updates as soon as available and to always use the latest product versions. Use of product versions that are no longer supported, and failure to apply latest updates may increase customer's exposure to cyber threats.

To stay informed about product updates, subscribe to the Siemens Industrial Security RSS Feed under (<http://www.siemens.com/industrialsecurity>).

Table of contents

	Preface	3
1	Product overview	10
1.1	Distributed I/O device – Overview	10
1.2	ET 200eco PN Distributed I/O Device	12
2	Installing	20
2.1	Installation without mounting rail	20
2.2	Installation with mounting rail	24
2.3	Mounting position, mounting dimensions	24
2.4	Installing the terminal block	25
2.5	Replacing labels	27
2.6	Removing ET 200eco PN	28
3	Wiring	29
3.1	General rules and regulations for operating an ET 200eco PN	29
3.2	Operating ET 200eco PN on grounded mains	30
3.3	Electrical configuration of ET 200eco PN	33
3.4	Technical specifications of the lines	34
3.5	Wiring the ET 200eco PN	35
3.5.1	Wiring the ET 200eco PN to functional earth (FE)	35
3.5.2	Wiring I/O devices	37
3.6	Pin assignment of connectors	39
3.6.1	Pin assignment of the PROFINET connector	39
3.6.2	Pin assignment for feeding and looping the voltage	40
3.6.3	Pin assignment of digital inputs	41
3.6.4	Pin assignment of digital outputs	44
3.6.5	Pin assignment for parameterizable digital input/digital output	48
3.6.6	Pin assignment for IO-Link Masters	49
3.6.7	Pin assignment for analog inputs	52
3.6.8	Pin assignment M12 compensation connector for thermocouples	57
3.6.9	Pin assignment for analog output	58
3.7	Wiring the terminal block	59
3.8	Wiring the voltage distributor	63
3.9	Looping PROFINET and the supply voltage	66

4	Configuring	67
4.1	Configuring ET 200eco PN	67
4.2	Configuring an IO-Link master	68
4.2.1	Configuring the IO-Link Master 6ES7148-6JA00-0AB0	68
4.2.2	Configuring the IO-Link Master 6ES7148-6JD00-0AB0	70
4.3	Device names for ET 200eco PN	71
4.4	Ports of ET 200eco PN	72
4.5	Isochronous real-time communication	73
4.6	Prioritized startup	74
4.7	Device replacement without programming device	74
4.8	Media redundancy	75
4.9	Reset to factory settings (PROFINET)	75
4.10	SNMP	76
5	Commissioning	77
5.1	Commissioning ET 200eco PN	77
6	Maintenance	79
6.1	Replacing the fuse	79
6.2	Online firmware update by means of STEP 7 Manager	80
6.3	Acyclic data exchange with the IO-Link library	81
6.4	Exchange object	82
7	Interrupt, error, and system messages	83
7.1	Interrupts of ET 200eco PN	83
7.2	Maintenance interrupts	84
7.3	Diagnostics by means of LED display	85
7.3.1	Diagnostics using the LED display on the I/O devices	85
7.3.2	Diagnostics using LED display on the IO-Link masters	88
7.3.3	Diagnostics using the LED display at the voltage distributor	91
7.4	Diagnostics messages of the I/O devices	92
7.5	Diagnostics with STEP 7	92
7.5.1	Reading diagnostics data	92
7.5.2	Channel diagnostics	93
7.5.3	Error classes for I/O devices	94
7.5.4	STOP of the IO Controller and recovery of the IO Device	98

8	General technical data	99
8.1	Standards and certifications.....	99
8.2	EMC compatibility, shipping and storage conditions	102
8.3	Mechanical and climatic environmental conditions.....	104
8.4	Specification of dielectric tests, protection class, degree of protection, and rated voltage of ET 200eco PN	107
9	I/O device digital inputs/digital outputs	108
9.1	I/O device digital inputs	108
9.1.1	I/O device 8 DI DC 24 V 4xM12.....	108
9.1.2	I/O device 8 DI DC 24 V 8xM12.....	112
9.1.3	I/O device 16 DI DC 24 V 8xM12.....	116
9.1.4	Parameter overview digital inputs	120
9.2	I/O device digital outputs.....	121
9.2.1	I/O device 8 DO DC 24 V/1.3A 4xM12.....	121
9.2.2	I/O device 8 DO DC 24 V/0.5A 4xM12.....	126
9.2.3	I/O device 8 DO DC 24 V/1.3A 8xM12.....	131
9.2.4	I/O device 8 DO DC 24V/2.0A 8xM12.....	135
9.2.5	I/O device 16 DO DC 24 V/1.3A 8xM12	141
9.2.6	Parameter overview digital outputs.....	146
9.3	I/O device digital inputs/digital outputs	148
9.3.1	I/O device 8 DIO DC 24V/1.3A 8xM12.....	148
9.3.2	Parameter overview digital inputs/digital outputs.....	153
10	I/O device analog input/analog output	154
10.1	I/O device analog input	154
10.1.1	I/O device 8 AI 4 U/I + 4 RTD/TC 8xM12.....	154
10.1.2	8 AI RTD/TC 8xM12 I/O device	163
10.1.3	Parameter overview analog input	170
10.1.4	Parameter description analog input	176
10.1.5	Analog value representation for measuring ranges with SIMATIC S7	182
10.1.6	Measuring ranges of the analog input device in S7 format	182
10.1.7	Dynamic reference temperature with module 8 AI RTD/TC 8xM12	190
10.2	I/O device analog output	195
10.2.1	I/O device 4 AO U/I 4xM12	195
10.2.2	Parameter overview analog output	201
10.2.3	Parameter description analog output.....	202
10.2.4	Output ranges of analog output device.....	204
10.3	Influence of the range of values.....	205

11	IO-Link Master	207
11.1	IO-Link Master (6ES7148-6JA00-0AB0).....	207
11.1.1	Parameters for IO-Link Master	214
11.1.2	Functions	216
11.2	IO-Link Master (6ES7148-6JD00-0AB0)	217
11.2.1	Configuration.....	222
11.2.2	Parameter	223
11.2.3	Functions	224
11.2.4	Interrupts.....	226
11.2.4.1	Triggering of a diagnostic interrupt	226
11.2.4.2	Triggering a hardware interrupt	227
11.2.4.3	Triggering of a pull/plug interrupt	227
11.2.5	Maintenance events.....	227
12	Terminal block and voltage distributor	229
12.1	Terminal block.....	229
12.2	Voltage distributor	231
A	Signal names	234
A.1	Signal names	234
B	Article numbers	235
C	Dimensional drawings	240
C.1	Dimensional drawings.....	240
D	Connection examples	246
D.1	Connection of resistance thermometers to the analog inputs	246
D.2	Connection of thermocouples to the analog inputs	247
E	I/O address space	250
F	Response times for analog input device and output device	258
F.1	Response times for analog input device.....	258
F.2	Response times for analog output device	259
G	Fail-safe shutdown of ET 200eco PN standard modules	261
G.1	Back-up oriented shutdown of ET 200eco PN standard modules	261
H	Open Source Software	263
H.1	Open Source Software.....	263
	Glossary	265
	Index	271

Product overview

1.1 Distributed I/O device – Overview

Distributed I/O systems – application area

A plant configuration quite often features a process I/O configuration in a central automation system.

The wiring of process I/O components installed at a grated distance away from an automation system may soon become highly complex and susceptible for electromagnetic interference.

Distributed I/O systems are the perfect solution for such configurations.

- The controller CPU is located in a central rack.
- The I/O systems (inputs and outputs) are operated locally in a distributed configuration.

What is PROFINET IO?

PROFINET IO is an open transmission system with real-time functionality defined in accordance with the PROFINET standard. This standard defines a manufacturer-independent communication, automation and engineering model.

Industrial-strength connections are available for wiring the PROFINET components.

- PROFINET discards the hierarchical PROFIBUS master/slave concept. and deploys a provider/consumer principle instead. The IO Devices that will be subscribed to by an IO Controller are defined within the planning phase.
- The quantity structures are extended in accordance with the available quantities for PROFINET IO. Parameter limits are not exceeded during configuration.
- The transmission rate is 100 Mbps.
- The configuration interface for users is generally the same as that for PROFIBUS DP (the system is configured in **STEP 7 > HW Config**).

Structure of a PROFINET IO network

The figure below illustrates a typical PROFINET IO network structure. Existing PROFIBUS slaves can be integrated using an IE/PB Link.

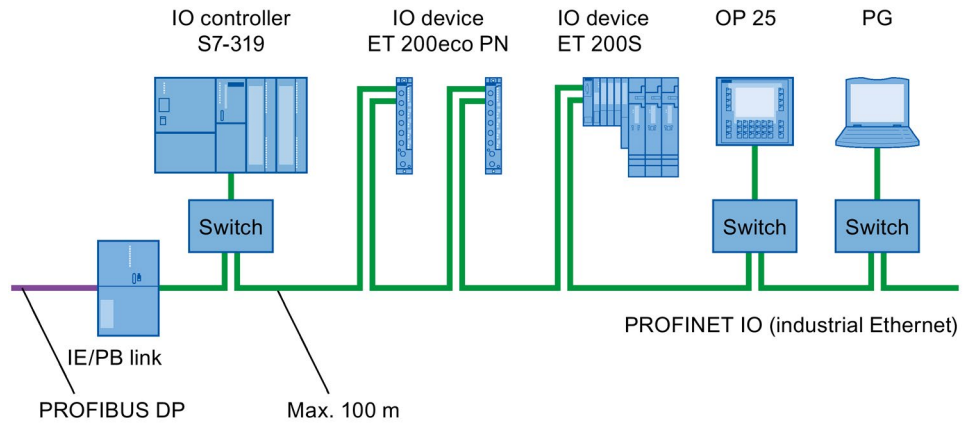

Figure 1-1 Typical structure of PROFINET IO

1.2 ET 200eco PN Distributed I/O Device

Definition

The ET 200eco PN distributed I/O device is a compact PROFINET IO device in degree of protection IP65/66 or IP67 and UL Enclosure Type 4x, Indoor use only.

Field of application

The fields of application of the ET 200eco PN are derived from its special properties.

- A robust design and degree of protection IP65/66 or IP67 make the ET 200eco PN distributed I/O device suitable in particular for use in rugged industrial environments.
- The compact design of the ET 200eco PN is particularly favorable for applications in confined areas.
- The easy handling of ET 200eco PN facilitates efficient commissioning and maintenance.

Properties

The ET 200eco PN has the following properties:

- Integrated switch with 2 ports
- Supported Ethernet services:
 - ping
 - arp
 - Network diagnostics (SNMP)
 - LLDP
 - DCP
- Interrupts
 - Diagnostics interrupts
 - Maintenance interrupts
 - Hardware interrupts
- Port diagnostics
- Isochronous real-time communication
- Prioritized startup
- Device replacement without programming device
- Media redundancy

Components of ET 200eco PN

The tables below provide an overview of the most important components of ET 200eco PN:

Table 1- 1 Components of ET 200eco PN (30 mm)

Component	Function	Figure
I/O device	<p>You connect the sensors and actuators to the I/O device. The I/O device is available in the following variants:</p> <ul style="list-style-type: none"> • 8 DI DC 24V 4×M12 • 8 DO DC 24V/1,3A 4×M12 • 8 DO DC 24V/0,5A 4×M12 	

① SF/MT LED

② BF LED

③ ON LED

④ DC 24V LED (for digital output device only)

⑤ P1 LK LED

⑥ P2 LK LED

⑦ Channel status/channel fault

⑧ X03: Voltage infeed

⑨ X02: Loop through of the voltage

⑩ Input/output signal

⑪ MAC address

⑫ X01 P2 LAN: PROFINET IO connection

⑬ X01 P1 LAN: PROFINET IO connection

Table 1- 2 Components of ET 200eco PN (60 mm)

Component	Function	Figure
I/O device	<p>You connect the sensors and actuators to the I/O device. The I/O device is available in the following variants:</p> <ul style="list-style-type: none"> • 8 DI DC 24V 8×M12 • 16 DI DC 24V 8×M12 • 8 DO DC 24V/1,3A 8×M12 • 8 DO DC 24V/2,0A 8×M12 • 16 DO DC 24V/1,3A 8×M12 • 8 AI 4 U/I + 4 RTD/TC 8×M12 • 8 AI RTD/TC 8×M12 • 8 DIO DC 24V/1,3A 8×M12 	

- | | |
|--------------------------------------------------------------------------------------------------------------------------------------------------------------------------------------------------------------------------------------------|-----------------------------------------------------------------------------------------------------------------------------------------------------------------------------------------------------------------------------------------------------------------------|
| <ul style="list-style-type: none"> ① SF/MT LED ② BF LED ③ ON LED ④ DC 24V LED (for digital output device only) ⑤ P1 LK LED ⑥ P2 LK LED ⑦ Channel status/channel fault | <ul style="list-style-type: none"> ⑧ X03: Voltage infeed ⑨ X02: Loop through of the voltage ⑩ Input/output signal ⑪ MAC address ⑫ X01 P2 LAN: PROFINET IO connection ⑬ X01 P1 LAN: PROFINET IO connection |
|--------------------------------------------------------------------------------------------------------------------------------------------------------------------------------------------------------------------------------------------|-----------------------------------------------------------------------------------------------------------------------------------------------------------------------------------------------------------------------------------------------------------------------|

Table 1- 3 Components of ET 200eco PN (60 mm)

Component	Function	Figure
I/O device	<p>You connect the sensors and actuators to the I/O device. The I/O device is available in the following variants:</p> <ul style="list-style-type: none"> • 4 AO U/I 4×M12 	

- | | |
|--------------------------------|--------------------------------------|
| ① SF/MT LED | ⑦ X03: Voltage infeed |
| ② BF LED | ⑧ X02: Loop through of the voltage |
| ③ ON LED | ⑨ Input/output signal |
| ④ P1 LK LED | ⑩ MAC address |
| ⑤ P2 LK LED | ⑪ X01 P2 LAN: PROFINET IO connection |
| ⑥ Channel status/channel fault | ⑫ X01 P1 LAN: PROFINET IO connection |

What is an IO-Link Master?

IO-Link is a point-to-point connection to conventional and intelligent sensors/actuators via unshielded standard cable in proven 3- or 5-conductor technology. IO-Link Masters are backwards compatible with all DI standard sensors. Switching state and data channel designed in proven 24 VDC technology.

Supports mixed operation of sensors/actuators in the IO-Link, digital input and digital output operating modes on all four ports of the IO-Link Master.

Table 1- 4 IO-Link Master (6ES7148-6JA00-0AB0)

Component	Function	Figure
IO-Link master	Connect the following to I/O device: <ul style="list-style-type: none"> • X1 to X4: IO-Link Devices or sensors/actuators • X5, X6: Sensors • X7, X8: Actuators 	

- | | |
|------------------------------------------------|----------------------------------------|
| ① SF/MT LED | ⑩ X03: Voltage infeed |
| ② BF LED | ⑪ X02: Loop through of the voltage |
| ③ ON LED | ⑫ X7/X8: Output signal |
| ④ DC 24V LED | ⑬ X5/X6: Input signal |
| ⑤ P1 LK LED | ⑭ MAC address |
| ⑥ P2 LK LED | ⑮ X1 to X4: IO-Link ports/input signal |
| ⑦ Status display / Communication | ⑯ X01 P2 LAN: PROFINET IO connection |
| ⑧ Digital input: Channel status/channel fault | ⑰ X01 P1 LAN: PROFINET IO connection |
| ⑨ Digital output: Channel status/channel fault | |

Table 1- 5 IO-Link Master (6ES7148-6JD00-0AB0)

Component	Function	Figure
IO-Link master	Connect IO-Link devices or encoders/actuators to the I/O device.	

- ① SF/MT LED
- ② BF LED
- ③ ON LED
- ④ DC 24V LED
- ⑤ P1 LK LED
- ⑥ P2 LK LED
- ⑦ Q1 ... Q4: Channel status in the SIO mode
- ⑧ IO-L1 ... IO-L4: Channel status/channel fault IO-Link communication
- ⑨ X03: Voltage infeed
- ⑩ X02: Loop through of the voltage
- ⑪ X1 to X4: IO-Link ports
- ⑫ MAC address
- ⑬ X01 P2 LAN: PROFINET IO connection
- ⑭ X01 P1 LAN: PROFINET IO connection

LEDs

For information on the meaning of the LED displays, see section Diagnostics by means of LED display (Page 85).

Further components of ET 200eco PN

Table 1- 6 Further components of ET 200eco PN

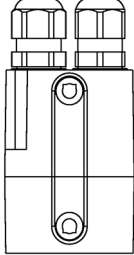
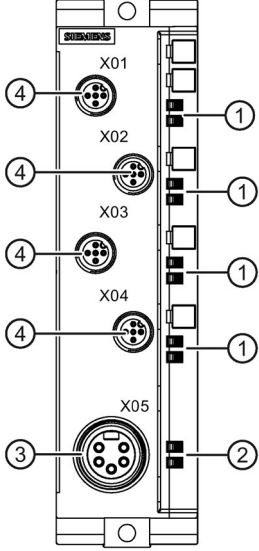
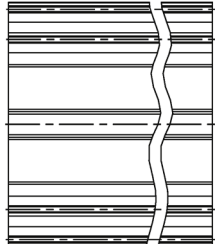
Component	Function	Figure
Terminal block	You can connect up to 10 A per voltage to the terminal block for distribution to the I/O devices. A maximum of 4 A per voltage is available short-circuit protected for each I/O device.	
Voltage distributor	You can supply up to 8 A per voltage at the PD DC 24V 1×7/8" 4×M12 and distribute up to 4 A per voltage and connector short-circuit-protected through 4 connectors.	 <p data-bbox="991 1306 1374 1485"> ① LEDs for forwarding 1L/2L ② LEDs for forwarding 1L/2L ③ X05: Status of voltage supply ④ X01 ... X04: Loop through of the voltage </p>
Mounting rail	You can install several I/O devices on the mounting rail.	

IO Controller

The ET 200eco PN can communicate with all IO controllers that conform to IEC 61158.

At least STEP 7 V5.4, SP4 is required to configure a ET 200eco PN.

The ET 200eco PN can be configured starting from a CPU with extended diagnostics, see FAQ (<https://support.automation.siemens.com/WW/view/en/23678970>).

For information on the individual PROFINET properties that are available for the respective versions of the ET 200eco PN, refer to theFAQ (<https://support.automation.siemens.com/WW/view/en/44383954>).

Installing

Two installation variants

There are two installation variants:

- With mounting rail
- Without mounting rail

For corresponding conditions, refer to the next chapters.

2.1 Installation without mounting rail

Simple installation

The ET 200eco PN distributed I/O device is designed for easy installation.

- The I/O device must be mounted on a solid base
- and can be prewired.

Requirements

Screw type	Explanation
Cylinder head screw M5 to ISO 1207/ISO 1580 (DIN 84/DIN85)	Minimum screw length: 30 mm. Any washers you might need should conform to DIN 125.
Hexagon socket head cap screws M5 to DIN EN ISO 4762	

Tools required

Medium-sized screwdriver or 4 mm hex socket driver.

Procedure

1. Screw the I/O device onto a level surface.

Screw the I/O device onto the panel at both mounting fixtures on the top and bottom of the front or side (torque: 3 N/m).

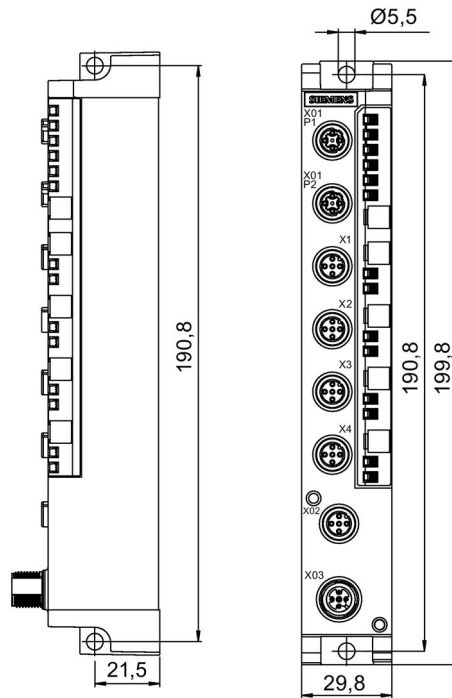

Figure 2-1 Mounting the I/O device on a panel (30 mm)

2.1 Installation without mounting rail

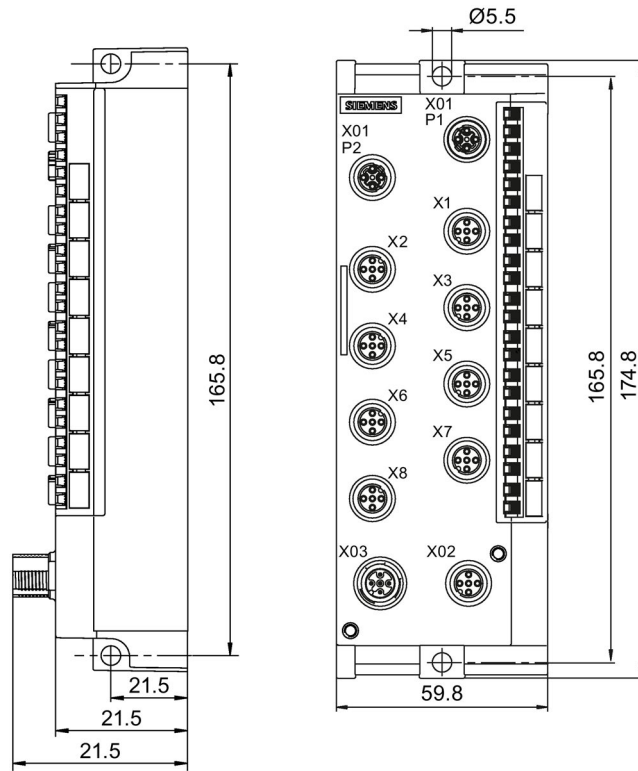

Figure 2-2 Mounting the I/O device on a panel (60 mm), for example 16 DO DC 24V/1,3A 8×M12

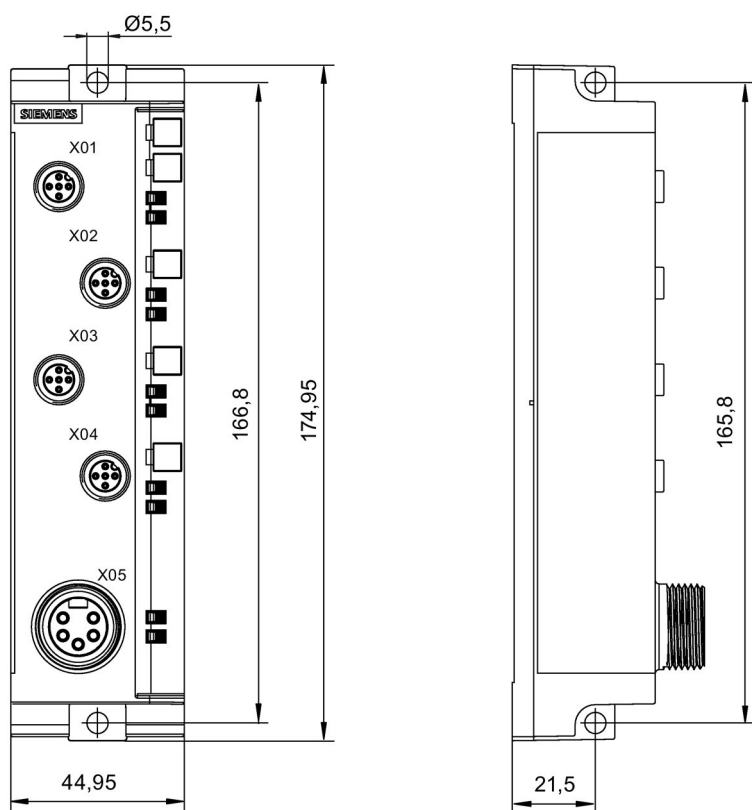

Figure 2-3 Mounting the PD DC 24V 1x7/8" 4xM12 on a panel (45 mm)

2.2 Installation with mounting rail

Version

The mounting rail is available with a length of 500 mm.

Installing the mounting rail

Cut the 500-mm rail to suit your requirements and drill mounting holes for the M8 screws. You should distribute the mounting holes evenly at a pitch of 182 mm on the rail, starting at a distance of 12 mm from the edge.

Use the rack screw to bolt the I/O devices onto the mounting rail.

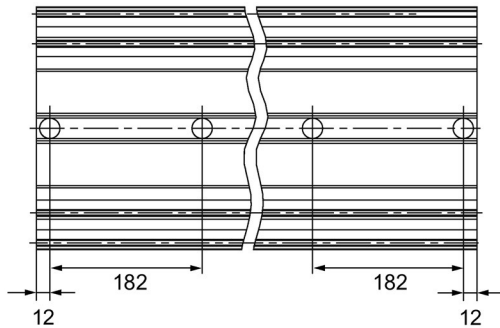

Figure 2-4 Installing the mounting rail

2.3 Mounting position, mounting dimensions

Mounting position

The ET 200eco PN can be mounted in any position.

Mounting and clearance dimensions

Table 2- 1 Mounting dimensions

	Dimensions	
	single width	double width
Mounting width	30 mm	60 mm
Mounting height	200 mm	175 mm
Mounting depth	49 mm	49 mm

2.4 Installing the terminal block

Properties

The terminal block connects the ET 200eco PN and supplies the I/O device with power.

The terminal block

- can be installed separately,
- or be screwed on to each I/O device.

Requirements

Note that you must wire the terminal block before you install it.

Tools required

Recessed head screwdriver, medium size

Installing the terminal block separately

You install the terminal block separately.

Remove the screws and then screw them in again at the bottom of the housing.

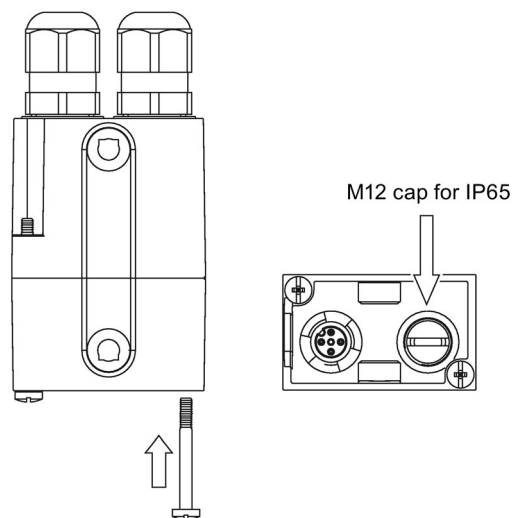

Figure 2-5 Installing the terminal block separately

Installing the terminal block on an I/O device

Install the terminal block vertically on a housing of 30 mm width, or horizontally on a housing of 60 mm width.

An M12 cap is attached to the bottom of the terminal block to implement the corresponding degree of protection. Make sure that the M12 cap is not attached to the terminal block connector and that it is mounted onto connector X02 of the I/O device. Bolt the terminal block onto the I/O device by tightening the screws.

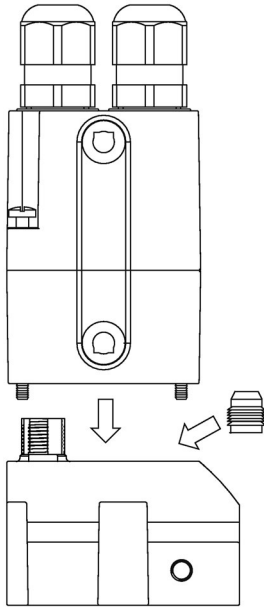

Figure 2-6 Installing the terminal block on an I/O device of 60 mm width

See also

Terminal block (Page 229)

Wiring the terminal block (Page 59)

2.5 Replacing labels

Properties

You can identify the I/O device and the I/O connectors using the labels. The module is supplied with the labels already clipped into the holder.

- 1 for the I/O device
- 4 or 8 for the I/O connectors

Requirements

You can order replacement labels.

Tools required

2.5 to 4 mm slotted screwdriver

Replacing labels

1. Push the screwdriver into the small opening of the label at an angle and then lever it out.

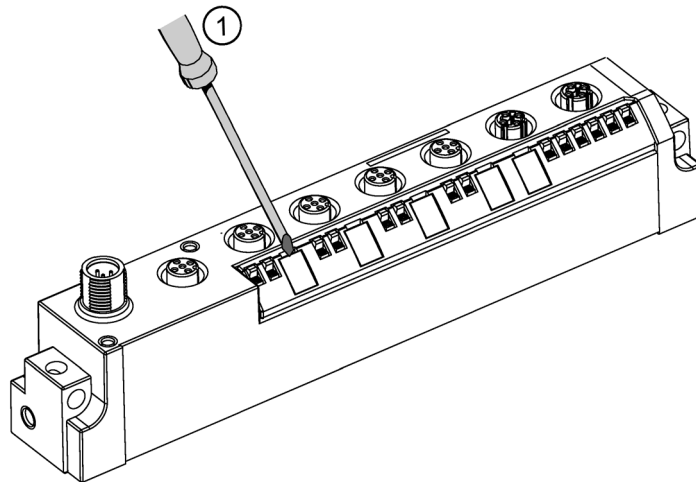

Figure 2-7 Removing labels

2. Push the new label into the holder on the device.

2.6 Removing ET 200eco PN

Procedure

The ET 200eco PN is wired up and operating.

1. Switch off the supply voltage to the ET 200eco PN.
2. Disconnect the wiring from the I/O device.
3. Remove the fixing screws from the I/O device.

Note

Observe the information in chapter Looping PROFINET and the supply voltage (Page 66) when replacing the I/O device.

Wiring

3.1 General rules and regulations for operating an ET 200eco PN

Introduction

When operating the ET 200eco PN distributed I/O device as part of a plant or system, special rules and regulations have to be followed depending on the field of application.

This section provides an overview of the most important rules you have to observe when integrating the ET 200eco PN distributed I/O device in a plant or system.

EMERGENCY-STOP equipment

EMERGENCY STOP equipment according to IEC 204 (corresponds to DIN VDE 113) must remain effective in all operating modes of the plant or system.

System startup after specific events

The table below identifies situations you must pay attention to when the system starts up after the occurrence of certain events.

If ...	then ...
Startup follows a power dip / failure Startup of the ET 200eco PN after bus communication has been interrupted	Dangerous operating states must be avoided at all times. If necessary, force an "EMERGENCY OFF"!
Startup after releasing the EMERGENCY OFF equipment	Any uncontrolled or undefined startup must be avoided.

24 V DC supply

The table shows what you have to observe for the 24 V DC supply.

At ...	Requirements ...	
Buildings	external lightning protection	take lightning protection measures (for example, lightning protection elements)
24 VDC supply lines, signal lines	internal lightning protection	
24 V DC supply	safe (electrical) isolation of the extra-low voltage	
Loop-through of supply voltage	Voltage drop in the case of loop-through (see Chapter Looping PROFINET and the supply voltage (Page 66))	

Protection against external electrical interference

The table below shows what to observe in order to protect the system against electrical interference or faults.

At ...	ensure that ...
all plants or systems in which the ET 200eco PN is installed	the plant or system is EMC-compatible and properly grounded for the discharge of electromagnetic interference.
supply, signal, and bus lines	the wiring arrangement and installation is correct.
signal and bus lines	a wire break or conductor break does not result in undefined states of the plant or system.

3.2 Operating ET 200eco PN on grounded mains

Introduction

This section provides information about the overall configuration of an ET 200eco PN distributed I/O device with a grounded infeed (TN-S system). The focus in this is set in particular on: disconnecting devices and short-circuit and overload protection according to DIN VDE 0100 and DIN EN 60204-1.

Supply voltages of the ET 200eco PN

There are two supply voltages:

- 1L+ Non-switched supply voltage (electronic/sensor/load supply)
- 2L+: Switched supply voltage (load voltage supply)

Definition: Grounded infeed

The neutral conductor of a TN-S system is always bonded to ground. A simple short-circuit to ground of a live conductor, or of a grounded component of the plant will trip the disconnecting devices.

Safe electrical isolation (SELV/PELV according to IEC 60364-4-41)

The ET 200eco PN may only be operated using power supplies/power supply units with safe electrical isolation.

Components and protective measures

Various components and protective measures are stipulated for plant installation. The type of components and the degree to which the protective measures are mandatory depend on the DIN VDE regulation that applies to your plant configuration. The next table refers to the diagram below.

Compare ...	Reference to the diagram	DIN VDE 0100	DIN EN 60204
Disconnecting device for controller, sensors, and actuators	(1) "Grounding concept for ET 200eco PN"	... Part 460: Main switch	... Part 1: Disconnect switch
Short-circuit and over-load protection	(2) "Grounding concept for ET 200eco PN"	... Part 725: Single-pole protection of circuits	... Part 1: with grounded secondary power circuit: single-pole protection
Line protection		... Part 430: Protection of cables and lines against over-current	-

Safe electrical isolation

Safety isolation is required for:

- Modules which must be supplied with ≤ 60 V DC or ≤ 25 V AC
- 24 V DC load circuits

Configuring ET 200eco PN with grounded reference potential

Any interference currents generated within an ET 200eco PN configuration with grounded reference potential are discharged to protective earth. The terminals must be connected externally (see the figure "Grounding concept for ET 200eco PN": Connection between 1M and FE).

Configuring ET 200eco PN with ungrounded reference potential

In an ET 200eco PN configuration with ungrounded reference potential, any interference currents will be discharged to protective ground via an internal RC circuit (see the figure "Grounding concept for ET 200eco PN": **No** connection between 1M and FE).

Isolation monitoring

Isolation monitoring must be provided if:

- Ungrounded ET 200eco PN configuration
- A repetitive error is liable to cause dangerous plant states

ET 200eco PN in its overall configuration

The figure below shows the overall configuration of the ET 200eco PN distributed I/O device (load voltage supply and grounding concept) with infeed from a TN-S system.

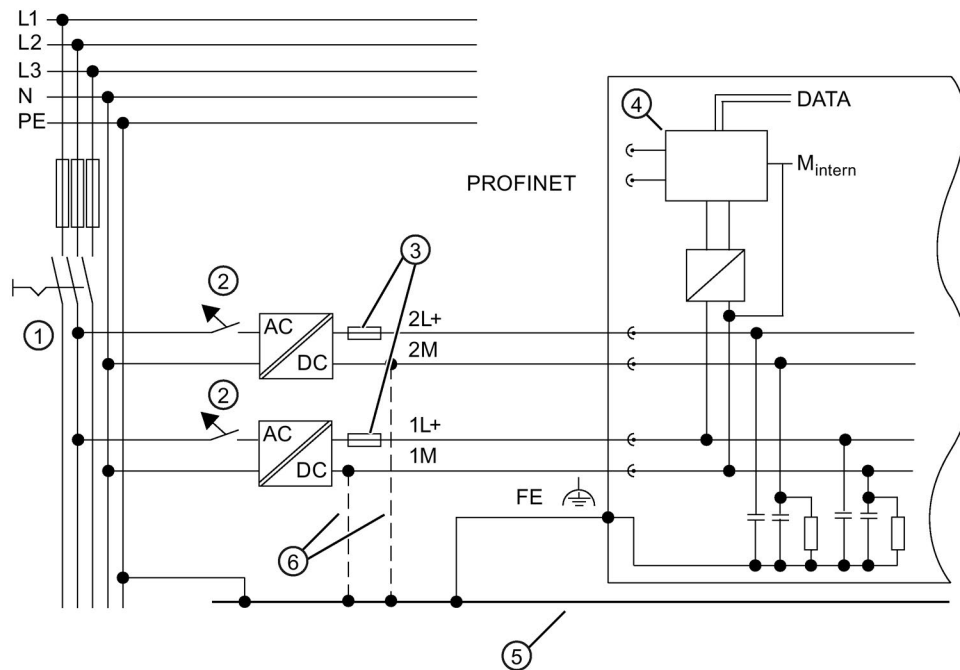

- ① Disconnecting device for controller, sensors, and actuators
- ② Short-circuit and overload protection
- ③ Fuses for line protection
- ④ Microprocessor and switch
- ⑤ Main ground line
- ⑥ When the ET 200eco PN is configured with ungrounded reference potential, the connection between 1M and FE and 2M and FE is eliminated.

3.3 Electrical configuration of ET 200eco PN

Electrical isolation

The ET 200eco PN electrical configuration features electrical isolation between:

- 1L+ Non-switched supply voltage (electronic/sensor/load supply)
Electrically isolated from PROFINET IO and 2L+ (load voltage supply)
- 2L+: Switched supply voltage (load voltage supply):
Electrically isolated from all other circuit components.
Can be shut down with influencing the 1L+.
- PROFINET IO interface:
Electrically isolated from all other circuit components.

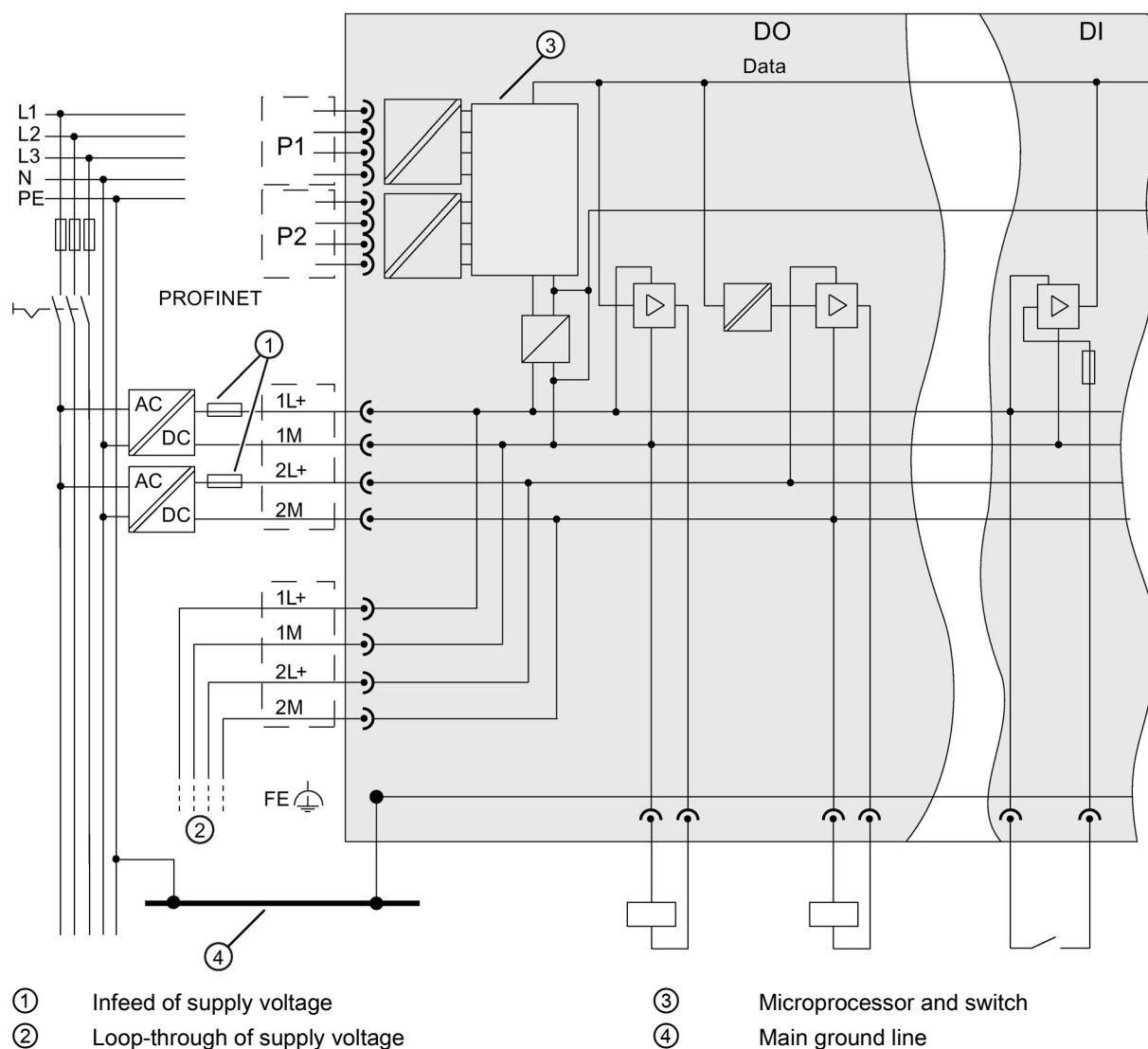

Connection of a digital output to a digital input

 **WARNING**

When a digital output is connected to a digital output, the respective potential groups have to be observed. Depending on the configuration, 1M and 2M may then be connected, resulting in elimination of the galvanic isolation between 1L+ and 2L+.

Line protection

Line protection is required in accordance with DIN VDE 0100, i.e., you must always provide external fusing.

The power supplies of the I/O device must be fused using a 24 V DC/4 A miniature circuit breaker with tripping characteristic type B or C.

The power supplies of the terminal block must be fused using a 24 V DC/10 A miniature circuit breaker with tripping characteristic type B or C.

The power supplies of the voltage distributor must be fused using a 24 VDC / 8 A miniature circuit breaker with tripping characteristic type B or C.

3.4 Technical specifications of the lines

Influence of cable length on the supply voltage

- If you are wiring your configuration, then you must take into account the impact of cable length on the supply voltage to the ET 200eco PN.

Example

A 10-m cable with $\varnothing 0.75 \text{ mm}^2$ has a resistance of 0.5Ω , which corresponds with a voltage drop of 2 V at a load of 4 A.

 **CAUTION**

If you do not adhere to the maximum infeed currents and the cable cross-sections required for these currents, you will risk overheating the cable insulation and contacts, and damage to the device.

3.5 Wiring the ET 200eco PN

3.5.1 Wiring the ET 200eco PN to functional earth (FE)

Introduction

You must connect the ET 200eco PN with the functional earth (FE).

What is functional ground?

All ET 200eco PN I/O devices have a functional earth connection. This connection is used to suppress interference but not for protective purposes. You establish a directional electrical connection to a point in your plant or a shield using the functional earth connection. EMC interference is discharged directly to earth through this connection. The interference immunity of the entire I/O device is increased by the discharge of the EMC interference.

Install ET 200eco PN I/O devices on conductive base

Requirements

Conductive base for installation of the I/O device.

Tools required

You need the following tools to connect to the functional ground:

- Screwdriver

Required accessories

You need the following accessories to connect to the functional ground:

- 2 x M5 x 8 fixing screws and washers

Installation

To connect ET 200eco PN I/O devices to functional earth with conductive base, follow these steps:

- Drill 2 fixing holes.
- Bolt the I/O device with the M5 fixing screws and washers using a torque of 1.5 Nm.

Note

Grounding with conductive base

When you fasten an I/O device of ET 200eco PN to a conductive, grounded base, the lower fixing screw creates a conductive connection to the ground potential.

Make sure there is a low-impedance connection between the peripheral device and the conductive substrate and between the conductive substrate and the functional ground.

Install ET 200eco PN I/O devices on non-conductive base

Requirements

Non-conductive base for installation of the I/O device.

Tools required

You need the following tools to connect to the functional ground:

- Stripping tool
- Crimp tool
- Screwdriver

Required accessories

You need the following accessories to connect to the functional ground:

- M5 x 8 fixing screw and washers
- Grounding cable (copper braid cable) with a minimum cross-section of 4 mm²
- Cable lug suitable for M5 screws

Installation

To connect ET 200eco PN I/O devices to functional earth with non-conductive base, follow these steps:

- Drill 2 fixing holes.
- Strip the grounding conductor and crimp on the cable lug.
- Screw the cable lug onto the I/O device and voltage distributor (M5 fixing screw) with a torque of 1.5 Nm.

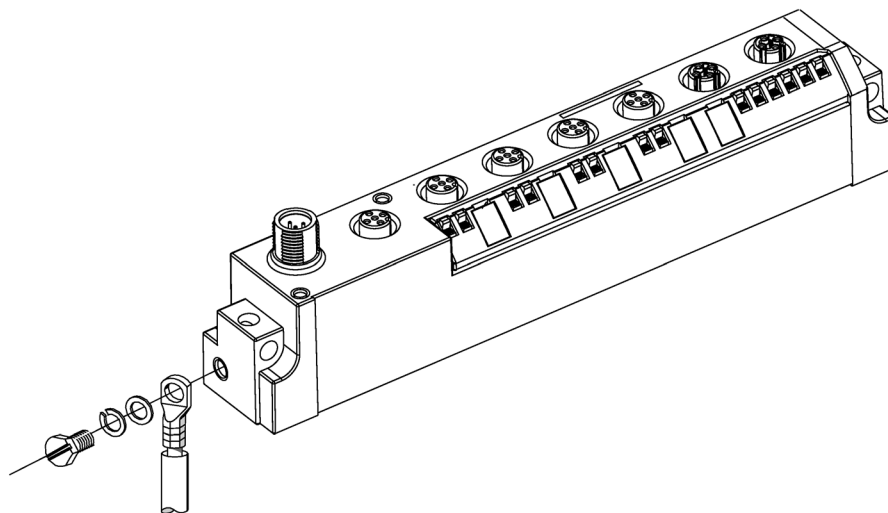

Figure 3-1 Wiring the I/O device to functional earth

Reference

For additional information on installing I/O devices, refer to the section Installing (Page 20).

3.5.2 Wiring I/O devices

Properties

Connect the sensors and actuators to the 5-pin M12 circular sockets (X1 to X4, or X1 to X8) on the front panel of the I/O device.

Requirements

Shut off the supply voltage before you wire the I/O devices.

Tools required

Stripping tool and screwdriver for wiring the M12 cable connector, if you do not use prefabricated cables.

Required accessories

- Prefabricated cable with 5-pin M12 cable connector
- or 3-, 4-, or 5-wire copper cable (conductor cross-section must be $\leq 0.75 \text{ mm}^2$) with 5-pin M12 cable connector (see the tables below).
- or a Y cable
- M12 sealing caps

You can find the article numbers in the appendixArticle numbers (Page 235).

Connecting the M12 connector

1. Plug the connector into the relevant circular socket connector on the I/O block. Make sure the connectors and sockets are properly interlocked (matched joint).
2. Secure the connector by tightening the knurled ring nut with a torque of 1.5 Nm.

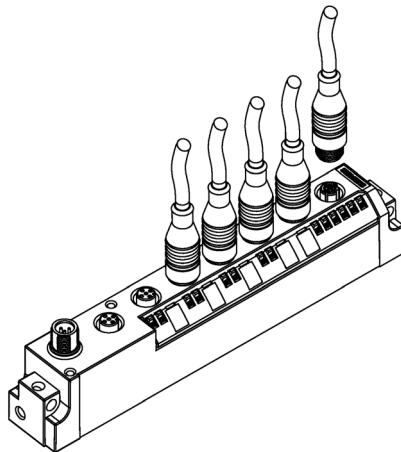

Figure 3-2 Connecting the M12 connector

Y cable

The Y cable allows you to connect two actuators or sensors to the inputs or outputs of the ET 200eco PN.

The use of the Y cable is particularly recommended when two channels are occupied for each socket of an I/O device. The Y cable divides the two channels for two jacks (for pin assignment, see the tables below).

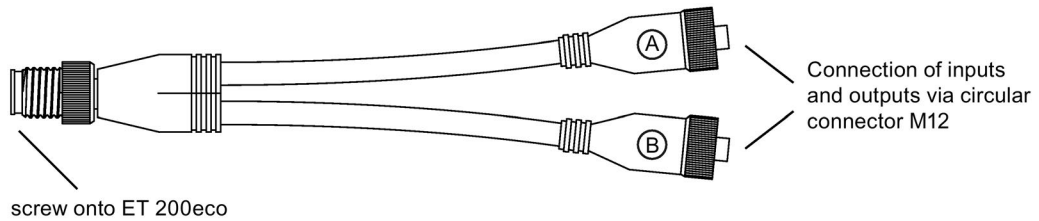
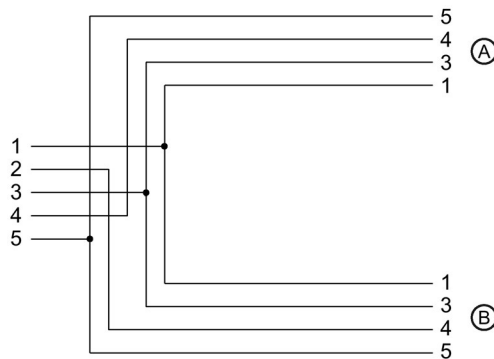

Figure 3-3 Y cable

The wiring of the Y cable is shown below.



Wiring jacks (DI/DQ) for Y cable

To connect digital inputs via a Y cable, you will need:

- A Y cable
- 2 M12 jacks
- A flexible 3-wire or 4-wire copper cable with a wire cross-section of $\leq 0.75 \text{ mm}^2$

The assignment of Pin 4 depends on which socket of the ET 200eco PN the Y cable is screwed to.

Pin assignment of the sockets for inputs/outputs

The pin assignment of the sockets for inputs/outputs can be found in the data for the individual I/O devices starting in section Pin assignment of digital inputs (Page 41).

Wiring M12 jacks for analog inputs and analog outputs

For the connection of analog inputs and outputs, you will need:

- one 4-pin or 5-pin M12 jack
- a shielded 4-wire copper cable with a wire cross-section of $\leq 0.75 \text{ mm}^2$

Wire the jack according to the pin assignment of the sockets on the I/O device. You can find the pin assignment in the data for the individual I/O devices starting in Chapter Pin assignment for analog inputs (Page 52).

Sealing round sockets not in use

Always seal all unused round sockets using M12 sealing caps to achieve degree of protection IP65, IP66 or IP67.

You can find the article numbers in the appendix Article numbers (Page 235).

Pin assignment

The pin assignment of the I/O devices is specified in the following chapters.

3.6 Pin assignment of connectors

3.6.1 Pin assignment of the PROFINET connector

PROFINET connector, X01 connector, port 1 and port 2

The tables below list the pin assignment for the PROFINET connectors.

Table 3- 1 Pin assignment of the M12 cable connector for PROFINET connector, ports 1 and 2

Pin	Assignment	View of the cable connector (PROFINET), port 1 and port 2
	Assignment X01 P1	
1	TXP	
2	RXP	
3	TXN	
4	RXN	
Thread	Functional earth FE	
	Assignment X01 P2	
1	RXP	
2	TXP	
3	RXN	
4	TXN	
Thread	Functional earth FE	

Note

Note the different pin assignments for X01 P1 and X01 P2 if you disable "Autonegotiation" in *STEP 7*.

3.6.2 Pin assignment for feeding and looping the voltage

Cable connector for supply voltage infeed, X03 connector

The table below lists the pin assignment for the supply voltage infeed.

Table 3- 2 Pin assignment of the M12 cable connector for the supply voltage infeed

Pin	Assignment	View of the cable connector (wiring side)
1	Supply voltage 1L+ (non-switched)	
2	Ground 2M (switched)	
3	Ground 1M (non-switched)	
4	Supply voltage 2L+ (switched)	
5	Reserved	

Cable connector for loop-through of the supply voltage, X02 socket

The following table lists the supply voltage for loop-through of the supply voltage.

Table 3- 3 Pin assignment of the M12 cable connector for loop-through of the voltage

Pin	Assignment	View of the cable connector (wiring side)
1	Supply voltage 1L+ (non-switched)	
2	Ground 2M (switched)	
3	Ground 1M (non-switched)	
4	Supply voltage 2L+ (switched)	
5	Reserved	

Note

The M12 sockets for the supply and I/O have the same coding.

Make sure that you wire the supply and the I/O correctly.

 CAUTION
PROFINET IO
Modules with PROFINET interfaces may only be operated if all of the connected nodes are equipped with SELV/PELV power supplies (or with protection systems of equal quality).

3.6.3 Pin assignment of digital inputs

I/O device 8 DI DC 24V 4×M12 (6ES7141-6BF00-0AB0)

You will find the pin assignment for the 8 DI DC 24V 4×M12 I/O device in the table below.

Table 3- 4 Pin assignment of the M12 cable connector for the 8 DI DC 24V 4×M12 I/O device

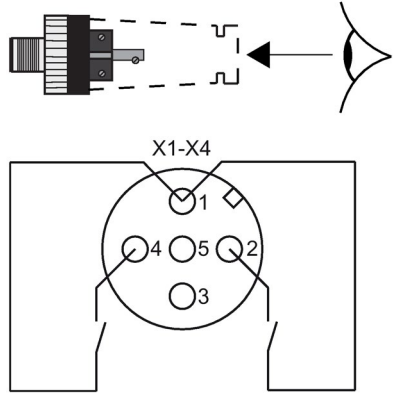
Pin	Assignment of X1 to X4	View of the cable connector (wiring side)
1	24 V sensor supply 1Us (derived from 1L+ non-switched)	
2	Input signal DI ₄ : Connector X1 Input signal DI ₅ : Connector X2 Input signal DI ₆ : Connector X3 Input signal DI ₇ : Connector X4	
3	Sensor supply ground 1M	
4	Input signal DI ₀ : Connector X1 Input signal DI ₁ : Connector X2 Input signal DI ₂ : Connector X3 Input signal DI ₃ : Connector X4	
5	Functional earth FE	

When using the Y cable, pin 2 and pin 4 are assigned to pin 4 (A) and pin 4 (B).

I/O device 8 DI DC 24V 8×M12 (6ES7141-6BG00-0AB0)

You will find the pin assignment for the 8 DI DC 24V 8×M12 I/O device in the table below.

Table 3- 5 Pin assignment of the M12 cable connector for the 8 DI DC 24V 8×M12 I/O device

Pin	Assignment of X1 to X8	View of the cable connector (wiring side)
1	24 V sensor supply 1Us (derived from 1L+ non-switched)	
2	Not used	
3	Sensor supply ground 1M	
4	Input signal DI ₀ : Connector X1 Input signal DI ₁ : Connector X2 Input signal DI ₂ : Connector X3 Input signal DI ₃ : Connector X4 Input signal DI ₄ : Connector X5 Input signal DI ₅ : Connector X6 Input signal DI ₆ : Connector X7 Input signal DI ₇ : Connector X8	
5	Functional earth FE	

I/O device 16 DI DC 24V 8×M12 (6ES7141-6BH00-0BA0)

You will find the pin assignment for the 16 DI DC 24V 8×M12 I/O device in the table below.

Table 3- 6 Pin assignment of the M12 cable connector for the 16 DI DC 24V 8×M12 I/O device

Pin	Assignment of X1 to X8	View of the cable connector (wiring side)
1	24 V sensor supply 1Us (derived from 1L+ non-switched)	
2	Input signal DI ₈ : Connector X1 Input signal DI ₉ : Connector X2 Input signal DI ₁₀ : Connector X3 Input signal DI ₁₁ : Connector X4 Input signal DI ₁₂ : Connector X5 Input signal DI ₁₃ : Connector X6 Input signal DI ₁₄ : Connector X7 Input signal DI ₁₅ : Connector X8	
3	Sensor supply ground 1M	
4	Input signal DI ₀ : Connector X1 Input signal DI ₁ : Connector X2 Input signal DI ₂ : Connector X3 Input signal DI ₃ : Connector X4 Input signal DI ₄ : Connector X5 Input signal DI ₅ : Connector X6 Input signal DI ₆ : Connector X7 Input signal DI ₇ : Connector X8	
5	Functional earth FE	

When using the Y cable, pin 2 and pin 4 are assigned to pin 4 (A) and pin 4 (B).

Note

The M12 sockets for the supply and I/O have the same coding.

Make sure that you wire the supply and the I/O correctly.

3.6.4 Pin assignment of digital outputs

I/O device 8 DO DC 24V/1,3A 4×M12 (6ES7142-6BF00-0AB0)

You will find the pin assignment for the 8 DO DC 24V/1,3A 4×M12 I/O device in the table below.

Table 3- 7 Pin assignment of the M12 cable connector for the 8 DO DC 24V/1,3A 4×M12 I/O device

Pin	Assignment	View of the cable connector (wiring side)
Assignment X1 and X2 (1L+ non-switched)		
1	Not used	
2	Output signal DQ ₄ : Connector X1 Output signal DQ ₅ : Connector X2	
3	Supply ground 1M	
4	Output signal DQ ₀ : Connector X1 Output signal DQ ₁ : Connector X2	
5	Functional earth FE	
Assignment X3 and X4 (2L+ switched)		
1	Not used	
2	Output signal DQ ₆ : Connector X3 Output signal DQ ₇ : Connector X4	
3	Supply ground 2M	
4	Output signal DQ ₂ : Connector X3 Output signal DQ ₃ : Connector X4	
5	Functional earth FE	

When using the Y cable, pin 2 and pin 4 are assigned to pin 4 (B) and pin 4 (A).

I/O device 8 DO DC 24V/0,5A 4×M12 (6ES7142-6BF50-0AB0)

You will find the pin assignment for the 8 DO DC 24V/0,5A 4×M12 I/O device in the table below.

Table 3- 8 Pin assignment of the M12 cable connector for the 8 DO DC 24V/0,5A 4×M12 I/O device

Pin	Assignment X1 to X4 (2L+ switched)	View of the cable connector (wiring side)
1	Not used	
2	Output signal DQ ₄ : Connector X1 Output signal DQ ₅ : Connector X2 Output signal DQ ₆ : Connector X3 Output signal DQ ₇ : Connector X4	
3	Supply ground 2M	
4	Output signal DQ ₀ : Connector X1 Output signal DQ ₁ : Connector X2 Output signal DQ ₂ : Connector X3 Output signal DQ ₃ : Connector X4	
5	Not used	

When using the Y cable, pin 2 and pin 4 are assigned to pin 4 (B) and pin 4 (A).

3.6 Pin assignment of connectors

I/O device 8 DO DC 24V/1,3A 8×M12 (6ES7142-6BG00-0AB0) and 8 DO DC 24V/2,0A 8×M12 (6ES7142-6BR00-0AB0)

The table below shows the pin assignments for I/O devices 8 DO DC 24V/1,3A 8×M12 and 8 DO DC 24V/2,0A 8×M12.

Table 3- 9 Pin assignment of the M12 cable connector for I/O device 8 DO DC 24V/1,3A 8×M12 and 8 DO DC 24V/2,0A 8×M12

Pin	Assignment	View of the cable connector (wiring side)
Assignment X1 to X4 (1L+ non-switched)		
2	Not used	
3	Supply ground 1M	
4	Output signal DQ ₀ : Connector X1 Output signal DQ ₁ : Connector X2 Output signal DQ ₂ : Connector X3 Output signal DQ ₃ : Connector X4	
5	Functional earth FE	
Assignment X5 to X8 (2L+ switched)		
1	Not used	
2	Not used	
3	Supply ground 2M	
4	Output signal DQ ₄ : Connector X5 Output signal DQ ₅ : Connector X6 Output signal DQ ₆ : Connector X7 Output signal DQ ₇ : Connector X8	
5	Functional earth FE	

I/O device 16 DO DC 24V/1,3A 8×M12 (6ES7142-6BH00-0AB0)

You will find the pin assignment for the 16 DO DC 24V/1,3A 8×M12 I/O device in the table below.

Table 3- 10 Pin assignment of the M12 cable connector for the 16 DO DC 24V/1,3A 8×M12 I/O device

Pin	Assignment	View of the cable connector (wiring side)
	Assignment X1 to X4 (1L+ non-switched)	
1	Not used	
2	Output signal DQ ₈ : Connector X1 Output signal DQ ₉ : Connector X2 Output signal DQ ₁₀ : Connector X3 Output signal DQ ₁₁ : Connector X4	
3	Supply ground 1M	
4	Output signal DQ ₀ : Connector X1 Output signal DQ ₁ : Connector X2 Output signal DQ ₂ : Connector X3 Output signal DQ ₃ : Connector X4	
5	Functional earth FE	
	Assignment X5 to X8 (2L+ switched)	
1	Not used	
2	Output signal DQ ₁₂ : Connector X5 Output signal DQ ₁₃ : Connector X6 Output signal DQ ₁₄ : Connector X7 Output signal DQ ₁₅ : Connector X8	
3	Supply ground 2M	
4	Output signal DQ ₄ : Connector X5 Output signal DQ ₅ : Connector X6 Output signal DQ ₆ : Connector X7 Output signal DQ ₇ : Connector X8	
5	Functional earth FE	

3.6 Pin assignment of connectors

When using the Y cable, pin 2 and pin 4 are assigned to pin 4 (B) and pin 4 (A).

Note

The M12 sockets for the supply and I/O have the same coding.

Make sure that you wire the supply and the I/O correctly.

3.6.5 Pin assignment for parameterizable digital input/digital output

I/O device 8 DIO DC 24V/1,3A 8×M12 (6ES7147-6BG00-0AB0)

You will find the pin assignment for the 8 DIO DC 24V/1,3A 8×M12 I/O device in the table below.

Table 3- 11 Pin assignment of the M12 cable connector for the 8 DIO DC 24V/1,3A 8×M12 I/O device

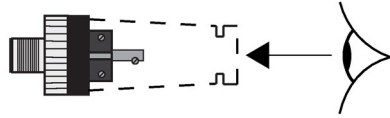
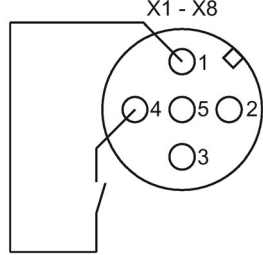
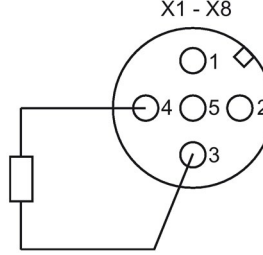
Pin	Assignment	View of the cable connector (wiring side)
Assignment X1 to X4 (1L+ non-switched)		
1*	24 V sensor supply 1Us (derived from 1L+ non-switched)	
2	Not used	
3	Supply ground 1M	
4	Input / output signal DIQ ₀ : Connector X1 Input/output signal DIQ ₁ : Connector X2 Input/output signal DIQ ₂ : Connector X3 Input/output signal DIQ ₃ : Connector X4	
5	Functional earth FE	<p>Input</p> 
Assignment X5 to X8 (2L+ switched)		
1	24 V sensor supply 2Us (derived from 2L+ switched)	
2	Not used	
3	Supply ground 2M	
4	Input / output signal DIQ ₄ : Connector X5 Input/output signal DIQ ₅ : Connector X6 Input/output signal DIQ ₆ : Connector X7 Input/output signal DIQ ₇ : Connector X8	
5	Functional earth FE	<p>Output</p> 
<p>* The sensor supply is only available when the corresponding channel is parameterized as an "Input".</p>		

3.6.6 Pin assignment for IO-Link Masters

IO-Link Master 4 IO-L + 8 DI + 4 DO DC 24V/1,3A 8×M12 (6ES7148-6JA00-0AB0)

The following tables contain the pin assignments for the IO-Link Master 4 IO-L + 8 DI + 4 DO DC 24V/1,3A 8×M12.

Table 3- 12 Pin assignment for IO-Link Master and digital inputs

Pin	Assignment of X1 to X4	View of the cable connector (wiring side)
1	24 V sensor supply 1Us (derived from 1L+ non-switched)	
2	Input signal DI ₀ : Connector X1 Input signal DI ₁ : Connector X2 Input signal DI ₂ : Connector X3 Input signal DI ₃ : Connector X4	
3	Sensor supply ground 1M	
4	IO-Link Master Port 1 (C/Q): Connector X1 Port 2 (C/Q): Connector X2 Port 3 (C/Q): Connector X3 Port 4 (C/Q): Connector X4	
5	Not used	

Table 3- 13 Pin assignment for digital inputs

Pin	Assignment of X5 and X6	View of the cable connector (wiring side)
1	24 V sensor supply 1Us (derived from 1L+ non-switched)	
2	Input signal DI ₅ : Connector X5 Input signal DI ₇ : Connector X6	
3	Sensor supply ground 1M	
4	Input signal DI ₄ : Connector X5 Input signal DI ₆ : Connector X6	
5	Functional earth FE	

3.6 Pin assignment of connectors

Table 3- 14 Pin assignment for digital outputs

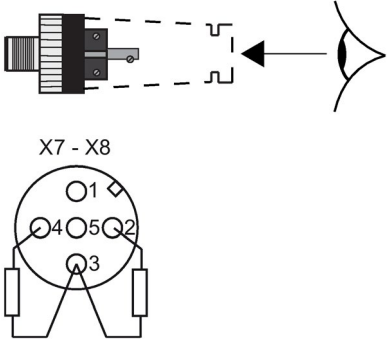
Pin	Assignment X7 and X8 (2L+ switched)	View of the cable connector (wiring side)
1	Not used	 <p>X7 - X8</p>
2	Output signal DQ ₁ : Connector X7 Output signal DQ ₃ : Connector X8	
3	Supply ground 2M	
4	Output signal DQ ₀ : Connector X7 Output signal DQ ₂ : Connector X8	
5	Functional earth FE	

IO-Link Master 4 IO-L 4×M12 (6ES7148-6JD00-0AB0)

The following tables contain the pin assignments for the IO-Link Master 4 IO-L 4×M12.

Table 3- 15 Pin assignment for IO-Link Master

Pin	Assignment of X1 to X4	View of the cable connector (wiring side)
1	24 V sensor supply 1Us (derived from 1L+ non-switched)	<p>Port Class A (type A)*</p> <p>X1 - X4</p> <p>IO-Link Device</p> <p>Port Class B (type B)</p> <p>X1 - X4</p> <p>IO-Link Device</p>
2	24 V actuator supply 2Ua	
3	Sensor supply ground 1M	
4	IO-Link master Port 1 (C/Q): Connector X1 Port 2 (C/Q): Connector X2 Port 3 (C/Q): Connector X3 Port 4 (C/Q): Connector X4	
5	Actuator supply ground 2M	

* If you use the sockets for IO-Link devices with Port Class A, do not place any signals on pins 2 and 5.

The M12 connectors are designed as Port Class B according to IO-Link specification. Pins 2 and 5 contain an additional power supply.

A non-interacting connection of devices of various port types (class A and class B) is possible using a 3-wire connecting cable (assignment of pins 1, 3 and 4).

NOTICE
24 V encoder supply 1Us
Only use the 24 V encoder supply 1Us supplied by the IO-Link master to supply the devices.

3.6.7 Pin assignment for analog inputs

I/O device 8 AI 4 U/I + 4 RTD/TC 8×M12 (6ES7144-6KD00-0AB0)

You will find the pin assignment for the 8 AI 4 U/I + 4 RTD/TC 8×M12 I/O device in the table below.

Table 3- 16 Pin assignment for voltage and current for the 8 AI 4 U/I + 4 RTD/TC 8×M12 I/O device



Pin	Assignment of X1, X3, X5, X7	View of the cable connector (wiring side)
1	24 V sensor supply 1Us (derived from 1L+ non-switched)	<p>Voltage</p> <p>X1, X3, X5, X7</p> <p>Current 4-wire transducer</p> <p>X1, X3, X5, X7</p> <p>2-wire transducer</p> <p>X1, X3, X5, X7</p>
2	Connector X1: Input signal M ₀₊ Connector X3: Input signal M ₁₊ Connector X5: Input signal M ₂₊ Connector X7: Input signal M ₃₊	
3	Sensor supply ground 1M	
4	Connector X1: Input signal M ₀₋ Connector X3: Input signal M ₁₋ Connector X5: Input signal M ₂₋ Connector X7: Input signal M ₃₋	
5	Functional earth FE	
		<p>① 4- or 5-core shielded copper cable</p> <p>② 3-, 4-, or 5-core shielded copper cable</p>

Table 3- 17 Pin assignment for RTD for the 8 AI 4 U/I + 4 RTD/TC 8×M12 I/O device

Pin	Assignment of X2, X4, X6, X8 (for RTD)	View of the cable connector (wiring side)
	Connector X2: Input signal 4 Connector X4: Input signal 5 Connector X6: Input signal 6 Connector X8: Input signal 7	
4-conductor		<p>X2, X4, X6, X8 ①</p>
1	Constant current line positive I_{Cn+}	
2	Measurement cable positive M_{n+}	
3	Constant current line negative I_{Cn-}	
4	Measurement cable negative M_{n-}	
5	Functional earth FE	
3-conductor		<p>X2, X4, X6, X8 ②</p>
1	Constant current line positive I_{Cn+}	
2	Measurement cable positive M_{n+}	
3	Measurement cable negative M_{n-} and constant current line negative I_{Cn-}	
5	Functional earth FE	
2-conductor		<p>X2, X4, X6, X8 ②</p>
1	Measurement cable positive M_{n+} and constant current line positive I_{Cn+}	
3	Measurement cable negative M_{n-} and constant current line negative I_{Cn-}	
5	Functional earth FE	
① 4- or 5-core shielded copper cable		
② 3-, 4-, or 5-core shielded copper cable		

3.6 Pin assignment of connectors

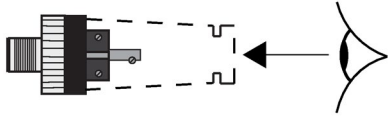
Table 3- 18 Pin assignment for thermocouple for the 8 AI 4 U/I + 4 RTD/TC 8×M12 I/O device

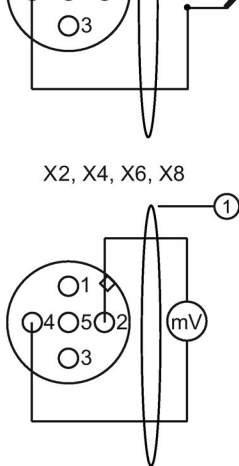
Pin	Assignment X2, X4, X6, X8 (for thermocouples and ±80 mV)	View of the cable connector (wiring side)
1	Not used	
2	Connector X2: Input signal M ₄ + Connector X4: Input signal M ₅ + Connector X6: Input signal M ₆ + Connector X8: Input signal M ₇ +	 <p>X2, X4, X6, X8</p>
3	Not used	
4	Connector X2: Input signal M ₄ - Connector X4: Input signal M ₅ - Connector X6: Input signal M ₆ - Connector X8: Input signal M ₇ -	 <p>X2, X4, X6, X8</p>
5	Functional earth FE	 <p>X2, X4, X6, X8</p>
① 3-, 4-, or 5-core shielded copper cable		

I/O device 8 AI RTD/TC 8×M12 (6ES7144-6KD50-0AB0)



You will find the pin assignment for the 8 AI RTD/TC 8×M12 I/O device in the table below.

Table 3- 19 Pin assignment for RTD for the 8 AI RTD/TC 8×M12 I/O device

Pin	Assignment X1 to X8 (for RTD)	View of the cable connector (wiring side)
	Connector X1: Input signal 0 Connector X2: Input signal 4 Connector X3: Input signal 1 Connector X4: Input signal 6 Connector X5: Input signal 2 Connector X7: Input signal 6 Connector X7: Input signal 3 Connector X8: Input signal 7	
4-conductor		
1	Constant current line positive I_{Cn+}	
2	Measurement cable positive M_n+	
3	Constant current line negative I_{Cn-}	
4	Measurement cable negative M_n-	
5	Functional earth FE	
3-conductor		
1	Constant current line positive I_{Cn+}	
2	Measurement cable positive M_n+	
3	Measurement cable negative M_n- and constant current line negative I_{Cn-}	
5	Functional earth FE	
2-conductor		
1	Measurement cable positive M_n+ and constant current line positive I_{Cn+}	
3	Measurement cable negative M_n- and constant current line negative I_{Cn-}	
5	Functional earth FE	
① 4- or 5-core shielded copper cable ② 3-, 4-, or 5-core shielded copper cable		

3.6 Pin assignment of connectors

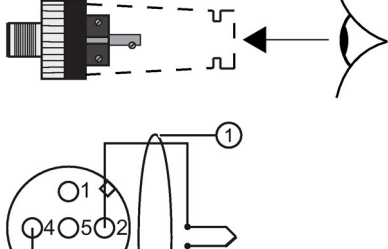
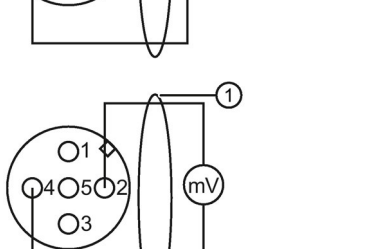
Table 3- 20 Pin assignment for thermocouple for the 8 AI RTD/TC 8×M12 I/O device

Pin	Assignment of X1 to X8 (for thermocouples and ±80 mV)	View of the cable connector (wiring side)
1	Not used	
2	Connector X1: Input signal M ₀ + Connector X2: Input signal M ₄ + Connector X3: Input signal M ₁ + Connector X4: Input signal M ₅ + Connector X5: Input signal M ₂ + Connector X6: Input signal M ₆ + Connector X7: Input signal M ₃ + Connector X8: Input signal M ₇ +	
3	Not used	
4	Connector X1: Input signal M ₀ - Connector X2: Input signal M ₄ - Connector X3: Input signal M ₁ - Connector X4: Input signal M ₅ - Connector X5: Input signal M ₂ - Connector X6: Input signal M ₆ - Connector X7: Input signal M ₃ - Connector X8: Input signal M ₇ -	
5	Functional earth FE	
① 3-, 4-, or 5-core shielded copper cable		

3.6.8 Pin assignment M12 compensation connector for thermocouples

M12 compensation connectors (6ES7194-4AB00-0AA0)

You will find the pin assignment for the M12 compensation connector in the table below.

Table 3- 21 Pin assignment of the M12 compensation connector

Pin	Assignment X1	View of the M12 compensation connector
1	Measurement cable 1M+ assigned with internal Pt1000	
2	Input signal M_0+	
3	Measurement cable 1M- assigned with internal Pt1000	
4	Input signal M_0-	
5	Functional earth FE	
① Cable with cores made of thermocouple materials ② Integrated resistance thermometer Pt1000 ③ M12 compensation connector		

See also

Installing (Page 20)

3.6.9 Pin assignment for analog output

I/O device 4 AO U/I 4×M12 (6ES7145-6HD00-0AB0)

You will find the pin assignment for the 4 AO U/I 4×M12 I/O device in the table below.

Table 3- 22 Pin assignment for voltage and current for the 4 AO U/I 4×M12 I/O device

Pin	Assignment of X1 to X4	View of the cable connector (wiring side)
1	24 V actuator supply 1U _A (derived from 1L+ non-switched)	<p>X1 - X4</p>
2	Output signal Q ₀₊ : Connector X1 Output signal Q ₁₊ : Connector X2 Output signal Q ₂₊ : Connector X3 Output signal Q ₃₊ : Connector X4	
3	Actuator supply ground 1M	
4	Output signal Q ₀₋ : Connector X1 Output signal Q ₁₋ : Connector X2 Output signal Q ₂₋ : Connector X3 Output signal Q ₃₋ : Connector X4	
5	Functional earth FE	
<p>① 3-, 4-, or 5-core shielded copper cable</p>		

3.7 Wiring the terminal block

Tools required

You need a medium-sized cross-tip screwdriver to screw on the terminal block and a slotted screwdriver to press down the insulation displacement terminals.

Wiring the connectors

You do not have to strip the cables. They are striped automatically when you press down the insulation displacement terminals.

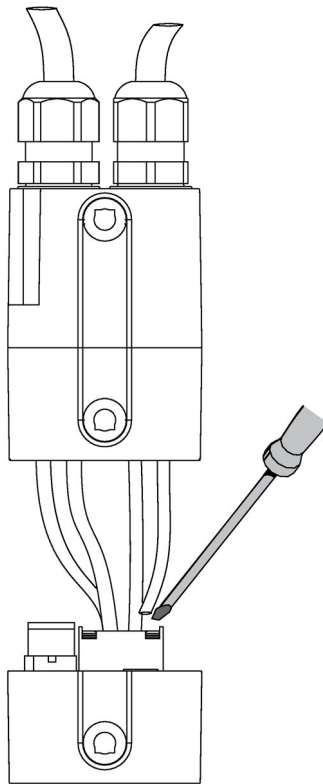

Figure 3-4 Wiring the terminal block

3.7 Wiring the terminal block

We'll show you an example of the separate installation of the terminal block and how to wire it to several I/O devices.

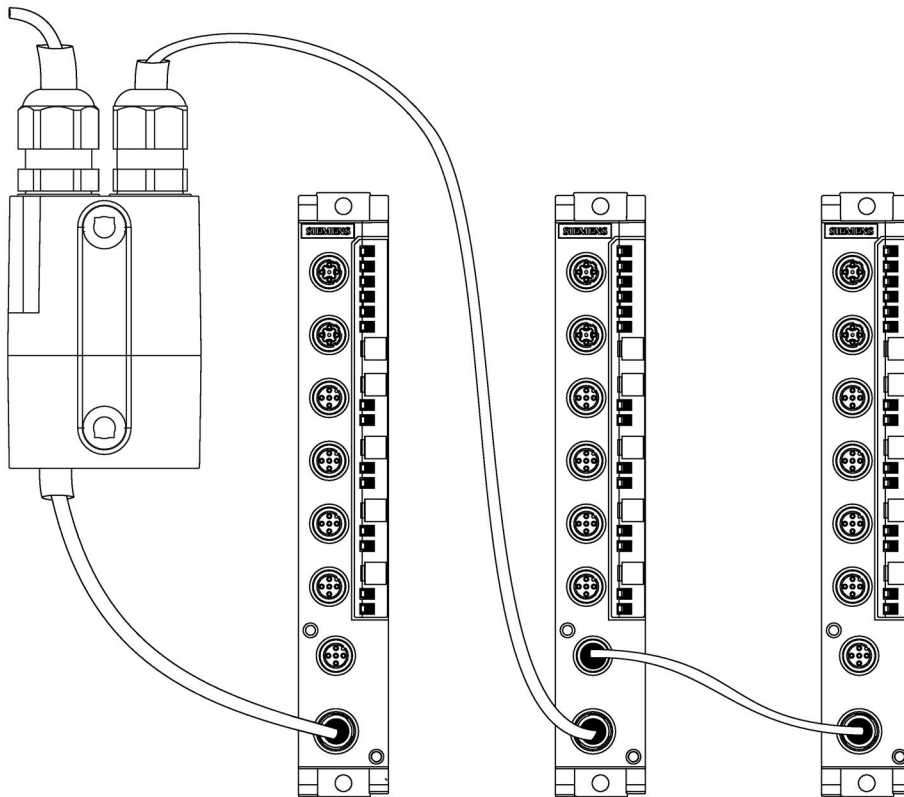

Figure 3-5 Wiring of the terminal block and of several I/O devices

You can tap a maximum load of 4 A from each supply voltage of the I/O device. You can loop-through the rest.

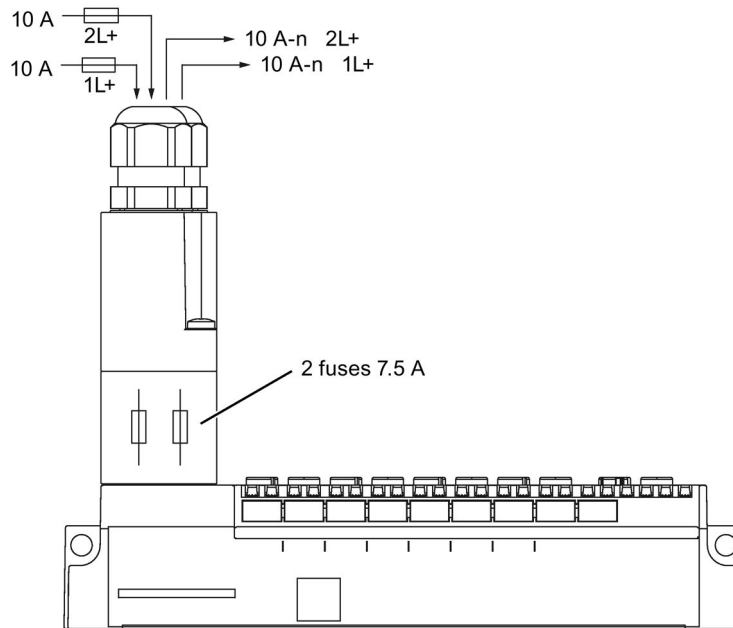

Figure 3-6 Principle of current distribution at the terminal block

Pin assignment

The tables below show the pin assignments.

Table 3- 23 Pin assignment of the insulation displacement terminal block.

Pin	Assignment	View of the insulation displacement terminal block:
1	24 V (1L+ non-switched)	
2	Ground 1M (non-switched)	
3	24 V (2L+ switched)	
4	Ground 2M (switched)	

Table 3- 24 Pin assignment of the M12 connector

Pin	Assignment	View of the cable connector
1	24 V (1L+ non-switched)	
2	Ground 2M (switched)	
3	Ground 1M (non-switched)	
4	24 V (2L+ switched)	

Information on wiring

- If you are wiring your configuration, you must take into account the impact of cable length on the supply voltage to the ET 200eco PN (permitted tolerance).
- The maximum infeed current of the terminal block is 10 A for 1L+ non-switched and 10 A for 2L+ switched.

Do not exceed these values.

<p>! CAUTION</p> <p>If you do not adhere to the maximum infeed currents and the cable cross-sections required for these currents, you will risk overheating the cable insulation and contacts resulting in damage to the device.</p>

See also

Installing the terminal block (Page 25)

3.8 Wiring the voltage distributor

Wiring the connectors

We use an example to show the configuration of the PD DC 24V 1×7/8" 4×M12 voltage distributor with connected I/O devices.

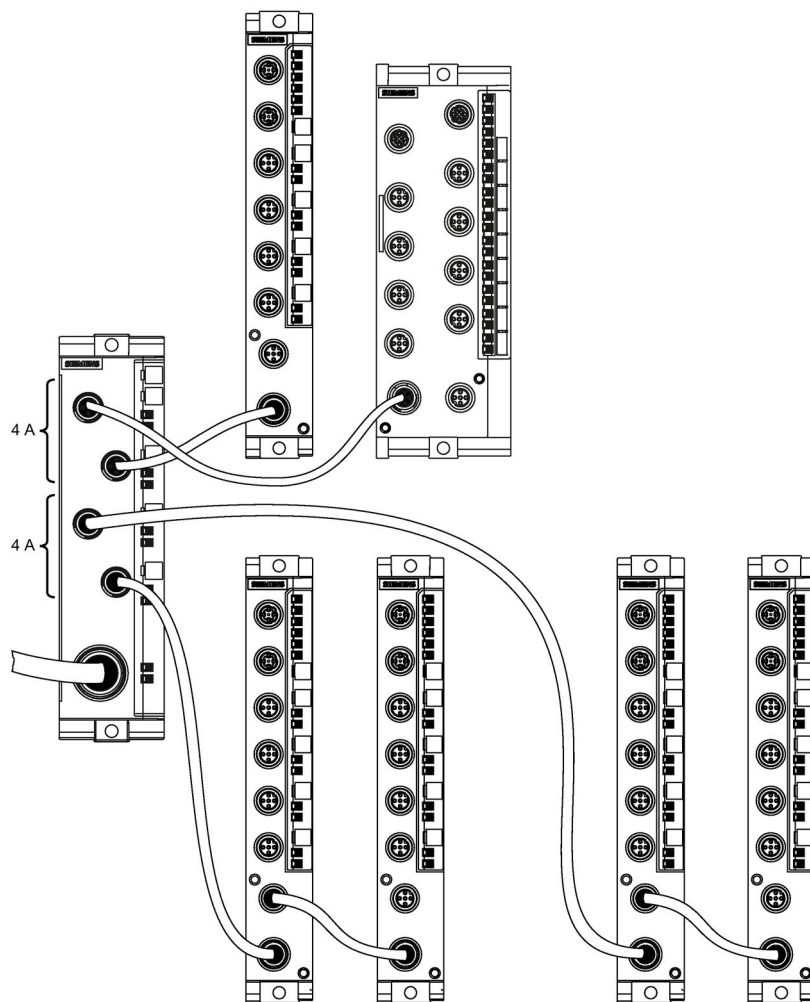

Figure 3-7 Wiring the voltage distributor

Pin assignment

The tables below show the pin assignments.

Table 3- 25 Pin assignment of the 7/8" connector at the current input of the voltage distributor

Pin	Assignment of X05	View of the 7/8" cable connector (24 V connection)
1	Ground 2M (switched)	 <p>X05</p>
2	Ground 1M (non-switched)	
3	Functional earth FE	
4	24 V (1L+ non-switched)	
5	24 V (2L+ switched)	

Table 3- 26 Pin assignment of the M12 cable connector at the current output

Pin	Assignment of X01 to X04	View of the M12 cable connector
1	24 V (1L+ non-switched)	 <p>X01 - X04</p>
2	Ground 2M (switched)	
3	Ground 1M (non-switched)	
4	24 V (2L+ switched)	
5	Not used	

Information on wiring

- If you are wiring your configuration, you must take into account the impact of cable length on the supply voltage to the ET 200eco PN (permitted tolerance).
- The maximum input current of the voltage distributor is 8 A for 1L+ non-switched and 2L+ switched.

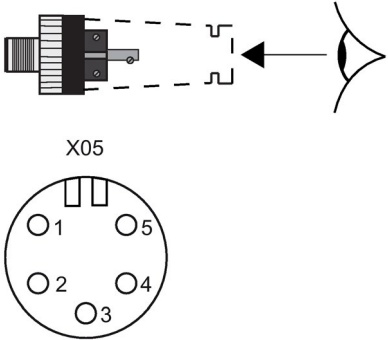
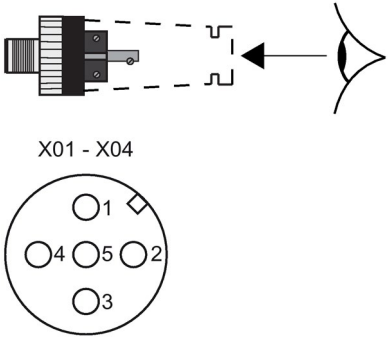
Do not exceed these values.

 **CAUTION**

If you do not adhere to the maximum infeed currents and the cable cross-sections required for these currents, you will risk overheating the cable insulation and contacts resulting in damage to the device.

3.9 Looping PROFINET and the supply voltage

Properties

The I/O device is equipped with one connector for the infeed and one socket for loop-through of the supply voltage. The connector for infeed and the socket for loop-through are interconnected internally.

The I/O device is equipped with two sockets for PROFINET IO. One socket is available for the infeed and one socket for loop-through of the PROFINET IO.

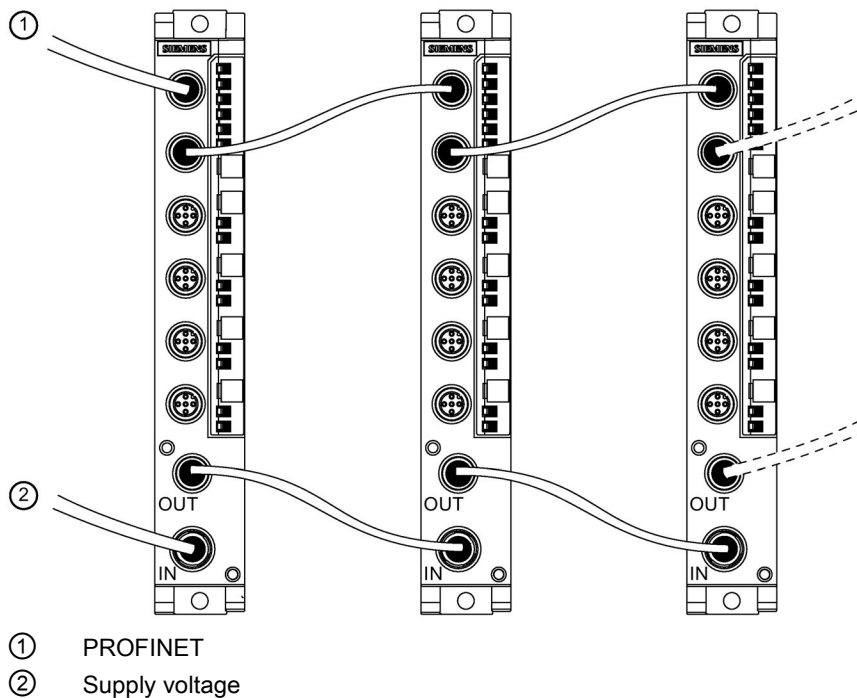

Figure 3-8 PROFINET and supply voltage loop-through for ET 200eco PN

Information on wiring

- If you are wiring your configuration, then you must take into account the impact of cable length on the supply voltage to the ET 200eco PN (permissible tolerance).
- The maximum infeed current of the I/O device is 4 A for 1L+ non-switched and 4 A for 2L+ switched.

Those values must not be exceeded.

⚠ CAUTION

If you do not adhere to the maximum infeed currents and the cable cross-sections required for these currents, you will risk overheating the cable insulation and contacts, and damage to the device.

Configuring

4.1 Configuring ET 200eco PN

Requirements

You need STEP 7 as of version V5.4, SP4 and possibly HSP.

Introduction

ET 200eco PN is included in the hardware catalog of *HW Config* after the start of STEP 7.

Procedure

1. Start SIMATIC Manager.
2. Create a new project.
3. Configure the ET 200eco PN with *HW Config*.
4. Double-click on the technology module at slot 1 of the ET 200eco PN in the configuration table and set the parameters.
5. Save the configuration, or download it to the IO Controller.

Prerequisite for the GSD file

You will need a GSD file, available for download from the Internet (<http://support.automation.siemens.com/WW/view/en/19698639/133100>).

ET 200eco PN family:
gsdml-v2.2-siemens-et200eco"date format yyyyymmdd".xml

Configuring ET 200eco PN on PROFINET IO using STEP 7

1. Start STEP 7 and call up the **Options > Install New GSD File** menu command in *HW Config*.
2. In the next dialog box, select the GSD file to install, and confirm with "OK". Result: ET 200eco PN is displayed in the hardware catalog, PROFINET IO folder.
3. The rest of the procedure is as described in the Programming with STEP 7 (<http://support.automation.siemens.com/WW/view/en/18652056>) manual.

See also

For further information, refer to the STEP 7 online help.

4.2 Configuring an IO-Link master

4.2.1 Configuring the IO-Link Master 6ES7148-6JA00-0AB0

Requirements

Configuration of the IO-Link Master takes place in two steps:

1. You need STEP 7 as of version V5.4 + SP5 + HSP188 for the IO-Link Master.
2. Configure the connected IO-Link Devices, encoders, and actuators with the Port Configurator tool (S7-PCT).

Configuring the IO-Link Master with HW Config

1. Start the SIMATIC Manager and configure the project as described in the STEP 7 online help.
2. Drag the IO-Link Master from the HW catalog **PROFINET IO > ET 200eco PN > IO Link > 4 IO-L + 8 DI + 4 DO DC24V/1.3A 8×M12 V6.1**.

You can freely choose the address space in the **Properties > Addresses** field for each slot of the IO-Link Master. Additional information on possible configurations is available in the chapter I/O address space (Page 250).

3. Assign the IO-Link Master parameters. You can assign the parameters separately for a functional unit:
 - The PROFINET IO parameters are accessed by double-clicking Slot 0.
 - The IO-Link parameters are accessed by double-clicking Slot 1.
 - The 8 digital input and 4 digital output parameters are accessed by double-clicking Slot 2.

Configuring the IO-Link Devices using "Configure IO-Link"

1. Select Slot 1 "4 IO-L" from the configuration table of the I/O device IO-Link Master.
2. Right-click and select "Configure IO-Link" in the following shortcut menu.
Result: S7-PCT is started.
3. Now start with the parameter assignment of the IO-Link Devices, sensors, and actuators. You can find additional information in the S7-PCT online help.

Configuring the IO-Link Master with GSD file

1. Install the GSD file in HW Config. The GSD file is available on the Internet (<https://support.industry.siemens.com/cs/ww/en/view/33291771>).
2. Select the IO-Link Master I/O device in the hardware catalog of HW Config.
3. You can freely choose the address space in the **Properties > Addresses** field for each slot of the IO-Link Master. In contrast to HSP configuration, the address space on Slot 1 "4 IO-L" is set permanently to 32 byte inputs and outputs. Additional information on possible configurations is available in the chapter I/O address space (Page 250).
4. Assign the IO-Link Master parameters. You can assign the parameters separately for each functional unit:
 - The PROFINET IO parameters are accessed by double-clicking Slot 0.
 - The IO-Link parameters are accessed by double-clicking Slot 1.
 - The 8 digital input and 4 digital output parameters are accessed by double-clicking Slot 2.

Configuring the IO-Link device via S7-PCT

1. Select Slot 1 "4 IO-L" from the configuration table of the I/O device IO-Link Master.
2. Right-click and select "Start Device Tool" in the following shortcut menu.
Result: S7-PCT is started.
3. Now start with the parameter assignment of the IO-Link Devices, sensors, and actuators.
You can find additional information in the S7-PCT online help.

Response of the IO-Link Master in unparameterized state and after "Resetting the IO-Link settings" via S7-PCT

- All ports of the IO-Link Master are deactivated.
- All user data are equal to 0.
- All bits of the value status are set to "invalid."
- The maintenance data 1 to 3 are deleted.

4.2.2 Configuring the IO-Link Master 6ES7148-6JD00-0AB0

Introduction

The IO-Link Master 6ES7148-6JD00-0AB0 is configured and parameters are assigned in the user interface of the selected configuration software.

"**Configuring**" is understood to mean arranging, setting and networking of devices and modules.

"**Assigning parameters**" is understood to mean setting the properties of the components used. The parameters of the hardware and the settings for the data exchange are assigned in the process.

Configuring the submodule of the IO-Link master

Requirements

- You have configured your automation system.
- In the device configuration of the 6ES7148-6JD00-0AB0 IO-Link Master, you have selected the IO-Link port that you want to configure.

Procedure

1. You configure the operating mode of the submodule. An overview of possible operating modes is available in the chapter Configuration (Page 222).
2. When you have configured the submodule and thus defined the operating mode, make the additional settings:
 - Enable the Autostart parameter (without S7-PCT)

Note

Changes to the port configuration

If you have assigned the parameters for the IO-Link device via Autostart (without S7-PCT), or have configured the port as digital input, digital output or disabled, you can no longer change the port configuration via S7-PCT.

- Enabling the diagnostics (only in IO-Link mode)
- Enable the parameter assignment for the hardware interrupts (only in IO-Link mode)

Response after "Resetting the IO-Link settings" via S7-PCT

- Deleting the IO-Link device data in the backup memory or the IO-Link Master
- Resetting the parameters to factory state:
 - Resetting the inspection severity and the backup behavior

Note

Effects on the device configuration

If you have reset the IO-Link settings via S7-PCT, you have to reload the device configuration via S7-PCT.

4.3 Device names for ET 200eco PN

Introduction

Every PROFINET IO device is assigned a unique device ID (MAC address) before it leaves the factory.

Each ET 200eco PN IO Device is addressed based on its device name during configuration and in the user program.

You will find detailed information on addressing in PROFINET IO in the the SIMATIC PROFINET system description

(<http://support.automation.siemens.com/WW/view/en/19292127>) System Manual.

Requirements

- An online PROFINET connection from the programming device to the IO Device is required for assigning the device name to the IO Device.
- The IO device is configured and an IP address assigned in *HW Config*.

Assigning device names

1. Switch on the supply voltages for the ET 200eco PN.
2. Open the "Properties - ET 200eco PN" window in *HW Config*. Enter the device name for the IO Device and confirm your entry with "OK".
3. Select **PLC > Ethernet > Assign Device Name** in *HW Config*.
4. Click on "Assign Name" in the "Assign Device Name" window.

Result

The device name is saved internally in the ET 200eco PN.

Node flash test

The "Assign device name" dialog box displays all IO Devices used. Compare the MAC address of the device with the MAC address displayed and then select the correct IO Device.

The identification of IO Devices in a plant is facilitated by a node flash test. The flash test is activated as follows:

1. Select one of the displayed IO Devices from the "Assign device name" dialog box.
2. Select the flashing period.
3. Click the "Flash on" button.

The LINK LEDs flash on the selected IO Device.

Detailed information

For additional information, refer to the *STEP 7* Online Help and the SIMATIC PROFINET system description (<http://support.automation.siemens.com/WW/view/en/19292127>) System Manual.

4.4 Ports of ET 200eco PN

Introduction

The ET 200eco PN can diagnose 2 ports: X01 P1 and X01 P2.

Requirements

- The ports must have been configured in *HW Config*.
- Port diagnostics must have been enabled.

Configuring the ports in *HW Config*

Configure both ports in the "Properties of ET 200eco PN" dialog box of HW Config:

- "Addresses" tab: Diagnostic address of the relevant port.
- "Topology" tab:
- "Options" tab:

To enable port diagnostics, select the following "Connection" setting at "Transmission Medium/Duplex": "Automatic Settings (monitor)".

See also

See the *STEP 7* Online Help.

4.5 Isochronous real-time communication

Isochronous real-time communication

Synchronized communication protocol for cyclic exchange of IRT data between PROFINET devices. A reserved bandwidth is available within the send cycle for IRT IO data. The reserved bandwidth ensures that the IRT data are transmitted at reserved, synchronized intervals while remaining uninfluenced by another greater network load (for example, TCP/IP communication or additional realtime communication).

- "High performance" IRT option (not for 6ES7148-6JA00-0AB0 IO-Link Master):

Topological configuration is required (STEP 7 V5.5 or higher).

Note

When using the IO controller as a Sync-Master for IRT communication with the "high performance" IRT option, the following must be observed:

Operate the IO controller as a Sync-Master if you configure the IRT communication with the "high performance" option.

Otherwise, IRT and RT configured IO devices may fail if the sync master fails.

Note

Using redundant Sync-Master

When using redundant Sync-Masters, a short-term failure of the 6ES7148-6JD00-0AB0 IO-Link Master can occur during the switching of the Sync-Master.

Detailed information

For additional information, refer to the SIMATIC PROFINET system description (<http://support.automation.siemens.com/WW/view/en/19292127>) System Manual and the Migration from PROFIBUS DP to PROFINET IO (<http://support.automation.siemens.com/WW/view/en/19289930>) Programming Manual.

4.6 Prioritized startup

Prioritized startup

Prioritized startup denotes PROFINET functionality for accelerating the startup of IO Devices for RT and IRT communication within a PROFINET IO system.

The function reduces the time that the correspondingly configured IO Devices require to recover the cyclic exchange of user data in the following situations:

- After power has returned
- After station recovery
- After activation of IO Devices

Detailed information

For further information, see the SIMATIC PROFINET system description (<http://support.automation.siemens.com/WW/view/en/19292127>) System Manual and the Migration from PROFIBUS DP to PROFINET IO (<http://support.automation.siemens.com/WW/view/en/19289930>) Programming Manual.

4.7 Device replacement without programming device

Device replacement without programming device

IO Devices having this function can be replaced easily:

- The device name does not have to be assigned using the programming device.

Instead of the programming device, the IO Controller now assigns the device name to the replacement IO Device. The IO Controller uses the configured topology and the correlations derived from the IO Devices. The configured target topology must agree with the actual topology.

IO Devices that have already been in operation must be reset to factory settings before being put back into operation.

Detailed information

For further information, see the SIMATIC PROFINET system description (<http://support.automation.siemens.com/WW/view/en/19292127>) System Manual and the Migration from PROFIBUS DP to PROFINET IO (<http://support.automation.siemens.com/WW/view/en/19289930>) Programming Manual.

4.8 Media redundancy

Media redundancy

Function for ensuring the network and system availability. Redundant transmission links (ring topology) ensures that an alternative communication path is made available if a transmission link fails (starting with STEP 7 V5.5) (not for 6ES7148-6JA00-0AB0 IO-Link Master up to firmware version 6.x).

For additional information, refer to the STEP 7 online help and the SIMATIC PROFINET system description (<http://support.automation.siemens.com/WW/view/en/19292127>) manual.

4.9 Reset to factory settings (PROFINET)

Reset to factory settings (PROFINET)

Note

The stations of a bus segment can fail during the reset to factory settings.

"Reset to factory settings" is only possible if the IO Device is not exchanging data with a controller.

SNMP parameters in non-volatile memory are reset to factory settings (*STEP 7* V5.3 SP 3 and higher) in the *HW Config* dialog **PLC > Ethernet > Edit Ethernet Nodes**, "Reset" button under "Reset to factory settings".

The following retentive data are retained during the reset:

- The MAC address,

Note

Deleting the device name

The device name is deleted by means of the "Reset to factory settings" function.

- The I&M0 data,
- The settings configured with S7-PCT,
- The outputs take up the configured substitute value behavior.

4.10 SNMP

SNMP

The interface module supports the SNMP Ethernet service. MIB-2 (RFC1213) is supported. R/W objects can be edited using SNMP tools and are saved to module memory.

Following replacement with a brand new module, the R/W objects of the interface module are set to factory settings.

See also

SIMATIC PROFINET system description
(<http://support.automation.siemens.com/WW/view/en/19292127>)

Commissioning

5.1 Commissioning ET 200eco PN

Introduction

Your automation system is commissioned depending on the current plant configuration. The section below describes the procedure for commissioning the ET 200eco PN on an IO Controller.

Requirements for commissioning the ET 200eco PN on the PROFINET IO

Actions	Reference
ET 200eco PN installed	Chapter Installing (Page 20)
ET 200eco PN wired	Chapter Wiring (Page 29)
The IO Device was assigned a device name	Chapter Configuring (Page 67)
ET 200eco PN configured	Chapter Configuring (Page 67)
Supply voltage for the IO Controller is switched on	IO Controller manual
IO Controller switched to RUN	IO Controller manual

Commissioning ET 200eco PN

1. Switch on the voltage supply 1L+ non-switched for the ET 200eco PN.
2. Switch on the supply voltage(s) 2L+ switched as required.

Startup of the ET 200eco PN on the PROFINET IO

The schematic diagram below illustrates the startup of the ET 200eco PN on the PROFINET IO:

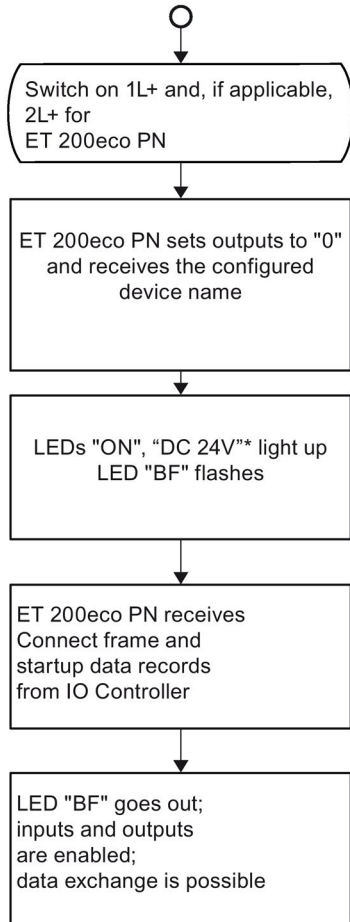

* "DC 24V" only for digital output and if 2L+ is connected

Figure 5-1 Startup of the ET 200eco PN on the PROFINET IO

Maintenance

6.1 Replacing the fuse

Introduction

The terminal block is equipped with replaceable fuses.
The figure below shows the fuses in the terminal block.

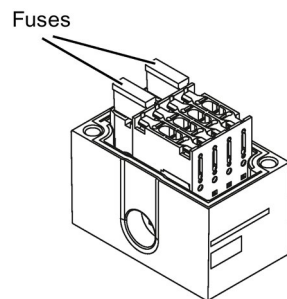

Figure 6-1 Fuses in the terminal block

Requirements

Switch off the supply voltage before you replace any fuses. Result: CPU stop of the ET 200eco PN.

Replacing a fuse of the terminal block

1. Remove the screws from the front panel of the terminal block using a crosstip screwdriver.
2. Remove the top section.
3. Remove the faulty fuse.
4. Press the new fuse (miniature copper flat fuse, type FK1, 7.5 A, fast-blow) into the fuse holder. The fuse is available as accessory.
5. Connect the terminal block and tighten the screws.
6. Switch on the supply voltage again.

6.2 Online firmware update by means of STEP 7 Manager

Introduction

To update the firmware of the ET 200eco PN including its I/O devices, you require the *.UPD files containing the current firmware version.

Requirements

- An online firmware update can be performed as of STEP 7 V5.4 + SP2.
- The I/O device of the station whose firmware is to be updated must be accessible online. The network card used must be set to "TCP/IP (Auto)" in the SIMATIC Manager under **Options > Set PG/PC Interface**.
- The files containing the current firmware versions must be available in the file system of your programming device or PC. A folder must contain the files of one firmware version only.

Note

The I/O device must be reset to the factory setting before the firmware update is carried out when special port parameter assignments have been carried out.

Performing a firmware update

1. Start STEP 7.
2. In the SIMATIC Manager select **PLC > Available stations**.
3. Select the I/O device.
4. Select the menu command **PLC > Update Firmware**. I/O devices without NameOfStation (NoS) are displayed with their MAC address.

As of STEP 7 V5.4 SP5, Slot 0 must also be specified for the I/O devices. In previous versions of STEP 7 this setting is specified implicitly.

With the ET 200eco PN, you can use the IO-Link Master 6ES7148-6JA00-0AB0 to perform the update of functional units:

- Slot 0: PROFINET functional unit
 - Slot 1: IO-Link functional unit
 - Slot 2: 8 DI + 4 DQ functional unit
5. In the **Update Firmware** dialog, select the path to the firmware update files (*.UPD) using the "Browse" button.
 6. After you have selected a file, the information in the bottom boxes of the "Update Firmware" dialog box indicates the I/O device for which the file is suitable and from which firmware version.
If the firmware is to be loaded immediately after successful installation, select the check box "Activate firmware after download". If the check box is not selected, the firmware becomes active after the next Power Off/On.
 7. Click "Run". The I/O device then automatically updates the firmware.

Result

You have updated your ET 200eco PN device online with a new firmware version.

Starting with version V6.0.0, if the ET 200eco PN I/O device was reset to the factory settings before the firmware update, the port parameter assignments are transmitted and activated again as a result of the neighborhood detection after the first connection is established between the controller and the ET 200eco PN I/O device. In previous versions, the device name had to be reassigned by selecting **PLC > Edit Ethernet Nodes ...** .

Note

You can also update the firmware using *HW Config*. You can find additional information in the STEP 7 online help.

6.3 Acyclic data exchange with the IO-Link library

"IO_LINK_MASTER" and "IO_LINK_DEVICE" function blocks

The "IO_LINK_MASTER" and "IO_LINK_DEVICE" function blocks for controllers of the S7-300, S7-400, S7-1200 and S7-1500 families are available for acyclic data exchange.

The function blocks support the following tasks:

- Parameterization of an IO-Link device during operation
- Executing IO-Link port functions
- Diagnostics of IO-Link devices
- Backing up/restoring IO-Link device parameters

Note

"IO_LINK_MASTER" and "IO_LINK_DEVICE" function blocks

The "IO_LINK_MASTER" and "IO_LINK_DEVICE" function blocks replace the functions of the formerly available "IOL_CALL" block.

The "IO_LINK_MASTER" function block is used for all functions and access to the IO-Link master, the "IO_LINK_Device" for all access t the IO-Link device.

Make sure that the "IO_LINK_Device" function block is used only for the configured submodules with 6ES7148-6JD00-0AB0 IO-Link Master.

Reference

For an exact description of the procedure, refer to the IO-Link System functional manual on the Internet (<https://support.industry.siemens.com/cs/ww/en/view/65949252>).

The IO-Link block library is available for download on the Internet (<https://support.industry.siemens.com/cs/ww/en/view/82981502>).

You can find additional application examples for IO-Link block library on the Internet (<https://support.industry.siemens.com/cs/ww/en/view/90529409>).

6.4 Exchange object

Exchange object

With *HW Config*, the I/O devices are exchanged, for example, an 8-channel I/O device is replaced by a 16-channel I/O device. The following takes place:

With the "Exchange object" function, the device name, IP-address, etc. are taken over. The module/channel parameters are set to the "default" values.

Interrupt, error, and system messages

7.1 Interrupts of ET 200eco PN

Introduction

The IO Device generates interrupts as a reaction to specific error events. Interrupts are evaluated depending on the IO Controller used.

Evaluating interrupts using an IO Controller

The ET 200eco PN supports the following interrupts:

- Diagnostics interrupts
- Maintenance interrupts

In the event of an interrupt, interrupt OBs are executed automatically in the CPU of the IO Controller (refer to the System Software for S7-300/400 System and Standard Functions (<http://support.automation.siemens.com/WW/view/en/1214574>) Manual, chapter "Program design").

Information on the cause and class of the error is already available based on the OB number and start information.

You can obtain detailed information on the error event in the error OB by calling SFB 54 RALRM (read supplementary interrupt information).

Triggering diagnostics interrupts

After having detected an incoming or outgoing event (e.g., wire break), the device triggers a diagnostic interrupt for "Group diagnostics", if enabled, and for "Diagnostics for the relevant channel".

The CPU interrupts the processing of the user program and processes the diagnostics block OB 82. The event which led to the triggering of the interrupt is entered in the start information of OB 82.

7.2 Maintenance interrupts

Introduction

The PROFINET interfaces of the ET 200eco PN support the diagnostics concept and maintenance concept in PROFINET as defined in IEC 61158-6-10. The objective is early detection and elimination of potential disturbances.

Maintenance interrupts

The following maintenance interrupts are available for the ET 200eco PN:

- Sync mismatch (no synchronization)
- Jitter out of Boundary (jitter too high)
- Frame dropped (frames are discarded)
- I/O error (with IO-Link devices)

System alarms in *STEP 7*

The maintenance information is generated in *STEP 7* with the following system alarms:

- Maintenance required, identified by a yellow wrench icon at the relevant port.

See also

For additional information, refer to the SIMATIC PROFINET system description (<http://support.automation.siemens.com/WW/view/en/19292127>) System Manual and the Migration from PROFIBUS DP to PROFINET IO (<http://support.automation.siemens.com/WW/view/en/19289930>) Programming Manual.

7.3 Diagnostics by means of LED display

7.3.1 Diagnostics using the LED display on the I/O devices

LED display

The figure below shows the position and arrangement of the LED display on the ET 200eco PN I/O devices:

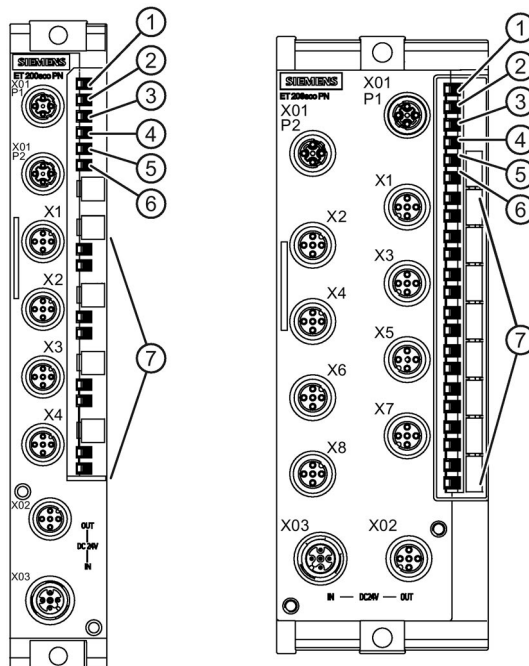

- ① SF/MT: (red/yellow LED)
- ② BF: Bus monitoring (red LED)
- ③ ON: Electronic/sensor/load supply 1L+ non-switched (green LED)
- ④ DC 24V: Load voltage supply 2L+ switched (green LED), only for digital output device
- ⑤ P1 LK: Port1 Link (green LED)
- ⑥ P2 LK: Port2 Link (green LED)
- ⑦ Channel status, channel fault (green/red LED)

Status and error displays SF/MT, BF, ON

Table 7- 1 Status and error displays of the ET 200eco PN

LEDs			Meaning	Remedy
SF/MT	BF	ON		
Off	Off	On	IO Device is currently exchanging data with the IO Controller without errors. The IO Device is supplied with power (electronic/sensor supply).	---
Off	Off	Off	Electronic/sensor voltage missing or too low at the I/O device.	Switch on the electronic/sensor/load supply for the IO Device.
			Hardware fault.	Replace the I/O device.
*	Flashing	On	Faulty or no connect message frame - no data exchange between the IO Controller and the distributed device (IO Device), although the device is physically connected to the switch. Causes: <ul style="list-style-type: none"> • Incorrect device name • Error in configuration • Parameterization errors 	<ul style="list-style-type: none"> • Check the I/O device. • Check the configuration and parameter settings. • Check the device name. • Check the IO Controller.
*	On	On	<ul style="list-style-type: none"> • The IO Device is not connected to a switch. 	<ul style="list-style-type: none"> • Connect to the IO Controller. • Assign a valid device name to the I/O device. • Check the bus installation. • Check whether the M12 cable connectors are properly installed. • Check whether the bus cable to the IO Controller is interrupted.
On (red)	*	On	Fault in peripheral circuit. Incoming diagnostics	Evaluate the diagnostics interrupt.
On (yellow)	*	*	Maintenance alarm	Analyze the maintenance alarm.
* irrelevant				

Status display of the port LEDs

Table 7- 2 Status display of the port LEDs

LED		Meaning	Remedy
P1 LK	P2 LK		
Off	Off	No connection to the switch/IO Controller.	Check the IE cable.
On	On	Connection to switch/IO Controller.	-

Status display DC 24V (only on I/O devices with digital outputs)

The DC 24V LED is lit in green color to indicate that you have connected the 2L+ switched load voltage supply. If the LED is not lit, check whether power is switched, or whether the fuse is okay.

7.3.2 Diagnostics using LED display on the IO-Link masters

LED display IO-Link Master 4 IO-L + 8 DI + 4 DO DC 24V/1,3A 8×M12 (6ES7148-6JA00-0AB0)

The figure below shows the position and arrangement of the LED display on the IO-Link Master 4 IO-L + 8 DI + 4 DO DC 24V/1,3A 8×M12.

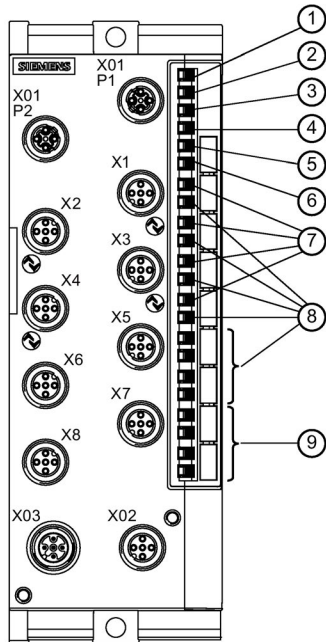

- ① SF/MT: (red/yellow LED)
- ② BF: Bus monitoring (red LED)
- ③ ON: Electronic/sensor/load supply 1L+ Non-Switched (green LED)
- ④ DC 24V: Load voltage supply 2L+ switched (green LED); digital output
- ⑤ P1 LK: Port1 Link (green LED)
- ⑥ P2 LK: Port2 Link (green LED)
- ⑦ IO-L: Status display / Communications OK (green LED)
- ⑧ Input: Channel status, channel fault (green/red LED)
- ⑨ Output: Channel status, channel fault (green/red LED)

Status display of the IO-L LEDs

The following table displays the possible status displays of the IO-L LEDs.

Table 7- 3 Status display of the IO-L LEDs

LED	Meaning
IO-L	
On	<ul style="list-style-type: none"> • DI/DQ operating mode: Status when input or output is activated • IO-Link operating mode: When communication is running.
flashes at 2 Hz	<ul style="list-style-type: none"> • during startup or continuously if no operational IO-Link device as found.

LED display IO-Link Master 4 IO-L 4×M12 (6ES7148-6JD00-0AB0)

The figure below shows the position and arrangement of the LED display on the IO-Link Master 4 IO-L 4×M12.

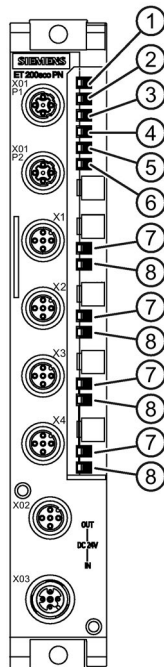

- ① SF/MT: (red/yellow LED)
- ② BF: Bus monitoring (red LED)
- ③ ON: Electronic/sensor/load supply 1L+ Non-Switched (green LED)
- ④ DC 24V: Load voltage supply 2L+ switched (green LED)
- ⑤ P1 LK: Port1 Link (green LED)
- ⑥ P2 LK: Port2 Link (green LED)
- ⑦ Q 1-4: Status indicator SIO mode (Green LED)
- ⑧ IO-L 1-4: Status display IO-Link communication / channel error (green/red LED)

LEDs Q1 to Q4

Valid for an IO-Link port that is in SIO mode.

Table 7- 4 Status displays of LEDs Q1 to Q4

LEDs			Meaning	Remedy
SF	Q1 to Q4	IO-L 1 to IO-L 4		
Off	On	Off	Input or output value is 1.	---
Off	Off	Off	Input or output value is 0 or port is deactivated.	---

LEDs IO-L 1 to IO-L 4

Valid for an IO-Link port that is in IO-Link mode.

Table 7- 5 Status displays of LEDs Q1 to Q4

LEDs			Meaning	Remedy
SF	Q1 to Q4	IO-L 1 to IO-L 4		
Off	Off	Flashes (green)	Flashes device	Check the IO-Link device used.
On	Off	Flashes (green)	No IO-Link communication (for example, when you have activated the port but no available IO-Link device can be found.)	Check the wiring.
Off	Off	On (green)	IO-Link communication established, no pending device error.	---
On	Off	On (red)	IO-Link communication established, pending device or channel error.	Check the IO-Link device used.
Off	Off	Off	Port deactivated	---

Reference

For status and error displays see section Diagnostics using the LED display on the I/O devices (Page 85).

7.3.3 Diagnostics using the LED display at the voltage distributor

LED display

The figure below shows the position and arrangement of the LED display on the voltage distributor.

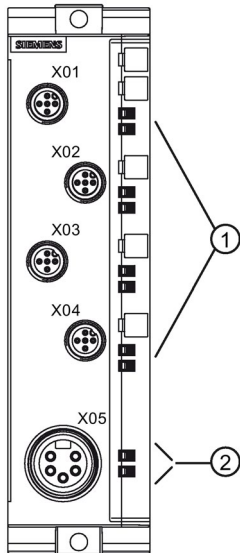

- ① Loop-through 1L/2L (green LED)
- ② Infeed voltage (green LED)

Figure 7-1 LED display at voltage distributor

Table 7- 6 Status displays on the voltage distributor

LED	Meaning
1L/2L	
Loop-through	
On	Voltage applied
Flashing	Overload
Off	Short-circuit
Infeed voltage	
On	Voltage applied
Off	Voltage not applied

7.4 Diagnostics messages of the I/O devices

Actions after a diagnostics message

Every diagnostics message triggers the following actions:

- The SF LED (red) of the I/O device lights up.
- Several simultaneous diagnostics messages are possible.
- Diagnostics data are reported as diagnostics interrupts and can be read from data records.
- Diagnostics messages are saved to the diagnostics buffer of the I/O controller.
- OB 82 is called. If there is no OB 82, the IO Controller goes to STOP.
- Acknowledgment of the diagnostics interrupt to enable new interrupts.

7.5 Diagnostics with STEP 7

7.5.1 Reading diagnostics data

Options for reading the diagnostics data

Table 7- 7 Reading diagnostics data in STEP 7

Automation system with IO Controller	Block or register in STEP 7	Application	See ...
SIMATIC S7	For example in <i>HW Config</i> by selecting Station > Open Online	Device diagnostics in plain text on the STEP 7 interface (in the Quick View, Diagnostics View or Module Status windows)	"Hardware diagnostics" in the STEP 7 online help
	SFB 52 "RDREC"	Reading data records from the IO Device	SFB, see STEP 7 online help (System functions/System function blocks)
	SFB 54 "RALRM"	Receiving interrupts from the IO Device	SFB, see STEP 7 online help (System functions/System function blocks)

7.5.2 Channel diagnostics

Additional information regarding the data records for PROFINET IO

For information on the structure of diagnostics data records, including programming examples, refer to the Migration from PROFIBUS DP to PROFINET IO (<http://support.automation.siemens.com/WW/view/en/19289930>) Programming Manual.

Structure of the manufacturer-specific diagnostics data records

The structure of the diagnostics data records is differentiated based on the BlockVersion. The following block versions apply to the ET 200eco PN:

ET 200eco PN	Article number	BlockVersion
8 DI DC 24V 4×M12	6ES7141-6BF00-0AB0	W#16#0101
8 DI DC 24V 8×M12	6ES7141-6BG00-0AB0	W#16#0101
16 DI DC 24V 8×M12	6ES7141-6BH00-0AB0	W#16#0101
8 DO DC 24V/1,3A 4×M12	6ES7142-6BF00-0AB0	W#16#0101
8 DO DC 24V/0,5A 4×M12	6ES7142-6BF50-0AB0	W#16#0101
8 DO DC 24V/1,3A 8×M12	6ES7142-6BG00-0AB0	W#16#0101
8 DO DC 24V/2,0A 8×M12	6ES7142-6BR00-0AB0	W#16#0101
16 DO DC 24V/1,3A 8×M12	6ES7142-6BH00-0AB0	W#16#0101
8 DIO DC 24V/1,3A 8×M12	6ES7147-6BG00-0AB0	W#16#0101
4 IO-L + 8 DI + 4 DO DC 24V/1,3A 8×M12	6ES7148-6JA00-0AB0	W#16#0101
4 IO-L 4×M12	6ES7148-6JD00-0AB0	W#16#0101
8 AI 4 U/I + 4 RTD/TC 8×M12	6ES7144-6KD00-0AB0	W#16#0101
8 AI RTD/TC 8×M12	6ES7144-6KD50-0AB0	W#16#0101
4 AO U/I 4×M12	6ES7145-6HD00-0AB0	W#16#0101

Manufacturer-specific diagnostics in the User Structure Identifier (USI)

- W#16#8000 channel diagnostics
- W#16#8002 extended channel diagnostics

7.5.3 Error classes for I/O devices

Error classes and remedies

The following tables show the error types for the I/O devices.

Error type for I/O devices, digital inputs/outputs, analog inputs/outputs

Table 7- 8 Overview Error types

Error class		Error text	Meaning	Remedy
00001 _B	1 _D	Short-circuit	<ul style="list-style-type: none"> Short-circuit to M at the sensor supply line Short-circuit at the output line Load impedance too low 	<ul style="list-style-type: none"> Correct the process wiring Check the sensor or actuator
00100 _B	4 _D	Thermal over-load	<ul style="list-style-type: none"> I/O device is overheating 	<ul style="list-style-type: none"> Check the process wiring Check the ambient temperature
00110 _B	6 _D	Wire break	<ul style="list-style-type: none"> Signal line to a sensor or actuator interrupted Sensor or actuator failure Load impedance too high 	<ul style="list-style-type: none"> Correct the process wiring Replace the sensor or actuator Use a sensor with lower impedance Use an actuator with lower load impedance
00111 _B	7 _D	Violation of upper limit	<ul style="list-style-type: none"> The value is above the overrange 	<ul style="list-style-type: none"> Correct the I/O device to sensor tuning Modify measuring range by means of parameter assignment
01000 _B	8 _D	Violation of lower limit	<ul style="list-style-type: none"> Value is below the underrange 	<ul style="list-style-type: none"> Correct the I/O device to sensor tuning Modify measuring range by means of parameter assignment
01001 _B	9 _D	Error	<ul style="list-style-type: none"> Internal I/O device error has occurred (diagnostic message on channel 0 applies to the whole I/O device). 	<ul style="list-style-type: none"> Replacement of I/O device
10000 _B	16 _D	Parameter assignment errors	<ul style="list-style-type: none"> I/O device is incorrectly parameterized 	<ul style="list-style-type: none"> Correct the parameter assignment
10001 _B	17 _D	1L+ or 2L+ is missing	<ul style="list-style-type: none"> Supply voltages missing or too low Load voltage supply missing or too low 	<ul style="list-style-type: none"> Check the supply voltages Check the load voltage supply Correct the process wiring
10101 _B	21 _D	Reference channel fault	<ul style="list-style-type: none"> Measurement cable for compensation interrupted Data record DS2 incorrect Timeout for "Dynamic ref. Temp." 	<ul style="list-style-type: none"> Correct the process wiring Check the data record DS2. Send DS2

Error classes for IO-Link Master (6ES7148-6JA00-0AB0), Slot 1

Table 7- 9 Overview Error types Slot 1

Error class		Error text	Meaning	IO-Link Master	IO-Link Device
00001 _B	1 _D	Short-circuit	Short circuit at the process cables of the IO-Link device (0x5151)		X
00010 _B	2 _D	Undervoltage	Supply voltage too low (0x5110 to 0x5119)		X
00100 _B	4 _D	Overload	Overload of the output stage of the IO-Link Devices (0x5410)		X
00101 _B	5 _D	Overtemperature	<ul style="list-style-type: none"> Ambient temperature too high (0x4110) IO-Link Device too hot (0x4210) IO temperature exceeded (0x4310) 		X
00110 _B	6 _D	Wire break	<ul style="list-style-type: none"> No IO-Link Device connected Incorrect IO-Link Device connected Signal cable to IO-Link Device interrupted Signal cable to IO-Link Device short-circuited Short-circuit of supply voltage at sensor IO-Link Device addressed with too short communication cycle time IO-Link Device cannot communicate due to another error (0xFF10) 	X	
00111 _B	7 _D	Overflow	<ul style="list-style-type: none"> Process variable range exceeded (0x8C10) Measuring range exceeded (0x8C20) 		X
01000 _B	8 _D	Underflow	Process variable range too small (0x8C30)		X
01001 _B	9 _D	Error	All the IO-Link error codes not listed here will be mapped to this PROFINET IO error.		X
			Hardware error at IO-Link Master detected	X	
10000 _B	16 _D	Parameter assignment errors	IO-Link Master could not be parameterized	X	
			Event code of the IO-Link Device (0x6230 to 0x6340)		X
10010 _B	18 _D	Fuse defective	Event code of the IO-Link Device (0x5450 to 0x5459)		X
11010 _B	26 _D	External error	IO-Link Device cannot be set to desired mode	X	

Errors types IO-Link Master (6ES7148-6JD00-0AB0)

IO-Link devices diagnostics

The IO-Link master generates PROFINET channel diagnostics (CET, ECET) from the IO-Link events of an IO-Link devices according to the following mapping rules:

The IO-Link event codes of the area 0x0000 – 0x7FFF_H are displayed directly in the "IO-Link Device Diagnostics - Page 1" (CET 0x9500_H):

$$ECET_H = IO\text{-Link Event Code}_H$$

The IO-Link event codes of the area 0x8000 – 0xFFFF_H are displayed directly in the "IO-Link Device Diagnostics - Page 2" (CET 0x9501_H) via the following rule:

$$ECET_H = (IO\text{-Link Event Code}_H - 0x8000_H)$$

Table 7- 10 Overview Error types IO-Link Device Diagnostics

IO-Link Event Code	Error type (CET)	Expanded error type (ECET)	Error text	Meaning
0x0000 - 0x7FFF _H	0x9500 _H (38144 _D)	0x0000 - 0x7FFF _H (0 - 32767 _D)	Error / Warning	See manual of the IO-Link devices or IODD file used.
0x8000 - 0xFFFF _H	0x9501 _H (38134 _D)	0x0000 - 0x7FFF _H (0 - 32767 _D)	Error / Warning	See manual of the IO-Link devices or IODD file used.

Example of Display of IO-Link Event Codes:

An IO-Link device supports the event codes 0x4000_H and 0x8CA0_H.

The channel diagnostics result from the event codes:

- CET: 0x9500_H, ECET: 0x4000_H
Diagnostic alarm "IO-Link Device Diagnostics - Page 1, Temperature fault - Overload", generates Event Code 0x4000_H from the IO-Link.
- CET: 0x9501_H, ECET: 0xCA0_H
Diagnostic alarm "IO-Link Device Diagnostics - Page 2, Ambient light interference, generates Event Code 0x8CA0_H from the IO-Link.

IO-Link Port Diagnostics

The IO-Link master generates channel diagnostics for each port. The port-specific channel diagnostics are display in the port diagnostics (CET 0x9502_H).

The following table provides an overview of the possible diagnostics events and their meaning.

Table 7- 11 Overview Error types IO-Link Port Diagnostics

Error type (CET)	Expanded error type (ECET)	Error text	Meaning
0x9502 _H (38136 _D)	0x1883 _H (6275 _D)	S7-PCT configuration errors	Wrong or inconsistent parameter assignment
	0x1888 _H (6280 _D)	Module defective	Replace module
	0x7F22 _H (32546 _D)	Device not available	Communication aborted
	0x1801 _H (6145 _D)	Parameter assignment error during startup	Check the parameterization
	0x1802 _H (6146 _D)	Wrong device	Check device
	0x1803 _H (6147 _D)	Nonconformance of process data	Check submodule configuration
	0x1804 _H (6148 _D)	Short circuit at C/Q	Check port connection
	0x1805 _H (6149 _D)	IO-Link PHY overtemperature	
	0x1806 _H (6150 _D)	Short circuit at L+	Check port connection
	0x1807 _H (6151 _D)	Undervoltage at L+	Check port connection
	0x1808 _H (6152 _D)	Event overflow at device	
	0x1809 _H (6153 _D)	Backup failed	Memory outside of the area 2k
	0x180A _H (6154 _D)	Backup inconsistent	Data storage index not available
	0x180B _H (6155 _D)	Backup invalid	Length of the data storage index is invalid
	0x7F23 _H (32547 _D)	Backup invalid	Nonconformance in identification of data storage
	0x7F25 _H (32549 _D)	Backup invalid	Access to data storage denied
	0x180E _H (6158 _D)	No P24 (Class B) or undervoltage	Check power supply (for example, 2L+)
	0x180F _H (6159 _D)	Short circuit at P24 (Class B)	Check port connection
	0x6000 _H (24576 _D)	Invalid cycle time	Check cycle time
	0x6001 _H (24577 _D)	Revision error	Incomplete protocol version
	0x6002 _H (24578 _D)	Implausible device	

See also

For more information please refer to the STEP 7 online help and to the programming manual Migration from PROFIBUS DP to PROFINET IO (<http://support.automation.siemens.com/WW/view/en/19289930>).

7.5.4 STOP of the IO Controller and recovery of the IO Device

Diagnostics events triggered after a STOP of the IO Controller

Diagnostics frames received from the IO Device while the IO Controller is in STOP do not trigger the start of corresponding OBs after the restart of the IO Controller. You must explicitly read the diagnostics data from OB 100 to obtain an overview of the device state.

Diagnostics after recovery of the IO Device

You must explicitly read data record E00C_H by calling SFB 52 after recovery of an IO Device. This record contains all diagnostics data for the device slots assigned to an IO Controller

General technical data

8.1 Standards and certifications

Introduction

The ET 200eco PN distributed I/O system satisfies the requirements and criteria of IEC 61131-2.

Note

Information on the nameplate

You will find the currently valid labels and approvals on the type plate of the respective product.

PROFINET IO

PROFINET IO is an open transmission protocol with real-time functionality defined in PROFINET.

CE marking



Our products fulfill the requirements and safety objectives of the following EU Directives and comply with the harmonized European standards (EN) published for programmable logic controllers in the official journals of the European Community:

- 2014/30/EU "Electromagnetic compatibility" (EMC Guidelines)
- 2014/34/EU "Equipment and protective systems for use in hazardous areas" (Explosion protection directive)

The EC Declarations of Conformity are kept available for the responsible authorities at:

Siemens Aktiengesellschaft
Sector Industry
DF FA AS DH AMB
Postfach 1963
D-92209 Amberg

These files are also available for download on the Customer Support Internet pages, under "Declaration of Conformity".

ATEX approval



in accordance with EN 60079-15 (Electrical apparatus for potentially explosive atmospheres; Type of protection "n")
EN 60079-0 (Electrical apparatus for potentially explosive gas atmospheres - Part 0: General Requirements) and
EN 60079-31 (Equipment dust ignition protection by enclosure "t")



II 3 G Ex nA IIC T4 Gc
II 3 D Ex tc IIIC T90°C Dc IP67
DEKRA 12 ATEX 0220 X

For additional information, please refer to the Using the ET 200eco PN in hazardous area Zone 2 / Zone 22 Product Information
(<https://support.industry.siemens.com/cs/ww/en/view/80484830>).

RCM (C-Tick) Declaration of conformity for Australia/New Zealand



The ET 200eco PN distributed I/O system satisfies the requirements of the standards:

- AS/NZS 61000.6.4
- IEC 61000-6-4.

cULus approval



Underwriters Laboratories Inc. in accordance with

- UL 508 (Industrial Control Equipment)
- UL50 Enclosure Type 4X, indoor use only, watertight
- CSA C22.2 No. 142 (Process Control Equipment)

Note

Class 2 power supply unit

The components must be supplied with a class 2 power supply unit.

Industrial applications

SIMATIC products are designed for industrial applications.

Table 8- 1 Industrial applications

Fields of application	Requirements for	
	Noise emission	Interference immunity
Industry	EN 61000-6-4: 2007 + A1 2011	EN 61000-6-2:2005

Operation in residential areas

Note

The ET 200eco PN distributed I/O system is intended for use in industrial environments; when used in residential areas, it can be affected by radio/television reception.

If you use the ET 200eco PN in residential areas, you must ensure the observance of limit values according to EN 61000-6-3 with regard to the emission of interference.

Suitable measures for achieving the required Class B radio interference level include, for example:

- Installation of ET 200eco PN in grounded control cabinets/control boxes
- Use of noise filters in the supply lines

Marine approval

Classification authorities:

- ABS (American Bureau of Shipping)
- BV (Bureau Veritas)
- DNVGL (Det Norske Veritas / Germanischer Lloyd)
- LRS (Lloyds Register of Shipping)
- Class NK (Nippon Kaiji Kyokai)

8.2 EMC compatibility, shipping and storage conditions

Definition

Electromagnetic compatibility is the ability of an electrical device to function in its electromagnetic environment in a satisfactory manner without affecting this environment.

The ET 200eco PN distributed I/O device also meets the requirements of the EMC law of the European Single Market. Prerequisite is compliance of the electrical configuration of the ET 200eco PN distributed I/O device with specifications and directives.

Pulse-shaped disturbances

The table below shows the electromagnetic compatibility of the ET 200eco PN distributed I/O device with respect to pulse-shaped disturbances.

Pulse-shaped disturbance	Test voltage	corresponds with degree of severity
Electrostatic discharge to IEC 61000-4-2	8 kV 6 kV	3 (air discharge) 2 (contact discharge)
Burst pulses (high-speed transient disturbances) according to IEC 61000-4-4.	2 kV (power supply line) 2 kV (signal line)	3 3
High-energy single pulse (surge) according to IEC 61000-4-5 *		3
• Asymmetric coupling	2 kV (power supply line) 2 kV (signal / data line)	
• Symmetric coupling	1 kV (power supply line) 1 kV (signal / data line)	
* On DC 24 V supply only with protective element		

Sinusoidal disturbance variables

The table below shows the electromagnetic compatibility of the ET 200eco PN distributed I/O device with respect to sinusoidal disturbances.

HF radiation according to IEC 61000-4-3 Electromagnetic HF field	HF coupling according to IEC 61000-4-6
Amplitude modulated	
80 to 1000 MHz; 1.4 to 2 GHz	0.15 MHz to 80 MHz
10 V/m 80% AM (1 kHz)	10 V _{rms} unmodulated
2 to 2.7 GHz	80 % AM (1 kHz)
1 V/m at 80 % AM (1 kHz)	150 Ω source impedance

Emission of radio interference

Interference emission of electromagnetic fields according to EN 55016: Limit class A, group 1 (measured at a distance of 10 m).

Frequency	Noise emission
30 MHz to 230 MHz	< 40 dB (μ V/m)Q
230 MHz to 1000 MHz	<47 dB (μ V/m) Q

Shipping and storage conditions

The ET 200eco PN distributed I/O device surpasses the requirements according to IEC 61131-2 for transport and storage conditions. The following information applies to modules transported or stored in their original packaging.

Type of condition	Permissible range
Free fall	≤ 0.3 m
Temperature	from -40 °C to $+70$ °C
Temperature change	20 K/h
Air pressure	1080 hPa to 660 hPa (corresponds with an altitude of -1000 m to 3500 m)
Relative humidity	From 5% to 95%, without condensation

8.3 Mechanical and climatic environmental conditions

Climatic environmental conditions

Applicable climatic environmental conditions:

Environmental conditions	Fields of application	Remarks
Temperature	from 0 °C to 55 °C	All mounting positions
Temperature change	10 K/h	-
Relative humidity	5 % to max. 100 %	With condensation
Air pressure	1080 hPa to 795 hPa	Corresponds to an altitude of -1000 m to 2000 m
Pollutant concentration	SO ₂ : < 0.5 ppm; relative humidity < 60 %, no dewing H ₂ S: < 0.1 ppm; relative humidity < 60 %, no dewing	-

Operating temperature range for the devices

The following devices can be used in different temperature ranges (indoor use only):

Designation	Article number	Fields of application			From product version
		-25 °C to 55 °C	-25 °C to 60 °C	-40 °C to 60 °C	
8 DI DC 24V 4×M12	6ES7141-6BF00-0AB0	X	X		1
		X	X	X	4
8 DI DC 24V 8×M12	6ES7141-6BG00-0AB0	X	X		1
		X	X	X	4
16 DI DC 24V 8×M12	6ES7141-6BH00-0AB0	X	X		1
		X	X	X	4
8 DO DC 24V/1,3A 4×M12	6ES7142-6BF00-0AB0	X	X		1
		X	X	X	4
8 DO DC 24V/0,5A 4×M12	6ES7142-6BF50-0AB0	X	X		1
		X	X	X	4
8 DO DC 24V/1,3A 8×M12	6ES7142-6BG00-0AB0	X	X		1
		X	X	X	4
8 DO DC 24V/2,0A 8×M12	6ES7142-6BR00-0AB0	X	X		1
		X	X	X	4
16 DO DC 24V/1,3A 8×M12	6ES7142-6BH00-0AB0	X	X		1
		X	X	X	4
8 DIO DC 24 V/1,3A 8×M12	6ES7147-6BG00-0AB0	X	X		1
		X	X	X	4
8 AI 4 U/I + 4 RTD/TC 8×M12	6ES7144-6KD00-0AB0	X	X		1
		X	X	X	4

Designation	Article number	Fields of application			From product version
		-25 °C to 55 °C	-25 °C to 60 °C	-40 °C to 60 °C	
8 AI RTD/TC 8×M12	6ES7144-6KD50-0AB0	X	X	X	1
4 AO U/I 4×M12	6ES7145-6HD00-0AB0	X	X		1
		X	X	X	4
4 IO-L + 8 DI + 4 DO DC 24V/1,3A 8×M12	6ES7148-6JA00-0AB0	X	X		1
4 IO-L 4×M12	6ES7148-6JD00-0AB0	X	X	X	1
PD DC 24V 1×7/8" 4×M12	6ES7148-6CB00-0AA0	X			1
Terminal block	6ES7194-6CA00-0AA0	X			1
Mounting rail	6ES7194-6GA00-0AA0	X	X	X	1

Mechanical environmental conditions

The table below shows the mechanical environmental conditions in the form of sinusoidal oscillation.

Devices	Frequency band	Continuous	Tested at ...
Without mounting rail	$10 \leq f \leq 58$ Hz	1.5 mm amplitude	3 mm amplitude
	$58 \leq f \leq 150$ Hz	20 g constant acceleration	40 g constant acceleration
With mounting rail	$5 \leq f \leq 8$ Hz	15 mm amplitude	-
	$8 \leq f \leq 150$ Hz	5 g constant acceleration	10 g constant acceleration

Compatibility test, mechanical environmental conditions

The table below provides information about the type and scope of the tests of mechanical environmental conditions.

Test ...	Test standard	Terminal and I/O devices	
Vibration	Vibration test according to IEC 60068-2-6	Without mounting rail With mounting rail	Type of vibration: Frequency sweeps at a rate of change of 1 octave/minute. 10 Hz \leq f \leq 58 Hz, constant amplitude 3 mm 58 Hz \leq f \leq 150 Hz, constant acceleration 40 g 5 Hz \leq f \leq 12 Hz, constant amplitude 15 mm 12 Hz \leq f \leq 150 Hz, constant acceleration 10 g Duration of vibration: 10 frequency sweeps per axis in each of three perpendicular axes
Shock	Shock, tested in accordance with IEC 60068-2-27	Type of shock: Half-sine Shock intensity: 30 g peak value, 18 ms duration Direction of shock: 3 shocks in each +/- direction at each of the three vertically aligned axes	
Continuous shock	Shock, tested in accordance with IEC 60068-29	Type of shock: Half-sine Shock intensity: 25 g peak value, 6 ms duration Direction of shock: 1000 shocks in each +/- direction at each of the three vertically aligned axes	

Extended environmental conditions for outdoor use

The table below provides information about the type and scope of the tests for extended environmental conditions for outdoor use.

Test ...	Test standard	Conditions/Comments
Salt spray	IEC 60068-2-52	Severity level 1 for products used at sea or close to the ocean: 4 cycles each with: <ul style="list-style-type: none"> • 2 h with 5 % NaCl at 35 °C • 7 days at 40 °C/93 % rel. humidity
UV resistance		Chamber with glass: Sun test CPS plus Fa. Atlas Duration: 12 weeks <ul style="list-style-type: none"> • Irradiance (E): 550 W/m² • Black standard temperature (BST): 55 °C
Condensation changing climate	DIN EN ISO 6270-2	Condensation climate with alternating humidity and air temperature (AHT): 84 cycles each with: <ul style="list-style-type: none"> • 8 h at 40 °C +3 °C with 100% relative humidity (condensation) • 16 h at 18 °C to 28 °C with 100% relative humidity
Thermal shock test	IEC 60068-2-14 Na	Temperature: -40 °C/+125 °C Duration: 500 cycles (500 h) Device is switched off
Hot storage	IEC 60068-2-2 Bb	Temperature: 100 °C Duration: 1 year

Devices for operating range of extended environmental conditions in outdoor use

The following devices can be used for extended environmental conditions in outdoor use:

Designation	Article number	From product version
8 DI DC 24V 4×M12	6ES7141-6BF00-0AB0	4
8 DI DC 24V 8×M12	6ES7141-6BG00-0AB0	4
16 DI DC 24V 8×M12	6ES7141-6BH00-0AB0	4
8 DO DC 24V/1,3A 4×M12	6ES7142-6BF00-0AB0	4
8 DO DC 24V/0,5A 4×M12	6ES7142-6BF50-0AB0	4
8 DO DC 24V/1,3A 8×M12	6ES7142-6BG00-0AB0	4
8 DO DC 24V/2,0A 8×M12	6ES7142-6BR00-0AB0	4
16 DO DC 24V/1,3A 8×M12	6ES7142-6BH00-0AB0	4
8 DIO DC 24 V/1,3A 8×M12	6ES7147-6BG00-0AB0	4
8 AI 4 U/I + 4 RTD/TC 8×M12	6ES7144-6KD00-0AB0	4
8 AI RTD/TC 8×M12	6ES5144-6KD50-0AB0	1
4 AO U/I 4×M12	6ES7145-6HD00-0AB0	4

8.4 Specification of dielectric tests, protection class, degree of protection, and rated voltage of ET 200eco PN

Test voltage

The insulation stability is tested with the following test voltage according to IEC 61131-2 during type testing:

Circuits with Rated voltage V_n against other circuits or ground	Test voltage
< 50 V	DC 500 V
< 150 V	2500 V DC
< 250 V	4000 V DC

Degree of pollution/overvoltage category according to IEC 61131

- Pollution degree 1
- Pollution degree 2 for terminal block and the voltage distributor.
- Overvoltage category
 - at $U_{rated} = DC 24 V: II$

Degree of protection IP 65

Degree of protection according to IEC 60529:

- Protection against the ingress of dust and full touch protection
- Water projected by a nozzle against the enclosure from any direction shall have no harmful effect.

Degree of protection IP66 and IP67

Degree of protection according to IEC 60529:

- Protection against the ingress of dust and full touch protection
- IP66: Protection against water from heavy seas or water projected in powerful jets (water must not enter the enclosure in harmful quantities)
- IP67: Protection against water when enclosure is immersed at specified pressures over a specified time period (water must not enter the enclosure in harmful quantities)

Rated voltage for operation

The ET 200eco PN distributed I/O device operates with the following rated voltage and corresponding tolerances.

Rated voltage	Tolerance range
DC 24 V	20.4 to 28.8 V DC

I/O device digital inputs/digital outputs

9.1 I/O device digital inputs

9.1.1 I/O device 8 DI DC 24 V 4xM12

Article number

6ES7141-6BF00-0AB0

Properties

The 8 DI DC 24V 4xM12 I/O device has the following properties:

- 8 digital inputs
- Dimensions 30 x 200 mm, dual assignment of the sockets
- Rated input voltage DC 24 V
- Suitable for switches and proximity switches
- Diagnostics
 - "Missing 1L+" for the I/O device
 - "Short-circuit to M at sensor supply", per channel group
 - "Wire break", per channel
- Prioritized startup
- Media redundancy

Pin assignment of the DI sockets

The table below shows the pin assignment of the four sockets for connecting the digital inputs

Table 9- 1 Pin assignment of the digital input sockets X1 to X4

Pin	Assignment				View of socket (front view)
	Socket X1	Socket X2	Socket X3	Socket X4	
1	24 V sensor supply 1Us(derived from 1L+ non-switched)				
2	Input signal				
	DI ₄	DI ₅	DI ₆	DI ₇	
3	Sensor supply ground 1M				
4	Input signal				
	DI ₀	DI ₁	DI ₂	DI ₃	
5	Functional earth FE				

Block diagram

The block diagram below shows the 8 DI DC 24V 4×M12 I/O device.

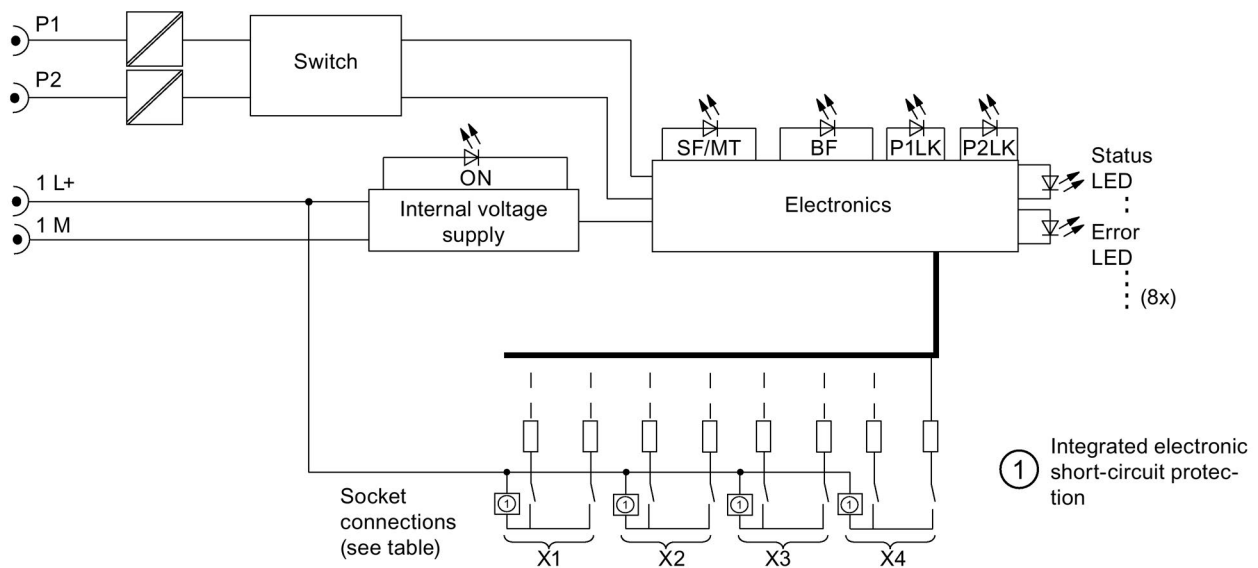

Figure 9-1 Block diagram of the 8 DI DC 24V 4×M12 I/O device

Technical data of the 8 DI DC 24V 4×M12 I/O device

Technical data	
Dimensions and weight	
Dimensions W x H x D (mm)	30 x 200 x 49
Weight	Approx. 550 g
Module-specific data	
Transmission rate	100 Mbps full duplex
Transmission mode	100BASE-TX
Autonegotiation	Yes
Bus protocol	PROFINET IO <ul style="list-style-type: none"> • IRT with the option "high flexibility" • IRT with the option "high performance"
Supported Ethernet services	PROFINET IO (Device) <ul style="list-style-type: none"> • ping • arp • LLDP • Network diagnostics (SNMP) • DCP • Prioritized startup • Media redundancy
PROFINET interface	
• Connection socket	2 x M12 d-coded
• Switch function	Yes, internal
• Auto-crossover	Yes, if autonegotiation is enabled
Manufacturer ID (Vendor ID)	002A _H
Device ID (DeviceID)	0306 _H
Voltages and currents	
Supply voltage 1L+	DC 24 V
• Reverse polarity protection	Yes; against destruction
• Infeed current 1L+	Max. 4 A
Supply voltage 2L+	DC 24 V
• Infeed current 2L+	Max. 4 A
Current consumption	
From supply voltage (1L+)	Typ. 100 mA
Power loss of the device	Typ. 5.5 W
Digital inputs	
Number of inputs	8
Number of inputs that can be controlled simultaneously	8, in all mounting positions
Insulation	
Insulation test voltage	
• Ethernet interface	1500 V _{rms} (IEEE802.3)
• All other circuit elements	707 V DC (type test)

Technical data	
Electrical isolation	
• Between 1L+ and 2L+	Yes
• Between 1L+, channels and all other circuit elements	No
• Between channels	No
• Between Ethernet and all other circuit elements	Yes
Status, interrupts, diagnostics	
Interrupts	Yes
Diagnostics function	Yes
• Group error/maintenance	Red/yellow "SF/MT" LED
• Bus monitoring PROFINET IO	Red "BF" LED
• Monitoring of supply voltage 1L+	Green "ON" LED
• Existing connection to network	Green "P1 LK" and "P2 LK" LED; LED for PROFINET IO infeed and loop-through
• Digital input	Green LED
• Fault at digital input	Red LED
• Diagnostic information can be read	Yes
Monitoring for	
• Short-circuit	Yes, per channel group
• Wire break	Input current < 0.3 mA, per channel
• Missing sensor supply	Yes
Sensor supply	
Number of sensor supplies	4
Load current	100 mA per output
Short-circuit protection	Yes, electronic
Sensor selection data	
Cable length, shielded	Max. 30 m
Cable length, unshielded	Max. 30 m
Input voltage	
• Nominal value	DC 24 V
• For signal "1"	11 to 30 V
• For signal "0"	-3 to +5 V
Input current	
• At signal "1"	Typ. 7 mA
Input delay	
• At "0" to "1"	Typ. 3 ms
• At "1" to "0"	Typ. 3 ms
Input characteristic	According to IEC 61131, Type 3
Connection of 2-wire proximity switches	Supported
• Permitted quiescent current	Max. 1.5 mA

9.1.2 I/O device 8 DI DC 24 V 8xM12

Article number

6ES7141-6BG00-0AB0

Properties

The 8 DI DC 24V 8xM12 I/O device has the following properties:

- 8 digital inputs
- Dimensions 60 x 175 mm, single assignment of the sockets
- Rated input voltage DC 24 V
- Suitable for switches and proximity switches
- Diagnostics
 - "Missing 1L+" for the I/O device
 - "Short-circuit to M at sensor supply" per channel
 - "Wire break", per channel
- Prioritized startup
- Media redundancy

Pin assignment of the sockets

The table below shows the pin assignment of the eight sockets for connecting the digital inputs.

Table 9- 2 Pin assignment of sockets X1 to X8 for digital inputs

Pin	Assignment								View of socket (front view)
	Socket X1	Socket X2	Socket X3	Socket X4	Socket X5	Socket X6	Socket X7	Socket X8	
1	24 V sensor supply 1U _S (derived from 1L+ non-switched)								
2	Not used								
3	Sensor supply ground 1M								
4	Input signal								
	DI ₀	DI ₁	DI ₂	DI ₃	DI ₄	DI ₅	DI ₆	DI ₇	
5	Functional earth FE								

Block diagram

The block diagram below shows the 8 DI DC 24V 8×M12 I/O device.

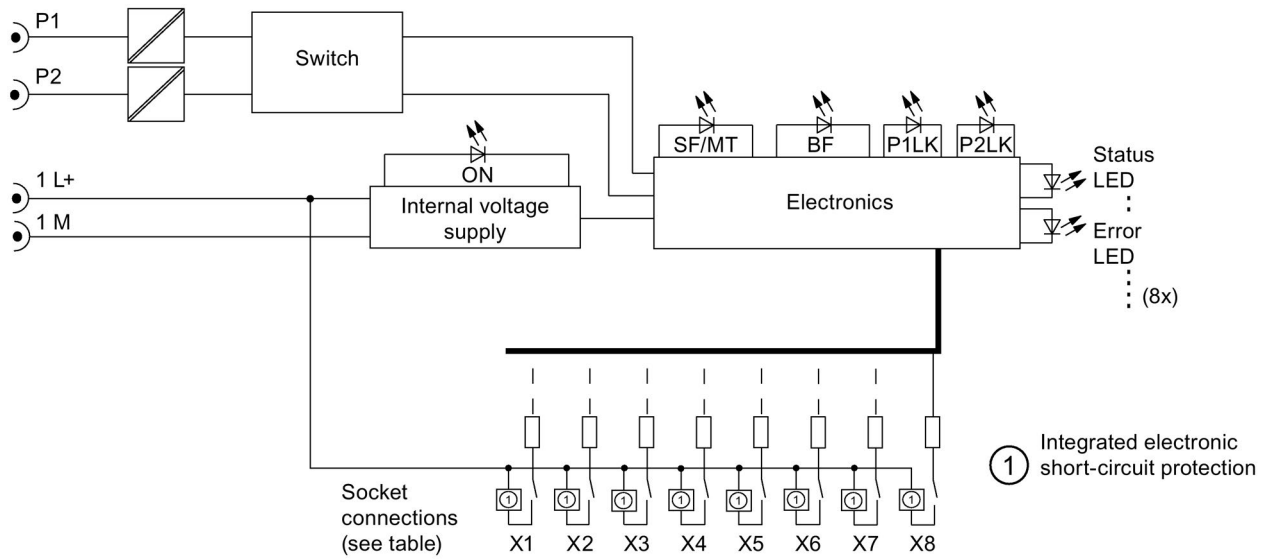

Figure 9-2 Block diagram of the 8 DI DC 24V 8×M12 I/O device

Technical data of the 8 DI DC 24V 8×M12 I/O device

Technical data	
Dimensions and weight	
Dimensions W x H x D (mm)	60 x 175 x 49
Weight	Approx. 910 g
Module-specific data	
Transmission rate	100 Mbps full duplex
Transmission mode	100BASE-TX
Autonegotiation	Yes
Bus protocol	PROFINET IO <ul style="list-style-type: none"> • IRT with the option "high flexibility" • IRT with the option "high performance"
Supported Ethernet services	PROFINET IO (Device) <ul style="list-style-type: none"> • ping • arp • LLDP • Network diagnostics (SNMP) • DCP • Prioritized startup • Media redundancy
PROFINET interface	
• Connection socket	2 x M12 d-coded
• Switch function	Yes, internal
• Auto-crossover	Yes, if autonegotiation is enabled
Manufacturer ID (Vendor ID)	002A _H
Device ID (DeviceID)	0306 _H
Voltages and currents	
Supply voltage 1L+	DC 24 V
• Reverse polarity protection	Yes; against destruction
• Infeed current 1L+	Max. 4 A
Supply voltage 2L+	DC 24 V
• Infeed current 2L+	Max. 4 A
Current consumption	
From supply voltage (1L+)	Typ. 100 mA
From supply voltage (2L+)	0 mA
Power loss of the device	4.5 W, typical
Digital inputs	
Number of inputs	8
Number of inputs that can be controlled simultaneously	8, in all mounting positions

Technical data	
Insulation	
Insulation test voltage	
• Ethernet interface	1500 V _{rms} (IEEE802.3)
• All other circuit elements	707 V DC (type test)
Electrical isolation	
• Between 1L+ and 2L+	Yes
• Between 1L+, channels and all other circuit elements	No
• Between channels	No
• Between Ethernet and all other circuit elements	Yes
Status, interrupts, diagnostics	
Interrupts	Yes
Diagnostics function	Yes
• Group error/maintenance	Red/yellow "SF/MT" LED
• Bus monitoring PROFINET IO	Red "BF" LED
• Monitoring of supply voltage 1L+	Green "ON" LED
• Existing connection to network	Green "P1 LK" and "P2 LK" LED; LED for PROFINET IO infeed and loop-through
• Digital input	Green LED
• Fault at digital input	Red LED
• Diagnostic information can be read	Yes
Monitoring for	
• Short-circuit	Yes, per channel
• Wire break	Input current < 0.3 mA, per channel
• Missing sensor supply	Yes
Sensor supply	
Number of sensor supplies	8
Load current	100 mA per output
Short-circuit protection	Yes, electronic
Sensor selection data	
Cable length, shielded	Max. 30 m
Cable length, unshielded	Max. 30 m
Input voltage	
• Nominal value	DC 24 V
• For signal "1"	11 to 30 V
• For signal "0"	-3 to +5 V

Technical data	
Input current	
• At signal "1"	Typ. 7 mA
Input delay	
• At "0" to "1"	Typ. 3 ms
• At "1" to "0"	Typ. 3 ms
Input characteristic	According to IEC 61131, Type 3
Connection of 2-wire proximity switches	Supported
• Permitted quiescent current	Max. 1.5 mA

9.1.3 I/O device 16 DI DC 24 V 8xM12

Article number

6ES7141-6BH00-0AB0

Properties

The 16 DI DC 24V 8xM12 I/O device has the following properties:

- 16 digital inputs
- Dimensions 60 x 175 mm, dual assignment of the sockets
- Rated input voltage DC 24 V
- Suitable for switches and proximity switches
- Diagnostics
 - "Missing 1L+" for the I/O device
 - "Short-circuit to M at sensor supply", per channel group
 - "Wire break", per channel
- Prioritized startup
- Media redundancy

Pin assignment of the sockets

The table below shows the pin assignment of the eight sockets for connecting the digital inputs.

Table 9- 3 Pin assignment of sockets X1 to X8 for digital inputs

Pin	Assignment								View of socket (front view)
	Socket X1	Socket X2	Socket X3	Socket X4	Socket X5	Socket X6	Socket X7	Socket X8	
1	24 V sensor supply 1Us(derived from 1L+ non-switched)								
2	Input signal								
	DI ₈	DI ₉	DI ₁₀	DI ₁₁	DI ₁₂	DI ₁₃	DI ₁₄	DI ₁₅	
3	Sensor supply ground 1M								
4	Input signal								
	DI ₀	DI ₁	DI ₂	DI ₃	DI ₄	DI ₅	DI ₆	DI ₇	
5	Functional earth FE								

Block diagram

The block diagram below shows the 16 DI DC 24V 8×M12 I/O device.

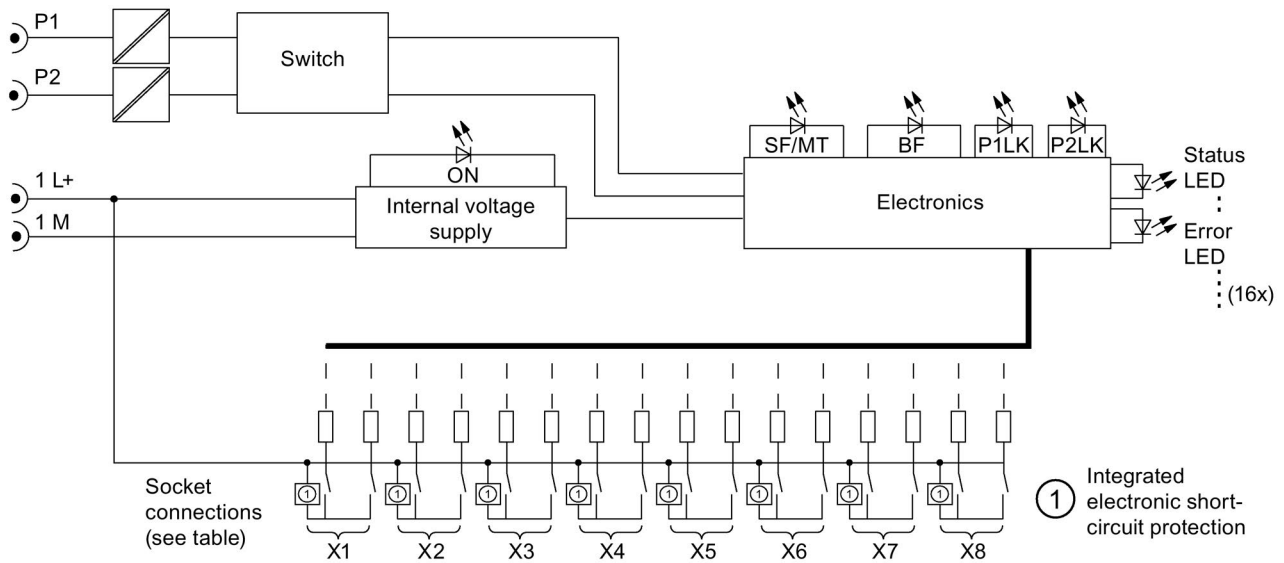

Figure 9-3 Block diagram of the 16 DI DC 24V 8×M12 I/O device

Technical data of the 16 DI DC 24V 8×M12 I/O device

Technical data	
Dimensions and weight	
Dimensions W x H x D (mm)	60 x 175 x 49
Weight	Approx. 910 g
Module-specific data	
Transmission rate	100 Mbps full duplex
Transmission mode	100BASE-TX
Autonegotiation	Yes
Bus protocol	PROFINET IO <ul style="list-style-type: none"> • IRT with the option "high flexibility" • IRT with the option "high performance"
Supported Ethernet services	PROFINET IO (Device) <ul style="list-style-type: none"> • ping • arp • LLDP • Network diagnostics (SNMP) • DCP • Prioritized startup • Media redundancy
PROFINET interface	
• Connection socket	2 x M12 d-coded
• Switch function	Yes, internal
• Auto-crossover	Yes, if autonegotiation is enabled
Manufacturer ID (Vendor ID)	002A _H
Device ID (DeviceID)	0306 _H
Voltages and currents	
Supply voltage 1L+	DC 24 V
• Reverse polarity protection	Yes; against destruction
• Infeed current 1L+	Max. 4 A
Supply voltage 2L+	DC 24 V
• Infeed current 2L+	Max. 4 A
Current consumption	
From supply voltage (1L+)	Typ. 100 mA
From supply voltage (2L+)	0 mA
Power loss of the device	6.5 W, typical
Digital inputs	
Number of inputs	16
Number of inputs that can be controlled simultaneously	16 at all mounting positions

Technical data	
Insulation	
Insulation test voltage	
• Ethernet interface	1500 V _{rms} (IEEE802.3)
• All other circuit elements	707 V DC (type test)
Electrical isolation	
• Between 1L+ and 2L+	Yes
• Between 1L+, channels and all other circuit elements	No
• Between channels	No
• Between Ethernet and all other circuit elements	Yes
Status, interrupts, diagnostics	
Interrupts	Yes
Diagnostics function	Yes
• Group error/maintenance	Red/yellow "SF/MT" LED
• Bus monitoring PROFINET IO	Red "BF" LED
• Monitoring of supply voltage 1L+	Green "ON" LED
• Existing connection to network	Green "P1 LK" and "P2 LK" LED; LED for PROFINET IO infeed and loop-through
• Digital input	Green LED
• Fault at digital input	Red LED
• Diagnostic information can be read	Yes
Monitoring for	
• Short-circuit	Yes, per channel group
• Wire break	Input current < 0.3 mA, per channel
• Missing sensor supply	Yes
Sensor supply	
Number of sensor supplies	8
Load current	100 mA per output
Short-circuit protection	Yes, electronic
Sensor selection data	
Cable length, shielded	Max. 30 m
Cable length, unshielded	Max. 30 m
Input voltage	
• Nominal value	DC 24 V
• For signal "1"	11 to 30 V
• For signal "0"	-3 to +5 V

9.1 I/O device digital inputs

Technical data	
Input current	
• At signal "1"	Typ. 7 mA
Input delay	
• At "0" to "1"	Typ. 3 ms
• At "1" to "0"	Typ. 3 ms
Input characteristic	According to IEC 61131, Type 3
Connection of 2-wire proximity switches	Supported
• Permitted quiescent current	Max. 1.5 mA

9.1.4 Parameter overview digital inputs

Parameters for 8 DI DC 24V 4×M12 (6ES7141-6BF00-0AB0) and for 8 DI DC 24V 8×M12 (6ES7141-6BG00-0AB0)

Parameter	Range of values	Default setting	Range of effectiveness
Group diagnostics	<ul style="list-style-type: none"> Disable Enable 	Disable	Device
Diagnostics: Missing 1L+	<ul style="list-style-type: none"> Disable Enable 	Disable	Device
Diagnostics: Wire break at inputs 0 to 7 (channels 0 to 7)	<ul style="list-style-type: none"> Disable Enable 	Disable	Channel
Diagnostics: Short-circuit to M, inputs 0,4/1,5/2,6/3,7 (channels 0,4/1,5/2,6/3,7)	<ul style="list-style-type: none"> Disable Enable 	Disable	Channel group

Parameters for 16 DI DC 24V 8×M12 (6ES7141-6BH00-0AB0)

Parameter	Range of values	Default setting	Range of effectiveness
Group diagnostics	<ul style="list-style-type: none"> Disable Enable 	Disable	Device
Diagnostics: Missing 1L+	<ul style="list-style-type: none"> Disable Enable 	Disable	Device
Diagnostics: Wire break at inputs 0 to 15 (channels 0 to 15)	<ul style="list-style-type: none"> Disable Enable 	Disable	Channel
Diagnostics: Short-circuit to M, inputs 0,8/1,9/2,10/3,11/4,12/5,13/6,14/7,15 (channels 0,8/1,9/2,10/3,11/4,12/5,13/6,14/7,15)	<ul style="list-style-type: none"> Disable Enable 	Disable	Channel group

9.2 I/O device digital outputs

9.2.1 I/O device 8 DO DC 24 V/1.3A 4xM12

Article number

6ES7142-6BF00-0AB0

Properties

The 8 DO DC 24V/1,3A 4xM12 I/O device has the following properties:

- 8 digital outputs
- Dimensions 30 x 200 mm, dual assignment of the sockets
- Output current: 1.3 A per output
- Rated load voltage DC 24 V
- Suitable for solenoid valves, DC contactors, and indicator lights
- Diagnostics
 - "Missing 1L+ or 2L+" for the I/O device
 - "Wire break at outputs" per channel
 - "Short-circuit to M at outputs" per channel
- Parameterizable response to CPU/Master STOP
- Prioritized startup
- Media redundancy

Pin assignment of the sockets for digital outputs

The table below shows the pin assignment of the four sockets for connecting digital outputs.

Table 9- 4 Pin assignment of sockets X1 to X4 for digital outputs

Pin	Assignment				View of socket (front view)
	Socket X1	Socket X2	Socket X3	Socket X4	
	24 V (1L+ non-switched)		24 V (2L+ switched)		
1	Not used				
2	Output signal				
	DQ ₄	DQ ₅	DQ ₆	DQ ₇	
3	Ground 1M		Ground 2M		
4	Output signal				
	DQ ₀	DQ ₁	DQ ₂	DQ ₃	
5	Functional earth FE				

Block diagram

The block diagram below shows the 8 DO DC 24V/1,3A 4×M12 I/O device.

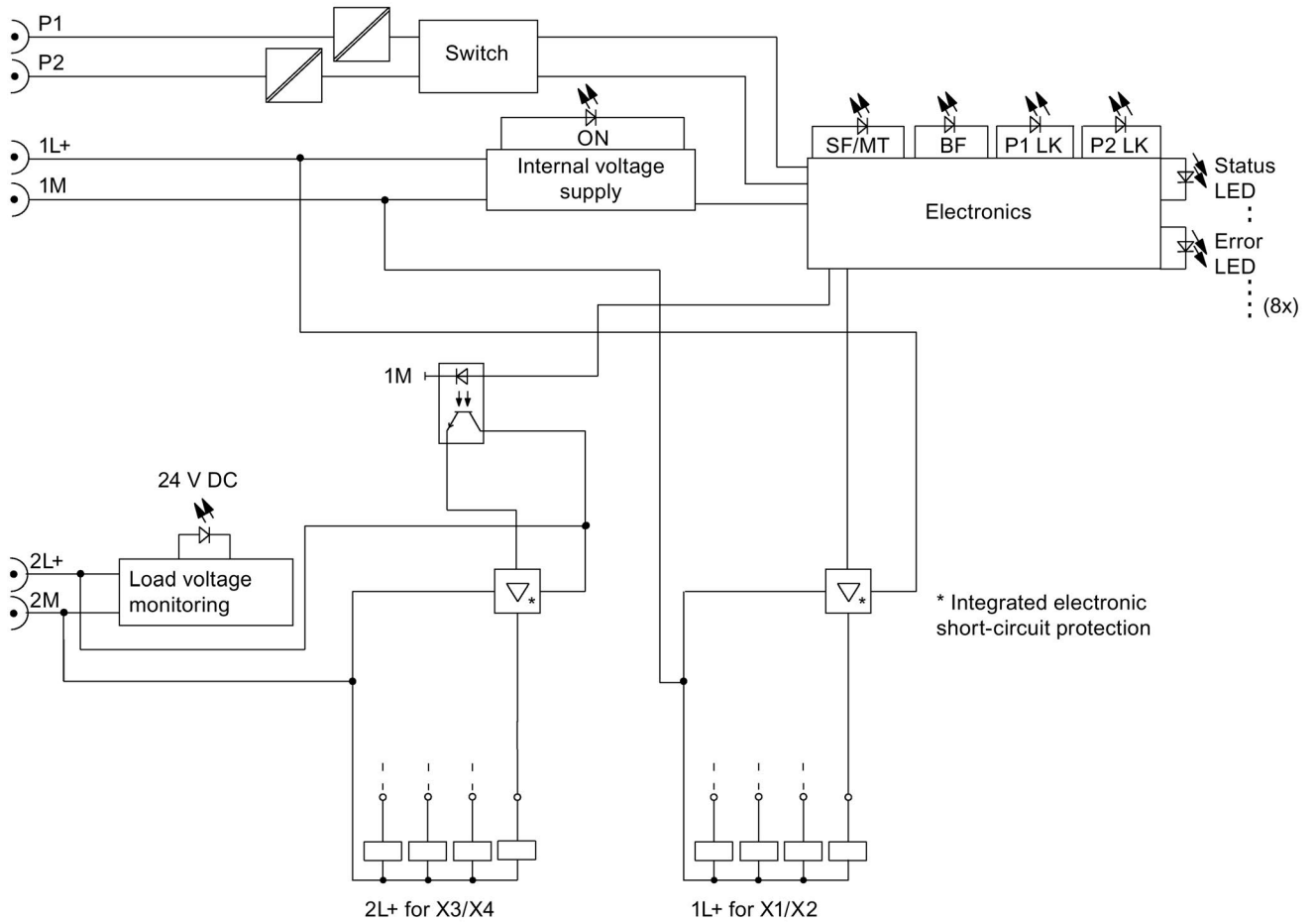

Figure 9-4 Block diagram of the 8 DO DC 24V/1,3A 4×M12 I/O device

Technical data of the 8 DO DC 24V/1,3A 4×M12 I/O device

Technical data	
Dimensions and weight	
Dimensions W x H x D (mm)	30 x 200 x 49
Weight	Approx. 550 g
Module-specific data	
Transmission rate	100 Mbps full duplex
Transmission mode	100BASE-TX
Autonegotiation	Yes
Bus protocol	PROFINET IO <ul style="list-style-type: none"> • IRT with the option "high flexibility" • IRT with the option "high performance"
Supported Ethernet services	PROFINET IO (Device) <ul style="list-style-type: none"> • ping • arp • LLDP • Network diagnostics (SNMP) • DCP • Prioritized startup • Media redundancy
PROFINET interface	
• Connection socket	2 x M12 d-coded
• Switch function	Yes, internal
• Auto-crossover	Yes, if autonegotiation is enabled
Manufacturer ID (Vendor ID)	002A _H
Device ID (DeviceID)	0306 _H
Voltages and currents	
Supply voltage 1L+	DC 24 V
• Reverse polarity protection	Yes, against destruction, loads are activated
• Infeed current 1L+	Max. 4 A
Supply voltage 2L+	DC 24 V
• Reverse polarity protection	Yes, against destruction, loads are activated
• Infeed current 2L+	Max. 4 A
Total current of the outputs *	
• All mounting positions to 55°C	3.9 A per 1L+ and 2L+
• All mounting positions to 60°C	2.6 A per 1L+ and 2L+
Current consumption	
From supply voltage (1L+)	Typ. 100 mA
Power loss of the device	Typ. 5.5 W

Technical data	
Digital outputs	
Number of outputs	8
Insulation	
Insulation test voltage	
• Ethernet interface	1500 V _{rms} (IEEE802.3)
• All other circuit elements	707 V DC (type test)
Electrical isolation	
• Between 1L+ and 2L+	Yes
• Between 1L+, channels and all other circuit elements	No
• Between channels	No
• Between Ethernet and all other circuit elements	Yes
Status, interrupts, diagnostics	
Interrupts	Yes
Diagnostics function	Yes
• Group error/maintenance	Red/yellow "SF/MT" LED
• Bus monitoring PROFINET IO	Red "BF" LED
• Monitoring of supply voltage 1L+	Green "ON" LED
• Monitoring of supply voltage 2L+	Green "DC24V" LED
• Existing connection to network	Green "P1 LK" and "P2 LK" LED; LED for PROFINET IO infeed and loop-through
• Digital output	Green LED
• Fault at digital output	Red LED
• Diagnostic information can be read	Yes
Monitoring for	
• Short-circuit	Yes
• Wire break	Yes, in the off state, per channel
• Failure of 1L+ and 2L+	Yes
Actuator selection data	
Cable length, shielded	Max. 30 m
Cable length, unshielded	Max. 30 m
Output voltage	
• Nominal value	DC 24 V
• For signal "1"	Min. 1L+/2L+ (-0.8 V)
Output current	
• At signal "1"	Max. 1.3 A

Technical data	
• For "0" signal (residual current)	Max. 1.5 mA
Load resistance range	22 Ω to 3.3 kΩ
Lamp load	Max. 5 W
Parallel wiring of two outputs	
• To increase performance	No
• For redundant control of a load	Supported
Controlling of a digital input	Yes
Switching frequency	
• With resistive load	Max. 100 Hz
• With inductive load	Max. 0.5 Hz
• With lamp load	Max. 1 Hz
Limiting of the inductive shutdown voltage to lamp load	Typ. 1L+/2L+ (-47 V)
Short-circuit protection of the output	Yes, electronic
• Response threshold	Typ. 1.8 A (per channel)
* Make allowances for the maximum total current when configuring the module.	

9.2.2 I/O device 8 DO DC 24 V/0.5A 4xM12

Article number

6ES7142-6BF50-0AB0

Properties

The 8 DO DC 24V/0,5A 4xM12 I/O device has the following properties:

- 8 digital outputs
- Dimensions 30 x 200 mm, dual assignment of the sockets
- Output current: 0.5 A per output
- Rated load voltage DC 24 V
- Suitable for solenoid valves, DC contactors, and indicator lights
- Diagnostics
 - "Missing 1L+ or 2L+" for the I/O device
 - "Wire break at outputs" per channel
 - "Short-circuit to M at outputs" per channel
- Parameterizable response to CPU/Master STOP
- Prioritized startup
- Media redundancy

Pin assignment of the sockets

The table below shows the pin assignment of the four sockets for connecting digital outputs.

Table 9- 5 Pin assignment of sockets X1 to X4 for digital outputs

Pin	Assignment				View of socket (front view)
	Socket X1	Socket X2	Socket X3	Socket X4	
1	Not used				
2	Output signal				
	DQ ₄	DQ ₅	DQ ₆	DQ ₇	
3	Ground 2M				
4	Output signal				
	DQ ₀	DQ ₁	DQ ₂	DQ ₃	
5	Functional earth FE				

Block diagram

The block diagram below shows the 8 DO DC 24V/0,5A 4×M12 I/O device.

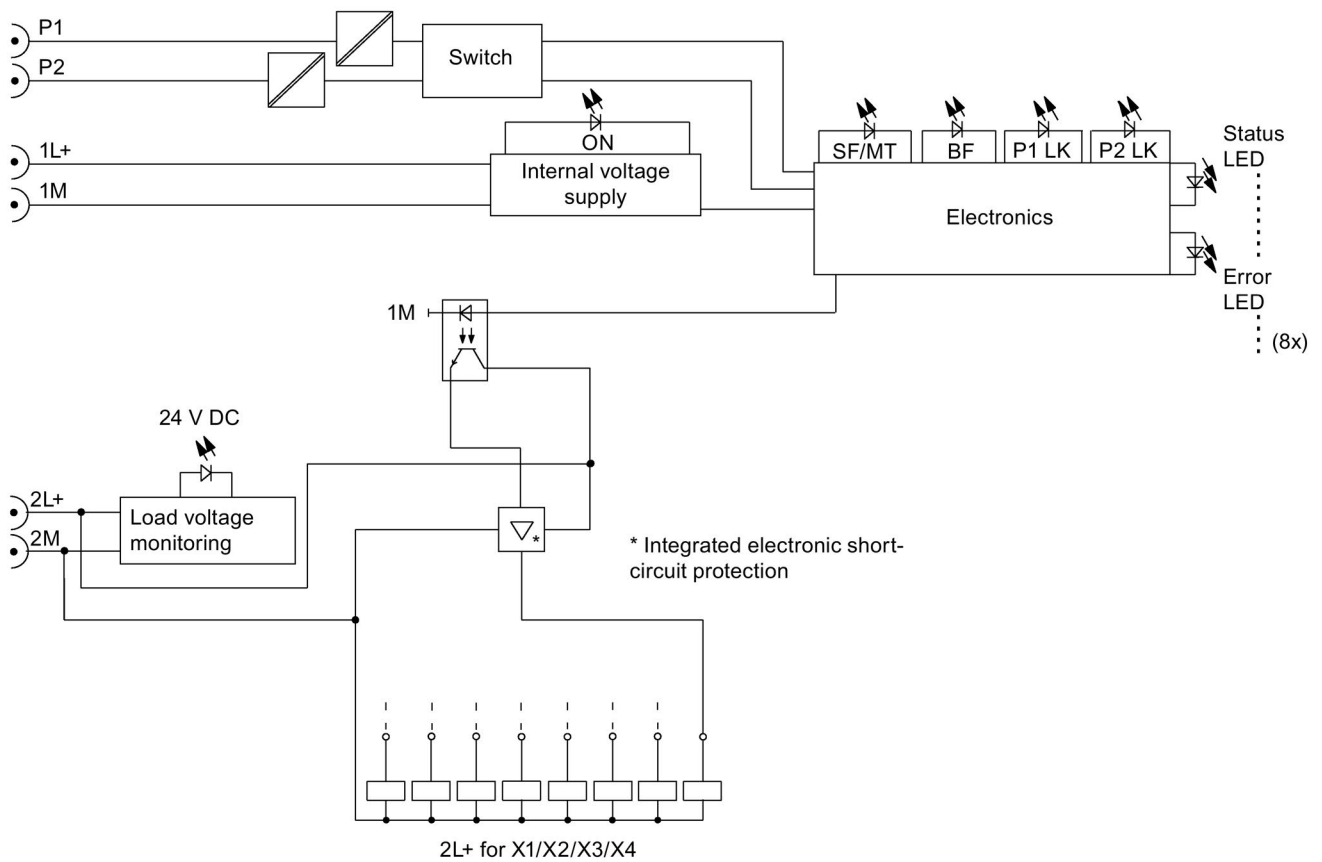

Figure 9-5 Block diagram of the 8 DO DC 24V/0,5 A 4×M12 I/O device

Technical data of the 8 DO DC 24V/0,5A 4×M12 I/O device

Technical data	
Dimensions and weight	
Dimensions W x H x D (mm)	30 x 200 x 49
Weight	Approx. 550 g
Module-specific data	
Transmission rate	100 Mbps full duplex
Transmission mode	100BASE-TX
Autonegotiation	Yes
Bus protocol	PROFINET IO <ul style="list-style-type: none"> • IRT with the option "high flexibility" • IRT with the option "high performance"
Supported Ethernet services	PROFINET IO (Device) <ul style="list-style-type: none"> • ping • arp • LLDP • Network diagnostics (SNMP) • DCP • Prioritized startup • Media redundancy
PROFINET interface	
• Connection socket	2 x M12
• Switch function	Yes, internal
• Auto-crossover	Yes, if autonegotiation is enabled
Manufacturer ID (Vendor ID)	002A _H
Device ID (DeviceID)	0306 _H
Voltages and currents	
Supply voltage 1L+	DC 24 V
• Reverse polarity protection	Yes, against destruction, loads are activated
• Infeed current 1L+	Max. 4 A
Supply voltage 2L+	DC 24 V
• Reverse polarity protection	Yes, against destruction, loads are activated
• Infeed current 2L+	Max. 4 A
Total current of the outputs	
• All mounting positions to 60°C	Max. 4 A (only 2L+)

Technical data	
Electrical isolation	
• Between 1L+ and 2L+	Yes
• Between 1L+, channels and all other circuit elements	No
• Between channels	No
• Between Ethernet and all other circuit elements	Yes
Insulation	
Insulation test voltage	
• Ethernet interface	1500 V _{rms} (IEEE802.3)
• All other circuit elements	707 V DC (type test)
Current consumption	
• From supply voltage (1L+)	Typ. 100 mA
• From supply voltage (2L+)	Typ. 5 mA
Power loss of the device	Typ. 3 W
Digital outputs	
Number of outputs	8
Status, interrupts, diagnostics	
Interrupts	Yes
Diagnostics function	Yes
• Group error/maintenance	Red/yellow "SF/MT" LED
• Bus monitoring PROFINET IO	Red "BF" LED
• Monitoring of supply voltage 1L+	Green "ON" LED
• Monitoring of supply voltage 2L+	Green "DC24V" LED
• Existing connection to network	Green LED "P1 LK" and "P2 LK";
• Digital output	Green LED
• Fault at digital output	Red LED
• Diagnostic information can be read	Yes
Monitoring for	
• Failures of 2L+	Yes
• Short-circuit	Yes
• Wire break	Yes, in the off state, per channel
Actuator selection data	
Cable length, shielded	Max. 30 m
Cable length, unshielded	Max. 30 m

Technical data	
Output voltage	
• Nominal value	DC 24 V
• For signal "1"	Min. 1L+/2L+ (-0.8 V)
Output current	
• At signal "1"	0.5 A
• For "0" signal (residual current)	Max. 1.5 mA
Load resistance range	48 Ω to 3.3 kΩ
Lamp load	Max. 5 W
Parallel wiring of two outputs	
• To increase performance	No
• For redundant control of a load	Supported
Control of a digital input	Yes
Switching frequency	
• With resistive load	Max. 100 Hz
• With inductive load	Max. 0.5 Hz
• With lamp load	Max. 1 Hz
Limiting of the inductive shutdown voltage to lamp load	Typ. 1L+/2L+ (-47 V)
Short-circuit protection of the output	Yes, electronic
• Response threshold	Typ. 0.7 A (per channel)

9.2.3 I/O device 8 DO DC 24 V/1.3A 8xM12

Article number

6ES7142-6BG00-0AB0

Properties

The 8 DO DC 24V/1,3A 8xM12 I/O device has the following properties:

- 8 digital outputs
- Dimensions 60 x 175 mm, single assignment of the sockets
- Output current: 1.3 A per output
- Rated load voltage DC 24 V
- Suitable for solenoid valves, DC contactors, and indicator lights
- Diagnostics
 - "Missing 1L+ or 2L+" for the I/O device
 - "Wire break at outputs" per channel
 - "Short-circuit to M at outputs" per channel
- Parameterizable response to CPU/Master STOP
- Prioritized startup
- Media redundancy

Pin assignment of the sockets

The table below shows the pin assignment of the eight sockets for connecting digital outputs.

Table 9- 6 Pin assignment of sockets X1 to X8 for digital outputs

Pin	Assignment								View of socket (front view)
	Socket X1	Socket X2	Socket X3	Socket X4	Socket X5	Socket X6	Socket X7	Socket X8	
	24 V (1L+ non-switched)				24 V (2L+ switched)				
1	Not used								
2	Not used								
3	Ground 1M				Ground 2M				
4	Output signal								
	DQ ₀	DQ ₁	DQ ₂	DQ ₃	DQ ₄	DQ ₅	DQ ₆	DQ ₇	
5	Functional earth FE								

Block diagram

The block diagram below shows the 8 DO DC 24V/1,3A 8×M12 I/O device.

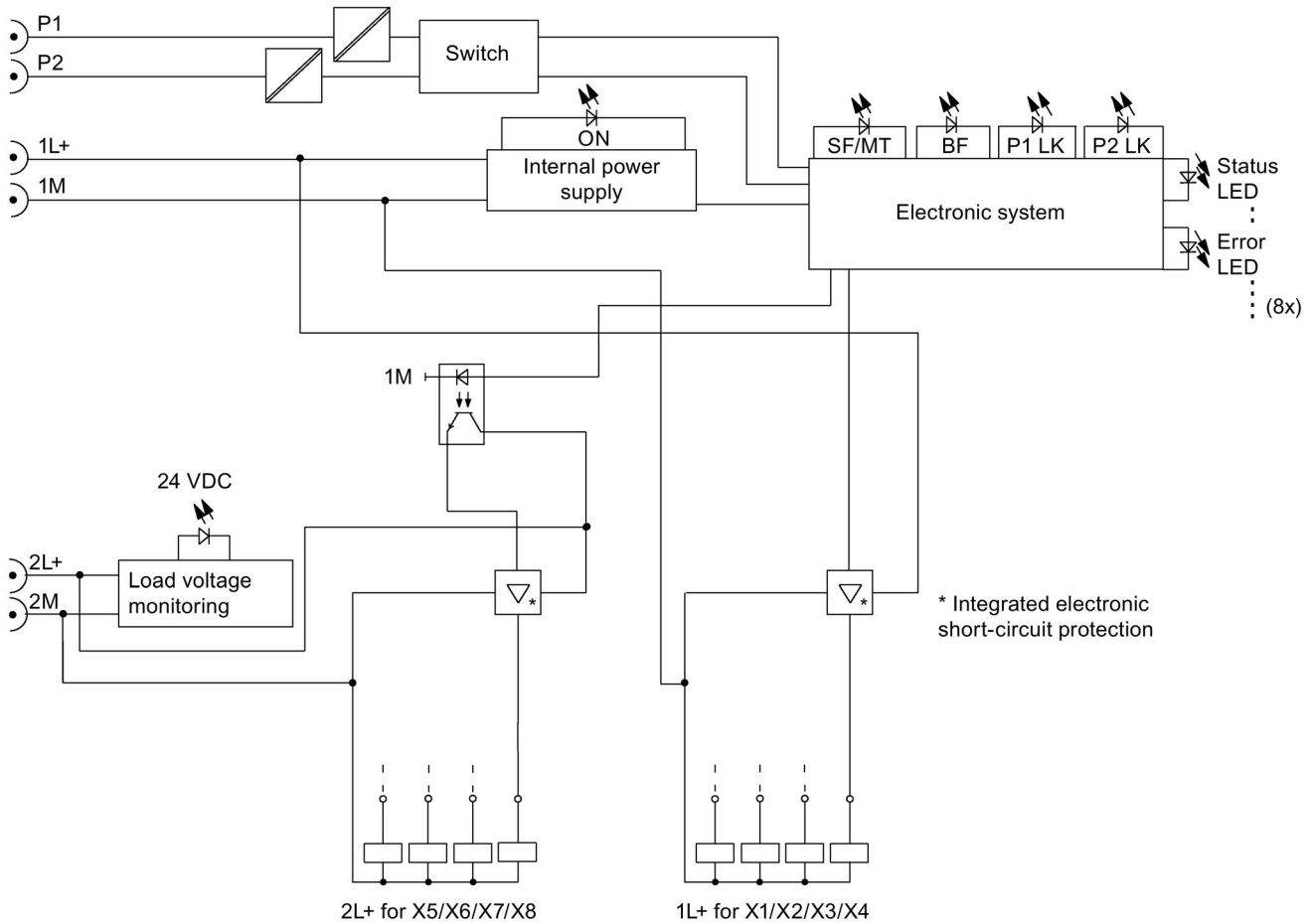

Figure 9-6 Block diagram of the 8 DO DC 24V/1,3A 8×M12 I/O device

Technical data of the 8 DO DC 24V/1,3A 8×M12 I/O device

Technical data	
Dimensions and weight	
Dimensions W x H x D (mm)	60 x 175 x 49
Weight	Approx. 910 g
Module-specific data	
Transmission rate	100 Mbps full duplex
Transmission mode	100BASE-TX
Autonegotiation	Yes
Bus protocol	PROFINET IO <ul style="list-style-type: none"> • IRT with the option "high flexibility" • IRT with the option "high performance"
Supported Ethernet services	PROFINET IO (Device) <ul style="list-style-type: none"> • ping • arp • LLDP • Network diagnostics (SNMP) • DCP • Prioritized startup • Media redundancy
PROFINET interface	
• Connection socket	2 x M12 d-coded
• Switch function	Yes, internal
• Auto-crossover	Yes, if autonegotiation is enabled
Manufacturer ID (Vendor ID)	002A _H
Device ID (DeviceID)	0306 _H
Voltages and currents	
Supply voltage 1L+	DC 24 V
• Reverse polarity protection	Yes, against destruction, loads are activated
• Infeed current 1L+	Max. 4 A
Supply voltage 2L+	DC 24 V
• Reverse polarity protection	Yes, against destruction, loads are activated
• Infeed current 2L+	Max. 4 A
Total current of the outputs *	
• All mounting positions to 60°C	Max. 3.9 A per 1L+ and 2L+
Current consumption	
From supply voltage (1L+)	Typ. 100 mA
From supply voltage (2L+)	Typ. 5 mA
Power loss of the device	Typ. 5.5 W

Technical data	
Digital outputs	
Number of outputs	8
Insulation	
Insulation test voltage	
• Ethernet interface	1500 V _{rms} (IEEE802.3)
• All other circuit elements	707 V DC (type test)
Electrical isolation	
• Between 1L+ and 2L+	Yes
• Between 1L+, channels and all other circuit elements	No
• Between channels	No
• Between Ethernet and all other circuit elements	Yes
Status, interrupts, diagnostics	
Interrupts	Yes
Diagnostics function	Yes
• Group error/maintenance	Red/yellow "SF/MT" LED
• Bus monitoring PROFINET IO	Red "BF" LED
• Monitoring of supply voltage 1L+	Green "ON" LED
• Monitoring of supply voltage 2L+	Green "DC24V" LED
• Existing connection to network	Green "P1 LK" and "P2 LK" LED; LED for PROFINET IO infeed and loop-through
• Digital output	Green LED
• Fault at digital output	Red LED
• Diagnostic information can be read	Yes
Monitoring for	
• Failure of 1L+ and 2L+	Yes
• Short-circuit	Yes, per channel
• Wire break	Yes, in the off state, per channel
Actuator selection data	
Cable length, shielded	Max. 30 m
Cable length, unshielded	Max. 30 m
Output voltage	
• Nominal value	DC 24 V
• For signal "1"	Min. 1L+/2L+ (-0.8 V)

Technical data	
Output current	
• At signal "1"	Max. 1.3 A
• For "0" signal (residual current)	Max. 1.5 mA
Load resistance range	22 Ω to 3.3 k Ω
Lamp load	Max. 5 W
Parallel wiring of two outputs	
• To increase performance	No
• For redundant control of a load	Supported
Control of a digital input	Yes
Switching frequency	
• With resistive load	Max. 100 Hz
• With inductive load	Max. 0.5 Hz
• With lamp load	Max. 1 Hz
Limiting of the inductive shutdown voltage to lamp load	Typ. 1L+/2L+ (-47 V)
Short-circuit protection of the output	Yes, electronic
• Response threshold	Typ. 1.8 A (per channel)
* Make allowances for the maximum total current when configuring the module.	

9.2.4 I/O device 8 DO DC 24V/2.0A 8xM12

Article number

6ES7142-6BR00-0AB0

Properties

The 8 DO DC 24V/2,0A 8xM12 I/O device has the following properties:

- 8 digital outputs
- Dimensions 60 x 175 mm, single assignment of the sockets
- Output current: 2.0 A per output
- Rated load voltage DC 24 V
- Suitable for solenoid valves, DC contactors, and indicator lights
- Diagnostics
 - "Missing 1L+ or 2L+" for the I/O device
 - "Wire break at outputs" per channel
 - "Short-circuit to M at outputs" per channel
- Parameterizable response to CPU/Master STOP
- Prioritized startup
- Media redundancy

Pin assignment of the sockets

The table below shows the pin assignment of the eight sockets for connecting digital outputs.

Table 9- 7 Pin assignment of sockets X1 to X8 for digital outputs

Pin	Assignment								View of socket (front view)
	Socket X1	Socket X2	Socket X3	Socket X4	Socket X5	Socket X6	Socket X7	Socket X8	
	24 V (1L+ non-switched)				24 V (2L+ switched)				
1	Not used								
2	Not used								
3	Ground 1M				Ground 2M				
4	Output signal								
	DQ ₀	DQ ₁	DQ ₂	DQ ₃	DQ ₄	DQ ₅	DQ ₆	DQ ₇	
5	Functional earth FE								

Block diagram

The block diagram below shows the 8 DO DC 24V/2,0A 8×M12 I/O device.

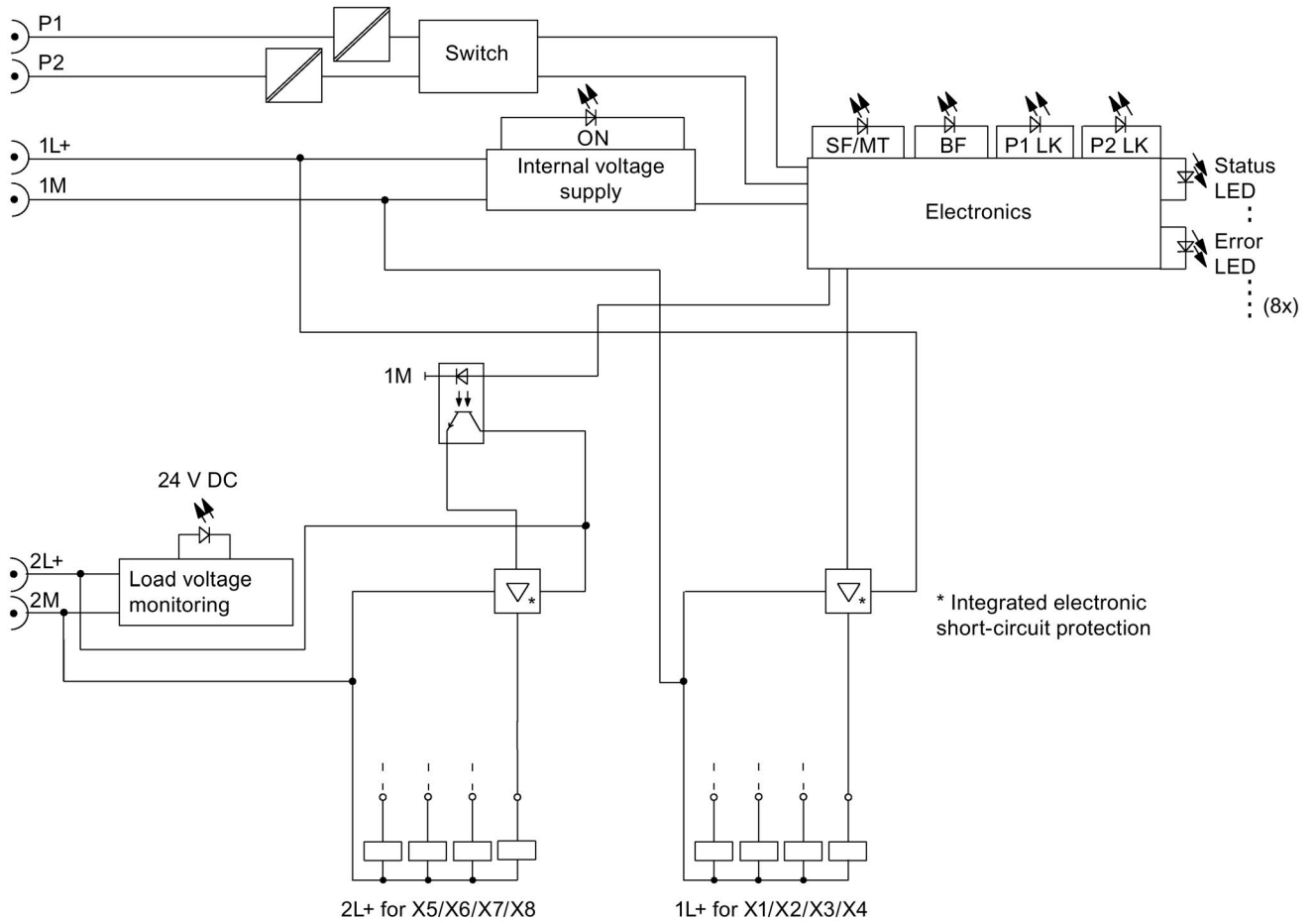

Figure 9-7 Block diagram of the 8 DO DC 24V/2,0A 8×M12 I/O device

Technical data of the 8 DO DC 24V/2,0A 8×M12 I/O device

Technical data	
Dimensions and weight	
Dimensions W x H x D (mm)	60 x 175 x 49
Weight	Approx. 910 g
Module-specific data	
Transmission rate	100 Mbps full duplex
Transmission mode	100BASE-TX
Autonegotiation	Yes
Bus protocol	PROFINET IO <ul style="list-style-type: none"> • IRT with the option "high flexibility" • IRT with the option "high performance"
Supported Ethernet services	PROFINET IO (Device) <ul style="list-style-type: none"> • ping • arp • LLDP • Network diagnostics (SNMP) • DCP • Prioritized startup • Media redundancy
PROFINET interface	
• Connection socket	2 x M12 d-coded
• Switch function	Yes, internal
• Auto-crossover	Yes, if autonegotiation is enabled
Manufacturer ID (Vendor ID)	002A _H
Device ID (DeviceID)	0306 _H
Voltages and currents	
Supply voltage 1L+	DC 24 V
• Reverse polarity protection	Yes, against destruction, loads are activated
• Infeed current 1L+	Max. 4 A
Supply voltage 2L+	DC 24 V
• Reverse polarity protection	Yes, against destruction, loads are activated
• Infeed current 2L+	Max. 4 A
Total current of the outputs *	
• All mounting positions to 60°C	Max. 3.9 A 1L+ and max. 4 A 2L+
Current consumption	
From supply voltage (1L+)	Typ. 100 mA
From supply voltage (2L+)	Typ. 5 mA
Power loss of the device	Typ. 5 W

Technical data	
Digital outputs	
Number of outputs	8
Insulation	
Insulation test voltage	
• Ethernet interface	1500 V _{rms} (IEEE802.3)
• All other circuit elements	707 V DC (type test)
Electrical isolation	
• Between 1L+ and 2L+	Yes
• Between 1L+, channels and all other circuit elements	No
• Between channels	No
• Between Ethernet and all other circuit elements	Yes
Status, interrupts, diagnostics	
Interrupts	Yes
Diagnostics function	Yes
• Group error/maintenance	Red/yellow "SF/MT" LED
• Bus monitoring PROFINET IO	Red "BF" LED
• Monitoring of supply voltage 1L+	Green "ON" LED
• Monitoring of supply voltage 2L+	Green "DC24V" LED
• Existing connection to network	Green "P1 LK" and "P2 LK" LED; LED for PROFINET IO infeed and loop-through
• Digital output	Green LED
• Fault at digital output	Red LED
• Diagnostic information can be read	Yes
Monitoring for	
• Failure of 1L+ and 2L+	Yes
• Short-circuit	Yes, per channel
• Wire break	Yes, in the off state, per channel
Actuator selection data	
Cable length, shielded	Max. 30 m
Cable length, unshielded	Max. 30 m
Output voltage	
• Nominal value	DC 24 V
• For signal "1"	Min. 1L+/2L+ (-0.8 V)

Technical data	
Output current	
• At signal "1"	2.0 A
• For "0" signal (residual current)	Max. 1.5 mA
Load resistance range	12 Ω to 3.3 k Ω
Lamp load	Max. 10 W
Parallel wiring of two outputs	
• To increase performance	No
• For redundant control of a load	Supported
Control of a digital input	Yes
Switching frequency	
• With resistive load	Max. 100 Hz
• With inductive load	Max. 0.5 Hz
• With lamp load	Max. 1 Hz
Limiting of the inductive shutdown voltage to lamp load	Typ. 1L+/2L+ (-47 V)
Short-circuit protection of the output	Yes, electronic
• Response threshold	Typ. 2.8 A (per channel)
* Make allowances for the maximum total current when configuring the module.	

9.2.5 I/O device 16 DO DC 24 V/1.3A 8xM12

Article number

6ES7142-6BH00-0AB0

Properties

The 16 DO DC 24V/1,3A 8xM12 I/O device has the following properties:

- 16 digital outputs
- Dimensions 60 x 175 mm, dual assignment of the sockets
- Output current: 1.3 A per output
- Rated load voltage DC 24 V
- Suitable for solenoid valves, DC contactors, and indicator lights
- Diagnostics
 - "Missing 1L+ and 2L+" for the I/O device
 - "Wire break at outputs" per channel
 - "Short-circuit to M at outputs" per channel
- Parameterizable response to CPU/Master STOP
- Prioritized startup
- Media redundancy

Pin assignment of the sockets

The table below shows the pin assignment of the eight sockets for connecting digital outputs.

Table 9- 8 Pin assignment of sockets X1 to X8 for digital outputs

Pin	Assignment								View of socket (front view)
	Socket X1	Socket X2	Socket X3	Socket X4	Socket X5	Socket X6	Socket X7	Socket X8	
	24 V (1L+ non-switched)				24 V (2L+ switched)				
1	Not used								
2	Output signal								
	DQ ₈	DQ ₉	DQ ₁₀	DQ ₁₁	DQ ₁₂	DQ ₁₃	DQ ₁₄	DQ ₁₅	
3	Ground 1M				Ground 2M				
4	Output signal								
	DQ ₀	DQ ₁	DQ ₂	DQ ₃	DQ ₄	DQ ₅	DQ ₆	DQ ₇	
5	Functional earth FE								

Block diagram

The block diagram below shows the 16 DO DC 24V/1,3A 8×M12 I/O device.

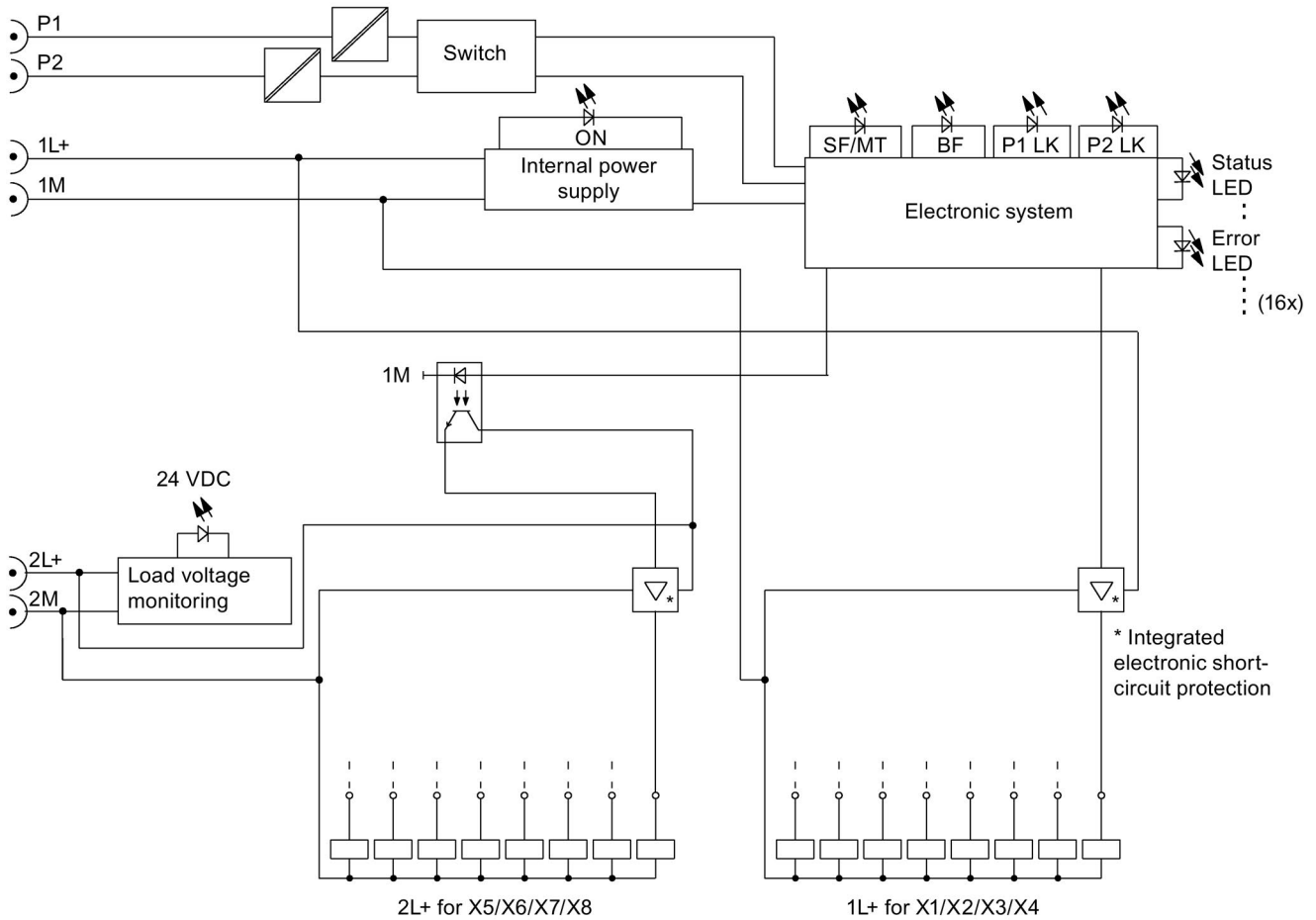

Figure 9-8 Block diagram of the 16 DO DC 24V/1,3A 8×M12 I/O device

Technical data of the 16 DO DC 24V/1,3A 8×M12 I/O device

Technical data	
Dimensions and weight	
Dimensions W x H x D (mm)	60 x 175 x 49
Weight	Approx. 910 g
Module-specific data	
Transmission rate	100 Mbps full duplex
Transmission mode	100BASE-TX
Autonegotiation	Yes
Bus protocol	PROFINET IO <ul style="list-style-type: none"> • IRT with the option "high flexibility" • IRT with the option "high performance"
Supported Ethernet services	PROFINET IO (Device) <ul style="list-style-type: none"> • ping • arp • LLDP • Network diagnostics (SNMP) • DCP • Prioritized startup • Media redundancy
PROFINET interface	
• Connection socket	2 x M12 d-coded
• Switch function	Yes, internal
• Auto-crossover	Yes, if autonegotiation is enabled
Manufacturer ID (Vendor ID)	002A _H
Device ID (DeviceID)	0306 _H
Voltages and currents	
Supply voltage 1L+	DC 24 V
• Reverse polarity protection	Yes, against destruction, loads are activated
• Infeed current 1L+	Max. 4 A
Supply voltage 2L+	DC 24 V
• Reverse polarity protection	Yes, against destruction, loads are activated
• Infeed current 2L+	Max. 4 A
Total current of the outputs *	
• All mounting positions to 60°C	Max. 3.9 A per 1L+ and 2L+
Current consumption	
From supply voltage (1L+)	Typ. 100 mA
From supply voltage (2L+)	Typ. 5 mA
Power loss of the device	Typ. 5.5 W

Technical data	
Digital outputs	
Number of outputs	16
Insulation	
Insulation test voltage	
• Ethernet interface	1500 V _{rms} (IEEE802.3)
• All other circuit elements	707 V DC (type test)
Electrical isolation	
• Between 1L+ and 2L+	Yes
• Between 1L+, channels and all other circuit elements	No
• Between channels	No
• Between Ethernet and all other circuit elements	Yes
Status, interrupts, diagnostics	
Interrupts	Yes
Diagnostics function	Yes
• Group error/maintenance	Red/yellow "SF/MT" LED
• Bus monitoring PROFINET IO	Red "BF" LED
• Monitoring of supply voltage 1L+	Green "ON" LED
• Monitoring of supply voltage 2L+	Green "DC24V" LED
• Existing connection to network	Green "P1 LK" and "P2 LK" LED; LED for PROFINET IO infeed and loop-through
• Digital output	Green LED
• Fault at digital output	Red LED
• Diagnostic information can be read	Yes
Monitoring for	
• Failure of 1L+ and 2L+	Yes
• Short-circuit	Yes, per channel
• Wire break	Yes, in the off state, per channel
Actuator selection data	
Cable length, shielded	Max. 30 m
Cable length, unshielded	Max. 30 m
Output voltage	
• Nominal value	DC 24 V
• For signal "1"	Min. 1L+/2L+ (-0.8 V)

Technical data	
Output current	
• At signal "1"	Max. 1.3 A
• For "0" signal (residual current)	Max. 1.5 mA
Load resistance range	22 Ω to 3.3 k Ω
Lamp load	Max. 5 W
Parallel wiring of two outputs	
• To increase performance	No
• For redundant control of a load	Supported
Control of a digital input	Yes
Switching frequency	
• With resistive load	Max. 100 Hz
• With inductive load	Max. 0.5 Hz
• With lamp load	Max. 1 Hz
Limiting of the inductive shutdown voltage to lamp load	Typ. 1L+/2L+ (-47 V)
Short-circuit protection of the output	Yes, electronic
• Response threshold	Typ. 1.8 A (per channel)
* Make allowances for the maximum total current when configuring the module.	

9.2.6 Parameter overview digital outputs

Parameters for

- 8 DO DC 24V/1,3A 4×M12 (6ES7142-6BF00-0AB0)
- 8 DO DC 24V/1,3A 8×M12 (6ES7142-6BG00-0AB0)
- 8 DO DC 24V/2,0A 8×M12 (6ES7142-6BR00-0AB0)

Parameter	Range of values	Default setting	Range of effectiveness
Group diagnostics	<ul style="list-style-type: none"> • Disable • Enable 	Disable	Device
Diagnostics: Missing 1L+ or 2L+	<ul style="list-style-type: none"> • Disable • Enable 	Disable	Channel group
Response to CPU/Master STOP	<ul style="list-style-type: none"> • Shut down • Retain last value 	Shut down	Device
Diagnostics: Wire break at outputs 0 to 7 (channels 0 to 7)	<ul style="list-style-type: none"> • Disable • Enable 	Disable	Channel
Diagnostics: Short circuit to M, outputs 0 to 7 (channels 0 to 7)	<ul style="list-style-type: none"> • Disable • Enable 	Disable	Channel

Parameters for 8 DO DC 24V/0,5A 4×M12 (6ES7142-6BF50-0AB0)

Parameter	Range of values	Default setting	Range of effectiveness
Group diagnostics	<ul style="list-style-type: none"> • Disable • Enable 	Disable	Device
Diagnostics: Missing 2L+	<ul style="list-style-type: none"> • Disable • Enable 	Disable	Device
Response to CPU/Master STOP	<ul style="list-style-type: none"> • Shut down • Retain last value 	Shut down	Device
Diagnostics: Wire break at outputs 0 to 7 (channels 0 to 7)	<ul style="list-style-type: none"> • Disable • Enable 	Disable	Channel
Diagnostics: Short circuit to M, outputs 0 to 7 (channels 0 to 7)	<ul style="list-style-type: none"> • Disable • Enable 	Disable	Channel

Parameters for 16 DO DC 24V/1,3A 8×M12 (6ES7142-6BH00-0AB0)

Parameter	Range of values	Default setting	Range of effectiveness
Group diagnostics	<ul style="list-style-type: none"> • Disable • Enable 	Disable	Device
Diagnostics: Missing 1L+ or 2L+	<ul style="list-style-type: none"> • Disable • Enable 	Disable	Channel group
Response to CPU/Master STOP	<ul style="list-style-type: none"> • Shut down • Retain last value 	Shut down	Device
Diagnostics: Wire break at outputs 0 to 15 (channels 0 to 15)	<ul style="list-style-type: none"> • Disable • Enable 	Disable	Channel
Diagnostics: Short circuit to M, outputs 0 to 15 (channels 0 to 15)	<ul style="list-style-type: none"> • Disable • Enable 	Disable	Channel

9.3 I/O device digital inputs/digital outputs

9.3.1 I/O device 8 DIO DC 24V/1.3A 8xM12

Article number

6ES7147-6BG00-0AB0

Properties

The 8 DIO DC 24V/1,3A 8xM12 I/O device has the following properties:

- 8 freely parameterizable digital inputs/outputs
- Prioritized startup
- Media redundancy
- Dimensions 60 x 175 mm, single assignment of the sockets
- Digital inputs
 - Rated input voltage DC 24 V
 - Suitable for switches and proximity switches
 - Diagnostics
 - "Missing 1L+ or 2L+" for the I/O device
 - "Short-circuit to M at sensor supply", per channel group
 - "Wire break", per channel
- Digital outputs
 - Rated load voltage DC 24 V
 - Output current: 1.3 A per output
 - Suitable for solenoid valves, DC contactors, and indicator lights
 - Diagnostics
 - "Missing 1L+ or 2L+" for the I/O device
 - "Wire break at outputs" per channel
 - "Short-circuit to M at outputs" per channel
 - Parameterizable response to CPU/Master STOP for I/O device

Pin assignment of the DIO sockets

The table below shows the pin assignment of the eight sockets for connecting digital inputs and digital outputs.

Table 9- 9 Pin assignment of sockets X1 to X8 for digital inputs/digital outputs

Pin	Assignment								View of socket (front view)
	Socket X1	Socket X2	Socket X3	Socket X4	Socket X5	Socket X6	Socket X7	Socket X8	
1	24 V sensor supply 1Us (derived from 1L+ non-switched)				24 V sensor supply 2Us (derived from 2L+ switched)				
2	Not used								
3	Supply ground 1M				Supply ground 2M				
4	Input/output signal								
	DIQ ₀	DIQ ₁	DIQ ₂	DIQ ₃	DIQ ₄	DIQ ₅	DIQ ₆	DIQ ₇	
5	Functional earth FE								

Block diagram

The block diagram below shows the 8 DIO DC 24V/1,3A 8×M12 I/O device.

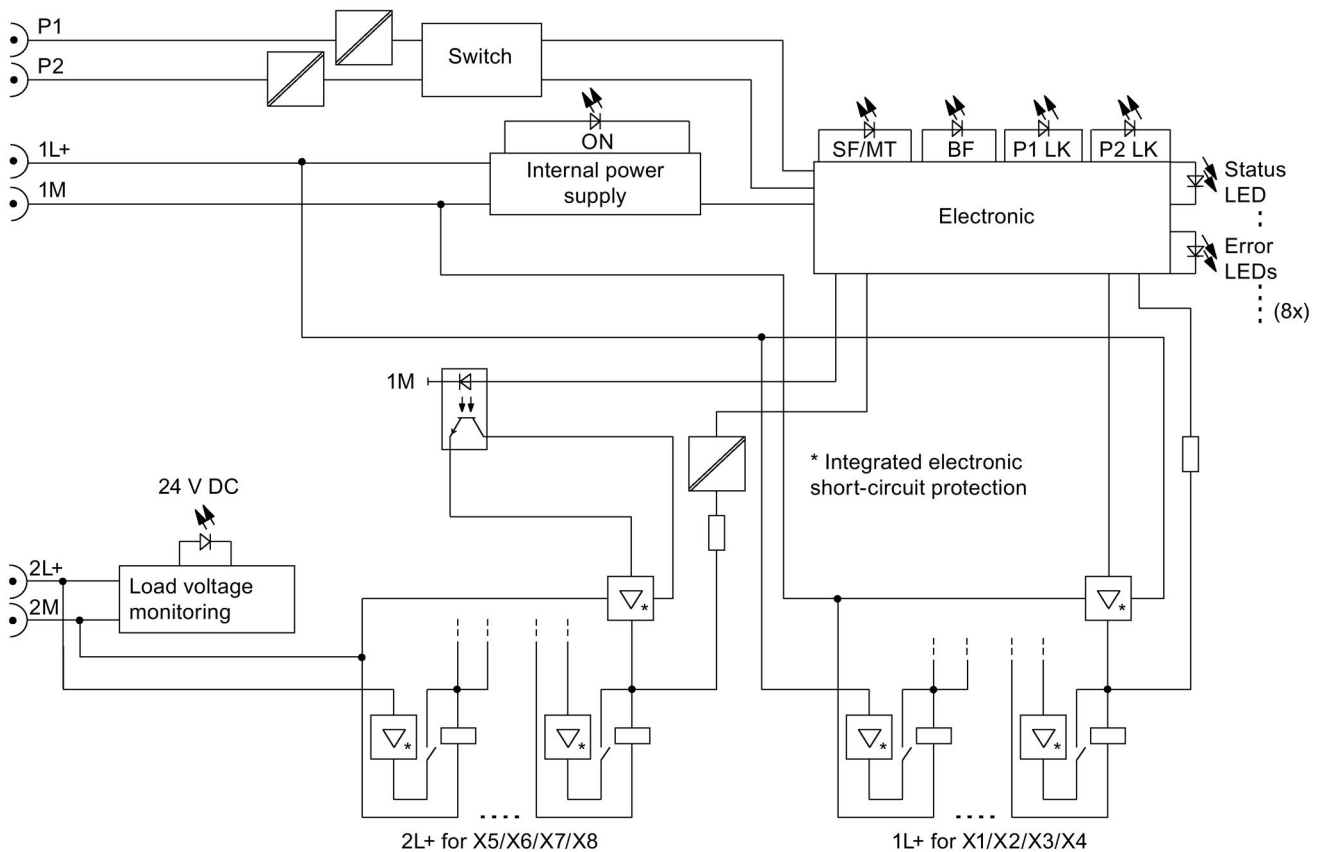

Figure 9-9 Block diagram of the 8 DIO DC 24V/1,3A 8×M12 I/O device

Technical data of the 8 DIO DC 24V/1,3A 8×M12 I/O device

Technical data	
Dimensions and weight	
Dimensions W x H x D (mm)	60 x 175 x 49
Weight	Approx. 910 g
Module-specific data	
Transmission rate	100 Mbps full duplex
Transmission mode	100BASE-TX
Autonegotiation	Yes
Bus protocol	PROFINET IO <ul style="list-style-type: none"> • IRT with the option "high flexibility" • IRT with the option "high performance"
Supported Ethernet services	PROFINET IO (Device) <ul style="list-style-type: none"> • ping • arp • LLDP • Network diagnostics (SNMP) • DCP • Prioritized startup • Media redundancy
PROFINET interface	
• Connection socket	2 x M12 d-coded
• Switch function	Yes, internal
• Auto-crossover	Yes, if autonegotiation is enabled
Manufacturer ID (Vendor ID)	002A _H
Device ID (DeviceID)	0306 _H
Voltages and currents	
Supply voltage 1L+	DC 24 V
• Reverse polarity protection	Yes, against destruction, loads are activated
• Infeed current 1L+	Max. 4 A
Supply voltage 2L+	DC 24 V
• Reverse polarity protection	Yes, against destruction, loads are activated
• Infeed current 2L+	Max. 4 A
Current consumption	
From supply voltage (1L+)	Typ. 100 mA (no digital output activated)
From supply voltage (2L+)	Typ. 5 mA (no digital output activated)
Power loss of the device	type 4.5 W (if all channels are set as digital input) type 6.5 W (if all channels are set as digital output)

Technical data	
Total current of the outputs	
<ul style="list-style-type: none"> All mounting positions to 60°C 	Max. 3.9 A per 1L+ and 2L+
Digital inputs/digital outputs	
Number of configurable inputs/outputs	8
Number of inputs that can be controlled simultaneously	8, in all mounting positions
Insulation	
Insulation test voltage	
<ul style="list-style-type: none"> Ethernet interface 	1500 V _{rms} (IEEE802.3)
<ul style="list-style-type: none"> All other circuit elements 	707 V DC (type test)
Electrical isolation	
<ul style="list-style-type: none"> Between 1L+ and 2L+ 	Yes
<ul style="list-style-type: none"> Between 1L+, channels and all other circuit elements 	No
<ul style="list-style-type: none"> Between channels 	No
<ul style="list-style-type: none"> Between Ethernet and all other circuit elements 	Yes
Status, interrupts, diagnostics	
Interrupts	Yes
Diagnostics function	Yes
<ul style="list-style-type: none"> Group error/maintenance 	Red/yellow "SF/MT" LED
<ul style="list-style-type: none"> Bus monitoring PROFINET IO 	Red "BF" LED
<ul style="list-style-type: none"> Monitoring of supply voltage 1L+ 	Green "ON" LED
<ul style="list-style-type: none"> Existing connection to network 	Green "P1 LK" and "P2 LK" LED; LED for PROFINET IO infeed and loop-through
<ul style="list-style-type: none"> Digital input 	Green LED
<ul style="list-style-type: none"> Fault at digital input 	Red LED
<ul style="list-style-type: none"> Digital output 	Green LED
<ul style="list-style-type: none"> Fault at digital output 	Red LED
<ul style="list-style-type: none"> Diagnostic information can be read 	Yes
Monitoring for	
<ul style="list-style-type: none"> Failure of 1L+ and 2L+ 	Yes
<ul style="list-style-type: none"> Sensor supply short-circuit 	Yes, per channel
<ul style="list-style-type: none"> Digital output short-circuit 	Yes, per channel
<ul style="list-style-type: none"> Digital input wire break 	Yes, input current < 0.3 mA, per channel
<ul style="list-style-type: none"> Digital output wire break 	Yes, in the off state, per channel

Technical data	
Sensor supply	
Number of sensor supplies	8, 4×1L+ and 4×2L+ Note: The sensor supply is only available when the corresponding channel is parameterized as an "Input".
Load current	100 mA per output
Short-circuit protection	Yes, electronic
Sensor selection data	
Cable length, shielded	Max. 30 m
Cable length, unshielded	Max. 30 m
Input voltage	
• Nominal value	24 V DC
• For signal "1"	11 to 30 V
• For signal "0"	-3 to +5 V
Input current	
• At signal "1"	Typ. 7 mA
Input delay	
• At "0" to "1"	Typ. 3 ms
• At "1" to "0"	Typ. 3 ms
Input characteristic	According to IEC 61131, Type 3
Connection of 2-wire proximity switches	
• Permitted quiescent current	Max. 1.5 mA
Actuator selection data	
Cable length, shielded	Max. 30 m
Cable length, unshielded	Max. 30 m
Output voltage	
• Nominal value	24 V DC
• For signal "1"	Min. 1L+/2L+ (-0.8 V)
Output current	
• At signal "1"	Max. 1.3 A
• For "0" signal (residual current)	Max. 1.5 mA
Load resistance range	22 Ω to 3.3 kΩ
Lamp load	Max. 5 W
Parallel wiring of two outputs	
• To increase performance	No
• For redundant control of a load	Supported
Control of a digital input	Yes

Technical data	
Switching frequency	
• With resistive load	Max. 100 Hz
• With inductive load	Max. 0.5 Hz
• With lamp load	Max. 1 Hz
Limiting of the inductive shutdown voltage to lamp load	Typ. 1L+/2L+ (-47 V)
Short-circuit protection of the output	Yes, electronic
• Response threshold	Typ. 1.8 A (per channel)

9.3.2 Parameter overview digital inputs/digital outputs

Parameters for 8 DIO DC 24V/1,3A 8×M12 (6ES7147-6BG00-0AB0)

Parameters	Range of values	Default setting	Range of effectiveness
Group diagnostics	<ul style="list-style-type: none"> • Disable • Enable 	Disable	Device
Diagnostics: Missing 1L+ or 2L+	<ul style="list-style-type: none"> • Disable • Enable 	Disable	Channel group
Diagnostics: Wire break at inputs 0 to 7 (channels 0 to 7)	<ul style="list-style-type: none"> • Disable • Enable 	Disable	Channel
Diagnostics: Short-circuit to M, inputs 0 to 7	<ul style="list-style-type: none"> • Disable • Enable 	Disable	Channel
Response to CPU/Master STOP	<ul style="list-style-type: none"> • Shut down • Retain last value 	Shut down	Device
Diagnostics: Wire break outputs 0 to 7	<ul style="list-style-type: none"> • Disable • Enable 	Disable	Channel
Diagnostics: Short-circuit to M, outputs 0 to 7	<ul style="list-style-type: none"> • Disable • Enable 	Disable	Channel
Freely parameterizable	<ul style="list-style-type: none"> • Digital input • Digital output 	Digital input	Channel

I/O device analog input/analog output

10.1 I/O device analog input

10.1.1 I/O device 8 AI 4 U/I + 4 RTD/TC 8xM12

Article number

6ES7144-6KD00-0AB0

Properties

- 4 inputs for voltage and current measurement (2-wire and 4-wire transducers)
- 4 inputs for resistance (2-/3-/4-wire transducer), thermal resistor (2-/3-/4-conductor connection system), thermocouple or ± 80 mV
- Input ranges:
 - ± 10 V, resolution 15 bits + sign
 - ± 80 mV, resolution 15 bps + sign
 - 0 to 10 V, resolution 15 bits
 - 1 to 5 V, resolution 15 bits
 - ± 20 mA, resolution 15 bits + sign
 - 0 to 20 mA, resolution 15 bps + sign
 - 4 to 20 mA, resolution 15 bits
 - 150, 300, 600, 3000 Ω , resolution 15 bps
 - Ni100, Ni1000, Ni120, Ni200, Ni500, Pt100, Pt1000, Pt200, Pt500, resolution 15 bps + sign
 - E, J, K, N, resolution 15 bps + sign
- Dimensions 60 x 175 mm
- Diagnostics
 - "Missing L1+" supply voltage
 - "Sensor supply short-circuit"
 - "Wire break"
 - "Underflow"
 - "Overflow"
- Permitted common-mode voltage AC 10V_{PP}
- Prioritized startup
- Media redundancy

Note

During startup

As long as no parameters are assigned for the I/O device, the I/O device supplies the process values 0x7FFF.

Pin assignment

The tables below show the pin assignment for the 8 AI 4 U/I + 4 RTD/TC 8×M12 I/O device.

Table 10- 1 Pin assignment for voltage and current for the 8 AI 4 U/I + 4 RTD/TC 8×M12 I/O device

Pin	Assignment for U/I				View of socket (front view)
	Socket X1 (Channel 0)	Socket X3 (Channel 1)	Socket X5 (Channel 2)	Socket X7 (Channel 3)	
1	24 V sensor supply 1Us(derived from 1L+ non-switched)				
2	Input signal				
	M ₀₊	M ₁₊	M ₂₊	M ₃₊	
3	Sensor supply ground 1M				
4	Input signal				
	M ₀₋	M ₁₋	M ₂₋	M ₃₋	
5	Functional earth FE				

10.1 I/O device analog input

Table 10- 2 Pin assignment for RTD for the 8 AI 4 U/I + 4 RTD/TC 8×M12 I/O device

Pin	Assignment for RTD				View of socket (front view)
	Socket X2 (Channel 4)	Socket X4 (Channel 5)	Socket X6 (Channel 6)	Socket X8 (Channel 7)	
4-conductor					
1	Constant current line				
	Ic4+	Ic5+	Ic6+	Ic7+	
2	Measurement cable				
	M4+	M5+	M6+	M7+	
3	Constant current line				
	Ic4-	Ic5-	Ic6-	Ic7-	
4	Measurement cable				
	M4-	M5-	M6-	M7-	
5	Functional earth FE				
3-conductor					
1	Constant current line				
	Ic4+	Ic5+	Ic6+	Ic7+	
2	Measurement cable				
	M4+	M5+	M6+	M7+	
3	Constant current line and measurement cable				
	Ic4-, M4-	Ic5-, M5-	Ic6-, M6-	Ic7-, M7-	
4	Not used				
5	Functional earth FE				
2-conductor					
1	Constant current line and measurement cable				
	Ic4+, M4+	Ic5+, M5+	Ic6+, M6+	Ic7+, M7+	
2	Not used				
3	Constant current line and measurement cable				
	Ic4-, M4-	Ic5-, M5-	Ic6-, M6-	Ic7-, M7-	
4	Not used				
5	Functional earth FE				

Table 10-3 Pin assignment for thermocouple and voltage ± 80 mV for 8 AI 4 U/I + 4 RTD/TC 8xM12 I/O device

Pin	Assignment for thermocouples and ± 80 mV				View of socket (front view)
	Socket X2 (Channel 4)	Socket X4 (Channel 5)	Socket X6 (Channel 6)	Socket X8 (Channel 7)	
1	Not used				
2	Input signal				
	M4+	M5+	M6+	M7+	
3	Not used				
4	Input signal				
	M4-	M5-	M6-	M7-	
5	Functional earth FE				

Block diagram

The block diagram below shows the 8 AI 4 U/I + 4 RTD/TC 8xM12.

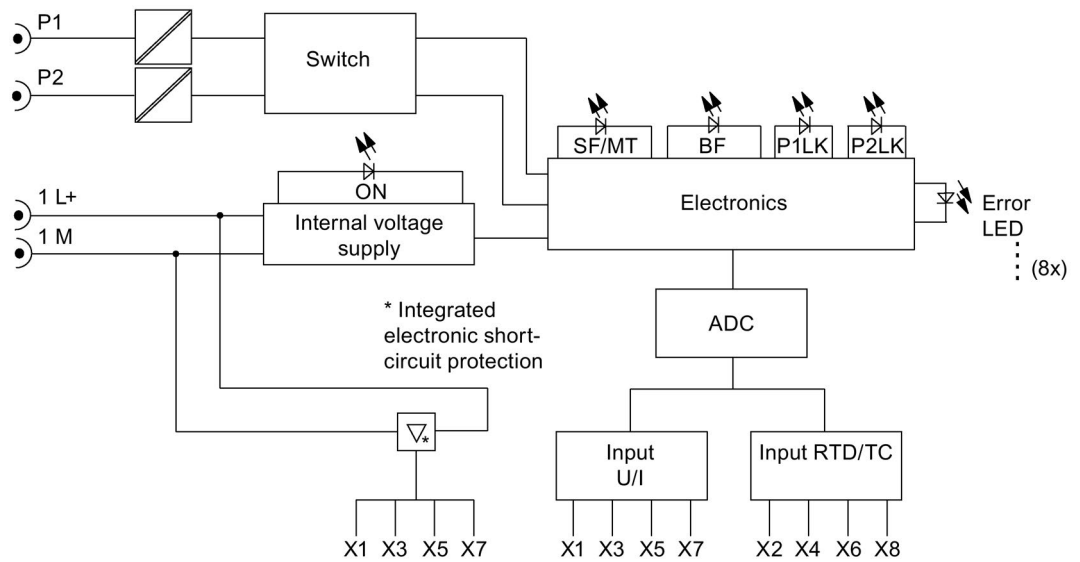

Figure 10-1 Block diagram 8 AI 4 U/I + 4 RTD/TC 8xM12

Technical data

Technical data	
Dimensions and weight	
Dimensions W x H x D (mm)	60 x 175 x 49
Weight	Approx. 930 g
Module-specific data	
Transmission rate	100 Mbps full duplex
Transmission mode	100BASE-TX
Autonegotiation	Yes
Bus protocol	PROFINET IO <ul style="list-style-type: none"> • IRT with the option "high flexibility" • IRT with the option "high performance"
Supported Ethernet services	PROFINET IO (Device) <ul style="list-style-type: none"> • ping • arp • LLDP • Network diagnostics (SNMP) • DCP • Prioritized startup • Media redundancy
PROFINET interface	
• Connection socket	2 x M12 d-coded
• Switch function	Yes, internal
• Auto-crossover	Yes; if autonegotiation is enabled
Manufacturer ID (Vendor ID)	002A _H
Device ID (DeviceID)	0306 _H
Voltages and currents	
Supply voltage 1L+	DC 24 V
Reverse polarity protection	Yes; against destruction
• Infeed current 1L+	Max. 4 A
Supply voltage 2L+	DC 24 V
• Infeed current 2L+	Max. 4 A
Current consumption	
• From supply voltage 1L+	Typ. 110 mA
• From supply voltage 2L+	0 mA
Power loss of the device	Typ. 2.8 W, without sensor current
Analog inputs	
Number of inputs	8 (4 for U or I, 4 for RTD or thermocouple)
Cable length, shielded	Max. 30 m

Technical data	
Sensor supply	
Number of sensor supplies	4
Total current	Max. 1 A
Short-circuit protection	Yes; electronic, for each module, to ground
• Response threshold	Min. 1.4 A
Sensor selection data	
Input ranges (Rated value)/input resistance or input voltage	
• Voltage	±80 mV/10 MΩ ±10 V/100 kΩ 0 to 10 V/100 kΩ 1 to 5 V/100 kΩ
• Current	±20 mA/17 V for 2-wire transducer, 3.5 V for 4-wire transducer 0 to 20 mA/17 V for 2-wire transducer, 3.5 V for 4-wire transducer 4 to 20 mA/17 V for 2-wire transducer, 3.5 V for 4-wire transducer
• Resistor and thermal resistor	150 Ω/10 MΩ 300 Ω/10 MΩ 600 Ω/10 MΩ 3000 Ω/10 MΩ Ni100/10 MΩ Ni1000/10 MΩ Ni120/10 MΩ Ni200/10 MΩ Ni500/10 MΩ Pt100/10 MΩ Pt1000/10 MΩ Pt200/10 MΩ Pt500/10 MΩ
• Thermocouple	Types E, J, K, N
Permitted input voltage for voltage input (destruction limit)	28.8 V continuous, 35 V for max. duration of 500 ms
Connection of sensors for voltage measurement	Yes
Connection of sensors for current measurement	Yes (as 2-wire/4-wire transducer)
Connection of sensors for RTD	Yes (with 2-/3-/4-conductor connection)
Connection of sensors for thermocouples	Yes
Temperature compensation for thermocouples ¹	
• Internal temperature compensation	Yes, parameterizable
• External temperature compensation	Yes, parameterizable
Technical unit for temperature measurement	°C, °F, K

Technical data					
Formation of analog values					
Measuring principle		Integrating			
Integration time and conversion time/resolution (per channel)					
• Integration time parameterizable		Yes			
• Interference frequency suppression in Hz		500/60/50/10			
• Integration time in ms		2.0/16.667/20/100			
• Conversion time in ms (per channel) ²		4/19/22/102			
• Resolution for voltage (including overrange)		±80 mV/15 bps + sign ±10 V/15 bps + sign 0 to 10 V/15 bps 1 to 5 V/15 bps			
• Resolution for current (including overrange)		±20 mA/15 bps + sign 0 to 20 mA/15 bps 4 to 20 mA/15 bps			
• Resolution for RTD (including overrange)		150 Ω, 300 Ω, 600 Ω, 3000 Ω/15 bps, Ni100, Ni1000, Ni120, Ni200; Ni500, Pt100, Pt1000, Pt200, Pt500/15 bps + sign			
• Resolution for thermocouples (including overrange)		Types E, J, K, N/15 bps + sign			
Measured value smoothing		Yes, parameterizable in 4 levels			
	Level None Weak Medium Strong	Time constant 1 x cycle time 4 x cycle time 16 x cycle time 64 x cycle time			
Interference suppression, error limits					
Interference suppression for $f = n \times (f_1 \pm 0.5\%)$, ($f_1 =$ interference frequency)		46 dB			
• Common-mode interference (interference voltage < 5 V)		70 dB			
• Series-mode interference (peak value of interference < Rated value of input range)		46 dB			
Crosstalk between inputs		< -85 dB			
Operational limit (across temperature range, relative to input range)		Ambient temperature			
		positive	negative (0 °C to -25 °C)	negative (-25 °C to -40 °C)	
		U	0.15%	0.2%	0.35%
		I	0.2%	0.25%	0.4%
		R, RTD	0.1%	0.15%	0.3%
TC	0.2%	0.25%	0.4%		

Technical data			
Basic error limit (operational limit at 25 °C, relative to input range) ³	U	0.1%	
	I	0.1%	
	R, RTD	0.05%	
	TC	0.1%	
Temperature error (relative to input range)	Ambient temperature		
		positive	negative
	U	0.0035%/K	0.007%/K
	I	0.006%/K	0.007%/K
	R, RTD	0.0005%/K	0.001%/K
	TC	0.0035%/K	0.007%/K
Linearity error (relative to input range)	±0.01%		
Repeat accuracy (in steady-state condition at 25°C, relative to input range)	±0.008%		
Operational limit for internal temperature sensor	±3 °C		
Basic error limit for internal temperature sensor	±2 °C		
Status, interrupts, diagnostics			
Interrupts	Yes		
Diagnostics functions			
• Group error/maintenance	Red/yellow "SF/MT" LED		
• Bus monitoring PROFINET IO	Red "BF" LED		
• Monitoring of supply voltage 1L+	Green "ON" LED		
• Existing connection to bus	Green "P1 LK" and "P2 LK" LED; LED for PROFINET IO infeed and loop-through		
• Analog input error	Red LED		
• Diagnostic information can be read	Yes		
Monitoring for			
• Sensor supply short-circuit	Yes, only if channel is enabled		
• Wire break	4 to 20 mA, 1 to 5 V, resistors and thermoresistors		
• Underflow and overflow	Yes		
• Supply voltage 1L+	Yes		
Insulation			
Insulation test voltage			
• Ethernet interface	1500 V _{rms} (IEEE802.3)		
• All other circuit elements	707 V DC (type test)		

Technical data	
Electrical isolation	
• Between 1L+ and 2L+	Yes
• Between 1L+, channels and all other circuit elements	No
• Between channels	No
• Between Ethernet and all other circuit elements	Yes
<p>¹ "No temperature compensation" is always run when using the measuring type ± 80 mV regardless of the configured temperature compensation.</p> <p>² With 3-wire resistance measurement (and thermal resistor) the measuring resistances and the line resistances are updated in alternating cycles. Rapid changes in the measuring resistance therefore impair the accuracy.</p> <p>³ For thermocouples, the information refers to the temperature range from -100 °C to nominal value</p>	

Note

The accuracy information is valid for static thermal states and changes in ambient temperature < 1 K/h.

The I/O device achieves the highest accuracy with the 4-wire connection system (see technical specifications above).

Although the 3-wire connection system compensates for the missing wire, the accuracy is impaired. With the 2-wire connection system, the line resistances considerably impair the accuracy.

In the last two cases this impairment is not determinable.

Note

With the 3-wire connection system, the compensation of the missing cable is only ensured if all three cores in the cable have the same length and cross-section.

See also

Response times for analog input device and output device (Page 258)

10.1.2 8 AI RTD/TC 8×M12 I/O device

Article number

6ES7144-6KD50-0AB0

Properties

The electronic module 8 AI RTD/TC 8×M12 has the properties listed below:

- 8 freely parameterizable inputs:
 - Resistance (2-/3-/4-wire transmitter)
 - Thermoresistor (2-/3-/4-conductor connection system)
 - Thermocouple or ± 80 mV
- Input ranges:
 - Voltage measurement: ± 80 mV; resolution 15 bit + sign
 - Resistance measurement: 150 Ω , 300 Ω , 600 Ω , 3000 Ω ; resolution 15 bits
 - Resistance thermometer: Pt100, Ni100, Ni120, Pt200, Ni200, Pt500, Ni500, Pt1000, Ni1000; resolution 15 bits + sign
 - Thermocouple elements: E, J, K, N; resolution 15 bits + sign
- Dimensions 60 x 175 mm
- Diagnostics
 - "Missing L1+" supply voltage
 - "Wire break"
 - "Underflow"
 - "Overflow"
- Permitted common-mode voltage AC 10V_{PP}
- Prioritized startup
- Media redundancy

Note

During startup

As long as no parameters are assigned for the I/O device, the I/O device supplies the process values 7FFF_H.

Pin assignment

The tables below show the pin assignment for the 8 AI RTD/TC 8xM12 electronic module.

Table 10- 4 Pin assignment for RTD for the 8 AI RTD/TC 8xM12 electronic module

Pin	Assignment for RTD								View of socket (front view)
	Socket X1 (Channel 0)	Socket X2 (Channel 4)	Socket X3 (Channel 1)	Socket X4 (Channel 5)	Socket X5 (Channel 2)	Socket X6 (Channel 6)	Socket X7 (Channel 3)	Socket X8 (Channel 7)	
4-conductor									
1	Constant current line								
	Ic0+	Ic4+	Ic1+	Ic5+	Ic2+	Ic6+	Ic3+	Ic7+	
2	Measurement cable								
	M0+	M4+	M1+	M5+	M2+	M6+	M3+	M7+	
3	Constant current line								
	Ic0-	Ic4-	Ic1-	Ic5-	Ic2-	Ic6-	Ic3-	Ic7-	
4	Measurement cable								
	M0-	M4-	M1-	M5-	M2-	M6-	M3-	M7-	
5	Functional earth FE								
3-conductor									
1	Constant current line								
	Ic0+	Ic4+	Ic1+	Ic5+	Ic2+	Ic6+	Ic3+	Ic7+	
2	Measurement cable								
	M0+	M4+	M1+	M5+	M2+	M6+	M3+	M7+	
3	Constant current line and measurement cable								
	Ic0-, M0-	Ic4-, M4-	Ic1-, M1-	Ic5-, M5-	Ic2-, M2-	Ic6-, M6-	Ic3-, M3-	Ic7-, M7-	
4	Not used								
5	Functional earth FE								
2-conductor									
1	Constant current line and measurement cable								
	Ic0+, M0+	Ic4+, M4+	Ic1+, M1+	Ic5+, M5+	Ic2+, M2+	Ic6+, M6+	Ic3+, M3+	Ic7+, M7+	
2	Not used								
3	Constant current line and measurement cable								
	Ic0-, M0-	Ic4-, M4-	Ic1-, M1-	Ic5-, M5-	Ic2-, M2-	Ic6-, M6-	Ic3-, M3-	Ic7-, M7-	
4	Not used								
5	Functional earth FE								

Table 10-5 Pin assignment for thermocouples with 8 AI RTD/TC 8xM12 electronic module

Pin	Assignment for thermocouples and ± 80 mV								View of socket (front view)
	Socket X1 (Channel 0)	Socket X2 (Channel 4)	Socket X3 (Channel 1)	Socket X4 (Channel 5)	Socket X5 (Channel 2)	Socket X6 (Channel 6)	Socket X7 (Channel 3)	Socket X8 (Channel 7)	
1	Not used								
2	Input signal								
	M ₀₊	M ₄₊	M ₁₊	M ₅₊	M ₂₊	M ₆₊	M ₃₊	M ₇₊	
3	Not used								
4	Input signal								
	M ₀₋	M ₄₋	M ₁₋	M ₅₋	M ₂₋	M ₆₋	M ₃₋	M ₇₋	
5	Functional earth FE								

Block diagram

The figure below shows the block diagram of the 8 AI RTD/TC 8xM12 electronic module.

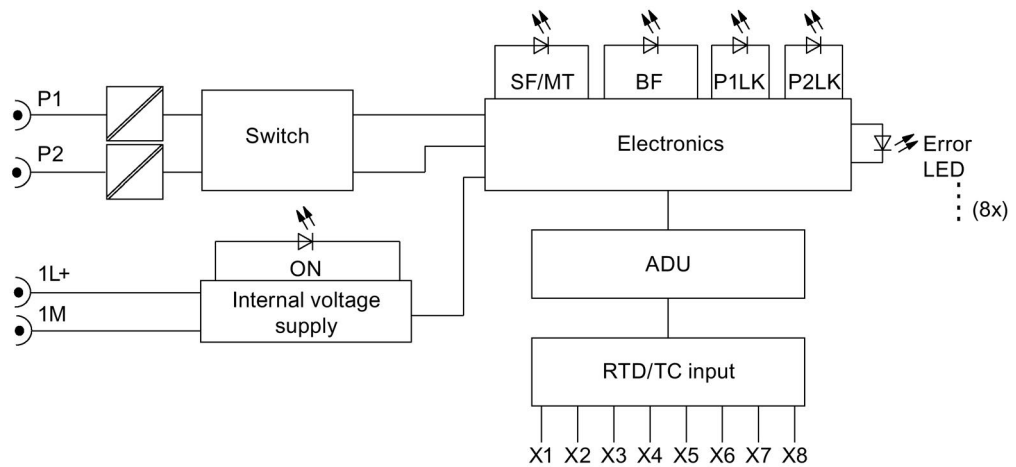

Figure 10-2 Block diagram 8 AI RTD/TC 8xM12

Technical data

Technical data	
Dimensions and weight	
Dimensions W x H x D (mm)	60 x 175 x 49
Weight	Approx. 930 g
Module-specific data	
Transmission rate	100 Mbps full duplex
Transmission mode	100 BASE-TX
Autonegotiation	Yes
Bus protocol	PROFINET IO <ul style="list-style-type: none"> • IRT with the option "high flexibility" • IRT with the option "high performance"
Supported Ethernet services	PROFINET IO (Device) <ul style="list-style-type: none"> • ping • arp • LLDP • Network diagnostics (SNMP) • DCP • Prioritized startup • Media redundancy
PROFINET interface	
• Connection socket	2 x M12 d-coded
• Switch function	Yes, internal
• Auto-crossover	Yes; if autonegotiation is enabled
Manufacturer ID (Vendor ID)	002A _H
Device ID (DeviceID)	0306 _H
Voltages and currents	
Supply voltage 1L+	DC 24 V
Reverse polarity protection	Yes; against destruction
• Infeed current 1L+	Max. 4 A
Supply voltage 2L+	DC 24 V
• Infeed current 2L+	Max. 4 A
Current consumption	
• From supply voltage 1L+	Typ. 110 mA
• From supply voltage 2L+	0 mA
Power loss of the device	Typ. 2.8 W, without sensor current
Analog inputs	
Number of inputs	8, for RTD or thermocouple
Cable length, shielded	Max. 30 m

Technical data	
Sensor selection data	
Input ranges (Rated value)/input resistance or input voltage	
• Voltage	±80 mV
• Resistance	150 Ω/10 MΩ 300 Ω/10 MΩ 600 Ω/10 MΩ 3000 Ω/10 MΩ
• Thermoresistor	Pt100/10 MΩ Pt200/10 MΩ Pt500/10 MΩ Pt1000/10 MΩ Ni100/10 MΩ Ni120/10 MΩ Ni200/10 MΩ Ni500/10 MΩ Ni1000/10 MΩ
• Thermocouple	Types N, E, J, K
Permitted input voltage for voltage input (destruction limit)	28.8 V continuous, 35 V for max. duration of 500 ms
Connection of sensors for RTD	Yes (with 2-/3-/4-conductor connection)
Connection of sensors for thermocouples	Yes
Temperature compensation ¹	
• None	Yes, parameterizable
• Internal	Yes, parameterizable
• RTD (0)	Yes, parameterizable
• Dynamic reference temperature	Yes, parameterizable
• Fixed reference temperature	Yes, parameterizable
Technical unit for temperature measurement	°C, °F, K
Formation of analog values	
Measuring principle	Integrating
Integration time and conversion time/resolution (per channel)	
• Integration time parameterizable	Yes
• Interference frequency suppression in Hz	500/60/50/10
• Integration time in ms	2.0/16.667/20/100
• Conversion time in ms (per channel) ²	4/19/22/102
• Resolution for RTD (including overrange)	150 Ω, 300 Ω, 600 Ω, 3000 Ω/15 bits Pt100, Pt200, Pt500, Pt1000, Ni100, Ni120, Ni200, Ni500, Ni1000/15 bits + sign
• Resolution for thermocouples (including overrange)	Types N, E, J, K/15 bits + sign

Technical data					
Measured value smoothing		Yes, parameterizable in 4 levels			
	Level None Weak Medium Strong	Time constant 1 x cycle time 4 x cycle time 16 x cycle time 64 x cycle time			
Interference suppression, error limits					
Interference suppression for $f = n \times (f_1 \pm 0.5\%)$, ($f_1 =$ interference frequency)		46 dB			
<ul style="list-style-type: none"> Common-mode interference (interference voltage < 5 V) 		70 dB			
<ul style="list-style-type: none"> Series-mode interference (peak value of interference < Rated value of input range) 		46 dB			
Crosstalk between inputs		< -85 dB			
Operational limit (across temperature range, relative to input range)		Ambient temperature			
		positive	negative (0 °C to -25 °C)	negative (-25 °C to -40 °C)	
		R, RTD	0.1%	0.15%	0.3%
		TC	0.2%	0.25%	0.4%
Basic error limit (operational limit at 25 °C, relative to input range) ³		R, RTD	0.05%		
		TC	0.1%		
Temperature error (relative to input range)		Ambient temperature			
		positive	negative		
		R, RTD	0.0005%/K	0.001%/K	
		TC	0.0035%/K	0.007%/K	
Linearity error (relative to input range)		±0.01%			
Repeat accuracy (in steady-state condition at 25°C, relative to input range)		±0.008%			
Operational limits (relative to internal temperature sensor)		±3 °C			
Basic error limits (relative to internal temperature sensor)		±2 °C			
Status, interrupts, diagnostics					
Interrupts		Yes			
Diagnostics functions					
<ul style="list-style-type: none"> Group error/maintenance 		Red/yellow "SF/MT" LED			
<ul style="list-style-type: none"> Bus monitoring PROFINET IO 		Red "BF" LED			
<ul style="list-style-type: none"> Monitoring of supply voltage 1L+ 		Green "ON" LED			
<ul style="list-style-type: none"> Existing connection to bus 		Green "P1 LK" and "P2 LK" LED; LED for PROFINET IO infeed and loop-through			
<ul style="list-style-type: none"> Analog input error 		Red LED			
<ul style="list-style-type: none"> Diagnostic information can be read 		Yes			

Technical data	
Monitoring for	
• Wire break	Resistors and thermoresistors
• Underflow and overflow	Yes
• Supply voltage 1L+	Yes
Insulation	
Insulation test voltage	
• Ethernet interface	1500 V _{rms} (IEEE802.3)
• All other circuit elements	707 V DC (type test)
Electrical isolation	
• Between 1L+ and 2L+	Yes
• Between 1L+, channels and all other circuit elements	No
• Between channels	No
• Between Ethernet and all other circuit elements	Yes
<p>¹ "No temperature compensation" is always run when using the measuring type ± 80 mV regardless of the configured temperature compensation.</p> <p>² With 3-wire resistance measurement (and thermal resistor) the measuring resistances and the line resistances are updated in alternating cycles. Rapid changes in the measuring resistance therefore impair the accuracy.</p> <p>³ For thermocouples, the information refers to the temperature range from -100 °C to nominal value.</p>	

Note

The accuracy information is valid for static thermal states and changes in ambient temperature < 1 K/h.

The I/O device achieves the highest accuracy with the 4-wire connection system (see technical specifications above).

Although the 3-wire connection system compensates for the missing wire, the accuracy is impaired. With the 2-wire connection system, the line resistances considerably impair the accuracy.

In the last two cases this impairment is not determinable.

Note

With the 3-wire connection system, the compensation of the missing cable is only ensured if all three cores in the cable have the same length and cross-section.

10.1.3 Parameter overview analog input

Parameters for analog input 8 AI 4 U/I + 4 RTD/TC 8xM12 (6ES7144-6KD00-0AB0)

Parameters	Range of values	Default setting	Range of effectiveness
Group diagnostics	<ul style="list-style-type: none"> • Disable • Enable 	Disable	Device
Diagnostics, missing 1L+	<ul style="list-style-type: none"> • Disable • Enable 	Disable	Device
Diagnostics, sensor supply short-circuit	<ul style="list-style-type: none"> • Disable • Enable 	Disable	Device
Interference frequency suppression	<ul style="list-style-type: none"> • OFF • 60 Hz • 50 Hz • 10 Hz 	50 Hz	Device
Temperature unit	<ul style="list-style-type: none"> • Celsius • Fahrenheit • Kelvin 	Celsius	Channel groups 4 to 7
Reference temperature for TC	<ul style="list-style-type: none"> • -145.0 to 155.0 (Celsius) • -229.0 to 311.0 (Fahrenheit) • 128.2 to 428.2 (Kelvin) 	0.0	Device
Measurement type, channels 0 to 3	<ul style="list-style-type: none"> • Disabled • Voltage • Current (4-wire transducer) • Current (2-wire transducer) 	Voltage	Channel
Measurement type, channels 4 to 7	<ul style="list-style-type: none"> • Disabled • Resistance (4-wire connection) • Resistance (3-wire connection) • Resistance (2-wire connection) • Thermoresistor (linear, 4-conductor connection) • Thermoresistor (linear, 3-conductor connection) • Thermoresistor (linear, 2-conductor connection) • Thermocouple elements • Voltage +/-80 mV 	Thermoresistor Pt100 (4-conductor connection)	Channel

Parameters	Range of values	Default setting	Range of effectiveness
Measurement range, channels 0 to 3	<ul style="list-style-type: none"> • 1 to 5 V • 0 to 10 V • +/-10 V • 0 to 20 mA • 4 to 20 mA • ±20 mA 	±10 V	Channel
Measuring range, channels 4 to 7	<ul style="list-style-type: none"> • +/-80 mV • 150 Ω • 300 Ω • 600 Ω • 3000 Ω • Pt100 Climatic range • Pt100 Standard range • Pt200 Climatic range • Pt200 Standard range • Pt500 Climatic range • Pt500 Standard range • Pt1000 Climatic range • Pt1000 Standard range • Ni100 Climatic range • Ni100 Standard range • Ni120 Climatic range • Ni120 Standard range • Ni200 Climatic range • Ni200 Standard range • Ni500 Climatic range • Ni500 Standard range • Ni1000 Climatic range • Ni1000 Standard range • TC_EL Typ_N_[NiCrSi_NiSi] • TC_EL Typ_E_[NiCr_CuNi] • TC_EL Typ_J_[Fe_CuNi] • TC_EL Typ_K_[NiCr_Ni] 	Pt100 Standard range	Channel
Reference junction for thermoresistor (TC)	<ul style="list-style-type: none"> • Internal • External 	Internal	Channel

10.1 I/O device analog input

Parameters	Range of values	Default setting	Range of effectiveness
Temperature coefficient	<ul style="list-style-type: none"> • Pt 0.003916 • Pt 0.003902 • Pt 0.00392 • Pt 0.003851¹ • Ni 0.00618 • Ni 0.00672 • Ni 0.005000 	Pt 0.003851 ¹	Channel
Smoothing	<ul style="list-style-type: none"> • None • Weak • Medium • Strong 	None	Channel
Diagnostics, wire break	<ul style="list-style-type: none"> • Disable • Enable 	Disable	Channel
Diagnostics, underflow	<ul style="list-style-type: none"> • Disable • Enable 	Disable	Channel
Diagnostics, overflow	<ul style="list-style-type: none"> • Disable • Enable 	Disable	Channel

¹This value can also be shown as $\alpha = 0.00385055$ in the parameter assignment.

Parameters for analog input 8 AI RTD/TC 8xM12 (6ES7144-6KD50-0AB0)

Parameters	Range of values	Default setting	Range of effectiveness
Group diagnostics	<ul style="list-style-type: none"> • Disable • Enable 	Disable	Device
Diagnostics, missing 1L+	<ul style="list-style-type: none"> • Disable • Enable 	Disable	Device
Interference frequency suppression	<ul style="list-style-type: none"> • OFF • 60 Hz • 50 Hz • 10 Hz 	50 Hz	Device
Temperature unit	<ul style="list-style-type: none"> • Celsius • Fahrenheit • Kelvin 	Celsius	Device
Reference temperature for TC	<ul style="list-style-type: none"> • -145.0 to 155.0 (Celsius) • -229.0 to 311.0 (Fahrenheit) • 128.2 to 428.2 (Kelvin) 	0.0	Device
Measurement type, channels 0 to 7	<ul style="list-style-type: none"> • Disabled • Voltage +/-80 mV • Resistance (4-wire connection) • Resistance (3-wire connection) • Resistance (2-wire connection) • Thermoresistor (linear, 4-conductor connection) • Thermoresistor (linear, 3-conductor connection) • Thermoresistor (linear, 2-conductor connection) • Thermocouple elements 	Thermoresistor Pt100 (4-conductor connection)	Channel

10.1 I/O device analog input

Parameters	Range of values	Default setting	Range of effectiveness
Measuring range, channels 0 to 7	<ul style="list-style-type: none"> • +/-80 mV • 150 Ω • 300 Ω • 600 Ω • 3000 Ω • Pt100 Climatic range • Pt100 Standard range • Pt200 Climatic range • Pt200 Standard range • Pt500 Climatic range • Pt500 Standard range • Pt1000 Climatic range • Pt1000 Standard range • Ni100 Climatic range • Ni100 Standard range • Ni120 Climatic range • Ni120 Standard range • Ni200 Climatic range • Ni200 Standard range • Ni500 Climatic range • Ni500 Standard range • Ni1000 Climatic range • Ni1000 Standard range • TC_EL Typ_N_[NiCrSi_NiSi] • TC_EL Typ_E_[NiCr_CuNi] • TC_EL Typ_J_[Fe_CuNi] • TC_EL Typ_K_[NiCr_Ni] 	Pt100 Standard range	Channel
Reference junction for thermoresistor (TC)	<ul style="list-style-type: none"> • None • Internal • RTD (0) • Dynamic Ref. Temp. • Fix Ref. Temp. 	Internal	Channel
Temperature coefficient	<ul style="list-style-type: none"> • Pt 0.003916 • Pt 0.003902 • Pt 0.00392 • Pt 0.003851¹ • Ni 0.00618 • Ni 0.00672 • Ni 0.005000 	Pt 0.003851 ¹	Channel

Parameters	Range of values	Default setting	Range of effectiveness
Smoothing	<ul style="list-style-type: none"> • None • Weak • Medium • Strong 	None	Channel
Diagnostics, wire break	<ul style="list-style-type: none"> • Disable • Enable 	Disable	Channel
Diagnostics, underflow	<ul style="list-style-type: none"> • Disable • Enable 	Disable	Channel
Diagnostics, overflow	<ul style="list-style-type: none"> • Disable • Enable 	Disable	Channel

¹This value can also be shown as $\alpha = 0.00385055$ in the parameter assignment.

Measuring type with 8 AI RTD

The following table lists the temperature coefficients and measuring ranges you can assign for each measurement type:

Measurement type	Temperature coefficient	Measuring range
Thermoresistor 4-conductor Thermoresistor 3-conductor Thermoresistor 2-conductor	Pt 0.00385 ^{1, 2/} Pt 0.003916/ Pt 0.003902/ Pt 0.003920	Pt100 Climatic range / Pt100 Standard range / Pt200 Climatic range / Pt200 Standard range / Pt500 Climatic range / Pt500 Standard range / Pt1000 Climatic range / Pt1000 Standard range
	Ni 0.006180 ^{1/} Ni 0.006720/ Ni 0.005 ³	Ni100 Climatic range / Ni100 Standard range / Ni120 Climatic range / Ni120 Standard range / Ni200 Climatic range / Ni200 Standard range / Ni500 Climatic range / Ni500 Standard range / Ni1000 Climatic range / Ni1000 Standard range

¹ The default settings for the temperature coefficients apply according to the standard EN60751.
²This value can also be shown as $\alpha = 0.00385055$ in the parameter assignment.
³ The thermoresistor LG-Ni1000 corresponds to the thermoresistor Ni1000 with the temperature coefficient 0.005

Note

For a thermoresistor, the climatic type is only possible with temperature units Celsius (°C) and Fahrenheit (°F).

10.1.4 Parameter description analog input

Group diagnostics

You can generally enable and disable the diagnostics function of the device with this parameter.

The "Fault" and "Parameter assignment error" diagnostics functions are always independent of the group diagnostics.

Diagnostics: Missing 1L+

If you enable this parameter, the check for missing supply voltage is enabled.

Diagnostics: Short-circuit sensor supply

If you enable this parameter, a diagnostics event is generated if a short-circuit of the sensor supply to ground is detected and the channel is enabled. The sensor supply is monitored for connectors X1, X3, X5, and X7. No differentiation is made as to the connector where the sensor short-circuit occurred.

Interference frequency suppression

With this parameter, you set the integration time of the device, based on the selected interference frequency. Select the frequency of the supply voltage used. Interference frequency suppression "Off" means 500 Hz, which corresponds to an integration time of 2 ms for a measurement channel.

Temperature unit

This parameter is used to select the unit in which the temperature is detected.

Reference temperature for TC

The reference temperature applies for all channels at which "Reference junction" "Fix Ref. Temp." was selected. Information about the value range of the reference temperature is available in the table Reference temperature for TC (Page 192).

Measurement type (channel-wise)

Click the field to have the available measurement types displayed and select them.

Possible measurement types:

- Voltage ± 80 mV
- Resistor (4-wire connection)
- Resistor (3-wire connection)
- Resistor (2-wire connection)
- Thermal resistor (linear, 4-wire connection)
- Thermal resistor (linear, 3-wire connection)
- Thermal resistor (linear, 2-wire connection)
- Thermocouple

With this parameter, you set the measurement type, for example, voltage. For any unused channels, you must select the **disabled** setting. For a disabled channel, the conversion time and integration time of the channel = 0 s, and the overall cycle time of the device is reduced.

Measuring range

With this parameter, you set the measuring range of the selected measurement type.

Temperature coefficient (for RTD, thermoresistor)

The correction factor for the temperature coefficient (α -value) specifies the extent to which the resistance of a certain material changes when the temperature is raised by 1 °C.

The α -values conform to EN 60751, GOST 6651, JIS C 1604, and ASTM E-1137.

The temperature coefficient depends on the chemical composition of the material.

Smoothing

Smoothing of the analog values produces a stable analog signal for further processing. The smoothing of analog values is useful when handling wanted signals (measured values) with a slow rate of change, for example, temperature measurements.

The measured values are smoothed by digital filtering. To achieve smoothing, the device generates a mean value from a specified number of converted (digitized) analog values.

You assign a maximum of four levels for the smoothing (none, weak, medium, strong). The level determines the number of module cycles, from which the mean value is generated.

The stronger the smoothing, the more precisely the smoothed analog value reaches the setpoint value. The time interval until the smoothed analog value is applied after a signal change is also prolonged.

The figure below shows the number of cycles a module requires to apply the smoothed analog value at almost 100% after a step response, based on the smoothing function settings. The figure applies to all signal changes at the analog input. The smoothing value defines the number of cycles a module requires to reach 63% of the end value of the changed signal.

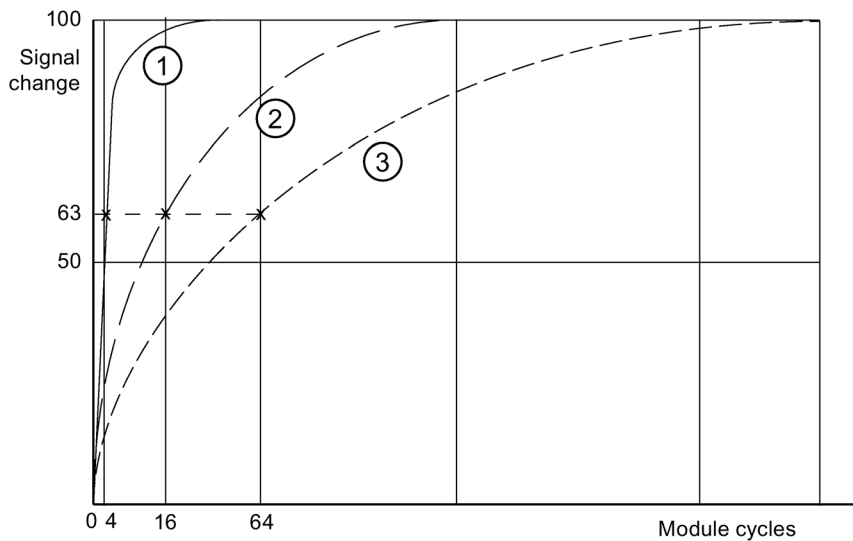

- ① Smoothing, weak
- ② Smoothing, medium
- ③ Smoothing, strong

Diagnostics: Wire break

When this parameter is enabled, the **Wire break** diagnostics event is generated when a wire break is detected.

Observe the rules outlined below to handle a wire break in the 1 V to 5 V and 4 mA to 20 mA measuring ranges:

Parameters	Event	Measured value	Explanation
Enable wire break ¹	Wire break	7FFF _H	Diagnostics, wire break
Wire break disabled ¹ Underflow enabled	Wire break	8000 _H	Measured value after leaving the under-shoot range Diagnostic message Lower limit value undershot
Wire break disabled ¹ Underflow disabled	Wire break	8000 _H	Measured value after leaving the under-shoot range
¹ Measuring range limits for wire break detection and measuring range undershoot detection: <ul style="list-style-type: none"> • 1 V to 5 V: At 0.296 V • 4 mA to 20 mA: At 1.185 mA 			

Diagnostics at 8AI RTD/TC

Take the following diagnostics into account:

Diagnostics, wire break	Diagnostics, overflow	Diagnostics, underflow	Event	Process data	Diagnostic message per channel
Activated	Deactivated	Deactivated	Wire break	0x7FFF	Wire break
Deactivated	Deactivated	Activated	Wire break	0x8000	Low limit violated
Deactivated	Activated	Deactivated	Wire break	0x7FFF	High limit violated
Deactivated	Activated	Activated	Wire break	0x8000	Low limit violated
Deactivated	Deactivated	Deactivated	Wire break	0x7FFF	

Diagnostics: Underflow

If the measured value reaches the underflow range and you enable this parameter, the **Underflow** diagnostics event is generated.

Diagnostics: Overflow

If the measured value reaches the overflow range and you enable this parameter, the **Overflow** diagnostics event is generated.

Reference junction for thermoresistor (TC)

A difference in temperature between the measuring point and the free ends of the thermocouple (terminal point) generates a voltage between the free ends, namely the thermoelectric voltage. The value of this thermoelectric voltage is determined by the temperature difference between the measuring point and the free ends, and by the type of material combination of the thermocouple. Since a thermocouple always measures a temperature difference, the free ends at the reference junction must be maintained at a known temperature in order to determine the temperature of the measuring point.

In the case of the I/O device 8 AI 4 U/I + 4 RTD/TC 8xM12 and 8 AI RTD/TC 8xM12, the following compensation settings are possible:

- No / external compensation: The reference junction temperature is measured outside the module, e.g., via a compensation slot.

With this compensation type, the reference junction temperature of the thermocouples is measured outside the two I/O devices. For this purpose you can, for example, connect a compensation slot to the thermocouple.

With this compensation type, the temperature of the reference junction is specified at 0 °C .

The temperature of 0 °C is reached when a compensation slot is used. One compensation slot is required per thermocouple.

- Internal: The temperature of the measuring point is measured in the housing of the I/O device.

With this type of compensation the reference junction temperature is determined with an internal temperature sensor. One temperature sensor is integrated into each I/O device.

The reference junction temperature is detected by an internal temperature sensor.

The same reference junction temperature is assigned to all the channels of the I/O devices that you selected for this type of compensation.

With the I/O device 8 AI RTD/TC 8xM12, the following compensation settings are also possible :

- RTD (0): The reference junction temperature is determined by means of a thermal resistor (Pt1000).

With this compensation the reference junction temperature is determined by measuring the resistance value of a Pt1000 at the terminal point of the M12 compensation connector. The resistance measurement may only be carried out on the round socket X1 (Channel 0).

The reference junction temperature is determined by the resistance value Pt1000.

The same reference junction temperature is assigned to all the channels of the I/O device 8 AI RTD/TC 8xM12 that you selected for this type of compensation.

The cycle time increases by 1 x the conversion time.

If the compensation RTD (0) is selected on a channel of the I/O device 8 AI RTD/TC 8xM12, the measurement type for Channel 0 (X1) is limited; that is, only the measurement types "Thermocouple" or "±80 mV" are possible.

A wire break at Pt1000 cannot be detected and is reported with the diagnosis "Reference channel error".

- The M12 compensation connector is provided for the temperature compensation "RTD (0)" (prerequisite: "Reference junction" parameter set to "RTD (0)"). For all other temperature compensations, no M12 compensation connector is required.

The M12 compensation connector has an integrated resistance thermometer Pt1000 (with $\alpha = 0.003851$) for compensating the reference junction temperature of the thermocouples. The α value conforms to the standards EN 60751, GOST 6651, JIS C 1604 and ASTM E-1137.

The M12 compensation connector is delivered unassembled. You can connect a thermocouple by using terminals 2 and 4 of the M12 compensation connector. The M12 compensation connector is bolted to the round socket X1 on the connection module CM IO 4 x M12 (torque: 1.5 Nm). The procedure is identical to the M12 connector (see section Mounting (Page 20)).

Note

The M12 compensation connector is only designed for the electronic module 8 AI RTD/TC 8xM12. Operation without a cable is not permitted in order to comply with degree of protection IP67.

- **Dynamic Ref. Temp.:** The reference junction temperature is measured via a module on a different station.

With this type of compensation the reference junction temperature (compensation voltage) is measured by means of an external module on another station.

The reference junction temperature is transferred from the CPU to the I/O device 8 AI RTD/TC 8xM12 by means of the data record DS2 using the SFB 53.

An separate reference junction temperature can be assigned by means of the the user program to each channel for which you select this type of compensation.

- **Fix Ref. Temp.:** The reference temperature is specified permanently.

With this type of compensation, the reference junction temperature is stored as a parameter.

The reference junction temperature is specified in the parameter "Reference temperature for TC".

The possible value range is listed in the table Reference temperature for TC (Page 192).

The parameterized reference junction temperature is valid for all the channels of the I/O device for which you have selected this type of compensation.

10.1.5 Analog value representation for measuring ranges with SIMATIC S7

Representation of analog values

With the same nominal range, the digitized analog value is the same for input and output values. Analog values are represented in two's complement.

The following table shows the representation of analog values of the analog input.

Table 10- 6 Representation of analog values (SIMATIC S7 format)

Resolution	Analog value															
Bit number	15	14	13	12	11	10	9	8	7	6	5	4	3	2	1	0
Significance of the bits	Sign	2^{14}	2^{13}	2^{12}	2^{11}	2^{10}	2^9	2^8	2^7	2^6	2^5	2^4	2^3	2^2	2^1	2^0

Sign

The sign (S) of the analog value is always in bit number 15:

- "0" → +
- "1" → -

10.1.6 Measuring ranges of the analog input device in S7 format

Voltage measuring ranges: Measuring range 1 to 5 V

Measuring range	Units		Range
	Decimal	Hexadecimal	
1 to 5 V			
> 5.704 V	32767	7FFF _H	Overflow
5.704 V	32511	7EFF _H	Ovrange
	27649	6C01 _H	
5 V	27648	6C00 _H	Nominal range
4 V	20736	5100 _H	
1 V + 144.7 μV	1	0001 _H	
1 V	0	0000 _H	
	-1	FFFF _H	Underrange
0.296 V	-4864	ED00 _H	Wire break
< 0.296 V	32767	7FFF _H	
	- 32768	8000 _H	Underflow

Voltage measuring ranges: Measuring range 0 to 10 V

Measuring range 0 to 10 V	Units		Range
	Decimal	Hexadecimal	
> 11.759 V	32767	7FFF _H	Overflow
11.759 V	32511	7EFF _H	Ovrrange
	27649	6C01 _H	
10 V	27648	6C00 _H	Nominal range
7.5 V	20736	5100 _H	
0 V + 361.7 μ V	1	0001 _H	
0 V	0	0000 _H	
	-1	FFFF _H	
-1.759 V	-4864	ED00 _H	Underrange
< -1.759 V	- 32768	8000 _H	Underflow

Measuring ranges for voltage: \pm 10 mV

Measuring range \pm 10 V	Units		Range
	Decimal	Hexadecimal	
> 11.759 V	32767	7FFF _H	Overflow
11.759 V	32511	7EFF _H	Ovrrange
	27649	6C01 _H	
10 V	27648	6C00 _H	Nominal range
7.5 V	20736	5100 _H	
361.7 μ V	1	0001 _H	
0 V	0	0000 _H	
	-1	FFFF _H	
- 7.5 V	-20736	AF00 _H	
-10 V	-27648	9400 _H	
	-27649	93FF _H	
-11.759 V	-32512	8100 _H	Underrange
< -11.759 V	-32768	8000 _H	Underflow

Current measuring range: 0 to 20 mA

Measuring range 0 to 20 mA	Units		Range
	Decimal	Hexadecimal	
> 23.52 mA	32767	7FFF _H	Overflow
23.52 mA	32511	7EFF _H	Ovrrange
	27649	6C01 _H	
20 mA	27648	6C00 _H	Nominal range
15 mA	20736	5100 _H	
723.4 nA	1	0001 _H	
0 mA	0	0000 _H	
	1	FFFF _H	
-3.52 mA	-4864	ED00 _H	Underrange
< -3.52 mA	32768	8000 _H	Underflow

Current measuring range: 4 to 20 mA

Measuring range 4 to 20 mA	Units		Range
	Decimal	Hexadecimal	
> 22.81 mA	32767	7FFF _H	Overflow
22.81 mA	32511	7EFF _H	Ovrrange
	27649	6C01 _H	
20 mA	27648	6C00 _H	Nominal range
16 mA	20736	5100 _H	
4 mA + 578.7 nA	1	0001 _H	
4 mA	0	0000 _H	
	1	FFFF _H	
1.185 mA	-4864	ED00 _H	Underrange
< 1.185 mA	32767	7FFF _H	Wire break
	-32768	8000 _H	Underflow

Measuring range for current: ± 20 mA

Measuring range ± 20 mA	Units		Range
	Decimal	Hexadecimal	
> 23.52 mA	32767	7FFF _H	Overflow
23.52 mA	32511	7EFF _H	Overrange
	27649	6C01 _H	
20 mA	27648	6C00 _H	Nominal range
15 mA	20736	5100 _H	
723.4 nA	1	0001 _H	
0 mA	0	0000 _H	
	-1	FFFF _H	
-15 mA	-20736	AF00 _H	
-20 mA	-27648	9400 _H	
	-27649	93FF _H	Underrange
-23.52 mA	-32512	8100 _H	
< -23.52 mA	-32768	8000 _H	Underflow

Measuring range for voltage: ± 80 mV

Measuring range ± 80 mV	Units		Range
	Decimal	Hexadecimal	
> 94.1 mV	32767	7FFF _H	Overflow
94.1 mV	32511	7EFF _H	Overrange
	27649	6C01 _H	
80 mV	27648	6C00 _H	Nominal range
60 mV	20736	5100 _H	
2.89 μ V	1	0001 _H	
0 mV	0	0000 _H	
	-1	FFFF _H	
-60 mV	-20736	AF00 _H	
-80 mV	-27648	9400 _H	
	-27649	93FF _H	Underrange
-94.1 mV	-32512	8100 _H	
< -94.1 mV	-32768	8000 _H	Underflow

Measuring ranges for resistance-based sensor: 150 Ω, 300 Ω, 600 Ω, 3000 Ω

Measuring range				Units		Range
				Decimal	Hexadecimal	
150 Ω	300 Ω	600 Ω	3 kΩ			
> 176.38 Ω	> 352.77 Ω	> 705.53 Ω	> 3.53 kΩ	32767	7FFF _H	Overflow
176.38 Ω	352.77 Ω	705.53 Ω	3.53 kΩ	32511	7EFF _H	Overrange
				27649	6C01 _H	
150 Ω	300 Ω	600 Ω	3 kΩ	27648	6C00 _H	Nominal range
112.5 Ω	225 Ω	450 Ω	2.25 kΩ	20736	5100 _H	
5.43 mΩ	10.85 mΩ	21.70 mΩ	108.05 mΩ	1	0001 _H	
0 Ω	0 Ω	0 Ω	0 Ω	0	0000 _H	

Negative values are physically impossible

Measuring ranges for Pt x00 standard thermal resistor

Pt x00 Standard in °C (1 digit = 0.1°C)	Units		Pt x00 Standard in °F (1 digit = 0.1°F)	Units		Pt x00 Standard in K (1 digit = 0.1 K)	Units		Range
	Decimal	Hexadecimal		Decimal	Hexadecimal		Decimal	Hexadecimal	
> 1000.0	32767	7FFF _H	> 1832.0	32767	7FFF _H	> 1273.2	32767	7FFF _H	Overflow
1000.0	10000	2710 _H	1832.0	18320	4790 _H	1273.2	12732	31BC _H	Overrange
:	:	:	:	:	:	:	:	:	
850.1	8501	2135 _H	1562.1	15621	3D05 _H	1123.3	11233	2BE1 _H	Nominal range
850.0	8500	2134 _H	1562.0	15620	3D04 _H	1123.2	11232	2BE0 _H	
:	:	:	:	:	:	:	:	:	Underrange
-200.0	-2000	F830 _H	-328.0	-3280	F330 _H	73.2	732	2DC _H	
-200.1	-2001	F82F _H	-328.1	-3281	F32F _H	73.1	731	2DB _H	Underflow
:	:	:	:	:	:	:	:	:	
-243.0	-2430	F682 _H	-405.4	-4054	F02A _H	30.2	302	12E _H	
< -243.0	-32768	8000 _H	< -405.4	-32768	8000 _H	< 30.2	32768	8000 _H	

Measuring ranges for Pt x00 climatic thermal resistor

Pt x00 Climatic in °C (1 digit = 0.01 °C)	Units		Pt x00 Climatic in °F (1 digit = 0.01 °F)	Units		Range
	Decimal	Hexadecimal		Decimal	Hexadecimal	
> 155.00	32767	7FFF _H	> 311.00	32767	7FFF _H	Overflow
155.00	15500	3C8C _H	311.00	31100	797C _H	Overrange
:	:	:	:	:	:	
130.01	13001	32C9 _H	266.01	26601	67E9 _H	Nominal range
130.00	13000	32C8 _H	266.00	26600	67E8 _H	
:	:	:	:	:	:	Underrange
-120.00	-12000	D120 _H	-184.00	-18400	B820 _H	
-120.01	-12001	D11F _H	-184.01	-18401	B81F _H	Underflow
:	:	:	:	:	:	
-145.00	-14500	C75C _H	-229.00	-22900	A68C _H	
< -145.00	-32768	8000 _H	< -229.00	-32768	8000 _H	

Measuring ranges for Ni x00 Standard thermal resistor

Ni x00 Standard in °C (1 digit = 0.1 °C)	Units		Ni x00 Standard in °F (1 digit = 0.1 °F)	Units		Ni x00 Standard in K (1 digit = 0.1 K)	Units		Range
	Decimal	Hexadec- imal		Decimal	Hexadec- imal		Decimal	Hexadec- imal	
> 295.0	32767	7FFF _H	> 563.0	32767	7FFF _H	> 568.2	32767	7FFF _H	Overflow
295.0	2950	B86 _H	563.0	5630	15FE _H	568.2	5682	1632 _H	Overrange
:	:	:	:	:	:	:	:	:	
250.1	2501	9C5 _H	482.1	4821	12D5 _H	523.3	5233	1471 _H	Nominal range
250.0	2500	9C4 _H	482.0	4820	12D4 _H	523.2	5232	1470 _H	
:	:	:	:	:	:	:	:	:	Underrange
-60.0	-600	FDA8 _H	-76.0	-760	FD08 _H	213.2	2132	854 _H	
-60.1	-601	FDA7 _H	-76.1	-761	FD07 _H	213.1	2131	853 _H	Underflow
:	:	:	:	:	:	:	:	:	
-105.0	-1050	FBE6 _H	-157.0	-1570	F9DE _H	168.2	1682	692 _H	
< -105.0	-32768	8000 _H	< -157.0	-32768	8000 _H	< 168.2	32768	8000 _H	

Measuring ranges for Ni x00 climatic thermal resistor

Ni x00 Climatic in °C (1 digit = 0.01 °C)	Units		Ni x00 Climatic in °F (1 digit = 0.01 °F)	Units		Range
	Decimal	Hexadecimal		Decimal	Hexadecimal	
> 155.00	32767	7FFF _H	> 311.00	32767	7FFF _H	Overflow
155.00	15500	3C8C _H	311.00	31100	797C _H	Overrange
:	:	:	:	:	:	
130.01	13001	32C9 _H	266.01	26601	67E9 _H	Nominal range
130.00	13000	32C8 _H	266.00	26600	67E8 _H	
:	:	:	:	:	:	Underrange
-60.00	-6000	E890 _H	-76.00	-7600	E250 _H	
-60.01	-6001	E88F _H	-76.01	-7601	E24F _H	Underflow
:	:	:	:	:	:	
-105.00	-10500	D6FC _H	-157.00	-15700	C2AC _H	
< -105.00	-32768	8000 _H	< -157.00	-32768	8000 _H	

Representation of analog values for thermocouple type E

Type E in °C	Units		Type E in °F	Units		Type E in K	Units		Range
	Decimal	Hexadec- imal		Decimal	Hexadec- imal		Decimal	Hexadec- imal	
> 1200.0	32767	7FFF _H	> 2192.0	32767	7FFF _H	> 1473.2	32767	7FFF _H	Overflow
1200.0	12000	2EE0 _H	2192.0	21920	55A0 _H	1473.2	14732	398C _H	Overrange
:	:	:	:	:	:	:	:	:	
1000.1	10001	2711 _H	1832.1	18321	4791 _H	1273.3	12733	31BD _H	Nominal range
1000.0	10000	2710 _H	1832.0	18320	4790 _H	1273.2	12732	31BC _H	
:	:	:	:	:	:	:	:	:	Underflow
-270.0	-2700	F574 _H	-454.0	-4540	EE44 _H	3.2	32	0020 _H	
< -270.0	-32768	8000 _H	< -454.0	-32768	8000 _H	< 3.2	-32768	8000 _H	

Measuring ranges for thermocouple Type N

Type N in °C	Units		Type N in °F	Units		Type N in K	Units		Range
	Decimal	Hexadec- imal		Decimal	Hexadec- imal		Decimal	Hexadec- imal	
> 1550.0	32767	7FFF _H	> 2822.0	32767	7FFF _H	> 1823.2	32767	7FFF _H	Overflow
1550.0	15500	3C8C _H	2822.0	28220	6E3C _H	1823.2	18232	4738 _H	Overrange
⋮	⋮	⋮	⋮	⋮	⋮	⋮	⋮	⋮	
1300.1	13001	32C9 _H	2372.1	23721	5CA9 _H	1573.3	15733	3D75 _H	Nominal range
1300.0	13000	32C8 _H	2372.0	23720	5CA8 _H	1573.2	15732	3D74 _H	
⋮	⋮	⋮	⋮	⋮	⋮	⋮	⋮	⋮	Underflow
-270.0	-2700	F574 _H	-454.0	-4540	EE44 _H	3.2	32	0020 _H	
< -270.0	-32768	8000 _H	< -454.0	<-32768	8000 _H	< 3.2	-32768	8000 _H	

Representation of analog values for thermocouple type J

Type J in °C	Units		Type J in °F	Units		Type J in K	Units		Range
	Decimal	Hexadec- imal		Decimal	Hexadec- imal		Decimal	Hexadec- imal	
> 1450.0	32767	7FFF _H	> 2642.0	32767	7FFF _H	> 1723.2	32767	7FFF _H	Overflow
1450.0	14500	38A4 _H	2642.0	26420	6734 _H	1723.2	17232	4350 _H	Overrange
⋮	⋮	⋮	⋮	⋮	⋮	⋮	⋮	⋮	
1200.1	12001	2EE1 _H	2192.1	21921	55A1 _H	1473.3	14733	398D _H	Nominal range
1200.0	12000	2EE0 _H	2192.0	21920	55A0 _H	1473.2	14732	398C _H	
⋮	⋮	⋮	⋮	⋮	⋮	⋮	⋮	⋮	Underflow
-210.0	-2100	F7CC _H	-346.0	-3460	F27C _H	63.2	632	0278 _H	
< -210.0	-32768	<8000 _H	< -346.0	-32768	8000 _H	< 63.2	-32768	8000 _H	

Representation of analog values for thermocouple type K

Type K in °C	Units		Type K in °F	Units		Type K in K	Units		Range
	Decimal	Hexadec- imal		Decimal	Hexadec- imal		Decimal	Hexadec- imal	
> 1622.0	32767	7FFF _H	> 2951.6	32767	7FFF _H	> 1895.2	32767	7FFF _H	Overflow
1622.0	16220	3F5C _H	2951.6	29516	734C _H	1895.2	18952	4A08 _H	Overrange
⋮	⋮	⋮	⋮	⋮	⋮	⋮	⋮	⋮	
1372.1	13721	3599 _H	2501.7	25017	61B9 _H	1645.3	16453	4045 _H	Nominal range
1372.0	13720	3598 _H	2501.6	25016	61B8 _H	1645.2	16452	4044 _H	
⋮	⋮	⋮	⋮	⋮	⋮	⋮	⋮	⋮	Underflow
-270.0	-2700	F574 _H	-454.0	-4540	EE44 _H	3.2	32	0000 _H	
< -270.0	-32768	8000 _H	< -454.0	-32768	8000 _H	< 3.2	-32768	8000 _H	

10.1.7 Dynamic reference temperature with module 8 AI RTD/TC 8xM12

Properties

You can measure the reference junction temperature of the measuring point by using the I/O device 8 AI RTD/TC 8xM12 or an external module from another station when you use the compensation type "Dynamic reference temperature". To do so, the reference temperature is transmitted with SFB 53 "WRREC" using the data record DS2 to the I/O device 8 AI RTD/TC 8xM12.

Requirements

- Standard function block SFB 53 "WRREC"
- User program

Programming

Observe the following notes on the user program:

- The permitted value range of the reference junction temperature in standard resolution corresponds to the temperature range Pt100 Climatic for platinum RTDs.
- If a reference junction temperature is received in data record DS2 that is outside the permitted value range, a diagnostic interrupt "Reference channel fault" is signaled if the "Group diagnostics" parameter has been enabled.
- All inputs signal overflow (32767) when you start the I/O device 8 AI RTD/TC 8xM12. After receiving a compensation value by means of the data record DS2, the I/O device starts reading the TC inputs and signals correct data.
- The I/O device 8 AI RTD/TC 8xM12 has a watchdog set to 5 minutes that is reset after a new compensation value was received by means of DS2. If the I/O device in standard operation does not receive DS2 data within the 5-minute interval of the watchdog, a diagnostic interrupt "Reference channel fault" is signaled if the "Group diagnostics" parameter has been enabled.
- When you use ET 200eco PN modules or other modules for measuring the reference junction temperature, the RTD module parameters/module parameters for the output structure and measuring accuracy must be represented in the DS2 by bytes 0 and 1. The figure below "Structure of data record DS2" illustrates this setting.

Structure of data record DS2

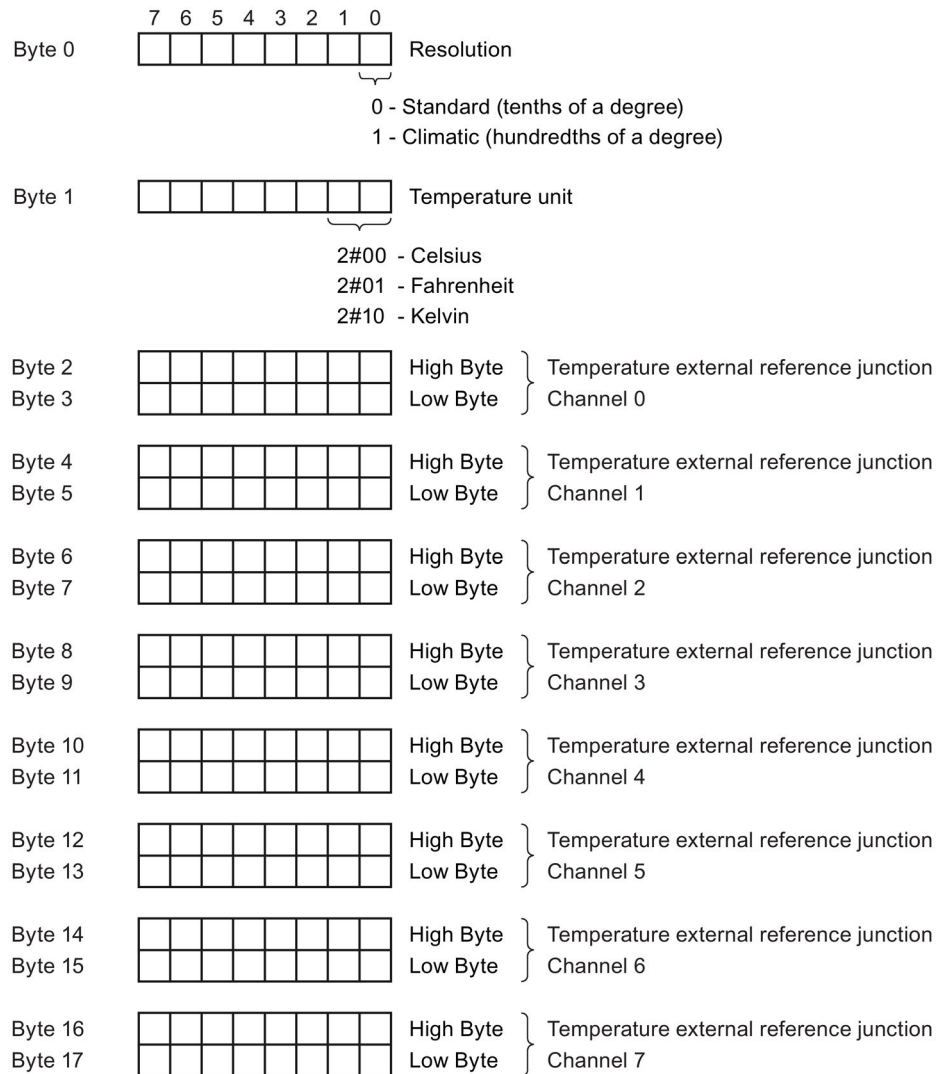

Figure 10-3 Structure of data record DS2

Table 10- 7 Reference temperature for TC

Temperature unit	Decimal	Hexadecimal
Standard temperature unit		
Celsius	-1450 to 1550	FA56 _H to 60E _H
Fahrenheit	-2290 to 3110	F70E _H to C26 _H
Kelvin	1282 to 4282	502 _H to 10BA _H
Climatic temperature unit		
Celsius	-14500 to 15500	C75C _H to 3C8C _H
Fahrenheit	-22900 to 31100	A68C _H to 797C _H
Kelvin	12815 to 32760	320F _H to 7FF8 _H

Note

You can use a separate reference junction for each channel due to the flexible structure of the data record DS2. You can also combine channels with the user program so that they use the same reference junction. All channels that operate with the same reference junction temperature must have the same temperature value in the DS2.

User program

The following user program shows an example for the compensation type "Dynamic reference temperature" of channels 0 to 7 of the I/O device 8 AI RTD/TC 8xM12 of an RTD module. The reference junction temperature of the RTD module applies to all channels of the I/O device 8 AI RTD/TC 8xM12.

Requirements:

- Input address of the I/O device 8 AI RTD/TC 8xM12: 120 (module address)
- Input address of the RTD module: 136 (channel address)
- Request bit for SFB "WRREC": M 20.0
- Busy bit for SFB "WRREC": M 20.1
- Memory for data transmission: MW 0 to MW 16

STL	Explanation
UN M 20.0	Checking the request: New Dynamic Ref. Temp.
UN M 20.1	Checking if WRREC is "Busy"
SPB END	skip if no transmission is required
U M 20.1	Checking if WRREC is "Busy"
SPB WRT	
// Create memory for data transmission	
L B#16#1	Transmit temperature in hundredths of a degree (Pt100 Climatic)
T MB 0	
L B#16#0	Transmit temperature in Celsius
T MB 1	
L PIW 136	Read in reference junction temperature of an RTD module in the plant
T MW 2	for channel 0 of the 4 AI RTD/TC
T MW 4	for channel 1 of the 4 AI RTD/TC
T MW 6	for channel 2 of the 4 AI RTD/TC
T MW 8	for channel 3 of the 4 AI RTD/TC
T MW 10	for channel 4 of the 4 AI RTD/TC
T MW 12	for channel 5 of the 4 AI RTD/TC
T MW 14	for channel 6 of the 4 AI RTD/TC
T MW 16	for channel 7 of the 4 AI RTD/TC
// Transmit the reference junction temperature to the RTD/TC	
WRT :CALL "WRREC", DB53	
REQ :=M20.0	Request bit for data transmission
ID :=DW#16#78	Input address 120 of the 8 AI RTD/TC
INDEX :=2	Data record number must be set to 2
LEN :=18	Length 18 bytes
DONE :=	
BUSY :=M20.1	Busy bit from SFB "WRREC"
ERROR :=	
STATUS :=MD24	
RECORD :=P#M0.0 BYTE 18	Pointer to memory for data transmission, length 18 bytes

10.1 I/O device analog input

STL	Explanation
U M 20.1	Checking if WRREC is "Busy"
SPB END	
CLR	
= M 20.0	Reset request for Dynamic Ref. Temp.
END :NOP 0	

This is only an example. The logic and memory assignment have to be adapted to the structure of the used PLC program.

Addition information on SFB 53 "WRREC" is available in the System Software for S7-300/400 System and Standard Functions manual.

10.2 I/O device analog output

10.2.1 I/O device 4 AO U/I 4xM12

Article number

6ES7145-6HD00-0AB0

Properties

- 4 outputs for voltage or current output
- Output ranges:
 - ± 10 V, resolution 15 bits + sign
 - 1 to 5 V, resolution 15 bits
 - 0 to 10 V, resolution 15 bits
 - ± 20 mA, resolution 15 bits + sign
 - 4 to 20 mA, resolution 15 bits
 - 0 to 20 mA, resolution 15 bits
- Supply voltage DC 24 V
- Dimensions 60 x 175 mm
- Diagnostics
 - "Missing 1L+" supply voltage
 - "Sensor supply short-circuit"
 - "Wire break"
 - "Short-circuit"
 - "Overload"
- Parameterizable response to CPU/Master STOP
- Prioritized startup
- Media redundancy

Note

Incorrect intermediate values at the output are possible when supply voltage 1L+ is switched on and off.

Note

The outputs are in voltage mode and supply a signal 0 V until the parameter assignment becomes effective after switching on.

Pin assignment

You will find the pin assignment for the 4 AO U/I 4×M12 I/O device in the table below.

Table 10- 8 Pin assignment for voltage and current for the 4 AO U/I 4×M12 I/O device

Pin	Assignment for U/I				View of socket (front view)
	Socket X1	Socket X2	Socket X3	Socket X4	
1	24 V actuator supply 1U _A (derived from 1L+ non-switched)				
2	Output signal				
	Q ₀₊	Q ₁₊	Q ₂₊	Q ₃₊	
3	Actuator supply ground 1M				
4	Output signal				
	Q ₀₋	Q ₁₋	Q ₂₋	Q ₃₋	
5	Functional earth FE				

Block diagram

The block diagram below shows the 4 AO U/I 4×M12.

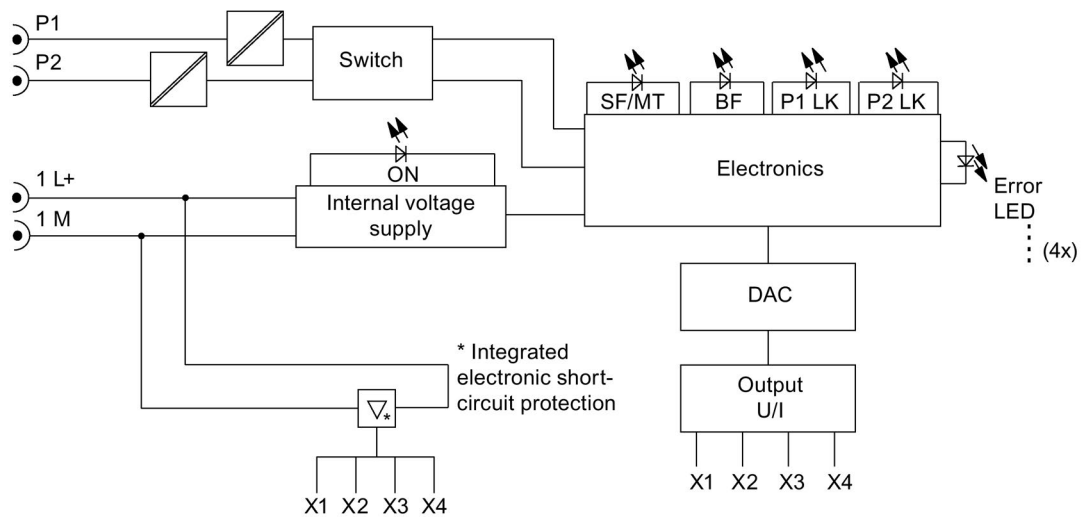

Figure 10-4 Block diagram 4 AO U/I 4xM12

Technical data

Technical data	
Dimensions and weight	
Dimensions W x H x D (mm)	60 x 175 x 49
Weight	Approx. 930 g
Module-specific data	
Transmission rate	100 Mbps full duplex
Transmission mode	100BASE-TX
Autonegotiation	Yes
Bus protocol	PROFINET IO <ul style="list-style-type: none"> • IRT with the option "high flexibility" • IRT with the option "high performance"
Supported Ethernet services	PROFINET IO (Device) <ul style="list-style-type: none"> • ping • arp • LLDP • Network diagnostics (SNMP) • DCP • Prioritized startup • Media redundancy
PROFINET interface	
• Connection socket	2 x M12 d-coded
• Switch function	Yes, internal
• Auto-crossover	Yes, if autonegotiation is enabled
Manufacturer ID (Vendor ID)	002A _H
Device ID (DeviceID)	0306 _H
Voltages and currents	
Supply voltage 1L+	DC 24 V
Reverse polarity protection	Yes; against destruction
• Infeed current 1L+	Max. 4 A
Supply voltage 2L+	DC 24 V
• Infeed current 2L+	Max. 4 A
Current consumption	
• From supply voltage (1L+)	Typ. 280 mA
• From supply voltage (2L+)	0 A
Power loss of the device	Typ. 5.5 W

Technical data	
Analog outputs	
Number of outputs	4
Cable length, shielded	Max. 30 m
Voltage	
• Short-circuit protection	Yes, electronic, to ground
• Short-circuit current	Max. 30 mA
Current	
• No-load voltage	Max. 20 V
Actuator supplies	
Number of actuator supplies	4
Total current	Max. 1 A
Short-circuit protection	Yes, electronic
• Response threshold	Min. 1.4 A
Actuator selection data	
Output ranges (Rated value)	
Voltage	±10 V 1 V to 5 V 0 V to 10 V
Current	±20 mA 4 to 20 mA 0 to 20 mA
Load resistance (in the Rated range of the output)	
• For voltage outputs	Min. 1 kΩ
• For voltage outputs, capacitive load	Max. 1 μF
• For current outputs	Max. 0.6 kΩ
• For current outputs, inductive load	Max. 1 mH
Permissible input voltage at the output (destruction limit)	28.8 V continuous, 35 V for 500 ms
Connection of actuators	
• For voltage output, 2-wire connection	Yes
• For current output, 2-wire connection	Yes
Formation of analog values	
Conversion principle	Resistor network
• Conversion time per channel, in ms	1 ms
• Voltage resolution (including overrange)	±10 V/15 bits + sign 1 to 5 V/15 bits 0 to 10 V/15 bits
• Current resolution (including overrange)	±20 mA/15 bits + sign 4 to 20 mA/15 bits 0 to 20 mA/15 bits

Technical data				
Settling time	U	I		
• For resistive load	1.3 ms	2 ms		
• For capacitive load	1.8 ms	-		
• For inductive load	-	2 ms		
Ability to switch to substitute values	Yes			
Interference suppression, error limits				
Crosstalk between outputs	Min. 70 dB			
Operational limit (across the temperature range, relative to output range)	Ambient temperature			
		positive	negative (0 °C to -25 °C)	negative (-25 °C to -40 °C)
	U	0.1%	0.15%	0.3%
	I	0.15%	0.25%	0.4%
Basic error limit (operational limit at 25°C, relative to output range)	U	0.08%		
	I	0.1%		
Temperature error (relative to output range)	Ambient temperature			
		positive	negative	
	U	0.001%/K	0.003%/K	
	I	0.0025%/K	0.005%/K	
Linearity error (relative to output range)	± 0.02%			
Repeat accuracy (in steady-state condition at 25°C, relative to output range)	±0.008%			
Output ripple (relative to output range, bandwidth 0 to 50 kHz)	U	±0.6 mVrms		
	I	±0.4 nArms		
Status, interrupts, diagnostics				
Interrupts	Yes			
Diagnostics functions				
• Group error/maintenance	Red/yellow "SF/MT" LED			
• Bus monitoring PROFINET IO	Red "BF" LED			
• Monitoring of supply voltage 1L+	Green "ON" LED			
• Existing connection to network	Green "P1 LK" and "P2 LK" LED; LED for PROFINET IO infeed and loop-through			
• Fault at analog output	Red LED			
• Diagnostic information can be read	Yes			
Monitoring for				
• Supply voltage 1L+	Yes			
• Sensor supply short-circuit	Yes			
• Short-circuit	Yes; channel (voltage)			
• Wire break	Yes; channel (current)			
• Thermal overload at output	Yes; channel			

Technical data	
Insulation	
Insulation test voltage	
• Ethernet interface	1500 V _{rms} (IEEE802.3)
• All other circuit elements	707 V DC (type test)
Electrical isolation	
• Between 1L+ and 2L+	Yes
• Between 1L+, channels and all other circuit elements	No
• Between channels	No
• Between Ethernet and all other circuit elements	Yes

See also

Response times for analog input device and output device (Page 258)

10.2.2 Parameter overview analog output

Parameters for analog output 4 AO U/I 4xM12 (6ES7145-6HD00-0AB0)

Parameters	Range of values	Default setting	Range of effectiveness
Group diagnostics	<ul style="list-style-type: none"> Disable Enable 	Disable	Device
Diagnostics, missing 1L+	<ul style="list-style-type: none"> Disable Enable 	Disable	Device
Diagnostics, sensor supply short-circuit	<ul style="list-style-type: none"> Disable Enable 	Disable	Device
Response to CPU/Master STOP	<ul style="list-style-type: none"> Output has no current or voltage Retain last value Switch to substitute values 	Output has no current or voltage	Device
Type of output	<ul style="list-style-type: none"> Disabled Voltage Current 	Voltage	Channel
Output range	<ul style="list-style-type: none"> 1 to 5 V 0 to 10 V ±10 V 0 to 20 mA 4 to 20 mA ±20 mA 	±10 V	Channel
Diagnostics, wire break at outputs	<ul style="list-style-type: none"> Disable Enable 	Disable	Channel
Diagnostics, short-circuit at outputs	<ul style="list-style-type: none"> Disable Enable 	Disable	Channel
Diagnostics, overload	<ul style="list-style-type: none"> Disable Enable 	Disable	Channel
Substitute value	Each value in the nominal range, overrange, and underrange	0	Channel

Output range	Permitted substitute value
1 to 5 V	0.000 V to 5.704 V
0 to 10 V	0.000 V to 11.759 V
±10 V	-11.759 V to 11.759 V
0 to 20 mA	0.000 mA to 23.518 mA
4 to 20 mA	0.000 mA to 22.814 mA
±20 mA	-23.519 mA to 23.518 mA

10.2.3 Parameter description analog output

Group diagnostics

You can generally enable and disable the diagnostics function of the device with this parameter.

The "Fault" and "Parameter assignment error" diagnostics functions are always independent of the group diagnostics.

Diagnostics, missing 1L+

If you enable this parameter, the check for missing supply voltage is enabled.

Diagnostics, sensor supply short circuit

When this parameter is enabled, the system generates a diagnostics event if it detects a short-circuit of the sensor supply to ground. This diagnostics function is activated when the group diagnostics function is enabled.

Response to CPU/Master STOP

Select how the module's outputs will respond to a CPU STOP:

- Shut down
The I/O device goes to the safe state. The process image output is deleted (=0).
- Keep last value
The I/O device retains the last value to be output before STOP.
- Substitute value
The I/O device outputs the value for the channel set beforehand.

Note

Make sure that the plant is always in a safe state if "Keep last value" is selected.

Type of output

With this parameter, you set the output type, for example, voltage. For any unused channels, select the **disabled** setting. For a disabled channel, the conversion time and integration time of the channel = 0 s, and the cycle time is optimized.

Output range

With this parameter, you set the output range of the selected output type.

Diagnostics, wire break (in current mode)

When this parameter is enabled, the **Wire break** diagnostics event is generated when a wire break is detected. This diagnostics event cannot be detected in the zero range.

Diagnostics, short circuit (in voltage mode)

If you enable this parameter, a diagnostics event is generated in the event of a short circuit in the output line. This diagnostics event cannot be detected in the zero range.

Diagnostics, overload

If you enable this parameter, the diagnostics event is generated in the event of an overload.

Substitute values

With this parameter, you enter a substitute value that the module is to output in CPU-STOP mode. The substitute value must be in the nominal range, overrange, or underrange.

10.2.4 Output ranges of analog output device

Output ranges for voltage and current: ± 10 V; ± 20 mA

Output range ± 10 V	Output range ± 20 mA	Units		Range	
		Decimal	Hexadecimal		
0.00 V	0.00 mA	32767	7FFF _H	Overflow	
		32512	7F00 _H		
11.76 V	23.52 mA	32511	7EFF _H	Overrange	
		27649	6C01 _H		
10 V	20 mA	27648	6C00 _H	Nominal range	
7.5 V	15 mA	20736	5100 _H		
361.7 μ V	723.4 nA	1	0001 _H		
0 V	0 mA	0	0000 _H		
-361.7 μ V	-723.4 nA	-1	FFFF _H		
-7.5 V	-15 mA	-20736	AF00 _H		
-10 V	-20 mA	-27648	9400 _H		
		-27649	93FF _H		Underrange
-11.76 V	-23.52 mA	-32512	8100 _H		
		-32513	80FF _H		Underflow
0.00 V	0.00 mA	-32768	8000 _H		

Output ranges for voltage and current: 1 to 5 V; 4 to 20 mA

Output range 1 to 5 V	Output range 4 to 20 mA	Units		Range	
		Decimal	Hexadecimal		
0.00 V	0.00 mA	32767	7FFF _H	Overflow	
		32512	7F00 _H		
5.70 V	22.81 mA	32511	7EFF _H	Overrange	
		27649	6C01 _H		
5 V	20 mA	27648	6C00 _H	Nominal range	
4 V	16 mA	20736	5100 _H		
1 V + 144.7 μ V	4 mA + 578.7 nA	1	0001 _H		
1 V	4 mA	0	0000 _H		
		-1	FFFF _H		Underrange
0 V	0 mA	-6912	E500 _H		
		-6913	E4FF _H	Underflow	
0.00 V	0.00 mA	-32768	8000 _H		

Output ranges for voltage and current: 0 to 10 V; 0 to 20 mA

Output range 0 to 10 V	Output range 0 to 20 mA	Units		Range
		Decimal	Hexadecimal	
0.00 V	0.00 mA	32767	7FFF _H	Overflow
		32512	7F00 _H	
11.76 V	23.52 mA	32511	7EFF _H	Overrange
		27649	6C01 _H	
10 V	20 mA	27648	6C00 _H	Nominal range
7.5 V	15 mA	20736	5100 _H	
361.7 µV	723.4 nA	1	0001 _H	
0 V	0 mA	0	0000 _H	
		-1	FFFF _H	Underflow
0.00 V	0.00 mA	-32768	8000 _H	

10.3 Influence of the range of values

Influence of analog signal on input value

The response of the I/O devices with analog inputs depends on the position of the input values within the range of values. The table below shows this dependency.

The measured value lies	Result	SF LED	Diagnostics data range of device	Interrupt
Within the nominal range	Measured value	-	-	-
Within the overrange/underrange	Measured value	-	-	-
Within the overflow	7FFF _H	On	Entry ¹	Diagnostic interrupt ¹
Within the underflow	8000 _H	On	Entry ¹	Diagnostic interrupt ¹
Before parameter assignment	7FFF _H	-	-	-
Within an incorrect parameter assignment ²	Measured value	On	Entry	Diagnostic interrupt
Within an incorrect initial parameter assignment	7FFF _H	On	Entry	Diagnostic interrupt

¹ If the the **group diagnostics** and **measuring range** parameters are enabled for the input device.

² If a channel was previously parameterized correctly, it continues running with the last parameters.

Influence of output value on analog output

The response of I/O devices with analog outputs depends on the position of the input values within the range of values. The table below shows this dependency.

The output value lies	Result	SF LED	Diagnostics data range of device	Interrupt
Within the nominal range	Value from the IO Controller	-	-	-
Within the overrange/underrange	Value from the IO Controller	-	-	-
Within the overflow	0 signal	-	-	-
Within the underflow	0 signal	-	-	-
Before parameter assignment	0 signal	-	-	-
Within an incorrect parameter assignment ¹	Value from the IO Controller	On	Entry	Diagnostic interrupt
Within an incorrect initial parameter assignment	0 signal	On	Entry	Diagnostic interrupt

¹ If a channel was previously parameterized correctly, it continues running with the last parameters.

IO-Link Master

11.1 IO-Link Master (6ES7148-6JA00-0AB0)

Article number

6ES7148-6JA00-0AB0

Properties

The IO-Link Master 4 IO-L + 8 DI + 4 DO DC 24V/1,3A 8×M12 has the following technical specifications:

- IO-Link Master according to IO-Link specification V1.0
- Dimensions 60 x 175 mm
- Double assignment of the sockets
- 4 IO-Link ports (Port Class A)
- IO-Link ports can be used optionally as:
 - 4 IO-Link devices as 3-conductor connection
 - 4 standard actuators/encoders (SIO mode)
- 8 digital inputs and 4 digital outputs
- Digital inputs
 - Rated input voltage DC 24 V
 - Suitable for switches and proximity switches
 - Diagnostics
 - "Missing 2L+" for the I/O device
 - "Short-circuit to M at sensor supply", per channel group
 - "Wire break", per channel
 - Channels 4 to 7 are diagnostics-capable, Channels 0 to 3 do not have diagnostics.
- Digital outputs
 - Rated load voltage DC 24 V
 - Output current: 1.3 A per output
 - Suitable for solenoid valves, DC contactors, and indicator lights
 - Diagnostics
 - "Missing 2L+" for the I/O device
 - "Wire break at outputs" per channel
 - "Short-circuit to M at outputs" per channel
 - Parameterizable response to CPU/Master STOP
- Data transfer rates COM1 (4.8 kBaud), COM2 (38.4 kBaud)

The module supports the following functions:

- Prioritized startup
- Media redundancy (as of firmware V7.0)

General pin assignment

Table 11- 1 Pin assignment of sockets X1 to X4 for IO-Link Master and digital inputs

Pin	Assignment				View of socket (front view)
	Socket X1	Socket X2	Socket X3	Socket X4	
1	24 V sensor supply 1Us(derived from 1L+ non-switched)				
2	Input signal				
	DI ₀	DI ₁	DI ₂	DI ₃	
3	Sensor supply ground 1M				
4	IO-Link port 1	IO-Link port 2	IO-Link port 3	IO-Link port 4	
5	Not used				

Table 11- 2 Pin assignment of the sockets X5 to X6 for digital inputs

Pin	Assignment		View of socket (front view)
	Socket X5	Socket X6	
1	24 V sensor supply 1Us(derived from 1L+ non-switched)		
2	Input signal		
	DI ₅	DI ₇	
3	Sensor supply ground 1M		
4	Input signal		
	DI ₄	DI ₆	
5	Functional earth FE		

Table 11- 3 Pin assignment of sockets X7 and X8 for digital outputs

Pin	Assignment		View of socket (front view)
	Socket X7 (2L+ switched)	Socket X8 (2L+ switched)	
1	Not used		
2	Output signal		
	DQ ₁	DQ ₃	
3	Supply ground 2M		
4	Output signal		
	DQ ₀	DQ ₂	
5	Functional earth FE		

Block diagram

The figure below shows the block diagram of the IO-Link Master 4 IO-L + 8 DI + 4 DO DC 24V/1,3A 8×M12.

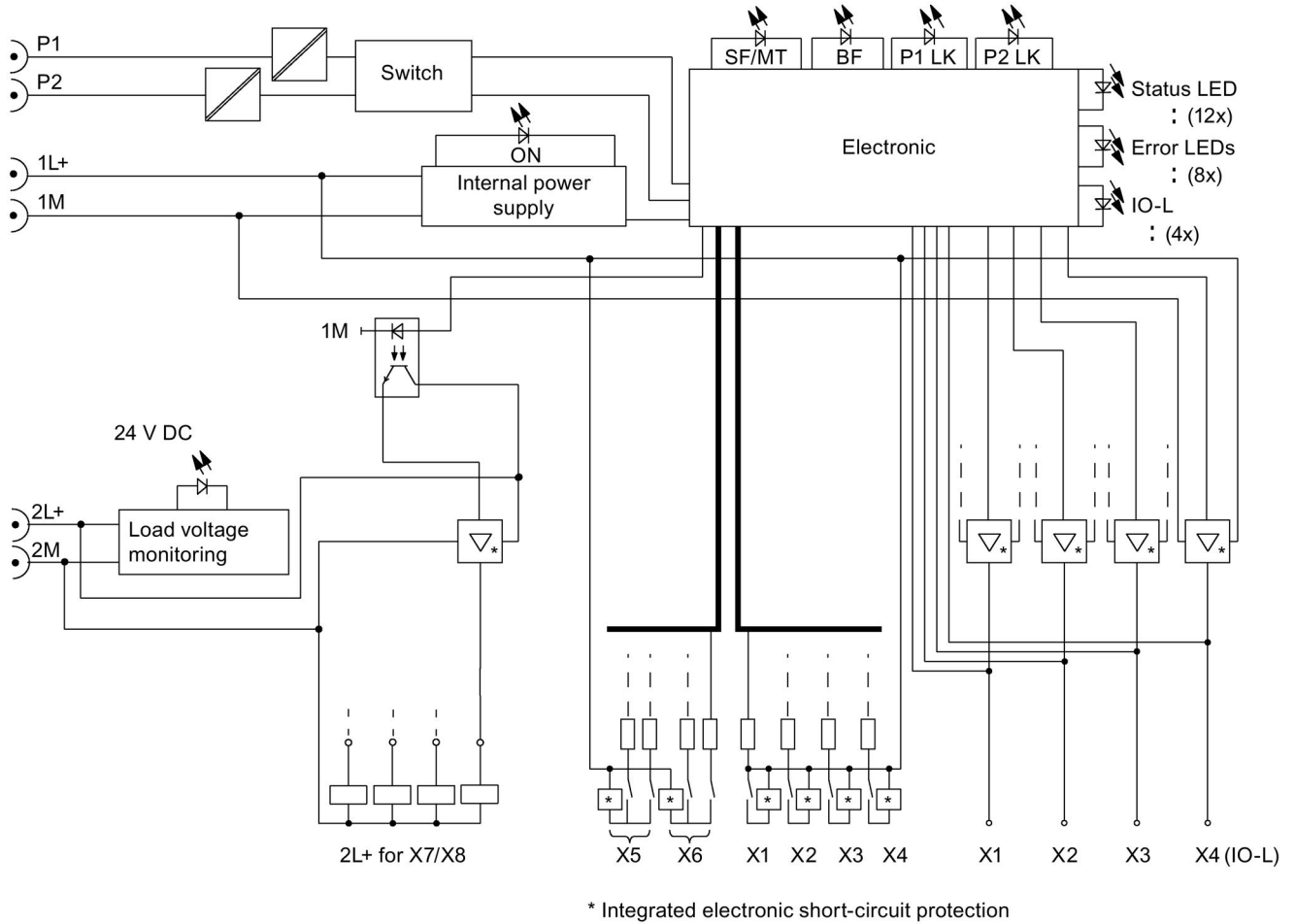

Figure 11-1 Block diagram of the IO-Link Master 4 IO-L + 8 DI + 4 DO DC 24V/1,3A 8×M12

Technical data of the IO-Link Master

Technical data	
Dimensions and weight	
Dimensions W x H x D (mm)	60 x 175 x 49
Weight	Approx. 910 g
Module-specific data	
Transmission rate	100 Mbps full duplex
Transmission mode	100BASE-TX
Autonegotiation	Yes
Bus protocol	PROFINET IO <ul style="list-style-type: none"> • IRT with the option "high flexibility"
Supported Ethernet services	PROFINET IO (Device) <ul style="list-style-type: none"> • ping • arp • LLDP • Network diagnostics (SNMP) • DCP • Prioritized startup • Media redundancy (as of firmware V7.0)
PROFINET interface	
• Connection socket	2 x M12 d-coded
• Switch function	Yes, internal
• Auto-crossover	Yes; if autonegotiation is enabled
Manufacturer ID (Vendor ID)	002A _H
Device ID (DeviceID)	0306 _H
Voltages and currents	
Supply voltage 1L+	DC 24 V
• Reverse polarity protection	Yes; against destruction
• Infeed current 1L+	Max. 4 A
Supply voltage 2L+	DC 24 V
• Reverse polarity protection	Yes, against destruction, loads are activated
• Infeed current 2L+	Max. 4 A
Total current of the outputs	
• All mounting positions to 60°C	3.9 A
Current consumption	
From supply voltage (1L+)	Typ. 200 mA
From supply voltage (2L+)	Typ. 5 mA
Power loss of the device	Typ. 8 W

Technical data	
Insulation	
Insulation test voltage	
• Ethernet interface	1500 V _{rms} (IEEE802.3)
• All other circuit elements	707 V DC (type test)
Electrical isolation	
• Between 1L+ and 2L+	Yes
• Between 1L+, channels and all other circuit elements	No
• Between channels	No
• Between Ethernet and all other circuit elements	Yes
Status, interrupts, diagnostics	
Interrupts	Yes
Diagnostics function	Yes
• Group error/maintenance	Red LED / yellow LED "SF/MT"
• Bus monitoring PROFINET IO	Red "BF" LED
• Monitoring of supply voltage 1L+	Green "ON" LED
• Monitoring of supply voltage 2L+	Green "24 V DC" LED
• Existing connection to network	Green "P1 LK" and "P2 LK" LED; LED for PROFINET IO infeed and loop-through
• IO-Link port	Green LED "IO-L"
• Digital input/digital output	Green LED
• Fault at digital input/digital output	Red LED
• Diagnostic information can be read	Yes
Monitoring for	
• Missing 2L+	Yes
• Short-circuit of the sensor supply to M	Yes, for Channels 4 to 7, per channel group
• Short-circuit at output (Channel 0 to 3)	Yes, per channel
• Wire break at input	Input current < 0.3 mA per channel
• Wire break at output (Channel 0 to 3)	Yes, in the off state, per channel
Sensor supply	
Number of sensor supplies	6 (X1-X4 (IO-LINK/DI) and X5-X6 (DI))
Load current	200 mA per output to X1-X4 (IO-LINK/DI) 100 mA per output to X5-X6 (DI)
Short-circuit protection	Yes, electronic
IO-Link port	
Number of ports	4

Technical data	
Number of ports that can be controlled simultaneously	4, in all mounting positions
IO-Link protocol 1.0	Yes
IO-Link protocol 1.1	No
Transmission rate	4.8 kBaud (COM1), 38.4 kBaud (COM2)
Size of the process data, input per port	32 bytes
Size of the process data, input per module	32 bytes
Size of the process data, output per port	32 bytes
Size of the process data, output per module	32 bytes
Digital inputs	
Number of inputs	8
Number of inputs that can be controlled simultaneously	8, in all mounting positions
Digital outputs	
Number of outputs	4
IO-Link Device selection data (Port 1 to 4)	
Cable length, unshielded	Max. 20 m
Connection of IO-Link devices	
Port type A	Yes; with 3-wire cable
Operating modes	
IO-Link	Yes
DI	Yes
DQ	Yes
Sensor selection data (input signals 0 to 7 only)	
Cable length, shielded	Max. 30 m
Cable length, unshielded	Max. 30 m
Input voltage	
• Nominal value	DC 24 V
• For signal "1"	11 to 30 V
• For signal "0"	-3 to 5 V
Input current	
• At signal "1"	Typ. 7 mA
Input delay	
• At "0" to "1"	Typ. 3 ms
• At "1" to "0"	Typ. 3 ms
Input characteristic	According to IEC 61131, Type 3
Connection of 2-wire proximity switches	Supported
• Permitted quiescent current	Max. 1.5 mA

Technical data	
Actuator selection data (output signals 0 to 3 only)	
Cable length, shielded	Max. 30 m
Cable length, unshielded	Max. 30 m
Output voltage	
• Nominal value	DC 24 V
• For signal "1"	Min. 1L+/2L+ (-0.8 V)
Output current	
• At signal "1"	Max. 1.3 A
• For "0" signal (residual current)	Max. 1.5 mA
Load resistance range	22 Ω to 3.3 kΩ
Lamp load	Max. 5 W
Parallel wiring of two outputs	
• To increase performance	No
• For redundant control of a load	Supported
Controlling of a digital input	Yes
Switching frequency	
• With resistive load	Max. 100 Hz
• With inductive load	Max. 0.5 Hz
• With lamp load	Max. 1 Hz
Limiting of the inductive shutdown voltage to lamp load	Typ. 1L+/2L+ (-47 V)
Short-circuit protection of the output	Yes, electronic
• Response threshold	Typ. 1.8 A (per channel)

11.1.1 Parameters for IO-Link Master

Parameters for the IO-Link Master 4 IO-L + 8 DI + 4 DO DC 24V/1,3A 8×M12

Parameters	Range of values	Default setting	Range of effectiveness	
Slot 1 "4 IO-L"				
Group diagnostics	<ul style="list-style-type: none"> • Disable • Enable 	Disable	Slot 1	
Diagnostics enable for Ports 1	<ul style="list-style-type: none"> • Disable • Enable 	Disable	Channel	
Diagnostics enable for Port 2	<ul style="list-style-type: none"> • Disable • Enable 	Disable	Channel	
Diagnostics enable for Port 3	<ul style="list-style-type: none"> • Disable • Enable 	Disable	Channel	
Diagnostics enable for Port 4	<ul style="list-style-type: none"> • Disable • Enable 	Disable	Channel	
Slot 2 "8 DI + 4 DO DC 24V/1,3A 8×M12"				
Group diagnostics	<ul style="list-style-type: none"> • Disable • Enable 	Disable	Slot 2	
Diagnostics: Missing 2L+	<ul style="list-style-type: none"> • Disable • Enable 	Disable	Channel group	
Response to CPU/Master STOP	<ul style="list-style-type: none"> • Shut down • Retain last value 	Shut down	Slot 2	
Inputs				
Channel 4	Diagnostics: Short-circuit of the sensor supply to M	<ul style="list-style-type: none"> • Disable • Enable 	Disable	Channel group*
	Diagnostics: Wire break	<ul style="list-style-type: none"> • Disable • Enable 	Disable	Channel
Channel 5	Diagnostics: Short-circuit of the sensor supply to M	<ul style="list-style-type: none"> • Disable • Enable 	Disable	Channel group*
	Diagnostics: Wire break	<ul style="list-style-type: none"> • Disable • Enable 	Disable	Channel
Channel 6	Diagnostics: Short-circuit of the sensor supply to M	<ul style="list-style-type: none"> • Disable • Enable 	Disable	Channel group*
	Diagnostics: Wire break	<ul style="list-style-type: none"> • Disable • Enable 	Disable	Channel

Parameters		Range of values	Default setting	Range of effectiveness
Channel 7	Diagnostics: Short-circuit of the sensor supply to M	<ul style="list-style-type: none"> • Disable • Enable 	Disable	Channel group*
	Diagnostics: Wire break	<ul style="list-style-type: none"> • Disable • Enable 	Disable	Channel
Outputs				
Channel 0	Diagnostics: Short-circuit of outputs to M	<ul style="list-style-type: none"> • Disable • Enable 	Disable	Channel
	Diagnostics: Wire break	<ul style="list-style-type: none"> • Disable • Enable 	Disable	Channel
Channel 1	Diagnostics: Short-circuit of outputs to M	<ul style="list-style-type: none"> • Disable • Enable 	Disable	Channel
	Diagnostics: Wire break	<ul style="list-style-type: none"> • Disable • Enable 	Disable	Channel
Channel 2	Diagnostics: Short-circuit of outputs to M	<ul style="list-style-type: none"> • Disable • Enable 	Disable	Channel
	Diagnostics: Wire break	<ul style="list-style-type: none"> • Disable • Enable 	Disable	Channel
Channel 3	Diagnostics: Short-circuit of outputs to M	<ul style="list-style-type: none"> • Disable • Enable 	Disable	Channel
	Diagnostics: Wire break	<ul style="list-style-type: none"> • Disable • Enable 	Disable	Channel

* Channel group is defined by the digital inputs of the M12 socket. Example:

- Channel 4 and Channel 5 form the channel group of connection socket X5.
- Channel 6 and Channel 7 form the channel group of connection socket X7.

Generally short-circuit monitoring of the M12 digital input socket is only carried once via Pin 1 (1L+) and Pin 3 (1M). The short-circuit parameterization can be used to select which channel of the M12 socket reports the short-circuit or whether both channels report the short-circuit.

11.1.2 Functions

Introduction

You can select one of the following operating modes for each of the four ports of the IO-Link Master:

- IO-Link
- DI
- DQ
- Disabled

You make the selection in the Port Configurator tool during parameterization. If no parameters have been assigned, the ports will be disabled.

Note

Value status

The value status (PortQualifier) is relevant in IO-Link mode only.

Value status

Each port has a value status display (PortQualifier) per device. The value status shows if the process data is valid or invalid.

By default, the value status (PortQualifier) is disabled.

IO-Link

In IO-Link mode, the port is in IO-Link communication. There are two data transmission rates in this operating mode. COM1 with 4.8 kBaud; COM2 with 38.4 kBaud. The data transmission rate depends on the IO-Link Device used. The IO-Link Master and the IO-Link Device used automatically negotiate the maximum data transmission rate at startup.

DI

In DI mode, a port of the IO-Link Master behaves like a standard DI.

DQ

In DQ mode, a port of the IO-Link Master behaves like a standard DQ.

Disabled

The respective port of the IO-Link Master is disabled in Disabled mode. The ports are disabled if the IO-Link Master has not yet been parameterized with *S7-PCT* (default setting).

Consistency width of 8 byte

The IO-Link Master has a consistency width of 8 byte. In addition to the upper limit of 32 byte input and 32 byte output for the entire IO-Link Master, there are other upper limits of 8 byte input and 8 byte output per IO-Link Device (per port).

11.2 IO-Link Master (6ES7148-6JD00-0AB0)

Article number

6ES7148-6JD00-0AB0

Properties

The IO-Link Master 4 IO-L 4×M12 has the following technical specifications:

- IO-Link Master according to IO-Link specification V1.1
- Dimensions 30 x 200 mm
- 4 IO-Link ports (Port Class B)
- IO-Link ports can be used optionally as:
 - 4 IO-Link devices (Port Class A oder Class B) with variable address area up to 32 byte inputs/32 byte outputs per port
 - 4 standard actuators/encoders (SIO mode)
- Data transfer rates COM1 (4.8 kBaud), COM2 (38.4 kBaud), COM3 (230.4 kBaud)
- Configurable diagnostics can be set per port (in IO-Link mode)
- Parameterization of IO-Link parameters per S7-PCT V3.4 and higher **or**
- Autostart (without S7-PCT)
- Hardware interrupts (in IO-Link mode)

The module supports the following functions:

- Master backup
- Firmware update
- Media redundancy
- Identification and maintenance data I&M0 to I&M3

General pin assignment

Table 11- 4 Pin assignment of sockets X1 to X4 for IO-Link master

Pin	Assignment				View of socket (front view)
	Socket X1	Socket X2	Socket X3	Socket X4	
1	24 V sensor supply 1U _S (derived from 1L+ non-switched)				
2	24 V actuator supply 2U _A (derived from 2L+ switched)				
3	Sensor supply ground 1M				
4	IO-Link port 1	IO-Link port 2	IO-Link port 3	IO-Link port 4	
5	Actuator supply ground 2M				

Additional information on pin assignment including wiring examples for the 3- and 5-conductor connection (Port Class A or Class B) is available in the chapter Pin assignment for IO-Link Masters (Page 49).

Block diagram

The figure below shows the block diagram of the IO-Link master 4 IO-L 4×M12.

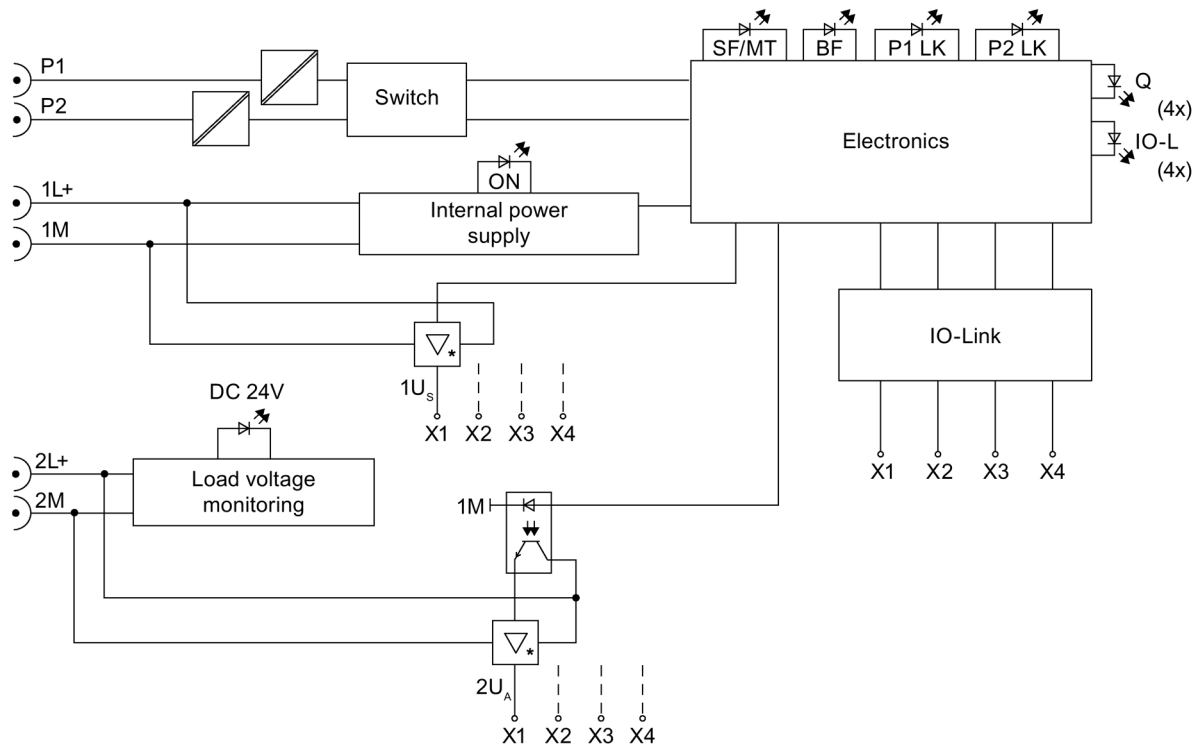

* Integrated electronic short-circuit protection

Figure 11-2 Block diagram of the IO-Link Master 4 IO-L 4×M12

Technical data of the IO-Link Master

Technical data	
Dimensions and weight	
Dimensions W x H x D (mm)	30 x 200 x 49
Weight	Approx. 550 g
Module-specific data	
Transmission rate	100 Mbps full duplex
Transmission mode	100BASE-TX
Autonegotiation	Yes
Bus protocol	PROFINET IO <ul style="list-style-type: none"> • IRT
Supported Ethernet services	PROFINET IO (Device) <ul style="list-style-type: none"> • ping • arp • LLDP • Network diagnostics (SNMP) • DCP • Port diagnostics • Media redundancy • I&M0-3 • Resetting to factory settings
PROFINET interface	
• Connection socket	2 × M12 d-coded
• Switch function	Yes, internal
• Autocrossing	Yes; if autonegotiation is enabled
Manufacturer ID (Vendor ID)	002A _H
Device ID (DeviceID)	0306 _H
Voltages and currents	
Supply voltage 1L+	DC 24 V
• Reverse polarity protection	Yes
• Infeed current 1L+	Max. 4 A
Load voltage 2L+	DC 24 V
• Reverse polarity protection	Yes, against destruction, loads are activated
• Infeed current 2L+	Max. 4 A
Current consumption	
From supply voltage (1L+)	Typ. 100 mA
From supply voltage (2L+)	Typ. 15 mA
Power loss of the device	Typ. 4.8 W

Technical data	
Insulation	
Insulation test voltage	
• Ethernet interface	1500 V _{rms} (IEEE802.3)
• All other circuit elements	707 V DC (type test)
Electrical isolation	
• Electrical isolation / between the load voltages	Yes
• between load voltage and all other circuit elements	No
• Between Ethernet and electronic components	Yes
Status, interrupts, diagnostics	
Interrupts	Yes
• Hardware interrupt (device notification)	Yes
Diagnostics function	Yes
• Group error/maintenance	Yes; red/yellow LED "SF/MT"
• Bus monitoring PROFINET IO	Red "BF" LED
• Monitoring of supply voltage 1L+	Green "ON" LED
• Monitoring of supply voltage 2L+	Green "24 V DC" LED
• Existing connection to network	Green "P1 LK" and "P2 LK" LED for PROFINET IO infeed and loop-through
• IO-Link port – Port in IO-Link mode – Port in SIO mode	green/red LED "IO-L" Green LED "Q"
• Diagnostic information can be read	Yes
Monitoring for	
• Missing 2L+	Yes
• Sensor supply short-circuit	Yes; device supply to ground
Sensor supply	
Number of outputs	4
Load current	500 mA per output
Short-circuit protection	Yes, electronic
IO-Link port	
Number of ports	4
Number of ports that can be controlled simultaneously	4, in all mounting positions
IO-Link protocol 1.0	Yes
IO-Link protocol 1.1	Yes
Transmission rate	4.8 kBaud (COM1), 38.4 kBaud (COM2), 230.4 kBaud (COM3)

Technical data	
Size of the process data, input per port	32 bytes + 1 byte PQI
Size of the process data, input per module	128 bytes + 4 bytes PQI
Size of the process data, output per port	32 bytes
Size of the process data, output per module	128 bytes
Memory size for device parameters	2 Kbytes; for each port
Master backup	optional; with IO_LINK_MASTER function block
Configuration without S7-PCT	supported; autostart function
Data for selection of an IO-Link device	
Cable length, unshielded	Max. 20 m
Connection of IO-Link devices	
Port type A	Yes; with 3-wire cable
Port type B	Yes; additional device supply: Max. 2 A per Port, max. 4 A per module
Operating modes	
IO-Link	Yes
DI	Yes
DQ	Yes; max. 100 mA

11.2.1 Configuration

Introduction

The IO-Link Master 4 IO-L 4×M12 has four ports. Each port is represented by a submodule.

Configuration of the IO-Link port of the IO-Link Master 4 IO-L 4×M12

You specify the various operating modes of each IO-Link port by configuring a relevant submodule:

- as digital input by configuring a digital input submodule,
- as digital output by configuring a digital output submodule,
- as IO-Link device by configuring an IO-Link submodule.
- Port deactivated:
 - In STEP 7 V5.5 and higher and with GSD: By deleting the submodule,
 - in STEP 7 (TIA Portal): By deactivating the port enable.

The IO-Link ports are preconfigured as 2I + PQI.

When configuring IO-Link submodules, you can select address spaces for I/O data in the following byte scales:

- 1 I/1 O + PQI
- 2 I + PQI
- 2 I/2 O + PQI
- 4 I/4 O + PQI
- 8 I/8 O + PQI
- 16 I/16 O + PQI
- 32 I/32 O + PQI

Note

Port Qualifier Information (PQI)

The Port Qualifier Information (PQI) with the size of 1 byte is always transferred together with the input data of the IO-Link device. The PQI cannot be deactivated. Additional information on the structure of the PQI byte is available in the appendix I/O address space (Page 250).

Various parameters are available depending on the operating mode.

More information on the parameters is available in the chapter Parameter (Page 223).

11.2.2 Parameter

Port parameters for the IO-Link Master 4 IO-L 4×M12

Parameters	Range of values	Default setting
IO-Link master (for each submodule/port)		
Autostart (without S7-PCT)	<ul style="list-style-type: none"> • Disable • Enable 	Disable
Diag: Port	<ul style="list-style-type: none"> • Disable • Enable 	Disable
Diag: Missing 2L+	<ul style="list-style-type: none"> • Disable • Enable 	Disable
Hardware interrupt (device notification)	<ul style="list-style-type: none"> • Disable • Enable 	Disable

Explanation of the parameters

Autostart (without S7-PCT)

These parameters enable the commissioning of an IO-Link device without using the S7-Port Configuration Tools (S7-PCT).

This is started automatically (plug-and-play functionality) when an IO-Link device is connected. The IO-Link device is operational and immediately available to the user.

Note

Changes to the port configuration

If you have assigned the parameters for the IO-Link device via Autostart (without S7-PCT), or have configured the port as digital input, digital output or disabled, you can no longer change the port configuration via S7-PCT.

Diag: Port

Enabling of the diagnostics for the selected port.

A distinction is made between error and maintenance interrupts during the diagnostics. The possible diagnostics depend on the IO-Link device used. More information on the diagnostic interrupts is available in the description of the IO-Link device that is used.

Diag: Missing 2L+

Enabling of diagnostics in the case of missing or insufficient load voltage 2L+.

Hardware interrupt (device notification)

Enabling of hardware interrupts for the selected port.
The possible hardware interrupts depend on the IO-Link device that is used. More information on the hardware interrupts is available in the description of the IO-Link device that is used.

Note

Configuration as digital input or output

Please note that you cannot activate any port parameters or diagnostic alarms in SIO mode.

11.2.3 Functions

Introduction

A brief overview of the operating modes of the ports and additional functions of the IO-Link Master 4 IO-L 4×M12 is presented below.

IO-Link

In IO-Link mode, the port is in IO-Link communication. There are three data transmission rates in this operating mode: COM1 with 4.8 kBaud, COM2 with 38.4 kBaud and COM3 with 230.4 kBaud. The data transmission rate depends on the IO-Link Device used. The IO-Link Master and the IO-Link Device used automatically negotiate the maximum data transmission rate at startup.

DI

In DI mode, a port of the IO-Link Master behaves like a standard DI.

DQ

In DQ mode, a port of the IO-Link Master behaves like a standard DQ.

Disabled

If you have deleted the submodule or deactivated the port enable, the port is deactivated.

Port Qualifier Information (PQI)

Each port has a PortQualifierInformation (PQI). This PQI provides information on port- and IO-Link device status. The PQI is transferred cyclically with the process data. The PQI cannot be deactivated.

The structure of the PQI byte is available in the appendix I/O address space (Page 250).

Firmware update

The IO-Link master firmware is update capable.
Additional information on firmware updates for the ET 200eco PN is available in the chapter Online firmware update by means of STEP 7 Manager (Page 80).

Master backup

All relevant IO-Link-device parameters and IO-Link-master parameters are read with the function block "IO_LINK_MASTER". These can be stored retentively at a central location, for example, in a data block in the IO controller.

The status of the IO-Link devices and IO-Link ports can be restored with the "IO_LINK_MASTER" function block.

The parameters of the IO-Link ports and the IO-Link master are assigned with the values stored in the master backup.

A typical use case is restoring the parameters after the exchange of the IO-Link master.

Note

Availability

Note that the Master Backup function is only available for IO-Link devices that are specified for the IO-Link standard as of V1.1.

More information on the use of the function blocks for the master backup and master restore is available in the chapter Acyclic data exchange with the IO-Link library (Page 81).

More information on Master Backup and Master Restore is available in the Master Backup section of the Integration in the Automation System chapter of the IO-Link System (<https://support.industry.siemens.com/cs/ww/en/view/65949252>) function manual.

Identification and maintenance data

The identification and maintenance data (I&M data) is information that is saved as read-only (I data) or read/write (M data) on the module.

Identification data (I&M0): Manufacturer information on the module to which you only have read access and some of which may be printed on the module housing, for example, article number and serial number.

Maintenance data (I&M1, 2, 3): Plant dependent information, such as installation location.

The identification data I&M support you in the following tasks:

- Checking the plant configuration
- Locating hardware modifications in a plant
- Correcting errors in a plant

Modules are uniquely identifiable online with the I&M identification data.

In addition, you can read the identification data contained in the IO-Link device as I&M0 via the associated submodule.

11.2.4 Interrupts

Introduction

According to IEC 61131-9, IO-Link devices are able to generate events of the types error, warning and notification. These events are mapped directly to the interrupts of the assigned submodule.

Evaluating interrupts with IO controller

The IO-Link Master 4 IO-L 4×M12 supports the following interrupts:

- Diagnostic interrupts (at IO-Link Master / at submodule port)
- Hardware interrupts (at submodule port)
- Pull/plug interrupts (at submodule port)
- Maintenance events (at submodule port)

In the case of an interrupt, the CPU of the IO controller automatically calls the interrupt OBs. The OB number and the start information provide you with information about the cause and class of the error.

You can obtain detailed information on the error event in the error OB with the "RALRM" instruction (read supplementary interrupt information).

System diagnostics

In STEP 7 (TIA Portal), the innovated system diagnostics is available for the devices of the S7-1500 automation system (IO controller CPU S7-1500) and ET 200eco PN (IO device). Alarms are made available on the display of the S7-1500 CPU, the CPU Web server and the HMI device.

More information on system diagnostics is available in the Diagnostics function manual on the Internet (<https://support.industry.siemens.com/cs/ww/en/view/59192926>).

11.2.4.1 Triggering of a diagnostic interrupt

Introduction

All IO-Link events of the type error, which the IO-Link Device generates, as well as problems and errors at the IO-Link port (for example Diag: Missing 2L+), are mapped to the diagnostic interrupts for the assigned submodule.

Triggering of a diagnostic interrupt

If you have assigned the parameters for the IO-Link master accordingly, this triggers a diagnostic interrupt for an incoming or outgoing event of the IO-Link device.

The CPU interrupts the processing of the user program and processes the diagnostic interrupt OB (OB 82). The event that led to the triggering of the interrupt is entered in the start information of the diagnostic interrupt OB.

11.2.4.2 Triggering a hardware interrupt

Introduction

All IO-Link events of the type notification which the IO-Link device generates are mapped to the hardware interrupts of the assigned submodule.

Triggering a hardware interrupt

In the event of a hardware interrupt the CPU interrupts the processing of the user program and processes the hardware interrupt OB (for example, OB 40). The event that led to the triggering of the interrupt is entered in the start information of the hardware interrupt OB.

11.2.4.3 Triggering of a pull/plug interrupt

Introduction

If you remove an IO-Link device or interrupt communication, a pull interrupt is generated by the assigned submodule.

A plug interrupt is triggered as soon as the IO-Link device is plugged in again or IO-Link communication re-established.

Triggering of a pull/plug interrupt

In the case of a pull/plug interrupt, the CPU interrupts the processing of the user program and process the pull/plug OB (OB 83). The event that led to the triggering of the interrupt is entered in the start information of the pull/plug OB.

11.2.5 Maintenance events

Introduction

All IO-Link events of the type warning which the IO-Link device generates are mapped to the maintenance interrupts of the assigned submodule. The objective is early detection and elimination of potential disturbances.

With the IO-Link master, maintenance events indicate to the user when a check or an exchange of network components is required.

The CPU interrupts processing of the user program and processes the diagnostics block OB82. The event which led to the triggering of the maintenance event is entered in the start information of the OB82.

System alarms in STEP 7 (TIA Portal)

The maintenance information is generated in STEP 7 (TIA Portal) with the following system alarms:

- Maintenance demanded - symbolized for each port by a wrench (on a yellow background)  in the device view or in the hardware configuration.

You can find additional information in the STEP 7 online help.

Terminal block and voltage distributor

12.1 Terminal block

Article number

6ES7194-6CA00-0AA0

Properties

The terminal block has the following properties:

- The terminal block can be inserted and screw-mounted on any I/O device
- It can also be used separately.
- It distributes 10 A per supply voltage 1L+ and 2L+ to the I/O devices. You can tap a maximum load of 4 A from each supply voltage of the I/O device. The voltages are protected with two 7.5 A fuses.

Pin assignment

The tables below show the pin assignments.

Table 12- 1 Pin assignment of the insulation displacement terminal block.

Pin	Assignment	View of the insulation displacement terminal block:
1	24 V (1L+ non-switched)	
2	Ground 1M (non-switched)	
3	24 V (2L+ switched)	
4	Ground 2M (switched)	

12.1 Terminal block

Table 12- 2 Pin assignment of the M12 connector

Pin	Assignment	View of the cable connector
1	24 V (1L+ non-switched)	
2	Ground 2M (switched)	
3	Ground 1M (non-switched)	
4	24 V (2L+ switched)	

Block diagram

The block diagram below shows the terminal block.

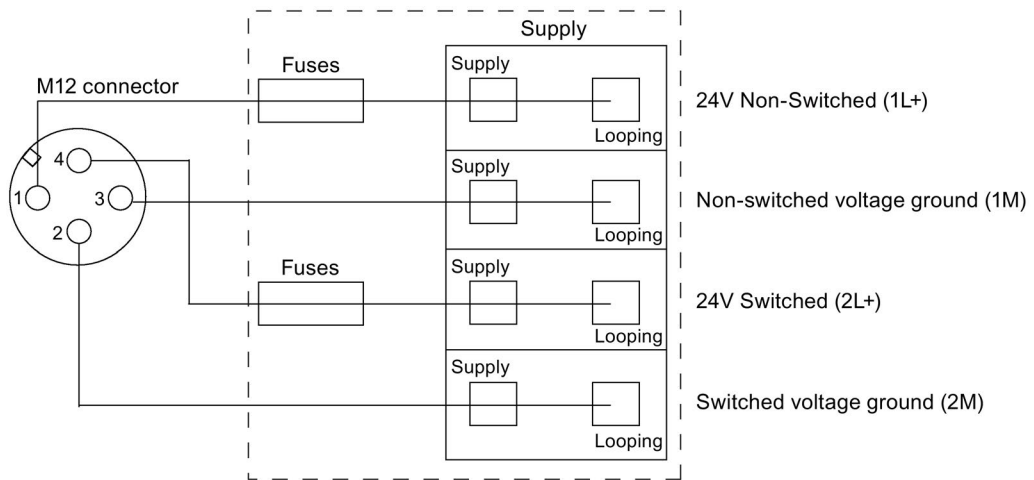

Figure 12-1 Block diagram of the terminal block

Technical data

Dimensions and Weight	
Dimensions W x H x D (mm)	30 x 50 x 98
Weight	Approx. 90 g
Current	
Infeed current 1L+ and 2L+	Max. 10 A per 1L+ and 2L+
Output current via the M12 connector	Max. 4 A per 1L+ and 2L+
Power loss	
Power loss of the terminal block	1 W, typical

See also

Installing the terminal block (Page 25)

12.2 Voltage distributor

Article number

6ES7148-6CB00-0AA0

Properties

The voltage distributor PD DC 24V 1×7/8" 4×M12 has the following properties:

- It distributes the centrally fed supply voltage (7/8") to 4 connectors (M12).
- Integrated electronic short-circuit protection
- Direct connection of up to 4 I/O devices
- Distribution of 1L+ and 2L+

Pin assignment

The tables below show the pin assignments.

Table 12- 3 Pin assignment of the 7/8" connector as current input

Pin	Assignment	View of the 7/8" cable connector, 24 V connection
1	Ground 2M (switched)	
2	Ground 1M (non-switched)	
3	Functional earth FE	
4	24 V (1L+ non-switched)	
5	24 V (2L+ switched)	

Table 12- 4 Pin assignment of the M12 connector as current output

Pin	Assignment	View of the M12 connection plug (front view)
1	24 V (1L+ non-switched)	
2	Ground 2M (switched)	
3	Ground 1M (non-switched)	
4	24 V (2L+ switched)	
5	Not used	

Block diagram

The figure below shows the block diagram of the voltage distributor PD DC 24V 1×7/8" 4×M12.

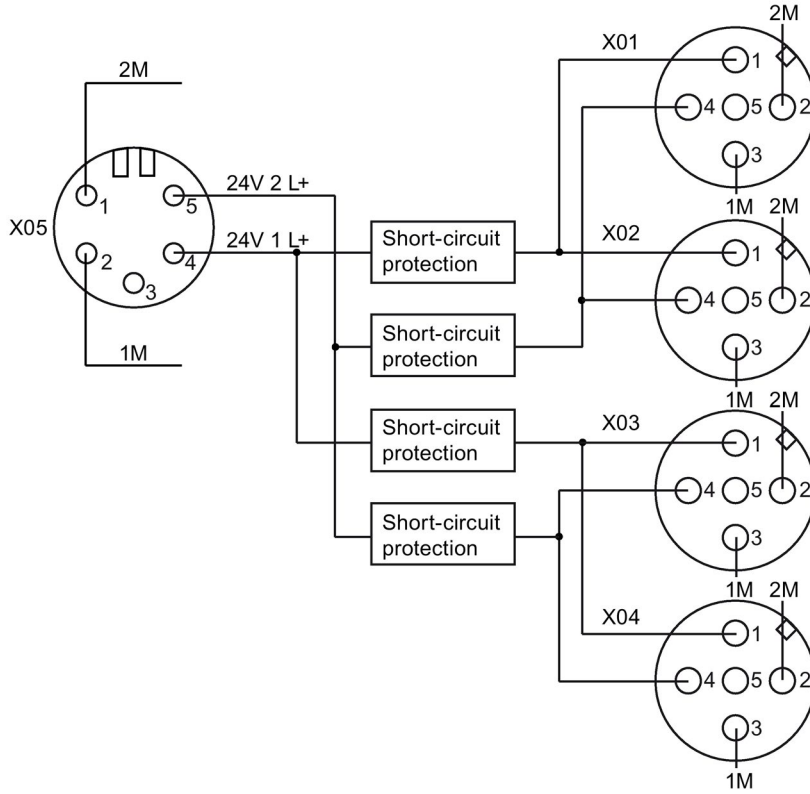

Figure 12-2 Block diagram of the voltage distributor PD DC 24V 1×7/8" 4×M12

Technical data

Dimensions and Weight	
Dimensions W x H x D (mm)	45 x 175 x 49
Weight	Approx. 590 g
Voltages and currents	
Supply voltage 1L+	DC 24 V
• Reverse polarity protection	Yes; against destruction (continuously without load)
• Infeed current 1L+	8 A
Supply voltage 2L+	DC 24 V
• Reverse polarity protection	Yes; against destruction (continuously without load)
• Infeed current 2L+	8 A
Total current of the outputs	
• All mounting positions to 45 °C	for X1 and X2 in total max. 4 A for 1L+ for X1 and X2 in total max. 4 A for 2L+ for X3 and X4 in total max. 4 A for 1L+ for X3 and X4 in total max. 4 A for 2L+
• All mounting positions to 55 °C	for X1 and X2 in total max. 3 A for 1L+ for X1 and X2 in total max. 3 A for 2L+ for X3 and X4 in total max. 3 A for 1L+ for X3 and X4 in total max. 3 A for 2L+
• Number of outputs	4, with 1L+ and 2L+ each
Input voltage/loop-through	Green LED "1L+" and "2L+"
• Nominal value	DC 24 V
Short-circuit protection of the output	Yes, electronic
• Response threshold	Typ. 4.5 A
Power loss of the voltage distributor	Typ. 3.5 W
Insulation	
Insulation test voltage	
• Ethernet interface	1500 V _{rms} (IEEE802.3)
• All other circuit elements	707 V DC (type test)
Electrical isolation	
• Between 1L+ and 2L+	Yes
Status, interrupts, diagnostics	
Diagnostics functions	
• Input/output voltage	Green LED "1L" and "2L"

Signal names

A.1 Signal names

Signal names of the I/O devices

Table A- 1 Signal names of the digital inputs and digital outputs (DI/DQ)

Signal name	Meaning
xL+	Input external auxiliary voltage DC (x: load group)
xM	Ground external auxiliary voltage DC (x: load group)
DI _{xUs}	Digital input (x: load group)
DQ _{xUs}	Digital output (x: load group)
DIQ _{xUs}	Digital input/digital output (x: load group)
U _{Sn}	Sensor supply voltage, channel n
1U _S	24 V sensor supply 1U _S (derived from 1L+ non-switched)

Table A- 2 Signal names of the analog inputs (AI)

Signal name	Meaning
xL+	Input external auxiliary voltage (x: load group)
xM	Ground external auxiliary voltage (x: load group)
M _{n+}	Measuring input channel n (voltage, current, RTD, TC, etc.)
M _{n-}	Measuring input channel n (voltage, current, RTD, TC, etc.)
I _{Cn+}	Power output power supply RTD channel n
I _{Cn-}	Power output power supply RTD channel n
U _{Vn+}	Infeed voltage for 2DMU
U _{Sn}	Sensor supply voltage, channel n
1U _S	24 V sensor supply 1U _S (derived from 1L+ non-switched)

Table A- 3 Signal names of the analog outputs (AQ)

Signal name	Meaning
xL+	Input external auxiliary voltage (x: load group)
xM	Ground external auxiliary voltage (x: load group)
Q _{n+}	Output channel n (current or voltage)
Q _{n-}	Output channel n (current or voltage)
U _{An}	Actuator supply voltage, channel n

Article numbers

I/O devices

Table B- 1 I/O devices: Article numbers

Designation	Article number
Digital input devices	
8 DI DC 24V 4×M12	6ES7141-6BF00-0AB0
8 DI DC 24V 8×M12	6ES7141-6BG00-0AB0
16 DI DC 24V 8×M12	6ES7141-6BH00-0AB0
Digital output devices	
8 DO DC 24V/1,3A 4×M12	6ES7142-6BF00-0AB0
8 DO DC 24V/0,5A 4×M12	6ES7142-6BF50-0AB0
8 DO DC 24V/1,3A 8×M12	6ES7142-6BG00-0AB0
8 DO DC 24V/2,0A 8×M12	6ES7142-6BR00-0AB0
16 DO DC 24V/1,3A 8×M12	6ES7142-6BH00-0AB0
Digital input/digital output device	
8 DIO DC 24V/1,3A 8×M12	6ES7147-6BG00-0AB0
Analog input device	
8 AI 4 U/I + 4 RTD/TC 8×M12	6ES7144-6KD00-0AB0
8 AI RTD/TC 8×M12	6ES7144-6KD50-0AB0
Analog output device	
4 AO U/I 4×M12	6ES7145-6HD00-0AB0
IO-Link master	
4 IO-L + 8 DI + 4 DO DC 24V/1,3A 8×M12	6ES7148-6JA00-0AB0
4 IO-L 4×M12	6ES7148-6JD00-0AB0

Accessories for I/O devices

Table B- 2 Accessories for I/O devices: Article numbers

Designation	Article number	
Accessories		
Voltage distributor PD DC 24V 1x7/8" 4xM12	6ES7148-6CB00-0AA0	
Terminal block	6ES7194-6CA00-0AA0	
Mounting rail, 500 mm	6ES7194-6GA00-0AA0	
Profile screws, 50 items	6ES7194-6MA00-0AA0	
AS interface accessory M12 cover for IP67 devices	3RK1901-1KA00	
Labels 10 x 7 mm, pale turquoise, 816 items per pack	3RT1900-1SB10	
Accessories for the interface "PROFINET M12 connection X1 P1/P2 LAN"		
SIMATIC NET IE M12 Plug pro M12 connector with rugged metal housing and quick connection technology, with 180° cable exit (D-coded), for SCALANCE X208pro and ET 200pro PN	1 pack = 1 units	6GK1901-0DB10-6AA0
	1 pack = 8 units	6GK1901-0DB10-6AA8
Connector for PROFINET 4-core, shielded	3RK1902-2DA00	
SIMATIC NET IE FC M12 plug pro, M12 connector with rugged metal housing and FC connection technology, axial cable exit (D-coded), for SCALANCE X208pro and ET 200pro PN	1 pack = 1 units	6GK1901-0DB20-6AA0
	1 pack = 8 units	6GK1901-0DB20-6AA8
PROFINET M12 connecting cables		
SIMATIC NET; IE FC TP Standard Cable, GP 2x2 (PROFINET TYPE A), TP installation cable for connection to FC outlet RJ45, for universal usage, 4-wire, shielded CAT 5, sold in meters, delivery unit maximum length of 2000 m, minimum order length 20 m	6XV1840-2AH10	
SIMATIC NET; IE FC TP trailing Cable, GP 2x2 (PROFINET TYPE C), TP installation cable for connection to FC outlet RJ45, for drag chain use, 4-wire, shielded CAT 5, sold in meters (5 million bend cycles), delivery unit maximum length of 2000 m, minimum order length 20 m	6XV1840-3AH10	
SIMATIC NET; IE FC TP trailing Cable, GP 2x2 (PROFINET TYPE C), TP installation cable for connection to FC outlet RJ45, for drag chain use, 4-wire, CAT 5, sold in meters (1 million bend cycles), delivery unit maximum length of 1000 m, minimum order length 20 m	6XV1870-2D	
SIMATIC NET; IE FC TP Marine Cable, TP installation cable for connection to FC outlet RJ45, ratified by ship builders, 4-wire, shielded CAT 5, sold in meters, delivery unit maximum length of 1000 m, minimum order length 20 m	6XV1840-4AH10	
SIMATIC NET; IE FC TP Torsion Cable, 2x2 (PROFINET TYPE C), TP installation cable, 4-wire, for use in highly flexible applications (torsion), sold in meters, delivery unit maximum of 1000 m, minimum order amount 20 m	6XV1870-2F	

Designation		Article number
SIMATIC NET, IE Connecting Cable M12-180/M12-180, preassembled IE FC Trailing Cable GP, with 2 x M12 connectors (D-coded)	0.3 m	6XV1870-8AE30
	0.5 m	6XV1870-8AE50
	1.0 m	6XV1870-8AH10
	1.5 m	6XV1870-8AH15
	2.0 m	6XV1870-8AH20
	3.0 m	6XV1870-8AH30
	5.0 m	6XV1870-8AH50
	10.0 m	6XV1870-8AN10
	15.0 m	6XV1870-8AN15
Bus line for PROFINET, converted on both sides, 4-wire, shielded, converted with 2 x M12 D coded, angled	3.0 m	6RK1902-2NB30
	5.0 m	6RK1902-2NB50
	10.0 m	6RK1902-2NC10
Bus line for PROFINET, converted on one side, 4-wire, shielded, converted with 1 x M12 D coded	3.0 m	3RK1902-2HB30
	3.0 m	3RK1902-2HB50
	10.0 m	3RK1902-2HC10
Miscellaneous		
AS interface accessory M12 sealing cap for IP67 modules		3RX9802-0AA00
Accessory for the interface "M12-socket X1 to X4/X8"		
Non-converted connector		
M12 jack, 5-pin, can be pre-assembled, max. 0.75 mm ² , screw terminals, type M, NO+NC		3RK19024BA00-5AA0
Angle M12 jack, 5-pin, can be pre-assembled, max. 0.75 mm ² , screw terminals, type M, IP67, NO+NC		3RX8000-0CE55
M12 jack, 4-pin, can be assembled, max. 0.75 mm ² , screw terminals, type L, IP67, NO+NC		3RX8000-0CD40
M12 plug-in cables, shielded, for connecting digital and analog sensors and actuators		(on request)
Preassembled cable		
Connecting cable M12-M12, 3-pin, PUR cable, 3 × 0.34 mm ² , type E, L, IP67, NO, straight female connector M12 to straight male connector M12	0.6 m	3RX8000-0GF32-1AA6
	1.0 m	3RX8000-0GF32-1AB0
	1.5 m	3RK19024PB15-3AA0
Connecting cable M12-M12, 4-pin, PUR cable, 4 × 0.34 mm ² , type F, L, IP67, NO+NC, straight female connector M12 to straight male connector M12	0.6 m	3RX8000-0GF42-1AA6
	1.0 m	3RX8000-0GF42-1AB0
	1.5 m	3RX8000-0GF42-1AB5
Angled cable connector M12, 4-pin, 5M PUR line, 4 x 0.34 mm ² , type L, IP 67, NO+NC	5.0 m	3RX8000-0CE42-1AF0
	10 m	3RX8000-0CE42-1AL0
Angled cable connector M12, 5-pin, PUR line, 5 x 0.34 mm ² , type G, IP67, NO+NC	1.5 m	3RX8000-0CE52-1AB5
	5.0 m	3RX8000-0CE52-1AF0
	10 m	3RX8000-0CE52-1AL0
Unassembled cables		
Compensation connector M12 with integrated PT1000 for reference junction compensation when connecting thermocouples		6ES7194-4AB00-0AA0
Y cable		
SIMATIC DP, Y cable for distributed I/O for double connection of I/O by means of a single cable, 5-pin M12, 200 mm		6ES7194-6KA00-0XA0

Designation	Article number	
Accessories for the interface "DC 24 V IN/OUT M12 (X02/X03)"		
SIMATIC NET, IE Power M12 Cable Connector pro, connection socket for connecting SCALANCE W-700/X208pro for 24 V DC supply voltage, 4-pin, A-coded, with mounting instructions, 3 items	6GK1907-0DC10-6AA3	
SIMATIC NET, IE Power M12 Plug pro, plug connector for connecting Power Supply PS791-1 pro for 24 V DC supply voltage, 4-pin, A-coded, with mounting instructions, 3 items	6GK1907-0DB10-6AA3	
Power Connecting Cable M12-180/M12-180 for power supply of the ET 200, presassembled cable with M12 connector and M12 socket, A-coded, 5-pin	0.3 m	6XV1801-5DE30
	0.5 m	6XV1801-5DE50
	1.0 m	6XV1801-5DH10
	1.5 m	6XV1801-5DH15
	2.0 m	6XV1801-5DH20
	3.0 m	6XV1801-5DH30
	5.0 m	6XV1801-5DH50
	10.0 m	6XV1801-5DN10
	15.0 m	6XV1801-5DN15

Accessories for voltage distributors

Table B- 3 Accessories for voltage distributors: Article numbers

Designation	Article number	
Accessories for the interface "DC 24V IN 7/8" (X05)"		
7/8" connector with axial cable exit for field assembly ET 200, female insert	6KG19050FB00	
24 V socket - 7/8" angled, 5-pin	3RK1902-3DA00	
SIMATIC NET, Energy Cable, 5-wire power cable, stranded wire, 5 × 1.5mm ² , suitable for cable carriers, delivery unit max. 1000 m, minimum order amount 20 m	6XV1830-8AH10	
Power Connecting Cable M12-180/M12-180 for power supply of the ET 200, presassembled cable with M12 connector and M12 socket, A-coded, 5-pin	0.3 m	6XV1801-5DE30
SIMATIC NET, 7/8" connector for power supply of the ET200, preassembled cable with 2 7/8" connectors, 5-pin	1.5 m	6XV1822-5BH15
	2.0 m	6XV1822-5BH20
	3.0 m	6XV1822-5BH30
	5.0 m	6XV1822-5BH50
	10.0 m	6XV1822-5BN10
	15.0 m	6XV1822-5BN15
Power cable 7/8" for 24 V, switched and non-switched, assembled with 2 x 7/8 both sides angled, 1.5 mm ² , pin - socket 5-pin	1.5 m	(on request)
	2.0 m	(on request)
	3.0 m	3RK1902-3NB30
	5.0 m	3RK1902-3NB50
	10.0 m	3RK1902-3NC10
	15.0 m	(on request)
Power cable 7/8" for 24 V, switched and non-switched, assembled with 1 x 7/8" one side angled, 1.5 mm ² , socket, 5-pin	3.0 m	3RK1902-3GB30
	5.0 m	3RK1902-3GB50
	10.0 m	3RK1902-3GC10

Spare parts

Table B- 4 Spare parts: Article numbers

Designation	Article number
Spare fuses for terminal block (miniature copper flat fuse, type FK1, 7.5 A, fast-blow)	6ES7194-6HB00-0AA0

PROFINET IO

Technical book	Contents	Article number
Automating with PROFINET - Industrial Communication based on Industrial Ethernet	This book provides an introduction to the new PROFINET technology	Commercial book number: ISBN 3-89578-244-0

SIMATIC Manual Collection

Designation	Contents	Article number
SIMATIC Manual Collection	Contains all SIMATIC manuals in electronic format	6ES7998-8XC01-8YE0

Technical Product Data - CD ROM

Designation	Contents	Article number
Technical Product Data for CAx Applications	Contains the following technical product data for CAD/CAE sys- tems: <ul style="list-style-type: none"> • Technical data according to ECAD component standard V1.2 • Graphical data (drawings) • Circuit-diagram macros 	6ES7991-0CC00-0YX0

Dimensional drawings

C.1 Dimensional drawings

Dimensional drawing of the I/O devices of 30 mm width

The figure shows the dimensional drawing of the I/O devices:

- 8 DI DC 24V 4×M12
- 8 DO DC 24V/1,3A 4×M12
- 8 DO DC 24V/0,5A 4×M12
- 4 IO-L 4×M12

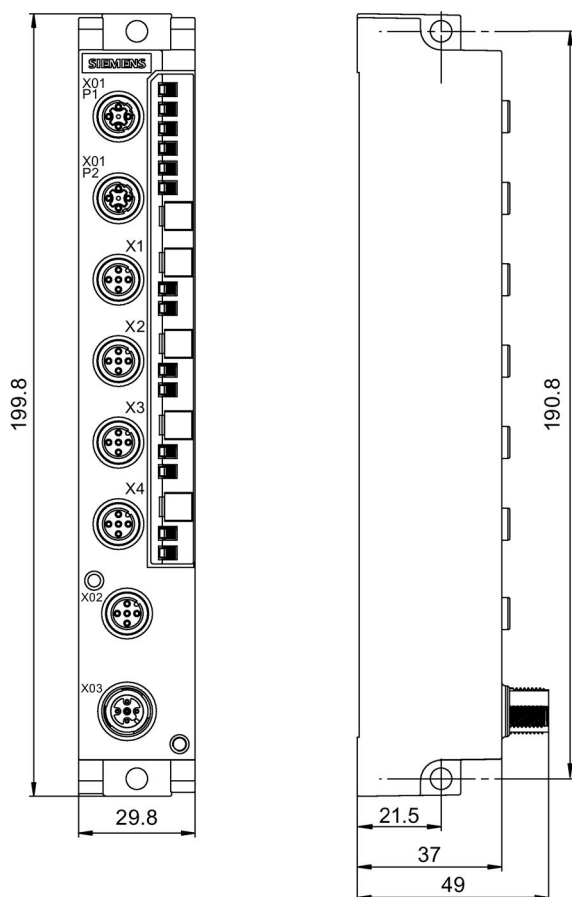

Dimensional drawing of the I/O devices of 60 mm width

The figure shows the dimensional drawing of the I/O devices:

- 8 DI DC 24V 8×M12 (current figure)
- 16 DI DC 24V 8×M12
- 8 DO DC 24V/1,3A 8×M12
- 8 DO DC 24V/2,0A 8×M12
- 16 DO DC 24V/1,3A 8×M12
- 8 DIO DC 24V/1,3A 8×M12
- 8 AI 4 U/I + 4 RTD/TC 8×M12
- 8 AI RTD/TC 8×M12
- 4 IO-L + 8 DI + 4 DO DC 24V/1,3A 8×M12

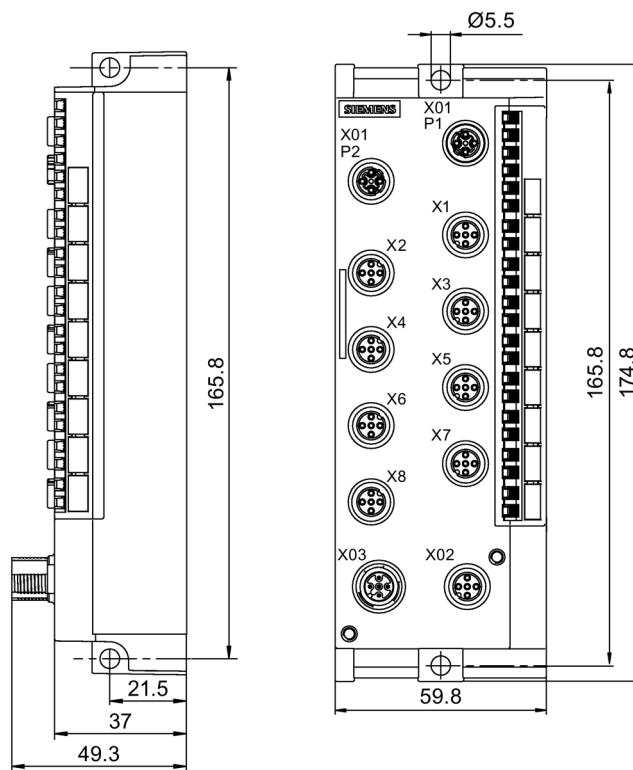

Dimensional drawing of the I/O devices of 60 mm width (with 4 I/O connectors)

The figure shows the dimensional drawing of the I/O devices:

- 4 AO U/I 4×M12

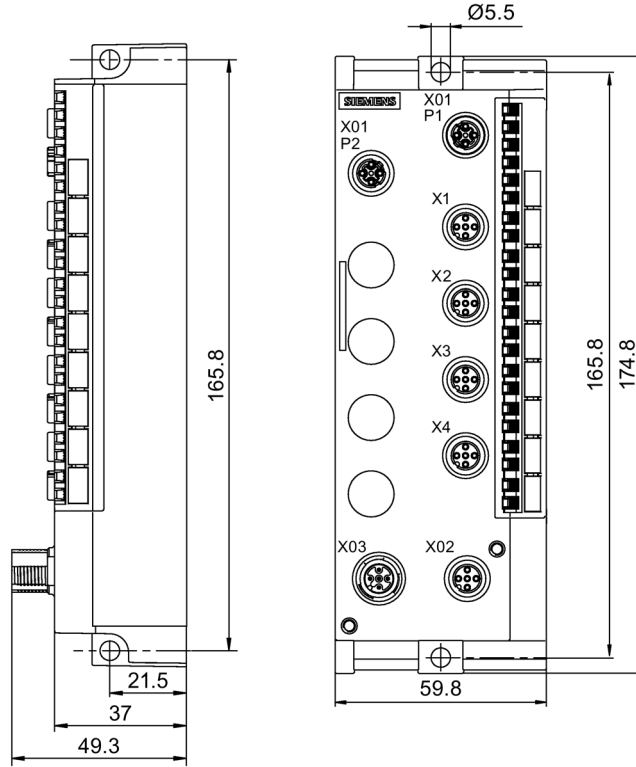

Dimensional drawing of the voltage distributor

The figure shows the dimensional drawing of the voltage distributor
PD DC 24V 1×7/8" 4×M12

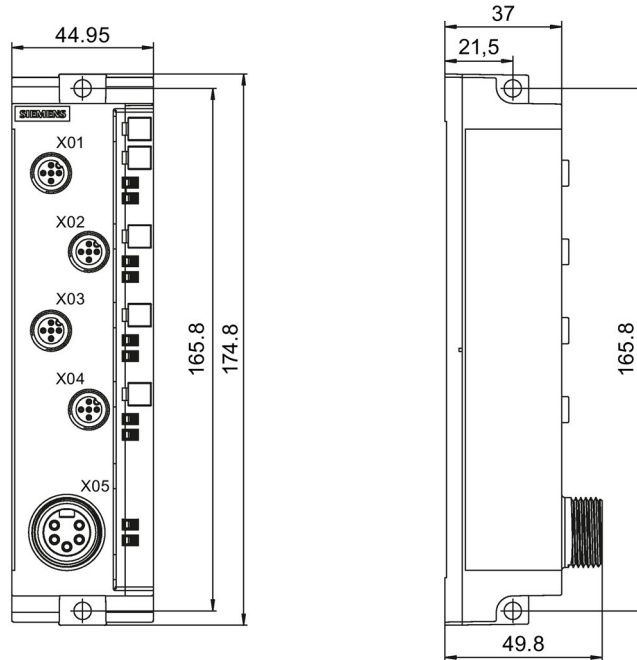

Dimensional drawing of the terminal block

The figure shows the dimensional drawing of the terminal block:

- Separately
- Installed on an I/O device

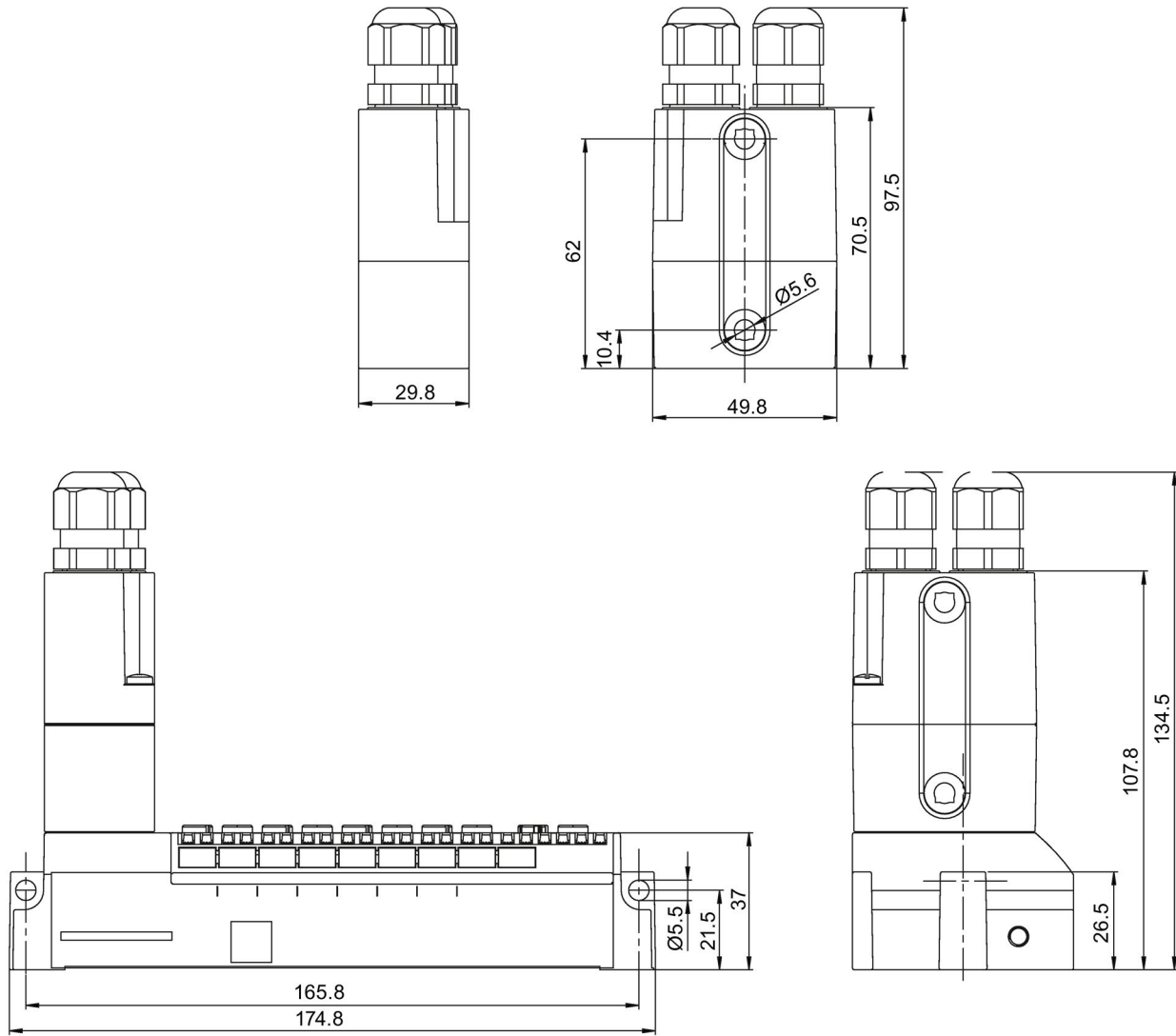

Dimensional drawing of the mounting rail

The figure shows the dimensional drawing of the mounting rail:

- Separately
- with an I/O device of 30 mm width
- with an I/O device of 60 mm width

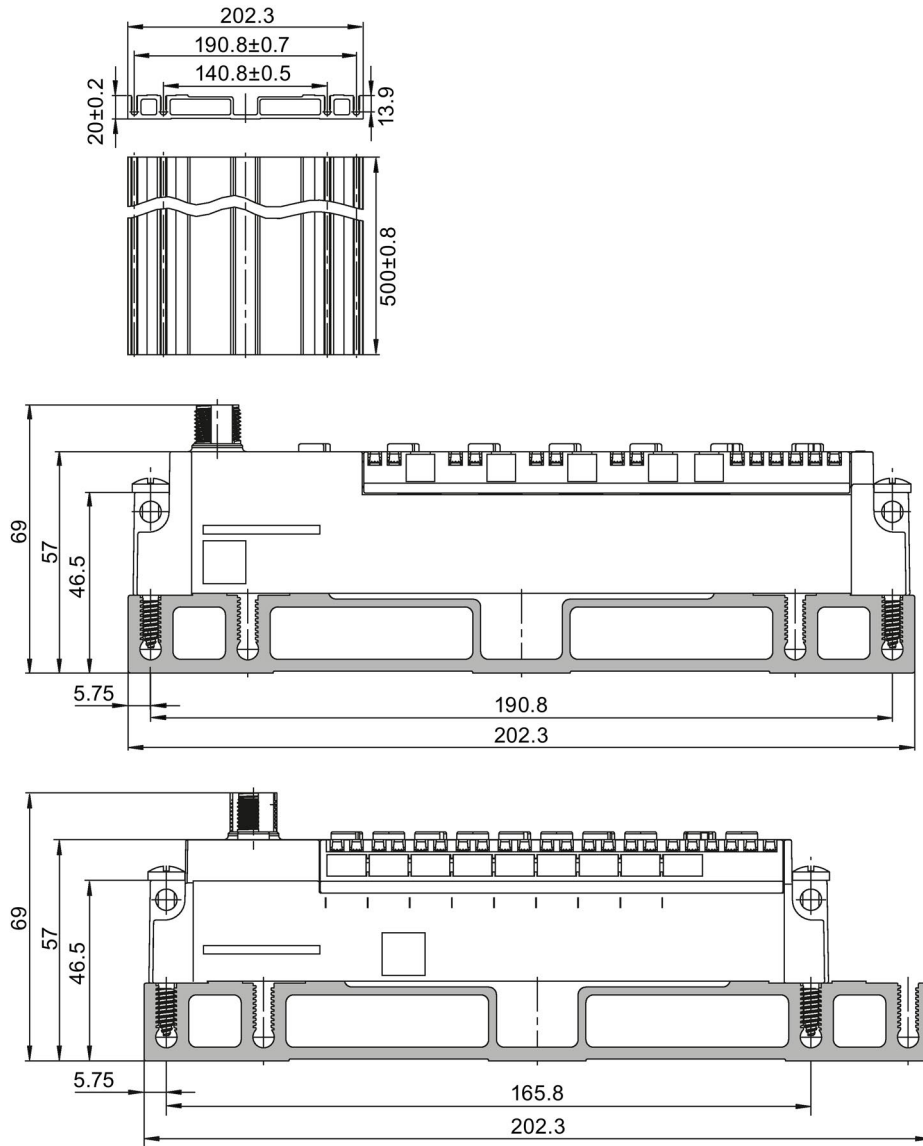

Connection examples

D.1 Connection of resistance thermometers to the analog inputs

Connection example 8 AI RTD/TC 8xM12

The figure below shows connection examples for 2-, 3- and 4-conductor connections.

2-conductor

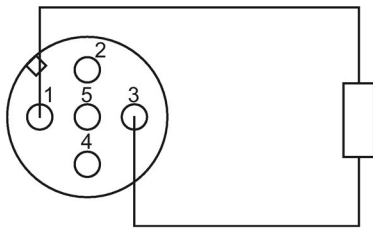

3-conductor

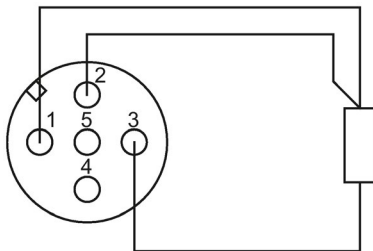

4-conductor

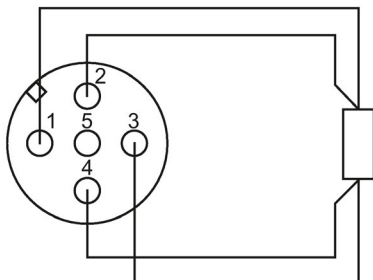

Figure D-1 Connection examples: 2-, 3- and 4-conductor

D.2 Connection of thermocouples to the analog inputs

Introduction

Different options are available for the analog I/O device 8 AI RTD/TC 8xM12 for compensation of the reference junction temperature. The corresponding connection examples are shown below. In practice, different connection variants may be possible due to the conditions on site.

Connection example "No" compensation as reference junction

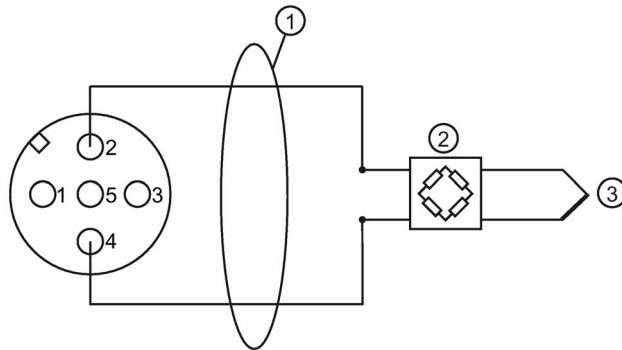

- ① Copper cables
- ② e. g. compensating box (per channel); thermocouple type B does not need a compensating box
- ③ Thermocouple

Figure D-2 Connection example "No" compensation as reference junction

Connection example "Internal" compensation or "Fixed reference temperature" as reference junction

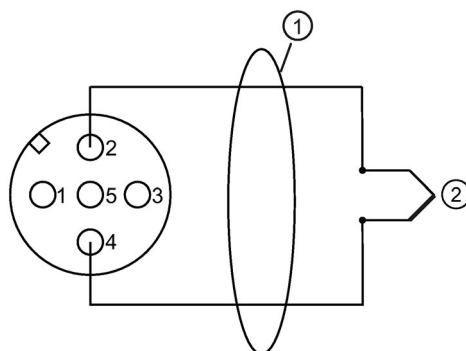

- ① Direct connection of the thermocouple or with compensating lines
- ② Thermocouple

Figure D-3 Connection example "Internal" compensation or "Fixed reference temperature" as reference junction

Connection example "RTD (0)" as reference junction

- With M12 compensation connector (integrated resistance thermometer Pt1000)

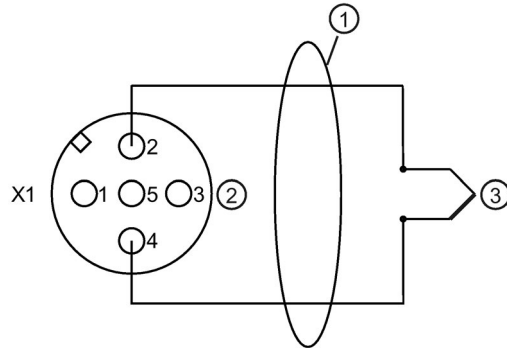

- ① Direct connection of the thermocouple or with compensating lines
- ② M12 compensation connector (terminals 1 and 3 assigned with internal Pt1000) only on round socket X1. The comparison value of the M12 compensation connector at round socket X1 also applies to thermocouples at X2, X3, X4, X5, X6, X7 and X8.
- ③ Thermocouple

Figure D-4 Connection example "RTD (0)" as reference junction in M12 compensation connector

- With external resistance thermometer Pt1000

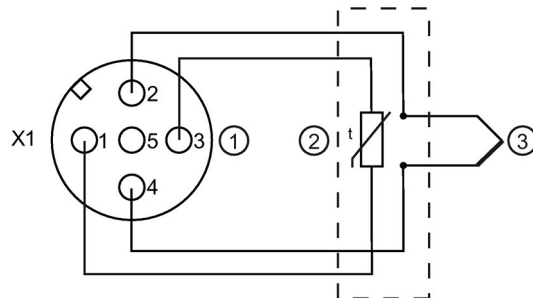

- ① M12 connector only on round socket X1
- ② External Pt1000 ($\alpha = 0.003851$) in the area of the reference junction with copper cables at terminals 1 and 3. The comparison value of the external Pt1000 at round socket X1 also applies to thermocouples at X2, X3, X4, X5, X6, X7 and X8.
- ③ Thermocouple

Figure D-5 Connection example "RTD (0)" as reference junction with external Pt1000

Connection example "Dynamic reference temperature" as reference junction

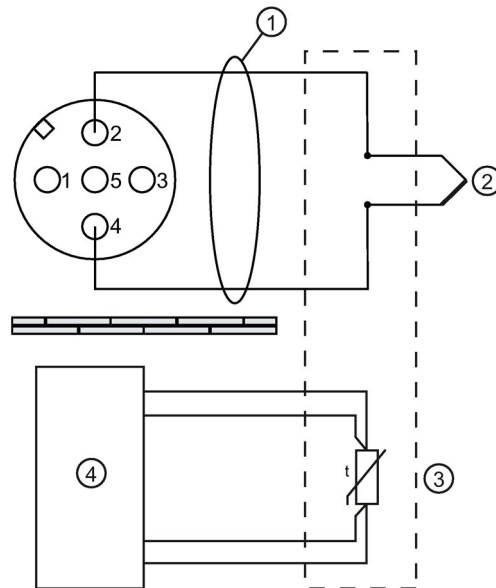

- ① Copper cables
- ② Thermocouple at 8 AI RTD/TC 8xM12
- ③ e. g. Pt100 in the area of the reference junction
- ④ RTD module of another station

Figure D-6 Connection example "Dynamic reference temperature" as reference junction

I/O address space

I/O device 8 DI DC 24V 4×M12

Assignment in the process image inputs per device:

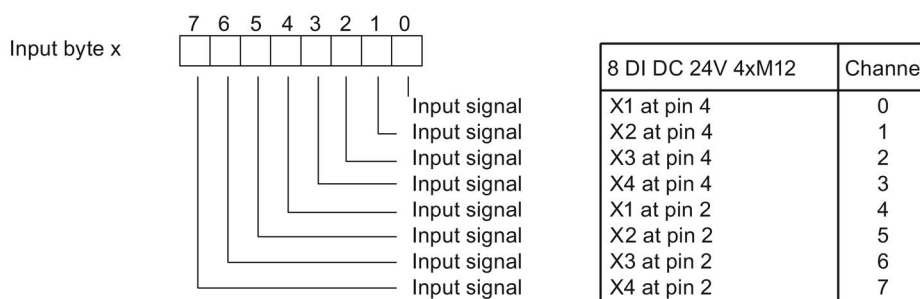

Figure E-1 Address space of 8 DI DC 24V 4×M12 I/O device

I/O device 8 DI DC 24V 8×M12

Assignment in the process image inputs per device:

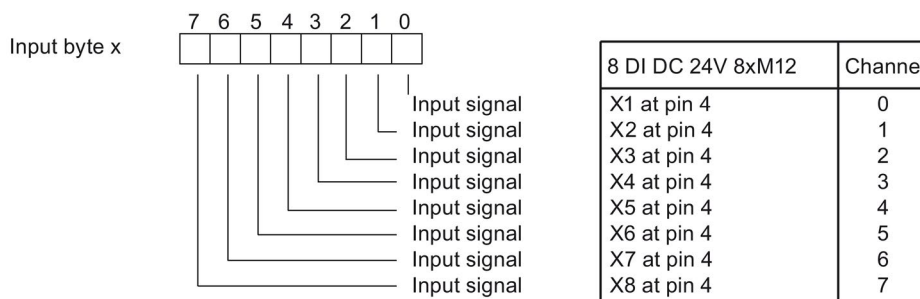

Figure E-2 Address space of 8 DI DC 24V 8×M12 I/O device

I/O device 16 DI DC 24V 8×M12

Assignment in the process image inputs per device:

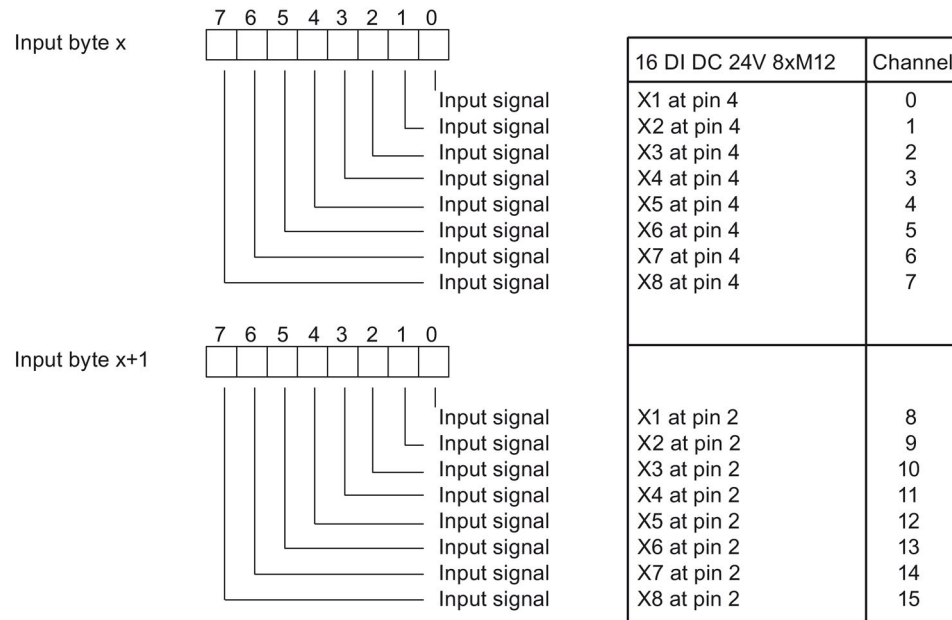

Figure E-3 Address space of 16 DI DC 24V 8×M12 I/O device

I/O device 8 DO DC 24V/1,3A 4×M12

Assignment in the process image output per device:

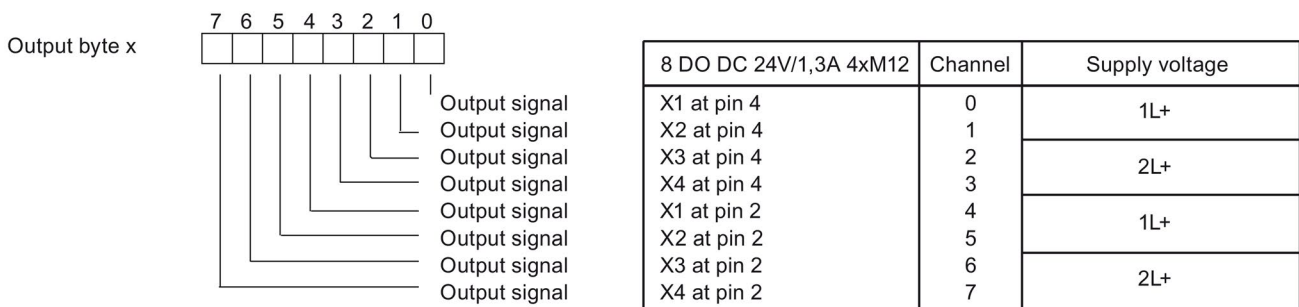

Figure E-4 Address space of 8 DO DC 24V/1,3A 4×M12 I/O device

I/O device 8 DO DC 24V/0,5A 4xM12

Assignment in the process image output per device:

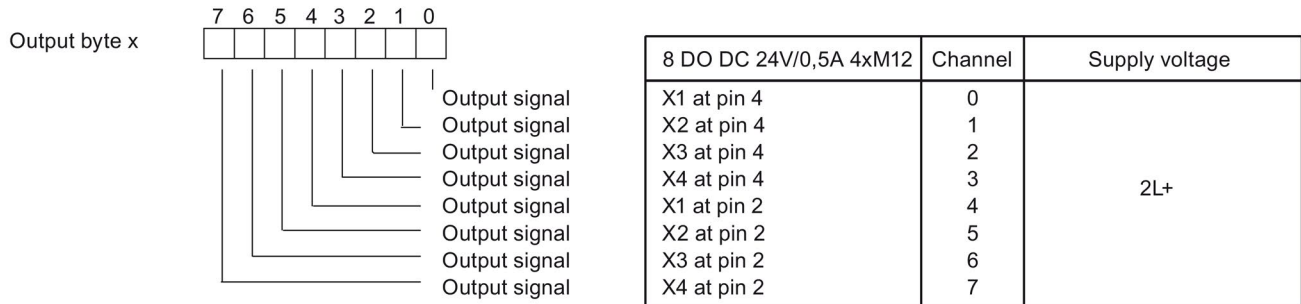

Figure E-5 Address space of 8 DO DC 24V/0,5A 4xM12 I/O device

I/O device 8 DO DC 24V/1,3A 8xM12 and 8 DO DC 24V/2,0A 8xM12

Assignment in the process image output per device:

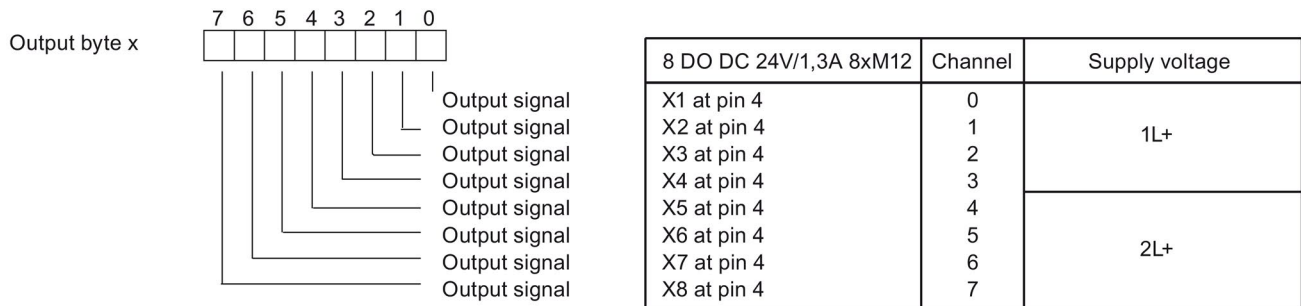

Figure E-6 Address space of I/O device 8 DO DC 24V/1,3A 8xM12 and 8 DO DC 24V/2,0A 8xM12

I/O device 16 DO DC 24V/1,3A 8×M12

Assignment in the process image output per device:

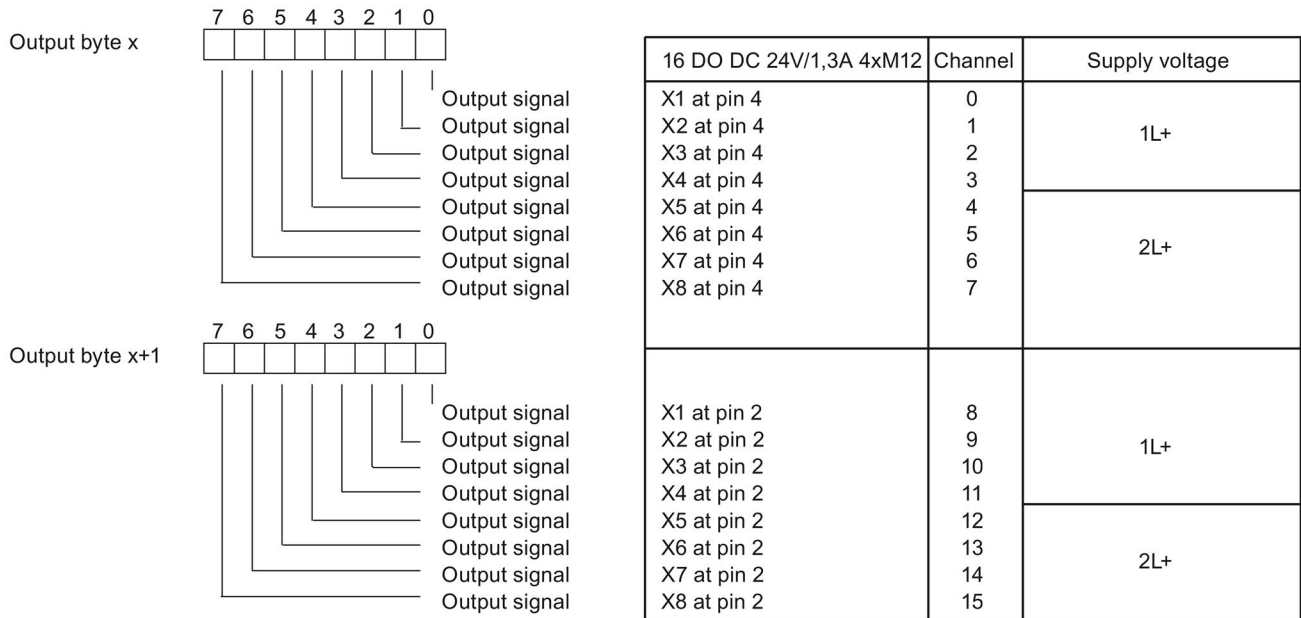

Figure E-7 Address space of 16 DO DC 24V/1,3A 8×M12 I/O device

I/O device 8 DIO DC 24V/1,3A 8×M12

Assignment in the process image inputs per device:

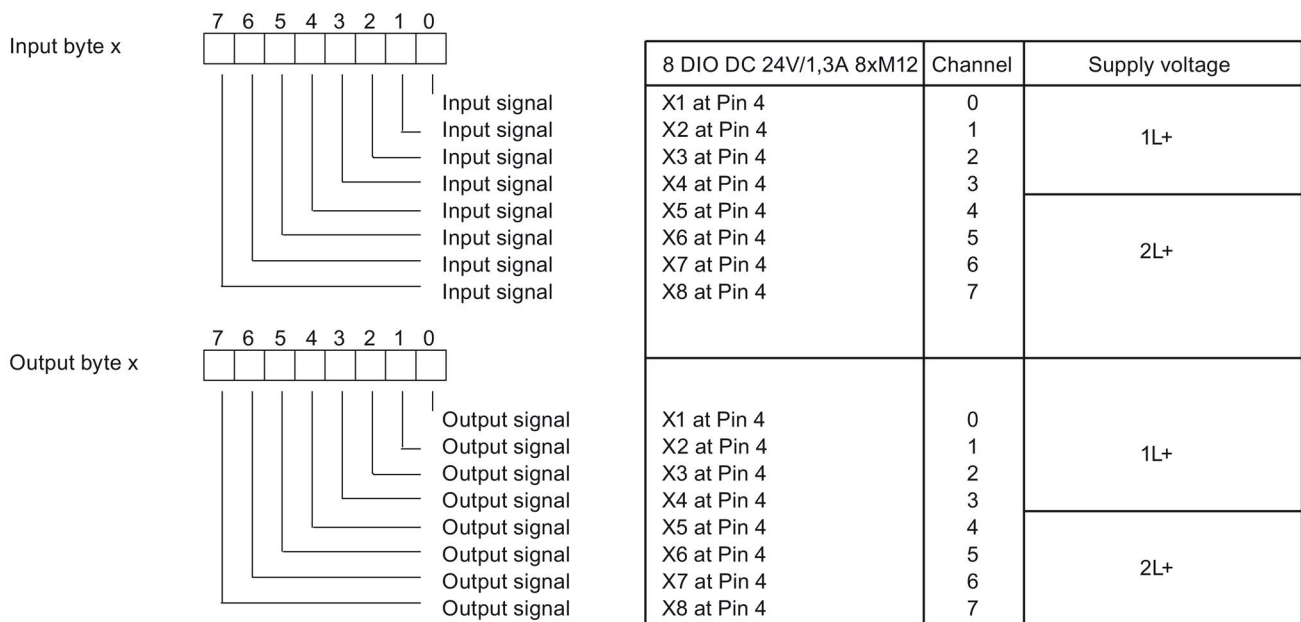

Figure E-8 Address space of 8 DIO DC 24V/1,3A 8×M12 I/O device

I/O device 8 AI 4 U/I + 4 RTD/TC 8×M12

Assignment in the process image inputs per device:

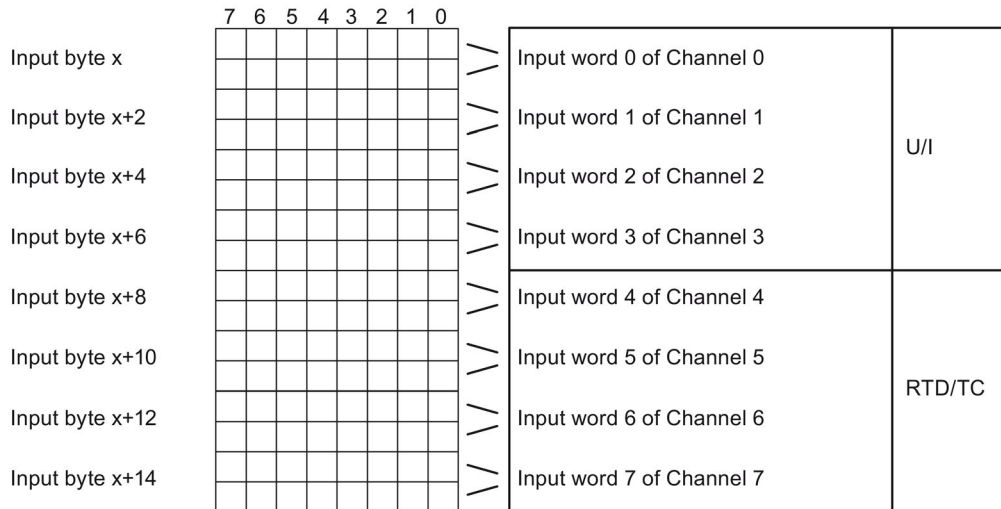

Figure E-9 Address space of 8 AI 4 U/I + 4 RTD/TC 8×M12 I/O device

I/O device 8 AI RTD/TC 8×M12

Assignment in the process image inputs per device:

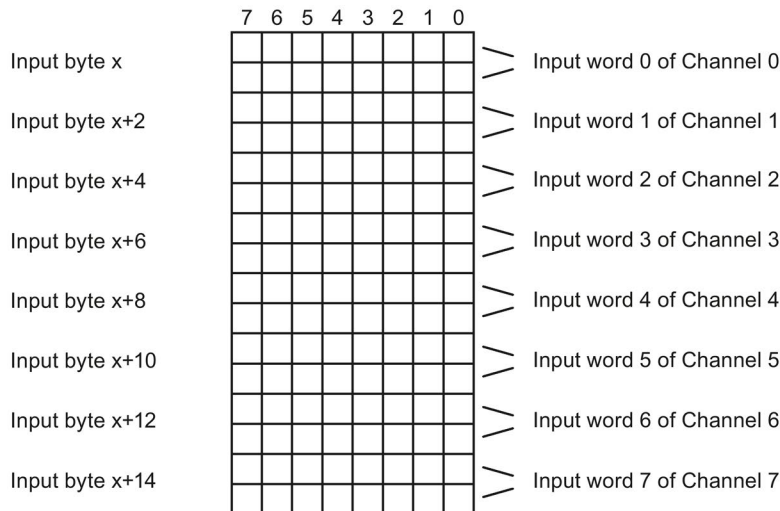

Figure E-10 Address space of 8 AI RTD/TC 8×M12 I/O device

I/O device 4 AO U/I 4×M12

Assignment in the process image output per device:

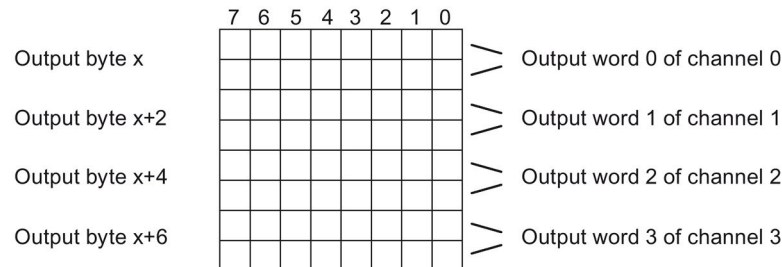

Figure E-11 Address space of 4 AO U/I 4×M12 I/O device

IO-Link Master 4 IO-L + 8 DI + 4 DO DC 24V/1,3A 8×M12

During the STEP 7 configuration, you can select the address space according to use.

During GSD configuration, Slot 1 "4 IO-L" has fixed 32 bytes input and 32 bytes output. Addressing of the input and output data can be selected freely using *S7-PCT*.

Note

Value status (PortQualifier)

The value status (PortQualifier) is disabled by default. An active value status (PortQualifier) is generally at byte x, bit 0 to bit 3. It can also be placed freely within the address space (byte x to x+32).

Assignment of the inputs and IO-Link channels as an example:

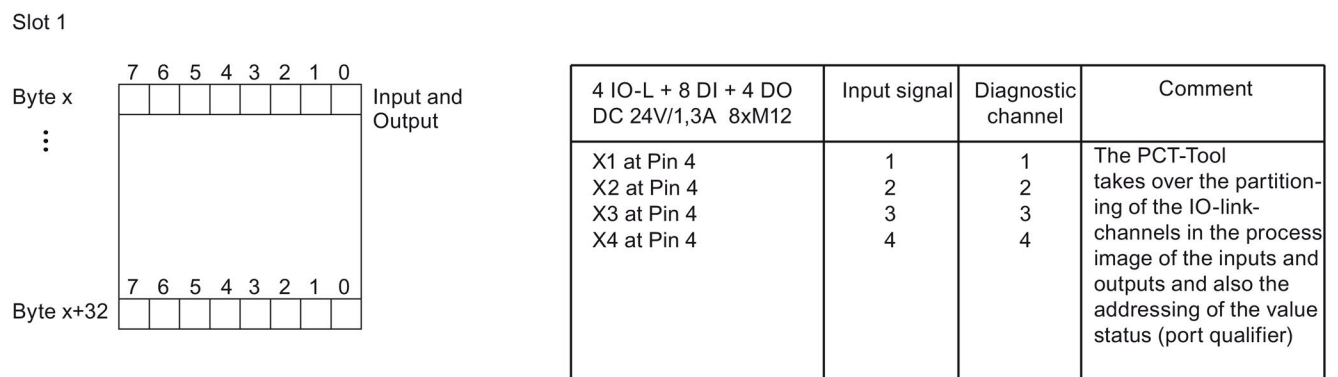

Figure E-12 Address space of the IO-Link channels of the IO-Link Master 4 IO-L + 8 DI + 4 DO DC 24V/1,3A 8×M12

Slot "8 DI + 4DO" has its own address space. The scope amounts to one byte inputs and one byte outputs.

Slot 2

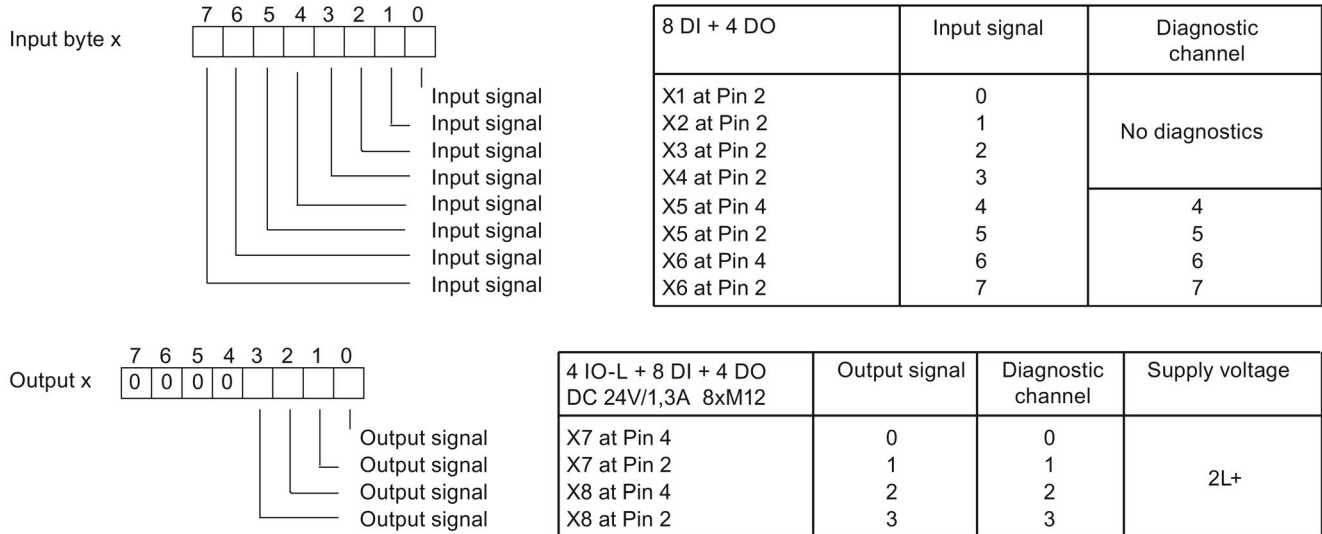

Figure E-13 Address space of the inputs and outputs of the IO-Link Master 4 IO-L + 8 DI + 4 DO DC 24V/1,3A 8xM12

IO-Link Master 4 IO-L 4xM12

During the configuration, you can select the address space according to use.

SIO mode

The following figures show the assignment of the address spaces of a submodule/port with the IO-Link Master 4 IO-L 4xM12, if you have configured the port as digital input or digital output in SIO mode.

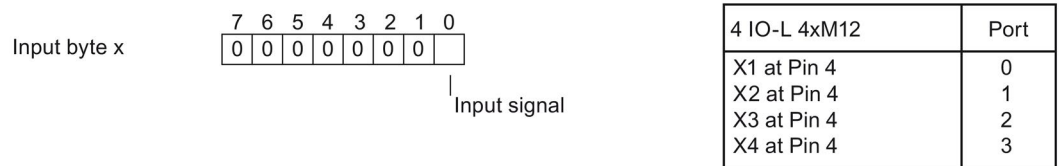

Figure E-14 Address space of the inputs of the IO-Link Master 4 IO-L 4xM12 in SIO mode

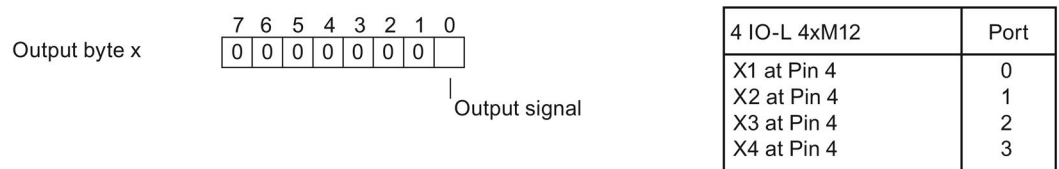
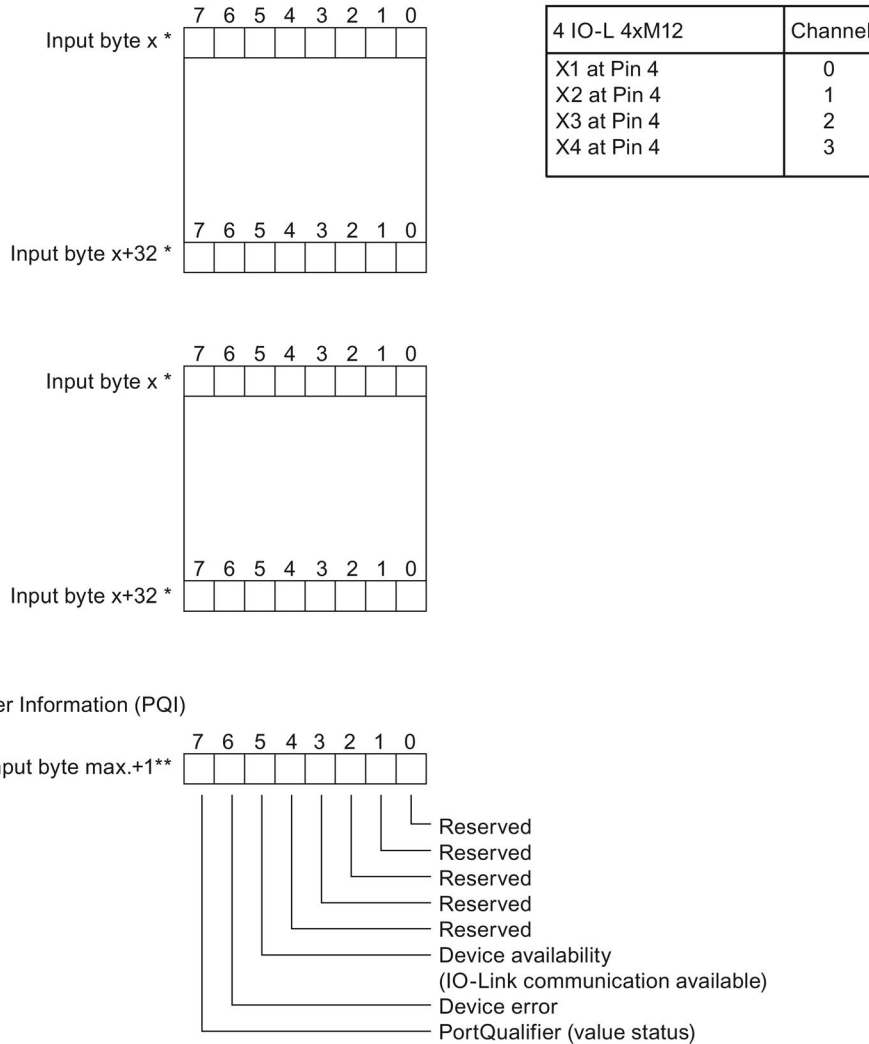

Figure E-15 Address space of the outputs of the IO-Link Master 4 IO-L 4xM12 in the SIO mode

IO-Link mode

The following figure shows the assignment of the address spaces of a submodule/port with the IO-Link Master 4 IO-L 4xM12, if you have configured the port in IO-Link mode.



* Detailed information on the assignment of the input and output bytes is available in the description of the IO-Link devices that are used.

** The PQI byte is always located behind the last input byte of the port. Depending on the configuration, the PQI byte is thus at byte 2, 3, 5, 9, 17 or 33 in the process input image.

Figure E-16 Address space of the inputs and outputs and of the PQI byte of the IO-Link Master 4 IO-L 4xM12 in IO-Link mode

Response times for analog input device and output device

F

F.1 Response times for analog input device

Conversion time

The basic conversion time depends directly on the conversion method of the analog input channel (integrating method, instantaneous value conversion). For the integrating conversion method, the integration time is included directly in the conversion time. The integration time depends on the interference frequency suppression.

For information on the basic conversion times and additional processing times of the individual analog devices, refer to the technical data of the corresponding analog I/O device.

Cycle time

The analog-digital conversion and the transfer of the digitized measured values to memory or to the backplane bus take place sequentially. In other words, the analog input channels are converted one after the other. The cycle time, that is, the time until an analog input value is converted again, is the sum of the conversion times of all the activated analog input channels of the analog input devices. You should deactivate unused analog input channels during parameter assignment in order to reduce the cycle time. The conversion and integration time for a deactivated channel is 0.

The figure below provides an overview of the cycle time elements of an n-channel analog input device.

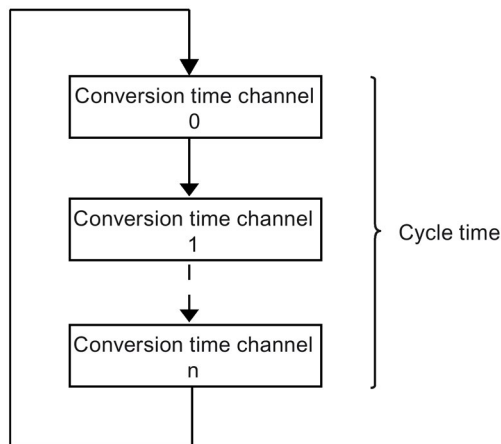

Figure F-1 Cycle time for analog input devices

Settling time

See *Smoothing*.

F.2 Response times for analog output device

Conversion time

The conversion time of the analog output channels includes the transfer of digitized output values from internal memory, and their digital-to-analog conversion.

Cycle time

The analog output channels are converted for the device with an execution time plus the sequential conversion time for channels 0, 1, 2, and 3.

The cycle time, i.e., the time until an analog output value is converted again, is the sum of the conversion times of all the activated analog output channels and of the processing time of the analog output device. You should deactivate unused analog output channels during parameter assignment in order to reduce the cycle time. The conversion time for a deactivated channel is 0 ms.

The following figure provides you with an overview of the cycle time elements for an analog output device.

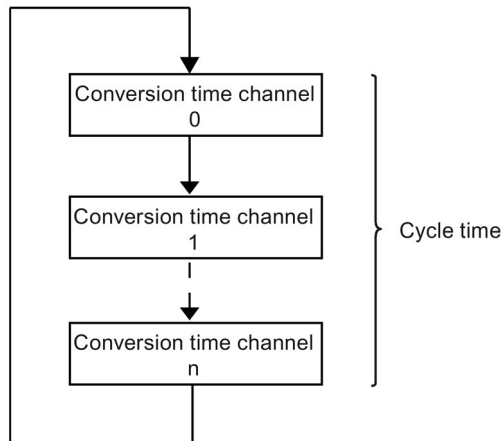

Figure F-2 Cycle time of analog output modules

Settling time

The settling time (t_2 to t_3)—that is, the time from the application of the converted value until the specified value is reached at the analog output—depends on the load. We therefore distinguish between resistive, capacitive, and inductive loads.

Response time

The response time (t_1 to t_3)—that is, the time from the application of the digital output values in internal memory until the specified value is reached at the analog output—is, in the most unfavorable case, the sum of the cycle time and the settling time. The worst case scenario is when the analog channel has been converted immediately before a new output value is transferred and is not converted again until all other channels have been converted (cycle time).

This figure shows the response time of an analog output channel:

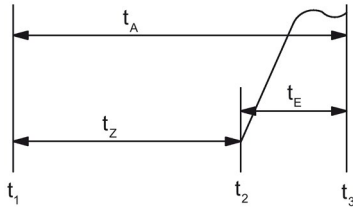

- t_A Response time
- t_Z Cycle time, corresponding to the processing time of the device and the conversion time of the channel
- t_E Settling time
- t_1 New digital output value applied
- t_2 Output value transferred and converted
- t_3 Specified output value obtained

Figure F-3 Response time of an analog output channel

Fail-safe shutdown of ET 200eco PN standard modules



G.1 Back-up oriented shutdown of ET 200eco PN standard modules

Introduction

The following structure describes how you can shutdown ET 200eco PN standard modules in a fail-safe manner.

Through the displayed structure (with the safety shutdown device: for example, 3TK28), all digital outputs that are connected to the supply 2L+ and 2M (24 V switched) from the ET 200eco PN standard modules are switched to the secure OFF state. Here the safety class SIL2/Category 3/PLd is reached.

Principle of operation

The higher-level safety shutdown device (e.g. 3TK28) disconnects the supplies 2L+ and 2M switched. The ET 200eco PN standard modules running on the supply 2L+ and 2M (24 V switched) and their digital outputs are switched to the safe state. The digital outputs connected to the supply 1L+ and 1M (24 V non-switched) are not intended for switching under normal operating conditions and cannot be safely shutdown.

There is no opposite influence of the outputs.

Block diagram

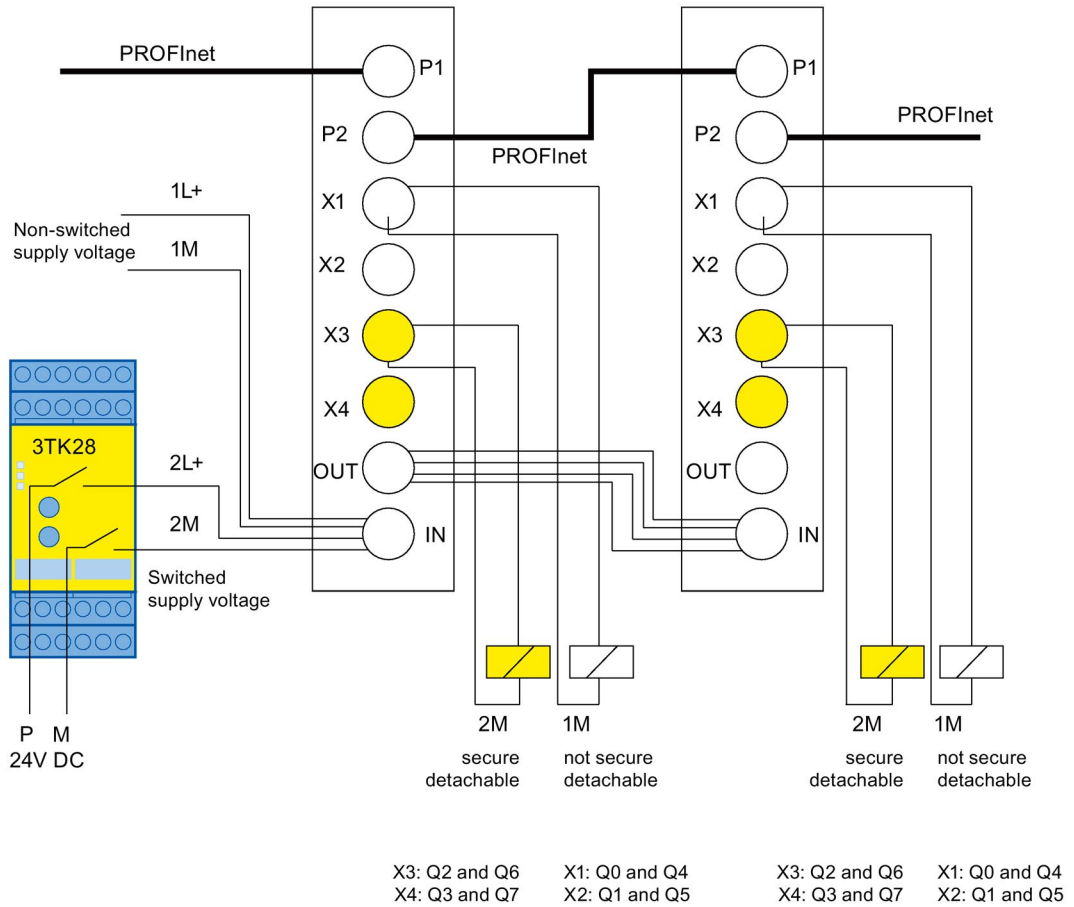

Figure G-1 Higher-level safety shutdown of the outputs

⚠ WARNING

If you use a pp-switching safety shutdown device, you have to lay the power supply cable to the connection of the ET 200eco PN modules in a manner secure against short-circuits. Note the EN 60204-1 standard, "Safely protected routing"!

Request TÜV certificate (report no. SA76041 T, revision 1.0 from 03.30.2010)

You can request copies of the TÜV certificate and the accompanying report at the following address:

Siemens Aktiengesellschaft
 Automation Technology Sector
 I IA AS R&D DH A3
 Postfach 1963
 D-92209 Amberg

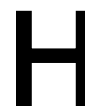

Open Source Software

H.1 Open Source Software

For Resellers: In order to avoid infringements of the license conditions by the reseller or the buyer, these notes and conditions and accompanying data carrier – if applicable - have to be forwarded to the buyers.

Please note:

This software is protected under Copyright Laws. Unauthorized usage of this software or parts of it may result in claims for damages and will be prosecuted according to criminal as well as civil law.

This software may only be used by authorized users who have a valid license to use this software. Such a license can have been acquired by entering into a license agreement with a Siemens company or an authorized third party supplier. Please read the license terms and conditions contained in your license agreement carefully before installing and using this software.

The license agreement together with a receipt, invoice or other purchase documentation will serve as proof that you have a valid license to use this software. Please keep such proof of your valid license in order to be able to present it in case of doubt. Any use without such license or outside of the granted scope is explicitly prohibited. If you do not have a valid license, please stop using the software immediately and contact your Siemens Company or your local supplier in order to avoid claims for damages against you or your company.

License Conditions and Disclaimers for Open Source Software and other Licensed Software

In the product "ET 200eco PN IO-Link Master 4xM12 - V1.0", Copyright Siemens AG, 2016 (hereinafter "Product"), the following Open Source Software is used either unchanged or in a form that we have modified, and additionally the other License Software noted below:

Liability for Open Source Software

Open Source Software is provided free of charge. We are liable for the Product including Open Source Software contained in accordance with the license conditions applicable to the Product. Any liability for use of Open Source Software beyond the program flow intended for the Product is explicitly excluded. Furthermore, any liability for defects resulting from modifications to the Open Source Software by you or third parties is excluded.

We do not provide any technical support for the Product if it has been modified.

Please note the following license conditions and copyright notices applicable to Open Source Software and other License Software:

Component	Open Source Software [Yes/No]	Acknowledgements	Copyright Information / File
OpenRTOS - 8.2	No		LICENSE AND COPYRIGHT INFORMATION FOR COMPONENT OPENRTOS - 8.2
TPS-1 FW-Stack - 1.3	No		LICENSE AND COPYRIGHT INFORMATION FOR COMPONENT TPS-1 FW-STACK - 1.3

LICENSE CONDITIONS AND COPYRIGHT NOTICES

Commercial Software: OpenRTOS - 8.2

Enclosed you'll find license conditions and copyright notices applicable for Commercial Software OpenRTOS - 8.2

License conditions:
- (N/A)

Copyrights:

Copyright (C) 1989, 1991 Free Software Foundation, Inc. 59 Temple Place, Suite 330, Boston, MA 02111-1307 USA
Copyright (C) 2015 Real Time Engineers Ltd. All rights reserved

LICENSE CONDITIONS AND COPYRIGHT NOTICES

Commercial Software: TPS-1 FW-Stack - 1.3

Enclosed you'll find license conditions and copyright notices applicable for Commercial Software TPS-1 FW-Stack - 1.3

License conditions:

Warranty Disclaimer */

/* */
/* Because the Product(s) is licensed free of charge, there is no warranty */
/* of any kind whatsoever and expressly disclaimed and excluded by NEC, */
/* either expressed or implied, including but not limited to those for */
/* non-infringement of intellectual property, merchantability and/or */
/* fitness for the particular purpose.
*/
/* NEC shall not have any obligation to maintain, service or provide bug */
/* fixes for the supplied Product(s) and/or the Application. */
/* */
/* Each User is solely responsible for determining the appropriateness of */
/* using the Product(s) and assumes all risks associated with its exercise */
/* of rights under this Agreement, including, but not limited to the risks */
/* and costs of program errors, compliance with applicable laws, damage
to */
/* or loss of data, programs or equipment, and unavailability or */
/* interruption of operations. */
/* */
/* Limitation of Liability */
/* */
/* In no event shall NEC be liable to the User for any incidental, */
/* consequential, indirect, or punitive damage (including but not limited */
/* to lost profits) regardless of whether such liability is based on breach */
/* of contract, tort, strict liability, breach of warranties, failure of */
/* essential purpose or otherwise and even if advised of the possibility of */
/* such damages. NEC shall not be liable for any services or products */
/* provided by third party vendors, developers or consultants identified or */
/* referred to the User by NEC in connection with the Product(s) and/or the
*/
/* Application.

Copyrights:

(C) 1996-2006 SEGGER Microcontroller Systeme GmbH Internet: www.segger.com
(c) 1995 - 2007 SEGGER Microcontroller Systeme www.segger.com
(c) 1995 - 2008 SEGGER Microcontroller GmbH & Co www.segger.com
(c) 1995 - 2012 SEGGER Microcontroller GmbH & Co KG www.segger.com
Copyright (C) ARM Limited, 2001. All rights reserved.

Copyright (C) NEC Corporation 2004 NEC CONFIDENTIAL AND PROPRIETARY All rights reserved by NEC Corporation.
Copyright (C) NEC Corporation 2004
Copyright (c) 2002 - ARM Ltd
Copyright (c) 2003 Altera Corporation, San Jose, California, USA. All rights reserved.
Copyright (c) 2003 Altera Corporation, San Jose, California, USA. All rights reserved.
Copyright (c) 2003, 2007 Altera Corporation, San Jose, California, USA. All rights reserved.
Copyright (c) 2003,2007 Altera Corporation, San Jose, California, USA. All rights reserved.
Copyright (c) 2003-2004 Altera Corporation, San Jose, California, USA. All rights reserved.
Copyright (c) 2003-2004 Altera Corporation, San Jose, California, USA. All rights reserved.
Copyright (c) 2003-2005 Altera Corporation, San Jose, California, USA. All rights reserved.
Copyright (c) 2003-2008 Altera Corporation, San Jose, California, USA. All rights reserved.
Copyright (c) 2003-2010 Altera Corporation, San Jose, California, USA. All rights reserved.
Copyright (c) 2004 Altera Corporation, San Jose, California, USA. All rights reserved.
Copyright (c) 2004-2005 Altera Corporation, San Jose, California, USA. All rights reserved.
Copyright (c) 2005 Altera Corporation, San Jose, California, USA. All rights reserved.
Copyright (c) 2006 Altera Corporation, San Jose, California, USA. All rights reserved.
Copyright (c) 2007 Altera Corporation, San Jose, California, USA. All rights reserved.
Copyright (c) 2007 Altera Corporation, San Jose, California, USA. All rights reserved.
Copyright (c) 2008 Altera Corporation, San Jose, California, USA. All rights reserved.
Copyright (c) 2008 Altera Corporation, San Jose, California, USA. All rights reserved.
Copyright (c) 2008 Altera Corporation, San Jose, California, USA. All rights reserved.
Copyright (c) 2008 by NEC Electronics (Europe) GmbH, a company of the NEC Electronics Corporation
Copyright (c) 2008 by NEC Electronics (Europe) GmbH, a company of the NEC Electronics Corporation
Copyright (c) 2009 Altera Corporation, San Jose, California, USA. All rights reserved.
Copyright (c) 2009 Altera Corporation, San Jose, California, USA. All rights reserved.
Copyright (c) 2009 Altera Corporation, San Jose, California, USA. All rights reserved.
Copyright 2001-2008 SEGGER Microcontroller GmbH & Co. KG. All rights reserved.
Copyright 2015 by Phoenix Contact Software GmbH
Copyright ARM Ltd 2001. All rights reserved.

Glossary

Autonegotiation

Configuration protocol in the Fast Ethernet. Before the actual data transmission, the devices on the network agree a transfer mode that each participating device can master (100 Mbps or 10 Mbps, full-duplex or half-duplex).

Baud rate

The speed at which data is transferred. It indicates the number of bits transferred per second (baud rate = bit rate).

Bus

Data transfer bus to which all nodes are connected. It has two defined ends.
ET 200 features a 2-wire bus.

Bus connector

Physical connection between the bus node and the bus cable.

Chassis ground

Chassis ground includes all the interconnected inactive parts of equipment that must not carry a hazardous voltage even in the event of a fault.

Device name

Because a fixed IP address is assigned to the device name, an IO Device must have a device name in order to be addressed by an IO Controller. With PROFINET, this procedure is used because names are easier to handle than complex IP addresses.

The assignment of a device name for a specific IO Device can be compared with the setting of the PROFIBUS address for a DP slave.

In the state of delivery a IO Device has no device name. The IO Device can only be addressed for an IO Controller after the device has been assigned a device name with the IO Supervisor/PC, for the transfer of configuration data (IP address and other data) during startup or for the exchange of user data in cyclic operation, for example.

Device replacement without removable media/programming device

I/O Devices having this function can be replaced easily:

- A removable medium (such as SIMATIC Memory Card) on which the device name is stored is not required.
- The device name does not have to be assigned using the programming device.

Instead of being assigned a device name from the removable medium or programming device, the I/O Device is now assigned a device name by the I/O Controller.

The I/O Controller uses the configured topology and the correlations derived from the I/O Devices. The configured target topology must agree with the actual topology.

Diagnostics

The detection, localization, classification, visualization and further evaluation of errors, disturbances and messages.

Provides monitoring functions which are executed automatically when the system is in RUN. Increases plant availability by reducing commissioning times and down times.

Distributed I/O systems

I/O systems that are not integrated into the central CPU rack, but rather at distributed remote locations. Example:

- ET 200M, ET 200X, ET 200L, ET 200S, ET 200 SP, ET 200pro, ET 200eco PN
- DP/AS-I Link
- S5-95U with PROFIBUS-DP slave interface
- Further DP slaves supplied by Siemens or other vendors.

Electrically isolated

The reference potentials of the control and load circuit of isolated I/O modules are electrically isolated, for example, by means of optocoupler, relay or transformer. I/O circuits may be connected to the same potential.

Equipotential bonding

Electrical connection (equipotential bonding conductor) that keeps electrical equipment and extraneous conductive objects to the same or almost the same potential in order to prevent disturbing or dangerous voltages between those objects.

Fast Ethernet

Fast Ethernet describes the standard for transferring data with 100 Mbps. This transfer technology used the 100 Base-T standard for this.

Firmware update

Updating the firmware of modules, for example, after functional enhancements to the latest firmware version (update).

Grounding

Refers to the bonding of conductive elements to ground via a grounding system.

GSD file

The properties of a PROFINET device are described in a GSD (Generic Station Description) file, which contains all required information for the configuration.

As with PROFIBUS, you can link a PROFINET device in STEP 7 by means of a GSD file.

In PROFINET IO, the GSD file is in XML format. The structure corresponds to ISO 15734, the worldwide standard for device descriptions.

Identification data

Information which is stored in modules and supports the user in checking the plant configuration and finding the hardware changes.

Industrial Ethernet

Industrial Ethernet (previously SINEC H1) is a technology that allows data to be transferred fail-safe in an industrial environment.

Standard Ethernet components can be used since PROFINET is an open system. However, we recommend setting up PROFINET as Industrial Ethernet.

IO-Link

IO-Link is a point-to-point connection to conventional and intelligent sensors/actuators via unshielded standard cable in proven 3-conductor technology. IO-Link is backwards compatible with all DI/DQ sensors/actuators. Circuit state channel and data channel designed in 24 VDC technology.

Non-isolated

The reference potentials of the control and load circuit of non-isolated I/O modules are electrically interconnected.

Parameter assignment

The term parameterization denotes the transfer of parameters from the IO Controller to the IO Device.

PELV

Protective Extra Low Voltage = extra low voltage with safe isolation

Prioritized startup

Prioritized startup (FSU) denotes PROFINET functionality for accelerating the startup of IO Devices for RT and IRT communication within a PROFINET IO system.

The functions reduce the time that the correspondingly configured IO Devices require to recover the cyclic exchange of user data in the following situations:

- After power has returned
- After station recovery
- After activation of IO Devices

Process image (I/O)

The CPU transfers the values from the input and output modules to this memory area. At the beginning of the cyclic program, the signal states of the input modules are transferred to the process input image. At the end of the cyclic program the process image of the outputs is transferred as a signal state to the output modules.

PROFIBUS

PROcess Field BUS, process- and fieldbus standard, which is defined in the standard IEC 61158 Type 3. It specifies functional, electrical and mechanical properties for a bit-serial fieldbus system.

PROFIBUS is available with the protocols DP (= Distributed Peripherals), FMS (= Fieldbus Message Specification), PA (= Process Automation), or TF (= Technological Functions).

PROFIBUS International

Technical committee dedicated to the definition and development of the PROFIBUS and PROFINET standard.

Also known as the PROFIBUS Trade Organization (PTO).

Homepage: www.profibus.com

PROFINET

Within the framework of Totally Integrated Automation (TIA), PROFINET represents a consequent enhancement of:

- PROFIBUS DP, the established field bus, and
- Industrial Ethernet, the communication bus for the cell level.

Experience gained from both systems was and is being integrated into PROFINET.

PROFINET is an Ethernet-based automation standard of PROFIBUS International (previously PROFIBUS Trade Organization) and defines a multi-vendor communication, automation and engineering model. Since 2003, PROFINET has been part of IEC 61158.

See PROFIBUS International

PROFINET component

A PROFINET component encompasses the entire data of the hardware configuration, the parameters of the modules, and the corresponding user program. The PROFINET component is composed of:

- Technological function

The (optional) technological (software) function includes the interface to other PROFINET components in the form of interconnectable inputs and outputs.

- Device

The device is the representation of the physical automation device or field device including the IO devices, sensors, actuators, mechanics, and device firmware.

PROFINET Device

All PROFINET devices are equipped with at least one Industrial Ethernet port. A PROFINET device can also have a PROFIBUS connection (master with proxy functionality).

PROFINET IO

Within the framework of PROFINET, PROFINET IO represents a communication concept for the implementation of modular, distributed applications.

PROFINET IO allows you to create automation solutions, which are familiar to you from PROFIBUS.

Implementation of PROFINET IO is effected on the one hand by means of the PROFINET standard for automation devices and on the other by means of the STEP 7 engineering tool. This means you have the same application view in STEP 7 regardless of whether you are configuring PROFINET devices or PROFIBUS devices. Programming your user program is essentially the same for PROFINET IO and PROFIBUS DP if you use the extended blocks and system status lists for PROFINET IO.

PROFINET IO Controller

Device used to address connected IO Devices. That means: the IO Controller exchanges input and output signals with assigned field devices. The IO Controller is usually the controller running the automation program.

PROFINET IO Device

Distributed field device which is assigned to one of the IO Controllers (remote IO, valve blocks, frequency converters, switches).

Reference potential

Reference potential for the evaluation / measuring of the voltages of participating circuits.

SELV

Safety Extra Low Voltage

SNMP

SNMP (Simple Network Management Protocol) is the standardized protocol for diagnostics and parameter assignment of the Ethernet network infrastructure.

In the office area and in automation technology, devices support a wide range of manufacturers on the Ethernet SNMP.

SNMP-based applications can be operated parallel to applications with PROFINET on the same network.

The scope of the supported functions varies depending on the device type. A switch, for example, has more functions than a CP 1616.

Switch

PROFIBUS is based on a line topology. Communication nodes are interconnected by means of a passive line, namely the bus.

By contrast, the Industrial Ethernet consists of point-to-point connections: Each communication node is interconnected directly with one other communication node.

If a communication node is to be interconnected with several other communication nodes, this communication node is connected to the port of an active network component, i.e., the switch. Other communication nodes (including switches) can then be connected to the other ports of the switch. The connection between a communication node and the switch remains a point-to-point connection.

The task of a switch is thus to regenerate and distribute received signals. The switch "learns" the Ethernet address(es) of a connected PROFINET device or of other switches and passes only the signals intended for the connected PROFINET device or switch.

A switch has a certain number of ports. Connect a maximum of one PROFINET device or one additional switch to each port.

TIA Portal

Totally Integrated Automation Portal

The TIA Portal is the key to the full performance capability of Totally Integrated Automation. The software optimizes all plant, machine and process sequences.

Total current

Total current of all output channels of a digital output module.

Index

"

Standards and Approvals",
Standards and Approvals",
Standards and Approvals",
Standards and Approvals",
Standards and Approvals",
Standards and Approvals",

1

16 DI DC 24V 8×M12
Block diagram, 117
Parameters, 120
Pin assignment, 117
Properties, 116
Technical data, 118
16 DO DC 24V/1,3A 8×M12
Parameters, 147
16 DO DC 24V/1.3A 8×M12
Block diagram, 142
Pin assignment, 141
Properties, 141
Technical data, 143

2

24 V DC supply, 29

4

4 AO U/I 4×M12
Block diagram, 196
Pin assignment, 196
Properties, 195
Technical data, 197
4 AO U/I 4×M12
Parameters, 201
4 IO-L + 8 DI + 4 DO DC 24V/1,3A 8×M12
Parameter, 214
4 IO-L 4×M12
Configuration, 222
Diagnostic interrupt, 226
Firmware update, 225
Functions, 224

Hardware interrupt, 227
Interrupts, 226
Master backup, 225
Parameter, 223
Port Qualifier Information, 224
PQI, 224
Pull/plug interrupt, 227
System diagnostics, 226

8

8 AI 4 U/I + 4 RTD/TC 8×M12
Block diagram, 157
Pin assignment, 155
Properties, 154
Technical data, 158
8 AI 4 U/I + 4 RTD/TC 8×M12
Parameters, 170
8 AI RTD/TC 8×M12
Block diagram, 165
Parameters, 173
Pin assignment, 164
Properties, 163
Technical data, 166
8 DI DC 24V 4×M12
Block diagram, 109
Parameters, 120
Pin assignment, 109
Properties, 108
Technical data, 110
8 DI DC 24V 8×M12
Block diagram, 113
Parameters, 120
Pin assignment, 112
Properties, 112
Technical data, 114
8 DIO DC 24V/1,3A 8×M12
Parameters, 153
8 DIO DC 24V/1.3A 8×M12
Block diagram, 149
Pin assignment, 149
Properties, 148
Technical data, 150
8 DO DC 24V/0,5A 4×M12
Parameters, 146
8 DO DC 24V/0.5A 4×M12
Block diagram, 127
Pin assignment, 127

- Properties, 126
 - Technical data, 128
 - 8 DO DC 24V/1,3A 4×M12
 - Parameters, 146
 - 8 DO DC 24V/1,3A 8×M12
 - Parameters, 146
 - 8 DO DC 24V/1.3A 4×M12
 - Block diagram, 123
 - Pin assignment, 122
 - Properties, 121
 - Technical data, 124
 - 8 DO DC 24V/1.3A 8×M12
 - Block diagram, 132
 - Pin assignment, 131
 - Properties, 131
 - Technical data, 133
 - 8 DO DC 24V/2,0A 8×M12
 - Parameters, 146
 - 8 DO DC 24V/2.0A 8×M12
 - Block diagram, 137
 - Pin assignment, 136
 - Properties, 135
 - Technical data, 138
- A**
- Additional support, 4
 - Address space
 - 16 DI DC 24V 8×M12, 251
 - 16 DO DC 24V/1.3 A 8×M12, 253
 - 4 AO U/I 4×M12, 255
 - 4 IO-L + 8 DI + 4 DO DC 24V/1,3A 8×M12, 255
 - 4 IO-L 4×M12, 256
 - 8 AI 4 U/I + 4 RTD/TC 8×M12, 254
 - 8 AI RTD/TC 8×M12, 254
 - 8 DI DC 24V 4×M12, 250
 - 8 DI DC 24V 8×M12, 250
 - 8 DIO DC 24V/1.3 A 8×M12, 253
 - 8 DO DC 24V/0.5 A 4×M12, 252
 - 8 DO DC 24V/1.3 A 4×M12, 251
 - 8 DO DC 24V/1.3 A 8×M12, 252
 - 8 DO DC 24V/2.0 A 8×M12, 252
 - Analog value, 182
 - Article numbers, 235
- B**
- Basic conversion time, 258
 - Basic knowledge, 3
 - Burst pulses, 102

C

- Climatic environmental conditions, 104
- Commissioning
 - ET 200eco PN, 77
- Components and protective measures, 31
- Components of ET 200eco PN, 13
- Configuring, 70
 - ET 200eco PN, 67
 - IO-Link master, 68, (HW Config), (GSD), (S7-PCT), 70
- Continuous shock, 105, 105
- Conversion time, 258, 259
- Cycle time, 258, 259

D

- Definition
 - Electromagnetic compatibility, 102
- Device identification, 71
- Device replacement without programming device, 74
- Diagnostics, 92
 - After IO Controller STOP, 98
 - After recovery of the IO Device, 98
- Diagnostics messages
 - PROFINET IO, 92
- Dimensional drawing, 240
- Disposal, 4
- Distributed I/O systems – application area, 10

E

- Electrical isolation
 - between..., 33
- Electromagnetic compatibility, 102
- Electrostatic discharge, 102
- EMC, 102
- EMERGENCY-STOP equipment, 29
- Emission of radio interference, 103
- Error types I/O devices, 94
- ET 200eco PN
 - Commissioning, 77
 - Components, 13
 - LED display, 85
 - Operation with grounded infeed, 30
- ET 200eco PN distributed I/O device
 - Definition, 12
 - Field of application, 12
 - IO Controller, 19
- ET 200eco PN standard modules
 - Fail-safe shutdown, 261
- Evaluating interrupts using an IO Controller, 83

Exchange object, 82

F

Firmware update

Online, 80

Flash test, 71

Function block

IO_LINK_DEVICE, 81

IO_LINK_MASTER, 81

Functional earth (FE), 35

G

General rules

For operation of an ET 200eco PN, 29

Grounded infeed, 30

GSDML file (PROFINET IO), 67

Guide, 4

H

HW Config, 67, 72

I

I/O device

Wiring, 37

I/O devices

Accessories, 236

Identification and maintenance data, 225

IEC 204, 29

Installing, 20

Insulation test, 107

IO controller

ET 200eco PN distributed I/O device, 19

IO Controller STOP

Diagnostics events triggered, 98

IO Device, 71

IO-Link Master

Functions, 216

IO-Link Master 4 IO-L + 8 DI + 4 DO DC 24V/1.3A
8×M12

Block diagram, 209

Pin assignment, 208

Properties, 207

Technical data, 210

IO-Link Master 4 IO-L 4×M12

Block diagram, 218

Pin assignment, 217

Properties, 217

Technical data, 219

IP address, 71

Isochronous real-time communication, 73

L

Labels, 27

LED display

ET 200eco PN, 85

IO-Link Master 4 IO-L + 8 DI + 4 DO DC 24V/1.3A
8×M12, 88

IO-Link Master 4 IO-L 4×M12, 89

Status, 89

Voltage distributor, 91

Loop-through

of PROFINET, 66

of the supply voltage, 66

M

M12 connector

connection, 37

Maintenance interrupts, 84

Manual

Purpose, 3

Measuring range

Current, 184, 184

Voltage, 182, 183, 204

Measuring ranges with SIMATIC S7, 182

Mechanical environmental conditions, 105

Media redundancy, 75

Mounting dimensions, 24

Mounting position, 24

O

Outdoors, 106

Overall configuration on TN-S system, 32

P

Parameter, 146, 214

Parameter assignment, 70

Parameters, 120, 153, 170, 173, 201

16 DI DC 24V 8×M12, 120

16 DO DC 24V/1,3A 8×M12, 147

4 AO U/I 4×M12, 201

4 IO-L + 8 DI + 4 DO DC 24V/1,3A 8×M12, 214

4 IO-L 4×M12, 223

- 8 AI 4 U/I + 4 RTD/TC 8xM12, 170
- 8 AI RTD/TC 8xM12, 173
- 8 DI DC 24V 4xM12, 120
- 8 DI DC 24V 8xM12, 120
- 8 DIO DC 24V/1,3A 8xM12, 153
- 8 DO DC 24V/0,5A 4xM12, 146
- 8 DO DC 24V/1,3A 4xM12, 146
- 8 DO DC 24V/1,3A 8xM12, 146
- PD DC 24V 1x7/8" 4xM12
 - Block diagram, 232
 - Pin assignment, 231
 - Properties, 231
 - Technical data, 233
- Pin assignment
 - 16 DI DC 24V 8xM12, 42
 - 16 DO DC 24V/1,3A 8xM12, 47
 - 4 AO U/I 4xM12, 58
 - 4 IO-L + 8 DI + 4 DO DC 24V/1,3A 8xM12, 49
 - 4 IO-L 4xM12, 51
 - 8 AI 4 U/I + 4 RTD/TC 8xM12, 52
 - 8 AI RTD/TC 8xM12, 55
 - 8 DI DC 24V 4xM12, 41
 - 8 DI DC 24V 8xM12, 42
 - 8 DIO DC 24V/1,3A 8xM12, 48
 - 8 DO DC 24V/0,5A 4xM12, 45
 - 8 DO DC 24V/1,3A 4xM12, 44
 - 8 DO DC 24V/1,3A 8xM12, 46
 - 8 DO DC 24V/2,0A 8xM12, 46
 - For loop-through of the supply voltage, 40
 - For supply voltage infeed, 40
 - Of the terminal block, 61
 - PROFINET connector, 39
 - Voltage distributor PD DC 24V 1x7/8, 64
- Pollution degree, 107
- Port, 72
- Prioritized startup, 74
- PROFINET IO, 10
 - Network topology, 11
- PROFINET IO Device, 71
- PROFINET IO standard, 99
- Protection against external electrical interference, 30
- Protection class, 107
- Pulse-shaped disturbances, 102

R

- Rated voltage, 107
- Readers of this manual, 4
- Reading diagnostics data, 92
- Recovery of the IO Device
 - Diagnostics events triggered, 98
- Recycling, 4

- Regulations
 - For operation of an ET 200eco PN, 29
- Removing, 28
- Replacing the fuse
 - Terminal block, 79
- Representation of analog values, 186, 187, 187, 188
- Reset to factory settings (PROFINET), 75
- Response time, 260

S

- Safe electrical isolation, 30, 31
- Safety shutdown device, 261
- Scope of information, 3
- Scope of this manual, 3
- SELV/PELV, 30
- Settling time, 259
- Shipping conditions, 102
- Shock, 105
- Signal names, 234
- SIMATIC Manual Collection, 239
- Sinusoidal disturbance variables, 102
- Smoothing, 178
- SNMP, 76
- Standards and certifications, 99
 - IEC 61131, 99
 - Operation in residential areas, 101
- Status display 24 V DC, 87
- STEP 7, 92
- Storage conditions, 102
- System startup after specific events, 29

T

- Technical data
 - Climatic environmental conditions, 104
 - Electromagnetic compatibility, 102
 - I/O device 16 DI DC 24V 8xM12, 118
 - I/O device 16 DO DC 24V/1,3A 8xM12, 143
 - I/O device 8 DI DC 24V 4xM12, 110
 - I/O device 8 DI DC 24V 8xM12, 114
 - I/O device 8 DIO DC 24V/1,3A 8xM12, 150
 - I/O device 8 DO DC 24V/0,5A 4xM12, 128
 - I/O device 8 DO DC 24V/1,3A 4xM12, 124
 - I/O device 8 DO DC 24V/1,3A 8xM12, 133
 - I/O device 8 DO DC 24V/2,0A 8xM12, 138
 - Shipping and storage conditions, 102
- Technical Support, 4
- Temperature, 103
- Temperature coefficient, 177

Terminal block
 Block diagram, 230
 Pin assignment, 229
 Properties, 229
 Technical data, 230
Test voltage, 107
TN-S system, 32
TÜV certificate, 262

V

Vibration, 105

W

Wiring
 For operation of an ET 200eco PN, 29

Y

Y cable, 38