

Synchronous motors 1FK7

Operating instructions · 03/2011



Synchronous Motors 1FK7

Operating Instructions

<u>Introduction</u>	1
<u>Safety instructions</u>	2
<u>Description</u>	3
<u>Preparing for use</u>	4
<u>Installation</u>	5
<u>Connecting</u>	6
<u>Commissioning</u>	7
<u>Operation</u>	8
<u>Maintenance</u>	9
<u>Decommissioning and disposal</u>	10
<u>Appendix</u>	A

Legal information

Warning notice system

This manual contains notices you have to observe in order to ensure your personal safety, as well as to prevent damage to property. The notices referring to your personal safety are highlighted in the manual by a safety alert symbol, notices referring only to property damage have no safety alert symbol. These notices shown below are graded according to the degree of danger.

 DANGER
indicates that death or severe personal injury will result if proper precautions are not taken.

 WARNING
indicates that death or severe personal injury may result if proper precautions are not taken.

 CAUTION
with a safety alert symbol, indicates that minor personal injury can result if proper precautions are not taken.

CAUTION
without a safety alert symbol, indicates that property damage can result if proper precautions are not taken.

NOTICE
indicates that an unintended result or situation can occur if the corresponding information is not taken into account.

If more than one degree of danger is present, the warning notice representing the highest degree of danger will be used. A notice warning of injury to persons with a safety alert symbol may also include a warning relating to property damage.

Qualified Personnel

The product/system described in this documentation may be operated only by **personnel qualified** for the specific task in accordance with the relevant documentation for the specific task, in particular its warning notices and safety instructions. Qualified personnel are those who, based on their training and experience, are capable of identifying risks and avoiding potential hazards when working with these products/systems.

Proper use of Siemens products

Note the following:

 WARNING
Siemens products may only be used for the applications described in the catalog and in the relevant technical documentation. If products and components from other manufacturers are used, these must be recommended or approved by Siemens. Proper transport, storage, installation, assembly, commissioning, operation and maintenance are required to ensure that the products operate safely and without any problems. The permissible ambient conditions must be adhered to. The information in the relevant documentation must be observed.

Trademarks

All names identified by ® are registered trademarks of the Siemens AG. The remaining trademarks in this publication may be trademarks whose use by third parties for their own purposes could violate the rights of the owner.

Disclaimer of Liability

We have reviewed the contents of this publication to ensure consistency with the hardware and software described. Since variance cannot be precluded entirely, we cannot guarantee full consistency. However, the information in this publication is reviewed regularly and any necessary corrections are included in subsequent editions.

Table of contents

1	Introduction	5
1.1	About these operating instructions	5
2	Safety instructions	7
2.1	General safety notes	7
2.2	Safety and application instructions	8
3	Description	11
3.1	Product description	11
3.2	Technical features.....	12
3.3	Rating plate (type plate).....	14
3.4	Design	15
3.4.1	Standards and regulations	15
3.4.2	Types of construction	15
3.4.3	Degree of protection	15
3.4.4	Ambient conditions.....	16
3.4.5	Cooling	16
3.4.6	Noise emission.....	17
4	Preparing for use	19
4.1	Shipping and packaging.....	19
4.2	Transport and storage.....	19
4.2.1	Transport.....	19
4.2.2	Storage.....	21
5	Installation	23
5.1	Installation.....	23
5.2	Attaching transmission elements	25
5.3	Vibration response	26
6	Connecting	27
6.1	Electrical connection	27
6.1.1	Safety instructions.....	27
6.1.2	Circuit diagram	28
6.1.3	Motor connection	28
6.1.4	Rotating the connector for 1FK7xxx5 and 1FK7xxx-7	32
6.1.5	Rotating the connector for 1FK7xxx-2, 1FK7xxx-3, 1FK7xxx-4.....	33
6.1.6	Motors with DRIVE-CLiQ interface	35
6.1.7	Motors without DRIVE-CLiQ interface	36
6.1.8	Connecting to a converter.....	36

7	Commissioning	37
7.1	Measures prior to commissioning	37
7.2	Switching on	39
8	Operation	41
8.1	Safety guidelines in operation	41
8.2	Faults	42
8.3	Non-operational periods	44
9	Maintenance	45
9.1	Inspection and maintenance	45
9.1.1	Safety instructions	45
9.1.2	Maintenance intervals	46
9.1.3	Bearing change interval	47
9.2	Repair	48
9.2.1	Safety instructions	48
9.2.2	Removing/Installing the encoder	49
10	Decommissioning and disposal	51
10.1	Decommissioning	51
10.1.1	Preparing for removal	51
10.1.2	Dismantling the motor	51
10.2	Disposal	52
A	Appendix	53
A.1	Order number Configuration Manual	53
A.2	Declaration of conformity	54
	Index	55

Introduction

1.1 About these operating instructions

These operating instructions describe the motor and explain how to handle the motor from the delivery up to disposal.

Before you start to handle the motor, you must read these operating instructions. to ensure safe, problem-free operation and to maximize the service life.

These operating instructions are valid in conjunction with the relevant SIEMENS Configuration Manual.

Siemens continually strives to improve the quality of information provided in these operating instructions. If you find any mistakes or would like to offer suggestions about how this document could be improved, please contact the Siemens Service Center.

Always follow the safety instructions and notices in these operating instructions. The warning notice system is explained on the rear of the inside front.

Text format features

In addition to the safety-related notices and instructions that you must carefully observe, you will find the text in these operating instructions is formatted in the following way:

1. Handling instructions are always shown as a numbered list. Always perform the handling steps in the sequence given.
- Lists are formatted as bulleted lists.
 - Lists at the second level are hyphenated.

Note

A Note is an important item of information about the product, handling of the product or the relevant section of the document. Notes provide you with help or further suggestions/ideas.

Safety instructions

2.1 General safety notes

Safety and commissioning information for converter-fed low-voltage three-phase motors

 DANGER

All activities associated with transporting, connecting, commissioning, and maintaining the motors must be carried out by properly trained, responsible personnel (observe DIN EN 50110-1; IEC 60364).
--

Failure to follow proper procedures may result in injury or material damage.
--

Special versions and design versions may differ with respect to certain technical aspects. If in doubt, you are strongly advised to contact the manufacturer, specifying the type designation and serial number (see rating plate), or arrange for any maintenance work to be carried out by the SIEMENS Service Center.

Systems and machines with converter-fed low-voltage three-phase motors must fulfill the protective requirements of the EMC Directive.

The machine manufacturer is responsible for ensuring that installation is carried out properly. The signal and power cables to the motor must be shielded.

The information provided by the converter manufacturer regarding EMC-compliant installation must be observed.

Intended use

These motors are designed for use in industrial or commercial systems. They comply with the EN 60034-1 standards and the relevant associated sections.

 WARNING
--

It is forbidden to install them in hazardous areas unless they are explicitly designed for this.
--

If more stringent requirements are necessary in special cases (e.g. shock-hazard protection in non-commercial applications where children are likely to be present), the customer must implement the relevant measures to ensure that these requirements are fulfilled.

Any alternative data specified on the rating plate must be taken into account. The conditions at the installation location must comply with the rating plate specifications.

The motors are designed for use in sheltered areas under normal climatic conditions, such as those found in production environments.

2.2 Safety and application instructions

The safe use of electrical machines

 WARNING
Rotating or live parts Rotating or live parts are dangerous. Fatal or severe injuries and substantial material damage can occur if the necessary covers are removed or if the machines are not handled, operated, or maintained properly. Covers must only be removed and the motor operated in accordance with the relevant regulations. The motor must be maintained on a regular basis.

Qualified personnel

These operating instructions only contain the information necessary for ensuring that the motor is operated by properly trained personnel in accordance with its intended purpose.

Those responsible for plant safety must ensure the following:

- The basic planning work for the plant or system and all work relating to transportation, assembly, installation, commissioning, maintenance and repairs is carried out by qualified personnel and checked by responsible, suitably skilled personnel.
- The operating instructions and the motor documentation are available at all times.
- The technical data and specifications relating to installation, connection, ambient and operating conditions are taken into account at all times.
- The system-specific installation and safety regulations are observed.
- Personal protective equipment is used.
- Unqualified persons must not work on or in the vicinity of these motors at any time.
- If the motors are used outside industrial areas, the installation site must be protected against unauthorized access by means of suitable protective measures (e.g. safety fences and warning signs).

Note

Siemens Service Center

For any service work you may require, you are advised to contact your nearest Siemens Service Center to request their services and support for maintenance activities.

Observing the five safety rules

For your personal safety and to prevent material damage when working on the machine, always observe the safety instructions and the following five safety rules. Apply the five safety rules in the order stated before starting work at the machine.

1. Isolate the equipment from the power supply
You must also make sure that the auxiliary circuits are also disconnected.
2. Protect against reconnection.
3. Make sure that the equipment is de-energized and in a no-voltage condition.
4. Ground and short-circuit
5. Cover or enclose adjacent components that are still live.

After the work has been completed, undo the previous measures in the reverse order.

Thermal hazard

 CAUTION
<p>The surface temperature of the motors can exceed 100 °C.</p> <p>Do not touch hot surfaces!</p> <p>Temperature-sensitive components (electric cables, electronic components) must not be placed on hot surfaces. If the motors overheat, this can destroy the windings/bearings and permanent magnets may become demagnetized.</p> <p>Only operate the motors in conjunction with effective temperature monitoring!</p>

Notes about electromagnetic fields

 **WARNING**

Electromagnetic fields

Electromagnetic fields are generated by the operation of electrical power equipment – such as transformers, converters or motors.

Electromagnetic fields can destroy electronic devices, which could cause them to malfunction. For example, the operation of heart pacemakers can be impaired, potentially leading to personal injury or even death. It is therefore forbidden for persons with heart pacemakers to enter these areas.

The company operating the plant is responsible for taking appropriate measures (labels and hazard warnings) to adequately protect operating personnel and others against any possible risk.

- Observe the relevant local and domestic health and safety regulations. In Germany, "electromagnetic fields" are subject to regulations BGV B11 and BGR B11 stipulated by the German statutory industrial accident insurance institution.
- Display adequate hazard warning notices.
- Place barriers around hazardous areas.
- Take measures, e.g. using shields, to reduce electromagnetic fields at their source.

Description

3.1 Product description

Overview

1FK7 motors are compact permanent-magnet synchronous motors. The available options, gear units and encoders, together with the expanded product range, mean that the 1FK7 motors can be optimally adapted to any application. They therefore also satisfy the permanently increasing demands of state-of-the-art machine generations.

1FK7 motors can be combined with the SINAMICS S120 drive system to create a high-performance system with a high degree of functionality. The integrated encoder systems for speed and position control can be selected depending on the application.

The motors are designed for operation without external ventilation as the heat is dissipated through the motor surface. 1FK7 motors have a high overload capability.

Benefits

1FK7 Compact motors offer:

- Space-saving installation thanks to extremely high power density
- Can be universally used for many applications
- Wide range of motors

1FK7 High Inertia motors offer:

- Rugged closed-loop control properties for high or variable load moments of inertia
- Low optimization and commissioning overhead to compensate disturbances

Applications

- Machine tools
- Robots and handling systems
- Wood, glass, ceramics and stone working
- Packaging, plastics and textile machines
- Auxiliary axes

3.2 Technical features

Table 3- 1 Technical features

Type of motor	Permanent-magnet synchronous motor
Magnet material	Rare-earth magnetic material
Cooling	Natural cooling
Insulation of the stator winding according to EN 60034-1 (IEC 60034-1)	Temperature class 155 (F) for a winding temperature of $\Delta T = 100$ K at an ambient temperature of $+40^\circ$ C
Installation altitude (in accordance with EN 60034-1 and IEC 60034-1)	≤ 1000 m above sea level, otherwise power derating
Type of construction in accordance with EN 60034-7 (IEC 60034-7)	IM B5 (IM V1, IM V3)
Degree of protection in accordance with EN 60034-5 (IEC 60034-5) ¹⁾	IP64; optional IP65 or IP65 + IP67 at the shaft gland
Temperature monitoring	KTY 84 temperature sensor in the stator winding
Paint finish	Anthracite (RAL 7016)
Drive shaft end acc. to DIN 748-3 (IEC 60072-1)	Plain shaft, optional shaft with fitted key and keyway (half-key balancing)
Radial eccentricity, concentricity and axial eccentricity acc. to DIN 42955 (IEC 60072-1) ²⁾	Tolerance N (normal)
Vibration severity grade according to EN 60034-14 (IEC 60034-14)	Grade A is maintained up to rated speed
Sound pressure level L_{pA} (1 m) in accordance with DIN EN ISO 1680, max. tolerance + 3 dB(A)	<ul style="list-style-type: none"> • 1FK701□ to 1FK704□: 55 dB(A) • 1FK706□: 65 dB(A) • 1FK708□ to 1FK710□: 70 dB(A)
Built-in encoder systems for motors without DRIVE-CLiQ interface	<ul style="list-style-type: none"> • IC2048S/R³⁾ incremental encoder, sin/cos 1 Vpp, 2048 S/R³⁾ with C and D tracks, for SH 20 to SH 100 • AM2048P/R³⁾ absolute encoder 2048 P/R³⁾, 4096 revolutions multiturn, with EnDat interface for SH 36 to SH 100 • AM512P/R³⁾ absolute encoder 512 P/R³⁾, 4096 revolutions multiturn, with EnDat interface for SH 28 • AM16P/R³⁾ absolute encoder 16 P/R³⁾, 4096 revolutions multiturn, with EnDat interface for SH 20 and SH 28 • Resolver multi-pole (number of poles corresponds to number of pole pairs of the motor), for SH 20 and SH 28 • 2-pole resolver for SH 20 and SH 28

Integrated encoder systems for motors with DRIVE-CLiQ interface	<ul style="list-style-type: none"> • AS24DQI absolute encoder single-turn 24 bit , for SH 36 to SH 100 • AM24DQI absolute encoder 24 bit + 12 bit multiturn, for SH 36 to SH 100 • AS20DQI absolute encoder single-turn 20 bit, for SH 36 to SH 100 • AM20DQI absolute encoder 20 bit + 12 bit multiturn, for SH 36 to SH 100 • IC22DQ incremental encoder 22 bit + commutation position, 11 bit, for SH 20 to SH 100 • AM22DQI absolute encoder 22 bit + 12 bit multiturn, for SH 36 to SH 100 • AM20DQ absolute encoder 20 bit + 12 bit multiturn, for SH 28 • AM15DQ absolute encoder 15 bit + 12 bit multiturn, for SH 28 • R15DQ resolver 15 bit, for SH 28 • R14DQ resolver 14 bit, for SH 28
Connecting	Connectors for signals and power, can be rotated
Holding brake	<ul style="list-style-type: none"> • Optional mounted holding brake (free of backlash, 24 V)
Second rating plate	<ul style="list-style-type: none"> • Enclosed separately

- 1) 1FK701 only available in degree of protection IP54 with paint finish, planetary gearbox not possible
- 2) Radial eccentricity of the shaft extension, concentricity of centering edge and axial eccentricity of the mounting flange to the axis of the shaft extension.
- 3) P/R = Pulses/Revolution

3.3 Rating plate (type plate)

The rating plate (type plate) contains the technical data relevant for the motor.

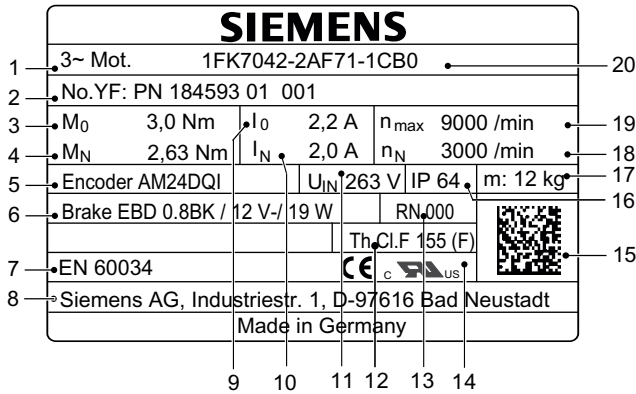

Figure 3-1 Schematic layout of rating plate

Table 3-2 Description of the rating plate data

Position	Description / technical data
1	Motor type: Synchronous motors
2	ID no., serial number
3	Static torque M_0 [Nm]
4	Rated torque M_N [Nm]
5	Designation of the encoder type
6	Holding brake data: Typical, voltage, power consumption
7	Standard for all rotating electrical machines
8	Production address
9	Stall current I_0 [A]
10	Rated current I_N [A]
11	Induced voltage at rated speed U_{IN} [V]
12	Temperature class
13	Motor version
14	Standards and specifications
15	2D code
16	Degree of protection
17	Motor weight m [kg]
18	Rated speed n_N [rpm]
19	Maximum speed n_{max} [rpm]
20	SIEMENS motor type/order number

3.4 Design

3.4.1 Standards and regulations

The motors comply with the following regulations according to IEC / EN 60034:

Table 3- 3 Regulations that have been applied

Feature	Standard
Ratings and operating performance	IEC/EN 60034-1
Degree of protection ⁽¹⁾	IEC/EN 60034-5
Type of construction ⁽¹⁾	IEC/EN 60034-7
Terminal markings	IEC/EN 60034-8
Noise emission	IEC/EN 60034-9
Temperature monitoring	IEC/EN 60034-11
Vibration severity levels	IEC/EN 60034-14

⁽¹⁾ The degree of protection and type of construction of the motor are stamped on its rating plate.

The three-phase motors comply with the relevant sections of EN 60034 and EN 60204-1. Three-phase motors comply with the Low-Voltage Directive 2006/95/EC. Motors which have "UR" stamped on their rating plates comply with UL regulations.

Low-voltage motors are components designed for installation in machines in accordance with the Machinery Directive. They must not be commissioned until it has been verified that the end product complies with this directive (also take into account EN 60204-1).

Note

Make sure that your end product is in compliance with all of the applicable laws! The applicable domestic, local, and system-specific regulations and requirements must be taken into account.

3.4.2 Types of construction

The motor has type construction IM B5 (IM V1, IM V3).

3.4.3 Degree of protection

1FK7 motors are available with IP64 or IP65 degree of protection. The degree of protection of the motor is specified on the rating plate.

3.4.4 Ambient conditions

The following temperature ranges apply to naturally-cooled motors.

- Permissible temperature range in operation: T = -15 °C to +40 °C
- Permissible temperature range during storage: T = -20 °C to +70 °C

For deviating conditions (ambient temperature > 40°C or installation altitude > 1000 m above sea level) the permissible torque/power must be determined from the following table. Ambient temperatures and installation altitudes are rounded off to 5°C and 500 m respectively.

Table 3- 4 Power derating as a function of the installation altitude and ambient temperature

Installation altitude above sea level [m]	Ambient temperature in °C				
	< 30	30 - 40	45	50	55
1000	1.07	1.00	0.96	0.92	0.87
1500	1.04	0.97	0.93	0.89	0.84
2000	1.00	0.94	0.90	0.86	0.82
2500	0.96	0.90	0.86	0.83	0.78
3000	0.92	0.86	0.82	0.79	0.75
3500	0.88	0.82	0.79	0.75	0.71
4000	0.82	0.77	0.74	0.71	0.67

NOTICE
What has to be observed when installing the motors
1FK7 motors are not suitable for operation
<ul style="list-style-type: none"> • in salt-laden or corrosive atmospheres • outdoors

3.4.5 Cooling

Natural cooling

The rated data only applies when the ambient temperature does not exceed 40 °C (104 °F) as a result of the installation conditions.

To ensure sufficient cooling, a minimum clearance of 100 mm from adjacent components must be observed at three lateral surfaces.

3.4.6 Noise emission

When operated in the speed range 0 to rated speed, 1FK7 motors can reach the following measuring-surface sound pressure level $L_p(A)$:

Table 3- 5 Sound pressure level

Shaft height	Measuring-surface sound pressure level $L_p(A)$
1FK701 to 1FK704	55 dB(A) + 3 dB tolerance
1FK706	65 dB(A) + 3 dB tolerance
1FK708 to 1FK710	70 dB(A) + 3 dB tolerance

The motors are certified for a wide range of installation and operating conditions. These conditions such as rigid or vibration-isolated foundation design influence noise emission, sometimes significantly.

Preparing for use

4.1 Shipping and packaging

Checking the delivery for completeness

The drive systems are assembled on an individual basis. Upon receipt of the delivery, check immediately whether the items delivered are in accordance with the accompanying documents. Siemens will not accept any guarantee for claims relating to defects which are submitted at a later date.

- Report any apparent transport damage to the company delivering the equipment immediately.
- Report any apparent defects/missing components to the appropriate Siemens office immediately.

A second rating plate is included in the scope of delivery and can be attached close to the motor as an additional means of making the motor data available.

4.2 Transport and storage

4.2.1 Transport

Use suitable load suspension devices when transporting and installing the motor. Country-specific regulations must be observed.

If the motor is not to be commissioned immediately following delivery, it must be stored in a dry, dust-free room that is not susceptible to vibration (see the Chapter "Storage").

 WARNING
<p>Danger during lifting and transport operations!</p> <p>Improper handling, devices and equipment that are unsuitable or damaged can result in personal injury and/or material damage.</p> <p>Lifting devices, industrial trucks, and load suspension devices must comply with requirements. Pay attention to the lifting capacity of the hoisting gear. Do not attach any additional loads. To hoist the motor, use suitable cable-guidance or spreading equipment (particularly if the motor is equipped with mounted assemblies). The weight of the motor is specified on the rating plate (type plate). The motor must not be lifted or transported by means of the power connector, signal connector, or at the Sensor Module. The motor can fall down. This can result in serious physical injury or material damage to the motor up to its complete destruction.</p>

 **WARNING**

Transporting and lifting the motor using its eyebolts

In the case of larger motors, eyebolts are attached to the bearing end shields or threads to attach eyebolts.

- Eyebolts must be screwed in completely and secured by hand (approx. 8 Nm); do not overtighten.
- Do not use deformed or damaged eyebolts.
- Do not remove the laminated fiber washers
- Loads applied transversely to the plane of the eyebolt are not permitted.
- The motor must only be lifted at the eyebolts at the bearing end shields. It is not permissible to attach eyebolts to the shaft extension.

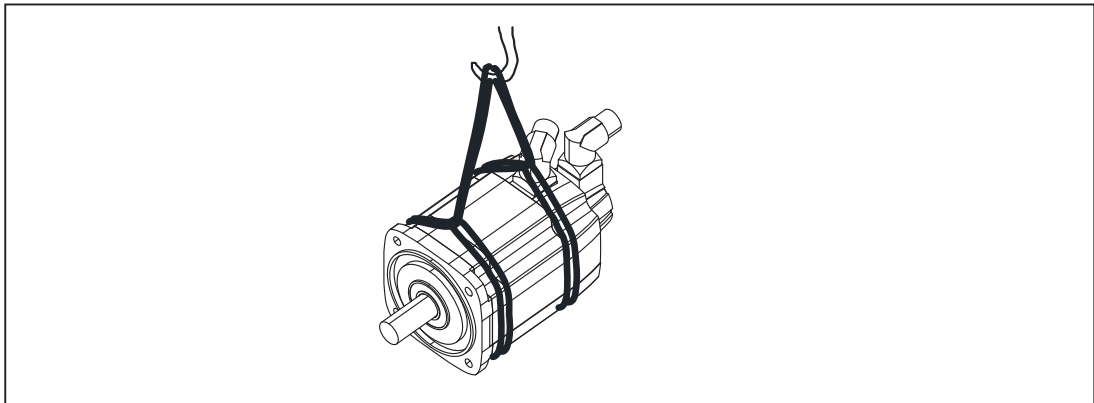

Figure 4-1 Lifting and transporting the motor using slings

4.2.2 Storage

The motors can be stored for up to two years in a dry, dust-free room that is not susceptible to vibration ($v_{\text{eff}} < 0.2$ mm/s) without the specified storage time being reduced.

CAUTION
Seizure damage to bearings
If the motors are stored incorrectly, bearing seizure damage can occur (e.g. brinelling) as a result of vibrations.

Storing indoors

- Apply a preservation agent (e.g. Tectyl) to bare, external components (e.g. shaft ends) if this has not already been carried out in the factory.
- Store the motor in an area that fulfills the following requirements:
 - Dry, dust-free, frost-free and vibration-free The relative air humidity should be less than 60% and the temperature should not drop below -15 °C (to EN 60034-1).
 - Well ventilated
 - Offers protection against extreme weather conditions
 - The air in the storage area must not contain any harmful gases.
- Protect the motor against shocks and humidity.
- Make sure that motor is covered properly.
- Avoid contact corrosion. You are advised to rotate the end of the shaft manually every three months.

Protection against humidity

If a dry storage area is not available, the following measures must be taken:

- Wrap the motor in humidity-absorbent material and then wrap it in film so that it is air tight.
- Include several bags of desiccant in the seal-tight packaging. Check the desiccant and replace as required.
- Place a humidity meter in the seal-tight packaging to indicate the level of air humidity inside it.
- Inspect the motor on a regular basis.

Installation

5.1 Installation

 CAUTION
Temperature-sensitive parts Some parts of the electrical motor enclosure can reach temperatures that exceed 100 °C. Temperature-sensitive components, e.g. cables, etc., can be damaged if they come into direct contact with the motor enclosure. When arranging temperature-sensitive components, ensure that they do not come into contact with the motor enclosure.

CAUTION
Shaft extension When installing and mounting the motor, ensure that the shaft extension is protected against impact and pressure.

Note

Observe the technical data on the labeling plates on the motor enclosure.

The following must be taken into account when installing motors

- Observe the data on the rating plate, as well as the warning and information plates on the motor.
- Observe permissible radial and axial forces (refer to the configuration manual). Axial forces are not permitted for motors equipped with an integrated brake.
- Check that the motors comply with the conditions (e.g. temperature, installation altitude) at the installation location.
- Their use is prohibited in hazardous zones and areas.
- Ensure that the shaft extension is completely free of any anti-corrosion protection (use a commercially available solvent).
- For natural-cooled motors, it must be ensured that thermal losses can be properly dissipated (see the chapter titled "Cooling").
- If the motor is installed vertically with the shaft extension facing up, ensure that no liquid can enter the upper bearing.

- Eyebolts that have been screwed in must either be tightened or removed after installation.
- Ensure that the flange joint sits evenly; avoid applying an excessive force to fixing screws when tightening. Use hexagon socket head cap screws with a property class of 8.8. Observe the tightening torques for the fixing screws of the motor flange.

Table 5- 1 Tightening torques

Motor	Screw DIN 7984	Washer ISO 7092 [mm]	Tightening torque for screws (not for electrical connections)
1FK701□	M4	4 (d2 = 8)	2.2 Nm
1FK702□	M5	5 (d2 = 9)	4 Nm
1FK703□	M6	6 (d2 = 11)	8 Nm
1FK704□	M6	6 (d2 = 11)	8 Nm
1FK706□	M8	8 (d2 = 15)	20 Nm
1FK708□	M10	10 (d2 = 18)	35 Nm
1FK710□	M12	12 (d2 = 20)	60 Nm

5.2 Attaching transmission elements

NOTICE

Do not subject the motor's shaft and bearings to impact. Do not exceed the permissible axial and radial forces at the shaft extension, as defined in the configuration specifications. Axial forces are not permitted for motors with an integrated holding brake.

Suitable equipment (see figure) must be used when fitting and removing transmission elements (e.g. coupling, gear wheel, belt pulley).

- Use a threaded hole in the shaft extension.
- If necessary, heat up the transmission elements.
- When removing transmission elements, use an intermediate disk or washer to protect the centering in the shaft extension.
- If necessary, fully balance the motor with transmission elements in accordance with ISO 1940.

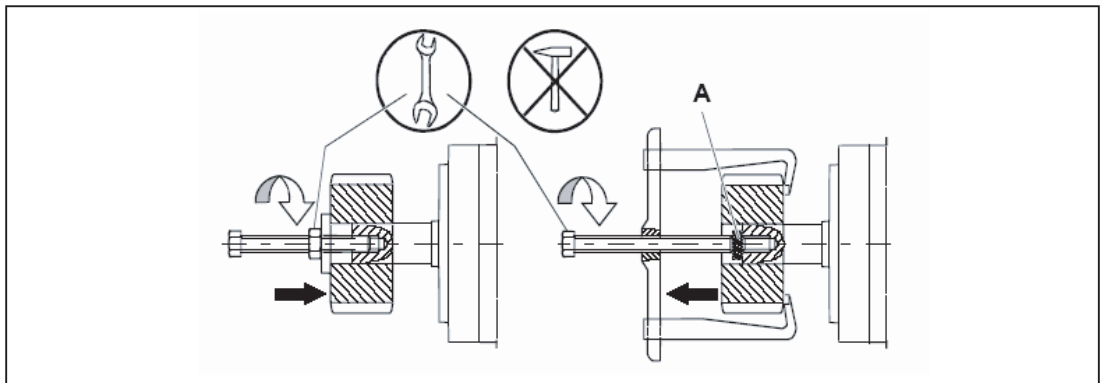

Figure 5-1 Fitting/removing transmission elements; A = intermediate disk/washer (to protect the centering in the shaft extension)

5.3 Vibration response

Motors with a keyway are balanced with a half fitted key by the manufacturer. The vibration response of the system at the installation location is influenced by transmission elements, any mounted parts, the alignment, the installation, and external vibrations. As a result, the motor's vibration values may change.

The motors conform to vibration severity grade A in accordance with EN 60034-14 (IEC 60034-14).

The specified values refer only to the motor. These values can be increased at the motor due to the overall vibration response of the complete system after the drive has been mounted.

The vibration severity level is maintained up to the rated speed (n_N).

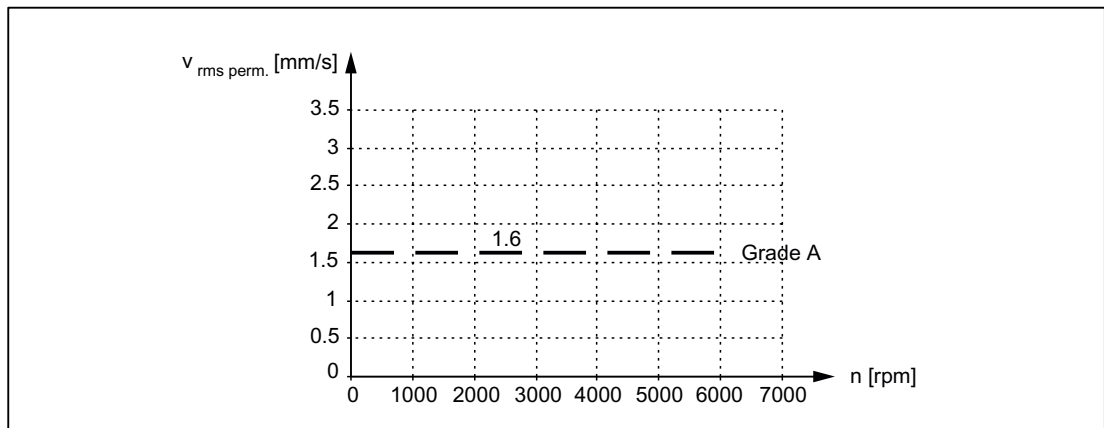



Figure 5-2 Vibration severity levels

Connecting

6.1 Electrical connection

6.1.1 Safety instructions

 DANGER
Risk of electric shock When the rotor is turning, a voltage of approx. 300 V is available at the motor terminals. All work performed on electrical components must be carried out when the motor is at a standstill. This also applies to auxiliary circuits. Converters and connectors must only be installed by appropriately trained personnel. The connectors may only be installed or removed when the equipment is in a no-voltage condition. Regulations regarding work carried out in electrical installations must be observed.
CAUTION
Electrostatic sensitive devices The motor contains electrostatic sensitive devices. Touching signal connections with electrostatically charged hands or tools can result in malfunctions. Note the ESD protection measures.

Safety regulations for work performed in electrical installations to EN 50110-1 (DIN VDE 0105-100):

- Disconnect the system.
- Protect against reconnection.
- Make sure that the equipment is de-energized and in a no-voltage condition.
- Ground and short-circuit.
- Cover or enclose adjacent components that are still live.

6.1.2 Circuit diagram

The circuit diagram contains information about wiring and connecting the motor winding.

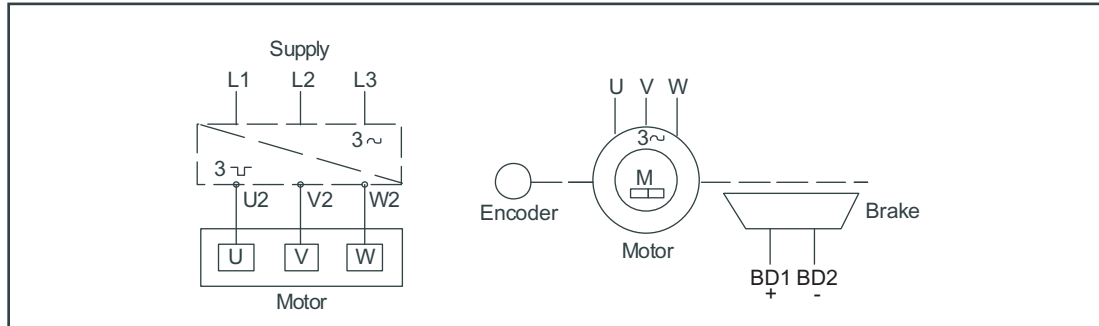

Figure 6-1 Circuit diagram

6.1.3 Motor connection

! DANGER

Warning regarding motor damage!

The motor will be destroyed if it is directly connected to the three-phase line supply.

Only operate the motors with the appropriately engineered converters! Ensure the correct phase sequence is used!

Encoder systems and temperature sensors are electrostatic sensitive devices (ESD). Do not touch the connections with either hands or tools that could be electrostatically charged!

- We recommend that SIEMENS prefabricated cables are used (not included in the scope of delivery). These cables reduce installation costs and increase operational reliability (see the Configuration Manual).
- The manufacturer of the plant/machine is responsible for ensuring that the installation is performed correctly.
- Observe the data on the rating plate and the circuit diagrams.
- Adapt the connecting cables in accordance with the type of use and the voltages and currents that arise.
- When fed from a converter, high-frequency current and voltage oscillations in the motor feeder cables can cause electromagnetic interference. Use shielded power cables and signal lines. Carefully observe the EMC information of the converter manufacturer.
- Make sure that the inside of the connector is clean and free of cable cuttings and moisture.
- Avoid protruding cable ends.
- Check seals and sealing surfaces of the connectors to ensure that the degree of protection is maintained.

- Take measures to ensure that connecting cables cannot rotate, are not subject to strain and pushing force and also provide anti-kink protection. It is not permissible to subject the connector to continuous force.
- The coding groove of the plug-in connection must be inserted so that it is aligned in the socket connector and the screw cap must be tightened by hand as far as it will go.

 **CAUTION****High thermal stress**

For high thermal stresses, e.g. overload when the motor is stationary, the protective function with integrated temperature sensor may not be adequate. In these cases, apply additional protective measures, e.g. i^2t monitoring.

Current-carrying capacity for power and signal cables

The current carrying capacity of PVC/PUR-insulated copper cables is specified for routing types B1, B2, C and E under continuous operating conditions in the table with reference to an ambient air temperature of 40 °C. For other ambient temperatures, the values must be corrected by the factors from the "Derating factors" table.

Table 6- 1 Cable cross section and current-carrying capacity

Cross section [mm ²]	Current-carrying capacity rms; AC 50/60 Hz or DC for routing type			
	B1 [A]	B2 [A]	C [A]	E [A]
Electronics (according to EN 60204-1)				
0.20	-	4.3	4.4	4.4
0.50	-	7.5	7.5	7.8
0.75	-	9	9.5	10
Power (according to EN 60204-1)				
0.75	8.6	8.5	9.8	10.4
1.00	10.3	10.1	11.7	12.4
1.50	13.5	13.1	15.2	16.1
2.50	18.3	17.4	21	22
4	24	23	28	30
6	31	30	36	37
10	44	40	50	52
16	59	54	66	70
25	77	70	84	88
35	96	86	104	110
50	117	103	125	133
70	149	130	160	171
95	180	165	194	207
120	208	179	225	240
Power (according to IEC 60364-5-52)				
150	239 ¹⁾	206 ¹⁾	259 ¹⁾	276 ¹⁾
185	274 ¹⁾	235 ¹⁾	296 ¹⁾	315 ¹⁾
> 185	Values must be taken from the standard			

1) Extrapolated values

Table 6- 2 Derating factors for power and signal cables

Ambient air temperature [°C]	Derating factor according to EN 60204-1, Table D1
30	1.15
35	1.08
40	1.00
45	0.91
50	0.82
55	0.71
60	0.58

Connector types

Power connections U, V, W

Brake connection BD1+, BD2- (only when ordered)

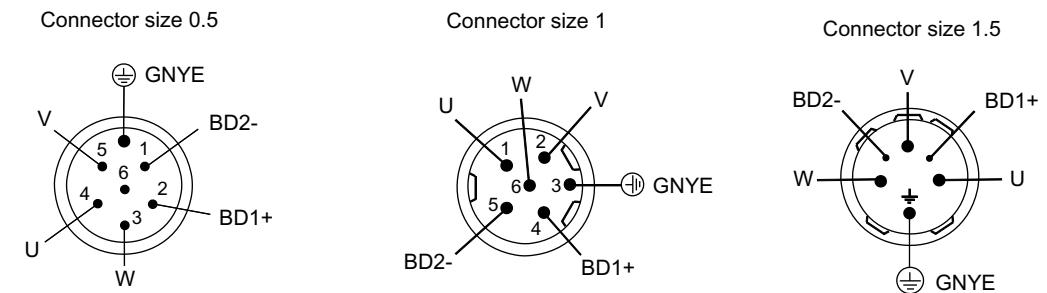

Figure 6-2 Power connector

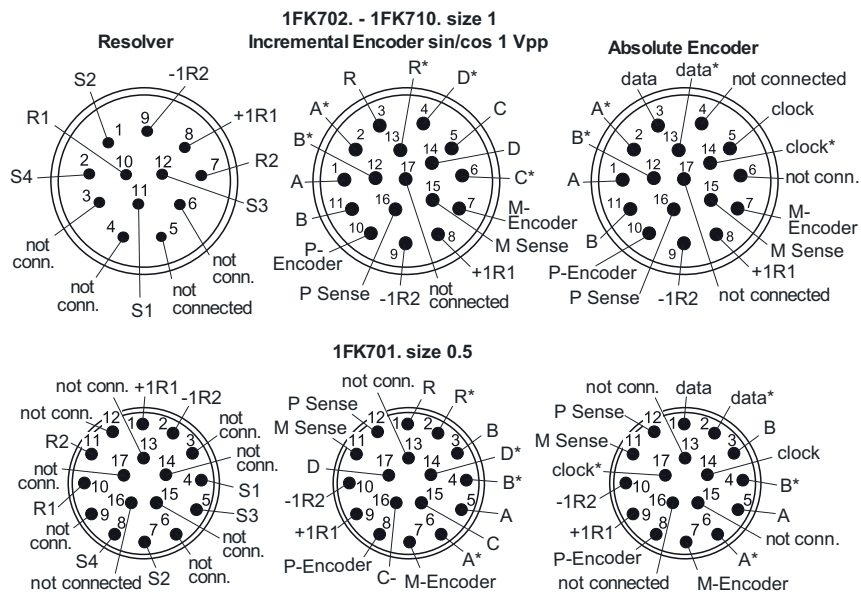

Figure 6-3 Pin assignment of the signal connectors (motors without a DRIVE-CLiQ interface)

6.1.4 Rotating the connector for 1FK7xxx5 and 1FK7xxx-7

Power connectors and signal connectors can be rotated to a limited extent. A suitable socket connector can be used to rotate the angle plug. Make sure that the socket connector is completely secure to avoid damaging the pin contacts. For encoders with integrated Sensor Modules (DQI) the cable outlet towards the top is fixed and cannot be changed.

NOTICE
<p>Rotating the connectors</p> <ul style="list-style-type: none"> • It is not permissible that the specified rotation range is exceeded. • In order to guarantee the degree of protection, max. 10 revolutions are permissible. • Connectors should be rotated using the matching mating connector located on the connector thread. Only rotate Sensor Modules by hand. The use of pipe wrenches, hammers, or similar is not permitted.

Table 6-3 Direction of rotation and max. torque when rotating

Connectors	Rotation range	Max. torque when rotating
Power connector, size 0.5	270°	8 Nm
Power connector, size 1	270°	12 Nm
Power connector, size 1.5	270°	20 Nm
Signal connector (without DRIVE-CLiQ)	230° for SH 20 180° for SH 28 ... 80 90° for SH 100	8 Nm 12 Nm 12 Nm
Signal connector (with DRIVE-CLiQ)	270°	8 Nm

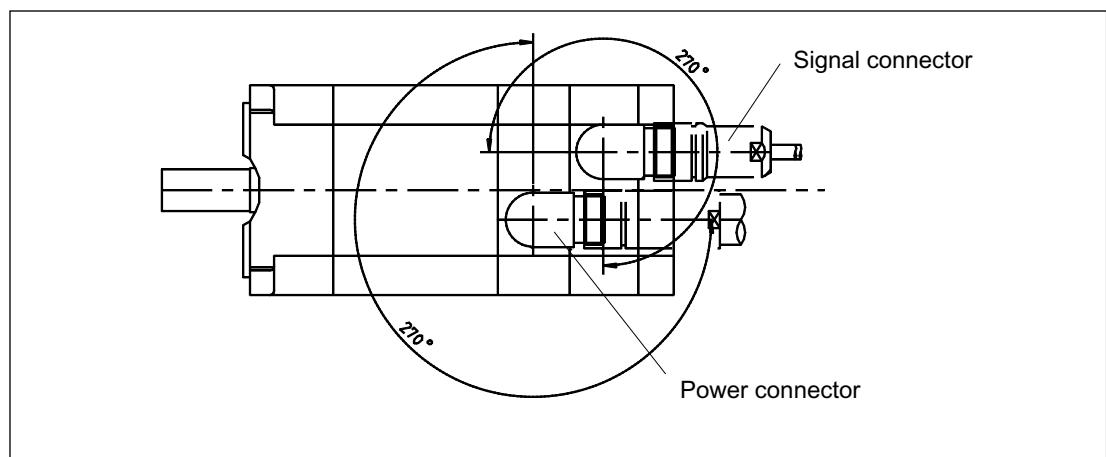

Figure 6-4 Ability to rotate the connector using 1FK7□□□-5 motors as an example

6.1.5 Rotating the connector for 1FK7xxx-2, 1FK7xxx-3, 1FK7xxx-4

Power connectors and signal connectors can be rotated to a limited extent. A suitable socket connector can be used to rotate the angle plug. Make sure that the socket connector is completely secure to avoid damaging the pin contacts. For encoders with integrated Sensor Modules (DQI) the cable outlet towards the top is fixed and cannot be changed.

NOTICE

Rotating the connectors

- It is not permissible that the specified rotation range is exceeded.
- In order to guarantee the degree of protection, max. 10 revolutions are permissible.
- Connectors should be rotated using the matching mating connector located on the connector thread. Only rotate Sensor Modules by hand. The use of pipe wrenches, hammers, or similar is not permitted.

Ability to rotate the power connector for motors with DRIVE-CLiQ interface without Sensor Modules 1FK7□□□-□□□□□-□X□□; X = B, C, Q, R

Table 6- 4 Rotation range of the power connector

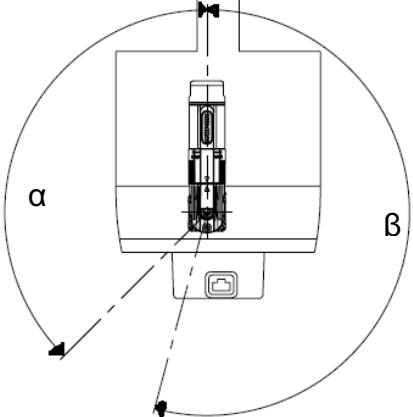
Motor	Angle α	Angle β	Connector size	Drawing
1FK703	122°	208°	1	 <p>The drawing shows a cross-section of a power connector assembly. A central shaft with a pin is shown. Two dashed lines with arrows indicate the rotation range of the connector. The angle between the vertical reference line and the first dashed line is labeled α. The angle between the vertical reference line and the second dashed line is labeled β.</p>
1FK704 1FK706 1FK708 1FK710	135°	195°	1	
1FK708 1FK710	195°	140°	1.5	

Ability to rotate the connectors for motors without a DRIVE-CLiQ interface and for motors with DRIVE-CLiQ interface via Sensor Modules
1FK7□□□-□□□□□-□X□□; X = A, E, H, D, F, L

Table 6- 5 Rotation range of the power connector

Motor	Angle α	Angle β	Connector size	Drawing
1FK703	122°	158°	1	
1FK704 1FK706 1FK708	135°	140°	1	
1FK710	135°	195°	1	
1FK708 1FK710	195°	140°	1.5	

Table 6- 6 Rotation range of the signal connector

Motor	with DRIVE-CLiQ via Sensor Module		connector without DRIVE-CLiQ		Drawing
	Angle α'	Angle β'	Angle α'	Angle β'	
1FK703	160°	130°	160°	135°	See Table, "Power connectors"
1FK704	145°	140°	145°	130°	
1FK706	140°	145°	150°	135°	
1FK708 1FK710	105°	100°	105°	105°	

Table 6- 7 Max. torque when rotating

Connectors	Max. torque when rotating
Power connector, size 1	12 Nm
Power connector, size 1.5	20 Nm
Signal connector (without DRIVE-CLiQ)	12 Nm
Signal connector (with DRIVE-CLiQ)	8 Nm

6.1.6 Motors with DRIVE-CLiQ interface

Motors designed for SINAMICS drive systems have an integrated encoder and temperature evaluation system as well as an electronic rating plate. The connection to the converter system uses a 10-pole RJ45plus socket. This is known as a DRIVE-CLiQ interface. The pin assignment is independent of the motor-internal encoder.

NOTICE

The Sensor Module is in direct contact with electrostatically-sensitive components. It is not permissible to touch the connections with either hands or tools that could be electrostatically charged.

The signal connection between the motor and Motor Module is established using a DRIVE-CLiQ cable (MOTION-CONNECT). The DRIVE-CLiQ cable connector must be inserted far enough so that the catch springs engage.

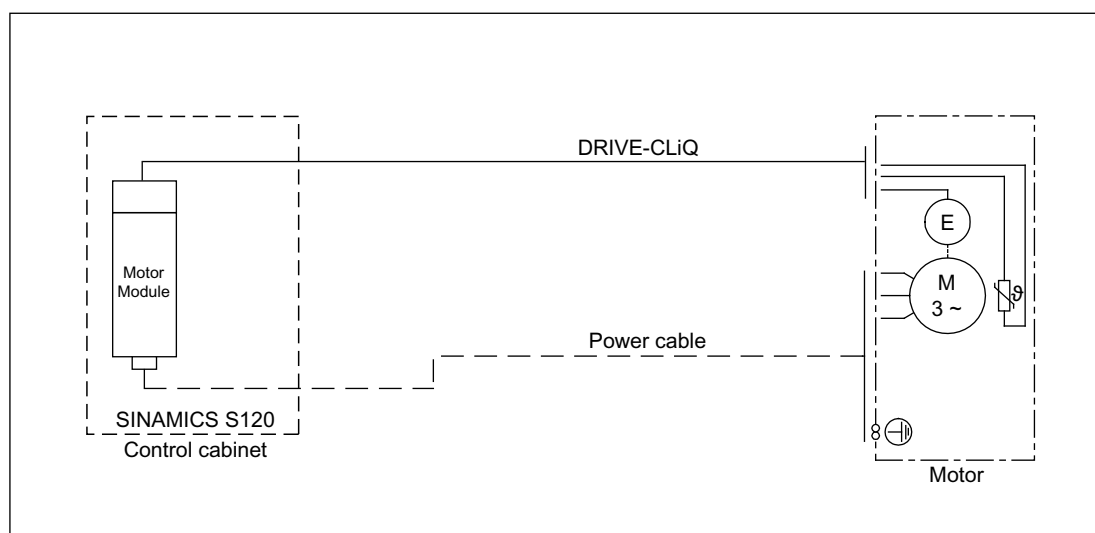

Figure 6-5 Encoder interface with DRIVE-CLiQ

6.1.7 Motors without DRIVE-CLiQ interface

If a motor is not equipped with a DRIVE-CLiQ interface, the speed encoder and temperature sensor are connected via a signal connector.

Motors without DRIVE-CLiQ require a Sensor Module Cabinet (SMC) for operation with a SINAMICS S120 drive system. The motor is connected to the SMC via a signal line. The SMC is connected to the motor via a DRIVE-CLiQ cable (MOTION-CONNECT).

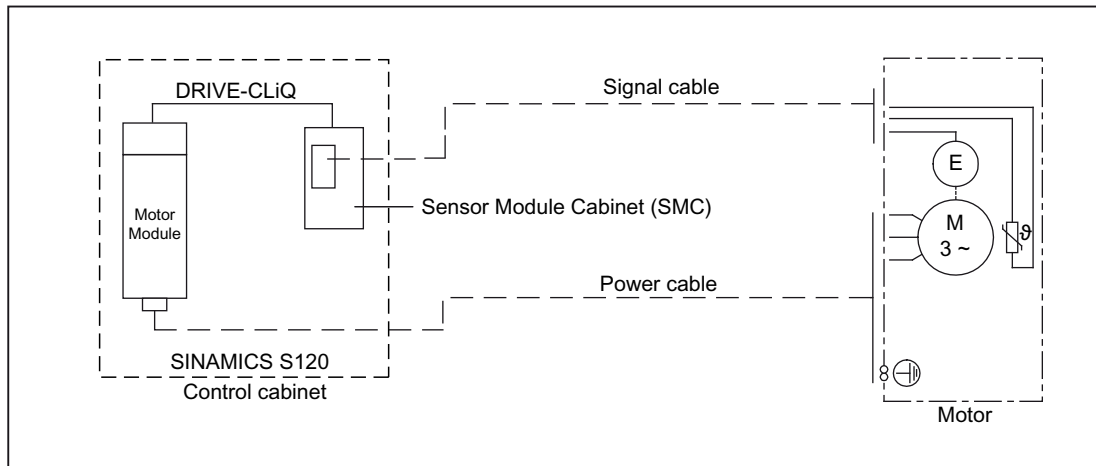

Figure 6-6 Encoder connection without DRIVE-CLiQ

6.1.8 Connecting to a converter

Selecting and connecting the cable

To connect the motor to a converter, use MOTION-CONNECT cables or shielded connecting cables. The protective braided shield of the cable must be made up of as many strands as possible and have good electrical conductivity. Braided shields made of copper or aluminum are very suitable.

The shield must be connected at both ends to the motor and the converter; unshielded cable ends must be kept as short as possible.

In order to ensure good discharge of high-frequency currents, provide a 360° contact through a large surface area at the converter.

7.1 Measures prior to commissioning

Before commissioning the system, check that it is properly installed and connected. The drive system must be commissioned as described in the operating instructions for the converter/inverter.



 DANGER

Risk of electric shock

When commissioning/operating electric motors, parts of the motor are always at a dangerous voltage. If this motor is not correctly handled/operated, this can result in death or severe personal injury as well as significant material damage. All of the warning information on the product must be carefully observed!

 WARNING

Danger from rotating rotor.

Provide the appropriate guards and covers for transmission elements.
--

Note

This list below does not claim to be complete. It may be necessary to perform additional checks and tests in accordance with the specific situation at the plant or system.

Mechanical connection

Make sure that:

- Touch protection measures are in place for moving and live parts.
- The fitted keys in the shaft extension (if available) must be firmly secured to prevent them from being flung out.
- The motor has been correctly installed and aligned.
- The rotor can turn without coming into contact with other parts and components.
- The operating conditions correspond to the data specified on the rating plate.

7.1 Measures prior to commissioning

- All fixing screws, connecting elements, and electrical connections are tight and have been attached properly.
- The transmission elements have the proper setting conditions according to type, for example:
 - Couplings are aligned and balanced.
 - The belt tension is properly adjusted if a belt drive is used.
 - Gear tooth flank play and gear tooth tip play as well as radial play are properly adjusted if a gear drive is used.

Electrical connection

Make sure that:

- The grounding and equipotential bonding connections have been established correctly.
- The brake is operating perfectly.
- The specified speed limit n_{\max} is not exceeded when operated from a converter.

Monitoring equipment

Make sure that:

- Appropriately configured control and speed monitoring functions are being used to ensure that the motor cannot exceed the permissible speeds specified on the rating plate.
- Any supplementary motor monitoring devices and equipment have been correctly connected and are fully functional.

Brake (optional)

Make sure that:

- Applying the operating voltage causes the brake to open.
- The brake functions (opens, closes) correctly.

7.2 Switching on

Before you switch on the motor, ensure that the parameters of the frequency converter have been assigned correctly.

Use the appropriate commissioning tools (e.g. "Drive ES" or "STARTER").

CAUTION

Uneven running or abnormal noises

The motor can be damaged by improper handling during transport, storage or installation. If a damaged motor is operated, this can damage the winding or bearings and could even destroy the system.

If the motor is not running smoothly or is making abnormal noises, shut the motor down and try to determine the cause of the fault as it runs down.

CAUTION

Observe the maximum speed

The maximum speed n_{\max} is the highest permissible operating speed. The maximum speed is specified on the rating plate.

Exceeding speed n_{\max} can result in material damage or could even completely destroy the motor. An appropriately configured control or an active speed monitoring function in the drive should be used to ensure that the motor cannot exceed the permissible speeds.

8.1 Safety guidelines in operation

 WARNING
Do not remove covers when the motor is running Rotating or live parts are dangerous. Death, serious injury, or material damage can result if the required covers are removed. All covers that prevent personnel from coming into contact with active or rotating parts, ensure compliance with the required degree of protection, or ensure proper air guidance and, in turn, effective cooling must not be opened/removed during operation.

 WARNING
Faults in operation Deviations from normal operation (e.g. increased power consumption, temperature, or vibration levels, unusual noises or smells, tripping of monitoring equipment, etc.) indicate that the machine is not functioning properly. This can cause faults that can result in eventual or immediate death, severe personal injury, or material damage. Immediately inform the maintenance personnel. If in doubt, shut down the motor immediately, taking into account the plant-specific safety regulations.

 CAUTION
Danger of burns The temperature of certain parts of the motor can exceed 100 °C. Physical contact can cause serious burns. Check the temperature of the parts before touching them and take appropriate protective measures if necessary.

8.2 Faults

Note

Damage to the machine caused by faults

Correct the cause of the fault as specified in the remedial measures section. Repair any damage to the machine/motor.

Note

When operating the motor with a converter, refer also to the operating instructions of the frequency converter if electrical faults occur.

If there are deviations from normal operation or if faults occur, initially proceed according to the following list. In this regard, observe the relevant chapters in the documentation associated with the components of the complete drive system.

Even in test operation, never disable protective functions or devices.

Table 8- 1 Possible faults

Fault	Cause of fault (see key table)																		
	A	B	C	D	E	F	G	H	I	J	K	L	M	N	O	P	Q	R	
Motor does not start	A	B																	
Motor starts slowly	A		C			F													
Humming sound when starting			C			F													
Humming sound in operation	A		C			F													
High temperature rise under no-load operation				D			G	H	I										
High temperature rise under load	A		C				G	H	I										
High temperature rise of individual winding sections						F													
Uneven running										J	K								
Grinding sound, running noise												L							
Radial vibrations													M	N	O	P		R	
Axial vibrations															O		Q	R	

Table 8- 2 Key to causes of faults and remedial measures

No.	Cause of fault	Remedial measures
A	Overload	Reduce load
B	Interruption of a phase in the supply cable/motor winding	Check the frequency converter and supply cables/measure the winding resistances and insulation resistances, repair after consultation with manufacturer
C	Interrupted phase in the feeder cable after switching on	Check the frequency converter and supply cables/check the winding resistances
D	Converter output voltage too high, frequency too low	Check the settings on the frequency converter, perform automatic motor identification
F	Winding short circuit or phase short circuit in stator winding	Measure the winding resistances and insulation resistances, repair after consultation with manufacturer
G	Cooling water not connected / switched off	Check cooling water connection/switch on cooling water
	Water connection / pipes defective	Locate leaks and seal as necessary, or consult the manufacturer
H	Cooling water flow rate too low	Increase cooling water flow rate
	Inlet temperature too high	Set correct inlet temperature
I	Heat dissipation impeded by deposits	Clean the surface of the drives and ensure that the cooling air can flow in and out unimpeded
	Cooling air inlet/outlet is blocked by foreign bodies	Remove the block and ensure that the cooling air can flow in and out unimpeded
	Fan motor does not start	Check the fan motor to ensure that it is functioning correctly
J	Insufficient shielding for motor and/or encoder cable	Check the shielding and grounding
K	Excessive drive controller gain	Adjust the controller
L	Rotating parts are grinding	Determine cause and adjust parts
	Foreign bodies inside the motor	Send to manufacturer for repair
	Bearing damage	Send to manufacturer for repair
M	Rotor not balanced	Decouple rotor and rebalance
N	Rotor out of true, shaft bent	Consult the manufacturer
O	Poor alignment	Align motor set, check coupling
P	Coupled machine not balanced	Re-balance coupled machine
Q	Shocks from coupled machine	Check coupled machine
R	Fault originating from the gear unit	Adjust/repair gear unit

If the fault still cannot be resolved after applying the measures specified above, please contact the manufacturer or the Siemens Service Center.

8.3 Non-operational periods

Measures for motors that are ready for operation but which are presently not being used

- If the motor is out of service for extended periods of time, operate it at regular intervals (roughly once a month) or at least spin the rotor.
- Refer to the section "Switching on" before recommissioning the motor.

NOTICE
Damage due to improper storage
The motor can be damaged if it is not stored properly.
If the motor is out of service for extended periods of time, apply suitable anti-corrosion, preservation and ensure that it is kept dry.
When recommissioning the motor after it has been out of service for a longer period of time, carry out the measures recommended in the Chapter "Commissioning".

Maintenance

9.1 Inspection and maintenance

9.1.1 Safety instructions

If you are unclear about anything, consult the manufacturer, specifying the motor type and serial number, or arrange for the maintenance work to be carried out by one of the Siemens Service Centers.

DANGER

Risk of electric shock from touching live parts

Live electrical parts are dangerous. Touching these parts will result in an electric shock, which in turn causes death or serious injury.

Before starting work on the machines, make sure that the plant or system has been disconnected in a manner that is compliant with the appropriate specifications and regulations. In addition to the main currents, make sure that supplementary and auxiliary circuits, particularly heating devices, are also disconnected.

WARNING

Danger of burns

Some parts of the frame of electrical motors can reach temperatures in excess of 100°C.

Touching components when the machine is in operation can cause severe burns.

Do not touch frame parts while the machine is in operation or immediately after machine operation. Allow frame parts to cool off before starting any work.

Safety regulations

Before starting maintenance work, always observe the five safety rules.

1. Disconnect the system.
2. Protect against reconnection.
3. Make sure that the equipment is de-energized and in a no-voltage condition.
4. Ground and short-circuit.
5. Cover or enclose adjacent components that are still live.

9.1.2 Maintenance intervals

General

Careful and regular maintenance, inspections, and overhauls are essential for detecting and eliminating faults in good time before they can cause any damage.

NOTICE
Inspection if there are faults or unusual conditions
Unusual conditions or faults that represent electrical or mechanical overstressing of the three-phase motor, such as overload, short circuit, etc. can cause consequential damage to the machine.
If there are faults or unusual conditions such as overload or short circuit etc. immediately perform the inspections.

Measures, inspection/maintenance intervals

Operating conditions and characteristics can vary widely. For this reason, only general maintenance intervals can be specified here.

- Maintenance intervals should, therefore, be scheduled to suit the local conditions (pollution/dirt, switching frequency, load, etc.).
- Perform the following measures after the operating time or the interval specified in the following table elapses.

Table 9- 1 Measures after operating times or intervals

Measures	Operating times and intervals
Replace the bearings	Note the recommended bearing replacement intervals (see "Bearing replacement intervals")
Replace the radial shaft sealing rings	Approximately every 10,000 operating hours with oil lubrication

9.1.3 Bearing change interval

The bearings are subject to wear and must be replaced after a defined number of operating hours. For average load levels, the bearings must be replaced after approx. 25 000 h.

The lifetime can be extended if the motor is operated under favorable conditions (e.g. low or medium speeds, low radial forces (cantilever forces), vibration load).

NOTICE
Harsh operating conditions
If the motor is subject to harsh operating conditions (e.g. continuous operation at n_{\max} , high vibration/shock loads, frequent reversing duty etc.), the bearing replacement intervals t_{LW} can decrease by up to 50%.

9.2 Repair

9.2.1 Safety instructions

Qualified personnel

This machine must be commissioned and operated by qualified personnel only. For the purpose of the safety information in this documentation, a "qualified person" is someone who is authorized to energize, ground, and tag equipment, systems, and circuits in accordance with established safety procedures.

Safety notes

 WARNING
Rotating or live parts
Rotating or live parts are dangerous. Death, serious injury, or material damage can result if the required covers are removed or if the device is not operated properly.
Before starting work on the motor and, in particular, before opening the covers of live parts, make sure that the motor or system is properly disconnected and is in a no voltage condition.

 WARNING
Transportation in accordance with proper procedures
Only transport the motor in accordance with the transport guidelines. Death, serious injury, or material damage can result if the motor is not transported properly.
Whenever you have to transport the motor, follow the instructions provided in the section "Transport and storage".

9.2.2 Removing/Installing the encoder

For 1FK7□□-2, 1FK7□□-3 and 1FK7□□-4 motors, the encoder module (with the exception of resolver) can be simply replaced without re-adjustment.

CAUTION

Electrostatic sensitive devices

Electronic modules contain components that can be destroyed by electrostatic discharge. These modules can be easily destroyed by improper handling.

To protect your equipment against damage, follow the instructions provided in the chapter "ESD Guidelines".

Removal

1. Disconnect the motor
2. Remove the four fastening screws of the encoder.
3. Remove the encoder

Installation

1. Insert the coupling element onto the encoder shaft.
2. Align the coupling element with the coupling half on the motor.
3. Attach the encoder at this position on the motor shaft.
4. Secure the encoder with four screws (tightening torque: 2 to 3 Nm).

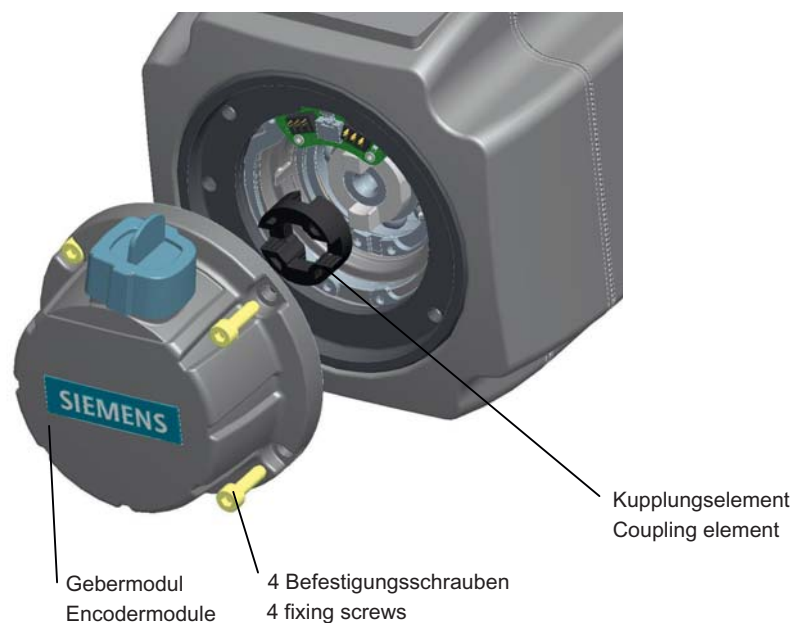

Figure 9-1 Removing/Installing the encoder

Note

Coupling element

When replacing the encoder, the coupling element must also be replaced.

Motors with DRIVE-CLiQ

NOTICE
Motor data (electronic rating plate) You must ensure that the new encoder contains the correct motor data. If it does not, the motor may move in an uncontrolled fashion, leading to considerable material damage.

You can purchase a preprogrammed encoder module from the Siemens Service Center by quoting the relevant order number and serial number. If your encoder module is not preprogrammed, it must be programmed with the correct motor data prior to use.

Decommissioning and disposal

10.1 Decommissioning

10.1.1 Preparing for removal

Disassembly of the machine must be carried out and/or supervised by qualified personnel with appropriate expert knowledge.

1. Contact a certified waste disposal organization in your vicinity. Clarify what is expected in terms of the quality when dismantling the machine and provision of the components.
2. Follow the five safety rules.
3. Disconnect all electrical connections.
4. Remove all liquids such as oil, water, ...
5. Remove all cables.
6. Remove the machine fixing elements
7. Transport the machine to a suitable location for disassembly.

Also observe the notes provided in Chapter "Maintenance".

10.1.2 Dismantling the motor

Dismantle the machine using the general procedures commonly used in mechanical engineering.

 WARNING
Machine parts can fall The machine is made up of heavy parts. These parts can fall during dismantling. This can result in death, serious injury, or material damage. Secure the machine parts being dismantled to prevent them falling.

The motors must be disposed of in accordance with domestic and local regulations as part of the standard recycling process or they can be returned to the manufacturer.

10.2 Disposal

Protecting the environment and preserving its resources are corporate goals of the highest priority for us. Our worldwide environmental management system to ISO 14001 ensures compliance with legislation and sets high standards in this regard. Environmentally friendly design, technical safety and health protection are always firm goals even at the product development stage.

Recommendations for the environmentally friendly disposal of the machine and its components are given in the following section. Be sure to comply with local disposal regulations.

Components

Sort the components for recycling according to whether they are:

- Electronics waste, e.g., sensor electronics
- Iron to be recycled
- Aluminum
- Non-ferrous metal, e.g., motor windings
- Insulating materials

Process materials and chemicals

Sort the process materials and chemicals for recycling according to whether they are:

- Oil
Dispose of the spent oil as special waste in accordance with the spent oil ordinance.
- Grease
- Solvents
- Cleaner solvent
- Paint residues

Do not mix solvents, cleaner solvents and paint residues.

Appendix

A.1 Order number Configuration Manual

Table A- 1 Order numbers (MLFB) of the Configuration Manuals

Title Configuration Manual	German	English
1FK7 Synchronous Motors for SINAMICS S120	6SN1197-0AD16-0AP2	6SN1197-0AD16-0BP2
1FK7 Synchronous Motors for SIMODRIVE and SIMOVERT MASTERDRIVES	6SN1197-0AD06-0BP1	6SN1197-0AD06-0BP1

A.2 Declaration of conformity



EG-Konformitätserklärung EC Declaration of Conformity No. 664.20022.21

Hersteller: **Siemens Aktiengesellschaft**
Manufacturer: Industrie Sector
DT MC EWN

Anschrift: Industriestraße 1
Address: 97615 Bad Neustadt a. d. Saale
Germany

Produktbezeichnung: **Drehstrom – Synchronmotor, Servoantrieb Typ 1FK7...**
Description of the product: *Three-phase synchronous servo-motor, type 1FK7...*

Die bezeichneten Produkte stimmen in der von uns in Verkehr gebrachten Ausführung mit den Vorschriften folgender Europäischer Richtlinie überein:
The products described above in the form as delivered are in conformity with the provisions of the following European Directive:

2006/95/EG Richtlinie des Europäischen Parlaments und de Rates vom 12.Dezember 2006 zur Angleichung der Rechtsvorschriften der Mitgliedstaaten betreffend elektrische Betriebsmittel zur Verwendung innerhalb bestimmter Spannungsgrenzen.
Directive of the European Parliament and the Council of 12. December 2006 on the approximation of the laws of the Member States related to electrical equipment designed for use within certain voltage limits.

Die Konformität mit der Richtlinie wird nachgewiesen durch die Einhaltung folgender Normen:
Conformity to the Directive is assured through the application of the following Standards:

EN 60034-1*): 2004 EN 60204-1 : 2006
*) mit allen relevanten Teilen / *with all relevant parts*

Die Sicherheitshinweise und Betriebsanleitungen sind zu beachten.
The safety and manual documentation have to be considered in detail.

Erste CE - Kennzeichnung: 2002 / *first CE - marking: 2002*

Die bezeichneten Produkte sind zum Einbau in andere Maschinen bestimmt. Die Inbetriebnahme ist solange untersagt, bis die Konformität des Endproduktes mit der Richtlinie 2006/42/EG festgestellt ist. Alle Sicherheitshinweise der zugehörigen Produktdokumentation sind zu beachten sowie dem Endanwender zur Kenntnis zu geben.
Diese Erklärung stellt keine Beschaffenheits- und Haltbarkeitsgarantie gemäß § 443 BGB dar.

The products supplied are intended exclusively for installation in a machine. Commissioning is prohibited until it has been established that the end product conforms with the Directive 2006/42/EU. All safety instructions in the associated product documentation must be observed and given to the end user for his/her information. This declaration contains no condition and durability guarantee to § 443 BGB (German Civilian Code).

Bad Neustadt, den 10.02.2010

Siemens Aktiengesellschaft

Frank Michael,
Head of the Electric Motor Factory, Bad Neustadt

Dr. Jan Dainat,
Head von Engineering Department (KT)

Diese Erklärung bescheinigt die Übereinstimmung mit der genannten Richtlinie, ist jedoch keine Zusicherung von Eigenschaften.
This declaration certifies the conformity to the specified Directive, but contains no assurance of properties.

Ersatz für / *Substitute for* 664.20022.21 Stand / *Status:* 02/2002

Ausgabestand / Status: 02/2010
Erstausgabe / first document: 02/2002

Siemens Aktiengesellschaft: Chairman of the Supervisory Board: Gerhard Cromme; Managing Board: Peter Loescher, Chairman, President and Chief Executive Officer; Wolfgang Dehen, Heinrich Hiesinger, Joe Kaeser, Barbara Kux, Hermann Requardt, Siegfried Russwurm, Peter Y. Solmsen; Registered offices: Berlin and Munich, Germany; Commercial registries: Berlin Charlottenburg, HRB 12300, Munich, HRB 6684; WEEE-Reg.-No. DE 23691322

Index

A

Ambient conditions, 16

B

Bearing change interval, 47

C

Circuit diagram, 28

Commissioning, 37

Cooling, 16

D

Declaration of conformity, 54

Degree of protection, 15

Disposal, 52

DRIVE-CLiQ interface, 35

E

Electrical connection, 27

I

Inspection and maintenance, 45

Installation, 23

N

Natural cooling, 16

Noise emission, 17

R

Rating plate, 14

Replacing an encoder, 49

S

Safety instructions, 7

Shipping, 19

Sound pressure level, 17

Storage, 21

T

Technical features, 12

Tightening torques, 24

Types of construction, 15

U

UL regulations, 15

V

Vibration response, 26

Siemens AG
Industry Sector
Drive Technologies
Motion Control Systems
P.O. Box 3180
91050 ERLANGEN
GERMANY

Subject to change without prior notice
© Siemens AG 2011

www.siemens.com/motioncontrol