

SIEMENS

SIMATIC TI525/TI535

Hardware and Installation

User Manual

Order Number: PPX:505-8103-3
Manual Assembly Number: 2586546-0052
Third Edition

**Copyright 1993 by Siemens Industrial Automation, Inc.
All Rights Reserved — Printed in USA**

Reproduction, transmission or use of this document or contents is not permitted without express consent of Siemens Industrial Automation, Inc. All rights, including rights created by patent grant or registration of a utility model or design, are reserved.

Since Siemens Industrial Automation, Inc. does not possess full access to data concerning all of the uses and applications of customer's products, we do not assume responsibility either for customer product design or for any infringements of patents or rights of others which may result from our assistance.

Technical data is subject to change.

We check the contents of every manual for accuracy at the time it is approved for printing; however, there may be undetected errors. Any errors found will be corrected in subsequent editions. Any suggestions for improvement are welcomed.

MANUAL PUBLICATION HISTORY

SIMATIC TI525/TI535 Hardware and Installation Manual

Order Manual Number: PPX:505-8103-3

Refer to this history in all correspondence and/or discussion about this manual.

Event	Date	Description
Original Issue	09/88	Original Issue (2586652-0001)
Second Edition	11/90	Second Edition (2586652-0002)
Third Edition	04/93	Third Edition (2586652-0003)

LIST OF EFFECTIVE PAGES

Pages	Description	Pages	Description
Cover/Copyright	Third Edition		
History/Effective Pages	Third Edition		
iii — viii	Third Edition		
Preface ix–x	Third Edition		
1-1 — 1-10	Third Edition		
2-1 — 2-7	Third Edition		
3-1 — 3-32	Third Edition		
4-1 — 4-13	Third Edition		
5-1 — 5-19	Third Edition		
A-1 — A-2	Third Edition		
B-1 — B-7	Third Edition		
C-1 — C-5	Third Edition		
Index-1 — Index-3	Third Edition		
Registration	Third Edition		

Contents

Preface

Chapter 1 Series 505 System Overview

1.1	Introduction	1-1
1.2	Features Of The TI525 And TI535	1-6
1.2.1	Program Software	1-8
1.2.2	Program Storage in EEPROM	1-8
1.2.3	Communication Ports	1-9
1.2.4	Battery Backup	1-9
1.2.5	Ladder Memory Protection	1-10

Chapter 2 Pre-installation Planning

2.1	Introduction	2-1
2.2	Safety Considerations	2-4
2.3	Enclosure Selection	2-6
2.4	Grounding And Wiring The Equipment	2-7
2.5	Temperature Considerations	2-7

Chapter 3 Installation

3.1	Installing The Base Assemblies	3-1
3.1.1	Installing Base Hardware	3-3
3.1.2	Rack or Panel Mounting	3-3
3.2	Handling Series 505 Modules	3-4
3.3	Setting TI525 Dipswitches	3-5
3.3.1	Setting Port Baud Rate — TI525 Models	3-6
3.3.2	Selecting Battery Backup — TI525 Models	3-7
3.3.3	Selecting Ladder Memory Protection — TI525 Models	3-8
3.3.4	Downloading Preset Constants — TI525 Models	3-9
3.4	Setting TI535 Dipswitches	3-10
3.4.1	Selecting I/O Type — TI535 Models	3-11
3.4.2	Downloading Preset Constants — TI535 Models	3-12
3.4.3	Setting Highest I/O Base Number — TI535 Models	3-13
3.4.4	Selecting Battery Backup — TI535 Models	3-14
3.4.5	Setting Communication Port Baud Rate — TI535 Models	3-15
3.4.6	Selecting Ladder Memory Protection — TI535 Models	3-16
3.5	Installing The Battery	3-17
3.5.1	Model TI525 Battery Installation	3-17

3.5.2	Model TI535 Battery Installation	3-18
3.6	Installing System Components	3-19
3.6.1	Numbering Series 505 I/O Points	3-22
3.6.2	Guidelines For Installing Series 505 Modules	3-23
3.6.3	Installing the Power Supply	3-25
3.6.4	Installing the PLC	3-27
3.6.5	Installing the I/O Modules	3-29
3.6.6	Installing the Base Controllers	3-32

Chapter 4 EPROM/EEPROM Operation

4.1	Introduction	4-1
4.2	Installing An EPROM/EEPROM In TI525 Models	4-4
4.3	Installing An EPROM/EEPROM In TI535 Models	4-6
4.4	Programming The EEPROM	4-8
4.5	Reporting EEPROM Status	4-10
4.5.1	Status Word Six (STW06)	4-10
4.5.2	Status Words Seven to Nine (STW07–STW09)	4-11
4.6	Editing/Saving Programs Using An EPROM/EEPROM	4-12

Chapter 5 Startup / Troubleshooting

5.1	Start-up Procedures	5-1
5.2	Using The Troubleshooting Tools	5-4
5.2.1	Reading the LED Indicators	5-4
5.2.2	Executing the Auxiliary Functions	5-5
5.2.2.1	AUX Function 29 (Show PLC Diagnostic Cell)	5-5
5.2.2.2	AUX Function 25 (Display Failed I/O)	5-6
5.2.2.3	AUX Function 20 (Run PLC Diagnostics)	5-6
5.2.2.4	AUX Function 11 (Partial Restart)	5-6
5.2.2.5	AUX Function 12 (Complete Restart)	5-6
5.2.2.6	AUX Function 10 (Power-up Restart)	5-7
5.2.3	Troubleshooting with Status Words	5-8
5.2.3.1	Status Word One (STW01)	5-8
5.2.3.2	Status Word Two (STW02)	5-9
5.2.3.3	Status Word Six (STW06)	5-10
5.2.3.4	Status Words Seven to Nine (STW07–STW09)	5-11
5.2.3.5	Status Word Ten (STW10)	5-11
5.2.3.6	Status Words Eleven to Eighteen (STW11–STW18)	5-12
5.2.4	Clearing PLC Fatal Errors	5-14
5.2.5	Troubleshooting the EPROM/EEPROM	5-17
5.2.6	Troubleshooting the Power Supply	5-18
5.2.7	Spare Parts	5-19

Appendix A Specifications

A-1

Appendix B Grounding And Electrical Guidelines

B.1	Introduction	B-1
-----	--------------------	-----

B.2	Grounding	B-1
	B.2.1 Single Point Grounding	B-1
	B.2.2 Guidelines for Ground Connections	B-2
B.3	Wiring Guidelines	B-4
B.4	Minimizing Electrical Noise	B-5
	B.4.1 Definition and Source	B-5
	B.4.2 Correcting Noise Problems	B-6
	B.4.2.1 Noise Suppression	B-6
	B.4.2.2 Isolation	B-7
Appendix C	Series 500/505 I/O Power Consumption	C-1

List of Figures

1-1	TI525 and TI535 Controllers	1-2
1-2	Functional Relationship of Series 505 Components	1-4
2-1	Operator Safety Switch	2-4
2-2	Emergency Stop Switch	2-5
2-3	JOG or INCH Switch	2-6
3-1	Series 505 Bases	3-1
3-2	Mounting Dimensions for the Series 505 Bases	3-2
3-3	Locations of the Dipswitches for the TI525 Models	3-5
3-4	Switch Settings — TI525 RS-232-C/423 and RS-422 Ports	3-6
3-5	Switch Settings — TI525 Battery Backup	3-7
3-6	Switch Settings — TI525 L-Memory Protection	3-8
3-7	Switch Settings — TI525 Download/Retain Presets	3-9
3-8	Locations of the Dipswitches for TI535 Models	3-10
3-9	Switch Settings — TI535 Download/Retain Presets	3-12
3-10	Switch Settings — TI535 Highest-Numbered Logical Base	3-13
3-11	Switch Settings — TI535 Battery Backup	3-14
3-12	Switch Settings — TI535 RS-232-C/RS-423 and RS-422 Ports	3-15
3-13	Switch Settings — TI535 L-Memory Protection	3-16
3-14	Battery Location for TI535 Models	3-18
3-15	Definition of the Series 505 Logical Base	3-19
3-16	System With Local I/O Only	3-20
3-17	Systems with Local and Distributed I/O	3-21
3-18	Power Supply Jumper	3-25
3-19	Location of Power Supply in Base	3-26
3-20	Location of PLC in Base	3-27
3-21	Location of I/O Modules in Base	3-29
4-1	TI525 EPROM/EEPROM Socket and Jumper Pins	4-5
4-2	TI535 EPROM/EEPROM Socket and Jumper Pins	4-7
4-3	Format of Status Word Six (STW06)	4-10
5-1	Example of AUX Function 29 Screen	5-5
5-2	Format of Status Word One (STW01)	5-8
5-3	Format of Status Word Two (STW02)	5-9
5-4	Format of Status Word Six (STW06)	5-10
5-5	Format of Status Word Ten (STW10)	5-11
5-6	Format of Status Words Eleven to Eighteen (STW11–18)	5-12
5-7	Example of a Status Word With a Bit Set	5-13
B-1	Sample Ground Connections	B-3
B-2	Examples of Noise Snubbing	B-6

List of Tables

1-1	Model Differences	1-6
1-2	TI525/TI535 Instruction Set	1-7
3-1	Pin-out for the RS-232-C/RS-423 Port	3-28
3-2	I/O Module Point Assignments	3-31
4-1	Changes in Mode and Memory After Power Up	4-3
5-1	LED Indicators	5-4
5-2	Effects of Aux Functions on Memory Locations	5-7
C-1	Series 505 Component Power Requirements	C-1
C-2	Series 500 Component Power Requirements	C-4

PREFACE

INTRODUCTION

This manual gives detailed instructions for the installation and operation of the Series 505™ family of programmable logic controllers (PLCs). Both the SIMATIC® TI525™ and the SIMATIC® TI535™ PLCs and their support equipment are discussed. The topics are listed below by chapter.

- Chapter 1 describes the features of the various models of the TI525 and TI535 PLCs.
- Chapter 2 is a guide to pre-installation planning to facilitate the establishment of a safe and efficient system of equipment control.
- Chapter 3 contains the details of installing the system components.
- Chapter 4 presents the installation and operation of EPROMs and EEPROMs.
- Chapter 5 describes the system start-up procedure and gives information for troubleshooting.
- Appendix A lists the specifications for the TI525 and TI535 PLCs.
- Appendix B gives grounding and other electrical guidelines.
- Appendix C lists the power requirements for all currently available Series 505 and Series 500™ I/O modules.

REFERENCES

Consult the manuals listed below for further information on installing, programming, and troubleshooting your Series 505 hardware.

- *SIMATIC® TI505™ Programming Reference Manual*
(PPX:505-8104-3)
- *TIWAY™ Systems Manual* (TIWAY-8101)
- *CVU1000™ & CVU10000™ User Reference Manual*
(PPX:CVU10-8101-2)
- The I/O module user manuals that are appropriate for your system.
- The user manuals for your release of TISOFT™ .

CHAPTER 1

SERIES 505 SYSTEM OVERVIEW

1.1 INTRODUCTION

The TI525/TI535 Programmable Controllers (PLCs) and their support equipment are computer-controlled systems that are capable of managing the operation of other systems. These PLCs execute the same functions as relays, static control, or card logic control systems. They can detect the change in state of input signals from such devices as pushbuttons, limit switches, and sensors. Acting on this information and executing a Relay Ladder Logic (RLL) program stored in memory, the TI525/TI535 PLCs produce output signals to drive motor starters, solenoids, and pilot lights, etc., that regulate the operation of various pieces of equipment.

The TI535 is an enhanced version of the TI525 that offers the following features:

- The scan time for Boolean logic is reduced significantly (from 4 milliseconds per K words of memory to less than 1 millisecond per K words of memory).
- A communication port baud rate of 19,200 provides faster communication with the Video Programming Unit (VPU™) and other operator interfaces.

FEATURES

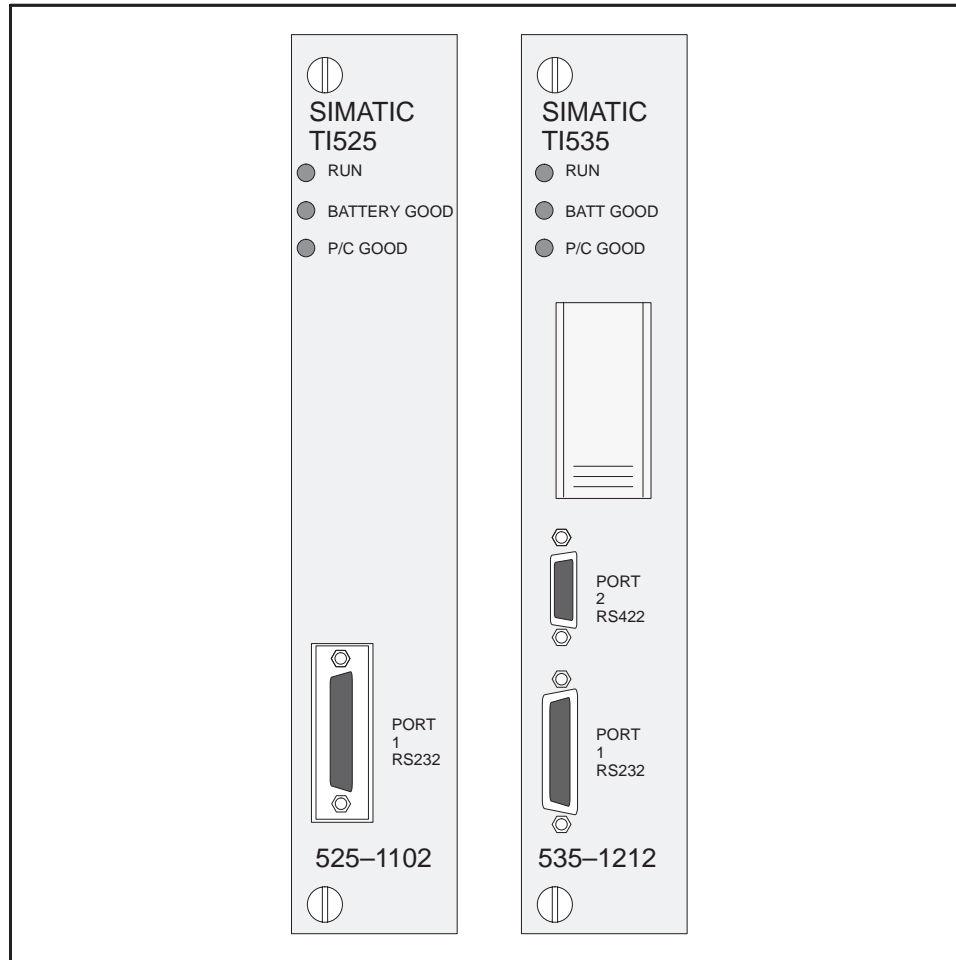

Figure 1-1 TI525 and TI535 Controllers

The Series 505 product line is designed for use in small to medium applications such as discrete, word, and analog control. Components include the TI525 and TI535 PLCs, shown in Figure 1-1, and the support devices that provide operator communication, I/O control, and power.

Operator communication may take place through any of the following devices:

- IBM® PC/XT Computer or a 100% compatible computer with TISOFT
- Video Programming Unit (VPU)
- Handheld Intelligent Terminal (HIT 500-1101)
- Control Vision Unit (CVU)

FEATURES

You may use a DEC® VAX™ Computer to develop an RLL program that can be transferred to a TI525/TI535 PLC with a VPU. You can provide communication between devices through the TIWAY industrial local area network.

See the references listed in the Preface of this manual for information on these systems.

I/O control for the Series 505 takes place through individual Series 505 I/O modules. A full line of discrete, analog, word, and intelligent I/O modules are available that can handle almost any input or output specifications. These I/O modules are rugged, plug-in devices capable of functioning in harsh environments.

I/O modules are grouped into local and distributed I/O categories depending upon their physical location. The local I/O consists of those modules installed in the same base assembly as the PLC. The TI525-1102 can support up to 512 local I/O points. You can create a distributed I/O system for all other models by connecting up to 14 additional base assemblies. All current versions of the TI525 and TI535 PLCs support up to 1023 I/O points, in both local and distributed bases.

When additional bases are connected to the system, distributed I/O is managed through communication between base controllers — the I/O Channel Controller (IOCC) and one or more Distributed Base Controllers (DBC). The DBC (PPX:505-6840) in each distributed base assembly transmits data from the I/O modules in that base assembly to the IOCC (PPX:505-6830), which occupies the same base assembly as the PLC. Your TI525/TI535 PLC can address distributed bases up to 1300 feet (396m) away.

A diagram of the TI525/TI535 system which shows the functional relationship of all the system components is shown in Figure 1-2.

FEATURES

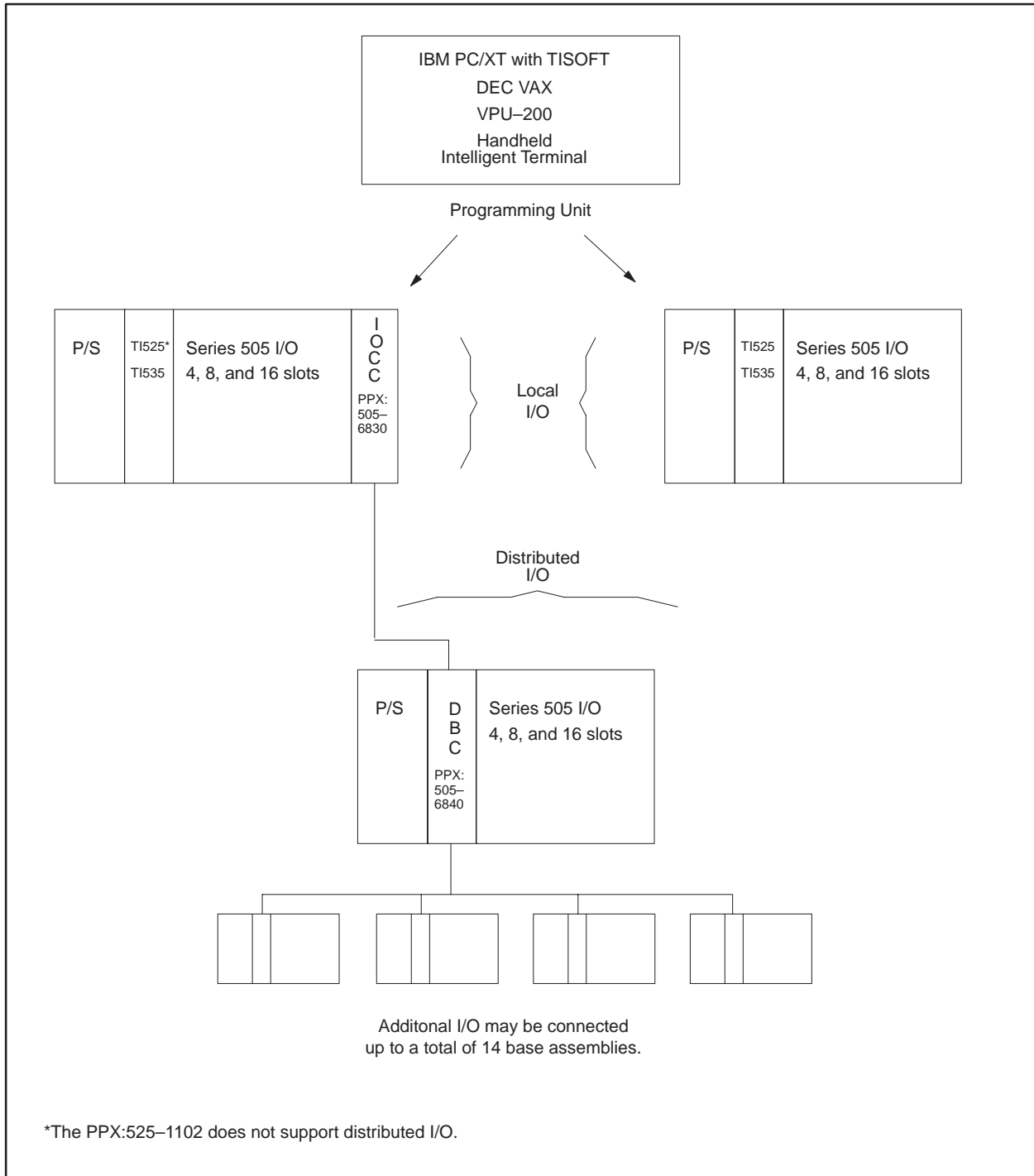

Figure 1-2 Functional Relationship of Series 505 Components

FEATURES

The power supply provides up to 55 watts at +5 VDC and 3.75 watts at -5 VDC for use by the PLC, the base controllers, and the I/O modules. The PPX:505-6660 power supply operates at either 110 V or 220 VAC on user-supplied power. A jumper on the inside of the back of the module is used to select voltage. The PPX:505-6663 power supply operates on 24 VDC user-supplied power.

All Series 505 hardware is compatible with International Standards double-Eurocard (DIN standard 41494).

FEATURES

1.2 FEATURES OF THE TI525 AND TI535

Two models of the TI525 and one of the TI535 are currently available. Differences between these models are given in Table 1-1. The TI525/TI535 RLL instruction set is listed in Table 1-2.

Table 1-1 Model Differences

Features	PLC Model					
	PPX:525	PPX:525	PPX:525	PPX:525	PPX:535	PPX:535
	1102	1104	1208*	1212*	1204*	1212
Ladder Logic Size	2048	4096	8192	12000	4096	12000
Physical I/O	512	1023	1023	1023	1023	1023
Discrete/Word I/O	1023	1023	1023	1023	1023	1023
Control Relays	511	511	511	1023	511	1023
V Memory (words)	1024	2048	4096	5120	2048	5120
Timers/Counters	256	256	256	400	256	400
Drums	30	30	30	30	30	30
One Shot	128	128	256	400	128	400
SHRB/SHRW	30	45	60	75	45	75
MWTT/MWFT	30	45	60	75	45	75
JMP (nested)	8	8	8	8	8	8
MCR (nested)	8	8	8	8	8	8
SKP/LBL	255	255	255	255	255	255
Status Words	11	18	18	18	18	18
RS-232-C/423 Ports	1	1	1	1	1	1
RS-422 Ports	0	0	1	1	1	1

* These models are now obsolete.

FEATURES

Table 1-2 TI525/TI535 Instruction Set

Program Control Instructions	
Jump (JMP)	End, Conditional (ENDC)
Label (LBL)	End, Unconditional (END)
Master Control Relay (MCR)	Skip (SKP)
Math Instructions	
Add (ADD)	Divide (DIV)
Subtract (SUB)	Multiply (MULT)
Compare (CMP)	Square Root (SQRT)
Bit Instructions	
Bit Clear (BITC)	Bit Set (BITS)
Bit Pick (BITP)	Bit Shift Register (SHRB)
Word Instructions	
Convert Binary to BCD (CDB)	Word Rotate (WROT)
Convert BCD to Binary (CBD)	Word Exclusive OR (WXOR)
Word AND (WAND)	Word Shift Register (SHRW)
Word OR (WOR)	
Move Instructions	
Load Data Constant (LDC)	Move Word (MOVW)
Move Discrete Image Register to Word (MIRW)	Move Word To Discrete Image Register (MWIR)
Move Word To Table (MWTT)	Move Word From Table (MWFT)
Counter/Timer	
Counter (CTR)	Up/Down Counter (UDC)
Timer (TMR)	One Shot (O/S)
Matrix Instructions	
Scan Matrix Compare (SMC)	Index Matrix Compare (IMC)
Drum Instructions	
Drum (DRUM)	Event Drum (EDRUM)

1.2.1 Program Software

The TI525/TI535 PLCs are programmed in standard relay ladder logic, and TISOFT programming software provides a means of entering, debugging, and documenting your RLL program. TISOFT is menu-driven, provides both RLL and advanced program special functions language, and permits you to add comments to instructions. Different versions of TISOFT are available. TISOFT1™ operates on the VPU200; TISOFT2™ is executed on an IBM PC/XT, and TISOFT3™ runs in an off-line mode on a DEC VAX computer.

You may also fully program the TI525/TI535 in Boolean symbolic code using the Handheld Intelligent Terminal.

In addition to the standard relay ladder logic, the TI525/TI535 programming instruction set offers more than 30 high-level, user-oriented operations. The box instructions replace programming steps that once required hundreds of words of memory. More importantly, these instructions permit you to use the power of the PLC to perform complex functions, which makes program development and debugging faster and easier.

1.2.2 Program Storage in EEPROM

The TI525/TI535 PLCs offer the option of saving your RLL program in a non-volatile form by downloading it to an Electrically Erasable Programmable Read Only Memory (EEPROM; PPX:2587681-8020) integrated circuit. A separate programming device is not necessary. Once programmed, an EEPROM may be removed and used in any of the TI525/TI535 or SIMATIC® TI530T™ models, provided the program is compatible with the system's capabilities.

An EPROM may also be used to execute a program in a TI525 or TI535 PLC. The program must be copied from an EEPROM described above or by an EPROM programmer before it is installed on the TI525/TI535 CPU board.

To ensure equipment compatibility use only the EPROM model supplied by your distributor: (PPX:2587681-8012).

1.2.3 Communication Ports

Each TI525/TI535 PLC has a 25-pin RS-232-C/RS-423 compatible port configured as Data Terminal Equipment (DTE). This port may be used for communicating with programming equipment such as the Timer/Counter Access Module (TCAM), the VPU, a CVU, or a modem up to 50 feet (15 m) away.

An RS-422 compatible port is also available on the PPX:535-1212. This port may be used for communicating with a modem and allows communication to a distance up to 1000 feet (305 m).

1.2.4 Battery Backup

A 3.0 V lithium battery (PPX:2587678-8005) protects the following information during a power cycle:

- RLL program
- Timer/counter preset and current values
- Drum preset preset and current values
- Word I/O values
- Variable (V) memory values
- Retentive control relay status
- States of forced I/O
- Scan time
- I/O Configuration data

Battery memory backup typically lasts six months at temperatures ranging from 0° to 60°C.

1.2.5 Ladder Memory Protection

A memory protection dipswitch provides protection for the RLL program. When the switch is in the ON position, the program cannot be changed by a programming device that is connected to the PLC through one of the communication ports.

NOTE

The memory protection dipswitch does not prevent forcing I/O, changing variable memory, or switching the PLC from PROGRAM to RUN mode. These actions may be made by a programming device connected to the PLC, or a special function I/O module designed for this type of interface to the PLC, e.g., a Network Interface Module. The RLL can also be changed through a special function module, even when the memory protection is enabled.

PRE-INSTALLATION PLANNING

This chapter presents recommended installation practices and procedures. Since no two applications are identical, these recommendations are guidelines.

2.1 INTRODUCTION

Preparing the site for installation of your TI525/TI535 PLC consists of the following:

- Defining the control requirements
- Determining the number of PLCs needed
- Determining the panel and grounding layout

You should define the control requirements in terms of the number and type of inputs and outputs. Once the inputs and outputs have been defined, calculate the number of I/O modules and bases that are needed. When the number of PLCs, bases, and I/O modules is known, determine the power requirements and mounting space needed. Space in the base assembly may be a limiting factor that you should consider as you plan your system. This is particularly true if several double-wide modules are needed.

It is useful to calculate a power budget for each base prior to installation. The power requirements of all modules must be included in the calculations — the PLC, the base controllers, as well as the I/O modules. The user-supplied power to individual modules is not a part of the power budget calculation.

To help ensure reliable system operation, the total power required for the PLC, the I/O controllers, and the I/O modules must not exceed the total power available from the system power supply.

WARNING

Control devices can fail in an unsafe condition. This means that, unless proper safeguards are incorporated by the user, certain malfunctions of these devices could lead to a sudden equipment startup. Such a startup could result in property damage and/or severe physical injury to the equipment operator.

PRE-INSTALLATION

If you, or your company, use any programmable controllers with equipment which requires an operator or attendant, you should be aware that this potential safety hazard exists and take appropriate precautions. Although the specific design steps depend on your particular application, the following precautions generally apply to installation of solid-state programmable control devices.

These precautions conform to the guidelines for installation of Programmable Controllers as recommended in the NEMA ICS 3-304 Programmable Control Standards.

ICS 3-304.81 Safety Recommendations:

Consideration should be given to the use of an emergency stop function which is independent of the programmable controller.

Where the operator is exposed to the machinery, such as in loading or unloading a machine tool, or where the machine cycles automatically, consideration should be given to the use of an electromechanical override or other redundant means, independent of the programmable controller, for starting and interrupting the cycle.

If provision is required for changing programs while the equipment is in operation, consideration should be given to the use of locks or other means of assuring that such changes can be made only by authorized personnel.

*These recommendations are intended as safeguards against the failure of critical components and the effects of such failures or the inadvertent errors that might be introduced if programs are changed while the equipment is in operation.**

*The ICS 3-304.81 Safety Recommendations are reproduced by permission of the National Electrical Manufacturers Association from NEMA ICS 3-304, Programmable Controller Standard.

2.2 SAFETY CONSIDERATIONS

Pre-installation planning and site preparation must include consideration of hazards to personnel during a system failure. The equipment connected to the TI525/TI535 PLC should include interlocks and safety switches to prevent operation during a system failure. Although the specific steps depend on the application, the general precautions include the following:

- Provide a means for disconnecting power—independent of the PLC—from the output loads when a machine is not operating, or when it is necessary for the operator to reach into the machine. Power must be removed by a non-semiconductor switch or a physically-wired relay contact, placed to interrupt power to the output. It is not sufficient to rely solely on the PLC for this function. Figure 2-1 illustrates an operator safety switch.

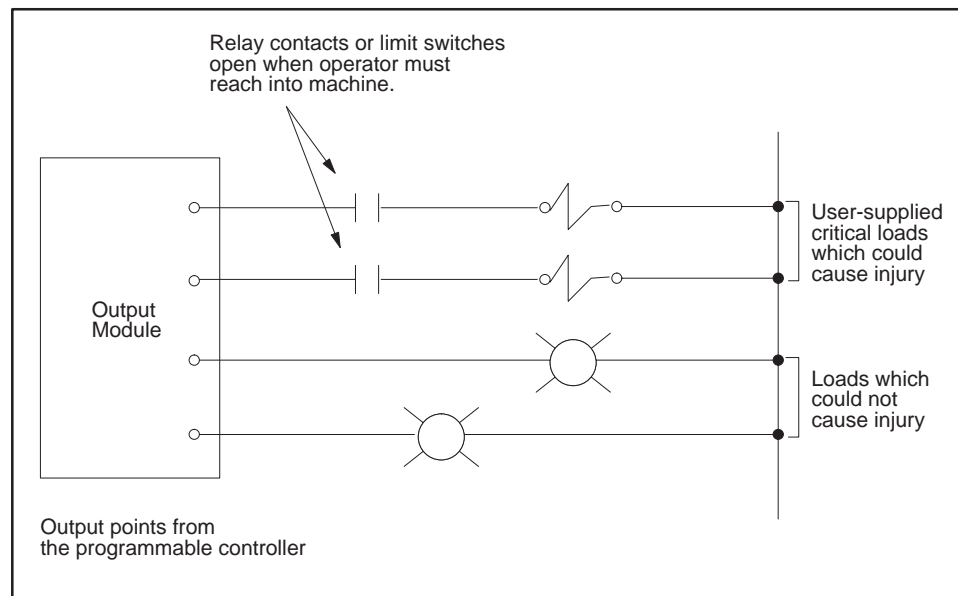

Figure 2-1 Operator Safety Switch

PRE-INSTALLATION

- Provide a means for removing power from the output if an emergency condition occurs with the machine during operation. Do this by disconnecting output power with a non-semiconductor switch or hard-wired relay contact, not through the programmable control system. This type of switch is shown in Figure 2-2.

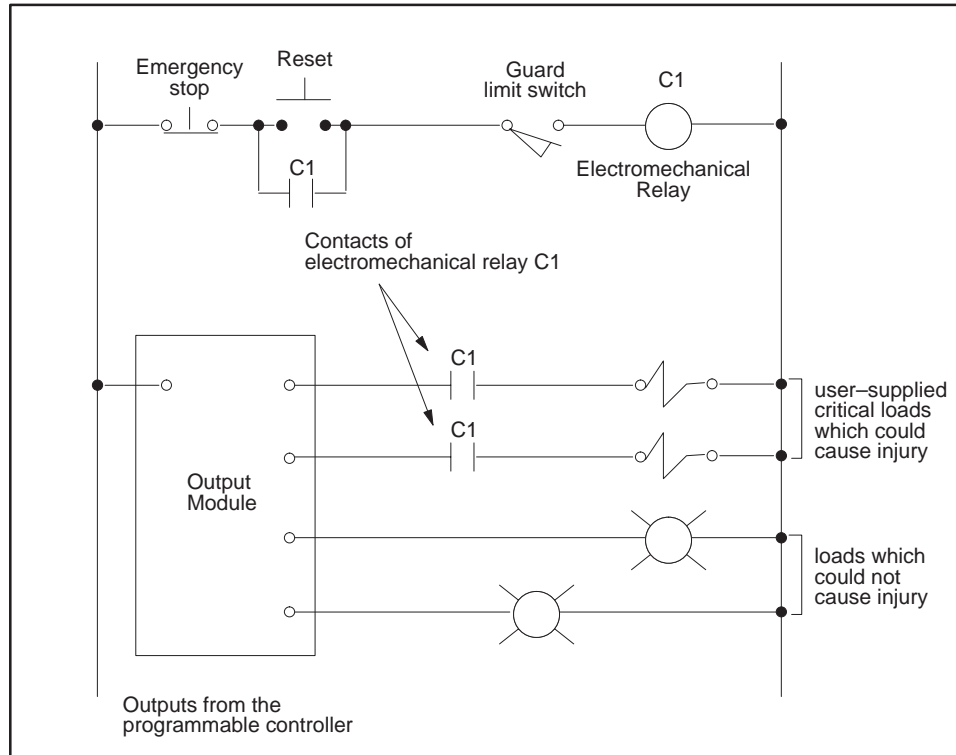

Figure 2-2 Emergency Stop Switch

- Bypass the programmable control system with an external JOG or INCH switch during machine loading or setup operations. See Figure 2-3.

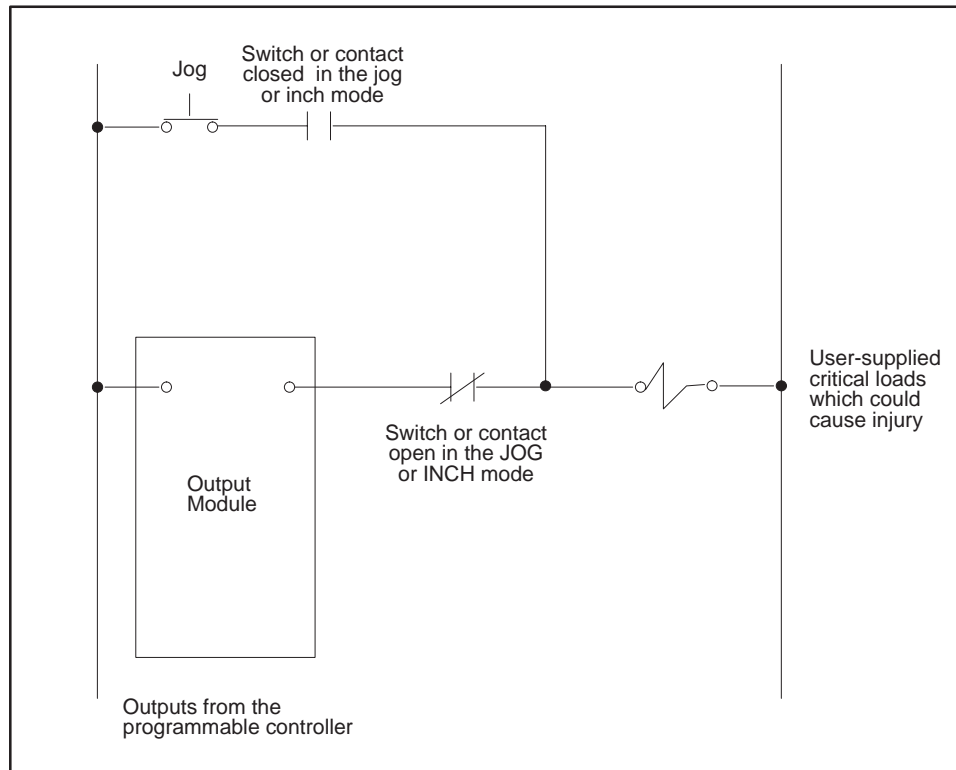

Figure 2-3 JOG or INCH Switch

2.3 ENCLOSURE SELECTION

As a minimum, an enclosure for a PLC should provide the following:

- Easy access to components
- A common ground potential on the cabinet
- A secure vertical panel or rails
- Conformance to electrical standards
- An electromagnetic shield
- Access restricted to authorized personnel only
- Protection from dust, dirt and moisture in an industrial environment

Mount the TI525/TI535 components in a dustproof and drip tight enclosure such as the NEMA Type 12 enclosure. The enclosure must provide a minimum depth of 25.4 cm (10 in) from the panel to the inside surface of the enclosure door. The enclosure should be located so that the doors may be opened fully, permitting easy access to the PLC, wiring, and components. If environmental conditions permit, a 19-inch rack may be used instead of a NEMA enclosure. Use the 16-slot I/O base PPX:505–6516 for 19-inch rack installations.

2.4 GROUNDING AND WIRING THE EQUIPMENT

A good grounding system is essential for proper operation of a PLC system and should be one of the most important considerations in planning your installation. The structural ground present in many industrial environments does not provide an adequate ground return where direct wire connection is not feasible. Appendix B is a discussion of grounding, electromagnetic interference (EMI), and other electrical considerations. See the guidelines in Appendix B to be certain to meet all grounding and wiring requirements.

2.5 TEMPERATURE CONSIDERATIONS

When preparing your installation, plan for an adequate air flow to ensure proper cooling of equipment. Do not permit the convective cooling of the PLC to be hindered. Unless ambient temperatures are extremely high, a fan or air-conditioned cooling is unnecessary for keeping TI525/TI535 PLCs below their maximum-rated operating temperature of 60°C.

For one local base and one distributed base located in the the bottom half of a 7-foot, 19-inch rack, place equipment that dissipates no more than 325 W in the top half, above the Series 505 bases, assuming a 25°C external ambient temperature. If you must exceed these guidelines, use cooling equipment to lower the equipment temperature to the recommended level.

3.1 INSTALLING THE BASE ASSEMBLIES

The PLC, I/O controllers, power supply, and I/O modules are mounted in Series 505 base assemblies. Three Series 505 base assembly models are currently available:

- PPX:505-6504, 4 I/O slots
- PPX:505-6508, 8 I/O slots
- PPX:505-6516, 16 I/O slots (19-inch rack compatible)

Each base has slots reserved for the power supply and for the PLC, and 4, 8, or 16 I/O module slots, depending upon the base model. Refer to Figure 3-1.

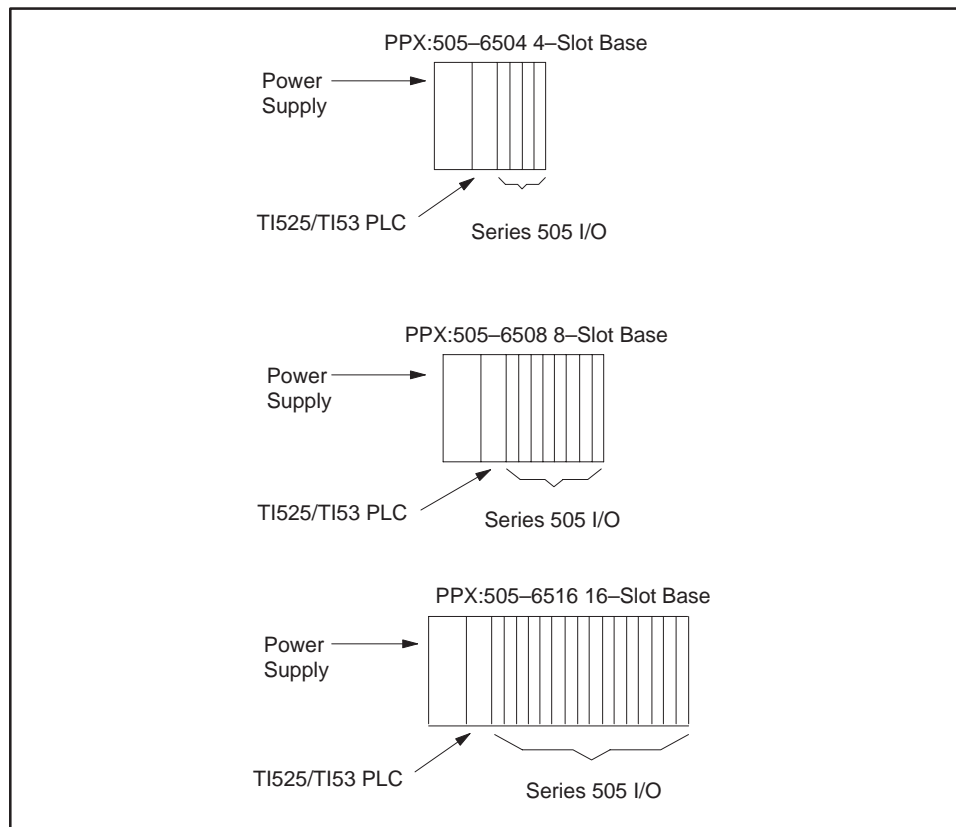

Figure 3-1 Series 505 Bases

INSTALLATION

All Series 505 bases may be panel-mounted. The PPX:505-6516 base may also be mounted in a 19-inch rack. The mounting brackets are included with the Series 505 base assembly. Figure 3-2 shows the dimensions and screw positions.

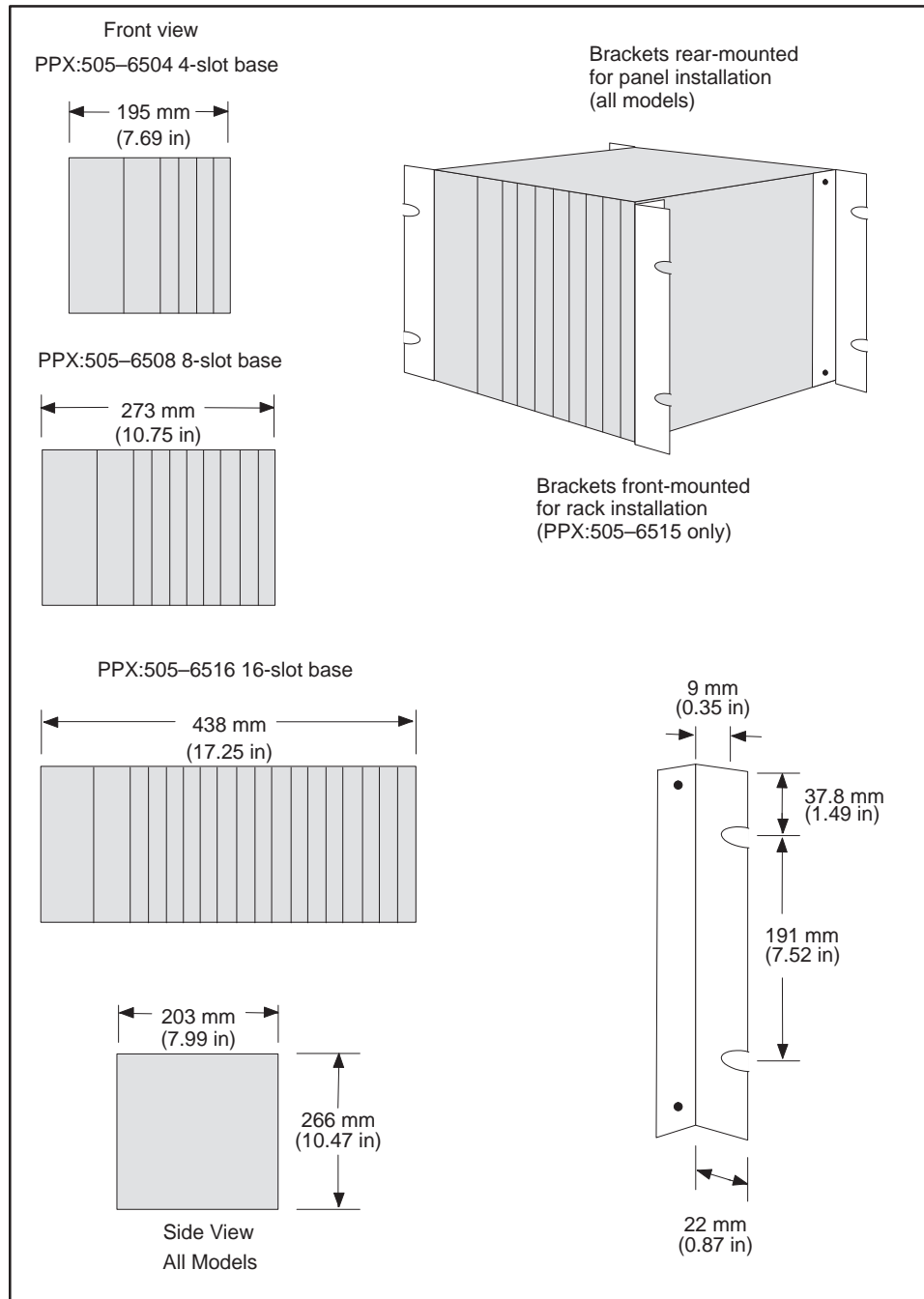

Figure 3-2 Mounting Dimensions for the Series 505 Bases

INSTALLATION

3.1.1 Installing Base Hardware

For rack or panel mounting, place the brackets in the desired position on the Series 505 base (on the front for rack mounting, or on the back for panel mounting) as shown in Figure 3-2. Insert the enclosed screws through the brackets into the predrilled holes in the base and tighten.

3.1.2 Rack or Panel Mounting

If you are mounting your base on a predrilled rack, align the brackets with the rack, then insert and tighten the screws.

Before mounting the base to a panel, you need to measure for and drill screw holes. Refer to Figure 3-2 for screw locations.

On the front of the base is a ground lug which you should connect to a single-point earth ground. (Refer to Appendix B for further grounding guidelines.)

CAUTION

Each base has a plastic dustguard covering the top grill. The dustguard prevents debris from falling into the base during installation. After the entire system installation is complete, and BEFORE ENABLING POWER TO THE SYSTEM, be sure to remove the dustguard from each base. This will allow proper air flow and prevent serious complications due to overheating.

3.2 HANDLING SERIES 505 MODULES

Many integrated circuit (IC) devices are susceptible to damage by the discharge of static electricity. Follow the suggestions listed below to reduce the probability of damage to these devices when you are handling a PLC, an I/O controller, or any of the I/O modules. **To minimize risk of shock hazard, make certain power to the PLC system is turned off.**

WARNING

To minimize the risk of shock hazard, make certain power to the PLC system is turned off.

Both the module and the person handling the module should be at the same ground potential. To accomplish this, ensure that:

- The module is transported in an antistatic container or antistatic material.
- The work area has a conductive pad with a lead connecting it to a common ground.
- You are grounded by making contact with the conductive pad and/or by wearing a grounded wrist strap.

CAUTION

The following precautions, although less effective, may be taken to minimize the possibility of component damage resulting from electrostatic discharge. See Appendix B for grounding guidelines.

- To discharge static electricity, touch a grounded piece of metal before touching the circuit board or any of its components.
- Wear non-synthetic clothing.
- Handle all modules by the external casing, and avoid contact with the circuit board or any of its components.

INSTALLATION

3.3 SETTING TI525 DIPSWITCHES

You determine operational parameters for the TI525 by setting switches on two dipswitches. For the TI525 PLCs, these dipswitches are located on the printed circuit board (PCB). Refer to Figure 3-3.

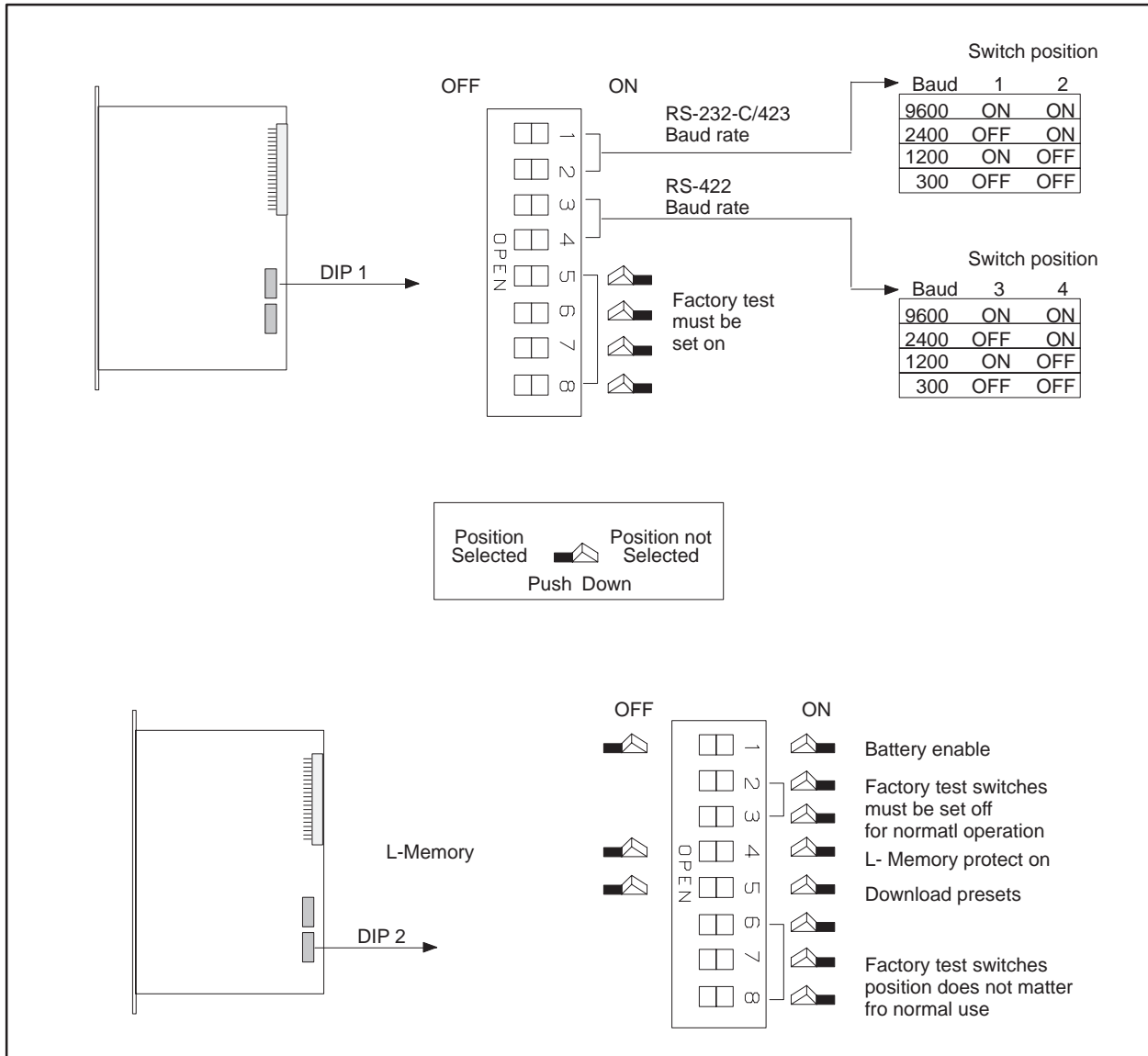

Figure 3-3 Locations of the Dipswitches for the TI525 Models

INSTALLATION

3.3.1 Setting Port Baud Rate — TI525 Models

Figure 3-4 shows the baud rate switch assignments for the communication ports. Switches 1 and 2 on the first switch bank (DIP 1) set the baud rate for the RS-232-C/423 port (Port 1). Switches 3 and 4 on DIP 1 set the baud rate for the RS-422 port (Port 2). Switch position does not matter if a device is not connected to the port.

You need to set only switches 1 and 2 for PPX:525–1102 and PPX:505–1104 models which have only an RS-232-C/RS-423 port.

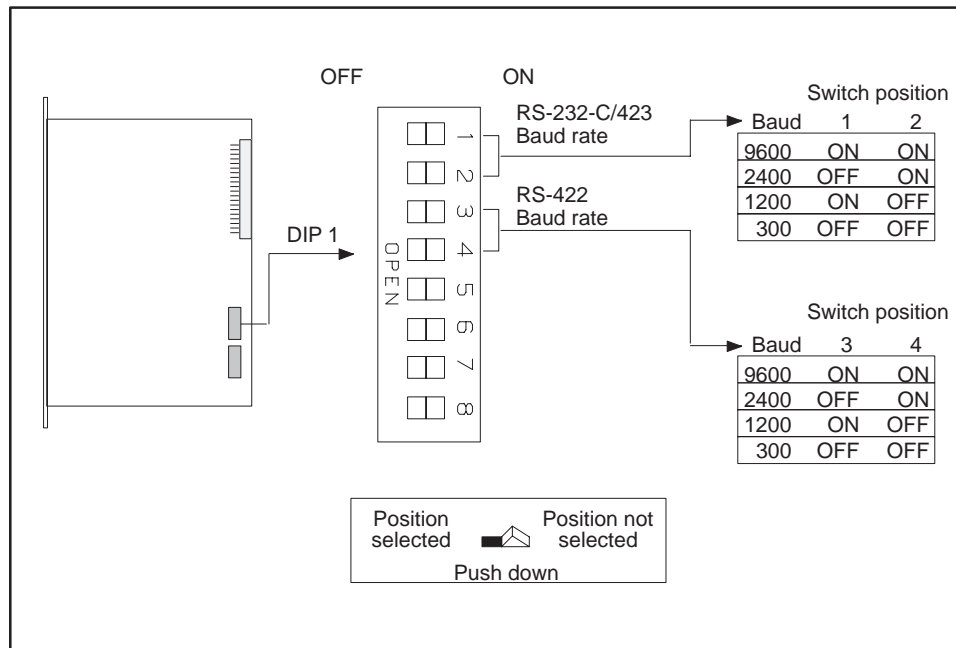

Figure 3-4 Switch Settings — TI525 RS-232-C/423 and RS-422 Ports

NOTE

Switches 5, 6, 7, and 8 on the first bank (DIP 1) are reserved for factory testing and should all be turned ON.

3.3.2 Selecting Battery Backup — TI525 Models

Switch 1 on the second dipswitch assembly (DIP 2) enables or disables the battery backup function. With the battery backup enabled, cycling power does not alter the following information:

- RLL program
- Timer/counter preset and current values
- Drum preset preset and current values
- Word I/O values
- Variable (V) memory values
- Retentive control relay status
- States of forced I/O
- Scan time
- I/O Configuration data

If you power up a TI525 without a good battery installed or with the battery backup dipswitch turned OFF, the PLC clears memory.

To allow for battery replacement, the TI525 is designed to retain memory for at least 10 minutes while powered down, even with a bad battery. If the PLC is powered down without a good battery for longer than 10 minutes, at power-up the PLC detects whether or not memory is valid. If memory is not valid, then the PLC clears memory upon power-up.

Refer to Figure 3-5. Turn switch 1 ON to enable the battery backup. Turn switch 1 OFF to disable battery backup.

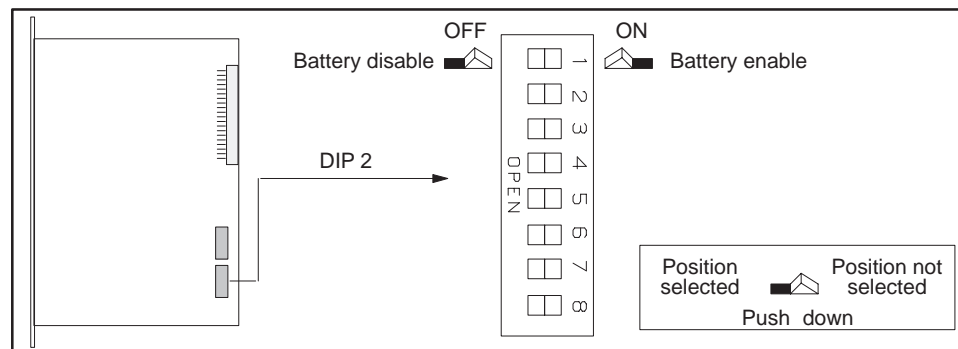

Figure 3-5 Switch Settings — TI525 Battery Backup

NOTE

Switches 2, 3, 6, 7, and 8 on DIP 2 are reserved for factory testing. Switches 2 and 3 should be turned off. The position of switches 6, 7, and 8 do not matter for normal operation.

3.3.3 Selecting Ladder Memory Protection — TI525 Models

Switch 4 on DIP 2 prevents modifications to the RLL program in ladder memory. Your programming unit refers to this switch as a keylock.

Refer to Figure 3-6. Turn switch 4 ON to prohibit changes to the program. Turn switch 4 OFF to permit program editing.

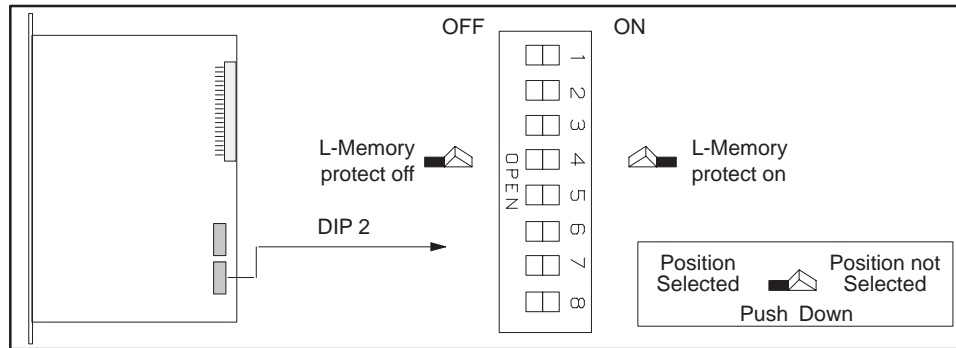

Figure 3-6 Switch Settings — TI525 L-Memory Protection

NOTE

Turning the L-memory protect switch on does not prevent forcing I/O, changing variable memory, or switching the PLC from PROGRAM to RUN mode. These actions may be initiated with a programming device connected to the PLC, or a special function I/O module designed for this type of interface to the PLC, e.g., a Network Interface Module.

The RLL can also be changed through a special function module, even when the memory protection is enabled with the keylock. Do not depend upon this switch to prevent personnel from interrupting your process.

INSTALLATION

3.3.4 Downloading Preset Constants — TI525 Models

The drum and timer/counter instructions have reserved sections of memory where preset variables are stored. These variables may be changed with an operator interface, such as a TCAM or VPU, or with an RLL instruction, without altering their value in the RLL program. If you cycle power or execute AUX Function 10 while the battery is enabled, switch 5 on DIP 2 determines whether the changed values in preset memory are retained or the original values are downloaded from the RLL program. If the battery is dead, low, or disabled, the preset values are always downloaded from the RLL program in an EPROM/EEPROM, if one is installed.

Refer to Figure 3-7. Turn switch 5 ON to have values downloaded from the RLL program. Turn switch 5 on DIP 2 OFF to have preset values retained.

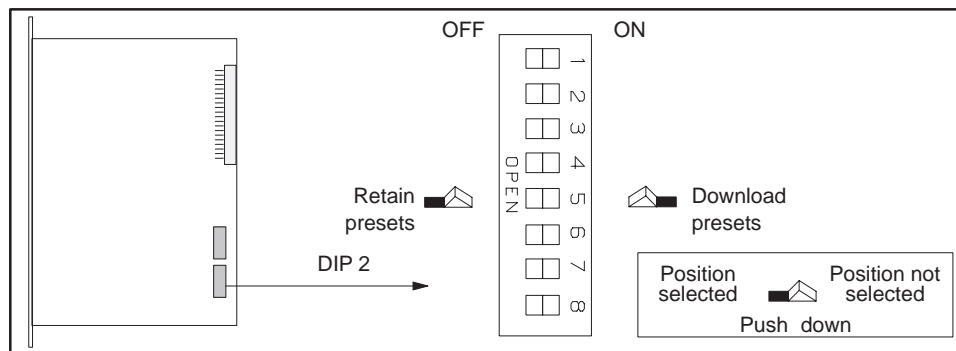

Figure 3-7 Switch Settings — TI525 Download/Retain Presets

NOTE

Executing AUX Function 12 (PLC Complete Restart) with your programming device causes the presets to be downloaded from the RLL program, regardless of the state of this dipswitch.

INSTALLATION

3.4 SETTING TI535 DIPSWITCHES

You determine operational parameters for the TI535 by setting switches on two dipswitch block assemblies. For the TI535 PLCs, this is done with one block of dipswitches located on the printed circuit board (PCB) and a second block located inside the battery door. Refer to Figure 3-8.

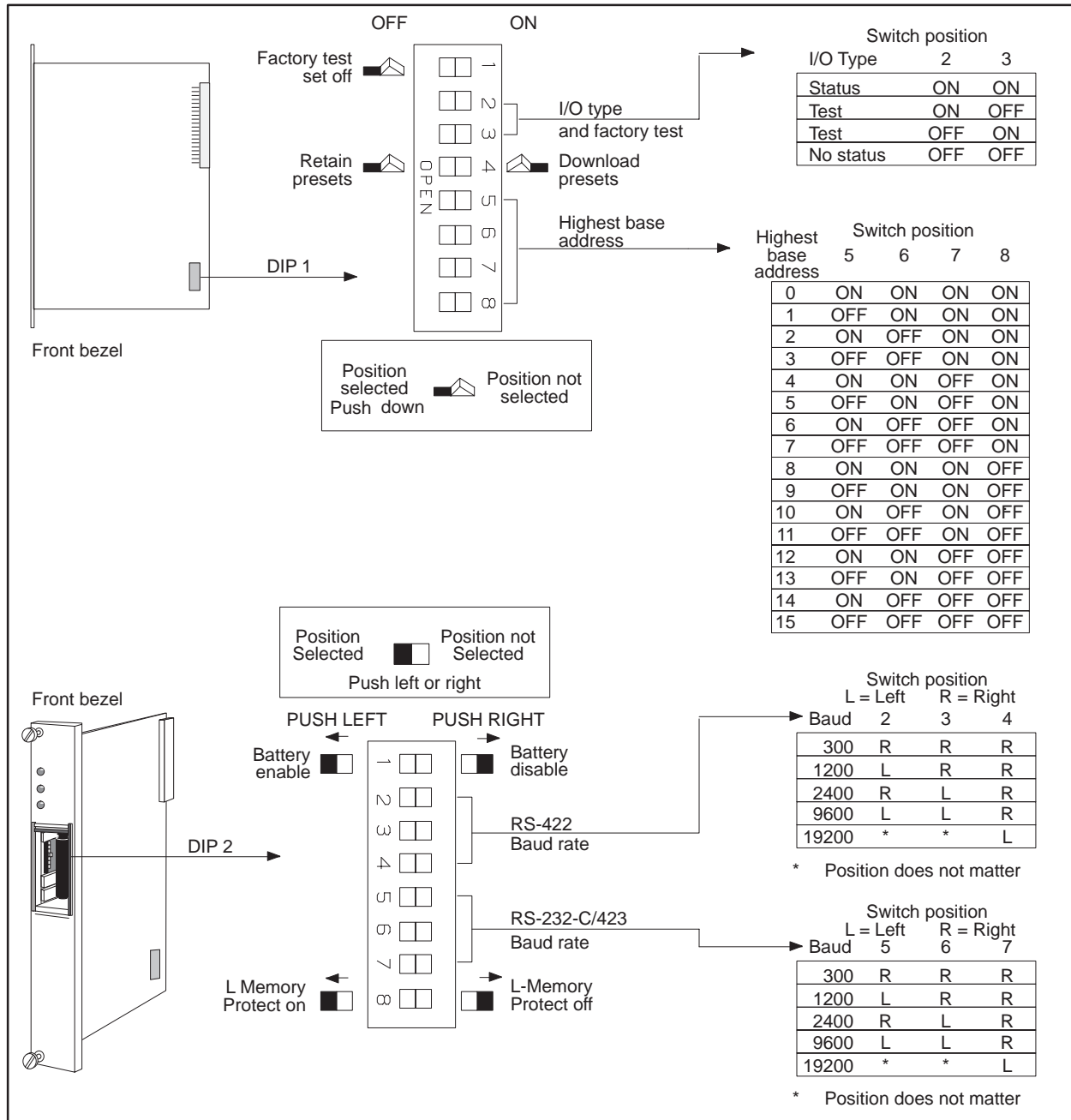

Figure 3-8 Locations of the Dipswitches for TI535 Models

NOTE

Switch 1 on the first dipswitch (DIP 1) is used for factory testing and should be turned OFF. Switches 2 and 3 are also reserved for factory testing and should be turned ON.

3.4.1 Selecting I/O Type — TI535 Models

Some earlier Series 505 I/O modules (manufactured prior to January 1, 1988) do not report module status to the CPU. Modules built after this date do report status. Complete the following steps to determine which type of I/O you have.

1. **Disconnect all user-supplied power from the base.**
2. Remove the I/O module.
3. Find the serial number label on the inside of the front bezel. If you have a number greater than XXXX8801XXXXXX, you have a module that reports status. If you have a serial number less than or equal to XXXX8712XXXXXX, you have a module that does not report status.

Switches 2 and 3 on DIP 1 determine whether the CPU expects the status to be reported.

If the switches are both ON, the CPU expects the status to be reported. If you install I/O modules that do not report status, the CPU reports an I/O mismatch and I/O failure.

If the switches are both OFF, the CPU does not expect the status to be reported. When both switches are off, you can use either type of I/O.

When the switches are mixed (ON/OFF or OFF/ON), the CPU is set for factory tests.

3.4.2 Downloading Preset Constants — TI535 Models

The drum and timer/counter instructions have reserved sections of memory where preset variables are stored. These variables may be changed with an operator interface, such as a TCAM or VPU, without altering their value in the RLL program. If you cycle power or execute AUX Function 10 or 11 while the battery is enabled, switch 4 on DIP 1 determines whether values in preset memory are retained or downloaded from the RLL program. If the battery is dead, low, or disabled, the preset values are always downloaded from the RLL program in an EPROM/EEPROM, if one is installed.

Refer to Figure 3-9. Turn switch 4 ON to have values downloaded from the RLL program. Turn switch 4 OFF to have preset values retained.

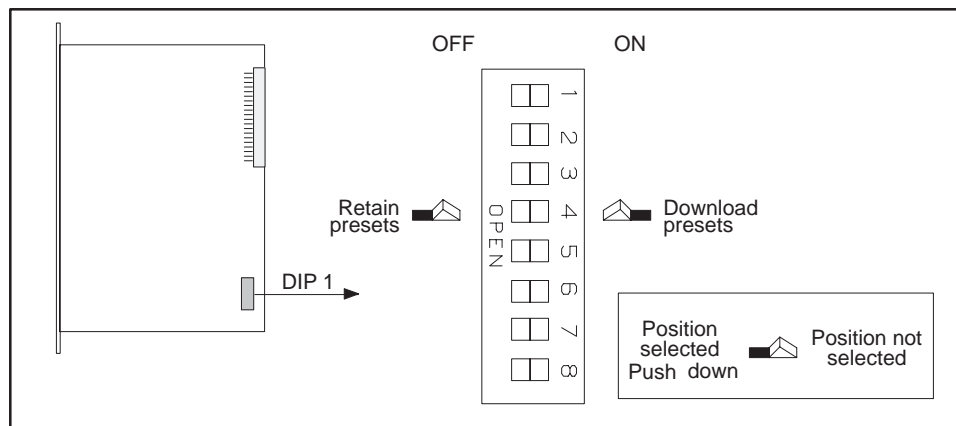

Figure 3-9 Switch Settings — TI535 Download/Retain Presets

NOTE

Executing AUX Function 12 (PLC Complete Restart) with your programming device causes the presets to be downloaded from the RLL program, regardless of the state of this dipswitch.

3.4.3 Setting Highest I/O Base Number — TI535 Models

The base assembly holding the PLC also holds the local I/O. The local I/O consists of the first two logical bases, numbered 0 and 1. A logical base is defined as a group of eight I/O slots. As many as fourteen additional logical bases, numbered from 2 to 15, may be connected to the system as distributed I/O.

Switches 5–8 on DIP 1 are used to select the highest-numbered logical base in the system. For example, if your system consists of 5 logical bases numbered 0 through 5, then the dipswitches should be set for 5.

Switches 5–8 reduce I/O update time by preventing the PLC from attempting to communicate with distributed bases that are not present or which you may have shut down. Although it increases scan time, you can set the switches for 15 if you prefer, regardless of the actual number of logical bases that are connected.

You may connect Series 500 bases to your system. Number the Series 500 logical bases just as you would Series 505 bases; however, the total number of logical bases cannot exceed 16.

Figure 3-10 lists the switch positions for each address.

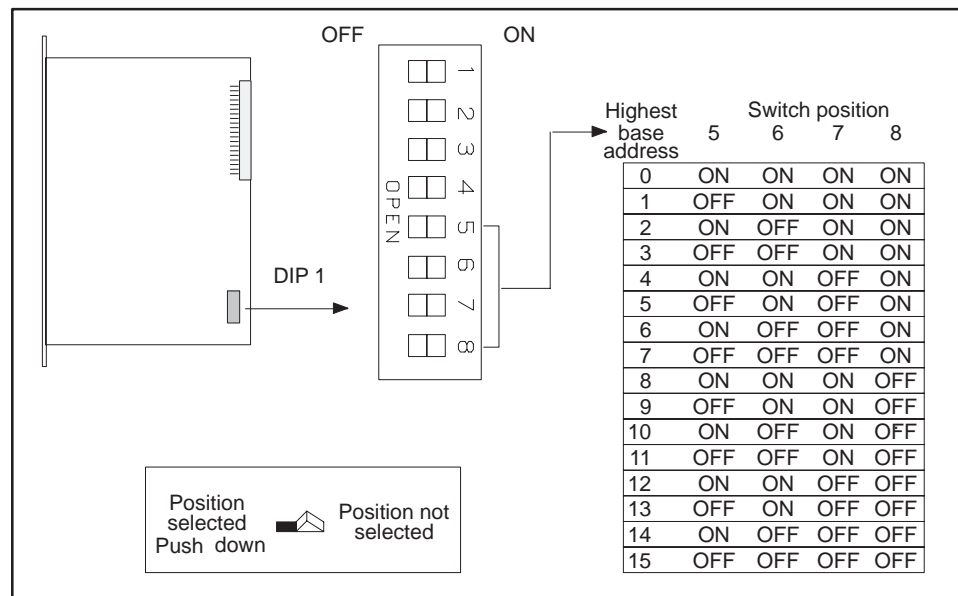

Figure 3-10 Switch Settings — TI535 Highest-Numbered Logical Base

3.4.4 Selecting Battery Backup — TI535 Models

Switch 1 on the second dipswitch assembly (DIP 2) enables or disables the battery backup function. With the battery backup enabled, cycling power does not alter the following information:

- RLL program
- Timer/counter preset and current values
- Drum preset preset and current values
- Word I/O values
- Variable (V) memory values
- Retentive control relay status
- States of forced I/O
- Scan time
- I/O Configuration data

If you power up a TI535 with the battery backup dipswitch turned OFF and have not installed an EPROM/EEPROM, the PLC clears memory.

NOTE

If you are powering up a TI535 for the first time, turn off the battery backup and do not install a programmed EPROM/EEPROM. This ensures that the PLC is properly initialized.

Refer to Figure 3-11. Push Switch 1 LEFT to enable the battery backup. Push switch 1 RIGHT to disable battery backup.

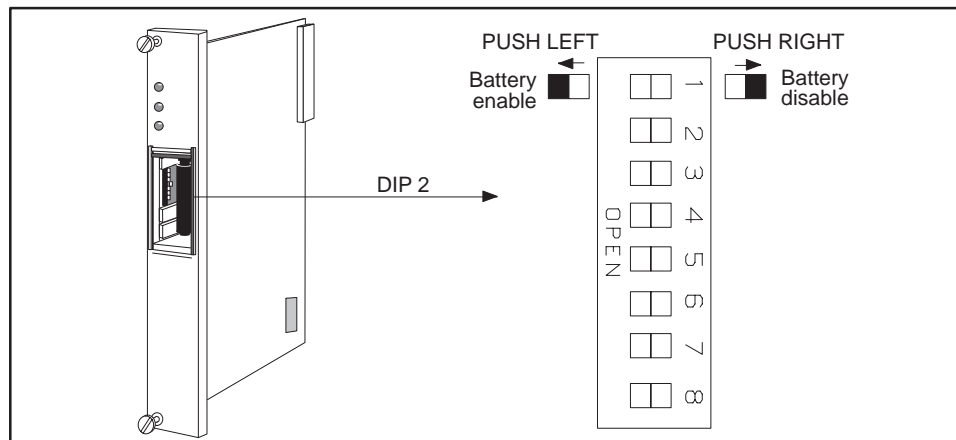

Figure 3-11 Switch Settings — TI535 Battery Backup

INSTALLATION

3.4.5 Setting Communication Port Baud Rate — TI535 Models

Figure 3-12 shows the baud rate switch assignments for the communication ports. Switches 2–4 on the second dipswitch assembly (DIP 2) set the baud rate for the RS-422 9-pin port (Port 2). Switches 5–7 set the baud rate for the RS-232-C/423 25-pin port (Port 1). Switch position does not matter if a device is not to be connected to the port.

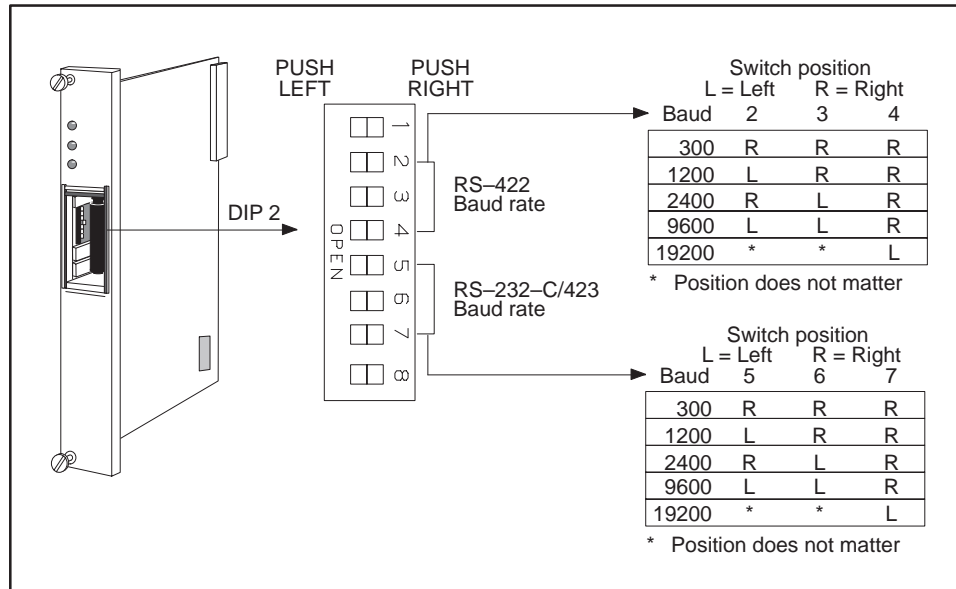

Figure 3-12 Switch Settings — TI535 RS-232-C/RS-423 and RS-422 Ports

INSTALLATION

3.4.6 Selecting Ladder Memory Protection — TI535 Models

Switch 8 on DIP 2 prevents changes to the RLL program in ladder memory. Your programming unit refers to this switch as a keylock.

Refer to Figure 3-13. Push switch 8 LEFT to prohibit changes to the program. Push switch 8 RIGHT to permit program editing.

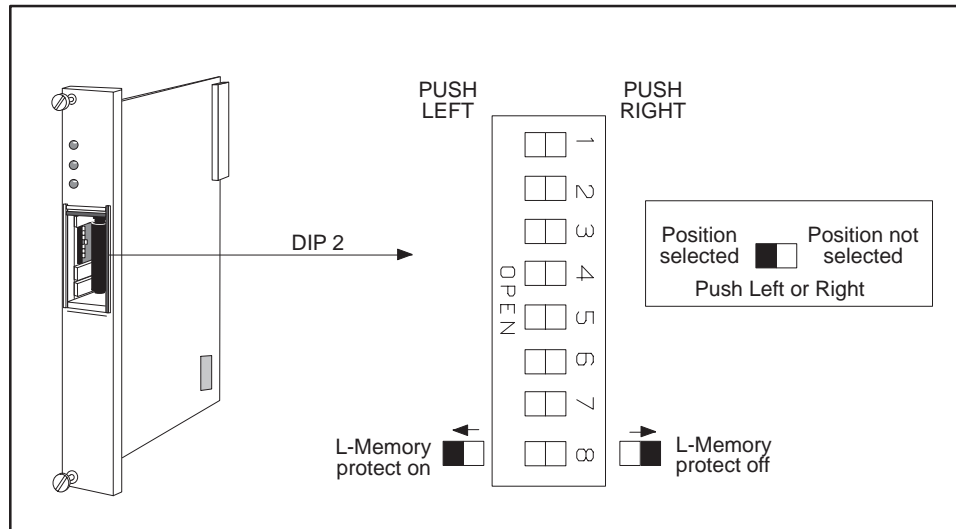

Figure 3-13 Switch Settings — TI535 L-Memory Protection

NOTE

Turning the L-memory protect switch on does not prevent forcing I/O, changing variable memory, or switching the PLC from PROGRAM to RUN mode. These actions may be made by a programming device connected to the PLC, or a special function I/O module designed for this type of interface to the PLC, e.g., a Network Interface Module.

The RLL can also be changed through a special function module, even when the memory protection is enabled with the keylock. Do not depend upon this switch to prevent personnel from interrupting your process.

3.5 INSTALLING THE BATTERY

The TI525/TI535 PLCs are shipped with a lithium battery already installed. This battery has a minimum storage lifetime of three years and a minimum backup lifetime of six months (0° to 60°C). Follow the steps listed below to replace the battery.

3.5.1 Model TI525 Battery Installation

The TI525 is capable of preserving system memory for at least ten minutes after the battery and power have been disconnected. Complete the battery replacement within this period if you wish to save information.

1. **Disable all user-supplied power to the base.**
2. Remove the PLC from the base. Do not touch the components on the printed circuit board or short any etch lines or pins as this may disrupt system memory. Do not place the PLC on a conductive surface.
3. Check the battery backup switch (DIP 2, switch 1). If it is off and you wish to retain system memory, turn the switch on.
4. Remove the battery from the clip and disconnect the leads.
5. The new battery should be a 3.0 VDC UL Recognized lithium battery (PPX:2587678-8005). Connect the red wire to the positive pole and the black wire to the negative pole of the new battery. Then insert the new battery into the battery holder.
6. Insert the PLC into the base, enable power, and verify that the BATT GOOD LED comes on.

INSTALLATION

3.5.2 Model TI535 Battery Installation

Take the following steps to replace the battery.

1. **Ensure that the power to the PLC is on. Replacing the battery with power off will result in memory loss.**
2. Open the battery door as shown in Figure 3-14.

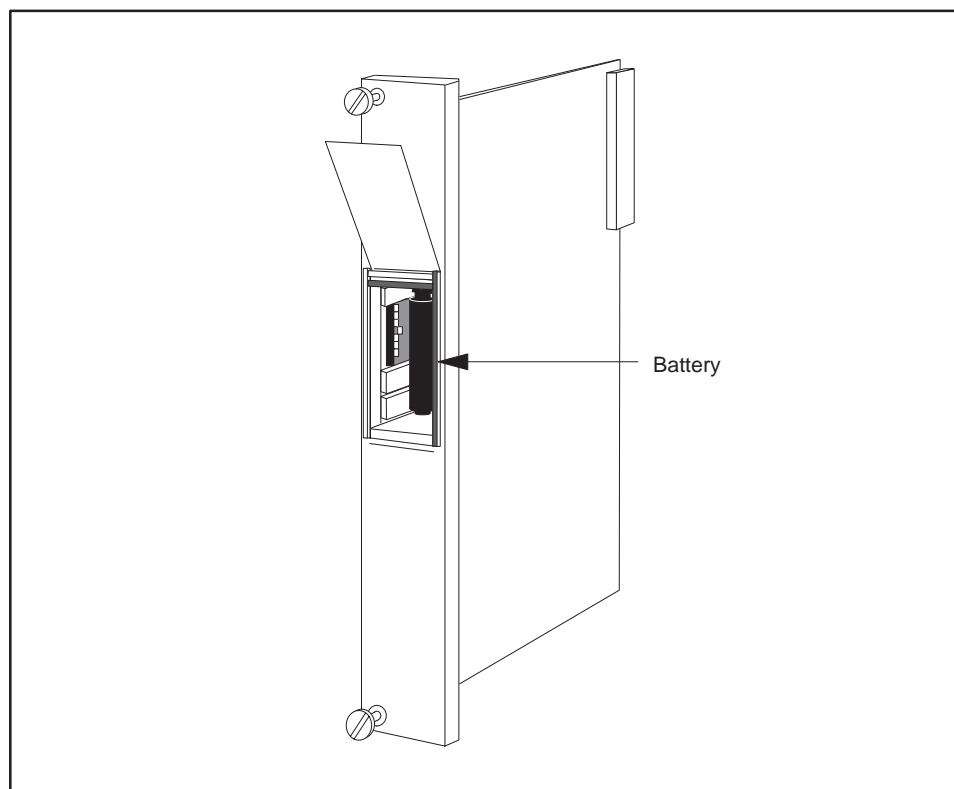

Figure 3-14 Battery Location for TI535 Models

3. Remove the battery from the compartment and disconnect the leads.
4. Attach the leads to the new battery (3.0 VDC UL Recognized lithium battery (PPX:2587678-8005). Connect the red wire to the positive pole and the black wire to the negative pole. Push the new battery and leads back into the compartment.
5. Set the battery dipswitch ON (DIP 2, switch 1) if you wish to enable battery backup. The BATT GOOD indicator should light.
6. Close the battery door.

3.6 INSTALLING SYSTEM COMPONENTS

A base assembly is composed of one or two logical bases. A logical base is defined as a group of eight I/O slots, as shown in Figure 3-15. Therefore, the PPX:505-6516 sixteen-slot base assembly comprises two logical bases, while the PPX:505-6508 eight-slot base assembly contains one logical base. The four-slot PPX:505-6504 base also contains one logical base, but slots 5-8 do not physically exist. A system may consist of as many as 16 logical bases and up to 1023 I/O points.

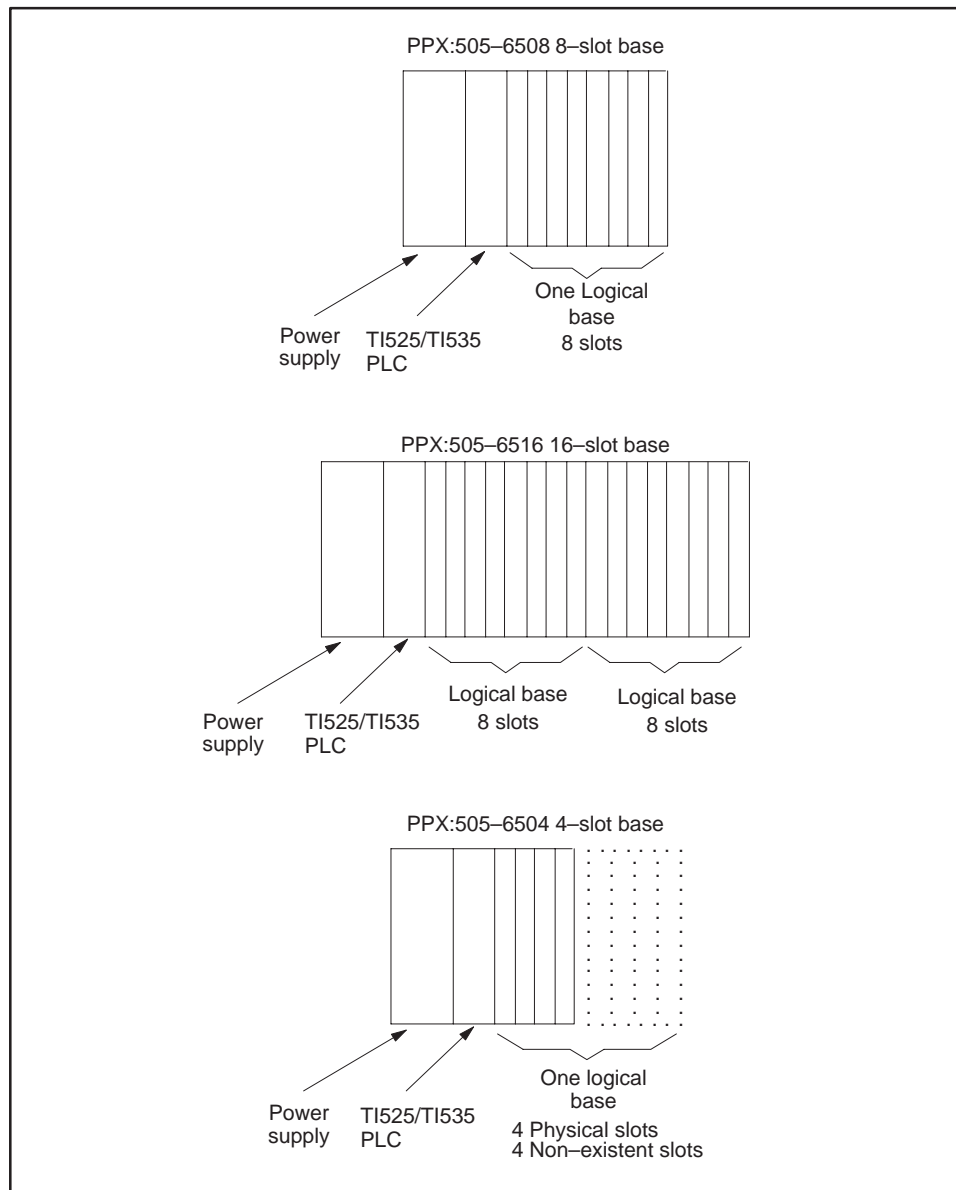

Figure 3-15 Definition of the Series 505 Logical Base

INSTALLATION

I/O modules are grouped into local or distributed I/O categories depending upon their physical location. The local I/O comprises those modules installed in the same base assembly as the PLC — the primary base.

A system having local I/O only consists of a single base assembly comprising a maximum of two logical bases. A 16-slot base assembly contains two logical bases, numbered 0 and 1 from left to right. The 8-slot and 4-slot base assemblies each contain one logical base, numbered 0. See Figure 3-16.

NOTE

Bases 0 and 1 are always on the local base. Therefore, any distributed base will always be numbered greater than 1.

If your system has local I/O only, you need to install the power supply, PLC and I/O modules in a single base assembly. See the installation instructions later in this chapter.

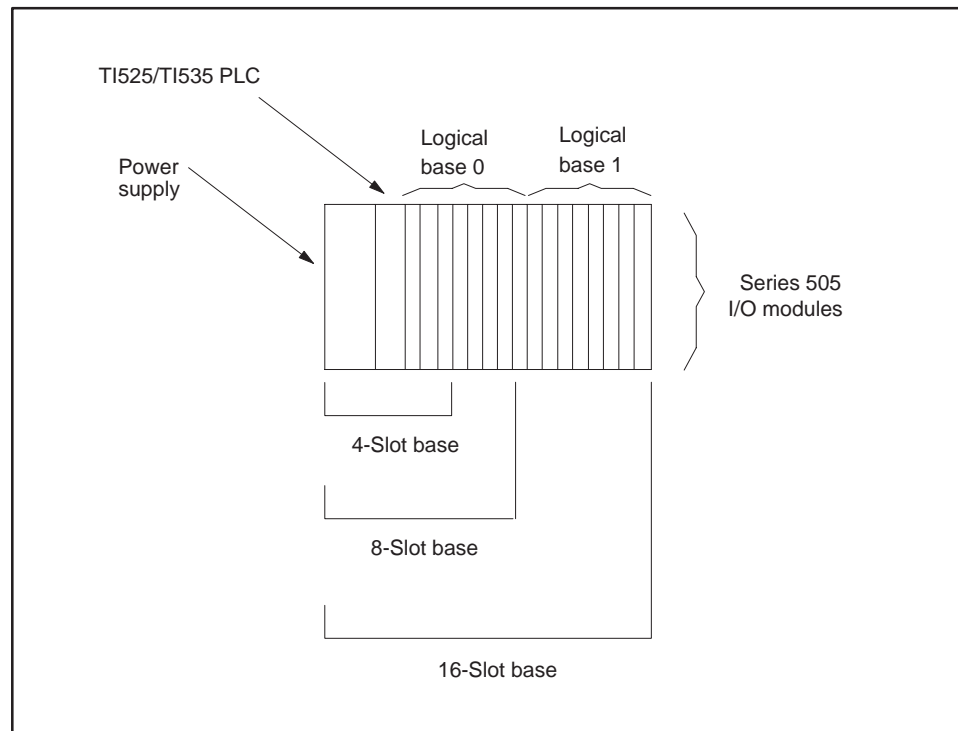

Figure 3-16 System With Local I/O Only

INSTALLATION

You may connect up to 14 additional base assemblies to your system, as shown in Figure 3-17. These additional bases constitute the distributed I/O and are numbered from 2 to 15.

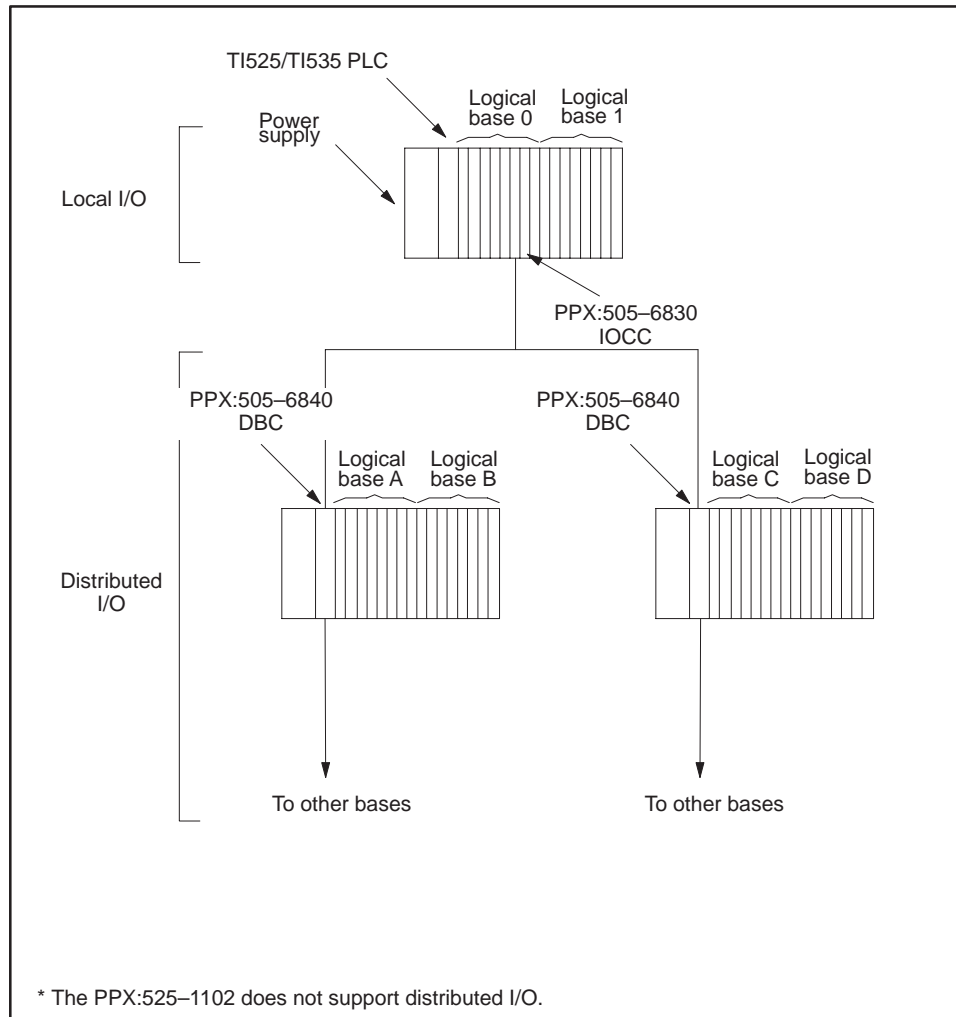

Figure 3-17 Systems with Local and Distributed I/O

The I/O modules in the distributed bases communicate with the PLC through base controllers. The Series 505 Distributed Base Controller (DBC) (PPX:505-6840) in each distributed base assembly transmits all information from the I/O modules in that base assembly to the I/O Channel Controller (IOCC) (PPX:505-6830).

A system with distributed I/O requires one IOCC, located in the primary base. Depending upon the cable used, the line drivers of the DBC and the IOCC permit distributed I/O to be up to 1300 feet (396 m) from the PLC.

Both Series 500 and 505 I/O can be connected to a TI525/TI535 PLC as distributed I/O. The Series 505 IOCC (PPX:505-6830) is capable of addressing the Series 500 DBCs (PPX:2109 or PPX:505-2103) in a Series 500 base assembly.

If your application requires distributed I/O, you must install an IOCC in the primary base assembly. You must also install the distributed bases with their power supplies, DBCs, I/O modules, and cabling. See the installation instructions later in this chapter.

3.6.1 Numbering Series 505 I/O Points

When you configure the I/O, you assign an I/O point number to each point. You do this from the I/O Module Definition Chart on your programming device.

Local I/O consisting of a maximum of 512* I/O points can be configured when you assign the I/O point numbers. This is obtained by using base Model 505-6516 (sixteen slots) and 32-point I/O modules.

The PLC permits a maximum number of 1023 points for a local and distributed system. You need not assign the point numbers consecutively. For example, in a distributed system, Base 2 can be assigned I/O point numbers 897-960. However, the highest point number that you can assign to a point is 1023.

You do not need to assign I/O point numbers to empty slots or to non-existent slots in logical bases having fewer than eight slots.

* I/O Module power consumption requirements may reduce the actual number of I/O points that can be installed.

3.6.2 Guidelines For Installing Series 505 Modules

The Series 505 I/O, base controllers, and PLCs are all open-card modules in double Eurocard design*. The power supply is a partially encased module in double Eurocard design. Follow the guidelines in the following paragraphs when inserting or removing the modules.

WARNING

Do not insert or remove modules while power is enabled to the PLC. Modules may be damaged if inserted while power is on, and memory may be lost if the PLC is removed while power is on.

* System 505 components are compatible with International standards double–Eurocard (DIN standard 41494)

INSTALLATION

Complete the following steps to insert the modules into the base.

1. **Disable all user-supplied power before inserting modules.**
2. Holding the module by the bezel, position the printed circuit board in the upper and lower card guides.
3. Insert the module and push until it is plugged into the backplane connector. The bezel should be tight against the base.
4. The bezel screws provide the ground. Use a flat-blade screwdriver to tighten the screws at the top and the bottom of the bezel. Do not over-tighten. The maximum torque that can be applied to the screw is 3 Kg f -cm (2.60 in-lb).

NOTE

For instructions on wiring I/O modules and calculating I/O power requirements, check the appropriate manual for each I/O module.

Complete the following steps to remove the modules into the base.

1. **Disable line and user-supplied power.**
2. Loosen the screws at the top and bottom of the bezel.

NOTE

Prior to removing I/O modules, you may remove the wiring terminal block without disturbing field wiring. Use a Phillips-head screwdriver to remove the screws at the top and bottom of the terminal block and pull the terminal block off the bezel.

3. Grasp the bezel screws and carefully remove the module. You may find it easier to loosen the module first by gently pulling the module up and down within the slot by the bezel screws.

INSTALLATION

3.6.3 Installing the Power Supply

You may operate the PPX:505–6660 or PPX:505–6660A power supply at either 110 or 220 VAC. **The power supply is shipped preset for 220 VAC.** Use the jumper shown in Figure 3-18 to select the proper voltage for your application.

CAUTION

To minimize the risk of personal injury, disable all system power before changing the power supply jumper. Attempts to operate the power supply with the line voltage jumper placed incorrectly may damage the power supply.

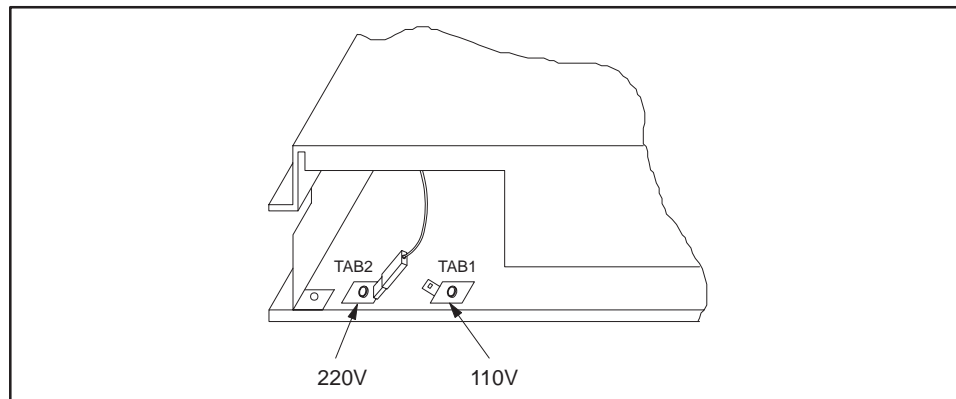

Figure 3-18 Power Supply Jumper

Follow the steps listed below to install the power supply.

1. Remove the strip of paper covering the wire connectors on the terminal block.
2. Select the proper operating voltage by placing the jumper on the appropriate quick-connect as shown in Figure 3-18. (Not required for the PPX:505–6663 power supply.)
3. **Disable all user-supplied power to the base.**
4. Insert the power supply into the far left slot of the base as shown in Figure 3-19.
5. Tighten the bezel screws.

INSTALLATION

6. Use 14 AWG solid or stranded wire for connection to the power source; use of smaller wire is not recommended. If stranded wire is used, the wire should be twisted and tinned.
7. Insert the green ground wire into the connector labeled “ground.”
8. Insert the black AC line and white AC neutral wires into the power supply wire connectors labeled “AC line” and “AC neutral,” respectively.

WARNING

Connecting the power supply leads to the wrong terminals creates a potential shock hazard that could cause damage to equipment or injury to personnel. Be sure that the polarity on all power supply leads is correct.

9. After inserting the wires, secure them by tightening the terminal block screws.
10. Enable power.

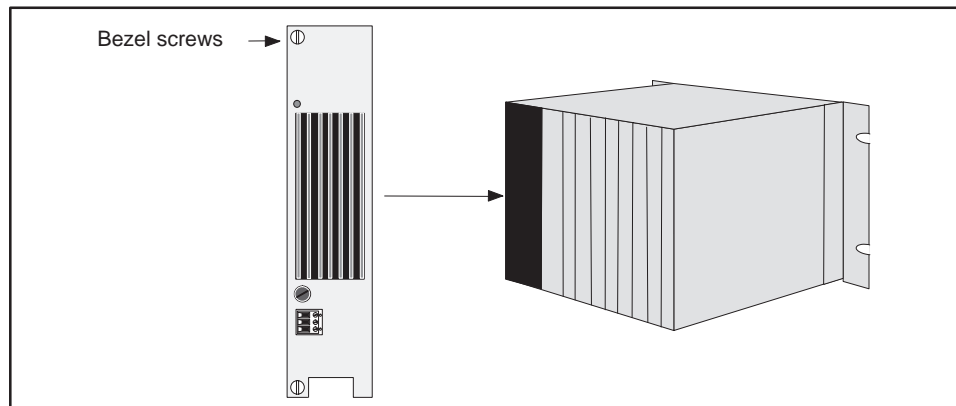

Figure 3-19 Location of Power Supply in Base

The base power budget is determined from the power provided by the base power supply and the requirements of the particular modules used. When determining the I/O system layout, do not exceed the maximum power available from the power supply. The total power requirement for all modules drawing power from a Series 505 base must be less than or equal: 55 W at +5 VDC and 3.75 W at -5 VDC.

3.6.4 Installing the PLC

Complete the following steps to install the PLC in the base.

1. Check dipswitches for correct configuration.
2. **Disable all user-supplied power to the base.**
3. Insert the PLC into its slot adjacent to the power supply as shown in Figure 3-20.
4. Tighten the bezel screws.

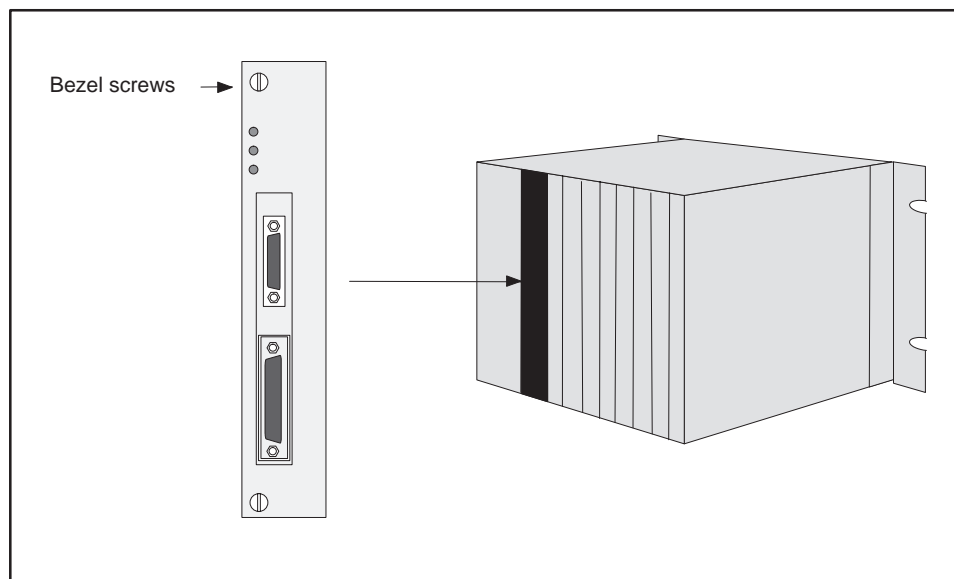

Figure 3-20 Location of PLC in Base

5. If you have equipment to connect to the ports, attach the communication cables to the appropriate port(s). The RS-232-C/RS-423 compatible port accepts a 25-pin male plug and allows communication with equipment up to 50 ft (15.2 m) away. The RS-422 compatible port accepts a 9-pin male plug and allows communication up to a distance of 1000 ft (305 m) for all baud rates supported by the PLC model. Both ports are configured as Data Terminal Equipment (DTE). The pin-outs are listed in Table 3-1.

NOTE

If you are powering up a TI535 for the first time, turn off the battery backup. This ensures that the TI535 PLC is properly initialized. Refer to the startup procedure in Chapter 5.

6. Enable power.

Table 3-1 Pin-out for the RS-232-C/RS-423 Port

RS-232-C/423 Port		RS-422 Port	
Pin	Signal	Pin	Signal
2	Transmitted data	1	Data out
3	Received data	5	Data in
4	Request to send	6	Ground
5	Clear to send	7	Data out, inverted
6	Data set ready	8	Data in, inverted
7	Signal ground		
8	Received line signal detector		
20	Data terminal ready		
	All others—no connection		All others—no connection

3.6.5 Installing the I/O Modules

The wiring for the different I/O module terminal blocks may vary. You should read the user's manual for an individual module before wiring and installing the module. Insert the I/O modules into the base, starting with the slot adjacent to the PLC as shown in Figure 3-21.

CAUTION

Use supply wires suitable for at least 75°C. Signal wiring connected in this box must be rated at least 300 V.

ATTENTION

Employer des fils d'alimentation pour au moins 75°C. Le câblage de signalisation raccorde dans cette boîte doit convenir pour une tension nominale d'au moins 300 V.

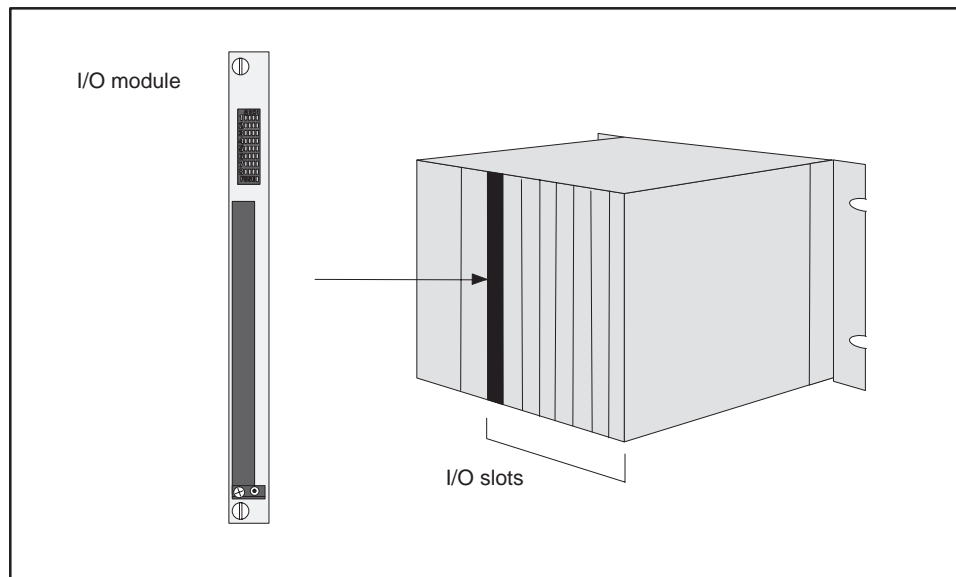

Figure 3-21 Location of I/O Modules in Base

The base power budget is determined from the power provided by the base power supply and the requirements of the particular modules used. When determining the I/O system layout, take care not to exceed the maximum power available from the power supply.

The total power requirement for all modules drawing power from a Series 505 base must be less than or equal: 55 W at +5 VDC and 3.75 W at -5 VDC.

NOTE

Do not install more than four word modules in a physical base. This may cause a DC loading problem in the PLC which could result in unexpected disabling of output modules (including discrete output modules). For example, even though a 16-slot base contains two logical bases, you can only have a total of four modules.

Appendix C gives the power requirements for many of the currently available Series 505 and Series 500 modules. For other modules not listed see the manual for that module.

All the TI525 and TI535 controllers use the Series 505 I/O modules. These I/O modules have different numbers and types of I/O points. For example, an eight-point discrete input requires eight inputs (Xs) be assigned, while an eight-point analog output module requires assignment of eight word outputs (WYs). Table 3-2 lists the number and type of points required to log in the Series 505 I/O modules. Additional information on particular modules is given in the manual included with each module.

INSTALLATION

Table 3-2 I/O Module Point Assignments
(Continued on next page)

Model Number	Model Description	Points Used	Special Function	Slots Used
PPX:505-4008	20-56 VAC Input	8X		1
PPX:505-4016	20-56 VAC Input	16X		1
PPX:505-4032	20-56 VAC Input	32X		1
PPX:505-4108	4.5-15 VDC Input	8X		1
PPX:505-4116	4.5-15 VDC Input	16X		1
PPX:505-4132	4.5-15 VDC Input	32X		1
PPX:505-4208	79-132 VAC Input	8X		1
PPX:505-4216	79-132 VAC Input	16X		1
PPX:505-4232	79-132 VAC Input	32X		1
PPX:505-4308	14-32 VDC Input	8X		1
PPX:505-4316	14-32 VDC Input	16X		1
PPX:505-4317	16 Isolated Inputs or 8 Interrupt Inputs/8 Isolated Inputs	16X		1
PPX:505-4332	14-32 VDC Input	32X		1
PPX:505-4408	164-256 VDC Input	8X		2
PPX:505-4416	164-256 VDC Input	16X		1
PPX:505-4432	164-256 VDC Input	32X		1
PPX:505-4508	4.5-34 VDC, 0.5 Amp Output	8Y		1
PPX:505-4516	4.5-34 VDC, 0.5 Amp Output	16Y		1
PPX:505-4532	4.5-34 VDC, 0.5 Amp Output	32Y		1
PPX:505-4608	20-132 VAC, 0.5 Amp Output	8Y		1
PPX:505-4616	20-132 VAC, 0.5 Amp Output	16Y		1
PPX:505-4632	20-132 VAC, 0.5 Amp Output	32Y		1
PPX:505-4708	4.5-34 VDC, 2.0 Amp Output	8Y		2
PPX:505-4716	4.5-34 VDC, 2.0 Amp Output	16Y		2
PPX:505-4732	4.5-34 VDC, 2.0 Amp Output	32Y		2
PPX:505-4808	85-256 VAC, 2.0 Amp Output	8Y		2
PPX:505-4816	85-256 VAC, 2.0 Amp Output	16Y		2
PPX:505-4832	85-256 VAC, 2.0 Amp Output	32Y		2
PPX:505-4908	20-256 VAC or 4.5-34 VDC Form C Output	8Y		1
PPX:505-4916	20-256 VAC or 4.5-34 VDC Normally Open Output	16Y		1
PPX:505-4932	20-256 VAC or 4.5-34 VDC Normally Open Output	32Y		2
PPX:505-5417	115 VDC, Relay Output	16Y		1

Table 3-2 I/O Module Point Assignments
(Continued)

Slots	Model Number	Model Description	Used	Points Function	Special Used
	PPX:505-6010	32-Point Input Simulator	32X		1
	PPX:505-6011	32-Point Output Simulator	32Y		1
	PPX:505-6108	8-Channel Analog Input	8WX		2
	PPX:505-6108A	8-Channel Analog Input	8WX		1
	PPX:505-6202	2-Channel Analog Output	2WY		2
	PPX:505-6204	4-Channel Analog Output	4WY		2
	PPX:505-6208	8-Channel Analog Output	8WY		2
	PPX:505-6208A	8-Channel Analog Output	8WY		1
	PPX:505-6308	8-Channel Word Input	8WX		2
	PPX:505-6408	8-Channel Word Output	8WY		2
	PPX:505-7012	8 In/4 Out Analog	12WX & 4WY or 4WX & 4WY or 6WX & 2WY or 8WX		1
	PPX:505-7016	Bipolar 8 In/4 Out Analog	12WX & 4WY or 20WX & 4WY or 4WX & 4WY or 8WX		1
	PPX:505-7028	Thermocouple Input	8WX		1
	PPX:505-7038	RTD Input	8WX or 16WX		1
	PPX:505-7101	BASIC Module	4WX & 4WY	✓	1
	PPX:505-7339	TIWAY Network Interface Module Local Line Ports	8WY	✓	1
	PPX:505-7340	TIWAY Network Interface Module RS-232-C/423 Ports	8WY	✓	1
	PPX:505-7354	Peerlink	3WX & 5WY	✓	1

3.6.6 Installing the Base Controllers

Refer to the *Series 500/505 IOCC and DBC User's Manual* (PPX:500-8143) for instructions on wiring and installing the IOCC (PPX:505-6830) and the DBC (PPX:505-6840).

NOTE

The DBCs are multi-dropped from the IOCC. If one distributed base becomes disabled, all the remaining DBCs should continue to communicate with the PLC.

CHAPTER 4

EPROM/EEPROM OPERATION

4.1 INTRODUCTION

The TI525/TI535 controllers offer the option of saving the RLL program to an Electrically Erasable Programmable Read Only Memory (EEPROM) without the use of a separate programming device. The RLL program is downloaded directly from the PLC RAM to a 256 kbyte EEPROM (PPX:2587681–8020).

NOTE

The EEPROM holds only the ladder logic program and the I/O configuration. Other information stored in memory is cleared if power is cycled without a battery backup.

Once an EEPROM is programmed, you may use it in any of the TI525/TI535 or TI530T models. The only limitation is program size. The PLC must have enough memory to store and execute the program contained on the EEPROM. You can erase an EEPROM with a programming device that is capable of executing Auxiliary (AUX) Function 84. A TI525/TI535 EEPROM cannot be used in SIMATIC® TI520™, SIMATIC® TI530™, SIMATIC® TI520C™, or SIMATIC® TI530C™ models.

If you choose, you may program an EPROM in a TI520C or TI530C and use the EPROM in any of the TI525/535 PLCs. The PLC must have the memory capacity to execute the program. Although they do not copy a program to an EPROM, all TI525/TI535 models can read and execute an EPROM program with which they are compatible. You may also save a program to the EEPROM and then use an EPROM programmer to copy the program from EEPROM to EPROM.

To ensure equipment compatibility use only the EPROM model supplied by your distributor: (PPX:2587681–8012).

WARNING

The older non-compiled TI520/TI530 EPROMs are not compatible with any other Series 500 or Series 505 PLCs. Attempting to interchange the EPROMs may cause injury to personnel or damage to equipment because of unexpected operation of the PLC.

When you power up a TI525/TI535, the PLC checks the status of the EPROM/EEPROM and the battery. A “clear” (unprogrammed) EPROM/EEPROM is equivalent to there being no EPROM/EEPROM installed. Table 4-1 lists the effects on memory and the mode that the PLC enters after power up.

EPROM/EEPROM OPERATION

Table 4-1 Changes in Mode and Memory After Power Up

Conditions		Results		
Battery Status	Programmed EPROM or EEPROM Present	System Memory		PLC Mode
Bad	No	Cleared		PROGRAM
Bad	Yes	Cleared		RUN PLC executes program in EPROM/EEPROM
Good	No	No Change		No Change
Good	Yes	No Change		No Change
Disabled for 10+ minutes while power to the PLC is off.	Yes	Cleared		RUN PLC executes program in EPROM/EEPROM
	No	525	Cleared	PROGRAM
		535	No Checksum Errors Found: No Change	No Checksum Errors Found: No Change
			Checksum Errors Found: Cleared	Checksum Errors Found: PROGRAM

4.2 INSTALLING AN EPROM/EEPROM IN TI525 MODELS

Before beginning installation, you must disable power to the PLC. If you intend to download a program in RAM memory to an EEPROM, you should ensure that a good battery is installed and enabled, or the program may be lost when power is restored. Follow the steps listed below.

1. Place the PLC in PROGRAM MODE.

NOTE

The PLC mode (RUN or PROGRAM) on power-up depends upon mode at power-down, the condition of the battery, and the presence or absence of an EPROM/EEPROM. Refer to Table 4-1.

2. **Turn off all user-supplied power to the PLC base.**
3. Remove the PLC from the base assembly.
4. Ensure that switch 1 on the second dipswitch (DIP 2) is turned ON. This enables battery backup.

NOTE

If the battery backup is disabled and you take longer than 10 minutes to install the EPROM/EEPROM, you may lose the program stored in RAM.

5. Refer to Figure 4-1. If you are installing an EPROM, place jumpers on pins 2–3 and 4–5. If you are installing an EEPROM, place jumpers on pins 1–2 and 3–4.
6. Insert the EPROM/EEPROM, aligning the notches on the EPROM/EEPROM and the socket.
7. Check the pins to make sure that they are all seated properly in the socket.

EPROM/EEPROM OPERATION

- Place the PLC in the base and enable power. Refer to the Troubleshooting Chapter if the EPROM/EEPROM fails to function correctly.

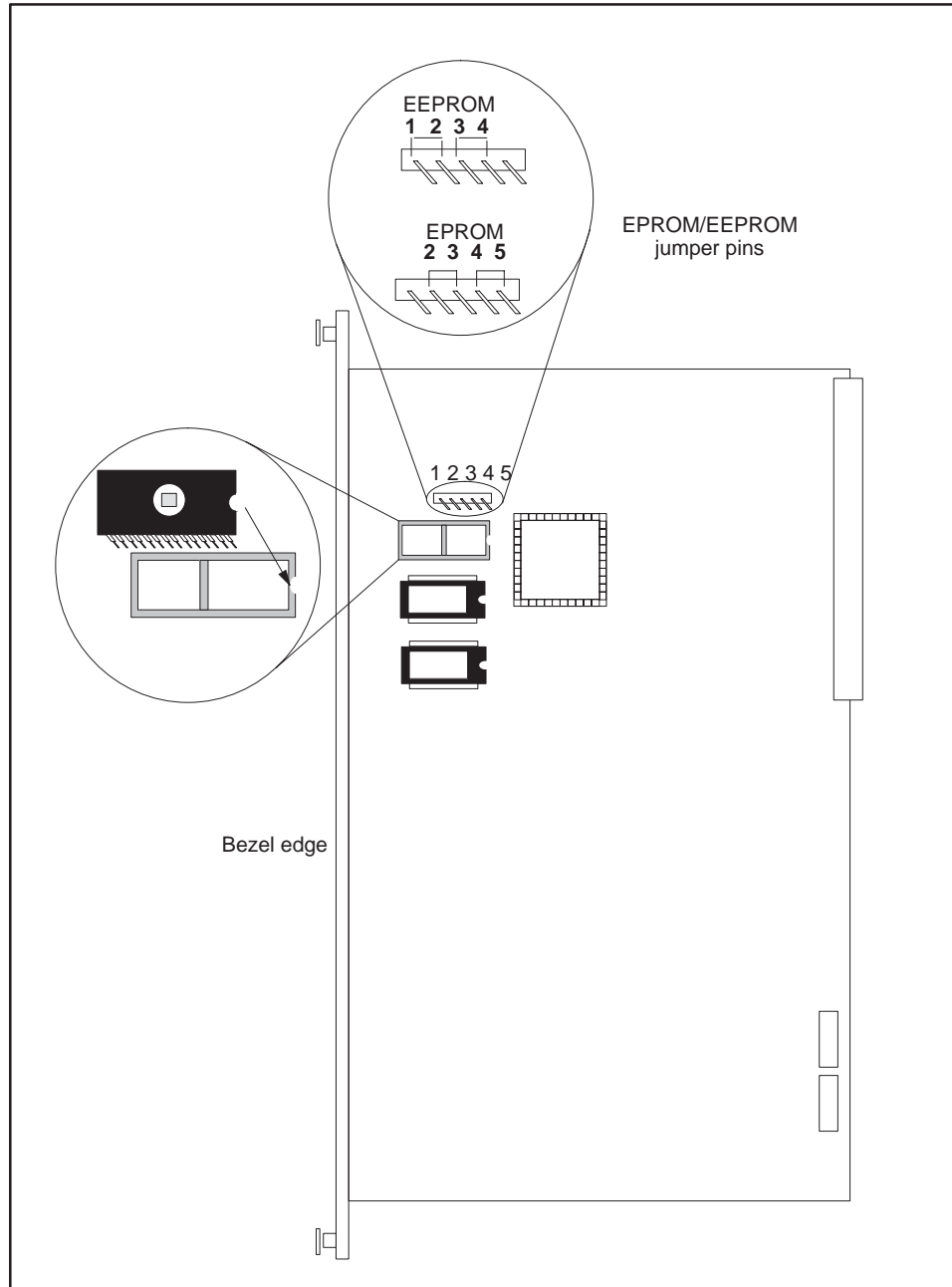

Figure 4-1 TI525 EPROM/EEPROM Socket and Jumper Pins

4.3 INSTALLING AN EPROM/EEPROM IN TI535 MODELS

If you are powering up a TI535 for the first time you should initialize it before proceeding with the EPROM/EEPROM installation. Refer to the startup procedure in Chapter 5.

To install the EPROM/EEPROM, follow these steps.

1. Using the programming unit, place the PLC in PROGRAM MODE.

NOTE

The PLC mode (RUN or PROGRAM) on power-up depends upon mode at power-down, the condition of the battery, and the presence or absence of an EPROM/EEPROM. Refer to Table 4-1.

2. Ensure that the Battery Good LED is on. If it is not, turn on switch 1 on DIP 2. This enables battery backup. If the Battery Good LED remains off, replace the battery before continuing with the EPROM/EEPROM installation.

NOTE

If you power down the TI535 while the BATT GOOD LED is off, you may lose the program stored in RAM.

3. **Turn off all user-supplied power to the PLC base.**
4. Remove the PLC from the base.
5. If you are installing an EPROM, place jumpers on pins 2–3 and 4–5. If you are installing an EEPROM, place jumpers on pins 1–2 and 3–4. Refer to Figure 4-2.
6. The EPROM/EEPROM socket is a zero insertion force socket, and no pressure is required to insert the 28-pin EPROM/EEPROM. Use a small, flat-blade screwdriver to open the socket. Turn the screw on the socket counterclockwise one quarter turn until the socket pins have opened.

EPROM/EEPROM OPERATION

7. Insert the EPROM/EEPROM, aligning the notch on the EPROM/EEPROM with the socket screw. Refer to Figure 4-2.
8. Check the pins to make sure that they are all seated properly. Tighten the socket by turning the screw clockwise.
9. Replace the PLC in its base and enable power. Refer to the Troubleshooting Chapter if the EPROM/EEPROM fails to function correctly.

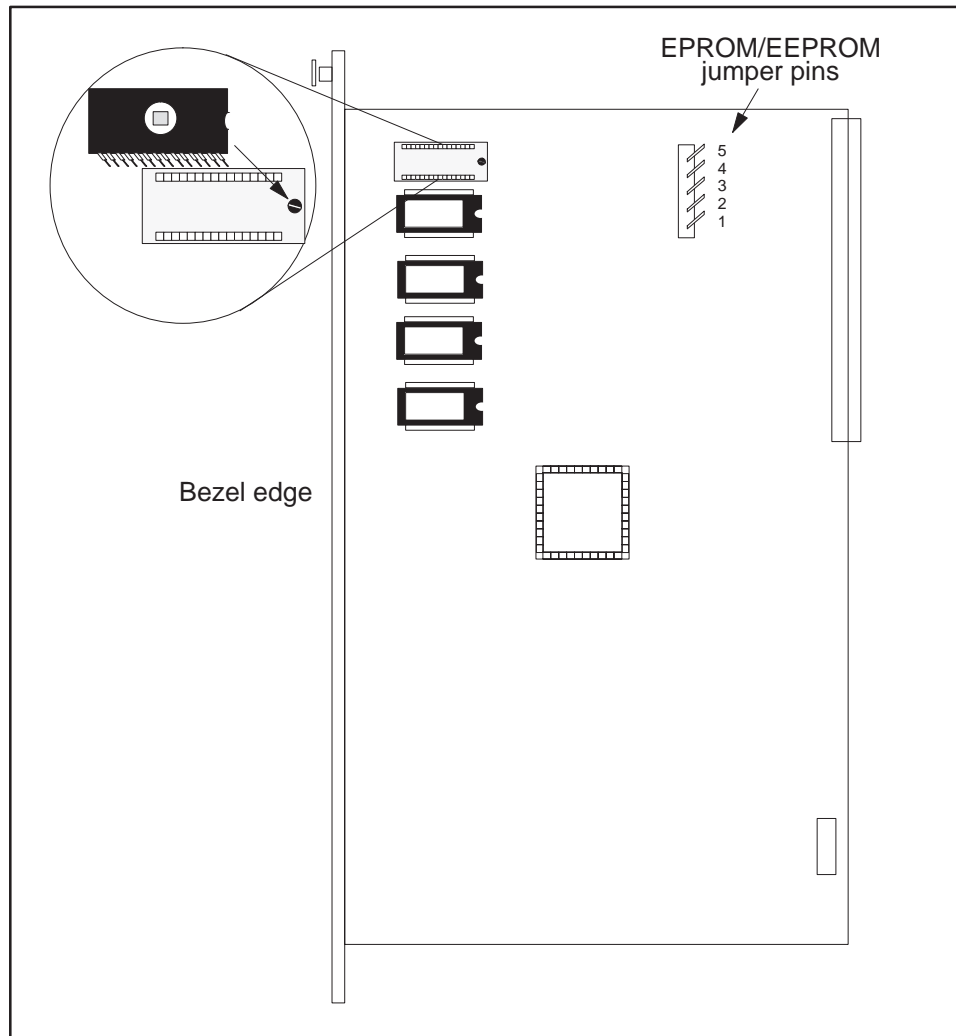

Figure 4-2 TI535 EPROM/EEPROM Socket and Jumper Pins

4.4 PROGRAMMING THE EEPROM

To program the EEPROM, you first must enter the RLL program into the PLC. Verify that this program is correct and continue with the steps listed below.

1. Make certain that the battery enable dipswitch is ON, and that the jumper pins are set for EEPROM.
2. Set the PLC to PROGRAM mode.
3. Select Auxiliary Function 84 in your programming unit. Use the “Copy” option to copy your RLL program to the EEPROM. The programming unit displays messages indicating the progress of the copy operation.

The PLC completes all current and pending communication processes and turns off the communication ports before beginning the copy operation.

NOTE

The TI525/TI535 PLCs copy data to the EEPROM very rapidly. The entire copy process takes approximately 5 seconds or less.

The PLC enters PROGRAM mode when the copy process is completed.

4. When you are finished making copies of your program, go to step 5.

If you wish to copy the program to another EEPROM, power down the PLC, replace the EEPROM with another, and power up again. Repeat Step 3 to copy the program to this second EEPROM. This procedure can be repeated to program several EEPROMs.

5. Check the program carefully, while the PLC is in the PROGRAM mode, before allowing the PLC to control equipment connected to the I/O.

WARNING

Do not place the PLC in RUN mode without first verifying the EPROM/EEPROM program. If the program is incorrect, unexpected operation by the PLC may result in injury to personnel and/or damage to equipment.

Any errors that occur during the copy process are listed on the programming unit. Check the EPROM/EEPROM jumper pins and make certain that an EEPROM, not an EPROM, is installed. Make certain that all IC pins are properly seated in the socket.

If you continue to get copy errors, then the EEPROM may have failed. You must power down, remove the EEPROM, and power up again to clear this error condition.

4.5 REPORTING EEPROM STATUS

EEPROM programming information is recorded in status words that can be read with the programming device. These status words represent EEPROM programming information gathered on the last completed programming cycle. They can be read any time except when you are in the process of programming.

If an error occurs while you are copying a program to an EEPROM, you can examine the status words to evaluate the error condition. Follow the steps below:

1. Make certain that the battery is enabled.
2. Clear the error condition by cycling power.
3. Examine the status words with a programming unit.

4.5.1 Status Word Six (STW06)

As illustrated in Figure 4-3 below, STW06 reports the status of EEPROM programming.

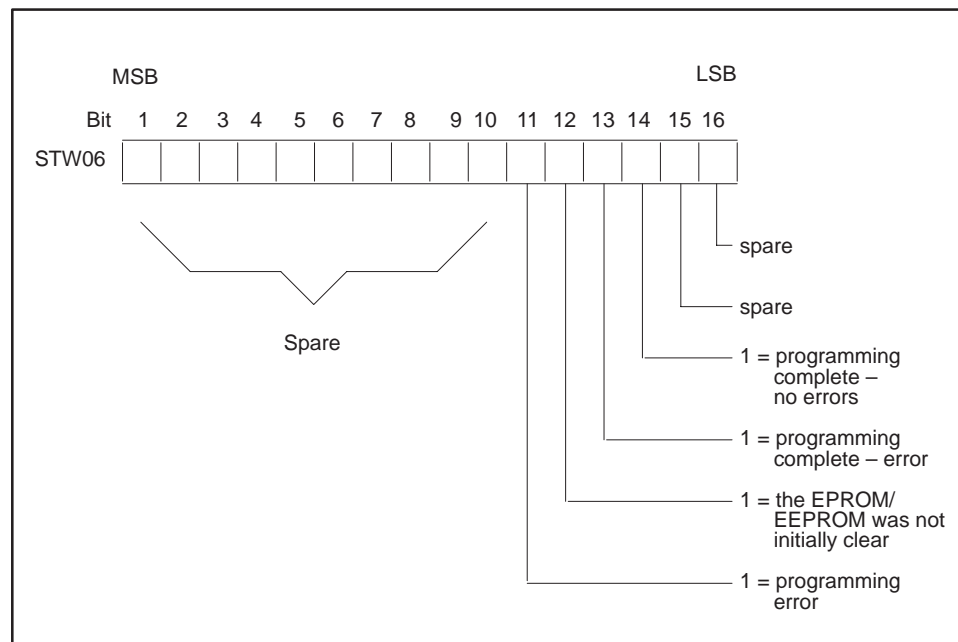

Figure 4-3 Format of Status Word Six (STW06)

4.5.2 Status Words Seven to Nine (STW07–STW09)

STW07 gives the absolute address of the first error encountered while attempting to program the EEPROM. The value given is the memory address of the EEPROM memory.

STW08 shows the checksum calculated from the RLL program stored in the EEPROM. The checksum is a numerical calculation based on your RLL program only. When you copy a program to several EEPROMs, you can check STW08 for every EEPROM to verify that the information contained in each is identical.

NOTE

Identical RLL programs and identical I/O configurations programmed in different machines may yield different checksums due to internal storage differences.

STW09 shows the checksum generated from the EEPROM. The checksum is a numerical calculation based on all data stored in the EEPROM, including your RLL program and information contained in the I/O configuration memory. When you copy a program to several EEPROMs, you can check STW09 for each EEPROM to verify that the information contained in each is identical.

WARNING

Permitting a PLC to execute an EPROM/EEPROM program without first checking the program may result in injury to personnel and damage to equipment due to unexpected operation by the PLC. If you are not absolutely certain that the EPROM/EEPROM program is correct, disconnect all I/O modules and the IOCC (if necessary) from the base before you power up.

4.6 EDITING/SAVING PROGRAMS USING AN EPROM/EEPROM

You manage operation of the EPROM/EEPROM by executing AUX Function 84 on the programming unit. Function 84 gives you the following options:

- Copy RAM to EEPROM
- Copy EEPROM to RAM
- Select RAM as program source
- Select EEPROM as program source
- Erase program in EEPROM
- Report source (RAM OR EEPROM) of program being executed

NOTE

If you use an EPROM in a TI525/TI535, you cannot execute these AUX Function 84 options:

Copy RAM to EEPROM
Erase program in EEPROM

The EEPROM is automatically write protected on power-up, which prevents any accidental write operations. This protective measure does not hinder the device operation in any way. If you want to use the device in equipment other than SIMATIC TI equipment, you can deactivate this protective feature by erasing the EEPROM, powering down the unit, and removing the EEPROM.

EPROM/EEPROM OPERATION

You can edit an RLL program in an EEPROM by following the steps listed below. Refer to the user's manual for your programming unit for detailed instructions about the execution of AUX Functions.

1. Execute the AUX Function 84 option that copies EEPROM to RAM.
2. Select RAM as the program source.
3. Make changes in your program with a programming unit by editing the source code in RAM memory.
4. Execute the AUX Function 84 option that copies RAM to EEPROM.
5. Select the EEPROM as the program source.

Although the TI525/TI535 can copy a program from either an EPROM or an EEPROM into RAM, the TI525/TI535 cannot copy a program from RAM to an EPROM.

NOTE

AUX Function 84 affects only the RLL program and the I/O configuration. Timer/counter and drum/event drum variables and values in V memory are not affected by AUX Function 84 operations.

CHAPTER 5

STARTUP / TROUBLESHOOTING

5.1 START-UP PROCEDURES

Follow the steps outlined below before powering up your TI525/TI535 system for the first time.

1. Be familiar with the operation of the system components as discussed in this installation manual.
2. Verify the following items:
 - If any of your installed bases have empty I/O slots, use filler bezels (PPX:2587705–8003) to cover the openings in the base. This prevents debris from interfering with system operation and helps to guard against electrostatic discharge and electrical noise interference.
 - After installation is complete, remove the plastic dustguard on the top grill of every installed Series 505 base.

WARNING

Failure to remove the dustguard may result in overheating and damage to equipment, and could result in injury to personnel.

- Check for correct switch settings on all configurable modules, e.g., the PLC and DBC(s). The L-memory MEMORY PROTECT dipswitch on the PLC must be OFF if you intend to enter the RLL program with a programming device.
- All modules are securely plugged into the base, connector pins are not bent, and bezel screws are tightened.
- Check AC input power for proper voltages. Be sure the jumper in the back of the power supply is set for the appropriate voltage.

- Be sure that all I/O interface cables are properly connected to I/O interface connectors.
 - All the configured bases are properly connected, there are no crimps or breaks in the cable, and base addresses are correct.
 - The cable to the programming unit (where applicable) is secure.
 - PLC battery polarity is correct.
3. Initialize PLC.
- For TI535 models —**
- If you have not already done so, disable the PLC battery by turning off switch 1 on DIP 2. Make certain that a programmed EPROM/EEPROM is not installed.
- Turn on power to the PLC.
- With the battery disabled and no programmed EPROM/EEPROM installed, the TI535 clears memory and enters PROGRAM mode.
- Enable the battery by turning on DIP 2, switch 1. The Battery Good LED should light. The TI535 is now initialized.
- For TI525 models —**
- Turn on power to the PLC. The TI525 is initialized during power-up.
4. If you intend to use an EPROM/EEPROM, install the EPROM/EEPROM according to the instructions given in Chapter 4.
5. Connect the programming device to the RS-232-C/RS-423 port of the PLC. Place the PLC in PROGRAM mode. If you have installed a pre-programmed EPROM/EEPROM, go to step 8.

NOTE

The PLC should be in PROGRAM mode at this point, not in RUN mode. Instructions that you enter in the RLL program are executed immediately if the PLC is in RUN mode.

6. Using the programming device, enter the I/O configuration.
7. Enter the RLL program. See the *SIMATIC TI505 Programming Reference* manual for information about designing your RLL program.
8. Use the programming device to JOG motors, solenoids, or other positioning devices one at a time to establish correct rotation or position.

After all the steps are performed and verified, place the PLC in the RUN mode. If you turn ON the L-memory MEMORY PROTECT dipswitch, your RLL program cannot be changed by a programming device that is connected to the PLC through one of the communication ports.

NOTE

The MEMORY PROTECT dipswitch does not prevent forcing I/O, changing variable memory, or switching the PLC from PROGRAM to RUN mode. These actions may be made by a programming device connected to the PLC, or a special function I/O module designed for this type of interface to the PLC, e.g., a Network Interface Module. The RLL can also be changed through a special function module, even when the memory protection is enabled.

5.2 USING THE TROUBLESHOOTING TOOLS

This section offers information and guidelines for troubleshooting TI525/TI535 PLCs. If you cannot locate the source of the problem, contact your Siemens Industrial Automation distributor or sales office. If you need assistance in contacting your U.S. sales office, call 1-800-964-4114.

5.2.1 Reading the LED Indicators

The three LEDs on the PLC are labeled RUN, BATTERY GOOD, and PLC GOOD. When the LEDs are on, they indicate status as shown in Table 5-1 and can aid in locating the source of a problem. The PLC LEDs are meaningful only when the DC POWER GOOD LED on the power supply is turned on.

Table 5-1 LED Indicators

RUN	ON = PLC is in Run mode
BATTERY GOOD	ON = Battery is good and battery dipswitch is on
PLC GOOD	ON = PLC is functioning with no fatal errors

5.2.2 Executing the Auxiliary Functions

The TI525/TI535 PLCs offer self-checking and diagnostic capabilities for troubleshooting purposes. The diagnostics and self-checks are accessible through the Auxiliary Function menu on the programming device.

When you display the Auxiliary Function menu, the following functions are available for resetting the PLC, initiating diagnostics or displaying diagnostic information:

- AUX 29 Show PLC diagnostic cell
- AUX 25 Display failed I/O
- AUX 20 Run PLC diagnostics
- AUX 11 Partial restart
- AUX 12 Complete restart
- AUX 10 Power-up restart

5.2.2.1 AUX Function 29 (Show PLC Diagnostic Cell)

AUX Function 29 checks the operational status of the PLC and displays the results. The display provides the information illustrated in Figure 5-1.

TI525/TI535 Operational Status	
Scan = 027 Milliseconds/Variable	Battery = On
Key = Unlocked	Download = Off
Mode = RUN	Program in RAM
Fatal Error = None	
Non-fatal Error = None	

Figure 5-1 Example of AUX Function 29 Screen

The scan time reported by AUX Function 29 is the highest scan time recorded since the last PLC reset or PROGRAM-RUN mode transition. Status Word 10 (STW10) contains a continuously updated report of the scan time.

5.2.2.2 AUX Function 25 (Display Failed I/O)

AUX Function 25 displays the locations of any failed I/O modules which are capable of diagnosing and indicating failure. Some modules, such as word and analog modules, report that they have failed if the user-supplied voltage is not correct.

AUX Function 25 also displays I/O mismatch(es), indicating that one or more installed module(s) do not agree with the I/O configuration. Verify that the configuration data for listed modules is correct before considering that the module may actually be malfunctioning.

5.2.2.3 AUX Function 20 (Run PLC Diagnostics)

AUX Function 20 initiates the PLC self-checks. The PLC must be in PROGRAM mode in order to execute self-tests. The PLC executes the equivalent of an AUX Function 20 at every power-up. If any area fails, a message detailing the failure is displayed. AUX Function 20 makes the following tests:

- Valid RAM locations are verified.
- Pre-coded ROM checksum values are checked.
- The hardware force function is checked.
- Internal timer operation is verified.
- Operating system ROM cyclic redundancy check code is checked.

5.2.2.4 AUX Function 11 (Partial Restart)

AUX Function 11 clears the discrete and control relay image registers, but does not affect forced elements, retentive control relays, preset values, and word image registers. AUX Function 11 puts the PLC in PROGRAM mode only if a fatal error is present or the previous mode was PROGRAM.

5.2.2.5 AUX Function 12 (Complete Restart)

AUX Function 12 clears the discrete, control relay, and word image registers and the retentive control relays, but does not affect forced elements and word registers. All preset values are downloaded at restart. AUX Function 12 puts the PLC in PROGRAM mode only if a fatal error is present or the previous mode was PROGRAM.

5.2.2.6 AUX Function 10 (Power-up Restart)

AUX Function 10 clears all discrete and non-retentive control relay image registers except those elements that are forced. Other results of AUX Function 10 depend on the following conditions:

- If the battery is low, AUX Function 10 clears the RLL program, I/O configuration, retentive control relays, WXs, WYs, forced I/O, V memory, and all timer, counter, and drum preset/current values.

If the battery is low and a program is in RAM, AUX Function 10 puts the PLC in PROGRAM mode. If the battery is low and an EPROM/EEPROM with a valid program is installed, AUX Function 10 puts the PLC in RUN mode.
- AUX Function 10 downloads presets in either of the following situations: (a) the battery is good and the download select switch is set, or (b) the battery is low and a program is in EPROM/EEPROM.
- AUX Function 10 also puts the PLC in PROGRAM mode if (a) the battery is good and a fatal error is present or (b) the battery is good with no error and the previous mode was PROGRAM.

Table 5-2 lists the effects on memory locations when AUX Functions 10, 11, and 12 are executed.

Table 5-2 Effects of Aux Functions on Memory Locations

Operation Selected	Image Register				Control Relay		Forced I/O	TMR/CTR DRUM Presets
	Discrete Input	Discrete Output	Word Input	Word Output	Retentive	Non-Retentive		
AUX 10	Cleared	Cleared	Note 1	Note 1	Note 1	Cleared	Note 1	Note 2
AUX 11	Cleared	Cleared	No Change	No Change	No Change	Cleared	No Change	No Change
AUX 12	Cleared	Cleared	Cleared	Cleared	Cleared	Cleared	No Change	Download

Note 1 No change if the battery is good; otherwise, cleared.
 Note 2 Dependent on user-selectable switch, memory type, and battery condition.

5.2.3 Troubleshooting with Status Words

In addition to the auxiliary functions described above, the TI525/TI535 PLCs provides operational information in the form of status words. These status words can be read with the programming device. Status words may also be contained within an RLL program so that diagnostics can be executed during run-time conditions.

5.2.3.1 Status Word One (STW01)

STW01 provides information in the word format shown in Figure 5-2. STW01 shows the status (good or failed) of the PLC battery, scan overrun, communication port, I/O modules, indirect table move overflow, and special function modules. A bit containing a 0 indicates no error, while a 1 indicates a problem or failure.

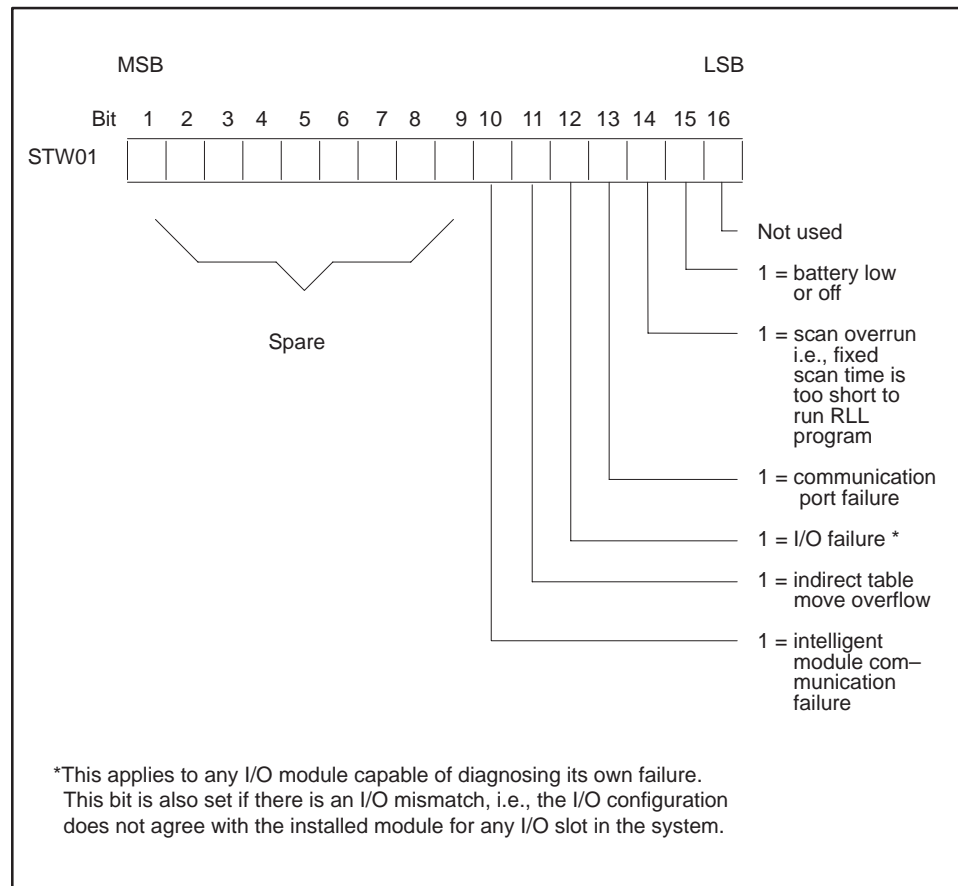

Figure 5-2 Format of Status Word One (STW01)

5.2.3.2 Status Word Two (STW02)

As illustrated in Figure 5-3 below, STW02 shows the status of up to sixteen bases. From right to left, each bit in the word represents a base. The bit is set to 1 when the base that it represents has failed or is not present, and it contains a 0 if the base is good. An empty base is reported with a 0, and bases 0 and 1 are always reported with a 0.

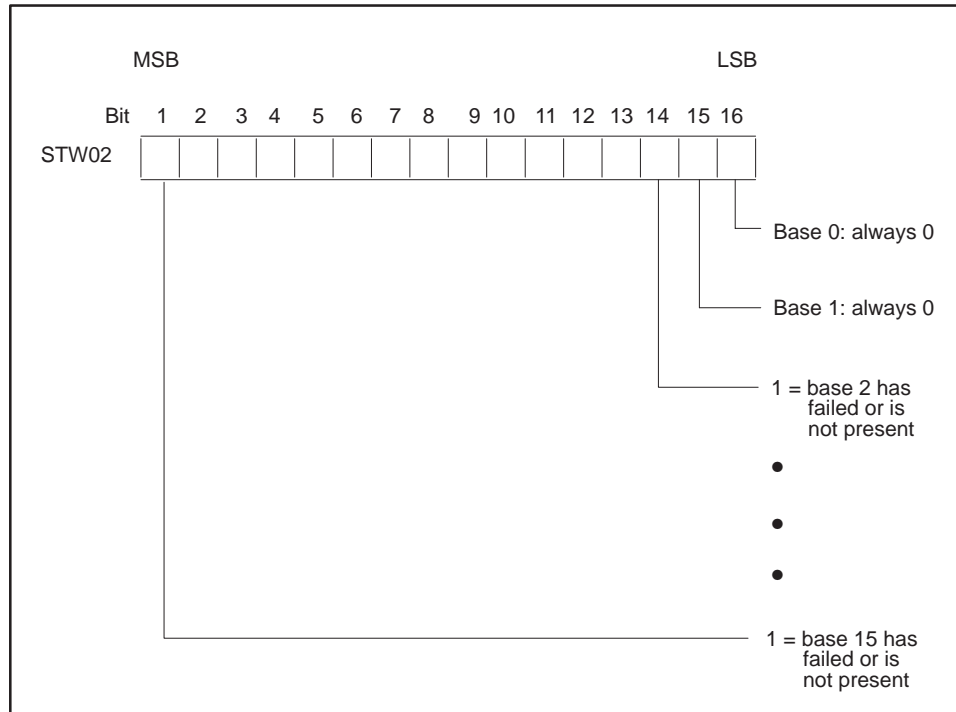

Figure 5-3 Format of Status Word Two (STW02)

NOTE

Status words three through five are not used by the TI525/TI535.

5.2.3.3 Status Word Six (STW06)

As illustrated in Figure 5-4 below, STW06 reports the status of EEPROM programming. Only one bit is set at a time.

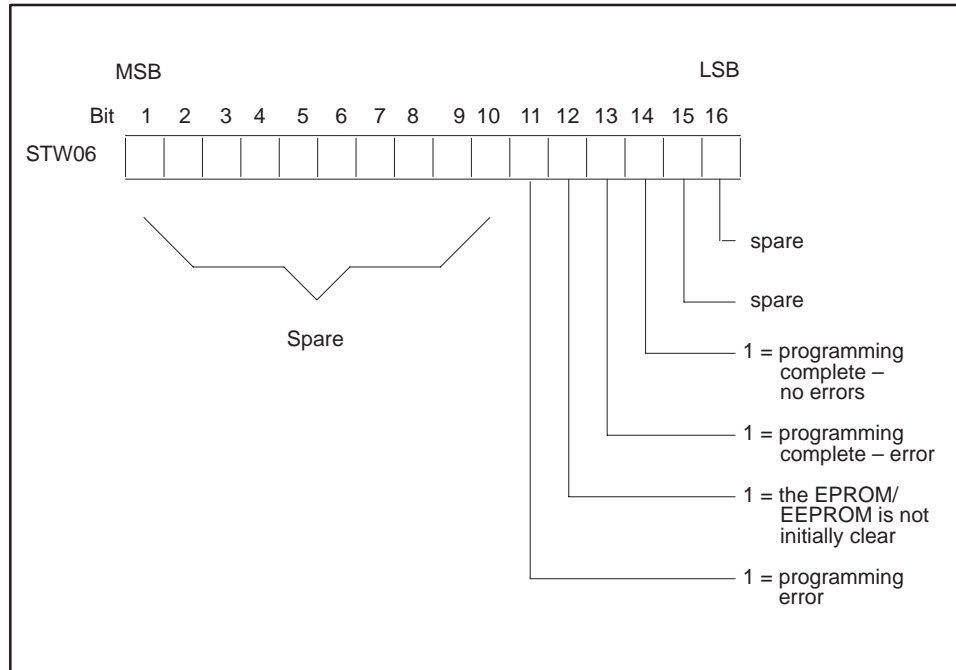

Figure 5-4 Format of Status Word Six (STW06)

5.2.3.4 Status Words Seven to Nine (STW07–STW09)

STW07 gives the absolute address of the first error encountered while attempting to program the EPROM/EEPROM. The value given is the memory address of the EPROM/EEPROM memory.

STW08 shows the checksum calculated from the RLL program stored in the EPROM/EEPROM. The checksum is a numerical calculation based on your RLL program only. When you copy a program to several EPROM/EEPROMs, you can check STW08 for every EPROM/EEPROM to verify that the information contained in each is identical.

NOTE

Identical RLL programs and identical I/O configurations programmed in different machines may yield different checksums due to internal storage differences.

STW09 shows the checksum generated from the EPROM/EEPROM. The checksum is a numerical calculation based on all data stored in the EPROM/EEPROM, including your RLL program and information contained in the I/O configuration memory. When you copy a program to several EPROM/EEPROMs, you can check STW09 for every EPROM/EEPROM to verify that the information contained in each is identical.

5.2.3.5 Status Word Ten (STW10)

STW10, shown in Figure 5-5, provides the PLC scan time in binary code. If you display the integer value of the word, the program scan time is given in milliseconds. The PLC updates the word each scan.

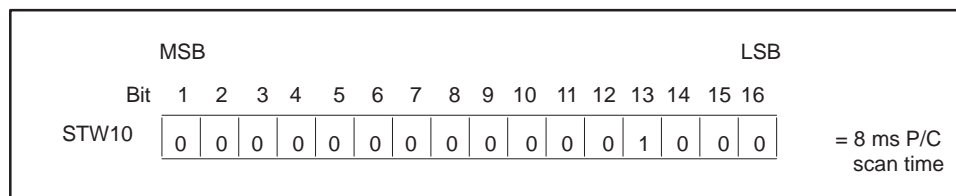

Figure 5-5 Format of Status Word Ten (STW10)

5.2.3.6 Status Words Eleven to Eighteen (STW11–STW18)

Status Words 11 through 18 report the status of the I/O modules contained on the logical bases, as shown in Figure 5-6. Each bit corresponds to one module in the base. If the module is in proper working order or if there is no module in that slot, the corresponding bit is 0. If the occupied slot contains a malfunctioning module, the bit is 1. See the example shown in Figure 5-7.

The PLC reports an I/O mismatch — an installed module does not agree with the I/O configuration — as a failed I/O module. The module has not actually failed. You should re-enter the I/O configuration for the slot in question.

Bit Number (Status Words 11–18)																
1	2	3	4	5	6	7	8	9	10	11	12	13	14	15	16	
				Slot 5			Slot 1				Slot 5				Slot 1	
		Slot 6				Slot 2				Slot 6				Slot 2		
Slot 7				Slot 3					Slot 7				Slot 3			
			Slot 8		Slot 4				Slot 8			Slot 4				
Logical Base B								Logical Base A								
Status Word	Logical Base B				Logical Base A											
11	Base 1				Base 0											
12	Base 3				Base 2											
13	Base 5				Base 4											
14	Base 7				Base 6											
15	Base 9				Base 8											
16	Base 11				Base 10											
17	Base 13				Base 12											
18	Base 15				Base 14											

Figure 5-6 Format of Status Words Eleven to Eighteen (STW11–18)

In Figure 5-7, the 1 in Bit 10 indicates that slot seven in Base 0 contains a malfunctioning or incorrectly configured module (I/O mismatch). All other slots either contain a working module or no module at all.

		Bits in Status Word 11																
Bit #		1	2	3	4	5	6	7	8	9	10	11	12	13	14	15	16	
Value		0	0	0	0	0	0	0	0	0	1	0	0	0	0	0	0	
												↓						
Slot #		8	7	6	5	4	3	2	1	8	7	6	5	4	3	2	1	
Base		Base 1								Base 0								

Figure 5-7 Example of a Status Word With a Bit Set

NOTE

When a distributed base loses communication with the PLC, the appropriate bit in STW02 shows a 1, and the corresponding bits in STW12 to STW18 show zeroes, even if modules on that base have failed or been incorrectly configured. That is, modules do not show failures on a base that is not present.

5.2.4 Clearing PLC Fatal Errors

A fatal error has occurred when both the following conditions hold:

- PC GOOD LED is not lighted.
- The DC GOOD LED on the power supply is on.

The PLC enters a fatal error condition and ceases operation if a problem listed below occurs:

- Watchdog time-out: The microprocessor does not reset a watchdog circuit periodically.
- Illegal operation code: The microprocessor receives an illegal instruction.
- Diagnostic test failure: The PLC fails a diagnostic test.
- I/O fatal error: The PLC detects a non-recoverable I/O error
- ROM diagnostic failure: The operating system EPROMs are found to be invalid.
- Operating system fatal error: The PLC detects a non-recoverable error during execution.
- Abnormal power loss: Power to the PLC is removed without proper warning.
- Dynamic Program Memory Diagnostics Error: The PLC determines a checksum error in the user EPROM/EEPROM or RAM.

When a fatal error occurs, the PLC takes the following actions:

- The PC GOOD LED is turned off.
- I/O ports are disabled. Discrete outputs are turned off, and word outputs are held in their last valid state.
- Communication ports are cleared and re-initialized.
- Pending or queued tasks are cleared.

Attempt to clear the fatal error by following the steps listed below. When the PC GOOD LED turns on, the fatal error has been cleared.

1. Determine the fatal error condition by selecting AUX Function 29 from the Auxiliary Function Menu on your programming unit. Record the fatal and non-fatal error(s) listed along with the date, time, and PLC serial number for later reference.

NOTE

Always execute AUX Function 29 and make a list of the errors before attempting to clear them. If you clear errors before listing them, it will be impossible to determine what errors occurred and difficult to identify the problem that caused them.

If communication errors occur, cycle power to the PLC. If communication errors continue, record “No Communication” as the fatal error and go to step 4.

2. Execute AUX Function 11 — PLC partial restart. If this fails to clear the error, execute AUX Function 12 — PLC complete restart.
3. If the fatal error persists, make certain that the battery backup is enabled and execute AUX Function 10 — PLC power-up restart.
4. If you have been unable to clear the fatal error to this point, you must re-initialize the PLC. **This clears the PLC memory.**

For a TI535, disable the battery backup (turn off switch 1 of DIP 2) and cycle power to the PLC (or execute AUX Function 10).

For a TI525, power down and remove the PLC from the base. Disable the battery backup (turn off switch 1 of DIP 2), insert the PLC in the base, and power up.

5. If the PC GOOD LED comes on, restore the battery backup by turning on switch 1 of DIP 2. (For a TI525, you must power down again and remove the PLC from the base to re-enable battery backup.) You must now use your programming unit to restore your program.

6. If the PC GOOD LED does not turn on at this time, your PLC may have a hardware failure. Contact your Siemens Industrial Automation distributor or sales office. If you need assistance in contacting your U.S. sales office, call 1-800-964-4114. Have the following information available before you call:
 - List of fatal and non-fatal errors
 - PLC serial number
 - PLC software revision (execute AUX Function 15 or check the PLC label)
 - Sequence of events leading up to the failure

5.2.5 Troubleshooting the EPROM/EEPROM

From the Status Chart or WORDS display of the programming device, you can check the values in the status words STW06, STW07, STW08, and STW09 for problems with the EPROM/EEPROM. You should also check for the following:

- The EPROM used in the TI520/TI530 PLCs is not compatible with the TI525/TI535. A TI520C/TI530C EPROM may be used in a TI525/TI535, however.
- If you transfer an EPROM/EEPROM from one TI525/TI535 model to another, remember that the program in the EPROM/EEPROM has to be compatible with the model in which it is used.
- If the program that you loaded in RAM fails to copy to the EEPROM, check the EPROM/EEPROM jumpers to be sure that you have them set for an EEPROM, not an EPROM.

Refer to Chapter 4 of this manual for instructions on installing and programming the EPROM/EEPROM.

5.2.6 Troubleshooting the Power Supply

Complete the following steps when troubleshooting the power supply:

1. Determine that the power budget has not been exceeded and that the module is properly installed.
2. After making sure the battery is on (so the program will not be lost), disable all power to the system for at least 90 seconds.
3. Restore system power.
4. If the problem still exists, turn off power to the system.

WARNING

To avoid the potential risk of damage to equipment or injury to personnel, always turn off power to the system before removing the power supply from the base.

5. Remove the power supply from the base. This step is not required for the PPX:505–6663 power supply.
 - a. Make sure the jumper in the back of the module is set to the correct line voltage.
 - b. If the voltage has been set incorrectly, wait at least one minute before touching the jumper. Then move the jumper to the appropriate quick-connect pin.
6. Make sure the wires attached to the terminal screws on the bezel are secure and that the user-supplied power source is functional.
7. Check to see that the fuse (located on the bezel) has not opened. Replace the fuse, if necessary, with the appropriate fuse.
 - a. Using a flat-blade screwdriver, twist the fuse holder once, counter-clockwise, to remove the fuse holder.
 - b. To replace the fuse holder, insert, push, and turn clockwise to secure.
8. Replace the power supply and enable power to the system.
9. If the power supply continues to malfunction, replace it.

If replacing the fuse does not solve the problem, and the power source is correctly connected, then the power supply module should be returned for repair. Contact your local distributor for assistance.

5.2.7 Spare Parts

It is recommended that you keep on hand a 10% surplus of your system's I/O modules. Depending upon the number of PLCs that you have installed, you may wish to stock an extra PLC as well. The following is a list of other spare parts that you should have available.

- PPX:505–6504, 4 I/O slots
- PPX:505–6508, 8 I/O slots
- PPX:505–6516, 16 I/O slots (19-inch rack compatible)
- Power Supply Module, PPX:505–6660, PPX:505–6660A or PPX:505–6663
- 3 V lithium battery, PPX:2587678–8005
- 3.0 A/250 V, slow-blow fuse 3 AG for PPX:505–6660
- 8.0 A/250 V, normal-blow fuse 3 AG for PPX:505–6663

You can order the following spare parts from your distributor.

- EEPROM, PPX:2587681–8020
- 525 12 Kbytes Upgrade Kit, PPX:2586491–8003

APPENDIX A

SPECIFICATIONS

Environmental Specifications (All P/C models and power supply)	General Specifications (All P/C models)
Storage Temperature –405 to 705C; –405 to 1585F	Input Power Provided by power supply module PPX:505–6660 for user-supplied 110/220 VAC. PPX:505–6663 for user-supplied 24 VDC. Maximum power drawn from base by TI525: 10 W @ +5 VDC, 0.5 W @ –5 VDC Maximum power drawn from base by TI535: 12.5 W @ +5 VDC, 0.2 W @ –5 VDC
Operating Temperature 05 to 605C; 325 to 1405F	Battery Backup 3.0 V lithium battery (PPX:2587678–8005) 3 years typical storage (05 to 605C) 6 months typical storage (05 to 605C)
Relative Humidity 5% to 95% noncondensing	Communication Ports RS-232-C/RS-423: all models RS422: PPX:525–1208, PPX:525–1212 PPX:535–1204, PPX:535–1212
Vibration Sinusoidal: IEC 68–2–6, Test Fc; 0.15 mm peak to peak, 10–57 Hz; 1.0 g, 57–150 Hz Random: NAVMAT P–9492 or IEC 68–2–34, Test Fdc with 0.04g ² /Hz, 80–350 Hz, and 3dB/octave rolloff, 80–20 Hz and 350–2000 Hz at 10 min/axis	User Memory Capacity 2K, 4K, 8K, or 12K of RLL memory, depending on the model.
Impact Shock IEC, 68–2–27, Test Ea; Half sine, 15g, 11 ms	Memory Backup EEPROM (PPX:2587681–8020) Battery backed-up static RAM
Pollution degree 2, IEC664, 664A	Corrosion Protection All parts are of corrosion-resistant material or are plated or painted as corrosion protection.
Electric Noise Immunity Conducted noise: IEC 801, Part 4, Level 3 MIL–STD–461B, Part 4; CS01, CS02, CS06 IEC 255–4, Appendix E EEC 4517/79 Com(78) 766 Final, Part 4 IEEE 472, 2.5 kV Radiated noise: IEC 801 Part 3, Level 3 MIL–STD–461B, Part 4; RS01, RS02 Electrostatic discharge: IEC 801, Part 2, Level 4 (15 KV)	Agency Approvals (All PLC models and power supply) UL Listed (industrial control equipment) CSA Certified (process control equipment)
System Isolation Isolation (user-side to PLC-side): 1500 Vrms	

APPENDIX A – SPECIFICATIONS

<p style="text-align: center;">Electrical Specifications</p> <p style="text-align: center;">Power Supply</p> <p style="text-align: center;">Input voltage select</p> <p>110 or 220 VAC (User-selectable) PPX:505-6660</p> <p style="text-align: center;">Voltage range</p> <table style="width: 100%; border: none;"> <tr> <td style="width: 50%;">85-132 VAC (110)</td> <td style="width: 50%;">PPX:505-6660</td> </tr> <tr> <td>170-264 VAC (220)</td> <td>PPX:505-6660</td> </tr> <tr> <td>20-30 VDC (24)</td> <td>PPX:505-6663</td> </tr> </table> <p style="text-align: center;">Frequency</p> <p>47-63 Hz PPX:505-6660 PPX:505-6660</p> <p style="text-align: center;">Input current</p> <table style="width: 100%; border: none;"> <tr> <td style="width: 50%;">Peak inrush: 50 A maximum</td> <td style="width: 50%;">PPX:505-6660</td> </tr> <tr> <td>20 A maximum</td> <td>PPX:505-6663</td> </tr> <tr> <td>Steady state: 2 A rms maximum</td> <td>PPX:505-6660</td> </tr> <tr> <td>8 A zero to peak</td> <td>PPX:505-6660</td> </tr> <tr> <td>5 ADC maximum</td> <td>PPX:505-6663</td> </tr> <tr> <td>Volt-Amp rating: 200 V-A</td> <td>PPX:505-6660</td> </tr> <tr> <td>Wattage Rating: 100 W maximum</td> <td>PPX:505-6663</td> </tr> </table> <p style="text-align: center;">Output</p> <p>55 W at +5 VDC 3.75 W at -5 VDC</p>	85-132 VAC (110)	PPX:505-6660	170-264 VAC (220)	PPX:505-6660	20-30 VDC (24)	PPX:505-6663	Peak inrush: 50 A maximum	PPX:505-6660	20 A maximum	PPX:505-6663	Steady state: 2 A rms maximum	PPX:505-6660	8 A zero to peak	PPX:505-6660	5 ADC maximum	PPX:505-6663	Volt-Amp rating: 200 V-A	PPX:505-6660	Wattage Rating: 100 W maximum	PPX:505-6663	<p style="text-align: center;">Fuse</p> <p>3.0A/250 V, slow-blow, 3 AG PPX:505-6660 8.0A/250 V, normal-blow, 3 AG PPX:505-6663</p> <p style="text-align: center;">General</p> <p style="text-align: center;">Corrosion protection</p> <p>All parts are of corrosion-resistant material or are plated or painted as corrosion protection.</p>
85-132 VAC (110)	PPX:505-6660																				
170-264 VAC (220)	PPX:505-6660																				
20-30 VDC (24)	PPX:505-6663																				
Peak inrush: 50 A maximum	PPX:505-6660																				
20 A maximum	PPX:505-6663																				
Steady state: 2 A rms maximum	PPX:505-6660																				
8 A zero to peak	PPX:505-6660																				
5 ADC maximum	PPX:505-6663																				
Volt-Amp rating: 200 V-A	PPX:505-6660																				
Wattage Rating: 100 W maximum	PPX:505-6663																				

In addition, the system complies with applicable requirements of Verband Deutscher Elektrotechniker (VDE) 0160: Electrical Equipment, except 220 VAC Input Modules (No. 505-44XX)

Series 505 products have been developed with consideration of the draft standard for programmable controllers as described in the proposed standard of the International Electrotechnical Commission Committee (IEC-65A/WG6, Part 2).

Information concerning product reliability and compliance to the IEC or other standards can be provided upon request. Contact your Siemens Industrial Automation distributor or sales office. If you need assistance in contacting your U.S. distributor or sales office, call 1-800-964-4114.

APPENDIX B

GROUNDING AND ELECTRICAL GUIDELINES

B.1 INTRODUCTION

This appendix describes measures you can take to provide a good earth ground to your system, lists steps you can perform to ensure that your system is not influenced by electrical noise, and gives instructions for proper wiring.

B.2 GROUNDING

A good grounding system is essential for proper operation of the Series 505 controllers. All filtering devices internal to the 505 system require a good earth ground for reference. The structural ground present in many industrial environments does not provide an adequate ground return when direct wire connection to the power system is not feasible. As a minimum, use #12 AWG stranded copper wire for the ground return. Minimum wire sizes, color coding, and general safety practices should comply with all appropriate electrical standards and codes. Screw connections between bezels and bases, as well as between enclosures and bases, provide grounds and should be tightened properly.

B.2.1 Single Point Grounding

Connect any Series 505 component with an external chassis or external ground terminal on its power connectors to the subpanel ground bus. This connection should exhibit very low DC resistance (0.05 ohm) and low high-frequency impedance.

Connect the subpanel ground bus to a single-point ground, such as a copper bus bar to a good earth ground reference. The single point ought to be the center of a “star” configuration to minimize device-to-ground distances.

To achieve low impedance from device to single-point termination, 0.65 centimeter or larger ground braid should be used. A good rule of thumb is to require less than 0.1 ohm of DC resistance between device and single-point ground. This is accomplished by removing the anodized finish and using copper lugs and star washers.

B.2.2 Guidelines for Ground Connections

Use particular care when establishing the ground connections. The following techniques will help in establishing good electrical connections and increasing system noise immunity:

- Terminate grounding braid and green wires at both ends with copper eye lugs to provide a good contact surface. Lugs should be crimped and soldered.
- Use #10 copper bolts (or equivalent) for those fasteners providing electrical connections to the single-point ground. This applies to device-mounting bolts and braid termination bolts for subpanel and user-supplied single points. Tapped holes for these fasteners are better than nut-bolt arrangements.
- Paints, coatings, and corrosion can prevent good electrical contact at ground points. Remove these impediments in the area of contact and use external toothed lock washers (star washers) to ensure good continuity and low impedance. This practice should be used for all terminations — lug to subpanel, device to lug, device to subpanel, subpanel to conduit, etc. Examples of ground connections are shown in Figure B-1.

APPENDIX B – GROUNDING GUIDELINES

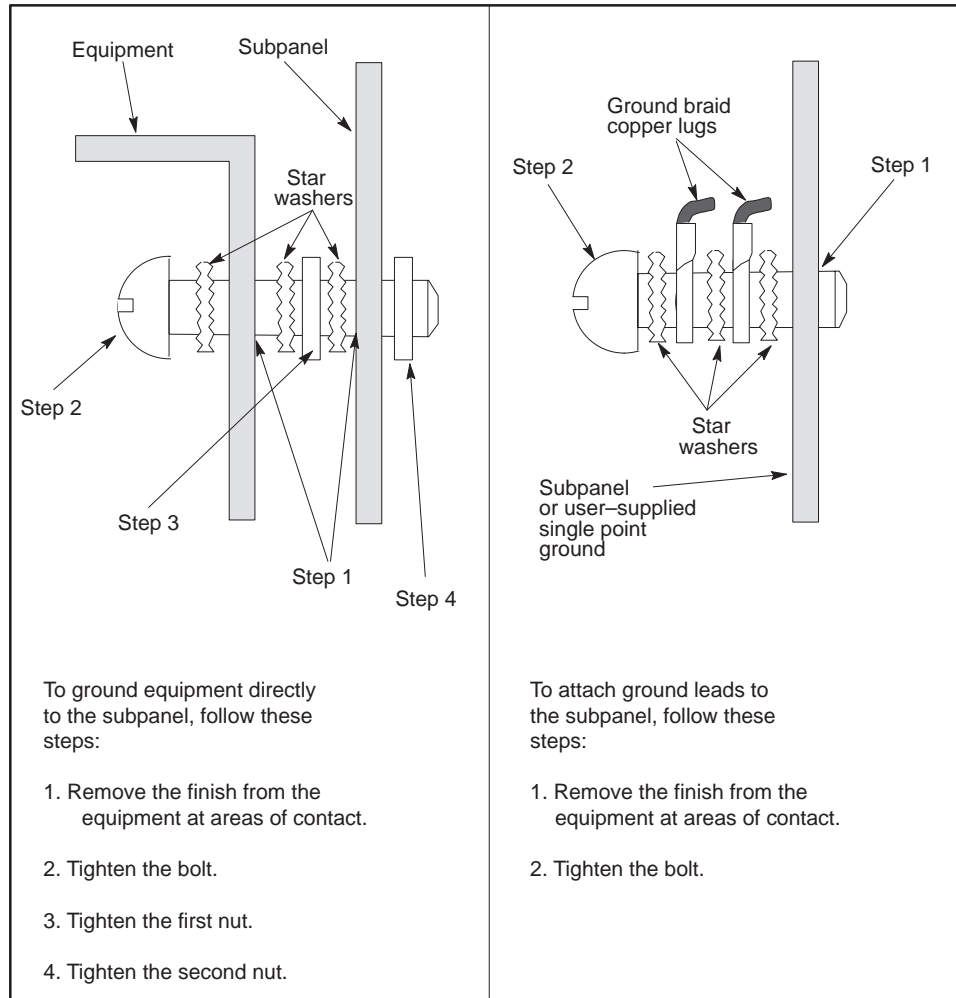

Figure B-1 Sample Ground Connections

B.3 WIRING GUIDELINES

Consider the following guidelines before installing any system or power wiring.

- Always use the shortest possible cable.
- Use a single length of cable between components.
- Do not connect short pieces of cable to obtain additional length.
- Avoid placing system and field wiring in the vicinity of high-energy wiring.
- Keep field input wiring, output wiring, and all other types of wiring in the panel physically separated.
- Consider separating DC field wiring from AC field wiring wherever possible.
- Avoid sharp bends to power and data cables. Use 7.6 cm (3 inch) radius on all bends.
- A good low ground impedance of 0.1 ohm or less must exist for all components in the system.
- Use wireways for wire and cable routing when possible.
- Keep wire strippings from falling into modules, controllers, or bases.
- For long return lines to the power supply, do not use the same wire for input and output modules. Using separate return wiring for these modules minimizes the voltage drop on the return lines of the input connections.

B.4 MINIMIZING ELECTRICAL NOISE

The following paragraphs provide information to help reduce the possibility of electrical noise problems.

B.4.1 Definition and Source

Electrical noise is defined as any unwanted electrical signal which enters the control equipment. Noise signals cover the entire spectrum of frequencies and may have any waveshape. The largest single difficulty with noise is that it is not always present. Continuous, or frequent, periodic noises generally are easy to detect and remedy. Intermittent noise sources that produce short, high-energy bursts at irregular and widely spaced intervals cause the majority of difficulties.

Noise has a number of different pathways into control equipment. It can be conducted through signal or power wiring or can be radiated by electromagnetic waves. Conducted noise typically is coupled with the signal or power wiring, either electrostatically or magnetically. Electrostatic coupling occurs through parasitic capacitance between the noisy line and the signal/power line. This requires high voltage or high rate of change of voltages in the noisy line and high parasitic capacitance between lines. This typically would be the case for long wire runs in the same conduit.

Magnetic coupling occurs through parasitic mutual inductances between lines. This requires high currents or high rates of change of current, as well as significant mutual inductance, which may result from proximity of wiring.

Electromagnetically radiated noise typically is high frequency (radio waves). The control system and its wiring may act as antennas in picking up noise signals. This pathway is least likely to present problem levels of noise, but its sources are common in industrial applications.

The primary sources of noise in industry are those devices (and their wiring) that produce and switch high voltage and current. Typical examples include large motors, welders and contactors that switch heavily inductive loads such as brakes or clutches.

APPENDIX B – GROUNDING GUIDELINES

B.4.2 Correcting Noise Problems

When potential noise sources are identified, two general methods are available to correct them. These methods are noise suppression and noise isolation.

B.4.2.1 Noise Suppression

You can use noise suppression (snubbing) to reduce noise at its source. Applicable only to devices driven by mechanical contacts, snubbing suppresses arcing at electrical contacts caused by turnoff of inductive loads (e.g., relays, motors, motor starters, solenoids, etc.). Load side suppression reduces voltage transients at the load, preventing them from traveling back to the contacts where they would produce a showering arc and couple with adjacent wiring.

You may achieve an alternative type of suppression by placing an RC or varistor circuit (shown in Figure B-2) across the contacts, parallel to the switch.

Both types of snubbing cause the physical devices to come on or go off more slowly. The RC and varistor elements should have minimal effect on system timing: their time constants are substantially less than 1 millisecond.

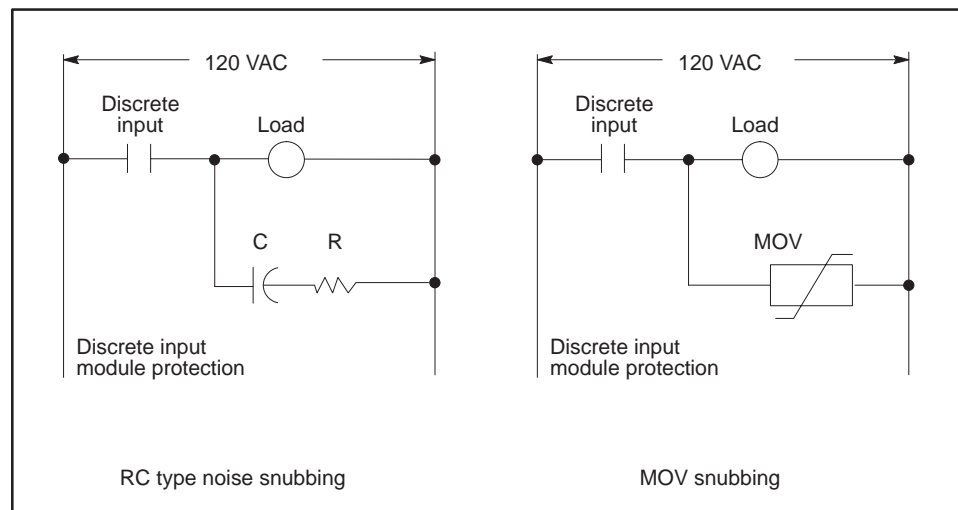

Figure B-2 Examples of Noise Snubbing

B.4.2.2 Isolation

The second approach to handling noise problems is to isolate the problem device and its wiring from the electronics and associated signal wiring. You may accomplish this by increasing the physical distance from some types of noisy devices. For extreme cases, electrostatic (metal) shielding may be required. This is true for noise sources outside as well as inside the mounting cabinet (NEMA-type recommended).

Two cases of field wiring warrant special attention: Wiring which enters the harsh-noise area to enable monitoring and control of those devices, and TTL or low-level (less than 24 V) wiring. In these cases, supplement the physical separation between control and noise-prone wiring with shielded, twisted-pair wiring (12 twists/ft) for the control signals.

Ground the shield at the electronics side only to the single-point ground.

APPENDIX C

SERIES 500/505 I/O POWER CONSUMPTION

The power requirements for all currently available Series 505 and Series 500 I/O modules are given in Table C-1 and Table C-2, respectively.

Table C-1 Series 505 Component Power Requirements
(Continued on next Page)

		Power Available (in watts)	
		+5 V	-5 V
PPX:505-6660	Power Supply	55	3.75
PPX:505-6660A	Power Supply	55	3.75
PPX:505-6663	Power Supply	55	3.75
Model Number		Max. DC Power Required (in watts)	
Model Description		+5 V	-5 V
PPX:505-6830	IOCC	5.0	0.1
PPX:505-6840	Distributed Base Controller	5.0	0.1
PPX:505-4008	24 VAC Input (8 point)	2.0	—
PPX:505-4016	24 VAC Input (16 point)	2.0	—
PPX:505-4032	24 VAC Input (32 point)	2.0	—
PPX:505-4108	LVDC/TTL (8 point)	2.0	—
PPX:505-4116	LVDC/TTL (16 point)	2.0	—
PPX:505-4132	LVDC/TTL (32 point)	2.0	—
PPX:505-4208	110 VAC Input (8 point)	2.0	—
PPX:505-4216	110 VAC Input (16 point)	2.0	—
PPX:505-4232	110 VAC Input (32 point)	2.0	—
PPX:505-4308	24 VDC Input (8 point)	2.0	—
PPX:505-4316	24 VDC Input (16 point)	2.0	—
PPX:505-4317	24 VDC Interrupt Input (16/32 point)	1.0	—
PPX:505-4332	24 VDC Input (32 point)	2.0	—
PPX:505-4408	220 VAC Input (8 point)	2.0	—
PPX:505-4416	220 VAC Input (16 point)	2.0	—
PPX:505-4432	220 VAC Input (32 point)	2.0	—

APPENDIX C – I/O POWER CONSUMPTION

Table C-1 Series 505 Component Power Requirements
(Continued)

Model Number	Model Description	Max. DC Poer Required (in watts)	
		+5 V	-5 V
PPX:505-4508	24 VDC Output (8 point)	2.5	—
PPX:505-4516	24 VDC Output (16 point)	2.5	—
PPX:505-4532	24 VDC Output (32 point)	2.5	—
PPX:505-4608	110 VAC Output (8 point)	2.5	—
PPX:505-4616	110 VAC Output (16 point)	2.5	—
PPX:505-4632	110 VAC Output (32 point)	2.5	—
PPX:505-4708	24 VDC Output (8 point)	5.0	—
PPX:505-4716	24 VDC Output (16 point)	5.0	—
PPX:505-4732	24 VDC Output (32 point)	5.0	—
PPX:505-4808	220 VAC Output (8 point)	5.0	—
PPX:505-4816	220 VAC Output (16 point)	5.0	—
PPX:505-4832	220 VAC Output (32 point)	5.0	—
PPX:505-4908	Relay Output Form C (8 point)	2.5	—
PPX:505-4916	Relay Output Form A (16 point)	2.5	—
PPX:505-4932	Relay Output Form A (32 point)	2.5	—
PPX:505-5100	TurboPlastic	7.0	0
PPX:505-5103	TurboParison	7.0	0
PPX:505-5184	MODNIM (Modbus NIM)	8.0	—
PPX:505-5190	6MTCC: TI505 to 6MT I/F	4.0	—
PPX:505-5417	16 Output Relay, 115 VDC	3.0	—
PPX:505-6010	Input Simulator	2.0	—
PPX:505-6011	Output Simulator	2.5	—
PPX:505-6108	Analog Input	4.0	—
PPX:505-6108A	Analog Input	4.0	—
PPX:505-6202	Analog Output (2 point)	2.5	—
PPX:505-6204	Analog Output (4 point)	5.0	—
PPX:505-6208	Analog Output (8 point)	5.0	—
PPX:505-6208A	Analog Output (8 point)	2.0	—
PPX:505-6308	Word Input	4.0	—
PPX:505-6408	Word Output	5.0	—
PPX:505-6851A	Remote Base Controller	5.0	0.200

APPENDIX C – I/O POWER CONSUMPTION

Table C-1 Series 505 Component Power Requirements
(Continued)

Model Number	Model Description	Max. DC Power Required (in watts)	
		+5 V	-5 V
PPX:505-7002	High Speed Counter & Encoder	2.5	—
PPX:505-7012	8 In/4 Out Analog	3.0	—
PPX:505-7016	Bipolar 8 In/4 Out Analog	6.5	—
PPX:505-7028	Thermocouple	2.2	0.01
PPX:505-7038	RTD	2.2	0
PPX:505-7101	BASIC Module	6.0	0.125
PPX:505-7339	NIM (Network Interface Module)	8.0	—
PPX:505-7340	Dual Media NIM	8.0	—
PPX:505-7354	Peerlink	8.0	—
PPX:505-ATM	IBM AT Compatible Coprocessor	11.0	0.2
-0220	IBM AT Compatible Coprocessor	11.0	0.2
-0440	IBM AT Compatible Coprocessor	11.0	0.2
-4120	IBM AT Compatible Coprocessor	11.0	0.2
PPX:545-1101	Programmable Logic Controller	4.0	0.200
PPX:525 CPUs	All models of TI525 CPUs	10.0	0.5
PPX:535 CPUs	All models of TI535 CPUs	12.5	0.2
PPX:555-1101	CPU	4.0	0.200

APPENDIX C – I/O POWER CONSUMPTION

Table C-2 Series 500 Component Power Requirements
(Continued on next Page)

		Power Available (in watts)	
		+5 V	-5 V
PPX:500-2151 AC Power Supply		54	3.75
PPX:500-2153 DC Power Supply		56	3.75
PPX:500-2103 Distributed Base Controller (Power Supply included)		45	2.50
Model		DC Power Required (in watts)	
Number	Model Description	+5 V	-5 V
PPX:500-2108	IOCC	5.0	0.1
PPX:500-2109	Distributed Base Controller	5.0	0.1
PPX:500-5001	110 VAC Input	1.0	—
PPX:500-5002	220 VAC Input	1.0	—
PPX:500-5003	110 VDC Input	1.0	—
PPX:500-5004	220 VDC Input	1.0	—
PPX:500-5005	24 V AC/DC Input	1.0	—
PPX:500-5006	48 V AC/DC Input	1.0	—
PPX:500-5007	TTL Input	1.0	—
PPX:500-5008	24 VDC Input	1.0	—
PPX:500-5009	Analog Input	3.0	—
PPX:500-5010	24/48 VAC Output	1.4	—
PPX:500-5011	110 VAC Output	1.4	—
PPX:500-5012	220 VAC Output	1.4	—
PPX:500-5013	24/48 VDC Output	1.4	—
PPX:500-5016	Analog Output	3.0	—
PPX:500-5018	Word Input	2.0	—
PPX:500-5019	Word Output	2.0	—
PPX:500-5020	Input Simulator	1.0	—
PPX:500-5021	Output Simulator	1.4	—
PPX:500-5022	ASCII	8.5	0.125
PPX:500-5023	High Speed Pulse Input	6.0	0.05
PPX:500-5024	SERVO AXIS Controller	7.5	0.15
PPX:500-5026	24 VDC Latching Input Rapid Response Output	2.0	—

APPENDIX C – I/O POWER CONSUMPTION

Table C-2 Series 500 Component Power Requirements
(Continued)

Model Number	Model Description	DC Power Required (in watts)	
		+5 V	-5 V
PPX:500-5027	110 VAC Latching Input Rapid Response Output	2.0	—
PPX:500-5028	120 VDC Latching Input Rapid Response Output	2.0	—
PPX:500-5029	Dual Communication Port	8.5	0.125
PPX:500-5030	32-Point 24 VDC Input	3.0	—
PPX:500-5031	32-Point 24 VDC Output	3.0	—
PPX:500-5032	110 VAC Isolated Input	1.0	—
PPX:500-5033	110 VAC Isolated Output	1.4	—
PPX:500-5035	BASIC	8.5	0.125
PPX:500-5037A	8-Channel Analog Input	2.0	—
PPX:500-5038	Network Interface—RS-232/Local Line Ports	8.0	0.625
PPX:500-5039	Network Interface—Dual Local Line Ports	8.0	1.25
PPX:500-5040	Network Interface—Dual RS-232 Ports	8.0	0.06
PPX:500-5041	110 VAC Redundant Output	2.5	—
PPX:500-5047	8-Channel Analog Output	2.0	—
PPX:500-5047A	8 Out, Analog	2.0	—
PPX:500-5048	24 VDC Isolated Input	1.0	—
PPX:500-5049	24 VDC Isolated Output	1.4	—
PPX:500-5051	Thermocouple	4.75	—
PPX:500-5052	Resistance Temperature Detector	3.5	—
PPX:500-5053	TIWAY Peerlink	6.5	0.625
PPX:500-5054	Redundant TIWAY Peerlink	6.9	1.25
PPX:500-5055	32-Point High Density 110 VAC Input	3.0	—
PPX:500-5056	32-Point High Density 110 VAC Output	3.0*	—
PPX:500-5061	High-current Relay	3.0	—
PPX:500-5062	Low-current Relay	3.0	—
PPX:500-5114	Remote Base Controller	6.0	0.200
PPX:500-5192	48 VDC Input	3.0	—
PPX:520C/530C	All models of TI520C/TI530C CPUs	11.0	0.3
PPX:530T	All models of TI530T CPU	14.0	0.2

* Some versions of the 500-5056 32-Point Output Module consume 3.3 watts of +5 VDC power. These units are appropriately identified with labels.

A

AUX Function

- AUX 10, 3-9, 3-12, 5-7, 5-15
- AUX 11, 5-6, 5-15
- AUX 12, 3-9, 3-12, 5-6, 5-15
- AUX 20, 5-6
- AUX 25, 5-6
- AUX 29, 5-5, 5-15
- AUX 84, 4-1, 4-8, 4-12
- Troubleshooting with, 5-5–5-7, 5-15

B

Base Assembly

- Installation, 3-2
- Models, 3-1
- Slots
 - Controller, 3-27
 - I/O Modules, 3-29
 - Power Supply, 3-25

Base Number Dipswitch, TI535, 3-10, 3-13

Base, Logical, 3-13, 3-19

Battery

- Backup Dipswitch
 - TI525, 3-5, 3-7
 - TI535, 3-10, 3-14
- Information Protected, 1-9, 3-7, 3-14
- Installation, 3-17

Baud Rate

- TI525, 3-5, 3-6
- TI535, 3-10, 3-15

Boolean Symbolic Code, 1-1, 1-8

C

Communication Ports

- Baud Rate
 - TI525, 3-5, 3-6
 - TI535, 3-10, 3-15
- Pinout, 3-28

Configuration

- TI525, 3-5–3-9
- TI535, 3-10–3-15

D

Diagnostics. *See* Status Word, AUX Function, Troubleshooting

Dipswitches

- TI525
 - Battery Enable, 3-5, 3-7
 - Baud Rate, 3-5, 3-6
 - Memory Protect, 3-8
 - Preset (download/retain), 3-5, 3-9
- TI535
 - Battery Enable, 3-10, 3-14
 - Baud Rate, 3-10, 3-15
 - Highest-Numbered Base, 3-10, 3-13
 - Memory Protect, 3-16
 - Preset (download/retain), 3-10, 3-12

Distributed Base, 1-3, 3-21

Distributed Base Controller (DBC), 1-3, 3-21, 3-32

Distributed I/O, 1-3, 3-21

E

Electrical Noise

- Definition, B-5
- Isolation, B-7
- Suppression, B-6

Emergency Stop Switch, 2-5

Enclosures, 2-6

EPROM/EEPROM

- AUX Function 84 and, 4-1, 4-8, 4-12
- Installation, 4-6
- Jumper Pins, 4-4–4-9, 5-17
- Operation At Power Up, 4-2
- Programming, 4-8
- Status Words and, 4-10
- Troubleshooting, 4-9–4-11, 5-17

Errors. *See* Fatal Errors, Status Words

INDEX

F

- Fatal Errors
 - Clearing, 5-15
 - Conditions, 5-14

G

- Grounding Guidelines, 2-7, B-1–B-4
- Guidelines
 - Grounding, 2-7, B-1–B-4
 - Handling Modules, 3-4
 - Module Installation, 3-23
 - Pre-installation, 2-1
 - Safety, 2-4–2-6
 - Temperature, 2-7

I

- I/O, selecting type of, 3-11
- I/O Channel Controller (IOCC), 1-3, 3-21, 3-32
- I/O Mismatch, 5-6, 5-13
- I/O Module
 - Base Power Budget and, 3-29
 - Handling Guidelines, 3-4
 - Installation, 3-29
 - Point Numbering, 3-22, 3-30
 - Power Budget, 2-1
 - Status Words and, 5-12
- Inch Switch, 2-6
- Initialization (P/C), 5-1–5-3
- Input/Output (I/O)
 - Distributed, 1-3, 3-13, 3-21
 - Local, 1-3, 3-13, 3-20, 3-22
- Installation
 - Base Assembly, 3-2
 - Base Controllers, 3-32
 - Battery, 3-17
 - Communication Cables, 3-27
 - EPROM/EEPROM
 - TI525, 4-4
 - TI535, 4-6
 - I/O Modules, 3-29
 - P/C, 3-27
 - Power Supply, 3-25
- Instruction Set (RLL), 1-7

J

- Jog Switch, 2-6
- Jumper Pins, EPROM/EEPROM, 4-4–4-9

L

- LED Indicators, 5-4
- Local I/O, 1-3, 3-20, 3-22
- Logical Base, 3-13, 3-19

M

- Memory
 - AUX Functions and, 5-7
 - Battery Backup, 3-7, 3-14
 - Features (by model), 1-6
 - Ladder Logic Memory (by model), 1-6
 - Memory Protect Dipswitch, 5-3
 - TI525 Models, 3-8
 - TI535 Models, 3-16
- Memory Protect Dipswitch, 1-10
- Modules
 - Handling Guidelines, 3-4
 - Installation Guidelines, 3-23

N

- NEMA Enclosures, 2-7

O

- Operator Safety Switch, 2-4

P

- P/C
 - Initialization, 5-1–5-3
 - Installation, 3-27
 - Troubleshooting, 5-14–5-16
- Port (Communication)
 - Baud Rate Dipswitch
 - TI525, 3-6
 - TI535, 3-15
 - Pin-Out, 3-27
- Power Budget, 2-1, 3-26, 5-18

INDEX

- Power Consumption
 - Series 500 Modules, C-4
 - Series 505 Modules, C-1
 - Power Supply
 - Installation, 3-25
 - Models, 1-5
 - Power Budget, 2-1, 3-26, 5-18
 - Troubleshooting, 5-18
 - Power Up
 - AUX Functions and, 5-7
 - Modes, 4-3
 - P/C Initialization, 5-1–5-3
 - Pre–installation Guidelines, 2-1
 - Preset Values
 - AUX Functions and, 3-9, 3-12, 5-6
 - Download/Retain Dipswitch
 - TI525, 3-9
 - TI535, 3-12
 - Primary Base, 3-20–3-21
 - Programming, EPROM/EEPROM, 4-8
 - Programming Devices, 1-2, 1-8
 - Programming Software, 1-8
- R**
- RLL Instruction Set, 1-7
- S**
- Safety Guidelines, 2-4–2-6
 - Safety Switch, 2-4
 - Scan Time
 - Boolean Logic, 1-1
 - Status Word 10 and, 5-11
 - Slots
 - I/O, 3-29
 - P/C, 3-27
 - Power Supply, 3-25
 - Software (Programming), 1-8
 - Spare Parts List, 5-19
 - Specifications, A-1
 - Start–Up Procedure, 5-1–5-3
 - Status Words
 - STW01, 5-8
 - STW02, 5-9
 - STW06, 4-10, 5-10
 - STW07–STW09, 4-11, 5-11
 - STW10, 5-11
 - STW11–STW18, 5-12
 - Troubleshooting with, 4-10, 5-8–5-13
 - Stop Switch, 2-5
- T**
- Temperature Guidelines, 2-7
 - TISOFT Programming Software, 1-8
 - Troubleshooting
 - AUX Functions and, 5-5–5-7, 5-15
 - EPROM/EEPROM, 4-9–4-11, 5-17
 - LED Indicators and, 5-4
 - P/C, 5-14–5-16
 - Power Supply, 5-18
 - Status Words and, 4-10, 5-8–5-13
- W**
- Wiring Rules, B-4

SIMATIC is a registered trademark of Siemens AG.

Series 500, Series 505, TISOFT1, TISOFT2, TISOFT3, TIWAY, CVU, VPU are trademarks of Siemens Industrial Automation, Inc.

TI505, TI520, TI520C, TI525, TI530, TI530C, TI530T and TI535 are trademarks of Texas Instruments Incorporated.

IBM is a registered trademark of International Business Machines, Incorporated.

DEC is a registered trademark and VAX is a trademark of Digital Equipment Corporation.

Customer Registration

We would like to know what you think about our user manuals so that we can serve you better.
How would you rate the quality of our manuals?

	Excellent	Good	Fair	Poor
Accuracy	_____	_____	_____	_____
Organization	_____	_____	_____	_____
Clarity	_____	_____	_____	_____
Completeness	_____	_____	_____	_____
Overall design	_____	_____	_____	_____
Size	_____	_____	_____	_____
Index	_____	_____	_____	_____

Would you be interested in giving us more detailed comments about our manuals?

Yes! Please send me a questionnaire.

No. Thanks anyway.

Your Name: _____

Title: _____

Telephone Number: (____) _____

Company Name: _____

Company Address: _____

Manual Name: SIMATIC TI505/TI535 Hardware and Installation User Manual

Edition: Thrid

Manual Assembly Number: 2586546-0052

Date: 04/93

Order Number: PPX:505-8103-3

FOLD

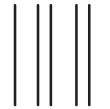

NO POSTAGE
NECESSARY
IF MAILED
IN THE
UNITED STATES

BUSINESS REPLY MAIL

FIRST CLASS PERMIT NO.3 JOHNSON CITY, TN

POSTAGE WILL BE PAID BY ADDRESSEE

SIEMENS INDUSTRIAL AUTOMATION, INC.
3000 BILL GARLAND RD.
P.O. BOX 1255
JOHNSON CITY TN 37605-1255

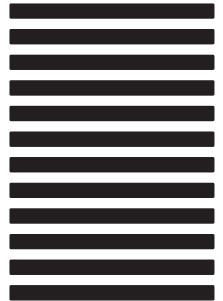

ATTN: Technical Communications M/S 3519

FOLD