

SIEMENS



Industrial Controls

Load Feeders and Motor Starters

SIRIUS Motor Starter M200D AS-Interface Standard

Manual

Edition

08/2014

Answers for industry.

SIEMENS

Industrial Controls

SIRIUS motor starters M200D AS-Interface Standard

Manual

Product description	1
Product family	2
Functions	3
Mounting/Connecting	4
Configuring/assigning parameters	5
Commissioning	6
Diagnostics	7
Technical data	8
Appendix	A
Bibliography	B
Correction sheet	C

Legal information

Warning notice system

This manual contains notices you have to observe in order to ensure your personal safety, as well as to prevent damage to property. The notices referring to your personal safety are highlighted in the manual by a safety alert symbol, notices referring only to property damage have no safety alert symbol. These notices shown below are graded according to the degree of danger.

DANGER

indicates that death or severe personal injury **will** result if proper precautions are not taken.

WARNING

indicates that death or severe personal injury **may** result if proper precautions are not taken.

CAUTION

indicates that minor personal injury can result if proper precautions are not taken.

NOTICE

indicates that property damage can result if proper precautions are not taken.

If more than one degree of danger is present, the warning notice representing the highest degree of danger will be used. A notice warning of injury to persons with a safety alert symbol may also include a warning relating to property damage.

Qualified Personnel

The product/system described in this documentation may be operated only by **personnel qualified** for the specific task in accordance with the relevant documentation, in particular its warning notices and safety instructions. Qualified personnel are those who, based on their training and experience, are capable of identifying risks and avoiding potential hazards when working with these products/systems.

Proper use of Siemens products

Note the following:

WARNING

Siemens products may only be used for the applications described in the catalog and in the relevant technical documentation. If products and components from other manufacturers are used, these must be recommended or approved by Siemens. Proper transport, storage, installation, assembly, commissioning, operation and maintenance are required to ensure that the products operate safely and without any problems. The permissible ambient conditions must be complied with. The information in the relevant documentation must be observed.

Trademarks

All names identified by ® are registered trademarks of Siemens AG. The remaining trademarks in this publication may be trademarks whose use by third parties for their own purposes could violate the rights of the owner.

Disclaimer of Liability

We have reviewed the contents of this publication to ensure consistency with the hardware and software described. Since variance cannot be precluded entirely, we cannot guarantee full consistency. However, the information in this publication is reviewed regularly and any necessary corrections are included in subsequent editions.

Table of contents

1	Product description	9
1.1	What are M200D distributed motor starters?	9
1.2	Fieldbus interfaces	11
1.2.1	AS-Interface	11
2	Product family	13
2.1	M200D AS-Interface motor starters	13
2.2	Overview of the device functions	14
2.3	Design concept	16
2.3.1	Operator controls	17
2.3.2	Connections	18
2.3.3	Status indicators	19
2.4	Internal design	19
3	Functions	23
3.1	Overview of the device functions	23
3.2	Introduction	24
3.3	Basic functions / parameters	25
3.3.1	Rated operational current	25
3.3.2	Load type (1-phase/3-phase load)	27
3.3.3	Protection against voltage failure	28
3.3.4	Response to switching element supply voltage cut-off	28
3.4	Fieldbus interface	29
3.4.1	Response to CPU/Master STOP	29
3.4.2	Group diagnostics	29
3.4.3	Wait for "Parameter" startup data set	30
3.5	Motor control	31
3.5.1	Control function reversing starter	31
3.5.2	Control function soft starter	32
3.5.3	Brake output	36
3.6	Motor protection	39
3.6.1	Thermal motor model	39
3.6.2	Temperature sensor	44
3.7	System monitoring	47
3.7.1	Current limits	47
3.7.2	Asymmetry monitoring	51
3.7.3	Inputs	52
3.7.4	Outputs	60
3.7.5	Connector monitoring	62
3.7.5.1	Motor connector	63

3.8	Short-circuit protection (circuit breaker/disconnecting means)	64
3.9	Communication	65
3.9.1	Communication paths	66
3.9.1.1	Communication path - Process image	66
3.9.1.2	Communication path - Diagnostics	67
3.9.1.3	Communication path - Extended process image	68
3.9.1.4	Communication path - Parameter bits	69
3.9.2	Mode monitoring	70
3.9.3	Commands	72
3.9.4	Data plausibility check	73
3.9.5	Messages output	74
3.10	Logbook	75
3.11	Emergency start	76
3.12	Trip reset	77
3.13	Self-test	77
3.14	Factory settings	78
3.15	Main power monitoring	80
3.16	Electronic/mechanical switching	81
3.17	Cold run	82
3.18	Local device interface	83
3.19	Integrated manual local control	84
4	Mounting/Connecting	87
4.1	Mounting	87
4.1.1	Installation rules	87
4.1.2	Derating	88
4.1.3	Installing the protection guards	92
4.1.4	Installing the motor starter	93
4.1.5	Connecting to functional ground	93
4.1.6	Setting the AS-i address	94
4.1.7	Addressing the motor starter	96
4.2	Connecting	97
4.2.1	Solution Partner	97
4.2.2	Required components/cables	97
4.2.3	Prefabricating power cables	98
4.2.4	Installing and wiring power connectors	99
4.2.5	Power terminal	100
4.2.6	Brake output	102
4.2.7	Inputs/outputs	104
4.2.7.1	Digital inputs IN1 to IN4 (A coding)	104
4.2.7.2	Digital output OUT1 (A coding)	105
4.2.8	AS-Interface	106
4.2.9	Connection options for AS-Interface	106

5	Configuring/assigning parameters	109
5.1	Configuring.....	109
5.2	AS-i profiles.....	109
5.2.1	ID1 code.....	110
5.3	Configuring on the DP/AS-i Link Advanced	110
5.4	Assigning parameters	115
5.4.1	Assigning parameters using AS-i parameter bits	115
5.4.2	Parameter overview	116
5.5	Process data and process image	120
5.5.1	Process image	120
5.5.2	Extended cyclic process image via CTT2.....	123
5.6	Motor Starter ES software	125
6	Commissioning	127
6.1	Requirements.....	127
6.2	M200D components.....	129
6.3	Procedure	130
7	Diagnostics	131
7.1	Diagnostics with LEDs	132
7.1.1	Statuses of the individual LEDs	132
7.1.2	LED display combinations	135
7.2	Diagnostics via parameter channel (parameter echo).....	137
7.3	Sample program	139
7.4	Diagnostics with the addressing and diagnostics unit	140
7.5	Troubleshooting	141
7.5.1	Response to faults	141
7.5.2	Acknowledging faults	142
8	Technical data	143
8.1	General technical specifications	143
8.2	Motor starters.....	144
8.3	Brake control.....	146
8.4	Inputs	146
8.5	Output	147
8.6	Thermistor motor protection.....	147
8.7	Switching frequency.....	148
8.8	Electrical service life of contactor	156
8.9	Dimension drawing	158

A	Appendix	159
A.1	Acyclic data transfer via CTT2	159
A.1.1	Structure of the transfer protocol	160
A.1.2	Writing CTT2 data sets	161
A.1.3	Reading CTT2 data sets	163
A.1.4	Error codes with negative data set acknowledgment	166
A.2	Data formats and data sets	168
A.2.1	Data formats	168
A.2.2	Data sets	171
A.2.2.1	Writing data set 93 (commands)	172
A.2.2.2	Reading data set 200 (device diagnostics)	173
A.2.2.3	Reading data set 201 (measured values)	175
A.2.2.4	Reading data set 202 (statistical data)	175
A.2.2.5	Reading/writing data set 203 (device parameters)	176
A.3	Order numbers	179
A.3.1	M200D AS-i order numbers	179
A.3.2	M200D AS-i Standard motor starters	180
A.3.3	Spare parts/accessories	181
B	Bibliography	185
C	Correction sheet	187
	Glossary	189
	Index	193

Product description

1.1 What are M200D distributed motor starters?

M200D motor starters are standalone devices with a high degree of protection (IP65) for distributed use near the motor.

Depending on the order variant, they are available as:

- Direct starters, electromechanical (DSte) or electronic (sDSte)
- Reversing starters, electromechanical (RSte) or electronic (sRSte)
- Direct soft starters, electronic (sDSSSte)
- Reversing soft starters, electronic (sRSSSte)

They are suitable for the following tasks:

- Switching and protecting three-phase loads at 400 V AC up to 5.5 kW
- Controlling via
 - PROFINET IO
 - PROFIBUS DP or
 - AS-Interface

Depending on the order variant, they are equipped with:

- Brake output for 400 / 230 V AC or 180 V DC
- Integrated manual local control with a key-operated switch and keypad (order variant)

Integration of the motor starter into PROFINET, PROFIBUS and AS-Interface

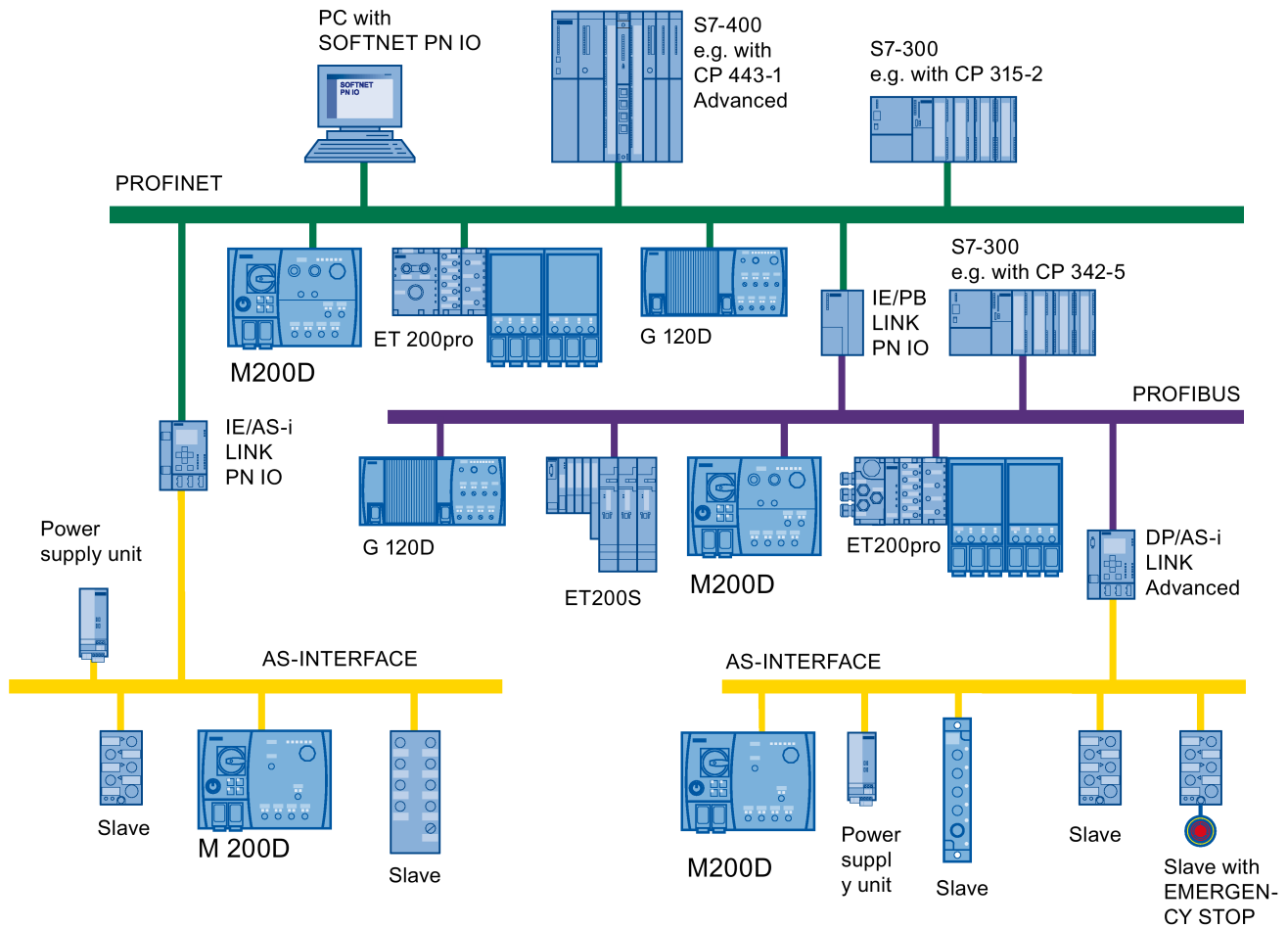

Figure 1-1 Possible fields of application of the M200D motor starter

Motor starter manuals

The following manuals are available for M200D motor starters:

- M200D PROFIBUS/PROFINET Motor Starters
This manual describes M200D motor starters controlled via PROFIBUS DP or PROFINET IO.
- M200D AS-Interface Basic Motor Starters
This manual describes M200D motor starters controlled via the AS-interface, with parameter assignment at the device.
- M200D AS-Interface Standard Motor Starters
This manual (the one you are currently reading) describes M200D motor starters controlled via the AS-interface, with parameter assignment by means of software.

1.2 Fieldbus interfaces

1.2.1 AS-Interface

Overview

The AS-Interface (actuator sensor interface, AS-i) is an open international standard for fieldbus communication between distributed actuators and sensors at the lowest control level.

AS-i complies with the IEC 61158 / EN 50295 standards and was specifically designed for connecting binary sensors and actuators that comply with these standards. AS-i makes it possible to replace point-to-point cabling of the sensors and actuators by a bus line.

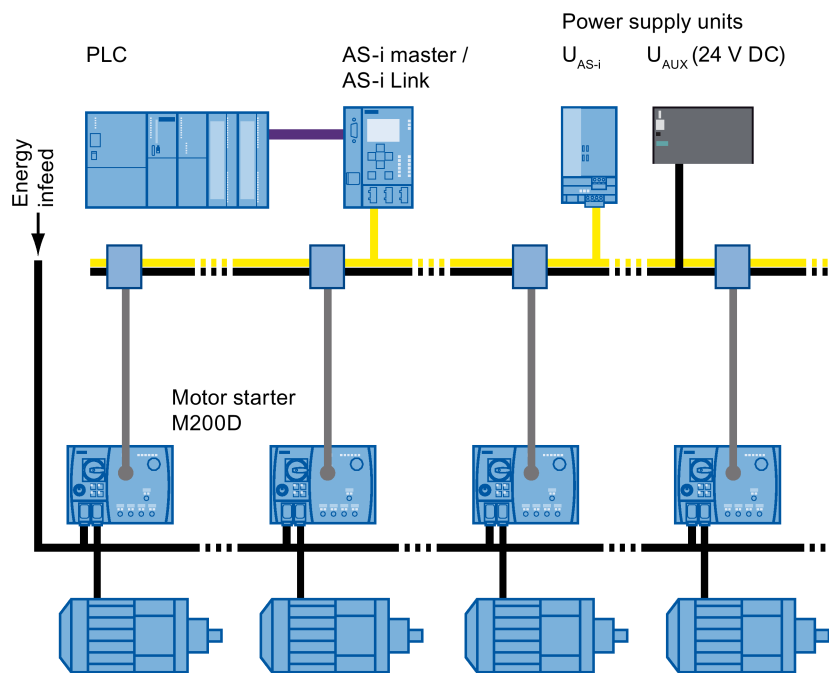

Figure 1-2 Example: M200D AS-i

The AS-Interface has the following advantages:

- Flexibility
- Cost effectiveness
- Simple and rapid installation with a minimum of errors
- A common line for transferring data and power

Product family

2.1 M200D AS-Interface motor starters

The following motor starters with AS-Interface (AS-i) are available:

- M200D AS-i BASIC (parameter assignment at the device)
Motor starter with thermistor motor protection + thermal motor model:
 - Direct starter, electromechanical (DSte), up to 5.5 kW
 - Reversing starter, electromechanical (RSte), up to 5.5 kW
Current range: 0.15 – 2 A and 1.5 – 12 A
 - Direct starter, electronic (sDSte), up to 4 kW (without soft start function)
 - Reversing starter, electronic (sRSte), up to 4 kW (without soft start function)
Current range: 0.15 – 2 A and 1.5 – 9 A
 For a description, please refer to the M200D AS-Interface Basic Motor Starters (<http://support.automation.siemens.com/WW/view/de/35016496>) Manual.
- M200D AS-i STANDARD (parameter assignment via AS-i protocol or Motor Starter ES)
Motor starter with thermistor motor protection + thermal motor model:
 - Direct starter, electromechanical (DSte), up to 5.5 kW
 - Reversing starter, electromechanical (RSte), up to 5.5 kW
Current range: 0.15 – 2 A and 1.5 – 12 A
 - Direct soft starter, electronic (sDSSSte), up to 5.5 kW
 - Reversing soft starter, electronic (sRSSSte), up to 5.5 kW
Current range: 0.15 – 2 A and 1.5 – 12 A

Order variants:

- Brake output for:
 - 400/230 V AC
 - 180 V DC
- Integrated manual local control (key-operated switch and keypad)

Accessories:

- Connection components (e.g. cables, connectors, etc.)
- Safety bar for the plug connections
- Hand-held device
- 'Motor Starter ES 2007' diagnostics and commissioning tool

Order numbers: Motor starters (Page 180), accessories (Page 181)

2.2 Overview of the device functions

Differences between Basic and Standard starters

Device functions	M200D AS-i Basic	M200D AS-i Standard	
	Electromech./electronic (DSte, RSte/sDSte, sRSte)	Electromech. (DSte, RSte)	Electronic (sDSSSte, sRSSSte)
Fieldbus interface	•	•	•
Control function reversing starter	○	○	○
Control function soft starter	—	—	•
400 V/230 V AC brake output	○	○	○
180 V DC brake output	○	○	○
Thermal motor model	•	•	•
Temperature sensor (thermistor motor protection)	•	•	•
Current limit monitoring	—	•	•
Asymmetry monitoring	•	•	•
Blocking protection	•	•	•
Residual current monitoring	•	•	•
M12 inputs (routed via AS-i) Input action can be parameterized	4 (2) —	4 (4) •	4 (4) •
M12 outputs (routed via AS-i) Output action can be parameterized	1 (0) —	1 (1) •	1 (1) •
Connector monitoring	•	•	•
Short-circuit protection	•	•	•
Communication			
Slave type	A/B slave (4I/3O)	A/B slave (4I/3O) and A/B slave (2I/1O) ¹⁾	
Communication profile	7.A.E	7.A.E & 7.A.5	7.A.E & 7.A.5
Diagnostics via parameter channel (parameter echo)	•	•	•
Support for AS-i S1 status bit	•	•	•
Transfer of data sets via AS-i	—	•	•
Extended cyclic process image	—	•	•
Logbook	—	•	•
Access via "Motor Starter ES"	—	•	•

Device functions	M200D AS-i Basic	M200D AS-i Standard	
	Electromech./electronic (DSte, RSte/sDSte, sRSte)	Electromech. (DSte, RSte)	Electronic (sDSSSte, sRSSSte)
Additional functions			
Emergency start	•	•	•
Self-test	•	•	•
Factory settings	•	•	•
Main power monitoring	—	—	•
Cold run	—	•	•
Local device interface	•	•	•
Disconnecting means	•	•	•
Integrated manual local control (key-operated switch, keypad with LEDs)	○	○	○
Setting elements for parameter assignment on device	•	—	—

• Integrated

○ Order variant

1) M200D AS-i Standard has two AS-i slaves and therefore occupies two AS-i addresses.

2.3 Design concept

Connections and controls on the motor starter

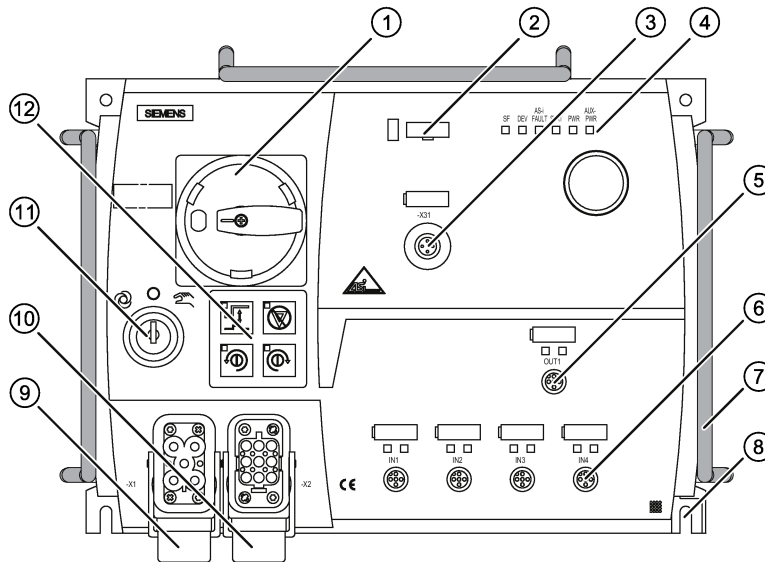

- ① Disconnecting means (circuit breaker), can be locked
- ② Optical device interface
- ③ M12 AS-i connection
- ④ Diagnostic LEDs
- ⑤ 1 digital output M12
- ⑥ 4 digital inputs M12
- ⑦ Up to 3 safety bars for cables and connections (accessories)
- ⑧ 4 fixing holes for mounting (at the right, below the FE connection)
- ⑨ 400 V incoming supply (HAN Q4/2)
- ⑩ Motor connection (HAN Q8/0)
- ⑪ Key-operated switch (order variant)
- ⑫ Keypad for manual local control (order variant)

2.3.1 Operator controls

The motor starter is equipped with the following operator controls:

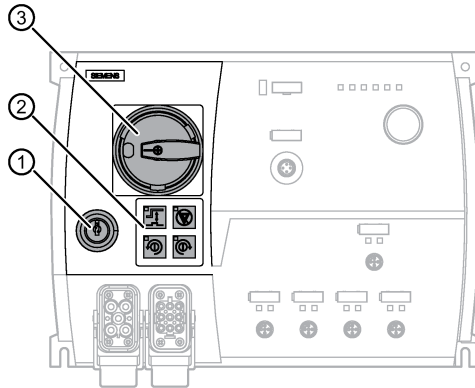

- ① Key-operated switch (order variant)
- ② Keypad for manual local control (order variant)
- ③ Disconnecting means (circuit breaker)

Integrated manual local control (key-operated switch ① and keypad ②; order variant)

A key-operated switch and keypad are used for local operation.
The key can be inserted/removed in 3 positions.

Disconnecting means ③ (circuit breaker)

The disconnecting means is designed for the following individual functions:

- Disconnecting the series-connected loads from the line voltage
- Short-circuit protection of the series-connected load
- Switching on inhibited via padlock (max. 3 padlocks may be used)
- Trip reset in the event of a restart
- Restoration of factory settings, see Factory settings (Page 78)

2.3.2 Connections

Power connections

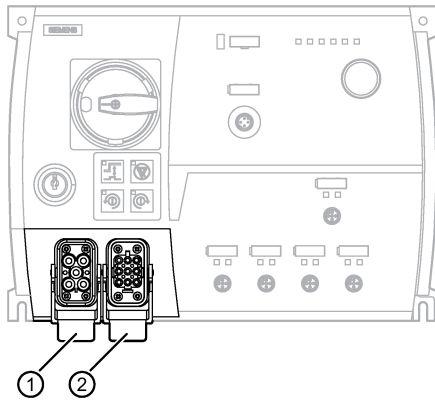

- ① Infeed for the 3 phases as well as the PE and N conductor via power connectors (HAN Q4/2 with ISO 23570 assignment)
- ② Connection of the motor via power connectors (HAN Q8/0)

Control circuits

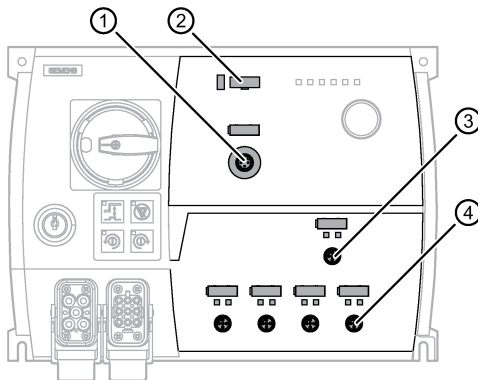

- ① AS-i connection with auxiliary voltage, M12 connector
- ② Optical device interface (under the labeling strip) for connecting HMI components:
 - Hand-held device (can be ordered separately)
 - PC
- ③ 1 digital output M12
- ④ 4 digital inputs M12
 - All inputs can be read via AS-i
 - Input functions can be parameterized

2.3.3 Status indicators

The following LEDs on the front of the starter indicate the device status:

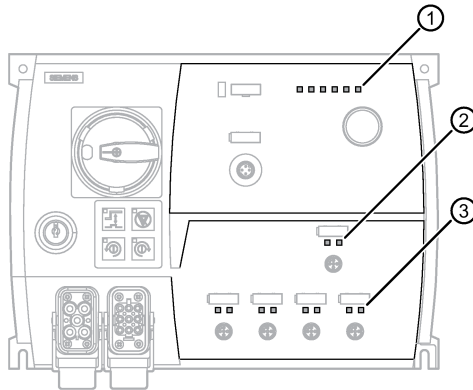

- ① Indicators for the device status and communication
- ② Indicator for output OUT1
- ③ Indicators for inputs IN1 ... IN4

At the inputs and outputs, only the right LED is active.

For a detailed description of the indicators, refer to Diagnostics (Page 132).

2.4 Internal design

The M200D AS-i Standard motor starter contains two separate logical AS-i slaves referred to in the sections that follow as Slave 1 and Slave 2.

The names "Slave 1" and "Slave 2" are not taken from the AS-i standard, but instead have been consciously selected in order to distinguish them from "A/B slave".

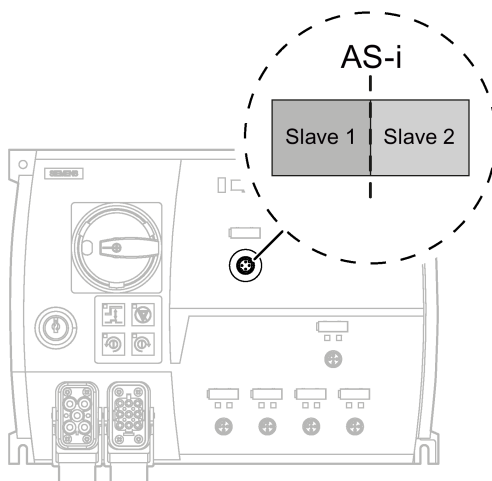

Addressing the M200D AS-i STANDARD motor starter

Slave 1 and Slave 2 occupy two AS-i addresses, such as 1A and 2A or 1A and 1B.

In this way, A/B technology can be used to control up to 31 M200D AS-i STANDARD motor starters in a single AS-i segment.

- If only A addresses are assigned, the cycle time is a maximum of 5 ms.
- If both A and B addresses are assigned, the cycle time is a maximum of 10 ms.

Assigning data to the slave

The cyclic process image PII/PIO is distributed among both slaves (slave 1 and slave 2).

Slave 1 data exchange	Slave 2 data exchange
Cyclic process image	Cyclic process image
Acyclic data sets	—
Extended process image	—
—	Parameter echo (read out diagnostics via parameter channel)

For explanatory information, please refer to Process data and process image (Page 120)

Explanation of terms

Diagnostics via parameter channel (parameter echo)

The "Write Parameter" AS-i command is used to transfer 4 parameter bits to the slave. In the response frame, the slave returns 4 bits (16 bit combinations) of status information.

Process image

Every time the slave is called, 4 bits of control data (PIO) are transferred to the slave on the M200D AS-i STANDARD motor starter. The slave responds with 6 bits of information (PII) in the slave response. The bits are transferred at least every 10 ms (AS-i cycle), depending on what addresses have been assigned.

Note

In the AS-i system, these bits are also referred to as binary data.

CTT2 transfer (Combined Transaction Type 2)

Serial data transfer is set up between the AS-i master and slave (Clock In/Out, Data In/Out). This channel is used to transfer the data sets and extended process image. For an explanation, see Extended cyclic process image via CTT2 (Page 123).

Extended cyclic process image:

CTT2 transfer is used for continually transferring 4 bytes between the AS-i master and slave, in both directions.

Note

In the AS-i system, this generally involves analog data; however, the term "transparent data" is more accurate for the M200D.

Data set transfer:

CTT2 transfer is used for transferring data sets between the AS-i master and slave. The data sets are only transferred when triggered to do so. While (acyclic) data set transfer is in progress, (cyclic) transfer of the extended process image is interrupted.

Functions

3.1 Overview of the device functions

Device functions for the M200D AS-i Standard starter	Electromech. (DSte, RSte)	Electronic (sDSSSte, sRSSSte)
Fieldbus interface (Page 29)	•	•
Control function reversing starter (Page 31)	○	○
Control function soft starter (Page 32)	—	•
400 V/230 V AC brake output (Page 36)	○	○
180 V DC brake output (Page 36)	○	○
Thermal motor model (Page 39)	•	•
Temperature sensor (thermistor motor protection) (Page 44)	•	•
Current limit monitoring (Page 47)	•	•
Asymmetry monitoring (Page 51)	•	•
Blocking protection (Page 47)	•	•
Residual current monitoring (Page 47)	•	•
M12 inputs (routed via AS-i) (Page 52) Input action can be parameterized	4 (4) •	4 (4) •
M12 outputs (routed via AS-i) (Page 60) Output action can be parameterized	1 (1) •	1 (1) •
Connector monitoring (Page 62)	•	•
Short-circuit protection (Page 64)	•	•
Disconnecting means (Page 64)	•	•
Communication		
Slave type	A/B slave (4I/3O) and A/B slave (2I/1O) ¹⁾	
Communication profile	7.A.E & 7.A.5	7.A.E & 7.A.5
Diagnostics via parameter channel (parameter echo) (Page 137)	•	•
Support for AS-i S1 status bit (Page 137)	•	•
Transfer of data sets via AS-i	•	•
Extended cyclic process image (Page 123)	•	•
Logbook (Page 75)	•	•
Access via "Motor Starter ES" (Page 125)	•	•

Device functions for the M200D AS-i Standard starter	Electromech. (DSte, RSte)	Electronic (sDSSSte, sRSSte)
Additional functions		
Emergency start (Page 76)	•	•
Self-test (Page 77)	•	•
Factory settings (Page 78)	•	•
Main power monitoring (Page 80)	—	•
Cold run (Page 82)	•	•
Local device interface (Page 83)	•	•
Integrated manual local control (key-operated switch, keypad with LEDs)	○	○
Setting elements for parameter assignment on device	—	—

• Integrated

○ Order variant

1) The AS-i Standard starter has two AS-i slaves and therefore occupies two AS-i addresses.

3.2 Introduction

Device function

This section describes the device functions. All the device functions are assigned inputs (e.g. device parameters) and outputs (e.g. messages).

The following schematic diagram illustrates the functional principle of the device:

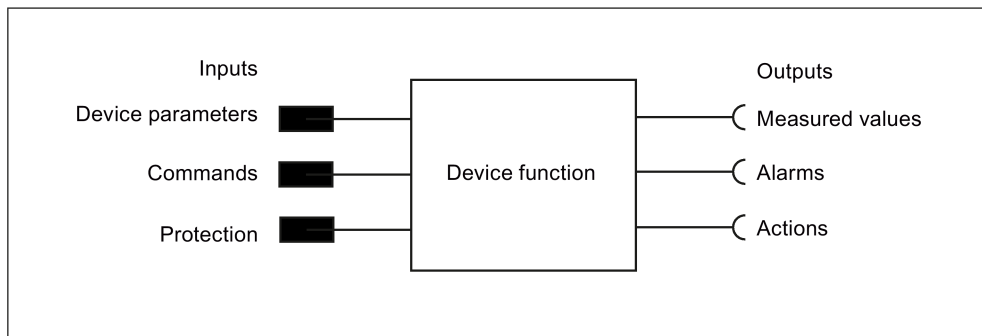

Figure 3-1 Functional principle of the device

Further details regarding device parameters and their change options can be found in the chapter entitled Parameterizing (Page 115)

Self-protection

The motor protects itself against fatal damage by means of the thermal motor model and temperature measurements for electronic switching elements. If the self-protection responds,

- the motor and the brake output are switched off immediately!
- the "switching element overload" signal is generated.

Switching on with "emergency start" is not possible.

Currents

Note

All current values (e.g. blocking current, current limit values) are percentages of the rated operating current set on the device (e.g. $I_e = 2 \text{ A} = 100\%$).

3.3 Basic functions / parameters

Definition

Basic parameters are "central" parameters required by a range of device functions.

3.3.1 Rated operational current

Here, you can enter the rated operating current that the branch (switchgear and motor) can carry without interruption. This is usually the rated motor current. The setting range depends on the output class of the M200D motor starter (0.15 ... 2 A or 1.5 ... 12 A).

Note

The rated operating current is one of the key parameters.

The rated operating current must **always** be set if motor protection is to be ensured via the electronic overload relay.

The overload relay can be deactivated.

In this case, motor protection must be ensured by means of a thermistor in the motor.

Instructions

- In the M200D AS-i Standard motor starter, the rated operational current is preset at the factory to the **maximum** value. (For testing at startup without fieldbus and without previous parameterization)

Note

If the parameter bits of slave 1 are not changed during AS-i parameter assignment and no parameters are sent to the starter via process image or data set, the motor current is set to the highest value. This means that there may not be any overload protection.

- In the "Motor Starter ES" software, the rated operational current is preset to the **minimum** value for safety reasons. You must therefore parameterize this value when you configure the system. Otherwise the motor starter would trip when it starts for the first time due to overloading.
- The rated operational current depends on the "startup mode" parameter on motor starters with soft starter function. If the startup mode is set as "direct", the choice of rated operational current is restricted to 9 A.

Settings

Device parameter	Default setting	Setting range
Rated operational current	<ul style="list-style-type: none"> • In the motor starter: Maximum value • In Motor Starter ES: Minimum value 	<ul style="list-style-type: none"> • 0.15 A to 2.0 A • 1.5 A to 9.0 A ¹⁾ • 1.5 A to 12.0 A Increment: 10 mA
¹⁾ On soft starters (sDSSSte, sRSSSte) in "direct" startup mode		

Note

The setting range depends on the device type!

3.3.2 Load type (1-phase/3-phase load)

Here, you can specify whether the motor starter must protect a single-phase or a three-phase load.

- Asymmetry detection is deactivated in the case of a single-phase load, such as a single-phase AC motor!
The single-phase load can be connected between any two paths of the motor starter for all mechanically switched motor starters.
- Asymmetry detection is activated for three-phase loads such as three-phase asynchronous motors. The three phase currents are compared to one another.

Note

The load type is only relevant for mechanical motor starters. Only 3-phase load types may be connected to electronic starters.

Note

Only one motor must be connected to a motor starter, otherwise motor protection can no longer be guaranteed.

Settings

Device parameter	Default setting	Setting range
Load type	3-phase	<ul style="list-style-type: none"> • 3-phase • 1-phase

Note

This parameter can only be set using Motor Starter ES.

3.3.3 Protection against voltage failure

You use this device parameter to specify whether or not the overload message must be retained after an electronics voltage failure:

- Overload
- No overload

Settings

Device parameter	Default setting	Setting range
Protection against voltage failure	Yes	<ul style="list-style-type: none">• Yes• No

Note

This parameter can only be set using Motor Starter ES.

3.3.4 Response to switching element supply voltage cut-off

With this parameter, you determine which message the motor starter is to output if the supply voltage of the switching elements fails.

Settings

Device parameter	Default setting	Setting range
Response to switching element supply voltage cut-off	Group fault	<ul style="list-style-type: none">• Group fault• Group fault only after ON command• Group warning

3.4 Fieldbus interface

3.4.1 Response to CPU/Master STOP

This device parameter enables you to specify how the motor starter is to respond to CPU/Master STOP:

- Retain last value:
The PIO is retained.
- Switch substitute value:
Substitute value = 0

Note

This is only relevant in "automatic" mode.

Settings

Device parameter	Default setting	Setting range
Response to CPU/Master STOP	Switch substitute value	<ul style="list-style-type: none"> • Switch substitute value • Retain last value

Messages and actions

Message	Action
CPU/master STOP	Dependent on parameterization
Bus error	"Response to CPU/master STOP" depending on parameterization

3.4.2 Group diagnostics

You use this parameter to specify whether diagnostics via the fieldbus interface is to be enabled or disabled. If group diagnostics is parameterized as "block", no error messages are transmitted.

The controller is informed of whether or not a group fault message is present in the device when "I/O fault bits" on the SAP status tab (S1 = 1) is set. The AS-i master enters the S1 value in the list of I/O faults (LPF) that have been signaled. The controller can read this list via the "GET_LPF" command and then query a specific diagnostic value from the slave (see also Diagnostics via parameter channel (parameter echo) (Page 137)).

The motor starter issues a fault message if a fault is present. In this case, the SF LED lights up red.

Reference

For more information, refer to the documentation for your AS-i master.

Settings

Device parameter	Default setting	Setting range
Group diagnostics	enable	<ul style="list-style-type: none">• block• enable

3.4.3 Wait for "Parameter" startup data set

The user sets this parameter bit during configuration using STEP 7. It tells the motor starter if a data set will be transferred. The motor starter waits for the "Parameter" startup data set for 3 minutes. If the transfer is not completed within this time, the starter signals the "Invalid parameter value" fault. This fault is automatically acknowledged if the startup parameters have been transferred without problems.

For more information, see Configuring/assigning parameters (Page 109).

Settings

Device parameter	Default setting	Setting range
Wait for "Parameter" startup data set	No	<ul style="list-style-type: none">• Yes• No

Note

This parameter can only be set using an AS-i parameter bit.

3.5 Motor control

3.5.1 Control function reversing starter

Description

This control function allows the motor starter to control the direction in which motors rotate. Simultaneous activation of both directions of rotation is prevented by the internal logic. Delayed switching from one direction of rotation to the other is implemented by means of the lock-out time.

Note

To reverse the direction of rotation, a mechanically-switching reversing contactor is integrated in reversing starters with electronic switching. The preferred position of this contactor after power-up is "CW rotation". When the direction is changed to "CCW rotation", the reversing contactor is activated first, followed by the electronic contacts after an 80 ms delay.

Lock-out time

The lock-out time results in delayed switching of the direction of rotation. The rotating mass of a drive must come to a standstill during the lock-out time before the next switching command can be executed.

Note

A lock-out time set to 0 is set internally to 150 ms for safety purposes.

Settings

Device parameter	Default setting	Setting range
Lock-out time	0	0 to 60 s Increment: 1 s

Note

This parameter can only be set using Motor Starter ES.

Messages and actions

Message	Action
Motor CCW	Motor runs with CCW rotation.
Lock-out time active	ON command suppressed in opposite direction.

3.5.2 Control function soft starter

Description

Soft starters function according to the phase angle control principle. You can specify soft starting and soft run-down using a settable voltage ramp. This function only applies to soft starters.

The figure below illustrates the principle:

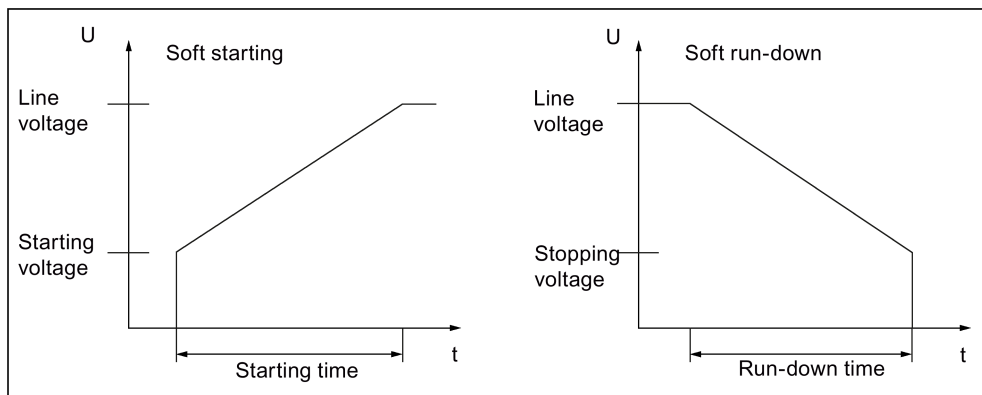

Figure 3-2 Soft starting/soft run-down principle

Termination of soft run-down (regenerative run-down)

Note

Soft run-down is only meaningful if the motor does not run down regeneratively (moving load). If soft run-down is nevertheless activated via parameterization, the motor starter terminates soft run-down and switches the motor off. The brake output is switched off depending on the set parameters.

Soft run-down on motor starters with mechanical braking

In parallel with soft run-down, motor starters with mechanical braking offer the following control options with the parameter "brake holding time on stopping":

- Brake holding time on stopping = 0:
Motor voltage V is reduced to the stopping voltage during the run-down time. Following this, the motor voltage and the brake output are switched off simultaneously. When soft run-down is terminated, the motor voltage and the brake output are switched off simultaneously.
- Brake holding time on stopping > 0:
Motor voltage V is reduced to the stopping voltage during the run-down time and switched off. The holding time also runs in parallel with the run-down time. On expiry of the holding time, the brake output is switched off independently of the soft run-down.

The figure below shows the principle of the loaded motor:

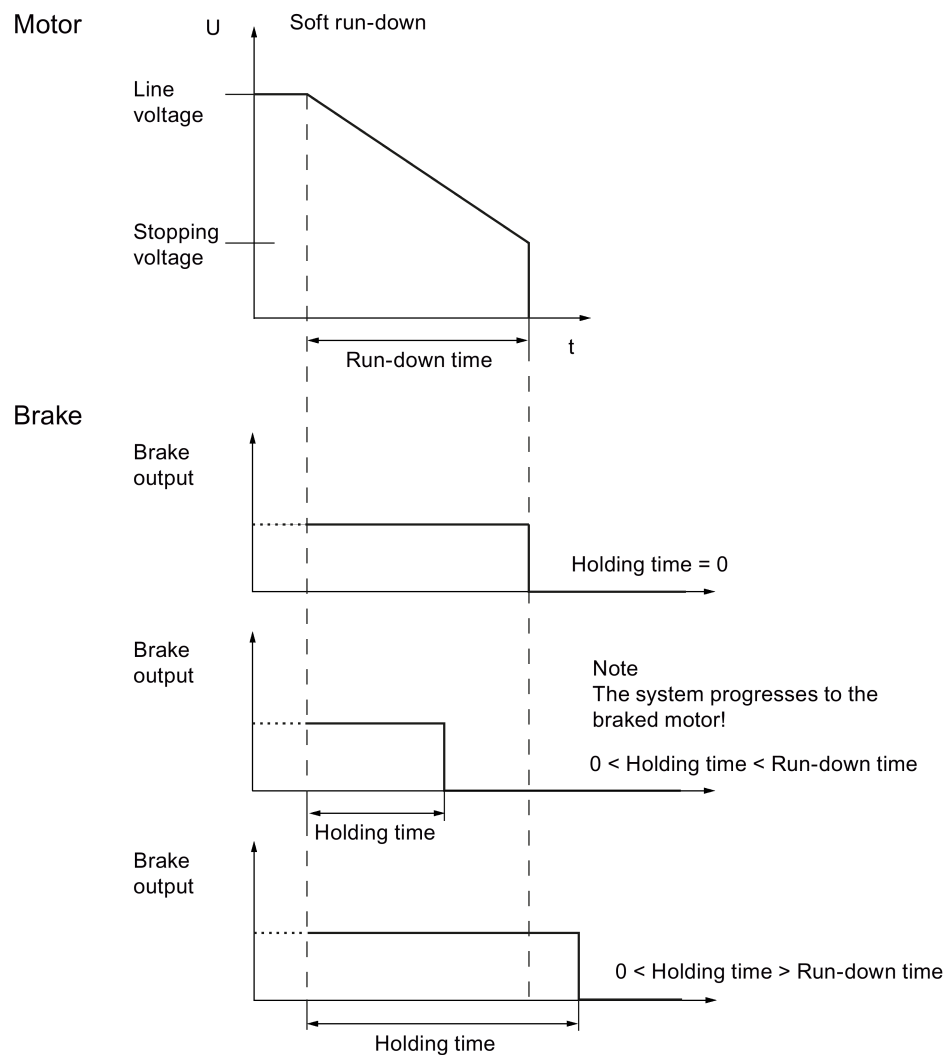

Figure 3-3 Principle of soft run-down on motor starters with mechanical braking

You can find more information on the "Brake holding time on stopping" in the chapter "Mechanical braking".

Start time

During the parameterized starting time, the motor terminal voltage is increased linearly from the starting voltage to the full line voltage. A setting of 0s means that the motor is switched on with a voltage ramp of 100 milliseconds to reduce the peak inrush current.

Run-down time

During the parameterized run-down time, the motor terminal voltage is reduced linearly from the line voltage to the stopping voltage. A setting of 0s means that the motor is switched off directly, without a voltage ramp.

Startup mode

There are four methods of starting the motor:

- Direct: The motor is switched on directly without a voltage ramp or current limitation.
- Voltage ramp: The motor is started up on a linear, positive voltage ramp.
- Current limiting: The inrush current of the motor is limited to a specified value.
- Voltage ramp + current limiting: If the motor current exceeds the specified value at startup, the voltage ramp is aborted and the current is limited.

Note

In the case of "direct" startup mode, you must note the following derating:

- Reduction of the rated operating current from 12 A to 9 A
 - Only CLASS 5 or CLASS 10 possible.
-

Run-down type

There are two methods of running down or stopping the motor:

- Run-down without load: The motor is switched off immediately.
- Voltage ramp: The motor is powered down on a linear, negative voltage ramp.

Starting voltage

The starting voltage is the initial value of the voltage ramp for soft starting. The voltage ramp is started with the appropriate starting voltage and increased linearly to the line voltage.

Stopping voltage

The stopping voltage is the final value of the voltage ramp for soft run-down. The voltage ramp is run to the stopping voltage and then switched off.

Current limit value

With the startup modes "Current limiting" and "Voltage ramp + current limiting", the motor current is limited to a maximum value during starting.

Note

At a rated operating current ≥ 9 A, the motor starter automatically reduces the current limit value to 550%.

Settings

Device parameter	Default setting	Setting range
Starting time	5 s	0 to 30 seconds Increment: 0.25 s
Run-down time	0	0 to 30 s Increment: 0.25 s
Startup mode	direct	<ul style="list-style-type: none"> • direct • Voltage ramp • Current limit • Voltage ramp + current limit
Run-down type	Run-down without load	<ul style="list-style-type: none"> • Run-down without load • Voltage ramp
Starting voltage	40%	20% to 100% Increment: 5%
Stopping voltage	40%	20% to 90% Increment: 5%
Current limit value	<ul style="list-style-type: none"> • 600% ($I_e \leq 9$ A) • 550% ($I_e > 9$ A) 	<ul style="list-style-type: none"> • $I_e \leq 9$ A: 125% to 600% • $I_e > 9$ A: 125% to 550% Increment: 3.125%

Messages and actions

Message	Action
Starting active	The motor is switched on depending on the "Startup mode" parameter.
Run-down active	The motor is switched on depending on the "Run-down mode" parameter.
No supply voltage	ON command generates faults.
Current limiting active	Motor starting current is limited.

3.5.3 Brake output

Description

A motor-mounted mechanical disk or spring-loaded brake is used to brake the motor. The brake is controlled via the brake output.

Typical circuit diagram

The following circuit diagram illustrates the mechanical braking procedure with a 180 V DC brake output:

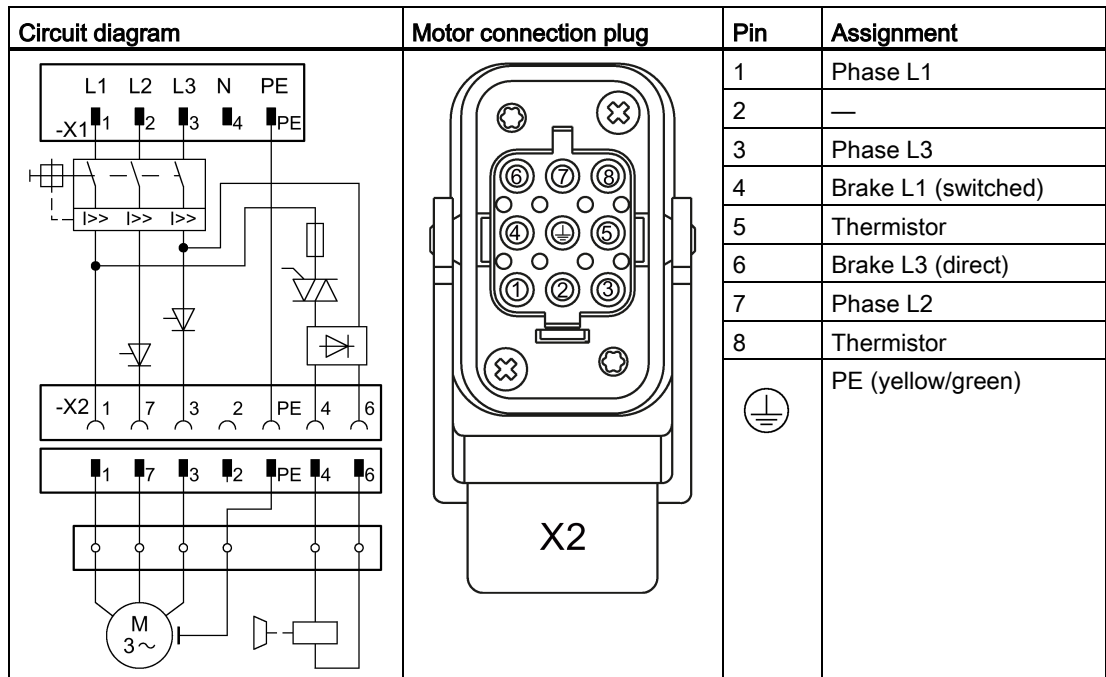

Brake output

<p>⚠ WARNING</p> <p>Hazardous voltage Danger of death or serious injury</p> <p>The brake is only switched in a single phase. This means that voltage may be present at pin 6 even when the system is switched off.</p>
--

Externally supplied motor brakes are usually powered via a jumper on the motor terminal board.

Since switching the motor and brake simultaneously can increase wear and tear to the brake, all M200D motor starters can be fitted with an optional electronic brake controller (order variant).

Depending on the order variant, the following externally supplied brake coils can be controlled:

- 400 V AC/230 V AC
(The brake rectifier must be installed in the motor. The rectifier input is controlled via the motor starter).
- 180 V DC
(A rectifier is not required for the brake in the motor because the motor starter provides the 180 V DC. In this way, brake coils for 180 V DC can be switched directly.)

The brake voltage is fed to the motor together with the motor infeed via a joint cable. For more information about connecting the brake output, see Brake output (Page 102).

Note

With both brake output versions, the electronic switching element is located on the AC side. Please refer to the technical data of the brake (e.g. Catalog D87.1 "SIEMENS MOTOX Geared Motors") for the resulting application time of the brake.

If faster brake application times are required (DC side tripping), a 400 V / 230 V AC brake output in conjunction with a function rectifier integrated into the motor is preferable.

Devices with a 180 V DC brake output as of product version E10 are suitable for achieving fast brake engaging times. This means that the time until the motor comes to a standstill is shorter compared with previous product versions.

The integrated freewheeling diode is deactivated when switching off the brake output and the energy of the brake coil dissipated through a varistor.

Brake release delay on starting

Note

Only active if an ON switching command is present for the brake and the motor **simultaneously**.

Positive times: Delayed switch-on of the brake output compared to the motor.

Negative times: Delayed switch-on of the motor compared to the brake output.

During a reversing operation, the release delay does not begin until the lock-out time has expired.

Brake holding time on stopping

Note

Only active if an OFF switching command is present for the brake and the motor **simultaneously**.

This device parameter causes delayed tripping of the brake output compared to the motor. It also works in the event of a PLC failure.

During a reversing operation, the holding time and the lock-out time run concurrently. Switching on in the opposite direction of rotation is not possible until the lock-out time has expired. Switching on in the same direction is possible immediately in this case because the lock-out time is aborted.

Priority rule

"Brake release delay on starting" takes priority over "brake holding time on stopping". An expiring holding time is terminated if the release delay is restarted (by means of an ON switching command for brake and motor.)

Settings

Device parameter	Default setting	Setting range
Brake release delay on starting	0 s	- 2.5 to + 2.5 s Increment: 0.01 s
Brake holding time on stopping	0 s	0 to 25 s Increment: 0.01 s

Messages and actions

Message	Action
Brake output active	Brake coil is controlled, motor can be rotated.

3.6 Motor protection

3.6.1 Thermal motor model

Description

The approximate temperature of the motor is calculated using the measured motor currents and device parameters "Rated operating current" and "Tripping class". This indicates whether the motor is overloaded or functioning in the normal operating range.

Response to overload - thermal motor model

You use this device parameter to specify how the motor starter is to respond in an overload situation:

- Trip without restart (AUTO RESET = off)

Following an overload situation, the trip command cannot be reset until the motor model has fallen below the reset threshold and a reset command has been issued after this (trip reset).

- Trip with restart (AUTO RESET = on)

Once the cause of the fault has been eliminated (e.g. cooling down following "Temperature sensor overload"), the motor starter automatically acknowledges the fault message (= auto reset).

WARNING

**Motor restarts automatically if AUTO RESET is on.
Can Cause Death, Serious Injury, or Property Damage**

The motor starter restarts automatically after the recovery time if a start command is present (auto reset).

Make sure that you take appropriate measures to exclude the risk of hazardous conditions.

- Warning

Note

If the value of the thermal motor model exceeds the limit of 178% for self-protection of the motor starter, the motor starter itself generates a trip command regardless of the parameter assignment for "Response to overload - thermal motor model".

Trip class

The trip class (CLASS) specifies the maximum time within which a protective device must trip from a cold state at 7.2x the current setting (motor protection to IEC 60947). The tripping characteristics represent this time to disengagement as a function of the tripping current.

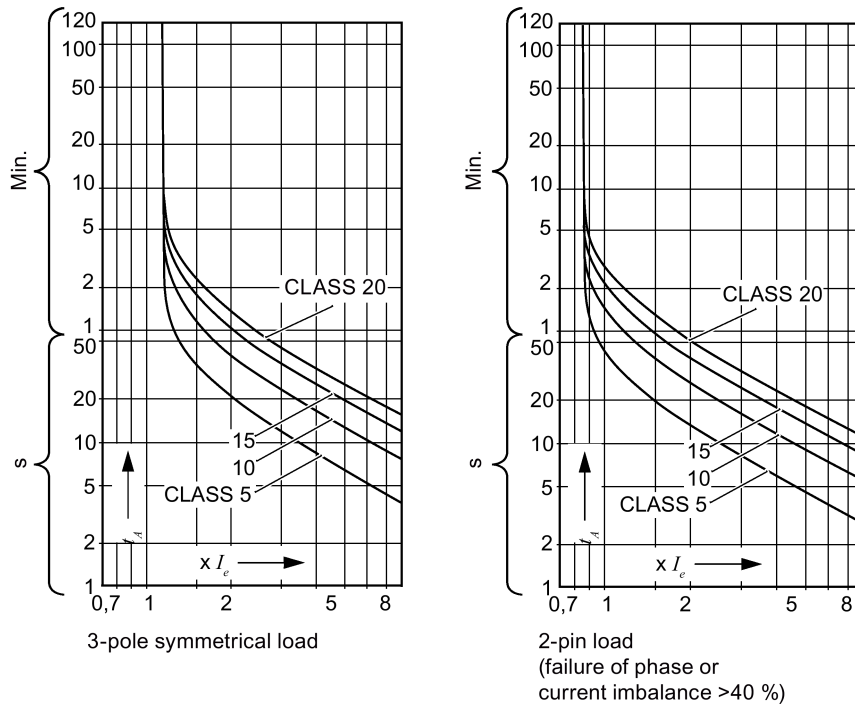

Figure 3-4 Tripping characteristics

Note

The setting options for the trip classes are dependent on the motor starter and the current range.

The following trip classes can be parameterized:

- CLASS 5 (10a)
- CLASS 10
- CLASS 15
- CLASS 20
- CLASS OFF (deactivates the thermal motor model)

Note**Deactivation rule**

To guarantee motor protection, the trip class cannot be deactivated in the event that the temperature sensor is deactivated (= CLASS OFF).

See also Data plausibility check (Page 73).

Note**Parameter dependence of control function soft starter**

If "direct" startup mode is selected for the "Control function soft starter" device parameter, the trip class can only be parameterized to CLASS 5 (10a), CLASS 10 and deactivated by means of CLASS OFF.

Recovery time

The recovery time is the specified cooling time after which the system can be reset following an overload trip.

Trip reset signals present during the recovery time have no effect.

The recovery time following an overload trip is at least 1 minute. The recovery time can be parameterized and modified to between 60 seconds and 1,800 seconds. Voltage losses occurring before this time expires can prolong the recovery time if the "Protection against voltage failure" basic parameter is active.

Motor heating prewarning limit

The motor starter also assumes a prewarning role; that is, it issues a warning if the motor heating limit is exceeded. You use this parameter to preset a motor heating value in percent as a prewarning limit. The motor starter displays a warning if the parameterized motor heating limit is overshot.

This function is deactivated with a motor heating prewarning limit of 0%.

Prewarning limit - remaining time for tripping

You use this parameter to preset a time as a prewarning limit. The motor starter warns against imminent overload tripping within the parameterized time if the present operating conditions are retained. This function is deactivated with a prewarning limit of 0% for the remaining time for tripping.

Idle time

The idle time is the time specified for cooling after tripping under normal operating conditions; that is, not in the case of overload tripping. Once this time has expired, the thermal memory of the motor starter is deleted. A cold restart can be carried out.

This means that, with the drive dimensioning adjusted as appropriate, a higher number of starting operations can be performed without exceeding the trip limit of the motor model.

Note

A higher number of starting operations results in increased motor heating. If the motor dimensioning has not been adapted (temperature class), motor protection is no longer guaranteed.

The diagram below illustrates cooling with and without idle time.

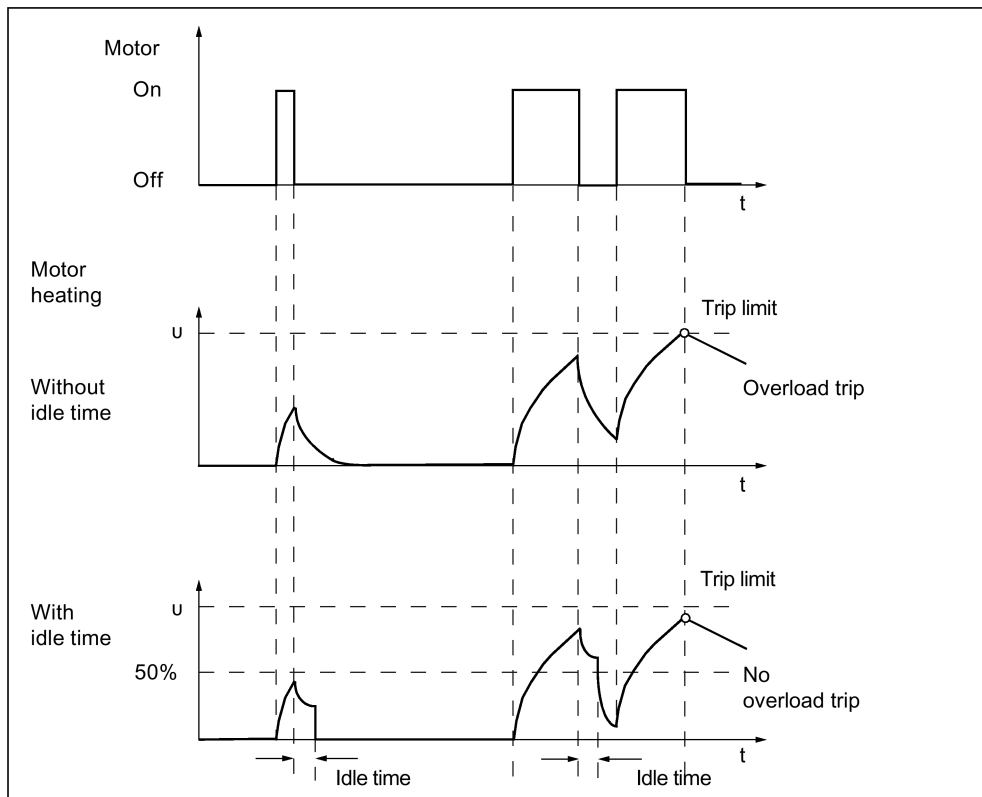

Figure 3-5 Cooling with and without idle time

Note

Motor heating > 50%: After the idle time has expired, the save value of the motor model is reduced to 50%.

Motor heating < 50%: After the idle time has expired, the save value of the motor model is reduced to 0%.

Settings

Device parameter	Default setting	Setting range
Response to overload - thermal motor model	Trip without restart	<ul style="list-style-type: none"> • Trip without restart • Trip with restart • Warning
Trip class	CLASS 10	<ul style="list-style-type: none"> • CLASS 5 (10a) • CLASS 10 • CLASS 15 ¹⁾ • CLASS 20 ¹⁾ • CLASS OFF
Recovery time	90 s	60 to 1,800 s Increment: 30 s
Motor heating prewarning limit	0% (= deactivated)	0 to 95% Increment: 5%
Prewarning limit - remaining time for tripping (Motor Starter ES)	0 s (= deactivated)	0 to 500 s Increment: 1 s
Idle time (Motor Starter ES)	0 s (= deactivated)	0 to 255 s Increment: 1 s

¹⁾ Cannot be parameterized for soft starters with startup mode = direct

Note

Individual parameters can only be set using Motor Starter ES.

Messages and actions

Message	Action
Thermal motor model deactivated	No motor protection via thermal motor model; motor protection required by means of temperature sensor.
Thermal motor model - overload	Dependent on parameterization
Overload tripping	Trip (overload pending)
Idle time active	The motor is reset on expiry of the idle time
Cooling time active	Restart is prevented until the cooling time has expired (recovery time).
Prewarning limit - remaining time for tripping undershot	-
Prewarning limit - motor heating exceeded	-

3.6.2 Temperature sensor

Description

Temperature sensors are used to directly monitor the motor winding temperature. This indicates whether the motor is overloaded or functioning normally. If temperature sensors are installed in the motor stator winding (order option for the motor), the M200D motor starter can use these to monitor the motor.

M200D motor starters can evaluate **one** temperature sensor circuit.

The temperature sensor evaluation electronics are galvanically isolated from the electronics and the auxiliary voltage.

This is beneficial if insulation damage is caused to the motor or the motor supply line, as this does not affect any further system components (see Technical Specifications (Page 147)).

Temperature sensor

You can activate or deactivate this parameter depending on whether or not a temperature sensor is installed in the motor.

Two types of temperature sensor are supported:

- Thermoclick.
This is a switch that opens at a certain winding temperature.
- PTC type A
This is a PTC thermistor with a characteristic to IEC 60947-8.

Note

If you parameterize the temperature sensor as "deactivated", the following parameters are ignored:

- Response to overload temperature sensor
 - Temperature sensor monitoring (with PTC)
-

Response to overload temperature sensor

You use this parameter to specify how the motor starter is to respond in an overload temperature sensor situation:

- Tripping without restart (AUTO RESET = off)
- Tripping with restart (AUTO RESET = on)

 WARNING
--

<p>Motor restarts automatically if AUTO RESET is on. Can Cause Death, Serious Injury, or Property Damage</p>

<p>The motor starter restarts automatically after the recovery time if a start command is present (autoreset).</p>
--

<p>Make sure that you take appropriate measures to exclude the risk of hazardous conditions.</p>
--

- Warning

Temperature sensor monitoring

Temperature sensor monitoring is activated when a PTC type A temperature sensor is parameterized. It is then automatically deactivated if thermoclick is parameterized.

This device parameter monitors the temperature sensor cable for interruptions (wire break) and short circuits. The motor is shut down (depending on the parameterization).

Settings

Device parameter	Default setting	Setting range
Response to temperature sensor overload	Trip without restart	<ul style="list-style-type: none"> • Trip without restart • Trip with restart • Warning
Temperature sensor	Deactivated	<ul style="list-style-type: none"> • Deactivated • Thermoclick • PTC type A
Temperature sensor monitoring (Motor Starter ES)	<ul style="list-style-type: none"> • Yes • No (thermoclick) 	<ul style="list-style-type: none"> • Yes • No

Note

Individual parameters can only be set using Motor Starter ES.

Messages and actions

Message	Action
Temperature sensor - overload	Dependent on parameterization
Temperature sensor wire break	Dependent on parameterization
Temperature sensor short circuit	Dependent on parameterization
Temperature sensor deactivated	No motor protection through temperature sensor; motor protection required by means of motor model.
Overload tripping	Trip (overload, wire break or short circuit pending)

3.7 System monitoring

3.7.1 Current limits

Description

The motor current and current limit values can be used to determine different system statuses:

System status	Current value	Protection by
Motor operates more sluggishly, e.g. because bearings are damaged. Motor operates more smoothly, e.g. because it has run out of processing material.	Current is higher or lower than normal	Current limit values
Motor blocked	Very high current flowing	Blocking protection
Motor runs at no load (e.g. because system is damaged)	Very low current flowing (< 18.75% of I_e)	Residual current detection

Response to residual current detection

Residual current detection responds if the motor current drops below 18.75% of the set rated operational current in all 3 phases.

You use this device parameter to determine how the motor starter is to respond in the case of residual current detection:

- Warning
- Trip

Note

When the motor is switched on, residual current detection is suppressed for around 1 second.

Response to current limit violation

You use this device parameter to specify how the motor starter is to respond in the event of the current limits being violated:

- Warning
- Trip

Upper/lower current limit You can enter an upper and/or lower current limit.

Example:

- "Viscosity of mixed mass is too high"; that is, the upper current limit has been overshoot.
- "No load because drive belt is broken"; that is, the lower current limit has been undershoot.

Note

The current limits are not activated until the class time expires, e.g. after 10 seconds for class 10 (startup override).

If the current limits are overshoot or undershoot, the motor starter responds either by tripping or with a warning.

Note

The current limits can also be deactivated.

Blocking time

The blocking time is the time during which a motor can be blocked without tripping. If the blocking time expires and the block is still in place, the motor starter trips.

Blocking current monitoring

The blocking current specifies how much current is consumed by the motor (at rated voltage) when the axis is blocked.

If the motor current exceeds the parameterized value for the blocking current, the motor starter detects the block. Blocking time monitoring is activated from the point at which the blocking current is exceeded. If the blocking current flows for longer than the parameterized blocking time, the motor starter automatically generates a trip command.

Blocking protection principle in run-up phase:

The figure below shows the principle of blocking protection during the run-up phase; that is, the interaction between the blocking current and blocking time:

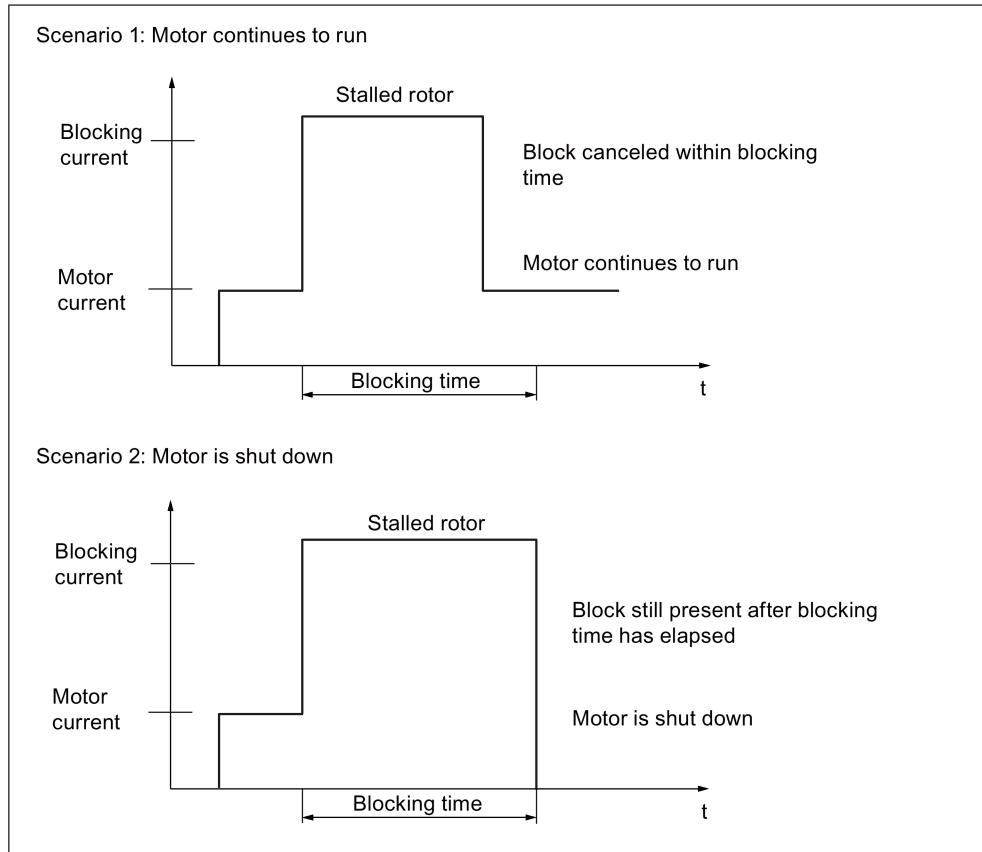

Figure 3-6 Blocking protection principle

Blocking protection principle after run-up phase

Following the run-up phase, blocking protection behaves as follows during uninterrupted duty:

- The blocking time is reduced to 1 s regardless of the parameterized value.
- The blocking current is limited to a maximum of 400%.
With a parameterized blocking current < 400%, the parameter value is valid.
- When the blocking protection responds, the motor starter itself generates a trip command.
- The messages "Tripping due to motor blocking" and "Group fault" are generated.
- The maximum pointer "Number of switch element overload trips" is incremented by 1.

Settings

Device parameter	Default setting	Setting range
Response to residual current detection	Trip	<ul style="list-style-type: none"> • Trip • Warning
Response to current limit violation	Warning	<ul style="list-style-type: none"> • Warning • Trip
Lower current limit	18.75%	<ul style="list-style-type: none"> • 18.75 to 100% of I_e • 0% (= deactivated) Increment: 3.125%
Upper current limit	112.1%	<ul style="list-style-type: none"> • 50 to 400% of I_e • 0% (= deactivated) Increment: 3.125%
Blocking current (Motor Starter ES)	800%	<ul style="list-style-type: none"> • 150 to 1,000% of I_e • 150 to 800% of I_e (sDS..., sRS...) Increment: 50%
Blocking time (Motor Starter ES)	1 s	1 to 5 s Increment: 0.5 s

Note

Individual parameters can only be set using Motor Starter ES.

Messages and actions

Message	Action
I_e upper limit violation	-
I_e lower limit violation	Dependent on parameterization
I_e limit tripping	Trip (limit violation pending)
Residual current detected	Dependent on parameterization
Residual current tripping	Trip (residual current detection)
Tripping due to motor blocking	Trip (blocking protection)

3.7.2 Asymmetry monitoring

Description

Three-phase induction motors respond to slight asymmetries in the supply voltage with a higher asymmetric current consumption, which causes the temperature in the stator and rotor windings to increase. In this case, the M200D motor starter protects the motor against overload by shutting it down.

Note

When the motor is switched on, asymmetry evaluation is suppressed for approx. 0.5 s.

Asymmetry limit

The asymmetry limit is a percentage value by which the motor current is allowed to deviate in each phase.

Asymmetry exists when the difference between the smallest and the greatest phase current is greater than the parameterized asymmetry limit.

The reference value for the analysis is the maximum phase current in one of the 3 phases!

Response to asymmetry

You use this device parameter to specify how the motor starter is to behave in the event of asymmetry:

- Warning
- Trip

Settings

Device parameter	Default setting	Setting range
Response to asymmetry	Trip	<ul style="list-style-type: none"> • Warning • Trip
Asymmetry limit (Motor Starter ES)	30%	<ul style="list-style-type: none"> • 30 to 60% • 0 = deactivated Increment: 10%

Note

Individual parameters can only be set using Motor Starter ES.

Messages and actions

Message	Action
Asymmetry detected	Dependent on parameterization
Asymmetry tripping	Trip (asymmetry exists)

3.7.3 Inputs

Description

Using the "Inputs" device function, the motor starter can carry out different actions that you can parameterize whereby the signals at the digital inputs are evaluated. You can connect the inputs directly to sensors (PNP) (2 and 3-wire system).

The signals of inputs IN1 to IN4 are transferred cyclically via the process image.

The input actions of the individual digital inputs affect the motor starter functions (=OR operation) independently of one another.

Note

The digital output must not be connected to a digital input because this can establish an impermissible connection between the U_{AS-i} and U_{AUX} voltages.

Input function

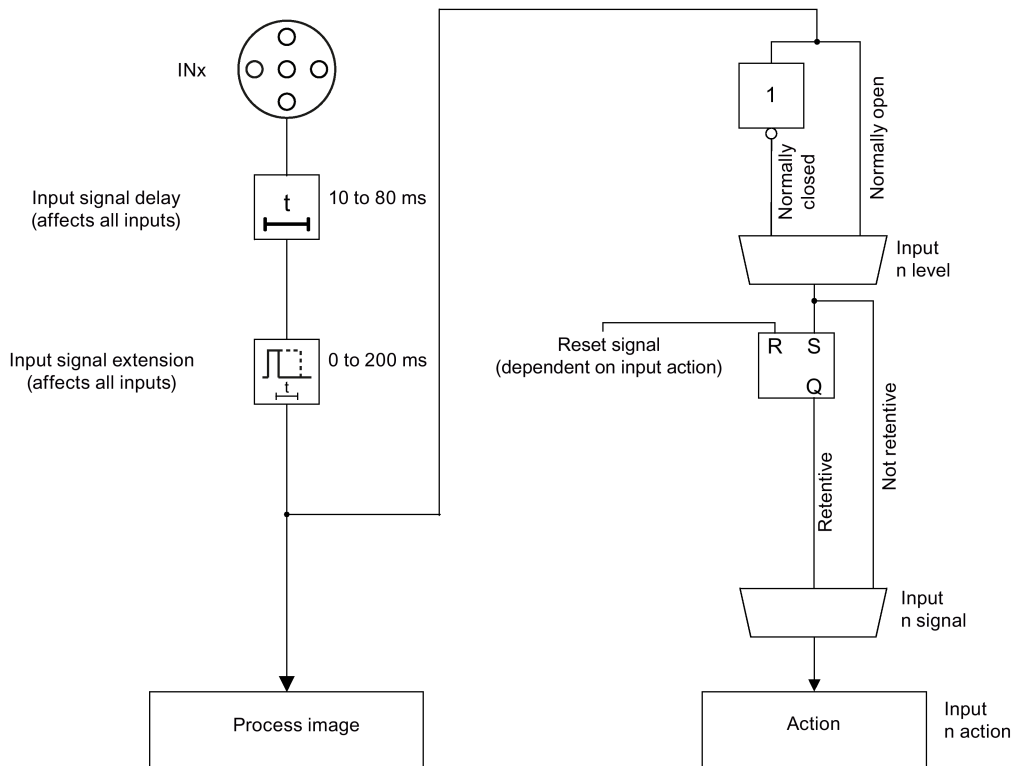

Figure 3-7 Overview of input parameters

Input signal extension

A short input signal can be extended compared to the actual input signal with the help of this parameter. This enables reliable transfer to the controller (compensation of bus transfer times and processing time in the controller).

Input signal delay

You can set a debounce time for the inputs in order to achieve interference immunity.

Input n signal

You can use this device parameter to specify whether or not the input level of the digital inputs should be saved.

- Retentive, i.e. latching mode (edge evaluation)
Regardless of the input signal present, the action can be deactivated again by another event.
- Non-retentive, i.e. jog mode (level evaluation)
This input action remains active for as long as the input is activated.

Input n level

You use this device parameter to specify the input logic:

- Normally closed contact
- Normally open contact

Note

If you specify "Input n action": "Emergency start", "Motor CW", "Motor CCW", and "Trip reset", you can only program "Input n level" as an NO contact.

Note

If "Input n level" is changed from an NC contact to an NO contact and the associated "Input n action" is parameterized as "Trip without restart", the "Input tripping" message bit is set and tripped accordingly in the event of an open input, as a result of the input delay.

Note

If an input voltage is applied (input active), a 1 is transferred to the controller regardless of the "Input n level"; please refer to the figure titled "Overview of input parameters".

Input n action

Different actions can be triggered when an input signal is present. You can parameterize the following actions depending on "Input n level", "Input n signal", and "Mode".

Note

If "Input n signal" = retentive and "Input n action" = motor CW/CCW, at least one input must be parameterized with input action "Tripping ... " or "Quick stop" at all times.

If this rule is not followed, the motor starter will reject the parameters and issue the relevant diagnostics message.

Input n action	Level	Signal	Mode	Description
No action	NO/NC	n-ret./ret.	All	-
Trip without restart	NO/NC	n-ret./-	All	<ul style="list-style-type: none"> Causes the motor and brake to trip. Must be acknowledged once the cause of tripping has been rectified (initial status).
Trip with restart (auto reset)	NO/NC	n-ret./-	All	<ul style="list-style-type: none"> Causes the motor and brake to trip. Acknowledged automatically once the cause of tripping has been rectified (initial status).
Trip end position CW	NO/NC	n-ret./-	All	<ul style="list-style-type: none"> The motor and the brake output are tripped regardless of the direction of rotation. The brake output can be switched on again once the "Brake" and "Motor CW/CCW" control commands have been canceled. Trip end position CW: The motor can only be switched on again with the opposite command ("Motor CCW"). Trip end position CCW: The motor can only be switched on again with the opposite command ("Motor CW").
Trip end position CCW (RSte/sRSSSte only)	NO/NC	n-ret./-	All	
Group warning	NO/NC	n-ret./ret.	All	<ul style="list-style-type: none"> The "Group warning" message is set. The motor starter and the brake output are not tripped. <p>ret.: <i>The input action responds to the active edge of the input signal. This makes deactivation with a pending active input signal possible. Action is deactivated with trip reset.</i></p>
Manual mode local	NO/NC	n-ret./-	All	<ul style="list-style-type: none"> Control is only possible via "Input n action": "Motor CW" and "Motor CCW" (see below) possible. Control is not possible over the fieldbus ("Automatic" mode). "Automatic" mode can only be reinstated if manual mode local is canceled and "Input n action": "Motor CW" or "Motor CCW" is not active.
Emergency start	NO/-	n-ret./-	All	<ul style="list-style-type: none"> Switches on the motor when an ON switching command is issued in spite of the fact that an internal trip command is present. Switches on the brake output too if an ON switching command is present for this. Self-protection of the motor starter remains active and prevents the device from being destroyed. Only allowed as an NO contact.

3.7 System monitoring

Input n action	Level	Signal	Mode	Description
Motor CW	NO/-	n-ret./ret.	Manual local	<ul style="list-style-type: none"> The motor starter must be in "manual local" mode for these actions. The device parameters of the braking operation are evaluated. "Motor CW": Switches the motor and the brake output on and off (clockwise) at the same time. "Motor CCW": Switches the motor and the brake output on and off (counter-clockwise) at the same time. Only allowed as an NO contact. <p>ret.: <i>The input action is triggered while the active level of the input signal is pending. Input trigger is canceled using the input action "Quick stop" or group fault.</i></p>
Motor CCW (RSte/sRSSte only)	NO/-	n-ret./ret.	Manual local	
Quick stop	NO/NC	n-ret./ret.	All	<ul style="list-style-type: none"> The motor and brake output are switched off without a group fault. "Quick stop" has priority over "Motor CW" and "Motor CCW". <p>ret.: <i>The input action responds to the active edge of the input signal. This makes deactivation with a pending active input signal possible. The input trigger is canceled by removing the control commands "Motor CW" and "Motor CCW"</i></p>
Trip reset	NO/-	n-ret./-	All	<ul style="list-style-type: none"> "Trip reset" is triggered once. Only possible as NO contact.
Cold run	NO/-	n-ret./-	All	<ul style="list-style-type: none"> Enables switch-on without main power supply. If the main power supply is present (current is flowing), however, an internal trip command is generated.
NO NC Ret. N-ret.	Normally open contact Normally closed contact Retentive Non-retentive Activation and deactivation of the input action follows the status of the input signal (= jog) ^			

Quick stop

- The motor and brake output are switched off without a group fault.
- "Quick stop" has priority over "Motor CW" and "Motor CCW".
- The input action responds to the active edge of the input signal, which means that deactivation is possible when the static input signal "Quick stop" is present.
- The input trigger is canceled by removing the "Motor CW" and "Motor CCW" control commands or using "Disable quick stop" (in the process image).

Example 1:

Digital input 1 signal = retentive/edge-triggered

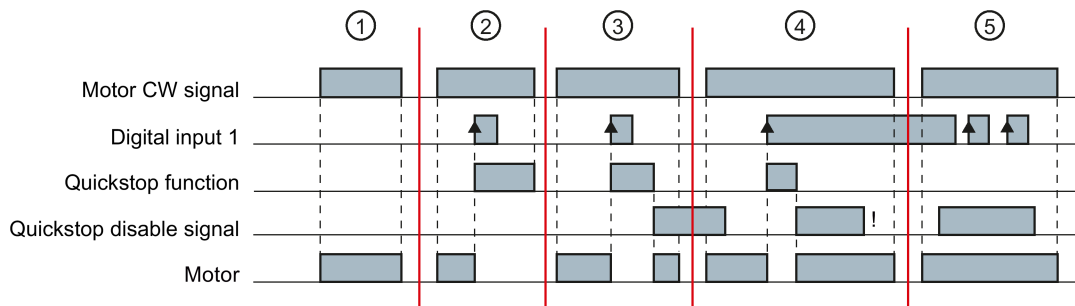

- ① Motor is switched on by "Motor CW".
- ② Motor is switched on by "Motor CW", then switched off by the rising edge at digital input 1 (parameterized to input action1 = Quickstop). By revoking the "Motor CW" command, the Quickstop function is reset.
- ③ Motor is switched on by "Motor CW", then switched off by the rising edge at digital input 1. By setting Quickstop disable, the Quickstop function is reset and the motor runs "CW" again until the "Motor CW" command is revoked.
- ④ Motor is switched on by "Motor CW", then switched off by the rising edge at digital input 1. By setting Quickstop disable, the Quickstop function is reset and the motor runs "CW" again. Although the static digital input signal 1 (DI2) is still present, the motor continues to run and is only reset by revoking the "Motor CW" command. Reason: The input action is edge-triggered.
- ⑤ Motor is switched on by "Motor CW" and continues to run uninterrupted since Quickstop disable continuously overwrites the edges of the signal of digital input 1 (DI2).

Figure 3-8 Quick stop (example 1)

Example 2:

Digital input 1 signal = non-retentive/level-triggered (default setting)

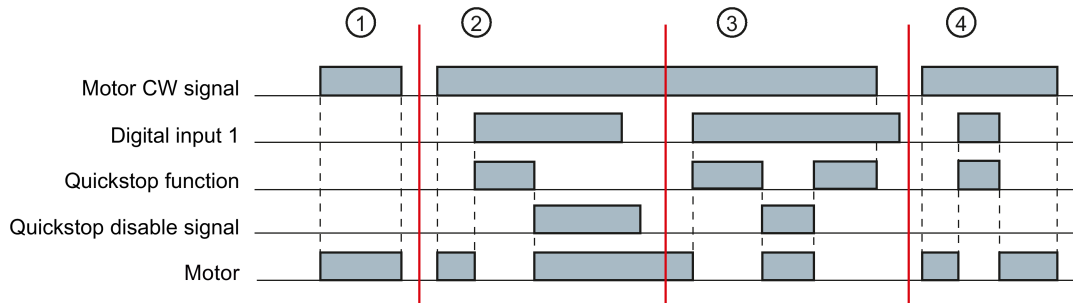

- ① The motor is switched on and off by "Motor CW".
- ② The motor is switched on by "Motor CW", then switched off by the level at digital input 1 (parameterized with input action 1 = Quickstop). The Quickstop function is reset by Quickstop disable. The motor is switched on again since "Motor CW" is still active.
- ③ The motor is switched off by the level at digital input 1. By setting "Quickstop disable", the Quickstop function is reset and since the level "Motor CW" is still active, the motor runs "CW" again until "Quickstop disable" is revoked.
- ④ Motor is switched on by "Motor CW", then switched off by the level at digital input 1. While the "Quickstop" function is active, the motor remains switched off and starts up again when "Quickstop" is revoked until "Motor CW" is switched off.

Figure 3-9 Quick stop (example 2)

Settings

Device parameter	Default setting	Setting range
Input signal extension (Motor Starter ES)	0 ms	0 to 200 ms Increment: 10 ms
Input signal delay (Motor Starter ES)	10 ms	10 to 80 ms Increment: 10 ms
Input 1 level	Normally open contact	<ul style="list-style-type: none"> • Normally closed contact • Normally open contact
Input 2 level		
Input 3 level		
Input 4 level		
Input 1 action	No action	<ul style="list-style-type: none"> • No action • Trip without restart • Trip with restart • Trip end position CW • Trip end position CCW (RSte/sRSSte only) • Group warning • Manual mode local • Emergency start • Motor CW • Motor CCW (RSte/sRSSte only) • Quick stop • Trip reset • Cold run
Input 2 action	No action	
Input 3 action	No action	
Input 4 action	No action	
Input 1 signal	Non-retentive	<ul style="list-style-type: none"> • Retentive • Non-retentive
Input 2 signal		
Input 3 signal	Non-retentive	<ul style="list-style-type: none"> • Retentive • Non-retentive
Input 4 signal		

Note

Individual parameters can only be set using Motor Starter ES.

Messages and actions

Message	Action
Input 1	Dependent on parameterization
Input 2	Dependent on parameterization
Input 3	Dependent on parameterization
Input 4	Dependent on parameterization
Input tripping	Trip
Input tripping - end position CW rotation	Tripping (must be acknowledged with Motor OFF)
Input tripping - end position CCW rotation	
Input control	The motor is controlled via the inputs
Input warning	The motor is controlled via the inputs
Sensor supply overload	Tripping (must be acknowledged with trip reset) The signal states of all inputs are undefined in the event of a "sensor overload".
Quick stop active	Trip

3.7.4 Outputs

Description

The motor starter can use the "outputs" device function to control various actuators (e.g. indicator lights or signaling auxiliary switches). In this case, control processes can be carried out from different control sources. Different functions and information can be parameterized for the output.

The digital output is overload/short-circuit proof and is supplied from U_{AUX}.

Note

The digital output must not be connected to a digital input because this can establish an impermissible connection between the U_{AS-i} and U_{AUX} voltages.

Output n level

With this device parameter, you determine whether the control signal of the output is inverted or not dependent on the set parameter.

Output n signal

With this device parameter, you determine how the signal is to be output:

- Continuous signal
- Flashing

Output n action

Different parameterizable actions can be triggered when an output signal is present.

Settings

Device parameter	Default setting	Setting range
Output 1 level	Non-inverted	<ul style="list-style-type: none"> • Non-inverted • Inverted
Output 1 signal	Continuous signal	<ul style="list-style-type: none"> • Continuous signal • Flashing
Output 1 action	Control source PIO DO2 (Slave 1)	<p>Control by means of external control source</p> <ul style="list-style-type: none"> • Control source PIO DO2 (Slave 1) (output) • Control source input 1 • Control source input 2 • Control source input 3 • Control source input 4 <p>Control via motor starter</p> <ul style="list-style-type: none"> • Run-up • Operation/shunting • Coasting down • On time motor (RUN) • Control command motor ON • Brake output • Device ON (PWR-AUX) <p>Control by means of messages from the motor starter</p> <ul style="list-style-type: none"> • Group prewarning • Group warning • Group fault • Bus error • Device error • Ready for motor ON

Messages and actions

Message	Action
Output 1 active	The output is controlled
Output overloaded	Tripping (acknowledgment via trip reset)
Output BO (brake output) active	The brake output is controlled

3.7.5 Connector monitoring

The motor starter monitors whether the infeed connector on the line side of the motor starter is plugged in. Connector monitoring is implemented by means of an input activated via a jumper between pins 11 and 12, which informs the motor starter that the connector is plugged in.

Note

When you use the "connector monitoring" function, you have to connect pin 11 to pin 12 in the connector.

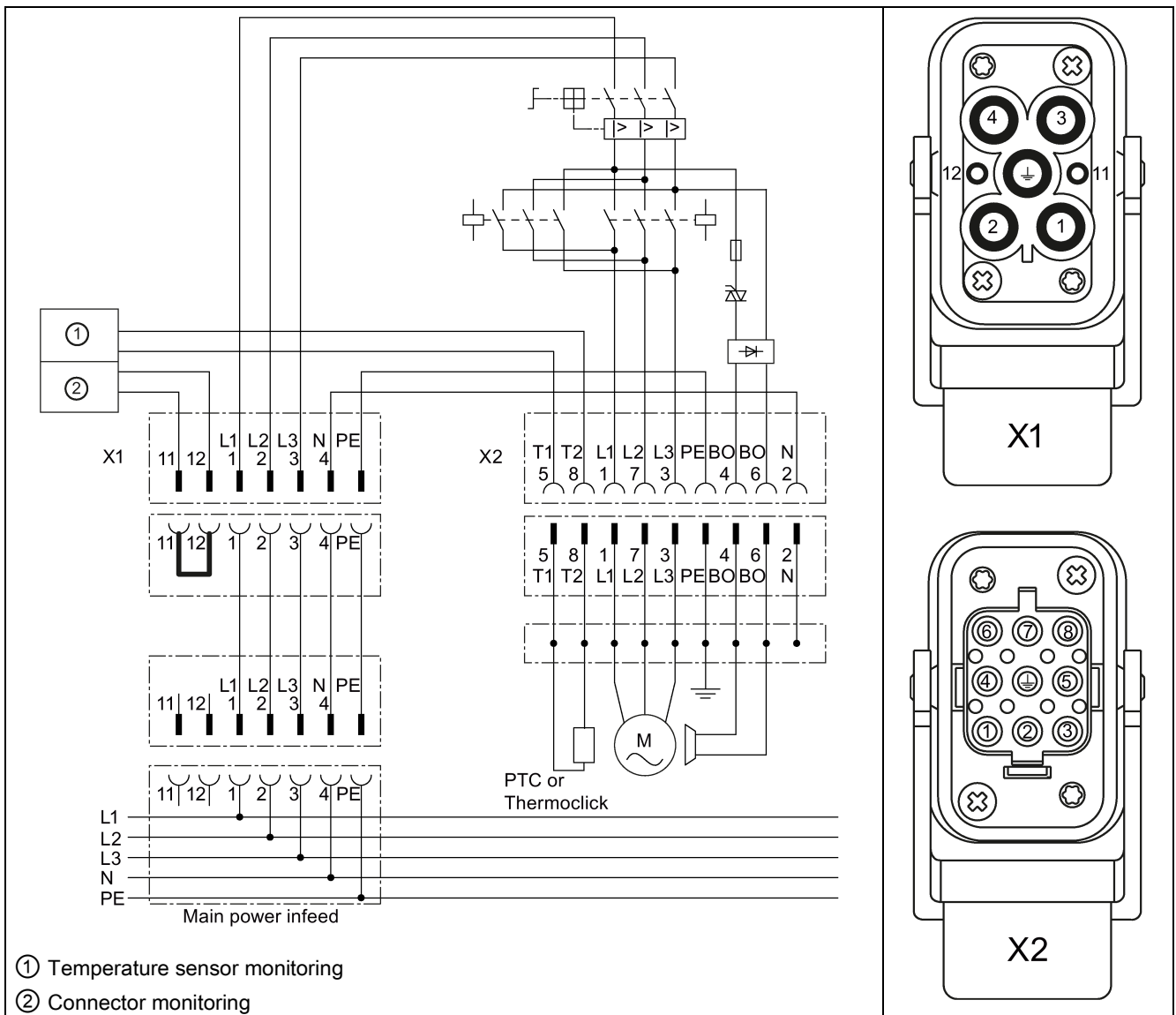

Connector monitoring

Line-side connector monitoring can be deactivated.

Response when connector removed

You use this device parameter to determine how the motor starter is to respond when the connector is removed:

- Group fault
- Group fault only after ON command
- Group warning

Settings

Device parameter	Default setting	Setting range
Connector monitoring	Deactivated	<ul style="list-style-type: none"> • Deactivated • Line side
Response when connector removed	Group fault	<ul style="list-style-type: none"> • Group fault • Group fault only after ON command • Group warning

Messages and actions

Message	Action
Connector monitoring deactivated	No monitoring on plugged-in connector
Connector disconnected on line side	Dependent on parameterization

3.7.5.1 Motor connector

The "connector monitoring" function is only valid for the infeed connector.

A connector monitoring function for the motor connector can be logically combined with the thermistor cable and/or thermistor evaluation function.

If a motor is operated without a thermistor, you can activate thermistor monitoring (thermoclick) and use it to monitor the connector by means of a wire jumper on the motor terminal board or in the motor connector.

Note

In this case, the "temperature sensor overload" message must be interpreted as a removed motor connector.

3.8 Short-circuit protection (circuit breaker/disconnecting means)

Description

The motor starter is equipped with an integrated circuit breaker for short-circuit protection to ensure that the system is safe and to protect personnel. Short-circuits between one phase and ground (= ground fault) as well as between two phases are monitored.

Properties of the circuit breaker

The circuit breaker / disconnecting means is designed for the following functions:

- Disconnecting the series-connected starter and consumer from the supply voltage
- Closing lockout by means of a padlock on the rotating element
- Short-circuit protection for the series-connected consumer with circuit breaker
- Reset in the event of a restart
- Restoration of factory settings, see Factory settings (Page 78)

Response to circuit breaker OFF:

You can use this parameter to determine how the motor starter is to respond to a short-circuit or to manual switch-off of the circuit breaker:

- Group fault
- Group fault only after ON command
- Group warning

See also

Factory settings (Page 78)

Settings

Device parameter	Default setting	Setting range
Response to circuit breaker OFF	Group fault	<ul style="list-style-type: none"> • Group fault • Group fault only after ON command • Group warning

Messages and actions

Message	Action
Circuit breaker tripped	Dependent on parameterization

3.9 Communication

Description

Communication is a higher-level device function comprising a number of sub-functions:

- Mode monitoring
- Fieldbus interface
- Commands
- Data plausibility check
- Messages output

3.9.1 Communication paths

3.9.1.1 Communication path - Process image

The cyclic process image PII/PIO with 6I/4O is made up of:

- Slave 1: 2I/1O
- Slave 2: 4I/3O

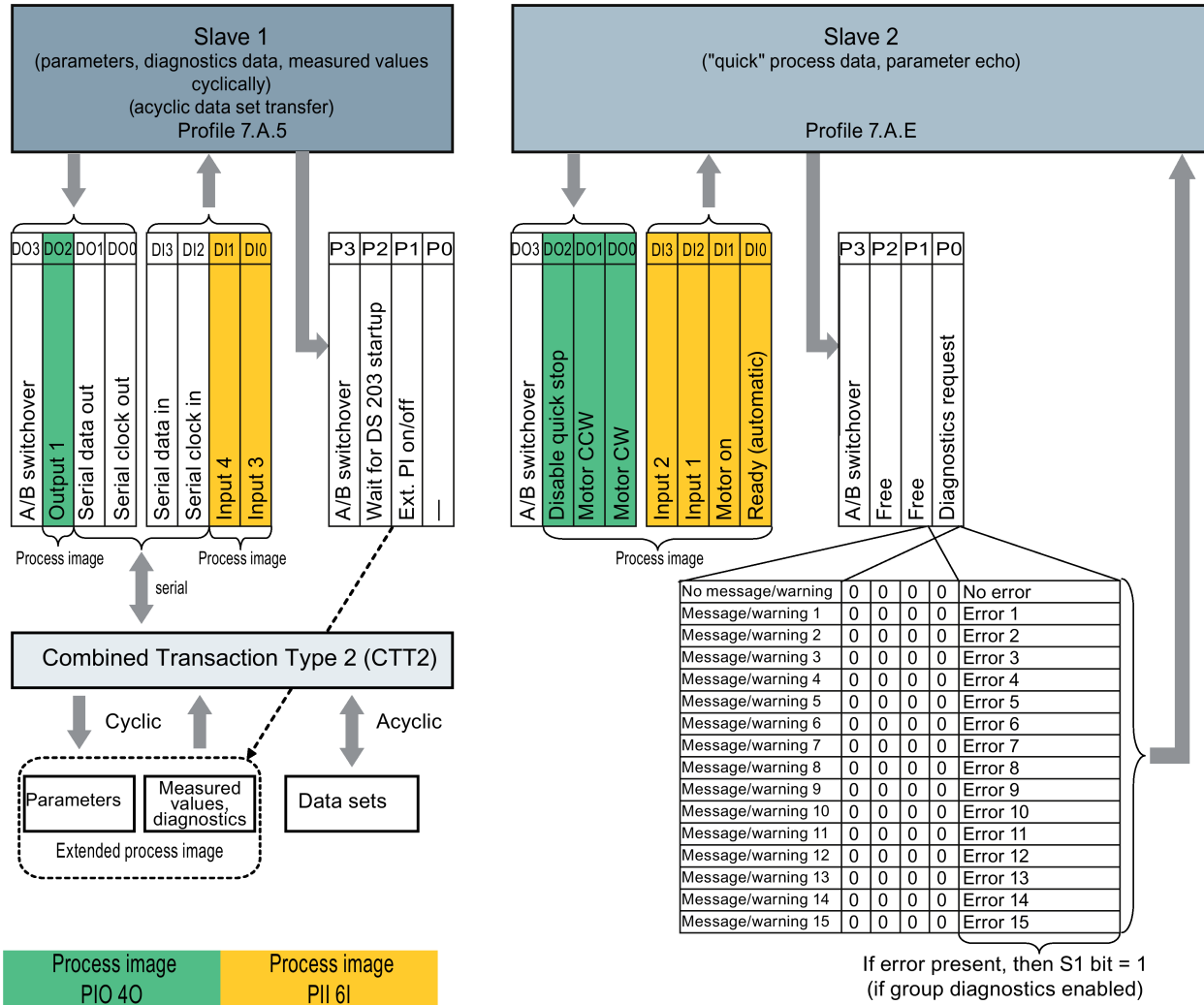

Note

The cyclic process image occupies 2 addresses in the PLC: Slave 1: 2I/1O and Slave 2: 4I/3O

3.9.1.2 Communication path - Diagnostics

The AS-i master enters the value of the I/O fault bit (S1) on the slave status tab in the list of I/O faults (LPF) that have been signaled. The PLC can read out this list using the "GET_LPF" command and then return a specific diagnostic value from the slave (see Diagnostics via parameter channel) (Page 137)).

Slave diagnostics echo (parameter echo)

Bit P0 defines whether a fault diagnosis (P0 = 1) or warning/message diagnosis (P0 = 0) is returned to the master as a slave response.

The "Write_Parameter" command (see the manual for the AS-i master) is used to send the parameter value P0 (= 0 or 1) to the AS-i master and, therefore, to Slave 2. P3 is set by the system, P1 and P2 can have any values.

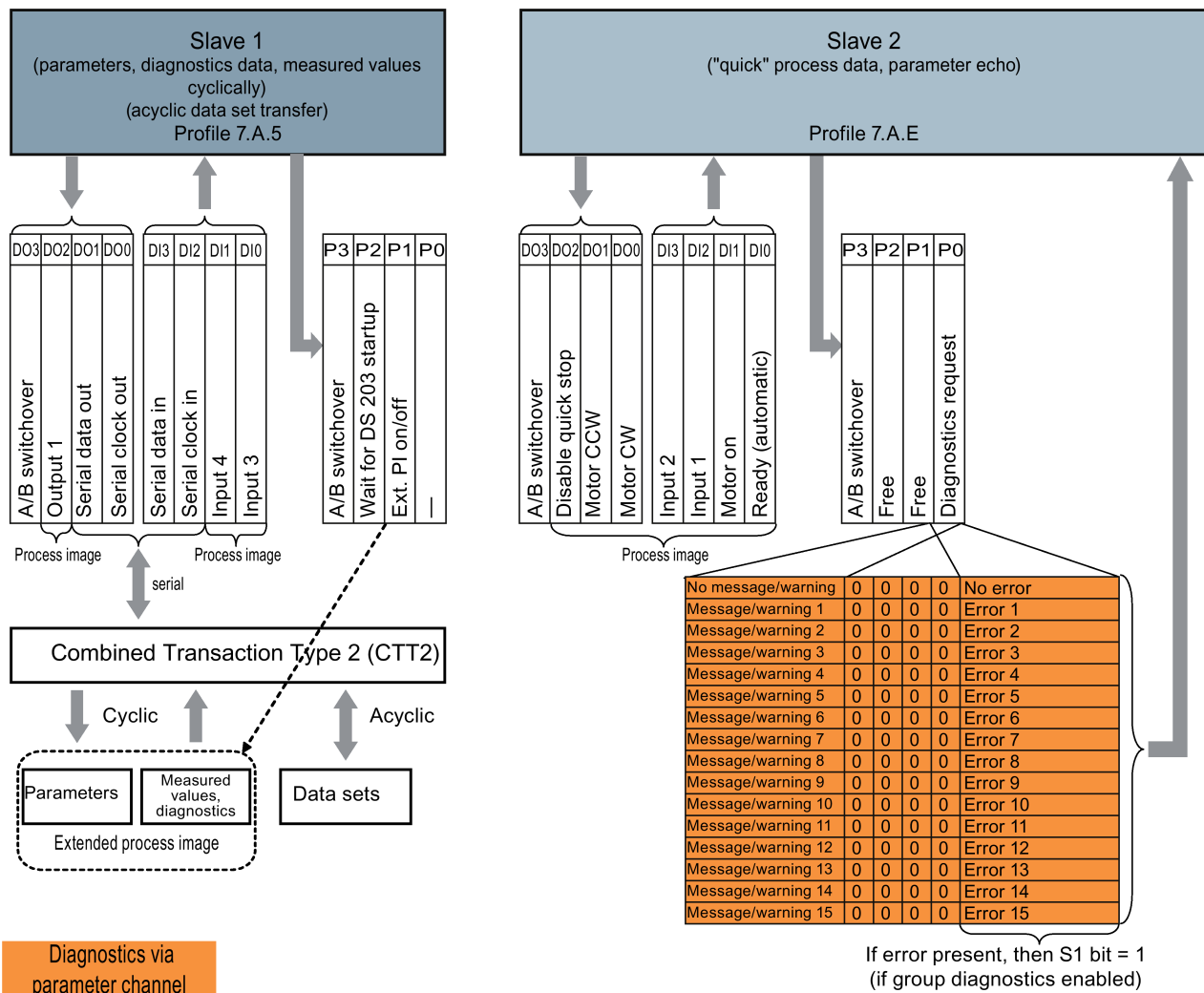

3.9.1.3 Communication path - Extended process image

CTT2 transfer is used for transferring serial data sets between the AS-i master and slave. Dependent on configuration, the M200D AS-i Standard always differentiates between two possible mechanisms:

1. Transfer of the "extended process image" of 4 bytes.
In the description of the AS-i system, this mechanism is used to transfer analog data. M200D uses these 4 bytes for parameter assignment, diagnostics, or measured value data, see the table Extended process image (Page 123).
2. Transfer of pre-defined data sets
see the description of data sets (Appendix A1 (Page 159)).

Reading out acyclic data sets:

- Device diagnostics reduced
- Measured values reduced
- Statistical data
- Device parameters

Writing acyclic data sets:

- Device parameters reduced
- Command data set

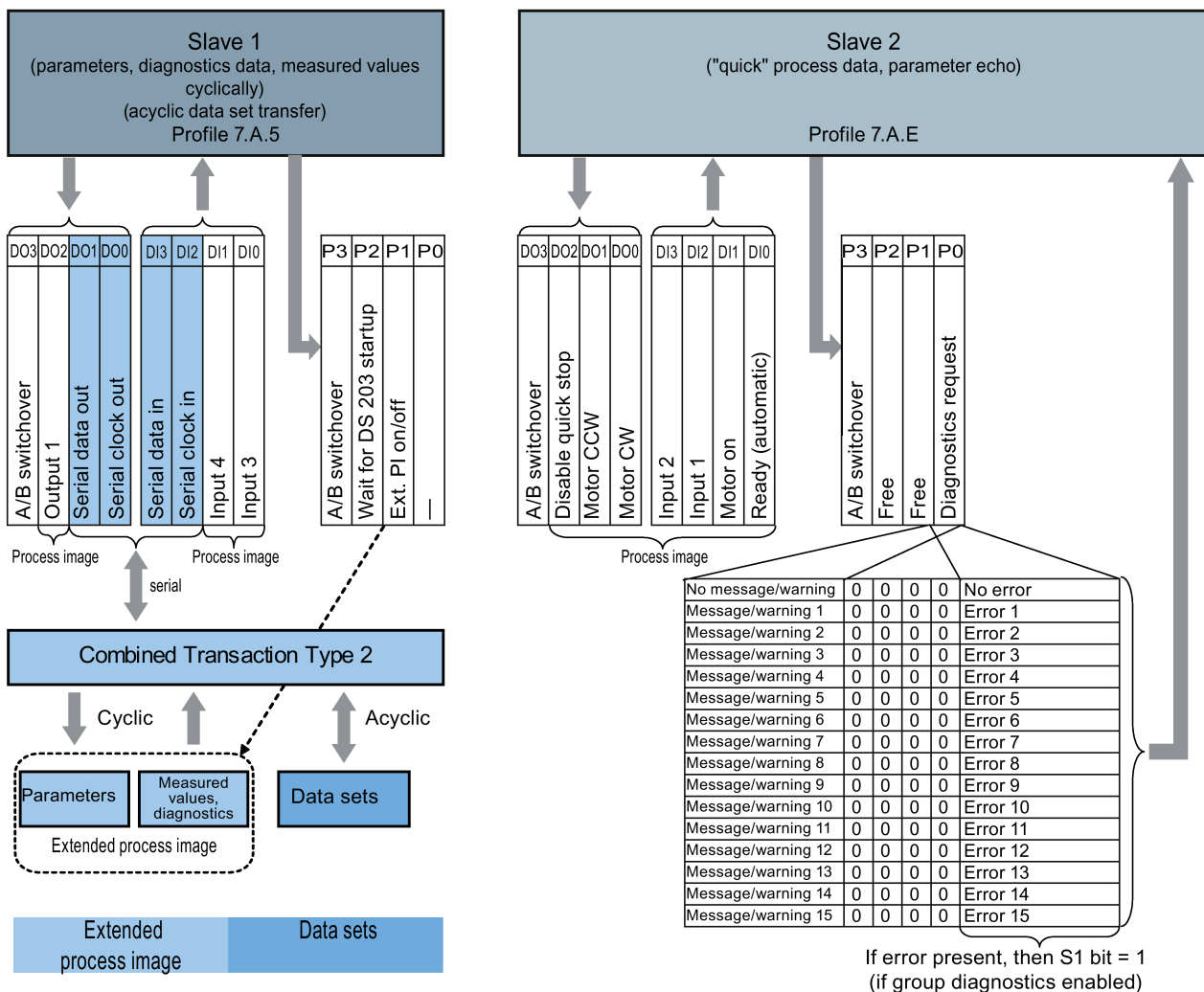

3.9.1.4 Communication path - Parameter bits

The parameter bits (P bits) are used to control both startup characteristics and operation of the slave.

The P bits are activated by default in HW Config. In the user program, you can choose between continual (cyclic) transfer and transfer on request.

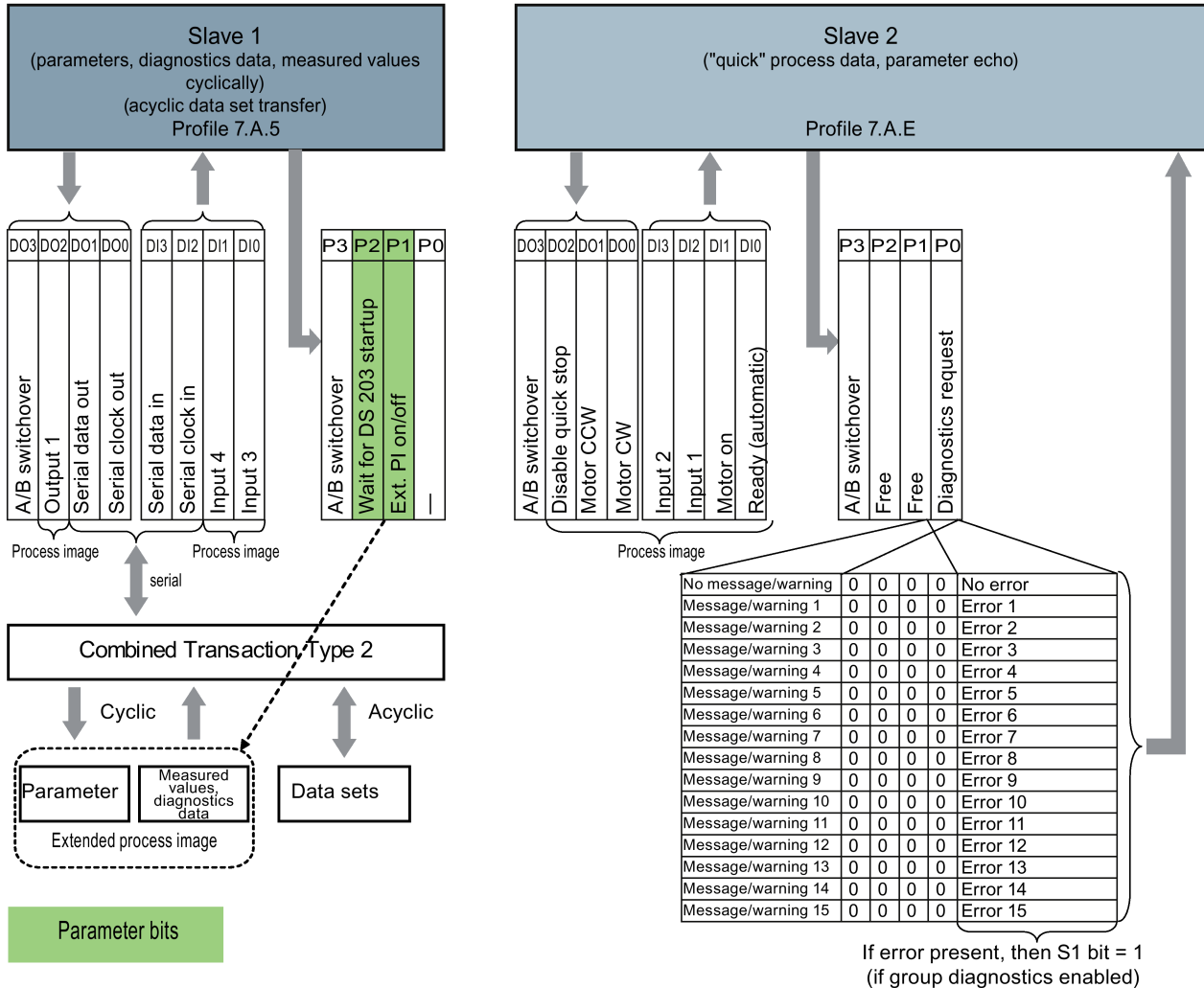

3.9.2 Mode monitoring

Data channels

M200D motor starters have 3 different data channels:

- Local optical device interface (for hand-held device/Motor Starter ES)
- Control with local control station in "manual local" mode
 - Using integrated manual local control (key-operated switch + keypad, order variant)
 - Input actions for digital inputs
- Via the fieldbus interface AS-Interface:
 - Cyclic data via AS-i
 - Extended cyclic process image
 - Acyclic data transfer

The data channel used for control purposes depends on the mode.

Modes

The following modes are available (in ascending order of priority):

- Automatic (lowest priority)
The motor starter can only be controlled with the PLC via the fieldbus.
- Manual mode local
The motor starter can be controlled with:
 - Integrated manual local control (e.g. keypad)
 - Local control station at digital inputs
(Motor CW, Motor CCW, e.g. with external switches)
Requirement: Manual mode local is set
 - Local device interface (e.g. hand-held device) (highest priority)

Note

A higher-priority mode can remove control priority from a lower-priority mode at any time by means of a command or the "Manual mode" input action, but a lower-priority mode cannot do this to a higher-priority one.

A lower-priority mode can only remove control priority if, while the motor is switched off, the higher-priority mode returns control priority by means of a key-operated switch, the "Automatic mode" command, or switching off the "Manual mode local" input action.

The following message bits in diagnostics data set DS 200 clearly indicate which control source currently has control priority:

- Automatic mode
- Manual mode local
 - Integrated manual local control controls
 - Input controls
- Connection abort in manual mode

Automatic	Manual				Control priority
	Manual mode bus	Manual mode local	Input control	Connection abort in manual mode	
Automatic mode	Manual mode bus	Manual mode local	Input control	Connection abort in manual mode	
0	0	1	0	0	Integrated manual local control or local device interface
0	0	1	0	1	None
0	0	1	1	0	Digital input
1	0	0	0	0	PLC (controller)

Connection monitoring

If the motor starter is controlled via the device interface (Motor Starter ES or hand-held device), this connection is monitored. If this connection is interrupted, the motor starter trips with the message "Connection abort in manual mode".

To exit this state, re-establish the connection and control again using the device interface.

Setting manual mode local for a local control station at the digital inputs

You can set manual mode local as follows:

- Parameterize the input n action as "Motor CW" or "Motor CCW" and the input n action of another input as "Manual mode local".
- As long as the second input is active, the motor starter remains in "manual local" mode and the motor can be controlled via the "Motor CW"/"Motor CCW" digital input.

3.9.3 Commands

Commands and their meaning

Using the commands, you can instruct the motor starter to perform specific actions. You can use the Motor Starter ES configuration software or command data set DS 93 (Page 172) to send the following commands to the motor starter:

Command	Meaning
Trip reset	<ul style="list-style-type: none"> • Resets and acknowledges error messages • Deletes message bits, if no error message is present • No effect
Emergency start ON	Activates the emergency start device function
Emergency start OFF	Deactivates the emergency start device function
Factory settings	All parameters (except for the communication parameters) assume the factory settings again. Only possible in manual mode.
Delete maximum pointer	Resets the "preventive diagnostics" statistical data
Restart	Motor starter executes restart (same effect as Power OFF/ON). Only possible in manual mode!
Parameters disabled CPU/master OFF	Motor starter accepts the parameters from the master (PLC)
Parameters disabled CPU/master ON	Motor starter ignores the parameters from the master (PLC)
Delete Logbook - Triggering operations	Delete logbook with recorded fault causes
Delete Logbook - Events	Delete logbook with recorded warnings and specific actions
Cold run ON	Enables activation of the switching contacts without main power
Cold run OFF	Switches the "cold run" function off

3.9.4 Data plausibility check

Description

The motor starter checks all incoming parameters to ensure that they are valid and plausible.

If parameters are incorrect:

- During a startup procedure (after Power ON), the messages "Group fault" and "Invalid parameter value" are set.
The motor and the brake output remain switched off.
- During operation, the messages "Invalid parameter value" or "Parameter assignment not possible in ON state" are set. "Group fault" is not set.
The motor and the brake output are not switched off.

Note

The parameter values that are currently valid are retained.

3.9.5 Messages output

Message	Meaning
General messages	
Ready (automatic)	<ul style="list-style-type: none"> • Device can be controlled via BUS • Automatic mode • No fault
Group fault	At least one fault is set.
Group warning	At least one warning is present.
Process image error	The process image of the outputs contains an illegal bit combination, e.g. motor CW and motor CCW set simultaneously.
Fieldbus interface	
Bus error	AS-i interface threshold monitoring expired.
CPU/Master STOP	PLC program is no longer processed.
Acknowledgment	
Trip reset executed	Trip reset accepted; that is, error/fault has been acknowledged.
Trip reset not possible	Fault could not be acknowledged since the cause of the tripping is still pending.
Mode monitoring	
Automatic mode	Automatic (PLC controls)
Manual mode local PC	Manual mode via local device interface Hand-held device, PC
Manual mode local input controls	Control signals at the inputs
Connection abort in manual mode	During manual mode, the relevant communication connection was interrupted for more than 5 seconds.
Parameter assignment	
Parameter assignment active	Yes/no
Invalid parameter value ¹⁾	Parameter not correct
Parameters cannot be changed in ON state ¹⁾	Attempt to change parameters while motor is running not permissible.
Parameters disabled CPU/master active	Motor starter ignores parameters from the PLC but informs the PLC that the parameters are in order.
No external startup parameters received	No new parameters have been received from the PLC after Power ON or restart of the motor starter.
¹⁾ Message bits that can be deleted with trip reset	

3.10 Logbook

Description

The logbook contains a chronological list of triggering operations, device errors, and events, which are assigned a time stamp and can be used to create a log. The log is stored internally so that the causes can be evaluated at a later stage.

Note

You require Motor Starter ES for this function.

Logbooks

There are 3 different logbooks that can be read out using Motor Starter ES:

- Logbook - Triggering operations
- Logbook - Events
- Logbook - Device errors

The current value for "Operating hours - Device" is entered as the time stamp.

The last 21 entries are stored in the logbooks.

The logbook has been designed as a circular buffer. After 21 entries, the oldest entry is overwritten.

Logbook - Triggering operations

The "Logbook - Triggering operations" contains all the group faults. The fault texts of the actual fault causes are entered, e.g. "Switching element overload".

Please note that the "Logbook - Triggering operations" is deleted with the command "Delete logbook - Triggering operations".

Logbook - Events

The "Logbook - Events" contains all the warnings as well as certain actions.

Please observe the following:

- "Incoming" and "outgoing" events are entered:
"Incoming" means: The event is occurring.
"Outgoing" means: The event is acknowledged.
The entries are differentiated in the data set by means of their sign:
(+: Incoming, -: Outgoing).
- The "Logbook - Events" is deleted with the command "Delete logbook - Events".

Logbook - Device errors

The "Logbook - Device errors" records all the device errors that occur.

Please note that the "Logbook - Device errors" cannot be deleted.

3.11 Emergency start

Description

An emergency start enables a restart to be carried out in spite of an internal trip command.

An emergency start can be carried out if

- An ON switching command is present for the motor. The motor is switched on despite the fact that the cause of a trip is still present. When a limit trip occurs, the motor starts in the opposite direction.
- An ON switching command is present for the brake output. The brake output is switched on (parameter "Brake release delay on starting" taken into account).

An emergency start cannot be carried out if

- An OFF switching command is present.
- A device error is pending.
Message bit: "Self-test error", "Switching element defective"
- The self-protection function of the motor starter has responded.
Message bit: "Switching element overload"
- Switched/unswitched supply voltage PWR/AUX-PWR is not present.
Message bit: "No switching element supply voltage"
"Electronics supply voltage too low"
- The blocking protection has responded.
Message bit: "Tripping due to motor blocking"
- A process image error is present.
Message bit: "Process image error"

Control options for emergency start

- Parameter "Input n action" → "Emergency start" parameterized
- Commands "Emergency start ON", "Emergency start OFF"

Messages and actions

Message	Description
Emergency start active	Present while emergency start is active, even if the motor and brake output are switched off.

3.12 Trip reset

Trip reset acknowledges all the errors/faults that are currently present in the starter and that can be acknowledged. An error/fault can be acknowledged if its cause has been rectified or if it is no longer present.

The trip reset can be triggered by:

- Remote reset via the bus interface (DO 0 CW ON and DO 1 CCW ON simultaneously, both edges in the same AS-i cycle)
- Remote reset via input action (if parameterized)
- Local reset via the device interface (hand-held device or ES tool)
- Local reset via the key-operated switch (0 position; order variant)
- Power ON reset (24 V DC PWR supply switched off and on again) only if protection against voltage failure is deactivated (parameterizable).
- Reset via disconnecting means
Please set the rotary switch from 0 to 1 for this purpose.

You can find more detailed information in Acknowledging faults (Page 142).

3.13 Self-test

Description

Two types of self-test can be carried out:

- Self-test at switch-on
This is automatically selected when the device is switched on or initialized.
- Self-test during operation:
The motor starter cyclically monitors specific device components and signals any errors (device errors).

Test steps

The self-test involves 3 test steps. These steps are carried out in relation to the signal duration of the test command:

Test step	Signal duration	Test scope	Explanations
1	< 2 s	LED test	All LEDs are switched on for 2 seconds. <ul style="list-style-type: none"> • User check, no message bit
2	2 to 5 s	Hardware test	The hardware of the motor starter is tested; current measurement indicated by the "DEVICE" LED: <ul style="list-style-type: none"> • Current flowing: Flashing red • Current not flowing: Flickering red • User check, no message bit
3 ¹⁾	> 5 s	Trip	Switching elements are switched off.

¹⁾ This test step is only executed in manual mode.

Self-test error

If an error occurs, the "DEVICE" LED lights up red. The error can only be acknowledged by switching the device off and then on again. If the error is still present, the self-test will return an error again when the device is switched on. In this case, the motor starter will need to be replaced.

Messages and actions

Messages	Actions
Self-test error	Trip
Switching element defective	Trip (if possible)

Note

When diagnostics is carried out via the parameter channel (parameter echo), both messages are combined to form the "Device error" message.

Note

Specific device components are monitored continuously (internally) by the motor starter and the results signaled with the self-test messages. The message "Self-test error" may also appear in the event of an internal monitoring error occurring, even if the self-test has not been activated.

3.14 Factory settings

Description

The factory settings restore the settings of the motor starter as supplied, that is, the motor model is deleted, faults are reset (if possible), and the operating hours counter is deleted, etc.

This provides the option of resetting the motor starter in the event of incorrect parameterization.

Note

Current maximum pointer and statistical data are not deleted.

Restoring factory settings

You can restore the factory settings as follows:

- With the "Factory setting" command (using data set 93 or Motor Starter ES).
This is only possible if "Manual" mode is set and the switching elements are deactivated.
- With the disconnecting means
Turn the knob of the disconnecting means within the specified time window of 2 to 4 seconds to the positions ON and OFF as shown in the time diagram below, and monitor the LEDs on the motor starter as you do so.

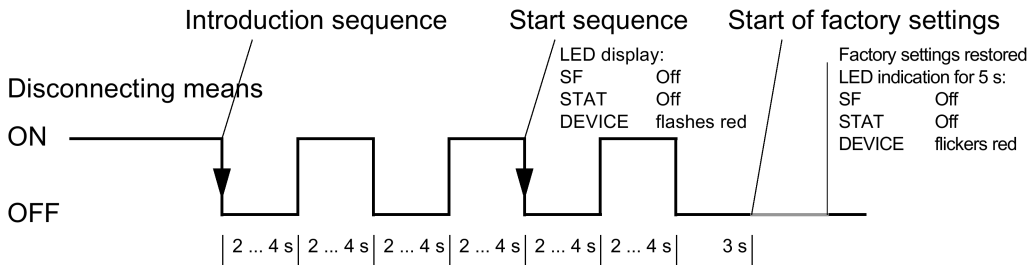

Figure 3-10 Factory settings

The introduction sequence prevents accidental resetting to the factory settings. The factory setting operation is introduced with the beginning of the start sequence. The LEDs behave as follows here:

- SF off
- STAT off
- DEVICE flashes red

When the factory settings are restored, the LEDs behave as follows for 5 seconds:

- SF off
- STAT off
- DEVICE flickers red

Messages and actions

Messages	Meaning
Factory settings restored ¹⁾	All parameters now again have the values set at the factory.
¹⁾ Message bits that can be deleted with trip reset	

Note

Parameters that are transferred via the expanded process image (if activated) overwrite the factory settings again.

3.15 Main power monitoring

Description

With electronically switching motor starters with soft starting, the main power is monitored for the following:

- Supply voltage
- Phase failure
- Rotational direction of line frequency

Messages and actions

Message	Action
No supply voltage	ON command generates faults
Phase failure L1	ON command generates faults
Phase failure L2	ON command generates faults
Phase failure L3	ON command generates faults
Rotational direction of line frequency right	—
Rotational direction of line frequency left	—

3.16 Electronic/mechanical switching

Electronic switching

The motor starter controls the motor (two phases) with thyristors. Phase L1 is not switched but is instead looped through from the 400 V power connection to the motor connection via the integrated disconnecting means.

! DANGER

Hazardous Voltage
Can Cause Death or Serious Injury.

If the line voltage is present at the 400 V power connection of the motor starter, hazardous voltage may still be present at the motor starter output even if a start command has not been issued.

When carrying out any work on the branch, make sure that you disconnect it via the disconnecting means.

Mechanical switching

The motor starter controls the motor in 3 phases with contactors.
 On device versions with a rated operating current of 0.15 - 2A (3RK13...6KS41) RC elements for damping interference pulses are integrated on the outgoing side of the motor.

Switching element defective

If a switching element is defective (contactor welded / thyristor failure), the motor starter cannot shut down the motor.

Note

If necessary, evaluate the message "Switching element defective" and shut down the branch on the basis of this by means of an upstream switching element.

Messages and actions

Message	Action
Switching element defective	Trip (if possible)
Switching element short-circuited (e.g. contactor contact welded, power semiconductor fused)	Trip (if possible)
Switching element overload (e.g. power semiconductor too hot)	Trip
Motor CW	—
Motor CCW (on reversing starters only)	—
Electronics supply voltage too low	—
No switching element supply voltage	Trip (acknowledgment of voltage recovery)
Ready for motor ON	Dependent on parameterization

3.17 Cold run

Description

This function enables activation of the motor without main power supply. The motor starter responds here as if the main power supply were connected to the system. Thus, in the commissioning phase, for example, the relevant control commands are accepted from the controller and the relevant messages are sent.

Note

If the main power supply is nevertheless present (current flowing), an internal trip command is generated.

The "cold run" function can be activated as follows:

- Input action "cold run"
- Commands: Cold run ON /OFF

If the "cold run" function is active, the motor switches off if

- A current flow is detected
- Main power supply is detected.

Messages and actions

Message	Action
Cold start active	—
Cold start tripping	Tripping (acknowledgment via trip reset)

3.18 Local device interface

Description

The local optical device interface can be used to connect the motor starter to a PC or handheld device (order no.: 3RK1922-3BA00; RS 232 interface cable: 3RK1922-2BP00). This control source has the highest priority.

To stop the fiber-optic cable for the device interface from getting dirty, it is located under the removable unit labeling plate.

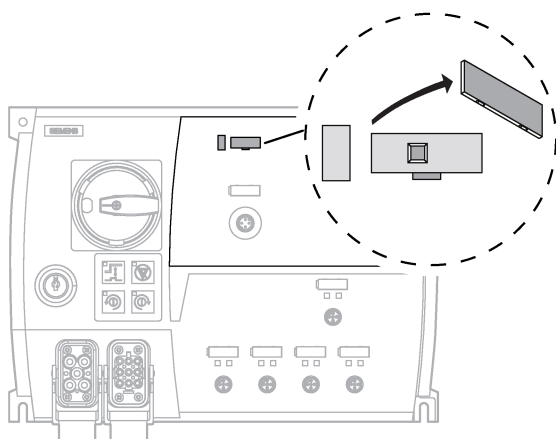

Figure 3-11 Optical device interface

Note

To ensure that data can be transferred without any problems, make sure that the device interface is clean at all times.

3.19 Integrated manual local control

Integrated manual local control (ordering option) for the M200D motor starter involves a key-operated switch and a keypad with four pushbuttons.

Key-operated switch

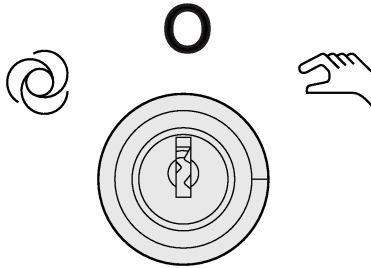





Figure 3-12 Key-operated switch

The key-operated switch can be set to three different positions.

Position	Meaning	Function
	Automatic mode	The pushbuttons on the keypad have no function. The LEDs on the "quick stop disable", "RIGHT", and "LEFT" pushbuttons, however, are active. They are used for indicating the status (= status of control via the PIO).
	Manual mode	Control priority is assumed by a lower-priority control source (automatic mode) and transferred to the keypad. When you switch back to "REMOTE", control priority is always initially passed to the CPU/master.
	OFF / Reset	The motor starter does not execute any control commands in this position (regardless of the control source). When "exiting" this switch position (after both automatic and manual mode), any error/fault that is still present is acknowledged. This reset is carried out regardless of the current operating mode.

Note

The key can be inserted/removed in any position.

Keypad

The keypad has four pushbuttons arranged in a square.

Note

They are only active when the key-operated switch is set to manual mode.

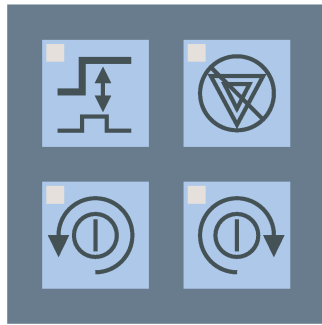
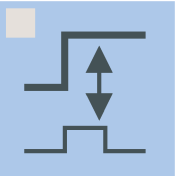

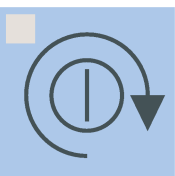
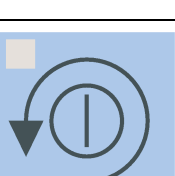

Figure 3-13 Keypad

Pushbutton	Meaning	Function
	Continuous operation / jog mode	The mode switches every time you press this pushbutton (continuous / jog). "Continuous" mode is indicated via the corresponding LED (yellow, lit up) (in manual mode only). When manual mode is deactivated, the system is reset to jog mode.
	Quick stop disable	The "quick stop" input actions are deactivated for all inputs. This pushbutton is active in jog mode and continuous operation. In continuous operation, the "quick stop disable" function can be activated by pressing the pushbutton once and deactivated by pressing it again. The yellow LED lights up regardless of the operating mode (as long as the function is active).
	Clockwise rotation	The main circuit for CW operation is activated. In continuous operation, the main circuit can be activated by pressing the pushbutton once and deactivated by pressing it again. With reversing starters, an ongoing action can also be interrupted in continuous operation by pressing the "CCW rotation" pushbutton. The green LED lights up regardless of the operating mode (as long as the selected function is active).
	Counterclockwise rotation	This pushbutton is only enabled for reversing starters. The main circuit for CCW operation is activated. In continuous operation, the main circuit can be activated by pressing the pushbutton once and deactivated by pressing it again. In continuous operation, an ongoing action can also be interrupted by pressing the "CW rotation" pushbutton. The green LED lights up regardless of the operating mode (as long as the selected function is active).

Note

If the "CW rotation" and "CCW rotation" pushbuttons are pressed simultaneously, this is classed as an operation fault. A function cannot be restarted. A function that is being executed is interrupted (the starter shuts down).

A function cannot be restarted until both pushbuttons have been released.

Note

When the "CCW rotation" or "CW rotation" pushbuttons are actuated, a connected brake is also always actuated.

Mounting/Connecting

4.1 Mounting

4.1.1 Installation rules

! DANGER

Hazardous voltage

Can Cause Death, Serious Injury, or Property Damage

Before starting work, disconnect the system and devices from the power supply.

Simple installation

The distributed M200D AS-i motor starter is designed as a complete device that is easy to install. Carry out the following steps:

1. If you are using the optional protection guards, install these first.
2. Install the motor starter on a flat surface.

Installation position

The M200D AS-i motor starter is designed for the following installation positions on a flat surface:

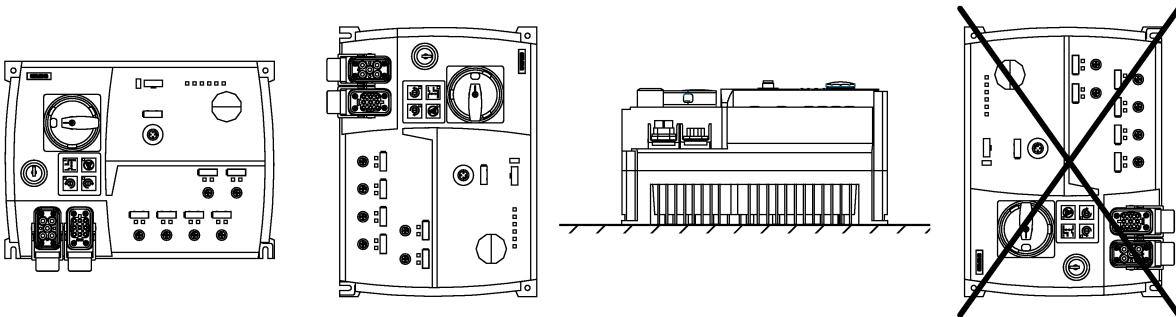

Figure 4-1 Installation positions: horizontal, vertical, flat; must not be positioned as shown on the right

4.1.2 Derating

What is derating?

Derating allows devices to be used even in harsh operating conditions by selectively restricting the output capacity.

Derating factors

When M200D AS-i motor starters are operated under harsh conditions, the following factors must be taken into account:

- Ambient temperature T_a :
 - The ambient temperature T_a is the temperature of the air surrounding the motor starter enclosure.
The lower the maximum ambient temperature T_a , the higher the current load on the motor starter can be.
 - The installation position affects how quickly the motor starter cools.
- Absolute current load:
 - The lower the current flowing through the motor starter, the lower the power loss (= heat) inside the device. If a small amount of self-heating occurs, the ambient temperature T_a can be higher.
 - In the case of soft starters in which the soft start function has been deactivated, the maximum permissible rated operating current I_e is restricted to 9 A (\equiv electronic direct starter; sDSte).
- Installation altitude
If the installation altitude exceeds 1,000 m, a reduction of the rated operational current is required for thermal reasons. For more details, refer to the technical specifications: "Installation altitude". (Page 143)

Derating diagrams

You can use the following diagrams to determine the derating factors for horizontal, vertical, or flat mounting.

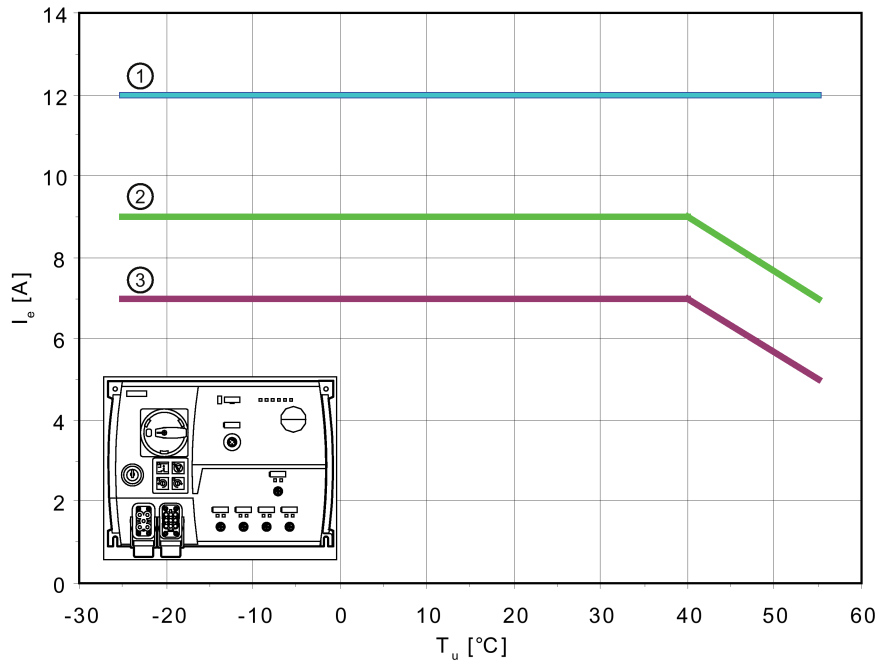

- ① DSte, RSte,
sDSSSte, sRSSSte with bypass in "soft start" startup mode (from 7 A)
- ② sDSSSte, sRSSSte with bypass in "direct" startup mode (from 7 A)
- ③ sDSSSte, sRSSSte without bypass in startup mode "Direct" and "Soft start"

DSte, RSte = electromechanical starter

sDSSSte, sRSSSte = electronic starter

Figure 4-2 Derating for horizontal mounting

4.1 Mounting

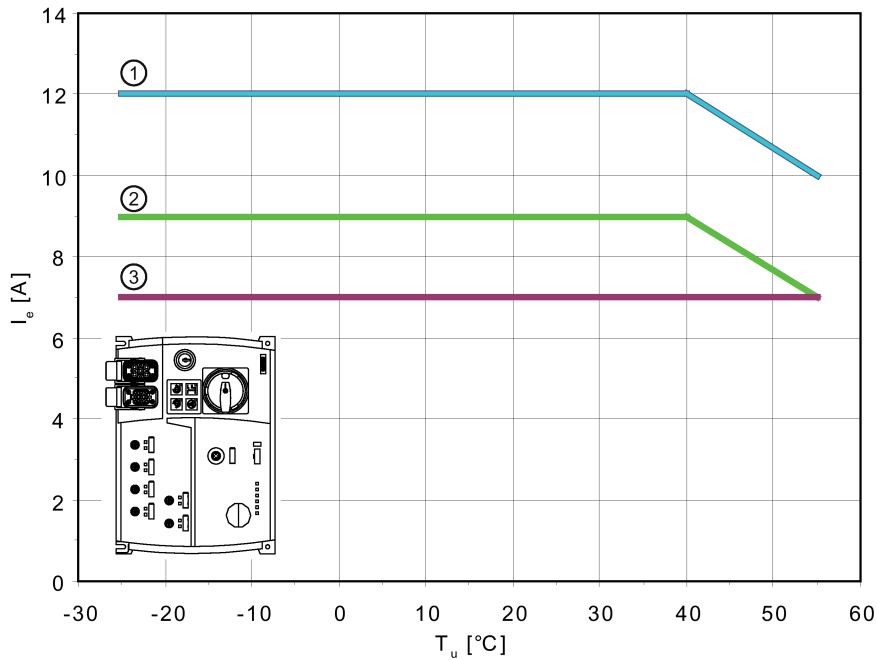

- ① DSt_e, RSt_e, sDSSSt_e, sRSSSt_e with bypass in "soft start" startup mode (from 7 A)
- ② sDSSSt_e, sRSSSt_e with bypass in "direct" startup mode (from 7 A)
- ③ sDSSSt_e, sRSSSt_e without bypass in startup mode "Direct" and "Soft start"

Figure 4-3 Derating for vertical mounting

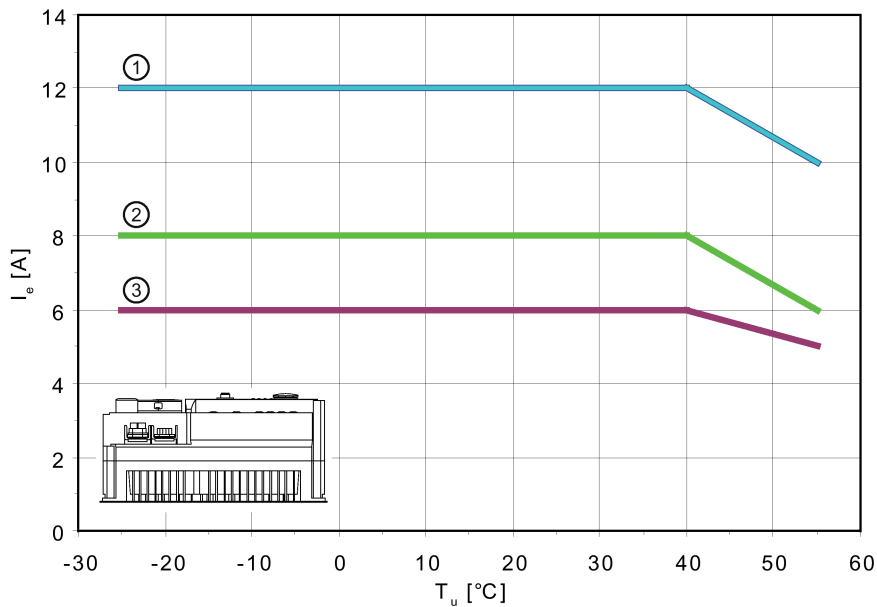

- ① DSt_e, RSt_e, sDSSSt_e, sRSSSt_e with bypass in "soft start" startup mode (from 7 A)
- ② sDSSSt_e, sRSSSt_e with bypass in "direct" startup mode (from 7 A)
- ③ sDSSSt_e, sRSSSt_e without bypass in startup mode "Direct" and "Soft start"

Figure 4-4 Derating for flat mounting

Motors with a high efficiency and high motor starting currents

High starting currents may have to be taken into consideration when using motor starters on high-efficiency motors. Motor starters are designed for motors with a maximum 8-fold starting current in accordance with IEC 60947-4-2.

If motors are operated that have a higher starting current, refer to the following table for the maximum adjustable motor current:

Motor starter version I_e [A] at 40 °C max. motor starting current	3RK1325-6KS*	3RK1325-6LS41*	3RK1325-6LS71*
≤ 8 -fold I_e	2 A	12 A	12 A
9-fold I_e	1.7 A	10 A	8 A
10-fold I_e	1.5 A	9 A	7 A

4.1.3 Installing the protection guards

Protection guard (accessory)

NOTICE

The protection guards are designed for a maximum load of 10 kg.

To prevent mechanical damage to the motor starter cables and connections, you can install protection guards on the side and top (order no.: 3RK1911-3BA00).

To secure the protection guards, the angled ends can be used as clamping bolts, which are secured in the device base by means of eccentric elements.

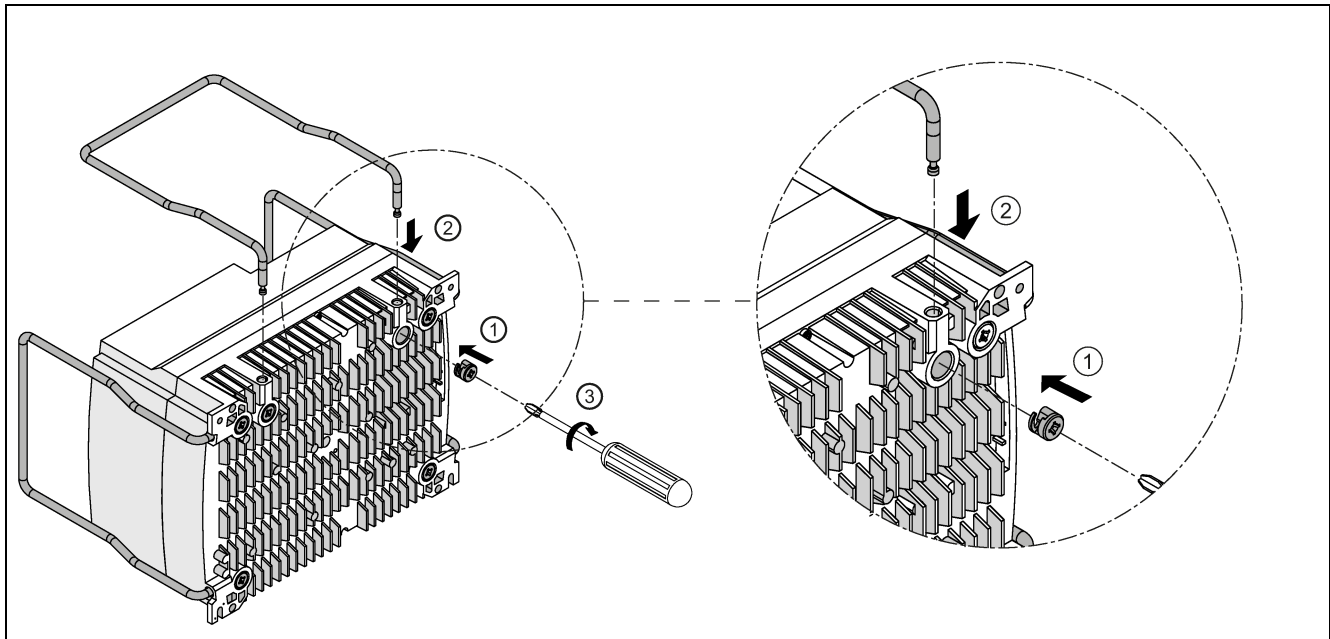

①	Insert the eccentric elements in the locating holes on the bottom of the motor starter. Make sure that the holes are aligned for the protection guards.
②	Push the ends of the protection guards into the holder until they engage.
③	Turn the eccentric elements clockwise until the protection guard is secure.

4.1.4 Installing the motor starter

Carry out the following steps to install the motor starter:

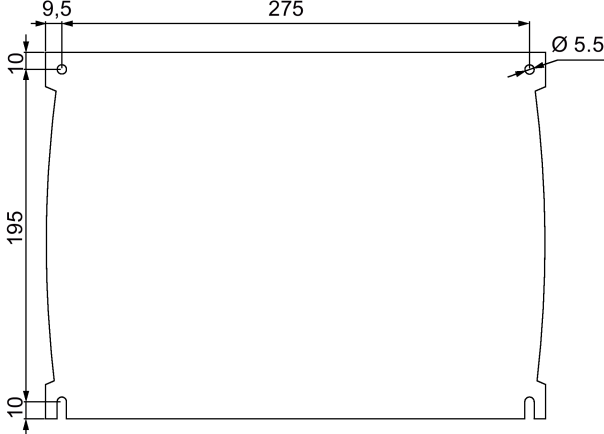
Step	Description
1	Find a flat surface for mounting the device.
2	Drill four holes for the screws. <div style="text-align: center;">  </div>
3	Secure the motor starter using four screws (M5). If necessary, use plain washers and spring washers. The tightening torque must not exceed a maximum of 2.5 Nm.

4.1.5 Connecting to functional ground

The motor starter must be connected to functional ground. The connection to functional ground is required to discharge interference and ensure EMC resistance. Unlike the protective conductor, functional ground does not offer protection against electric shock, which is why it must be routed separately.

The contact plate at the fixing point on the bottom right is connected to functional ground within the device. This connection must be connected to the ground potential with as little resistance as possible.

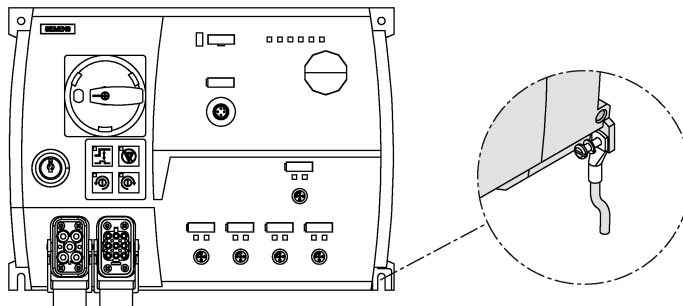

Figure 4-5 Connection for functional ground

If you do not install the motor starter on a grounded, conductive base, you have to establish a connection with the ground potential (grounding cable with cable lug, spring washer, and plain washer).

4.1.6 Setting the AS-i address

Unique addressing

In the factory setting, an I/O module (slave) has the address 0. It is detected by the master as a new slave that has not yet been addressed and, in this condition, has not yet been integrated in standard communication/data exchange.

To enable data to be exchanged between the master and slaves, you have to assign a unique address for each slave (i.e. each slave address must be different) when commissioning the AS-Interface network.

You can select any address in the address space from 1A to 31A and 1B to 31B. Thus a maximum of 62 nodes are possible in one AS-Interface network.

Where the M200D AS-i Standard motor starter is concerned, on account of the two slaves this means that you can operate a maximum of 31 devices on a master.

Addressing the slaves

You can set the slave address in different ways:

- Offline with the addressing unit at the AS-i connection.
Recommended if you want to assign addresses for the entire system. The direct connection between the slave (motor starter) and addressing unit ensures that the slaves are not mixed up.
- Online by the AS-i master or in the PLC configuration software.
Recommended if you want to assign addresses to individual slaves if an addressing unit is not available.
Before assigning addresses, you must ensure that each address exists only once in the AS-i network, that is, several new, additional modules (with address 0 in as-delivered condition) must not be connected to the AS-i cable.
- Online with Motor Starter ES (via optical interface, not via AS-Interface)

 **CAUTION**

As soon as you have assigned a valid address outputs can be set or inputs read that result in follow-up switching operations. To prevent a hazardous condition switch off the voltage U_{AUX} .

Offline addressing with the addressing unit





The motor starter is addressed via the AS-i connection socket.

Note

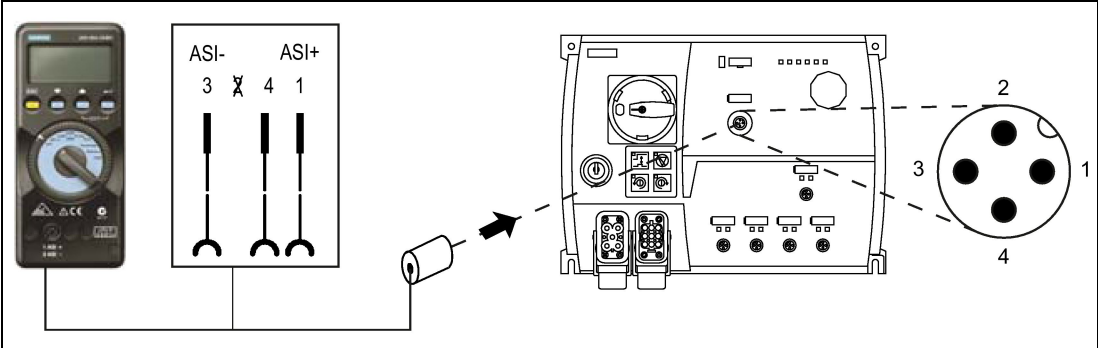
When assigning the address via the addressing unit, unscrew the encoders (sensors) from the digital inputs to prevent the addressing unit from being overloaded by their power consumption.

If the older version of the addressing unit (3RK1904-2AB00) is used, a special addressing cable (3RK1901-3RA00) is required to connect the module to the addressing unit.



1.	Connect the motor starter to the addressing unit (3RK1904-2AB02) using a standard M12 connection cable (2 or 3-pin) (e.g. 3RK1902-4PB15-3AA0). (4 or 5-pin connection cables must not be used for addressing purposes.)
2.	Address the motor starter. Set the selector switch to ADDR . Press  . The address of the connected motor starter is read and displayed. Select the address by choosing   . To transfer the address to the motor starter, choose  .
3.	Unplug the addressing cable and reconnect the motor starter using the AS-i cable.

Online addressing with the AS-i master and in the PLC configuration software

For instructions on how to address the motor starter using the AS-i master or in the configuration software, refer to the manual for the AS-i master you are using.

ID1 code

If required, set an ID1 code at this point as well.

This enables you to select a process image input assignment that is different from the default setting. See Input process image (Page 120).

4.1.7 Addressing the motor starter

The M200D AS-i Standard motor starter contains two separate logical AS-i slaves: Slave 1 and Slave 2. The diagram below illustrates the process by which these slaves are addressed.

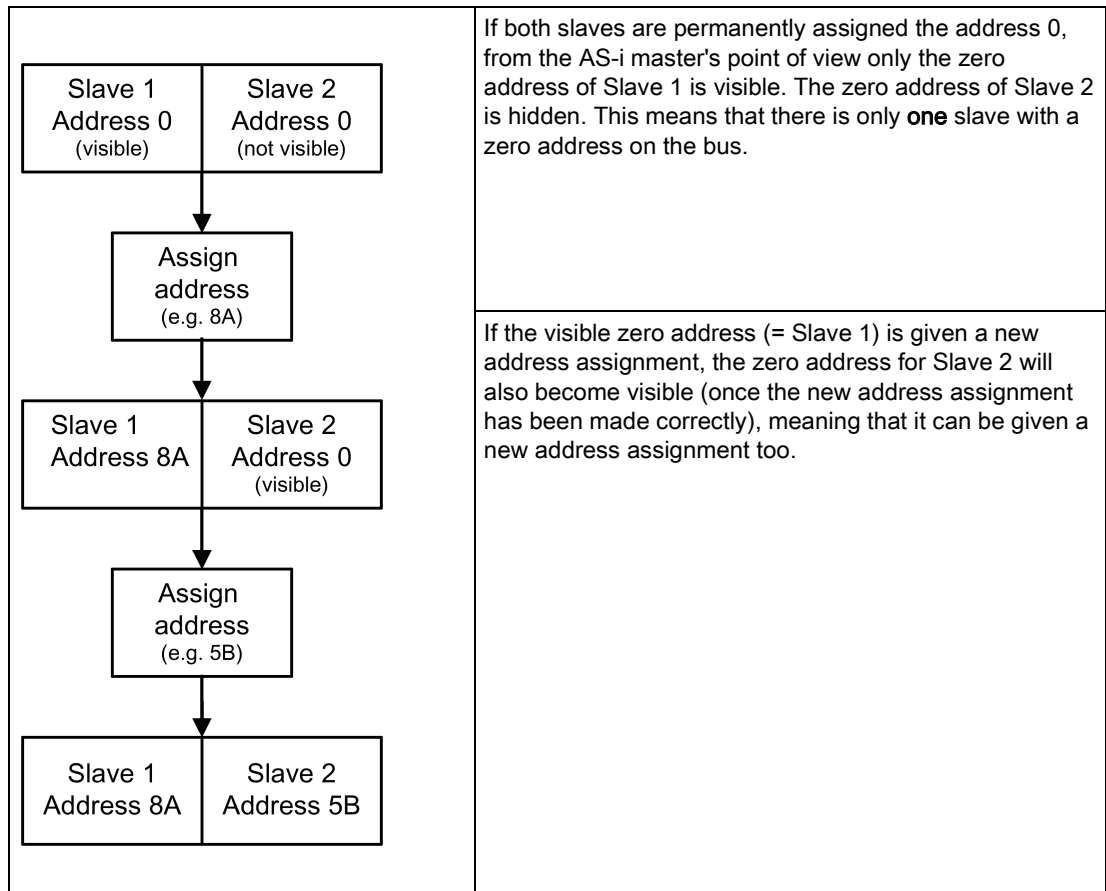

Note

If you assign the zero address to either of the two integrated slaves, the other one will automatically adopt the zero address as well. You should restart the motor starter once this has occurred.

Assigning a new address

When assigning a new address, only the address of the slave affected will be deleted. Once the new address is assigned, it is transferred to the slave. The other slave in each case remains unaffected by this.

4.2 Connecting

4.2.1 Solution Partner

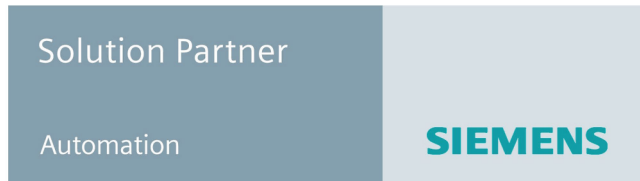

More connection technology products can be found in "Siemens Solution Partners" (www.siemens.com/automation/partnerfinder) under "Distributed Field Installation System".

The **Solution Partner Program** provides you with a complete range of connection methods in all the versions available from your preferred suppliers. This gives you the competitive edge with cost-effective cables in any length and design.

4.2.2 Required components/cables

Selecting the power cables

 DANGER
Hazardous Voltage Can Cause Death, Serious Injury, or Property Damage Before starting work, disconnect the system and devices from the power supply.

The cross-section of the power cables must be suitable for the prevailing ambient conditions. The following factors determine the cross-section:

- The current set on the device
- The cable installation type
- The ambient temperature
- The type of material (PVC, rubber)

The following maximum current-carrying capacities apply for PVC power cables when installed, for example, in the cable duct (depending on the ambient temperature):

Cross-section	T _U = 30 °C	T _U = 40 °C	T _U = 45 °C	T _U = 50 °C	T _U = 55 °C
1.5 mm ²	14 A	12.2 A	11.1 A	9.9 A	8.5 A
2.5 mm ²	19 A	16.5 A	15.0 A	13.5 A	11.6 A
4.0 mm ²	26 A	22.6 A	20.5 A	18.5 A	15.9 A
6.0 mm ²	33 A	28.7 A	26.1 A	23.4 A	18.2 A

Note

Unused connections

Seal unused connections by means of the sealing caps enclosed since this is the only way to ensure degree of protection IP65.

The sealing caps are also available as accessories:

Item	Quantity	Order no.
Sealing cap M12	10 pieces	3RK1901-1KA00

4.2.3 Prefabricating power cables

To prefabricate power cables, you require the following:

- A crimping tool for attaching the sockets and pins on the individual wires
- For infeed on motor starters
 - Assignment of X1: see section Power terminal (Page 100):
 - A flexible Cu cable with 4 x 2.5 mm² / 4 mm² / 6 mm² (3 wire + PE)
(for motor starters with 230 V AC brake output: 5-core cable; 3 wire + N + PE)
 - Han Q4/2 socket power connector

Item	Quantity	Order no.
Contact socket 2.5 mm ² , for Han Q4/2 sockets	5	3RK1911-2BE50
Contact socket 4 mm ² , for Han Q4/2 sockets	5	3RK1911-2BE10
Contact socket 6 mm ² , for Han Q4/2 sockets	5	3RK1911-2BE30
Crimping tool 4 / 6 mm ²	1	3RK1902-0CW00

Consumer connection on the motor starter

For the assignment of X2, see Power terminal (Page 100):

- A flexible Cu cable with 1.5 mm² or 2.5 mm²
 - Without brake control: 3 wire + PE
 - With brake control: 5 wire + PE
 - With temperature sensor: 2 additional wires
 - Han Q8/0 pin power connector

Item	Order no.
Connector set, 8 X 1.5 mm ² , 9 pin, complete with PG16 cable entry	3RK1902-0CE00
Connector set, 8 X 2.5 mm ² , 9 pin, complete with PG16 cable entry	3RK1902-0CC00

4.2.4 Installing and wiring power connectors

 DANGER
<p>Hazardous voltage Can Cause Death, Serious Injury, or Property Damage</p> <p>Before starting work, disconnect the system and devices from the power supply.</p>

Install and wire the power connectors as follows:

Step	Procedure	
1	Route the cable through the cable gland, sealing insert (enclosed), and the connector housing. The sealing insert is available in the following gradings:	
	Permissible external diameter of the cable	Sealing insert
	7.0 to 10.5 mm 9.0 to 13.0 mm 11.5 to 15.5 mm	Green Red White
2	Strip the cable over a length of 20 mm.	
3	Strip the cores over a length of 8 mm.	
4	Secure the contact sockets/pins on the cores by crimping or soldering them.	
5	Sort the contact sockets/pins in the socket/pin insert in accordance with the assignments (see section Power terminal (Page 100)). The contact sockets/pins should not engage yet. Make sure that they are correctly assigned. Push the contact sockets/pins into the socket/pin insert until they engage. Use a suitable tool to remove contact sockets/pins that have already been installed (Han Q4/2: 3RK1902-0AB00, Han Q8/0: 3RK1902-0AJ00).	
6	Make sure that the position of the coding is correct, pull the cable back, and secure the socket/pin insert in the connector housing using the cross-recessed screws enclosed.	
7	Secure the cable gland. When doing so, make sure that the cable is not twisted against the connector housing.	

4.2.5 Power terminal

Wiring X1 (power supply) and X2 (motor connection)

The supply voltage is fed via power connector X1.

The motor is supplied via power connector X2.

Note

When inserting the pin/female contact insert into the connector housing, make sure that the coding is positioned correctly.

	Pin	Connector X1	Socket X2 without brake	Socket X2 with 400 V / 230 V AC brake	Socket X2 with 180 V DC brake
	1	Phase L1	L1 out	L1 out	L1 out
	2	Phase L2	---	N (for 230 V AC brake)	---
	3	Phase L3	L3 out	L3 out	L3 out
	4	N	---	Brake L1 (switched)	Brake L1 (switched) "-"
	5	---	2)	2)	2)
	6	---	---	Brake L3 (direct, for 400 V AC brake)	Brake L3 (direct) "+"
	7	---	L2 out	L2 out	L2 out
	8	---	2)	2)	2)
	11	1)	---	---	---
	12	1)	---	---	---
		PE	PE	PE	PE

1) Connector monitoring

2) Temperature sensor

Power supply: Han Q4/2 socket (connection for X1)

	Socket	Assignment	
	1	Phase L1	
	2	Phase L2	
	3	Phase L3	
	4	N	
	11	Connector monitoring	
	12	Connector monitoring	
	PE (yellow/green)		

Note

When you use the "connector monitoring" function, you have to connect pin 11 to pin 12 in the connector.

Motor connection Han Q8/0 pin (connection for X2)

	Pin	Assignment	
	1	L1 out	
	2	N ¹⁾	
	3	L3 out	
	4	Brake L1 (switched) ¹⁾	
	5	Temperature sensor	
	6	Brake L3 (direct) ¹⁾	
	7	L2 out	
	8	Temperature sensor	
	PE (yellow/green)		

¹⁾ See brake variants

Brake variants

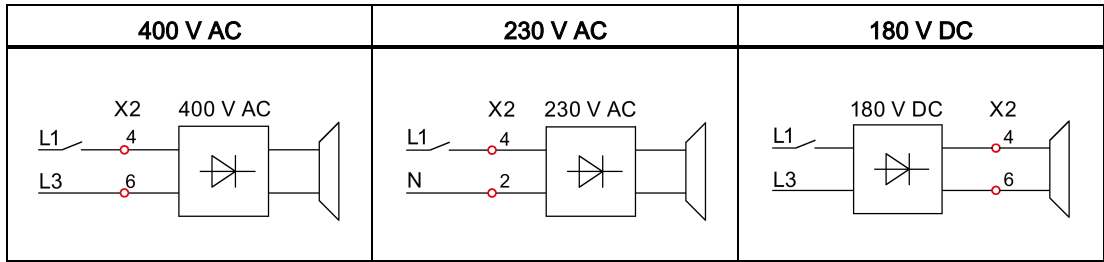

Note

Please note the different pin assignment in the case of the operating voltages of the brake.

4.2.6 Brake output

M200D motor starters can be equipped with an optional electronic brake control (order variant). The brake control is suitable for externally-supplied brakes with the coil voltages shown below:

- 400 V AC / 230 V

The brake rectifier must be installed in the motor. The rectifier input is controlled via the motor starter.

- 180 V DC

A rectifier is not required for the brake in the motor because the 180 V DC is provided by the motor starter. In this way, brake coils for 180 V DC can be switched directly.

The brake output for the M200D motor starter

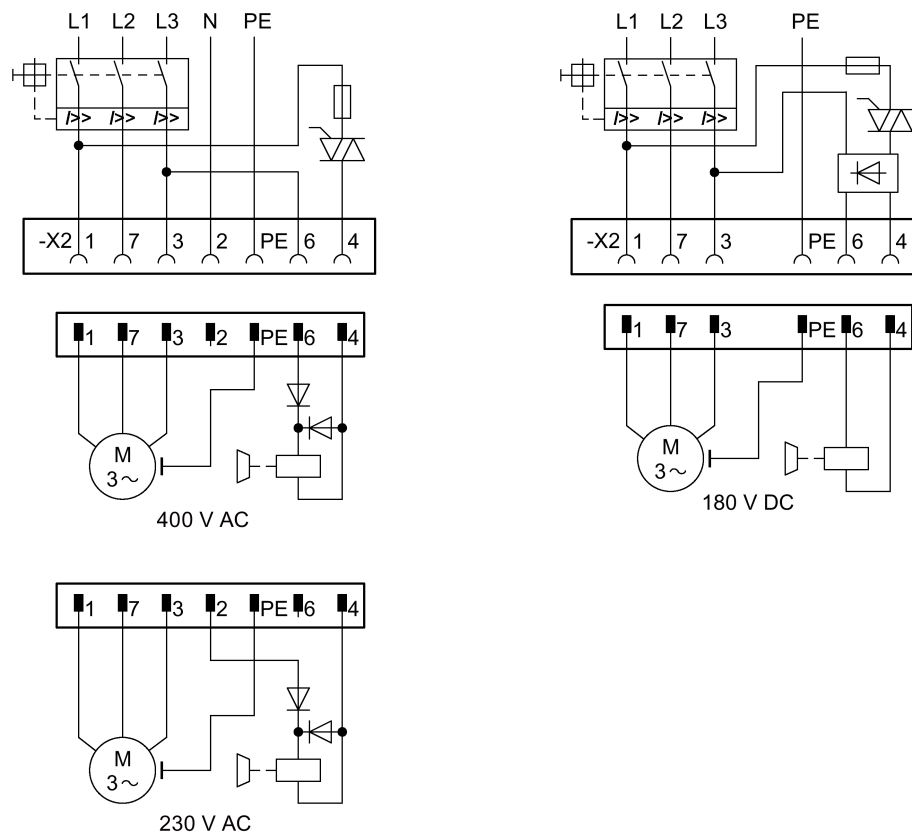

The brake voltage is fed to the motor together with the motor infeed via a joint cable (e.g. 6 x 1.5 mm²).

 WARNING
<p>Hazardous Voltage Can Cause Death or Serious Injury.</p> <p>The brake is only switched in a single phase. This therefore means that voltage can be applied at pin 6 even when the system is switched off.</p>

4.2.7 Inputs/outputs

Socket assignment

The digital inputs and output are equipped with standard 5-pin M12 sockets (A coding):

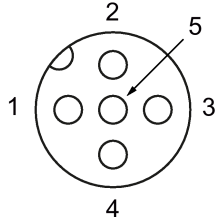
Assignment	Pin	Input	Output
	1	+ 24 V (PWR+)	N/C
	2	N/C	N/C
	3	0 V (PWR-)	0 V (PWR AUX-)
	4	Input signal (IN x)	Output signal (OUT 1)
	5	Functional ground (FE)	Functional ground (FE)

Note

Potential transfer

With AS-i, digital inputs must not be connected to digital outputs because this can establish an impermissible connection between the U_{AS-i} and U_{AUX} voltages.

4.2.7.1 Digital inputs IN1 to IN4 (A coding)

The motor starters are equipped with four digital inputs, which you can connect directly to sensors (PNP) (2 and 3-wire system).

Connectors (M12, 5-pin, A-coded) are used for this purpose. The motor starter is equipped with a range of sockets.

Note

Short-circuit hazard

Do not use an external power supply since this can result in a short-circuit.

Pin assignment

The following diagrams show examples of circuits (2 and 3-wire system):

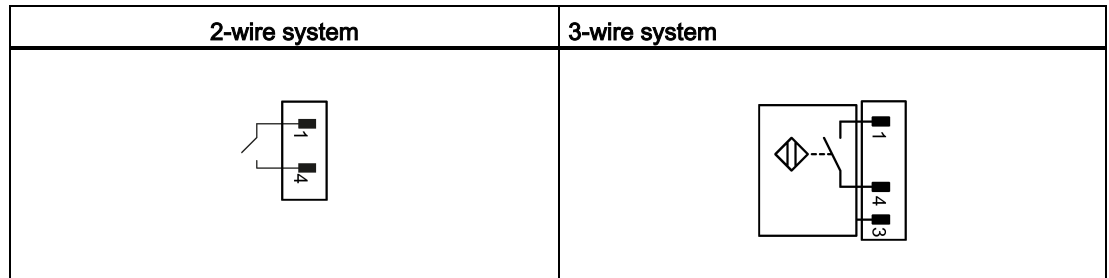

Note

The supply voltage for the digital inputs is short-circuit proof. The current is limited to max. 200 mA. If a short-circuit or overload situation occurs in the sensor supply, the switching element (motor) and brake output are shut down and a group fault is output. You must acknowledge this fault with a trip reset.

4.2.7.2 Digital output OUT1 (A coding)

The motor starter is equipped with a digital output, which you can connect directly to an actuator. The output is active when a group fault is present.

The output can be loaded to max. 0.5 A and protected electronically against short-circuits.

A connector (M12, 4 or 5-pin, A-coded) is used for establishing the connection. The motor starter is equipped with a range of sockets.

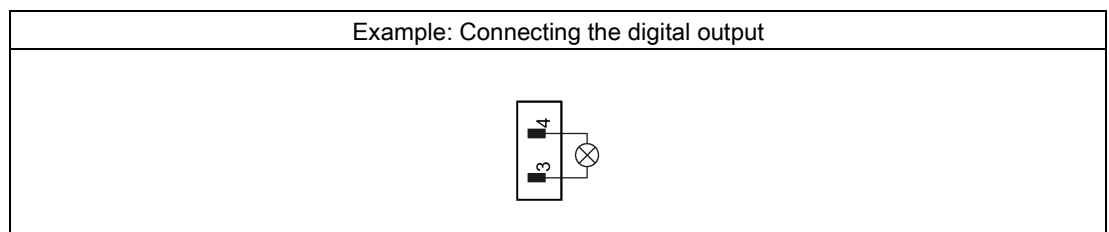

4.2.8 AS-Interface

Pin assignment

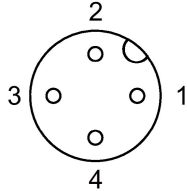
	Pin	Assignment
	1	U _{AS-i+}
	2	PWR-AUX -
	3	U _{AS-i-}
	4	PWR-AUX +

4.2.9 Connection options for AS-Interface

The different methods of connecting the motor starter to the AS-Interface bus cable and the 24 V DC auxiliary voltage are shown in the following table:

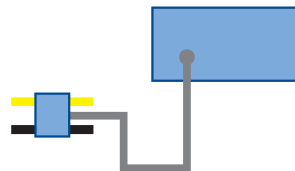
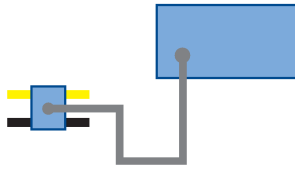
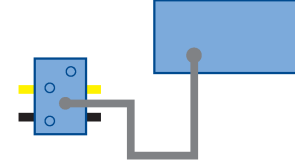
Motor starter	AS-i connection with U _{AUX}	
Plus M12 branch with integral cable		3RK1901-1NR21 (1 m) 3RK1901-1NR22 (2 m)
Plus M12 branch with socket plus separate M12 cable ¹⁾		3RK1901-1NR20
Plus 4 x M12 branch plus separate M12 cable ¹⁾		3RK1901-1NR00

1) These cables can be assembled from:
 3RK1 902-4GB50-4AA0 control cable, prepared at one end, M12 socket, angled with 5 m cable, max. 4 A and
 3RK1 902-4CA00-4AA0 M12 socket, angled for screw-type connection, 4-pin, max. 0.75 mm², A-coded, max. 4 A
 The cables can be replaced by:
 3RK1 902-4GB50-4AA0 control cable, prepared at one end, M12 socket, 5 m and
 3RK1 902-4CA00-4AA0 M12 socket, angled for screw-type connection, 4-pin, max. 0.75 mm², A-coded, max. 4 A

Connection examples for motor starters

The installation guidelines for AS-Interface must always be observed:

- The maximum permissible current for all M12 connection cables is restricted to 4 A. The cross-section of these cables is just 0.34 mm². To connect the motor starter, you can use the M12 connection cables mentioned above as spur lines.
- The voltage drop induced by the ohmic resistance (approx. 0.11 Ω/m) must be taken into account.
- The following maximum lengths apply to round cable connections in which AS-i and U_{AUX} are routed in the same cable:
 - For each spur line from the branch to the module: max. 5 m
 - Total of round cable components in one AS-Interface network: max. 20 m

AS-Interface M12 branches and distributor



Closed



Open

Note

If you are using a non-angled connector, you are advised to install the safety bars (accessories) to protect the AS-i connection against mechanical damage (refer to the Installing the safety bars (Page 92)).

Configuring/assigning parameters

5.1 Configuring

Configuring involves integrating the motor starter in the overall system by assigning addresses and parameters.

Master requirements

The M200D AS-i Standard motor starter requires an AS-i master to AS-i spec. 3.0, with master profile M4.

The table below lists AS-i masters that are M200D-compatible:

Designation	MLFB	Remark
CP 343-2	6GK7 343-2AH01-0XA0	1)
CP 343-2P	6GK7 343-2AH11-0XA0	1)
DP/AS-i Link 20E	6GK1 415-2AA10	1)
DP/AS-i Link Advanced	6GK1 415-2BA10 6GK1 415-2BA20	As of firmware version V2.0

1) With the CP 343-2(P) and DP/AS-i Link 20E, the extended process image (analog data) is accessed by reading a data set (data set no. 140-147; see the manual for the CP 343-2/Link 20E). The extended process image can only be accessed directly via I/O addresses ("Cyclic analog data") using the DP/AS-i Link Advanced.

For more details, please refer to Configuring on the DP/AS-i-Link Advanced (Page 110) in configuration step 9, as well as the documentation for the master.

5.2 AS-i profiles

M200D AS-i Standard motor starters contain 2 independent AS-i slaves in a single enclosure.

	Slave 1	Slave 2
IO code	7	7
ID code	A	A
ID2 code	5	E

You can find the AS-i profile setting in Configuring on the DP/AS-i-Link Advanced (Page 110).

You can find the data transfer assignments for the two slaves in Communication paths (Page 66).

5.2.1 ID1 code

You can use the ID1 code (Slave 2) to set the bit DI 1 assignment for the process image input (PII).

ID1 code	Meaning	Explanation
7 (default)	Motor on	0: OFF 1: ON (CW/CCW)
6	Automatic	0: Starter in "Manual" mode 1: Starter in "Automatic" mode
5	Group fault	0: No fault 1: Fault

You can change the ID1 code using the addressing unit or the Motor Starter ES software.

Note

Please note that the ID1 values set in the configuration software and on the device must match, otherwise the motor starter will not start up.

Note

If the ID1 code is changed, the new setting will only take effect once the motor starter has been restarted.

5.3 Configuring on the DP/AS-i Link Advanced

Standard starters contain 2 independent AS-i slaves (Slave 1 and Slave 2). Proceed as follows to configure these slaves on the DP/AS-i-Link Advanced.

Requirement

The AS-Interface Link Advanced is already configured on the PROFIBUS line.

Procedure

1. Click the Link Advanced module to open the AS-Interface module list.

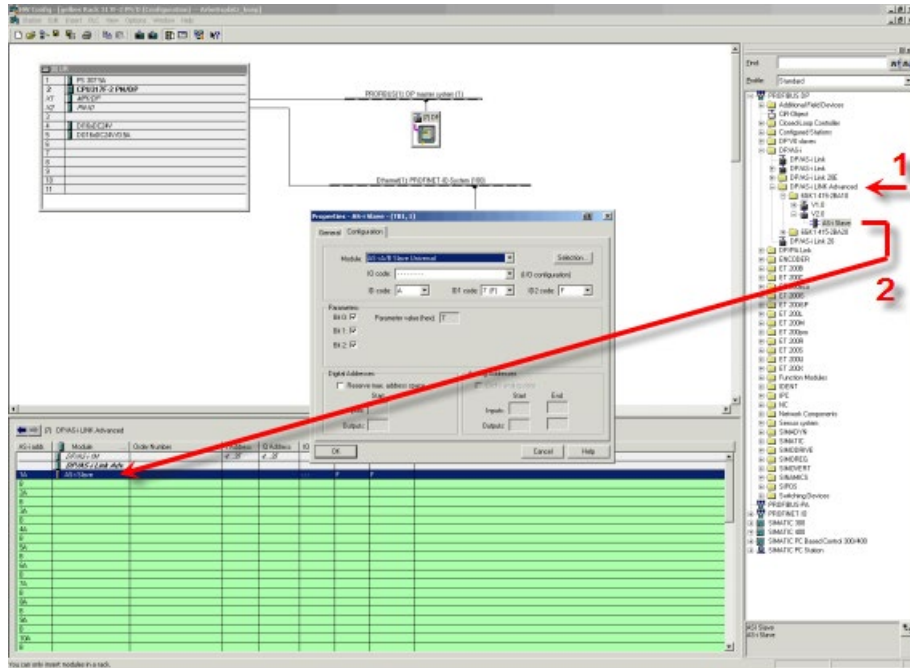

2. **Slave 1:**
To configure Slave 1, drag the "AS-i A/B Slave Universal" into this list from the list of modules in the DP-AS-i Link Advanced directory (e.g. into line 1A for AS-Interface address 1A).

(7) DP/AS-i LINK Advanced

AS-i addr.	Module	Order Number	I Address	Q Address	IO.ID.ID2
	DP/AS-i IM		4...35	4...35	
	DP/AS-i Link Adv.				
1A	AS-i Slave				
B					
2A					
B					
3A					
B					
4A					
B					
5A					
B					
6A					
B					
7A					
B					
8A					
B					
9A					
B					
10A					
B					

Open the object properties by double-clicking line 1A.

3. Change to the Configuration tab.
4. Click Selection... to open the slave selection box.
Select the AS-i A/B Slave Universal by double-clicking it

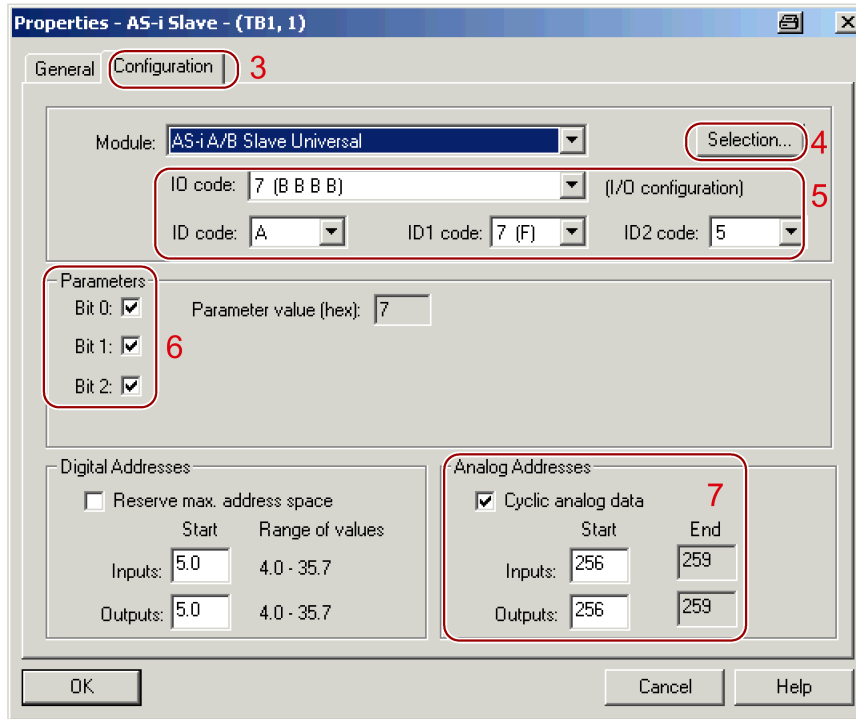

5. Enter the following values for the AS-i profile:

Field	Value
IO code:	7 (B B B B)
ID code:	A
ID1 code:	7 (F)
ID2 code:	5

6. Then enter the AS-i parameter bits at Slave 1:

P1 (bit 1): Extended process image

The extended process image contains important parameters (see the table titled Parameter overview (Page 116)). Transfer can be activated or deactivated using P1.

P2 (bit 2): In addition to the extended process image, parameters can be transferred acyclically via data sets (see the table titled Parameter overview). You use P2 to determine whether the M200D AS-i Standard waits for the parameter assignment data set on startup. (Default: Motor starter starts up without startup data sets.)

Field	Value
P bit 0	—
P bit 1	0: Extended process image activated 1: Extended process image deactivated (default setting)
P bit 2	Wait for "Parameter" startup data set 0: Yes, starter waits for parameter data set 1: No, starter starts up and uses the most recently valid parameter data set (default setting)

Note

If parameter bit P1 (bit 1) is activated and, therefore, the extended process image is deactivated, the analog addresses (extended process image) are not visible in the controller. In this case, settings in the analog data field (7) have no significance.

7. Entering analog addresses

The extended process image uses the AS-i mechanism for transferring analog data (for details, refer to the manual for the AS-i master). This data can be exchanged between the PLC and AS-i master either cyclically or acyclically. If you are using the cyclic transfer method, place a checkmark in the "Cyclic analog data" box. In the "Inputs" and "Outputs" entry fields, specify the address range for the analog data in the PLC address space.

- Cyclic transfer of I/O data

Select cyclic analog data.

Enter the required analog address, e.g. 256. You can use the "Cyclic analog data" check box to activate or deactivate access to analog data via I/O commands.

In the program, you access the analog input value of the first channel (IN1) using command L PIW256 and an analog output value (OUT1) using command T PQW256. The other channels of the module are located at the subsequent addresses, e.g. 258, 260, etc.

- Acyclic transfer of I/O data

If the "Cyclic analog data" check box is deselected, then the analog values are accessed via data sets. Therefore, the "Cyclic analog data" check box should not be selected if the analog outputs of an AS-i slave are written via acyclic services.

Slave 1 has now been configured.

8. **Slave 2:**

To configure Slave 2, repeat steps 1 to 4.

Please remember that the AS-i addresses must be different.

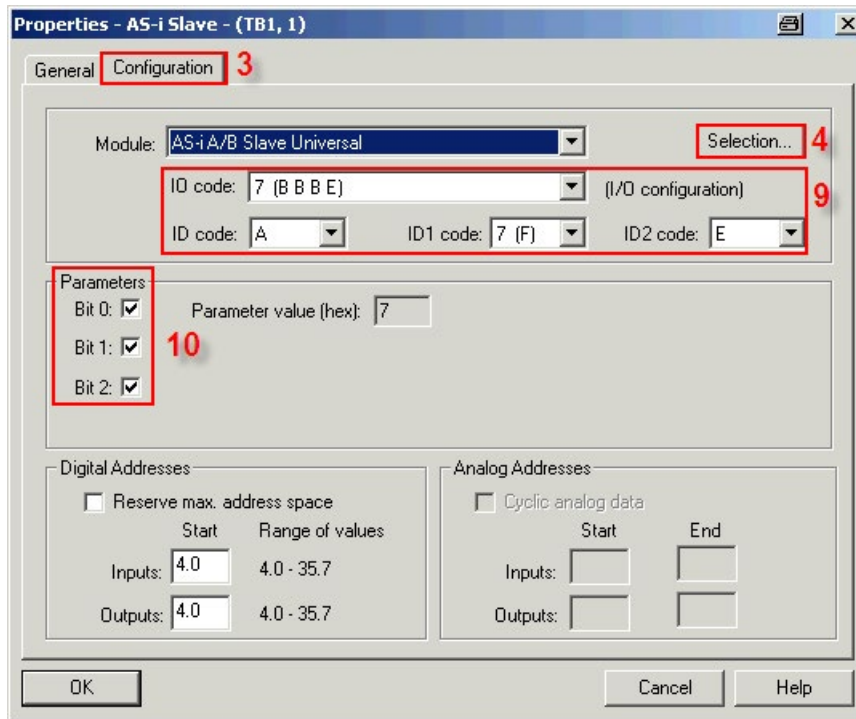

9. Enter the following values for the AS-i profile:

Field	Value
IO code:	7 (B B B E)
ID code:	A
ID1 code:	7 (F); alternatively 6 or 5 depending on the PII setting
ID2 code:	E

10. Then enter the AS-i parameter bits listed below.

Field	Value
P bit 0	0: Parameter echo = Messages/warnings 1: Parameter echo = Error/fault
P bit 1	—
P bit 2	—

Slave 2 has now been configured as well.

Integration in third-party controllers

The GSD file for the master is used to integrate the motor starter for operation on third-party controllers, with older versions of STEP 7, or with systems of types other than SIMATIC. The GSD file (device master data file) contains all the information required for communication between the CPU and AS-i master.

GSD file on the Internet

You can download the GSD file from the Internet (<http://support.automation.siemens.com/WW/view/de/113630>).

The process for integrating the GSD file is described in detail in the manuals for the third-party controllers.

5.4 Assigning parameters

The parameters for the motor starter can be assigned using the following:

- AS-i parameter bits
- Extended process image (cyclic CTT2 data; see Extended cyclic process image (Page 123))
- Data set DS 203, "Device parameters" (acyclic CTT2 data; see Data set 203 (Page 176))
- Motor Starter ES (via local device interface only)

5.4.1 Assigning parameters using AS-i parameter bits

The parameter bits are transferred from the master to Slave 1 via AS-i command "Write_Parameter" when the motor starter is started up or during operation. This data channel can be used to exchange measuring and setting data cyclically or parameters and diagnostic data acyclically (function: reading parameters).

Slave 1

Byte/bit	Meaning	
P bit 0	Free	—
P bit 1	Extended process image	0: Activated (starter waits for valid parameters) 1: Deactivated (default setting)
P bit 2	Wait for "Parameter" startup data set	0: Yes, starter waits for parameter data set 1: No, starter starts up and uses the most recently valid parameter data set (default setting)

5.4.2 Parameter overview

The table below provides an overview of all the M200D parameters and indicates which mechanism can be used to adjust each of the parameters.

Device parameter	Default setting	Setting range	Ext. PI	DS 203	Motor Starter ES
Rated operational current	<ul style="list-style-type: none"> In the motor starter: Maximum value In Motor Starter ES: Minimum value 	<ul style="list-style-type: none"> 0.15 A to 2.0 A 1.5 A to 9.0 A (only with soft starters in "direct" startup mode) 1.5 A to 12.0 A Increment: 10 mA	✓	✓	✓
Load type	3-phase	3-phase/1-phase	—	—	✓
Protection against voltage failure	Yes	Yes/no	—	—	✓
Response to switching element supply voltage cut-off	Group fault	<ul style="list-style-type: none"> Group fault Group fault only after ON command Group warning 	—	✓	✓
Response to CPU/Master STOP	Switch substitute value	Switch substitute value/hold last value	—	✓	✓
Group diagnostics	Block	Block/enable	✓	✓	✓
Wait for "Parameter" startup data set	No	Yes/no (can be set using the parameter bit during configuration)	—	—	—
Lock-out time	0	0 to 60 s Increment: 1 s	—	—	✓
Startup time (x 0.25 s)	5 s	0 to 30 s Increment: 0.25 s	—	✓	✓
Run-down time	0	0 to 30 s Increment: 0.25 s	—	✓	✓
Startup mode	Direct	<ul style="list-style-type: none"> Direct Voltage ramp Current limit Voltage ramp + current limit 	—	✓	✓
Run-down type	Run-down without load	<ul style="list-style-type: none"> Run-down without load Voltage ramp 	—	✓	✓
Starting voltage	40%	20% to 100% Increment: 5%	—	✓	✓
Stopping voltage	40%	20% to 90% Increment: 5%	—	✓	✓
Current limit value (x 3.125%)	<ul style="list-style-type: none"> 600% ($I_e \leq 9$ A) 450% ($I_e > 9$ A) 	125% to 600% Increment: 3.125%	—	✓	✓

Device parameter	Default setting	Setting range	Ext. PI	DS 203	Motor Starter ES
Brake release delay on starting	0 s	- 2.5 to + 2.5 s Increment: 0.01 s	—	✓	✓
Brake holding time on stopping	0 s	0 to 25 s Increment: 0.01 s	—	✓	✓
Response to overload - thermal motor model	Trip without restart	<ul style="list-style-type: none"> • Trip without restart • Trip with restart • Warning 	✓	✓	✓
Trip class (DSte/RSte, sDSSTe, sRSSSte in startup mode ≠ direct)	CLASS 10	<ul style="list-style-type: none"> • CLASS 5 (10a) • CLASS 10 • CLASS 15 • CLASS 20 • CLASS OFF 	—	✓	✓
Trip class (sDSSTe/sRSSSte in startup mode = direct)	<ul style="list-style-type: none"> • CLASS 10 in startup mode = direct • CLASS 5 (10a) in startup mode ≠ direct 	<ul style="list-style-type: none"> • CLASS 5 (10a) • CLASS 10 • CLASS OFF 	—	✓	✓
Recovery time (sDSSTe/sRSSSte only)	90 s	60 to 1,800 s Increment: 30 s	—	—	✓
Motor heating prewarning limit	0% (= deactivated)	0 to 95% Increment: 5%	—	✓	✓
Prewarning limit - remaining time for tripping	0 s (= deactivated)	0 to 500 s Increment: 1 s	—	—	✓
Idle time	0 s (= deactivated)	0 to 255 s Increment: 1 s	—	—	✓
Response to temperature sensor overload	Trip without restart	<ul style="list-style-type: none"> • Trip without restart • Trip with restart • Warning 	✓	✓	✓
Temperature sensor	Deactivated	<ul style="list-style-type: none"> • Deactivated • Thermoclick • PTC type A 	✓	✓	✓
Temperature sensor monitoring	Yes	<ul style="list-style-type: none"> • Yes • No 	—	✓	✓
Response to residual current detection	Trip	<ul style="list-style-type: none"> • Warning • Trip 	✓	✓	✓
Response to current limit violation	Warning	<ul style="list-style-type: none"> • Warning • Trip 	—	✓	✓

5.4 Assigning parameters

Device parameter	Default setting	Setting range	Ext. PI	DS 203	Motor Starter ES
Lower current limit	18.75%	<ul style="list-style-type: none"> 18.75 to 100% of I_e 0% (= deactivated) Increment: 3.125%	—	✓	✓
Upper current limit	112.5%	<ul style="list-style-type: none"> 50 to 150% of I_e 0% (= deactivated) Increment: 3.125%	—	✓	✓
Blocking current	800%	150 to 1,000% of I_e Increment: 50%	—	—	✓
Blocking time	1 s	1 to 5 s Increment: 0.5 s	—	—	✓
Response to asymmetry	Trip	<ul style="list-style-type: none"> Warning Trip 	✓	✓	✓
Asymmetry limit	30%	30 to 60% Increment: 10%	—	—	✓
Input signal extension	0 ms	0 to 200 ms Increment: 10 ms	—	—	✓
Input signal delay	10 ms	10 to 80 ms Increment: 10 ms	—	—	✓
Input 1 level	Normally open contact	<ul style="list-style-type: none"> Normally closed contact Normally open contact 	—	✓	✓
Input 2 level			—	✓	✓
Input 3 level			—	✓	✓
Input 4 level			—	✓	✓
Input 1 action	No action	<ul style="list-style-type: none"> No action Trip without restart Trip with restart Trip end position CW Trip end position CCW (RSte/sRSSSte only) Group warning Manual mode local Emergency start Motor CW Motor CCW (RSte/sRSSSte only) Quick stop Trip reset Cold run 	—	✓	✓
Input 2 action			—	✓	✓
Input 3 action			—	✓	✓
Input 4 action			—	✓	✓
Input 1 signal	Non-retentive	<ul style="list-style-type: none"> Retentive Non-retentive 	—	✓	✓
Input 2 signal			—	✓	✓
Input 3 signal			—	✓	✓
Input 4 signal			—	✓	✓

Device parameter	Default setting	Setting range	Ext. PI	DS 203	Motor Starter ES
Output 1 level	Non-inverted	<ul style="list-style-type: none"> Non-inverted Inverted 	—	✓	✓
Output 1 signal	Continuous signal	<ul style="list-style-type: none"> Continuous signal Flashing 	—	✓	✓
Output 1 action	Control source PIO-DO-1.0	<p>Control by means of external control source</p> <ul style="list-style-type: none"> Control source PIO-DO-1.0 Control source PIO-DO-1.1 Control source PIO-DO-0.2 Control source input 1 Control source input 2 Control source input 3 Control source input 4 <p>Control by means of external control source</p> <ul style="list-style-type: none"> Run-up Operation/shunting Coasting down On time motor (RUN) Control command motor ON Brake output Device ON <p>Control by means of messages from the motor starter</p> <ul style="list-style-type: none"> Group prewarning Group warning Group fault Bus error Device error Maintenance required Maintenance requested Ready for motor ON 	—	✓	✓
Connector monitoring	Line side	<ul style="list-style-type: none"> Deactivated Line side 	✓	✓	✓
Response when connector removed	Group fault	<ul style="list-style-type: none"> Group fault Group fault only after ON command Group warning 	✓	✓	✓
Response to circuit breaker OFF	Group fault	<ul style="list-style-type: none"> Group fault Group fault only after ON command Group warning 	✓	✓	✓

5.5 Process data and process image

5.5.1 Process image

Definition of process image

The process image is a component of the AS-i master system memory.

At the start of the cyclic program, the signal states of the inputs are transferred to the process image of inputs.

At the end of the cyclic program, the process image of the output is transferred to the slave as a signal state.

Input process image (PII)

The table below contains process data and a process image of inputs DI 0 to DI 3:

Slave 2

The PII assignment may change depending on the ID1 code.

Process image for ID1 = 7:

Byte/bit	Process image	Signal: 1 = HIGH, 0 = LOW
DI 0	Ready (automatic)	0: Starter not ready for host/PLC 1: Starter ready to be operated via host
DI 1	Motor on	0: OFF 1: ON (CW/CCW)
DI 2	Input 1 (input action: quick stop)	0: Not active 1: Active
DI 3	Input 2 (no action)	0: Not active 1: Active

Process image for ID1 = 6:

Byte/bit	Process image	Signal: 1 = HIGH, 0 = LOW
DI 0	Ready (automatic)	0: Starter not ready for host/PLC 1: Starter ready to be operated via host
DI 1	Automatic	0: Starter in "Manual" mode 1: Starter in "Automatic" mode
DI 2	Input 1 (input action: quick stop)	0: Not active 1: Active
DI 3	Input 2 (no action)	0: Not active 1: Active

Process image for ID1 = 5:

Byte/bit	Process image	Signal: 1 = HIGH, 0 = LOW
DI 0	Ready (automatic)	0: Starter not ready for host/PLC 1: Starter ready to be operated via host
DI 1	Group fault	0: No fault 1: Fault
DI 2	Input 1 (input action: quick stop)	0: Not active 1: Active
DI 3	Input 2 (no action)	0: Not active 1: Active

Note

The cyclic process data that is assigned depends on the ID1 setting for Slave 2. You can change the ID1 code using the addressing unit or the Motor Starter ES software. If you change it using the Motor Starter ES software, the cyclic message data is changed directly and the ID1 setting for Slave 2 is changed automatically within the slave.

If ID1 is changed, the new setting will only take effect following a restart.

Slave 1

Byte/bit	Process image	Signal: 1 = HIGH, 0 = LOW
DI 0	Input 3	0: Not active 1: Active
DI 1	Input 4	0: Not active 1: Active
DI 2	Reserved	—
DI 3	Reserved	—

Output process image (PIO)

The following table contains process data and a process image of outputs DO 0 to DO 3:

Slave 2

Byte/bit	Process image	Signal: 1 = HIGH, 0 = LOW
DO 0	Motor CW	0: Motor off 1: Motor on
DO 1	Motor CCW	0: Motor off 1: Motor on
DO 2	Disable quick stop	0: Not activated 1: Activated
DO 3	Reserved (A/B switchover)	—

Slave 1

Byte/bit	Process image	Signal: 1 = HIGH, 0 = LOW
DO 0	Reserved	—
DO 1	Reserved	—
DO 2	Digital output	0: Not activated 1: Activated
DO 3	Reserved (A/B switchover)	—

Reference

For more information about system integration and data management in the controller, refer to the "AS-Interface system" System Manual.

5.5.2 Extended cyclic process image via CTT2

Extended cyclic process image of outputs (PIO)

With M200D AS-i Standard motor starters, parameters are transferred from Slave 1 to the master on a continuous (cyclical) basis. This involves 4 bytes of data. These 4 bytes can be accessed from the user program in the same way as analog data is accessed.

Transfer from the master to the motor starter (slave) takes place serially via the CTT2 (Combined Transaction Type 2) protocol.

The parameters in the extended cyclic process image can only be used if the extended cyclic process image has been activated in the configuration (P1=0)

Please refer to the documentation for the AS-i master for detailed information on analog data transfer.

Extended process image (PIO) to starter			
Byte/bit pos.	Coding	Meaning	
Addr.+ 0			
Addr.+1			
	Unsign. 16	Rated operational current I _e	15 to 200 [x 10 mA] (0.15 to 2 A) 150 to 1,200 [x 10 mA] (1.5 to 12 A)
Addr.+2			
2.0	Bit 1	Group diagnostics	[0]: block [1]: Enable
2.1...2	Bit 2	Response to overload - thermal motor model	[0]: Trip without restart [1]: Trip with restart [2]: Warning
2.3...4	Bit 2	Temperature sensor	[0]: Deactivated [1]: Thermoclick [2]: PTC type A
2.5...6	Bit 2	Response to temperature sensor overload	[0]: Trip without restart [1]: Trip with restart [2]: Warning
2.7	Bit 1	Response to residual current detection	[0]: Warning [1]: Trip
Addr.+3			
3.0	Bit 1	Response to asymmetry	[0]: Warning [1]: Trip
3.1...2	Bit 2	Response to circuit breaker OFF	[0]: Group fault [1]: Group fault only after ON command [2]: Group warning
3.3	Bit 1	Connector monitoring	[0]: Deactivated [1]: Line side
3.4		Reserved	
3.5...6	Bit 2	Response when infeed connector removed	[0]: Group fault [1]: Group fault only after ON command [2]: Group warning
3.7		Reserved	

Extended cyclic process image of inputs (PII)

With M200D AS-i Standard starters, Slave 1 returns diagnostics data, messages, and measured values to the master or CPU on a continuous (cyclical) basis. This involves 4 bytes of data. These 4 bytes can be accessed from the user program in the same way as analog data is accessed. Transfer from the starter (slave) to the master takes place serially via the CTT2 protocol.

In this case, the extended cyclic process image of inputs can also be read out if it has not been activated during configuration (P1 = 1).

Please refer to the documentation for the AS-i master for detailed information on analog data transfer.

Extended process image (PII) from starter			
Byte/bit pos.	Coding	Meaning	
Transmit data			
Addr.+ 0			
0.0...7	Unsign. 8	Motor current I _{max} (%)	0 to 255 [x 3.125%]
Addr.+1			
1.0...6	Unsign. 6	Motor heating (%)	0 to 100 [x 2%]
1.7	Bit 1	Asymmetry >= 40%	1 = Active
Addr.+2			
2.0	Bit 1	Ready (automatic)	1 = Active
2.1	Bit 1	Motor CW	
2.2	Bit 1	Motor CCW	
2.3	Bit 1	Group fault	
2.4	Bit 1	Group warning	
2.5	Bit 1	Temperature sensor overload	
2.6	Bit 1	Thermal motor model overload	
2.7	Bit 1	Sensor supply overload	
Addr.+3			
3.0	Bit 1	Residual current detected	1 = Active
3.1	Bit 1	Asymmetry detected	
3.2	Bit 1	Circuit breaker open/tripped	
3.3	Bit 1	Connector removed on line side	
3.4	Bit 1	Manual mode local	
3.5	Bit 1	Invalid parameter value	
3.6	Bit 1	Free	
3.7	Bit 1	Free	

Reference

For more information about system integration and data management in the controller, refer to the "AS-Interface system" System Manual.

5.6 Motor Starter ES software

Properties

The Motor Starter ES diagnostics and commissioning tool (Version 2007 SP2 and higher) offers you the following:

- Structured, tool-based configuration of low-voltage switching devices
- Fast diagnostics
- Local commissioning and monitoring, such as:
 - Parameterization during operation of the controller and the control system
 - Monitoring
 - Diagnostics and testing
 - Factory settings
 - Read-out of individual phase currents as direct values
 - Residual current detection
 - Setting a parameter block function
 - Integrated online help
 - Read-out of statistical values and measured values

Motor Starter ES order number: 3ZS1310-5CC10-0YA5

Application

Motor Starter ES is operated via the local device interface.

The connection between the PC or programming device and the motor starter is established using an infrared RS232 PC cable for the optical device interface (see Local device interface (Page 83)).

Commissioning

6.1 Requirements

Parameter assignment

The motor starter parameters are assigned during startup using the AS-i Standard procedure. Parameters can be modified and HMI (operator control and monitoring) tasks performed during operation, either via the bus and the acyclic mechanism or locally via the optical device interface.

The "Group diagnostics" parameter can be set to "block" or "enable". If "block" is selected, no fault messages are sent.

A device error can only be acknowledged by switching the power off and then on again. If the errors occur repeatedly, however, this indicates that the motor starter is defective.

Trip reset (Page 77) can be used to acknowledge all other errors.

Note

Please be sure to observe the voltage tolerance for the load voltage supply (contactors and power electronics) up to 55 °C: 20.4 V to 28.8 V.

Rated operational current

The rated operational current for M200D motor starters is parameterized using the Motor Starter ES software or the extended process image (Page 68).

Disconnecting the load from the supply system

You can set the integral disconnecting means to the OFF position to disconnect the motor starter from the supply system.

NOTICE
Connecting/disconnecting a load during operation (that is, under load) is not permissible.

Reversing starter

Via the user program, make sure that before a change of direction takes place, the drive is switched to "STOP" long enough to come to a standstill.

Software requirements

Configuration software used	Explanations
Configuration software for the AS-i master used	See the manual for the AS-i master
Motor Starter ES configuration software	Order no.: 3ZS1310-5CC10-0YA5 For parameter assignment and operator control and monitoring tasks using a local device interface (see online help)

Commissioning requirements

Prior activity		For more information, see ...
1.	Motor starter installed	"Mounting" section
2.	Address set on motor starter	"Mounting" section
3.	Supply voltage for motor starter switched on	—
4.	Supply voltage for load switched on (if necessary)	See manual for motor
5.	Motor starter configured (configured and parameterized)	"Configuring/assigning parameters" section
6.	Supply voltage for AS-i master switched on	—
7.	AS-i master switched to RUN operating mode	Manual for AS-i master

6.2 M200D components

Minimum configuration

The overview shows the components you need for operation:

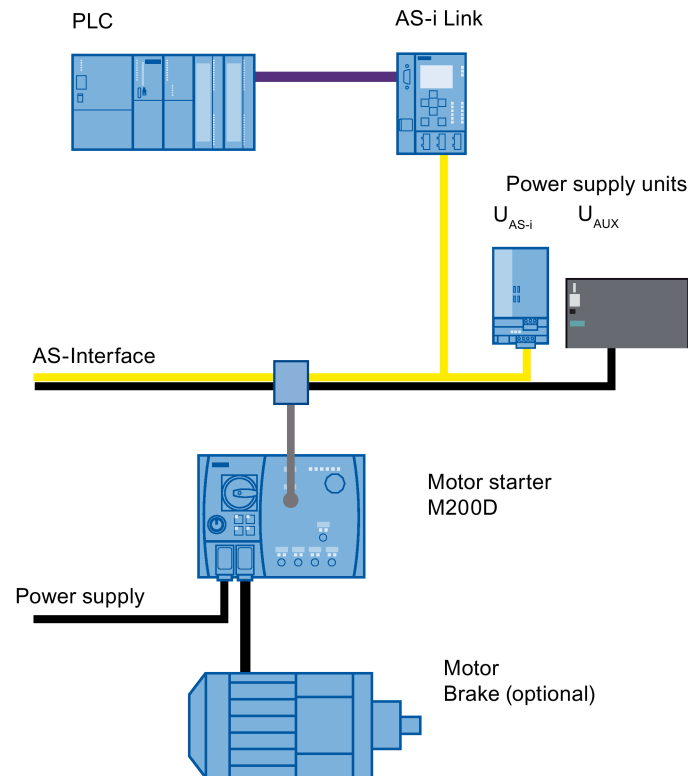

Figure 6-1 Minimum configuration of a motor controller

Required components

For this example, you need the following components:

- A higher-level controller (e.g. S7 series)
- A suitable AS-i master to AS-i specification 3.0 with profile M4
- The motor starter
- Power supply units for AS-Interface (U_{AS-i}) and the AS-i auxiliary voltage (U_{AUX})
- Connection material:
 - PLC \Rightarrow AS-i Link
 - AS-i branch M12 with a yellow AS-i cable and black auxiliary voltage cable or AS-i round cable M12 (with auxiliary power supply)
 - Power connection cable (X1)
 - Motor connection cable (X2)

6.3 Procedure

Commissioning procedure

The following chart shows a logical, step-by-step commissioning procedure.

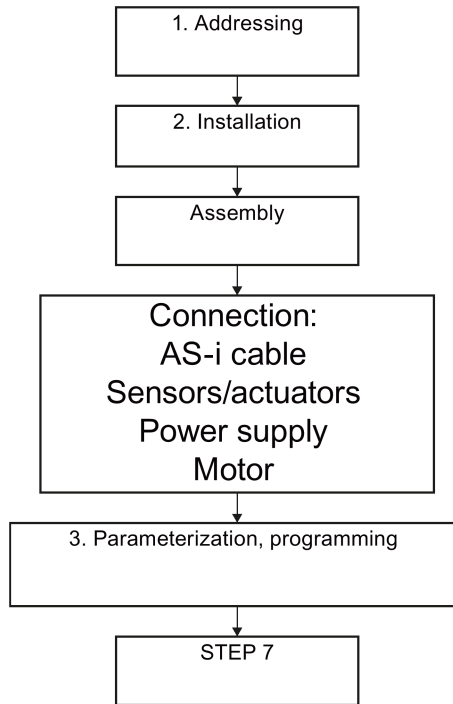

Figure 6-2 Commissioning procedure

Diagnostics

Diagnostics data can be read from the motor starter in a number of different ways:

- Diagnostics on the device:
 - Status LEDs
- Diagnostics via AS-Interface:
 - S1 bit in the AS-i status register (AS-i slave status)
 - Parameter echo after AS-i command "Write_Parameter"
 - P0 = 0 → messages, warnings
 - P0 = 1 → fault messages
- Additional diagnostics options:
 - Addressing and diagnostic unit
 - AS-Interface analyzer
 - Using Motor Starter ES via the device interface
 - Slave 1 analog values from the extended process image (PI1)
 - Acyclic transfer of data set DS 200

7.1 Diagnostics with LEDs

7.1.1 Statuses of the individual LEDs

The following LEDs indicate the status of the motor starter:

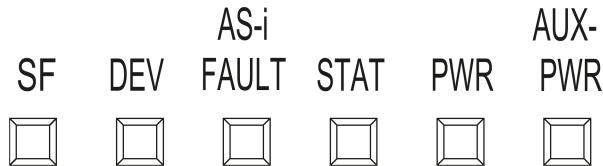

SF LED (possible colors: Red/OFF)

Status	Meaning	Dependencies
Off	No error/fault	—
Red	Device detects error/fault	Device error: <ul style="list-style-type: none"> • Current flowing with no ON command • Self-test error
		System error: <ul style="list-style-type: none"> • Current not flowing despite ON command (residual current detected) ¹⁾ • Internal tripping • External encoder supply short-circuit • No U_{AUX} • Thermal motor model overload ¹⁾ • Current limit violation ¹⁾ • No switching element supply voltage ¹⁾ • Group fault via input action • Connector monitoring ¹⁾ • Circuit breaker tripped/open ¹⁾
		Startup fault: <ul style="list-style-type: none"> • Startup parameter invalid
¹⁾ Depends on the parameter assignment		

DEVICE LED (possible colors: Red/green/yellow/OFF)

Status	Meaning	Cause
Off	Device not ready	System error: <ul style="list-style-type: none"> No supply voltage for electronics or power supply is < 18 V
Green	Device ready	—
Flashing green	Device not starting up	No startup parameters received
Yellow	Internal tripping	—
Flashing yellow	Group warning	Group warning due to: <ul style="list-style-type: none"> Current not flowing despite ON command (residual current detected) ¹⁾ Thermal motor model overload ¹⁾ Temperature sensor overload ¹⁾ Asymmetry Current limit violation ¹⁾ Group warning via input action Invalid parameter value Connector monitoring ¹⁾ Circuit breaker tripped/open ¹⁾ No switching element supply voltage ¹⁾
Red	Device defective	A device defect was detected during the self-test.
Flashing red	Self-test	Motor current flowing
Flickering red	Self-test	No current flow
	Factory settings	—
¹⁾ Depends on the parameter assignment		

AS-i/fault LED (possible colors: Red/green/OFF)

Status	Meaning	Cause
Off	Device not ready	<ul style="list-style-type: none"> No supply voltage for electronics Hardware fault in AS-i slave
Green	Device ready	Communication active, normal operation
Flashing red/yellow	Slave address = 0	—
Flashing red/green	I/O fault	S1 bit set and group diagnostics = enabled
Flashing red	Serious I/O fault	<ul style="list-style-type: none"> Hardware fault in AS-i slave
Red	No data exchange	<ul style="list-style-type: none"> Master in stop mode Slave not entered in LPS Slave has wrong IO/ID code Slave in reset status

STATE LED (possible colors: Red/green/yellow/OFF)

Status	Meaning	Cause
Off	No control	Switching element OFF
Green	Control	Switching element ON by means of controller or HMI
Flashing green	Control and motor in soft startup/soft run-down	Switching element ON with ramp operation (sDSSSte and sRSSSte only)
Flickering green	Manual mode local input controls	Switching element ON by means of input action
Flashing yellow	Mode fault	Switching element OFF Manual mode connection abort without reset to automatic mode
Flickering yellow	Manual mode local input controls	Switching element OFF by means of input control function (e.g. quick stop)
Red	Switching element defective	Switching status ≠ switching command

PWR LED (possible colors: Green/OFF)

Status	Meaning	Cause
Off	No U _{AS-i}	No AS-i voltage
Green	U _{AS-i} present	AS-i voltage present

PWR-AUX LED (possible colors: Green/OFF)

Status	Meaning	Cause
Off	No U _{AUX}	No auxiliary voltage
Green	U _{AUX} present	Auxiliary voltage present

Input LEDs IN1 to IN4 (possible colors: Green/OFF)

Status	Meaning	Cause
Off	No 24 V DC	No input signal
Green	24 V DC present	Input signal present

Output LED OUT1 (possible colors: Green/OFF)

Status	Meaning	Cause
Off	No 24 V DC	No output signal
Green	24 V DC present	Output signal present

7.1.2 LED display combinations

You can detect certain faults/errors more accurately by looking at the combination of display statuses.

Device status/mode

SF LED	STATE LED	DEVICE LED	Device status/mode
Off	Green	Green	Motor ON; no fault/error
Off	Off	Green	Motor ON; no fault/error
Off	Flashing green	Green	Motor in soft startup; no fault/error (sDSSSte, sRSSSte only)
Off	Flashing green	Green	Motor in soft run-down; no fault/error (sDSSSte, sRSSSte only)
Off	Flickering green	Green	Motor ON; input controls
Off	Flashing yellow	Green	Manual mode connection abort without reset to automatic mode
Off	Flickering yellow	Green	Tripping by means of input control function (e.g. quick stop)
Off	Off	Flickering red	Self-test in progress (can only be called via Motor Starter ES)
Off	Off	Flashing green	No startup parameters received

Device errors

Note

Acknowledging device errors

A device error can only be acknowledged by switching the power off and then on again.

If the error occurs again, however, the motor starter will need to be replaced.

SF LED	STATE LED	DEVICE LED	Device error
Red	Red	Red	Current flowing with no ON command (e.g.: contactor welded, thyristor fused)
Red	Off	Red	Electronics defective, self-test error
Red	Off	Off	No connection with AS-i

System error/Warning

SF LED	STATE LED	DEVICE LED	System error/Warning
Red	Off	Yellow	<ul style="list-style-type: none"> • Current not flowing despite ON command (residual current detected) ¹⁾ • Internal tripping • No switching element supply voltage ¹⁾ • External encoder supply short-circuit • No U_{AUX} • Thermal motor model overload ¹⁾ • Current limit violation ¹⁾
Off	Green (when switching element is ON)	Flashing yellow	Group warning due to: <ul style="list-style-type: none"> • Current not flowing despite ON command (residual current detected) ¹⁾ • Thermal motor model overload ¹⁾ • Temperature sensor overload ¹⁾ • Asymmetry • Current limit violation ¹⁾ • Group warning via input action • Invalid parameter value • Connector monitoring ¹⁾ • Circuit breaker tripped/open ¹⁾ • No switching element supply voltage ¹⁾
Off	Off	Off	No supply voltage for electronics
¹⁾ Depends on the parameter assignment			

Group fault

SF LED	STATE LED	DEVICE LED	Group fault
Red	Off	Off	Device diagnostics available <ul style="list-style-type: none"> • No switching element supply voltage ¹⁾ • Group fault via input action • Connector monitoring ¹⁾ • Circuit breaker tripped/open ¹⁾
¹⁾ Depends on the parameter assignment			

7.2 Diagnostics via parameter channel (parameter echo)

Diagnostics (diagnostic message and diagnostic read procedure)

In the PLC, you can tell whether a fault has occurred by looking at the "I/O fault bit" (S1) on the slave status tab. The AS-i master enters the S1 value in the list of I/O faults (LPF) that have been signaled. The PLC can read this list via the "GET_LPF" command and then signal a specific diagnostic value from the slave.

Slave diagnostics echo (parameter echo)

Bit P0 defines whether a fault diagnosis (P0 = 1) or warning/message diagnosis (P0 = 0) is returned to the master as a slave response.

The parameter value (P0 = (0/1); P1 = x; P2 = x; P3 = x) is sent to the master via the "Write_Parameter" command.

Output of messages / alarms in order of priority

In the parameter echo, only one fault or message is output at any one time; this is always the one with the highest priority. No further messages/faults can be output while this message/fault is present.

A diagnosis is only returned for Slave 2.

Call (AS-i master to motor starter M200D):			
P3	P2	P1	P0
A/B switchover ¹⁾	x (any state)	x (any state)	0

1) automatically set by the system

Call (motor starter M200D to AS-i master):						
Parameter echo - warnings (W) / messages (M)						
P3	P2	P1	P0	Decimal	Message/Warning	Priority
0	0	0	0	00	No warning/message	16
0	0	0	1	01	(M) No external startup parameters received	1
0	0	1	0	02	(W) Main circuit breaker OFF	3
0	0	1	1	03	(W) Residual current warning	6
0	1	0	0	04	(M) Thermal motor model deactivated	9
1	0	0	0	08	(W) Overload	4
1	0	0	1	09	(W) Connector removed on line side	2
1	0	1	0	10	(M) Manual local control	8
1	0	1	1	11	(W) Prewarning limit of motor model exceeded	7
1	1	0	0	12	(M) Temperature sensor deactivated	10
1	1	0	1	13	(W) Asymmetry warning	5
1	1	1	0	14	(W) Input action group warning	11
1	1	1	1	15	(W) Group warning	12

Call (AS-i master to motor starter M200D):			
P3	P2	P1	P0
A/B switchover ¹⁾	x (any state)	x (any state)	1

1) automatically set by the system

Call (motor starter M200D to AS-i master):						
Parameter echo - fault (F)						
P3	P2	P1	P0	Decimal	Fault	Priority
0	0	0	0	00	No fault	16
0	0	1	0	02	(F) Main circuit breaker OFF	7
0	0	1	1	03	(F) Residual current tripping	10
0	1	0	0	04	(F) Overload	8
0	1	0	1	05	(F) Device error	1
0	1	1	0	06	(F) No switching element supply voltage	3
1	0	0	1	09	(F) Connector removed on line side	5
1	0	1	0	10	(F) Electronics supply voltage too low	2
1	1	0	0	12	(F) Short-circuit trip	6
1	1	0	1	13	(F) Asymmetry tripping	9
1	1	1	0	14	(F) Invalid parameter value	4
1	1	1	1	15	(F) Group fault	11

See also

Assigning parameters using AS-i parameter bits (Page 115)

7.3 Sample program

Diagnostics via parameter channel

Sample program: Slave diagnostics echo (parameter echo). The standard function ASi_3422 (FC7) of the AS-i master (PROFIBUS-ASi) is used for this purpose in the following sample program.

Alternatively, an ASI_Control function block (FB19) can be used for this task. You can find this block on the Siemens Service&Support pages (<http://support.automation.siemens.com/WW/view/de/51678777>).

For a description of the ASi_3422 block, please refer to the manual for the AS-i master (DP-ASi Link, CP 343-2). This also describes the call interfaces and commands.

Block ASi_3422 must be called up once when the system is restarted (OB100).

Call in OB100:

```
CALL "ASi_3422"
  ACT      :=FALSE                // not required
  STARTUP :=TRUE
  LADDR    :=W#16#14              // I/O address AS-i master
  SEND     := P#M 4.0 BYTE 1      // irrelevant
  RECV     := P#M 4.0 BYTE 1      // irrelevant
  DONE     :=M19.2
  ERROR    :=M19.3
  STATUS   :=MD24
```

To read out the parameter echo, the "Write_Parameter" command must be sent to the M200D motor starter.

Structure of the "Write_Parameter" command:

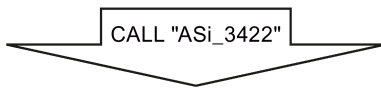
Structure of the job data in the send buffer				
Byte	Meaning			
	Bit 7	Bit 4	Bit 3	Bit 0
0	Command number: 02H			
1	Slave address (AS-i address that is to be read out of the diagnostics) ¹⁾			
2	0		AS-i parameter bits P 0 ... P3	
				
Structure of the job data in the receive buffer				
Byte	Meaning			
	Bit 7	Bit 4	Bit 3	Bit 0
0	0		Parameter echo	

1) Value range of the slave address: 1A to 31A ≙ 1 to 31; 1B to 31B ≙ 33 to 63

With this command, however, all 4 parameter bits (P0 to P3) must be sent to the starter.

In the parameters that have been read out, parameter P0 can now be changed as required.

Sample program:

```
// Parameters in memory byte MB4
  SET
  R    M    4.0           // read messages/warnings from starter
                          //: Bit P0 = 0

// or
  SET
  S    M    4.0           // read faults from starter: Bit P0 = 1
// trigger parameter echo
// command for SEND buffer
  L    2                 // "Write_Parameter" command
  T    MB    2
  L    2                 // slave address of starter
  T    MB    3

// job parameters are in MB4
// write parameters to starter: "Write_Parameter_Value"
// create job for SEND buffer:
CALL  "ASi_3422"
  ACT    :=M10.4         // trigger for writing parameters
  STARTUP:=FALSE        // not required in cycle
  LADDR  :=W#16#14      // address of AS-i master
  SEND   :=P#M 2.0 BYTE 3 // command data range
  RECV   :=P#M 6.0 BYTE 1 // range for response
  DONE   :=M10.5
  ERROR  :=M10.6
  STATUS :=MD16
// parameter echo stored in MB6
```

7.4 Diagnostics with the addressing and diagnostics unit

Diagnostics functions

The addressing and diagnostics unit (order no.: 3RK1904-2AB02) features a range of diagnostics functions, such as:

- Detecting incorrect polarity or overload
- Measuring the AS-i supply voltage
- Detecting faults (with comments)
- Displaying I/O faults

For more information, refer to the operating instructions for the addressing and diagnostics unit.

7.5 Troubleshooting

7.5.1 Response to faults

Description

In some cases, the device can be set in such a way that it responds to faults by either issuing a warning or by tripping. Examples: "Response to asymmetry", "response to temperature sensor overload".

The following table shows how the motor starter responds (depending on how it has been parameterized):

	Fault	
	Response 1	Response 2
Response:	Warning	Trip
Message bit:	Group warning set	Group fault set
LED display:	DEVICE flashes yellow	DEVICE lights up yellow SF lights up red
Motor and brake:	Not shut down	Shut down

Note

With certain faults (e.g. "process image error" or device errors, such as "Switching element defective"), however, the device always responds by tripping. This response cannot be changed!

Other methods of indicating faults

Faults in the system can also be indicated as follows:

- When using Motor Starter ES, the relevant fault message appears in plaintext.
- On the fieldbus, the relevant bis is set in the cyclic message frame and/or on the diagnostics channel.

7.5.2 Acknowledging faults

Switching back on after device-internal tripping

If the motor starter trips the switching elements automatically, it will not switch back on until:

- The fault has been rectified
- The fault has been acknowledged
- The "Emergency start" device function has been activated; that is, the motor can be switched on and off using the control commands in spite of a pending group fault (not in the case of a device error!)

Acknowledging

You can acknowledge faults as follows:

- With "trip reset"
 - DO0 and DO1 simultaneously (motor CW and motor CCW)
 - "Trip reset" command
 - "Trip reset" input action
 - Key-operated switch (order variant) in position O
 - Circuit breaker 0 → 1
 - Device interface (hand-held device, Motor Starter ES)
- "Tripping with restart" (auto reset) parameterized
- With the opposite command, e.g. "motor OFF" (process image errors only)

Note

Trip reset is edge-triggered!

If trip reset is present permanently, acknowledgement is only triggered once.

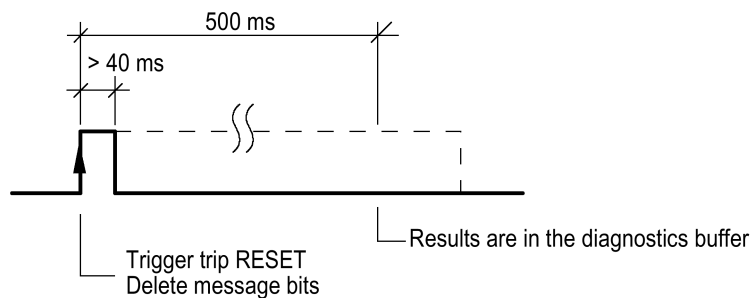

Technical data

8.1 General technical specifications

Location	In the plant	Wall mounted (near motor)	
Permissible mounting positions		Vertical, horizontal, flat	
Degree of protection	IP65 Type 12	According to IEC 529 (DIN 40050) According to UL	
Protection class	1	IEC 60364-4-41 (DIN VDE 0100-410)	
Touch protection	Finger-safe		
Degree of pollution	3	To IEC 60664	
Cooling	Convection	No additional cooling required	
Operating temperature	-25°C to + 40°C max. 55°C	With reduction of I _e (see "Derating")	
Transport and storage temperature	-40°C to + 70°C	—	
Air humidity	10 % to 95 %	Condensation must not be allowed to form	
Max. temperature change	1 K / min	IEC 60068, Part 2-14	
Chemical environment conditions	3C3	conforming to IEC 60721-3-3	
Installation altitude	1000 m 2000 m	No restrictions With restrictions (reduction of I _e by 1 % every 100 m up to 2000 m)	
Vibration resistance	2 g	To IEC 60 068, Part 2-6	
Shock	12 g with 11 ms without influencing point of contact: 9.8 g / 5 ms or 5.9 g / 10 ms	To IEC 60 068, Part 2-27 half-sine	
Free fall	0.6 m	In product packaging	
ESD	8 kV air discharge 4 kV contact discharge	IEC 61000-4-2	Severity grade 3
Electromagnetic fields	10 V/m	IEC 61000-4-3	Severity grade 3
BURST	2 kV / 5 kHz supply voltage 2 kV / 5 kHz data cables 2 kV / 5 kHz process cables	IEC 61000-4-4	Severity grade 3
SURGE Installation class 1 to 3 ¹⁾	1 / 2 kV	IEC 61000-4-5	Severity grade 3
Emitted interference	Limit value class A	EN 55011	

¹⁾ If the starter is used in installation class 3 (increased overvoltage due to parallel cable installation), an overvoltage protection module (3RK1901-1GA00 and 3RG9030-0AA00) must be used.

Note

This product is designed for environment A (industrial environments). In household environments, this device can cause unwanted radio interference. The user may be required to implement appropriate measures in this case.

8.2 Motor starters

Motor starter version		DSte/RSte	sDSSSte/sRSSSte
Installation dimensions in mm (in parentheses: with safety bars)	Width		294 (320)
	Height		215 (228)
	Depth		159 (230)
Weight (g)		2,880 g/3,130 g	3,220 g/3,420 g
Control circuit (AS-i interface)			
Slave type			A/B slave
Suitable for AS-i master to spec.... (or higher)			AS-i Spec. 3.0 (M4)
AS-i slave profile IO.ID.ID2			7.A.E and 7.A.5
ID1 code (factory setting)			7
Total power consumption from AS-i			
without connected sensors			max. 100 mA
with connected sensors			max. 300 mA
			(total sensor current consumption <200mA)
Current consumption from U _{AUX} at 24 V (without digital output)		Max. 155 mA Typ. 75 mA	Max. 15 mA / 175 mA Typ. 10 mA / 75 mA
Main circuit			
Power of three-phase motors at 400 V		5.5 kW	5.5 kW
Rated operational current I _e C			
AC-1/2/3	At 400 V	12 A	—
	At 500 V	9 A	—
AC-4	At 400 V	4 A	—
AC-53a (8 h operation)	At 400 V	—	12 A (soft start) 9 A (direct start)
Rated operational voltage			
Certification to EN 60947-1 Appendix N		400 V AC, 50/60 Hz	400 V AC, 50/60 Hz
Certification to UL508 and CSA C22.2 No. 14		600 V AC, 50/60 Hz	480 V AC, 50/60 Hz
Product category according to UL		NLDX	NMFT
Motor ratings according to UL / CSA			
3RK13.5- .K (2 A) power (3ph /hp) / max. FLA	for 460/480 V AC	3/4 hp / 1.6 A	3/4 hp / 1.6 A
	for 575/600 V AC	1 hp / 1.7 A	—
3RK13.5- .K (12 A) power (3ph /hp) / max. FLA	for 230/240 V AC	3 hp / 9.6 A	2 hp / 6.8 A
	for 460/480 V AC	7.5 hp / 11 A	5 hp / 7.6 A

Motor starter version	DSte/RSte	sDSSSte/sRSSSte
Typ. switching times incl. internal signal processing at 0.85 to 1.1 x U _e	- Closing delay - Opening delay	25 / 105 ms 35 / 35 ms
Mechanical service life of contactor	30 million	—
Electrical service life of contactor	See Electrical service life of contactor (Page 156)	—
B10 value		1000000 ¹⁾
Permissible switching frequency	See Electrical service life of contactor (Page 156)	See Switching frequency (Page 148)
Isolation stability		
Rated impulse withstand voltage U _{imp}		6 kV
Rated insulation voltage U _i		500 V
Safe isolation between main and control circuits to IEC 60947-1 Appendix N		400 V
Short-circuit protection		
Instantaneous overcurrent release		
- I _{e max} = 2 A		26 A
- I _{e max} = 9/12 A		208 A
Rated short-circuit-breaking capacity I _{cu} at 400 V in accordance with IEC 60947		
at 400 V	50 kA	50 kA
at 500 V	50 kA	20 kA
Short circuit ratings according to UL / CSA	65 kA / 480 V / Any circuit breaker or any fuse	5 kA / 480 V / Fuse: 60 A class J
	10 kA / 600 V / Any circuit breaker or any fuse	42 kA / 480 V / Fuse: 45 A class J
Group installation	Suitable for Group installation	
Motor disconnect	Suitable as motor disconnect	

1) This specification refers exclusively to the mechanical switching element under its reference conditions.

Note

To reverse the direction of rotation, a mechanically-switching reversing contactor is integrated in reversing starters with electronic switching. The preferred position of this contactor is "CW rotation". When the direction is changed to "CCW rotation", the reversing contactor is activated first, followed by the electronic contacts after an 80 ms delay.

8.3 Brake control

Brake version	400 V AC / 230 V	180 V DC
Rated operating voltage	AC 220 ... 600 V (-10% / +5%), 50 / 60 Hz	
Output voltage	-	0.45 x U _e e. g. 180 V DC at 400 V AC 215 V DC at 480 V AC
Shutdown delay	-	50 ms
Continuous current	< 0.5 A	< 0.8 A
Voltage drop during continuous current	7 V	3.5 V
Inrush current at t < 120 ms	< 5 A	< 5 A
Switching capacity to IEC60947-5-1		
- AC 15, at 400 V AC	0.4 A	-
- DC 13, at 180 V DC	-	0.8 A
Fault message with non-controlled brake	No	
Protective measures		
Short-circuit protection	Yes, 1 A melting fuse	
Inductive interference protection	Integrated varistors	
Max. energy absorption of switching voltage limit	> 43 J (for 2 ms)	

8.4 Inputs

Input characteristic to IEC60947-1 Appendix S and IEC61131-2	Type 1
Input voltage	- Rated value - for signal "0" - for signal "1"
	24 V DC -3 to +5 V 11 to 30 V
Input current for signal "1"	7 mA, typ.
Connection of 2-wire BEROs	Possible
Permissible residual current	1.5 mA, max.
Input signal delay	10 ms to 80 ms, can be parameterized
Supply from U _{AS-i}	Short-circuit and overload proof
Sensor supply	16.5 to 30 V DC
Total current sensor supply	Max. 200 mA (sensor supply is short-circuit proof)
Connection	M12 connector (A-coded)
Assignment of inputs	
IN1	Input 1 (DI2) ¹⁾
IN2	Input 2 (DI3) ¹⁾
IN3	Input 3 (DI0) ²⁾
IN4	Input 4 (DI1) ²⁾
1)	Slave 2
2)	Slave 1

8.5 Output

Number of digital outputs		1
Cable length	Shielded Unshielded	30 m, max.
Short-circuit protection		Electronic
Response threshold		> 0.7 A, typ.
Limiting of inductive shutdown voltage		Integrated freewheeling diode
Lamp load		5 W, max.
Switching capacity		0.5 A continuous current
Controlling an AS-i digital input		Not permissible
Voltage drop	For signal 1	$U_{AUX} + (-0.8 \text{ V})$, min.
Residual current	For signal 0	0.5 mA max.
Connection		M12 connector (A-coded)
Assignment of output		
OUT1		Output 1 (DO2) ¹⁾
¹⁾ Slave 1 (dependent on "Output n action" parameter)		

8.6 Thermistor motor protection

Temperature sensor		PTC	Thermoclick
Evaluation characteristic to IEC 60947-8		Type A	—
Summation cold resistance sensor circuit			< 1.5 k Ω
No-load voltage of sensor circuit			< 30 V
Short-circuit current sensor circuit			< 1.2 mA
Trip level			3.4 ... 3.8 k Ω
Reset level			1.5 ... 1.65 k Ω
Short-circuit detection		< 30 Ω	No
Electrical isolation vis-à-vis	Main circuit		Yes ($U_i = 400 \text{ V}$)
	U_{AS-i}		Yes ($U_i = 400 \text{ V}$)
	U_{PWR}		Yes ($U_i = 400 \text{ V}$)

8.7 Switching frequency

The switching frequency specifies how many switching cycles can be performed in one time unit (e.g. in 1 hour) with the switching device under normal operating conditions.

If motors are switched too often, this causes the thermal motor model to respond.

The maximum permissible switching frequency depends on the following operating data:

- Rated current I_e of the motor
- On time motor
- Degree and type of protection
- Ambient conditions such as
 - Temperature
 - Mounting position

On time motor

The relative on time in % is the ratio between the load duration and the cycle duration on loads that are switched on and off frequently.

The on time can be calculated using the following formula:

$$ED = \frac{t_s + t_b}{t_s + t_b + t_p}$$

ED ON duration [%]

t_s Starting time [s]

t_b Operating time [s]

t_p Idle time [s]

Graphics-based representation:

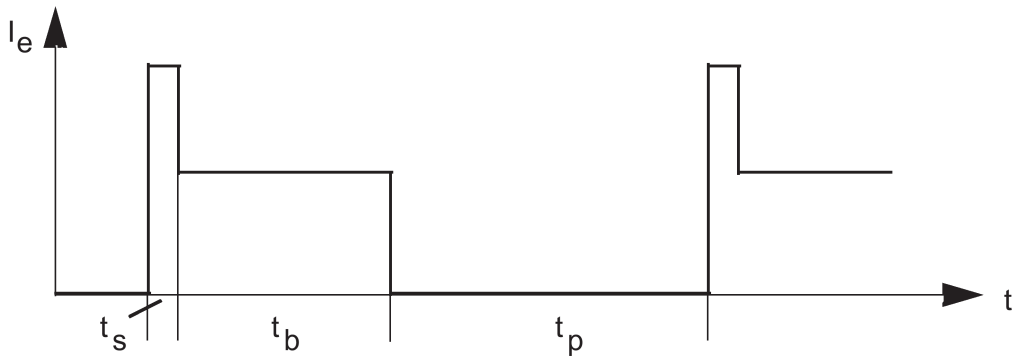

Figure 8-1 On time motor

The tables below provide an overview of the switching cycles/hour according to influencing factors.

Direct and reversing starters, electronic (sDSte / sRSte) up to 5.5 kW

Switching frequencies with active soft start function

Switching cycles/hour for 3RK1325-6KS71-AA. (0.15 A to 2 A)													
Mounting position	Vertical						Horizontal						
Rated current I_e	2 A		2 A		2 A		2 A		2 A		2 A		
Ambient temperature	40 °C		50 °C		55 °C		40 °C		50 °C		55 °C		
Motor protection	1)	2)	1)	2)	1)	2)	1)	2)	1)	2)	1)	2)	
Class 5 (10a)													
On time = 30%, start 4 x $I_e/1$ s	250	910	250	910	250	910	250	910	250	910	250	910	
On time = 70%, start 4 x $I_e/1$ s	150	460	150	460	150	460	150	460	150	460	150	460	
On time = 30%, start 4 x $I_e/2$ s	120	420	120	420	120	420	120	420	120	420	120	420	
On time = 70%, start 4 x $I_e/2$ s	70	210	70	210	70	210	70	210	70	210	70	210	
Class 10													
On time = 30%, start 4 x $I_e/2$ s	120	450	120	450	120	450	120	450	120	450	120	450	
On time = 70%, start 4 x $I_e/2$ s	70	230	70	230	70	230	70	230	70	230	70	230	
On time = 30%, start 4 x $I_e/4$ s	60	210	60	210	60	210	60	210	60	210	60	210	
On time = 70%, start 4 x $I_e/4$ s	37	100	37	100	37	100	37	100	37	100	37	100	
Class 15													
On time = 30%, start 4 x $I_e/3$ s	80	300	120	450	120	450	120	450	120	450	120	450	
On time = 70%, start 4 x $I_e/3$ s	50	150	70	230	70	230	70	230	70	230	70	230	
On time = 30%, start 4 x $I_e/6$ s	40	140	60	210	60	210	60	210	60	210	60	210	
On time = 70%, start 4 x $I_e/6$ s	25	70	37	100	37	100	37	100	37	100	37	100	
Class 20													
On time = 30%, start 4 x $I_e/4$ s	60	220	60	220	60	220	60	220	60	220	60	220	
On time = 70%, start 4 x $I_e/4$ s	37	110	37	110	37	110	37	110	37	110	37	110	
On time = 30%, start 4 x $I_e/8$ s	30	100	30	100	30	100	30	100	30	100	30	100	
On time = 70%, start 4 x $I_e/8$ s	18	50	18	50	18	50	18	50	18	50	18	50	

1) Duty cycle current rms value = $1.15 \times I_e \rightarrow$ motor protection

2) Duty cycle limit for motor starter. The motor should be protected against overload here by means of a thermistor.

8.7 Switching frequency

Switching cycles/hour for 3RK1325-6LS71-AA.(1.5 A to 12 A)												
Mounting position	Vertical						Horizontal					
Rated current I_e	5 A		5 A		5 A		5 A		5 A		4.5 A	
Ambient temperature	40 °C		50 °C		55 °C		40 °C		50 °C		55 °C	
Motor protection	1)	2)	1)	2)	1)	2)	1)	2)	1)	2)	1)	2)
Class 5 (10a)												
On time = 30%, start 4 x $I_e/1$ s	250	910	250	780	250	650	250	860	250	650	250	650
On time = 70%, start 4 x $I_e/1$ s	150	460	150	400	150	300	150	460	150	280	150	280
On time = 30%, start 4 x $I_e/2$ s	120	420	120	370	120	320	120	420	120	320	120	320
On time = 70%, start 4 x $I_e/2$ s	70	210	70	190	70	150	70	210	70	140	70	140
Class 10												
On time = 30%, start 4 x $I_e/2$ s	120	450	120	380	120	320	120	430	120	320	120	320
On time = 70%, start 4 x $I_e/2$ s	70	230	70	180	70	130	70	230	70	140	70	140
On time = 30%, start 4 x $I_e/4$ s	60	210	60	190	60	160	60	210	60	160	60	160
On time = 70%, start 4 x $I_e/4$ s	37	100	37	100	37	70	37	100	37	70	37	70
Class 15												
On time = 30%, start 4 x $I_e/3$ s	80	300	80	250	80	220	80	280	80	210	80	210
On time = 70%, start 4 x $I_e/3$ s	50	150	50	130	50	100	50	150	50	95	50	95
On time = 30%, start 4 x $I_e/6$ s	40	140	40	130	40	110	40	140	40	105	40	105
On time = 70%, start 4 x $I_e/6$ s	25	70	25	65	25	50	25	70	25	50	25	50
Class 20												
On time = 30%, start 4 x $I_e/4$ s	60	220	60	190	60	160	60	210	60	160	60	160
On time = 70%, start 4 x $I_e/4$ s	37	110	37	100	37	70	37	115	37	70	37	70
On time = 30%, start 4 x $I_e/8$ s	30	100	30	95	30	80	30	105	30	80	30	80
On time = 70%, start 4 x $I_e/8$ s	18	50	18	50	18	35	18	50	18	35	18	35

1) Duty cycle current rms value = $1.15 \times I_e \rightarrow$ motor protection

2) Duty cycle limit for motor starter. The motor should be protected against overload here by means of a thermistor.

Switching cycles/hour for 3RK1325-6LS71-AA.(1.5 A to 12 A)												
Mounting position	Vertical						Horizontal					
Rated current I_e	7 A		5.8 A		5 A		6 A		5 A		4.5 A	
Ambient temperature	40 °C		50 °C		55 °C		40 °C		50 °C		55 °C	
Motor protection	1)	2)	1)	2)	1)	2)	1)	2)	1)	2)	1)	2)
Class 5 (10a)												
On time = 30%, start 4 x $I_e/1$ s	250	580	250	600	250	650	250	650	250	650	250	650
On time = 70%, start 4 x $I_e/1$ s	150	260	150	260	150	300	150	280	150	280	150	280
On time = 30%, start 4 x $I_e/2$ s	120	290	120	300	120	320	120	320	120	320	120	320
On time = 70%, start 4 x $I_e/2$ s	70	130	70	130	70	150	70	140	70	140	70	140
Class 10												
On time = 30%, start 4 x $I_e/2$ s	120	290	120	300	120	320	120	320	120	320	120	320
On time = 70%, start 4 x $I_e/2$ s	70	130	70	130	70	130	70	140	70	140	70	140
On time = 30%, start 4 x $I_e/4$ s	60	145	60	150	60	160	60	160	60	160	60	160
On time = 70%, start 4 x $I_e/4$ s	37	65	37	65	37	70	37	70	37	70	37	70
Class 15												
On time = 30%, start 4 x $I_e/3$ s	80	190	80	200	80	220	80	210	80	210	80	210
On time = 70%, start 4 x $I_e/3$ s	50	85	50	85	50	100	50	95	50	95	50	95
On time = 30%, start 4 x $I_e/6$ s	40	95	40	100	40	110	40	105	40	105	40	105
On time = 70%, start 4 x $I_e/6$ s	25	45	25	45	25	50	25	50	25	50	25	50
Class 20												
On time = 30%, start 4 x $I_e/4$ s	60	145	60	150	60	160	60	160	60	160	60	160
On time = 70%, start 4 x $I_e/4$ s	37	65	37	65	37	70	37	70	37	70	37	70
On time = 30%, start 4 x $I_e/8$ s	30	72	30	75	30	80	30	80	30	80	30	80
On time = 70%, start 4 x $I_e/8$ s	18	33	18	33	18	35	18	35	18	35	18	35

1) Duty cycle current rms value = $1.15 \times I_e \rightarrow$ motor protection

2) Duty cycle limit for motor starter. The motor should be protected against overload here by means of a thermistor.

8.7 Switching frequency

Switching cycles/hour for 3RK1325-6LS71-AA.(1.5 A to 12 A)												
Mounting position	Vertical						Horizontal					
Rated current I_e	9 A		9 A		9 A		9 A		9 A		9 A	
Ambient temperature	40 °C		50 °C		55 °C		40 °C		50 °C		55 °C	
Motor protection	1)	2)	1)	2)	1)	2)	1)	2)	1)	2)	1)	2)
Class 5 (10a)												
On time = 30%, start 4 x $I_e/1$ s	250	340	250	250	210	210	250	290	210	210	170	170
On time = 70%, start 4 x $I_e/1$ s	150	290	150	200	150	160	150	240	150	170	125	125
On time = 30%, start 4 x $I_e/2$ s	120	170	120	120	105	105	120	145	105	105	88	88
On time = 70%, start 4 x $I_e/2$ s	70	140	70	100	70	80	70	120	70	82	63	63
Class 10												
On time = 30 %, start 4 x $I_e/ 2$ s	120	170	120	120	105	105	120	145	105	105	88	88
On time = 70 %, start 4 x $I_e/ 2$ s	70	140	70	100	70	80	70	120	70	82	63	63
On time = 30%, start 4 x $I_e/ 4$ s	60	85	60	60	53	53	60	72	53	53	44	44
On time = 70 %, start 4 x $I_e/ 4$ s	38	72	38	50	38	38	38	60	38	41	31	31
Class 15												
On time = 30 %, start 4 x $I_e/ 3$ s	80	115	80	85	70	70	80	97	71	71	58	58
On time = 70%, start 4 x $I_e/3$ s	50	95	50	65	50	52	50	80	50	55	42	42
On time = 30%, start 4 x $I_e/6$ s	40	57	40	42	35	35	40	48	35	35	29	29
On time = 70%, start 4 x $I_e/6$ s	26	48	26	33	26	26	25	40	25	27	21	21
Class 20												
On time = 30%, start 4 x $I_e/4$ s	60	85	60	60	53	53	60	72	53	53	44	44
On time = 70%, start 4 x $I_e/4$ s	38	72	38	50	38	38	38	60	38	41	31	31
On time = 30%, start 4 x $I_e/8$ s	30	42	30	30	26	26	30	36	26	26	22	22
On time = 70%, start 4 x $I_e/8$ s	18	36	18	25	18	18	19	30	19	20	15	15

- 1) Duty cycle current rms value = $1.15 \times I_e \rightarrow$ motor protection
- 2) Duty cycle limit for motor starter. The motor should be protected against overload here by means of a thermistor.

Switching cycles/hour for 3RK1325-6LS71-AA.(1.5 A to 12 A)												
Mounting position	Vertical						Horizontal					
Rated current I_e	12 A		12 A		12 A		12 A		12 A		11 A	
Ambient temperature	40 °C		50 °C		55 °C		40 °C		50 °C		55 °C	
Motor protection	1)	2)	1)	2)	1)	2)	1)	2)	1)	2)	1)	2)
Class 5 (10a)												
On time = 30%, start 4 x $I_e/1$ s	215	215	155	155	125	125	175	175	125	125	120	120
On time = 70%, start 4 x $I_e/1$ s	150	150	100	100	70	70	125	125	70	70	70	70
On time = 30%, start 4 x $I_e/2$ s	107	107	77	77	63	63	88	88	63	63	60	60
On time = 70%, start 4 x $I_e/2$ s	70	80	50	50	35	35	62	62	36	36	33	33
Class 10												
On time = 30%, start 4 x $I_e/2$ s	107	107	77	77	63	63	88	88	63	63	60	60
On time = 70%, start 4 x $I_e/2$ s	70	80	50	50	35	35	62	62	36	36	33	33
On time = 30%, start 4 x $I_e/4$ s	54	54	38	38	31	31	44	44	31	31	31	31
On time = 70%, start 4 x $I_e/4$ s	38	40	25	25	18	18	31	31	18	18	18	18
Class 15												
On time = 30%, start 4 x $I_e/3$ s	72	72	52	52	42	42	59	59	42	42	40	40
On time = 70%, start 4 x $I_e/3$ s	50	54	34	34	24	24	41	41	24	24	24	24
On time = 30%, start 4 x $I_e/6$ s	36	36	26	26	21	21	29	29	21	21	20	20
On time = 70%, start 4 x $I_e/6$ s	25	27	17	17	12	12	20	20	12	12	12	12
Class 20												
On time = 30%, start 4 x $I_e/4$ s	54	54	38	38	31	31	44	44	31	31	31	31
On time = 70%, start 4 x $I_e/4$ s	38	40	25	25	18	18	31	31	18	18	18	18
On time = 30%, start 4 x $I_e/8$ s	27	27	19	19	15	15	22	22	15	15	15	15
On time = 70%, start 4 x $I_e/8$ s	18	20	12	12	9	9	15	15	9	9	9	9

1) Duty cycle current rms value = $1.15 \times I_e \rightarrow$ motor protection

2) Duty cycle limit for motor starter. The motor should be protected against overload here by means of a thermistor.

Switching frequencies with deactivated soft start function (direct start)

Switching cycles/hour for 3RK1325-6LS71-AA.(1.5 A to 12 A)														
Mounting position	Vertical						Horizontal							
	2 A		2 A		2 A		2 A		2 A		2 A			
Rated current I _e	40 °C		50 °C		55 °C		40 °C		50 °C		55 °C			
Ambient temperature	1)	2)	1)	2)	1)	2)	1)	2)	1)	2)	1)	2)	1)	2)
Motor protection	1)	2)	1)	2)	1)	2)	1)	2)	1)	2)	1)	2)	1)	2)
Class 5 (10a)														
On time =30% (8 x I _e) / 0.1 s	600	3600	600	3600	600	3600	600	3600	600	3600	600	3600	600	3600
On time =70% (8 x I _e) / 0.1 s	360	2000	360	2000	360	2000	360	2000	360	2000	360	2000	360	2000
On time =30% (8 x I _e) / 0.2 s	300	2000	300	2000	300	2000	300	2000	300	2000	300	2000	300	2000
On time =70% (8 x I _e) / 0.2 s	180	1000	180	1000	180	1000	180	1000	180	1000	180	1000	180	1000
On time =30% (8 x I _e) / 0.4 s	150	1000	150	1000	150	1000	150	1000	150	1000	150	1000	150	1000
On time =70% (8 x I _e) / 0.4 s	90	520	90	520	90	520	90	520	90	520	90	520	90	520
Class 10														
On time =30% (8 x I _e) / 0.1 s	600	3600	600	3600	600	3600	600	3600	600	3600	600	3600	600	3600
On time =70% (8 x I _e) / 0.1 s	360	2000	360	2000	360	2000	360	2000	360	2000	360	2000	360	2000
On time =30% (8 x I _e) / 0.2 s	300	2000	300	2000	300	2000	300	2000	300	2000	300	2000	300	2000
On time =70% (8 x I _e) / 0.2 s	180	1000	180	1000	180	1000	180	1000	180	1000	180	1000	180	1000
On time =30% (8 x I _e) / 0.4 s	150	1000	150	1000	150	1000	150	1000	150	1000	150	1000	150	1000
On time =70 % (8 x I _e) / 0.4 s	90	500	90	500	90	500	90	500	90	500	90	500	90	500
On time =30 % (8 x I _e) / 0.8 s	75	490	75	490	75	490	75	490	75	490	75	490	75	490
On time =70 % (8 x I _e) / 0.8 s	45	250	45	250	45	250	45	250	45	250	45	250	45	250

1) Duty cycle current rms value = 1.15 x I_e → motor protection

2) Duty cycle limit for motor starter. The motor should be protected against overload here by means of a thermistor.

Switching cycles/hour for 3RK1325-6LS71-AA.(1.5 A to 12 A)												
Mounting position	Vertical						Horizontal					
Rated current I_e	5 A		5 A		5 A		5 A		5 A		4.5 A	
Ambient temperature	40 °C		50 °C		55 °C		40 °C		50 °C		55 °C	
Motor protection	1)	2)	1)	2)	1)	2)	1)	2)	1)	2)	1)	2)
Class 5 (10a)												
On time =30% (8 x I_e) / 0.25 s	240	1300	240	1000	240	800	240	1150	240	840	240	840
On time =70 % (8 x I_e) / 0.25 s	150	800	150	500	150	350	150	650	150	380	150	380
On time =30 % (8 x I_e) / 0.5 s	120	700	120	500	120	400	120	580	120	430	120	430
On time =70 % (8 x I_e) / 0.5 s	70	380	70	270	70	200	70	340	70	200	70	200
Class 10												
On time =30% (8 x I_e) / 0.25 s	240	1300	240	1000	240	820	240	1100	240	820	240	820
On time =70% (8 x I_e) / 0.25 s	160	760	160	500	160	350	160	640	160	350	160	350
On time =30 % (8 x I_e) / 0.5 s	120	700	120	520	120	420	120	580	120	430	120	430
On time =70 % (8 x I_e) / 0.5 s	70	400	70	280	70	200	70	340	70	200	70	200
On time =30 % (8 x I_e) / 1 s	60	350	60	260	60	220	60	290	60	220	60	220
On time =70 % (8 x I_e) / 1 s	37	190	37	140	37	100	37	170	37	100	37	100

1) Duty cycle current rms value = 1.15 x I_e → motor protection

2) Duty cycle limit for motor starter. The motor should be protected against overload here by means of a thermistor.

Switching cycles/hour for 3RK1325-6LS71-AA.(1.5 A to 12 A)												
Mounting position	Vertical						Horizontal					
Rated current I_e	7 A		5.8 A		5 A		6 A		5 A		4.5 A	
Ambient temperature	40 °C		50 °C		55 °C		40 °C		50 °C		55 °C	
Motor protection	1)	2)	1)	2)	1)	2)	1)	2)	1)	2)	1)	2)
Class 5 (10a)												
On time =30 % (8 x I_e) / 0.3 s	200	630	200	670	200	740	200	700	200	700	200	700
On time =70 % (8 x I_e) / 0.3 s	120	280	120	290	120	330	120	320	120	320	120	320
On time =30 % (8 x I_e) / 0.6 s	100	320	100	330	100	370	100	350	100	350	100	350
On time =70 % (8 x I_e) / 0.6 s	60	140	60	140	60	160	60	160	60	160	60	160
Class 10												
On time =30 % (8 x I_e) / 0.6 s	100	320	100	330	100	370	100	350	100	350	100	350
On time =70 % (8 x I_e) / 0.6 s	60	140	60	140	60	160	60	160	60	160	60	160
On time =30 % (8 x I_e) / 1.2 s	50	160	50	170	50	190	50	170	50	170	50	170
On time =70 % (8 x I_e) / 1.2 s	30	70	30	70	30	80	30	80	30	80	30	80

1) Duty cycle current rms value = 1.15 x I_e → motor protection

2) Duty cycle limit for motor starter. The motor should be protected against overload here by means of a thermistor.

Switching cycles/hour for 3RK1325-6LS71-AA.(1.5 A to 12 A)													
Mounting position	Vertical						Horizontal						
Rated current I_e	9 A		9 A		9 A		9 A		9 A		9 A		
Ambient temperature	40 °C		50 °C		55 °C		40 °C		50 °C		55 °C		
Motor protection	1)	2)	1)	2)	1)	2)	1)	2)	1)	2)	1)	2)	
Class 5 (10a)													
On time =30 % (8 x I_e) / 0.35 s	170	330	170	240	170	200	170	280	170	200	170	170	
On time =70 % (8 x I_e) / 0.35 s	100	280	100	190	100	150	100	230	100	155	100	120	
On time =30 % (8 x I_e) / 0.7 s	85	170	85	120	85	100	85	140	85	105	85	85	
On time =70 % (8 x I_e) / 0.7 s	52	140	52	95	52	75	52	120	52	82	52	62	
Class 10													
On time =30 % (8 x I_e) / 0.75 s	85	160	85	115	85	95	80	130	80	95	80	80	
On time =70 % (8 x I_e) / 0.75 s	52	130	52	90	52	70	50	110	50	75	50	57	
On time =30 % (8 x I_e) / 1.5 s	40	80	40	59	40	48	40	67	40	48	40	40	
On time =70 % (8 x I_e) / 1.5 s	25	67	25	47	25	37	25	56	25	38	25	29	

1) Duty cycle current rms value = 1.15 x I_e → motor protection

2) Duty cycle limit for motor starter. The motor should be protected against overload here by means of a thermistor.

8.8 Electrical service life of contactor

Service life of main contacts (DSte / RSte) to 5.5 kW

The curves show the contact service life of contactors when switching ohmic and inductive three-phase loads (AC-1/AC-3) as a function of breaking current and rated operating voltage. The prerequisite for this are command devices that switch at random, i.e. not synchronously to the phase angle of the line.

The rated operating current I_e in accordance with utilization category AC-4 (breaking of 6 times the rated operating current) is determined for a contact service life of at least 200 000 operating cycles.

If a smaller contact service life is sufficient, the rated operating current I_e /AC-4 can be increased.

If **mixed operation** is available, i.e. if normal switching operation (breaking of rated operating current in accordance with utilization category AC-3) is mixed with occasional inching (breaking of the multiple rated operating current in accordance with utilization category AC-4), the service life of the contacts can be calculated approximately with the following formula:

$$X = \frac{A}{1 + \frac{C}{100} * \left(\frac{A}{B} - 1 \right)}$$

- X Contact service life for mixed operation in operating cycles
- A Contact service life for normal operation ($I_a = I_e$) in operating cycles
- B Contact service life for inching ($I_a = \text{multiple of } I_e$) in operating cycles
- C Proportion of inching operations in the total operations as a percentage

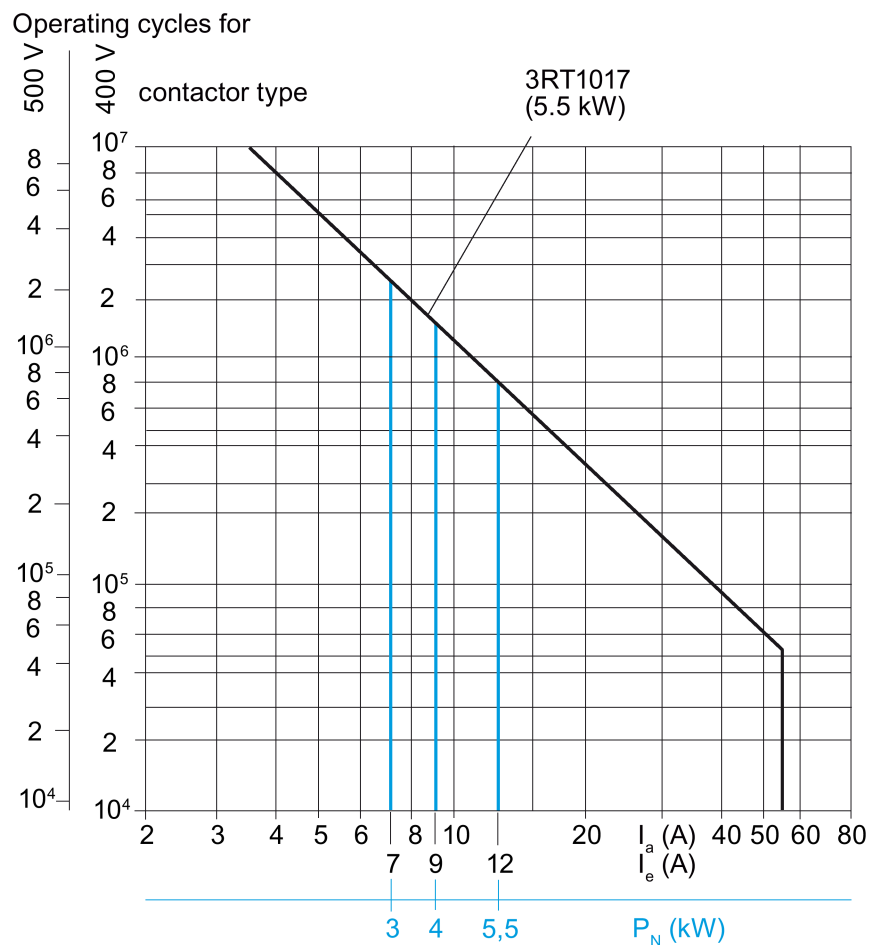

- P_N Rated power of three-phase motors at 400 V
- I_a Breaking current
- I_e Rated operating current

Figure 8-2 Service life of main contacts for contactor 3RT1017

8.9 Dimension drawing

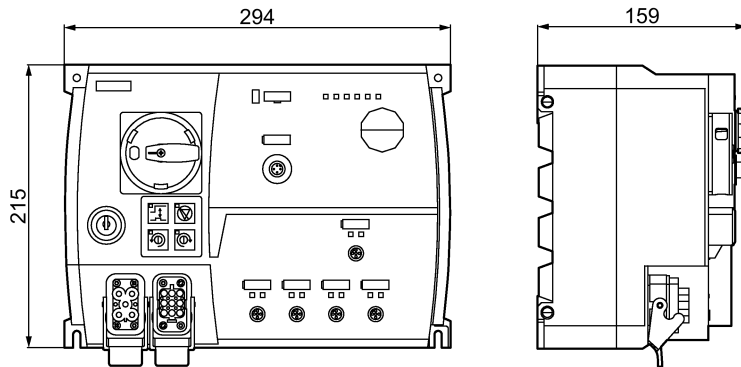

Figure 8-3 M200D AS-i motor starter without protection guard

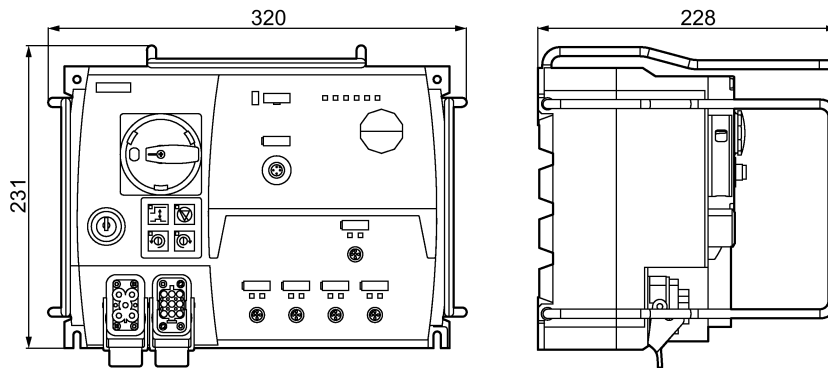

Figure 8-4 M200D AS-i motor starter with protection guard

Appendix

A.1 Acyclic data transfer via CTT2

As well as transferring the extended process image cyclically by means of CTT2 (Combined Transaction Type 2 (Page 123)), Slave 1 also transfers data set information to the motor starter, or receives it from the motor starter, acyclically.

The process of transferring CTT2 data from the CPU to AS-i master is dependent on the master.

The section that follows describes the process using the example of the DP/AS-i Link Advanced.

For more details, please refer to the manual for the DP/AS-i Link Advanced.

If you are **not** using a SIEMENS AS-i master, please observe the information in the documentation for the master you are using. **The way in which the data transfer process is structured differs according to the SIEMENS AS-i master in question.**

If you are working with SIEMENS AS-i masters and SIMATIC S7 controllers, FC ASI_3422 offers a user-friendly command interface.

Please note, however, that FC ASI_3422 does **NOT** work with third-party AS-i masters.

Calling block FC ASI_3422 enables you to both transfer commands and accept response data. For this purpose, FC ASI_3422 administers the calls Write_data_set and Read_data_set autonomously.

When the command interface is called using command 44_H (byte 0; see the table Job data in the send buffer (Page 161)), a byte string can be used to send a CTT2 request to the AS-i master. This forwards the string bytes to the AS-i slave address specified in the send buffer (byte 1; see the table titled "Job data in the send buffer").

The AS-i master determines the number of string bytes to be sent to the AS-i slave (and, therefore, to the motor starter M200D; the number depends on the data set to be transferred) on the basis of byte 2 of the send buffer (number of string bytes).

The addressed AS-i slave responds to the CTT2 request with a CTT2 response. The AS-i master communicates this response as a byte string in the receive buffer.

The structure of the CTT2 request or CTT2 response (code, index, etc.) begins with string byte 1 in each case and is not dependent on the master. Details of this are outlined below.

The M200D AS-i Standard supports the following data sets:

Write	Device parameter	DS 203	28 bytes
	Command data set	DS 93	10 bytes
Read	Device diagnostics	DS 200	9 bytes
	Measured values	DS 201	7 bytes
	Statistical data	DS 202	21 bytes
	Device parameters	DS 203	28 bytes

The extended process image with the addressed AS-i slave is not transferred while string transfers to the AS-i are taking place.

Depending on the type of protocol, the process of transferring a data set to a slave may take up to 5 s.

A.1.1 Structure of the transfer protocol

CTT2 commands and feedback (request/response)

The M200D Standard supports the following commands and feedback for transferring data sets:

Code	Meaning according to AS-i spec. V3.0	Followed by
144 _{dec} (90 _H)	Read response not ok	Standard error code
18 _{dec} (12 _H)	Read request	Index, length
82 _{dec} (52 _H)	Read response ok	Data
146 _{dec} (92 _H)	Read response not ok	Standard error code, data set error code
19 _{dec} (13 _H)	Write request	Index, length, data
83 _{dec} (53 _H)	Write response ok	—
147 _{dec} (93 _H)	Write response not ok	Standard error code, data set error code

This CTT2 data structure is defined in the AS-i specification V3.0 and is, therefore, the same for all AS-i masters. The various manufacturers of AS-i masters use different mechanisms for transferring this CTT2 data to the master, however (command interface or comparable methods). Please refer to the user documentation for the AS-i master for detailed information on this.

Therefore, it is up to the user to combine the master-dependent component of the protocol and the non-master-dependent CTT2 data in order to obtain a transfer protocol that is complete.

A.1.2 Writing CTT2 data sets

Job data in the send buffer

Byte	Master-dependent content	Meaning according to AS-i spec. V3.0 (non-master-dependent)	Value for DS 93 "Commands"	Value for DS 203 "Parameters"	Meaning
p+0	Command number:	—	68 _{dec} (44 _H)	68 _{dec} (44 _H)	Command for "Write CTT2 request"
p+1	Slave address	—	xx	xx	Bits 0 to 4: Slave address Bit 5: 0 = A addr., 1 = B addr. (= add to A address 32 as offset)
p+2	Number of string bytes	—	13 _{dec} (0D _H)	31 _{dec} (1F _H)	= Number of subsequent bytes (DS length + 3)
p+3	String byte 1 =	CTT2: Code	19 _{dec} (13 _H)	19 _{dec} (13 _H)	= CTT2 request for "Write DS"
p+4	String byte 2 =	CTT2: Index	93 _{dec} (5D _H)	203 _{dec} (CB _H)	= DS number
p+5	String byte 3 =	CTT2: Length	10 _{dec} (0A _H)	28 _{dec} (1C _H)	= DS length
p+6	String byte 4 =	CTT2: Data 1	33 _{dec} (21 _H)	33 _{dec} (21 _H)	DS byte 0 = Header (coordination)
p+7	String byte 5 =	CTT2: Data 2	0	0	DS byte 1 = Header (reserved)
p+8	String byte 6 =	CTT2: Data 3	0	0	DS byte 2 = Header (reserved)
p+9	String byte 7 =	CTT2: Data 4	0	0	DS byte 3 = Header (reserved)
p+10	String byte 8 =	CTT2: Data 5	xx	xx	DS byte 4 = Technology data
p+11	String byte 9 =	CTT2: Data 6	xx	xx	DS byte 5 = Technology data
...
p+33	String byte 31 =	CTT2: Data 28	—	xx	DS byte 27 = Technology data

Response data in the receive buffer

Byte	Master-dependent content	Error-free transfer	Transfer with error (CTT2 error)	Transfer with error (CTT2_command not supported)	Transfer with error (DS error)	Meaning
q+0	Number of string bytes	01 _H	02 _H	02 _H	04 _H	= Number of subsequent bytes
q+1	String byte 1	83 _{dec} (53 _H)	147 _{dec} (93 _H)	144 _{dec} (90 _H)	147 _{dec} (93 _H)	= CTT2 response code
q+2	String byte 2	—	xx	03 _{dec} (03 _H)	00	= Standard error
q+3	String byte 3	—	—	—	80 _H	= DS error_H
q+4	String byte 4	—	—	—	xx	= DS error_L

p = Start address of the send buffer in the DP master

q = Start address of the response buffer in the DP master

DS = Data set

xx = Variable content

For variable content, see Error codes with negative data set acknowledgment (Page 166)

For technology data, see DS description (Page 171)

The figure below illustrates how a data set is written using the example of data set DS 203, "Parameters":

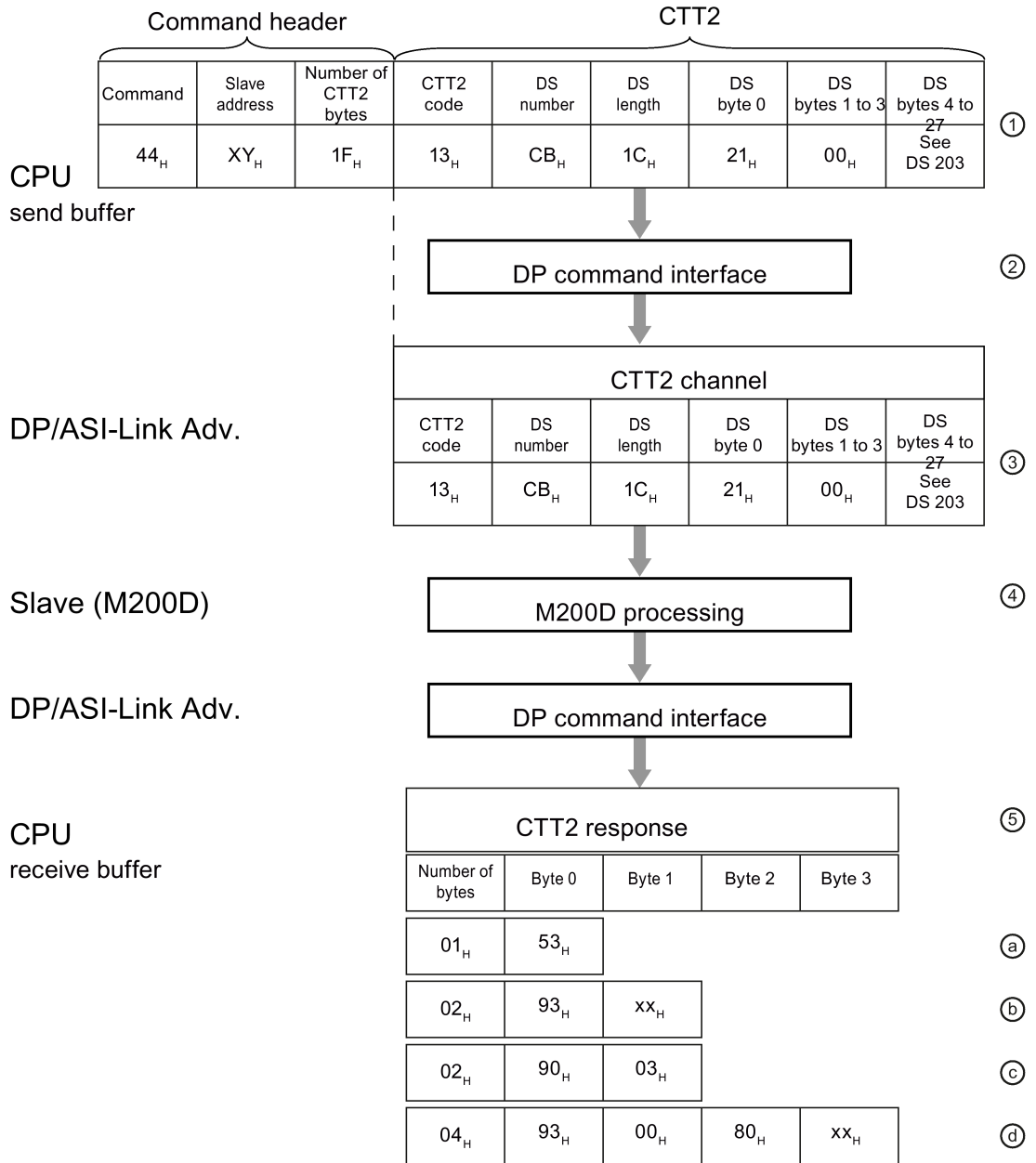

Figure A-1 Writing CTT2 data sets

① The "Write a data set" command is provided in the send buffer. The first three bytes (command header) contain the command code (44_H), slave address, and number of CTT2 bytes. The CTT2 data set follows this.

②	The CTT2 data set begins with the CTT2 command code (13 _H), the data set number (CB _H = 203 _{dec}), and the data set length, followed by the data set bytes DS byte 0 to DS byte 27. The DP command interface for the AS-i master (DP/AS-i Link Advanced) accepts the data set bytes and forwards them to the addressed slave.
③	The slave processes the command and sends the response to the AS-i master.
④	The AS-i master accepts the response and forwards it to the receive buffer of the CPU via the DP command interface.
⑤	The response is decoded in the receive buffer of the CPU and the program is executed accordingly. The following responses are possible:
a	53 _H : Error-free transfer
b	93 _H : Transfer with error (CTT2 error)
c	90 _H : Transfer with error (CTT2_command not supported)
d	93 _H : Transfer with error (data set error; see M200D data set error code (Page 166))

A.1.3 Reading CTT2 data sets

Job data in the send buffer

Byte	Master-dependent content	Meaning according to AS-i spec. V3.0 (non-master-dependent)	Value for DS 200 "Diagnostics"	Value for DS 201 "Measured values"	Value for DS 202 "Statistical data"	Value for DS 203 "Parameters"	Meaning
p+0	Command number:	—	68 _{dec} (44 _H)	68 _{dec} (44 _H)	68 _{dec} (44 _H)	68 _{dec} (44 _H)	CTT2 request_write
p+1	Slave address	—	xx	xx	xx	xx	Bits 0 to 4: Slave address Bit 5: 0 → A addr. 1 → B addr.
p+2	Number of string bytes	—	3 _{dec} (03 _H)	3 _{dec} (03 _H)	3 _{dec} (03 _H)	3 _{dec} (03 _H)	Number of subsequent bytes
p+3	String byte 1 =	CTT2: Code	18 _{dec} (12 _H)	18 _{dec} (12 _H)	18 _{dec} (12 _H)	18 _{dec} (12 _H)	= CTT2 command
p+4	String byte 2 =	CTT2: Index	200 _{dec} (C8 _H)	201 _{dec} (C9 _H)	202 _{dec} (CA _H)	203 _{dec} (CB _H)	= DS number
p+5	String byte 3 =	CTT2: Length	9 _{dec} (09 _H)	7 _{dec} (07 _H)	21 _{dec} (15 _H)	28 _{dec} (1C _H)	= DS length

Response data in the receive buffer (error-free DS transfer)

Byte	Master-dependent content	Value for DS 200 "Diagnostics"	Value for DS 201 "Measured values"	Value for DS 202 "Statistical data"	Value for DS 203 "Parameters"	Meaning
q+0	Number of string bytes	10 _{dec} (0A _H)	8 _{dec} (08 _H)	22 _{dec} (16 _H)	29 _{dec} (1D _H)	= DS length + 1
q+1	String byte 1	82 _{dec} (52 _H)	82 _{dec} (52 _H)	82 _{dec} (52 _H)	82 _{dec} (52 _H)	CTT2 code
q+2	String byte 2	xx	xx	xx	xx	DS byte 0
q+3	String byte 3	xx	xx	xx	xx	DS byte 1
q+4	String byte 4	xx	xx	xx	xx	DS byte 2
...		xx	xx	xx	xx	
q+7	String byte 8	xx	xx	xx	xx	DS byte 6
...		xx	—	xx	xx	
q+9	String byte 10	xx	—	xx	xx	DS byte 8
...		—	—	xx	xx	
q+21	String byte 22	—	—	xx	xx	DS byte 20
...		—	—	—	xx	
q+28	String byte 29	—	—	—	xx	DS byte 27

p = Start address of the send buffer in the DP master

q = Start address of the response buffer in the DP master

DS = Data set

xx = Variable content

Response data in the receive buffer (transfer with error)

Byte	Master-dependent content	Transfer with error (CTT2 error)	Transfer with error (CTT2_command not supported)	Transfer with error (DS error)	Meaning
q+0	Number of string bytes	02 _{dec}	02 _{dec}	04 _{dec}	= Number of subsequent bytes
q+1	String byte 1	146 _{dec} (92 _H)	144 _{dec} (90 _H)	146 _{dec} (92 _H)	= CTT2 response code
q+2	String byte 2	xx	03 _{dec} (03 _H)	00	= Standard error
q+3	String byte 3	—	—	xx	= DS error_H
q+4	String byte 4	—	—	xx	= DS error_L

q = Start address of the response buffer in the DP master

DS = Data set

xx = Variable content

The figure below illustrates how a data set is read using the example of data set DS 200, "Diagnostics":

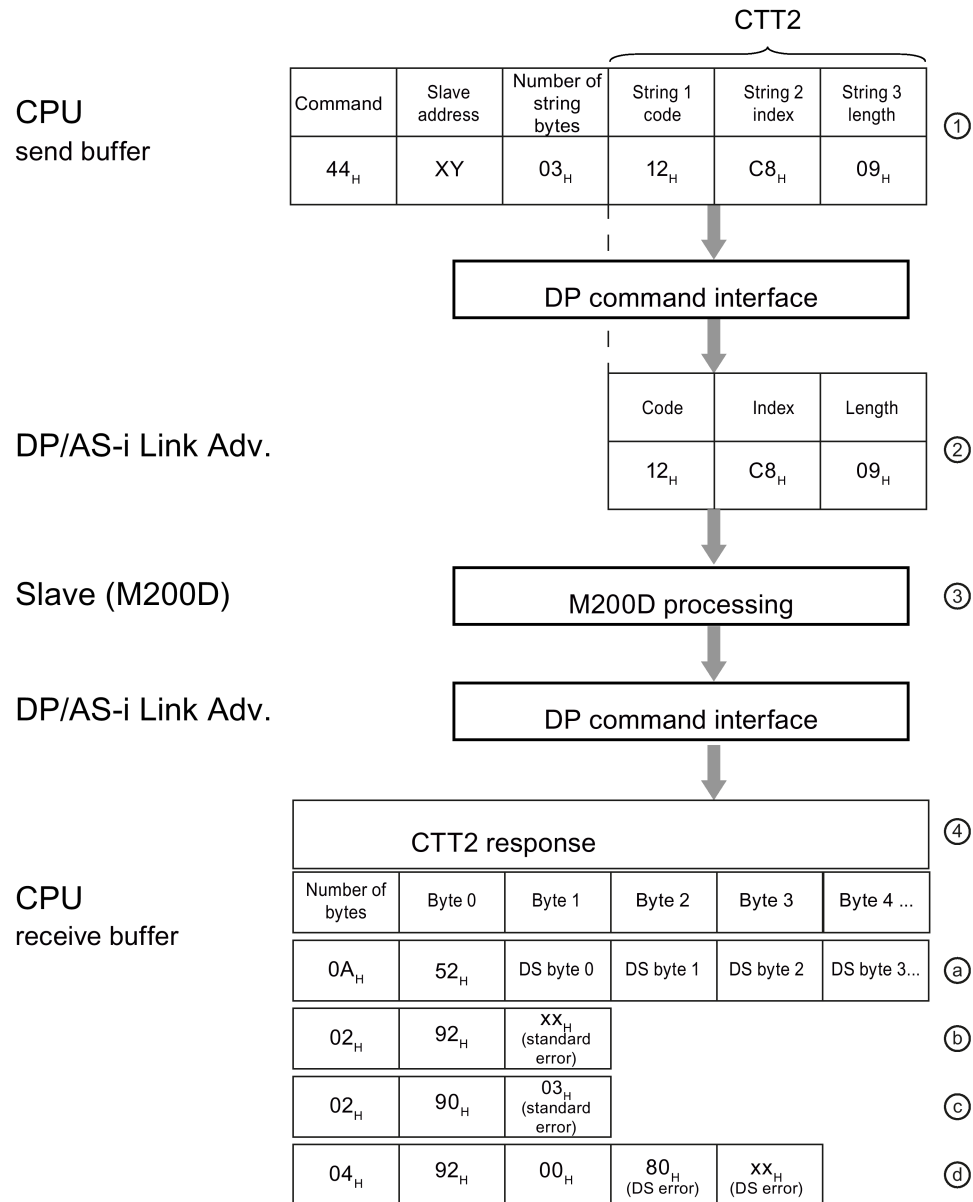

Figure A-2 Reading CTT2 data sets

①	The CPU sends the CTT2 data request (using command 44: CTT2 request_write) from the send buffer to the AS-i master via the command interface. The header contains the slave address and the number of string bytes.
②	The AS-i master accepts the request and forwards it to the addressed slave (code 18: acyclic vendor specific read service request).

A.1 Acyclic data transfer via CTT2

③	Within one second, the slave processes the job and sends the response to the AS-i master.
④	The AS-i master forwards the CTT2 data to the receive buffer of the CPU. The following responses are possible:
a	52 _H : Error-free transfer
b	92 _H : Transfer with error (CTT2 error)
c	90 _H : Transfer with error (CTT2_command not supported)
d	92 _H : Transfer with error (data set error)

A.1.4 Error codes with negative data set acknowledgment

If a data set is transferred with an error or rejected by the M200D motor starter, the negative acknowledgment is accompanied by an "error code" explaining the reason for the negative acknowledgment.

Standard error code (CTT2 transfer error)

CTT2 error	Meaning
0	No error
1	Impermissible index
2	Impermissible length
3	Request not implemented
4	Busy (request was not fully executed within the time frame; request again later)
5	Last acyclic request not yet acknowledged

M200D data set error code

DS error		Error message	Possible causes	Remedial measures
_H	_L			
_Highbyte	_Lowbyte			
00 _H	00 _H	No error (bytes not transferred)		
From communication interface (= application)				
80 _H	A2 _H	Protocol error	<ul style="list-style-type: none"> • Protocol error, layer 2 (fieldbus) • Protocol error, user interface (device interface) • Incorrect coordination 	<ul style="list-style-type: none"> • With "writing" data sets, check coordination (1st byte) and send again. • With "reading" data sets, simply repeat the process.

DS error		Error message	Possible causes	Remedial measures
_H	_L			
_Highbyte	_Lowbyte			
From technology function (= access)				
80 _H	B0 _H	Unknown data set number	<ul style="list-style-type: none"> DS no. not supported by device 	<ul style="list-style-type: none"> None, since the device does not recognize this data set no.
80 _H	B1 _H	Incorrect data set length when writing	<ul style="list-style-type: none"> DS length ≠ specified DS length 	<ul style="list-style-type: none"> Change DS length to match specified length and send DS again
80 _H	B6 _H	Device has rejected data transfer	<ul style="list-style-type: none"> Due to incorrect mode Data set is read-only Parameter change not permissible in current device/system operating mode 	Check whether <ul style="list-style-type: none"> The correct mode is set on the device for the data sent A data set that can only be read is to be written A parameter has been changed even though it may only be changed in a particular operating mode
80 _H	B8 _H	Invalid parameter	<ul style="list-style-type: none"> Incorrect/invalid parameter values were received 	<ul style="list-style-type: none"> Change the parameter value to a valid one and resend.
From device (= resource)				
80 _H	C2 _H	Temporary lack of resources in the device	<ul style="list-style-type: none"> No free receive buffer The data set is currently being updated The data set job is currently being processed on a different interface 	<ul style="list-style-type: none"> Attempt communication again!

A.2 Data formats and data sets

A.2.1 Data formats

Properties

The motor starter calculates a host of operating, diagnostic, and statistical data. Control data is transferred to the motor starter.

Control data

Data that is transferred to the motor starter, e.g. switching command motor CCW, trip reset, etc.

Data format: Bit

Messages

Data that is transferred from the motor starter and that indicates the current operating status, e.g. motor CCW, etc.

Data format: Bit

Diagnostics

Data that is transferred from the motor starter and that indicates the current operating status, e.g. fault overload, etc.

Data format: Bit

Current values

Current values are encoded in different formats: 6-bit current format, 8-bit current format, and 9-bit current format:

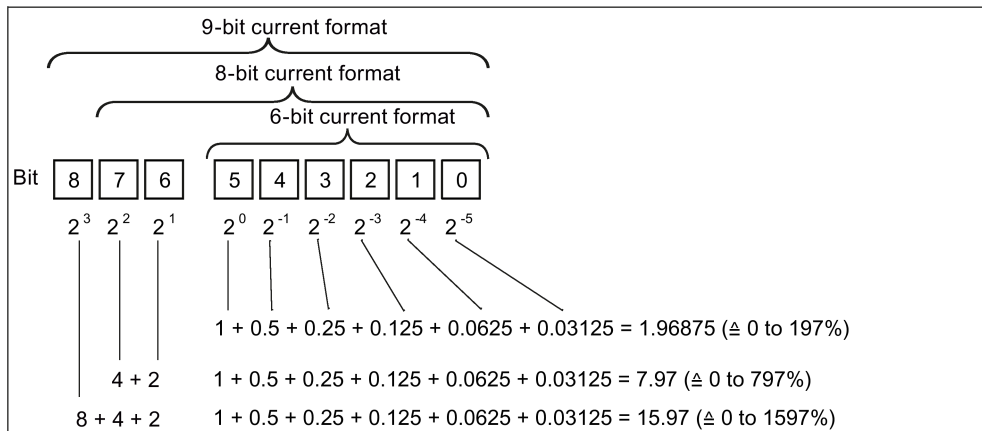

Current values are

- Motor current I_{max} (6-bit current format)
- Phase currents $I_{L1 max}$, $I_{L2 max}$, $I_{L3 max}$ (8-bit current format)
- Last tripping current (9-bit current format)
- Maximum tripping current (9-bit current format)

Statistical data on device service life

- Operating hours
The motor starter records 2 operating hours values:
 - The operating hours of the motor.
This indicates how long the motor was switched on.
 - The operating hours of the device (motor starter).
This indicates how long the PWR power supply of the motor starter was switched on.

Both operating hours values are recorded in data set 203 – Statistics.

The operating hours are recorded in the range 0 to 16,777,215 minutes in 1-minute increments.

- Number of overload trips
The motor starter counts the number of overload trips in the range 0 to 65,535.
- Number of starts motor CW/CCW
The motor starter counts the number of starts in the range 0 to 16,777,215.
Example: The value is incremented by 1 when the current is flowing in the main circuit after the "Motor ON" command has been issued.
- Motor current I_{max} .
The motor starter measures the current in all 3 phases and displays the current of the phase under the greatest load as a percentage [%] of the current setting I_e .
Data format: 1 byte, 8-bit current format
Example: Current setting $I_e = 10$ A
of the indicated motor current 110%
then corresponds to $10 \text{ A} \times 1.1 = 11 \text{ A}$
All 3 phase currents are available in data set 201
- Last tripping current
The motor starter measures the current in all 3 phases and displays the current that is flowing in the phase under the greatest load when the trip occurs as a percentage [%] of the current setting I_e and in amperes [A]
Data format: 2 bytes, 9-bit current format
Example: Current setting $I_e = 10$ A
of the indicated motor current 455% then corresponds to $10 \text{ A} \times 4.55 = 45.5 \text{ A}$
The value can be read out in data set 202

Statistical data maximum pointers

Maximum pointers are used for preventive diagnostics:

The maximum measured value is stored in the device.

The higher-level PLC can fetch the measured value at any time.

The higher-level PLC can delete the measured value at any time.

The following data is available in the form of a maximum pointer:

- Number of motor overload trips
- Operating hours motor current = 18 to 49.9% of I_e
- Operating hours motor current = 50 to 89.9% of I_e
- Operating hours motor current = 90 to 119.9% of I_e
- Operating hours motor current = 120 to 1,000% of I_e
- Maximum tripping current $I_{A \max}$ (%)
- Maximum tripping current $I_{A \max}$ (rms)
- Phase current $I_{L1 \max}$ to $I_{L3 \max}$. Maximum phase current as a percentage [%] of the current setting I_e and in amperes [A]
Data format: 1 byte each, 8-bit current format.
The measured maximum phase current in each case is stored per phase.
- Maximum heat sink temperature (with sDSSSte/sRSSSte 12 A)

The measured values can only be read out using Motor Starter ES.

A.2.2 Data sets

Byte arrangements

When data longer than one byte is stored, the bytes are arranged as follows ("big endian"):

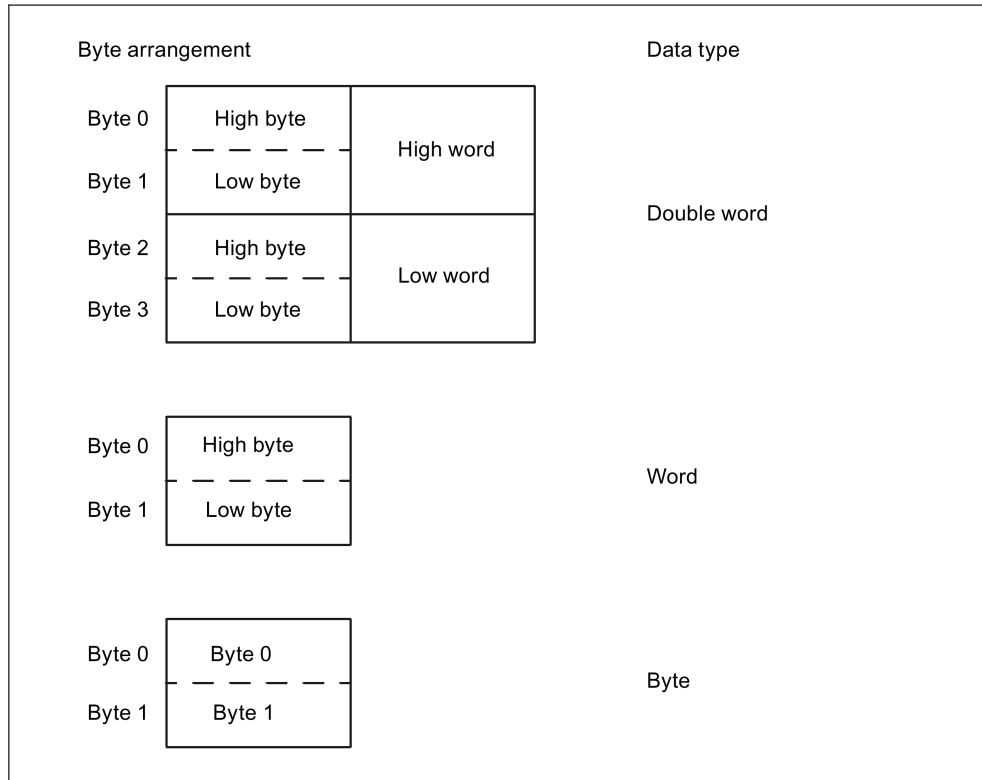

A.2.2.1 Writing data set 93 (commands)

Byte.Bit	Code	Meaning
0	0x21	
1	0x00	
2	0x00	
3	0x00	
4	(1 byte)	
	0x00	Do not process any commands
	0x01	Process command_1
	0x02	Process command_1 and 2
	0x03	Process command_1, 2, and 3
	0x04	Process command_1, 2, 3, and 4
	0x05	Process command_1, 2, 3, 4, and 5
5	See below	Command_1
6		Command_2
7		Command_3
8		Command_4
9		Command_5

Data is transferred to the device using the "Write data set" function.

The following commands are used:

	Code	Meaning
Object name	Command	
Object length	1 byte	
Value range	0 to 255	
Meaning	0	No function
	1	Trip reset
	2	Emergency start ON
	3	Emergency start OFF
	6	Factory settings
	7	Delete maximum pointer
	9	Restart
	10	Parameters disabled CPU/master ON
	11	Parameters disabled CPU/master OFF
	13	Delete logbook - Triggering operations
	14	Delete logbook - Events
	15	Cold run ON
16	Cold run OFF	

A.2.2.2 Reading data set 200 (device diagnostics)

Byte.Bit	Code	Meaning	Relevant for
User data (= technology data)			
Switch/Control			
0.0	Bit (1 = active)	Ready (automatic)	x
0.1		Motor CW	x
0.2		Motor CCW	.RS... only
0.3		Switching element overload	x
0.4		Switching element defective	x
0.5		Emergency start active	x
0.6		Group fault	x
0.7		Group warning	x
1.0	Bit (1 = active)	No switching element supply voltage	x
1.1		No supply voltage	..SS.. only
1.2		Lock-out time active	.RS... only
1.3		Starting active	..SS.. only
1.4		Run-down active	..SS.. only
1.5		Brake output active	with BO only ¹⁾
1.6		Ready for motor ON	x
1.7		Self-test error	x
Protection function (motor, cable, short-circuit)			
2.0	Bit (1 = active)	Temperature sensor overload	x
2.1		Temperature sensor wire break	x
2.2		Temperature sensor short-circuit	x
2.3		Thermal motor model overload	x
2.4		Overload tripping	x
2.5		Idle time active	x
2.6		Cooling time active	x
2.7		Temperature sensor deactivated	x
3.0	Bit (1 = active)	Thermal motor model deactivated	x
3.1		Prewarning limit - motor heating overshoot	x
3.2		Circuit breaker tripped	x
3.3		Current limiting active	..SS.. only
3.4		Cold start active	x
3.5		Cold start tripping	x
3.6		Connector monitoring deactivated	x
3.7		Connector removed on line side	x

Byte.Bit	Code	Meaning	Relevant for
4.0	Bit (1 = active)	Asymmetry detected	x
4.1		Asymmetry tripping	x
4.2		I _e limit value overshoot	x
4.3		I _e limit value undershoot	x
4.4		I _e limit value tripping	x
4.5		Residual current detected	x
4.6		Residual current tripping	x
4.7		Tripping due to motor blocking	x
5.0	Bit (1 = active)	Input 1	x
5.1		Input 2	x
5.2		Input 3	x
5.3		Input 4	x
5.4		Input tripping	x
5.5		Input tripping limit position CW rotation	x
5.6		Input warning	x
5.7		Input tripping limit position CCW rotation	x
6.0	Bit (1 = active)	Input controls	x
6.1		Output 1 active	x
6.2		Output 1 overloaded	x
6.3		Quick stop active	x
6.4		Sensor supply overload	x
6.5		Trip reset executed	x
6.6		Trip reset not possible	x
6.7		Electronics supply voltage too low	x
Communication			
7.0	Bit (1 = active)	Bus error	x
7.1		CPU/Master STOP	x
7.2		Automatic mode	x
7.3		Manual mode local (local control)	x
7.4		Manual local - HMI controls	x
7.5		Manual local - input controls	x
7.6		Connection abort in manual mode	x
7.7		Process image error	x

Byte.Bit	Code	Meaning	Relevant for
Parameter			
8.0	Bit (1 = active)	Parameter assignment active	x
8.1		Invalid parameter value	x
8.2		Parameters cannot be changed in ON state	x
8.3		Parameters disabled CPU/master active	x
8.4		No external startup parameters received	x
8.5		Factory settings restored	x
8.6		Free	
8.7		free	

1) BO: Brake output

A.2.2.3 Reading data set 201 (measured values)

Byte.Bit	Code	Meaning	Relevant for
User data (= technology data)			
Measured values (= volatile!)			
0	Unsigned 8	Phase current IL1 (%)	All
1	Unsigned 8	Phase current IL2 (%)	All
2	Unsigned 8	Phase current IL3 (%)	All
3.0...6 3.7	1 byte	Motor heating (%) Asymmetry	All
4...5	Unsigned 16	Remaining motor cooling time	All
6	Unsigned 8	Asymmetry	All

A.2.2.4 Reading data set 202 (statistical data)

Byte.Bit	Code	Meaning	Relevant for
User data (= technology data)			
0 ... 1	Unsigned 16	Last tripping current I _A (%)	All
2 ... 5	Unsigned 32	Operating hours device	All
6 ... 9	Unsigned 32	Number of starts motor CW	All
10 ... 13	Unsigned 32	Number of starts motor CCW	.RS...
14 ... 15	Unsigned 16	Number of motor overload trips	All
16 ... 19	Unsigned 32	Operating hours motor	All
20	Unsigned 8	Motor current I _{max} (%)	All

A.2.2.5 Reading/writing data set 203 (device parameters)

DS 203 (device parameters)

We recommend initially reading out data set 203 from the motor starter with the current parameters, changing the corresponding parameters, and then rewriting these to the motor starter.

Please be aware that the coordination (byte 0) is to be set to 0x21 prior to writing the data set.

Byte.Bit	Parameter	Value range/[code]	Increment	Default setting	Relevant for
Header					
0	Coordination	—	—	0x21 (33dec)	—
1	Reserved	—	—	0	—
2	Slot no.	—	—	0	—
3	Subslot no.	—	—	0	—
Data (= technology data)					
4 to 5	Rated operational current I_e	0.15 to 2.0 A/ 1.5 to 12 A	10 mA	2 A/9 A/12 A (MS) 0.15 A/1.5 A (ES tool)	All
6.0 to 3	Trip class	[0] CLASS 10 [1] CLASS 20 [3] CLASS 5 (10a) [4] CLASS 15 [15] CLASS OFF	—	[0] CLASS 10	All
6.4 to 6	Temperature sensor	[0] Deactivated [1] Thermoclick [2] PTC type A	—	[0] Deactivated	All
6.7	Free	—	—	—	—
7.0 to 1	Response to overload - thermal motor model	[0] Trip without restart [1] Trip with restart [2] Warning	—	[0] Trip without restart	All
7.2 to 3	Response to temperature sensor overload	[0] Trip without restart [1] Trip with restart [2] Warning	—	[0] Trip without restart	All
7.4 to 5	Response to switching element supply voltage cut-off	[0] Group fault [1] Group fault only with ON command [2] Group warning	—	[0] Group fault	All
7.6	Response to current limit violation	[0] Warning [1] Trip	—	[0] Warning	All
7.7	Response to residual current detection	[0] Warning [1] Trip	—	[0] Trip	All
8.0 to 1	Response to circuit breaker OFF	[0] Group fault [1] Group fault only with ON command [2] Group warning	—	[0] Group fault	All

Byte.Bit	Parameter	Value range/[code]	Increment	Default setting	Relevant for
8.2	Response to asymmetry	[0] Warning [1] Trip	—	[1] Trip	All
8.3 to 6	Connector monitoring	[0]: Deactivated [1]: Line side	—	[0] Deactivated	All
8.7	Free	—	—	—	—
9.0 to 3	Response when connector removed	[0] Group fault [1] Group fault only with ON command [2] Group warning	—	[0] Group fault	All
9.4	Group diagnostics	[0] Block [1] Enable		[0] Blocked	All
9.5	Response to CPU/Master STOP	[0] Switch substitute value [1] Retain last value	—	[0] Switch substitute value	All
9.6 to 7	Free	—	—	—	—
10	Lower current limit	[6 to 32] 18.75 to 100% [0] Deactivated	3.125%	[6] 18.75%	All
11	Upper current limit	[16 to 128] 50% to 150, 400% [0] Deactivated	3.125%	[36] 112.5%	All
12.0	Input 1 level	[0] Normally closed [1] Normally open	—	[1] Normally open	All
12.1	Input 2 level	[0] Normally closed [1] Normally open	—	[1] Normally open	All
12.2	Input 3 level	[0] Normally closed [1] Normally open	—	[1] Normally open	All
123	Input 4 level	[0] Normally closed [1] Normally open	—	[1] Normally open	All
12.4	Input 1 signal	[0] Non-retentive [1] Retentive	—	[0] Non-retentive	All
12.5	Input 2 signal	[0] Non-retentive [1] Retentive	—	[0] Non-retentive	All
12.6	Input 3 signal	[0] Non-retentive [1] Retentive	—	[0] Non-retentive	All
12.7	Input 4 signal	[0] Non-retentive [1] Retentive	—	[0] Non-retentive	All
13.0 to 3	Input 1 action	[0] No action	—	[0] No action	All
13.4 to 7	Input 2 action	[1] Trip without restart [2] Trip with restart	—	[0] No action	All
14.0 to 3	Input 3 action	[3] Trip end position CW	—	[0] No action	All
14.4 to 7	Input 4 action	[4] Trip end position CCW [5] Group warning [6] Manual mode local [7] Emergency start [8] Motor CW [9] Motor CCW (on RS only) [11] Quick stop [12] Trip reset [13] Cold start	—	[0] No action	All

Byte.Bit	Parameter	Value range/[code]	Increment	Default setting	Relevant for
15.0 to 1	Output 1 level	[0]: Non-inverted [1]: Inverted [2 to 3]: Reserved	—	[0] Non-inverted	All
15.2 to 5	Output 1 signal	[0]: Permanent [1]: Flashing [6 to 15]: Reserved	—	[0] Permanent	All
15.6 to 7	Free	—	—	—	—
16	Output 1 action	[00]: No action [01]: Control source PIO DO2 Slave 1 (output 1) [06]: Control source input 1 [07]: Control source input 2 [08]: Control source input 3 [09]: Control source input 4 [10]: Run-up [11]: Operation/shunting [12]: Coasting down [13]: On time motor (RUN) [14]: Control command motor (ON) [17]: Brake output [18]: Device ON (PWR-AUX) [30]: Group prewarning [31]: Group warning [32]: Group fault [33]: Bus error [34]: Device error [38]: Ready for motor ON	—	[1] Output 1 (PIO DO2 Slave 1)	All
17	Starting time	0 to 30 s [0] Minimum ramp (100 ms)	0.25 s	[20] 5 s	s.SS..
18	Run-down time	0 to 30 s [0] Function deactivated	0.25 s	0 s	s.SS..
19	Starting voltage	[4 to 20] 20 to 100%	5%	[8] 40%	s.SS..
20	Stopping voltage	[4 to 18] 20 to 90%	5%	[8] 40%	s.SS..
21	Current limit value	125 to 600% For $I_e \geq 9 \text{ A} \rightarrow 125\% \text{ to } 50\%$	3.125%	[192] 600%	s.SS..
22.0 to 3	Startup mode	[0] Direct [1] Voltage ramp [4] Current limit [5] Voltage ramp + current limit	—	[0] Direct	s.SS..
22.4 to 7	Run-down type	[0] Run-down without load [1] Voltage ramp	—	[0] Run-down without load	s.SS..
23	Motor heating prewarning limit	0 to 95% [0] = Deactivated	5%	[0] Deactivated	All
24 to 25	Release delay time of brake on startup	- 2.5 to 2.5 s	0.01 s	0 ms	BO
26 to 27	Brake holding time on stopping	0 to 25 s	0.01 s	0 ms	BO

A.3 Order numbers

A.3.1 M200D AS-i order numbers

Order number structure (MLFB structure)

Position												Meaning
1 to 7	—	8	9	10	11	12	—	13	14	15	16	
3RK1325	—	6	↓	S	↓	1	—	↓	A	A	↓	M200D AS-i Standard motor starter
			K		↓			↓			↓	0.15 - 2.0 A
			L		↓			↓			↓	1.5 to 12.0 A
					4			↓			↓	Electromechanical
					7			↓			↓	Electronic
								0			↓	Direct starter without HMI ¹⁾
								1			↓	Reversing starter without HMI ¹⁾
								2			↓	Direct starter with HMI ¹⁾
								3			↓	Reversing starter with HMI ¹⁾
											0	Without brake output
											3	Brake output 400 V / 230 V AC
											5	Brake output 180 V DC

¹⁾ HMI: Integrated manual local control

Ordering examples

You can combine the key numbers/letters to create the MLFB of the required motor starter:

Position												Meaning
1 to 7	—	8	9	10	11	12	—	13	14	15	16	
3RK1325	—	6	K	S	4	1	—	2	A	A	5	Direct starter (Standard) with HMI, 0.15 to 2.0 A, electromechanical, with 180 V DC brake output

A.3.2 M200D AS-i Standard motor starters

Type Switching	Current range	Brake	Manual operation	Order number
Direct starter electromechanical DSte	0.15 to 2.0 A	-	-	3RK1325-6KS41-0AA0
		400/230 V AC	-	3RK1325-6KS41-0AA3
		180 V DC	-	3RK1325-6KS41-0AA5
		-	With HMI	3RK1325-6KS41-2AA0
		400/230 V AC	With HMI	3RK1325-6KS41-2AA3
		180 V DC	With HMI	3RK1325-6KS41-2AA5
	1.5 to 12.0 A	-	-	3RK1325-6LS41-0AA0
		400/230 V AC	-	3RK1325-6LS41-0AA3
		180 V DC	-	3RK1325-6LS41-0AA5
		-	With HMI	3RK1325-6LS41-2AA0
		400/230 V AC	With HMI	3RK1325-6LS41-2AA3
		180 V DC	With HMI	3RK1325-6LS41-2AA5
Reversing starter electromechanical RSte	0.15 to 2.0 A	-	-	3RK1325-6KS41-1AA0
		400/230 V AC	-	3RK1325-6KS41-1AA3
		180 V DC	-	3RK1325-6KS41-1AA5
		-	With HMI	3RK1325-6KS41-3AA0
		400/230 V AC	With HMI	3RK1325-6KS41-3AA3
		180 V DC	With HMI	3RK1325-6KS41-3AA5
	1.5 to 12.0 A	-	-	3RK1325-6LS41-1AA0
		400/230 V AC	-	3RK1325-6LS41-1AA3
		180 V DC	-	3RK1325-6LS41-1AA5
		-	With HMI	3RK1325-6LS41-3AA0
		400/230 V AC	With HMI	3RK1325-6LS41-3AA3
		180 V DC	With HMI	3RK1325-6LS41-3AA5
Direct soft starter electronic sDSSSte	0.15 to 2.0 A	-	-	3RK1325-6KS71-0AA0
		400/230 V AC	-	3RK1325-6KS71-0AA3
		180 V DC	-	3RK1325-6KS71-0AA5
		-	With HMI	3RK1325-6KS71-2AA0
		400/230 V AC	With HMI	3RK1325-6KS71-2AA3
		180 V DC	With HMI	3RK1325-6KS71-2AA5
	1.5 to 12.0 A	-	-	3RK1325-6LS71-0AA0
		400/230 V AC	-	3RK1325-6LS71-0AA3
		180 V DC	-	3RK1325-6LS71-0AA5
		-	With HMI	3RK1325-6LS71-2AA0
		400/230 V AC	With HMI	3RK1325-6LS71-2AA3
		180 V DC	With HMI	3RK1325-6LS71-2AA5

Type Switching	Current range	Brake	Manual operation	Order number
Reversing soft starter electronic sRSSte	0.15 to 2.0 A	-	-	3RK1325-6KS71-1AA0
		400/230 V AC	-	3RK1325-6KS71-1AA3
		180 V DC	-	3RK1325-6KS71-1AA5
		-	With HMI	3RK1325-6KS71-3AA0
		400/230 V AC	With HMI	3RK1325-6KS71-3AA3
		180 V DC	With HMI	3RK1325-6KS71-3AA5
	1.5 to 12.0 A	-	-	3RK1325-6LS71-1AA0
		400/230 V AC	-	3RK1325-6LS71-1AA3
		180 V DC	-	3RK1325-6LS71-1AA5
		-	With HMI	3RK1325-6LS71-3AA0
		400/230 V AC	With HMI	3RK1325-6LS71-3AA3
		180 V DC	With HMI	3RK1325-6LS71-3AA5

A.3.3 Spare parts/accessories

Power supply

Designation	Order no.
Power outlet connector, connector set for T distributor connection, consisting of coupling housing, straight outlet (with clip), pin insert for HAN Q4/2, incl. cable gland 5 contact pins 2.5 mm ² 5 contact pins 4 mm ² 5 contact pins 6 mm ²	3RK1911-2BS60 3RK1911-2BS20 3RK1911-2BS40
Power connector, connector set for connection to M200D motor starters, consisting of socket shell, angled outlet, socket insert for HAN Q4/2, incl. cable gland 5 socket contacts 2.5 mm ² , 2 socket contacts 0.5 mm ² 5 socket contacts 4 mm ² , 2 socket contacts 0.5 mm ² 5 socket contacts 6 mm ² , 2 socket contacts 0.5 mm ²	3RK1911-2BE50 3RK1911-2BE10 3RK1911-2BE30
Power supply cable, one end prefabricated, with "N" und jumper pin 11 und 12 for connector monitoring, with HAN Q4/2, angled; one end open; 5 x 4 mm ² Length 1.5 m Length 5.0 m	3RK1911-0DC13 3RK1911-0DC33

Motor cable

Designation	Order no.
Motor connector for connection to M200D motor starters, consisting of socket shell, angled outlet, pin insert for HAN Q8/0, incl. cable gland 8 contact pins 1.5 mm ² 6 contact pins 2.5 mm ²	3RK1902-0CE00 3RK1902-0CC00
Motor connector for connection to motor, consisting of socket shell, straight outlet, socket insert for HAN 10e, incl. neutral bridge, incl. cable gland 7 socket contacts 1.5 mm ² 7 socket contacts 2.5 mm ²	3RK1911-2BM21 3RK1911-2BM22
Motor cable, one end prefabricated, one end open, HAN Q8/0, angled, length 5 m for motor without brake for M200D, 4x1.5 mm ² for motor without brake for M200D with thermistor, 6x1.5 mm ² for motor with brake 400 V AC/180 V DC, 6 x 1.5 mm ² for motor with brake 400 V AC/180 V DC and thermistor, 8 x 1.5 mm ² for motor with brake 230 V AC, 6 x 1.5 mm ² for motor with brake 230 V AC and thermistor, 8 x 1.5 mm ²	3RK1911-0EB31 3RK1911-0EF31 3RK1911-0ED31 3RK1911-0EG31 3RK1911-0EH31 3RK1911-0EE31

Motor controller with AS-i communication

Designation	Order no.
Control cable, one end prefabricated/one end open, M12 angled cable plugs for screw mounting, IP67 degree of protection, 4-pin, 4 x 0.34 mm ² Cable length 5 m	3RK1902-4GB50-4AA0
Coupling plug with connection compartment, can be prefabricated, M12 angled cable plugs for screw mounting, IP67 degree of protection, 4-pin, 4 x 0.34 mm ²	3RK1902-4CA00-4AA0
AS-i M12 branch for flat cables AS-i/U _{AUX} , cable end in branch not possible M12 socket M12 cable box, cable length 1 m M12 cable box, cable length 2 m	3RK1901-1NR20 3RK1901-1NR21 3RK1901-1NR22
Cable end terminator for sealing open cable ends (AS-Interface shaped cable) with IP67 degree of protection	3RK1901-1MN00

Motor controller with IO communication

Designation	Order no.
Control cable, one end prefabricated/one end open, M12 angled cable connectors, degree of protection IP67, 5 x 0.34 mm ² (metal screw cap) Cable length 5 m Cable length 10 m	3RK1902-4HB50-5AA0 3RK1902-4HC01-5AA0
M12 coupler plug, straight, screw-type connection max. 0.75 mm ² , 5-pin, A-coded, max. 4 A	3RK1902-4BA00-5AA0
M12 coupler plug, angled, screw-type connection max. 0.75 mm ² , 5-pin, A-coded, max. 4 A	3RK1902-4DA00-5AA0

Further options

Designation	Order no.
M200D safety bars	3RK1911-3BA00
RS 232 interface cable	3RK1922-2BP00
USB interface cable	6SL3555-0PA00-2AA0
Hand-held device for motor starters for local control Serial interface cable must be ordered separately	3RK1922-3BA00
Diagnostics and commissioning tool Motor Starter ES 2007	3ZS1310-5CC10-0YA5
AS-i addressing unit in accordance with AS-Interface version 2.1 Scope of supply: Addressing unit, operating instructions, addressing cable (1.5 m with jack) Addressing cable M12 to M12 for addressing slaves with M12 connection	3RK1904-2AB02 3RK1902-4PB15-3AA0
Identification label 9 x 20, petrol (19 frames, 380 labels)	3RT1900-1SB50
M12 screw caps for sealing unassigned input/output sockets (one set contains 10 screw caps)	3RK1901-1KA00
Dismantling tool for Han Q4/2	3RK1902-0AB00
Dismantling tool for Han Q8/0	3RK1902-0AJ00

Bibliography

Documentation for M200D AS-i at a glance

All the documents in this overview are available for download at:

www.siemens.de/sirius-m200d

Each document has an **entry ID**, which you can use to search for a specific document.

The following tables list a selection of available AS-i documents.

Topic	AS-i master
Document title	AS-Interface system manual
Entry ID	26250840
For products	3RK11, 3RK12, 3RK14, 3RK21, 3RK22, 3RK24, 3RK3141, 3RX95, 6GK14, 6GK72, 6GK73
Document title	CP 343-2 / CP 343-2 P AS-Interface Master
Entry ID	5581657
For products	6GK7343-2AH00-0XA0; 6GK7343-2AH10-0XA0
Document title	Distributed I/O System DP/AS-i Link
Entry ID	1144898
For products	6GK1415-2AA00; 6GK1415-2AA01
Document title	ASiSafe DP/AS-i F-Link
Entry ID	24196041
For products	3RK3141-1CD10; 3RK3141-2CD10
Document title	Manual DP/AS-Interface Link Advanced
Entry ID	22710305
For products	6GK1415-BA10; 6GK1415-2BA20
Document title	Manual DP/AS-Interface Link 20E
Entry ID	5281638
For products	6GK1415-2AA01

Topic	M200D AS-i Basic motor starter
Document title	SIRIUS M200D AS-Interface Basic Manual
Entry ID	35016496
For products	3RK1315-6KS41-..., 3RK1315-6LS41-...

Topic	Addressing and analyzing
Document title	Addressing and Diagnosis Instrument for AS-i Modules
Entry ID	48532283
For products	3RK1904-2AB02
Document title	AS-Interface Analyzer
Entry ID	26267998
For products	3RK1904-3AB01

Topic	Control systems
Document title	S7-200 Automation System
Entry ID	1109582
For products	6ES7214; 6ES7221-1BF00-0XA0; 6ES7221-1EF00-0XA0; 6ES7221-1BF10-0XA0; 6ES7221-1JF00-0XA0; 6ES7222-1BF00-0XA0; 6ES7222-1HF00-0XA0; 6ES7222-1EF00-0XA0; 6ES7223-1BF00-0XA0; 6ES7215; 6ES7216; 6ES7223-1HF00-0XA0; 6ES7223-1EF00-0XA0; 6ES7223-1PH00-0XA0

Correction sheet



Correction sheet

Have you noticed any errors while reading this manual? If so, please use this form to tell us about them. We welcome comments and suggestions for improvement.

Fax response

To	From (please complete):
SIEMENS AG	Name
I IA CE MK&ST 3	Company/Department
92220 Amberg / Germany	Address

Fax: +49 (0)9621-80-3337

Manual title:

Table 8- 1 Errors, comments, and suggestions for improvements

Glossary

24 V-NS DC

Electronics supply voltage

24 V-S DC

Switching element supply voltage

AS-Interface (AS-i)

The AS-Interface (or actuator/sensor interface; abbreviated to AS-i) is a connection system for the lowest process level in automation systems.

BO

Brake output

Combined Transaction Type 2 (CTT2)

Communication protocol on AS-Interface in accordance with Specification V3.0 for the transfer of large volumes of data (analog values, strings, etc.).

Degree of protection

The degree of protection of a device indicates the extent of protection. The extent of protection includes the safety of persons against coming in contact with live or rotating parts, and the protection of electric resources against the penetration of water, foreign bodies and dust.

The M200D has an IP65 degree of protection when all the unused connections are sealed.

DSte

Abbreviation for "direct starter, electromechanical"

ESD

Components sensitive to electrostatic charge

Electronic components (e.g. field effect transistors, integrated circuits) that may be destroyed by high voltages (for instance by electrically charged non-grounded persons)

Ground fault

Fault whereby an external conductor comes into contact with ground or the grounded neutral point.

GSD

Device master data

GSDML

The GSDML language is defined by the GSDML scheme. A GSDML scheme contains validity rules that allow you to check the syntax of a GSD file, for example. Manufacturers of IO devices can obtain GSDML schemes (in the form of scheme files) from PROFIBUS International.

HMI

Operator control and monitoring
With HMI components, process data can be visualized and systems can be operated.

Integrated manual local control

Integrated manual local control is an orer variant for the M200D and involves a key-operated switch and keypad.

IP

Degrees of protection to DIN EN 60529 (IEC 529/VDE 047 T1)
(International Protection Classes)

LPS

List of configured slaves

MLFB

Machine-readable product designation

Motor Starter ES

The Motor Starter ES software is used for commissioning, parameterization, diagnostics, documentation, and preventive maintenance of the High Feature motor starters in the ranges:

- SIMATIC ET 200S (High Feature)
- ET 200pro
- ECOFAST (High Feature) and
- M200D (AS-i Standard, PROFIBUS, PROFINET)

N conductor (neutral conductor)

EN 60947-1: A conductor connected to the center point or neutral point of the system and designed to transfer electrical energy. EN 60050-141: Conductor in a multi-phase cable that is connected to the neutral point N) of a multi-phase combination.

PE (protective conductor)

- EN 60947-1: Conductor required for certain measures to protect against electric shock to establish an electrical connection between the following components:
 - Components of the electrical equipment
 - External, conductive components
 - Main grounding terminal
 - Ground electrode
 - Grounded point in the current source or artificial neutral point
- EN 60050-195: Conductor for safety purposes (e.g. to protect against electric shock).

PII/PIO

Process input image/process output image

Process image

Image of the signal states of the digital inputs and outputs in the memory of a controller.

PROFIBUS

PROFIBUS stands for "process fieldbus". PROFIBUS is a manufacturer-independent standard to network the field devices (e.g. PLCs, actuators, final controlling elements and sensors). PROFIBUS is compatible with protocols such as DP (decentralized peripherals), FMS (fieldbus message specification) and PA (process automation).

PROFIenergy

The PROFINET profile supports energy management systems in process plants by reading out measured values or by, for example, briefly shutting down the entire plant during breaks via standardized PROFIenergy commands.

PROFINET

This is an open component-based industrial communication system based on Ethernet for distributed automation systems. Communications technology required by the PROFIBUS User Organization.

Reversing starter

Starting control function for the direction of rotation (CW / CCW).

RSte

Abbreviation for "reversing starter, electromechanical"

sDSSte

Abbreviation for "direct soft starter, electronic"

sDSte

Direct starter (electronic)

Soft starter

Function for starting/stopping motors smoothly.

sRSSte

Abbreviation for "reversing soft starter, electronic"

sRSte

Reversing starter (electronic)

Step 7

The basic STEP 7 software is the standard tool for the SIMATIC S7, SIMATIC C7 and SIMATIC WinAC automation systems.

Trip class (shutdown class)

The trip class defines the start time at a particular current before the trip occurs. Different classes exist (e.g. CLASS 10, 20, 30, etc.), whereby CLASS 30 is the longest permissible start time.

Index

A

- Absolute current load, 88
- Accessories, 13
- Acknowledging, 142
- Acknowledgment, 74
- Addressing, 94
- Addressing unit, 95, 140
- Ambient temperature T_a , 88
- AS-i address
 - setting, 94
- AS-Interface, 10, 11
 - Connection options, 106
 - Installation guidelines, 107
 - Pin assignment, 106
- Assigning parameters, 115
- Asymmetry, 51

B

- Bibliography, 185
- Blocking current monitoring, 48
- Blocking protection, 49
- Blocking time, 48
- Brake holding time, 38
- Brake output, 36, 102
- Brake release delay, 37

C

- Cables, 97
- Circuit breaker, 17
- Cold run, 82
- Commands
 - Meaning, 72
- Commissioning, 130
 - Requirements, 128
- Communication, 65
- Configuring
 - Standard starter, 110
- Connection, 97
- Connection monitoring, 71
- Connections
 - Control circuit/bus, 18
 - Power connections, 18

- Connector monitoring, 62
 - Motor connector, 63
 - Power connector, 62
- Control function
 - Reversing starter, 31
 - Soft starter, 32
- Cooling, 42
- Correction sheet, 187
- CPU/Master STOP, 29
- Current limit, 47
- Current limit value, 35

D

- Data channels, 70
- Deactivation rule, 41
- Derating, 88
 - Diagrams, 89
 - Factors, 88
- Design concept, 16
- Device errors, 135
- Device function
 - Communication, 65
 - Inputs, 52
 - Outputs, 60
- Device functions
 - Introduction, 24
 - Overview, 14, 23
- Device interface, 83
- Device parameter
 - Overview, 116
- Device status, 19, 135
- Diagnostics, 131
 - Sample program, 140
 - Via parameter channel, 137
 - With LEDs, 132
- Diagnostics unit, 140
- Digital inputs
 - Pin assignment, 105
- Digital inputs/outputs, 104
 - Socket assignment, 104
- Digital output, 105
- Dimension drawing, 158
- Disconnecting means, 17
- DStE, 9, 13

E

EMC resistance, 93
Emergency start, 76

F

Factory settings, 78
Fault
 Acknowledging, 142
FE, 93
Fieldbus interface, 74
Functional ground, 93

G

General messages, 74
Group diagnostics, 29
Group fault, 136
Group fault message, 29

H

Han Q4/2 socket, 101
Han Q8/0 pin, 101

I

ID1 code, 95, 110, 120
Idle time, 42
Input
 n action, 54
 n level, 54
 n signal, 53
 Signal delay, 53
 Signal extension, 53
Input function, 53
Input process image (PII), 120
Installation, 87
 of the motor starter, 93
 Protection guard, 92
Installation position, 87
Installation rules, 87
Integrated manual local control, 17, 84
 Automatic mode, 84
 Clockwise rotation, 85
 Continuous operation / jog mode, 85
 Counterclockwise rotation, 85
 Key-operated switch, 84
 Keypad, 85
 Manual mode, 84

OFF / Reset, 84
Quick stop disable, 85

L

Load type, 27
Logbook, 75
 Device errors, 75
 Events, 75
 Triggering operations, 75

M

Main power monitoring, 80
Manual mode local, 71
Master requirements, 109
MLFB, 179
Mode, 135
Mode monitoring, 74
Modes, 70
Motor heating, 41
Motor starter
 Connection examples, 107
 Connection options, 106
Motor Starter ES, 125

O

On time motor, 148
Operator controls, 17
Order numbers, 179
 Accessories, 181
 Spare parts, 181
Order variants, 13
Output
 n action, 61
 n level, 60
 n signal, 60
Output process image (PIO), 122

P

Parameter assignment, 74
Parameter bits, 115
Parameter echo, 137
Plausibility check, 73
Potential transfer, 104
Power cables, 97
Power connector, 62
Power connectors, 99

Power terminal
 Motor connection, 100
 Power supply, 100
Process image, 120, 123
PROFIBUS, 10
PROFINET, 10
Protection against voltage failure, 28
Protection guard, 92

Q

Quick stop, 57

R

Rated operating current, 25
Recovery time, 41
Remaining time for tripping, 41
Required components, 129
Residual current detection, 47
Response
 to circuit breaker OFF, 64
 To faults, 141
 to overload, 39
 When connector removed, 63
Restart, 39, 45, 76
RStE, 9, 13
Run-down time, 34
Run-down type, 34

S

sDSStE, 9, 13
sDStE, 13, 149
Self-protection, 25
Self-test, 77
Service life
 Contactor, 156
Setting values
 Temperature sensor, 46
Settings
 Connector monitoring, 63
Short-circuit protection
 Circuit breaker / disconnecting means, 64
 Circuit breakers, 64
Siemens Solution Partner, 97
Soft run-down, 33
sRSStE, 9, 13
sRStE, 13, 149
Start time, 34
Starting voltage, 34

Startup mode, 34
Startup parameter data sets, 30
Status indicators, 19
Stopping voltage, 35
Supply voltage failure, 28
Switching, 81
System error, 136

T

Technical data
 Inputs, 146
 Motor starters, 144
 Output, 147
Technical specifications
 Brake control, 146
 General, 143
 Thermistor motor protection, 147
Temperature sensor, 45
 Monitoring, 45
 PTC type A, 45
 Setting values, 46
 Thermoclick, 45
Thermal motor model, 39
Trip class, 40
Trip reset, 77

W

Wiring, 97
 Power cables, 98
 Power connectors, 99

Service & Support

SIRIUS M200D

www.siemens.com/sirius-m200d

Download catalogs and information material:

www.siemens.com/sirius/infomaterial

Newsletter - always up to date:

www.siemens.com/sirius/newsletter

E-Business in the Industry Mall:

www.siemens.com/sirius/mall

Online-Support:

www.siemens.com/sirius/support

Contact for all technical information:

Technical Assistance

Tel.: +49 (911) 895-5900

e-mail: technical-assistance@siemens.com

www.siemens.com/sirius/technical-assistance

Siemens AG
Industry Sector
Postfach 23 55
90713 FUERTH
GERMANY

Subject to change without prior notice
3ZX1012-0RK13-2AC1

© Siemens AG 2009



www.siemens.com/automation