

RFID SYSTEMS

MOBY D

System Manual · 01/2010

SIMATIC Sensors

Answers for industry.

SIEMENS

SIEMENS

SIMATIC Sensors

RFID systems MOBY D

System Manual

Introduction	1
Safety information/instructions	2
System overview	3
Planning the MOBY D system	4
Mobile data storage units	5
Write/read devices with RS232 interface	6
Write/read devices with RS422 interface	7
Antennas	8
System integration	9
Accessories	10
Alarm, error and system messages	11
Troubleshooting/FAQ	12
Certificates and approvals	A
Service & Support	B
Previous versions	C
List of abbreviations	D

Legal information

Warning notice system

This manual contains notices you have to observe in order to ensure your personal safety, as well as to prevent damage to property. The notices referring to your personal safety are highlighted in the manual by a safety alert symbol, notices referring only to property damage have no safety alert symbol. These notices shown below are graded according to the degree of danger.

⚠ DANGER
indicates that death or severe personal injury will result if proper precautions are not taken.
⚠ WARNING
indicates that death or severe personal injury may result if proper precautions are not taken.
⚠ CAUTION
with a safety alert symbol, indicates that minor personal injury can result if proper precautions are not taken.
CAUTION
without a safety alert symbol, indicates that property damage can result if proper precautions are not taken.
NOTICE
indicates that an unintended result or situation can occur if the corresponding information is not taken into account.

If more than one degree of danger is present, the warning notice representing the highest degree of danger will be used. A notice warning of injury to persons with a safety alert symbol may also include a warning relating to property damage.

Qualified Personnel

The product/system described in this documentation may be operated only by **personnel qualified** for the specific task in accordance with the relevant documentation for the specific task, in particular its warning notices and safety instructions. Qualified personnel are those who, based on their training and experience, are capable of identifying risks and avoiding potential hazards when working with these products/systems.

Proper use of Siemens products

Note the following:

⚠ WARNING
Siemens products may only be used for the applications described in the catalog and in the relevant technical documentation. If products and components from other manufacturers are used, these must be recommended or approved by Siemens. Proper transport, storage, installation, assembly, commissioning, operation and maintenance are required to ensure that the products operate safely and without any problems. The permissible ambient conditions must be adhered to. The information in the relevant documentation must be observed.

Trademarks

All names identified by ® are registered trademarks of the Siemens AG. The remaining trademarks in this publication may be trademarks whose use by third parties for their own purposes could violate the rights of the owner.

Disclaimer of Liability

We have reviewed the contents of this publication to ensure consistency with the hardware and software described. Since variance cannot be precluded entirely, we cannot guarantee full consistency. However, the information in this publication is reviewed regularly and any necessary corrections are included in subsequent editions.

Table of contents

1	Introduction	13
1.1	Preface.....	13
1.2	Navigating in the system manual.....	15
1.3	Overview.....	16
1.4	Main applications.....	17
2	Safety information/instructions	19
2.1	General safety instructions.....	19
3	System overview	21
3.1	System overview for MOBY D.....	21
4	Planning the MOBY D system	25
4.1	Fundamentals of application planning.....	25
4.1.1	Transmission window and read/write distance.....	25
4.1.2	Width of the transmission window.....	27
4.1.3	Transmission window with auxiliary fields.....	27
4.1.4	Permissible directions of motion of the MDS.....	29
4.1.5	Operation in static and dynamic mode.....	30
4.1.6	Communication between ASM, write/read device and MDS.....	31
4.1.7	Tolerance of tracking of pallet.....	32
4.2	Field data.....	33
4.2.1	Field data for MDS and SLG.....	33
4.2.2	Minimum spacing.....	37
4.3	Installation guidelines.....	38
4.3.1	Overview.....	38
4.3.2	Permissible mounting material.....	38
4.3.3	Metal-free area.....	40
4.3.4	Influences affecting the transmission window.....	43
4.3.4.1	MDS in metal-free environment.....	49
4.3.4.2	MDS in the vicinity of metal.....	50
4.3.5	Reduction of interference due to metal.....	51
4.3.6	Mounting of multiple antennas on or between metal frames.....	53
4.3.7	Installation and interconnection of 2, 3 or 4 MOBY D antennas to one SLG D10/D10S write/read device.....	54
4.4	Chemical resistance of the MDS.....	61
4.5	EMC Guidelines.....	68
4.5.1	Overview.....	68
4.5.2	What does EMC mean?.....	69
4.5.3	Basic rules.....	70
4.5.4	Propagation of electromagnetic interference.....	71
4.5.5	Cabinet configuration.....	75
4.5.6	Prevention of interference sources.....	78
4.5.7	Equipotential bonding.....	79
4.5.8	Ground-fault monitoring with MOBY.....	80

4.5.9	Cable shielding.....	81
4.6	MOBY shield concept.....	83
4.7	Cable and connector assignment	85
4.7.1	Cable configuration	85
4.7.2	Connector pin assignment for SLG D1x (RS232).....	86
4.7.3	Connector pin assignment for D1xS (RS422).....	88
4.7.4	Connecting cable	90
5	Mobile data storage units.....	95
5.1	Introduction	95
5.2	Memory configuration of the ISO tags	98
5.3	MDS D100.....	99
5.3.1	Characteristics	99
5.3.2	Ordering data	99
5.3.3	Metal-free area.....	99
5.3.4	Mounting options.....	101
5.3.5	Technical data.....	104
5.3.6	Dimension drawing.....	105
5.4	MDS D124.....	106
5.4.1	Characteristics	106
5.4.2	Ordering data	106
5.4.3	Mounting on metal.....	106
5.4.4	Technical specifications	108
5.4.5	Dimension drawing.....	109
5.5	MDS D139.....	110
5.5.1	Characteristics	110
5.5.2	Ordering data	110
5.5.3	Mounting on metal.....	111
5.5.4	Technical specifications	113
5.5.5	Use of the MDS D139 in potentially explosive environments	114
5.5.6	Dimensional drawing.....	116
5.5.7	Cleaning the mobile data memory	116
5.6	MDS D160.....	117
5.6.1	Characteristics	117
5.6.2	Ordering data	117
5.6.3	Mounting on metal.....	118
5.6.4	Technical specifications	119
5.6.5	Dimension drawing.....	120
5.7	MDS D165.....	121
5.7.1	Features	121
5.7.2	Ordering data	121
5.7.3	Technical data.....	122
5.7.4	Dimension drawing.....	123
5.8	MDS D200.....	124
5.8.1	Features	124
5.8.2	Ordering data	124
5.8.3	Mounting on metal.....	125
5.8.4	Technical data.....	127
5.8.5	Dimension drawing.....	128
5.9	MDS D261.....	129

5.9.1	Features	129
5.9.2	Ordering data	129
5.9.3	Technical data	130
5.9.4	Dimension drawing	131
5.10	MDS D324.....	132
5.10.1	Characteristics	132
5.10.2	Ordering data	132
5.10.3	Metal-free area	133
5.10.4	Technical specifications	134
5.10.5	Dimension drawing	135
5.11	MDS D424.....	136
5.11.1	Characteristics	136
5.11.2	Ordering data	136
5.11.3	Mounting on metal	136
5.11.4	Technical specifications	138
5.11.5	Dimension drawing	139
5.12	MDS D428.....	140
5.12.1	Characteristics	140
5.12.2	Ordering data	140
5.12.3	Application example of MDS D428	141
5.12.4	Technical specifications	142
5.12.5	Dimension drawing	143
5.13	MDS D460.....	144
5.13.1	Characteristics	144
5.13.2	Ordering data	144
5.13.3	Mounting on metal	145
5.13.4	Technical specifications	146
5.13.5	Dimension drawing	147
6	Write/read devices with RS232 interface	149
6.1	Overview of SLG with RS 232 serial interface	149
6.2	SLG D10 basic unit	153
6.2.1	Features	153
6.2.2	Ordering data	153
6.2.3	Technical data	154
6.2.4	FCC information	155
6.2.5	Dimension drawing	156
6.3	SLG D11 basic unit	157
6.3.1	Features	157
6.3.2	Ordering data	157
6.3.3	Technical specifications	158
6.3.4	FCC information	159
6.3.5	Dimension drawing	160
6.4	SLG D12	161
6.4.1	Features	161
6.4.2	Ordering data	161
6.4.3	Technical data	162
6.4.4	FCC information	163
6.4.5	Transmission window.....	164
6.4.6	Secondary fields	165
6.4.7	Influence of metal.....	166
6.4.8	Metal-free area	167

6.4.9	Minimum distances between several SLGs	168
6.4.10	Dimension drawing.....	169
7	Write/read devices with RS422 interface	171
7.1	Overview SLG with RS 422 for SIMATIC S7 and PROFIBUS DP-V1	171
7.2	SLG D10S basic unit.....	174
7.2.1	Features	174
7.2.2	Ordering data	175
7.2.3	Technical data	176
7.2.4	FCC information	177
7.2.5	Dimension drawing.....	178
7.3	SLG D11S basic unit.....	179
7.3.1	Features	179
7.3.2	Ordering data	180
7.3.3	Technical specifications	181
7.3.4	FCC information	182
7.3.5	Dimension drawing.....	183
7.4	SLG D12S	184
7.4.1	Features	184
7.4.2	Ordering data	185
7.4.3	Technical data.....	186
7.4.4	FCC information	187
7.4.5	Transmission window.....	188
7.4.6	Secondary fields.....	189
7.4.7	Influence of metal.....	190
7.4.8	Metal-free area.....	191
7.4.9	Minimum distances between several SLGs	192
7.4.10	Dimension drawing.....	193
7.5	SLG D12S (plug-in version)	194
7.5.1	Features	194
7.5.2	Ordering data	195
7.5.3	Technical specifications	196
7.5.4	Field data.....	197
7.5.5	Transmission window.....	198
7.5.6	Secondary fields.....	199
7.5.7	Influence of metal.....	200
7.5.8	Metal-free area.....	201
7.5.9	Minimum distances between several SLGs	202
7.5.10	Dimensional diagram	203
8	Antennas	205
8.1	ANT D2.....	205
8.1.1	Features	205
8.1.2	Ordering data	205
8.1.3	Technical specifications for ANT D2	206
8.1.4	Transmission window.....	207
8.1.5	Metal-free area.....	208
8.1.6	Minimum distance between several ANT D2 antennas	209
8.1.7	Dimension drawing.....	209
8.2	ANT D5.....	210
8.2.1	Features	210
8.2.2	Ordering data	210
8.2.3	Technical data.....	211

8.2.4	Transmission window.....	212
8.2.5	Metal-free area.....	213
8.2.6	Minimum distance between antennas	214
8.2.7	Dimension drawings.....	215
8.3	ANT D6	218
8.3.1	Features	218
8.3.2	Ordering data.....	218
8.3.3	Technical data.....	219
8.3.4	Transmission window.....	220
8.3.5	Metal-free area.....	221
8.3.6	Minimum distance between antennas	221
8.3.7	Dimension drawing	222
8.4	ANT D10	223
8.4.1	Features	223
8.4.2	Ordering data.....	223
8.4.3	Technical data.....	224
8.4.4	Transmission window.....	225
8.4.5	Metal-free area.....	226
8.4.6	Minimum distance between antennas	227
8.4.7	Dimension drawing	228
9	System integration.....	229
9.1	ASM 452	231
9.1.1	Application area	231
9.1.2	Features	231
9.1.3	Configuration.....	232
9.1.4	PROFIBUS DP communication	233
9.1.4.1	PROFIBUS DP configuring.....	233
9.1.4.2	Operating mode of the ASM 452	233
9.1.4.3	PROFIBUS DP diagnostics.....	233
9.1.4.4	PROFIBUS DP address and terminating resistor	234
9.1.5	Device connections	235
9.1.5.1	Reader connection system	235
9.1.5.2	Pin assignments.....	237
9.1.6	Cable.....	238
9.1.6.1	PROFIBUS DP cable with 24 V supply.....	238
9.1.6.2	Example of stripped lengths.....	238
9.1.7	Technical data.....	239
9.1.8	Dimension diagram	240
9.1.9	Ordering data	241
9.2	ASM 456	242
9.3	ASM 473	243
9.3.1	Application area	243
9.3.2	Features	243
9.3.3	Basic module - Requirements for operation of ASM 473	244
9.3.4	Configuration.....	245
9.3.5	Device connections.....	247
9.3.5.1	Reader connection system	247
9.3.5.2	Pin assignments.....	248
9.3.6	Technical data.....	250
9.3.7	Dimension diagram	251
9.3.8	Ordering data	252
9.4	ASM 475	253

9.4.1	Application area	253
9.4.2	Features	254
9.4.3	Configuration	254
9.4.4	Configuration	256
9.4.5	PROFIBUS DP communication	257
9.4.5.1	Diagnosis using LEDs	257
9.4.6	Device connections	258
9.4.6.1	Wiring to the SLG	258
9.4.6.2	Shield connection	259
9.4.6.3	Lightning protection	260
9.4.7	Cable	260
9.4.7.1	Cable assembly by the customer	260
9.4.8	Technical data	261
9.4.9	Ordering data	262
9.5	RF170C	263
9.6	RF180C	264
9.7	RF182C	265
10	Accessories	267
10.1	Wide-range power supply unit for SIMATIC RF systems	267
10.1.1	Features	267
10.1.2	Scope of supply	268
10.1.3	Ordering data	268
10.1.4	Safety Information	269
10.1.5	Connecting	271
10.1.6	Technical specifications	271
10.1.7	Pin assignment of DC outputs and mains connection	273
10.1.8	Dimension drawing	274
10.1.9	Certificates and approvals	275
10.2	Mobile handheld terminals	276
10.3	MOBY antenna distributor	277
11	Alarm, error and system messages	279
11.1	Error messages and causes for MOBY D in combination with the MDWAPI library	280
11.2	Error messages and causes for MOBY D with ASM and FC/FB 45 (direct MDS addressing)	282
11.2.1	General errors	282
11.2.2	Error messages	283
12	Troubleshooting/FAQ	293
A	Certificates and approvals	295
B	Service & Support	299
C	Previous versions	301
C.1	Previous MDS version with different MLFB	301
C.1.1	Compatibility list	301
C.1.2	MDS D124 (MLFB 6GT2600-0AC00)	302
C.1.3	MDS D139 (MLFB 6GT2600-0AA00)	306
C.2	Discontinued SLG with ANT D5	311
C.2.1	Compatibility list	311
C.2.2	SLG D10 ANT D5 (MLFB 6GT2601-0AA00)	311

C.2.3	SLG D11 ANT D5 (MLFB 6GT2601-0AC00)	319
C.2.4	SLG D10S ANT D5 (6GT2602-0AA00)	326
C.2.5	SLG D11S ANT D5 (6GT2602-0AC00)	333
D	List of abbreviations	341
	Glossary	343
	Index	347

Introduction

1.1 Preface

Objective of this documentation

This system manual contains all the information needed to plan and configure the system.

It is intended both for programming and testing/debugging personnel who commission the system themselves and connect it with other units (automation systems, further programming devices), as well as for service and maintenance personnel who install expansions or carry out fault/error analyses.

Scope of this document

This documentation is valid for all supplied versions of the MOBY D system and describes the state of delivery as of 01/2010.

History

Previous editions of these operating instructions:

Output	
01/2010	<ul style="list-style-type: none"> • MDS D165, MDS D200, MDS D261, MDS D324, MDS D424, MDS D428, MDS D460 • SIMATIC RF180C, RF182C interface modules • SLG D12S (plug-in version) • ANT D2
11/2006	Edition of a system manual with adaptation of the content structures Supplements: <ul style="list-style-type: none"> • SIMATIC RF170C interface module • Wide-range power supply unit for SIMATIC RF systems
09/2005	Edition of a system manual with adaptation of the content structures Supplements: <ul style="list-style-type: none"> • write/read device SLG D10/D10S basic unit • ANT D6m, ANT D10 antennas • ASM 456 interface module • MOBY antenna distributor
09/2003	Supplements: <ul style="list-style-type: none"> • MDS D100, MDS D124 mobile data storage unit • SLG D11S ANT D5; SLG D12S write/read devices
12/2002	Supplements: <ul style="list-style-type: none"> • Write/read device SLG D10S ANT D5 • ASM 452; ASM 473; ASM 475 interface modules
10/2002	First edition of the configuration manual

Conformity Certificates

The EC declaration of conformity and the corresponding documentation are made available to the appropriate authorities in accordance with EC directives. Your sales representative can provide these on request.

Observance of installation guidelines

Adhere to the installation guidelines and safety instructions given in this documentation during commissioning and operation.

1.2 Navigating in the system manual

Structure of contents	Contents
Table of contents	Organization of the documentation, including the index of pages and chapters
Introduction	Purpose, layout and description of the important topics.
Safety instructions	All generally valid safety-related aspects that <ul style="list-style-type: none"> • according to legal regulations • from a product/system viewpoint at installation, • at startup, • during operation have to be observed.
System overview	Overview of all RF identification systems, system overview of MOBY D
Planning the MOBY D system	Information regarding: <ul style="list-style-type: none"> • Possible applications of MOBY D • Support in application planning • Selection aids for finding the suitable MOBY D components.
Mobile data storage units	Description of the mobile data storage units (MDS) used for MOBY D
Write/read devices with RS232 interface	Description of the write/read devices (SLG) with RS232 interface used for MOBY D
Write/read devices with RS422 interface	Description of the write/read devices (SLG) with RS422 interface used for MOBY D
Antennas	Description of the external MOBY D antennas
System integration	Description of the interface modules (ASM) used for MOBY D
Accessories	Products supplied separately for MOBY D
Alarm, error and system messages	Overview of error messages
Troubleshooting/FAQ	Troubleshooting and error messages
Appendix	<ul style="list-style-type: none"> • Certificates and approvals • Service and support
Previous versions	List of components with a successor version or which have been discontinued.
List of Abbreviations	List of all abbreviations used in the document
Glossary	List of all terms used in the document
Index	Index

1.3 Overview

MOBY D is an RF identification system based on the ISO/IEC 15693 standard in the 13.56 MHz range. ISO/IEC 15693 creates a common basis for tags and Smartlabels from different manufacturers for the first time.

Application areas typically encompass the following:

- Replacement for electronic barcode
- Supplement to barcode or delivery note in harsh environments
- Warehouse and distribution logistics
- Product identification

MOBY D can be directly connected to a PC with Windows 9x Professional, 2000 Professional und NT Professional over a serial (RS 232) interface and is supported by a powerful C library.

It is integrated into SIMATIC S7 and PROFIBUS DP-V1 using the well-proven MOBY interface modules

- ASM 452
- ASM 456
- ASM 473
- ASM 475
- SIMATIC RF170C
- SIMATIC RF180C
- SIMATIC RF182C

An easy-to-operate interface is available to the S7 user.

With the MOBY D write/read device, the standardized, low-cost write/read transponders (Smartlabels based on ISO/IEC 15693) are processed at distances of up to 650 mm (depending on the size of transponder and antenna).

1.4 Main applications

The design of the transponder permits a variety of flexible designs, ensuring optimum dimensioning for the widest variety of applications.

Low-cost Smartlabels for large volume applications:

- Container and box identification in open systems
- Distribution logistics and goods identification
- Parcel and postal services, couriers and logistics companies
- Baggage check-in and baggage tracking

Up to 100 Smartlabels can be simultaneously detected (bulk detection) and the data can be selectively processed (multitag mode).

Rugged data storage units in closed processes:

- Container and box identification in logistics and distribution
- Production logistics and assembly lines with extreme temperature requirements (e.g. paintshops, temperature range up to +220 °C)
- Parts identification (e.g. data storage unit is attached directly to product/pallet).

Safety information/instructions

2.1 General safety instructions

SIMATIC RFID products comply with the salient safety specifications to IEC, VDE, EN, UL and CSA. If you have questions about the validity of the installation in the planned environment, please contact your service representative.

CAUTION
Alterations to the devices are not permitted. Failure to observe this requirement shall constitute a revocation of the radio equipment approval, CE approval and manufacturer's warranty.

Repairs

Repairs may only be carried out by authorized qualified personnel.

 WARNING
Unauthorized opening of and improper repairs to the device may result in substantial damage to equipment or risk of personal injury to the user.

System expansion

Only install system expansion devices designed for this device. If you install other upgrades, you may damage the system or violate the safety requirements and regulations for radio frequency interference suppression. Contact your technical support team or your sales outlet to find out which system upgrades are suitable for installation.

CAUTION
If you cause system defects by installing or exchanging system expansion devices, the warranty becomes void.

System overview

3.1 System overview for MOBY D

3.1 System overview for MOBY D

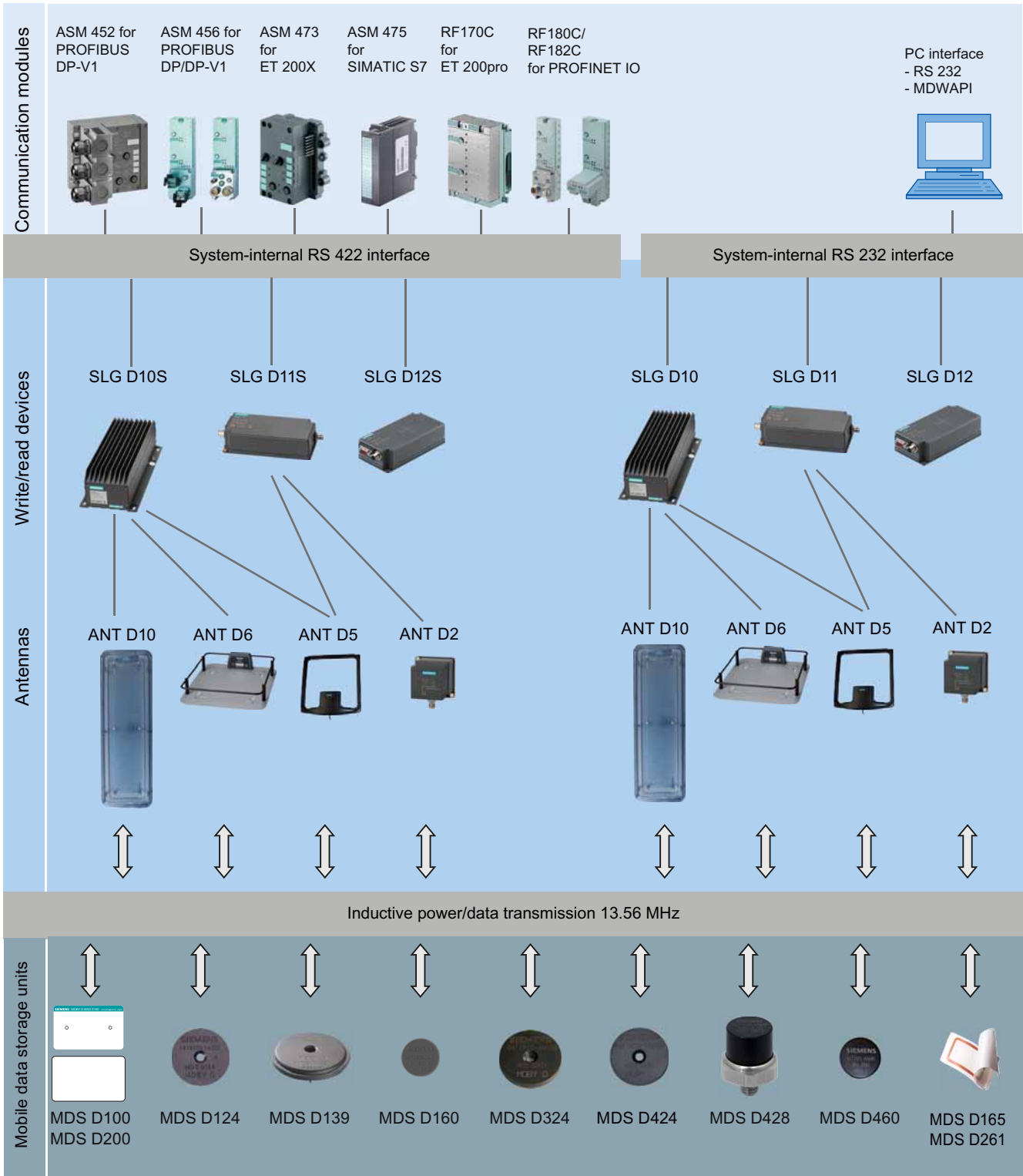

Figure 3-1 Overview of MOBY D components

Tags	SLG D10/D10S with			SLG D11/D11S with		SLG D12/D12S
	ANT D5	ANT D6	ANT D10	ANT D2	ANT D5	-
MDS D100	✓	✓	✓	○	✓	✓
MDS D124	✓	✓	✓	✓	✓	✓
MDS D139	✓	✓	✓	○	✓	✓
MDS D160	✓	✓	✓	✓	✓	✓
MDS D324	✓	✓	✓	✓	✓	✓
MDS D424	✓	✓	✓	✓	✓	✓
MDS D428	✓	✓	✓	○	✓	✓
MDS D460	✓	✓	✓	✓	✓	✓
MDS D165	✓	✓	✓	○	✓	✓
MDS D200	✓	✓	✓	○	✓	✓
MDS D261	✓	✓	✓	○	✓	✓

- ✓ Combination possible
- Combination possible, but not recommended

Planning the MOBY D system

4.1 Fundamentals of application planning

Assess your application according to the following criteria, in order to choose the right MOBY D components:

- Transmission distance (read/write distance)
- Data volume to be transferred
- Metal-free areas for MDS and SLG (antenna)
- Static or dynamic data transfer
- Speed in case of dynamic transfer
- Tracking tolerances
- Ambient conditions such as relative humidity, temperature, chemical impacts, etc.
- Maximum writes per MDS
- System connection

4.1.1 Transmission window and read/write distance

The write/read device (SLG) generates an inductive alternating field. The field is at its strongest near the antenna and declines rapidly as the distance from the antenna increases. The distribution of the field depends on the structure and geometry of the antennas in the write/read device and MDS.

A prerequisite for the function of the MDS is a minimum field strength at the MDS that is achieved at a distance S_g from the write/read device. The figures below show as an example the transmission window between the MDS and ANT D5 antenna (in this case always parallel alignment of MDS to antenna/SLG).

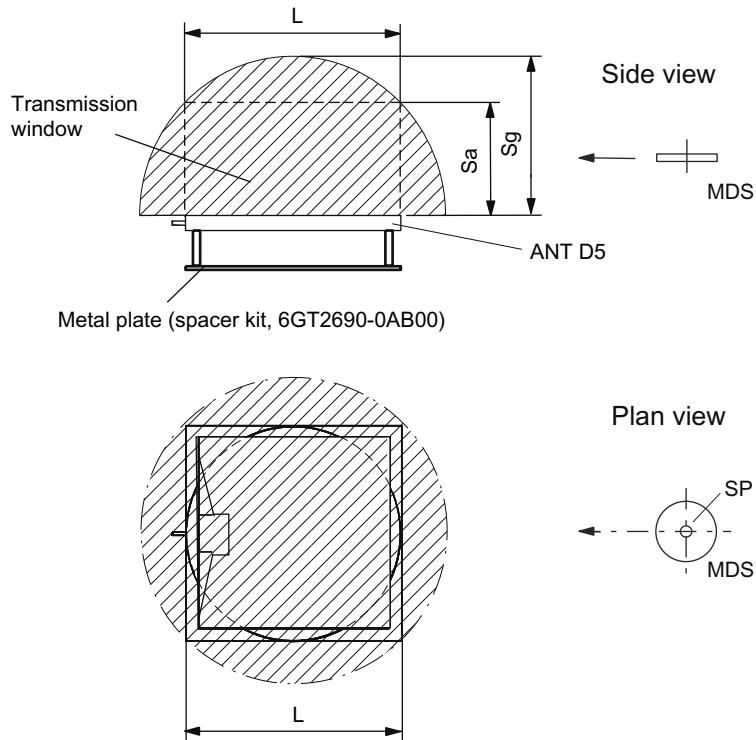

- S_a: Operating distance between MDS and SLG
- S_g Limit distance
(maximum clear distance between upper surface of antenna and MDS, at which the transmission can still function under normal conditions)
- L Length of the transmission window (300 mm)
- SP Crossover point of the axes of symmetry of the MDS

Figure 4-1 Transmission window based on the example of ANT D5

The active field to the MDS comprises a circle (ANT D5) or a square (ANT D6, D10; SLG D12/D12S). The MDS can be processed as soon as the crossover point (CP) of the MDS enters the circle or square of the transmission window. The direction of movement and rotation of the MDS has no effect.

From the diagrams above, it can also be seen that operation is possible within the area between S_a and S_g. The active operating area reduces as the distance increases, and shrinks to a single point at distance S_g. Only static mode should thus be used in the area between S_a and S_g.

For more detailed information on the transmission windows of the individual antennas, refer to the respective antenna or SLG chapters.

4.1.2 Width of the transmission window

Determining the width of the transmission window

The following approximation formula can be used for practical applications:

- W: Width of transmission window (median deviation)
L: Length of the transmission window

Tracking tolerance

The width of the transmission window (W) is particularly important for the mechanical tracking tolerance. The formula for the dwell time is valid without restriction when W is observed.

4.1.3 Transmission window with auxiliary fields

In general, auxiliary fields always exist. They can be found outside the antenna conductor loop and must be used for configuring only in exceptional cases since the write/read distances are limited.

In the case of parallel movement of the MDS with a short operating distance through the antenna field, a transmission-free space is traversed when moving from the auxiliary field to the main field and also when exiting the main field (multiple presence change possible). Precise information on the field geometries of the auxiliary fields cannot be given since the values depend heavily on the operating distance and the application area.

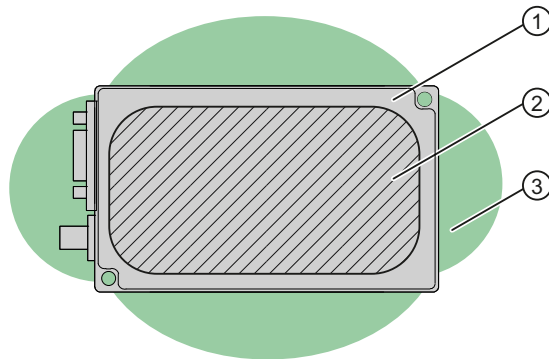

- ① SLG
- ② Main field
- ③ Secondary fields

Figure 4-2 Transmission window with auxiliary fields for SLG

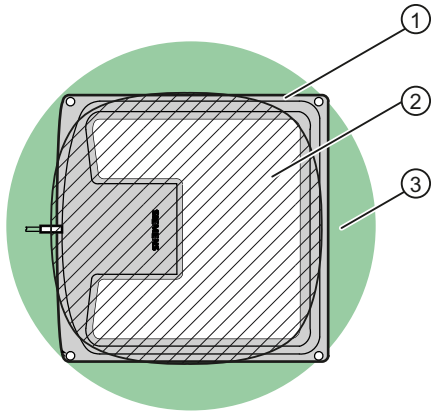

- ① Antenna
- ② Main field
- ③ Secondary fields

Figure 4-3 Transmission window with auxiliary fields for antennas

4.1.4 Permissible directions of motion of the MDS

Coverage area of antenna and direction of motion of MDS

The MDS and antenna have **no** polarization axis, i.e. the MDS can come in from any direction, be placed at any position, and cross the transmission window. The data of the transmission window do not differ. The figure below shows the coverage area of the antenna for various directions of MDS motion:

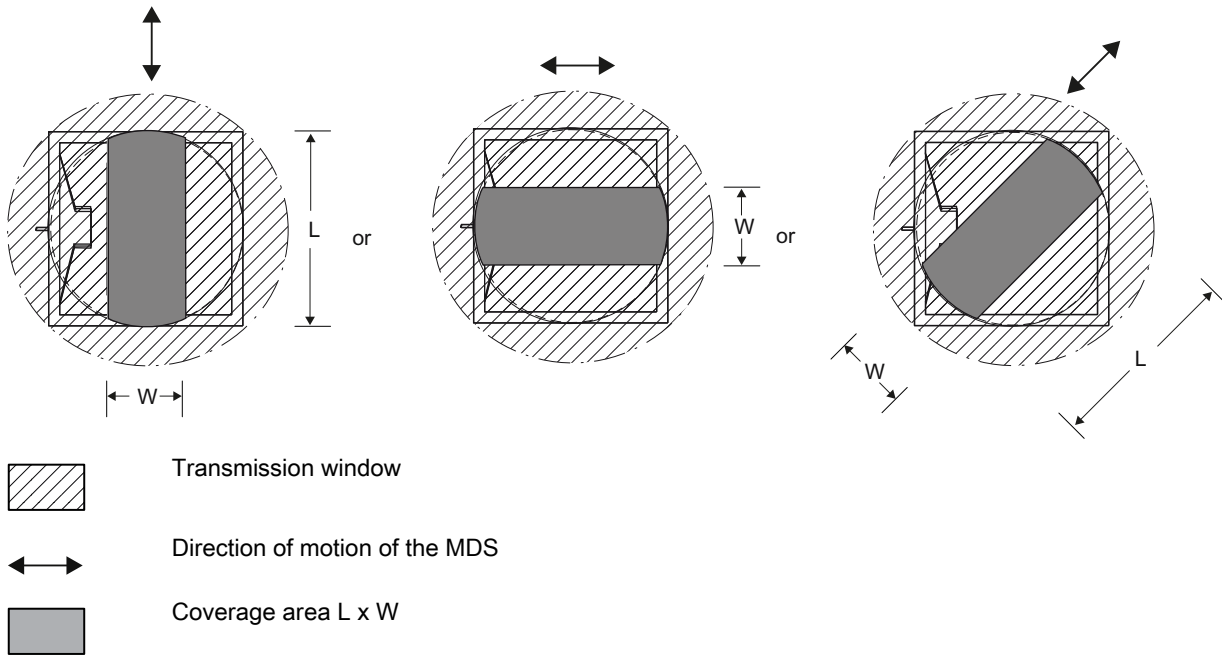

Figure 4-4 Coverage areas of antenna/detection area of SLG for different directions of MDS motion

4.1.5 Operation in static and dynamic mode

Operation in static mode

If working in static mode, the MDS can be operated up to the limit distance (S_g). The MDS must then be positioned exactly over the SLG or the antenna:

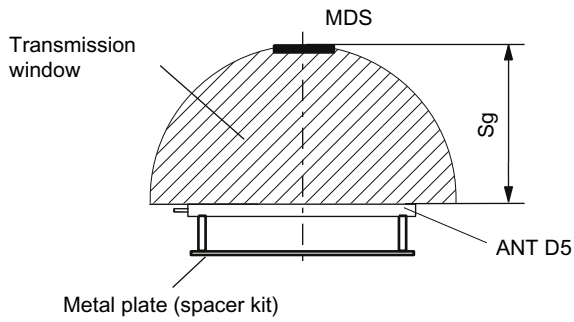

Figure 4-5 ANT D5: Operation in static mode

Operation in dynamic mode

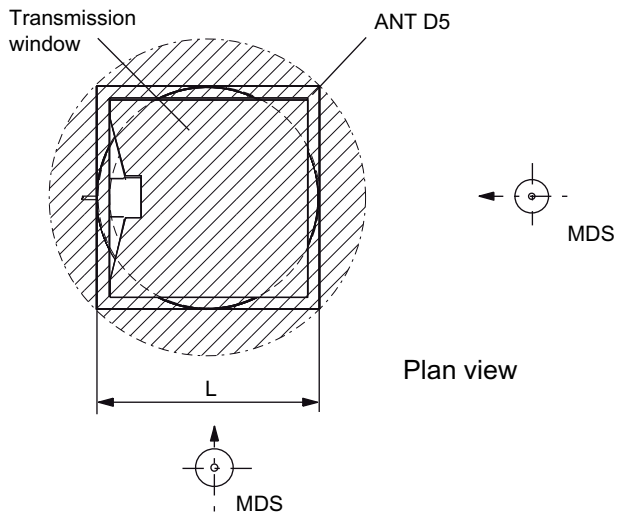

Figure 4-6 ANT D5: Operation in dynamic mode

4.1.6 Communication between ASM, write/read device and MDS

Communication with the SLG is asynchronous with a transmission rate of

- 19.2 Kbaud with SLG D11S/SLG D12S
- 38.4 Kbaud with SLG D11/SLG D12
- 115.2 Kbaud with SLG D10/SLG D10S

Table 4- 1 Data transmission rate

	with MDS D1xx/MDS D2xx/MDS D3xx	with MDS D4xx
reading	≥ 2.5 ms/byte	≤ 2.5 ms/byte
Writing	≥ 9.5 ms/byte	

Table 4- 2 Transfer time for UID number (8 bytes)

SLG	Transmission time
SLG D11S/SLG D12S	60 ms (at 19.2 Kbaud)
SLG D11/SLG D12	60 ms (at 38.4 Kbaud)
SLG D10/SLG D10S	50 ms (at 115.2 Kbaud)

Table 4- 3 Traversing speed for SLG D1x / ANT Dx (with one transponder in the field)

	SLG D10			SLG D11		SLG D12	SLG D10S			SLG D11S		SLG D12S
	ANT D10*	ANT D6	ANT D5	ANT D2	ANT D5		ANT D10*	ANT D6	ANT D5	ANT D2	ANT D5	
UID number (8 bytes)	≤ 15	≤ 8.0	≤ 5.0	≤ 1.2	≤ 3.5	≤ 2.5	≤ 6.0	≤ 3.8	≤ 2.0	≤ 0.4	≤ 1.0	≤ 0.8
ISO tags, e.g. MDS D100												
Read (with 4 bytes user data / 1 block)	≤ 10	≤ 6.0	≤ 3.5	≤ 1.2	≤ 1.6	≤ 1.2	≤ 6.5	≤ 4.0	≤ 2.2	≤ 0.4	≤ 3.0	≤ 1.4
Write (with 4 bytes user data / 1 block)	≤ 9	≤ 5.5	≤ 3.0	≤ 0.2	≤ 1.2	≤ 1.0	≤ 5.5	≤ 3.4	≤ 1.8	≤ 0.3	≤ 2.8	≤ 1.2
Read (with 112 bytes of complete user data)	≤ 7.5	≤ 4.0	≤ 2.4	≤ 0.4	≤ 1.4	≤ 0.8	≤ 5.0	≤ 3.0	≤ 1.6	≤ 0.2	≤ 2.2	≤ 1.0
Write (with 112 bytes of complete user data)	≤ 2.0	≤ 1.0	≤ 0.6	≤ 0.1	≤ 0.4	≤ 0.2	≤ 2.0	≤ 1.0	≤ 0.6	≤ 0.1	≤ 0.5	≤ 0.2

All values in the table in m/s

* Traversing speed in lateral direction as for SLG D10 ANT D5/SLG D10S ANT D5

4.1.7 Tolerance of tracking of pallet

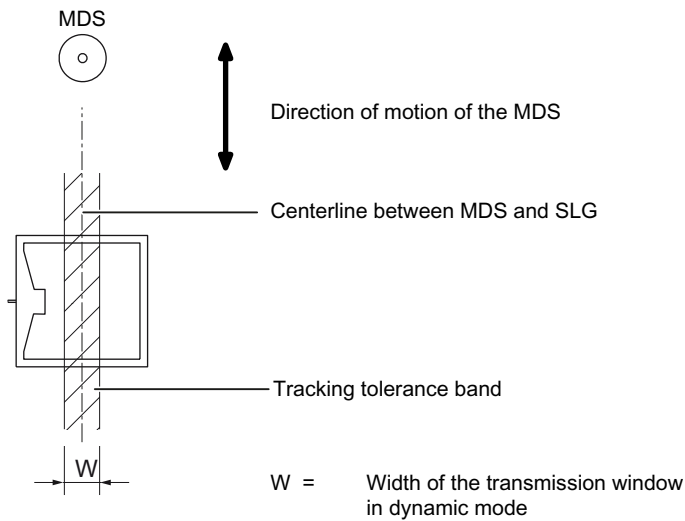

Figure 4-7 Example ANT D5: Tolerance of tracking of pallet

Determining the width of the transmission window

The following approximation formula can be used for practical applications:

$$B = 0.4 \cdot L$$

W: Width of the transmission window in dynamic mode

L: Length of the transmission window

Figure 4-8 Formula: Width of the transmission window

Tracking tolerance

The width of the transmission window (W) is particularly important for the mechanical tracking tolerance.

4.2 Field data

4.2.1 Field data for MDS and SLG

The field data of the MDS and SLG are shown in the table below. Thus it becomes particularly easy to select the right MDS and SLG. All the technical specifications listed are typical data and are applicable for the respective operating temperature of the MDS and SLG used (see Technical data of the MDS and SLG used). **Tolerances of $\pm 20\%$ are admissible due to production and temperature conditions.**

Note

In order to ensure optimum field data even in the vicinity of metal, ANT D5 is calibrated at the factory at a distance of 100 mm from metal.

Note

The field data for the following MDS is only valid with a corresponding order number:

- MDS D100 with order number 6GT2600-0AD10
 - MDS D124 with order number 6GT2600-0AC10
 - MDS D139 with order number 6GT2600-0AA10
 - MDS D160 with order number 6GT2600-0AB10
-

SLG D10/D10S with ANT D5

Table 4- 4 SLG D10/D10S with ANT D5

	Diameter of the transmission window (L_d)	Operating distance (S_a)	Limit distance (S_g)
MDS D100	\varnothing 320	0...400	500
MDS D124	\varnothing 300	0...200	280
MDS D139	\varnothing 320	0...400	500
MDS D160	\varnothing 300	0...130	180
MDS D324	\varnothing 300	0...200	280
MDS D424	\varnothing 300	0...200	280
MDS D428	\varnothing 300	0...120	160
MDS D460	\varnothing 300	0...120	160
MDS D165	\varnothing 320	0...350	450
MDS D200	\varnothing 320	0...400	500
MDS D261	\varnothing 320	0...300	400

All values are in mm

SLG D10/D10S with ANT D6

Table 4- 5 SLG D10/D10S with ANT D6

	Length of the transmission window		Operating distance (S _a)	Limit distance (S _g)
	in the X direction (L _x)	in the Y direction (L _y)		
MDS D100	520	420	0...550	650
MDS D124	500	400	0...220	300
MDS D139	520	420	0...500	600
MDS D160	500	400	0...130	180
MDS D324	500	400	0...200	280
MDS D424	500	400	0...220	300
MDS D428	500	400	0...100	150
MDS D460	500	500	0...100	150
MDS D165	520	420	0...400	500
MDS D200	520	420	0...500	600
MDS D261	520	420	0...350	400

All values are in mm

SLG D10/D10S with ANT D10

Table 4- 6 SLG D10/D10S with ANT D10

	Length of the transmission window		Operating distance (S _a)	Limit distance (S _g)
	in the X direction (L _x)	in the Y direction (L _y)		
MDS D100	1050	350	0...500	600
MDS D124	1000	300	0...200	280
MDS D139	1050	350	0...450	550
MDS D160	1000	300	0...130	180
MDS D324	1000	300	0...200	280
MDS D424	1000	300	0...200	280
MDS D428	1000	300	0...100	150
MDS D460	1000	300	0...100	150
MDS D165	1050	350	0...350	450
MDS D200	1050	350	0...450	550
MDS D261	1050	350	0...300	400

All values are in mm

SLG D11/D11S with ANT D2

Table 4- 7 SLG D11/D11S with ANT D2

	Length of the transmission window (L)	Operating distance (S _a)	Limit distance (S _g)
MDS D124	60	45...70	90
MDS D160	50	35...55	65
MDS D324	50	35...60	70
MDS D424	60	45...70	90
MDS D460	50	30...50	60

All values are in mm

SLG D11/D11S with ANT D5

Table 4- 8 SLG D11/D11S with ANT D5

	Diameter of the transmission window (L _d)	Operating distance (S _a)	Limit distance (S _g)
MDS D100	∅ 300	0...300	380
MDS D124	∅ 280	0...150	220
MDS D139	∅ 300	0...280	350
MDS D160	∅ 280	0...75	110
MDS D324	∅ 280	0...120	160
MDS D424	∅ 280	0...150	200
MDS D428	∅ 280	0...70	100
MDS D460	∅ 280	0...70	100
MDS D165	∅ 300	0...220	300
MDS D200	∅ 300	0...220	320
MDS D261	∅ 300	0...200	280

All values are in mm

SLG D12/D12S/D12S plug-in version

Table 4- 9 SLG D12/D12S

	Length of the transmission window		Operating distance (S _a)	Limit distance (S _g)
	in the X direction (L _x)	in the Y direction (L _y)		
MDS D100	120	60	0...160	220
MDS D124	120	60	0...70	100
MDS D139	120	60	0...120	150
MDS D160	120	60	0...45	65
MDS D324	120	60	0...60	80
MDS D424	120	60	0...70	100
MDS D428	120	60	0...40	60
MDS D460	120	60	0...40	60
MDS D165	120	60	0...120	150
MDS D200	120	60	0...120	160
MDS D261	120	60	0...100	140

All values are in mm

4.2.2 Minimum spacing

Table 4- 10 Minimum distance from MDS to MDS (without multitag mode)

		MDS D100 / MDS D139 / MDS D165 / MDS D200 / MDS D261	MDS D124 / MDS D160 / MDS D324 / MDS D424 / MDS D428 / MDS D460
SLG D10/D10S	ANT D5	≥ 1 m	≥ 0.8 m
	ANT D6	≥ 1.5 m	≥ 1.2 m
	ANT D10	≥ 2 m	≥ 1.8 m
SLG D11/D11S	ANT D2		
	• Horizontal main field	--	≥ 0.4 m
	• Vertical main field	--	≥ 0.1 m
	ANT D5	≥ 1 m	≥ 0.8 m
SLG D12/SLG D12S/ SLG D12S (plug-in version)		≥ 0.3 m	≥ 0.5 m

Reduction of the minimum spacing in multitag mode is permitted (SLG D10/SLG D11/SLG D12, RS232).

Table 4- 11 Minimum distance from SLG to SLG (antennas)

		SLG D10/ SLG D10S			SLG D11/ SLG D11S		SLG D12/ SLG D12S/ SLG D12S (plug-in version)
		ANT D5	ANT D6	ANT D10	ANT D2	ANT D5	
SLG D10/ SLG D10S	ANT D5	≥ 2 m	≥ 2 m	≥ 2 m	≥ 1 m	≥ 2 m	≥ 1 m
	ANT D6	≥ 2 m	≥ 2 m	≥ 2 m	≥ 1 m	≥ 2 m	≥ 1 m
	ANT D10	≥ 2 m	≥ 2 m	≥ 2 m	≥ 1 m	≥ 2 m	≥ 1 m
SLG D11/SLG D11S	ANT D2	≥ 1 m	≥ 1 m	≥ 1 m	≥ 0.5 m	≥ 0.8 m	≥ 0.8 m
	ANT D5	≥ 2 m	≥ 2 m	≥ 2 m	≥ 0.8 m	≥ 2 m	≥ 1 m
SLG D12/SLG D12S/ SLG D12S (plug-in version)		≥ 1 m	≥ 1 m	≥ 1 m	≥ 0.8 m	≥ 1 m	≥ 1 m

NOTICE

Extension of the data transmission time if distance values are undershot

If the distance values specified in the tables are undershot, it is possible that the inductive fields will be affected. In this case, the data transmission time can increase unpredictably or a command is aborted with an error.

For this reason, please observe the values in the tables.

4.3 Installation guidelines

4.3.1 Overview

The MDS and SLG are inductive devices. Any type of metal, in particular iron and ferromagnetic materials, in the vicinity of these devices will affect their operation. Some points need to be considered during planning and installation if the field data described in the preceding chapter are to retain their validity:

- The use of permissible mounting material
- The minimum distance between two antennas (see chapter "Antennas (Page 205)")
- The minimum distance between two adjacent MDS (see chapter "Mobile data storage units (Page 95)")
- The metal-free area for flush-mounting of SLGs in metal
- Mounting of multiple antennas on metal frames or racks

The following sections describe the impact on the functionality of the MOBY D identification system when mounted in the vicinity of metal.

4.3.2 Permissible mounting material

Securing SLG and antennas

In order to comply with UL guidelines, the components must only be secured with the fixing materials described below.

The positions of the fixing holes for the device are shown in the *Dimension drawings* section.

Fixing to metal

Table 4- 13 Fixing the SLG and antennas to metal

SLG/antenna	Screw type ¹
SLG D11, SLG D11S; SLG D12, SLG D12S; Antenna duplexer	M5 x 8, 8.8, DIN ISO 4017
SLG D10, SLG D10S	M6 x 8, 8.8, DIN ISO 4017
Antenna ANT D5	M6 x 8, 8.8, DIN ISO 4017
ANT D6 antenna	M6 x 8, 8.8, DIN ISO 4017
ANT D10 antenna	M6 x 8, 8.8, DIN ISO 4017

¹⁾ Represents minimum length

Fixing to reinforced concrete

Table 4- 14 Fixing the SLG and antennas to reinforced concrete

SLG/antenna	Screw type ¹	Plug type (nylon)
SLG D11, SLG D11S; SLG D12, SLG D12S; Antenna duplexer	5 x 40 mm	6 mm, e.g. fischer S6, Type No.: 50106
SLG D10, SLG D10S	6 x 40 mm	8 mm, e.g. fischer S8, Type No.: 50108
Antenna ANT D5	5 x 40 mm	6 mm, e.g. fischer S6, Type No.: 50106
ANT D6 antenna	6 x 40 mm	8 mm, e.g. fischer S8, Type No.: 50108
ANT D10 antenna	5 x 40 mm	8 mm, e.g. fischer S8, Type No.: 50108

¹⁾ Represents minimum length

 WARNING
Ensure that the wall or ceiling can hold four times the total weight of the device.

4.3.3 Metal-free area

The metal-free area for the MDS

Direct mounting of the MDS on metal or flush-mounting in metal is **not permitted**. If the MDS is directly mounted onto metal, all functions of the MDS will be disabled.

The minimum distance between the MDS and metal is shown in the appropriate sections "Metal-free area" of the chapter Mobile data storage units (Page 95).

The metal-free area for the SLG D12/SLG D12S

When mounting the SLG, it is important to note that metal in the vicinity of the antennas can affect the field data.

ANT D5

ANT D5 must be mounted electrically isolated, direct mounting on metal is **not permitted**.

The maximum field data (no interference = 100 %) are achieved when the antenna ANT D5 is mounted at a distance of 100 mm from metal (spacer kit 6GT2690-0AB00).

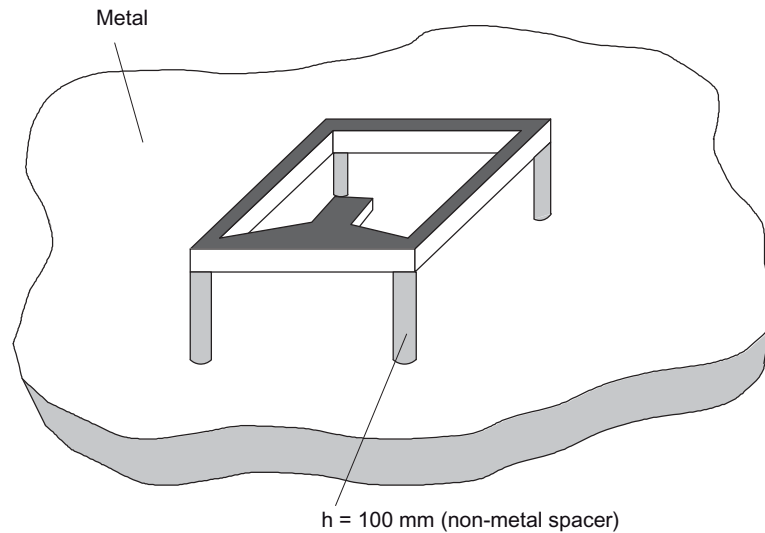

Figure 4-9 ANT D5: Insulated mounting on metal

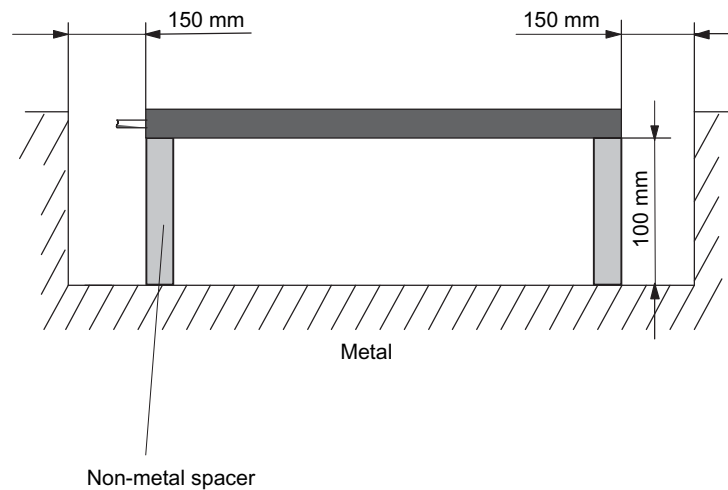

Figure 4-10 ANT D5: Installation in metal

See also Subsection *Influencing the transmission window*.

ANT D6/D10

Mounting on metal permitted. Typical distances from metal are indicated in the section *Metal-free area* in the chapter *write/read devices*.

SLG D12/SLG D12S

With SLG D12/SLG D12S with integral antenna, the height of the housing provides sufficient distance from the metal base; the device can be mounted directly onto metal. In the case of flush-mounting, you must however comply with the specified lateral distance to metal.

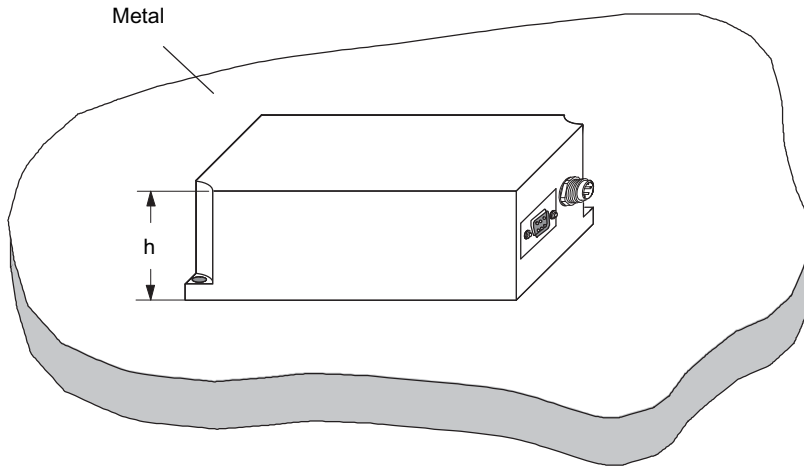

h = Height of the SLG = 40 mm

Figure 4-11 Mounting on metal: SLG D12/SLG D12S

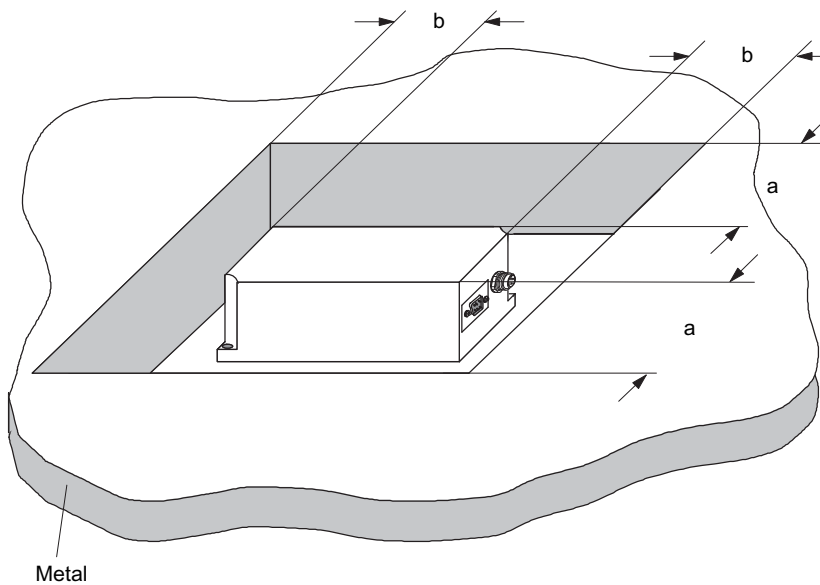

a, b = Metal free distances = 50 mm

Figure 4-12 Flush-mounting in metal: SLG D12/SLG D12S

4.3.4 Influences affecting the transmission window

In general, the following points should be considered when mounting MOBY D components:

- Flush-mounting of components in metal reduces the field data.
- When working inside the transmission window, it should be ensured that no metal rails or closed conductor loops protrude into the transmission field. They would impair the field profile.
- It is recommended that a test is performed in critical applications.
- In order to ensure optimum field data even in the vicinity of metal, ANT D5 is calibrated at the factory at a distance of 100 mm from metal (see the following tables). Therefore it must always be operated at a distance of 100 mm from metal.

The impact of metal on the field data (Sg, Sa, Lx, Ly) is shown in tabular and graphical format in this section.

The values in the tables describe field data reduction as a percentage (100% means no impact).

SLG D12/D12S

Table 4- 15 Reduction of field data by metal (in %): MDS and SLG D12/D12S

Transponder		SLG D12/D12S		
		Without metal	On metal	Flush-mounted In metal (50 mm all- round)
MDS D100	Without metal	100	80	70
	On metal; distance 20 mm	70	70	60
	Flush-mounted in metal; distance all-round 20 mm	65	55	55
MDS D124	Without metal	100	80	70
	On metal; distance 25 mm	80	65	55
	Flush-mounted in metal; distance all-round 25 mm	65	55	50
MDS D139	Without metal	100	65	65
	On metal; distance 30 mm	90	65	65
MDS D160	Without metal	100	80	80
	On metal; distance 25 mm	100	80	80
MDS D324	Without metal	100	80	70
	On metal; distance 25 mm	80	65	55
	Flush-mounted in metal; distance all-round 25 mm	65	55	50
MDS D424	Without metal	100	80	70
	On metal; distance 25 mm	80	65	55
	Flush-mounted in metal; distance all-round 25 mm	65	55	50
MDS D428	Without metal	100	80	80
	On metal	80	70	70
MDS D460	Without metal	100	80	80
	On metal; distance 25 mm	80	70	70
MDS D200	Without metal	100	80	70
	On metal; distance 20 mm	70	70	60
	Flush-mounted in metal; distance all-round 20 mm	65	55	55

SLG D11/D11S with ANT D5

Table 4- 16 Reduction of field data by metal (in %): MDS and SLG D11/D11S with ANT D5

Transponder		SLG D11/D11S with ANT D5	
		On metal 100 mm distance	Flush-mounted in metal 100 mm distance (150 mm all-round)
MDS D100	Without metal	100	95
	On metal; distance 20 mm	60	55
	Flush-mounted in metal; distance all-round 20 mm	45	40
MDS D124	Without metal	100	95
	On metal, distance 25 mm	60	55
	Flush-mounted in metal; distance all-round 25 mm	40	35
MDS D139	Without metal	100	95
	On metal, distance 30 mm	80	75
MDS D160 ¹⁾	Without metal	100	90
	On metal; distance 25 mm	55	50
	Flush-mounted in metal; distance all-round 25 mm	--	--
MDS D324	Without metal	100	95
	On metal; distance 25 mm	60	55
	Flush-mounted in metal; distance all-round 25 mm	40	35
MDS D424	Without metal	100	95
	On metal; distance 25 mm	60	55
	Flush-mounted in metal; distance all-round 25 mm	40	35
MDS D428	Without metal	100	95
	On metal	40	35
MDS D460	Without metal	100	95
	On metal; distance 25 mm	40	35
MDS D200	Without metal	100	95
	On metal; distance 20 mm	60	55
	Flush-mounted in metal; distance all-round 20 mm	45	40

¹⁾ Values apply to metal surfaces greater than 100 mm x 100 mm

SLG D10/D10S with ANT D5

Table 4- 17 Reduction of field data by metal (in %): MDS and SLG D10/D10S with ANT D5

Transponder		SLG D10/D10S with ANT D5	
		On metal	Flush-mounted in metal (150 mm all-round)
MDS D100	Without metal	100	95
	On metal; distance 20 mm	65	60
	Flush-mounted in metal; distance all-round 20 mm	45	40
MDS D124	Without metal	100	95
	On metal; distance 25 mm	85	80
	Flush-mounted in metal; distance all-round 25 mm	65	60
MDS D139	Without metal	100	95
	On metal, distance 30 mm	90	85
MDS D160 ¹⁾	Without metal	100	95
	On metal; distance 25 mm	70	65
	Flush-mounted in metal; distance all-round 25 mm	25	20
MDS D324	Without metal	100	95
	On metal; distance 25 mm	75	70
	Flush-mounted in metal; distance all-round 25 mm	--	--
MDS D424	Without metal	100	95
	On metal; distance 25 mm	75	70
	Flush-mounted in metal; distance all-round 25 mm	--	--
MDS D428	Without metal	100	95
	On metal	--	--
MDS D460	Without metal	100	95
	On metal; distance 25 mm	--	--
MDS D200	Without metal	100	95
	On metal; distance 20 mm	65	60
	Flush-mounted in metal; distance all-round 20 mm	--	--

¹⁾ Values apply to metal surfaces greater than 100 mm x 100 mm

SLG D10/D10S with ANT D6

Table 4- 18 Reduction of field data by metal (in %): MDS and SLG D10/D10S with ANT D6

Transponder		SLG D10/D10S with ANT D6	
		On metal	Flush-mounted in metal (200 mm all-round)
MDS D100	Without metal	100	95
	On metal; distance 20 mm	65	60
	Flush-mounted in metal; distance all-round 20 mm	--	--
MDS D124	Without metal	100	95
	On metal, distance 25 mm	80	75
	Flush-mounted in metal; distance all-round 25 mm	--	--
MDS D139	Without metal	100	90
	On metal, distance 30 mm	80	70
MDS D160 ¹⁾	Without metal	100	90
	On metal; distance 25 mm	60	55
	Flush-mounted in metal; distance all-round 25 mm	--	--
MDS D324	Without metal	100	95
	On metal; distance 25 mm	75	70
	Flush-mounted in metal; distance all-round 25 mm	--	--
MDS D424	Without metal	100	95
	On metal; distance 25 mm	75	70
	Flush-mounted in metal; distance all-round 25 mm	--	--
MDS D428	Without metal	100	95
	On metal	70	65
MDS D460	Without metal	100	95
	On metal	70	65
MDS D200	Without metal	100	95
	On metal; distance 20 mm	65	60
	Flush-mounted in metal; distance all-round 20 mm	--	--

¹⁾ Values apply to metal surfaces greater than 100 mm x 100 mm

SLG D10/D10S with ANT D10

Table 4- 19 Reduction of field data by metal (in %): MDS and SLG D10/D10S with ANT D10

Transponder		SLG D10/D10S with ANT D10	
		On metal	Flush-mounted in metal (200 mm all-round)
MDS D100	Without metal	100	90
	On metal; distance 20 mm	50	40
	Flush-mounted in metal; distance all-round 20 mm	--	--
MDS D124	Without metal	100	90
	On metal, distance 25 mm	70	60
	Flush-mounted in metal; distance all-round 25 mm	--	--
MDS D139	Without metal	100	90
	On metal, distance 30 mm	80	70
MDS D160 ¹⁾	Without metal	100	90
	On metal; distance 25 mm	65	55
	Flush-mounted in metal; distance all-round 25 mm	--	--
MDS D324	Without metal	100	90
	On metal; distance 25 mm	70	60
	Flush-mounted in metal; distance all-round 25 mm	--	--
MDS D424	Without metal	100	90
	On metal; distance 25 mm	70	60
	Flush-mounted in metal; distance all-round 25 mm	--	--
MDS D428	Without metal	100	90
	On metal	50	40
MDS D460	Without metal	100	90
	On metal; distance 25 mm	50	40
MDS D200	Without metal	100	90
	On metal; distance 20 mm	50	40
	Flush-mounted in metal; distance all-round 20 mm	--	--

¹⁾ Values apply to metal surfaces greater than 100 mm x 100 mm

Note

The values specified in the tables must be complied with. The inductive fields may be affected if the distance is smaller. In this case, the data transfer time would increase unpredictably or a command would be aborted with an error.

If the distance is smaller, it is recommended that a test is performed.

From the following diagrams, you can see the impact on the transmission window based on the example of SLG D10 ANT D5 with MDS D139.

The percentages describe the reduction in field data for ANT D5 and MDS in a metal environment (100% corresponds to no impact).

4.3.4.1 MDS in metal-free environment

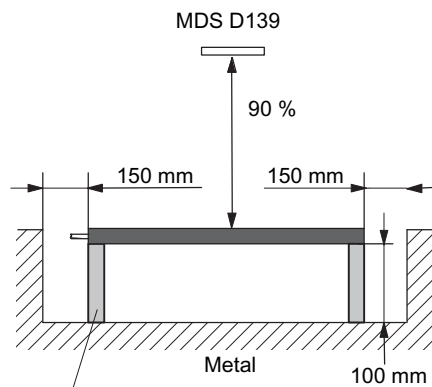
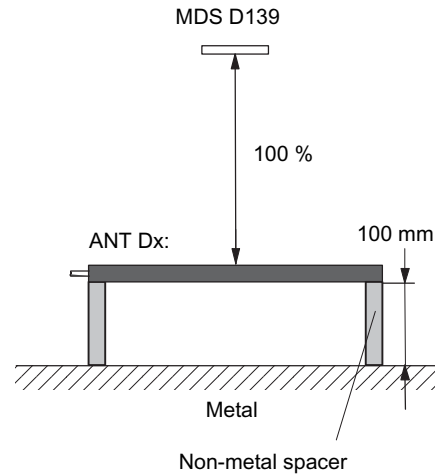

Non-metal spacer

Figure 4-13 MDS in metal-free environment

4.3.4.2 MDS in the vicinity of metal

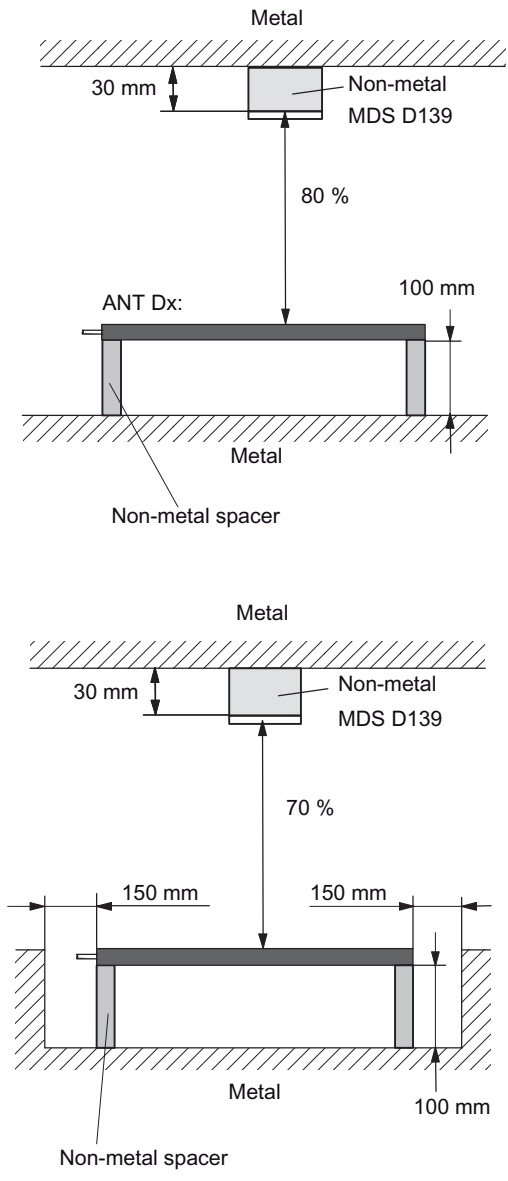
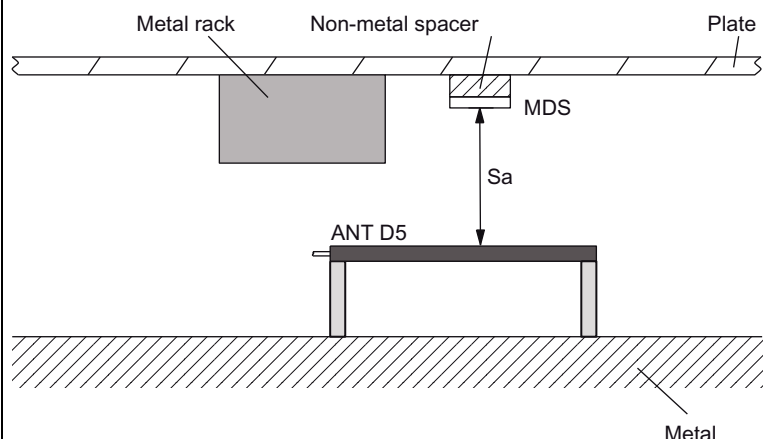
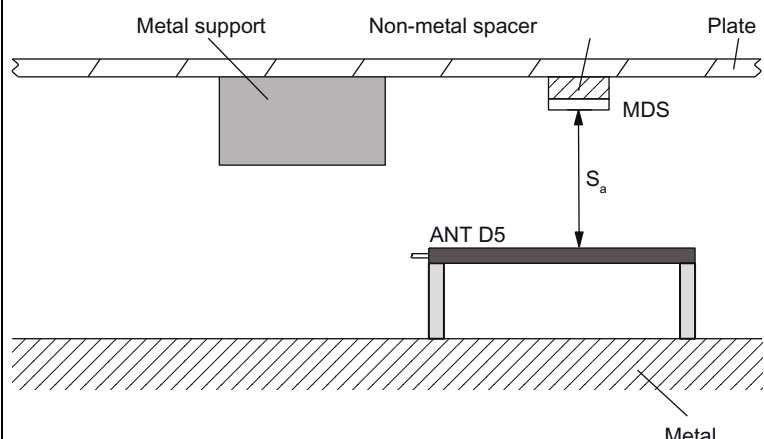

Figure 4-14 MDS in the vicinity of metal

4.3.5 Reduction of interference due to metal

Interference due to metal rack

Interference due to metal rack	Problem
 <p>The diagram illustrates a cross-section of a metal rack assembly. A horizontal plate is supported by a metal rack. A non-metal spacer is placed between the plate and the antenna (ANT D5). The distance between the antenna and the spacer is labeled S_a. The MDS (Metal Detection System) is located between the spacer and the antenna. The entire assembly is mounted on a metal base.</p>	<p>A metal rack is located above the transmission window of ANT D5. This affects the entire field. In particular, the transmission window between ANT Dx and the MDS is reduced.</p>
 <p>The diagram illustrates a cross-section of a metal support assembly. A horizontal plate is supported by a metal support. A non-metal spacer is placed between the plate and the antenna (ANT D5). The distance between the antenna and the spacer is labeled S_a. The MDS (Metal Detection System) is located between the spacer and the antenna. The entire assembly is mounted on a metal base.</p>	<p>Remedy: The transmission window is no longer affected if ANT Dx is mounted differently.</p>

Flush-mounting

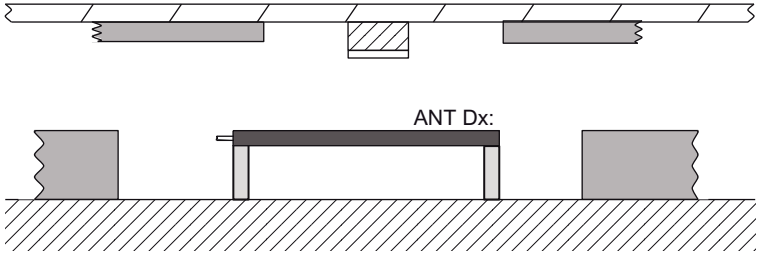
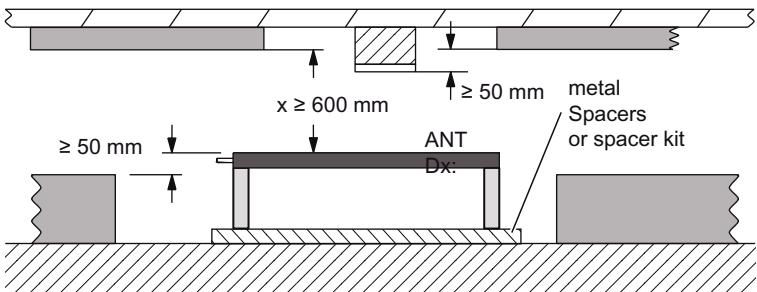
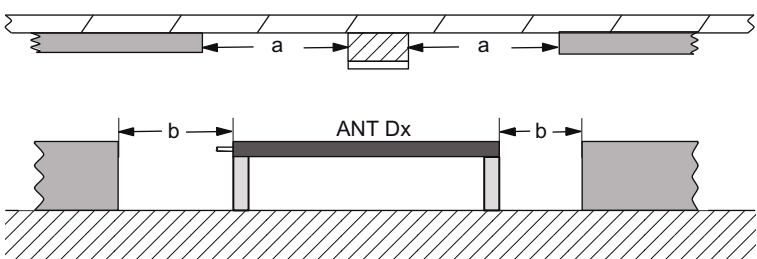
Flush-mounting	Problem
	<p>Flush-mounting of MDS and SLG / ANT Dx is possible in principle. However, the size of the transmission window is significantly reduced. The following measures can be used to counteract the reduction of the window:</p>
	<p>Remedy:</p> <p>Replace the non-metal spacer below the MDS with a larger one. MDS and/or SLG / ANT Dx must be at least 50 mm higher than the surrounding metal. (At a distance $x \geq 600$ mm from metal, the field is no longer noticeably affected.)</p>
	<p>Remedy:</p> <p>Increase the non-metal distances a and b. As a rule of thumb:</p> <ul style="list-style-type: none"> • Select values for a and b that are larger by a factor of 2 to 3 • Increasing a and b has a greater effect for antennas/MDS with a large limit distance than for antennas/MDS with a small limit distance.

4.3.6 Mounting of multiple antennas on or between metal frames

Mounting of multiple antennas on or between metal frames

If closed conductor loops (metal frames, guides with cross struts) are located within the area of the antenna's magnetic field, some of the energy will be coupled into these.

This effect results in:

- non-configurable field geometries
- undesired field propagation ("transformer effect")

The undesired field propagation would interfere with other antennas in the reception field or reach other MDSs outside the configured fields.

To prevent these effects, care must be taken to avoid closed conductor loops in the transmission range of the antennas or to interrupt them non-metallically.

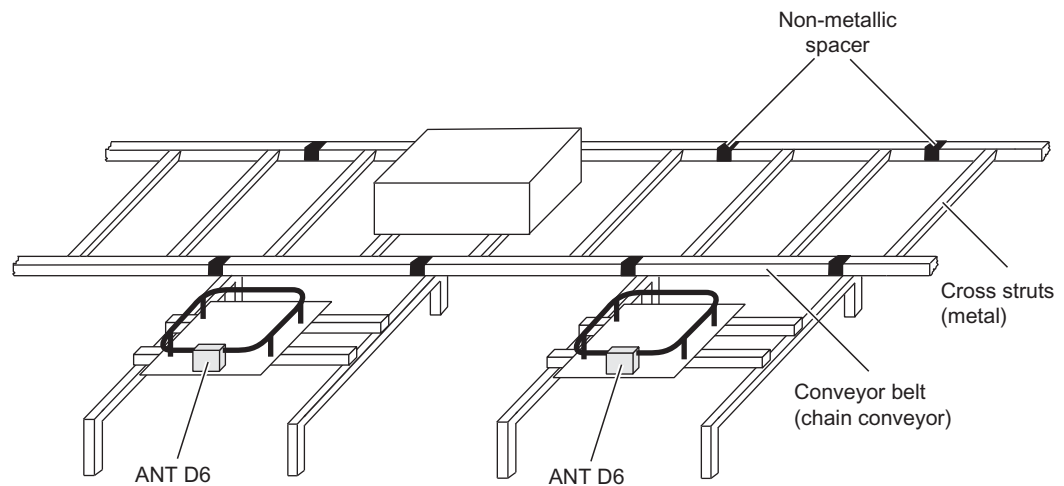

Figure 4-15 Conveyors/metal frames with non-metallic spacers

4.3.7 Installation and interconnection of 2, 3 or 4 MOBY D antennas to one SLG D10/D10S write/read device.

Possible configurations of the antennas

The antenna installations described here have been designed for reading smartlabels (transponders) on goods on conveyor belts, conveyor systems or pallets.

A prerequisite is that there are no magnetically conducting materials (e.g. metal) in the vicinity of the antenna or the label.

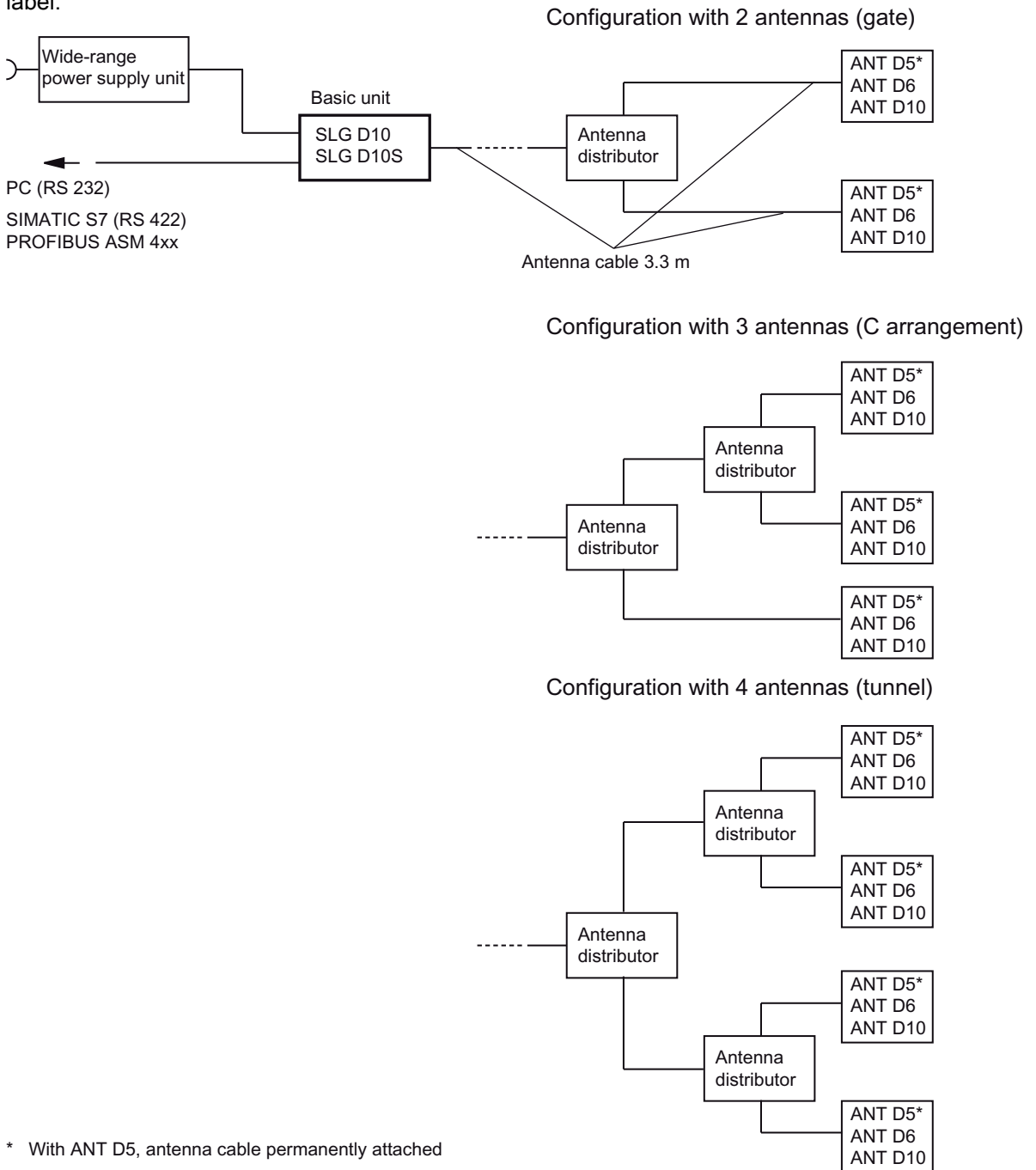

Figure 4-16 Possible configuration of SLG D10/D10S with ANT D5/D6/D10

Installation examples

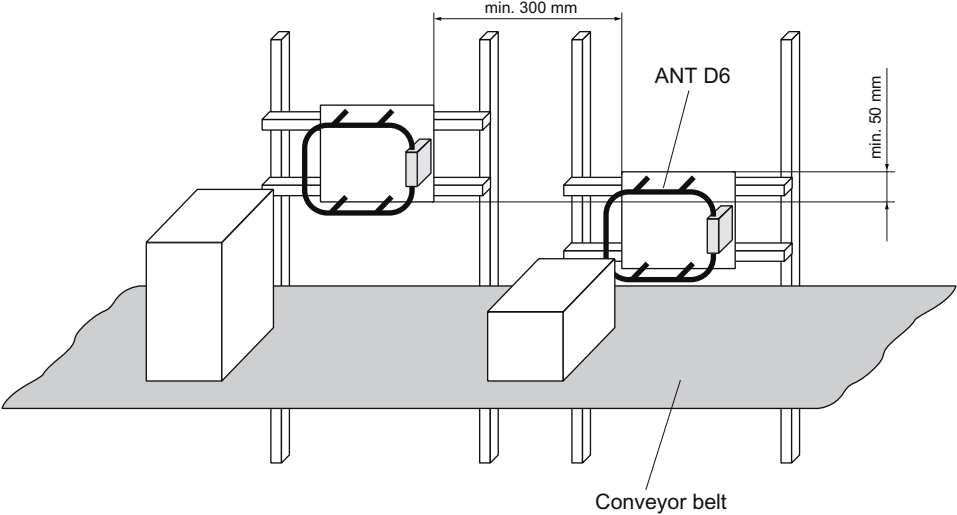

Figure 4-17 Installation example with 2 ANT D6 (portal)

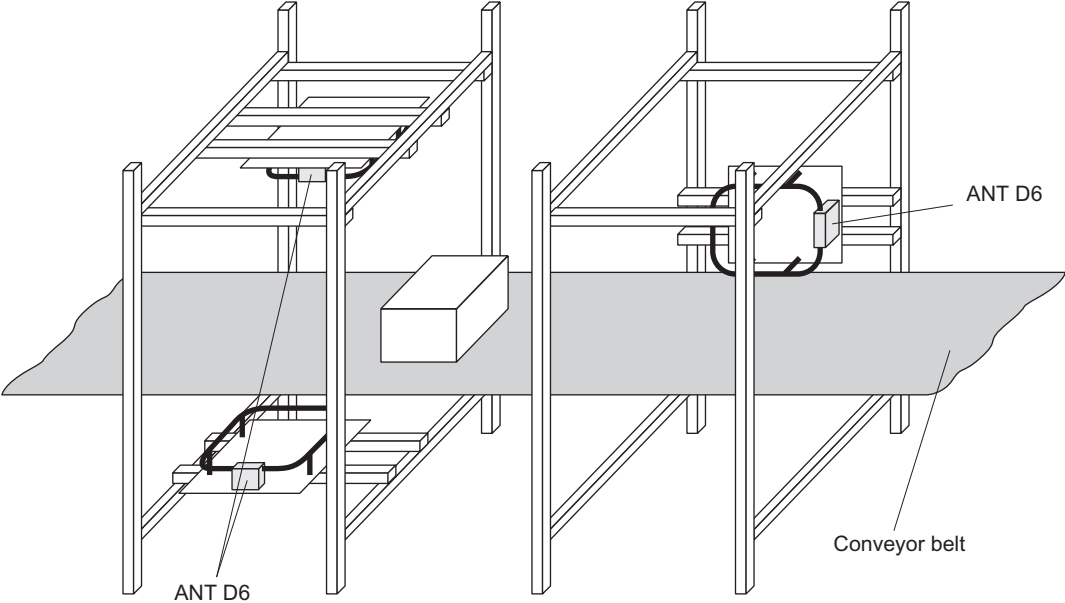

Figure 4-18 Installation example with ANT D6 (C arrangement)

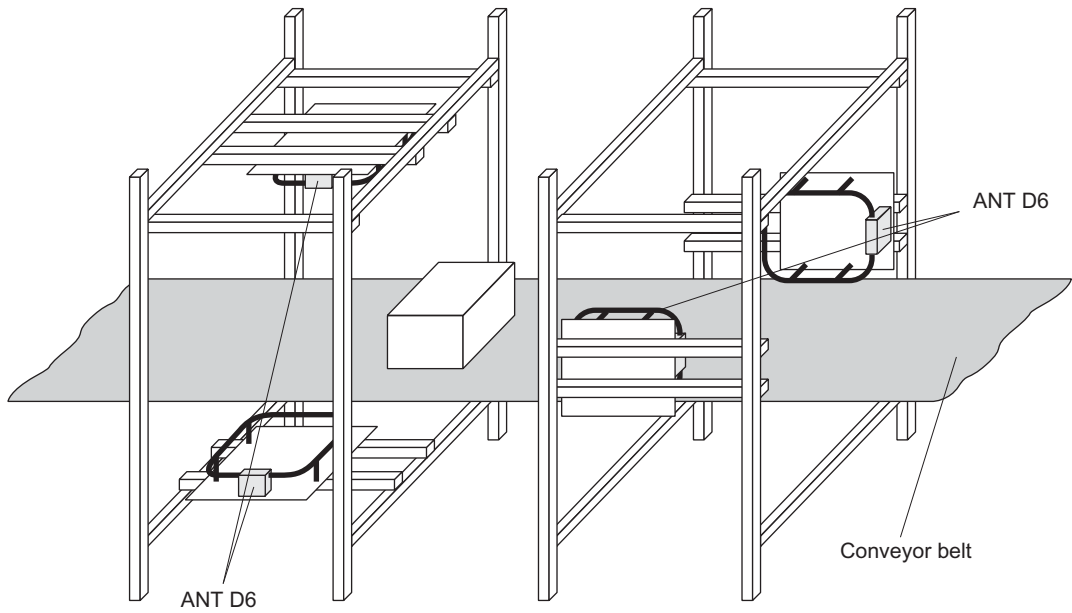

Figure 4-19 Installation example with ANT D6 (tunnel)

Note

The minimum spacings between the antennas for operation with only one reader may be less than the distances described because this configuration has the same phase.

Configuring instructions

The antenna installation described below enables detection of transponders moving horizontally through the installation. Depending on the installation (antennas exactly opposite each other or offset in parallel), the label is aligned in parallel with the antennas or arbitrarily. The size of the sensing range depends on the label alignment:

NOTICE

It must be noted that the overall sensing range of the antennas is greater than the sensing range to be configured. This means there can be label alignments where even labels outside the sensing range will be detected. Labels aligned in parallel with the antennas, for example, can also be detected at larger distances beside or outside the antenna range.

For this reason, goods with labels must not be stored within a distance of up to 0.5 m from the installation. If this cannot be complied with, the antennas must be shielded.

To achieve three-dimensional detection of the labels in the sensing range, the following requirements must be met:

- The gate width must be less than or equal to 800 mm.
- The antenna size of the labels must be at least the size of an ISO card (85 mm x 54 mm).
- The distance from label to label must be greater than 100 mm. The distance from label to label can be reduced if the gate width is correspondingly reduced. This applies especially for distances under 50 mm
- There must be no more than 16 labels within the sensing range of the antennas at the same time.
The number of labels can be increased if the gate width is correspondingly reduced and the maximum speed appropriately adapted.
- The maximum speed of the labels must not exceed 1 m/s. (This depends on the number and alignment of the labels, the number of data blocks to be processed, the data protocol required and the label type).
- To the front and sides of the antenna, there must be a distance of more than 150 mm to metal parts.
- There must be no interference to the write/read device from other electrical equipment in the surrounding area.

Note

The SLG D10S is not multitag-enabled.

Components required

For installation with

- 2 antennas (gate)
- 3 antennas (C arrangement)
- 4 antennas (tunnel)

the following components are required:

4.3 Installation guidelines

Number for installation with			Component	Order No.
2 ant.	3 ant.	4 ant.		
1	1	1	Basic unit: SLG D10 (↔ PC) SLG D10S ↔ ASM 4xx/RF1xx)	SLG D10S: 6GT2698-1AA00 SLG D10S: 6GT2698-2AA00 optionally: ASM 452: 6GT2002-0EB20 ASM 473: 6GT2002-0HA10 ASM 475: 6GT2002-0GA10 ASM 456: 6GT2002-0ED00 RF170C: 6GT2002-0HD00/ 6GT2002-1HD00 RF180C: 6GT2002-0JD00 RF182C: 6GT2002-0JD10
2	3	4	Antenna ANT D5 / D6 / D10	optionally: ANT D5: 6GT2698-5AA00 ANT D6: 6GT2698-5AB00 ANT D10: 6GT2698-5AF00
2	3	4	With ANT D5 if required: spacer kit for ANT D5	6GT2690-0AB00
2	3	4	With ANT D6 if required: cover	6GT2698-5AD00
1	2	3	Antenna duplexer	6GT2603-0AC00
1	1	1	MOBY wide-range power supply unit for SIMATIC RF systems	EU: 6GT2898-0AA00 UK: 6GT2898-0AA10 US: 6GT2898-0AA20
1	1	1	24 V connecting cable, 5 m in length	6GT2491-1HH50
1	1	1	Connecting cable: SLG D10 ↔ PC or SLG D10S ↔ ASM 4xx/RF1xx	6GT2691-0B ... optionally: 6GT2491-0E ... 6GT2491-1C ... 6GT2691-0F ... 6GT2691-0FH20

Installation information

The cables on the antennas and the antenna duplexer are 3.3 m or 10.5 m long respectively. The write/read device must be installed in the vicinity of the antennas. In the case of larger distances between the write/read device and the antennas, the antenna cable can be increased by 7.2 m with the extension (6GT2 691-0DH72). This results in shorter ranges.

Metal-free area

To guarantee perfect functioning of the individual installation versions, all larger metal parts in the vicinity of the antennas must be removed.

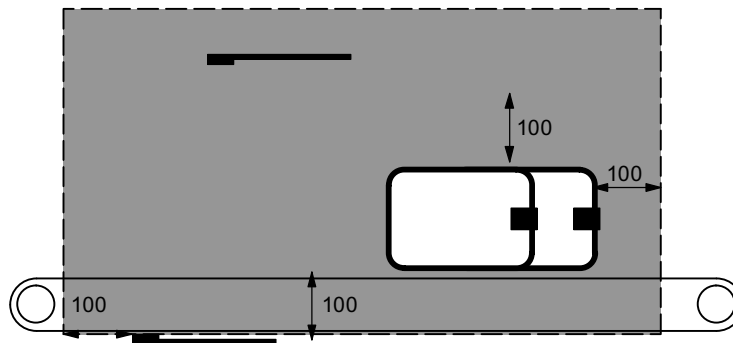

Figure 4-20 Metal-free space _side view (using the example of tunnel arrangement on a conveyor belt)

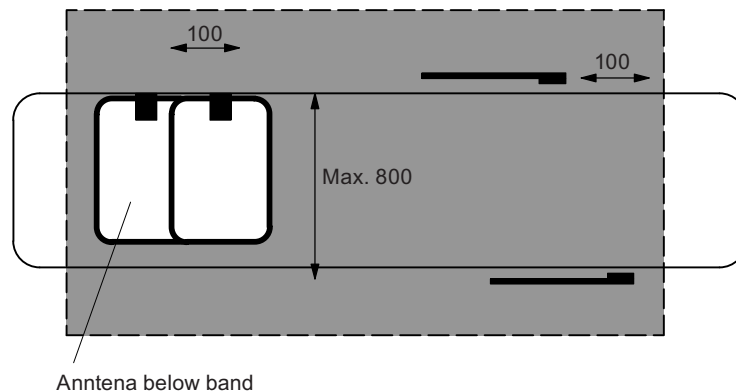

Figure 4-21 Metal-free space _plan view (using the example of tunnel arrangement on a conveyor belt)

Metal in the vicinity of the antennas

If metal in the vicinity of the antennas cannot be avoided, the following must be noted:

- There must be a minimum allround gap of 100 mm between the antenna and metal. Serious loss of sensing range must be expected above 50 mm. There is no discernible influence at distances greater than 150 mm from the metal.
- The influence of the metal depends heavily on its size and shape. Thin metal rods have less influence on the magnetic field than large surfaces.
- Larger metal surfaces (edge length > 50 mm) in parallel with the antennas or labels result in a short-circuit of the magnetic lines of force. As a result, the labels cannot be read.
- Metal parts under the conveyor belt change the direction of the magnetic lines of force. Serious loss of sensing range must be expected as a result. Horizontally aligned labels cannot be read in such cases.
- **The metal parts must not form closed loops or circuits. If necessary, these must be electrically interrupted at one point.**

- The metal parts in the immediate vicinity of the antenna must be grounded in a mesh with a good HF connection.
- Since the write/read device is installed in a metal housing, and the antennas can couple into the cables to the write/read device, it must be installed at a distance of at least 500 mm from the antennas.

Notes on installing and laying the antenna cable

To suppress possible interference, an EMC hinged ferrite choke must be fitted to the antenna cables (as well as the antenna cable between the SLG and the antenna duplexer). The coaxial cable must be wound tightly at least four times through the EMC ring core. The maximum distance between the connecting plug for the write/read device or the antenna duplexer and the ring core must be 100 mm.

The antenna cable must always be run vertically from the antennas. A minimum distance of 200 mm to the antennas must be observed with further cable routing. Otherwise, performance losses must be expected.

There must be a distance of at least 300 mm between antenna cables and parallel power cables.

Unrequired cable length must be secured in a bundle with a diameter of 100 to 150 mm.

If the standard antenna cable is too short, it can be increased by 7.20 m with the extension. Slight range losses must be expected here.

To achieve optimal read ranges, the antenna cable should not be shortened or lengthened.

4.4 Chemical resistance of the MDS

MDS D100 (6GT2600-0AD10)

The enclosure of the MDS D100 is made of PC (polycarbonate).

MDS D100 is resistant to the substances specified in the following table.

Table 4- 20 Chemical resistance of MDS D100

Substance	Evaluation
Acetone	□
Alcohol	▣
Aliphatic hydrocarbons	■
Aromatic hydrocarbons	□
Hot water (hydrolysis resistance)	□
Mineral lubricants	▣
Oxidizing acids	□
Perchloroethylene	□
Petroleum spirit	□
Strong alkalis	□
Strong mineral acids	▣
Strong organic acids	▣
Trichloroethylene	□
Weak alkalis	□
Weak mineral acids	■
Weak organic acids	■
Abbreviations:	
■	Resistant
▣	Limited resistance
□	Not resistant

**MDS D100 (6GT2600-0AD00) and
MDS D200**

The enclosure of the MDS is made of PVC.

The MDS are resistant to the substances specified in the following table.

Table 4- 21 Chemical resistance of MDS D100/D200

Substance	Concentration
Acetic acid, aqueous solution	5%
Ethanol, aqueous solution	60%
Ethylene glycol	50%
Fuel B	according to ISO 1817
Human sweat	
Saline solution	5%
Sodium carbonate, aqueous solution	5%
Sugared water	10%

(Reference: ISO 10373 / ISO 7810)

MDS D139 (6GT2600-0AA10)
MDS D124 (6GT2600-0AC10)
MDS D160 (6GT2600-0AB10)

The housing of the heat-resistant data storage unit MDS D139 is made of polyphenylene sulfide (PPS). The chemical resistance of the data storage unit is excellent. No solvent is known that can dissolve the plastic at temperatures below 200 °C. A reduction in the mechanical properties has been observed in aqueous solutions of hydrochloric acid (HCl) and nitric acid (HNO₃) at 80 °C.

The excellent resistance to all fuel types including methanol is a particular characteristic. The following table provides an overview of the chemicals investigated.

Table 4- 22 Chemical resistance of MDS D139, MDS D124, MDS D160

Substance	Test conditions		Evaluation
	Time [days]	Temperature [°C]	
(FAM-DIN 51604-A) Toluol	180	80	/
1, 1, 1-trichloroethane xylene	180	80	+
Acetone	180	55	+
Anti-freeze	180	120	+
Brake fluid	40	80	+
Butanon-2 (methyl ethyl ketone)	180	60	+
Calcium chloride (saturated)	40	80	+
Caustic soda (30 percent)	40	93	+
Diesel fuel	180	80	+
Diethyl ether	40	23	+
Engine oil	40	80	+
Frigen 113	40	23	+
Hydrochloric acid (10 percent)	40	80	-
Kerosine	40	60	+
Methanol	180	60	+
n-Butanol (butyl alcohol)	180	80	+
n-butyl acetate	180	80	+
Nitric acid (10 percent)	40	23	+
Sodium chloride (saturated)	40	80	+
Sodium hydroxide (30 percent)	180	80	+
Sodium hypochlorite (5 percent)	30 180	80 80	/ -
Sulphuric acid (10 percent)	40	23	+
(10 percent)	40	80	/
(30 percent)	40	23	+

Substance	Test conditions		Evaluation
	Time [days]	Temperature [°C]	
Tested fuels:	40	80	+
Zinc chloride (saturated)	180	80	/
	180	75	+
	180	80	+
	40	80	+
Assessment:			
+	Resistant, weight gain < 3 % or weight loss < 0.5 % and/or reduction in fracture resistance < 15 %		
/	Limited resistance, weight gain 3 to 8 % or weight loss 0.5 to 3 % and/or reduction in fracture resistance 15 to 30 %		
-	Not resistant, weight gain > 8 % or weight loss > 3 % and/or reduction in fracture resistance > 30 %		

MDS D124 (6GT2600-0AC00)
MDS D324
MDS D424
MDS D460

The enclosure of the MDS is made of epoxy resin. The following table provides an overview of the chemical resistance.

Table 4- 23 Chemical resistance of MDS D124, MDS D324, MDS D424, MDS D460

Chemical compound	Concentration	20 °C	40 °C	60 °C
Acetic acid	100 %	■		
Ammonia liquid, water-free		□		
Benzol, benzoic acid		■		
Borax				■
Boric acid		■		
Brine				□
Bromine, liquid, bromine water		□		
Butyric acid	100 %	■		
Carbonate (ammonium, sodium, etc.)				■
Chlorine water (saturated solution)		■		
Chlorine, liquid		□		
Chlorobenzene		■		
Chloroform		□		
Chromate (potassium, sodium, etc.)	Up to 50%		■	
Chromic acid	Up to 30 %	□		
Citric acid		■		
Cyanide (potassium, sodium, etc.)				■
Diethylene glycol				■
Dioxane		□		
Ethanol			■	■
Fixer			■	
Fluoride (ammonium, potassium, sodium, etc.)			■	
Formaldehyde	50 %	■		
Formic acid	50 %	■		
Gasoline, aromatic-free/containing benzol		■		
Glycerine				■
Glycol				■
Hydrochloric acid, nitric acid	10 %	□		
Hydrofluoric acid	Up to 40 %	■		
Hydrogen peroxide	30 %	■		
Hydroxide (sodium, potassium)	40 %	■		
Iodide (potassium, sodium, etc.)				■
Lactic acid	100 %	■		
Methanol	100 %		■	
Mineral oils			■	

4.4 Chemical resistance of the MDS

Chemical compound	Concentration	20 °C	40 °C	60 °C
Nitrate (ammonium, potassium, etc.)				■
Nitroglycerine		□		
Phosphate (ammonium, sodium, etc.)				■
Phosphoric acid	50 %			■
Propanol		■		
Silicic acid				■
Soap solution				■
Sulfide (ammonium, sodium, etc.)				□
Sulphate (ammonium, sodium, etc.)				■
Sulphur dioxide	100 %	■		
Sulphuric acid	40 %	□		
Tartaric acid		■		
Trichloroethylene		□		
Turpentine		■		
Urine, uric acid		■		
Abbreviations:				
■	Resistant			
■	Limited resistance			
□	Not resistant			

MDS D428

The enclosure of the MDS D428 comprises:
the hood: PA6.6 GF30
the screw: Stainless steel

The MDS D428 is resistant to the substances specified in the following table.

Table 4- 24 Chemical resistance of MDS D428

Substance	Concentration
Acetone	■
Alcohol	■
Aliphatic hydrocarbons	■
Aromatic hydrocarbons	■
Hot water (hydrolysis resistance)	☑
Mineral lubricants	■
Oxidizing acids	□
Perchloroethylene	■
Petroleum spirit	■
Strong alkalis	□
Strong mineral acids	□
Strong organic acids	□
Trichloroethylene	■
Weak alkalis	☑
Weak mineral acids	☑
Weak organic acids	☑
Abbreviations:	
■	Resistant
☑	Limited resistance
□	Not resistant

4.5 EMC Guidelines

4.5.1 Overview

These EMC Guidelines answer the following questions:

- Why are EMC guidelines necessary?
- What types of external interference have an impact on the system?
- How can interference be prevented?
- How can interference be eliminated?
- Which standards relate to EMC?
- Examples of interference-free plant design

The description is intended for "qualified personnel":

- Project engineers and planners who plan system configurations with RFID modules and have to observe the necessary guidelines.
- Fitters and service engineers who install the connecting cables in accordance with this description or who rectify defects in this area in the event of interference.

NOTICE
Failure to observe notices drawn to the reader's attention can result in dangerous conditions in the plant or the destruction of individual components or the entire plant.

4.5.2 What does EMC mean?

The increasing use of electrical and electronic devices is accompanied by:

- Higher component density
- More switched power electronics
- Increasing switching rates
- Lower power consumption of components due to steeper switching edges

The higher the degree of automation, the greater the risk of interaction between devices.

Electromagnetic compatibility (EMC) is the ability of an electrical or electronic device to operate satisfactorily in an electromagnetic environment without affecting or interfering with the environment over and above certain limits.

EMC can be broken down into three different areas:

- Intrinsic immunity to interference:
immunity to internal electrical disturbance
- Immunity to external interference:
immunity to external electromagnetic disturbance
- Degree of interference emission:
emission of interference and its effect on the electrical environment

All three areas are considered when testing an electrical device.

The RFID modules are tested for conformity with the limit values required by the CE and RTTE guidelines. Since the RFID modules are merely components of an overall system, and sources of interference can arise as a result of combining different components, certain guidelines have to be followed when setting up a plant.

EMC measures usually consist of a complete package of measures, all of which need to be implemented in order to ensure that the plant is immune to interference.

Note

The plant manufacturer is responsible for the observance of the EMC guidelines; the plant operator is responsible for radio interference suppression in the overall plant.

All measures taken when setting up the plant prevent expensive retrospective modifications and interference suppression measures.

The plant operator must comply with the locally applicable laws and regulations. They are not covered in this document.

4.5.3 Basic rules

It is often sufficient to follow a few elementary rules in order to ensure electromagnetic compatibility (EMC).

The following rules must be observed:

Shielding by enclosure

- Protect the device against external interference by installing it in a cabinet or housing. The housing or enclosure must be connected to the chassis ground.
- Use metal plates to shield against electromagnetic fields generated by inductances.
- Use metal connector housings to shield data conductors.

Wide-area ground connection

- Plan a meshed grounding concept.
- Bond all passive metal parts to chassis ground, ensuring large-area and low-HF-impedance contact.
- Establish a large-area connection between the passive metal parts and the central grounding point.
- Don't forget to include the shielding bus in the chassis ground system. That means the actual shielding busbars must be connected to ground by large-area contact.
- Aluminium parts are not suitable for ground connections.

Plan the cable installation

- Break the cabling down into cable groups and install these separately.
- Always route power cables, signal cables and HF cables through separated ducts or in separate bundles.
- Feed the cabling into the cabinet from one side only and, if possible, on one level only.
- Route the signal cables as close as possible to chassis surfaces.
- Twist the feed and return conductors of separately installed cables.
- Routing HF cables:
avoid parallel routing of HF cables.
- Do not route cables through the antenna field.

Shielding for the cables

- Shield the data cables and connect the shield at both ends.
- Shield the analog cables and connect the shield at one end, e.g. on the drive unit.
- Always apply large-area connections between the cable shields and the shielding bus at the cabinet inlet and make the contact with clamps.
- Feed the connected shield through to the module without interruption.
- Use braided shields, not foil shields.

Line and signal filter

- Use only line filters with metal housings
- Connect the filter housing to the cabinet chassis using a large-area low-HF-impedance connection.
- Never fix the filter housing to a painted surface.
- Fix the filter at the control cabinet inlet or in the direction of the source.

4.5.4 Propagation of electromagnetic interference

Three components have to be present for interference to occur in a system:

- Interference source
- Coupling path
- Interference sink

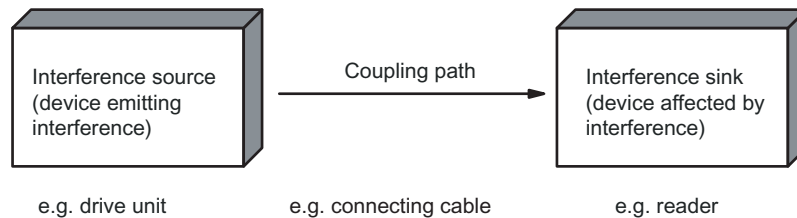

Figure 4-22 Propagation of interference

If one of the components is missing, e.g. the coupling path between the interference source and the interference sink, the interference sink is unaffected, even if the interference source is transmitting a high level of noise.

The EMC measures are applied to all three components, in order to prevent malfunctions due to interference. When setting up a plant, the manufacturer must take all possible measures in order to prevent the occurrence of interference sources:

- Only devices fulfilling limit class A of VDE 0871 may be used in a plant.
- Interference suppression measures must be introduced on all interference-emitting devices. This includes all coils and windings.
- The design of the system must be such that mutual interference between individual components is precluded or kept as small as possible.

Information and tips for plant design are given in the following sections.

Interference sources

In order to achieve a high level of electromagnetic compatibility and thus a very low level of disturbance in a plant, it is necessary to recognize the most frequent interference sources. These must then be eliminated by appropriate measures.

Table 4- 25 Interference sources: origin and effect

Interference source	Interference results from	Effect on the interference sink
Contactors, electronic valves	Contacts	System disturbances
	Coils	Magnetic field
Electrical motor	Collector	Electrical field
	Winding	Magnetic field
Electric welding device	Contacts	Electrical field
	Transformer	Magnetic field, system disturbance, transient currents
Power supply unit, switched-mode	Circuit	Electrical and magnetic field, system disturbance
High-frequency appliances	Circuit	Electromagnetic field
Transmitter (e.g. service radio)	Antenna	Electromagnetic field
Ground or reference potential difference	Voltage difference	Transient currents
Operator	Static charge	Electrical discharge currents, electrical field
Power cable	Current flow	Electrical and magnetic field, system disturbance
High-voltage cable	Voltage difference	Electrical field

What interference can affect RFID?

Interference source	Cause	Remedy
Switched-mode power supply	Interference emitted from the current infeed	<ul style="list-style-type: none"> • Replace the power supply • Ferrite in the supply line
Interference injected through the cables connected in series	Cable is inadequately shielded	Better cable shielding
	The reader is not connected to ground.	Ground the reader
HF interference over the antennas	caused by another reader	<ul style="list-style-type: none"> • Position the antennas further apart. • Erect suitable damping materials between the antennas. • Reduce the power of the readers. <p>Please note the instructions in the Section <i>Installation guidelines/reducing the influence of metal</i></p>
	from external noise sources (frequency converters, fluorescent lamps, etc.)	<ul style="list-style-type: none"> • Minimize sources of noise • Shield • Compensation • Point-to-point grounding

Coupling paths

A coupling path has to be present before the disturbance emitted by the interference source can affect the system. There are four ways in which interference can be coupled in:

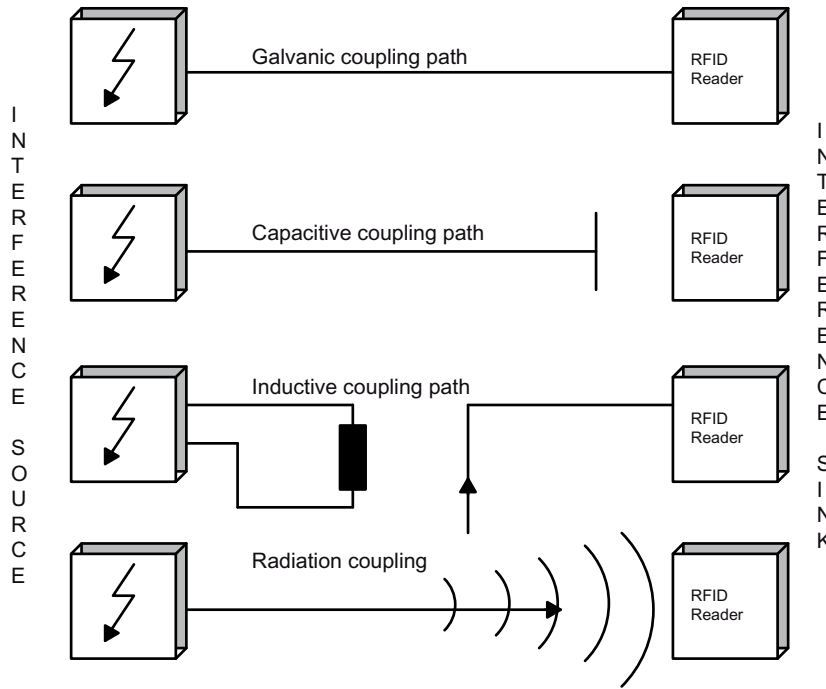

Figure 4-23 Ways in which interference can be coupled in

When RFID modules are used, different components in the overall system can act as a coupling path:

Table 4- 26 Causes of coupling paths

Coupling path	Invoked by
Conductors and cables	<ul style="list-style-type: none"> • Incorrect or inappropriate installation • Missing or incorrectly connected shield • Inappropriate physical arrangement of cables
Control cabinet or housing	<ul style="list-style-type: none"> • Missing or incorrectly wired equalizing conductor • Missing or incorrect earthing • Inappropriate physical arrangement • Components not mounted securely • Unfavorable cabinet configuration

4.5.5 Cabinet configuration

The influence of the user in the configuration of an electromagnetically compatible plant encompasses cabinet configuration, cable installation, ground connections and correct shielding of cables.

Note

For information about electromagnetically compatible cabinet configuration, please consult the installation guidelines for SIMATIC PLCs.

Shielding by enclosure

Magnetic and electrical fields and electromagnetic waves can be kept away from the interference sink by using a metal enclosure. The easier the induced interference current can flow, the greater the intrinsic weakening of the interference field. All enclosures and metal panels in the cabinet should therefore be connected in a manner allowing good conductance.

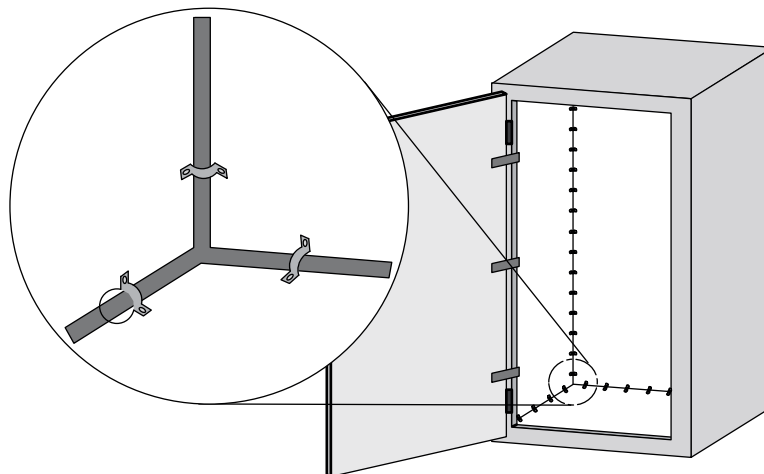

Figure 4-24 Shielding by enclosure

If the control cabinet panels are insulated from each other, a high-frequency-conducting connection can be established using ribbon cables and high-frequency terminals or HF conducting paste. The larger the area of the connection, the greater the high-frequency conductivity. This is not possible using single-wire connections.

Prevention of interference by optimum configuration

Good interference suppression can be achieved by installing SIMATIC PLCs on conducting mounting plates (unpainted). When setting up the control cabinet, interference can be prevented easily by observing certain guidelines. Power components (transformers, drive units, load power supply units) should be arranged separately from the control components (relay control unit, SIMATIC S7).

As a rule:

- The effect of the interference decreases as the distance between the interference source and interference sink increases.
- The interference can be further decreased by installing grounded shielding plates.
- The load connections and power cables should be installed separately from the signal cables with a minimum clearance of 10 cm.

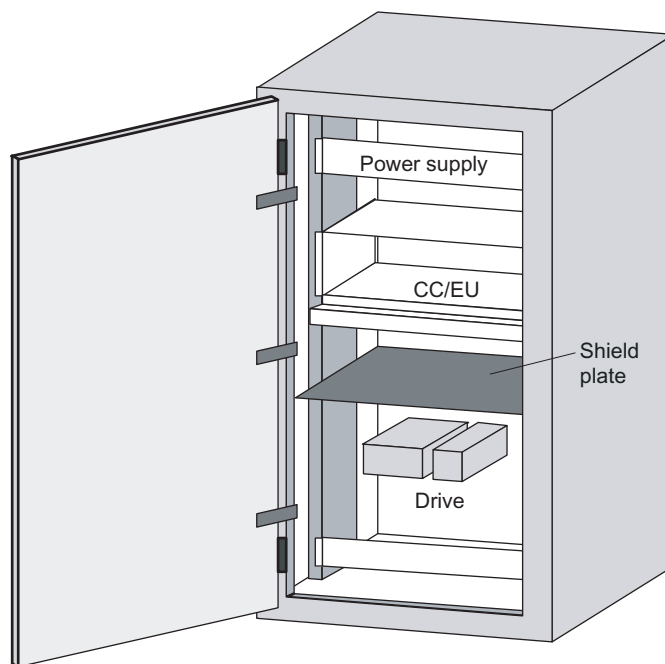

Figure 4-25 Prevention of interference by optimum configuration

Filtering of the supply voltage

External interference from the mains can be prevented by installing line filters. Correct installation is extremely important, in addition to appropriate dimensioning. It is essential that the line filter is mounted directly at the cabinet inlet. As a result, interference is filtered promptly at the inlet, and is not conducted through the cabinet.

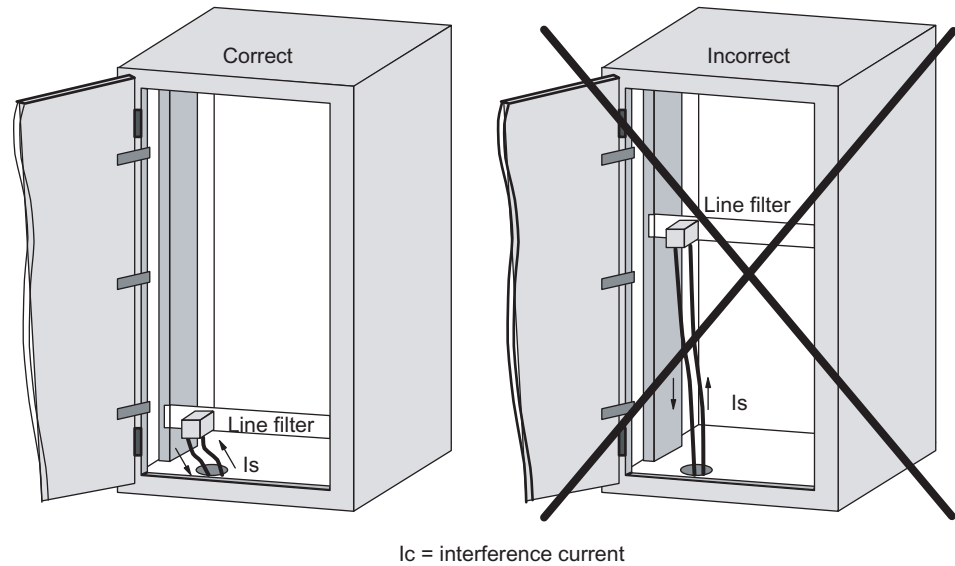

Figure 4-26 Filtering of the supply voltage

4.5.6 Prevention of interference sources

A high level of immunity to interference can be achieved by avoiding interference sources. All switched inductances are frequent sources of interference in plants.

Suppression of inductance

Relays, contactors, etc. generate interference voltages and must therefore be suppressed using one of the circuits below.

Even with small relays, interference voltages of up to 800 V occur on 24 V coils, and interference voltages of several kV occur on 230 V coils when the coil is switched. The use of freewheeling diodes or RC circuits prevents interference voltages and thus stray interference on conductors installed parallel to the coil conductor.

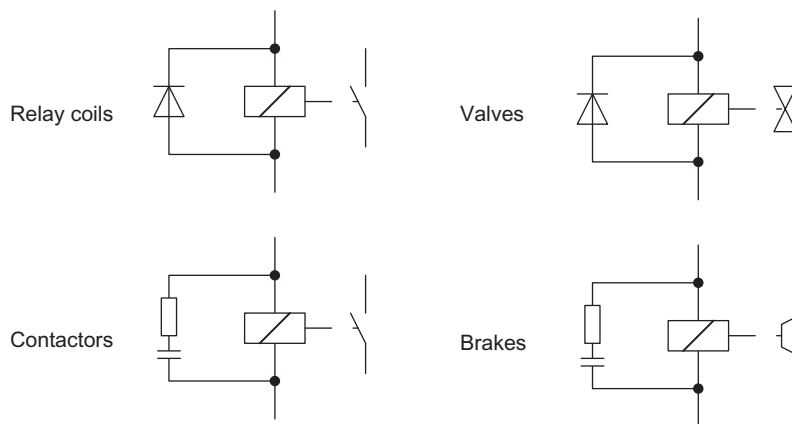

Figure 4-27 Suppression of inductance

Note

All coils in the cabinet should be suppressed. The valves and motor brakes are frequently forgotten. Fluorescent lamps in the control cabinet should be tested in particular.

4.5.7 Equipotential bonding

Potential differences between different parts of a plant can arise due to the different design of the plant components and different voltage levels. If the plant components are connected across signal cables, transient currents flow across the signal cables. These transient currents can corrupt the signals.

Proper equipotential bonding is thus essential.

- The equipotential bonding conductor must have a sufficiently large cross section (at least 10 mm²).
- The distance between the signal cable and the associated equipotential bonding conductor must be as small as possible (antenna effect).
- A fine-strand conductor must be used (better high-frequency conductivity).
- When connecting the equipotential bonding conductors to the centralized equipotential bonding strip (EBS), the power components and non-power components must be combined.
- The equipotential bonding conductors of the separate modules must lead directly to the equipotential bonding strip.

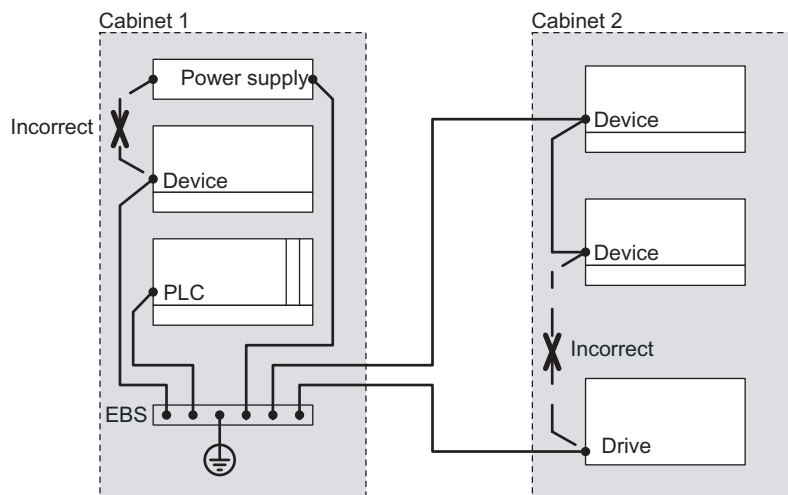

Figure 4-28 Equipotential bonding (EBS = Equipotential bonding strip)

The better the equipotential bonding in a plant, the smaller the chance of interference due to fluctuations in potential.

Equipotential bonding should not be confused with protective earthing of a plant. Protective earthing prevents the occurrence of excessive shock voltages in the event of equipment faults whereas equipotential bonding prevents the occurrence of differences in potential.

4.5.8 Ground-fault monitoring with MOBY

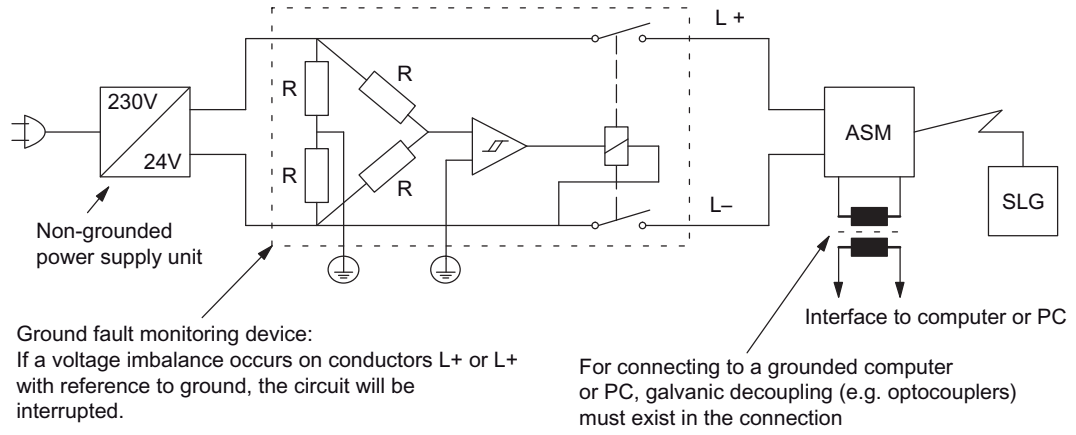

Figure 4-29 Schematic diagram of ground-fault monitoring

4.5.9 Cable shielding

Signal cables must be shielded in order to prevent coupling of interference.

The best shielding is achieved by installing the cables in steel tubes. However, this is only necessary if the signal cable is routed through an environment prone to particular interference. It is usually adequate to use cables with braided shields. In either case, however, correct connection is vital for effective shielding.

Note

An unconnected or incorrectly connected shield has no shielding effect.

As a rule:

- For analog signal cables, the shield should be connected at one end on the receiver side
- For digital signals, the shield should be connected to the enclosure at both ends
- Since interference signals are frequently within the HF range (> 10 kHz), a large-area HF-proof shield contact is necessary

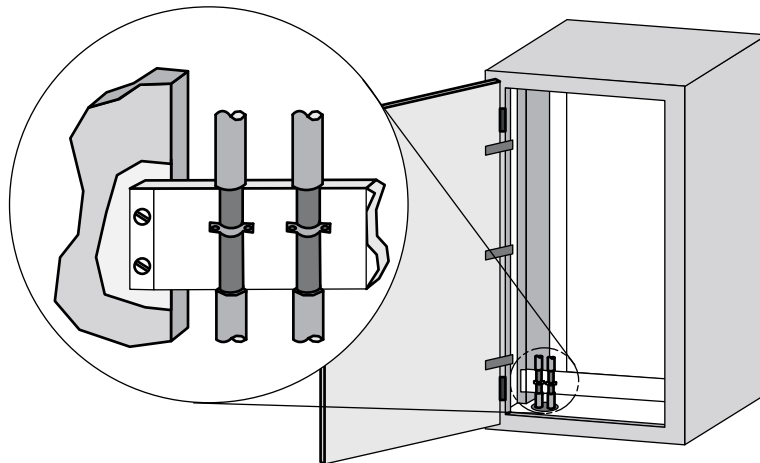

Figure 4-30 Cable shielding

The shielding bus should be connected to the control cabinet enclosure in a manner allowing good conductance (large-area contact) and must be situated as close as possible to the cable inlet. The cable insulation must be removed and the cable clamped to the shielding bus (high-frequency clamp) or secured using cable ties. Care should be taken to ensure that the connection allows good conductance.

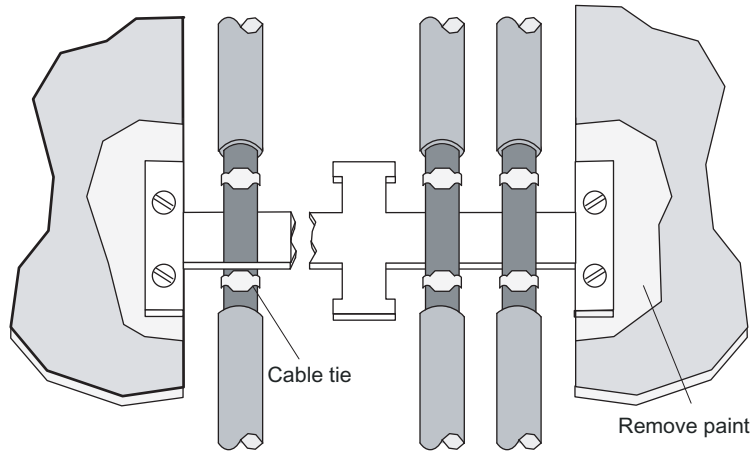

Figure 4-31 Connection of shielding bus

The shielding bus must be connected to the PE busbar.

If shielded cables have to be interrupted, the shield must be continued via the corresponding connector housing. Only suitable connectors may be used for this purpose.

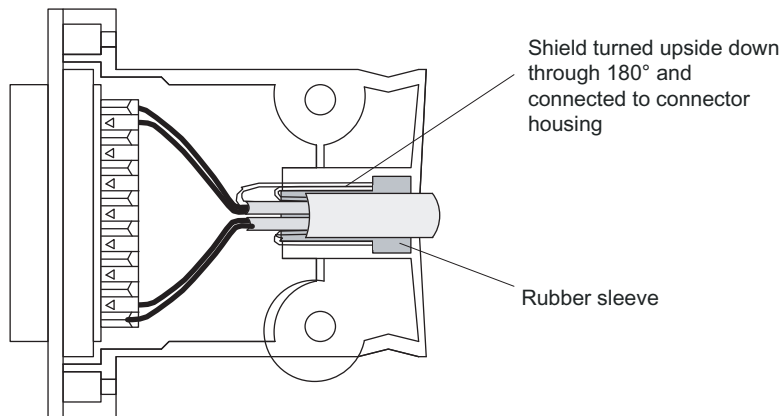

Figure 4-32 Interruption of shielded cables

If intermediate connectors, which do not have a suitable shield connection, are used, the shield must be continued by fixing cable clamps at the point of interruption. This ensures a large-area, HF-conducting contact.

4.6 MOBY shield concept

In MOBY, the data are transferred between the ASM and SLG at different baudrates over an RS 422 interface. The distance between the ASM and SLG can be up to 1000 m. In terms of cabling, MOBY must be handled in the same manner as a data processing system. Particular attention must be paid to the shield route for all data cables. In the following drawings, the most important aspects of reliable installation are shown.

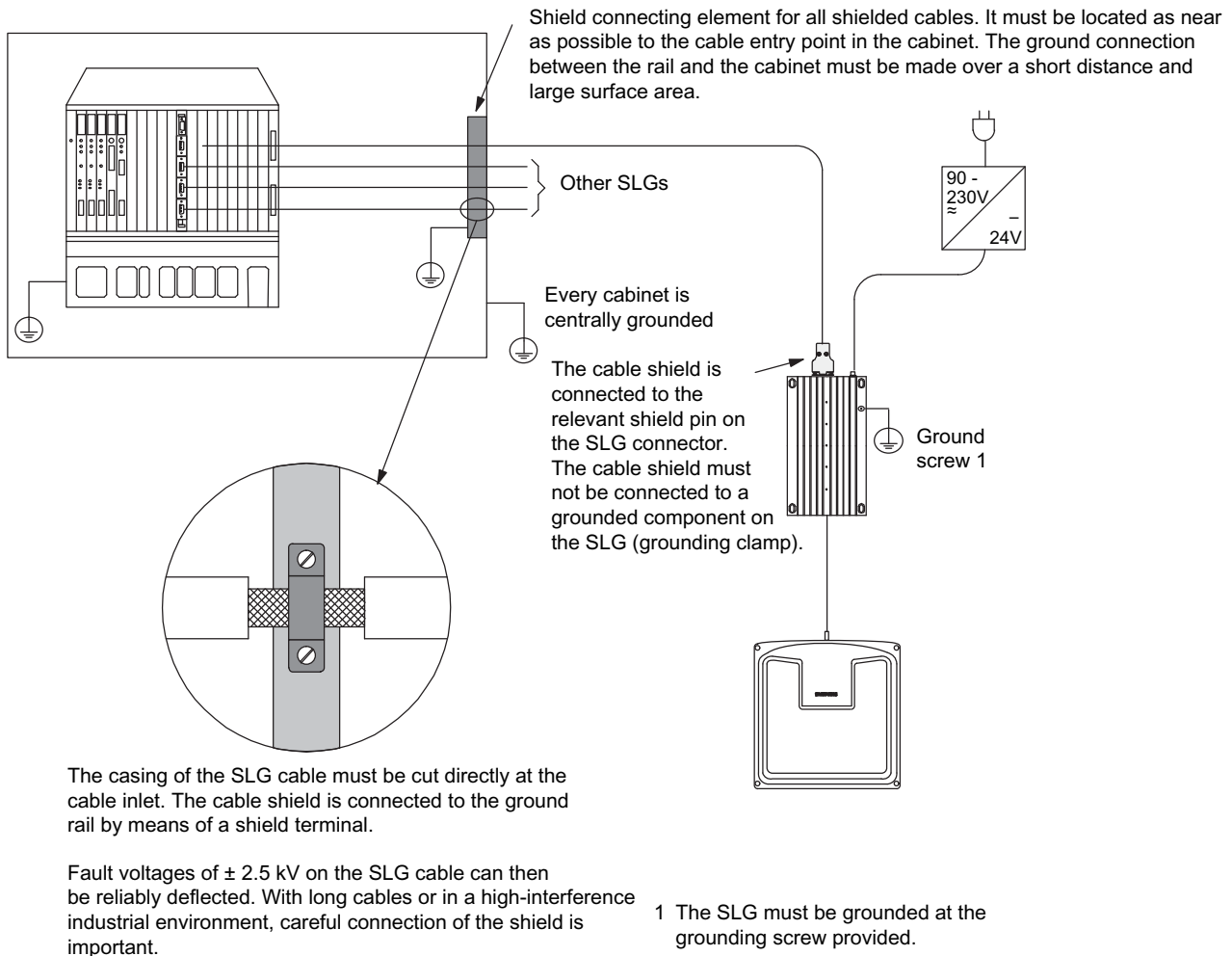

Figure 4-33 Basic shield connection

Connection of other modules

To divert fault currents that can occur on the connecting cable on the SLG, the same procedure must be followed as shown in the figure above.

Configuration of an S7-300 with MOBY

When the SLG is connected to ASM 475, the cable shield must be connected to a shield terminal. Shield terminals and holding clips are standard components of the product spectrum of S7-300.

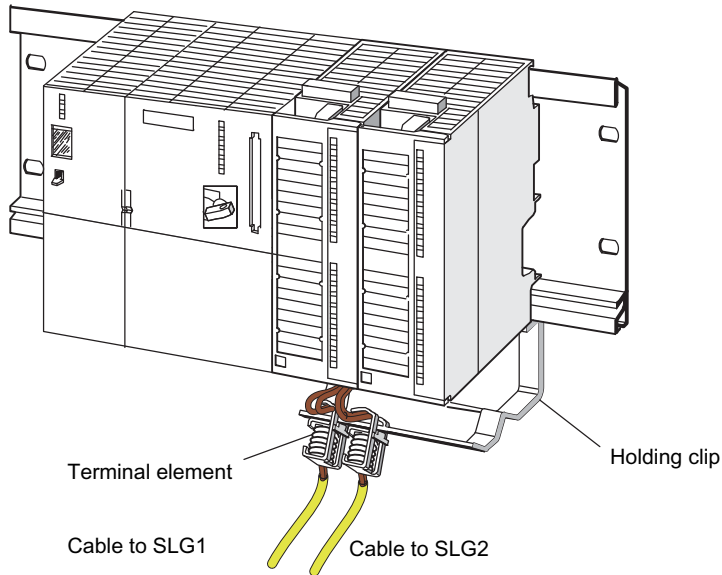

Figure 4-34 Configuration of ASM 475 with shield connecting element

Cable assembly for ASM 475

To achieve electromagnetic compatibility, the SLG cable must be routed via an S7-300 shield connecting element (see previous diagram). The cable shield should be exposed as shown in the diagram below.

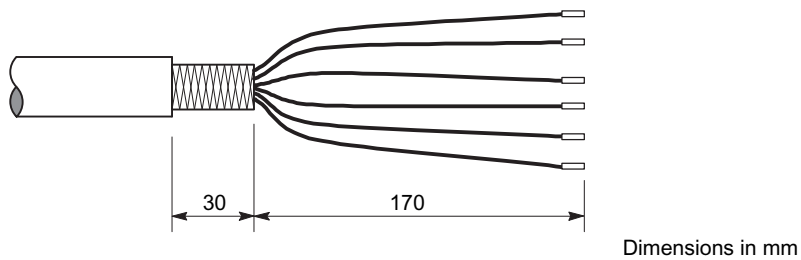

Figure 4-35 Exposure of the cable shield

4.7 Cable and connector assignment

The casing of the standard data cable for the SLG used with MOBY is polyurethane (PUR according to VDE 0250). This provides excellent protection to the cable against oils, acids, alkalis and hydraulic fluids.

4.7.1 Cable configuration

The cable between the PC and SLG must have three cores and a shield.
The data can be transferred largely independently of the wire diameter over distances of up to 30 m (depending on the baudrate).

Standard cable recommended by Siemens: LiYC11Y

Grounding of the SLG cable

It is generally recommended that the shield is connected to a ground rail over a large surface area.

Trailing cable

The SLG can also be connected over a cable suitable for trailing.
Recommended cable type: HPM Paartronic 3340-C-PUR 3 2 0.25.

Power supply for SLG D1x

Power is supplied to the SLG D1x over a 4-pin M12 connector.

It is essential to consider the voltage drop over the supply cable.

The permissible length of the power supply cable depends on the power consumption of the SLG and the resistance of the connecting cable.

Table 4- 27 Power supply for SLG D1x

	SLG D10/SLG D10S	SLG D11/SLG D11S SLG D12/SLG D12S
Rated value	--- DC 24 V	--- DC 24 V
Permitted range	--- DC 24 V ± 5 % UL only (measured at the SLG connector)	--- DC 20 V ... 30 V (--- DC 24 V ± 5 % UL only) (measured at the SLG connector)
Current consumption	<ul style="list-style-type: none"> • Starting current • Operation at 24 V DC 	<ul style="list-style-type: none"> • 2.8 A/50 ms • 0.9 A (4 W setting) • 1.4 A (10 W setting)
		<ul style="list-style-type: none"> • 0,6 A • 0,15 A

4.7.2 Connector pin assignment for SLG D1x (RS232)

Serial port

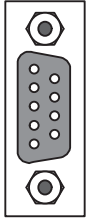
Pin	Pin, casing side (9-pin Sub-D connector with screw locking)	Name SLG D10/D11/D12 (RS 232)
	1	Cable shield
	2	TxD Transmit
	3	RxD Receive
	4	Not assigned
	5	Ground (0 V)
	6	Not assigned
	7	Not assigned
	8	Cable shield
	9	Not assigned
	Housing	Not assigned

Note

When metal Sub D casings are used on the SLG side, the casing must be connected to the cable shield.

Table 4- 28 Ordering data for mating connector for SLG D1x

	Order No.
IP 65 mating connector for SLG D1x 9-pin Sub-D connector, female	6GT2490-1AA00

Power supply

Pin	Pin, casing side 4-pin M12	Name SLG D1x
 <p style="text-align: center;">Plan view</p>	1	Ground (0 V)
	2	+ 24 V
	3	+ 24 V
	4	Ground (0 V)

Table 4- 29 Ordering data for mating connector for power supply

	Order No.
Mating connector for power supply for SLG D1x 4-pin M12 connector, female	6GT2390-1AB00

4.7.3 Connector pin assignment for D1xS (RS422)

Serial port

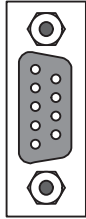
Pin	Pin, casing side (9-pin Sub-D connector with screw locking)	Name SLG D1xS (RS 422)
	1	Cable shield
	2	+ Receive
	3	+ Transmit
	4	Not assigned
	5	- Transmit
	6	- Receive
	7	Ground (0 V)
	8	Cable shield
	9	Not assigned
	Housing	Not assigned

Note

When metal Sub D casings are used on the SLG side, the casing must be connected to the cable shield.

Table 4- 30 Ordering data for mating connector for SLG D1xS

	Order No.
IP 65 mating connector for SLG D1x 9-pin Sub-D connector, female	6GT2490-1AA00

Power supply

Pin	Pin, casing side 4-pin M12	Name SLG D1xS
 <p style="text-align: center;">Plan view</p>	1	Ground (0 V)
	2	+ 24 V
	3	+ 24 V
	4	Ground (0 V)

Table 4- 31 Ordering data for mating connector for power supply

	Order No.
Mating connector for power supply for SLG D1x 4-pin M12 connector, female	6GT2390-1AB00

4.7.4 Connecting cable

24 V plug-in cable for SLG D1x/D1xS ↔ wide-range power supply unit 6GT2491-1HH50

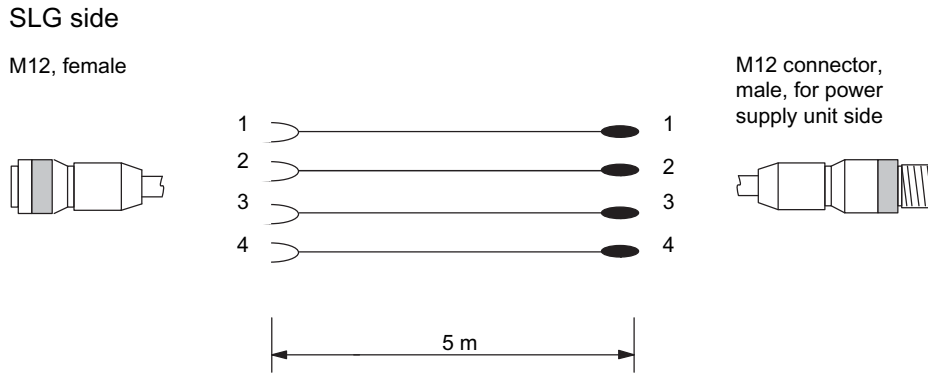

Figure 4-36 24 V DC plug-in cable for SLG D1x/D1xS and wide-range power supply unit (6GT2 494-0AA00)

Cable for SLG D1x ↔ PC/RS 232 6GT2691-0BH50 6GT2691-0BN20

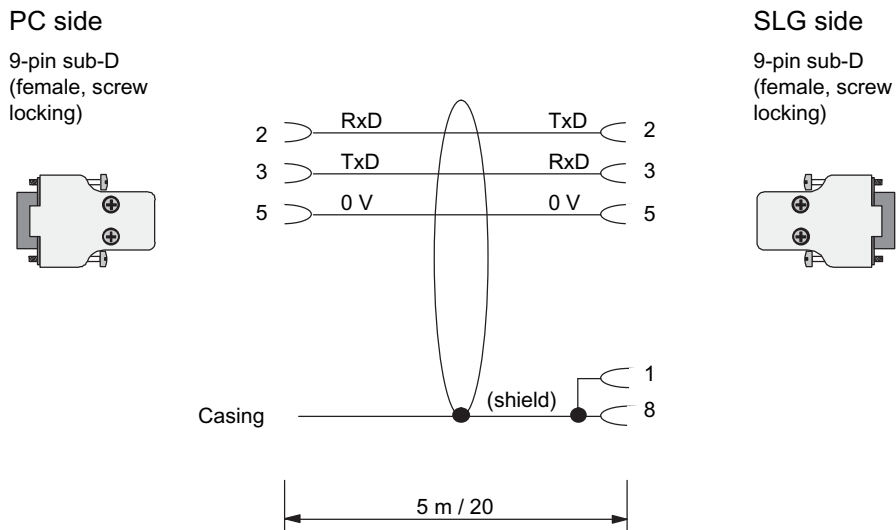
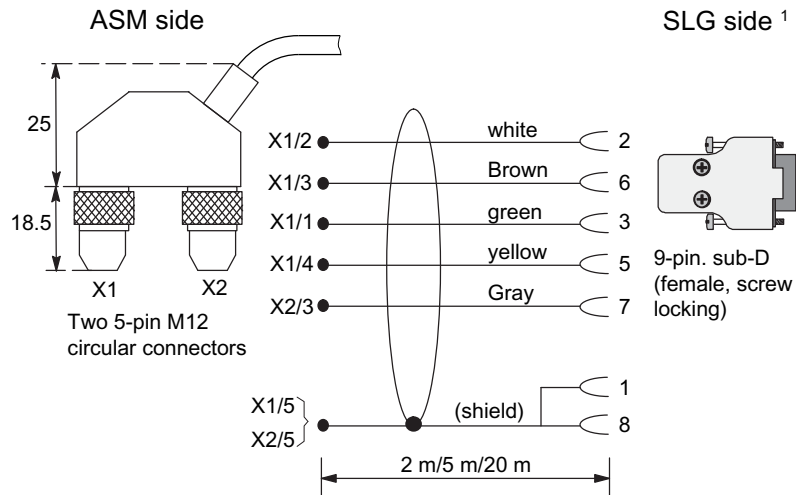

Figure 4-37 Connecting cable RS 232 PC ↔ SLG D1x

Connecting cable SLG D1xS ↔ ASM 452/473
6GT2491-1CH20
6GT2491-1CH50
6GT2491-1CN20



1 Caution:

When metal Sub D casings are used on the SLG side, the casing must be connected to the cable shield.

Figure 4-38 Connecting cable SLG D1xS ↔ ASM 452/473

Connecting cable SLG D1xS ↔ ASM 475

6GT2491-0EH50

6GT2491-0EN20

6GT2491-0EN50

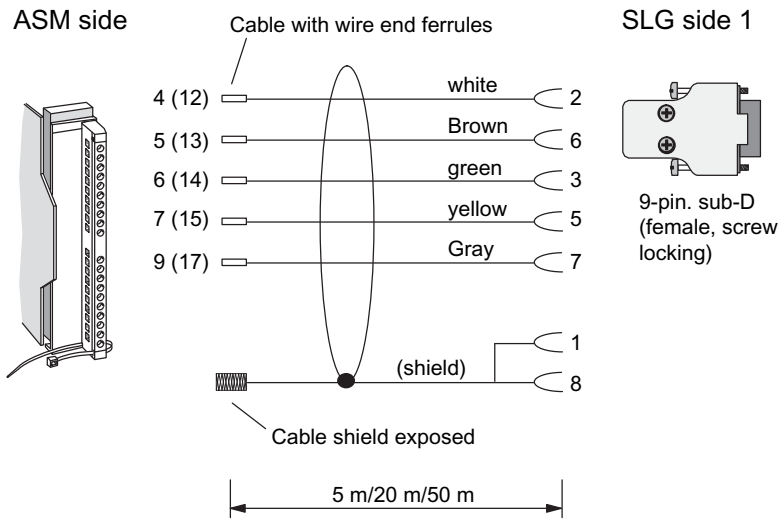

1 Caution:

When metal Sub D casings are used on the SLG side, the casing must be connected to the cable shield.

Figure 4-39 Connecting cable SLG D1xS ↔ ASM 475

Connecting cable SLG D1xS ↔ ASM 456 / RF170C / RF180C

6GT2691-0FH20

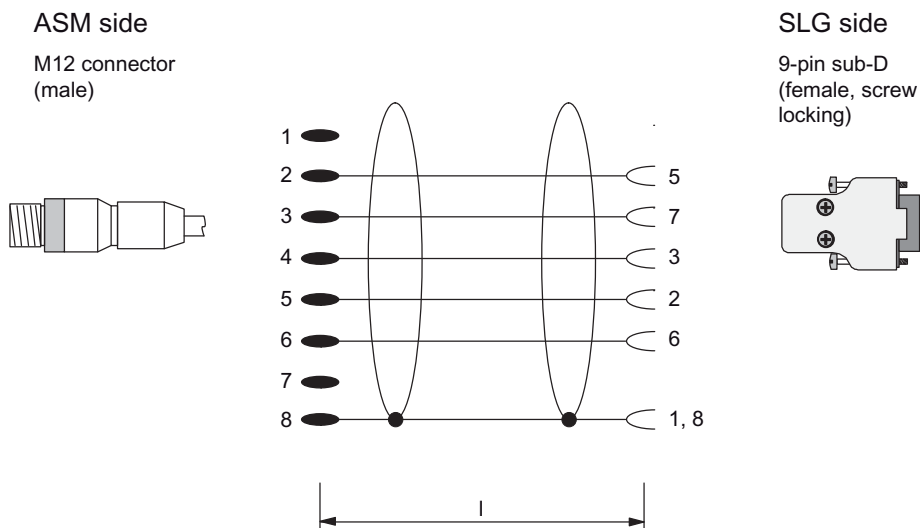

Figure 4-40 Connecting cable SLG D1xS ↔ ASM 456

**Extension cable SLG D1xS ↔ ASM 456 /RF170C / RF180C
6GT2891-0F...**

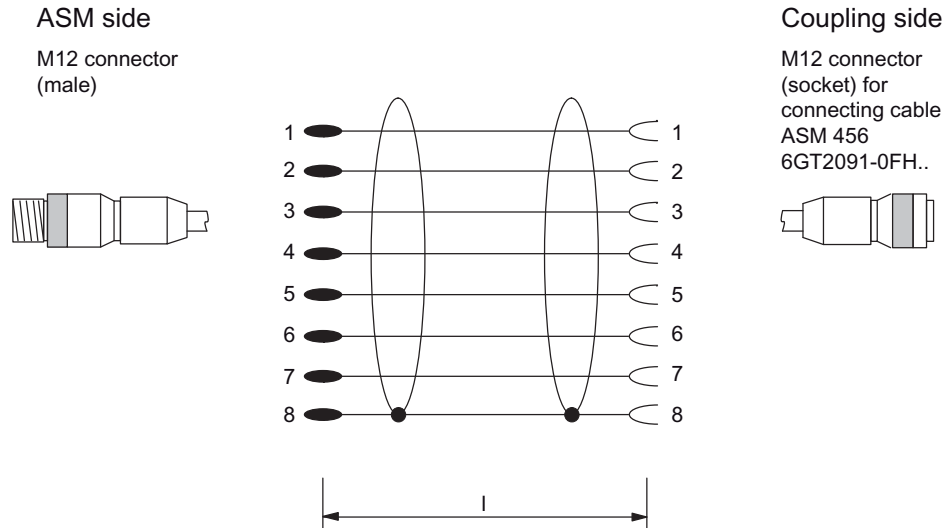

Figure 4-41 Extension cable SLG D1xS ↔ ASM 456

**Antenna connecting cable SLG D10 / SLG D11 / SLG D10S / SLG D11S ↔ ANT Dx
6GT2691-0CH33
6GT2691-0CN10**

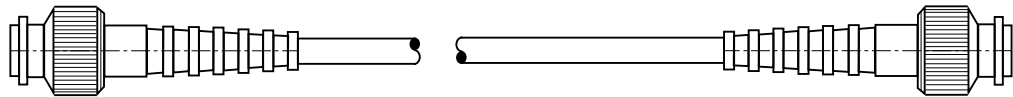

Figure 4-42 ANT antenna connecting cable SLG D10 / SLG D11 / SLG D10S / SLG D11S ↔ ANT Dx
(3.3 m/10.5 m)

**Antenna extension cable
6GT2691-0DH72**

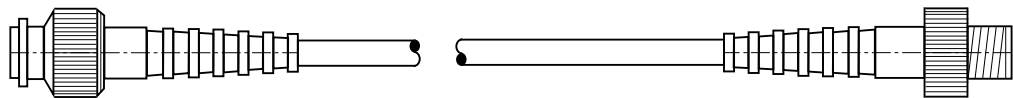

Figure 4-43 Antenna extension cable (7.2 m)

Mobile data storage units

5.1 Introduction

Application area

MOBY identification systems support automatic, fast and reliable identification. The important data accompany the product throughout the complete logistics and transport process. When fitted to the item to be identified, data can be stored on the MDS contact-free and either updated or read out contact-free at any point in the material flow process. Different types of MDS can be selected to suit the specific application. Rugged transponder construction supports use under harsh industrial conditions at high temperatures and makes the MDS resistant to many chemical substances.

Design and function

The main components of the mobile data storage unit (MDS) are logic, antenna and EEPROM. If an MDS moves into the transmission field of the SLG (write/read device), the necessary power for all circuit components is generated and monitored by means of the energy supply unit. The pulse-coded information is prepared in such a way that it can be processed further as pure digital signals. The control unit handles the data and the check routines.

Overview

Table 5- 1 MDS overview table

MDS	Memory size	Temperature range (in operation)	Dimensions (L x W x H in mm)	Degree of protection
MDS D100	EEPROM 128 bytes gross 112 bytes net	-25 to +80 °C	85 x 54 x 0.8	IP68
MDS D124	EEPROM 128 bytes gross 112 bytes net	-25 to +125 °C (180 °C for 1000 h)	Ø 27 x 4	IP68/X 9K
MDS D139	EEPROM 128 bytes gross 112 bytes net	-25 to +140 °C (220 °C for 2000 h)	Ø 85 x 15	IP68/X 9K
MDS D160	EEPROM 128 bytes gross 112 bytes net	-25 to +85 °C (125 °C for 1000 h)	Ø 16 x 3	IP68/X 9K
MDS D165	EEPROM 128 bytes gross 112 bytes net	-25 to +85 °C	85 x 54 x 0.3	IP65
MDS D200	EEPROM 256 bytes gross 256 bytes net	-20 to +60 °C	85 x 54 x 0.6	IP67
MDS D261	EEPROM 256 bytes gross 256 bytes net	-25 to +85 °C	55 x 55 x 0.3	IP65
MDS D324	EEPROM 1024 bytes gross 992 bytes net	-25 to +125 °C	Ø 27 x 4	IP67
MDS D424	EEPROM 2048 bytes gross 2000 bytes net	-25 to +85 °C	Ø 27 x 4	IP67
MDS D428	EEPROM 2048 bytes gross 2000 bytes net	-25 to +85 °C	Ø 27 x 20 SW 22, M8 thread	IP68/X 9K
MDS D460	EEPROM 2048 bytes gross 2000 bytes net	-25 to +85 °C	Ø 16 x 3	IP67/X 9K

Definition of IP67:

- Protection against the ingress of dust (dustproof)
- Complete touch protection
- Protection against water under specified pressure and for specified time

Definition of IP68:

- Protection against the ingress of dust (dustproof)
- Complete touch protection
- The MDS can be submerged in water for long periods; the conditions must be clarified with the manufacturer.

Memory allocation of the MDS

Memory division for PC applications of ISO 15693 transponders

The MDS D1xx are based on the NXP I-Code SL2 and have a 128-byte EEPROM memory that is subdivided into 32 blocks. A block on the transponder is the smallest addressable memory area and is subdivided into areas of 4 bytes in length for access. 112 bytes (= 28 blocks) can be used by the user.

The MDS D2xx are based on the Texas HF-I and have a 256-byte EEPROM memory that is subdivided into 64 blocks. A block on the transponder is the smallest addressable memory area and is subdivided into areas of 4 bytes in length for access. All 256 bytes (= 64 blocks) can be used by the user.

The MDS D3xx are based on the Infineon SRF55V10P and have a 1024-byte EEPROM memory that is subdivided into 256 blocks. A block on the transponder is the smallest addressable memory area and is subdivided into areas of 4 bytes in length for access. 992 bytes (= 248 blocks) can be used by the user.

The MDS D4xx are based on the Fujitsu MB89R118B and have a 2048-byte FRAM memory that is subdivided into 256 blocks. A block on the transponder is the smallest addressable memory area and is subdivided into areas of 8 bytes in length for access. 2000 bytes (= 250 blocks) can be used by the user.

5.2 Memory configuration of the ISO tags

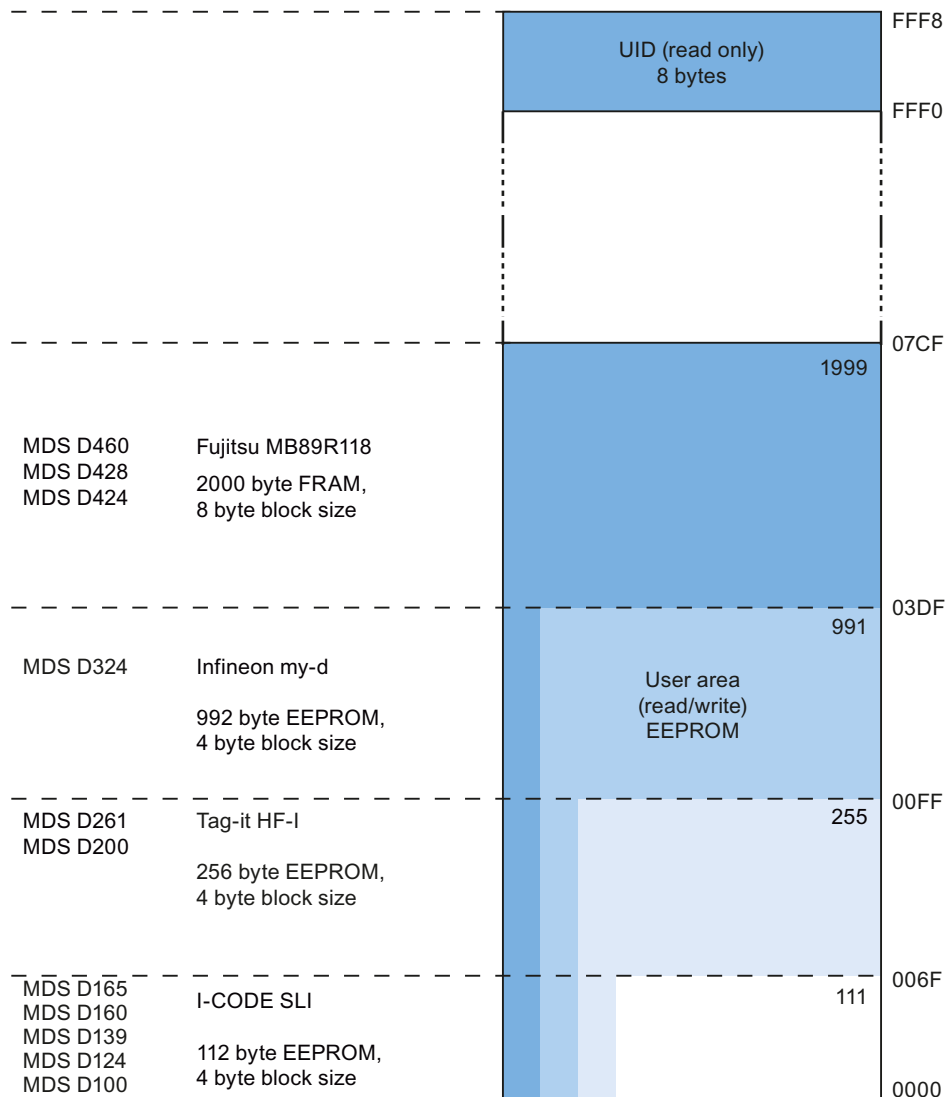

Figure 5-1 Memory configuration

Memory areas

Depending on the manufacturer of the transponder chip, the memory configuration of an ISO tag consists of EEPROM memory of varying sizes. Except for transponders that are equipped with a Fujitsu 2k FRAM. These are equipped with one FRAM.

The typical sizes are 112 bytes, 256 bytes, 992 bytes or 2000 bytes. Each ISO transponder chip features an 8-byte unique serial number (UID, read only). This UID is transferred as an 8 byte value through a read command to address FFF0 with a length of 8.

5.3 MDS D100

5.3.1 Characteristics

MDS D100	Characteristics	
	Field of application	From simple identification such as electronic barcode replacement/supplementation, through warehouse and distribution logistics, right up to product identification.
	Memory	EEPROM 128 bytes gross 112 bytes net capacity
	Read/write range	See Chapter Field data (Page 33).
	Mounting on metal	Not possible; recommended distance from metal ≥ 20 mm
	ISO standard	ISO 15693

5.3.2 Ordering data

Table 5- 2 Ordering data for MDS D100

	Order number
MDS D100	6GT2600-0AD10

Table 5- 3 Ordering data for MDS D100 accessory

MDS D100 accessory	Order number
Spacers	6GT2190-0AA00
Fixing pocket	6GT2190-0AB00
Fixing pocket (cannot be mounted directly on metal)	6GT2390-0AA00

5.3.3 Metal-free area

Direct mounting of the MDS D100 on metal is not allowed. A distance of ≥ 20 mm is recommended. This can be achieved using the spacer 6GT2190-0AA00 in combination with the fixing pocket 6GT2190-0AB00.

Mounting on metal

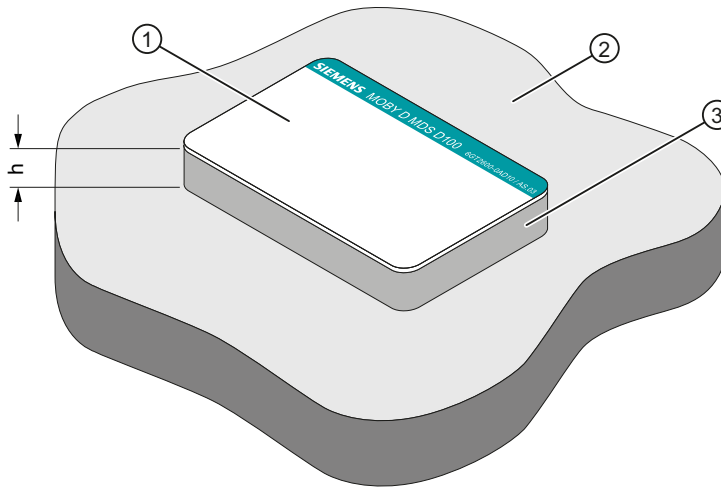

- h ≥ 20 mm
- ① Data memory
- ② Metal
- ③ Non-metal

Figure 5-2 Mounting of the MDS D100 on metal with spacer

Flush-mounting

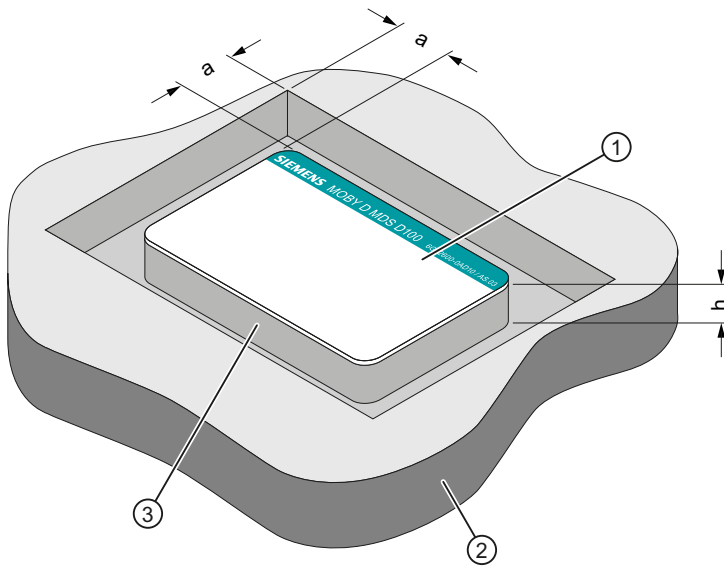

- a ≥ 20 mm
- h ≥ 20 mm
- ① Data memory
- ② Metal
- ③ Non-metal

Figure 5-3 Flush-mounting of MDS D100 in metal with spacer

Note

If the minimum guide values (h) are not observed, a reduction of the field data results.

See also

Dimension drawing (Page 105)

5.3.4 Mounting options

Fixing pocket for MDS D100

The fixing pocket is secured on a non-metallic surface with M4 countersunk head screws in the holes provided.

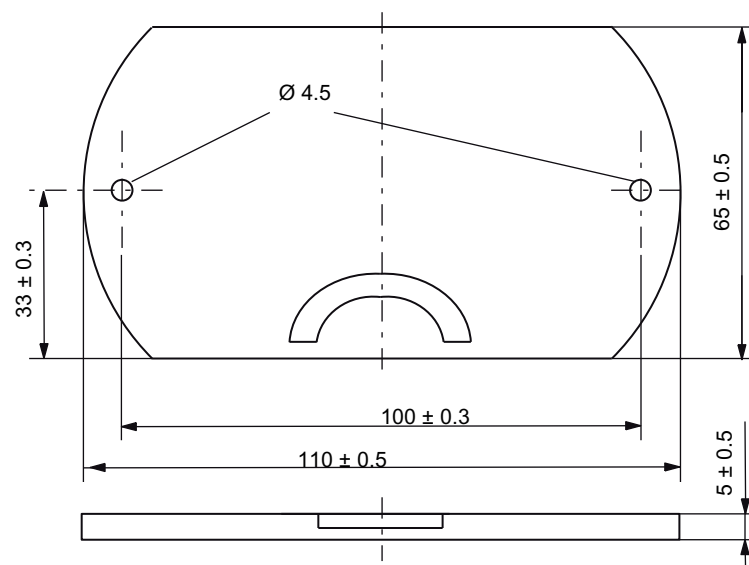

Figure 5-4 Fixing pocket 6GT2390-0AA00 for MDS D100

Note

The fixing pocket shown here with Order No.: 6GT2 390-0AA00 is not suitable for use with the spacer (6GT2 190-0AA00).

Note

When mounting the MDS D100 on metal, it is also possible to use the 6GT2 190-0AB00 fixing pocket, but only in combination with the 6GT2 190-0AA00 spacer.

Fixing pocket with spacer for MDS D100

Dimension sketch

Spacers: 6GT2190-0AA00

Mounting bracket: 6GT2190-0AB00

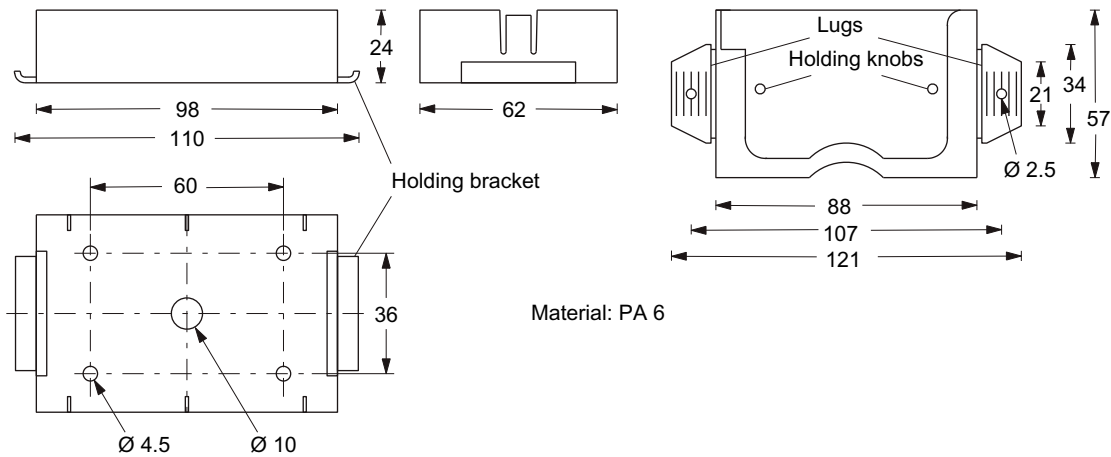

The spacer can be mounted directly on metal. Together with the mounting bracket, this results in a distance of 20 mm between transponder and metal.

Mounting:

- With 2 or 4 screws (M4)
- With rubber pads on the holding brackets (e.g. on mesh boxes)
- With cable ties on the holding brackets (e.g. on mesh boxes)

Transponder with mounting bracket

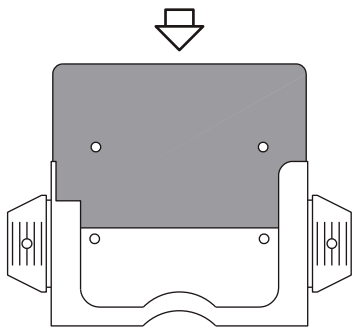

The transponder is pushed into the mounting bracket. Locking takes place with holding knobs in the mounting bracket.

Transponder with mounting bracket and spacer (assembled)

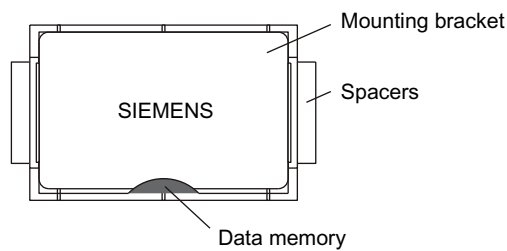

Re-assembly instructions:

Slide transponder into the mounting bracket. The tabs are then bent by 90° and inserted into the spacer. Position the mounting bracket so that it covers the transponder (see Figure). It is automatically locked into place.

The tabs of the mounting bracket are secured to a non-metal base. This can be done as follows:

- Screws in the holes provided
- Rivets in the holes provided
- Nails through the holes
- Staples through the plastic of the tabs
- Insertion in the spacer

The tabs can also be bent by 90°.

Figure 5-5 Dimensions of the spacer and fixing pocket 6GT2190-0AB00 for MDS 100

Mounting option using drill holes on the MDS

You can also secure the MDS D100 with screws. You must drill the marked holes for this purpose (see Dimension drawing (Page 105)).

- Drill hole/setting max. 3.5 mm,
- Screw according to DIN 4017: M3, head diameter max. 6 mm

5.3.5 Technical data

Table 5- 4 Technical data for MDS D100

Memory size	128 bytes
Memory configuration	<ul style="list-style-type: none"> • Serial number • Configuration memory • Application memory
	<ul style="list-style-type: none"> • 8 bytes (fixed code) • 8 bytes • 112 bytes
Storage technology	EEPROM
Memory organization	EEPROM 128 bytes gross 112 bytes net capacity When using the OPT area, 16 bytes of it must be subtracted in 4 byte blocks
Protocol	according to ISO 15693
Data retention (at +40 °C)	10 years
MTBF (at +40 °C)	2 x 10 ⁶ hours
Read cycles	Unlimited
Write cycles, typical	1 000 000
Write cycles, min.	100 000
Read/write distance (S _g)	See Chapter .
Distance from metal	min. 20 mm (approx. 30% reduction of the field data)
Multitag capability	Yes
Power supply	Inductive power transmission (without battery)
Degree of protection to EN 60529	IP68
Vibration	ISO 10373/ISO 7810
Torsion and bending load	ISO 10373/ISO 7816-1
Mechanical design	Laminated plastic card, printable on both sides
	<ul style="list-style-type: none"> • Color • Material • Dimensions (L x W x H) in mm
	<ul style="list-style-type: none"> • White/petrol • PC • 85.6 (±0.2) x 54 (±0.2) x 0.9 (±0.05)
Fixing	Adhesive, fixing pocket
Ambient temperature	<ul style="list-style-type: none"> • During operation • Transport and storage
	<ul style="list-style-type: none"> • -25 °C to +80 °C • -25 °C to +80 °C
Weight, approx.	5 g

5.3.6 Dimension drawing

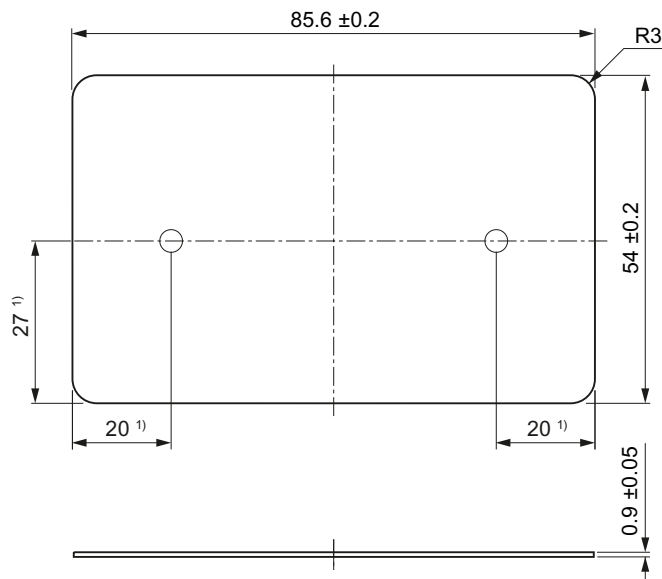

Dimensions in mm

¹⁾ Dimensions for mounting holes

Figure 5-6 MDS D100 dimension drawing

5.4 MDS D124

5.4.1 Characteristics

MDS D124	Characteristics	
	Field of application	Application areas in factory automation (e.g. small paintshops to 180°C)
	Memory	EEPROM 128 bytes gross 112 bytes net capacity
	Read/write range	See Chapter Field data (Page 33).
	Mounting on metal	Not possible: Recommended distance from metal ≥ 25 mm
	Standard	ISO 15693

5.4.2 Ordering data

Table 5- 5 Ordering data for MDS D124

	Order number
MDS D124	6GT2600-0AC10

5.4.3 Mounting on metal

Mounting on metal

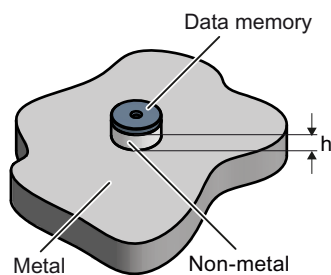

$h \geq 25$ mm

Figure 5-7 Mounting of the MDS D124 on metal with spacer

Flush-mounting

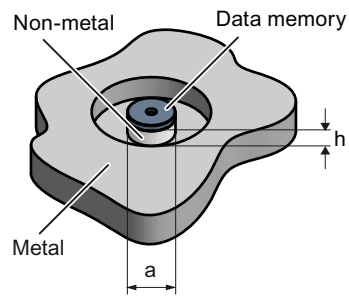

$h \geq 25 \text{ mm}$

$a \geq 25 \text{ mm}$

Figure 5-8 Flush-mounting of MDS D124 in metal with spacer

Note

If the minimum guide values (h) are not observed, a reduction of the field data results. It is possible to mount the MDS with metal screws (M3 countersunk head screws). This has no tangible impact on the range.

5.4.4 Technical specifications

Table 5- 6 Technical data for MDS D124

Memory size	128 bytes
Memory configuration	<ul style="list-style-type: none"> • Serial number • Configuration memory • Application memory
	<ul style="list-style-type: none"> • 8 bytes (fixed code) • 8 bytes • 112 bytes
Storage technology	EEPROM
Memory organization	EEPROM 128 bytes gross 112 bytes net capacity When using the OPT area, 16 bytes of it must be subtracted in 4 byte blocks
Protocol	according to ISO 15693
Data retention (at +40 °C)	10 years
MTBF (at +40 °C)	≥ 1.5 x 10 ⁶ hours
Read cycles	Unlimited
Write cycles at +40 °C, typical	1 000 000
Write cycles, min.	100 000
Read/write distance (S _g)	See Chapter Field data (Page 33).
Distance from metal	min. 25 mm (approx. 30% reduction of the field data)
Multitag capability	Yes
Power supply	Inductive power transmission (without battery)
Degree of protection to EN 60529	IP68 ¹⁾ IPx9K ²⁾
Shock according to EN 60721-3-7, Class 7M3 Total shock response spectrum, Type II	100 g ³⁾
Vibration-resistant to EN 60721-3-7, Class 7M3	20 g ³⁾
Torsion and bending load	Not permissible
Enclosure	<ul style="list-style-type: none"> • Dimensions (D x H) in mm • Color • Material
	<ul style="list-style-type: none"> • 27(±0.2) x 4(±0.2) • Black • Plastic PPS, silicone-free
Fixing	Adhesive, M3 screw
Tightening torque at +20 °C	≤ 1 Nm (at high temperatures, the expansion coefficients of the materials used must be taken into account)

Ambient temperature	During operation	-25 °C to +125 °C	Permanent
		+125 °C to +140 °C	20% reduction in the limit distance
		+180 °C ⁴⁾	Tested up to 5000 hours or 3000 cycles
	Transport and storage	-40 °C to +125 °C	
Weight, approx.		5 g	

- 1) 2 hours, 2 m, +20 °C
- 2) steam jet: 150 mm; 10 to 15 l/min; 100 bar; 75 °C
- 3) The values for shock and vibration are maximum values and must not be applied continuously.
- 4) Note that no processing is possible at temperatures of +140 °C or higher.

5.4.5 Dimension drawing

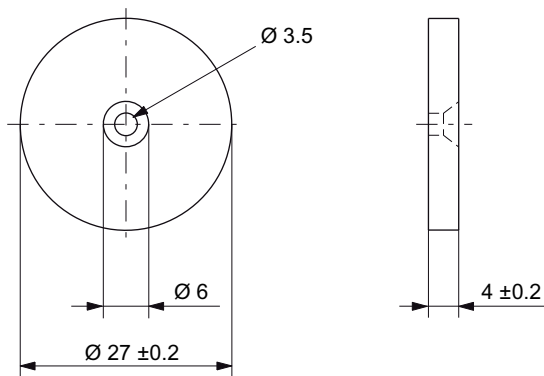

Dimensions in mm

Figure 5-9 Dimension drawing of MDS D124

5.5 MDS D139

5.5.1 Characteristics

MDS D139	Characteristics	
	Field of application	Applications in production logistics and in assembly lines subject to high temperatures (up to +220 °C) Typical application areas: <ul style="list-style-type: none"> • Paintshops and their preparatory treatments) • Primer coat, electrolytic dip area, cataphoresis with the associated drying furnaces • Top coat area with drying furnaces • Washing areas at temperatures > 85 °C • Other applications with higher temperatures
	Memory	EEPROM 128 bytes gross 112-byte user memory
	Read/write range	See Chapter Field data (Page 33).
	Mounting on metal	With spacer; recommended distance from metal ≥ 30 mm
	ISO standard	ISO 15693
	High degree of protection	IP68, IPx9K
	Material	Plastic PPS; silicone-free

5.5.2 Ordering data

Table 5- 7 Ordering data for MDS D139

	Order number
MDS D139	6GT2600-0AA10

Table 5- 8 Ordering data for MDS D139 accessory

MDS D139 accessory	Order number
Spacers Diameter x height: 85 mm x 30 mm	6GT2690-0AA00

5.5.3 Mounting on metal

CAUTION

Damage to the MDS due to improper mounting

For mounting with the spacer (6GT2690-0AA00), use a stainless steel M5 screw to avoid damaging the MDS in high temperatures (expansion coefficients).

In higher temperatures ($> +80\text{ }^{\circ}\text{C}$), observe the expansion coefficients of all materials in order to prevent damage to the MDS due to fastening.

Mounting on metal

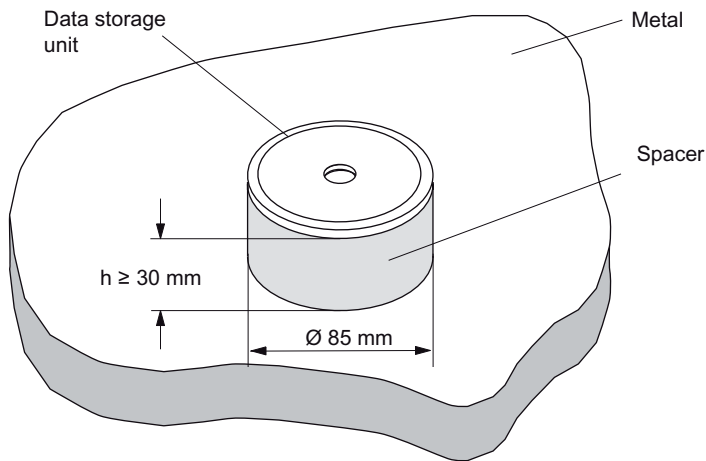

Flush-mounting of the MDS in metal is not permitted!

Figure 5-10 Metal-free area for MDS D139

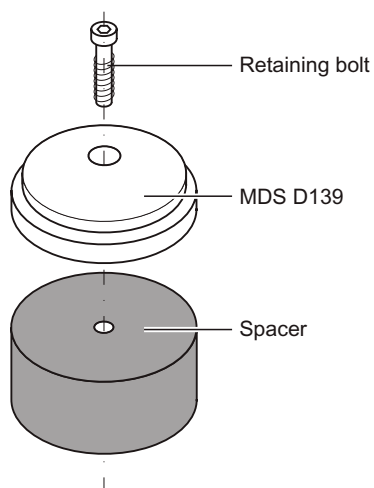

Figure 5-11 MDS D139: Mounting recommended with spacer

Note

If the minimum guide values (h) are not observed, a reduction of the field data results. It is possible to mount the MDS with metal screws (M5). This has no tangible impact on the range. It is recommended that a test is performed in critical applications.

5.5.4 Technical specifications

Table 5- 9 Technical data for MDS D139

Memory size	128 bytes
Memory configuration	
<ul style="list-style-type: none"> • Serial number • Configuration memory • Application memory 	<ul style="list-style-type: none"> • 8 bytes (fixed code) • 8 bytes • 112 bytes
Storage technology	EEPROM
Memory organization	See MOBY D System Manual, Chapter 5.1, "Mobile Data Storage Units, Introduction", section "Memory Allocation"
Data retention	10 years
MTBF	2 x 10 ⁶ hours
Read cycles	Unlimited
Write cycles at +40 °C	
<ul style="list-style-type: none"> • minimum • typical 	<ul style="list-style-type: none"> • 100 000 • 1.000.000
Read/write distance (S _g)	See Chapter Field data (Page 33).
Distance from metal	min. 30 mm (approx. 30% reduction of the field data)
Multitag capability	Yes
Power supply	Inductive power transmission (without battery)
Degree of protection to EN 60529	IP68 ¹⁾ IPx9K ²⁾
Shock according to EN 60721-3-7, Class 7M3 Total shock response spectrum, Type II	50 g
Vibration-resistant to EN 60721-3-7, Class 7M3	20 g
Torsion and bending load	Not permissible
Enclosure dimensions	
<ul style="list-style-type: none"> • Dimensions (D x H) in mm • Color • Material 	<ul style="list-style-type: none"> • 85 (±0.5) x 15 (-1.0) • Black • Plastic PPS, silicone-free
Fixing	3 x M5 screw ¹⁾
Tightening torque	1,5 Nm ⁴⁾

Ambient temperature	• During operation	-25 °C to +100 °C	Permanent
		+120 °C to +140 °C	20% reduction in the limit distance
		+200 °C ⁵⁾	Tested up to 5000 hours or 3000 cycles
		+220 °C	Tested up to 2000 hours or 1500 cycles
	• Transport and storage	-40 °C to +100 °C	
Weight		Approx. 50 g	

- 1) 2 hours, 2 m, +20 °C
- 2) steam jet: 150 mm; 10 to 15 l/min; 100 bar; 75 °C
- 3) For mounting with the spacer (6GT2690-0AA00), use a stainless steel M5 screw to avoid damaging the MDS in high temperatures (expansion coefficient).
- 4) In higher temperatures (> +80 °C), observe the expansion coefficient of all materials in order to prevent damage to the MDS due to fastening.
- 5) Note that no processing is possible at temperatures of +140 °C or higher.

5.5.5 Use of the MDS D139 in potentially explosive environments

The MDS D139 mobile data memory is classed as a piece of simple, electrical equipment and can be operated in Protection Zone 2, Device Group II, Category 3G.

The following requirements of the Directive 94/9/EC are fulfilled:

EN 60079-0 :2006

EN 60079-15 : 2005

Identification



II 3 G Ex nA II T2
 KEMA 09 ATEX 0133 X
 Ta: -25 ... +220°C

⚠ WARNING
Gefahr durch elektrostatische Entladungen
Potential electrostatic charging hazard
Danger potentiel de charges électrostatiques

NOTICE**Installations- und Betriebsbedingungen für den Ex-Schutzbereich:**

- a) Der Einsatz des Gerätes in der Nähe von stark ladungserzeugenden Prozessen ist untersagt.
- b) Das Gerät ist mechanisch geschützt zu montieren.
- c) Die Montage muss auf einem geerdeten, leitenden Untergrund erfolgen.
- d) Die Reinigung darf nur mit feuchtem Tuch erfolgen.

Installation and operating conditions for hazardous areas:

- a) Use of the equipment in the vicinity of processes generating high charges is not allowed.
- b) The equipment must be mechanically protected when installed.
- c) Installation must be performed on a grounded and conductive mounting surface.
- d) Cleaning only with a wet cloth.

Conditions d'installation et de mise en oeuvre pour la zone de protection Ex :

- a) L'utilisation de l'appareil près de processus générant de fortes charges est interdite.
- b) L'appareil doit être monté de manière à être protégé mécaniquement.
- c) Le montage doit être effectué sur un socle conducteur mis à la terre.
- d) Nettoyage uniquement avec un chiffon humide.

5.5.6 Dimensional drawing

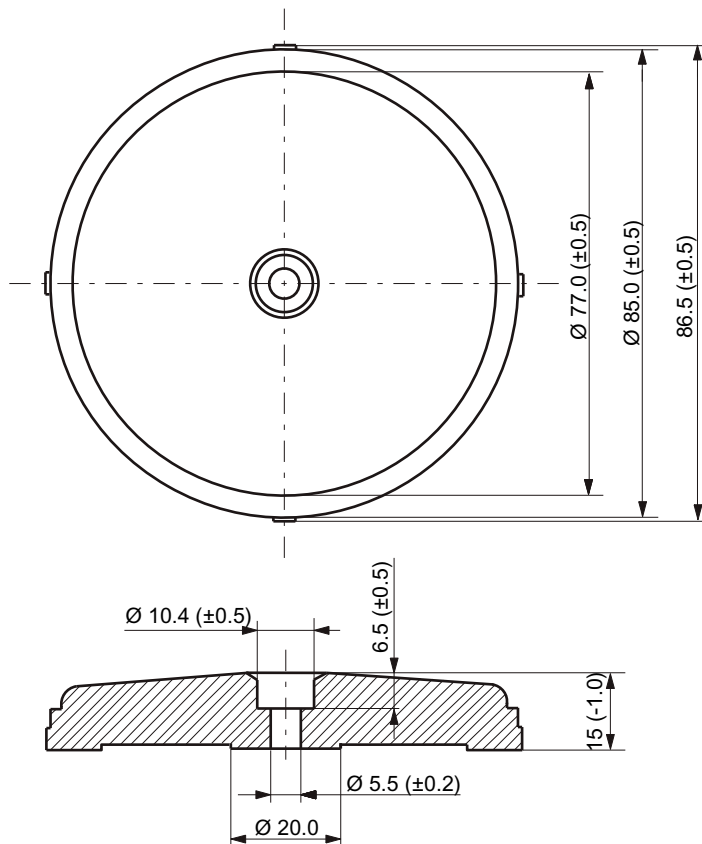

Dimensions in mm

Figure 5-12 Dimensional drawing MDS D139

5.5.7 Cleaning the mobile data memory

NOTICE

Do not clean the transponder with mechanical tools, sand-blasting or pressure hose. These cleaning methods result in damage to the transponder.

Clean the transponder only with the chemical cleansing agents listed in Chapter .

5.6 MDS D160

5.6.1 Characteristics

MDS D160	Characteristics	
	Field of application	Typical applications are, for example: <ul style="list-style-type: none"> • Rented work clothing • Hotel laundry • Surgical textiles • Hospital clothing • Dirt collection mats • Clothing for nursing homes/hostels
	Memory	EEPROM 128 bytes gross 112 bytes net capacity
	Read/write range	See Chapter Field data (Page 33).
	Mounting on metal	Not possible: Recommended distance from metal ≥ 25 mm
	High resistance	Thanks to its rugged packaging, the MDS D160 is a transponder that can be used under extreme environmental conditions. It is washable, heat-resistant and resistant to all chemicals generally used in the laundry process.
	ISO standard	ISO 15693

5.6.2 Ordering data

Table 5- 10 Ordering data for MDS D160

	Order number
MDS D160	6GT2600-0AB10

5.6.3 Mounting on metal

Mounting on metal

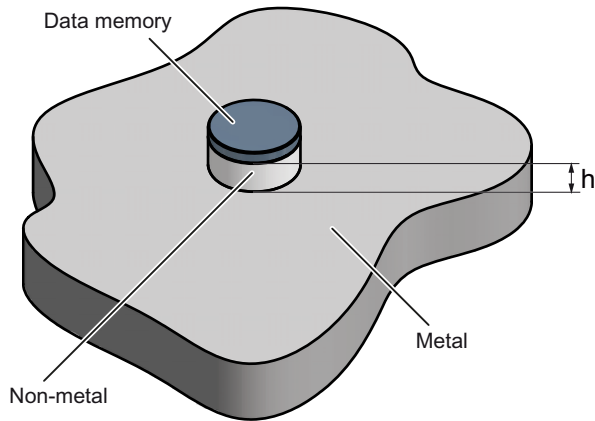

$h \geq 25 \text{ mm}$

Figure 5-13 Mounting of the MDS D160 on metal with spacer

Note

If the minimum guide values (h) are not observed, a reduction of the field data results. In critical applications, it is recommended that a test is performed.

Flush-mounting

Flush-mounting of the MDS D160 in metal is not permitted!

5.6.4 Technical specifications

Memory size	128 bytes
Memory configuration	
<ul style="list-style-type: none"> • Serial number • Configuration memory • Application memory 	<ul style="list-style-type: none"> • 8 bytes (fixed code) • 8 bytes • 112 bytes
Storage technology	EEPROM
Memory organization	EEPROM 128 bytes gross 112 bytes net capacity When using the OPT area, 16 bytes of it must be subtracted in 4 byte blocks
Protocol	According to ISO 15693
Data retention (at +55 °C)	10 years
MTBF (at +40 °C)	2 x 10 ⁶ hours
Bulk detection/multitag capability	Yes
Data retention	10 years
Read cycles	Unlimited
Write cycles at + 40 °C, typical	1 000 000
Write cycles, min.	100 000
Read/write distance (S ₉)	See Chapter Field data (Page 33)
Distance from metal	Min. 25 mm (approx. 30% reduction of the field data)
Power supply	Inductive power transmission (without battery)
Degree of protection to EN 60529	IP68 (24 hours, 2 m, +20 °C)
Shock, tested in accordance with IEC 68-2-27	40 g (18 ms; 6 axes; 2000 repeats/h)
Vibration, tested in accordance with IEC 68-2-6	10 g (10 to 2000 Hz; 3 axes; 2.5 h)
Torsion and bending load	Not permissible
Mechanical strength	
<ul style="list-style-type: none"> • Isostatic pressure • Axial pressure • Radial pressure 	<ul style="list-style-type: none"> • 300 bar for 5 min • 1000 N for 10 s • 1000 N for 10 s
Resistance to chemicals	All chemicals normally used in the washing process
MDS lifespan	At least 100 wash cycles
Mechanical design	
<ul style="list-style-type: none"> • Color • Material • Dimensions (D x H) in mm 	<ul style="list-style-type: none"> • White • PPS, pressed, impact-resistant plastic • 16(±0.2) x 3,0(±0.2)
MDS fixing	Patch, sew, glue

Ambient temperature	During operation	-25 °C to +85 °C	Permanent
		+125 °C	for 1000 hours (20% reduction in the limit distance)
		+175 °C ¹⁾	500 x for 10 minutes
		+220 °C ¹⁾	1 x for 30 seconds
	Transport and storage	-25 °C to +100 °C	
Weight, approx.		1 g	

¹⁾ No processing possible from +140 °C upwards

Note

- Regeneration time for the MDS D160 between wash cycles must be at least 24 hours
- It is recommended that a test is performed in critical applications.

5.6.5 Dimension drawing

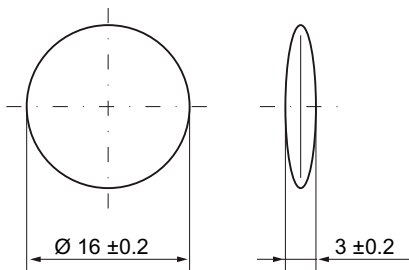

Dimensions in mm

Figure 5-14 Dimension drawing of MDS D160

5.7 MDS D165

5.7.1 Features

MDS D165 (special version)	Features	
	Application area	The design of the transponder (self-adhesive label) permits a variety of designs, guaranteeing optimum dimensioning for the widest variety of applications. From simple identification such as electronic barcode replacement/supplementation, through warehouse and distribution logistics, right up to product identification.
	Memory	112-byte user memory
	Read/write range	See Chapter Field data (Page 33).
	ISO standard	15693 with I-Code SLI technology.

5.7.2 Ordering data

Table 5- 11 Ordering data for MDS D165

	Order No.
MDS D165 (special version ISO-CARD)	6GT2600-1AB00-0AX0

Type of delivery

Minimum order quantity: 1250 units (5 rolls with 250 units each)

5.7.3 Technical data

Memory configuration	
<ul style="list-style-type: none"> • Serial number (UID) • Configuration memory • AFI/DSFID • Application memory 	<ul style="list-style-type: none"> • 8 bytes (fixed code) • 6 bytes • 2 bytes • 112 bytes
Storage technology	EEPROM
Memory organization	4 bytes, block by block
Protocol	according to ISO 15693
Data transmission rate	
<ul style="list-style-type: none"> • reading • writing 	<ul style="list-style-type: none"> • approx. 3.5 ms/byte • approx. 9.5 ms/byte
Multitag capability	Yes
Data retention	10 years
Read cycles	Unlimited
Write cycles, min.	100 000
Recommended distance to metal	25 mm (approx. 30% reduction of the field data)
Power supply	Inductive power transmission (without battery)
Typical read/write distance (Sg)	See Chapter Field data (Page 33)
Degree of protection according to EN 60529	IP65
Dimensions	
<ul style="list-style-type: none"> • L x W (in mm) • Height 	<ul style="list-style-type: none"> • 86 x 54 • approx. 0.3 mm
Material	
<ul style="list-style-type: none"> • Top • Inlay • Antenna • Bottom 	<ul style="list-style-type: none"> • PET plastic (label material) • PET plastic (carrier material) • Aluminum • Double-sided transfer adhesive on silicon paper
Color	White
Mounting	Single-sided adhesive (self-adhesive label)
Imprinting	Yes, (heat transfer method)
<ul style="list-style-type: none"> • Ambient temperature during operation • Storage temperature 	<ul style="list-style-type: none"> • -25 °C to +85 °C • +20 °C to +30 °C (the storage period is 2 years, determined by durability of the adhesive)

5.7.4 Dimension drawing

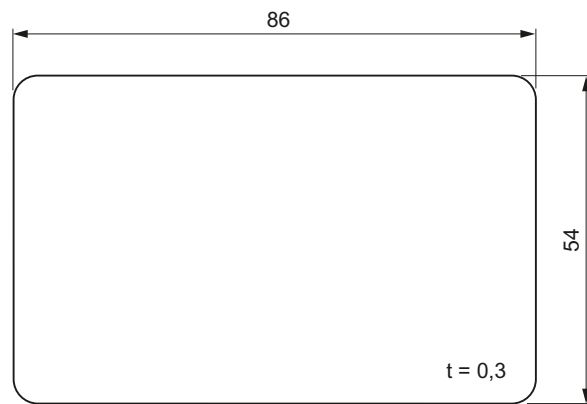

Dimensions in mm

Figure 5-15 Dimension drawing of MDS D165

5.8 MDS D200

5.8.1 Features

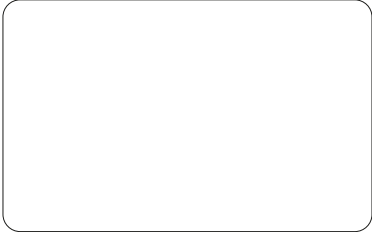
MDS D200 (special version)	Features	
	Application area	From simple identification such as electronic barcode replacement/supplementation, through warehouse and distribution logistics, right up to product identification.
	Memory	256-byte user memory
	Read/write range	See Chapter Field data (Page 33).
	Mounting on metal	Recommended distance from metal \geq 30 mm
	ISO standard	15693 with Tag-it HFI technology

5.8.2 Ordering data

Table 5- 12 Ordering data for MDS D200

	Order No.
MDS D200 (special version ISO-CARD)	6GT2600-1AD00-0AX0

5.8.3 Mounting on metal

Mounting on metal

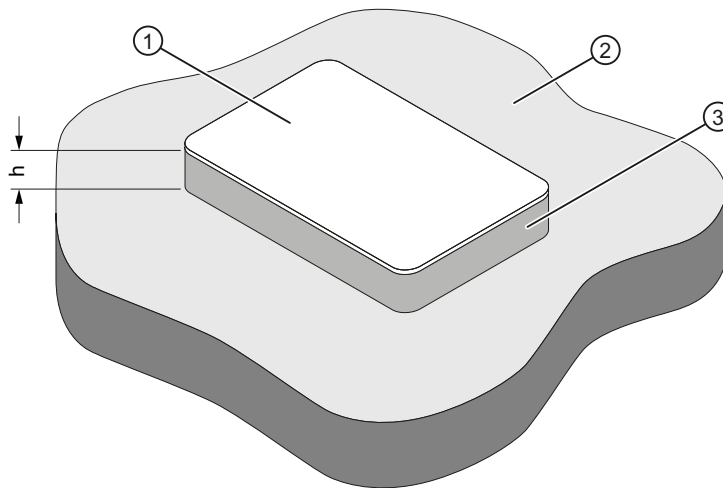

- h \geq 20 mm
- ① Data memory
- ② Metal
- ③ Non-metal

Figure 5-16 Mounting of the MDS D200 on metal with spacer

Flush-mounting

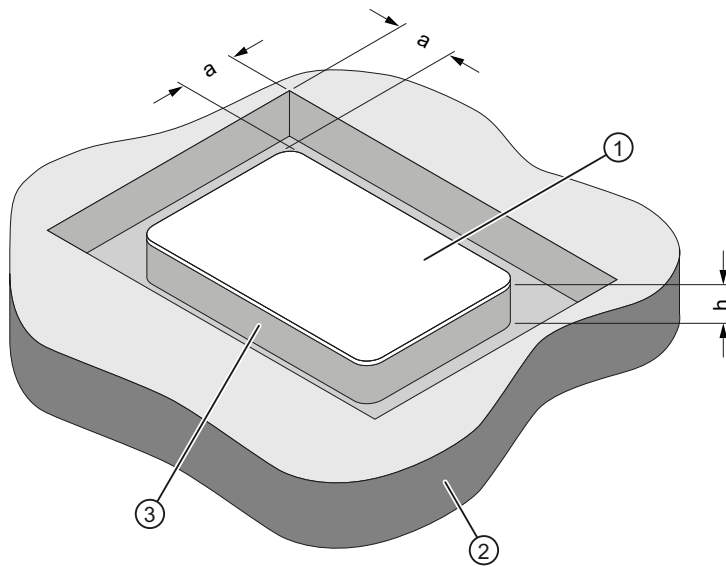

- a ≥ 20 mm
- h ≥ 20 mm
- ① Data memory
- ② Metal
- ③ Non-metal

Figure 5-17 Flush-mounting of MDS D200 in metal with spacer

Note

If the minimum guide values (h) are not observed, a reduction of the field data results.

5.8.4 Technical data

Memory configuration	<ul style="list-style-type: none"> • Serial number • Application memory 	<ul style="list-style-type: none"> • 8 bytes (fixed code) • 256 bytes
Storage technology	EEPROM	
Memory organization	4 bytes, block by block	
Protocol	according to ISO 15693	
Data retention (at +25 °C)	10 years	
MTBF (at +25 °C)	2 x 105 hours	
<ul style="list-style-type: none"> • Read cycles • Write cycles, min. • Write cycles, typical 	<ul style="list-style-type: none"> • Unlimited • 100 000 • 1 000 000 	
Read/write distance (Sg)	See Chapter Field data (Page 33)	
Recommended distance to metal	25 mm (approx. 30% reduction of the field data)	
Multitag capability	Yes	
Power supply	Inductive power transmission (without battery)	
Degree of protection according to EN 60529	IP67	
Vibration	ISO 10373/ISO 7810	
Torsion and bending load	ISO 10373/ISO 7816-1	
Mechanical design	Laminated plastic card, printable on both sides	
<ul style="list-style-type: none"> • Color • Material • Dimensions (L x W x H in mm) 	<ul style="list-style-type: none"> • White • PET • 85 x 54 x 0.8 	
Mounting	Adhesive, fixing lug	
Ambient temperature		
<ul style="list-style-type: none"> • Operation • Transport and storage 	<ul style="list-style-type: none"> • -20 °C to +60 °C • -20 °C to +60 °C 	
Weight	approx. 5 g	

5.8.5 Dimension drawing

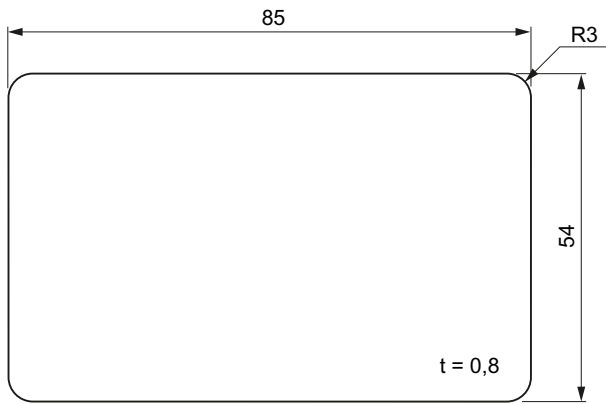

Dimensions in mm

Figure 5-18 Dimension drawing of MDS D200

5.9 MDS D261

5.9.1 Features

MDS D261 (special version)	Features	
	Application area	The design of the transponder (self-adhesive label) permits a variety of designs, guaranteeing optimum dimensioning for the widest variety of applications. From simple identification such as electronic barcode replacement/supplementation, through warehouse and distribution logistics, right up to product identification.
	Memory	256-byte user memory
	Read/write range	See Chapter Field data (Page 33).
	ISO standard	15693 with Tag-it HFI technology.

5.9.2 Ordering data

Table 5- 13 Ordering data for MDS D261

	Order No.
MDS D261	6GT2600-1AA00-0AX0

Type of delivery

Minimum order quantity: 1250 units (5 rolls with 250 units each)

5.9.3 Technical data

Memory configuration	<ul style="list-style-type: none"> • Serial number • AFI/DSFID • Application memory 	<ul style="list-style-type: none"> • 8 bytes (fixed code) • 2 bytes • 256 bytes
Storage technology	EEPROM	
Memory organization	4 bytes, block by block	
Protocol	according to ISO 15693	
Data transmission rate	<ul style="list-style-type: none"> • reading • writing 	<ul style="list-style-type: none"> • approx. 3.5 ms/byte • approx. 9.5 ms/byte
Multitag capability	Yes	
Data retention	10 years	
Read cycles	Unlimited	
Write cycles, min.	100 000	
Recommended distance to metal	25 mm (approx. 30% reduction of the field data)	
Power supply	Inductive power transmission (without battery)	
Typical read/write distance	See Chapter Field data (Page 33)	
Degree of protection according to EN 60529	IP65	
Dimensions	<ul style="list-style-type: none"> • L x W (in mm) • Height 	<ul style="list-style-type: none"> • 55 x 55 • approx. 0.3 mm
Material	<ul style="list-style-type: none"> • Top • Inlay • Antenna • Bottom 	<ul style="list-style-type: none"> • PET plastic (label material) • PET plastic (carrier material) • Aluminum • Double-sided transfer adhesive on silicon paper
Color	White	
Mounting	Single-sided adhesive (self-adhesive label)	
Imprinting	Yes (heat transfer method)	
	<ul style="list-style-type: none"> • Ambient temperature during operation • Storage temperature 	<ul style="list-style-type: none"> • -25 °C to +85 °C • +20 °C to +30 °C (the storage period is 2 years, determined by durability of the adhesive)
Type of delivery	Minimum order quantity 1250 units (5 rolls with 250 units each)	

5.9.4 Dimension drawing

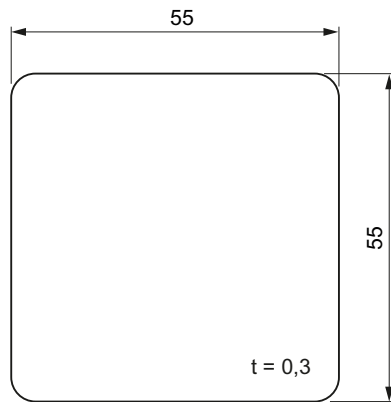

Dimensions in mm

Figure 5-19 Dimension drawing of MDS D261

5.10 MDS D324

5.10.1 Characteristics

MDS D324	Characteristics	
	Field of application	Production and distribution logistics and product identification
	Memory	EEPROM 1024 bytes gross 992 bytes net capacity
	Read/write range	See Chapter Field data (Page 33).
	Mounting on metal	Not possible: Recommended distance from metal ≥ 25 mm
	High resistance	Can also be used in harsh environments under extreme environmental conditions (e.g. with higher temperature load).
	ISO standard	ISO 15693

5.10.2 Ordering data

Table 5- 14 Ordering data MDS D324

	Order number
MDS D324	6GT2600-3AC00

5.10.3 Metal-free area

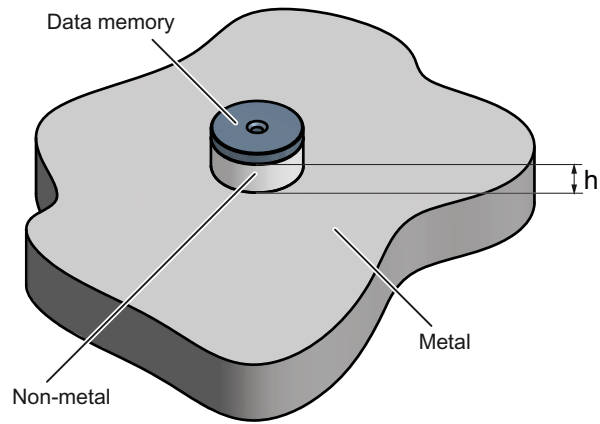

$h \geq 25 \text{ mm}$

Figure 5-20 Mounting of the MDS D324 on metal with spacer

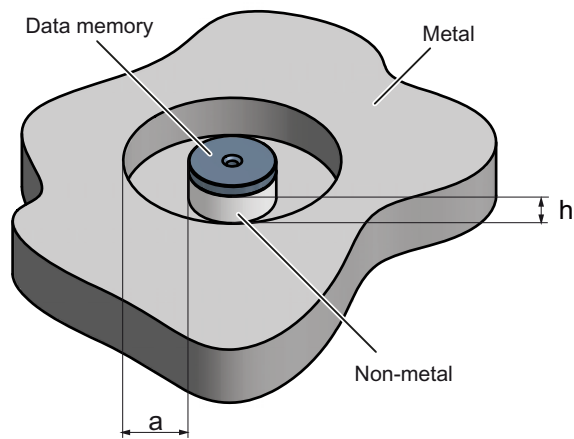

$h \geq 25 \text{ mm}$

$a \geq 25 \text{ mm}$

Figure 5-21 Flush-mounting of MDS D324 in metal with spacer

Note

If the minimum guide values (h) are not observed, a reduction of the field data results. It is possible to mount the MDS with metal screws (M3 countersunk head screws). This has no tangible impact on the range.

5.10.4 Technical specifications

Table 5- 15 Technical data MDS D324

Memory size	1024 bytes
Memory configuration	<ul style="list-style-type: none"> • Serial number • Configuration memory • Manufacturer data
	<ul style="list-style-type: none"> • 8 bytes (fixed code) • 1008 bytes • 8 bytes
Storage technology	EEPROM
Memory organization	1024 EEPROM/gross 992 net capacity When using the OPT area, 16 bytes of it must be subtracted in 4 byte blocks
Protocol	according to ISO 15693
Data retention (at +40 °C)	10 years
MTBF (at +40 °C)	≥ 1.5 x 10 ⁶ hours
Read cycles	Unlimited
Write cycles, typical	1 000 000
Write cycles, min.	100 000
Read/write distance (S ₉)	See Chapter
Distance from metal	Min. 25 mm (approx. 30% reduction of the field data)
Multitag capability	Yes
Anti-collision speed	Approx. 20 transponders/s simultaneously identifiable
Power supply	Inductive power transmission (without battery)
Degree of protection to EN 60529	IP67
Shock resistant to EN 60721-3-7, Class 7M3 total shock response spectrum, type II	100 g
Vibration-resistant to EN 60721-3-7, Class 7M3	20 g
Torsion and bending load	Not permissible
Enclosure	<ul style="list-style-type: none"> • Dimensions (D x H) in mm • Color • Material
	<ul style="list-style-type: none"> • 27(±0,2) x 4(±0.2) • Black • Epoxy casting resin
Fixing	Adhesive, M3 screw
Tightening torque at +20 °C	≤ 1 Nm (at high temperatures, the expansion coefficients of the materials used must be taken into account)

Ambient temperature	
• Operation	• -25 °C to +125 °C
• During transportation and storage	• -40 °C to +150 °C
Weight, ca.	5 g

5.10.5 Dimension drawing

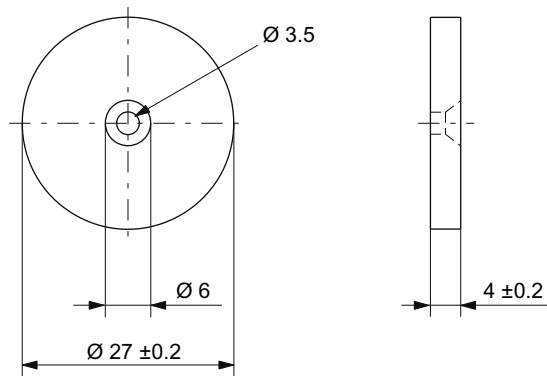

Dimensions in mm

Figure 5-22 Dimension drawing of MDS D324

5.11 MDS D424

5.11.1 Characteristics

MDS D424	Characteristics	
	Field of application	Production and distribution logistics as well as in assembly and production lines
	Memory	FRAM 2048 bytes gross 2000 bytes net
	Read/write range	See Chapter Field data (Page 33).
	Mounting on metal	Not possible: Recommended distance from metal ≥ 25 mm
	High resistance	Can also be used in a harsh industrial environment without problem
	Standard	Oriented according to ISO standard 15693

5.11.2 Ordering data

Table 5- 16 Ordering data of MDS D424

	Order number
MDS D424	6GT2600-4AC00

5.11.3 Mounting on metal

Mounting on metal

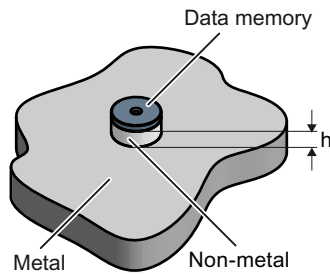

$h \geq 25$ mm

Figure 5-23 Mounting of the MDS D424 on metal with spacer

Flush-mounting

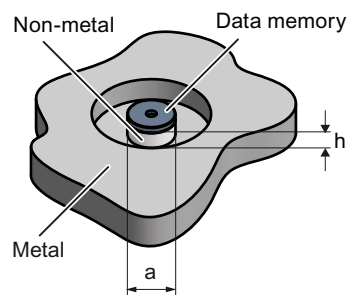

$h \geq 25 \text{ mm}$

$a \geq 25 \text{ mm}$

Figure 5-24 Flush-mounting of MDS D424 in metal with spacer

Note

If the minimum guide values (h) are not observed, a reduction of the field data results. It is possible to mount the MDS with metal screws (M3 countersunk head screws). This has no tangible impact on the range.

5.11.4 Technical specifications

Table 5- 17 Technical data of MDS D424

Memory size	2048 bytes
Memory configuration	<ul style="list-style-type: none"> • Serial number • 8 bytes (fixed code) • Configuration memory • 40 bytes • Application memory • 2000 bytes
Storage technology	FRAM
Memory organization	2048 bytes gross 2000 bytes net
Protocol	ISO 15693
Data retention (at +40 °C)	10 years
MTBF (at +40 °C)	≥ 1.5 x 10 ⁶ hours
Read cycles	Unlimited
Write cycles (at +40 °C)	> 10 ¹⁰
Read/write distance (S _g)	See Chapter Field data (Page 33)
Distance from metal	Min. 25 mm (ca. 30% reduction of the field data)
Multitag capability	Yes
Power supply	Inductive power transmission (without battery)
Degree of protection to EN 60529	IP67
Shock according to EN 60721-3-7, Class 7M3 Total shock response spectrum, Type II	100 g ¹⁾
Vibration-resistant to EN 60721-3-7, Class 7M3	20 g ¹⁾
Torsion and bending load	Not permissible
Enclosure	<ul style="list-style-type: none"> • Color • Black • Material • Epoxy casting resin • Dimensions (D x H) in mm • 27(±0.2) x 4(±0.2)
Fixing	M3 screw, adhesive
Tightening torque at +20 °C	≤ 1 Nm
Ambient temperature	<ul style="list-style-type: none"> • During operation • -25 °C to +85 °C • Transport and storage • -40 °C to +100 °C
Weight, approx.	5 g

¹⁾ The values for shock and vibration are maximum values and must not be applied continuously.

5.11.5 Dimension drawing

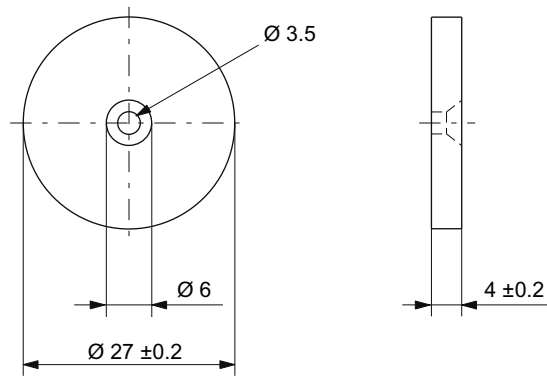

Dimensions in mm

Figure 5-25 Dimension drawing of MDS D424

5.12 MDS D428

5.12.1 Characteristics

MDS D428	Characteristics	
	Field of application	Compact and rugged ISO transponder; suitable for screw mounting Use in assembly and production lines in the powertrain sector
	Memory	FRAM 2048 bytes gross 2000 bytes net
	Read/write range	See Chapter Field data (Page 33).
	Mounting on metal	Yes
	High resistance	Rugged packaging of the MDS D428; can therefore also be used under extreme environmental conditions without problem
	Standard	Oriented according to ISO-15693

5.12.2 Ordering data

Table 5- 18 Ordering data of MDS D428

	Order number
MDS D428	6GT2600-4AK00

5.12.3 Application example of MDS D428

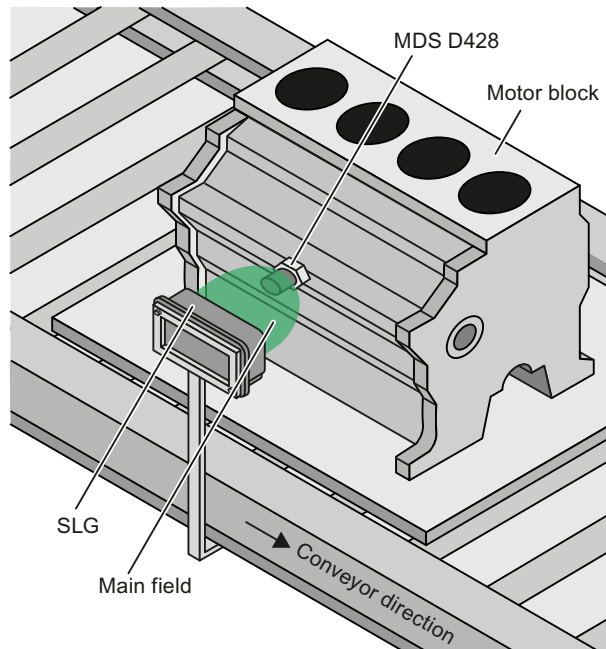

Figure 5-26 Application example

Table 5- 19 Field data MDS D428 - MOBY D-SLG

	SLG D10/D10S ANT D5	SLG D11/D11S ANT D5	SLG D12/D12S
Operating distance (Sa)	0...120	0...70	0...40
Limit distance (Sg)	160	100	60
Transmission window (Lx/Ly)	∅ 300	∅ 280	100 / 60
Minimum distance from MDS to MDS	≥ 800	≥ 800	≥ 300

All values are in mm

5.12.4 Technical specifications

Table 5- 20 Technical data of MDS D428

Memory size	2048 bytes
Memory configuration	<ul style="list-style-type: none"> • Serial number • Configuration memory • Application memory <ul style="list-style-type: none"> • 8 bytes (fixed code) • 40 bytes • 2000 bytes
Storage technology	FRAM
Memory organization	2048 bytes gross 2000 bytes net
Protocol	ISO 15693
Data retention (at +40 °C)	10 years
Bulk detection/multitag capability	Yes
Read cycles	Unlimited
Write cycles at +40 °C, typical	> 10 ¹⁰
Read/write distance (S _g)	See Chapter Field data (Page 33)
Distance from metal	Can be mounted on metal
Power supply	Inductive power transmission (without battery)
Degree of protection to EN 60529	IP68 ¹⁾ IPx9K ²⁾
Shock, tested in accordance with IEC 68-2-27	50 g ³⁾
Vibration, tested in accordance with IEC 68-2-6	20 g ³⁾
Torsion and bending load	Not permissible
Enclosure	<ul style="list-style-type: none"> • Color • Material <ul style="list-style-type: none"> • Black • Plastic PA 6.6 GF; thread: Stainless steel <ul style="list-style-type: none"> • Dimensions (D x H) in mm <ul style="list-style-type: none"> • 18(±1) x 20(±1) (without thread), thread M8
MDS fixing	Screws, tightening torque (at room temperature) ≤ 1 Nm
Ambient temperature	<ul style="list-style-type: none"> • During operation • Transport and storage <ul style="list-style-type: none"> • -25 °C to +85 °C • -40 °C to +125 °C
Weight, approx.	35 g

¹⁾ 2 hours, 2 m, +20 °C

²⁾ steam jet: 150 mm; 10 to 15 l/min; 100 bar; 75 °C

³⁾ The values for shock and vibration are maximum values and must not be applied continuously.

Note

It is recommended that a test is performed in critical applications.

5.12.5 Dimension drawing

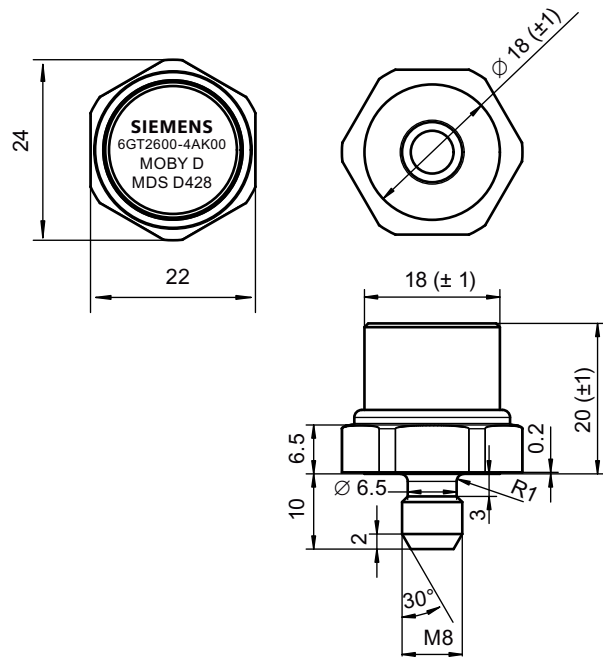

Dimensions in mm

Figure 5-27 Dimension drawing of MDS D428

5.13 MDS D460

5.13.1 Characteristics

MDS D460	Characteristics	
	Field of application	Identification in small assembly lines
	Memory	FRAM 2048 bytes gross 2000 bytes net
	Read/write range	See Chapter Field data (Page 33).
	Mounting on metal	Not possible: Recommended distance from metal ≥ 25 mm
	High resistance	Can also be used in a harsh industrial environment
	Standard	Oriented according to ISO standard 15693

5.13.2 Ordering data

Table 5- 21 Ordering data of MDS D460

	Order number
MDS D460	6GT2600-4AB00

5.13.3 Mounting on metal

Mounting on metal

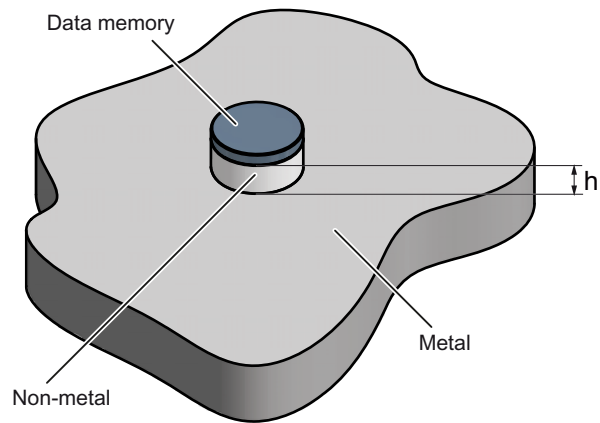

$h \geq 25 \text{ mm}$

Figure 5-28 Mounting of the MDS D460 on metal with spacer

Note

If the minimum guide values (h) are not observed, a reduction of the field data results. In critical applications, it is recommended that a test is performed.

Flush-mounting

Flush-mounting of the MDS D460 in metal is not permitted!

5.13.4 Technical specifications

Memory size	2048 bytes
Memory configuration	
<ul style="list-style-type: none"> • Serial number • Configuration memory • Application memory 	<ul style="list-style-type: none"> • 8 bytes (fixed code) • 40 bytes • 2000 bytes
Storage technology	FRAM
Memory organization	2048 bytes gross 2000 bytes net
Protocol	ISO 15693
Data retention (at +40 °C)	10 years
MTBF (at +40 °C)	2 x 10 ⁶ hours
Bulk detection/multitag capability	Yes
Read cycles	Unlimited
Write cycles (at +40 °C, typical)	> 10 ¹⁰
Read/write distance (S _g)	See Chapter Field data (Page 33)
Distance from metal	Min. 15 mm (ca. 20% reduction of the field data)
Power supply	Inductive power transmission (without battery)
Degree of protection to EN 60529	IP67 IPx9K ¹⁾
Shock, tested in accordance with IEC 68-2-27	50 g ²⁾
Vibration, tested in accordance with IEC 68-2-6	20 g ²⁾
Torsion and bending load	Not permissible
Enclosure	
<ul style="list-style-type: none"> • Color • Material • Dimensions (D x H) in mm 	<ul style="list-style-type: none"> • Black • Epoxy casting resin • 16(±0.2) x 3,0(±0.2)
MDS fixing	Adhesion, spacer
Ambient temperature	
<ul style="list-style-type: none"> • During operation • Transport and storage 	<ul style="list-style-type: none"> • -25 °C to +85 °C permanent • -40 °C to +100 °C
Weight, approx.	3 g

¹⁾ steam jet: 150 mm; 10 to 15 l/min; 100 bar; 75 °C

²⁾ The values for shock and vibration are maximum values and must not be applied continuously.

5.13.5 Dimension drawing

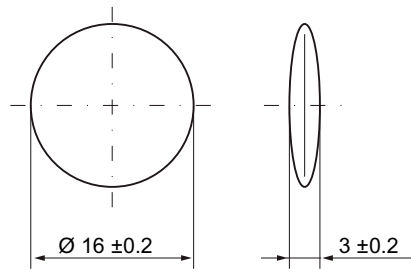

Dimensions in mm

Figure 5-29 Dimension drawing of MDS D460

Write/read devices with RS232 interface

6.1 Overview of SLG with RS 232 serial interface

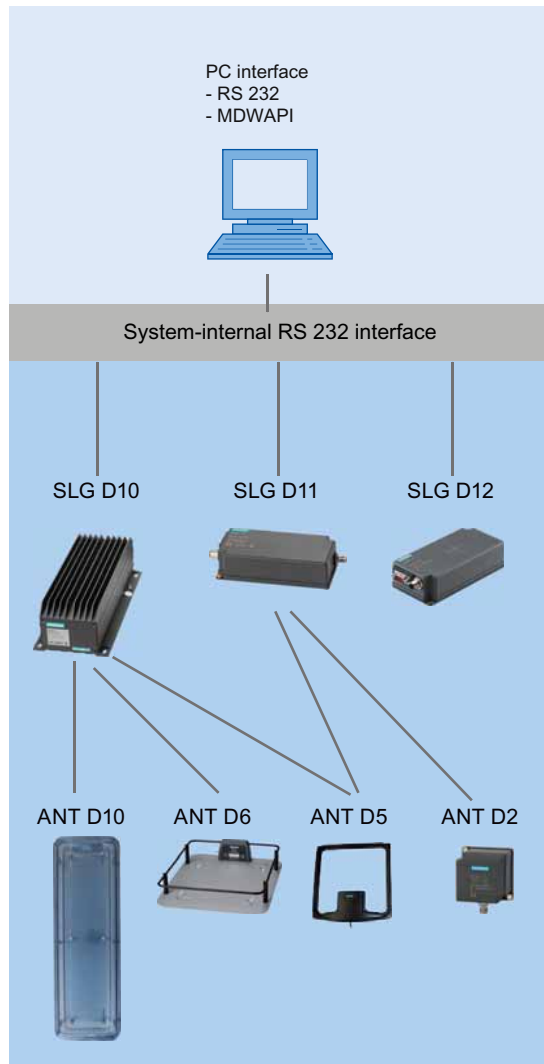

Figure 6-1 Write/read devices with RS232 interface

Application area

The SLG with the serial RS 232 interface provides the communications interface between almost any higher-level computer systems, PCs and the mobile data storage unit (MDS).

6.1 Overview of SLG with RS 232 serial interface

The following variants are available in accordance with customer requirements:

- SLG D10 with
 - ANT D5
 - ANT D6
 - ANT D10
- SLG D11 with
 - ANT D2
 - ANT D5
- SLG D12 with integral antenna

The rugged housing and high degree of protection (IP65) permit use even under the toughest industrial conditions.

Design and function

The SLG is connected over a serial interface (RS 232) of the PC that supports communication with PCs or non-Siemens PLCs. Commands and the data to be written or read must be converted through an appropriate modulator/demodulator circuit.

The transmittable quantity of information between SLG and MDS depends on:

- The speed at which the MDS moves through the transmission window (determined by the antenna) of the SLG
- The length of the transmission window

Use of the C++ library supports rapid programming of the SLG using applications executing under Windows 9x/2000, NT 4.0 and XP.

Table 6- 1 Overview of SLG with RS 232 serial interface

SLG with ANT		Operating distance S_a (depending on MDS)	Limit distance S_g (depending on MDS)	Temperature range (during operation)	SLG dimensions (L x W x H) in mm	Antenna dimensions (L x W x H) in mm	Degree of protection
SLG D10	ANT D5	0 to 400 mm	480 mm	-20 to +55 °C	320 x 145 x 100	340 x 325 x 38	IP65
	ANT D6	0 to 550 mm	650 mm	-20 to +55 °C	320 x 145 x 100	580 x 480 x 110	IP65
	ANT D10	0 to 400 mm	480 mm	-20 to +55 °C	320 x 145 x 100	1150 x 365 x 115	IP65
SLG D11	ANT D2	35 to 70 mm	90 mm	-20 to +70 °C	160 x 80 x 40	75 x 75 x 40	IP65
	ANT D5	0 to 300 mm	380 mm	-20 to +55 °C	160 x 80 x 40	340 x 325 x 38	IP65
SLG D12		0 to 120 mm	160 mm	-20 to +55 °C	160 x 80 x 40	-	IP65

Definition of IP65:

- Protection against the ingress of dust (dustproof)
- Complete touch protection
- Protection against water jets

Configuration SLG - MDS (over RS 232)

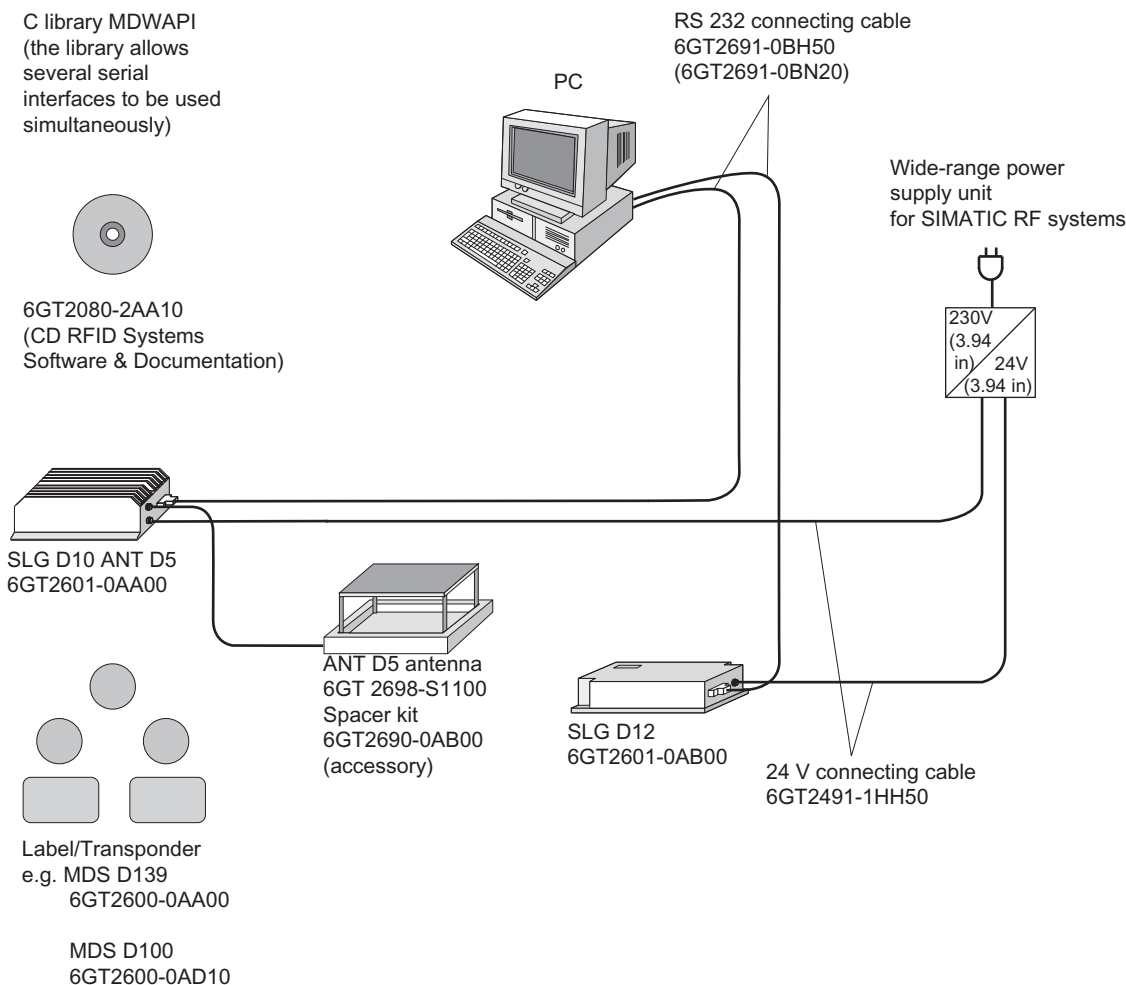

Figure 6-2 Configuration SLG - MDS over RS 232

Programming of SLG D10, SLG D11 and SLG D12

Communication is performed on the serial interface between the SLG and the higher-level computer system (host) by means of an asynchronous 8 bit binary protocol. The message frames are protected by means of a CRC 16.

Executable on PCs equipped with Pentium 2 processor and higher with a serial interface and a Windows 9x/2000/NT 4.0/XP operating system.

The SLG is connected to a serial interface of the computer. Users work with the PC interfaces COM 1 and/or COM 2; further interfaces can be operated with additional hardware.

For programming, a 32 bit library (MDWAPI for Windows 9x / 2000, NT 4.0I and XP) and programming guide are available to the user on the CD *RFID Systems Software & Documentation*.

For computers that are not used under Windows (e.g. UNIX), the communication procedure is described in the programming guide (MDWAPI).

Default parameters

The configuration parameters are described in the programming guide (MDWAPI).

Table 6-2 Ordering data for CD RFID Systems Software & Documentation

Product	Order No.
CD <i>RFID Systems Software & Documentation</i>	6GT2080-2AA10

Note

About MOBY software and licensing

When purchasing an interface module or SLG, neither software nor documentation is supplied. The *CD RFID Systems Software & Documentation* contains all available FBs/FCs for SIMATIC, C libraries for Windows Professional, demo programs, etc. and **needs to be ordered separately**.

In addition, the CD-ROM contains the complete MOBY documentation (German, English and some French) in PDF format. The purchase of an interface module or SLG includes a payment for the use of the software, including documentation, on the *CD RFID Systems Software & Documentation* and the purchaser acquires the right to make copies (copy license) insofar as they are required as part of the customer-specific application or development for the plant.

The enclosed contract pertaining to the use of software products against a one-off payment shall apply in addition.

6.2 SLG D10 basic unit

6.2.1 Features

SLG D10	Features	
	Performance range	The SLG D10 is a basic unit in the high-end range with a serial interface.
	Interface	RS232 serial interface
	Range	up to 650 mm (depends on antenna)
	Communication	with a PC or third-party controllers
	Connectable antennas	<ul style="list-style-type: none"> • ANT D5 • ANT D6 • ANT D10 (2 to 4 antennas can be connected via an antenna duplexer)
	Programming options	via C library, Windows 9x, 2000, NT or XP required
	Degree of protection	IP65
	Multitag capability	Yes

6.2.2 Ordering data

Table 6- 3 Ordering data for SLG D10

SLG D10	Order No.
SLG D10 basic unit without antenna; with RS 232 serial interface for standard PC	6GT2698-1AA00

Table 6- 4 Ordering data for SLG D10 accessories

SLG D10 accessories	Order No.	
24 V connecting cable	Length 5 m	6GT2491-1HH50
RS232 cable	Length 5 m	6GT2691-0BH50
	Length 20 m	6GT2691-0BN20
Wide-range power supply unit for SIMATIC RF systems (100...240 V AC / 24 V DC / 3 A) with 2 m plug-in cable with country-specific connector. For further information, see Chapter Wide-range power supply unit for SIMATIC RF systems (Page 267)	EU	6GT2898-0AA00
	UK	6GT2898-0AA10
	US	6GT2698-0AA20

6.2.3 Technical data

Table 6- 5 Technical data for SLG D10 basic unit

Inductive interface to the MDS	
Transmission frequency	13.56 MHz
Transponders supported	Transponders according to ISO 15693 and I-Code1
Serial interface to the user	
Transmission protocol	RS 232 (RS 422 on request)
Data transmission rate	Asynchronous 8 bit
Data backup	9600 baud to 115.2 Kbaud (adjustable)
Transmit power	CRC 16
Write/read distances SLG - MDS	up to 10 W
Software functions	650 mm typically (see field data)
Programming	Read, write, initialize MDS, access rights, multitag
Multitag	Windows 9x, 2000, NT, XP with 32 bit DLL available
Anti-collision speed	Yes
Power supply	
Current consumption	approx. 20 labels/s simultaneously identifiable
<ul style="list-style-type: none"> • Operation • Inrush current, momentary 	<ul style="list-style-type: none"> • up to 1.4 A • 2.8 A/50 ms
Cable lengths	
<ul style="list-style-type: none"> • With RS 232 	<ul style="list-style-type: none"> • 30 m (depending on baud rate)
Digital inputs/outputs	None
Enclosure dimensions (L x W x H) in mm	320 x 145 x 100 (without connector)
Color	Anthracite
Material	Aluminum
Connector	
<ul style="list-style-type: none"> • Antenna • V24 interface • Power supply 	<ul style="list-style-type: none"> • TNC connector • 9-pin Sub-D connector (male) • 4-pin M12 connector (male)
Mounting	4 x M6 screws
Ambient temperature	
<ul style="list-style-type: none"> • Operation • Transport and storage 	<ul style="list-style-type: none"> • -20 °C to +55 °C • -25 °C to +70 °C
MTBF	7.5 x 10 ⁴ hours
Degree of protection according to EN 60529	IP65 (UL: for indoor use only)
Shock resistant according to EN 60721-3-7 Class 7M2	30 g
Total shock response spectrum Type II	

Vibration according to EN 60721-3-7 Class 7M2	1 g (9 to 200 Hz)/ 1.5 g (200 to 500 Hz)
Weight, approx.	3500 g
Approvals	<ul style="list-style-type: none">• CE• FCC• IC• UL 60950• Harmless to heart pacemakers

6.2.4 FCC information

Siemens MOBY D SLG D10

FCC ID: NXW-MOBYD-SLGD10

This device complies with Part 15 of the FCC Rules. Operation is subject to the following two conditions:

- (1) This device may not cause harmful interference, and
- (2) This device must accept any interference that may cause undesired operation.

Note

The manufacturer is not responsible for any radio or TV interference caused by unauthorized changes and modifications to this equipment:

Such modifications could void the user's authority to operate the equipment.

6.2.5 Dimension drawing

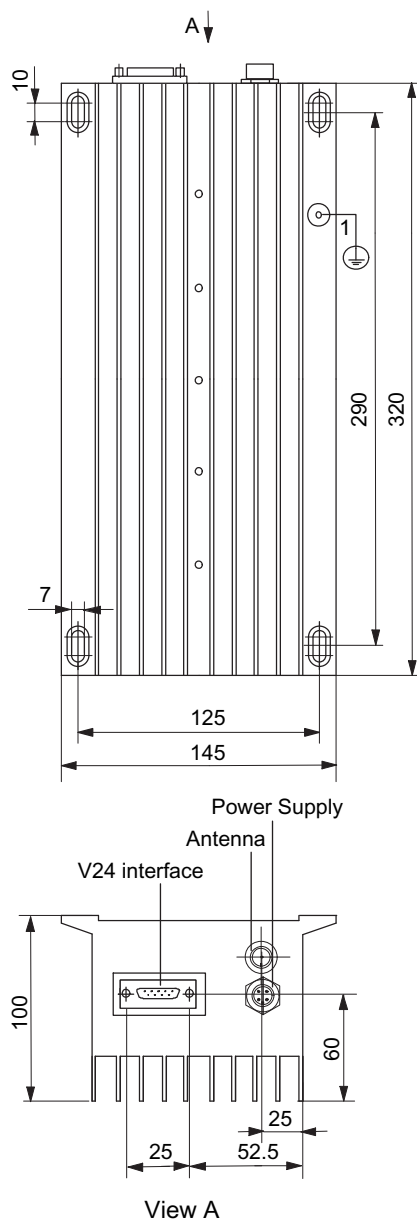

Note:
The SLG must be grounded on grounding screw 1.

Dimensions in mm

Figure 6-3 Dimension drawing of SLG D10 basic unit

6.3 SLG D11 basic unit

6.3.1 Features

SLG D11	Features	
	Performance range	The SLG D11 is a basic unit in the medium performance range with a serial interface.
	Interface	RS232 serial interface
	Communication	with a PC or third-party controllers
	Connectable antennas	<ul style="list-style-type: none"> • ANT D2 • ANT D5
	Programming options	via a C library, Windows 9x, 2000, NT or XP required
	Degree of protection	IP65
	Multitag capability	Yes

6.3.2 Ordering data

Table 6- 6 SLG D11 ordering data

SLG D11	Order No.
SLG D11 without antenna; with RS232 serial interface for standard PC	6GT2698-1AC00

Table 6- 7 SLG D11 accessories ordering data

SLG D11 accessories	Order No.	
Wide-range power supply unit for SIMATIC RF systems (100 - 240 V AC / 24 V DC / 3 A) with 2 m connecting cable and country-specific plug.	EU	6GT2898-0AA00
	UK	6GT2898-0AA10
	US	6GT2698-0AA20
24 V connecting cable,	Length 5 m	6GT2491-1HH50
RS232 cable	Length 5 m	6GT2691-0BH50
	Length 20 m	6GT2691-0BN20

6.3.3 Technical specifications

Table 6- 8 Technical data of SLG D11

Inductive interface to the MDS	
Transmission frequency	13.56 MHz
Transponders supported	Transponders to ISO 15693 and I-Code1
Serial interface to the user	RS 232
Transmission protocol	Asynchronous 8 bit
Data transmission rate	9600 baud to 38.4 Kbaud (adjustable)
Data backup	CRC 16
Transmit power	1 W
Write/read distances SLG - MDS	See
Software functions	Read, write, initialize MDS, access rights
Programming	Windows 9x, 2000, NT and XP, with 32 bit DLL available
Multitag	Yes
Anti-collision speed	approx. 20 labels/s simultaneously identifiable
Power supply	
• Rated value	• --- DC 24 V
• Permitted range	• --- DC 20 V ... 30 V (--- DC 24 V ± 5 % UL only)
Current consumption	
• Operation	• 200 mA
• Inrush current, momentary	• 600 mA
Cable length, SLG - PC	
• With RS 232	• Max. 30 m
Digital inputs/outputs	None
Dimensions (L x W x H) in mm	160 x 80 x 40 without connector
Color	Anthracite
Material	Plastic PA 12
Connectors	
• Antenna (plugs into SLG)	• TNC connector
• V24 interface	• 9-pin Sub-D connector (male)
• Power supply	• 4-pin M12 connector (male)
SLG fixing	2 x M5 screws
Tightening torque (at room temperature)	≤ 2 Nm
Ambient temperature	
• Operation	• -25 °C to +55 °C
• Transport and storage	• -25 °C to +70 °C
MTBF	2.0 x 10 ⁵ hours
Degree of protection to EN 60529	IP65 (UL: for indoor only)

Shock resistant to EN 60721-3-7 Class 7M2 Total shock response spectrum Type II	30 g
Vibration resistance in accordance with EN 60721-3-7, Class 7M2	1 g (9 to 200 Hz)/1.5 g (200 to 500 Hz)
Weight, approx.	600 g
Approvals	<ul style="list-style-type: none">• CE• FCC• IC• Harmless to heart pacemakers• UL 60950

6.3.4 FCC information

Siemens MOBY D SLG D11

FCC ID: NXW-MOBYD-SLGD11

This device complies with Part 15 of the FCC Rules. Operation is subject to the following two conditions:

- (1) This device may not cause harmful interference, and
- (2) This device must accept any interference that may cause undesired operation.

Note

The manufacturer is not responsible for any radio or TV interference caused by unauthorized changes and modifications to this equipment:

Such modifications could void the user's authority to operate the equipment.

6.3.5 Dimension drawing

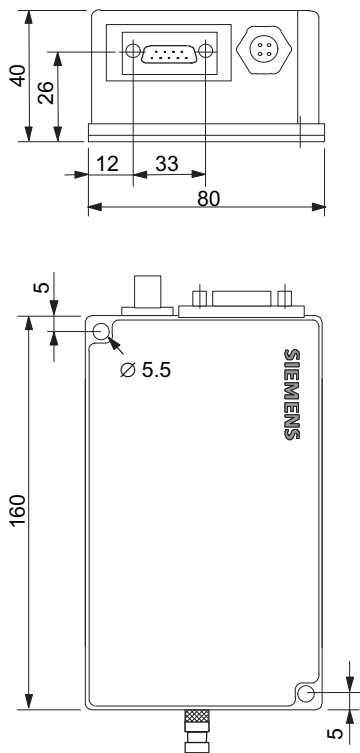

Dimensions in mm

Figure 6-4 Dimension drawing of the SLG D11

6.4 SLG D12

6.4.1 Features

SLG D12	Features	
	Performance range	The SLG D12 is a write/read device in the lower performance range with serial interface.
	Range	up to 160 mm
	Interface	RS232 serial interface
	Communication	with a PC or third-party controllers
	Antenna	integrated
	Programming options	via a C library, Windows 9x, 2000, NT or XP required
	Degree of protection	IP65
	Multitag capability	Yes

6.4.2 Ordering data

Table 6- 9 Ordering data for SLG D12

SLG D12	Order No.
SLG D12 with integral antenna; with RS 232 serial interface for standard PC,	6GT2601-0AB00

Table 6- 10 Ordering data for SLG D12 accessories

SLG D12 accessories	Order No.	
Wide-range power supply unit for SIMATIC RF systems (100...240 V AC/24 V DC/3 A) with 2 m plug-in cable with country-specific connector. For further information, see Section Wide-range power supply unit for SIMATIC RF systems (Page 267).	EU	6GT2898-0AA00
	UK	6GT2898-0AA10
	US	6GT2698-0AA20

6.4.3 Technical data

Table 6- 11 Technical data for SLG D12

Inductive interface to the MDS	
Transmission frequency	13.56 MHz
Transponders supported	Transponders according to ISO 15693 and I-Code1
Serial interface to the user	RS 232
Transmission protocol	Asynchronous 8 bit
Data transmission rate	9600 baud to 38.4 Kbaud (adjustable)
Data backup	CRC 16
Transmit power	1 W
Write/read distances SLG - MDS	160 mm typically (see field data)
Software functions	Read, write, initialize MDS, access rights, multitag
Programming	Windows 9x, 2000, NT and XP with 32 bit DLL available
Multitag	Yes
Anti-collision speed	approx. 20 labels/s simultaneously identifiable
Power supply	
• Rated value	• --- DC 24 V
• Permissible range	• --- DC 20 V ... 30 V (--- DC 24 V ± 5 % UL only)
Current consumption	
• Operation	• 150 mA
• Inrush current, momentary	• 600 mA
Cable length SLG – PC with RS 232	30 m
Digital inputs/outputs	None
Enclosure dimensions (L x W x H) in mm	160 x 80 x 40 (without connector)
Color	Anthracite
Material	Plastic PA 12
Connector	
• V24 interface	• 9-pin Sub-D connector (male)
• Power supply	• 4-pin M12 connector (male)
Mounting	2 x M5 screws
Ambient temperature	
• Operation	• -25 °C to +55 °C
• Transport and storage	• -25 °C to +70 °C
MTBF	2.0 x 10 ⁵ hours
Degree of protection according to EN 60529	IP65 (UL: for indoor use only)
Shock resistant according to EN 60721-3-7 Class 7M2	30 g
Total shock response spectrum Type II	
Vibration according to EN 60721-3-7 Class 7M2	1 g (9 to 200 Hz)/1.5 g (200 to 500 Hz)

Weight, approx.	500 g
Approvals	<ul style="list-style-type: none">• CE• FCC• IC• Harmless to heart pacemakers• UL 60950

Note

The SLG D12 can process up to 4 MDS with I-Code 1-Chip (e.g. MDS D139) in multitag mode!

6.4.4 FCC information

Siemens MOBY D SLG D12

FCC ID: NXW-MOBYD-SLGD12

This device complies with Part 15 of the FCC Rules. Operation is subject to the following two conditions:

- (1) This device may not cause harmful interference, and
- (2) This device must accept any interference that may cause undesired operation.

Note

The manufacturer is not responsible for any radio or TV interference caused by unauthorized changes and modifications to this equipment:

Such modifications could void the user's authority to operate the equipment.

6.4.5 Transmission window

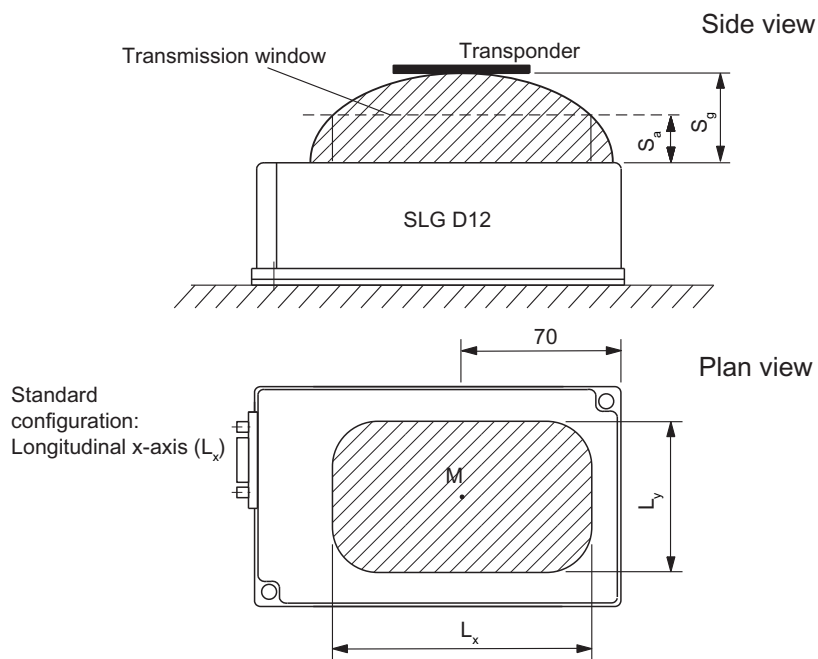

Lx 120 mm
Ly 60 mm

Figure 6-5 Transmission window for SLG D12

6.4.6 Secondary fields

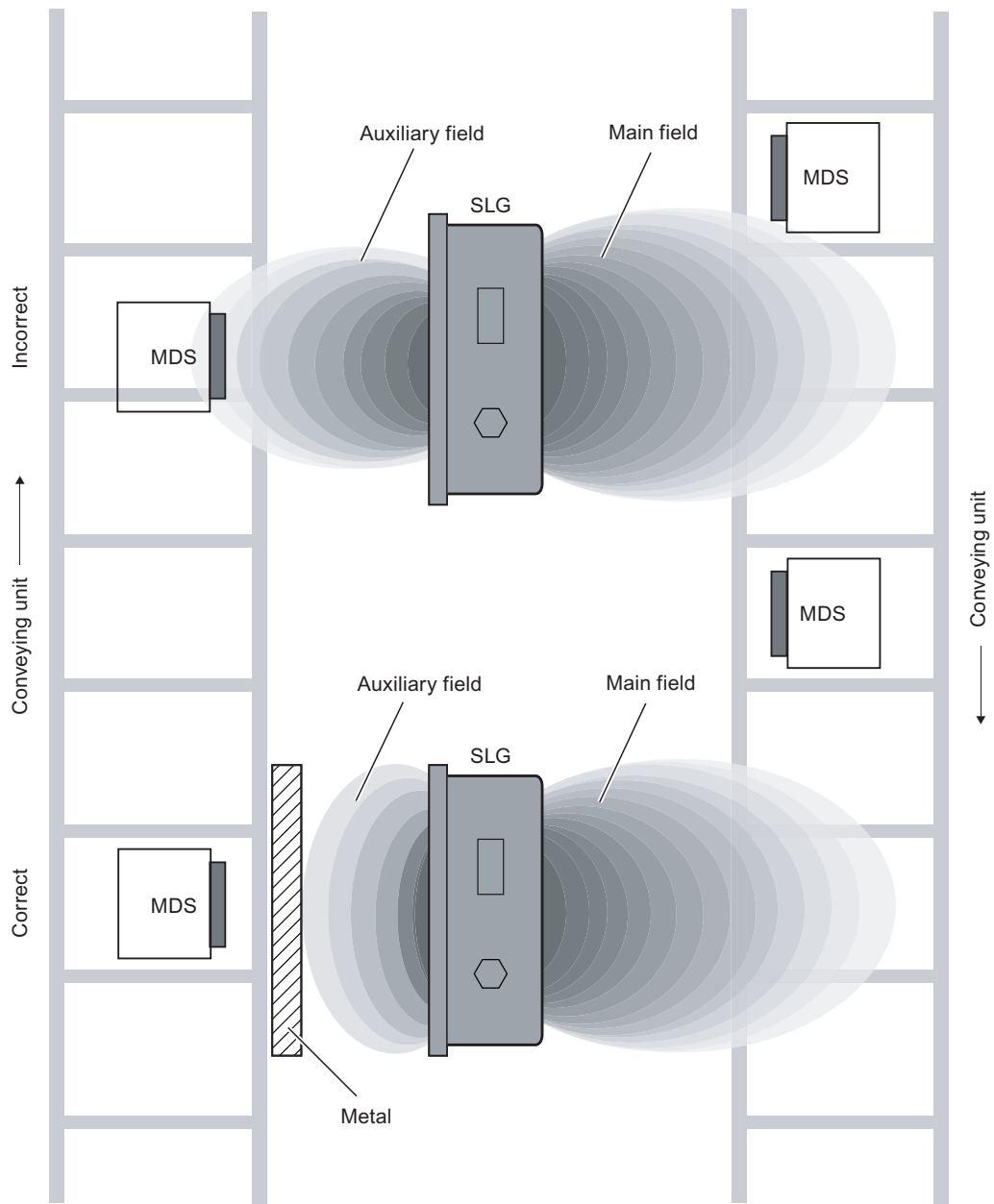

Figure 6-6 MDS shielding

To avoid undesired reading of the MDS outside the main field, the MDS must be shielded.

6.4.7 Influence of metal

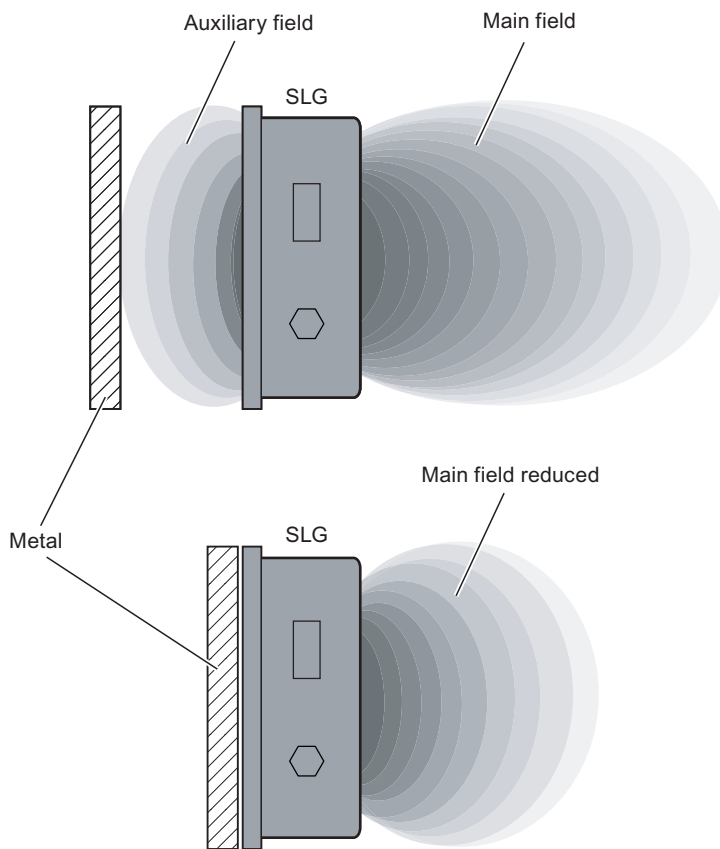

Figure 6-7 Reduction in range through influence of metal

6.4.8 Metal-free area

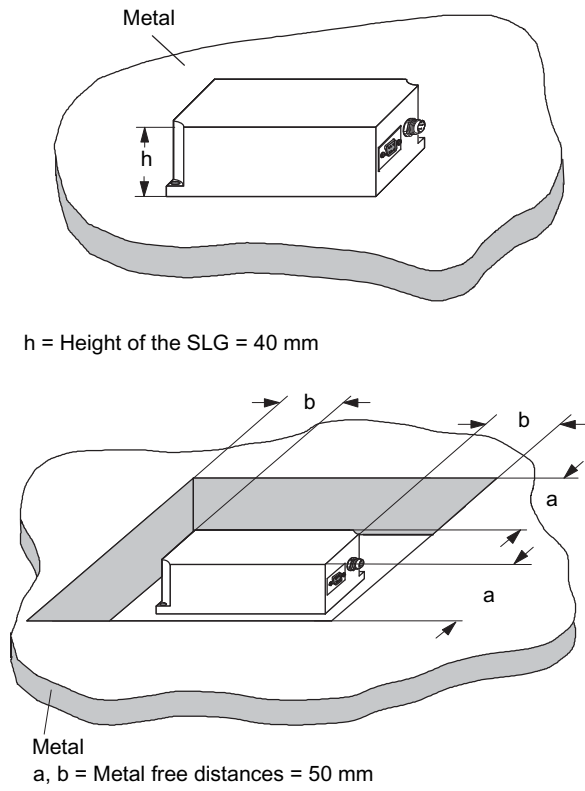
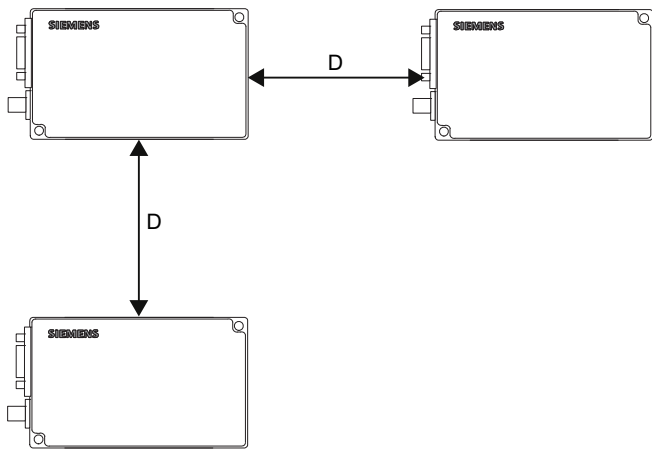

Figure 6-8 Metal-free area for SLG D12

6.4.9 Minimum distances between several SLGs

Definition of distance D



$D \geq 0.5 \text{ m}$

Figure 6-9 Distance D: SLG D12

6.4.10 Dimension drawing

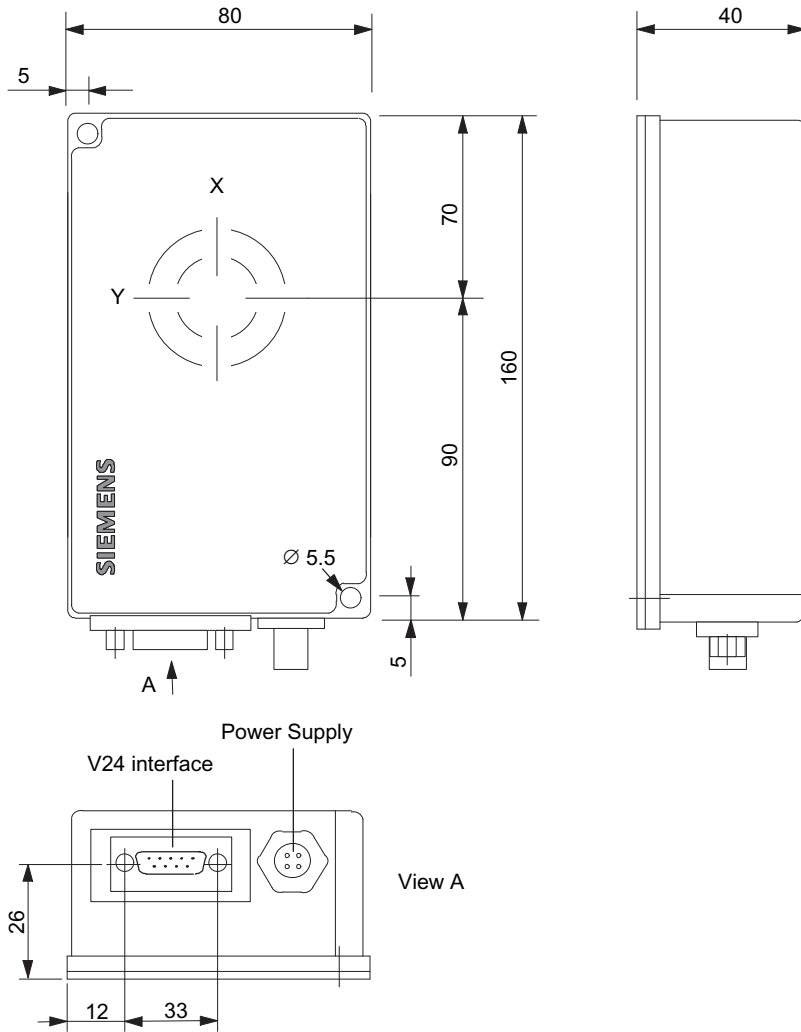

Dimensions in mm

Figure 6-10 Dimension drawing of SLG D12

Write/read devices with RS422 interface

7.1 Overview SLG with RS 422 for SIMATIC S7 and PROFIBUS DP-V1

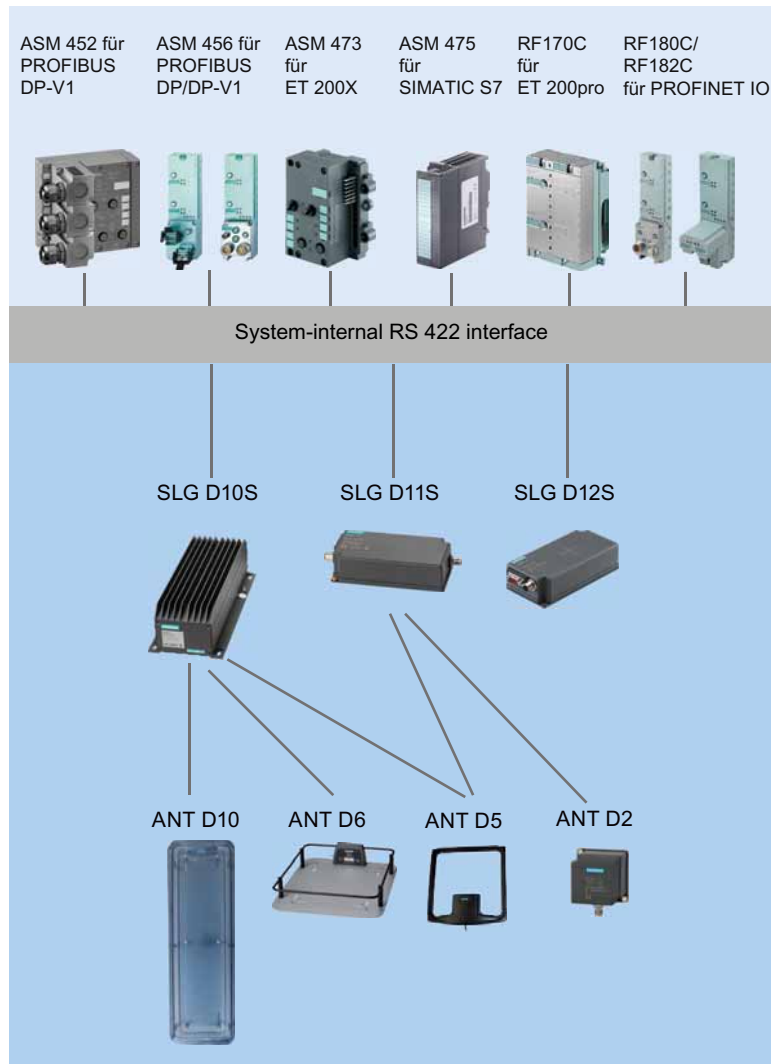

Figure 7-1 Write/read devices with RS422 interface

Application area

The SLG D1xS provides inductive communication with the mobile data storage units (MDS) and serial coupling to the interface modules (ASM). A range of different SLGs are available for small, medium and large distances to the MDS meeting all customer requirements.

- SLG D10S with
 - ANT D5
 - ANT D6
 - ANT D10
- SLG D11S with
 - ANT D2
 - ANT D5
- SLG D12S with integral antenna
- SLG D12S with integral antenna (plug-in version)

The rugged housing and high degree of protection (IP65) permit use even under the toughest industrial conditions.

Design and function

The SLG implements the commands received from the interface module. These commands and the data to be written or read are processed by a corresponding modulator/demodulator circuit.

Communication between the MDS and SLG is performed over an inductive alternating field.

The transmittable quantity of information between SLG and MDS depends on:

- The speed at which the MDS moves through the transmission window of the SLG antenna
- The length of the transmission window
- The MDS type

Table 7- 1 Overview of SLG with RS 422 interface

SLG with ANT		Operating distance S _a (depending on MDS)	Limit distance S _g (depending on MDS)	Temperature range (during operation)	SLG dimensions (L x W x H) in mm	Antenna dimensions (L x W x H) in mm	Degree of protection
SLG D10S	ANT D5	0 to 400 mm	480 mm	-20 to +55 °C	320 x 145 x 100	340 x 325 x 38	IP65
	ANT D6	0 to 550 mm	650 mm	-20 to +55 °C	320 x 145 x 100	580 x 480 x 110	IP65
	ANT D10	0 to 400 mm	480 mm	-20 to +55 °C	320 x 145 x 100	1150 x 365 x 115	IP65
SLG D11S	ANT D2	35 to 70 mm	90 mm	-20 to +70 °C	160 x 80 x 40	75 x 75 x 40	IP65
	ANT D5	0 to 300 mm	380 mm	-20 to +55 °C	160 x 80 x 40	340 x 325 x 38	IP65
SLG D12S ¹⁾		0 to 120 mm	160 mm	-20 to +55 °C	160 x 80 x 40	-	IP65
SLG D12S (plug-in version) ¹⁾		0 to 120 mm	160 mm	-25 to +55 °C	160 x 80 x 40	-	IP67

¹⁾ Integral antenna

Definition of IP65:

- Protection against the ingress of dust (dustproof)
- Complete touch protection
- Protection against water jets

7.2 SLG D10S basic unit

7.2.1 Features

SLG D10S	Features	
	Performance range	The SLG D10S is a basic unit in the high-end range with a serial interface.
	Interface	Serial interface RS 422
	Communication	via interface modules to SIMATIC S7 or PROFIBUS DP-V1/PROFINET/Ethernet IP
	Range	up to 650 mm (depends on antenna)
	Connectable antennas	<ul style="list-style-type: none"> • ANT D5 • ANT D6 • ANT D10 (2 to 4 antennas can be connected via an antenna duplexer)
	Connectable ASM	<ul style="list-style-type: none"> • ASM 452 • ASM 456 • ASM 473 • ASM 475 • RF170C • RF180C • RF182C
	Degree of protection	IP65
	Multitag capability	Yes

7.2.2 Ordering data

Table 7- 2 Ordering data for SLG D10S basic unit

SLG D10S	Order No.
SLG D10S basic device without antenna; with serial interface RS422 for connection to ASM 4xx	6GT2698-2AA00

Table 7- 3 Ordering data for SLG D10S basic unit accessories

SLG D10S accessories		Order No.
24 V connecting cable	Length 5 m	6GT2491-1HH50
Wide-range power supply unit for SIMATIC RF systems (100...240 V AC / 24 V DC / 3 A) with 2 m plug-in cable with country-specific connector. For further information, see Chapter Wide-range power supply unit for SIMATIC RF systems (Page 267)	EU	6GT2898-0AA00
	UK	6GT2898-0AA10
	US	6GT2698-0AA20
ASM - SLG D10S plug-in cables		
ASM 456 RF170C RF180C RF182C	Length 2 m	6GT2691-0FH20
ASM plug-in cables		
ASM 475	Length 2 m	6GT2891-0EH20
	Length 5 m	6GT2891-0EH50
ASM 473 ASM 452	Length 2 m	6GT2891-1CH20
	Length 5 m	6GT2891-1CH50
Extension cables		
ASM 456	Length 2 m	6GT2891-0FH20
	Length 5 m	6GT2891-0FH50
	Length 10 m	6GT2891-0FN10
	Length 20 m	6GT2891-0FN20
	Length 50 m	6GT2891-0FN50

7.2.3 Technical data

Table 7- 4 Technical data for SLG D10S basic unit

Inductive interface to the MDS	
Transmission frequency	13.56 MHz
Transponders supported	Transponders according to ISO 15693 and I-Code1
Serial interface to the user	
Transmission protocol	RS 422
Transmission protocol	Asynchronous 8 bit
Data transmission rate	19.2 Kbaud to 115.2 Kbaud (depending on ASM)
Data backup	CRC 16
Transmit power	up to 10 W
Write/read distances for SLG	650 mm typically (see field data)
Software functions	Read, write, initialize MDS The Repeat command is not permissible. A buffer of up to 256 bytes is available in the SLG for concatenating commands For one command, therefore, it is only possible to combine commands until the sum of the header and user data of the individual message frames does not exceed this value. FC 45 limits the user data length for each individual message frame to 233 bytes.
Programming	FC 45
Transmission protocol	3964R
Multitag	Available soon
Power supply	--- DC 24 V ± 5 %
Current consumption	<ul style="list-style-type: none"> • Operation • Inrush current, momentary
	<ul style="list-style-type: none"> • up to 1.4 A • 2.8 A/50 ms
Cable length for SLG S7	
<ul style="list-style-type: none"> • With RS 422 	<ul style="list-style-type: none"> • 300 m
Digital inputs/outputs	None
Enclosure dimensions (L x W x H) in mm	320 x 145 x 100 (without connector)
Color	Anthracite
Material	Aluminum
Connector	
<ul style="list-style-type: none"> • Antenna (plugs into SLG) • RS 422 interface • Power supply 	<ul style="list-style-type: none"> • TNC connector • 9-pin Sub-D connector (male) • 4-pin M12 connector (male)
SLG fixing	4 x M6 screws

Ambient temperature	
• Operation	• -20 °C to +55 °C
• Transport and storage	• -25 °C to +70 °C
MTBF	7.5 x 10 ⁴ hours
Degree of protection according to EN 60529	IP65 (UL: for indoor use only)
Shock resistant according to EN 60721-3-7 Class 7M2	30 g
Total shock response spectrum Type II	
Vibration according to EN 60721-3-7 Class 7M2	1 g (9 to 200 Hz)/1.5 g (200 to 500 Hz)
Weight, approx.	3500 g
Approvals	<ul style="list-style-type: none"> • CE • FCC • IC • Harmless to heart pacemakers • UL 60950

7.2.4 FCC information

Siemens MOBY D SLG D10S

FCC ID: NXW-MOBYD-SLGD10

This device complies with Part 15 of the FCC Rules. Operation is subject to the following two conditions:

- (1) This device may not cause harmful interference, and
- (2) This device must accept any interference that may cause undesired operation.

Note

The manufacturer is not responsible for any radio or TV interference caused by unauthorized changes and modifications to this equipment:

Such modifications could void the user's authority to operate the equipment.

7.2.5 Dimension drawing

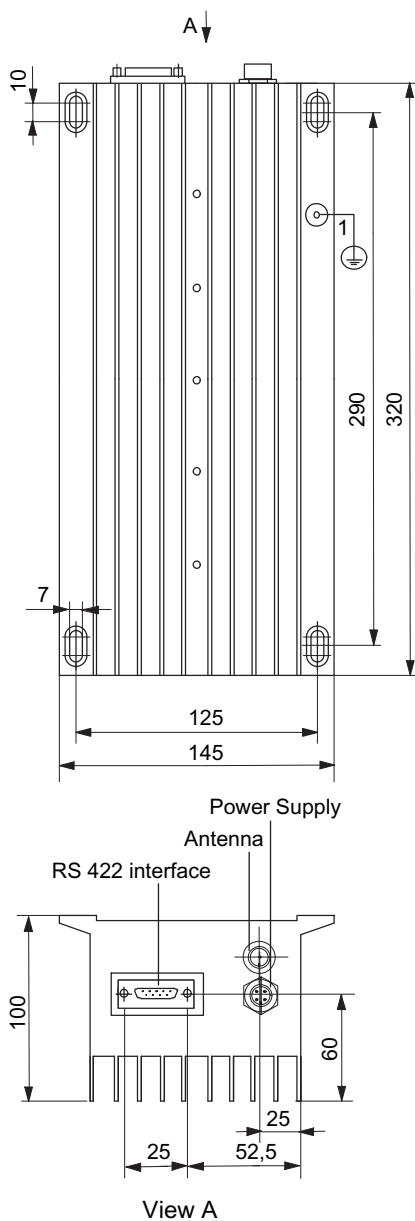

Note:
The SLG must be grounded on grounding screw 1.

Dimensions in mm

Figure 7-2 Dimension drawing of SLG D10S basic unit

7.3 SLG D11S basic unit

7.3.1 Features

SLG D11	Features	
	Performance range	The SLG D11S is a basic unit in the medium performance range with a serial interface.
	Interface	RS422 serial interface
	Communication	via interface modules to SIMATIC S7 or PROFIBUS DP-V1/PROFINET/Ethernet IP
	Connectable ASM	<ul style="list-style-type: none"> • ASM 452 • ASM 456 • ASM 473 • ASM 475 • RF170C • RF180C • RF182C
	Programming options	e.g. via FC 45
	Degree of protection	IP65
	Multitag capability	no

7.3.2 Ordering data

Table 7- 5 Ordering data for SLG D11S basic unit

SLG D11S	Order No.
SLG D11S basic device without antenna; with serial interface RS422 for connection to ASM.	6GT2698-2AC00

Table 7- 6 Ordering data for SLG D11S basic unit accessories

SLG D11S accessories		Order No.
24 V connecting cable	Length 5 m	6GT2491-1HH50
Wide-range power supply unit for SIMATIC RF systems (100...240 V AC / 24 V DC / 3 A) with 2 m plug-in cable and country-specific connector	EU	6GT2898-0AA00
	UK	6GT2898-0AA10
	US	6GT2898-0AA20
ASM - SLG D11S connecting cables		
ASM 456 RF170C RF180C RF182C	Length 2 m	6GT2691-0FH20
ASM plug-in cables		
ASM 475	Length 2 m	6GT2891-0EH20
	Length 5 m	6GT2891-0EH50
ASM 473 ASM 452	Length 2 m	6GT2891-1CH20
	Length 5 m	6GT2891-1CH50
Extension cables		
ASM 456	Length 2 m	6GT2891-0FH20
	Length 5 m	6GT2891-0FH50
	Length 10 m	6GT2891-0FN10
	Length 20 m	6GT2891-0FN20
	Length 50 m	6GT2891-0FN50

7.3.3 Technical specifications

Table 7- 7 Technical data for SLG D11S

Inductive interface to the MDS	
Transmission frequency	13.56 MHz
Transponders supported	Transponders to ISO 15693 and I-Code1
Serial interface to the user	RS 422
Transmission protocol	Asynchronous 8 bit
Data transmission rate	19.2 Kbaud
Data backup	CRC 16
Transmit power	1 W (reset parameter 04 hex)
Write/read distances SLG - MDS	See
Software functions	Read, write and initialize MDS Concatenated commands are not permitted. The Repeat command is not implemented. The largest possible useful data length in a command is 233 bytes.
Programming	FC 45
Transmission protocol	3964R
Multitag	no
Power supply	
• Operation	• --- DC 24 V
• Permitted range	• --- DC 20 V ... 30 V (--- DC 24 V ± 5 % UL only)
Current consumption	
• Operation	• 200 mA
• Inrush current, momentary	• 600 mA
Cable length SLG – SIMATIC S7	
• With RS 422	• 300 m
Digital inputs/outputs	None
Dimensions (L x W x H) in mm	160 x 80 x 40 without connector
Color	Anthracite
Material	Plastic PA 12
Connectors	
• Antenna (plugs into SLG)	• TNC connector
• RS-422 interface	• 9-pin Sub-D connector (male)
• Power Supply	• 4-pin M12 connector (male)
SLG fixing	2 x M5 screws
Tightening torque (at room temperature)	≤ 2 Nm
Ambient temperature	
• Operation	• -25 °C to +55 °C
• Transport and storage	• -25 °C to +70 °C

7.3 SLG D11S basic unit

MTBF	2.0 x 10 ⁵ hours
Degree of protection to EN 60529	IP65 (UL: For indoor use only)
Shock resistant to EN 60721-3-7, Class 7M2 Total shock response spectrum, Type II	30 g
Vibration resistance in accordance with EN 60721-3-7, Class 7M2	1 g (9 to 200 Hz)/ 1.5 g (200 to 500 Hz)
Weight, approx.	600 g
Approvals	<ul style="list-style-type: none">• CE• FCC• IC• Harmless to heart pacemakers• UL 60950

7.3.4 FCC information

Siemens MOBY D SLG D11S

FCC ID: NXW-MOBYD-SLGD11

This device complies with Part 15 of the FCC Rules. Operation is subject to the following two conditions:

- (1) This device may not cause harmful interference, and
- (2) This device must accept any interference that may cause undesired operation.

Note

The manufacturer is not responsible for any radio or TV interference caused by unauthorized changes and modifications to this equipment:

Such modifications could void the user's authority to operate the equipment.

7.3.5 Dimension drawing

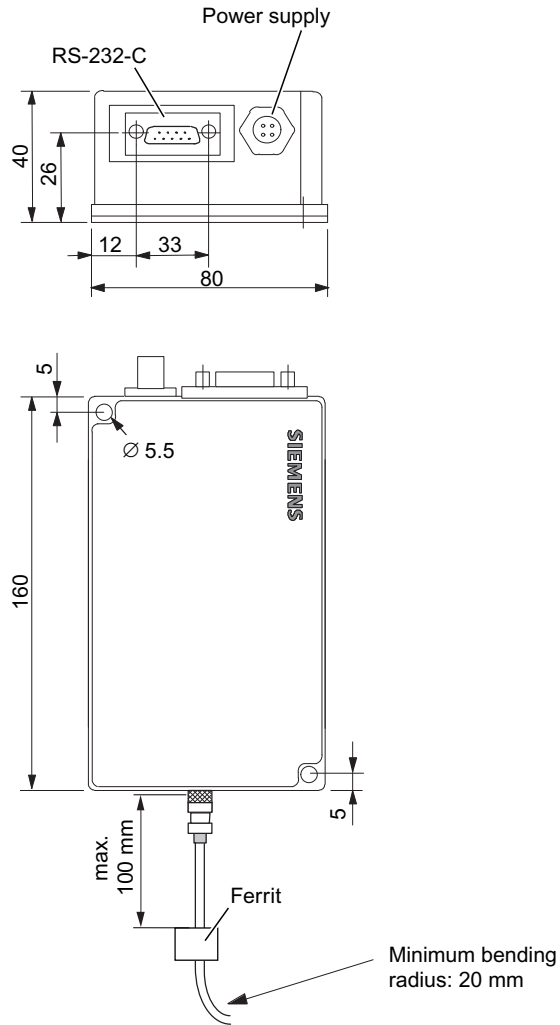

Dimensions in mm

Figure 7-3 Dimension drawing of SLG D11S

7.4 SLG D12S

7.4.1 Features

SLG D12S	Features	
	Performance range	The SLG D12S is a write/read device in the lower performance range with serial interface.
	Range	up to 160 mm
	Interface	RS232 serial interface
	Communication	via interface modules to SIMATIC S7 or PROFIBUS DP-V1/PROFINET/Ethernet IP
	Connectable ASM	<ul style="list-style-type: none"> • ASM 452 • ASM 456 • ASM 473 • ASM 475 • RF170C • RF180C • RF182C
	Antenna	integrated
	Programming options	e.g. via FC 45
	Degree of protection	IP65
	Multitag capability	no

7.4.2 Ordering data

Table 7- 8 Ordering data for SLG D12S

SLG D12S	Order No.
SLG D12S with integrated antenna; with serial interface RS422 for connection to ASM	6GT2602-0AB00

Table 7- 9 Ordering data for SLG D12S accessories

SLG D12S accessories		Order No.
24 V connecting cable	Length 5 m	6GT2491-1HH50
Wide-range power supply unit for SIMATIC RF systems (100...240 V AC / 24 V DC / 3 A) with 2 m plug-in cable with country-specific connector. For further information, see Chapter Wide-range power supply unit for SIMATIC RF systems (Page 267)	EU	6GT2898-0AA00
	UK	6GT2898-0AA10
	US	6GT2698-0AA20
ASM - SLG D12S plug-in cables		
ASM 456 RF170C RF180C RF182C	Length 2 m	6GT2691-0FH20
ASM plug-in cables		
ASM 475	Length 2 m	6GT2891-0EH20
	Length 5 m	6GT2891-0EH50
ASM 473 ASM 452	Length 2 m	6GT2891-1CH20
	Length 5 m	6GT2891-1CH50
Extension cables		
ASM 456	Length 2 m	6GT2891-0FH20
	Length 5 m	6GT2891-0FH50
	Length 10 m	6GT2891-0FN10
	Length 20 m	6GT2891-0FN20
	Length 50 m	6GT2891-0FN50

7.4.3 Technical data

Table 7- 10 Technical data for SLG D12S

Inductive interface to the MDS	
Transmission frequency	13.56 MHz
Transponders supported	Transponders according to ISO 15693 and I-Code1
Serial interface to the user	RS 422
Transmission protocol	Asynchronous 8 bit
Data transmission rate	19.2 Kbaud
Data backup	CRC 16
Transmit power	1 W (reset parameter 04 hex)
Write/read distances SLG - MDS	160 mm typically (see field data)
Software functions	Read, write and initialize MDS Concatenated commands are not permitted. The Repeat command is not implemented. The largest possible useful data length in a command is 233 bytes.
Programming	FC 45
Transmission protocol	3964R
Multitag	no
Power supply	
• Operation	• --- DC 24 V
• Permissible range	• --- DC 20 V ... 30 V (--- DC 24 V ± 5 % UL only)
Current consumption	
• Operation	• 150 mA
• Inrush current, momentary	• 600 mA
Cable length SLG – SIMATIC S7	
• With RS 422	• 300 m
Digital inputs/outputs	None
Enclosure dimensions (L x W x H) in mm	160 x 80 x 40 (without connector)
• Color	Anthracite
• Material	Plastic PA 12
Connector	
• RS 422 interface	• 9-pin Sub-D connector (male)
• Power supply	• 4-pin M12 connector (male)
Mounting	2 x M5 screws
Ambient temperature	
• Operation	• -25 °C to +55 °C
• Transport and storage	• -25 °C to +70 °C
MTBF	2.0 x 10 ⁵ hours
Degree of protection according to EN 60529	IP65 (UL: for indoor use only)

Shock resistant according to EN 60721-3-7 Class 7M2 Total shock response spectrum Type II	30 g
Vibration according to EN 60721-3-7 Class 7M2	1 g (9 to 200 Hz)/ 1.5 g (200 to 500 Hz)
Weight, approx.	600 g
Approvals	<ul style="list-style-type: none"> • CE • FCC • IC • Harmless to heart pacemakers • UL 60950

7.4.4 FCC information

Siemens MOBY D SLG D12S

FCC ID: NXW-MOBYD-SLGD12

This device complies with Part 15 of the FCC Rules. Operation is subject to the following two conditions:

- (1) This device may not cause harmful interference, and
- (2) This device must accept any interference that may cause undesired operation.

Note

The manufacturer is not responsible for any radio or TV interference caused by unauthorized changes and modifications to this equipment:

Such modifications could void the user's authority to operate the equipment.

7.4.5 Transmission window

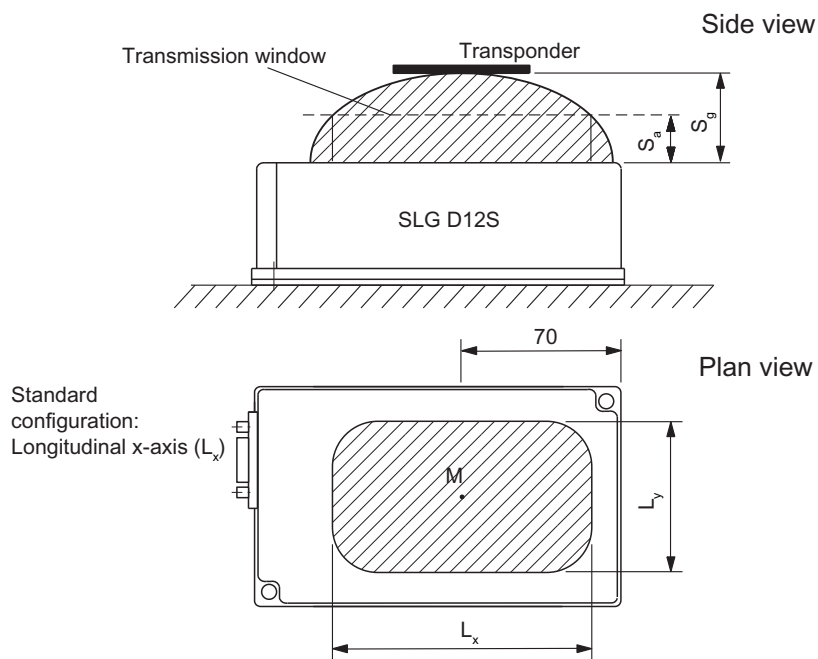

Lx 120 mm
Ly 60 mm

Figure 7-4 Transmission window for SLG D12S

7.4.6 Secondary fields

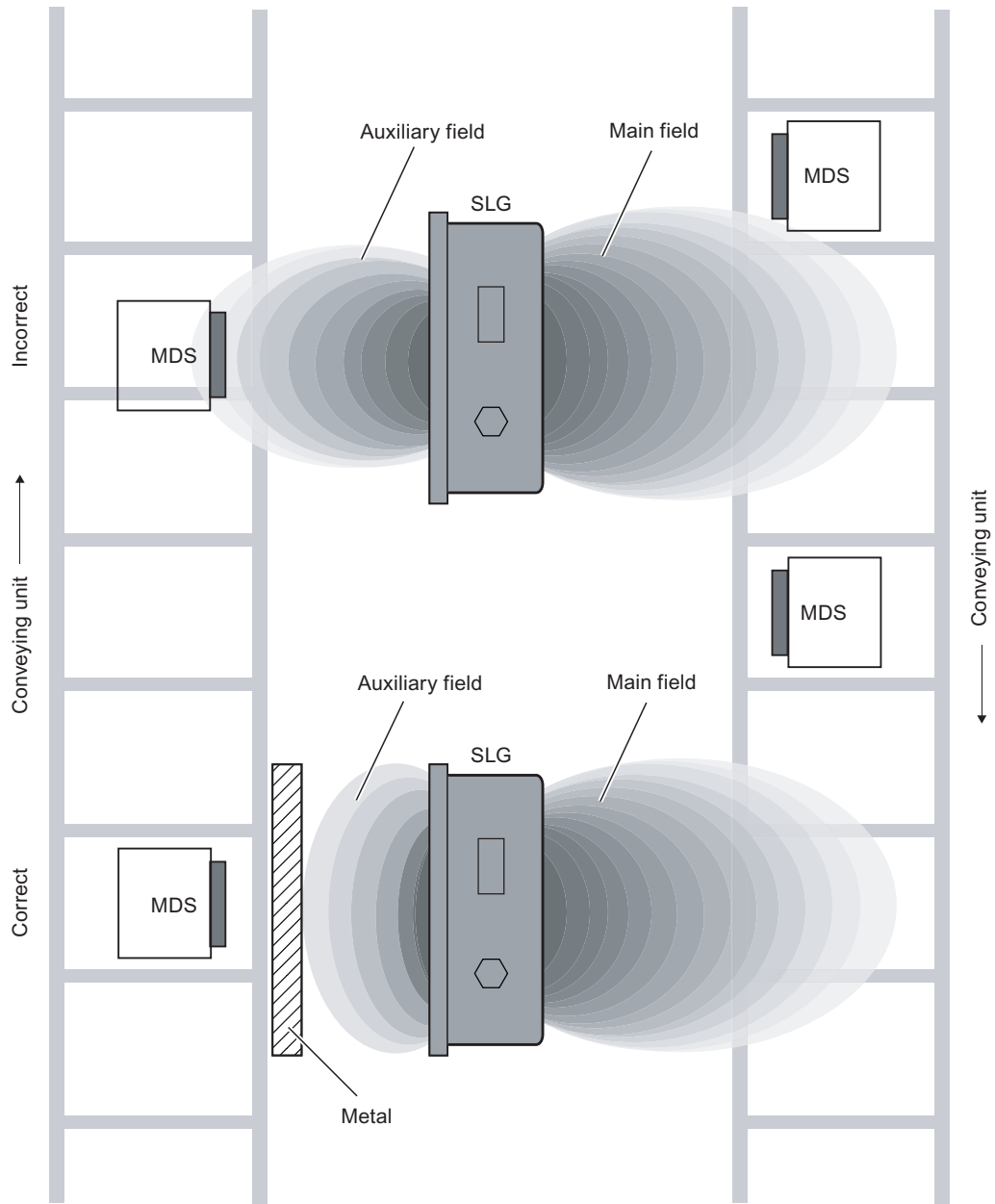

Figure 7-5 MDS shielding

To avoid undesired reading of the MDS outside the main field, the MDS must be shielded.

7.4.7 Influence of metal

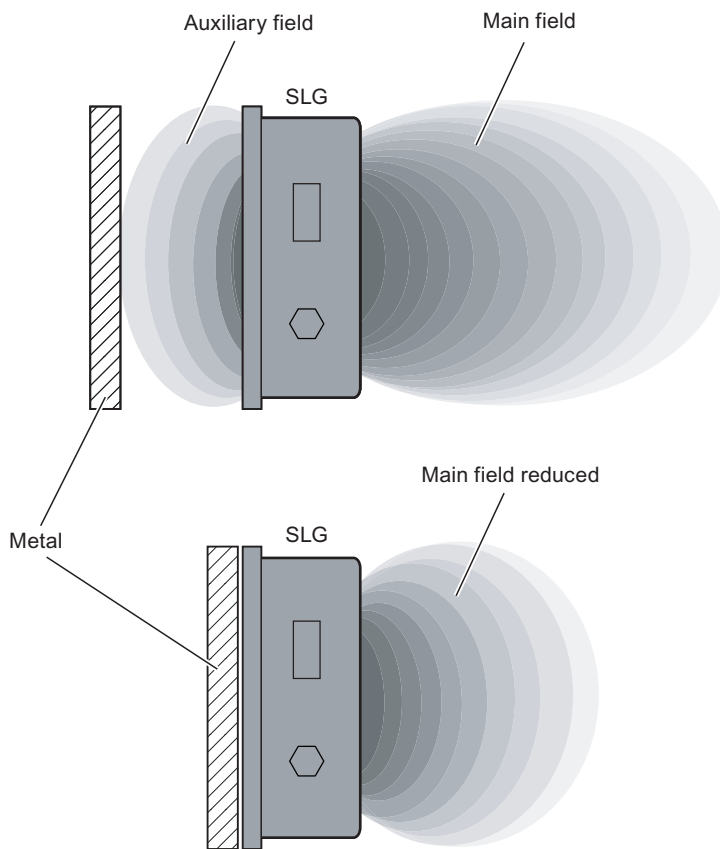

Figure 7-6 Reduction in range through influence of metal

7.4.8 Metal-free area

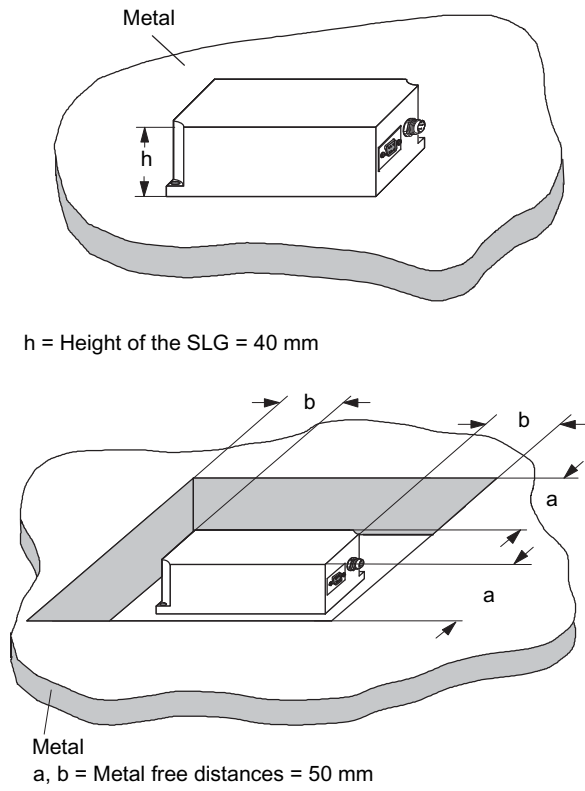
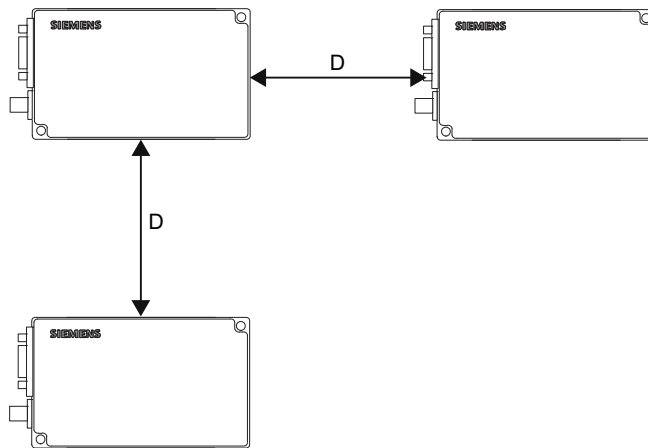

Figure 7-7 Metal-free area for SLG D12S

7.4.9 Minimum distances between several SLGs

Definition of distance D



$D \geq 0.5 \text{ m}$

Figure 7-8 Distance D: SLG D12S

7.4.10 Dimension drawing

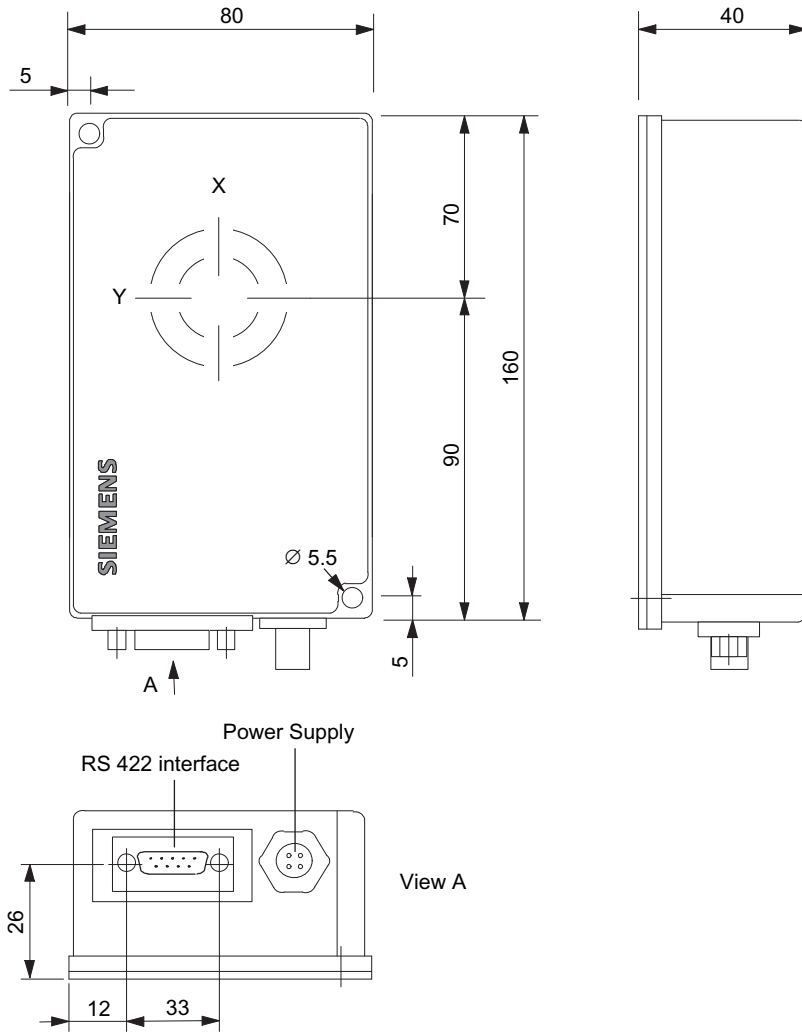

Dimensions in mm

Figure 7-9 Dimension drawing of SLG D12S

7.5 SLG D12S (plug-in version)

7.5.1 Features

SLG D12S (plug-in version)	Features	
 <p>The image shows a Siemens SLG D12S (plug-in version) device. It is a dark grey, rectangular module with a small circular antenna on top. The front panel features a Siemens logo, the model name 'SLG D12S', and technical specifications including 'IP67', 'RS422', and 'M12'. A connector is visible on the left side.</p>	Performance range	The SLG D12S (plug-in version) is a write/read device in the lower performance range with serial interface.
	Range	up to 160 mm
	Interface	RS422 serial interface
	8-pin M12 connector	for <ul style="list-style-type: none"> • Power supply • Data communication
	Communication	via interface modules to SIMATIC S7 or PROFIBUS DP-V1/PROFINET/Ethernet IP
	Connectable ASM	<ul style="list-style-type: none"> • ASM 452 • ASM 456 • ASM 473 • ASM 475 • RF170C • RF180C • RF182C
	Antenna	integrated
	Programming options	e.g. via FB 45/FC 45
	High degree of protection	IP67
	Multitag capability	no

7.5.2 Ordering data

Table 7- 11 SLG D12S special version ordering data

SLG D12S special version	Order No.
Write/read device SLG D12S With a serial RS 422 interface for connection to ASM 452, ASM 456, ASM 473, ASM 475, RF170C, RF180C and RF181C, with an integral antenna	6GT2602-0AB10-0AX0

Table 7- 12 SLG D12S special version accessories ordering data

SLG D12S special version accessories: Preassembled connection cables Reader - ASM		Order No.
ASM 475	Length: 2 m	6GT2891-0EH20
	Length: 5 m	6GT2891-0EH50
ASM 452 ASM 473	Length: 2 m	6GT2891-1CH20
	Length: 5 m	6GT2891-1CH50
ASM 456 RF170C RF180C	Length: 2 m	6GT2891-0FH20
	Length: 5 m	6GT2891-0FH50
	Length: 10 m	6GT2891-0FN10
	Length: 20 m	6GT2891-0FN20
	Length: 50 m	6GT2891-0FN50

Note

The connecting cables for ASM 475, ASM 452/473 can be extended accordingly with the connecting cables 6GT2891-0Fxxx.

7.5.3 Technical specifications

Table 7- 13 Technical specifications for SLG D12S special version

Inductive interface to the MDS	
Transmission frequency	13.56 MHz
Transponders supported	Transponders to ISO 15693 and I-Code1
Serial interface to the user	RS 422
Transmission protocol	Asynchronous 8 bit
Data transmission rate	19.2 Kbaud
Data backup	CRC 16
Transmit power	1 W (reset parameter 04 hex)
Write/read distances SLG - MDS	160 mm typically (see field data)
Software functions	Read, write and initialize MDS Concatenated commands are not permitted. The Repeat command is not implemented. The largest possible useful data length in a command is 233 bytes.
Programming	FB/FC 45
Transmission protocol	3964R
Multitag	no
Power supply	Via ASM
Current consumption	
<ul style="list-style-type: none"> • Operation • Inrush current, momentary 	<ul style="list-style-type: none"> • 150 mA • 600 mA
Cable length SLG – SIMATIC S7	
<ul style="list-style-type: none"> • With RS 422 	<ul style="list-style-type: none"> • 300 m
Digital inputs/outputs	None
Dimensions (L x W x H) in mm	160 x 80 x 40 (without connector)
<ul style="list-style-type: none"> • Color • Material 	<ul style="list-style-type: none"> Anthracite Plastic PA 12
Connector	
<ul style="list-style-type: none"> • RS-422 interface/power supply 	<ul style="list-style-type: none"> • 8-pin M12 connector (male)
Mounting	2 x M5 screws
Ambient temperature	
<ul style="list-style-type: none"> • Operation • Transport and storage 	<ul style="list-style-type: none"> • -25 °C to +55 °C • -25 °C to +70 °C
MTBF	2.0 x 10 ⁵ hours
Degree of protection to EN 60529	IP67
Shock resistant to EN 60721-3-7, Class 7M2 Total shock response spectrum, Type II	30 g
Vibration compliant with EN 60721-3-7, Class 7M2	1 g (9 to 200 Hz)/ 1.5 g (200 to 500 Hz)

Weight, approx.	600 g
Approvals	<ul style="list-style-type: none">• CE• Harmless to heart pacemakers

7.5.4 Field data

Table 7- 14 Field data for SLG D12S special version

Limit distance (S_g)	max. 160 mm (dependent on transponder)
Operating distance (S_a)	0 to 120 mm (dependent on transponder)
Length of transmission window (L_x/L_y)	120 mm/60 mm
Width of the transmission window (W_x/W_y)	48 mm/24 mm
Minimum distance from SLG D12S to SLG D12S	≥ 0.5 m

See also MOBY D System Manual, Chapter .

7.5.5 Transmission window

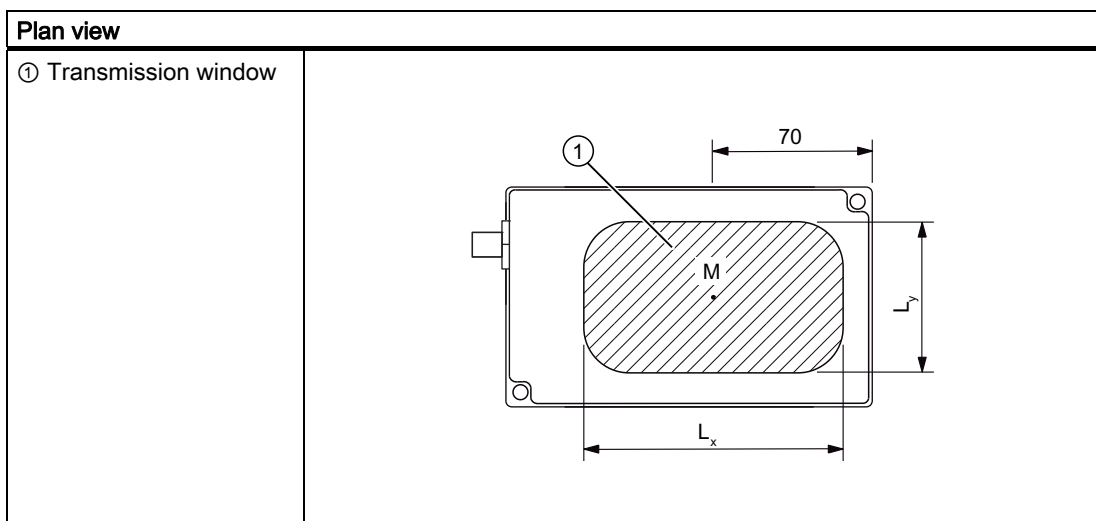
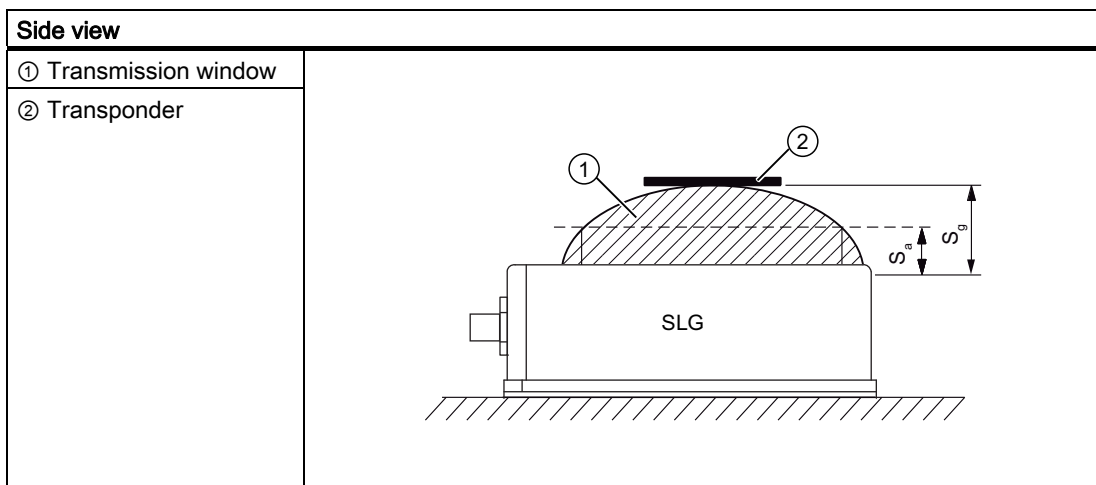

Standard configuration longitudinal, X-axis (L_x)

7.5.6 Secondary fields

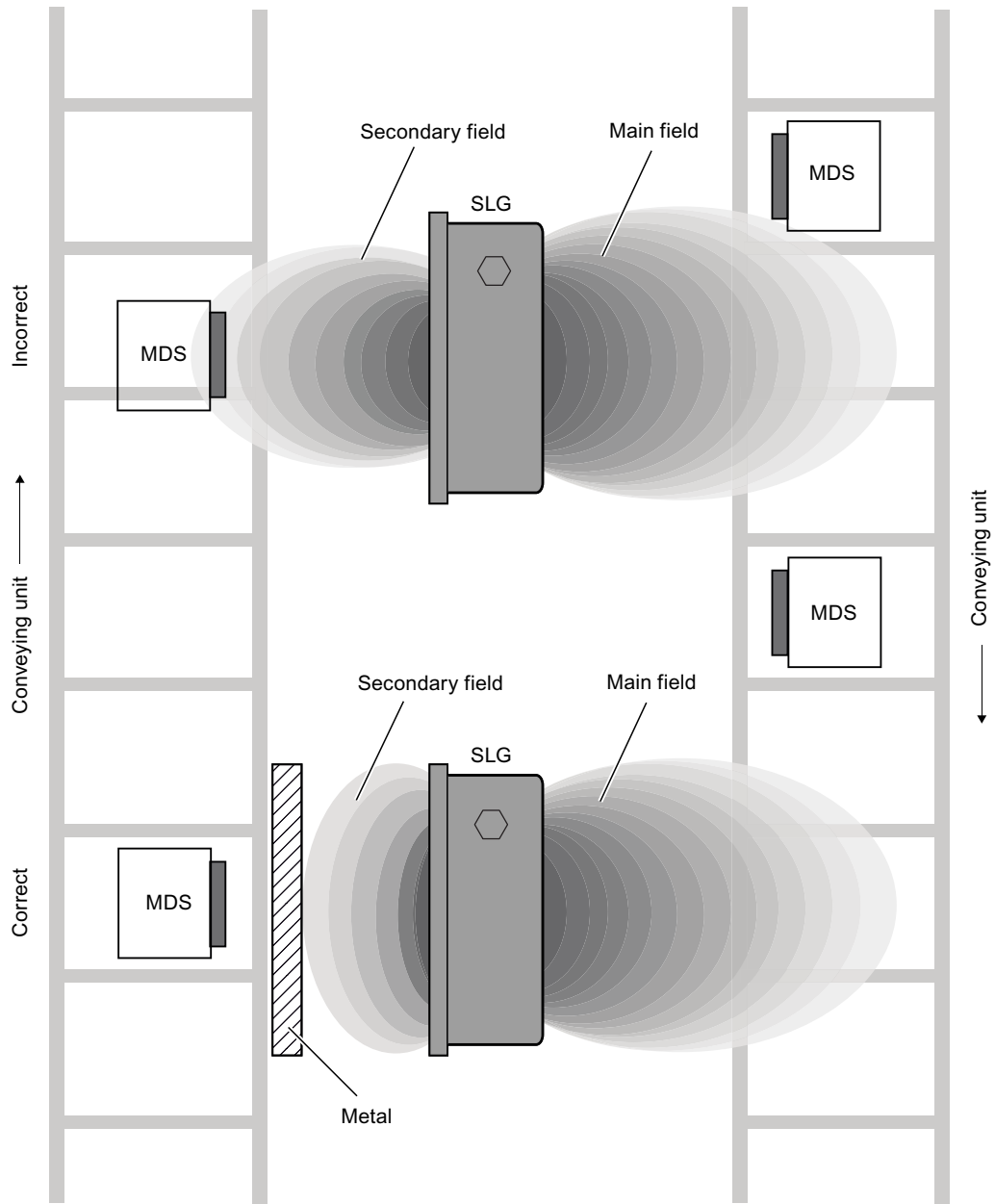

Figure 7-10 MDS shielding

To avoid undesired reading of the MDS outside the main field, the MDS must be shielded.

7.5.7 Influence of metal

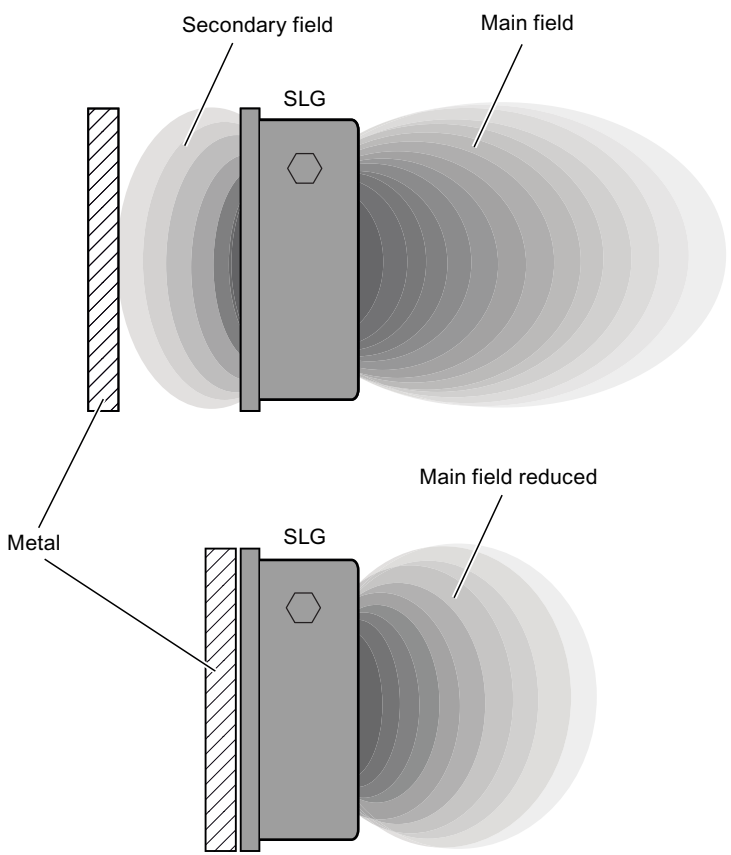
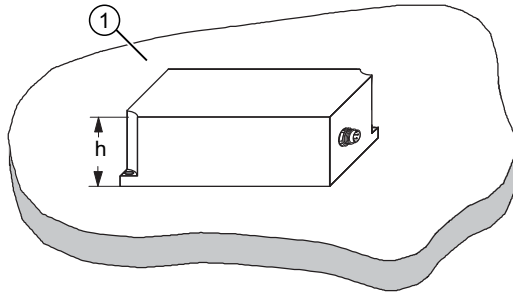

Figure 7-11 Reduction in range through influence of metal

7.5.8 Metal-free area

Mounting the SLG D12S special version on metal



① = Metal

h h = Mechanical height of the SLG = 40 mm

Flush-mounting of SLG D12S special version in metal:

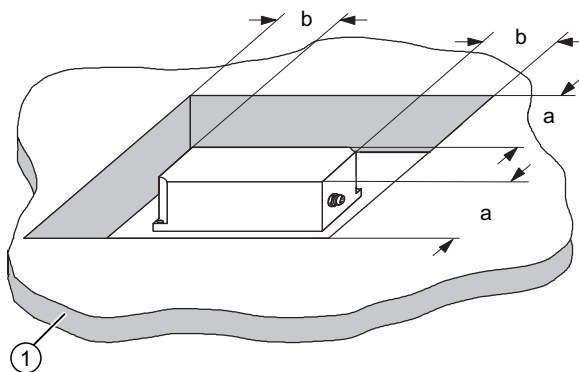

① = Metal

a, b = Metal-free distances = 50 mm

When installing in the vicinity of metal, observe the instructions in the System Manual's Chapter .

7.5.9 Minimum distances between several SLGs

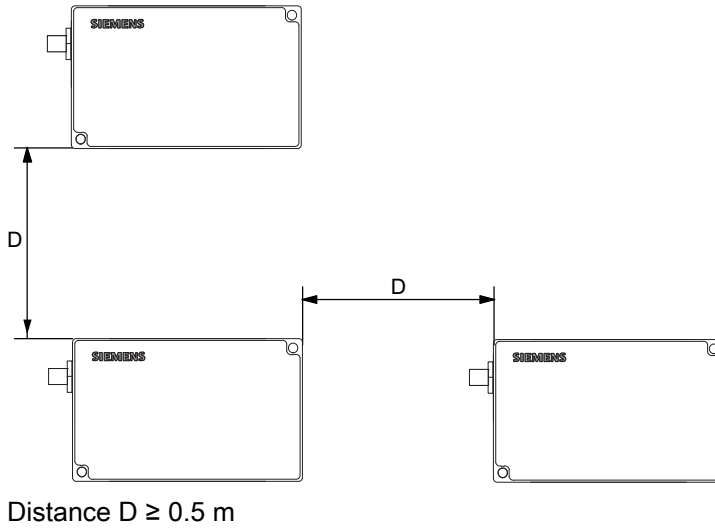

7.5.10 Dimensional diagram

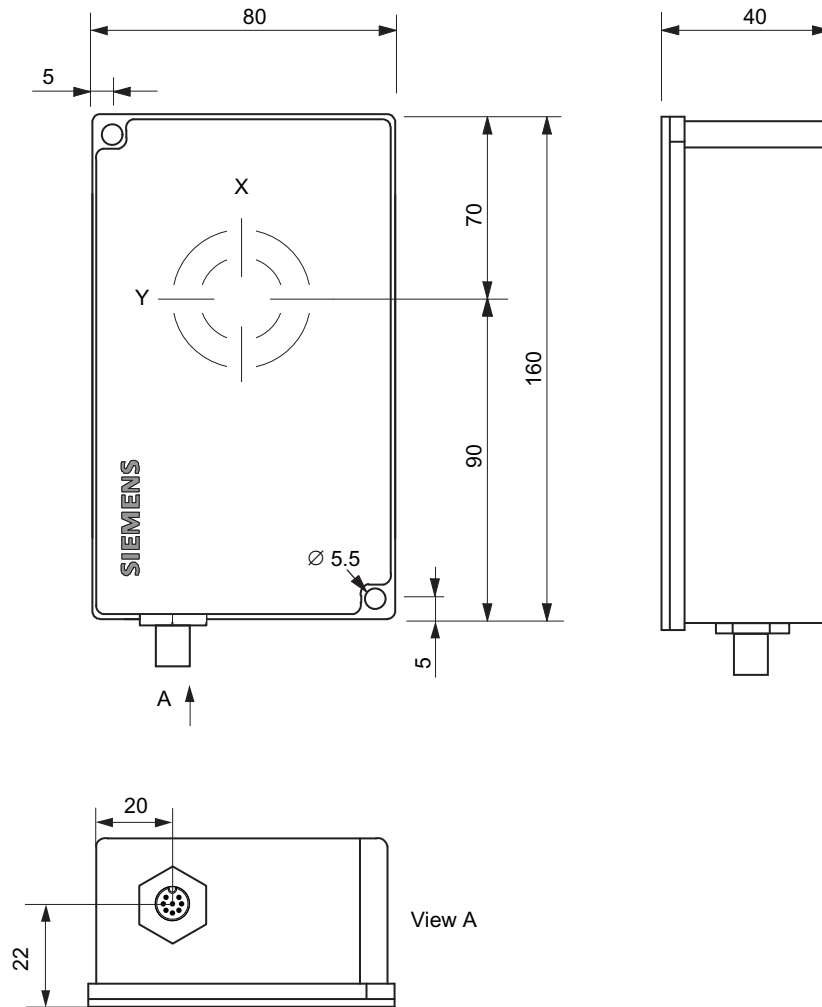

Dimensions in
mm

Figure 7-12 Dimension drawing of SLG D12S special version

Antennas

8.1 ANT D2

8.1.1 Features

ANT D2	Features	
 <p>MOBY D ANT D2 6GT2698-5BB00 SN 123456789.xxx AS A CE</p>	Applications	Suitable for high speeds, e.g. in <ul style="list-style-type: none"> • Overhead conveyors • Assembly lines • Production • Order picking
	Antenna field	Designed for transponders that are directed sideways past the antenna. See Chapter Transmission window (Page 207)
	Writing/reading distance	typ. 60 mm;
	Connecting cable	3.3 m (included in scope of supply)
	Connectable SLGs	<ul style="list-style-type: none"> • SLG D11 • SLG D11S
	Degree of protection	IP65

8.1.2 Ordering data

Table 8- 1 ANT D2 ordering data

Product	Order No.
ANT D2 incl. antenna cable (3.3 m)	6GT2698-5BB00

Table 8- 2 Ordering data for ANTD2 accessories

Accessories	Order No.
Antenna duplexer (with 1 antenna connecting cable 3.3 m)	6GT2690-0AC00
Antenna cable, length 10.5 m	6GT2691-0CN10
Antenna extension, length 7.2 m	6GT2691-0DH72

8.1.3 Technical specifications for ANT D2

Table 8- 3 Technical specifications for ANT D2

Max. write/read distance ANT to MDS (S _g)	See also Field data for MDS and SLG.
Dimensions in mm (L x W x H)	75 x 75 x 40
Antenna cable length in	3.3 m
Color	Anthracite
Material	PA 12 (polyamide 12)
Plug connection	Single-pole TNC connector
Max. power	4 W
Shock resistant according to EN 60721-3-7 Class 7M2 Total shock response spectrum Type II	50 g
Vibration according to EN 60721-3-7 Class 7M2	10 g (5...500 Hz)
Attachment of the antenna	2 x M5 screws
Tightening torque (at room temperature)	≤ 2 Nm
Ambient temperature	<ul style="list-style-type: none"> • Operation • Transport and storage
	<ul style="list-style-type: none"> • -20 °C to +70 °C • -25 °C to +85 °C
MTBF	2 x 10 ⁷ hours
Degree of protection according to EN 60529	IP65
Weight, approx.	260 g
Approvals	<ul style="list-style-type: none"> • CE • FCC • IC • Harmless to heart pacemakers in combination with SLG D11/D11S

8.1.4 Transmission window

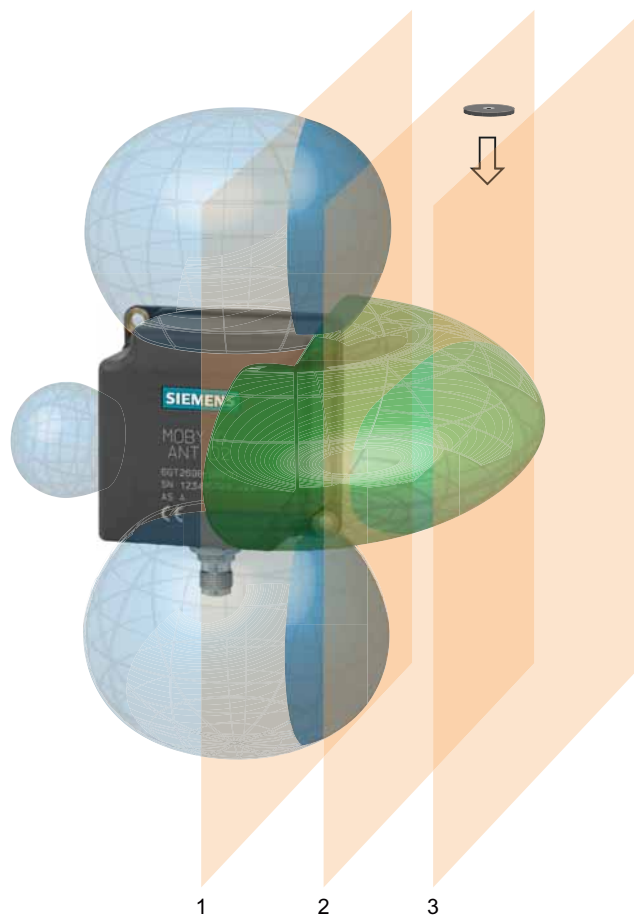

Figure 8-1 Transmission window for ANT D2

1	Level 1
2	Level 2
3	Level 3
↓	Direction of motion of the transponder
Green	Main field (processing field)
Blue	Secondary fields

Operating range (S_a)

The operating range lies between level 1 and level 3.

The operating range between level 1 and 2 includes secondary fields.

The recommended operating range therefore lies in the green main field between Level 2 and Level 3.

Limit distance (S_g)

The limit distance lies on Level 3

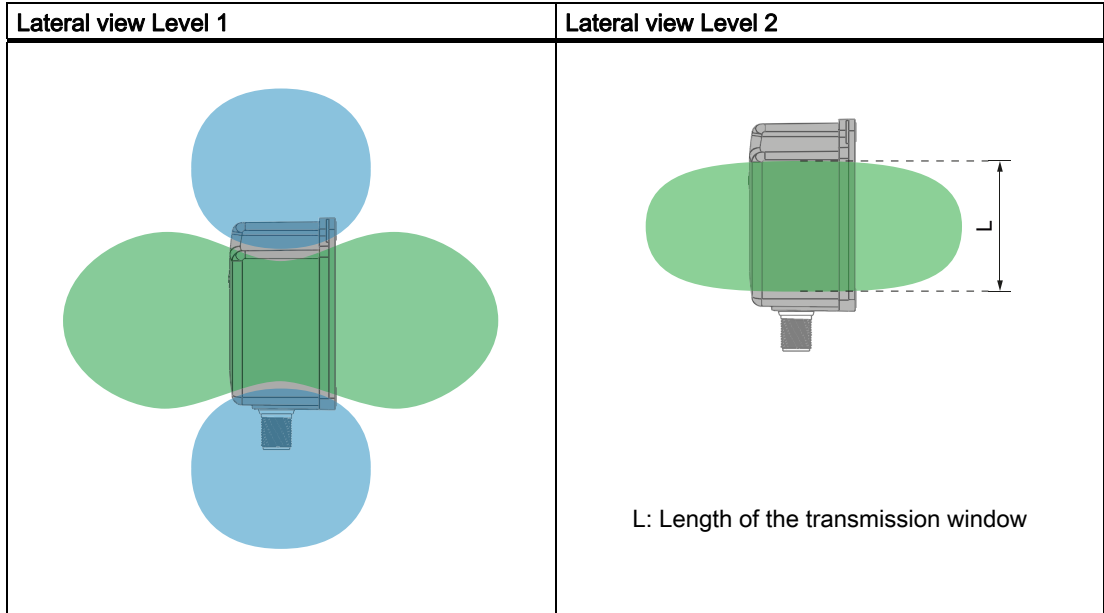

8.1.5 Metal-free area

Direct mounting of the ANT D2 on metal is permitted. No range losses must be expected here.

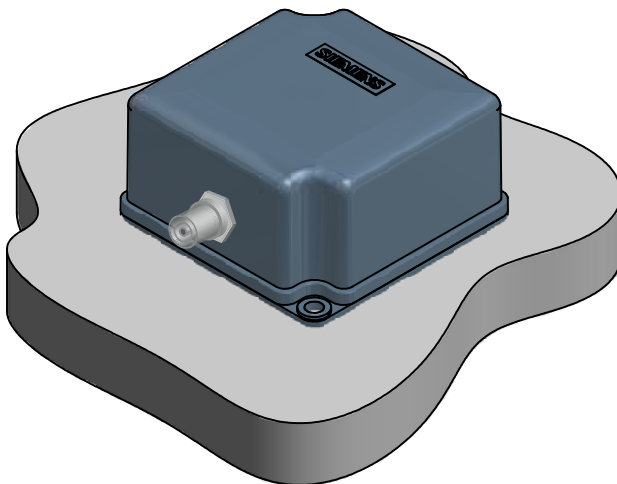

Figure 8-2 Metal-free area for ANT D2

8.1.6 Minimum distance between several ANT D2 antennas

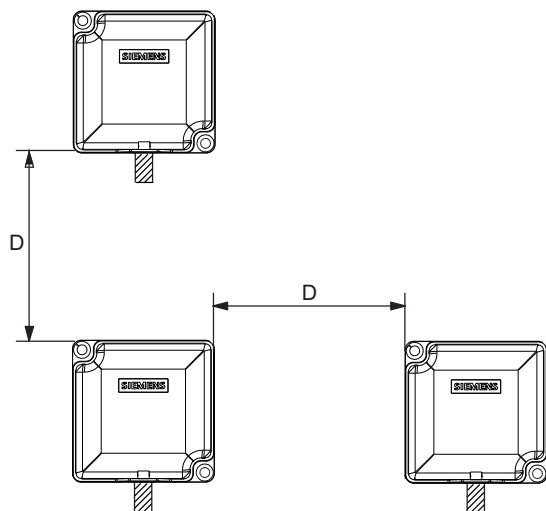

Figure 8-3 Minimum distance between several ANT D2 antennas

Minimum distance D from ANT D2 to ANT D2	$D \geq 500 \text{ mm}$
--	-------------------------

8.1.7 Dimension drawing

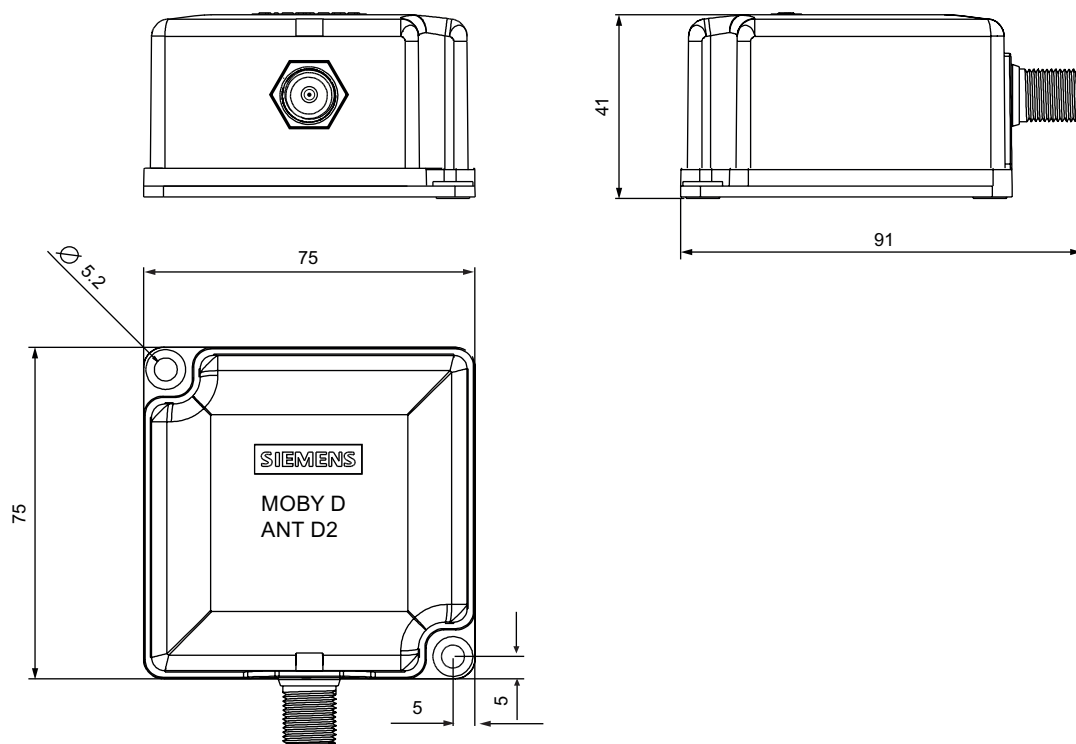



Figure 8-4 Dimension drawing for ANT D2

8.2 ANT D5

8.2.1 Features

ANT D5	Features	
	Applications	Storage, logistics and distribution
	Writing/reading distance	Up to 480 mm (depending on MDS)
	Connecting cable	3.3 m; pre-assembled
	Connectable SLG	<ul style="list-style-type: none"> • SLG D10/10S • SLG D11/11S
	Degree of protection	IP65

8.2.2 Ordering data

Table 8- 4 Ordering data of ANT D5

ANT D5	Order No.
<ul style="list-style-type: none"> • Dimensions L x W x H in mm: 340 x 325 x 38 • Antenna cable 3.3 m; permanently preassembled 	6GT2698-5AA00

Table 8- 5 Ordering data of ANT D5 accessories

Accessories	Order No.
Spacer kit for ANT D5 made of aluminum with plastic spacers incl. fixing screws Individual parts: <ul style="list-style-type: none"> • 1 aluminum plate 380 x 380 x 2 • 4 plastic bolts 100 x 20 • 4 countersunk-head screws M5 x 12 • 4 combination screws M5 x 20 	6GT2690-0AB00
Antenna duplexer (with 1 antenna connecting cable 3.3 m)	6GT2690-0AC00
Antenna cable, length 10.5 m	6GT2691-0CN10
Antenna extension, length 7.2 m	6GT2691-0DH72

8.2.3 Technical data

Table 8- 6 Technical specifications for ANT D5

Max. write/read distance ANT to MDS (S ₉)	480 mm ¹⁾
Dimensions in mm (L x W x H)	340 x 325 x 38
Color	Black
Material	Plastic ASA
Plug connection	1-pin TNC connector
Max. power	10 W (FCC/IC:4 W)
Antenna cable length	3.6 m
Shock resistant according to EN 60721-3-7 Class 7M2 Total shock response spectrum Type II	30 g
Vibration according to EN 60721-3-7 Class 7M2	1 g (9 to 200 Hz)/1.5 g (200 to 500 Hz)
Attachment of the antenna	4 x M5 screws
Ambient temperature	
• Operation	• -20 °C to +55 °C
• Transport and storage	• -25 °C to +70 °C
MTBF	3 x 10 ⁵ hours
Degree of protection according to EN 60529	IP65 (UL: for indoor use only)
Weight, approx.	1 kg
Approvals	<ul style="list-style-type: none"> • CE • FCC • IC • Harmless to heart pacemakers • UL 60950

¹⁾ In order to ensure optimum field data even in the vicinity of metal, ANT D5 is calibrated at the factory at a distance of 100 mm from metal (see the accessory "Spacer kit" in the ordering data section).

8.2.4 Transmission window

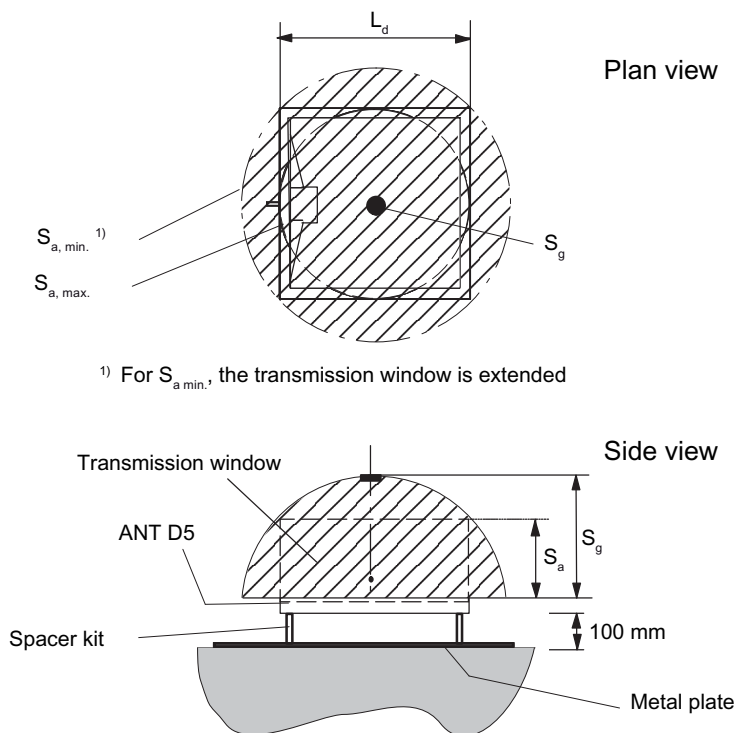

¹⁾ For $S_{a, min.}$, the transmission window is extended

$L_d = 300 \text{ mm}$

Figure 8-5 Transmission window for ANT D5

8.2.5 Metal-free area

Flush-mounted in metal

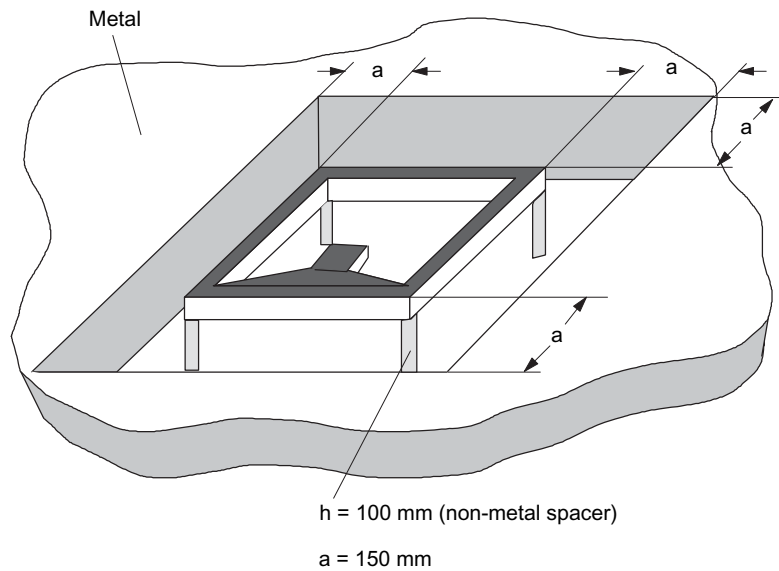

Figure 8-6 Metal-free area for ANT D5

For further information on spacers, see section Ordering data (Page 210) ANT D5 accessories, spacer kit, as well as Dimension drawings (Page 215).

When installing in the vicinity of metal, observe the instructions in the Section

See also

Planning the MOBY D system (Page 25)

8.2.6 Minimum distance between antennas

Definition of distance D

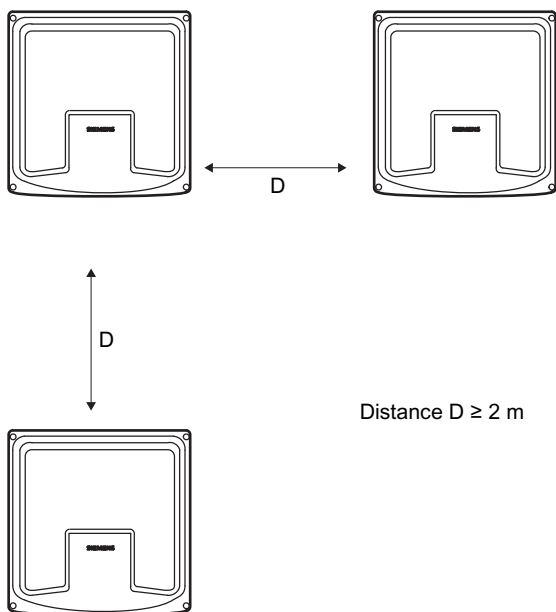

Figure 8-7 Distance D: ANT D5

8.2.7 Dimension drawings

Dimension drawing for ANT D5

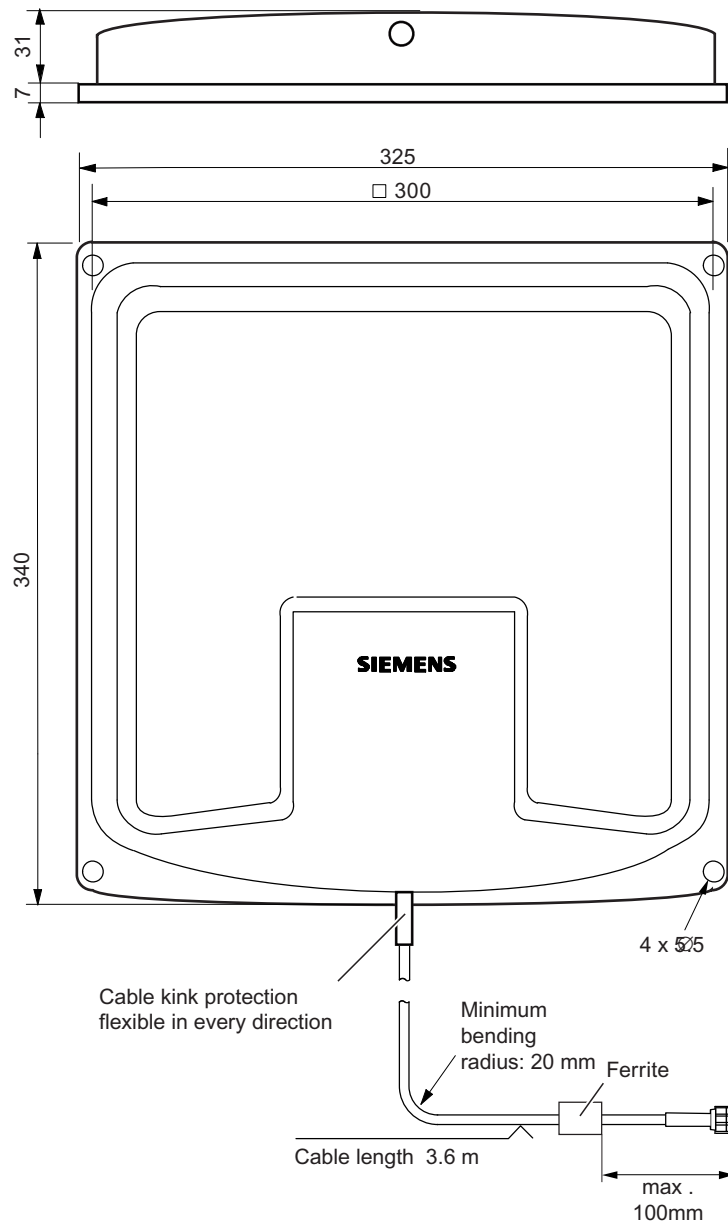
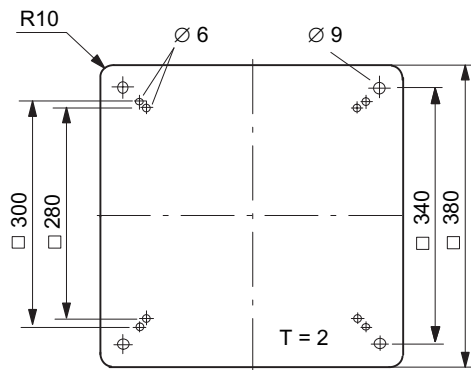

Figure 8-8 Dimension drawing for ANT D5

Dimension drawing and sketch for mounting spacer kit

Aluminium plate:



Plastic bolts:

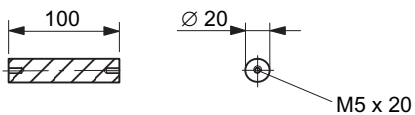

Figure 8-9 Dimension drawing for ANT D5 spacer kit

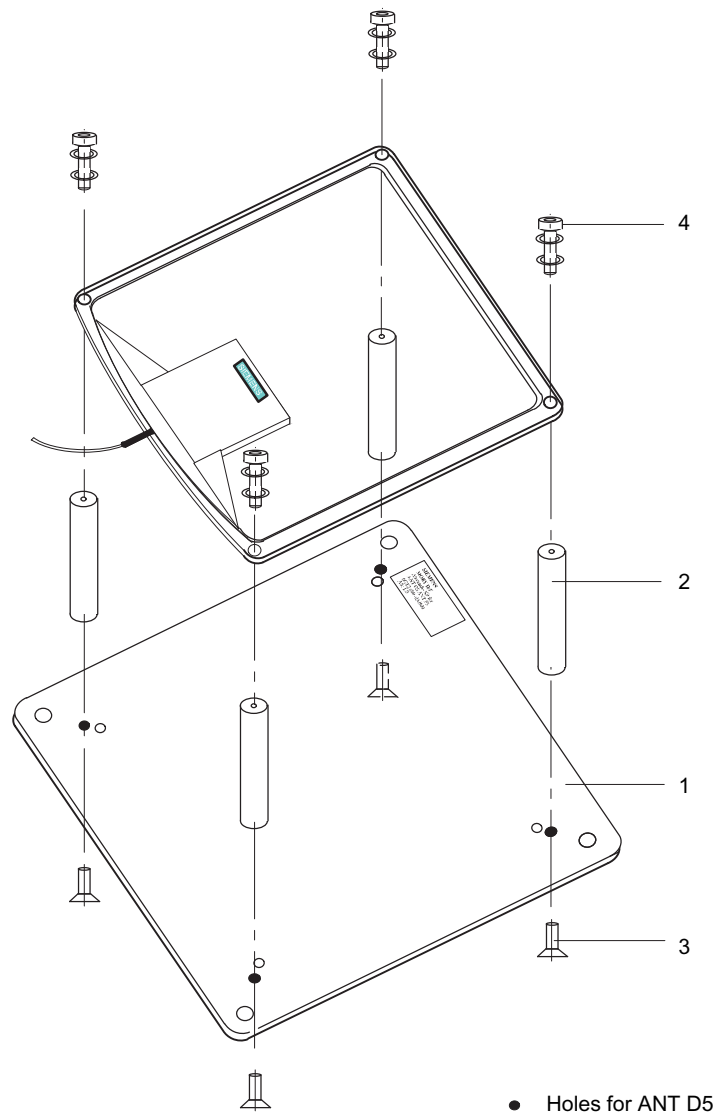



Figure 8-10 Sketch for mounting spacer kit

8.3 ANT D6

8.3.1 Features

ANT D6	Features	
 <p>ANT D6 Covering hood</p>	Applications	<ul style="list-style-type: none"> Storage, logistics and distribution Suitable for high-speed applications with large writing/reading distance
	Writing/reading distance	Up to 650 mm (depending on MDS)
	Connecting cable	3.3 m; included in scope of supply
	Covering hood	Available as accessory
	Connectable SLG	SLG D10/10S
	Degree of protection	IP65 (can also be achieved without covering hood)

8.3.2 Ordering data

Table 8- 7 ANT D6 ordering data

ANT D6	Order No.
<ul style="list-style-type: none"> Dimensions L x W x H in mm: 580 x 480 x 110 (without cover) Antenna cable included in scope of supply 	6GT2698-5AB00

Table 8- 8 Ordering data for ANT D6 accessories

Accessories	Order No.	
Covering hood for ANT D6	6GT2690-0AD00	
Antenna duplexer (with 1 antenna connecting cable 3.3 m)	6GT2690-0AC00	
Antenna cable	Length 3.3 m	6GT2691-0CH33
	Length 10.5 m	6GT2691-0CN10
Antenna extension, length 7.2 m	6GT2691-0DH72	

8.3.3 Technical data

Table 8- 9 Technical specifications for ANT D6

Max. write/read distance ANT to MDS (S ₉)	650 mm
Dimensions in mm (L x W x H)	580 x 480 x 110 (without cover)
Color	Gray/black
Material	Aluminum/plastic
Plug connection	1-pin TNC connector
Max. power	10 W (FCC/IC: 2.5 W)
Antenna cable length	3.3 m
Shock resistant according to EN 60721-3-7 Class 7M2 Total shock response spectrum Type II	30 g
Vibration according to EN 60721-3-7 Class 7M2	1 g (9 to 200 Hz)/1.5 g (200 to 500 Hz)
Attachment of the antenna	4 x M6 screws
Ambient temperature	
• Operation	• -20 °C to +55 °C
• Transport and storage	• -25 °C to +70 °C
MTBF	3 x 10 ⁵ hours
Degree of protection according to EN 60529	IP65 (UL: for indoor use only)
Weight, approx.	3.3 kg
Approvals	<ul style="list-style-type: none"> • CE • FCC • IC • Harmless to heart pacemakers • UL 60950

8.3.4 Transmission window

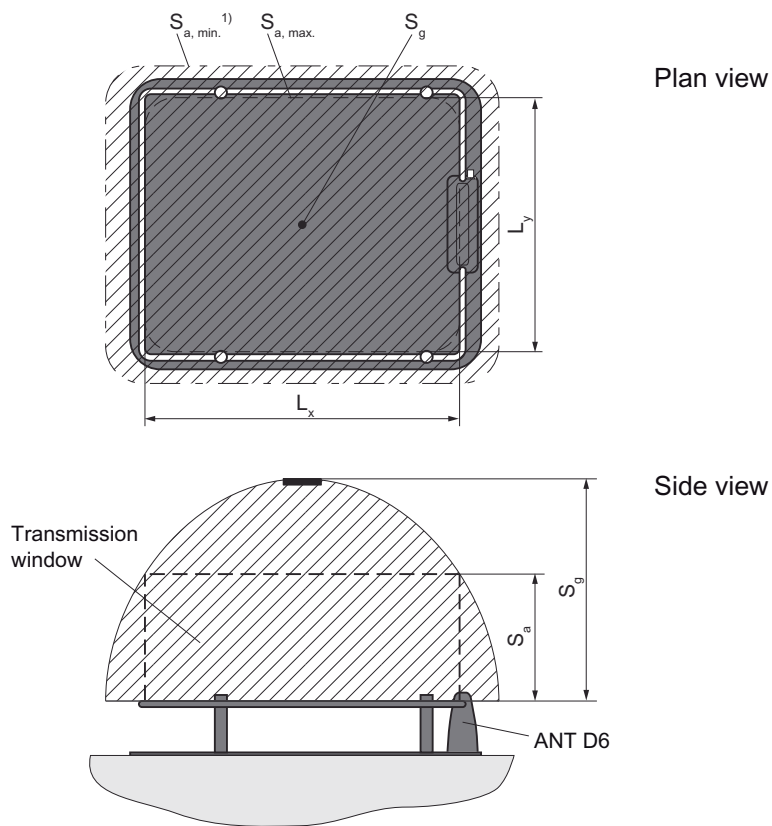

1) For $S_{a, min.}$, the transmission window is extended

$L_x = 520$ mm

$L_y = 420$ mm

Figure 8-11 Transmission window for ANT D6

8.3.5 Metal-free area

Flush-mounted in metal

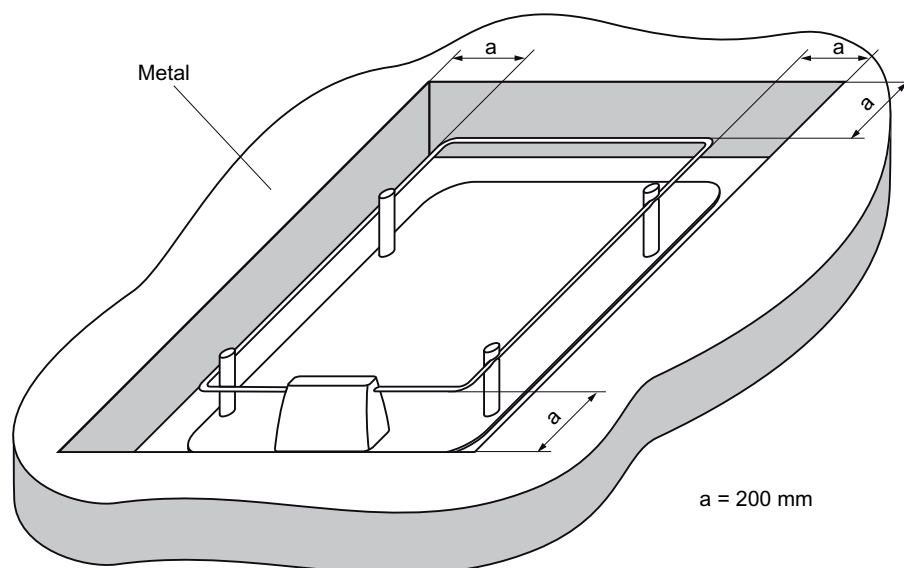

Figure 8-12 Metal-free area for ANT D6

8.3.6 Minimum distance between antennas

Definition of distance D

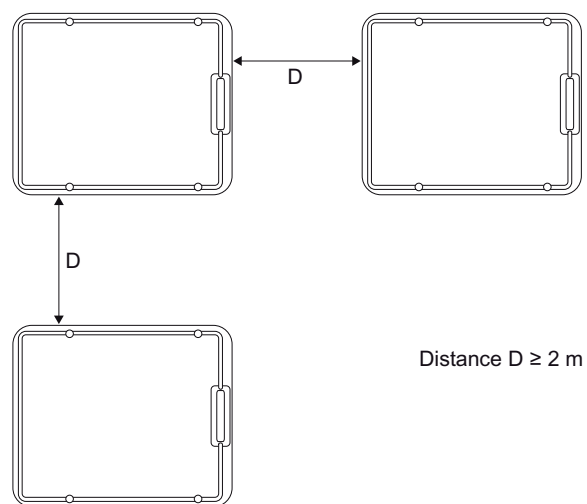

Figure 8-13 Distance D: ANT D6

8.3.7 Dimension drawing

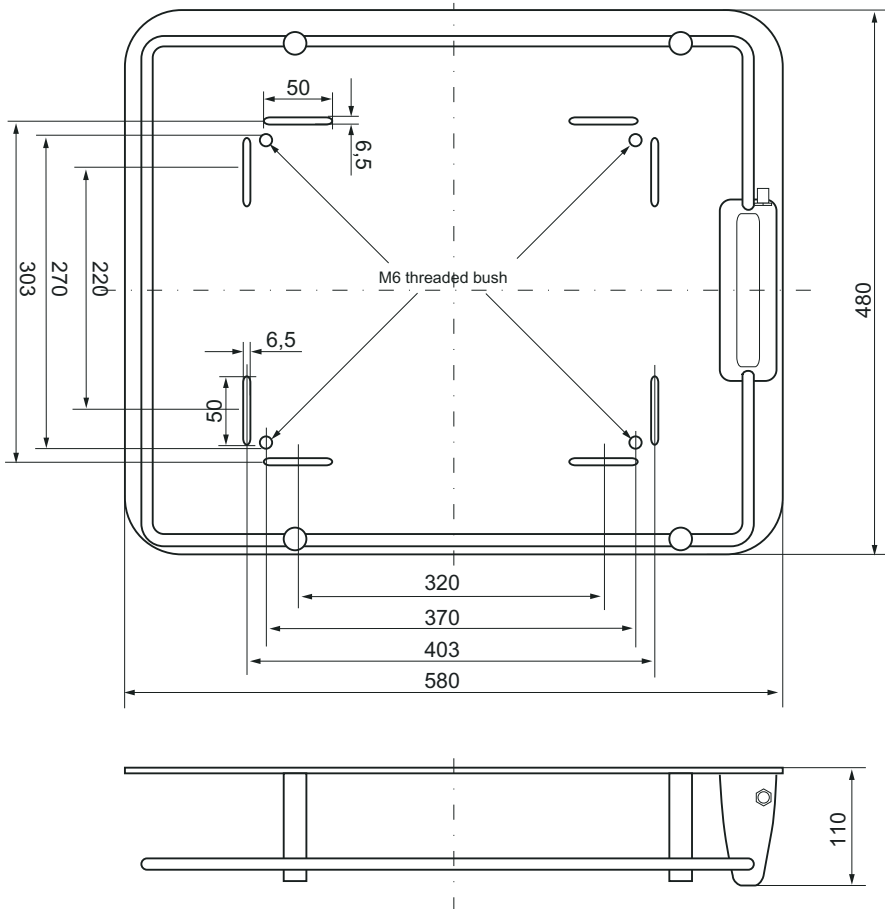



Figure 8-14 Dimension drawing for ANT D6

8.4 ANT D10

8.4.1 Features

ANT D10	Features	
	Applications	<ul style="list-style-type: none"> • Storage, logistics and distribution, e.g. clothing industry, laundries • Particularly when small MDS are used (e.g. MDS D124, MDS D160) and when there is a long transmission field
	Writing/reading distance	Up to 480 mm (depending on MDS)
	Connecting cable	3.3 m; included in scope of supply
	Covering hood	Available as accessory
	Connectable SLG	SLG D10/D10S

8.4.2 Ordering data

Table 8- 10 Ordering data of ANT D10

ANT D10	Order No.
<ul style="list-style-type: none"> • Dimensions L x W x H in mm: 1150 x 365 x 115 (with cover) • Antenna cable included in scope of supply 	6GT2698-5AF00

Table 8- 11 Ordering data of ANT D10 accessories

Accessories	Order No.	
Antenna duplexer (with 1 antenna connecting cable 3.3 m)	6GT2690-0AC00	
Antenna cable	Length 3.3 m	6GT2691-0CH33
	Length 10.5 m	6GT2691-0CN10
Antenna extension, length 7.2 m	6GT2691-0DH72	

8.4.3 Technical data

Table 8- 12 Technical specifications for ANT D10

Max. write/read distance ANT to MDS (S _g)	480 mm
Dimensions in mm (L x W x H)	1150 x 365 x 115 (with cover)
Color	Gray/black
Material	Aluminum/plastic
Plug connection	1-pin TNC connector
Max. power	10 W (FCC/IC: 2.5 W)
Antenna cable length	3.3 m
Shock resistant according to EN 60721-3-7 Class 7M2 Total shock response spectrum Type II	30 g
Vibration according to EN 60721-3-7 Class 7M2	1 g (9 to 200 Hz)/1.5 g (200 to 500 Hz)
Attachment of the antenna	4 x M6 screws
Ambient temperature	
• Operation	• -20 °C to +55 °C
• Transport and storage	• -25 °C to +70 °C
MTBF	3 x 10 ⁵ hours
Degree of protection according to EN 60529	IP65 (UL: for indoor use only)
Weight, approx.	10 kg (with cover)
Approvals	<ul style="list-style-type: none"> • CE • FCC • IC • Harmless to heart pacemakers • UL 60950

8.4.4 Transmission window

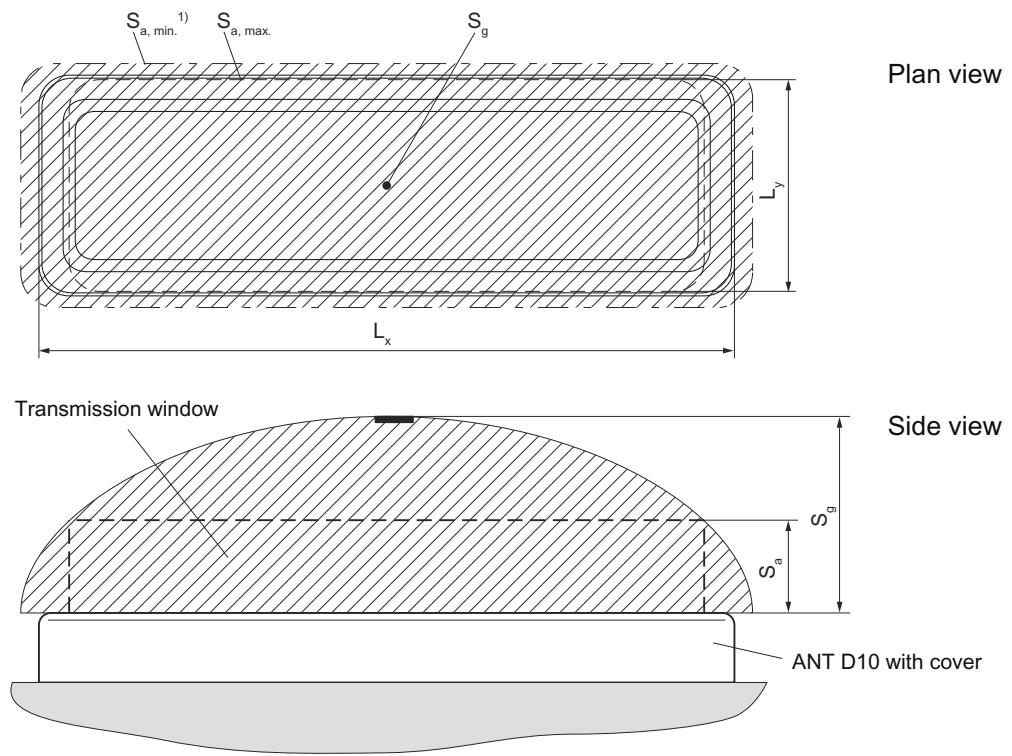

¹⁾ For $S_{a, min.}$ the transmission window is extended

L_x 1050 mm

L_y 350 mm

Figure 8-15 Transmission window for ANT D10

8.4.5 Metal-free area

Flush-mounted in metal

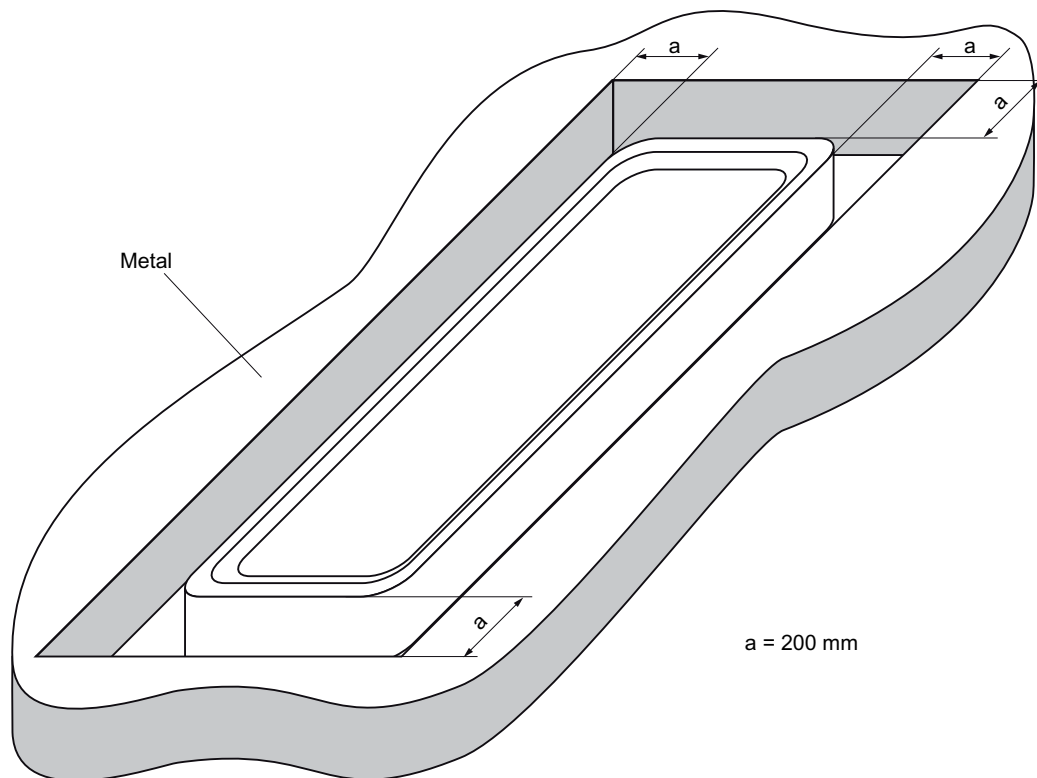

Figure 8-16 Metal-free area for ANT D10

When installing in the vicinity of metal, observe the instructions in the Section .

8.4.6 Minimum distance between antennas

Definition of distance D

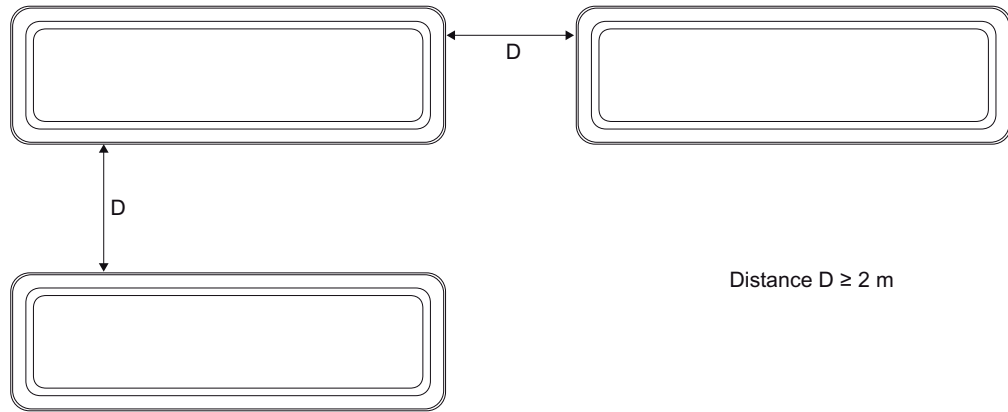

Figure 8-17 Distance D: ANT D10

8.4.7 Dimension drawing

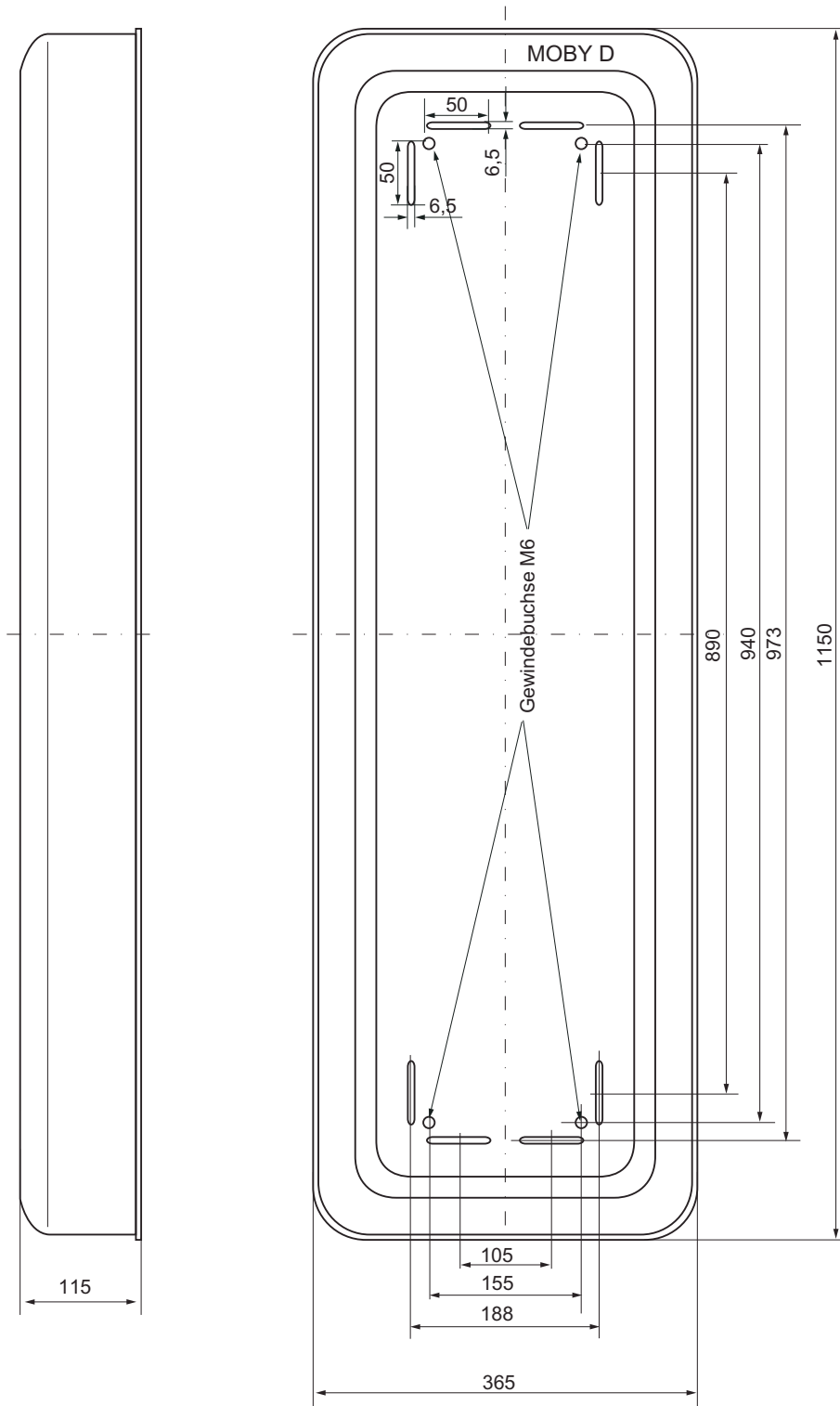

Figure 8-18 Dimension drawing for ANT D10

System integration

Application area

The ASM interface modules are links between the MOBY D components SLG/MDS and the higher-level control systems (e.g. SIMATIC S7) or PC or computers. Depending on the interface module used, up to two SLGs can be connected.

Design and functions

The ASM comprises a microcontroller system with an individual program (PROM). The CPU receives commands over the user interface and saves them in RAM. The user receives an acknowledgement that the command has arrived. If the command is valid, the CPU starts to process it.

Overview

Table 9- 1 Overview of interface modules

ASM type	Interfaces to PC/computer	Interfaces to SLG	Function blocks	SLG connections	Dimensions (W x H x D in mm)	Temperature range (during operation)	Degree of protection
ASM 452	PROFIBUS DP-V1	2 x 5-pin BERO connector	FC 45	1	134 x 110 x 55	0 to +55 °C	IP67
ASM 456	PROFIBUS DP-V1	2 x 8-pin connection socket, M12	FC 45 FB 45 FC 55 FB 55	2 (simultaneously)	60 x 210 x 54 or 79	0 to +55 °C	IP67
ASM 473	For inserting in ET 200X	2 x 5-pin BERO connector	FC 45	1	87 x 110 x 55	0 to +55 °C	IP67
ASM 475	For inserting in S7-300/ET 200M	Through screw-type terminals	FC 45	2 (simultaneously)	40 x 125 x 120	0 to +60 °C	IP20
RF170C	Can be plugged into ET 200pro	8-pin M12 connector	FC 45 FB 45 FC 55 FC 56	2 (simultaneously) ¹⁾	90 x 130 x 60	-25 to +55 °C	IP67
RF180C	PROFINET	8-pin M12 connector	FB 45	2 (simultaneously) ¹⁾	60 x 210 x 30	0 to +60 °C	IP67
RF182C	TCP/IP	2 x 8-pin connection socket, M12	--	2 (simultaneously) ¹⁾	60 x 210 x 30	0 to +60 °C	IP67

¹⁾ If 2 readers are used on one ASM, the following restrictions apply:

- The maximum operating temperature is 35 °C
- The input voltage is 24 V ±10%

Current consumption ≤ 425 mA per reader

9.1 ASM 452

9.1.1 Application area

The ASM 452 interface module is a MOBY module for operating MOBY components over PROFIBUS DP-V1 on

- Any computers and PCs
- Any PLCs

When operating the interface module on a SIMATIC S7, function blocks are made available to the user.



Figure 9-1 ASM 452 interface module

9.1.2 Features

The ASM 452 is the result of consistent development of the familiar ASM 450 interface modules. Optimal data throughput can be achieved even in large-scale PROFIBUS configurations thanks to the use of acyclic data traffic on PROFIBUS DP V1. The minimum cyclic data load of the ASM 452 on the PROFIBUS DP provides the user with the guarantee that other PROFIBUS nodes (e.g. DI/DO) can still be processed at great speed.

The ASM 452 is an interface module for communication between PROFIBUS DP and the SLG D1xS with RS 422. The data on the MDS D139/D160 can be physically addressed ("standard" addressing) through the ASM 452.

In SIMATIC S7, FC 45 is available for "standard" addressing.

The FC 45 provides the S7 user with an interface with powerful commands that is easy to operate. FC 45 also offers command concatenation (not with SLG D11S ANT D5 and SLG D12S) and S7 data structures with UDTs.

9.1.3 Configuration

Hardware description

The ASM 452 has the same housing as the distributed I/O system ET 200X. General information on ASM 452 (e.g. assembly, operation and wiring; general technical data) is available in the ET200X manual (Order No. 6ES7198-8FA00-8AA0). Descriptions of accessories and network components can also be found in this manual.

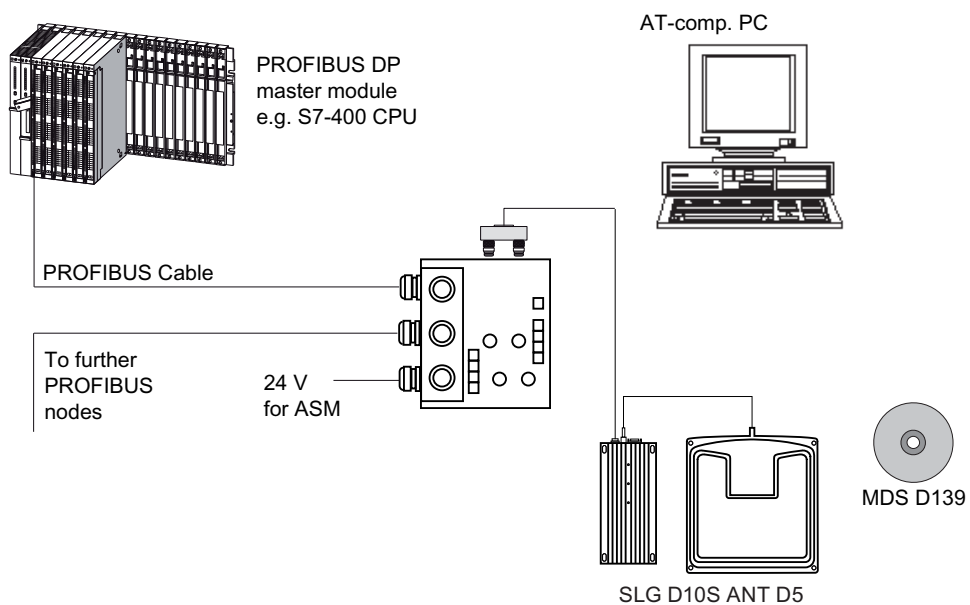

Figure 9-2 ASM 452 configurator

9.1.4 PROFIBUS DP communication

9.1.4.1 PROFIBUS DP configuring

The ASM 452 is integrated into the hardware configuration by means of a GSD file. The ASM can then be configured using the HW Config of SIMATIC Manager or another PROFIBUS DP tool.

A GSD file is provided for ASM 452 on the "MOBY software" CD.

9.1.4.2 Operating mode of the ASM 452

The approved operating modes of ASM 452 are described in the GSD file. It is set using the hardware configuration tool (e.g. STEP 7 HW Config).

9.1.4.3 PROFIBUS DP diagnostics

The following table lists possible error indications with their meanings and provides remedies.

Table 9- 2 LED indication for PROFIBUS DP diagnostics

"BF" LED	"SF" LED	Cause of error	Error management
On	*	<ul style="list-style-type: none"> ASM 452 is in start-up mode. 	-
		<ul style="list-style-type: none"> Communication to the DP master is down. ASM 452 not detecting a baud rate. 	<ul style="list-style-type: none"> Check the PROFIBUS DP connection. Check the DP master.
		<ul style="list-style-type: none"> Bus interruption DP master is out of service 	<ul style="list-style-type: none"> Check all cables on your PROFIBUS DP network. Check whether the connector plugs for PROFIBUS DP are securely plugged into the ASM 452.
flashes	On	<ul style="list-style-type: none"> The configuration data sent to the ASM 452 by the DP master do not match the configuration of the ASM 452. 	<ul style="list-style-type: none"> Check the configuration of the ASM 452 (input/output, PROFIBUS DP address). Correct GSD file being used? <ul style="list-style-type: none"> – SIEM80B6.GSD for ASM 452
flashes	off	<ul style="list-style-type: none"> ASM 452 has detected the baud rate, but is not being addressed by the DP Master. ASM 452 has not been configured. 	<ul style="list-style-type: none"> Check the PROFIBUS DP address set on the ASM 452 or in the configuration software. Check the configuration of the ASM 452 (station type).
On	flashes	<ul style="list-style-type: none"> There is a hardware defect in the ASM 452. 	<ul style="list-style-type: none"> Replace the ASM 452.

9.1.4.4 PROFIBUS DP address and terminating resistor

You must remove the connector plate from the ASM before you set the PROFIBUS DP address or connect the terminating resistor. The connector plate covers the DIL switch. The position of the DIL switch in ASM is shown in the figure below with one setting example for each case.

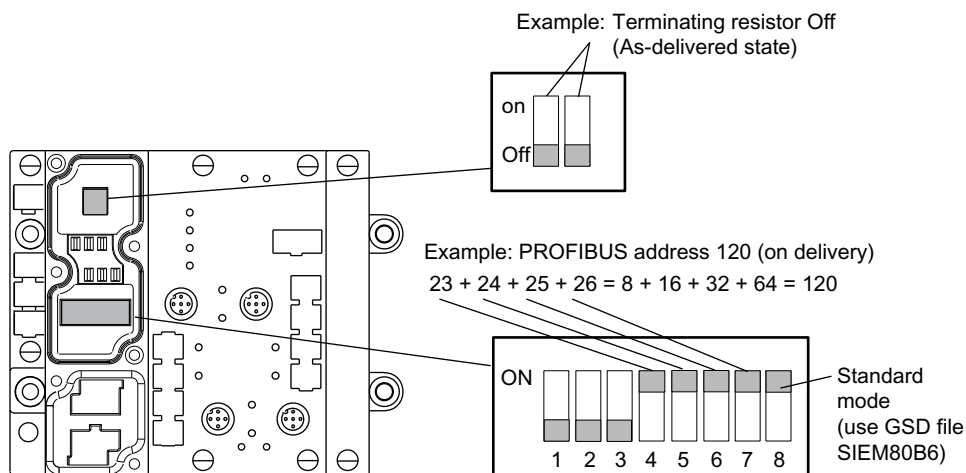

Figure 9-3 Setting the PROFIBUS DP address/connecting the terminating resistor

Note

- The PROFIBUS DP address in ASM 452 must always match the PROFIBUS DP address defined in the configuring software for this ASM.
- To ensure that the terminating resistor functions correctly, you must always switch **both** DIL switches of the terminating resistor to "on" or "off".

9.1.5 Device connections

9.1.5.1 Reader connection system

An SLG always occupies two M12 connector sockets on the ASM 452. A pre-assembled cable therefore ensures easy connection of the SLG (see figure below). The standard version of the connection cable is 2 m in length, other lengths of 5 m and 20 m are available.

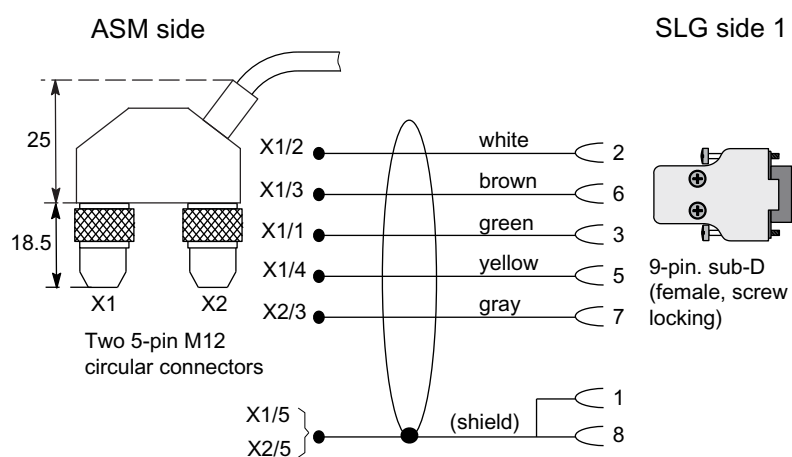

1 Caution:

When metal Sub D casings are used on the SLG side, the casing must be connected to the cable shield.

Figure 9-4 Connecting cable ASM 452/473 ↔ SLG D1xS with RS 422 (6GT2491-1CH20)

An SLG cable connector with screw-type terminals is provided for users who want to individually pre-assemble their own cables (see figure below). Cables and SLG cable connectors can be ordered from the MOBY catalog.

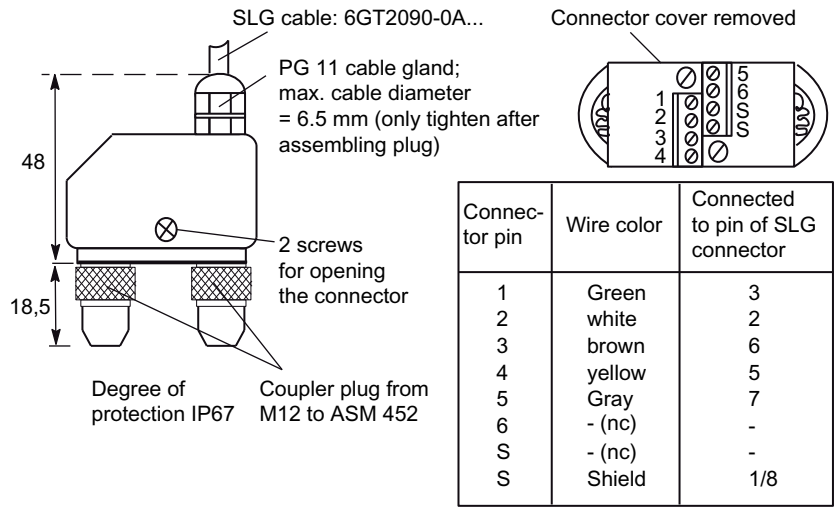

Figure 9-5 Cable connector ASM 452/473 ↔ SLG D1xS with RS 422 (6GT2090-0BC00)

9.1.5.2 Pin assignments

The figure below illustrates the pin assignments of ASM 452.

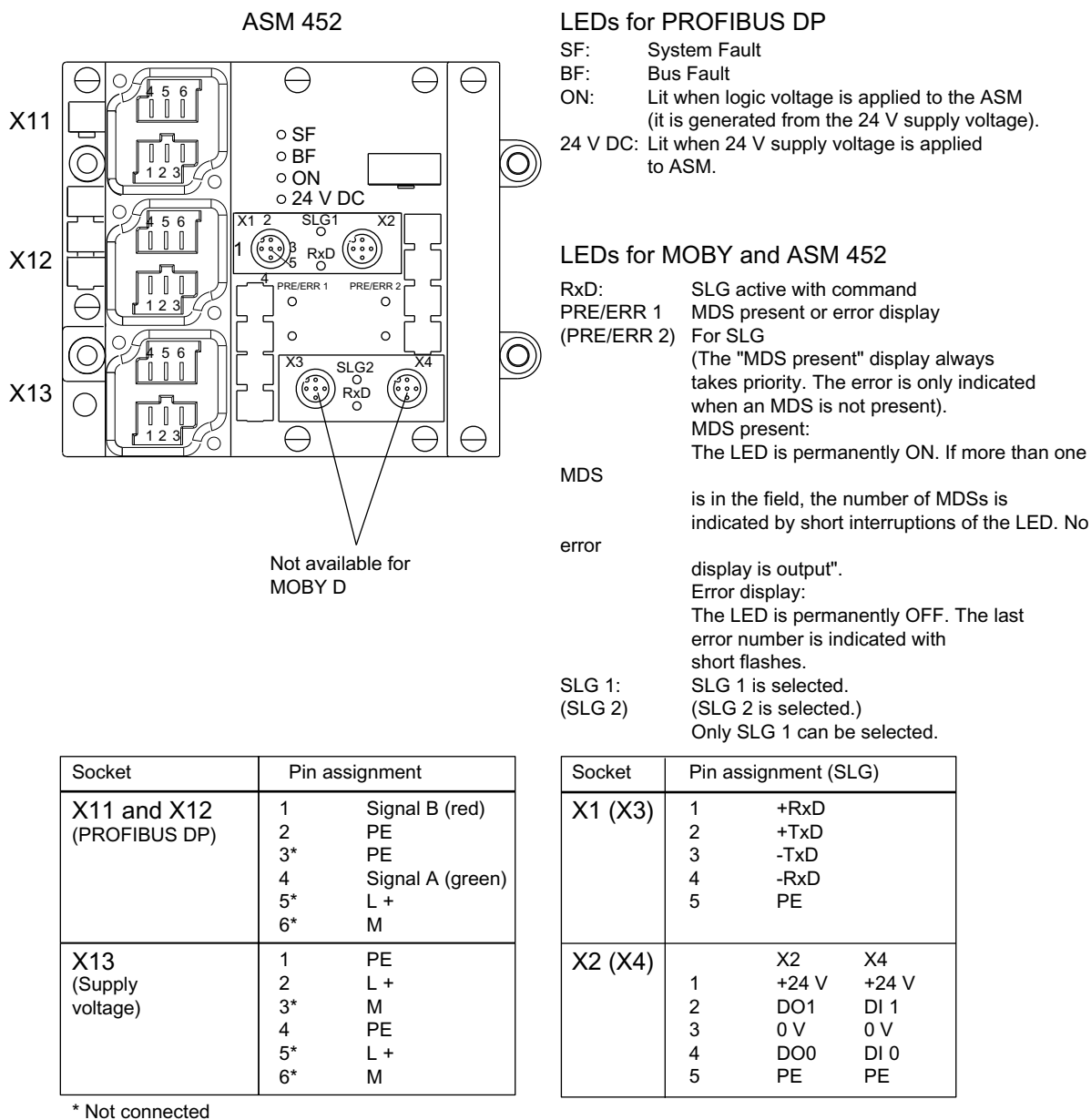

Figure 9-6 Pin assignment and LEDs of ASM 452

Note

With MOBY D, the SLG power supply cannot be connected through the ASM.

9.1.6 Cable

9.1.6.1 PROFIBUS DP cable with 24 V supply

The ASM 452 can also be operated with the "green" PROFIBUS DP cable. It is important to ensure that a 24 V cable is connected from X12 to X13. The 24 V cable can be connected to pins 5 and 6 in plug X12.

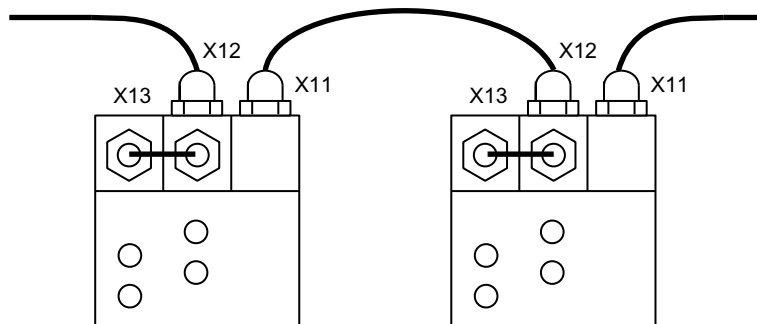

Figure 9-7 PROFIBUS DP cable with 24 V supply

9.1.6.2 Example of stripped lengths

The following diagram shows an example of stripped lengths. The lengths apply to all cables which can be connected to the connector plugs. You must twist any shield braid present, plug into a core end sleeve and cut off any excess.

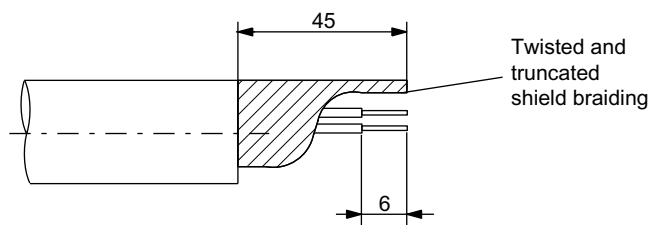

Figure 9-8 Length of stripped insulation for PROFIBUS DP cables

9.1.7 Technical data

Table 9- 3 Technical specifications for ASM 452

ASM 452 with FC 45	
Serial interface to the user	PROFIBUS DP-V1
Procedure after connection	EN 50170 Vol. 2 PROFIBUS DP PG 11 cable gland PROFIBUS DP and power supply connectors are not included in the scope of delivery
Data transfer rate	9600 baud to 12 Mbaud (automatic detection)
Max. block length	2 words cyclic/240 bytes acyclic
Serial interface to write/read device	
Connectors	2 x M12 coupler plug
Max. cable length	2 m = Standard length; other preassembled cables: 5 m, 20 m (to 1000 m on request)
Connectable SLGs	1x SLG D1xS with RS 422
Software functions	
Programming	Depending on the PROFIBUS DP master
Function blocks for SIMATIC S7	FC 45
MDS addressing	Direct access via addresses
Commands	Initialize MDS, read data from MDS, write data to MDS, etc.
Multi-tag capability	no
S7 data structures via UDTs	Yes
Power supply ¹	
• Rated value	24 V DC
• Permitted range	20 V to 30 V DC
• Current consumption	Max. 180 mA; typ. 130 mA (without SLG, no load on DO)
Digital Inputs	None
Digital outputs	None
Ambient temperature	
• Operation	0 to +55°C
• Transport and storage	-40 °C to +70 °C
Dimensions (W x H x D) in mm	134 x 110 x 55 (without bus connector)
Mounting technique	4 M5 screws; for mounting on any plate or wall
Weight, approx.	0.5 kg
Degree of protection	IP67
MTBF (at 40 °C)	30 • 104 hours = 34 years
1) With MOBY D, the SLG power supply cannot be connected through the ASM.	

9.1.8 Dimension diagram

The following figure shows the dimensional drawing of an ASM 452 with bus connectors. You must add the length of the PG cable gland and the radius of the cable used to the measured overall width and depth.

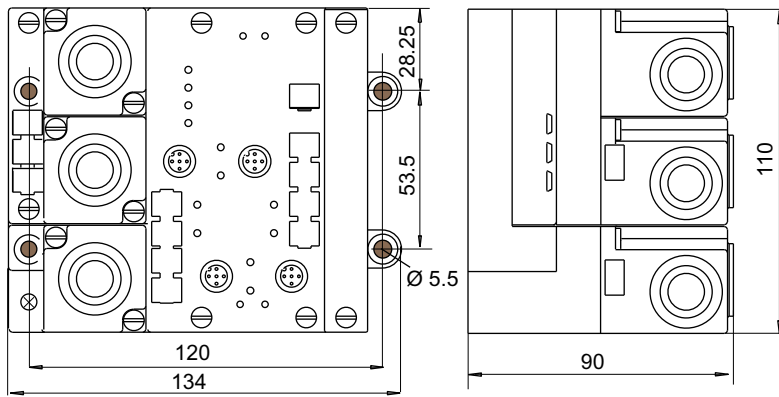

Figure 9-9 Dimensional drawing of ASM 452

9.1.9 Ordering data

Table 9- 4 Ordering data for ASM 452

Designation	Order No.
ASM 452 interface module for PROFIBUS DP-V1 1x SLG D1xS with RS 422 can be connected	6GT2002-0EB20
Accessories:	
Connector for PROFIBUS DP and 24 V supply	6ES7194-1AA01-0XA0
SLG cable ASM 452 ↔ SLG D1xS	
Length 2 m; standard cable	6GT2491-1CH20
Other lengths:	
• 5 m	6GT2491-1CH50
• 20 m	6GT2491-1CN20
Opt. Cable connector without SLG cable (for cable lengths > 20 m) ASM 452 ↔ SLG	6GT2090-0BC00
M12 blanking cap for unused SLG connection (1 pack = 10 pieces)	3RX9802-0AA00
CD <i>RFID Systems Software & Documentation</i> with FC 45, GSD file	6GT2080-2AA10
FC 45 Reference Manual German English French	Available in electronic form on the CD <i>RFID-Systems Software & Documentation</i>
Connector plate; T functionality for PROFIBUS DP connection	6ES7194-1FC00-0XA0

9.2 ASM 456

Configured with ASM 456

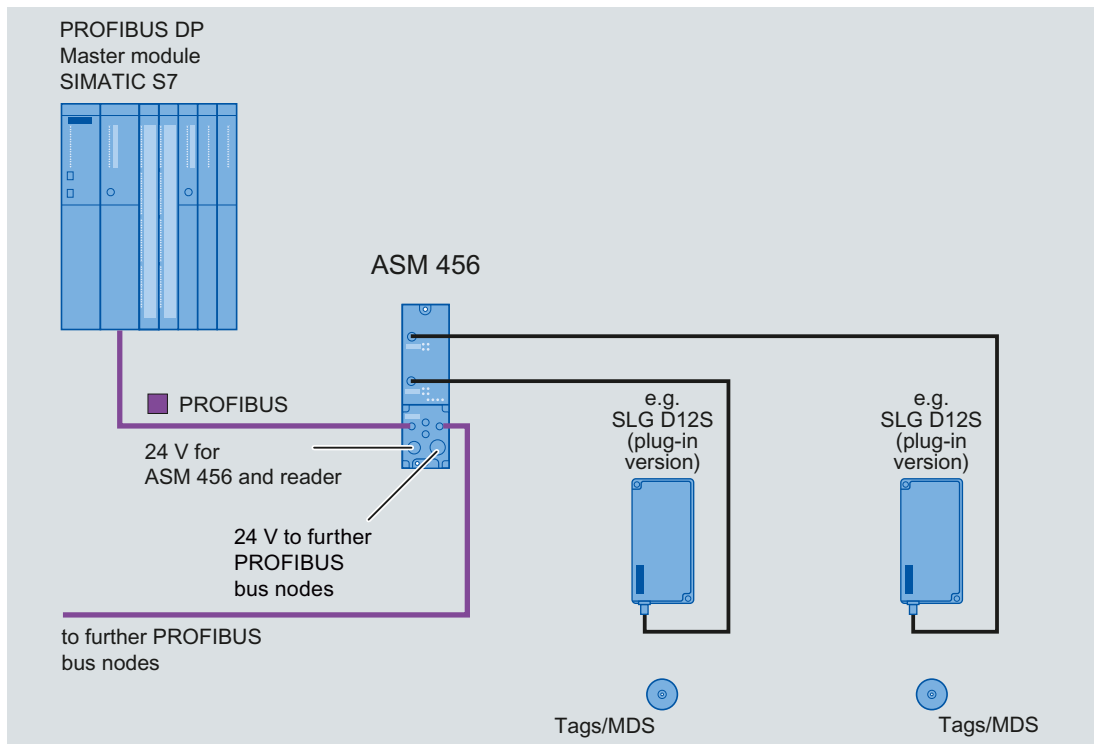

Figure 9-10 Configuration of ASM 456

For more detailed information, refer to ASM 456 Operating Instructions (<http://support.automation.siemens.com/WW/view/en/32629442>).

9.3 ASM 473

9.3.1 Application area

The ASM 473 interface module is a MOBY module for SIMATIC S7. It can be plugged into the ET 200X distributed I/O station and DESINA. ET 200X is operated by the user over PROFIBUS DP V1. An S7-300 or S7-400 with integrated PROFIBUS DP connection can be used as the controller.



Figure 9-11 ASM 473 interface module

9.3.2 Features

ASM 473 supplements the SIMATIC S7 MOBY interface module ASM 475. The IP67 degree of protection means that it can be installed and operated in the process without the need for an additional protective housing.

To operate the ASM 473, an ET 200X basic module BM 141/142 with the order number 6ES7141-1BF11-0XB0 or 6ES7142-1BD21-0XB0 or a BM 143 is required.

The MDS data are accessed by means of physical addressing of the MDS.

For operation in a SIMATIC S7, the function FC 45 is available. The hardware of the ASM 473 is configured with an object manager (OM) that is integrated in the SIMATIC Manager.

Other features:

- Up to 7 ASM 473 interface modules can be operated simultaneously in an ET 200X station.
- Any other I/O modules from the ET 200X spectrum can be operated with the ASM 473.

9.3.3 Basic module - Requirements for operation of ASM 473

The following table indicates the status of the ET 200X basic module of 10/2002. The functionality of new basic modules is stored in HW Config of the SIMATIC Manager.

Table 9- 5 Requirements for operation of ASM 473

Order number of the ET 200X basic module	For operation with ASM 473 (6GT2002-0HA00)*	For operation with ASM 473 PARAM (6GT2002-0HA10)
6ES7141-1BF00-0XB0	no	no
6ES7141-1BF00-0AB0	Yes	Yes
6ES7141-1BF01-0XB0	no	no
6ES7141-1BF10-0XB0	no	no
6ES7141-1BF11-0XB0	Yes	Yes
6ES7141-1BF40-0AB0	Yes	Yes
6ES7142-1BD10-0XB0	no	no
6ES7142-1BD11-0XB0	no	no
6ES7142-1BD20-0XB0	no	no
6ES7142-1BD21-0XB0	Yes	Yes
6ES7142-1BD22-0XB0	no	Yes**
6ES7143-1BF00-0AB0	Yes	Yes
6ES7143-1BF00-0XB0	Yes	Yes
6ES7147-1AA00-0XB0	no	no
6ES7147-1AA01-0XB0	no	Yes
* Discontinued		
** Notes on operation: In HW Config, please parameterize the module 6ES7142-1BD21-0XB0.		

9.3.4 Configuration

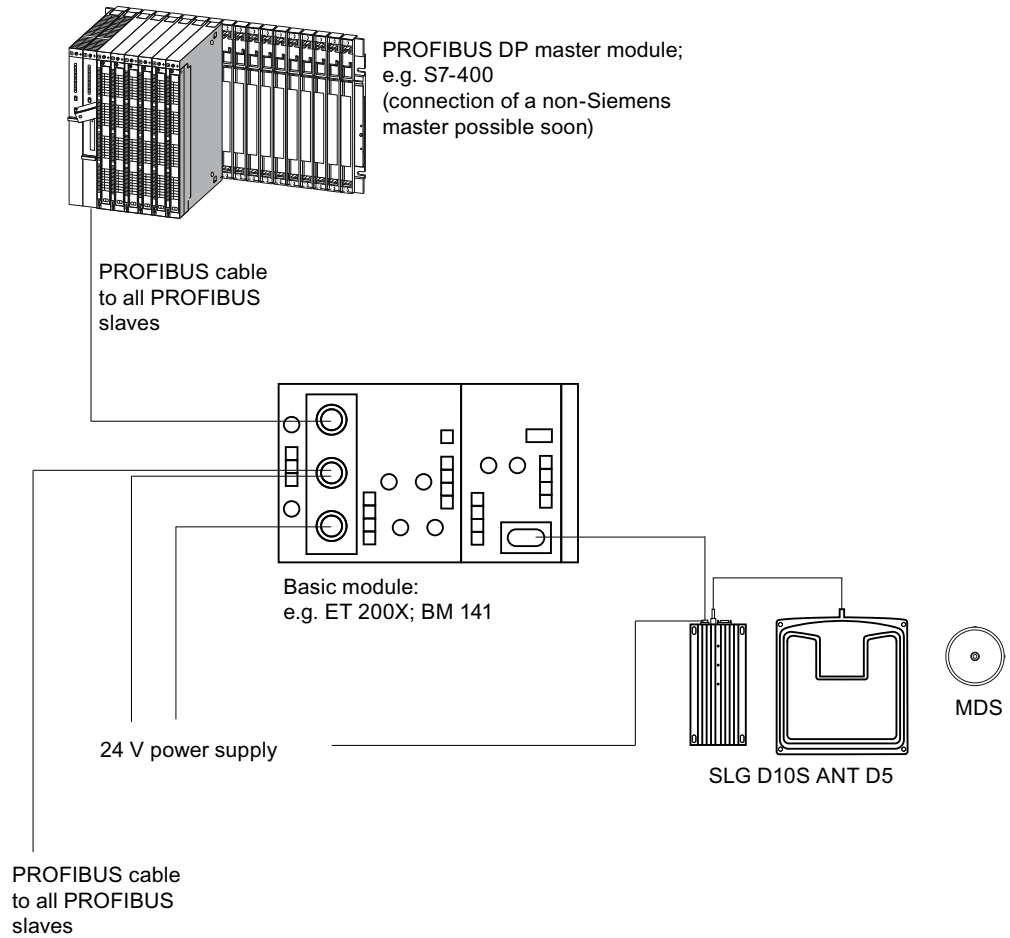

Figure 9-12 Configurator for ASM 473

Note

It differs from ASM 452 in that for ET 200X the 24 V supply must be connected to the PROFIBUS DP connector **and** to the load voltage connector (see the ET 200X manual).

maximum configuration

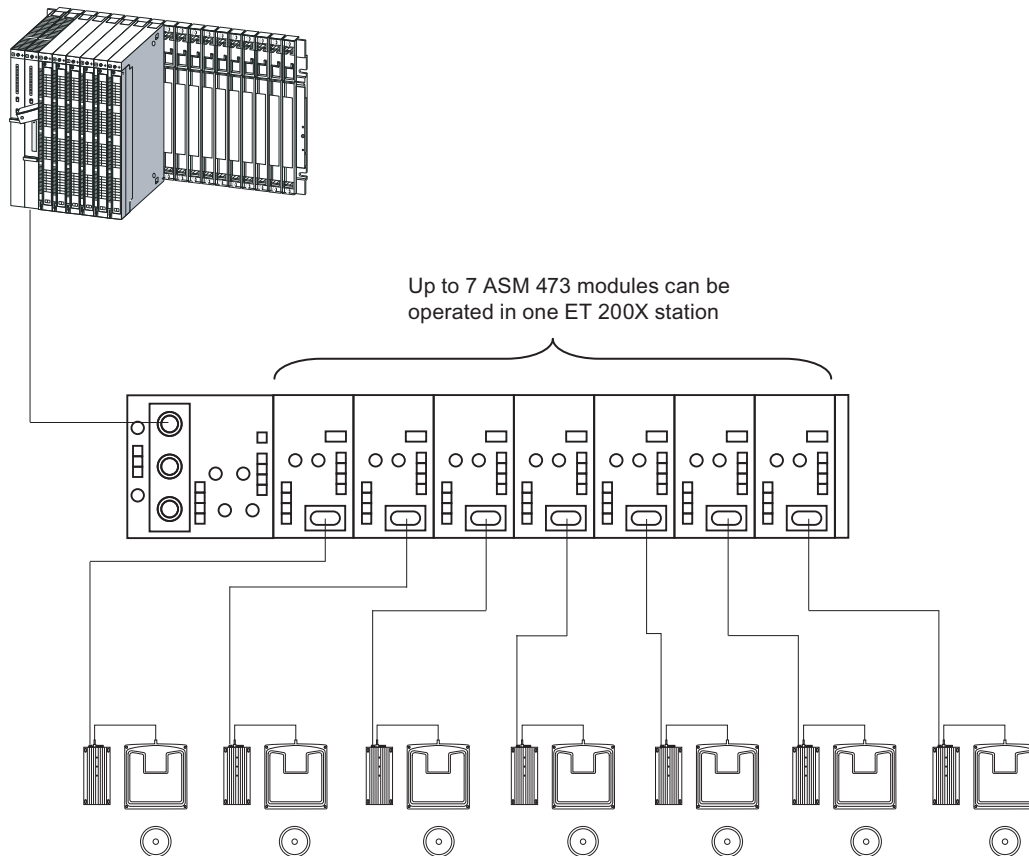

Figure 9-13 Maximum configuration of ASM 473 on an ET 200X

Depending on the PROFIBUS DP master, up to 123 ET 200X modules can be run on one PROFIBUS DP segment.

Hardware configuration

The ASM 473 is integrated in the hardware configuration of the SIMATIC Manager by calling Setup.exe in the directory daten\S7_OM on the "Software MOBY" CD. Currently, the ASM 473 cannot be integrated in masters of other manufacturers.

9.3.5 Device connections

9.3.5.1 Reader connection system

A write/read device always occupies the two M12 connection sockets X3 and X4 on the ASM 473. A prefabricated cable makes it easy to connect the write/read device. The standard version of the connecting cable is 2 m in length. Other cable lengths are available on request.

For customers who want to assemble their own cables, an SLG cable connector with screw-type terminals is available. Cables and SLG cable connectors can be ordered from the MOBY catalog.

9.3.5.2 Pin assignments

The figure below illustrates the pin assignment for the write/read device and the display elements.

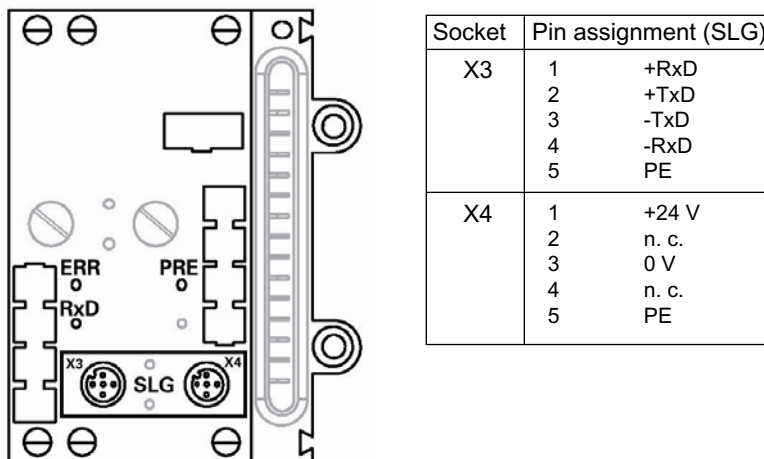

LEDs for PROFIBUS DP

General indicators (SF, BF, ON, 24VDC) are located on the basic module of the ET 200X.

LEDs for MOBY

- RxD: SLG active with command
- PRE: Indicates the presence of an MDS.
- ERR: Error indicated by flashing sequence

The following ASM states are also indicated with the LEDs "PRE" and "ERR":

PRE	ERR	Description, causes, rectification
OFF/ON	ON (perm.)	Hardware is defective (RAM, flash,...)
ON	OFF	Charger is defective (can only be repaired in the factory).
2 Hz	OFF	Firmware loading is active or no firmware detected → Load firmware → ASM must not be switched off until loaded
2 Hz	2 Hz	Firmware loading terminated with errors → Restart required → Load firmware again → Check update files
5 Hz	5 Hz	Operating system error → Switch ASM or ET 200X base station OFF/ON
OFF	1 x flash every 2 s	ASM has booted and is waiting for a RESET (init_run) from the user

Figure 9-14 Interfaces and indicators of the ASM 473

Note

With MOBY D, the SLG power supply cannot be connected through the ASM.

9.3.6 Technical data

Table 9- 6 Technical specifications for ASM 473

Interface for ET 200X	SIMATIC S7 I/O bus cyclic/acyclic services
Communication	2 words cyclic/238 bytes acyclic
Command buffer in ASM	142 x 238 bytes
Serial interface to write/read device	
<ul style="list-style-type: none"> Connectors Max. cable length 	<ul style="list-style-type: none"> 2 x M12 coupler plug 2 m = standard length; other pre-assembled cables = 5 m, 20 m (up to 1000 m on request) 1 x SLG D1xS with RS 422
Connectable SLGs	
Connectors	2 x M12 coupler plug
Max. cable length	2 m = standard length; other pre-assembled cables = 5 m, 20 m (up to 1000 m on request)
Connectable SLGs	1 x SLG D1xS with RS 422
Software functions	
Programming	Depending on the PROFIBUS DP master
Function blocks for SIMATIC S7	FC 45
MDS addressing	Direct access via addresses
Commands	Initialize MDS, read data from MDS, write data to MDS, etc.
PROFIBUS DP diagnostics	Yes; in accordance with ET 200X basic station
S7 diagnostics	Yes, can be called up via S7 OM
Reloadable firmware	Yes, via S7 OEM
Power supply ¹	
<ul style="list-style-type: none"> Rated value Permitted range 	<ul style="list-style-type: none"> 24 V DC 20.4 V to 28.8 V DC
Current consumption	Typ. 75 mA; max. 500 mA (or see Technical Data of the connected SLG)
Power dissipation of the module	Typ. 1.6 W
Digital outputs/inputs	Via expansion modules from the ET 200X spectrum
Ambient temperature	
<ul style="list-style-type: none"> Operation Transport and storage 	<ul style="list-style-type: none"> 0 to +55°C -40 to +70°C
Dimensions (W x H x D) in mm	
<ul style="list-style-type: none"> Single unit Width module 	<ul style="list-style-type: none"> 87 x 110 x 55 60 x 110 x 55
Mounting technique	2 M5 screws (customer side) 2 M3 screws (product side)
Degree of protection	IP67

Weight, approx.	0.275 kg
-----------------	----------

1) With MOBY D, the SLG power supply cannot be connected through the ASM.

Assembly instructions as well as general technical data can be found in the *ET 200X manual* (Order No. 6ES7 198-8FA01-8AA0).

9.3.7 Dimension diagram

Dimensioned Drawing for Fixing Holes

The figure below shows the dimensions for the position of the holes for the fixing screws for a basic module and an ASM 473 expansion module.

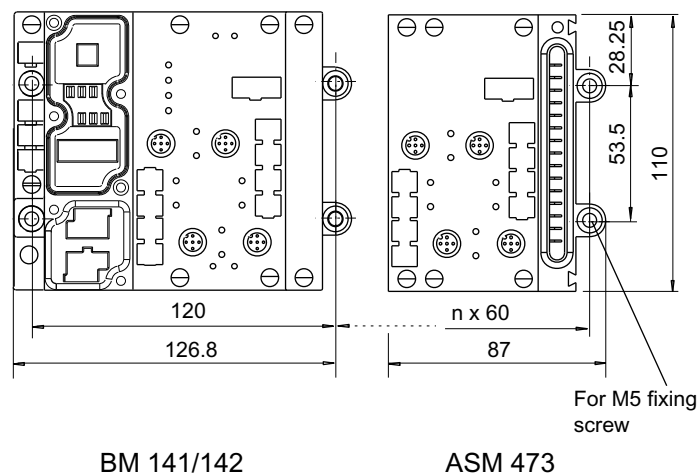

n = Number of expansion modules

Figure 9-15 Dimensions for fixing holes for basic modules and expansion modules

9.3.8 Ordering data

Table 9- 7 Ordering data for ASM 473

	Order No.
ASM 473 interface module 1x SLG D1xS with RS 422 can be connected	6GT2002-0HA10
Accessories:	
SLG cable ASM 473 ↔ SLG D1xS	
Length 2 m; standard cable	6GT2491-1CH20
Other lengths:	
• 5 m	6GT2491-1CH50
• 20 m	6GT2491-1CN20
Opt. Cable connector without SLG cable ASM 473 ↔ SLG (for cable lengths > 20 m)	6GT2090-0BC00
CD <i>RFID Systems Software & Documentation</i> with FC 45, GSD file	6GT2080-2AA10
FC 45 Reference Manual German English French	Available in electronic form on the CD <i>RFID Systems Software & Documentation</i>

9.4 ASM 475

9.4.1 Application area

The ASM 475 interface module can be inserted in SIMATIC S7-300 and ET 200M and can be used for all MOBY systems.

As many as eight ASM 475 interface modules can be plugged into one SIMATIC S7-300 rack and operated. In a configuration with several racks (max. four), the ASM 475 can be plugged into and operated on any rack. This means that as many as 32 ASMs can be operated in the maximum configuration of a SIMATIC S7-300. The ASM can also be operated in the ET 200M distributed I/O on PROFIBUS DP. Operation in an S7-400 environment is therefore problem-free. Up to 8 ASMs can be operated on each ET 200M.



Figure 9-16 ASM475 interface module

FC 45 with project example

You can load the FC with a project example from the corresponding subdirectory on the CD *RFID Systems Software & Documentation* using the "Dearchive file" function of SIMATIC Manager. You will then find the project example in the S7PROJ directory of SIMATIC Manager.

Directory in <i>RFID Systems Software & Documentation</i>	SIMATIC Manager project name	SIMATIC Manager path name
FC 45	MOBY FC45	Moby_f_l

9.4.2 Features

Error messages and operating states are indicated by LEDs.

A configuration that is resistant to interference is possible due to electrical isolation between the write/read device and the SIMATIC S7-300 bus.

The ASM 475 with the order number 6GT2002-0GA10 is a parameterizable module. The basic functions of the module are then already specified when the module is configured in HW Config (e.g. standard addressing).

The data in the MDS is accessed direct by means of physical addresses using the ASM 475. Operation in a SIMATIC S7 is controlled by the function FC 45.

ASM 475 and FC 45 form a unit that is used for reading the data of the MDS easily and at optimal speed. A 32 KB MDS memory can be read in 24 seconds almost totally independently of the S7 cycle time.

9.4.3 Configuration

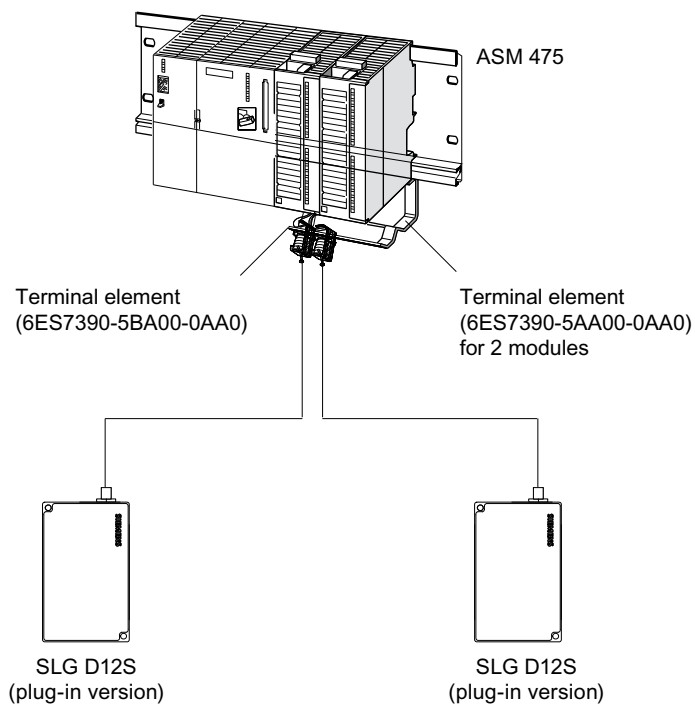

Figure 9-17 Configuration for ASM 475 (centralized layout)

wiring

The ASM 475 is started up as follows:

1. Install the module
2. Install the module on the standard rail of the S7-300
(see the *S7-300 manual*)

Note

Before the module is mounted, the CPU of the S7-300 must be switched to the STOP state.

 WARNING
--

Always switch off power before you start wiring the S7-300.

Note

To ensure problem-free operation of ASM 475, it is essential that the ASM and the SIMATIC CPU (or ASM and IM 153 for ET 200M operation) are operated with the same supply voltage.

If this is not the case, when the ASM is switched on, it is possible that error flags on the CPU will not be reset.

Configuring the ASM for SIMATIC S7 under STEP 7

Note

For MOBY installation, STEP 7 software must be available for use on the PC/PG.

Please ensure that you use the most recent STEP 7 version.

ASM 475 is installed and configured in the SIMATIC controller using an installation program. The installation program is supplied on the CD *RFID-Systems Software & Documentation* (6GT2080-2AA10).

Installation

The installation instructions can be found on the CD *RFID Systems Software & Documentation*.

9.4.4 Configuration

Front panel

The figure below illustrates the bezel of the ASM 475 and the inside of the front door complete with the associated connection diagram. The write/read devices must be connected to the ASM in accordance with the connection diagram.

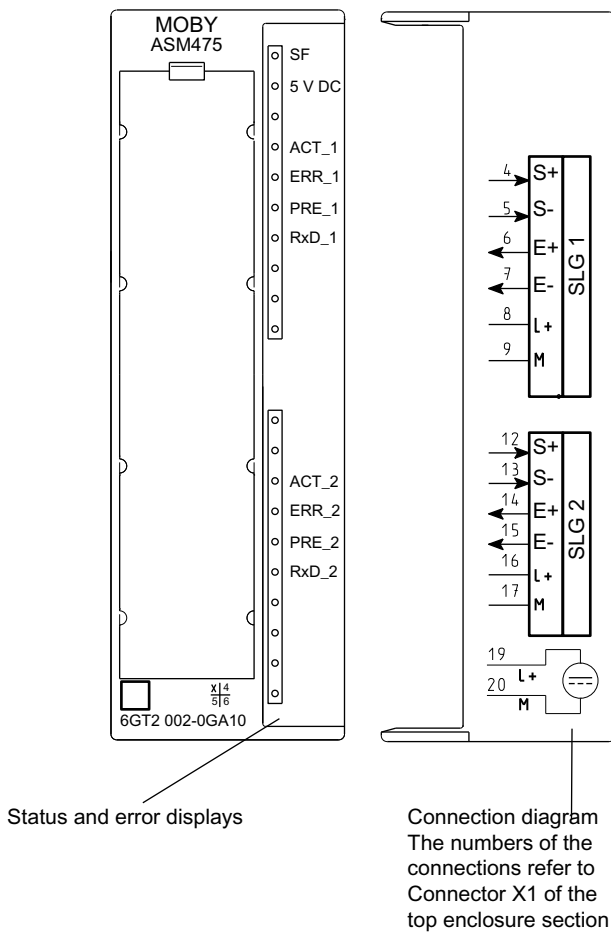

Figure 9-18 Bezel and inside of the front door of the ASM 475

Note

With MOBY D, the SLG power supply cannot be connected through the ASM (exception: SLG D12S (plug-in version)).

9.4.5 PROFIBUS DP communication

9.4.5.1 Diagnosis using LEDs

Display elements on the ASM

Table 9- 8 Function of the LEDs on the ASM 475

Light emitting diode	Meaning
SF	System fault (hardware error on ASM)
5 V DC	24 V are connected to the ASM and the 5 V voltage on the ASM is OK.
ACT_1, ACT_2	The corresponding write/read device is active in processing a user command.
ERR_1, ERR_2	A flashing pattern indicates the last error to occur. This display can be reset using the parameter Option 1.
PRE_1, PRE_2	Indicates the presence of an MDS.
RxD_1, RxD_2	Indicates continuous communication to the SLG. Faults on the SLG can also cause this indicator to be lit.

On the ASM 475, further operating states are indicated with the LEDs PRE, ERR and SF:

Table 9- 9 Operating status display on ASM 475 via LEDs

SF	PRE_1	ERR_1	PRE_2	ERR_2	Meaning
ON	OFF/ON	ON (perm.)	OFF/ON	ON (perm.)	Hardware is defective (RAM, Flash, etc.)
ON	OFF	ON	OFF	OFF	Charger is defective (can only be repaired in the factory).
OFF	2 Hz	OFF	2 Hz	OFF	Firmware loading is active or no firmware detected <ul style="list-style-type: none"> Firmware download ASM must not be switched off
OFF	2 Hz	2 Hz	2 Hz	2 Hz	Firmware loading terminated with errors <ul style="list-style-type: none"> Restart required Load firmware again Check update files
Any	5 Hz	5 Hz	5 Hz	5 Hz	Operating system error <ul style="list-style-type: none"> Switch ASM off/on
OFF	OFF	1 flash every 2 s	OFF	1 flash every 2 s	ASM has booted and is waiting for a RESET (init_run) from the user.

9.4.6 Device connections

9.4.6.1 Wiring to the SLG

SLG D1x / SLG D1xS connection method

The following figure shows the structure of a connecting cable between the ASM and SLG. The specified colors apply to the standard MOBY cable for ASM 475.

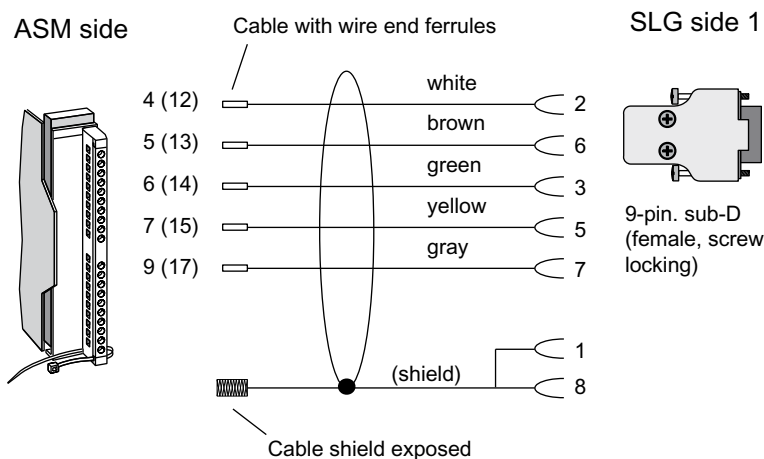

1 Caution:

When metal Sub D casings are used on the SLG side, the casing must be connected to the cable shield.

Figure 9-19 Wiring from ASM 475 to SLG D1xS with RS422 (6GT2491-0E...)

SLG D12S (plug-in version) connection method

The connecting cable has a length of 2 m (standard) and 5 m. Extensions up to 1000 m are possible with the 6GT2891-0F... plug-in cables.

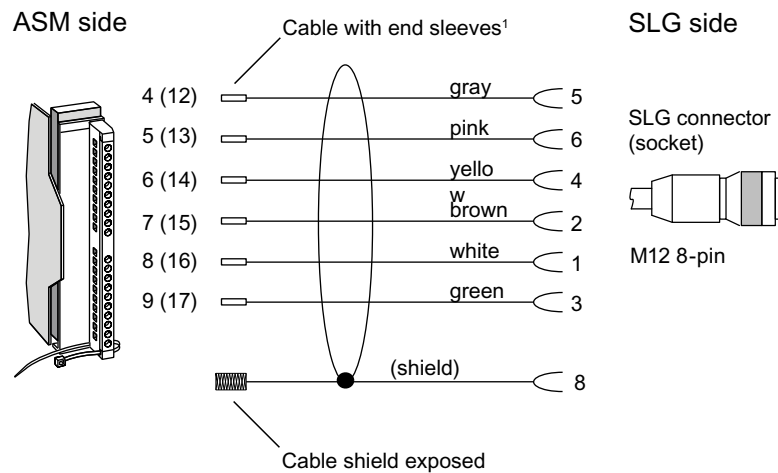

¹ 6GT2891-0E... with straight SLG connector (standard)

Figure 9-20 Connecting cable between ASM 475 and SLG D12S (plug-in version) with RS422

9.4.6.2 Shield connection

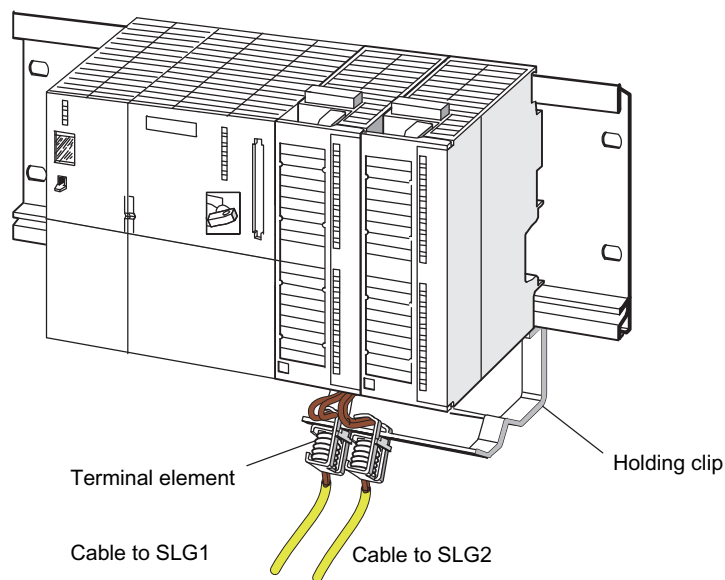

Figure 9-21 Configuration of ASM 475 with shield connecting element

9.4.6.3 Lightning protection

Implement lightning protection provided that it is appropriate for your application. An individual appraisal of the entire plant is necessary before initiating any lightning protection measures.

9.4.7 Cable

9.4.7.1 Cable assembly by the customer

To achieve electromagnetic compatibility, the SLG cable must be routed via an S7-300 shield connecting element. When the customer assembles the SLG cable, the cable shield must be exposed (see the figure below).

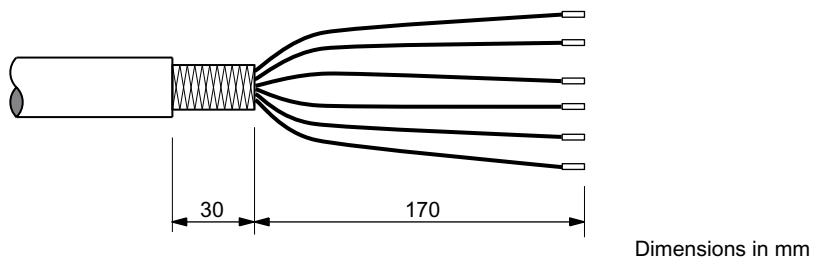

Figure 9-22 Exposure of the cable shield for cable assembly by the customer

9.4.8 Technical data

Table 9- 10 Technical specifications for ASM 475

ASM 475 with FC 45	
Serial interface for SIMATIC S7-300 or ET 200M	I/O bus; cyclic and acyclic services
Communication	2 words cyclic/238 bytes acyclic
Command buffer in ASM 475	70 x 238 bytes per SLG D1xS
Serial interface to write/read device	
Connectors	Via screw-type terminal on front connector The front connector is not included in the scope of supply.
Max. cable length	Pre-assembled cables = 5 m, 20 m, 50 m (up to 1000 m on request)
Connectable SLGs	2x SLG D1xS with RS 422 Simultaneous operation
Software functions	
Programming	Depending on the PROFIBUS DP master
Function blocks for SIMATIC S7	FC 45
MDS addressing	Direct access via addresses
Commands	Initialize MDS, read data from MDS, write data to MDS
Multitag mode	no
S7 data structures via UDTs	Yes
Power supply ¹	
<ul style="list-style-type: none"> • Rated value • Permitted range 	<ul style="list-style-type: none"> • 24 V DC • 20.4 V to 28.8 V DC
Current consumption	
<ul style="list-style-type: none"> • Without SLG for U = 24 V DC, max. • With SLG connected, max. 	<ul style="list-style-type: none"> • 350 mA • 500 mA, per connected SLG
Power dissipation of the module, typ.	2 W
Current consumption from I/O bus, max.	80 mA
Electrical isolation between S7-300 and MOBY	Yes
V24 fuse to SLG	Yes, electronic
Ambient temperature	
<ul style="list-style-type: none"> • During operation <ul style="list-style-type: none"> Horizontal installation of SIMATIC Vertical installation of SIMATIC • Transport and storage 	<ul style="list-style-type: none"> • 0 to +60 °C • 0 to +40 °C • -40 °C to +70 °C
Dimensions (W x H x D) in mm	40 x 125 x 120
Weight	approx. 0.2 kg
Degree of protection	IP20
1) With MOBY D, the SLG power supply cannot be connected through the ASM.	

9.4.9 Ordering data

Table 9- 11 Ordering data for ASM 475

	Order No.
ASM 475 interface module for SIMATIC S7 2 x SLG D1xS with RS 422 can be connected in parallel, without front connector	6GT2002-0GA10
Accessories:	
Front connector (1 x per ASM)	6ES7392-1AJ00-0AA0
SLG cable ASM 475 ↔ SLG D1xS; without SLG D12S (plug-in version)	
Lengths:	
• 5 m	6GT2491-0EH50
• 20 m	6GT2491-0EN20
• 50 m	6GT2491-0EN50
SLG cable ASM 475 ↔ SLG D12S (plug-in version)	
Opt. Cable connector without SLG cable (for cable lengths > 50 m) ASM 475 ↔ SLG	6GT2090-0BC00
Terminal element (1 x for each SLG cable)	6ES7390-5BA00-0AA0
Shield connecting element	6ES7390-5AA00-0AA0
CD <i>RFID Systems Software & Documentation</i> with FC 45, S7 object manager	6GT2080-2AA10
FC 45 Reference Manual German English French	Available in electronic form on the CD <i>RFID Systems Software & Documentation</i>

9.5 RF170C

Configured with RF170C

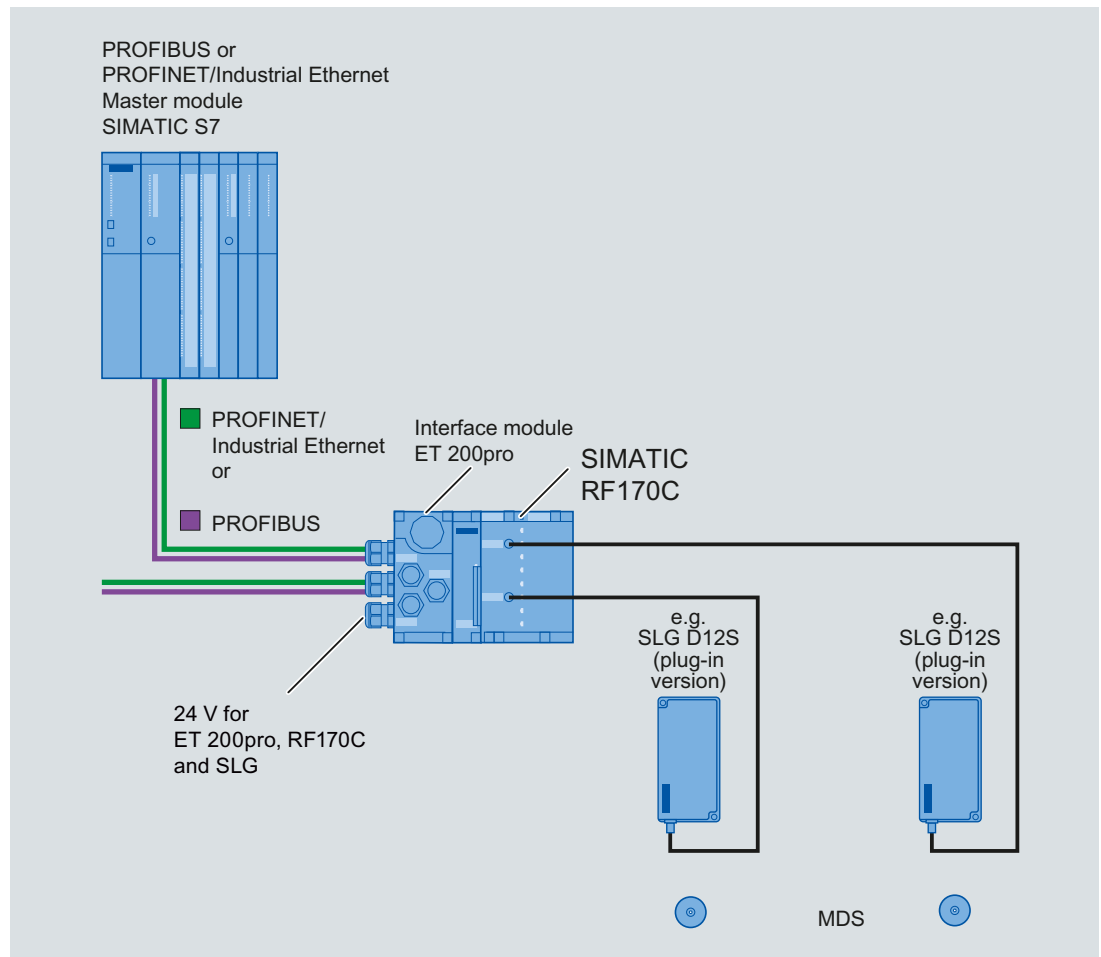

Figure 9-23 Configuration of RF170C

For more detailed information, refer to SIMATIC RF170C Operating Instructions (<http://support.automation.siemens.com/WW/view/en/32622825>).

9.6 RF180C

Configured with RF180C

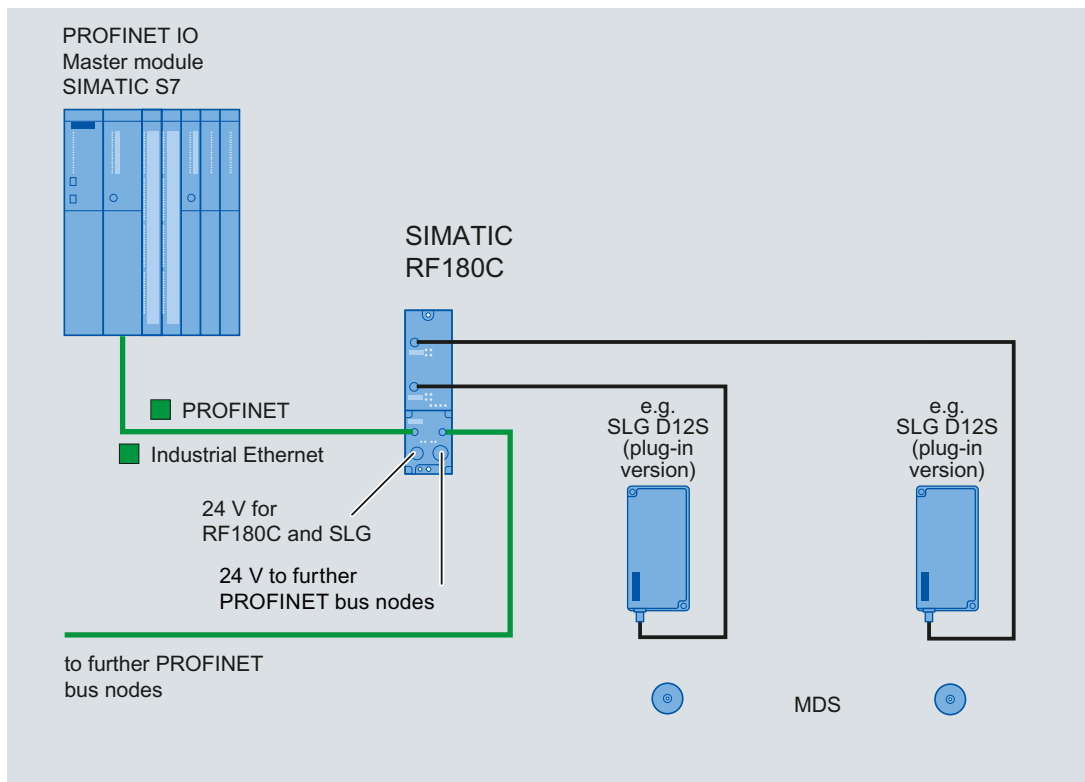

Figure 9-24 Configuration of RF180C

For more detailed information, refer to SIMATIC RF180C Operating Instructions (<http://support.automation.siemens.com/WW/view/en/30012157>).

9.7 RF182C

Configuration with RF182C

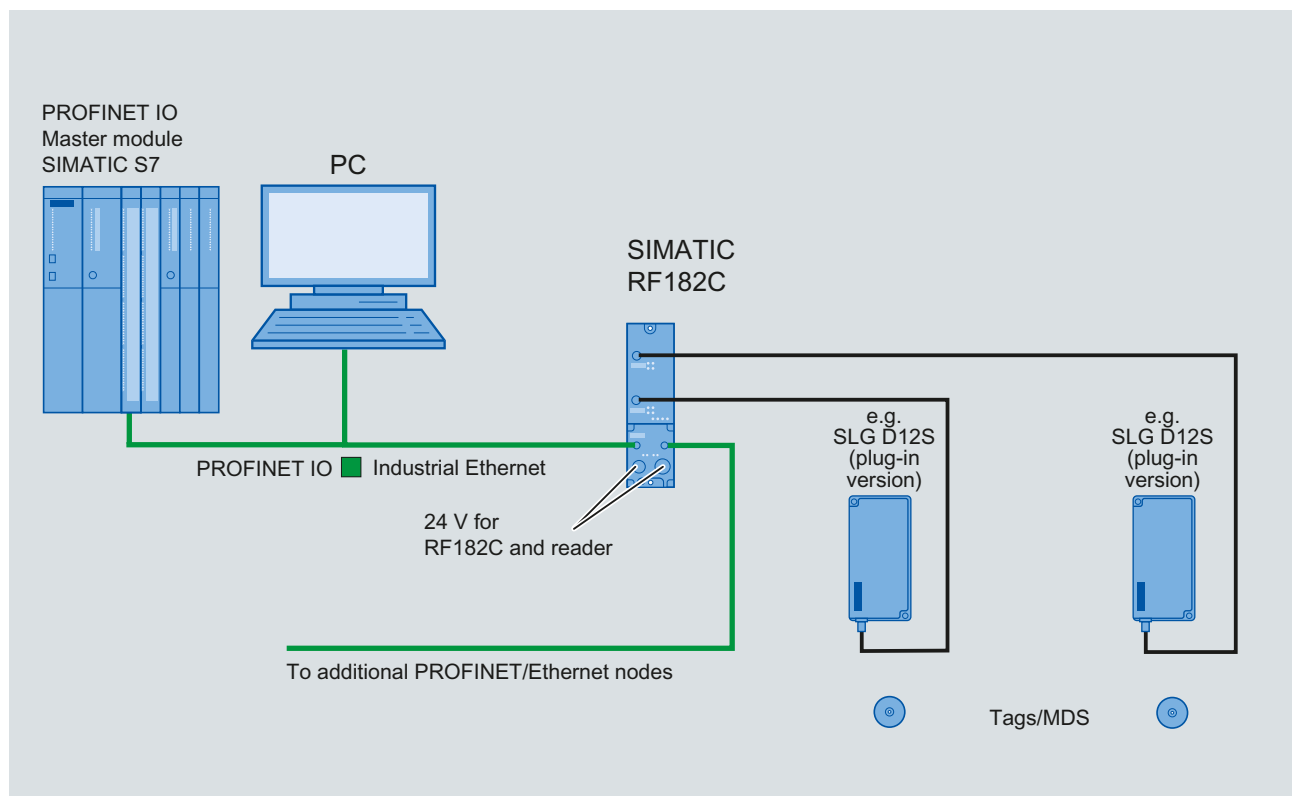



Figure 9-25 Configuration with RF182C

For more detailed information, refer to SIMATIC RF182C Operating Instructions (<http://support.automation.siemens.com/WW/view/en/38507897>).

Accessories

10.1 Wide-range power supply unit for SIMATIC RF systems

10.1.1 Features

Wide-range power supply unit for SIMATIC RF systems	
	<p>(1) DC output 1 (2) DC output 2 (3) Mains connection</p>
Features	
<ul style="list-style-type: none"> • Wide-range input (3) for use worldwide • Dimensions without mains cable: 175 x 85 x 35 mm • Dimensions including mains cable: 250 x 85 x 35 mm • CE-compliant (EU and UK versions) • UL-certified for US and Canada (US version) • Mechanically and electrically rugged design • Secondary side (1), (2): 24 V DC / 3 A • Short-circuit and no-load stability • Suitable for frame mounting • 3 versions for use in the EU, UK, US 	

10.1 Wide-range power supply unit for SIMATIC RF systems

Description

The wide-range power supply unit for SIMATIC RF systems is a universal compact power supply and provides the user with an efficient, cost-saving solution for many different mid-range power supply tasks.

The primary switched power supply is designed for use on single-phase AC systems. The two DC outputs (sockets) are connected in parallel and protected by a built-in current limiting circuit against overload and short-circuits.

The device is vacuum-cast and prepared for Safety Class 2 applications. The EU and UK versions satisfy the low-voltage guideline as well as the current EU standards for CE conformity. Furthermore, the US version has been UL-certified for the US and Canada.

10.1.2 Scope of supply

- Wide-range power supply unit for SIMATIC RF systems
- 2 m mains cable (country-specific)
- Protective cover for flange outlet
- Operating Instructions

10.1.3 Ordering data

Wide-range power supply unit for SIMATIC RF-systems (100 - 240 V AC / 24 V DC / 3 A) with 2 m connecting cable with country-specific plug	EU: 6GT2898-0AA00 UK: 6GT2898-0AA10 US: 6GT2898-0AA20
24 V-connecting cable, length 5 m	6GT2491-1HH50

10.1.4 Safety Information

 WARNING
Danger to life It is not permitted to open the device or to modify the device. The following must also be taken into account: <ul style="list-style-type: none">• Failure to observe this requirement shall constitute a revocation of the CE approval, UL certification for the US and Canada as well as the manufacturer's warranty.• For installation of the power supply, compliance with the DIN/VDE requirements or the country-specific regulations is essential.• The field of application of the power supply is limited to "Information technology in electrical office equipment" within the scope of validity of the EN 60950/VDE 0805 standard.• When the equipment is installed, it must be ensured that the mains socket outlet is freely accessible.• The housing can reach a temperature of +25 °C during operation without any adverse consequences. It must, however, be ensured that the power supply is covered in the case of a housing temperature of more than +25°C to protect persons from contact with the hot housing. Adequate ventilation of the power supply must be maintained under these conditions.

NOTICE
The wide-range power supply unit must only be used for SIMATIC products in the specifically described operating range and for the documented intended use.

If the wide-range power supply unit for SIMATIC RF systems (MLFB: 6GT2 898-0AA20) is used for an end product other than the SIMATIC RF600 system, the following must be taken into account:

- The electric strength test of the end product is to be based upon a maximum working voltage of: Transition from primary to SELV: 353 V DC, 620 Vpk
- The following secondary output circuits are SELV (low voltage; SELV = Safety Extra Low Voltage): all
- The following secondary output circuits are at non-hazardous energy levels: all
- The power supply terminals and/or connectors are suitable for field wiring if terminals are provided.

10.1 Wide-range power supply unit for SIMATIC RF systems

- The maximum investigated branch circuit rating is: 20 A
- The investigated pollution degree is: 2

 **WARNING**

If the wide-range power supply unit for SIMATIC RF systems (MLFB: 6GT2 898-0AA20) is connected to and in use for other products than the SIMATIC RF660R Portal Reader (MLFB: 6GT2811-0AA01), the end user is responsible and liable for any operation of the system or end product, which includes the wide-range power supply unit for SIMATIC RF systems (MLFB: 6GT2 898-0AA20).

 **WARNING**

Alterations to the SIMATIC RF600 components and devices as well as the use of SIMATIC RF600 components with third-party RFID devices are not permitted.

Failure to observe this requirement shall constitute a revocation of the radio equipment approvals, CE approval and manufacturer's warranty. Furthermore, the compliance to any salient safety specifications of VDE/DIN, IEC, EN, UL and CSA will not be guaranteed.

Safety notes for the US and Canada

The SIMATIC RF660R Portal Reader (MLFB: 6GT2811-0AA01) is for use only with the wide-range power supply unit for SIMATIC RF systems (MLFB: 6GT2 898-0AA20) - as optional component – or with power supplies which are UL-listed according to the safety standards specified below:

- UL 60950-1 - Information Technology Equipment Safety - Part 1: General Requirements
- CSA C22.2 No. 60950 -1 - Safety of Information Technology Equipment.

 **WARNING**

The compliance of the SIMATIC RF600 system to the safety standards mentioned above will not be guaranteed if neither the wide-range power supply unit for SIMATIC RF systems (MLFB: 6GT2 898-0AA20) nor power supplies listed according to the safety standards above are used.

10.1.5 Connecting

- There are three different (country-specific) mains cables for the EU, UK and US. The appropriate mains cable must be connected to the primary input of the power supply.

NOTICE

It is only permissible to insert or remove the mains cable when the power supply is de-energized.

- The wide-range power supply unit has total insulation (Safety Class 2), IP65
- It can be mounted using four fixing holes.

10.1.6 Technical specifications

Table 10- 1 General technical specifications

Insulation stability (prim./sec.) $U_{ins p/s}$		3.3 kV _{AC}
Insulation resistance R_{ins}		>1 G Ω
Leakage current I_{leak}	$U_{in} = 230 V_{AC}, f = 50 \text{ Hz}$	< 200 μA
Safety class (SELV)	Designed for installation in devices of Safety Class 2	
Mains buffering t_h	$U_{in} = 230 V_{AC}$	$\geq 50 \text{ ms}$
Ambient temperature		-25 °C to +55 °C
Surface temperature	Module top, center	Max. 96 °C
Storage temperature		-40 °C to +85 °C
Self-heating on full-load		max. 45 K
Interference immunity ESD HF fields Burst Surge HF injection Mains quality test	EN 61000-4-2, 4-3 up to 4-6, 4-11	Air discharge: 15 kV 10 V/m symmetrical: 2 Symmetrical: 1 10 V _{rms}
Cooler		Free convection
Dimensions L x W x H		175 mm x 85 mm x 35 mm
Weight		720 g
Housing / casting		UL 94-V0
Power supply class	according to CSA	Level 3
Degree of protection	IP 65	

10.1 Wide-range power supply unit for SIMATIC RF systems

Table 10- 2 Technical specifications for the input

Rated input voltage U_{in}	EN 60950 / UL 60950	100 to 240 V AC 120 to 353 V DC
Input voltage range U_{in}		94 to 264 V AC 120 to 375 V DC (UL: 353 V _{DC})
Input frequency f_{in}		50/60 Hz
Radio interference level		EN 55011/B
Switching frequency f_{sw}		approx. 70 kHz typ.
Length of cable		2 m

Table 10- 3 Technical specifications of the output

Output voltage tolerance ΔU_{out}	$U_{in} = 230 V_{AC}$	$U_{out nom} \leq +2 \%/ -1 \%$
Overvoltage protection		$U_{out nom} +20 \%$ typ.
Noise ΔU_{LF}	$U_{in} = \text{min.}$, BW: 1 MHz	$\leq 1 \%$ U_{out}
Noise ΔU_{HF}	$U_{in} = \text{min.}$, BW: 20 MHz	$\leq 2 \%$ U_{out}
Line Regulation Load Regulation	$U_{in} = \text{min./max.}$ $I_{out} = 10...90...10 \%$	$\leq 1,0 \%$ $\leq 1,0 \%$
Short-circuit current I_{max}	$I_{nom} = 4 A (+50^\circ C)$	105 up to 130 % I_{nom}
Settling time t_R load variations	$I_{out} = 10...90...10 \%$	< 5 ms
Temperature coefficient ϵ	$T_A = -25^\circ C$ to $+70^\circ C$	0.01 %/K
Overload behavior P_{over}		Constant current
Short-circuit protection/ No-load response		Continuous/no-load stability
Derating	$T_A > +50^\circ C$ to $+70^\circ C$	max. 2 %/K
Connector type	Flanged connector Binder, Order No.: 09-3431-90-04	4 pins

Table 10- 4 Output configurations

Input	Outputs $U1 = U2$	ILoad = $I1 + I2$	Efficiency (%)	Remarks
110 V AC	24 V DC	0 A		No-load stability
110 V AC	24 V DC	3 A	≥ 88	
220 V AC	24 V DC	0 A		No-load stability
220 V AC	24 V DC	3 A	≥ 90	

Table 10- 5 Compliance with standards

Designation	Standard	Values
Electrical safety	EN 60950 / UL 60950 / CAN/CSA 22.2 950, 3 Edition	
Conducted interference	EN 61000-6-3 EN 55011	Class B
Emission	EN 61000-6-3 EN 55011	Class B

All values are measured at full-load and at an ambient temperature of 25 °C (unless specified otherwise).

10.1.7 Pin assignment of DC outputs and mains connection

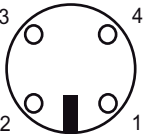
DC outputs	Assignment
	(1) Ground (0V)
	(2) +24 V DC
	(3) +24 V DC
	(4) Ground (0V)

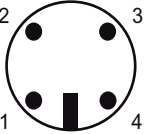
Mains connection	Assignment
	(1) 100 to 240 V AC
	(2) n.c.
	(3) 100 to 240 V AC
	(4) n.c.

10.1.8 Dimension drawing

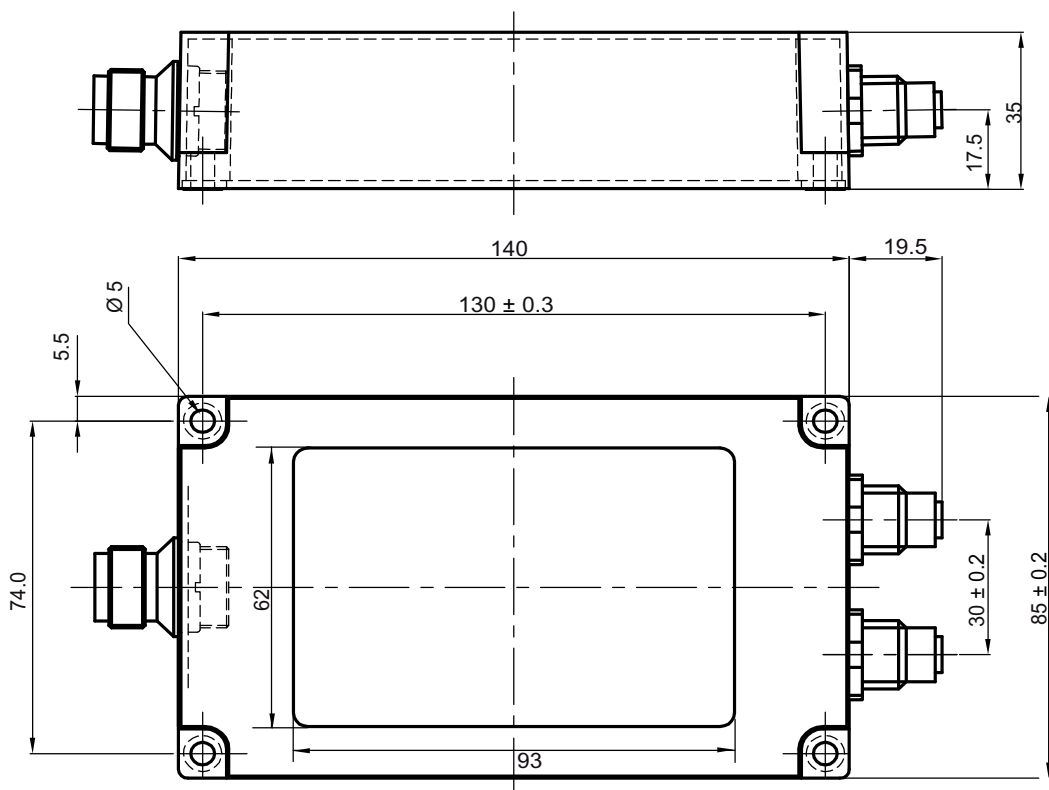

Units of measurement:
All dimensions in mm

10.1.9 Certificates and approvals

Table 10- 6 Wide-range power supply unit for SIMATIC RF systems 6GT2898-0AA00 - Europe, 6GT2898-0AA10 - UK



Certificate	Description
	CE approval to 2004/108/EC EMC 73/23/EEC LVD

Table 10- 7 Wide-range power supply unit for SIMATIC RF systems 6GT2898-0AA20 - USA

Standard	
	This product is UL-certified for the US and Canada. It meets the following safety standards: UL 60950-1 - Information Technology Equipment Safety - Part 1: General Requirements CSA C22.2 No. 60950 -1 - Safety of Information Technology Equipment UL Report E 205089

10.2 Mobile handheld terminals

SIMATIC RF310M mobile handheld terminal

Suitable for all ISO versions of MDS D1xx, MDS D2xx, MDS D 3xx, MDS D4xx.

(Does not apply for MDS D139/MDS D160 with MLFBs 6GT2600-0AA00/6GT2600-0AB00).

For detailed information on the device, see SIMATIC RF310M Operating Instructions (<http://support.automation.siemens.com/WW/view/en/26009421>).

MOBY STG Handheld Terminal PRO

Suitable for all MDS D1xx, MDS D2xx, MDS D3xx (not MDS D4XX).. No programming library available.

For more detailed information on the device, see MOBY STG Handheld Terminal PRO Operating Instructions (<http://support.automation.siemens.com/WW/view/en/26116402/0/en>).

10.3 MOBY antenna distributor

Application area

The MOBY antenna distributor is a power distributor with electrical isolation between the input (IN) and the two outputs (OUT1, OUT2). At the operating frequency of 13.56 MHz, the impedance at all inputs and outputs is 50 Ohm.

The device is used to connect 2, 3 or 4 MOBY D antennas to one SLG D10/D10S write/read device. Gate, C and tunnel arrangements are therefore possible (see configuration possibilities).



Figure 10-1 MOBY antenna distributor

Ordering data

Table 10- 8 Ordering data for MOBY antenna distributor

	Order No.
Antenna duplexer (1 antenna cable included in scope of supply)	6GT2690-0AC00
Accessories:	
Antenna cable, length 3.3 m	6GT2691-0CH33
Antenna cable, length 10.5 m	6GT2691-0CN10
Antenna extension, length 7.2 m	6GT2691-0DH72

Technical data

Table 10- 9 Technical data for MOBY D antenna distributor

Max. input power	10 W
Transmission frequency	13.56 MHz
Power supply	None
Enclosure dimensions (L x W x H) in mm	160 x 80 x 40 (without connector)
Color	Anthracite
Material	Plastic PA 12
Connector (inputs and outputs)	TNC connector
Mounting	2 x M5 screws
Ambient temperature	
• Operation	• -25 °C to +65 °C
• Transport and storage	• -25 °C to +75 °C
MTBF	3.0 x 10 ⁵ hours
Degree of protection according to EN 60529	IP65 (UL: for indoor use only)
Shock resistant according to EN 60721-3-7 Class 7M2	30 g
Total shock response spectrum Type II	
Vibration according to EN 60721-3-7 Class 7M2	1 g (9 to 200 Hz)/ 1.5 g (200 to 500 Hz)
Weight, approx.	400 g
Approval	CE UL

Alarm, error and system messages

In this chapter, you will find a list of the MOBY D error messages. The messages are subdivided into two groups:

- Error messages and causes for MOBY D with ASM and FC/FB 45 (direct MDS addressing)
- Error messages and causes for MOBY D in combination with the MDWAPI library

11.1 Error messages and causes for MOBY D in combination with the MDWAPI library

Table 11- 1 General errors

Error code in HEX	Cause, remedy
0x00	OK: <ul style="list-style-type: none"> Data/parameters read or saved without errors Control command executed

Table 11- 2 Transponder status

Error code in HEX	Cause, remedy
0x01	No transponder: <ul style="list-style-type: none"> No transponder within the detection field of the reader Transponder in detection field has been switched to silent Error in communication between reader and transponder. The reader can no longer detect the transponder.
0x02	Invalid data: <ul style="list-style-type: none"> CRC16 checksum error in the received data
0x03	Write error: Plausibility test of written data failed: <ul style="list-style-type: none"> Attempt to write to a read-only area Distance between transponder and read antenna too large Attempt to write during excessive ambient noise
0x04	Address error: The requested data lie beyond the logical or physical address range of the transponder: <ul style="list-style-type: none"> The addresses lie outside the maximum address range of the transponder The addresses lie outside the configured address range of the transponder
0x05	Invalid transponder type: This command is not supported by this transponder: <ul style="list-style-type: none"> Write or read attempt with a transponder A specific command is not supported by the transponder.
0x06	Read error: Plausibility test of read data failed: <ul style="list-style-type: none"> Distance between transponder and read antenna too large Attempt to read during excessive ambient noise

11.1 Error messages and causes for MOBY D in combination with the MDWAPI library

Table 11- 3 Parameter status

Error code in HEX	Cause, remedy
0x10	EEPROM error: <ul style="list-style-type: none"> EEPROM of the reader cannot be write-accessed Before the write procedure in the EEPROM, a faulty parameter checksum occurred.
0x11	Parameter outside the valid range: <ul style="list-style-type: none"> Valid parameter range exceeded.

Table 11- 4 Interface status

Error code in HEX	Cause, remedy
0x80	Unknown command: <ul style="list-style-type: none"> Selected function not supported by reader
0x81	Length error: <ul style="list-style-type: none"> Protocol is too long or too short
0x82	Command is not possible:
0x83	HF communication error: An error occurred in the communication between the transponder and reader. Possible causes: <ul style="list-style-type: none"> Algorithm for collision handling was not performed until no more collisions were detected. Reason for interruption: <ul style="list-style-type: none"> Timeout during communication with the host
0x94	Other data: <ul style="list-style-type: none"> More transponder data records have been requested than the transponder protocol is capable of transferring simultaneously.
0x95	ISO error: <ul style="list-style-type: none"> Additional error code for ISO transponder was sent with the response data

Table 11- 5 Error codes for ISO transponders

Error code in HEX	Explanation of error codes in the transponder response
0x01	Command not supported (the request code was not recognized)
0x02	Command not recognized (e.g. due to a format error)
0x03	Option not supported
0x0F	Unknown error
0x10	Specified block does not exist
0x11	Specified block is already disabled and cannot be disabled again
0x12	Specified block is disabled, its contents cannot be changed
0x13	Unsuccessful attempt to program the specified block
0x14	Unsuccessful attempt to disable the specified block
0xA0 - 0xDF	Error codes for user-specific commands
All others	Reserved for future use

11.2 Error messages and causes for MOBY D with ASM and FC/FB 45 (direct MDS addressing)

11.2.1 General errors

Automation system switches to STOP

- OB 86 not programmed and a slave has failed.
- OB 122 not programmed and a slave has failed.

The error does not occur until FC/FB 45 is called.

- The pointer Params_DB, command_DB or DAT_DB does not exist or is pointing to a non-existent address area.

11.2.2 Error messages

An error condition exists in FC/FB 45 whenever the "Error" variable is enabled on a channel. If this is the case, the exact cause of the error can be determined from variable "error_MOBY", "error_FC" or "error_BUS".

Table 11- 6 Classification of error messages

Error variable	Classification
error_MOBY	<p>This error was reported by the MOBY-ASM / write/read device. There are two main reasons for this:</p> <ul style="list-style-type: none"> • Communication between ASM and write/read device or between write/read device and MDS is faulty. • The ASM/SLG is unable to process the command. <p>Error_MOBY is indicated on the ASM on the ERR LED with an appropriate flashing pattern.</p>
error_FC	<p>This error is signaled by FC/FB 45.</p> <p>Main cause</p> <ul style="list-style-type: none"> • There is a parameter error in "Params_DB" or "command_DB".
error_BUS	<p>The transport layer of PROFIBUS DP is signaling an error. A PROFIBUS DP tracer and a PROFIBUS DP tester (BT 200; Order No. 6ES7 181-0AA00-0AA0) is an invaluable tool for accurate troubleshooting. The PROFIBUS DP system diagnostics can provide further information about the cause of the error. The error shown here is reported by the SFC 58/59 system function in the RET_VAL parameter. For a detailed description of the RET_VAL parameter, please refer to the SIMATIC S7 system manuals (see System software for S7-300/400).</p>

Note

When several errors occur with chained commands, the "error variable" always indicates the first error detected.

error_MOBY

Table 11- 7 Error messages of the MOBY ASM/SLG via the "error_MOBY" variable

Error code in HEX	Flashing of ERR LED	Cause, remedy
00	-	No error; result is OK
-	1x	See error code 0F
01	2x	<p>Presence error: MDS has moved out of the transmission window of the SLG. The MOBY command was executed only partially.</p> <p>Read command: No data are transmitted to FC/FB 45.</p> <p>Write command: The data storage unit which just left the field contains an incomplete data record.</p> <ul style="list-style-type: none"> Distance between SLG and MDS not adhered to Configuration error: The data block to be processed is too large (in dynamic mode) <p>The next command (READ, WRITE) will be automatically executed on the next MDS.</p> <p>Note: The error indication on the red LEDs on the front panel indicates error code 02 in this case.</p>
02	2x	<p>Presence error:</p> <ul style="list-style-type: none"> A mobile data storage unit has passed by an SLG without being processed by a command. <p>Note: The error indication on the red error LEDs does not distinguish between Error 01 and Error 02 (see error code 01).</p>
03	3x	<p>Error in the connection to the SLG</p> <ul style="list-style-type: none"> Supply voltage for the ASM is less than 20 V or not connected 24 V voltage has voltage dips, is not connected or is switched off Fuse on the ASM has blown. Check the wiring Cable between ASM and SLG is wired incorrectly or cable break. Hardware defect: ASM or SLG Interference coupling on SLG cable or bus cable Perform init_run after error correction.
04	4x	<p>Error in MDS's memory</p> <p>The data storage unit has never been write-accessed or has lost the contents of its memory due to battery failure.</p> <ul style="list-style-type: none"> Initialize data storage unit with the STG With the SLG: Call initialization command Check MDS battery or change MDS Data storage unit is defective
05	5x	<p>Unknown command</p> <p>Unknown command code in Byte 2 of the message frame SLG signals data length error (check message frame)</p> <ul style="list-style-type: none"> Faulty length of useful data

11.2 Error messages and causes for MOBY D with ASM and FC/FB 45 (direct MDS addressing)

Error code in HEX	Flashing of ERR LED	Cause, remedy
06	6x	Field interference on SLG The SLG is receiving interference from its environment. <ul style="list-style-type: none"> MDS has left the field during communication. Communication between SLG and MDS has been interrupted by external interference. The distance between two write/read devices is too small and does not correspond to the configuration guidelines Antenna error <ul style="list-style-type: none"> Antenna is unscrewed
0A	10x	Only during initialization: MDS is unable to perform the initialization command. <ul style="list-style-type: none"> MDS is defective.
0B	11x	Memory of MDS cannot be read correctly.
0C	12x	Memory of the MDS cannot be write-accessed. <ul style="list-style-type: none"> Memory of the MDS is defective.
0D	13x	Address error (address range overshoot) <ul style="list-style-type: none"> Specified address does not exist on MDS The command must be checked and corrected when the message frame is created The MDS is not the right type.
0F	15x	Start message This message is output by the ASM after every start. (A start occurs after connection of the operating voltage, after operating the front switch, after a rest via the X1 connector or following a bus error.) The start message remains active until the user issues a RESET command to the ASM. This enables the user to detect reconnection to the power supply (and therefore operational readiness) on the ASM. <ul style="list-style-type: none"> Execute an init_run
10	16x	NEXT command is not possible. <ul style="list-style-type: none"> SLG does not recognize NEXT command.
11	17x	Short-circuit or overloading of 24 V outputs Next command must be a RESET command. <ul style="list-style-type: none"> The affected output is turned off. All 24 V outputs are turned off when total overload occurs. A reset can only be performed by turning the power supply off and on again. Then start init_run.
12	18x	Internal ASM communication error <ul style="list-style-type: none"> Connector contact problem on the ASM (send in ASM for repairs) ASM hardware defect Electromagnetic interference Start init_run command after error correction.
13	19x	ASM/SLG does not have enough buffer to store the command intermediately.

11.2 Error messages and causes for MOBY D with ASM and FC/FB 45 (direct MDS addressing)

Error code in HEX	Flashing of ERR LED	Cause, remedy
14	20x	Internal ASM error or SLG error (watchdog) <ul style="list-style-type: none"> • Program sequence error on the ASM • Switch 24 V supply off and on again • Program sequence error on the SLG • Start init_run command after error correction.
15	21x	Wrong parameterization of the ASM/SLG <ul style="list-style-type: none"> • Check INPUT parameters in UDT 10. • RESET command is parameterized incorrectly. • After a start-up, the ASM has still not received an init_run.
16	22x	The command cannot be processed with the current bus configuration. <ul style="list-style-type: none"> • Input or output areas too small for the specified message frame length. Was the correct GSD file used? • Write or read command issued with length specification too large. Data length > 233 bytes. • Change the configuration of the bus in the master module
17	23x	Communication error between FC/FB 45 and MOBY-ASM. Handshake error <ul style="list-style-type: none"> • Params_DB (UDT 10) of this ASM station is being overwritten by other parts of the program. • Check parameters of MOBY ASM in UDT 10 • Check FC/FB 45 command which caused this error • Start init_run command after error correction.
18	24x	An error has occurred which must be acknowledged with an init_run. <ul style="list-style-type: none"> • A temporary short circuit has occurred on PROFIBUS DP. • The RESET command is faulty. • Start init_run command after error correction.
19	25x	Previous command is active or buffer overflow. The user sent a new command to the ASM/SLG even though the last command was still active. <ul style="list-style-type: none"> • Active command can only be terminated with an init_run. • Before a new command can be started the READY bit must be 1 (exception: init_run). • Two FC/FB 45 calls were parameterized with the same parameters ("ASM_address" and "ASM_channel") • Two FC/FB 45 calls are using the same Params_DB pointer • Start init_run command after error correction. • When command repetition (e.g., fixed code MDS) is used, no data are fetched from the MDS. The data buffer on the ASM has overflowed. MDS data have been lost.

11.2 Error messages and causes for MOBY D with ASM and FC/FB 45 (direct MDS addressing)

Error code in HEX	Flashing of ERR LED	Cause, remedy
1A	26x	<p>PROFIBUS DP error occurred</p> <ul style="list-style-type: none"> The PROFIBUS DP bus connection was interrupted <ul style="list-style-type: none"> Wire break on the bus Bus connector on ASM was removed briefly PROFIBUS DP master doesn't address ASM anymore. Execute an <code>init_run</code> The ASM has detected a message frame interruption on the bus. The PROFIBUS DP may have been reconfigured (e.g. with HW Config). <p>This error is only indicated when access monitoring has been enabled in the PROFIBUS DP configuration.</p>
1C	28x	<p>The antenna of the SLG is switched off/on and should be switched on/off again.</p> <p>The antenna is switched off and in this state, an MDS command should be executed. The antenna should be switched off, even though one MDS command is active.</p> <ul style="list-style-type: none"> The antenna is already switched off. The antenna is already switched on. Unknown mode in SET ANT command. The antenna cannot be switched off, because an MDS command is still active. The antenna is switched off, so the MDS command cannot be executed.
1D	29x	<p>More MDSes are in the transmission window than the SLG is capable of processing simultaneously.</p> <ul style="list-style-type: none"> Only one MDS can be processed at a time with FC/FB 45
1E	30x	<p>Error when processing the function</p> <ul style="list-style-type: none"> The data in UDT 10 are invalid; check UDT 10 and execute <code>init_run</code> ASM hardware is defective: ASM receives wrong data during <code>init_run</code>. AB byte does not comply with the useful data length.
1F	31x	<p>Running command canceled by RESET (<code>init_run</code> or <code>cancel</code>) or bus connector removed</p> <ul style="list-style-type: none"> Communication with the MDS was terminated by <code>init_run</code>. This error can only be reported on <code>init_run</code> or <code>cancel</code>

error_FC

Table 11- 8 Error variable "error_FC"

Error code (B#16#..)	Description
00	No error; default value if everything is ok.
01	Params_DB not available in SIMATIC
02	Params_DB too small <ul style="list-style-type: none"> UDT 10/11 was not used during definition Params_DB must be 300 bytes in length (for each channel) Check that Params_DB and Params_ADDR are correct
03	The DB after the "command_DB_number" pointer is not available in the SIMATIC.
04	"command_DB" in the SIMATIC too small <ul style="list-style-type: none"> UDT 20/21 was not used during command definition The last command in "command_DB" is a chained command; reset the chaining bit
05	Invalid command type. <ul style="list-style-type: none"> Check command pointer command_DB_number/command_DB_address Check the current values in command_DB <ul style="list-style-type: none"> Execute an init_run
06	Unexpected acknowledgement received. The parameters of the command and acknowledgement message frames do not match (command, length, address_MDS). <ul style="list-style-type: none"> The user changed the command_DB_number/_address pointer during command execution. The user changed the command parameters in the MOBY CMD data block (UDT 20) during command execution. Check the ASM_address and ASM_channel parameter settings. ASM_address and ASM_channel have the same parameters for different channels. The acknowledgement counter and command counter between the ASM and FC/FB are no longer synchronized <ul style="list-style-type: none"> Execute an init_run
07	The MOBY_mode or MDS_control parameter (defined in UDT 10) has an invalid value
08	A bus error has occurred which is reported by system functions SFC 58/59. More information on this error is available in the error_BUS variable. <ul style="list-style-type: none"> ASM_address or ASM_channel not available Execute an init_run
09	The ASM has failed. <ul style="list-style-type: none"> Power failure on MOBY-ASM PROFIBUS DP connector removed or PROFIBUS DP cable interrupted ASM_address or ASM_channel not available <p>This error is indicated if the ASM_failure bit was set in OB 122. OB 122 is called if FC/FB 45 can no longer access the cyclic word for MOBY-ASM.</p>

11.2 Error messages and causes for MOBY D with ASM and FC/FB 45 (direct MDS addressing)

Error code (B#16#..)	Description
0A	<p>Another init_run was started without waiting for ready during execution of the init_run command</p> <ul style="list-style-type: none"> Do <i>not</i> set init_run cyclically The same physical ASM channel is used in two (or more) UDT 10 structures. Check ASM_address and ASM_channel in <i>a</i>//UDT 10 structures.
0B	<p>init_run cannot be executed; cyclic Process image for ASM is faulty; FC/FB 45 signals timeout of process image to ASM This error can be deactivated by writing the value #00 to address DBB 58 in UDT 10. In certain error situations, FC/FB 45 will then, however, not generate an error message and "seize up".</p> <ul style="list-style-type: none"> ASM_address in UDT 10 is parameterized incorrectly. ASM_address may be for wrong module. ASM_channel setting is ≥ 16 or ≤ 0 ASM hardware/firmware is faulty. The same physical ASM channel is used in two (or more) UDT 10 structures. Check ASM_address and ASM_channel in <i>a</i>//UDT 10 structures.
0C	<p>Area length error on block move for FC/FB 45.</p> <ul style="list-style-type: none"> DAT_DB does not exist or is too small. Check DAT_DB_number and DAT_DB_address in UDT 20 Execute an init_run
0D	<p>An init_run was not completed correctly. The process image is not consistent.</p> <ul style="list-style-type: none"> Run init_run again Turn ASM off and on again. The RUN/STOP switch on the CPU was pressed rapidly several times in succession (particularly with slow PROFIBUS DP baud rates) The same physical ASM channel is used in two (or more) UDT 10 structures. Check ASM_address and ASM_channel in <i>a</i>//UDT 10 structures.

error_BUS

Table 11-9 Error variable "error_BUS"

Error code (W#16#...)	Description
800A	ASM is not ready (temporary message). <ul style="list-style-type: none"> This message is given to a user who is not using FC/FB 45 and is polling the ASMs acyclically, one after the other, very quickly.
8x7F	Internal error on parameter x. Cannot be remedied by the user.
8x22 8x23	Area length error on reading parameter. Area length error on writing parameter. This error code indicates that parameter x is partially or completely outside the operand area or the length of a bit array for an ANY parameter is not divisible by 8.
8x24 8x25	Area error on reading parameter. Area error on writing parameter. This error code indicates that parameter x is within an area not allowed for the system function.
8x26	Parameter contains a time cell number which is too high.
8x27	Parameter contains a counter cell number which is too high.
8x28 8x29	Alignment error on reading parameter. Alignment error on writing parameter. The reference to parameter x is an operand whose bit address is not equal to 0.
8x30 8x31	The parameter is located within the write-protected global DB. The parameter is located within the write-protected instance DB.
8x32 8x34 8x35	The parameter contains a DB number which is too high. The parameter contains an FC number which is too high. The parameter contains an FB number which is too high.
8x3A 8x3C 8x3E	The parameter contains a DB number which is not loaded. The parameter contains an FC number which is not loaded. The parameter contains an FB number which is not loaded.
8x42 8x43	An access error occurred while the system was attempting to read a parameter from the I/O area of the inputs. An access error occurred while the system was attempting to write a parameter to the I/O area of the outputs.
8x44 8x45	Error on nth (n > 1) read access after an error occurred. Error on nth (n > 1) write access after an error occurred.
8090	Specified logical base address is invalid: There is no assignment in the SDB1/SDB2x, or it is not a base address.
8092	A type other than BYTE has been specified in an ANY reference.
8093	The area identifier contained in the configuration (SDB1, SDB2x) of the logical address is not permitted for these SFCs. The following are permitted: <ul style="list-style-type: none"> 0 = S7-400 1 = S7-300 2, 7 = DP modules

11.2 Error messages and causes for MOBY D with ASM and FC/FB 45 (direct MDS addressing)

Error code (W#16#...)	Description
80A0	Negative acknowledgment while reading from module. FC/FB fetches acknowledgment although no acknowledgment is ready. A user who is not using the FC/FB 45 would like to fetch DS 101 (or DS 102 to 104) although no acknowledgment is available. <ul style="list-style-type: none"> Perform an init_run for new synchronization between ASM and application.
80A1	Negative acknowledgment while writing to the module. FC/FB sends command although ASM is unable to receive a command.
80A2	DP protocol error in layer 2. Could be a hardware defect.
80A3	DP protocol error in Direct-Data-Link-Mapper or User-Interface/User. Could be a hardware defect.
80B0	<ul style="list-style-type: none"> SFC not possible for module type Data record unknown to module Data record number ≥ 241 is not allowed. Data records 0 and 1 are not permitted for SFC58 "WR_REC."
80B1	The length specified in the RECORD parameter is wrong.
80B2	The configured slot is not occupied.
80B3	Actual module type is not the module type specified in SDB1.
80C0	<ul style="list-style-type: none"> RDREC: The module has record, but it doesn't have any read data. WRREC: ASM is not ready to receive new data <ul style="list-style-type: none"> Wait until the cyclic counter has been incremented
80C1	The data of the preceding write job on the module for the same data record have not yet been processed by the module.
80C2	The module is currently processing the maximum possible number of jobs for a CPU.
80C3	Required resources (memory, etc.) are currently in use. This error is not reported by the FC/FB 45. If this error occurs, the FC/FB 45 waits until the system is able to provide resources again.
80C4	Communication error <ul style="list-style-type: none"> Parity error SW ready not set Error in block length management Checksum error on CPU side Checksum error on module side
80C5	Distributed I/O not available

Troubleshooting/FAQ

What shall I do when nothing works?

1. Check the supply voltage directly on the SLG connector with a voltmeter.
2. Check the cables to the computer
 - Do the SLG and the computer have the same physical interface?
 - Is the polarity of the connecting cable (RS 232) correct?
(RxD of SLG must be connected to TxD of computer and vice-versa)
 - Is the cable shield connected correctly?

Error messages

More information on error messages can be found at MOBY D C/C++ MDWAPI Programming Manual (<http://support.automation.siemens.com/WW/view/en/12429971>).

The range of the SLG is too small

When the range of the SLG is too small, you must check

- Power supply unit/switched-mode power supply (see the Section *Planning the MOBY D system* regarding interference)
- Whether monitors or other sources of interference are nearby (see the Section *Planning the MOBY D system*)
- Whether metal is in the immediate vicinity (see the Section *Planning the MOBY D system*)
- To achieve optimal write/read distances with ANT D5, a metal plate is required at a distance of 100 mm (see the Section *Planning the MOBY D system*)

Certificates and approvals

Certificate	Description
	CE Approval to R&TTE

Notes on CE marking

The following applies to the system described in this documentation:
The CE marking on a device is indicative of the corresponding approval:

DIN ISO 9001 certificate







The quality assurance system for the entire product process (development, production, and marketing) at Siemens fulfills the requirements of ISO 9001 (corresponds to EN29001: 1987).

This has been certified by DQS (the German society for the certification of quality management systems).

EQ-Net certificate no.: 1323-01

Certificates for USA and Canada

Safety

One of the following markings on a device is indicative of the corresponding approval:	
	Underwriters Laboratories (UL) per UL 60950 (I.T.E) or per UL 508 (IND.CONT.EQ)
	Underwriters Laboratories (UL) according to Canadian standard C22.2 No. 60950 (I.T.E) or C22.2 No. 142 (IND.CONT.EQ)
	Underwriters Laboratories (UL) according to standard UL 60950, Report E11 5352 and Canadian standard C22.2 No. 60950 (I.T.E) or UL508 and C22.2 No. 142 (IND.CONT.EQ)
	UL recognition mark
	Canadian Standard Association (CSA) per Standard C22.2. No. 60950 (LR 81690) or per C22.2 No. 142 (LR 63533)
	Canadian Standard Association (CSA) per American Standard UL 60950 (LR 81690) or per UL 508 (LR 63533)

EMC

USA	
Federal Communications Commission Radio Frequency Interference Statement	This equipment has been tested and found to comply with the limits for a Class A digital device, pursuant to Part 15 of the FCC Rules. These limits are designed to provide reasonable protection against harmful interference when the equipment is operated in a commercial environment. This equipment generates, uses, and can radiate radio frequency energy and, if not installed and used in accordance with the instruction manual, may cause harmful interference to radio communications. Operation of this equipment in a residential area is likely to cause harmful interference in which case the user will be required to correct the interference at his own expense.
Shielded Cables	Shielded cables must be used with this equipment to maintain compliance with FCC regulations.
Modifications	Changes or modifications not expressly approved by the manufacturer could void the user's authority to operate the equipment.
Conditions of Operations	This device complies with Part 15 of the FCC Rules. Operation is subject to the following two conditions: (1) this device may not cause harmful interference, and (2) this device must accept any interference received, including interference that may cause undesired operation.

CANADA	
Canadian Notice	This Class A digital apparatus complies with Canadian ICES-003.

Service & Support

Contact partner

If you have any further questions on the use of our products, please contact one of our representatives at your local Siemens office.

The addresses are found on the following pages:

- On the Internet (www.siemens.com/automation/partner)
- In Catalog CA 01
- In Catalog FS 10 specially for factory automation sensors

Technical Support

You can access technical support for all IA/DT projects via the following:

- Phone: + 49 (0) 180 5050 222
(€ 0.14 /min. from the German landline network, deviating mobile communications prices are possible)
- E-mail (<mailto:support.automation@siemens.com>)
- Internet: Online support request form: (www.siemens.com/automation/support-request)

Service & support for industrial automation and drive technologies

You can find various services on the Support homepage (www.siemens.com/automation/service&support) of IA/DT on the Internet.

There you will find the following information, for example:

- Our newsletter containing up-to-date information on your products.
- Relevant documentation for your application, which you can access via the search function in "Product Support".
- A forum for global information exchange by users and specialists.
- Your local contact for IA/DT on site.
- Information about on-site service, repairs, and spare parts. Much more can be found under "Our service offer".

RFID homepage

For general information about our identification systems, visit RFID homepage (www.siemens.com/simatic-sensors/rf).

Technical documentation on the Internet

A guide to the technical documentation for the various products and systems is available on the Internet:

SIMATIC Guide manuals (www.siemens.com/simatic-tech-doku-portal)

Online catalog and ordering system

The online catalog and the online ordering system can also be found on the Industry Mall Homepage (<http://www.siemens.com/industrymall>).

Training center

We offer appropriate courses to get you started. Please contact your local training center or the central training center in

D-90327 Nuremberg.

Phone: +49 (0) 180 523 56 11

(€ 0.14 /min. from the German landline network, deviating mobile communications prices are possible)

For information about courses, see the SITRAIN homepage (www.sitrain.com).

Previous versions

C.1 Previous MDS version with different MLFB

C.1.1 Compatibility list

The mobile data storage units listed below are replaced by compatible successor products. The product name does not change, however, the successor products have a new order number as listed in the table below.

These type designations can also be found on the type plates of the components. You can use this table to find replacements especially in the case of types that are no longer available.

Transponder	Order No. of previous MDS version	Order No. of replacement type
MDS D100	6GT2600-0AD00	6GT2600-0AD10
MDS D124	6GT2600-0AC00	6GT2600-0AC10
MDS D139	6GT2600-0AA00	6GT2600-0AA10
MDS D160	6GT2600 0AB00	6GT2600 0AB10

C.1.2 MDS D124 (MLFB 6GT2600-0AC00)

Application area

The MDS D124 is a passive, maintenance-free transponder based on the ISO 15693 standard with I-Code technology. It was designed for applications in production and distribution logistics as well as product identification. This mobile data storage unit can also be used in a harsh environment under extreme environmental conditions (e.g. extreme temperatures).

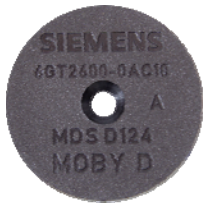

Figure C-1 MDS D124

Ordering data

Table C- 1 Ordering data for MDS D124

	Order no.
Mobile data storage unit MDS D124 Button, 112 byte EEPROM user memory	6GT2600-0AC00

Technical data

Table C- 2 Technical data for MDS D124

Memory size	128 bytes
Memory configuration	
<ul style="list-style-type: none"> • Serial number • Configuration memory • AFI/DSFID • Application memory 	<ul style="list-style-type: none"> • 8-byte (fixed code) • 6 bytes • 2 bytes • 112 bytes
Storage technology	EEPROM
Memory organization	See the Section <i>Mobile data storage units - Introduction</i>
Listing	to ISO 15693
Data contents (at +40°C)	10 years
MTBF (at +40 °C)	≥ 1.5 x 10 ⁶ hours
Data transmission rate	
<ul style="list-style-type: none"> • Read • Writing 	<ul style="list-style-type: none"> • approx. 3,5 ms/byte • approx. 9.5 ms/byte
Read cycles	Unlimited
Write cycles, typical	1 000 000
Write cycles, min.	200 000
Write/read distance (S _g)	See the Section <i>Field data</i>
Distance from metal	min. 25 mm (approx. 30 % reduction of the field data)
Multitag capability	Yes
Anti-collision speed	approx. 20 transponders/s simultaneously identifiable
Power supply	Inductive power transmission (without battery)
Degree of protection to EN 60529	IP67
Shock resistant to EN 60721-3-7, Class 7M3 total shock response spectrum, Type II	100 g
Vibration-resistant to EN 60721-3-7, Class 7M3	20 g
Torsion and bending load	Not permissible
Dimensions (D x H) in mm	27 x 4
Color	Black
Material	Epoxy casting resin
Mounting technique	Adhesive, M3 screw
Tightening torque at +20 °C	≤ 1 Nm (at high temperatures, the expansion coefficients of the materials used must be taken into account)

Previous versions

C.1 Previous MDS version with different MLFB

Ambient temperature	
• Operation	• -25 to +125°C
• Transport and storage	• -40 to +150°C
Weight, approx.	5 g

Field data

Table C-3 Field data of MDS D124

	SLG D10/D10S ANT D5	SLG D10/D10S ANT D6	SLG D10/D10S ANT D10	SLG D11/D11S ANT D5	SLG D12/ SLG D12S
Operating distance (S _a)	0 to 130 mm	0 to 130 mm	0 to 130 mm	0 to 70 mm	0 to 50 mm
Limit distance (S _g)	180 mm	180 mm	180 mm	110 mm	70 mm
Transmission window (L)	Ø 320 mm	440 mm	980 mm	Ø 300 mm	120 mm
Transmission window (W)	128 mm	340 mm	380 mm	120 mm	48 mm
Minimum distance from MDS to MDS	≥ 0.8 m	≥ 1.2 m	≥ 1.8 m	≥ 0.8 m	≥ 0.3 m

Dimensions (in mm)

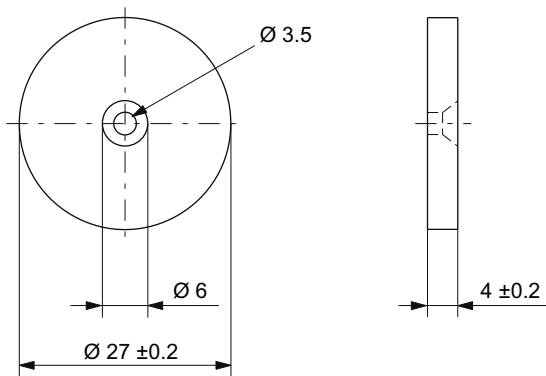

Figure C-2 Dimensions of MDS D124

Metal-free area

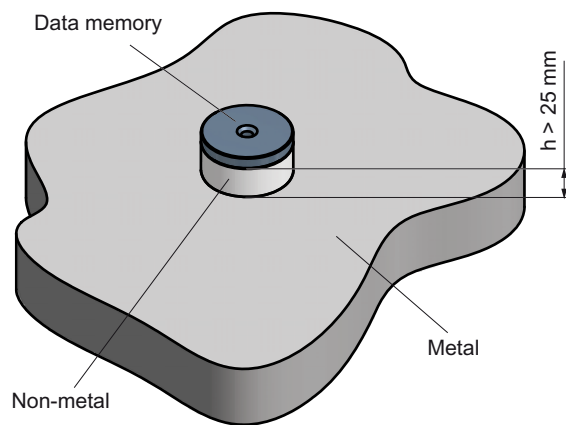

Figure C-3 Metal-free area for MDS D124

Note

If the minimum guide values (h) are not observed, a reduction of the field data results. It is possible to mount the MDS with metal screws (M3 countersunk head screws). This has no tangible impact on the range.

When installing in the vicinity of metal, observe the instructions in the Section *Planning the MOBY D system*.

C.1.3 MDS D139 (MLFB 6GT2600-0AA00)

Application area

These reusable, cyclic heat-proof transponders with a limited service life are required for use in production logistics and in assembly lines subject to high temperatures (up to +200 °C). The MDS D139 is a passive, maintenance-free transponder with 44 bytes of user memory. This data storage unit is considerably less expensive than the heat-proof mobile data storage units available today due to its simple construction (without thermal insulation), but also due to its lack of complexity.



Figure C-4 MDS D139

Ordering data

Table C- 4 Ordering data for MDS D139

	Order No.
Mobile data storage units MDS D139 Heat-proof (r/w) up to +200 °C / +220 °C with 44 bytes user memory	6GT2600-0AA00
Accessories: Spacers	6GT2690-0AA00

Technical data

Table C- 5 Technical data for MDS D139

Memory size	64 bytes
Memory configuration	
<ul style="list-style-type: none"> • Serial number • Configuration memory • Family code/application UID • Application memory 	<ul style="list-style-type: none"> • 8 bytes (fixed code) • 8 bytes • 4 bytes • 44 bytes
Storage technology	EEPROM
Memory organization	See the Section <i>Mobile data storage units - Introduction</i>
Data retention	10 years
MTBF	2×10^6 hours
Read cycles	Unlimited
Write cycles	
<ul style="list-style-type: none"> • at + 40 °C, typical • at + 70 °C, min. 	<ul style="list-style-type: none"> • 500 000 • 10 000
Write/read distance (S_g)	See <i>Field data</i>
Distance from metal	min. 30 mm (approx. 30 % reduction of the field data)
Multitag capability	Yes
Power supply	Inductive power transmission (without battery)
Degree of protection according to EN 60529	IP68
Shock resistant according to EN 60721-3-7, Class 7M3 Total shock response spectrum, Type II	50 g
Vibration-resistant according to EN 60721-3-7, Class 7M3	20 g
Torsion and bending load	Not permissible
Enclosure dimensions (D x H) in mm	85 x 15
Color	Black
Material	Plastic PPS
Mounting	1 x M5 screw ¹
Tightening torque	1.5 Nm ²

Previous versions

C.1 Previous MDS version with different MLFB

Ambient temperature		
<ul style="list-style-type: none"> • Operation 	<ul style="list-style-type: none"> • -25 °C to +100 °C • +140 °C • +200 °C³ • +220 °C 	<ul style="list-style-type: none"> • permanent • 20% reduction in the limit distance • Tested up to 4,000 hours or 1,500 cycles • Tested up to 2000 hours or 500 cycles
<ul style="list-style-type: none"> • Transport and storage 	<ul style="list-style-type: none"> • -40 °C to +100 °C 	
Weight, approx. 50 g		
<p>1) To prevent damage to the MDS at high temperature (depending on the expansion coefficients), an M5 stainless steel screw must be used to attach it to the spacer (6GT2690-0AA00).</p> <p>2) At higher temperatures (>+80 °C), the expansion coefficients of all materials must be observed</p> <p>3) At temperatures of +140 °C and above, processing is not possible</p>		

Field data

Table C- 6 Field data for MDS D139

	SLG D10/D10S ANT D5	SLG D10/D10S ANT D6	SLG D10/D10S ANT D10	SLG D11/D11S ANT D5	SLG D12/SLG D12S
Operating distance (S _a)	0 to 380 mm	0 to 480 mm	0 to 380 mm	0 to 240 mm	0 to 120 mm
Limit distance (S _g)	450 mm	550 mm	450 mm	300 mm	150 mm
Transmission window (L)	Ø 320 mm	520 mm	1000 mm	Ø 300 mm	120 mm
Transmission window (W)	128 mm	420 mm	400 mm	120 mm	48 mm
Minimum distance from MDS to MDS	≥ 1 m	≥ 1.5 m	≥ 2 m	≥ 1 m	≥ 0.5 m

ATEX

The MDS D139 mobile data memory is classed as a piece of simple, electrical equipment and can be operated in the Category 2G protection zone.

Dimensions (in mm)

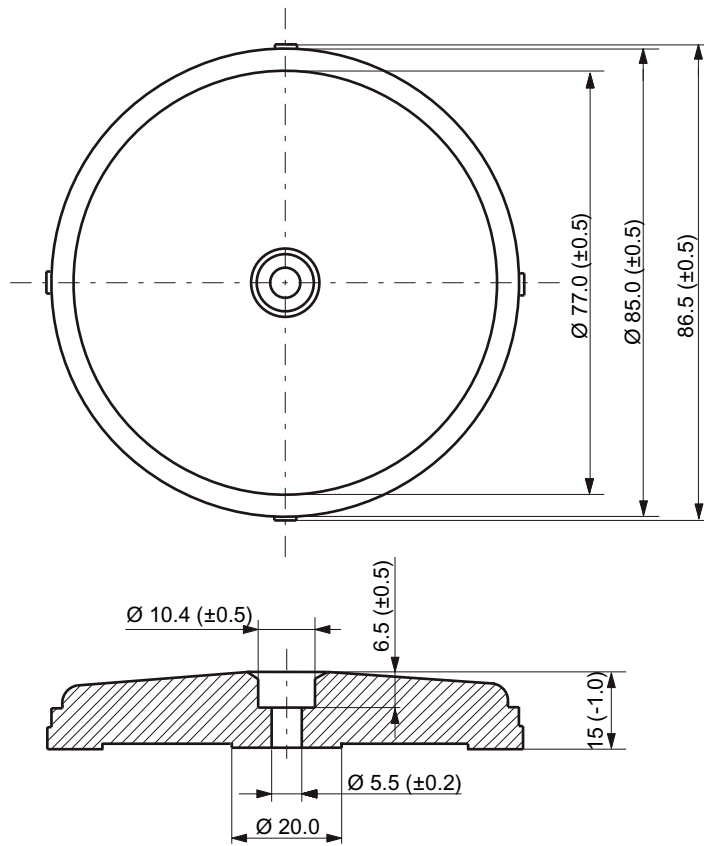
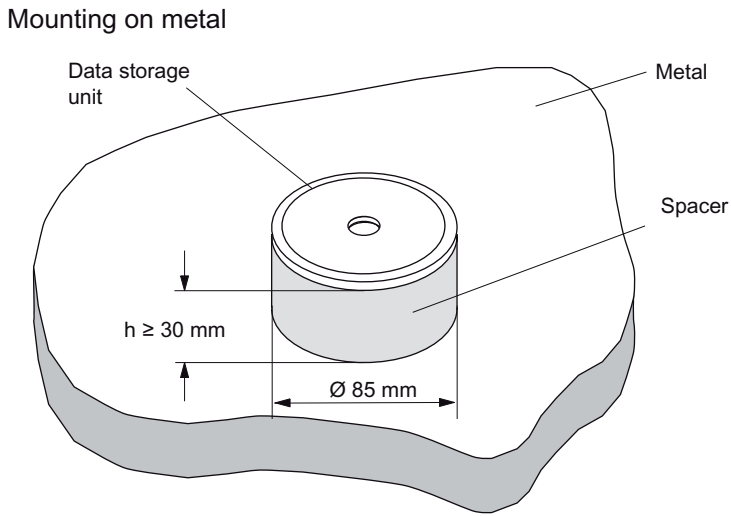

Figure C-5 Dimensions of MDS D139

Metal-free area



Flush-mounting of the MDS in metal is not permitted!

Figure C-6 Metal-free area for MDS D139

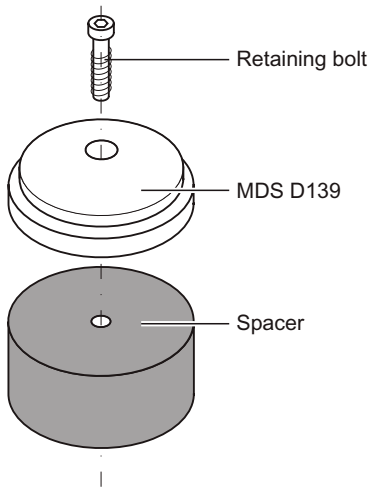

Figure C-7 MDS D139: Mounting with a spacer

Note

If the minimum guide values (h) are not observed, a reduction of the field data results. It is possible to mount the MDS with metal screws (M5). This has no tangible impact on the range. It is recommended that a test is performed in critical applications.

When installing in the vicinity of metal, observe the instructions in the Section *Planning the MOBY D system*.

C.2 Discontinued SLG with ANT D5

C.2.1 Compatibility list

The write/read devices with antennas listed below will no longer be available as package. Only the individual components can be ordered.

The write/read devices can be used compatibly as individual components and their previous properties have not changed. The product name does not change, the individual SLGs are, however, still available as basic device with the same order numbers

Write/read device with ANT D5	Order No. (discontinued)	Order No. of replacement type	
		Basic unit	Antenna ANT D5
SLG D10 ANT D5	6GT2601-0AA00	6GT2698-1AA00	6GT2698-5AA00
SLG D11 ANT D5	6GT2601-0AC00	6GT2698-1AC00	
SLG D10S ANT D5	6GT2602-0AA00	6GT2698-2AA00	
SLG D11S ANT D5	6GT2602-0AC00	6GT2698-2AC00	

C.2.2 SLG D10 ANT D5 (MLFB 6GT2601-0AA00)

Application area

SLG D10 ANT D5 is a write/read device in the high-end performance range with a serial interface and a separate antenna which has been specially designed for warehouses, logistics and distribution. It is designed for a range of up to 480 mm. The write/read device is equipped with a serial RS 232 interface (RS 422 interface on request) which supports communication with the PC or non-Siemens PLCs.

For fast and easy programming, a C library is available to the user that supports the use of Windows 9x, 2000, NT and XP. SLG D10 ANT D5 has multitag capability.



Figure C-8 Write/read device SLG D10 ANT D5

Ordering data

Table C- 7 Ordering data for SLG D10 ANT D5

Product	Order No.
Write/read device SLG D10 ANT D5 With RS 232 serial interface for standard PC, with separate antenna	6GT2601-0AA00
Accessories: Spacer kit for ANT D5 Wide-range power supply unit for SIMATIC RF systems (100 - 240 V AC / 24 V DC / 3 A) with 2 m connecting cable and country-specific plug. <ul style="list-style-type: none"> • EU • UK • US Cables and connectors	6GT2690-0AB00 <ul style="list-style-type: none"> • 6GT2898-0AA00 • 6GT2898-0AA10 • 6GT2898-0AA20 See the Section <i>Planning the MOBY D system</i>

Technical data

Table C- 8 Technical data for SLG D10 ANT D5

Inductive interface to the MDS	
Transmission frequency	13.56 MHz
Transponders supported	Transponders to ISO 15693 and I-Code1
Serial interface to the user	RS 232 (RS 422 on request)
Transmission protocol	Asynchronous 8 bit
Data transmission rate	9600 baud to 115.2 Kbaud (adjustable)
Data backup	CRC 16
Transmit power	4 W
Write/read distances SLG - MDS	480 mm typically (see field data) ¹
Software functions	Read, write, initialize MDS, access rights, multitag
Programming	Windows 9x, 2000, NT and XP with 32 bit DLL available
Multitag	Yes
Anti-collision speed	approx. 20 labels/s simultaneously identifiable
Power supply	--- DC 24 V \pm 5 %
Current consumption	
<ul style="list-style-type: none"> • Operation • Inrush current, momentary 	<ul style="list-style-type: none"> • 0.9 A • 2.8 A/50 ms
Cable length, SLG - PC	
<ul style="list-style-type: none"> • With RS 232 	<ul style="list-style-type: none"> • 30 m (depending on data transfer rate)
Antenna cable length	3.60 m (included in scope of supply)
Digital inputs/outputs	None
Dimensions (L x W x H) in mm	
<ul style="list-style-type: none"> • For antenna • For the electronics 	<ul style="list-style-type: none"> • 340 x 325 x 38 • 320 x 145 x 100 without connector
Color	
<ul style="list-style-type: none"> • Antenna • SLG housing 	<ul style="list-style-type: none"> • Black • Anthracite
Material	
<ul style="list-style-type: none"> • Antenna • SLG housing 	<ul style="list-style-type: none"> • Plastic ASA • Aluminum
Connectors	
<ul style="list-style-type: none"> • Antenna (plugs into SLG) • V24 interface • Power Supply 	<ul style="list-style-type: none"> • TNC connector • 9-pin Sub-D connector (male) • 4-pin M12 connector (male)
SLG fixing	4 x M6 screws
Antenna attachment	4 x M5 screws

Ambient temperature	
• Operation	• -20 °C to +55 °C
• Transport and storage	• -25 °C to +70 °C

MTBF	
• SLG D10	• 7,5 x 10 ⁴ hours
• ANT D5	• 3.0 x 10 ⁵ hours

Degree of protection to EN 60529	
• SLG and antenna	• IP65 (UL: For indoor use only)

Shock resistant to EN 60721-3-7, Class 7M2 Total shock response spectrum, Type II	30 g
--	------

Vibration compliant with EN 60721-3-7, Class 7M2	• 1 g (9 to 200 Hz)/ • 1.5 g (200 to 500 Hz)
--	---

Weight, approx.	
• SLG	• 3500 g
• Antenna	• 1000 g

Approvals	• CE • FCC • IC • Harmless to heart pacemakers • UL 60950
-----------	---

1) In order to guarantee optimum field data even in the vicinity of metal, ANT D5 is calibrated at the factory at a distance of 100 mm from metal.

Note

The antenna cable is permanently preassembled. Any modifications made to the cable will invalidate both the warranty and the CE approval.

FCC information

Siemens MOBY D SLG D10

FCC ID: NXW-MOBYD-SLGD10

This device complies with Part 15 of the FCC Rules. Operation is subject to the following two conditions:

- (1) This device may not cause harmful interference, and
- (2) This device must accept any interference that may cause undesired operation.

Note

The manufacturer is not responsible for any radio or TV interference caused by unauthorized changes and modifications to this equipment:
Such modifications could void the user's authority to operate the equipment.

IC information

The installer of this radio equipment must ensure that the antenna is located or pointed such that it does not emit RF field in excess of Health Canada limits for the general population; consult Safety Code 6, obtainable from Health Canada's website www.hc-sc.gc.ca/rpb. This device has been designed to operate with only the antennas as described in this manual. Use of further antennas is strictly prohibited per regulations of Industry Canada. The required antenna impedance is 50 ohms.

This Class A digital apparatus complies with Canadian ICES-003.
Cet appareil numérique de la classe A est conforme à la norme NMB-003 du Canada.

Field data

Table C-9 Field data for SLG D10 ANT D5

Limit distance (S_g)	max. 480 mm (dependent on transponder)
Operating distance (S_a)	0 to 400 mm (dependent on transponder)
Length of the transmission window (L_d)	320 mm
Width of the transmission window (W)	128 mm
Min. distance from ANT D5 to ANT D5	≥ 2 m

Transmission window

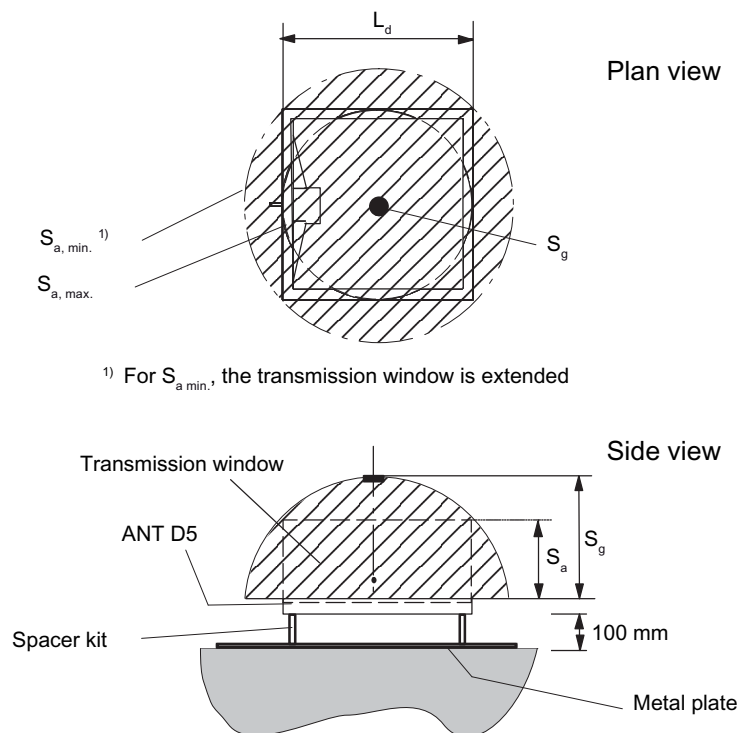

Figure C-9 Transmission window for SLG D10 ANT D5

Metal-free area

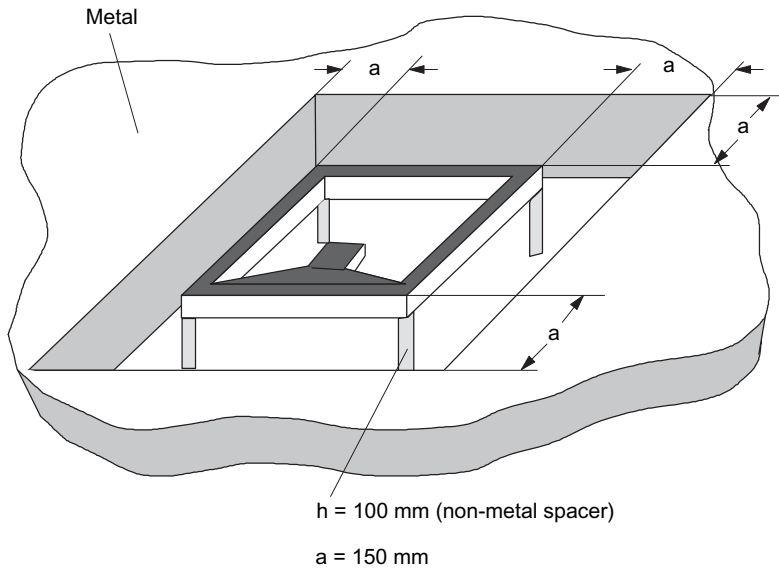

Figure C-10 Metal-free area for SLG D10 ANT D5

When installing in the vicinity of metal, observe the instructions in the Section *Planning the MOBY D system*.

Definition of distance D

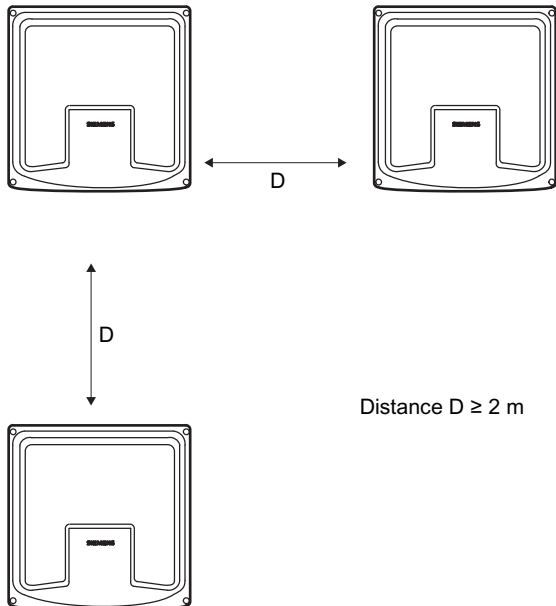
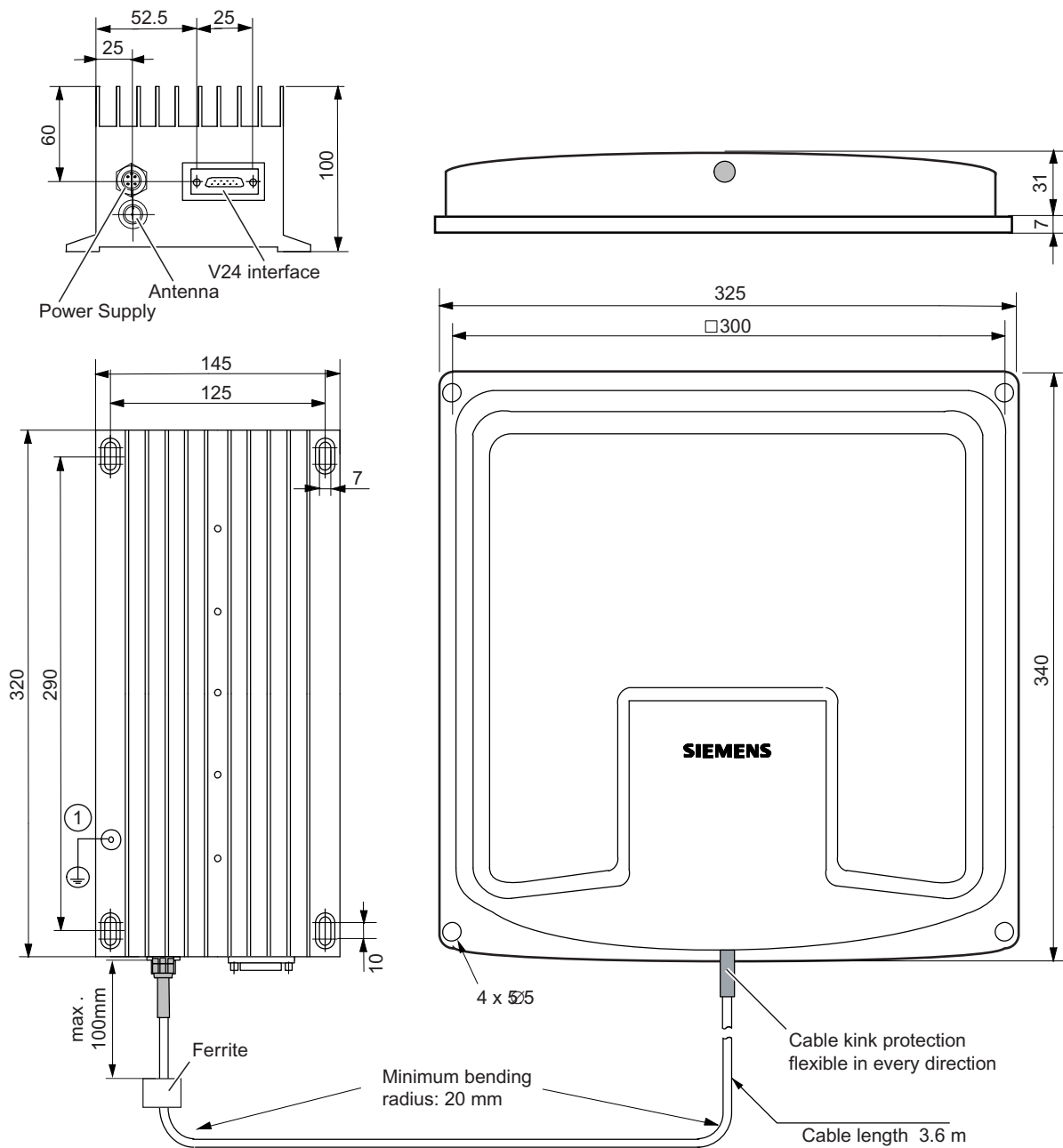

Figure C-11 Distance D: SLG D10 ANT D5

Dimensions (in mm)



Note:
 The SLG must be grounded on grounding screw (1).

Figure C-12 Dimension drawing for SLG D10 ANT D5

Note

In order to guarantee optimum field data even in the vicinity of metal, ANT D5 is calibrated at the factory at a distance of 100 mm from metal.

Spacer kit for MOBY D ANT D5

See the Section *Write/read devices, SLG D10 basic unit*

C.2.3 SLG D11 ANT D5 (MLFB 6GT2601-0AC00)

Application area

SLG D11 ANT D5 is a write/read device in the mid performance range with a serial interface and a separate antenna which has been specially designed for warehouses, logistics and distribution. It is designed for a range of up to 380 mm (depending on the label). The write/read device is equipped with a serial RS 232 interface which supports communication with the PC or non-Siemens PLCs.

For fast and easy programming, a C library is available to the user that supports the use of Windows 9x, 2000, NT and XP.

SLG D11 ANT D5 has multitag capability.



Figure C-13 Write/read device SLG D11 ANT D5

Ordering data

Table C- 10 Ordering data for SLG D11 ANT D5

	Order no.
SLG D11 ANT D5 write/read device basic unit with RS 232 serial interface for standard PC, with separate antenna	6GT2601-0AC00
Accessories: Spacer kit for ANT D5	6GT2690-0AB00
Wide-range power supply unit for SIMATIC RF systems (100 - 240 V AC / 24 V DC / 3 A) with 2 m connecting cable and country-specific plug.	
<ul style="list-style-type: none"> • EU • UK • US 	<ul style="list-style-type: none"> • 6GT2898-0AA00 • 6GT2898-0AA10 • 6GT2898-0AA20
Cables and connectors	see Chapter <i>Planning the MOBY D system</i>

Technical data

Table C- 11 Technical data for SLG D11 ANT D5

Inductive interface to the MDS	
Transmission frequency	13.56 MHz
Transponders supported	Transponders to ISO 15693 and I-Code1
Serial interface to the user	RS 232
Transmission protocol	Asynchronous 8 bit
Data transmission rate	9600 baud to 38.4 Kbaud (adjustable)
Data backup	CRC 16
Transmit power	1 W
Write/read distances SLG - MDS	380 mm typically (see field data) ¹
Software functions	Read, write, initialize MDS, access rights, multitag
Programming	Windows 9x, 2000, NT and XP, with 32 bit DLL available
Multitag	Yes
Anti-collision speed	approx. 20 labels/s simultaneously identifiable
Power supply	
• Rated value	• --- DC 24 V
• Permitted range	• --- DC 20 V ... 30 V (--- DC 24 V ± 5 % UL only)
Current consumption	
• Operation	• 150 mA
• Inrush current, momentary	• 600 mA
Cable length, SLG - PC	
• With RS 232	• 30 m
Antenna cable length	3.60 m
Digital inputs/outputs	None
Dimensions (L x W x H) in mm	
• For antenna	• 340 x 325 x 38
• For the electronics	• 160 x 80 x 40 without connector
Color	
• Antenna	• Black
• SLG housing	• Anthracite
Material	
• Antenna	• Plastic ASA
• SLG housing	• Plastic PA 12
Connectors	
• Antenna (plugs into SLG)	• TNC connector
• V24 interface	• 9-pin Sub-D connector (male)
• Power Supply	• 4-pin M12 connector (male)
SLG fixing	2 x M5 screws

Antenna attachment	4 x M5 screws
Ambient temperature	
• Operation	• -25 °C to +55 °C
• Transport and storage	• -25 °C to +70 °C
MTBF	
• SLG D11	• 2.0 x 10 ⁵ hours
• ANT D5	• 3.0 x 10 ⁵ hours
Degree of protection to EN 60529	
• SLG and antenna	IP65 (UL: for indoor only)
Shock resistant to EN 60721-3-7 Class 7M2 Total shock response spectrum, Type II	30 g
Vibration compliant with EN 60721-3-7, Class 7M2	1 g (9 to 200 Hz)/1.5 g (200 to 500 Hz)
Weight, approx.	
• SLG	• 600 g
• Antenna	• 1000 g
Approvals	<ul style="list-style-type: none"> • CE • FCC • IC • Harmless to heart pacemakers • UL 60950

1) In order to guarantee optimum field data even in the vicinity of metal, ANT D5 is calibrated at the factory at a distance of 100 mm from metal.

CAUTION

The antenna cable is permanently preassembled. Any modifications made to the cable will invalidate both the warranty and the CE approval.

Note

The SLG D11 can process up to 4 MDSes with I-Code 1-Chip (e.g. MDS D139) in multitag mode!

FCC information

Siemens MOBY D SLG D11

FCC ID: NXW-MOBYD-SLGD11

This device complies with Part 15 of the FCC Rules. Operation is subject to the following two conditions:

- (1) This device may not cause harmful interference, and
- (2) This device must accept any interference that may cause undesired operation.

Note

The manufacturer is not responsible for any radio or TV interference caused by unauthorized changes and modifications to this equipment:

Such modifications could void the user's authority to operate the equipment.

IC information

The installer of this radio equipment must ensure that the antenna is located or pointed such that it does not emit RF field in excess of Health Canada limits for the general population; consult Safety Code 6, obtainable from Health Canada's website www.hc-sc.gc.ca/rpb. This device has been designed to operate with only the antennas as described in this manual. Use of further antennas is strictly prohibited per regulations of Industry Canada. The required antenna impedance is 50 ohms.

This Class A digital apparatus complies with Canadian ICES-003.

Cet appareil numérique de la classe A est conforme à la norme NMB-003 du Canada.

Field data

Table C- 12 Field data for SLG D11 ANT D5

Limit distance (S_g)	max. 380 mm (dependent on transponder)
Operating distance (S_a)	0 to 300 mm (dependent on transponder)
Length of the transmission window (L_d)	300 mm
Width of the transmission window (W)	120 mm
Min. distance from ANT D5 to ANT D5	≥ 2 m

Transmission window

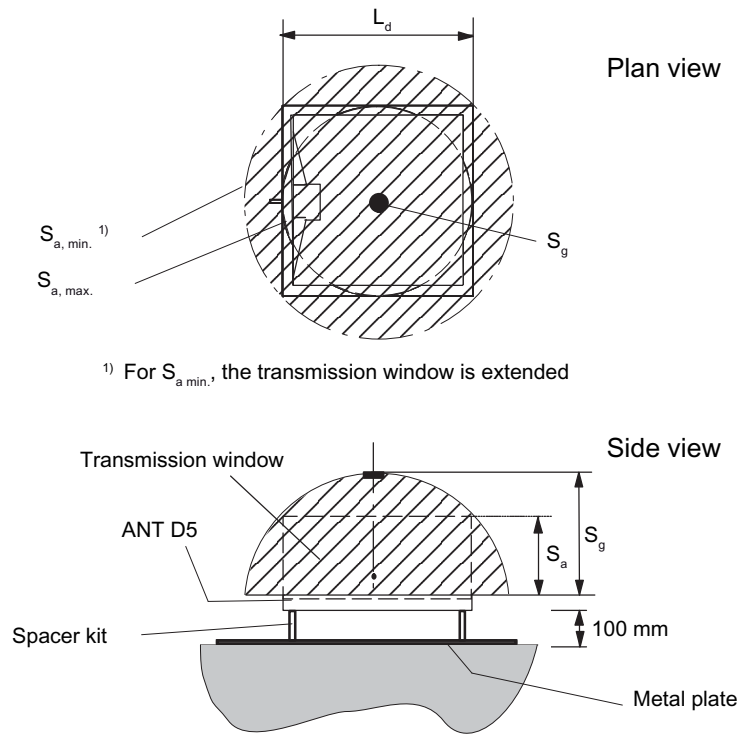

Figure C-14 Transmission window for SLG D11 ANT D5

Metal-free area

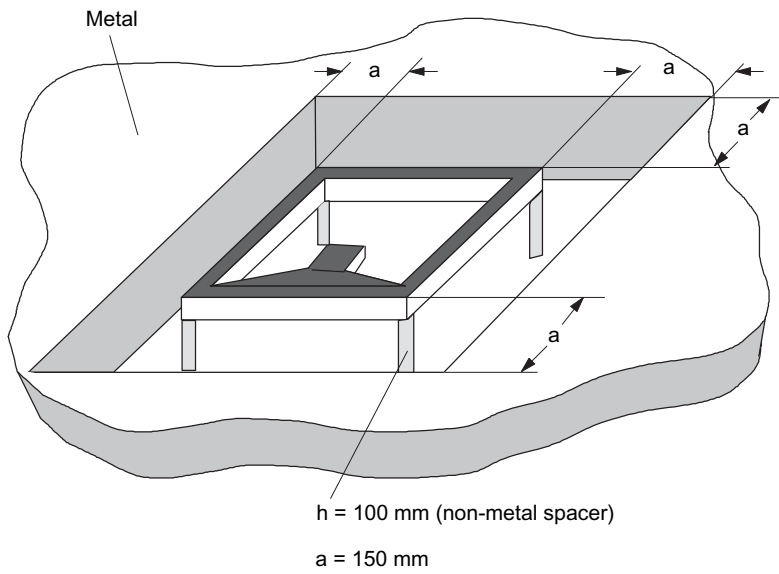

Figure C-15 Metal-free area for SLG D11 ANT D5

When installing in the vicinity of metal, observe the instructions in the Section *Planning the MOBY D system*.

Definition of distance D

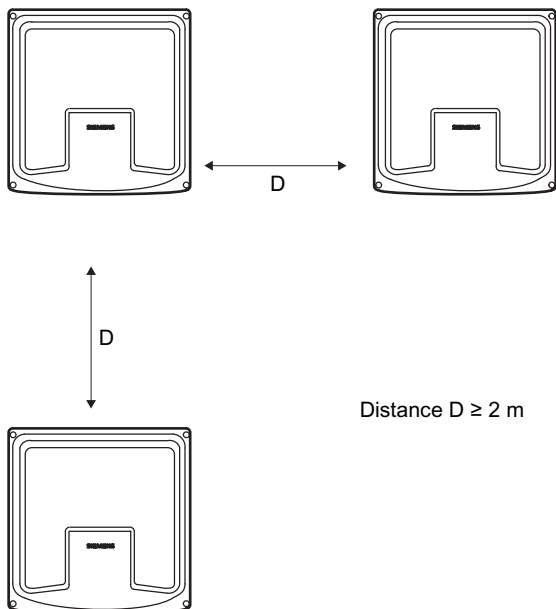

Figure C-16 Distance D: SLG D11 ANT D5

Dimensions (in mm)

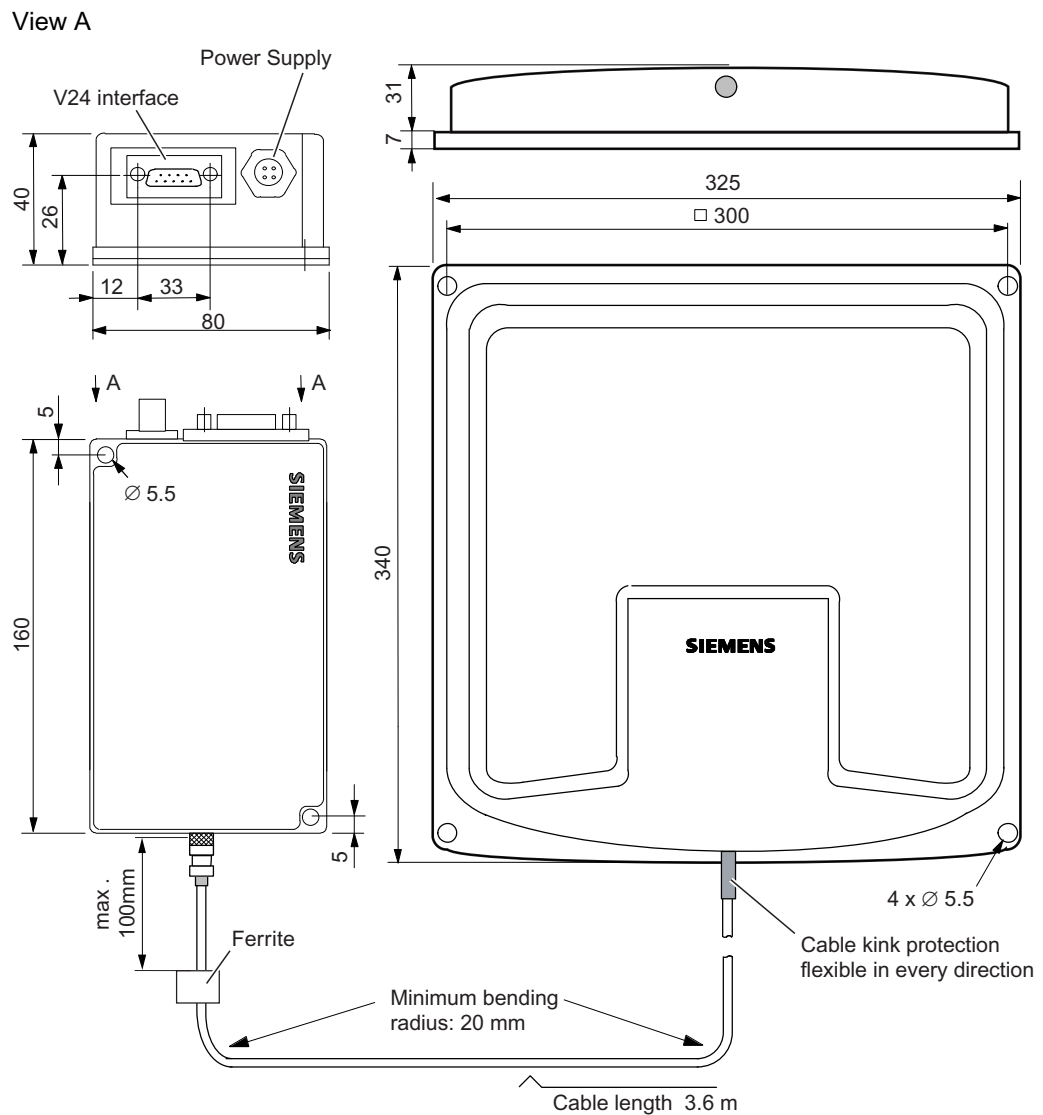

Figure C-17 Dimension drawing for SLG D11 ANT D5

Note

In order to guarantee optimum field data even in the vicinity of metal, ANT D5 is calibrated at the factory at a distance of 100 mm from metal.

Spacer kit for MOBY D ANT D5

See the Section *Write/read devices, SLG D10 basic unit*

C.2.4 SLG D10S ANT D5 (6GT2602-0AA00)

Application area

SLG D10S ANT D5 is a write/read device in the high-end performance range with a serial interface and a separate antenna which has been specially designed for warehouses, logistics and distribution. It is designed for a range of up to 480 mm. The write/read device is equipped with a serial RS 422 interface that supports communication to SIMATIC S7 or PROFIBUS DP-V1 through the interface modules (ASM 452, ASM 456, ASM 473 and ASM 475).

FC 45 is one method of quick and easy programming available to the user. With the high degree of protection (IP65) and the use of high-quality materials, the SLG D10S ANT D5 ensures problem-free operation under the harshest industrial conditions.



Figure C-18 Write/read device SLG D10S ANT D5

Ordering data

Table C- 13 Ordering data for SLG D10S ANT D5

	Order No.
Write/read device SLG D10S ANT D5 With a serial RS 422 interface for connection to ASM 452, ASM 456, ASM 473 and ASM 475, with a remote antenna	6GT2602-0AA00
Accessories: Spacer kit for ANT D5 Wide-range power supply unit for SIMATIC RF systems (100 - 240 V AC / 24 V DC / 3 A) with 2 m connecting cable and country-specific plug. <ul style="list-style-type: none"> • EU • UK • US • 24 V connecting cable, 5 m in length Cables and connectors	6GT2690-0AB00 <ul style="list-style-type: none"> • 6GT2898-0AA00 • 6GT2898-0AA10 • 6GT2898-0AA20 • 6GT2491-1HH50 See the Section <i>Planning the MOBY D system</i>

Technical data

Table C- 14 Technical data for SLG D10S ANT D5

Inductive interface to the MDS	
Transmission frequency	13.56 MHz
Transponders supported	Transponders according to ISO 15693 and I-Code1
Serial interface to the user	
Transmission protocol	RS 422
Data transmission rate	19.2 Kbaud to 115.2 Kbaud (depending on ASM)
Data backup	CRC 16
Transmit power	4 W
Write/read distances for SLG	450 mm typically (see field data) ¹
Software functions	Read, write, initialize MDS The Repeat command is not permissible. A buffer of up to 256 bytes is available in the SLG for concatenating commands For one command, therefore, it is only possible to combine commands until the sum of the header and user data of the individual message frames does not exceed this value. FC 45 limits the user data length for each individual message frame to 233 bytes.
Programming	FC 45
Transmission protocol	3964R
Multitag	Available soon
Power supply	--- DC 24 V \pm 5 %
Current consumption	
<ul style="list-style-type: none"> • Operation • Inrush current, momentary 	<ul style="list-style-type: none"> • 0.9 A • 2.8 A/50 ms
Cable length for SLG S7	
<ul style="list-style-type: none"> • With RS 422 	<ul style="list-style-type: none"> • 300 m
Antenna cable length	3.60 m (included in scope of supply)
Digital inputs/outputs	None
Enclosure dimensions (L x W x H) in mm	
<ul style="list-style-type: none"> • For antenna • For the electronics 	<ul style="list-style-type: none"> • 340 x 325 x 38 • 320 x 145 x 100 (without connector)
Color	
<ul style="list-style-type: none"> • Antenna • SLG housing 	<ul style="list-style-type: none"> • Black • Anthracite
Material	
<ul style="list-style-type: none"> • Antenna • SLG housing 	<ul style="list-style-type: none"> • Plastic ASA • Aluminum

Connector	<ul style="list-style-type: none"> • Antenna (plugs into SLG) • RS 422 interface • Power supply 	<ul style="list-style-type: none"> • TNC connector • 9-pin Sub-D connector (male) • 4-pin M12 connector (male)
SLG fixing	4 x M6 screws	
Antenna attachment	4 x M5 screws	
Ambient temperature	<ul style="list-style-type: none"> • Operation • Transport and storage 	<ul style="list-style-type: none"> • -20 °C to +55 °C • -25 °C to +70 °C
MTBF	<ul style="list-style-type: none"> • SLG D10S • ANT D5 	<ul style="list-style-type: none"> • 7.5×10^4 hours • 3.0×10^5 hours
Degree of protection according to EN 60529	<ul style="list-style-type: none"> • SLG and antenna 	<ul style="list-style-type: none"> • IP65 (UL: for indoor use only)
Shock resistant according to EN 60721-3-7 Class 7M2 Total shock response spectrum Type II	30 g	
Vibration according to EN 60721-3-7 Class 7M2	1 g (9 to 200 Hz)/ 1.5 g (200 to 500 Hz)	
Weight, approx.	<ul style="list-style-type: none"> • SLG • Antenna 	<ul style="list-style-type: none"> • 3500 g • 1000 g
Approvals	<ul style="list-style-type: none"> • CE • FCC • IC • Harmless to heart pacemakers • UL 60950 	

¹⁾ In order to ensure optimum field data even in the vicinity of metal, ANT D5 is calibrated at the factory at a distance of 100 mm from metal.

CAUTION

The antenna cable is permanently preassembled. Any modifications made to the cable will invalidate both the warranty and the CE approval.

Note

After detaching the ANT D5 antenna from the SLG and connecting it again (by screwing), an `init_run` must always be performed.

FCC information

Siemens MOBY D SLG D10S

FCC ID: NXW-MOBYD-SLGD10

This device complies with Part 15 of the FCC Rules. Operation is subject to the following two conditions:

- (1) This device may not cause harmful interference, and
- (2) This device must accept any interference that may cause undesired operation.

Note

The manufacturer is not responsible for any radio or TV interference caused by unauthorized changes and modifications to this equipment:

Such modifications could void the user's authority to operate the equipment.

IC information

The installer of this radio equipment must ensure that the antenna is located or pointed such that it does not emit RF field in excess of Health Canada limits for the general population; consult Safety Code 6, obtainable from Health Canada's website www.hc-sc.gc.ca/rpb. This device has been designed to operate with only the antennas as described in this manual. Use of further antennas is strictly prohibited per regulations of Industry Canada. The required antenna impedance is 50 ohms.

This Class A digital apparatus complies with Canadian ICES-003.

Cet appareil numérique de la classe A est conforme à la norme NMB-003 du Canada.

Field data

Table C- 15 Field data for SLG D10S ANT D5

Limit distance (S_g)	max. 480 mm (dependent on transponder)
Operating distance (S_a)	0 to 400 mm (dependent on transponder)
Length of the transmission window (L_d)	320 mm
Width of transmission window (W)	128 mm
Min. distance from ANT D5 to ANT D5	≥ 2 m

Transmission window

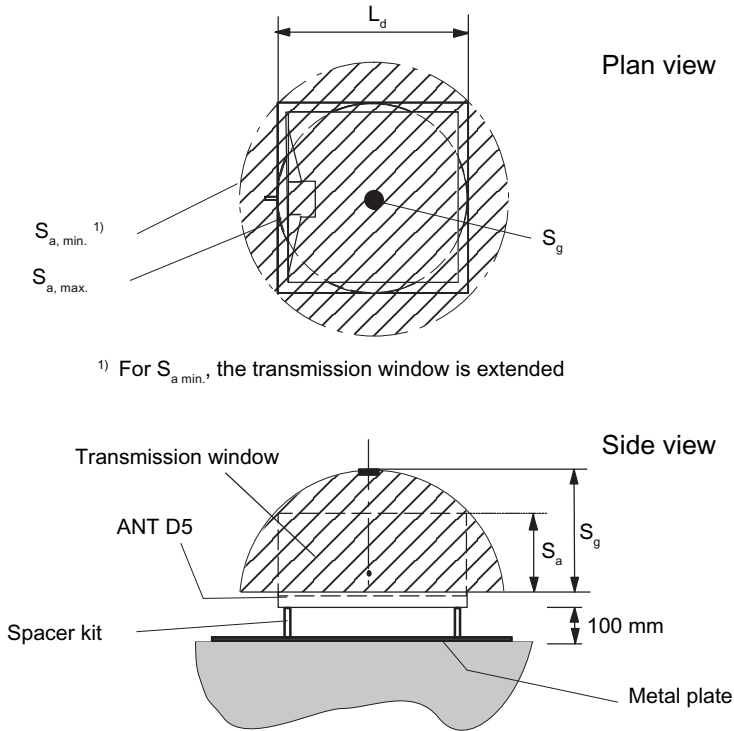

¹⁾ For $S_{a, min.}$, the transmission window is extended

Figure C-19 Transmission window for SLG D10S ANT D5

Metal-free area

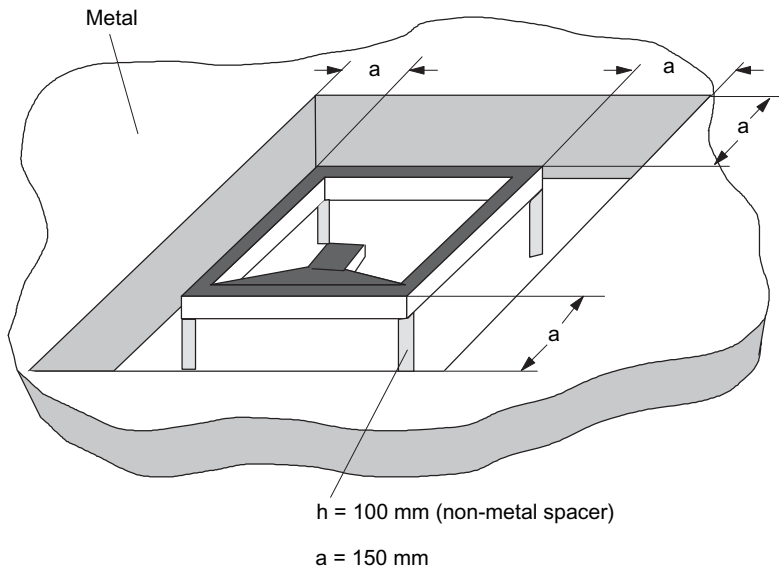

Figure C-20 Metal-free area for SLG D10S ANT D5

When installing in the vicinity of metal, observe the instructions in the Section *Planning the MOBY D system*.

Definition of distance D

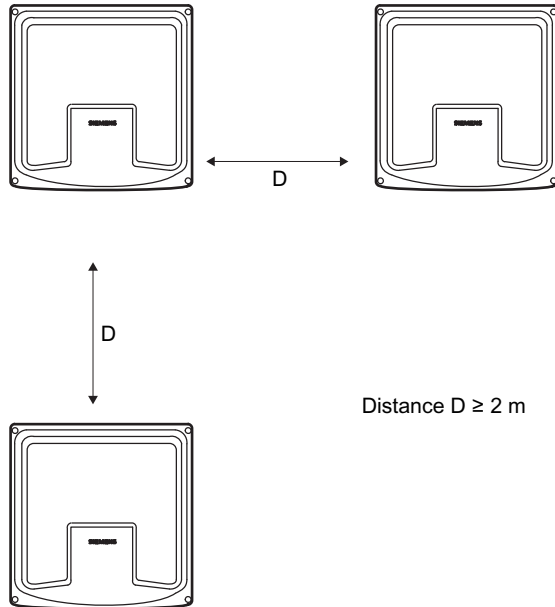
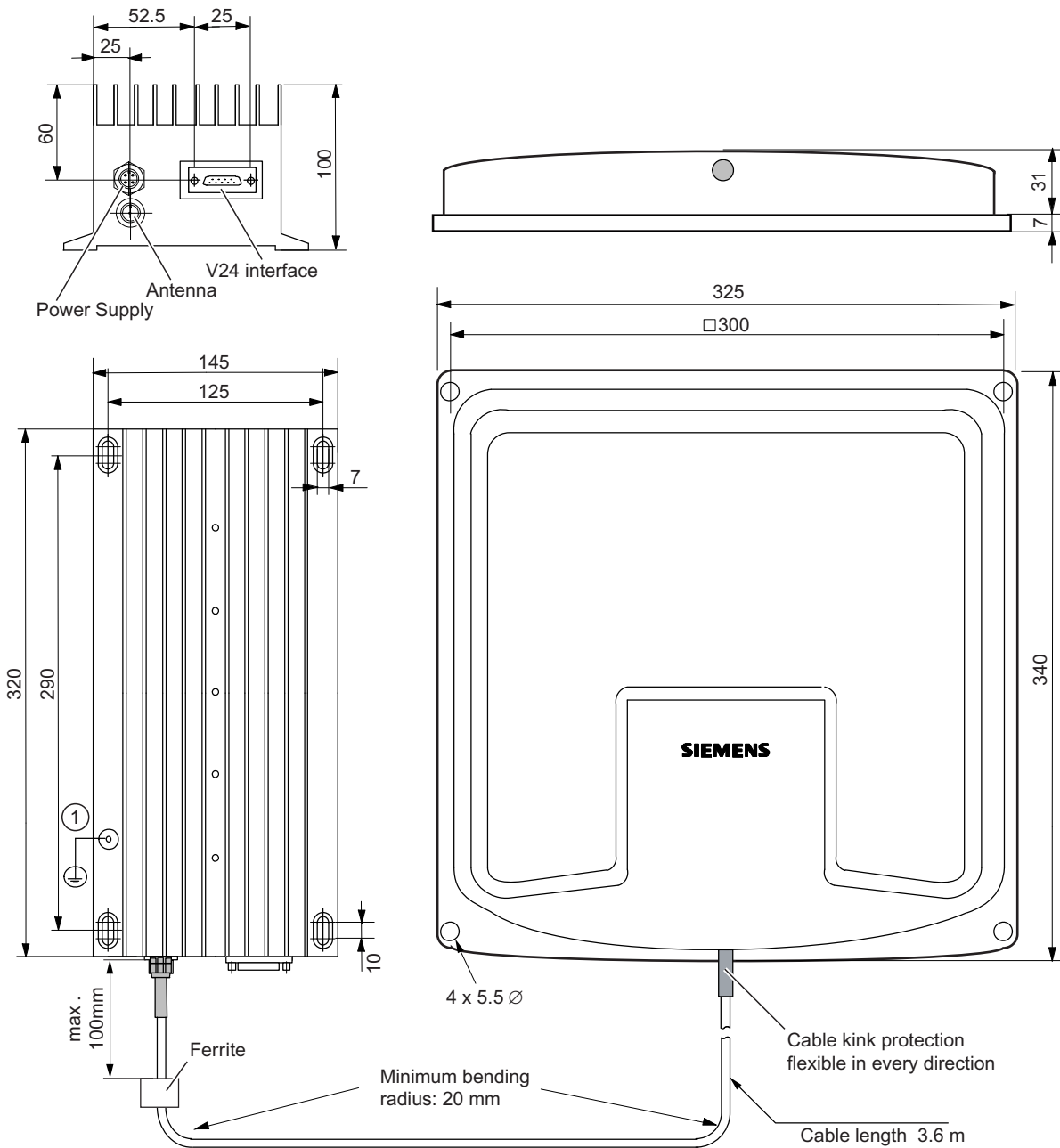

Figure C-21 Distance D: SLG D10S ANT D5

Dimensions (in mm)



Note:
The SLG must be grounded on grounding screw (1).

Figure C-22 Dimension drawing for SLG D10S ANT D5

Note

In order to guarantee optimum field data even in the vicinity of metal, ANT D5 is calibrated at the factory at a distance of 100 mm from metal.

Spacer kit for MOBY D ANT D5

See the Section *Write/read devices, SLG D10 basic unit*

C.2.5 SLG D11S ANT D5 (6GT2602-0AC00)

Application area

SLG D11S ANT D5 is a write/read device in the mid performance range with a serial interface and a separate antenna which has been specially designed for warehouses, logistics and distribution. It is designed for a range of up to 380 mm (depending on the label). The write/read device is equipped with a serial RS 422 interface that supports communication to SIMATIC S7 or PROFIBUS DP-V1 through the interface modules (ASM 452, ASM 456, ASM 473 and ASM 475).

FC 45 is one method of quick and easy programming available to the user. The rugged housing and high degree of protection (IP65) permit use even under the toughest industrial conditions.



Figure C-23 Write/read device SLG D11S ANT D5

Ordering data

Table C- 16 Ordering data for SLG D11S ANT D5

	Order
Write/read device SLG D11S ANT D5 With a serial RS 422 interface for connection to ASM 452, ASM 456, ASM 473 and ASM 475, with a remote antenna	6GT2602-0AC00
Accessories: Spacer kit for ANT D5 Wide-range power supply unit for SIMATIC RF systems (100 - 240 V AC / 24 V DC / 3 A) with 2 m connecting cable and country-specific plug. <ul style="list-style-type: none"> • EU • UK • US • 24 V connecting cable, 5 m in length Cables and connectors	6GT2690-0AB00 <ul style="list-style-type: none"> • 6GT2898-0AA00 • 6GT2898-0AA10 • 6GT2898-0AA20 • 6GT 491-1HH50 See the Section <i>Planning the MOBY D system</i>

Technical data

Table C- 17 Technical data for SLG D11S ANT D5

Inductive interface to the MDS	
Transmission frequency	13.56 MHz
Transponders supported	Transponders to ISO 15693 and I-Code1
Serial interface to the user	RS 422
Transmission protocol	Asynchronous 8 bit
Data transmission rate	19.2 Kbaud
Data backup	CRC 16
Transmit power	1 W (reset parameter 04 hex)
Write/read distances SLG - MDS	380 mm typically (see field data) ¹
Software functions	Read, write and initialize MDS Concatenated commands are not permitted. The Repeat command is not implemented. The largest possible useful data length in a command is 233 bytes.
Programming	FC 45
Transmission protocol	3964R
Multitag	no
Power supply	
• Operation	• --- DC 24 V
• Permitted range	• --- DC 20 V ... 30 V (--- DC 24 V ± 5 % UL only)
Current consumption	
• Operation	• 150 mA
• Inrush current, momentary	• 600 mA
Cable length SLG – SIMATIC S7	
• With RS 422	• 300 m
Antenna cable length	3.60 m (included in scope of supply)
Digital inputs/outputs	None
Dimensions (L x W x H) in mm	
• For antenna	• 340 x 325 x 38
• For the electronics	• 160 x 80 x 40 without connector
Color	
• Antenna	• Black
• SLG housing	• Anthracite
Material	
• Antenna	• Plastic ASA
• SLG housing	• Plastic PA 12
Connectors	
• Antenna (plugs into SLG)	• TNC connector
• RS-422 interface	• 9-pin Sub-D connector (male)
• Power Supply	• 4-pin M12 connector (male)

Previous versions

C.2 Discontinued SLG with ANT D5

SLG fixing	2 x M5 screws
Antenna attachment	4 x M5 screws
Ambient temperature	
• Operation	• -25 to +55°C
• Transport and storage	• -25 to +70°C
MTBF	
• SLG D11S	• 2.0 x 10 ⁵ hours
• ANT D5	• 3.0 x 10 ⁵ hours
Degree of protection to EN 60529	
• SLG and antenna	• IP65 (UL: For indoor use only)
Shock resistant to EN 60721-3-7, Class 7M2	30 g
Total shock response spectrum, Type II	
Vibration compliant with EN 60721-3-7, Class 7M2	1 g (9 to 200 Hz)/ 1.5 g (200 to 500 Hz)
Weight, approx.	
• SLG	• 600 g
• Antenna	• 1000 g
Approvals	
	• CE
	• FCC
	• IC
	• Harmless to heart pacemakers
	• UL 60950
1) In order to guarantee optimum field data even in the vicinity of metal, ANT D5 is calibrated at the factory at a distance of 100 mm from metal.	

FCC information

Siemens MOBY D SLG D11S

FCC ID: NXW-MOBYD-SLGD11

This device complies with Part 15 of the FCC Rules. Operation is subject to the following two conditions:

- (1) This device may not cause harmful interference, and
- (2) This device must accept any interference that may cause undesired operation.

Note

The manufacturer is not responsible for any radio or TV interference caused by unauthorized changes and modifications to this equipment:

Such modifications could void the user's authority to operate the equipment.

IC information

The installer of this radio equipment must ensure that the antenna is located or pointed such that it does not emit RF field in excess of Health Canada limits for the general population; consult Safety Code 6, obtainable from Health Canada's website www.hc-sc.gc.ca/rpb. This device has been designed to operate with only the antennas as described in this manual. Use of further antennas is strictly prohibited per regulations of Industry Canada. The required antenna impedance is 50 ohms.

This Class A digital apparatus complies with Canadian ICES-003.
Cet appareil numérique de la classe A est conforme à la norme NMB-003 du Canada.

Field data

Table C- 18 Field data for SLG D11S ANT D5

Limit distance (S_g)	max. 380 mm (dependent on transponder)
Operating distance (S_a)	0 to 300 mm (dependent on transponder)
Length of the transmission window (L_d)	300 mm
Width of the transmission window (W)	120 mm
Min. distance from ANT D5 to ANT D5	≥ 2 m

Transmission window

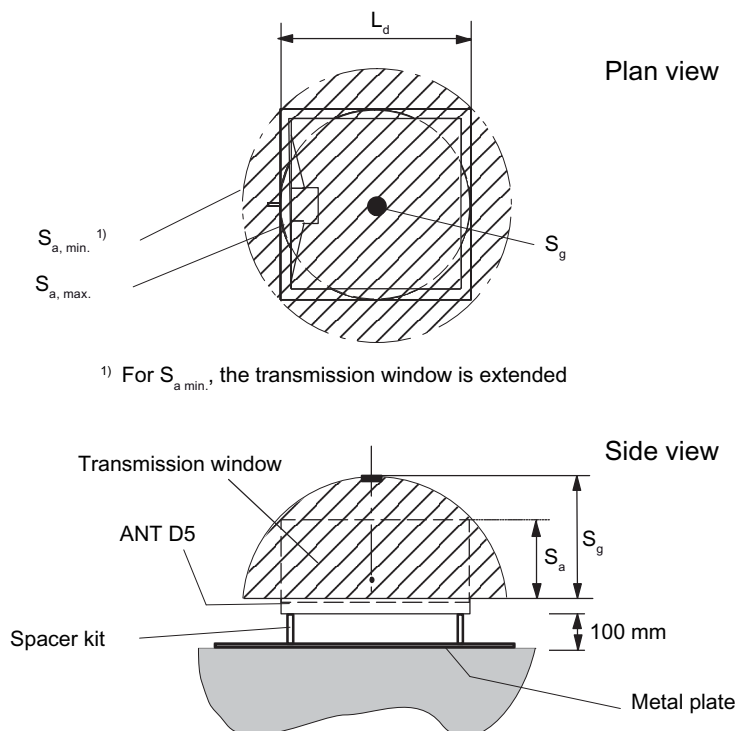

Figure C-24 Transmission window for SLG D11S ANT D5

Metal-free area

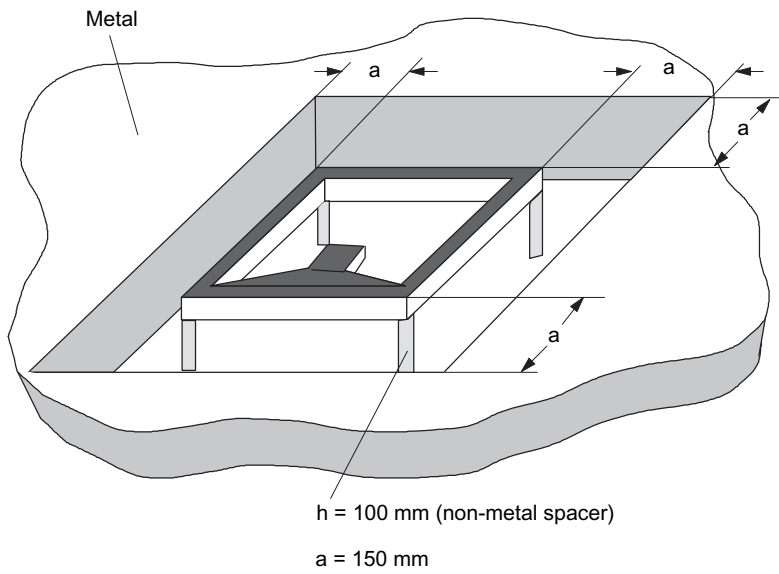

Figure C-25 Metal-free area for SLG D11S ANT D5

When installing in the vicinity of metal, observe the instructions in the Section *Planning the MOBY D system*.

Definition of distance D

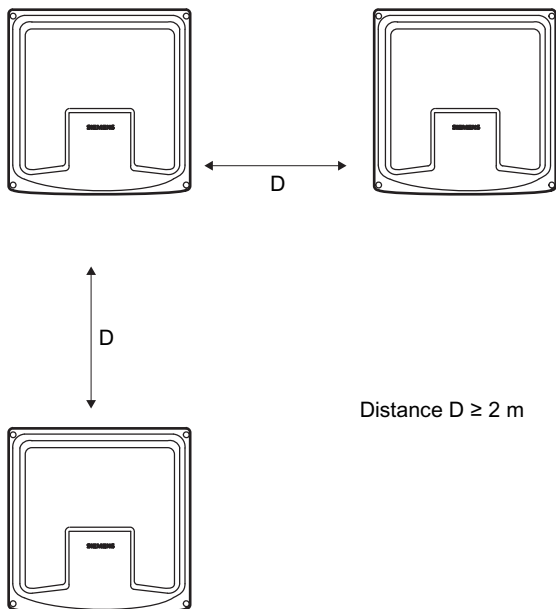

Figure C-26 Distance D: SLG D11S ANT D5

Dimensions (in mm)

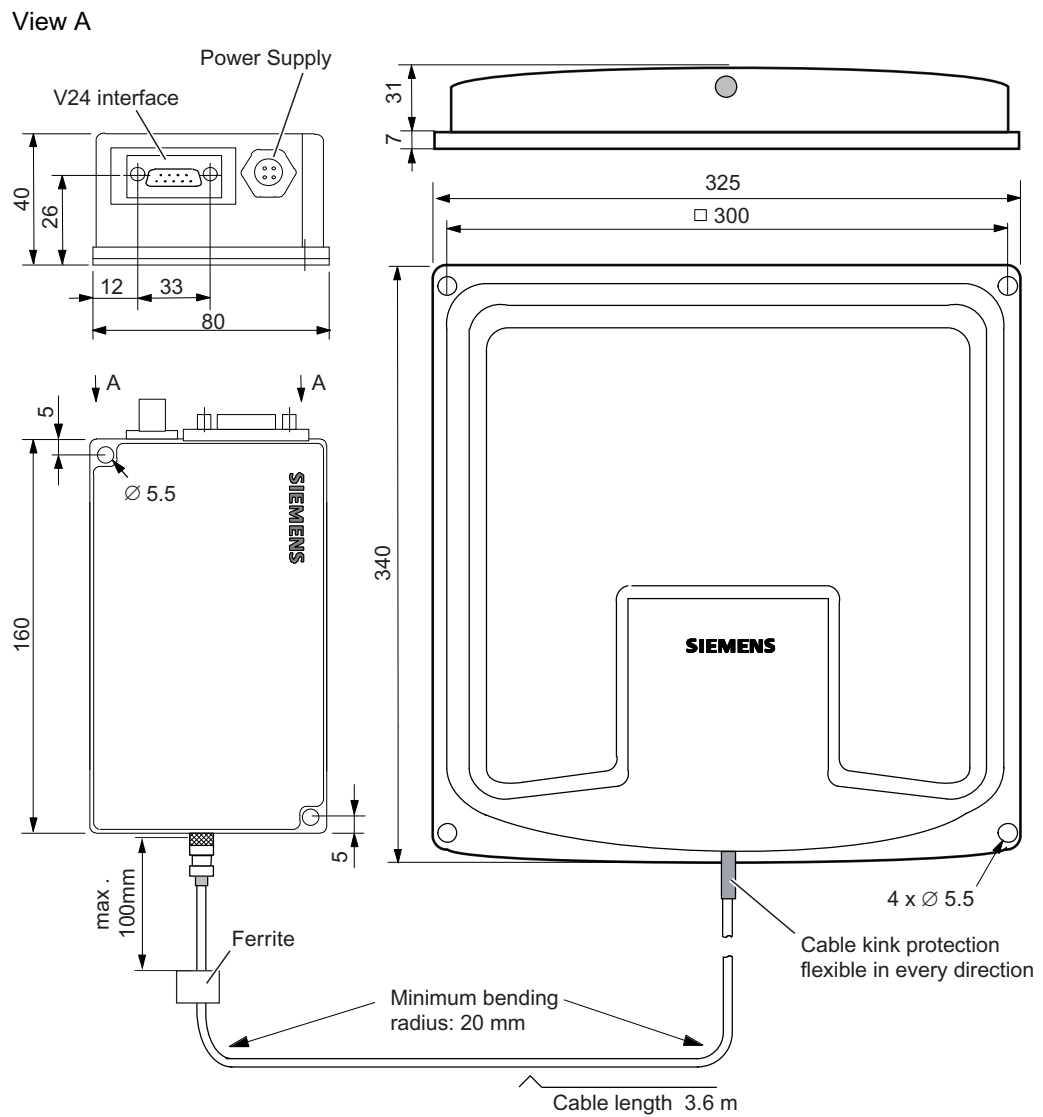

Figure C-27 Dimension drawing for SLG D11S ANT D5

Note

In order to guarantee optimum field data even in the vicinity of metal, ANT D5 is calibrated at the factory at a distance of 100 mm from metal.

Spacer kit for MOBY D ANT D5

See Section *SLG D10 basic unit, spacer kit for MOBY D ANT D5*.

List of abbreviations

CE	Communauté Européenne: CE mark
FCC	Federal Communications Commission
IC	Industry Canada
Lx	Field length in X direction
Ly	Field length in Y direction
MDS	Mobile data storage units
SLG	Read/write device
STG	Service and test unit
ASM	Interface module
IEC	International Electrotechnical Commission

VDE	Verband Deutscher Elektrotechniker [Association of German Electrical Engineers]
RFID	Radio Frequency Identification Devices
UL	Underwriter Laboratories, USA
CSA	Canadian Standard Association
EMC	Electromagnetic compatibility
FB	Function block
FC	Function
Sa	Operating distance between MDS and SLG
Sg	Limit distance
L	Length of a transmission window
CP	Intersection of the axes of symmetry of the MDS
UID	Unique Identification. A serial number which identifies the transponder uniquely.

Glossary

Active field

Area with minimum field strength containing the transmission window, as well as the areas in which the field strength is no longer sufficient for data exchange.

Active surface

See active field

Automation system (AS)

A programmable logical controller (PLC) of the SIMATIC S7 system, comprising a central controller, a CPU and various I/O modules.

Byte

A group of bits, normally eight

CE Label

Communauté Européenne (product mark of the European Union)

Communication modules

Communication modules are used to integrate the MOBY identification systems in SIMATIC or SINUMERIK systems, or to connect them to PROFIBUS DP, PC or any other system. Once supplied with the corresponding parameters and data, they handle data communication. They then make the corresponding results and data available. Suitable software blocks (FB/FC for SIMATIC; C libraries for PCs with Windows Professional) ensure easy and fast integration in the application.

Data transmission rate

Unit of measurement for the volume of data transmitted within a unit of time, e.g. bytes/s

Dwell time

The dwell time is the time in which the transponder dwells within the transmission window of a write/read device. The write/read device can exchange data with the transponder during this time.

Dynamic mode

In dynamic mode, the data carrier moves past the write/read device at a traversing rate which depends on the configuration. Various checking mechanisms (CRC, etc.) ensure error-free data transfer even under extreme environmental conditions. A serial connection (up to 300 m) is used to connect the write/read device directly to an interface module, PC, or any other system.

Electromagnetic compatibility

Electromagnetic compatibility is the ability of an electrical or electronic device to operate satisfactorily in an electromagnetic environment without affecting or interfering with the environment over and above certain limits.

EMC directive

Guidelines for electromagnetic compatibility This guideline relates to any electrical or electronic equipment, plant or system containing electric or electronic components.

Equipotential bonding

Potential differences between different parts of a plant can arise due to the different design of the plant components and different voltage levels. It is necessary to compensate for these differences by equipotential bonding. This is done by combining the equipotential bonding conductors of power components and non-power components on a centralized equalizing conductor.

ESD directive

Directive for handling ESDs.

Interface modules (ASM)

See communication modules

Limit distance

The limit distance is the maximum clear distance between the upper surface of the write/read device and the transponder, at which the transmission can still function under normal conditions.

Metal-free area

Distance/area which must be maintained between the transponder and metal in order to prevent interference during data transfer between the transponder and write/read device.

Mobile data storage units (MDS)

See transponder

Multi-tag capability

Multi-tag capability means that a write/read device can communicate simultaneously with different data carriers.

Programmable logic controller (PLC)

The programmable logical controllers (PLC) of the SIMATIC S5 system consist of a central controller, one or more CPUs, and various other modules (e.g. I/O modules).

Reader/writer

See write/read device

Readers

Readers ensure fast, secure data transfer between mobile data storage units and higher-level systems (PLCs, PCs, etc.). The data, energy included, are transmitted inductively across an electromagnetic alternating field or by radio. This principle enables contact-free data transmission, ensures high industrial compatibility and works reliably in the presence of contamination or through non-metallic materials.

RFID systems

SIMATIC RF identification systems control and optimize material flow and production sequences. They identify reliably, quickly and economically, use non-contact data communication technology, and store data directly on the product. They are also resistant to contamination.

Secondary fields

The strength of the secondary fields, which exist in addition to the transmission window, is usually lower than that of the transmission window and depends on the metallic environment. Secondary fields should not be used in configuring.

Static mode

In static mode the transponder is positioned at a fixed distance (maximum: limit distance) exactly above the write/read device.

Transmission distance

Distance between write/read device/antenna and transponder (mobile data storage unit)

Transmission window

Area in which reliable data exchange between transponder and write/read device is possible due to a particular minimum field strength.

Transponder

An invented word from transmitter and responder. Transponders are used on the product, the product carrier, the object, or its transport or packaging unit, and contain production and manufacturing data, i.e. all application-specific data. They follow the product through assembly lines, transfer and production lines and are used to control material flow.

Because of their wireless design, transponders can be used, if necessary, at individual work locations or manufacturing stations, where their data can be read and updated.

Write/read devices (SLG)

See readers

Write/read distance

See transmission distance

Index

A

- ANT connecting cable
 - Antenna connecting cable, 93
- ANT D10
 - Definition of distance D, 214
 - Dimensions, 228
 - Technical data, 211
 - Transmission window, 225
- ANT D5
 - Definition of distance D, 214
 - Technical data, 206, 211
- ANT D6
 - Definition of distance D, 221
 - Technical data, 206, 211
- Antenna duplexer, 277
- Antenna extension cable, 93
- Approvals, 295
- ASM 452
 - Dimensions, 240
 - Operating mode, 233
 - Ordering data, 241
 - Pin assignments, 237
 - PROFIBUS DP address and terminating resistor, 234
 - PROFIBUS DP configuring, 233
 - Reader connection system, 235
 - Technical data, 239
- ASM 473
 - Design and function, 243
 - Dimensions, 251
 - Hardware configuration, 246
 - Ordering data, 252
 - Pin assignments, 248
 - Reader connection system, 247
 - Technical data, 250
- ASM 475
 - Assignment for connecting cable, 259
 - Configuration, 255
 - Design and function, 253
 - Indicator elements, 257
 - Ordering data, 262
 - Pin assignment, 259
 - Reader connection system, 258
 - Technical data, 261
 - wiring, 255

C

- Cabinet configuration, 75
- Cable
 - Shielding, 81
- Cable configuration, 85
- Certificates, 295
- Communication
 - with the SLG, 30
- Contact partner, 299
- Coupling paths, 74
- Courses, 300

E

- Electromagnetic compatibility
 - Coupling paths, 74
- Electromagnetic interference, 71
- EMC Guidelines, 297
 - Avoiding interference, 78
 - Basic Rules, 70
 - Cabinet configuration, 75
 - Cable shielding, 81
 - Definition, 69
 - Equipotential bonding, 79
 - Overview, 68
 - Propagation of electromagnetic interference, 71
- Equipotential bonding, 79

F

- Field data, 33
- Fixing pocket
 - for MDS D100, 101

I

- Interference sources
 - Electromagnetic, 72

L

- LEDs
 - For MOBY, 248
 - for PROFIBUS DP, 248

- M**
- MDS
 - Memory division, 97
- MDS D124
 - Dimensions, 304
 - Field data, 304
 - Metal-free area, 305
 - Ordering data, 302
 - Technical data, 303
- MDS D139
 - Dimensions, 309
 - Field data, 308
 - Metal-free area, 310
 - Ordering data, 306
 - Technical data, 307
- Metal-free area, 40
 - Flush-mounting, 41
 - Mounting on metal, 41
- MOBY antenna distributor
 - Design and function, 277
 - Ordering data, 277
 - Technical data, 278

- O**
- Ordering data
 - SLG D11, 157
 - SLG D11 accessories, 157

- P**
- Pin assignment
 - SLG D1x (RS 232), 86
 - SLG D1xS (RS 422), 88

- S**
- Shield concept, 83
- Shielding, 81
- SLG D10 ANT D5
 - Definition of distance D, 316
 - Field data, 315
 - Metal-free area, 316
 - Ordering data, 312
 - Programming, 151
 - Technical data, 313
 - Transmission window, 315
- SLG D10 basic unit
 - Dimensions, 156
 - Technical data, 154
- SLG D10S ANT D5
 - Definition of distance D, 331
 - Dimensions, 332
 - Field data, 329
 - Metal-free area, 330
 - Ordering data, 326
 - Technical data, 327
 - Transmission window, 330
- SLG D10S basic unit
 - Dimensions, 178
 - Technical data, 176
- SLG D11 ANT D5
 - Definition of distance D, 324
 - Dimensions, 325
 - Field data, 322
 - Metal-free area, 324
 - Ordering data, 319
 - Programming, 151
 - Technical data, 320
 - Transmission window, 323
- SLG D11S ANT D5
 - Definition of distance D, 338
 - Dimensions, 339
 - Field data, 337
 - Metal-free area, 338
 - Ordering data, 334
 - Technical data, 335
 - Transmission window, 337
- SLG D12
 - Definition of distance D, 168
 - Programming, 151
- SLG D12S
 - Definition of distance D, 192
- Spacers, 102

- T**
- Technical documentation
 - On the Internet, 300
- Technical Support, 299
- Tracking
 - Tolerance, 27
- Tracking tolerance, 27
- Training, 300
- Transmission window, 25
 - Impact of metal, 80
 - Reduction of interference due to metal, 51
 - Width, 27
- Transponder
 - Directions of motion, 29

Get more Information

www.siemens.com/simatic-sensors

SIEMENS AG
Industry Sector
Sensors and Communication
Postfach 4848
90026 NÜRNBERG
DEUTSCHLAND

subject to change
J31069-D0147-A6-7618
© Siemens AG 2010

www.siemens.com/automation