



Power Supply Modules

Cat. No. 1771-P3, -P4, -P5 and -P5E

Installation Instructions

To The Installer

This document provides information on:

- pre-installation information
- connecting input power
- setting the power loss time delay (1771-P5E only)
- installing the power supplies
- paralleling power supplies
- indicator lights
- troubleshooting
- specifications

Pre-installation Considerations

The 1771-P3 power supply is a single-slot module; and the 1771-P4, -P5 and -P5E power supplies are 2-slot modules. These power supply modules can be used in both series A and B 1771 I/O chassis, subject to the conditions listed below.

- Series A 1771 I/O chassis – You are restricted to the following:

Processor	I/O Chassis	1st Power Supply	2nd Power Supply
Without an integral power supply	1771-A4	1771-P3 – 1st slot group 0 1771-P4, -P5, -P5E – slots 0 and 1	1771-P3 – 1st slot of group 5 1771-P4, -P5, -P5E – slots 8 and 9
With an integral power supply	1771-A4	Not Applicable	1771-P3 – 1st slot of group 4 1771-P4 – group 4 1771-P5, -P5E – not applicable
	1771-A2		1771-P3 – 1st slot of group 3 1771-P4 – group 3 1771-P5, -P5E – not applicable

- Series B (or later) 1771 I/O chassis – You may place this module in any slot of a series B (or later) I/O chassis, except the left-most slot which is reserved for the processor.

Installation Instructions

Power Supply Modules

Cat. No. 1771-P3, -P4, -P5 and -P5E

Important: Do not parallel a 1771-P5 or -P5E power supply and an ac powered processor. Use the same voltage source to power two paralleled units.

- 1772-LSP, -LWP and -LXP processors contain an integral ac input power supply. Therefore, you can add only one additional power supply module.
- 1772-LS, -LW and -LX processors do not contain an integral power supply. You **can** install up to two additional power supply modules. Refer to Table A.

Table A
Power Supply/Processor Usage

Power Supply Cat. No.	1771-AL 1771-AR ² 1771-ASB	1771-AS	1772-LN1, -LN2, -LN3, -LV	1772-LS 1772-LW 1772-LX	1772-LSP ¹ 1772-LWP ¹ 1772-LXP ¹
1771-P3					
1771-P4					
1771-P5, -P5E					

Where:

	The two components are compatible for use together in a series A or B I/O chassis
	The two components are compatible for use together only in a series B I/O chassis
	Not compatible

¹ Power supply and backup battery included

² Switch 7 of I/O chassis must be turned on. Refer to Remote I/O Adapter Module publication 1771-2.17.

Refer to Table B. You can parallel the power supplies with processors and each other.

Table B
Power Supply Module Current Capabilities

Power Supply Paralleled with	Total Available Backplane Current for I/O Modules			
	1771-P3	1771-P4	1771-P5	1771-P5E
1771-P3	6A	11A		
1771-P4	11A	16A		
1771-P5, -P5E ¹			16A	16A
1772-LSP	5A	10A		
1772-LXP	7A	12A		
1772-LWP	7A	12A		

¹ The 1771-P5 or -P5E power supply is designed to operate in parallel only with another 1771-P5 power supply. The total current capability would be 16A.

To parallel power supply modules, use the power supply paralleling cable, cat. no. 1771-CT.



ATTENTION: Power supply modules have a controlled “soft-start” feature to enhance power supply reliability. During power-up or power-down periods, outputs of certain discrete modules may momentarily change operating state. These modules are:

- Isolated AC (120V) Output Module, cat. no. 1771-OD series A or B
- Isolated AC (220V) Output Module, cat. no. 1771-OR series A
- Contact Output Module cat. no. 1771-OY series A or B
- Contact Output Module cat. no. 1771-OZ series A or B
- DC (5V) Multiplexer Input Module cat no. 1771-IS

Later series of these modules do not change state during power-up or power-down.

Failure to observe this warning may damage equipment and/or injure personnel.

Connecting Input Power

The 1771-P3, -P4, -P5 and -P5E power supply modules require power from an external power source. Refer to Table C for input voltage requirements and output current capability for the individual power supply modules.

Table C
Power Supply Module Input Voltage Requirements

Power Supply Module	Input Voltage Requirements	Output Current
1771-P3	120V ac (97-132V ac)	3A @ 5V
1771-P4	120V ac (97-132V ac)	up to 8A @ 5V
1771-P5	24V dc (20.5-30V dc)	up to 8A @ 5V
1771-P5E	24V dc (20.5-30V dc)	up to 8A @ 5V

Refer to _____ and _____ for input power connections.

Installation Instructions

Power Supply Modules

Cat. No. 1771-P3, -P4, -P5 and -P5E

Setting the Power Loss Time Delay (1771-P5E only)

The 1771-P5E power supply has a selectable **power loss time delay** which helps prevent unnecessary I/O chassis resets due to input power supply dropouts

Power loss time delay is the time period from when the power supply input voltage drops below 20.5V dc to when the power supply resets the processor enable signal on the I/O backplane. When this signal is reset, the resident PLC[®] processor or adapter module stops processing data to/from the modules in the I/O chassis.

You set the configuration jumper as follows:

Set the jumper to this position	For this power loss time delay
JPR1 — Standard (factory default position)	13.6 ms \pm 3.6 ms
JPR2 — Extended	60 ms

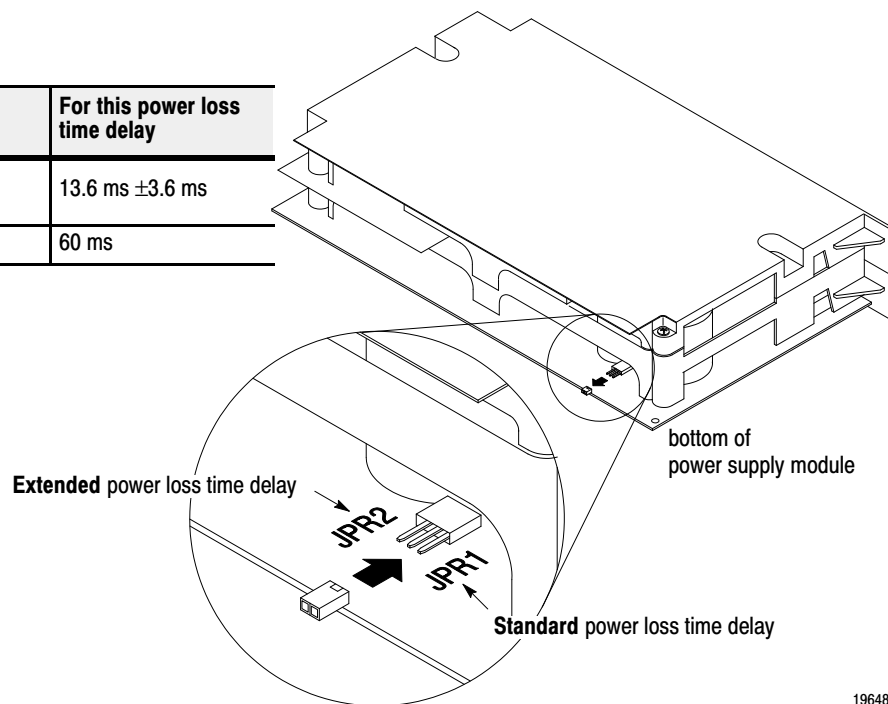

19648

If your input modules and power supply use power from the same source and the input module time delay is greater than the power loss time delay of the power supply module, input module data integrity is preserved.



ATTENTION: Exercise care when you configure your system for possible power loss. You should consider:

- input module time delay
- power loss time delay
- incoming power quality
- control system response to input information

Figure 1
Features of the Power Supply Modules

Cat. No. 1771-P5 and 1771-P5E

Cat. No. 1771-P3

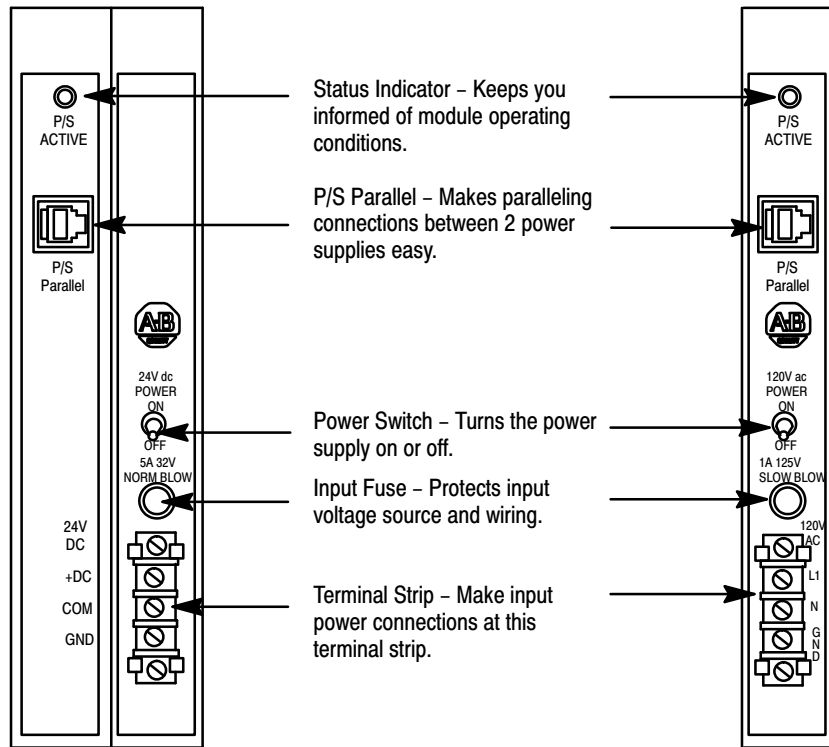

12228-I

Installing the Power Supply

To install the power supply module in the I/O chassis, proceed as follows:



ATTENTION: Turn the power supply OFF before inserting into the I/O chassis. Turn off power to the I/O chassis before inserting this module into the chassis.

- Failure to remove power from the backplane could cause module damage, degradation of performance, or injury.
- Failure to remove power from the backplane could cause injury or equipment damage due to possible unexpected operation.

1. Turn off power to the I/O chassis
2. Turn the power supply module power switch OFF.
3. Place the printed circuit board on the rear of the module into the plastic tracks on the top and bottom of the I/O chassis which guide the module into the chassis.

Installation Instructions

Power Supply Modules

Cat. No. 1771-P3, -P4, -P5 and -P5E

4. Do not force the module into the backplane connectors. Apply firm, even pressure on the module to seat it properly.
5. Snap the chassis latch over the top of the module to secure its position.
6. Make power connections as described in “Making Input Power Connections” below.

Making Input Power Connections

Refer to Figure 2. Proceed as follows.

1. Remove the protective cover from the terminal block by squeezing the prongs and lifting the protective cover.
2. **1771-P3 and -P4** – Connect the L1 (high) line to the top (L1) connection on the terminal block.
1771-P5, -P5E – Connect the positive dc line to the top terminal (DC).
3. **1771-P3 and -P4** – Connect the neutral (low) line to the middle (N) connection on the terminal block.
1771-P5, -P5E – Connect the negative dc line to the middle terminal (COM).
4. **1771-P3 and -P4** – Connect the bottom terminal labeled GND to the ground bus (equipment ground).
1771-P5, -P5E – Connect the bottom terminal (labeled GND) to the ground bus.
5. Replace the protective cover on the terminal block.

Figure 2
Input Power Connections

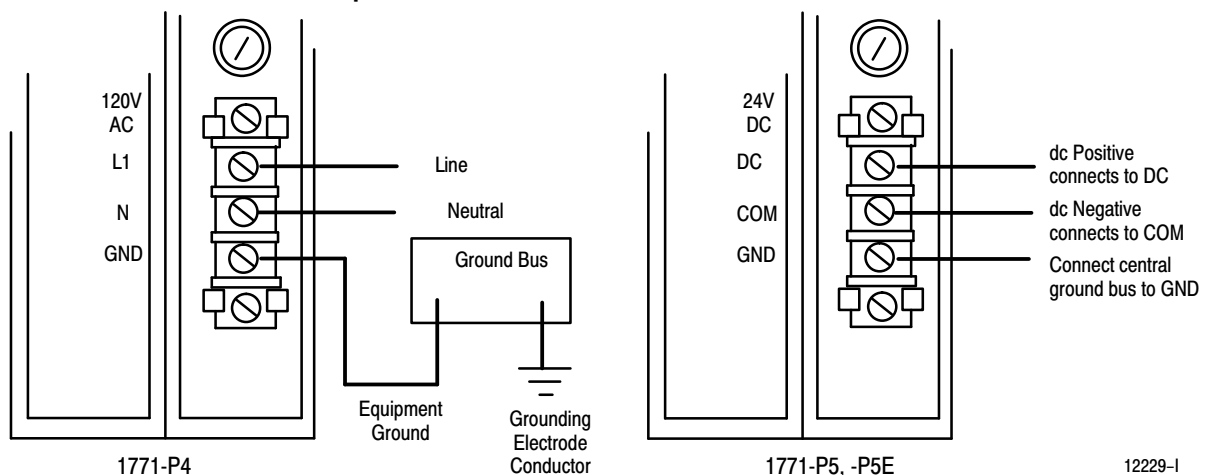

12229-1

Paralleling Power Supplies

The power supply modules are designed to operate in parallel with:

- another 1771-P3, -P4, -P5 or -P5E power supply (**Note:** The 1771-P5, -P5E power supplies are designed to operate in parallel **only** with another 1771-P5.)
- a 1772-LSP, -LWP or -LXP processor

Note: Paralleling two modules, even when using different power sources, does not provide redundancy.

To parallel two modules, proceed as follows:

1. Make certain that both power supply module power switches are off.
2. Connect the power supply paralleling cable (cat. no. 1771-CT) from the P/S Parallel port on the first power supply module to the P/S Parallel port on the second module. **Note:** Route the cable around the top of the I/O chassis to avoid induced voltages.

Figure 3
Paralleling Two Power Supply Modules

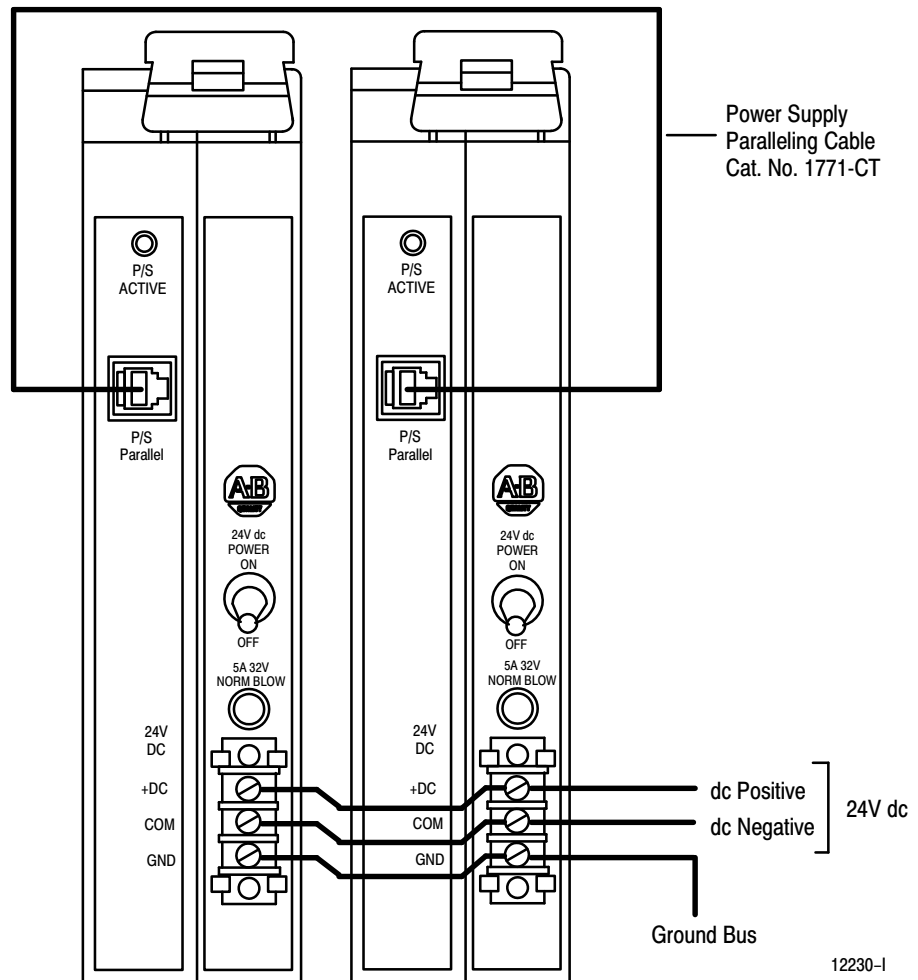

12230-1

Installation Instructions

Power Supply Modules

Cat. No. 1771-P3, -P4, -P5 and -P5E

3. Turn on both power supplies simultaneously.



ATTENTION: To avoid driving the first of two paralleled power supplies into an overcurrent condition that would shutdown the module, you must simultaneously turn on both power supplies.

Module Indicators

The power supply module has a green indicator light (labeled P/S ACTIVE). It indicates the operating condition of the module, and can be used for diagnosing faults.

The module monitors itself for:

- overvoltage
- undervoltage
- overcurrent

Any of these conditions will shut down the power supply. Following a shutdown, turn the power supply off for at least 15 seconds (-P3 and -P4) or 45 seconds (-P5, -P5E) before you turn it on again.

If the P/S ACTIVE Indicator	Then:	Corrective Action
is on	Normal operation. The indicator lights as long as the module is supplied with power even if it is not seated in its chassis slot.	None required.
is off	The module is turned off.	Turn the module on.
turns off	The input voltage to the supply could be below: 97V ac (for 13.6±2.96ms) for a -P3 or -P4 power supply. 20.5V dc (for 13.6±2.96ms) for a -P5 or -P5E power supply.	Allow input power to recover to: 97V ac or above for a -P3 or -P4 power supply 20.5V dc or above for a -P5 or -P5E power supply
turns off and shuts down	The dc output has an overvoltage or overcurrent condition.	<ol style="list-style-type: none">1. Turn the power supply off.2. Wait 15 seconds (-P3 or -P4) or 45 seconds for a -P5 or -P5E.3. Turn the power supply on.
turns off and a paralleled power supply shuts down	The ac input voltage to one of the paralleled power supplies has failed due to loose wire, blown fuse, or the supply has been shut off.	
remains off and at least one power supply shuts down	The two supplies were not turned on simultaneously.	

Troubleshooting

Follow the procedure below to isolate and correct possible faults.

1. Turn the power supply off and wait at least 15 seconds (-P3 and -P4) or 45 seconds (-P5, -P5E) before you turn it on again.
2. Turn the power supply on.
3. If the system operates properly, you are finished. If the indicator does not turn on, turn the power supply off and wait 15 seconds (-P3 and -P4) or 45 seconds (-P5, -P5E).
4. Remove the paralleling cable (if equipped) to verify independent operation of each power supply.



ATTENTION: Remove input power to the I/O chassis before removing the power supply module from the chassis. Failure to do this may result in injury to personnel and/or damage to equipment.

5. Pull the power supplies halfway out of the chassis to test them under no load conditions.
6. Turn on **one** power supply.

If the P/S ACTIVE indicator is:	Then:
On	One or more of the following has occurred: <ul style="list-style-type: none"> - Input voltage was not within acceptable limits - Backplane is overloaded or has a short circuit. Add up the backplane currents of all modules. Verify power supply limits have not been exceeded. - Check for fault in paralleling cable (if used). - Internal power supply could have faulted.
Off	Verify that input voltage is within acceptable limits. If input voltage is correct, replace the power supply.

7. If you have two power supplies in your chassis, repeat step 6 for the other power supply.
8. If you have only one power supply in your chassis and it passed step 7 (the P/S ACTIVE light turned on), verify that the power supply is not overloaded by performing steps 9 through 11.
9. Turn the power supply off and wait 15 seconds (-P3 and -P4) or 45 seconds (-P5, -P5E).
10. Firmly seat the power supply in the chassis.

11. Restore power to the I/O chassis, and turn the power supply module on.

If the P/S ACTIVE indicator is:	Then:
On	The power supply is operating correctly and the system should operate normally.
Off	Replace the power supply module with a known good operating supply. The system should operate normally.

Checking for Open or Shorted Paralleling Cable

Important: Continue with this procedure only if you are using two power supply modules in the same chassis. This procedure checks for an open or shorted 1771-CT paralleling cable.

Before you begin, turn I/O chassis power off. Both power supply modules should be turned off and partially pulled out of the chassis.



ATTENTION: Remove input power to the I/O chassis before removing the power supply module from the chassis. Failure to do this may result in injury to personnel and/or damage to equipment.

1. Test the 1771-CT paralleling cable by verifying the ground connection between power supplies.
2. Test for a short circuit by performing steps 3 through 5.
3. Plug one end of the paralleling cable into one of the power supply modules (the other end should not be connected).
4. Turn the power supply on. If the P/S ACTIVE indicator turns on this end of the cable is okay.
5. Unplug the cable, and plug the other end of the cable into the power supply.

If the P/S ACTIVE indicator :	Then:
Turns On	This end of the cable is all right.
Does not turn On	The paralleling cable has a short circuit. Replace the cable.

6. Perform steps 7 through 9 to test for an open circuit in the paralleling cable.

7. Turn both power supply modules off. Connect the paralleling cable to each supply.
8. Turn one power supply module on. The P/S ACTIVE indicators on both supplies should **not** turn on.
9. Turn the first power supply off and the other power supply module on. The P/S ACTIVE indicators on both supplies should **not** turn on.

 If either of the P/S ACTIVE indicators turn on, the paralleling cable has an open circuit. Replace the cable.
10. To test for a paralleling fault, turn both power supply modules off and wait 15 seconds (-P3 and -P4) or 45 seconds (-P5, -P5E).
11. Verify that the paralleling cable is properly connected, and then turn both power supplies on simultaneously. The P/S ACTIVE indicators on both supplies should turn on.
12. If the P/S ACTIVE indicators on both supplies do not turn on, replace both supplies, one at a time, with known good power supplies in order to isolate the faulty power supply module.
13. If all tests have passed up to this point, turn both power supply modules off simultaneously and wait 15 seconds (-P3 and -P4) or 45 seconds (-P5, -P5E). Check for backplane loading by performing steps 14, 15 and 16.
14. Firmly seat the power supplies in the chassis.
15. Restore power to the I/O chassis, and turn both power supply modules on simultaneously.

If the P/S ACTIVE indicator :	Then:
Turns On	The power supply modules are operating correctly and the system should operate normally.
Does not turn On	Recheck backplane loading.

16. Check for proper dual power supply module operation. If backplane loading is within acceptable limits and the P/S ACTIVE indicators do not turn on, replace both power supply modules, one at a time, with known good power supply modules in order to isolate the faulty module. The system should operate normally.

Installation Instructions

Power Supply Modules

Cat. No. 1771-P3, -P4, -P5 and -P5E

Specifications

	1771-P3	1771-P4	1771-P5	1771-P5E
Module Location	1 slot in a 1771 I/O chassis	2 adjacent slots in a 1771 I/O chassis		
Nominal Input Voltage	120V ac		24V dc	
Input Voltage Range	97 to 132V ac rms		20.5 to 30V dc ¹	
Input Power	23 Watts	57 Watts	57 Watts	
Frequency Range	50/60Hz		Not applicable	
Isolation Voltage	2160V dc for 1s, 1500V rms for 1s (input line to chassis ground)			
Output Voltage	5.06V dc ($\pm 3.8\%$)			
Output Current	3A @ 5V dc maximum	8A @ 5V dc maximum		
Fuse	1A 125V slow blow Bussman MDL1.0 Littelfuse 313001	1.5A 125V slow blow Bussman MDX1.5 Littelfuse 31301.5	5A 32V normal blow Bussman MTH5 Littelfuse 312005	
Power Loss Time Delay – Input Power Loss to Processor Disable	13.6ms (± 3.6 ms)			Adjustable 13.6ms (± 3.6 ms) or 60ms
Agency Approval	UL, CSA	UL, CSA/H		UL, CSA/H, EMI/RFI Standard Conformance ²
Environmental Conditions Operational Temperature Storage Temperature Relative Humidity	0 to 60°C (32 to 140°F) –40 to 85°C (–40 to 185°F) 5 to 95% without condensation			
Weight	1.6 lbs (0.73 kg)	2.3 lbs (1.04 kg)	2.6 lbs (1.18 kg)	
Paralleling Cable	Cat. No. 1771-CT			
Keying – right hand slot	Between 12 and 14 Between 18 and 20	Between 12 and 14 Between 20 and 22	Between 12 and 14 Between 22 and 24	
External Transformer (if used)	60VA	150VA	Not applicable	

¹ Input voltage range includes ripple. Full wave rectified and filtered dc is acceptable if peak to peak ripple is less than 10% of the input voltage.² Conforms to CISPR 11 Class A Radiated Emissions, CISPR 11 Class A Conducted Emissions, 10V/M Radiated Immunity

As a subsidiary of Rockwell International, one of the world's largest technology companies — Allen-Bradley meets today's challenges of industrial automation with over 85 years of practical plant-floor experience. More than 11,000 employees throughout the world design, manufacture and apply a wide range of control and automation products and supporting services to help our customers continuously improve quality, productivity and time to market. These products and services not only control individual machines but integrate the manufacturing process, while providing access to vital plant floor data that can be used to support decision-making throughout the enterprise.

With offices in major cities worldwide

WORLD HEADQUARTERS
Allen-Bradley
1201 South Second Street
Milwaukee, WI 53204 USA
Tel: (1) 414 382-2000
Telex: 43 11 016
FAX: (1) 414 382-4444

EUROPE/MIDDLE EAST/AFRICA HEADQUARTERS
Allen-Bradley Europe B.V.
Amsterdamseweg 15
1422 AC Uithoorn
The Netherlands
Tel: (31) 2975/43500
Telex: (844) 18042
FAX: (31) 2975/60222

ASIA/PACIFIC HEADQUARTERS
Allen-Bradley (Hong Kong) Limited
Room 1006, Block B, Sea View Estate
28 Watson Road
Hong Kong
Tel: (852) 887-4788
Telex: (780) 64347
FAX: (852) 510-9436

CANADA HEADQUARTERS
Allen-Bradley Canada Limited
135 Dundas Street
Cambridge, Ontario N1R 5X1
Canada
Tel: (1) 519 623-1810
FAX: (1) 519 623-8930

LATIN AMERICA HEADQUARTERS
Allen-Bradley
1201 South Second Street
Milwaukee, WI 53204 USA
Tel: (1) 414 382-2000
Telex: 43 11 016
FAX: (1) 414 382-2400