

SIEMENS

SIRIUS

Anwendermodul S45

User module S45

Module utilisateur S45

Módulo de usuario S45

Modulo utilizzatore S45

Módulo do usuário S45

Kullanıcı modülü S45

Операционный модуль S45



3RK1400-1C.0.-0AA2 (4E/4A)

3RK2400-1F.00-0AA2 (4E/3A)

3RK1402-3C.00-0AA2 (4E/4A)

3RK1402-3C.01-0AA2 (4E/4A)

3RK2400-1C.01-0AA2 (4E/4A)



Betriebsanleitung

Operating Instructions

Instructions de service

Instructivo

Istruzioni operative

Instruções de Serviço

İşletme kılavuzu

Инструкция по эксплуатации

Bestell-Nr. / Order No.: 3RK1701-2KB05-0AA8

	Deutsch	English	Français	Español
	Vor der Installation, dem Betrieb oder der Wartung des Geräts muss diese Anleitung gelesen und verstanden werden.	Read and understand these instructions before installing, operating, or maintaining the equipment.	Ne pas installer, utiliser ou intervenir sur cet équipement avant d'avoir lu et assimilé ces instructions.	Leer y comprender este instructivo antes de la instalación, operación o mantenimiento del equipo.
	VORSICHT	CAUTION	PRUDENCE	PRECAUCIÓN
	Eine sichere Gerätefunktion ist nur mit zertifizierten Komponenten gewährleistet.	Reliable functioning of the equipment is only ensured with certified components.	Le fonctionnement sûr de l'appareil n'est garanti qu'avec des composants certifiés.	El funcionamiento seguro del aparato sólo está garantizado con componentes certificados.
	Italiano	Português	Türkçe	Русский
	Leggere con attenzione queste istruzioni prima di installare, utilizzare o eseguire manutenzione su questa apparecchiatura.	Ler e compreender estas instruções antes da instalação, operação ou manutenção do equipamento.	Cihazın kurulumundan, çalıştırılmasından veya bakıma tabi tutulmasından önce, bu kılavuz okunmuş ve anlaşılmış olmalıdır.	Перед установкой, вводом в эксплуатацию или обслуживанием устройства необходимо прочесть и понять данное руководство.
	CAUTELA	CUIDADO	ÖNEMLİ DİKKAT	ОСТОРОЖНО
	Il funzionamento sicuro dell'apparechiatura è garantito soltanto con componenti certificati.	O funcionamento seguro do aparelho apenas pode ser garantido se forem utilizados os componentes certificados.	Cihazın güvenli çalışması ancak sertifikalı bileşenler kullanılması halinde garanti edilebilir.	Безопасность работы устройства гарантировано только при использовании сертифицированных компонентов.

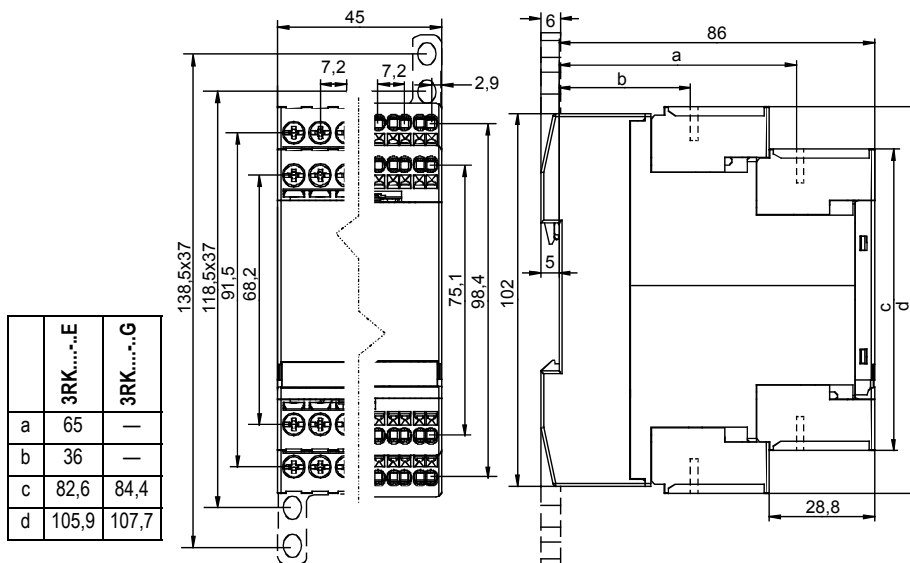

Adresse einstellen
Setting addresses
Réglage de l'adresse
Ajustar dirección
Indirizzamento
Ajustar direcção
Tanzim adres ayarı
здать адрес

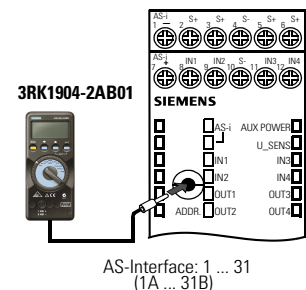

More Information:

www.siemens.com/as-interface
<https://mall.automation.siemens.com>

Technical Assistance:

Telephone: +49 (0) 911-895-5900 (8° - 17° CET)
E-mail: technical-assistance@siemens.com
Internet: www.siemens.de/lowvoltage/technical-assistance

Fax: +49 (0) 911-895-5907

Technical Support:

Telephone: +49 (0) 180 50 50 222

!
1. U = 0 V
2. a, b, c, d

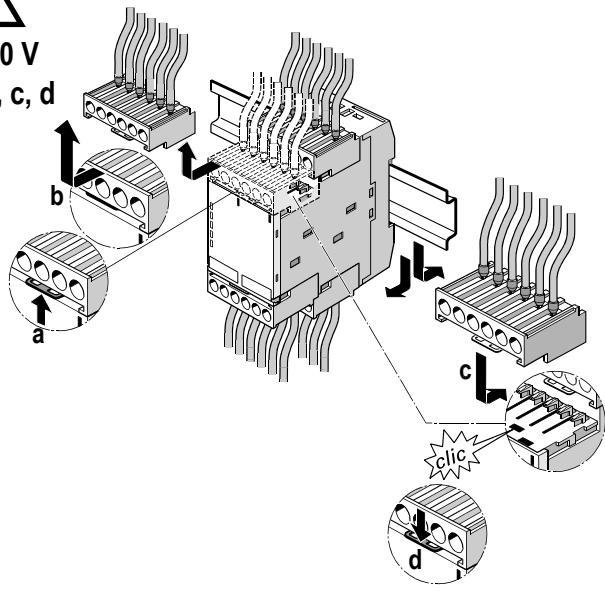

	3RK...-E.	3RK...-G.
 Ø 5 ... 6 mm / PZ2	0,8 ... 1,2 Nm 7 to 10.3 lb·in	—
 10	1 x 0,5 ... 4,0 mm ² 2 x 0,5 ... 2,5 mm ²	2 x 0,25 ... 1,5 mm ²
 10	2 x 0,5 ... 1,5 mm ² 1 x 0,5 ... 2,5 mm ²	2 x 0,25 ... 1,5 mm ²
 10	—	2 x 0,25 ... 1,5 mm ²
AWG	2 x 20 to 14	2 x 24 to 16

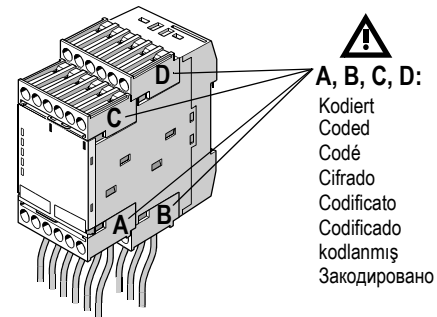
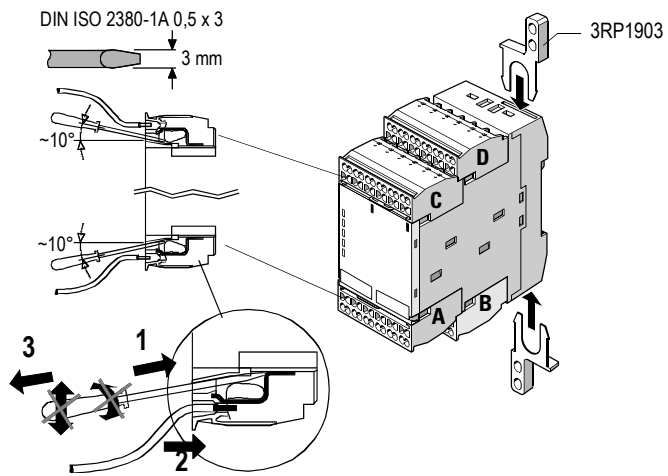

3RK1400-1C.0-0AA2
3RK2400-1C.01-0AA2¹⁾

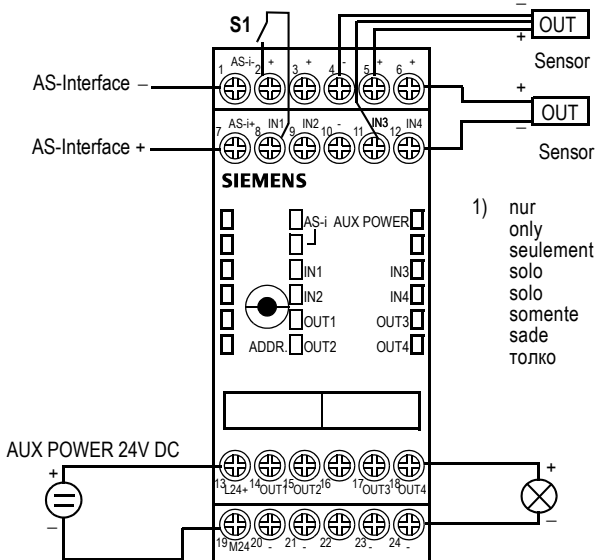

3RK2400-1F.00-0AA2

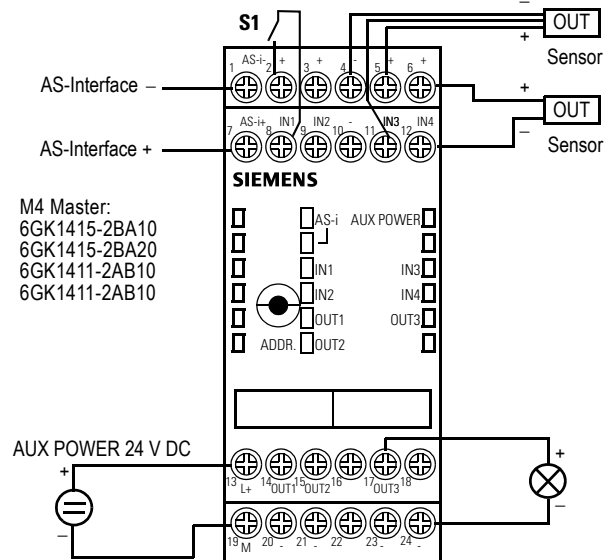

3RK1402-3C.00-0AA2

3RK1402-3C.01-0AA2

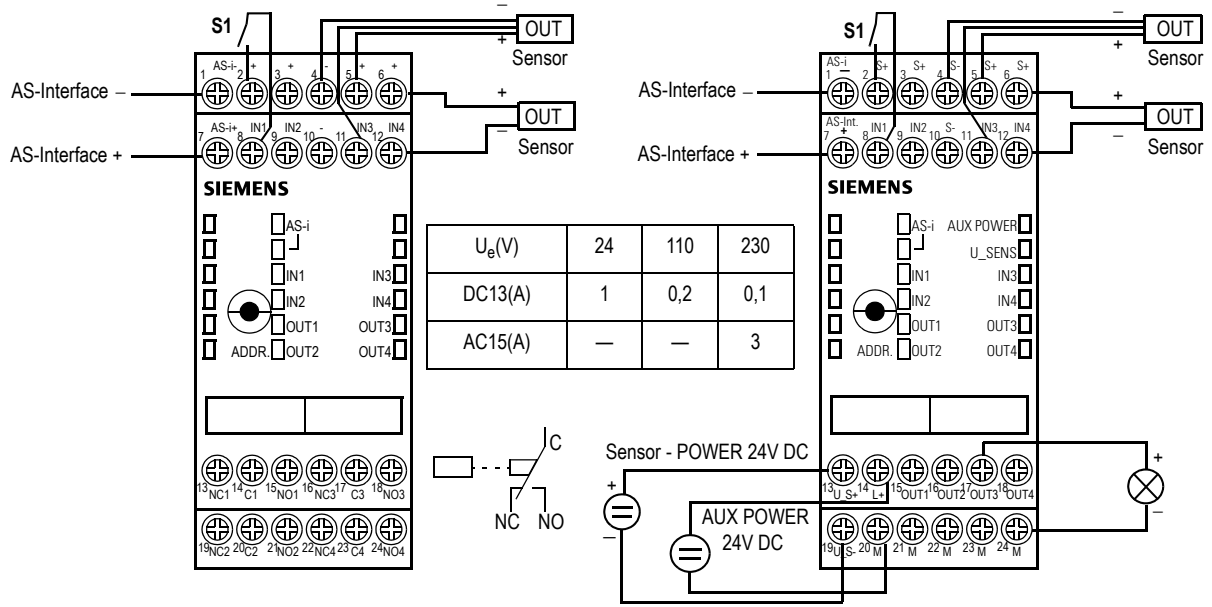

Logische Zuordnung
 Logic assignments
 Affectation logique
 Asignación lógica
 Assegnazione logica
 Atribuição logística
 Mantksal Düzenleme
 Логическое размещение

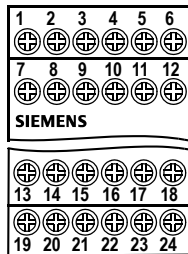

	I0	ID	ID2	ID1
3RK1400-1C.0.-0AA2:	7	0	F	
3RK2400-1F.00-0AA2:	7	A	0	
3RK1402-3C.00-0AA2:	7	0	F	
3RK1402-3C.01-0AA2:	7	0	F	
3RK2400-1C.01-0AA2 ¹⁾ :	7	A	7	7

Terminal	3RK1400-1C.0.-0AA2 3RK2400-1C.01-0AA2 ¹⁾		3RK2400-1F.00-0AA2		3RK1402-3C.00-0AA2		3RK1402-3C.01-0AA2	
	D	I	D	I	D	I	D	I
8	D0	IN1	D0	IN1	D0	IN1	D0	IN1
9	D1	IN2	D1	IN2	D1	IN2	D1	IN2
11	D2	IN3	D2	IN3	D2	IN3	D2	IN3
12	D3	IN4	D3	IN4	D3	IN4	D3	IN4
13								
14	D0	OUT1	D0	OUT1	D0	NC1		
15	D1	OUT2	D1	OUT2		C1		
16					D2	NO1	D0	OUT1
17	D2	OUT3	D2	OUT3		NC3	D1	OUT2
18	D3	OUT4	—	—		C3	D2	OUT3
19					D1	NO3	D3	OUT4
20						NC2		
21					D3	C2		
22						NO2		
23						NC4		
24						C4		

1) nur / only / seulement / solo / solo / somente / sade / только M4 Master: 6GK1415-2BA10, 6GK1415-2BA20, 6GK1411-2AB10, 6GK1411-2AB10

Status LEDs / Status LEDs / LED d'état / LEDs de estado / LED di stato / LEDs de estado / Statü LEDs / состояние светодиода: 3RK1400-1C.0.-0AA2 / 3RK2400-1F.00-0AA2 / 3RK1402-3C.00-0AA2 / 3RK2400-1C.01-0AA2					
AS-Interface grün / (green) verte / verde yeşil / зелёный					
FAULT rot / red rouge / rojo rosso / vermelho kapalı / выключено					
Betriebszustand	Kommunikation in Ordnung	Keine Spannung am AS-Interface-Chip	Kommunikation ausgefallen	Slave hat Adresse "0"	Überlast Sensorversorgung
Operating state	Communication OK	No voltage present at AS-Interface chip	Communication failed	Slave has address "0"	Overload of sensor supply
Etat	Communication O.K.	ASIC AS-Interface non alimenté	Communication perturbée	Esclave avec adresse "0"	Surcharge alimentation des capteurs
Estado de servicio	La comunicación esta O.K.	No hay tensión en el chip AS-Interface	Falla la comunicación	El esclavo tiene dirección "0"	Sobrecarga en la alimentación de los sensores
Stato di funzionamento	Comunicazione in ordine	Manca tensione su chip AS-Interface	Comunicazione interrotta	Slave ha indirizzo "0"	Sovraccarico alimentazione sensorio
Estado de funcionamento	Comunicação em ordem	Nenhuma tensão no chip AS-Interface	Falha na comunicação	O escravo tem endereço "0"	Sobrecarga na alimentação do sensor
İşletme durumu	İletişim düzenli	AS-Interface çipinde-gerilim yok	İletişim devre dışı	Slave'in tanzim adresi "0"	Aşırı akım yükü sensörbeslemesi
Рабочее состояние	Передача данных в порядке	Отсутствие напряжения на чипе AS-Interface	Передача данных прекращена	Адрес ведомого устройства (Slave) "0"	Перенагрузка сенсорного обеспечения

Status LEDs / Status LEDs / LED d'état / LEDs de estado / LED di stato / LEDs de estado / Statü LEDs / состояние светодиода: 3RK1402-3C.01-0AA2				
AS-Interface grün / (green) verte / verde yeşil / зелёный				
FAULT rot / red rouge / rojo rosso / vermelho kapalı / выключено				
Betriebszustand	Kommunikation in Ordnung	Keine Spannung am AS-Interface-Chip	Kommunikation ausgefallen	Slave hat Adresse "0"
Operating state	Communication OK	No voltage present at AS-Interface chip	Communication failed	Slave has address "0"
Etat	Communication O.K.	ASIC AS-Interface non alimenté	Communication perturbée	Esclave avec adresse "0"
Estado de servicio	La comunicación esta O.K.	No hay tensión en el chip AS-Interface	Falla la comunicación	El esclavo tiene dirección "0"
Stato di funzionamento	Comunicazione in ordine	Manca tensione su chip AS-Interface	Comunicazione interrotta	Slave ha indirizzo "0"
Estado de funcionamento	Comunicação em ordem	Nenhuma tensão no chip AS-Interface	Falha na comunicação	O escravo tem endereço "0"
İşletme durumu	İletişim düzenli	AS-Interface çipinde-gerilim yok	İletişim devre dışı	Slave'in tanzim adresi "0"
Рабочее состояние	Передача данных в порядке	Отсутствие напряжения на чипе AS-Interface	Передача данных прекращена	Адрес ведомого устройства (Slave) "0"

3RK1400-1C.0.-0AA2 / 3RK2400-1F.00-0AA2 / 3RK1402-3C.01-0AA2 / 3RK2400-1C.01-0AA2 Hilfsspannung / Auxiliary voltage / Tension auxiliaire / Tensión auxiliar / tensione ausiliaria / tensão auxiliar / Yardımcı gerilim / оперативное напряжение	
AUX POWER	grün / green / verte / verde / yeşil / зелёный