



ET 200M Marshaled Termination Assemblies Remote I/O Modules



Manual

Overview	1
Installation	2
Maintenance	3
8-Channel Analog Input MTA	4
8-Channel Analog Input MTA	5
8-Channel Analog Output MTA	6
8-Channel RTD Input MTA	7
8-Channel TC Input MTA	8
6-Channel F Analog Input MTA	9
6-Channel F Analog Input HART MTA	10
6-Channel F Analog Input HART MTA	11
16-Channel, 24 VDC Discrete Input MTA	12
12/24-Channel, 24 VDC F Discrete Input MTA	13
10-Channel, 24 VDC F Discrete Output MTA	14
16-Channel, 24 VDC Discrete Output MTA	15
16-Channel, 24 VDC Discrete Output MTA	16
Failsafe 10-Channel, 24-150 VDC/120-230 VAC Relay Output MTA	17
16-Channel, 24-150 VDC/120-230 VAC Relay Output MTA	18
Power Monitor Board	19
8-Channel HART Analog Input MTA	20
8-Channel HART Analog Output MTA	21
16-Channel, 24 VDC Power Supply MTA	22
Previous MTA Revisions	23
Safety Information for US Customers	24

Legal information

Warning notice system

This manual contains notices you have to observe in order to ensure your personal safety, as well as to prevent damage to property. The notices referring to your personal safety are highlighted in the manual by a safety alert symbol, notices referring only to property damage have no safety alert symbol. These notices shown below are graded according to the degree of danger.

 DANGER
indicates that death or severe personal injury will result if proper precautions are not taken.
 WARNING
indicates that death or severe personal injury may result if proper precautions are not taken.
 CAUTION
with a safety alert symbol, indicates that minor personal injury can result if proper precautions are not taken.
CAUTION
without a safety alert symbol, indicates that property damage can result if proper precautions are not taken.
NOTICE
indicates that an unintended result or situation can occur if the corresponding information is not taken into account.

If more than one degree of danger is present, the warning notice representing the highest degree of danger will be used. A notice warning of injury to persons with a safety alert symbol may also include a warning relating to property damage.

Qualified Personnel

The product/system described in this documentation may be operated only by **personnel qualified** for the specific task in accordance with the relevant documentation for the specific task, in particular its warning notices and safety instructions. Qualified personnel are those who, based on their training and experience, are capable of identifying risks and avoiding potential hazards when working with these products/systems.

Proper use of Siemens products

Note the following:

 WARNING
Siemens products may only be used for the applications described in the catalog and in the relevant technical documentation. If products and components from other manufacturers are used, these must be recommended or approved by Siemens. Proper transport, storage, installation, assembly, commissioning, operation and maintenance are required to ensure that the products operate safely and without any problems. The permissible ambient conditions must be adhered to. The information in the relevant documentation must be observed.

Trademarks

All names identified by ® are registered trademarks of the Siemens AG. The remaining trademarks in this publication may be trademarks whose use by third parties for their own purposes could violate the rights of the owner.

Disclaimer of Liability

We have reviewed the contents of this publication to ensure consistency with the hardware and software described. Since variance cannot be precluded entirely, we cannot guarantee full consistency. However, the information in this publication is reviewed regularly and any necessary corrections are included in subsequent editions.

Preface

Purpose of this Manual

This manual contains information on the use of Siemens Marshalled Termination Assemblies (MTAs) to adapt field wiring to ET200M remote I/O modules. Specifically designed for standard and failsafe I/O modules used in ET 200M assemblies, these field termination solutions support analog inputs and outputs, discrete inputs and outputs, and relay outputs.

Basic Knowledge Required

To understand this manual, you will require a basic knowledge of Siemens SIMATIC PCS 7 systems, S7-400H Systems, and ET200M I/O Modules.

Related Manuals

Additional information can be found in the following manuals:

- Programmable Logic Controllers S7-300 Module Data (ET200M I/O Module Data)
- Automation System S7-400H Fault Tolerant Systems
- Automation Systems S7-300 Fail-Safe Signal Modules (ET200M Fail-Safe I/O Modules)
- Process Control Systems PCS7 Engineering System
- Process Control System PCS7 Fault Tolerant Control System
- S7-300 CPU 31xC and CPU 31x: Installation, Reference order number A5E00105491-06

Scope of the Manual

This publication does not purport to cover all details or variations in equipment, or to provide for every possible contingency to be met in connection with installation, operation, or maintenance. Should further information be desired or should particular problems arise which are not covered sufficiently for the purchaser's purposes, the matter should be referred to one of the support groups listed in the Product Support section of this manual.

The contents of this manual shall not become part of or modify any prior or existing agreement, commitment or relationship. The sales contract contains the entire obligation of Siemens. The warranty contained in the contract between the parties is the sole warranty of Siemens. Any statements continued herein do not create new warranties or modify the existing warranty.

This manual provides the following basic installation information for adapting field wiring to Siemens MTAs for interface with ET 200M remote I/O modules:

- MTA descriptions and diagrams
- Installation requirements
- Technical specifications
- Maintenance information

Approvals

Marshaled Termination Assembly	Part Numbers	Agency Approvals
Analog Input 8-Channel 16 bit	6ES7650-1AA50-2XX0	CE EMC in accordance with EN61000-6-2 EN61000-6-4 ATEX in accordance with EN600079-0 EN600079-15
	6ES7650-1AA51-2XX0	
	6ES7650-1AA52-2XX0	
Analog Output 8-Channel 12 bit	6ES7650-1AB50-2XX0	Safety: ⁶⁾ EN 61131-2:2007
	6ES7650-1AB51-2XX0	
RTD Input 8-Channel	6ES7650-1AG50-2XX0	FM Approved: FM3600, FM3611, FM3810
	6ES7650-1AG51-2XX0	
TC Input 8-Channel	6ES7650-1AF50-2XX0	Class I, Division 2, Groups A,B,C,D; Temperature code T4A at Ta = 60°C
	6ES7650-1AF51-2XX0	
Discrete Input 16-Channel 24 VDC	6ES7650-1AC10-3XX0	Class I, Zone 2, Group IIC; Temperature code T4 at Ta = 60°C
	6ES7650-1AC11-3XX0	
F Relay Output ⁴⁾ 10-Channel 24-150 VDC 120-230 VAC	6ES7650-1AM30-6XX0 ^{6) 7) 10)}	cULus - UL508, CSA C22.2 No.142 cULus haz.loc. - UL1604, CSA C22.2 No.213 ¹¹⁾ ISA 12.12.01, CSA C22.2 No.213
	6ES7650-1AM31-6XX0 ^{6) 7) 10) 12)}	
Relay Output 16-Channel 24-150 VDC 120-230 VAC	6ES7650-1AM30-3XX0 ^{6) 7) 10)}	ATEX in accordance with EN 60079-15 and EN 60079-0 II 3 G Ex nA II T4 Gc T/C & RTD MTA II 3 G Ex nC IIC T4 Gc All others
	6ES7650-1AM31-3XX0 ^{6) 7) 10)}	
F Analog Input ⁴⁾ 6-Channel Failsafe	6ES7650-1AH50-5XX0	RCM Mark
	6ES7650-1AH51-5XX0	
F Analog Input HART ⁴⁾ 6-Channel Failsafe	6ES7650-1AH61-5XX0	Temperature Range -25 to 60°C ²⁾ TÜV (Functional Safety) IEC61508 (SIL3, Relay MTA's SIL 2) ³⁾ Accessory TÜV when used with any Failsafe MTA ⁴⁾ Accessory - used with F Analog Input ⁵⁾ Accessory - used with F Analog Input MTA
	6ES7650-1AH62-5XX0 ^{11) 12)}	
F Discrete Input ⁴⁾ 12/24-Channel Failsafe 24 VDC	6ES7650-1AK10-7XX0	⁶⁾ UL60079-15 instead of UL1604 ⁷⁾ Class I, Division 2, Groups A,B,C,D; Temperature code T4 ⁹⁾ Not for use on MTAs with covers ¹⁰⁾ See manual for special temperature restrictions
	6ES7650-1AK11-7XX0 ¹²⁾	
F Discrete Output ⁴⁾ 10-Channel Failsafe 24 VDC	6ES7650-1AL10-6XX0	¹²⁾ Temperature Range -25 to 70°C TÜV (Functional Safety, Safety of machinery) IEC61508:2010 IEC 62061 AMD 2 EN ISO 13849:2015
	6ES7650-1AL11-6XX0 ¹²⁾	
Power Monitor Board ³⁾	6ES7650-1BA02-0XX0 ⁷⁾	
5.6V Diode Board ⁹⁾	6ES7650-1BB50-0XX0 ⁹⁾	
	6ES7650-1BB51-0XX0 ⁹⁾	
6.2V Diode Board ⁹⁾	6ES7650-1BC50-0XX0	
	6ES7650-1BC51-0XX0	
FET Switch Adapter ^{4) 9)}	6ES7650-1BD50-0XX0	
	6ES7650-1BD51-0XX0	
Discrete Output 16-Channel 24 VDC	6ES7650-1AD10-2XX0	
	6ES7650-1AD11-2XX0 ¹¹⁾	
HART Analog Input 8-Channel	6ES7650-1AA61-2XX0 ⁷⁾	
HART Analog Output 8-Channel	6ES7650-1AB61-2XX0 ⁷⁾	

Marshaled Termination Assembly	Part Numbers	Agency Approvals
Power Supply 16-Channel 24VDC	6ES7650-1BE10-3XX0 ¹¹⁾	

Additional Support

If you have questions about the use of products presented in this manual, contact your local Siemens representative:

<http://www.siemens.com/automation/partner>

A&D Technical Support

Available worldwide, 24 hours a day:



United States: Johnson City, TN	Worldwide: Nürnberg	Asia / Australia: Beijing
Technical Support and Authorization Local time: Monday to Friday 8:00 AM to 5:00 PM Telephone: +1 (423) 262 2522 or +1 (800) 333-7421 (USA only) Fax: +1 (423) 262 2289 Support Request: http://www.siemens.com/automation/support-request	Technical Support 24 hours a day, 365 days a year Phone: +49 (180) 5050-222 Fax: +49 (180) 5050-223 E-Mail: ad.support@siemens.com GMT: +1:00 Authorization Local time: Monday to Friday 8:00 AM to 5:00 PM Phone: +49 (180) 5050-222 Fax: +49 (180) 5050-223 Mail to: ad.support@siemens.com GMT: +1:00	Technical Support and Authorization Local time: Monday to Friday 8:00 AM to 5:00 PM Phone: +86 10 64 75 75 75 Fax: +86 10 64 74 74 74 Mail to: ad.support.asia@siemens.com GMT: +8:00
Automation and Drives Service and Support International http://www.siemens.com/automation/service&support		
The languages of the SIMATIC Hotlines and the authorization hotline are generally German and English.		

Service & Support on the Internet

In addition to our paper documentation, we also provide all of our technical information on the Internet at:

<http://www.siemens.com/automation/service&support>

Here, you will find the following information:

- Newsletter providing the latest information on your products
- Exactly the right documents for your needs, which you can access by performing an online search in "Service & Support"
- Forum in which users and experts worldwide exchange ideas
- Your local contact person, who can be accessed in our Contacts database
- Information about local service, repair, and replacement parts. Much more information can be found under "Services."

Contents

1	Overview	17
1.1	System Architecture.....	17
1.2	Marshaled Termination Assemblies (MTAs).....	18
1.3	General Construction and Dimensions.....	20
1.4	Interconnecting Cables.....	22
1.5	Interconnecting Cable Assemblies.....	23
2	Installation	27
	Environmental Considerations.....	29
2.1	Mechanical Installation.....	30
2.2	Electrical Installation.....	30
2.2.1	Cabinet Guidelines.....	30
2.2.2	Wiring Guidelines.....	31
2.3	Installation Procedure.....	32
2.3.1	Without Cover and Frame.....	32
2.3.2	With Cover and Frame.....	32
2.4	Removal Procedure.....	33
2.4.1	Without Cover.....	33
2.4.2	With Cover.....	33
3	Maintenance	35
3.1	Tools and Test Equipment.....	36
3.2	Preventative Maintenance.....	36
3.2.1	Environmental Consideration.....	36
3.2.2	Visual Inspection.....	36
4	8-Channel Analog Input MTA	37
4.1	Description.....	37
4.2	Features.....	37
4.3	Operation.....	38
4.4	Installation Requirements.....	39
4.5	Maintenance.....	39
4.6	8-Channel Analog Input Marshalled Termination Assembly.....	40
4.7	Technical Specifications.....	42
4.8	Module Restrictions.....	43
4.9	Typical Transmitter Connection to Field Terminals.....	43
4.10	Hardware Configuration.....	45
4.10.1	Addresses.....	45
4.10.2	Inputs.....	46
4.10.3	Redundancy.....	47
4.11	Technical Specifications for 8-Channel Analog Input Module (6ES7 331-7NF00-0AB0).....	48
5	8-Channel Analog Input MTA	49
5.1	Description.....	49
5.2	Features.....	49
5.3	Modification vs 8-Channel Analog Input MTA 6ES7650-1AA51-2XX0.....	49
5.4	Operation.....	50
5.5	Installation Requirements.....	51
5.6	Maintenance.....	51
5.7	8-Channel Analog Input Marshalled Termination Assembly.....	52
5.8	Technical Specifications.....	54
5.9	Module Restrictions.....	57
5.10	Typical Transmitter Connection to Field Terminals.....	57
5.11	Hardware Configuration.....	58
5.11.1	Addresses.....	58

5.11.2	Inputs	59
5.11.3	Redundancy.....	60
5.12	Technical Specifications for 8-Channel Analog Input Module (6ES7 331-7NF00-0AB0 / 6ES7331-7NF10-0AB0).....	60
6	8-Channel Analog Output MTA	61
6.1	Description	61
6.2	Features.....	61
6.3	Operation	62
6.4	Installation Requirements	62
6.5	Maintenance	62
6.6	8-Channel Analog Output Marshalled Termination Assembly.....	63
6.7	Technical Specifications	64
6.8	Module Restrictions	65
6.9	Typical Load Connection to Field Terminals	65
6.10	Hardware Configuration.....	66
6.10.1	Addresses	66
6.10.2	Outputs	67
6.10.3	Redundancy.....	68
6.11	Technical Specifications for 8-Channel Analog Output Module (6ES7 332-5HF00-0AB0).....	68
7	8-Channel RTD Input MTA	69
7.1	Description	69
7.2	Features.....	69
7.3	Operation	69
7.4	Installation Requirements	70
7.5	Maintenance	70
7.6	8-Channel, RTD Input Marshalled Termination Assembly	71
7.7	Technical Specifications	72
7.8	Module Restrictions	73
7.9	Typical R & RTD Connection to Field Terminals	74
7.10	Hardware Configuration.....	75
7.10.1	Addresses	75
7.10.2	Inputs – Part 1	76
7.10.3	Inputs – Part 2	77
7.11	Technical Specifications for 8-Channel RTD Input Module (6ES7 331-7PF00-0AB0 & 6ES7 331-7PF01-0AB0).....	77
8	8-Channel TC Input MTA	79
8.1	Description	79
8.2	Features.....	79
8.3	Operation	79
8.4	Installation Requirements	80
8.5	Maintenance	80
8.6	8-Channel TC Input Marshalled Termination Assembly.....	81
8.7	Technical Specifications	82
8.8	Module Restrictions	83
8.9	Typical Thermocouple Connection to Field Terminals	83
8.10	Hardware Configuration.....	84
8.10.1	Addresses	84
8.10.2	Inputs – Part 1	85
8.10.3	Inputs – Part 2	86
8.11	Technical Specifications for 8-Channel TC Input Module (6ES7 331-7PF10-0AB0 & 6ES7 331-7PF11-0AB0).....	86
9	6-Channel F Analog Input MTA	87
9.1	6-Channel F Analog Input MTA	87
9.2	Description	87

9.3	Features.....	87
9.4	Operation	88
9.5	Installation Requirements	90
9.6	Maintenance	91
9.7	6-Channel F Analog Input Marshalled Termination Assembly	92
9.8	Technical Specifications	94
9.9	Module Restrictions	95
9.10	Typical Transmitter Connection to Field Terminals	96
9.11	Hardware Configuration.....	97
9.11.1	Addresses	97
9.11.2	Inputs – Part 1	98
9.11.3	Inputs – Part 2	99
9.11.4	Redundancy.....	100
9.12	Technical Specifications for 6-Channel F Analog Input Module (6ES7 336-1HE00-0AB0).....	100
9.13	Zener Diode Boards.....	101
9.13.1	Description.....	101
9.13.2	Operation	101
9.13.3	Installation Requirements	103
9.13.4	Maintenance	103
9.14	Diode Board Assembly	104
9.15	FET Switch Adapter	106
9.15.1	Description.....	106
9.15.2	Operation	106
9.15.3	Installation Requirements	106
9.15.4	Maintenance	107
9.15.5	Technical Specifications	110
9.16	Input Sharing	111
9.16.1	Description.....	111
9.16.2	Purpose.....	111
9.16.3	Operation	111
9.16.4	FAI MTA to SAI MTA Cable.....	112
9.16.5	Hardware Configuration.....	114
10	6-Channel F Analog Input HART MTA	117
10.1	Description.....	117
10.2	Features.....	117
10.3	Operation	118
10.4	Installation Requirements	120
10.5	Maintenance	120
10.6	6-Channel F Analog Input HART Marshalled Termination Assembly	121
10.7	Technical Specifications	123
10.8	Changes to the Technical Specifications for 6-Channel F ANALOG INPUT HART Module (6ES7 336-4GE00-0AB0)	124
10.9	Typical Transmitter Connection to Field Terminals	125
10.10	Hardware Configuration.....	125
10.11	Technical Specifications for 6-Channel F ANALOG INPUT HART Module (6ES7 336-4GE00-0AB0)	125
10.12	Zener Diode Boards.....	126
10.12.1	Description.....	126
10.12.2	Operation	126
10.12.3	Installation Requirements	128
10.12.4	Maintenance	128
10.13	Diode Board Assembly	130
10.14	Input Sharing	132
10.14.1	Description.....	132
10.14.2	Purpose.....	132
10.14.3	Operation	133

10.14.4	FAIH MTA to SAI MTA Cable	133
10.14.5	Hardware Configuration.....	135
11	6-Channel F Analog Input HART MTA	137
11.1	Description.....	137
11.2	Features.....	137
11.3	Modification vs 6-Channel F Analog Input MTA 6ES7650-1AH61-5XX0	137
11.4	Operation	138
11.5	Installation Requirements	141
11.6	Maintenance	141
11.6.1	Maintenance for 2-wire transducer supply.....	142
11.6.2	6-Channel F Analog Input HART Marshalled Termination Assembly	144
11.7	Technical Specifications	146
11.8	Changes to the Technical Specifications for 6-Channel F ANALOG INPUT HART Module (6ES7 336-4GE00-0AB0)	147
11.9	Typical Transmitter Connection to Field Terminals	148
	Hardware Configuration	149
11.10	Technical Specifications for 6-Channel F ANALOG INPUT HART Module (6ES7 336-4GE00-0AB0)	149
11.11	Input Sharing	150
11.11.1	Description.....	150
11.11.2	Purpose.....	150
11.11.3	Operation	151
11.11.4	FAIH MTA to SAI MTA Cable	151
11.11.5	Hardware Configuration.....	153
12	16-Channel, 24 VDC Discrete Input MTA	156
12.1	Description.....	156
12.2	Features.....	156
12.3	Operation	157
12.4	Installation Requirements	157
12.5	Maintenance	157
12.6	16-Channel, 24 VDC Discrete Input Marshalled Termination Assembly.....	158
12.7	Technical Specifications	159
12.8	Module Restrictions	160
12.9	Typical Transmitter Connection to Field Terminals	161
12.10	Hardware Configuration.....	162
12.10.1	Addresses	162
12.10.2	Inputs	163
12.10.3	Time-of-Day Stamp.....	164
12.10.4	Redundancy.....	165
12.11	Technical Specifications for 16-Channel, 24 VDC Discrete Input Module (6ES7 321-7BH01-0AB0)	165
13	12/24-Channel, 24 VDC F Discrete Input MTA	167
13.1	Description.....	167
13.2	Features.....	167
13.3	Operation	168
13.4	Installation Requirements	168
13.5	Maintenance	168
13.6	Simplified diagram	169
13.7	12/24-Channel, 24 VDC F Discrete Input Marshalled Termination Assembly	171
13.8	Technical Specifications	172
13.9	Technical Specifications	173
13.10	Module Restrictions	174
13.11	Typical Transmitter Connection to Field Terminals	176
13.12	Hardware Configuration.....	177
13.12.1	Addresses	177
13.12.2	Parameters	178

13.12.3	Module Parameters	179
13.12.4	Redundancy.....	181
13.13	Technical Specifications for 12/24-Channel, 24 VDC F Discrete Input Module (6ES7 326-1BK00-0AB0 or 6ES7 326-1BK01-0AB0 or 6ES7 326-1BK02-0AB0).....	182
14	10-Channel, 24 VDC F Discrete Output MTA	183
14.1	Description	183
14.2	Features.....	183
14.3	Operation	184
14.4	Installation Requirements	184
14.5	Maintenance	185
14.6	Simplified diagram	186
14.7	10-Channel, 24 VDC F Discrete Output Marshalled Termination Assembly... ..	187
14.8	Technical Specifications	188
14.9	Technical Specifications	189
14.10	Module Restrictions	190
14.11	Typical Load Connection to Field Terminals	192
14.12	Hardware Configuration.....	192
14.12.1	Addresses	192
14.12.2	Outputs	194
14.12.3	Redundancy.....	195
14.13	Technical Specifications for 10-Channel, 24 VDC F Discrete Output Module (6ES7 326-2BF10-0AB0).....	195
15	16-Channel, 24 VDC Discrete Output MTA	197
15.1	Description	197
15.2	Features.....	197
15.3	Operation	198
15.4	Installation Requirements	198
15.5	198	
15.6	Maintenance	199
15.7	Component Identification	199
15.8	Technical Specifications	200
15.9	Changes to 16-Channel, 24 VDC Discrete Output Module (6ES7 322-8BH01- 0AB0) Specifications.....	202
15.10	Technical Specifications for 16-Channel, 24 VDC Discrete Output Module (6ES7 322-8BH01-0AB0)	203
15.11	Typical Load Connection to Field Terminals	203
15.12	Hardware Configuration.....	204
15.12.1	Addresses	204
15.12.2	Outputs	205
15.12.3	Redundancy.....	206
16	16-Channel, 24 VDC Discrete Output MTA	207
16.1	Description	207
16.2	Features.....	207
16.3	Operation	207
16.4	Installation Requirements	208
16.5	Maintenance	208
16.6	Simplified diagram	210
16.7	Component Identification	211
16.8	Technical Specifications	213
16.9	Changes to 16-Channel, 24 VDC Discrete Output Module (6ES7 322-8BH10- 0AB0) Specifications.....	215
16.10	Technical Specifications for 16-Channel, 24 VDC Discrete Output Module (6ES7 322-8BH10-0AB0)	215
16.11	Typical Load Connection to Field Terminals	216
16.12	Hardware Configuration.....	217
16.12.1	Addresses	217

16.12.2	Outputs	218
16.12.3	Redundancy.....	219
17	Failsafe 10-Channel, 24-150 VDC/120-230 VAC Relay Output MTA	220
17.1	Description.....	220
17.2	Features.....	220
17.3	Operation	221
17.4	Installation Requirements	221
17.5	Maintenance	222
17.6	Simplified diagram	223
17.7	Failsafe 10-Channel, 24-150 VDC/120-230 VAC Relay Output Marshalled Termination Assembly	224
17.8	Technical Specifications	226
17.8.1	Technical Specifications for 6ES7650-1AM30-6XX0	226
17.8.2	Technical Specification for 6ES7650-1AM31-6XX0	227
17.9	Module Restrictions	230
17.9.1	Module Restrictions for 6ES7650-1AM30-6XX0	230
17.9.2	Module Restrictions for 6ES7650-1AM31-6XX0	231
17.10	Typical Load Connection to Field Terminals	232
17.11	Hardware Configuration.....	233
17.11.1	Addresses	233
17.11.2	Outputs	234
17.11.3	Redundancy.....	235
17.12	Technical Specifications for 10-Channel, 24 VDC F Discrete Output Module (6ES7 326-2BF10-0AB0).....	235
18	16-Channel, 24-150 VDC/120-230 VAC Relay Output MTA	237
18.1	Description.....	237
18.2	Features.....	237
18.3	Operation	238
18.4	Installation Requirements	238
18.5	Maintenance	239
18.6	Component Identification.....	240
18.7	Technical Specifications	242
18.8	Changes to 16-Channel, 24 VDC Discrete Output Module (6ES7 322-8BH01-0AB0) Specifications.....	244
18.9	Technical Specifications for 16-Channel, 24 VDC Discrete Output Module (6ES7 322-8BH01-0AB0)	245
18.10	Typical Load Connection to Field Terminals	245
18.11	Hardware Configuration.....	246
18.11.1	Addresses	246
18.11.2	Outputs	247
18.11.3	Redundancy.....	248
19	Power Monitor Board	249
19.1	Description.....	249
19.2	Features.....	249
19.3	Operation	249
19.4	Power Monitor Board	250
19.5	Technical Specifications	251
20	8-Channel HART Analog Input MTA	253
20.1	Description.....	253
20.2	Features.....	253
20.3	Operation	254
20.4	Installation Requirements	255
20.5	Maintenance	255
20.6	8-Channel HART Analog Input Marshalled Termination Assembly	256
20.7	Technical Specifications	257

20.8	Changes to Module Specifications	259
20.9	259	
20.10	Typical Wiring Schemes	260
20.11	Hardware Configuration.....	262
20.11.1	Addresses	262
20.11.2	Inputs	262
20.11.3	Redundancy.....	262
20.12	Technical Specifications for 8-Channel HART Analog Input Module (6ES7 331-7TF01-0AB0)	262
21	8-Channel HART Analog Output MTA	263
21.1	Description	263
21.2	Features.....	263
21.3	Operation	264
21.4	Installation Requirements	264
21.5	Maintenance	264
21.6	8-Channel HART Analog Output Marshalled Termination Assembly.....	265
21.7	Technical Specifications	266
21.8	Module Restrictions	267
21.9	Typical Wiring Schemes	268
21.10	Hardware Configuration.....	269
21.10.1	Addresses	269
21.10.2	Outputs	269
21.10.3	Redundancy.....	269
21.11	Technical Specifications for 8-Channel HART Analog Output Module (6ES7 332-8TF01-0AB0)	269
22	16-Channel, 24 VDC Power Supply MTA	271
22.1	Description	271
22.2	Features.....	271
22.3	Operation	271
22.4	Installation Requirements	272
22.5	Maintenance	272
22.6	Simplified diagram	273
22.7	Component Identification	274
22.8	Technical Specifications	275
22.9	Typical Load Connection to Field Terminals	277
22.10	Hardware Configuration.....	277
23	Previous MTA Revisions	279
23.1	8 Channel Analog Input MTA	279
24	Safety Information for US Customers	281

1 Overview

1.1 System Architecture

Figure 1–1 shows MTAs within the system architecture

Figure 1–1 System Architecture

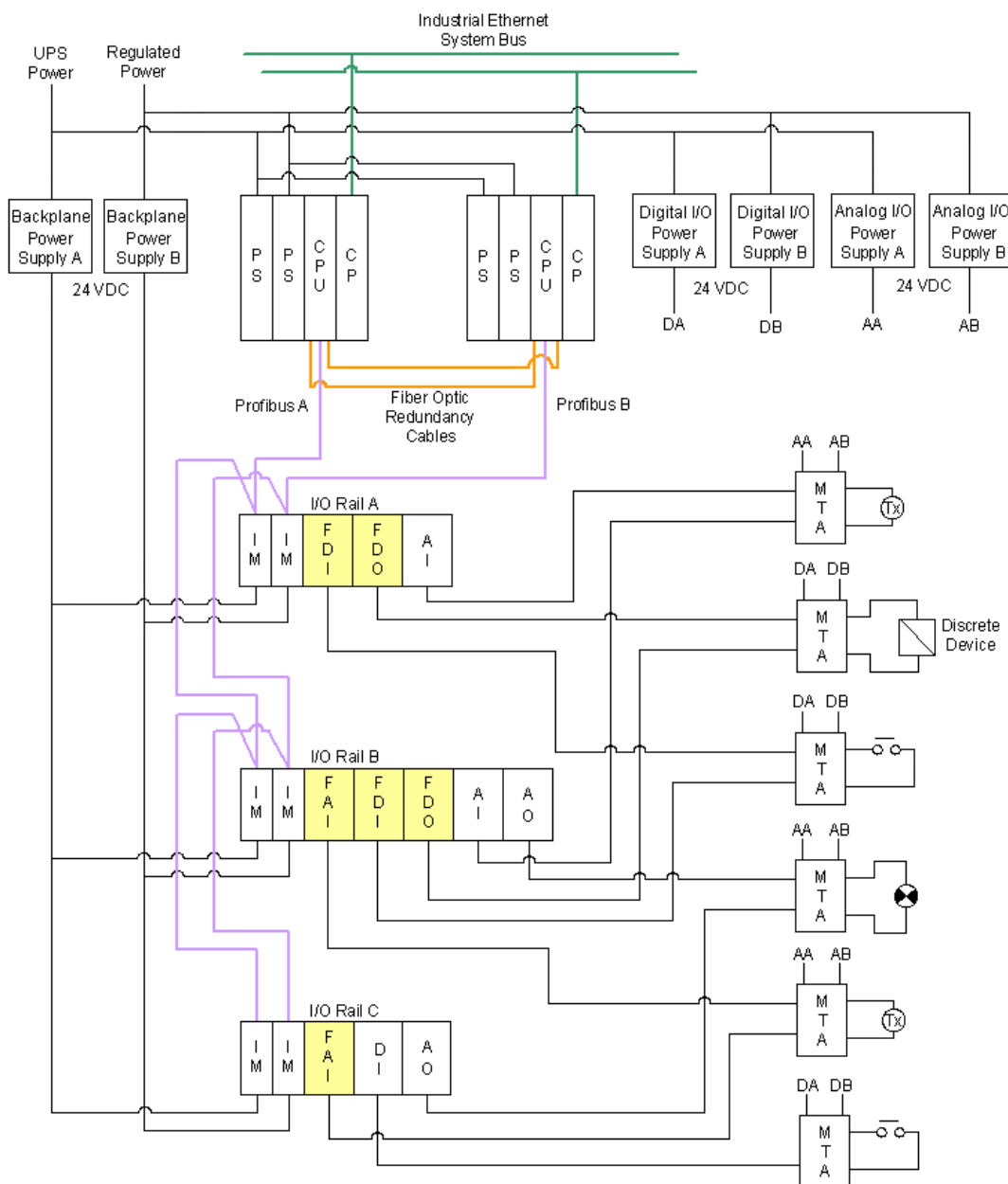

1.2 Marshalled Termination Assemblies (MTAs)

The following table identifies the Siemens Marshalled Termination Assemblies (MTAs) discussed in this manual, including associated SIMATIC PCS 7 ET 200M I/O modules and interconnecting cables.

Table 1–1 Marshalled Termination Assembly and Module Cross-Reference

Marshalled Termination Assembly Part Numbers	PCS 7 ET 200M Module		Redundant
	Description	Part Number	
6ES7650-1AA50-2XX0 6ES7650-1AA51-2XX0	Analog Input 8-Channel 16 bit	6ES7331-7NF00-0AB0, E_Stand 5 or higher	Yes
6ES7650-1AA52-2XX0	Analog Input 8-Channel 16 bit	6ES7331-7NF00-0AB0, E_Stand 5 or higher 6ES7331-7NF10-0AB0, E_Stand 8 or higher	Yes
6ES7650-1AB50-2XX0 6ES7650-1AB51-2XX0	Analog Output 8-Channel 12 bit	6ES7332-5HF00-0AB0, E_Stand 3 or higher	Yes
6ES7650-1AG50-2XX0 6ES7650-1AG51-2XX0	RTD Input 8-Channel	6ES7331-7PF00-0AB0, E_Stand 8 or higher & 6ES7331-7PF01-0AB0	No
6ES7650-1AF50-2XX0 6ES7650-1AF51-2XX0	TC Input 8-Channel	6ES7331-7PF10-0AB0, E_Stand 4 or higher & 6ES7331-7PF11-0AB0	No
6ES7650-1AH50-5XX0 6ES7650-1AH51-5XX0	F Analog Input 6-Channel Failsafe	6ES7336-1HE00-0AB, E_Stand 4 or higher	Yes
6ES7650-1AH61-5XX0 6ES7650-1AH62-5XX0	F Analog Input HART 6-Channel Failsafe HART	6ES7336-4GE00-0AB0	Yes
6ES7650-1AM30-6XX0 6ES7650-1AM31-6XX0	F Relay Output 10-Channel Failsafe 24 VDC	6ES7326-2BF10-0AB0, E_Stand 3 or higher	Yes
6ES7650-1AK10-7XX0 6ES7651-1AK11-7XX0	F Discrete Input 12/24-Channel Failsafe 24 VDC	6ES7326-1BK00-0AB0, & 6ES7326-1BK01-0AB0, E_Stand 1 or higher	Yes
6ES7650-1AC10-3XX0 6ES7650-1AC11-3XX0	Discrete Input 16-Channel 24 VDC	6ES7321-7BH01-0AB0, E_Stand 2 or higher	Yes
6ES7650-1AL10-6XX0 6ES7650-1AL11-6XX0	F Discrete Output 10-Channel Failsafe 24 VDC	6ES7326-2BF10-0AB0, E_Stand 3 or higher	Yes
6ES7650-1AD10-2XX0	Discrete Output 16-Channel 24 VDC	6ES7322-8BH01-0AB0 E_Stand 1 or higher	Yes
6ES7650-1AD11-2XX0	Discrete Output 16-Channel 24 VDC	6ES7322-8BH10-0AB0	Yes
6ES7650-1AM30-3XX0	Relay Output 16-Channel 24 – 150 VDC 120 – 230 VAC	6ES7322-8BH01-0AB0 E_Stand 1 or higher	Yes

Table 1–1 Marshalled Termination Assembly and Module Cross-Reference

Marshalled Termination Assembly Part Numbers	PCS 7 ET 200M Module		Redundant
	Description	Part Number	
6ES7650-1AA61-2XX0	HART Analog Input 8-Channel	6ES7331-7TF01-0AB0	Yes
6ES7650-1AB61-2XX0	HART Analog Output 8-Channel	6ES7332-8TF01-0AB0	Yes
6ES7650-1BE10-3XX0			

1.3 General Construction and Dimensions

Figure 1–2 shows the general construction of a Marshalled Termination Assembly (MTA). There are two basic sizes for MTAs a long version and a short version. Refer to the technical specifications for the MTAs for dimensions. Figure 1–3 shows a typical long version. Only the high voltage versions have covers.

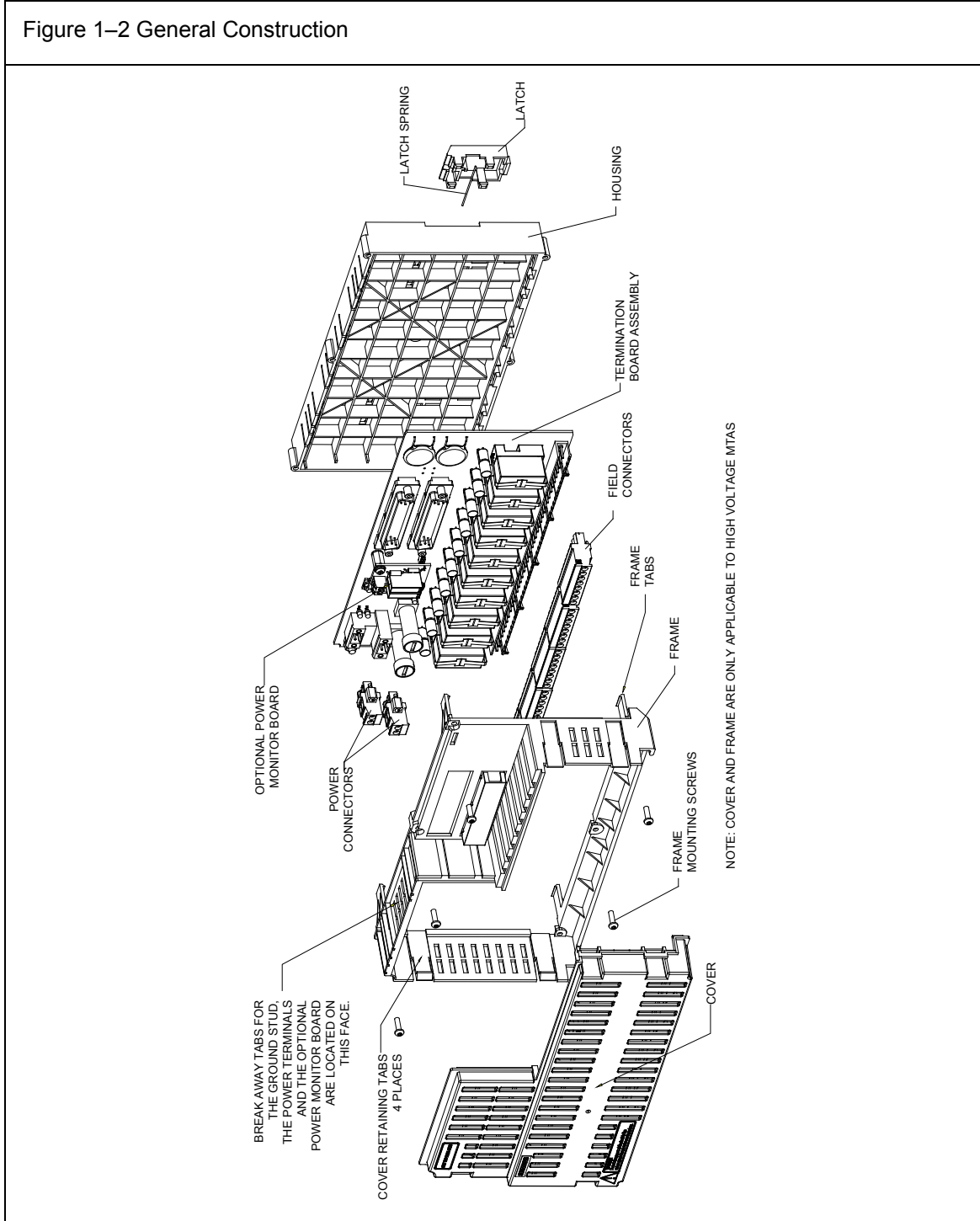
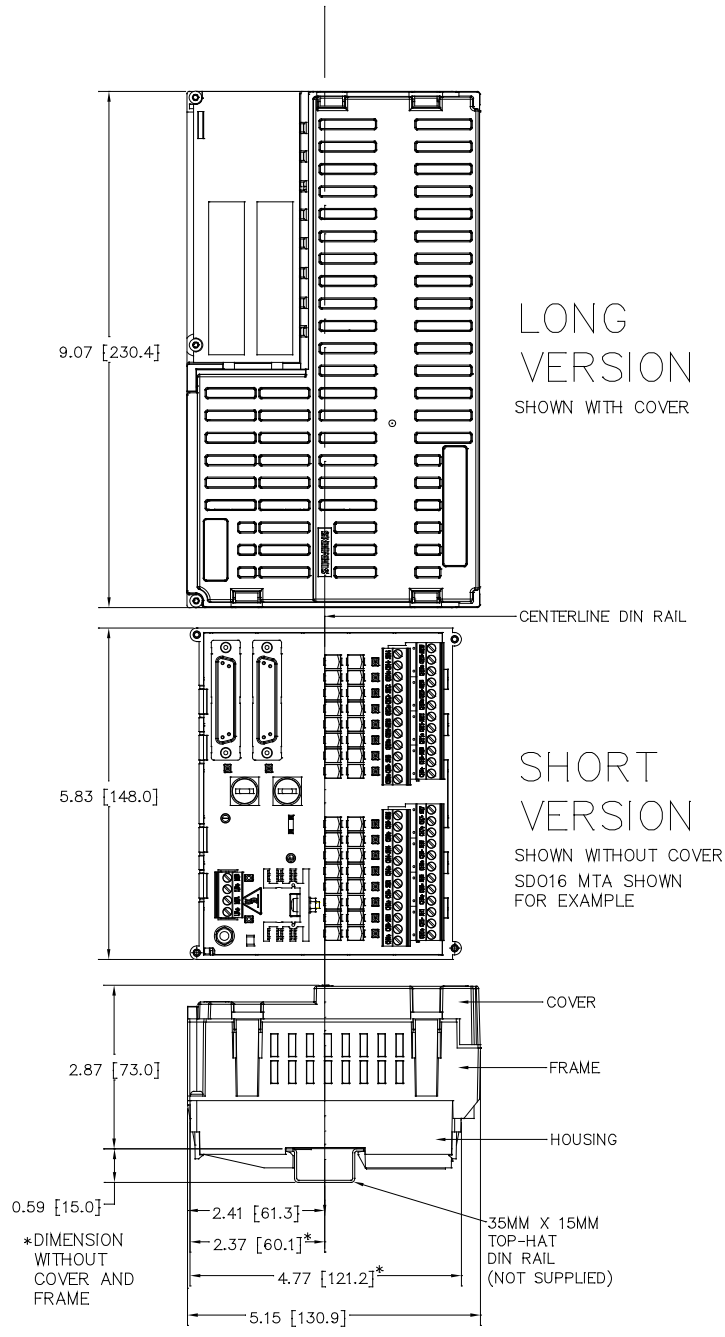

Figure 1-3 Dimensions in inches [mm]



1.4 Interconnecting Cables

Each MTA requires one of five types of interconnecting cable, available in standard lengths of 3 and 8 meters. See the table below.

Table 1–2 Interconnecting Cables

MTA	Interconnecting Cable	
	Description	Order Number
Analog Input 8-Channel	Siemens 40-pin to D25F (6ES7650-1AA52-2XX0)	for connecting 6ES7331-7NF00-0AB0 6ES7922-3BD00-0BA0 (3M Length) 6ES7922-3BJ00-0BA0 (8M Length) for connecting 6ES7331-7NF10-0AB0 6ES7922-3BD00-0BB0 (3M Length) 6ES7922-3BJ00-0BB0 (8M Length)
Analog Input 8-Channel	Siemens 40-pin to D50F	6ES7922-3BD00-0AS0 (3M Length) 6ES7922-3BJ00-0AS0 (8M Length)
Analog Output 8-Channel		
RTD Input 8-Channel		
TC Input 8-Channel		
F Discrete Input 12/24-Channel Failsafe 24 VDC		
F Relay Output 10-Channel 24-150 VDC / 120-230 VAC		
Relay Output 16-Channel 24 – 150 VDC 120 – 230 VAC		
F Analog Input ¹⁾ 6-Channel		
F Analog Input HART ²⁾ 6-Channel	Siemens 20-pin to D50F	6ES7922-3BD00-0AU0 (3M Cable) 6ES7922-3BJ00-0AU0 (8M Cable)
Discrete Input 16-Channel 24 VDC	Siemens 20-pin to D25F	6ES7922-3BD00-0AM0 (3M Length) 6ES7922-3BJ00-0AM0 (8M Length) Or 6ES7922-3BD01-0AM0 (3M Cable) 6ES7922-3BJ01-0AM0 (8M Cable)
F Discrete Output 10-Channel Failsafe 24 VDC	Siemens 40-pin to D25F	6ES7922-3BD00-0AN0 (3M Length) 6ES7922-3BJ00-0AN0 (8M Length)
Discrete Output 16-Channel 24 VDC	Siemens 40-pin to D25M	6ES7922-3BD00-0AT0 (3M Cable) 6ES7922-3BJ00-0AT0 (8M Cable)
HART Analog Input 8-Channel	Siemens 20-pin to D25F	6ES7922-3BD01-0AM0 (3M Cable) 6ES7922-3BJ01-0AM0 (8M Cable)

¹⁾ For use with 6ES7 336-1HE00-0AB, E-Stand 4 or higher only.

²⁾ For use with 6ES7 336-4GE00-0AB0 only.



Caution

It is possible to short-circuit the power pins on the MTA with the shield of the D50 or D25 on the interconnecting cable. Use care when disconnecting the MTA end of the interconnecting cable from a powered MTA. When removing the interconnecting cable, use the following techniques in this order whenever possible:

- Remove power from the MTA.
- Remove the PCS 7 end of the interconnecting cable.
- Remove the MTA end of the interconnecting cable.

1.5 Interconnecting Cable Assemblies

Four interconnecting cables support all the termination assemblies and their respective I/O modules. (See Figures 1-2 through 1-5)

Note

Interconnecting cables are intended for stationary installations only.

Siemens 40 pin to Female Sub-D 50

The most common interconnecting cable uses a 40 pin Siemens ET200M I/O connector wired to a D50 female connector. See Figure 1–4

Figure 1–4 Interconnecting Cable (6ES7922-3BD00-0AS0 or 6ES7922-3BJ00-0AS0)

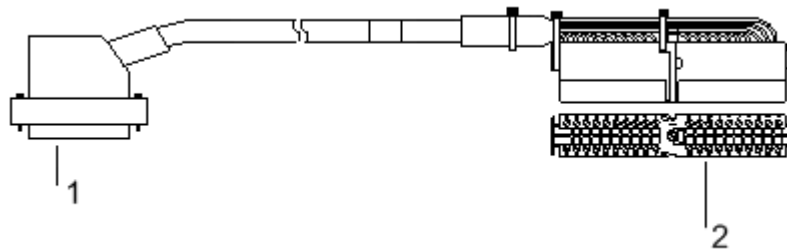

Key to numbered items in Figure 1–4

Item	Part Name
1	50-pin Female Sub-D connector
2	40-pin Siemens connector (6ES7 392-1AM00-0AA0)

Siemens 20 pin to Female Sub-D 25

A second interconnecting cable uses a 20 pin Siemens ET200M I/O connector wired to a D25 female connector. See Figure 1–5

Figure 1–5 Interconnecting Cable (6ES7922-3BD01-0AM0 or 6ES7922-3BJ01-0AM0) and (6ES7922-3BD01-0AM0 or 6ES7922-3BJ01-0AM0)

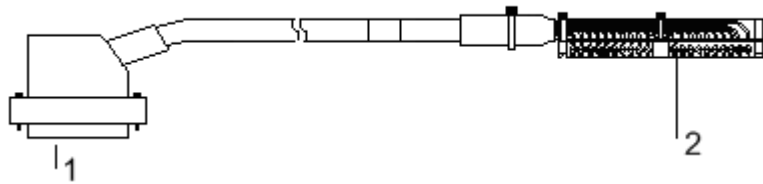

Key to numbered items in Figure 1–5

Item	Part Name
1	25-pin Female Sub-D connector
2	20-pin Siemens connector (6ES7 392-1AJ00-0AA0)

Siemens 40 pin to Female Sub-D 25

A third interconnecting cable uses a 40 pin Siemens ET200M I/O connector wired to a D25 female connector. See Figure 1–6

Figure 1–6 Interconnecting Cable (6ES7922-3BD00-0AN0 or 6ES7922-3BJ00-0AN0, 6ES7922-3BD00-0BA0 or 6ES7922-3BJ00-0BB0 and 6ES7922-3BD00-0BB0 or 6ES7922-3BJ00-0BB0)

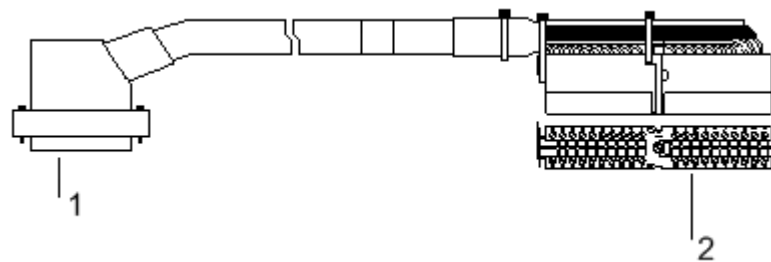

Key to numbered items in Figure 1–6

Item	Part Name
1	25-pin Female Sub-D connector
2	40-pin Siemens connector (6ES7 392-1AM00-0AA0)

Siemens 40 pin to Male Sub-D 25

A fourth interconnecting cable uses a 40 pin Siemens ET200M I/O connector wired to a D25 male connector. See Figure 1–7.

Figure 1–7 | Interconnecting Cable (6ES7922-3BD00-0AT0 or 6ES7922-3BJ00-0AT0)

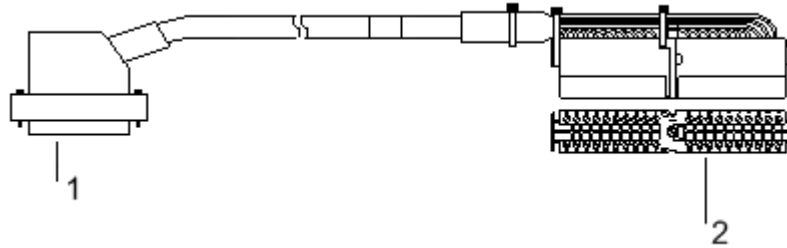

Key to numbered items in Figure 1–7

Item	Part Name
1	25-pin Male Sub-D connector
2	40-pin Siemens connector (6ES7 392-1AM00-0AA0)

Siemens 20 pin to Female Sub-D 50

A fifth interconnecting cable uses a 20 pin Siemens ET200M I/O connector wired to a D50 female connector. See Figure 1–8.

Figure 1–8 Interconnecting Cable (6ES7922-3BD00-0AU0 or 6ES7922-3BJ00-0AU0)

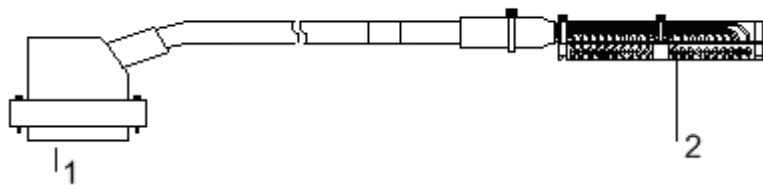

Key to numbered items in Figure 1–8

Item	Part Name
1	50-pin Female Sub-D connector
2	20-pin Siemens connector (6ES7 392-1AJ00-0AA0)

2 Installation

This section describes installation of the ET200M Marshalled Termination Assemblies. Topics include: installation considerations and mechanical and electrical installation.

This equipment is suitable for use in Class I, Division 2, Groups A, B, C, and D OR non-hazardous locations only. Combinations of equipment in your system are subject to investigation by the local Authority having jurisdiction at the time of installation. Installations shall comply with the latest edition of the manufacturer's instruction manual.

Note

- The installation shall comply with the relevant requirements of the National Electrical Code® (ANSI/NFPA 70) and all other applicable construction and electrical codes.
 - For Class I, Div 2 locations, power, input and output (I/O) wiring must be in accordance with Class I, Div. 2 wiring methods per Article 501-10B of the National Electrical Code.
 - Refer to Use of subassemblies/modules in a Zone 2 Hazardous Area Product Information document (19692172) for information on installations in hazardous locations.
 - Tampering and replacement with non-factory components may adversely affect the safe use of the system.
-

Refer to the Preface for Agency Approvals as necessary. Use of the equipment in a manner not specified by the manufacturer may impair the protection provided by the equipment.



Warning

Electrical shock hazard

- An electrical shock hazard exists for Relay Output MTAs only when connected to loads with voltage > 30V rms and 42.4V peak or 60V dc
 - Remove power from all wires and terminals before working on equipment.
-



Warning

Explosion hazard

- Do not connect or disconnect equipment unless power has been removed or the area is known to be non-hazardous.
- Insertion or withdrawal of removable electrical connectors or modules is to be accomplished only when the area is known to be free of flammable vapors.
- Observe all pertinent regulations regarding installation in hazardous area
- WARNING – EXPLOSION HAZARD - Do not disconnect while circuit is live unless area is known to be non-hazardous.
- WARNING – EXPLOSION HAZARD - Substitution of components may impair suitability for Class I, Division 2
- This equipment is suitable for use in Class I, Division 2, Groups A, B, C, and D or non-hazardous locations only
- WARNING: Explosion Hazard. Do not remove or replace fuses unless power has been disconnected or the area is known to be free of ignitable concentrations of flammable gases or vapors.



Caution

Electrostatic discharge can damage or cause the failure of semiconductor devices such as integrated circuits and transistors. The symbol at right may appear on a circuit board or other electronic assembly to indicate that special handling precautions are needed.



- A properly grounded conductive wrist strap must be worn whenever an electronics module or circuit board is handled or touched. A service kit with a wrist strap and static dissipative mat is available from Siemens (PN15545-110). Equivalent kits are available from both mail order and local electronic supply companies.
- Electronic assemblies must be stored in anti-static protective bags when not installed in equipment.

Environmental Considerations

Operate the ET200M MTAs within their environmental specifications to help ensure reliable, trouble-free operation with minimum down time. Refer to the Technical Specifications sections for each MTA's operating temperatures limits, operating humidity, and maximum moisture content.

Temperature

Keep the air surrounding an operating system below 60°C (140°F). Check air temperature periodically to ensure that this specification is not being exceeded.



Caution

Exceeding the specified operating temperature limits can adversely affect performance and may cause damage to the MTA.

Forced air ventilation is possible when MTAs are mounted in a partially or completely enclosed panel or cabinet (for example, NEMA 1). When clean air is present, exhaust fans are often mounted across the top of a panel and louvers formed in the panel bottom. Air is then drawn upward between the station cases. When air contains particulate matter, fans and filters are generally located at the panel bottom and louvers at the top. Filtered air is now forced upward between the station cases. Filters must be serviced periodically.

Only high quality, quiet running fans should be used. Also, the fans should not generate electrical noise which could interfere with electronic instruments.

A sealed cabinet (e.g. NEMA 12 or 4X) containing equipment that does not generate significant heat should contain a recirculating fan for forcing air flow around equipment and throughout the cabinet preventing hot spots from developing. Forced air conditioning may be required in very high density panels or consoles. Periodically change or clean air filters.

Contaminants

The MTA is open to permit circulation of clean cooling air. Liquids and corrosive gases must not be allowed to enter the case. Whether the MTA is in a control room or field mounted it must be protected from rain, air conditioning condensate, and plant and process related fluids and gases. Extended exposure to contaminants can result in malfunctions.

Industrial environments often contain airborne particulate contaminants. Particulate matter, usually dust and dirt, is abrasive and can cause intermittent connections. A layer of dust on circuit boards can interfere with component heat dissipation and can absorb other airborne contaminants. Extended exposure to these contaminants may result in malfunctions.

Although ET200M MTAs have a protective coating, the following steps can reduce contaminant related equipment malfunctions:

1. Identify contaminants and implement methods to reduce their presence.
2. Install protective housing for field mounted units.
3. When cleaning equipment and surrounding area, especially the floor, either vacuum away all dust and dirt or use a dampened rag or mop. Sweeping or dry dusting recirculates dust and dirt.
4. Clean or replace all air conditioning filters, room air filters, and equipment filters regularly.
5. Inform all personnel with access to the equipment of the need for cleanliness.

2.1 Mechanical Installation

The MTA housing is designed to be used with 35mm x 15mm Top Hat style DIN rail.

2.2 Electrical Installation

These sections contain electrical connection details for wiring an ET200M MTA.

The Cabinet Guidelines provide required restrictions for installation inside a cabinet and the Wiring Guidelines contains specific information about connector identification, wire size, wire selection, and wire routing.

2.2.1 Cabinet Guidelines

Installing the MTAs into a cabinet will protect them from stray signals and the environment. There are, however, certain safety agency restrictions that need to be observed.

- The MTA shall be installed in compliance with the enclosure, mounting, and spacing, and segregation requirement of the ultimate application.
- MTA's must be installed in an enclosure or cabinet that provides a degree of protection IP54 or better
- Cabinet or enclosure shall provide sufficient protection from Impact (IEC60079-15, clause 26.3.3.1)
- Enclosure or cabinet must be of metal or meet the requirements of IEC60079-15 for plastic enclosures
- Enclosure or cabinet shall protect MTAs from corrosion
- Enclosure or cabinet shall provide suitable earthing facility in accordance with IEC60079-15 clause 6
- Enclosure or cabinet shall provide suitable cable or conduit entries in accordance with IEC60079-15 clause 6
- Provision must be made to prevent transient disturbances that would exceed 33 V
- Enclosure shall be marked "Do not remove fuses when energized" and "Do not separate connections when energized" in Class I, Division 2, Groups A, B, C, and D or non-hazardous locations.

2.2.2 Wiring Guidelines

Electrical Connections - Power, I/O, and network connections to a system are completed through removable connectors.

For the analog I/O, Discrete Output 16 Channel and Relay Output 16 Channel MTAs the interconnection cable shield must be connected to ground at the I/O module. In environment with great EMC-load the connection made by the connectors may not be sufficient. In this case, after removing the insulation the shield of the cable should be clamped direct to ground. Analog I/O MTAs include analog input, analog output, RTD input, TC input and failsafe analog input MTAs. To ground the shield, the outer insulation must be removed to expose a section of the shield. A shield contact element is installed below the I/O module and the exposed shield placed inside the shield contact element. See S7-300 CPU 31xC and CPU 31x: Installation. Reference order number A5E00105491-06.

Connectors - Power terminals are identified by a letter: L+ and M. The ground connection is made to a Shield stud near the power connector. Signal I/O terminals are identified by function (CH+, PWR), channel number (CH0-CH7) and polarity (+/-).

Power and signal connectors will accept a maximum of #12 AWG / 3.3mm² wire; however, #14 AWG / 2.08mm² is specified throughout this manual for ease of use.

Power Monitor wiring is smaller and will accept a maximum of #16 AWG wire.

Wire Selection - Stranded wire is recommended for most connections, however, solid wire is typically used for thermocouple extension wire. Carefully select wire size, conductor material, and insulation. Some selection considerations are:

- Current and voltage to be carried
- Total length of each wire run
- Whether wire will be bundled or run singly
- Indoor or outdoor installation
- Temperature extremes (Use supply wires suitable for 5°C (10°F) above ambient temperature.)
- Exposure to sunlight
- Vibration
- Types of contaminants

Note

It is recommended that crimp on ferrules with insulating collars be used to terminate stranded field wiring.

Wire Routing and Conduit - DC wiring should be separated from AC wiring and away from AC powered pushbuttons, alarms, annunciators, motors, solenoids, and similar devices. Conduit and raceways are commonly used for routing panel wiring. Wiring not installed in conduit or raceway should be clamped or supported approximately every 12 inches (300 mm).

2.3 Installation Procedure

2.3.1 Without Cover and Frame

Step	Action
1	Mount the MTA to the DIN rail (Recommend 35mm x 15mm Top Hat style)
2	For EMC Compliance connect the MTA Shield stud to earth ground.
3	Plug the interconnecting cable into the PCS7 I/O Modules
4	For analog I/O Modules: Install shield connecting element, strip a section of outer insulation from interconnecting cable and place in shield connecting element
5	Plug the interconnecting cable into the D25 or D50 on the MTA
6	Plug the Field terminal connectors into the MTA
7	Plug the IO power connector into the MTA
8	Apply power

2.3.2 With Cover and Frame

Refer to Figures 1-2 and 2-1

Step	Action
1	Mount the MTA to the DIN rail (Recommend 35mm x 15mm Top Hat style)
2	Remove cover using screw driver to disengage the cover retaining tabs from cover.
3	For EMC Compliance remove the Shield Stud Break-Away Tabs (Fig 1-2) on the frame adjacent to the shield stud to connect the MTA Shield stud to earth ground.
4	Plug the interconnecting cable into the PCS7 I/O Modules.
5	For analog I/O Modules: Install shield connecting element, strip a section of outer insulation from interconnecting cable and place in shield connecting element.
6	Plug the interconnecting cable into the D25 or D50 on the MTA. Remove the Module 2 Break-Away Connector Cover (Fig 2-1) to access the connector for module 2 for redundant configurations.
7	Plug the Field terminal connectors into the MTA.
8	Remove the Power Connection Break Away Tabs (Fig 2-1) on the frame adjacent to the power connection and plug the IO power connector into the MTA.
9	If the Power Monitor Board is used, remove the Power Monitor Break-Away Tabs (Fig 2-1) on the frame adjacent to the Power Monitor Board connector and connect to the Power Monitor Board.
10	Snap cover into place
11	Apply power

2.4 Removal Procedure

Should it be necessary to remove or replace a termination assembly, follow the procedures outlined below.

2.4.1 Without Cover

Step	Action
1	Remove power and signals from the MTA
2	Remove ground connection to MTA shield stud if applied
3	Unplug the interconnecting cable into the D25 or D50 on the MTA
4	Unplug the field terminal connectors into the MTA
5	Unplug the IO power connector into the MTA
6	If the Power Monitor Board is used, remove the connection to the Power Monitor Board or remove the Power Monitor Board for use on a replacement MTA.
7	Remove MTA from DIN rail using screwdriver to release the latch.
8	Follow the installation procedure in section 2.3 to install a replacement MTA.

2.4.2 With Cover

Refer to Figure 1.2

Step	Action
1	Remove power and signals from the MTA
2	Remove cover using screw driver to disengage the cover retaining tabs from cover.
3	Remove ground connection to MTA shield stud if applied
4	Unplug the interconnecting cable into the D25 or D50 on the MTA
5	Unplug the field terminal connectors into the MTA
6	Unplug the IO power connector into the MTA
7	Remove MTA from DIN rail using screwdrivers to release the latches. Latches are accessed through slots in frame.
8	Follow the installation procedure in section 2.3 to install a replacement MTA.

Figure 2-1 Break-Away Connector Cover and Tabs



3 Maintenance

MTA maintenance requirements are minimal. Activities such as cleaning and visual inspections should be performed at regular intervals. The severity of the system's operating environment will determine the frequency of maintenance. Additional topics including troubleshooting, assembly replacement, and software compatibility are also covered.

Before servicing or calibration the equipment, note the following:

- Maintenance should be performed only by qualified personnel. Failure to properly maintain the equipment can result in death, serious injury, or product failure. This manual should be carefully reviewed, understood, and followed.
- The steps in the Preventive Maintenance section should be performed regularly.
- The procedures in this section do not represent an exhaustive survey of maintenance steps necessary to ensure safe operation of the equipment. Particular applications may require further procedures. Should further information be desired or should particular problems arise which are not covered sufficiently for the purchaser's purposes, the matter should be referred to the local Siemens sales office.
- The use of unauthorized parts in the repair of the equipment or tampering by unqualified personnel will result in dangerous conditions that can cause death, serious injury, or equipment damage. Follow all safety instructions contained herein.



Warning

Explosion hazard Can cause death or injury

Substitution of components may impair suitability for Class I, Division 2.

See Section 2, *Installation*, before performing any maintenance and observe all warnings

3.1 Tools and Test Equipment

The following tools and equipment are necessary for servicing:

- Common hand tools for servicing electronic equipment
- Digital Multimeter (DMM)
 - Voltmeter Section:
 - Accuracy +/-0.01% of reading
 - Resolution 1.0 mV input
 - Impedance 10 M Ω
 - Ammeter section:
 - Accuracy +/- 0.1% of reading
 - Resolution 100 μ A
- Maintenance Kit, containing wrist strap and conductive mat.

3.2 Preventative Maintenance

The objective for establishing a preventive maintenance program is to provide maximum operating efficiency.

Every preventive maintenance operation should assist in realizing this objective. Unless a preventive measure reduces a station's down time, it is unnecessary.

3.2.1 Environmental Consideration

The system has been designed to operate within specified environmental parameters (temperature and humidity).

3.2.2 Visual Inspection

As part of a periodic maintenance program, the system should be visually inspected. When viewing the MTA, scan for abnormalities such as loose, broken or stressed cables. Look for damaged circuitry and heat stressed parts. Check for excessive dirt or dust build-up which may impede air flow and inhibit proper heat dissipation.

4 8-Channel Analog Input MTA

Part No. 6ES7650-1AA51-2XX0 or 6ES7650-1AA50-2XX0

4.1 Description

This section contains installation information and requirements for Siemens Marshalled Termination Assembly (MTA) (6ES7650-1AA51-2XX0 or 6ES7650-1AA50-2XX0), which connects to the Siemens ET 200M 8-Channel Analog Input Module (6ES7 331-7NF00-0AB0, E-Stand 5 or higher).

Note: The only major difference between the two part numbers is the housing. The Anthracite Gray housing is the latest design. Functionality of both part numbers is the same.

4.2 Features

This MTA has the following features:

- Redundant power connections
- LED indication of redundant power supply condition
- Power monitor plug-in available (optional)
- LED indication of power supply to the field device on an individual channel basis
- Per channel fusing of field power
- Dual connectors for redundant I/O Module operation
- Shield connections available for channel cabling
- Ground stud for connecting shield to earth ground
- Power input and field terminations are pluggable for easy maintenance
- Connectivity for HART Handheld Terminal (HHT) per channel

4.3 Operation

Power is supplied via the two removable power connectors which are retained by screws and marked **L+A, MA**, and **L+B, MB**. Each has circuitry to detect the presence of voltage over 15 VDC and turn on the LED indicator. The LEDs are marked **A POWER** and **B POWER**. There is also a connector (**J3**) for a Power Monitor board used to indicate the presence of both A and B power. See Section 19, *Power Monitor Board* (6ES7650-1BA02-0XX0).

Incoming power from **A** and **B** is diode OR'd, in **CR106**, to provide the MTA power from either input source. The output from **CR106** is sent to the channel fuses. This module does not require any power from the I/O power supply and therefore no module power circuitry is required.

Each channel has an LED to indicate the presence of power and the fuse status. If there is no power or the fuse is open, then the LED remains dark. If there is power and the fuse is good then the LED is illuminated.

The MTA has two types of jumpers for customer use:

- **I – V** jumpers are a header and shunt type that determines the connection to the input signal.
- Isolation jumpers are wires that can be cut to isolate the input channel from power return. See Section 4.10, *Hardware Configuration*.

Field Terminals, Channel + (**Ix+**), Channel – (**Ix-**), Sensor power (**PWRx**) and Shield (**SHx**), connect to the field devices. **PWRx** is the +24 VDC power feed and is fused (.5A) on a channel-by-channel basis. The field termination connector is removable for ease of wiring maintenance and is retained by friction.

The channel inputs from the MTA connect to the I/O modules inputs via **J1** and **J2**. Redundant operation uses two modules with one each connected to **J1** and **J2**, while non-redundant systems have one module connected to either **J1** or **J2**.

4.4 Installation Requirements

See Section 2, *Installation*, before performing any installation and observe all warnings

A common interconnecting cable (6ES7922-3BD00-0AS0 or 6ES7922-3BJ00-0AS0), supporting eight analog input channels, connects the analog input termination assembly to the 8-channel analog input module (6ES7 331-7NF00-0AB0, E-Stand 5 or higher). See Figure 4–1.

It may be necessary to modify the printed circuit board as follows:

- For channels measuring voltage, move the **I – V** jumper for that channel to the **V** side.
- For channels measuring current, move the **I – V** jumper for that channel to the **I** side
- To separate channel input low from power supply common, cut and remove the jumper associated with that channel, W8 for CH0 through W15 for CH7.

Note

To disconnect the interconnecting cable shield from ground at the MTA only, cut and remove the shield disconnect jumpers, **W100** and **W101**, for the associated cable.

4.5 Maintenance

Under normal operation, the **A/B Power LED** and all the **Channel Fuse LEDs** are on. If all are off, check the power supply to MTA. If the **A/B Power LED** is off, check the power supply to the MTA. If the **Channel Fuse LED** is off, check the channel fuse and replace if necessary.

See Section 3, *Maintenance*, before performing any maintenance and observe all warnings.

4.6 8-Channel Analog Input Marshallled Termination Assembly

The figure below shows the basic parts of the 8-Channel Analog Input MTA.

Figure 4–1 8-Channel Analog Input Marshallled Termination Assembly (6ES7650-1AA51-2XX0 or 6ES7650-1AA50-2XX0)

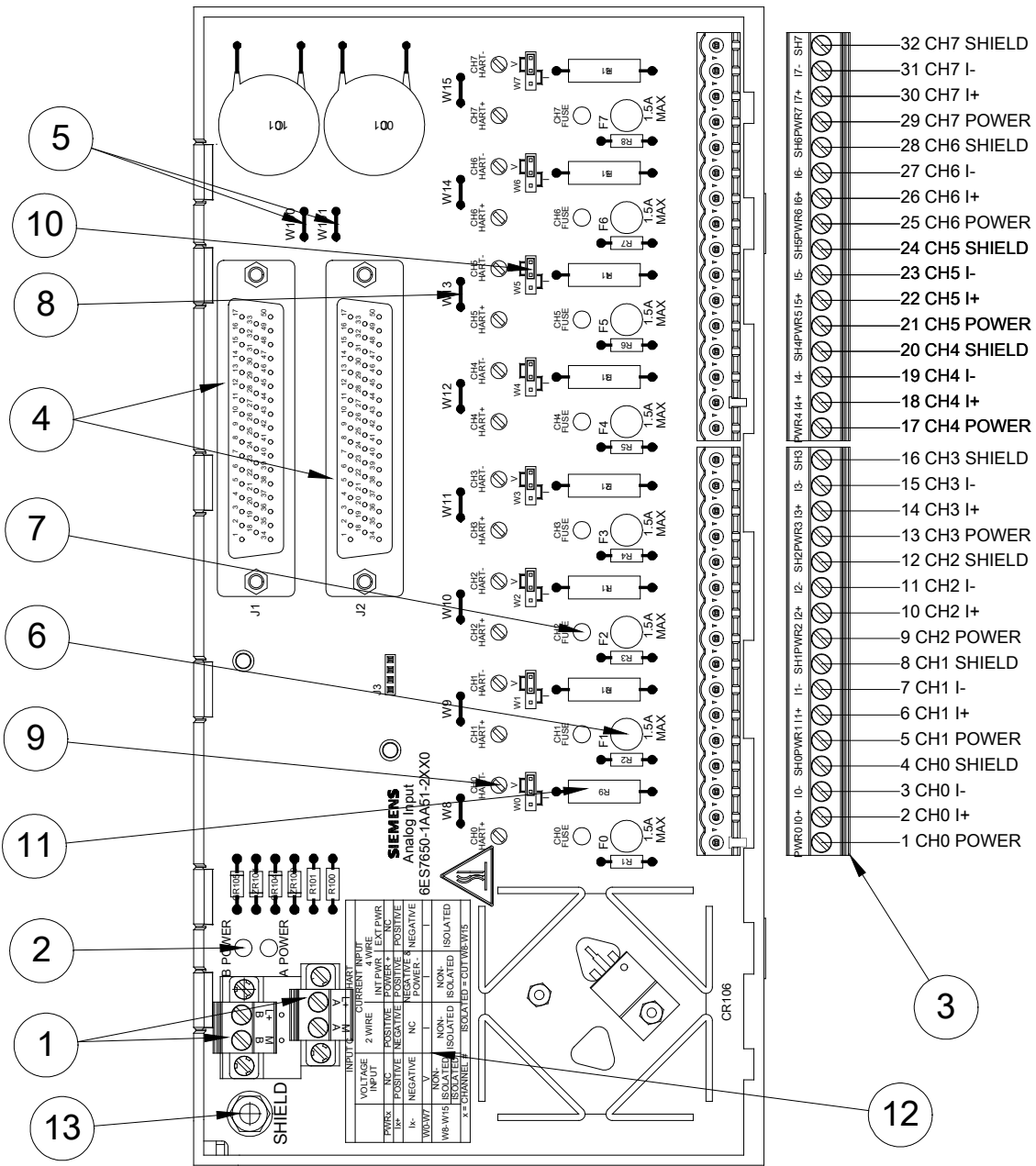

Key to numbered items in Figure 4-1:	
Item	Description
1	Input power connections
2	Input Power Indicators
3	Field Connections
4	I/O Module Connections (J1 & J2)
5	Shield disconnect jumper (W100 & W101)
6	Field power fuses
7	Field power indication (1 of 8)
8	Input Isolation Jumpers (W8 – W15)
9	HART connectivity
10	Input Mode Jumper (I – V)
11	250 Ω resistors (R9-R16)
12	Input Connection Chart
13	Shield Ground Stud for connecting to earth ground

4.7 Technical Specifications

Technical Specifications for 8-Channel Analog Input MTA (6ES7650-1AA51-2XX0 or 6ES7650-1AA50-2XX0)	
Dimensions - See Section 1, Figure 1.3, Long Version	
Mounting	
DIN Rail	35mm (deep top hat style)
Power Input	
Voltage Input for Single or Redundant Feed	21.6 to 28.8 VDC
Current Consumption (nominal ratings; all channels connected)	
Inrush	8.238 A maximum (Includes 8.16 A for transmitter inrush)
Normal	0.265 A maximum
Terminal Block Wire Sizes	TB100 & TB101
Wire Size – US	24 – 14 gauge AWG
Wire Size – Metric	0,205 – 2,08 mm sq.
Power Supply Specifications	See Module Specs
Fuse Ratings	
Individual channel – Normal	0.5 A Fast blow (Littelfuse P/N: 273.500) (Siemens Spare P/N: A5E01568880)
Individual channel – Optional	1.5 A Fast blow (Littelfuse P/N: 273 01.5) (Siemens Spare P/N: A5E01568886) Max total channel current: 8.16 Amps
Module	NA
Indicators	
Input Power	Green LED on when input power available
Module Power	NA
Channel Power	Green LED on when sensor power available
Field Terminal Block Wire Sizes TB1 – TB2	
Wire Size – US	24 – 14 gauge AWG
Wire Size – Metric	0,205 – 2,08 mm sq.
Environmental	
Ambient Temperature	-25C to +60C
Humidity	5% to 95% Non-condensing
Approvals	
MTA Agency Approvals	See Preface section, Approvals Table

Note

Fuses are available as spare parts from Siemens.

Fuse information can be found at:

<http://www.littelfuse.com>

<http://www.bussmann.com>

4.8 Module Restrictions

Restrictions for 8-Channel Analog Input MTA (6ES7650-1AA51-2XX0 or 6ES7650-1AA50-2XX0)	
I/O Module Restrictions	
MTA	None
SAI Module	None
Voltage	+/-5 V, 1 - 5 V, & +/-10 V
Current	0 – 20 mA, +/- 20 mA, & 4 – 20 mA
Module Accuracy	
Voltage Input (MTA I/V set to V)	See Module Specs
Current Input (MTA I/V set to I)	See Module Specs

4.9 Typical Transmitter Connection to Field Terminals

Figure 4–2 Analog Input Current Input Connection Examples (MTA I/V Jumper set to I)

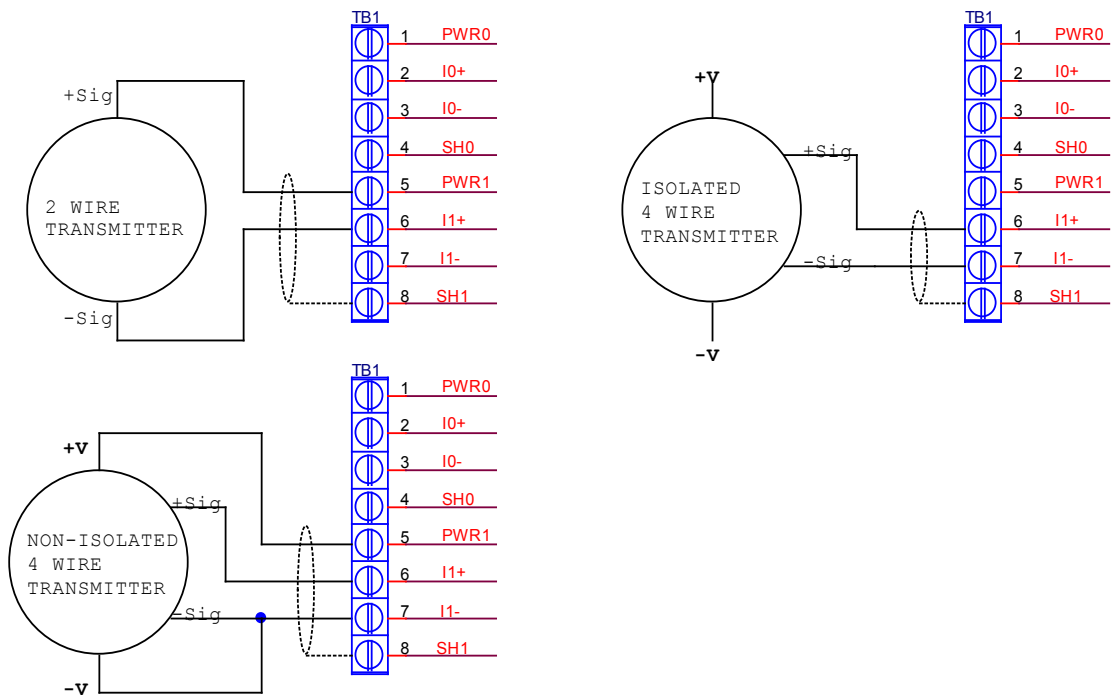
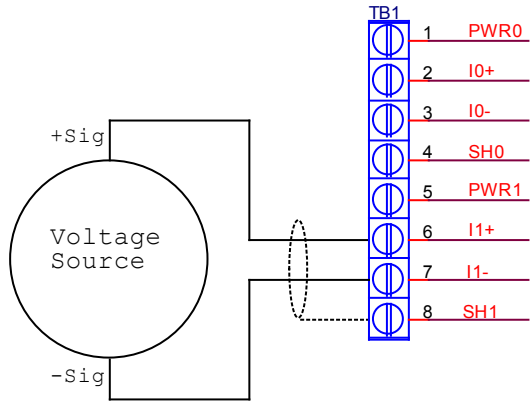

Figure 4-3 Analog Input Voltage Input Connection Example (MTA I/V Jumper set to V)



4.10 Hardware Configuration

Use the I – V jumpers to select voltage or current input signals.

Configure the AI8 module to match the input signal type.

See Figure 4–1, Item 8, for the location of the isolation jumper and Item 10, for the location of the I - V Jumper.

4.10.1 Addresses

Non-redundant Operation

The choice of the Input Address and Process Image are left to the user.

Redundant Operation

Process Image should be set to something other than the default. The choice of the Input Address is left to the user.

Figure 4–4 shows addresses and process image for a redundant configuration.

Figure 4–4 8-Channel Analog Input Hardware Configuration: Address Setup for Redundant Operation

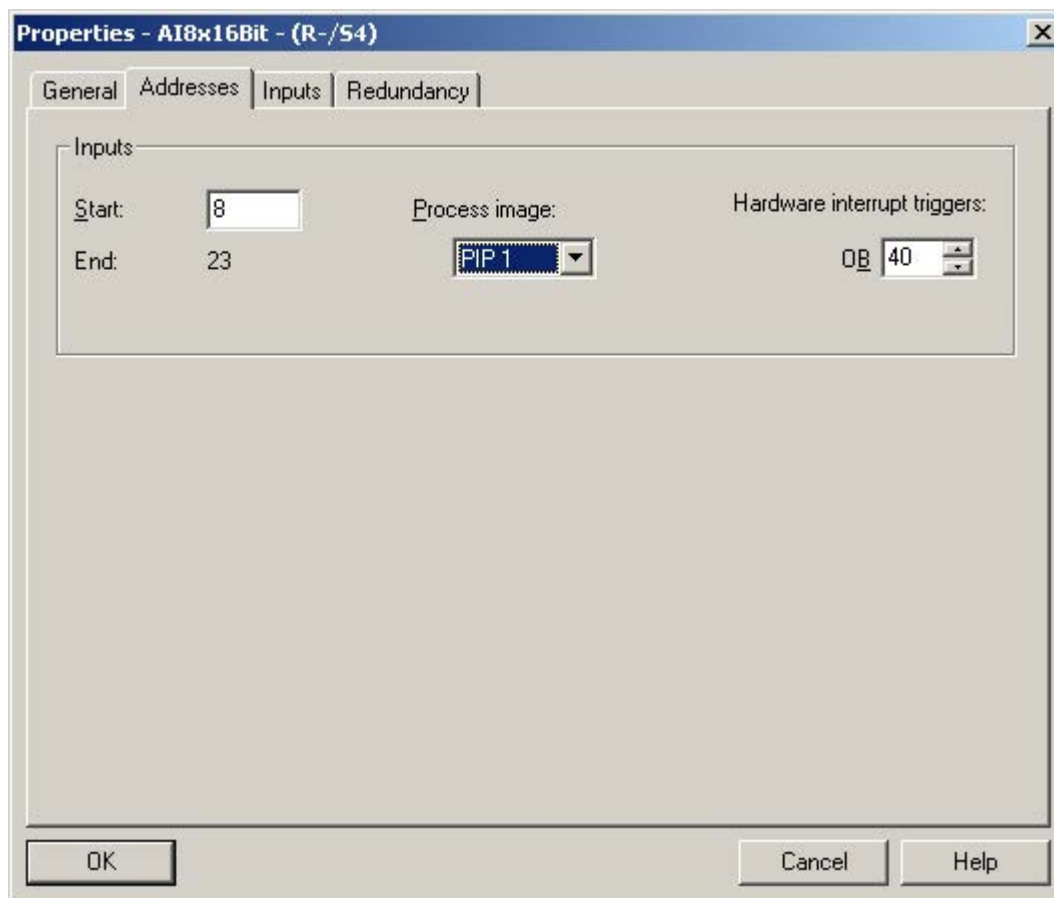

4.10.2 Inputs

Select appropriate module hardware configuration settings.

Select **Measuring Type** and **Measuring Range** settings to match the input signal connected to the channel inputs.

Measurement of signals less than 0 volts or 0 mA requires that the channel isolation jumper be cut.

Figure 4–5 shows the all the diagnostic boxes checked.

Figure 4–5 8-Channel Analog Input Hardware Configuration: Inputs Setup

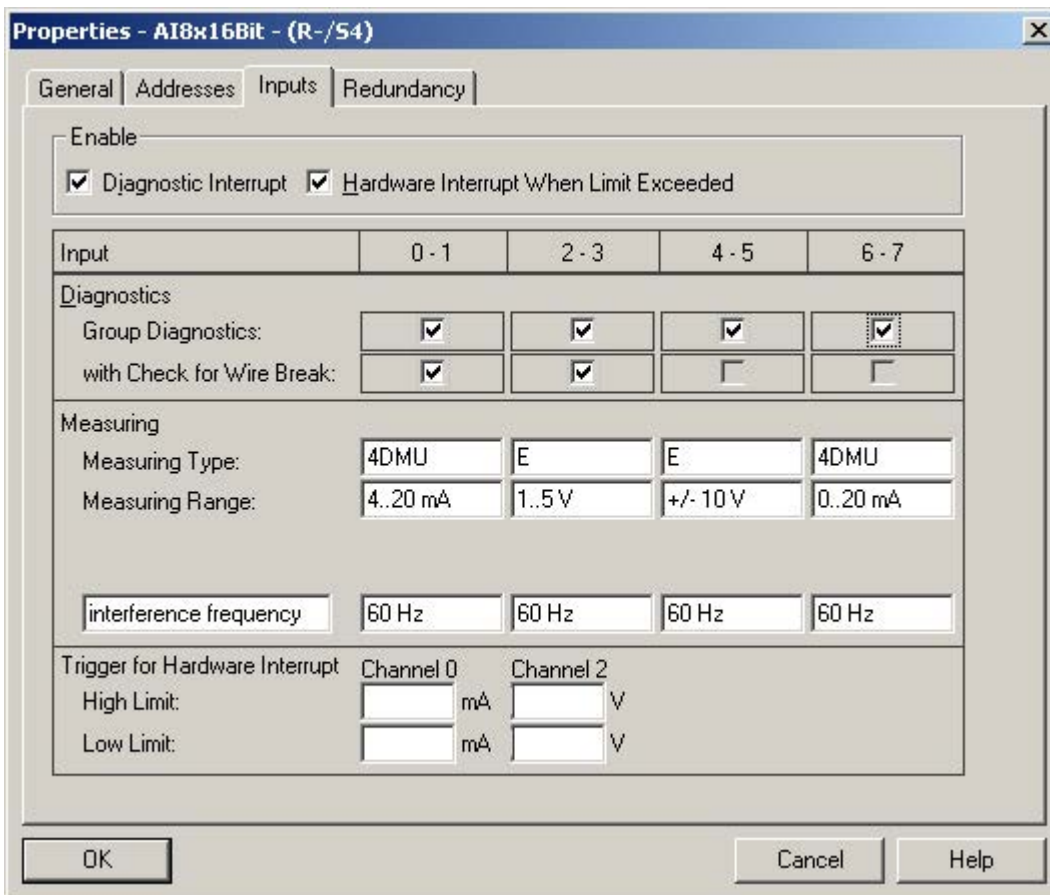

Note

- Use the AI8 MTA **I – V** jumpers to select voltage or current input signals.
- Configure the AI8 module to match the input signal type.
- See Figure 4–1, Item 10, for the location of the **I - V** Jumper.

4.10.3 Redundancy

Figure 4–6 shows the redundant configuration. For non-redundant operation, in the **Redundancy** box, select **None**.

All other parameters should be set to user preferences.

Figure 4–6 8-Channel Analog Input Hardware Configuration: Redundancy Selection

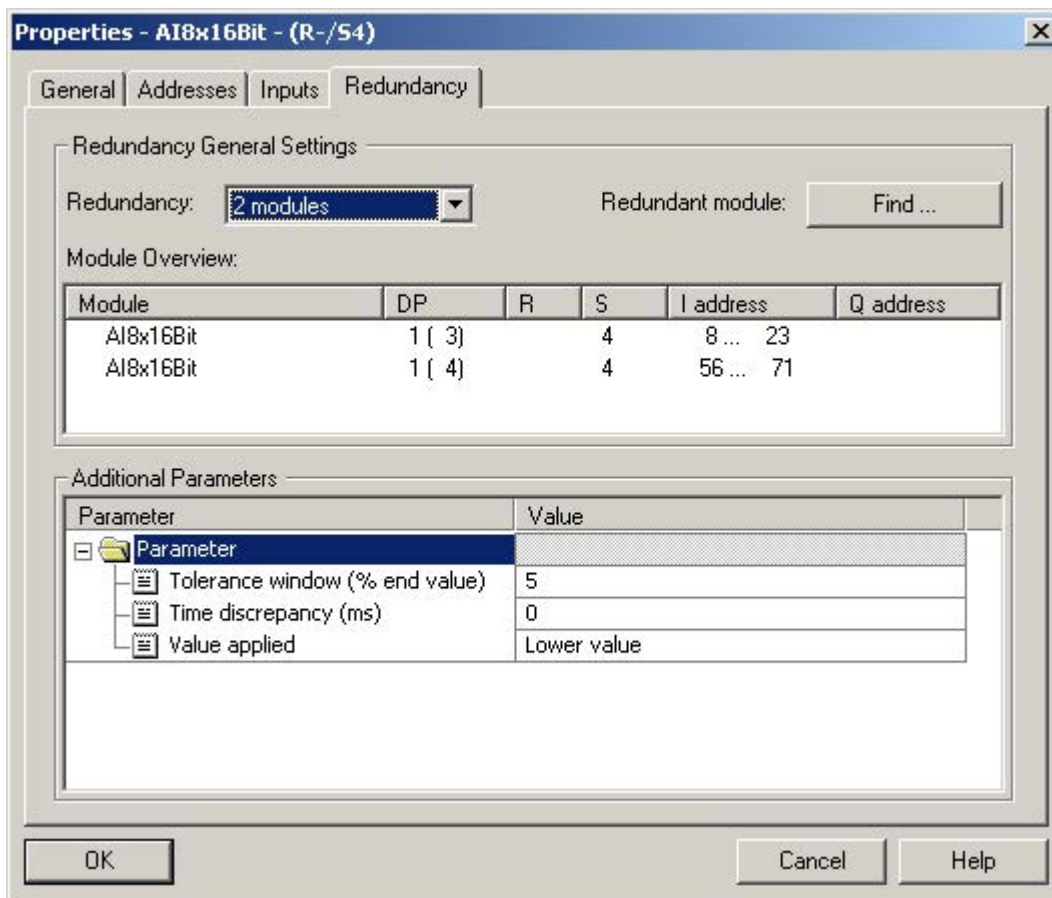

4.11 Technical Specifications for 8-Channel Analog Input Module (6ES7 331-7NF00-0AB0)

Note

For a complete functional description and the most current technical specifications for this module, refer to the manual *S7-300 Programmable Controller Module Specifications* (document number A5E00105505).

5 8-Channel Analog Input MTA

Part No. 6ES7650-1AA52-2XX0

5.1 Description

This section contains installation information and requirements for Siemens Marshalled Termination Assembly (MTA) (6ES7650-1AA52-2XX0) which connects to the Siemens ET 200M 8-Channel Analog Input Module (6ES7 331-7NF00-0AB0, E-Stand 5 or higher) or the Siemens ET 200M 8-Channel Analog Input Module (6ES7 331-7NF10-0AB0; E-Stand 8 or higher).

5.2 Features

This MTA has the following features:

- Redundant power connections
- LED indication of redundant power supply condition
- LED indication of reverse polarity
- LED indication of module power supply fuse status
- Power monitor output
- short circuit proofed 2-wire transducer supply per channel
- Dual connectors for redundant I/O Module operation
- Shield connections available for channel cabling
- Ground stud for connecting shield to earth ground
- Connectivity for HART Handheld Terminal (HHT) per channel
- Parameterization of current/ voltage and 2-wire/4-wire by jumper

5.3 Modification vs 8-Channel Analog Input MTA 6ES7650-1AA51-2XX0

- connects AI8x16bit 6ES7 331-7NF00-0AB0 and 6ES7 331-7NF10-0AB0
- electronically short circuit proofed 2-wire transducer supply
- no power supply support for 4-wire transducer
- Power Monitor System onboard
- one piece connectors
- short version housing

5.4 Operation

Power is supplied via two power connectors marked **L/A+**, **M/A**, and **L/B+**, **M/B**. Each has a circuitry to detect the presence of voltage over 15 VDC and turn on the LED indicator (green). The case of polarity reversal of the power supply is indicated by the LEDs illuminating red. The LEDs are marked **A POWER** and **B POWER**.

Incoming power from **A** and **B** is diode OR'd to provide the MTA power from either input source. The 6ES7331-7NF00-0AB0 module does not require any power compared to the 6ES7331-7NF10-0AB0 module. For this purpose the output from the diodes is sent to the I/O-Module power supply.

An onboard Power Monitor System (PMS) is used to provide an isolated dry contact when redundant power is supplied to MTAs. Only when power is supplied to both power inputs the output contacts **1** and **2** are closed. The Power Monitor System is designed to detect only the presence or absence of power. It is not designed to detect supply voltage which is outside the specification threshold.

The MTA has three types of jumpers for customer use:

- **1 – V** jumpers are a header and shunt type that determines the connection to the input signal.
- **2 – 4** jumpers are a header and shunt type that determines the connection to the input signal.
- Isolation jumpers **MODULE 1**, **MODULE 2** are wires that can be used to cut the shield connection between the MTA and the I/O Modules.

Field Terminals, Channel + (**Ix+**), Channel – (**Ix-**), Sensor power (**PWx**) and Shield (**SHx**), connect to the field devices. **PWx** is the +24 VDC power feed and the current is limited (max. 40mA) electronically on a channel by channel basis.

The channel inputs from the MTA connect to the I/O modules inputs via the connectors **Module1** and **Module2**. Redundant operation uses two modules with one each connected to **Module1** and **Module2**, while non-redundant systems have one module connected to either **Module1** or **Module2**.

5.5 Installation Requirements

See Section 2, *Installation*, before performing any installation and observe all warnings

Two interconnecting cable types (for Module 6ES7331-7NF00-0AB0: 6ES7922-3BD00-0BA0 (3m), 6ES7922-3BJ00-0BA0 (8m); for Module 6ES7331-7NF10-0AB0: 6ES7922-3BD00-0BB0 (3m), 6ES7922-3BJ00-0BB0 (8m)) , supporting eight analog input channels, connects the analog input termination assembly to the 8-channel analog input module (6ES7 331-7NF00-0AB0, E-Stand 5 or higher) or to the 8-channel analog input module (6ES7331-7NF10-0AB0). See Figure 5–1.

It may be necessary to modify the printed circuit board as follows:

- For channels measuring voltage, move the **I – V** jumper for that channel to the **V** side and the **2 – 4** jumper for that channel to **4** side.
- For channels measuring current, move the **I – V** jumper for that channel to the **I** side and the **2 – 4** jumper to **2** for using 2 wire transducer or **4** for using 4 wire transducer.
- For channels which are connected to a non isolated 4-wire transducer, set the **I – V** jumper to **I** and the **2 – 4** jumper to **2**. (see Figure 5–3)

Note

To disconnect the interconnecting cable shield from ground at the MTA only, cut and remove the shield disconnect jumpers, **Module1** and **Module2**, for the associated cable.

5.6 Maintenance

Under normal operation, the **A/B Power LED** and the fuse status LEDs, are on. If all are off, check the power supply to the MTA. If the module fuses status LEDs are off, check the fuses **Module1** and **Module2** of the MTA and replace them if necessary.

See Section 3, *Maintenance*, before performing any maintenance and observe all warnings.

5.7 8-Channel Analog Input Marshalled Termination Assembly

The figure below shows the basic parts of the 8-Channel Analog Input MTA.

Figure 5-1 8-Channel Analog Input Marshalled Termination Assembly (6ES7650-1AA52-2XX0)

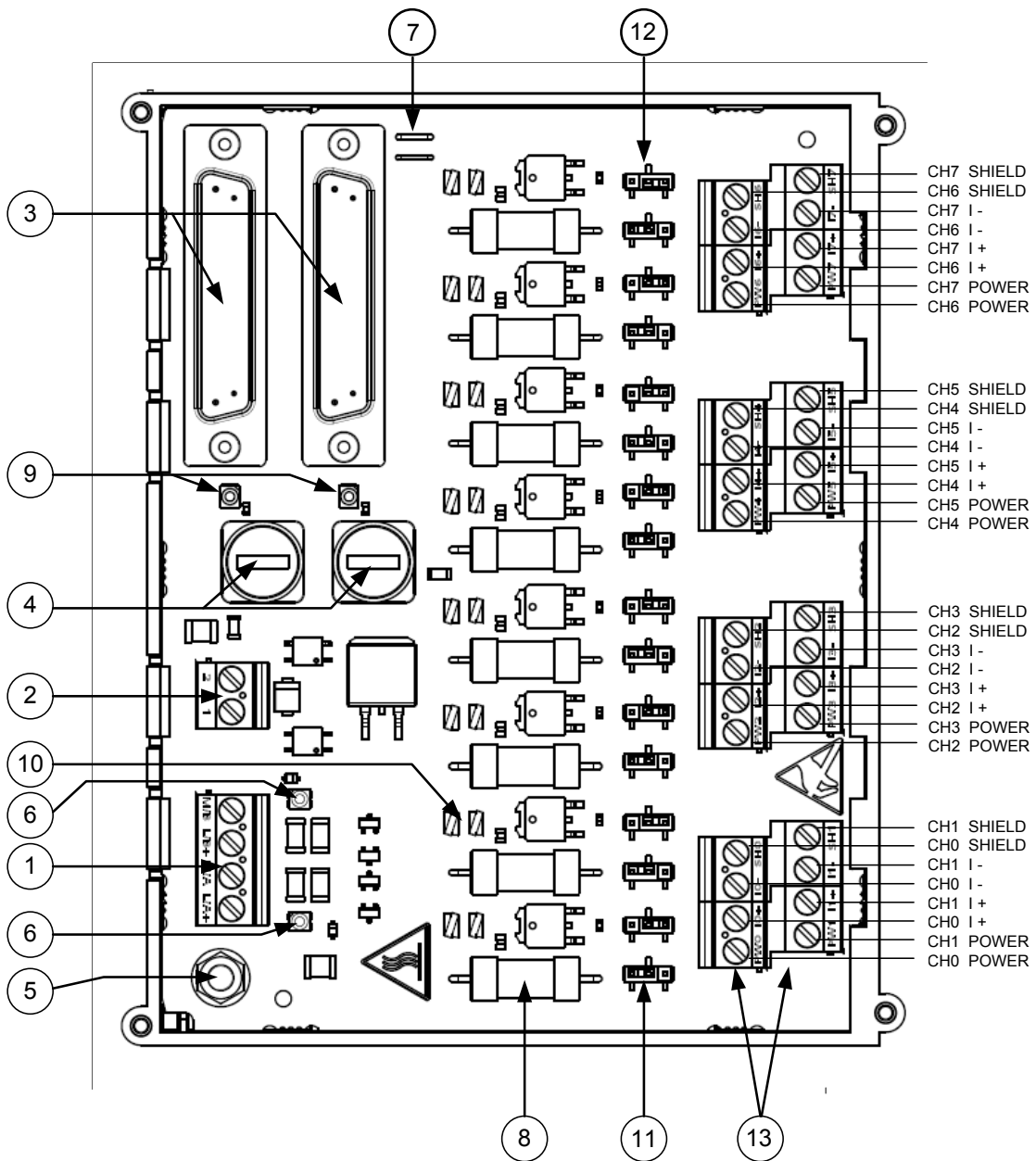

Key to numbered items in Figure 5-1:	
Item	Description
1	Input power connections (L/A+, M/A, L/B+, M/B)
2	Output Power Monitoring System (1, 2)
3	I/O Module Connections (MODULE1, MODULE2)
4	Module fuses (MODULE1, MODULE2)
5	Shield Ground Stud for connecting to earth ground (SHIELD)
6	Input Power Indicators (A POWER, B POWER)
7	Shield disconnect jumper (MODULE 1, MODULE 2)
8	250 Ω resistors
9	Module fuse indicators
10	HART connectivity (+, -)
11	Input mode jumper (I – V)
12	Transducer mode jumper (2 – 4)
13	Field connections

5.8 Technical Specifications

Technical Specifications for 8-Channel Analog Input MTA 6ES7650-1AA52-2XX0 in use with I/O modules 6ES7331-7NF00-0AB0 and cables 6ES7 392-3Bx00-0BA0	
Dimensions - See Section 1, Figure 1.3, Short Version	
Mounting	
DIN Rail	35mm (deep or shallow; with panel mounted DIN rail only deep)
Power Input	
Voltage Input for Single or Redundant Feed	21.6 to 28.8 VDC
Current Consumption (nominal ratings, all channels 20mA)	< 0.2 A
Power Dissipation (typical)	1 W
Permissible potential difference	
Between the channels	AC 35V / DC 50V
Fuse Ratings / Current Limiting	
Module	0.5 A (Bussmann P/N: GMA-0.5-R) (Siemens Spare P/N: A5E00755625)
Power output for 2-wire transducer supply	
Supply current for each channel	typ. 20 mA
Short circuit current	25 ... 42 mA
Load capability	> 750 Ω
Open loop voltage	L+
Short circuit protection	electronically; individual for each channel
Power Monitoring System - Optorelay Output Contact Ratings	
Threshold voltage	ca. 15 V
Maximum switched Voltage	30 V DC
Maximum switched Current	0.5 A resistive load; not short circuit proofed
Indicators	
Input Power	Green LED on when input power available, red LED on if power supply is reversed
Module Fuse OK	Green LED on when module power available
Field Terminals	
Wire Size – US	24 – 14 AWG
Wire Size – Metric	0,205 – 2,08 mm sq.
Environmental	
Ambient Temperature	-25C to +60C
Humidity	5% to 95% Non-condensing

Technical Specifications for 8-Channel Analog Input MTA 6ES7650-1AA52-2XX0 in use with I/O modules 6ES7331-7NF00-0AB0 and cables 6ES7 392-3Bx00-0BA0	
Module Accuracy	
<ul style="list-style-type: none"> Basic error limit (25°C) 	
voltage mode	± 0,05%
current mode	± 0,15%
<ul style="list-style-type: none"> Operational error limit (overall temperature range; U_{cm} = 0V) 	
voltage mode	± 0,1%
current mode	± 0,4%
<ul style="list-style-type: none"> Operational error limit (overall temperature range; U_{cm} = 50V) 	
voltage mode	± 0,7%
current mode	± 1,0%
Approvals	
MTA Agency Approvals	See Preface section, Approvals Table (in User's Manual)

Technical Specifications for 8-Channel Analog Input MTA 6ES7650-1AA52-2XX0 in use with I/O modules 6ES7331-7NF10-0AB0 and cables 6ES7 392-3Bx00-0BB0	
Dimensions - See Section 1, Figure 1.3, Short Version	
Mounting	
DIN Rail	35mm (deep or shallow; with panel mounted DIN rail only deep)
Power Input	
Voltage Input for Single or Redundant Feed	21.6 to 28.8 VDC
Current Consumption (nominal ratings; all channels 20mA)	< 0,5 A
Power Dissipation (typical)	1 W
Permissible potential difference	
Between the channels	AC 60V / DC 75V
Fuse Ratings / Current Limiting	
Module	0.5 A (Bussmann P/N: GMA-0.5-R) (Siemens Spare P/N: A5E00755625)
Power output for 2-wire transducer supply	
Supply current for each channel	typ. 20 mA
Short circuit current	25 ... 42 mA
Load capability	> 750 Ω
Open loop voltage	L+
Short circuit protection	electronically; individual for each channel
Power Monitoring System – Optorelay Output Contact Ratings	
Threshold voltage	ca. 15 V
Maximum switched Voltage	30 V DC
Maximum switched Current	0.5 A resistive load; not short circuit proofed
Indicators	
Input Power	Green LED on when input power available, red LED on if power supply is reversed

Technical Specifications for 8-Channel Analog Input MTA 6ES7650-1AA52-2XX0 in use with I/O modules 6ES7331-7NF10-0AB0 and cables 6ES7 392-3Bx00-0BB0	
Module Fuse OK	Green LED on when module power available
Field Terminals	
Wire Size – US	24 – 14 AWG
Wire Size – Metric	0,205 – 2,08 mm sq.
Environmental	
Ambient Temperature	-25C to +60C
Humidity	5% to 95% Non-condensing

Technical Specifications for 8-Channel Analog Input MTA 6ES7650-1AA52-2XX0 in use with I/O modules 6ES7331-7NF10-0AB0 and cables 6ES7 392-3Bx00-0BB0	
Module Accuracy	
<ul style="list-style-type: none"> Basic error limit (25°C) 	
voltage mode	± 0,05%
current mode	± 0,15%
<ul style="list-style-type: none"> Operational error limit (overall temperature range) 	
voltage mode	± 0,1%
current mode	± 0,2%
Approvals	
MTA Agency Approvals	See Preface section, Approvals Table (in User's Manual)

Note

Fuses are available as spare parts from Siemens.

Fuse information can be found at:

<http://www.bussmann.com>

5.9 Module Restrictions

Restrictions for 8-Channel Analog Input MTA (6ES7650-1AA52-2XX0)	
I/O Module Restrictions	
MTA	None
8AI Module	None
Voltage	+/-5 V, 1 - 5 V, +/-10 V
Current	0 – 20 mA, +/- 20 mA, 4 – 20 mA

5.10 Typical Transmitter Connection to Field Terminals

Figure 5-2 Analog Input Current Input Connection Examples (MTA I/V Jumper set to I and 2/4 Jumper set to 2 or 4 depending on transmitter type)

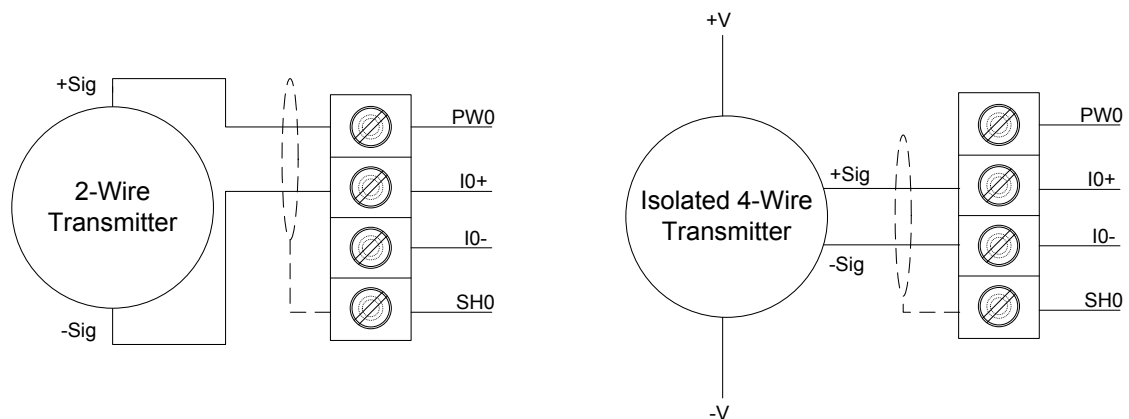
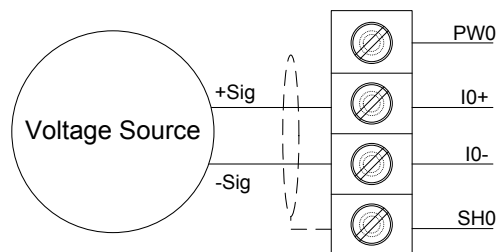

Figure 5-3 Analog Input Voltage Input Connection Example (MTA I/V Jumper set to V and 2/4 Jumper set to 4)



5.11 Hardware Configuration

Use the **I – V** jumpers to select voltage or current input signals and the **2 – 4** jumpers to select the transducer type. For voltage mode jumper **2 – 4** has to be set to **4**.

Configure the AI8 module to match the input signal type.

See Figure 4–1 5-1 for the location of the **I – V** jumper and Item 12, for the location of the **2 - 4** Jumper.

5.11.1 Addresses

Non-redundant Operation

The choice of the Input Address and Process Image are left to the user.

Redundant Operation

Process Image should be set to something other than the default. The choice of the Input Address is left to the user.

Figure 5-4 shows addresses and process image for a redundant configuration.

Figure 5-4 8-Channel Analog Input Hardware Configuration: Address Setup for Redundant Operation

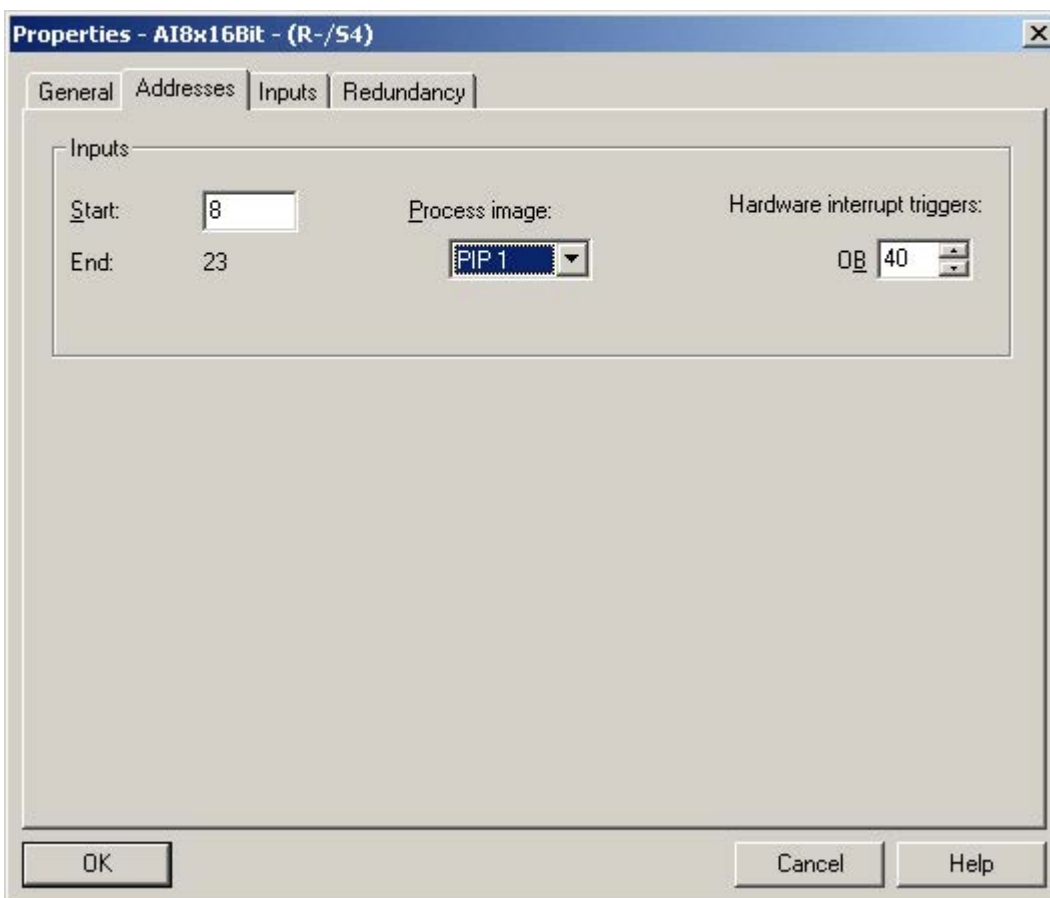

5.11.2 Inputs

Select appropriate module hardware configuration settings.

Select **Measuring Type** and **Measuring Range** settings to match the input signal connected to the channel inputs.

Figure 5-5 shows the all the diagnostic boxes checked.

Figure 5-5 8-Channel Analog Input Hardware Configuration: Inputs Setup

Input	0 - 1	2 - 3	4 - 5	6 - 7
Diagnostics				
Group Diagnostics:	<input checked="" type="checkbox"/>	<input checked="" type="checkbox"/>	<input checked="" type="checkbox"/>	<input checked="" type="checkbox"/>
with Check for Wire Break:	<input checked="" type="checkbox"/>	<input checked="" type="checkbox"/>	<input type="checkbox"/>	<input type="checkbox"/>
Measuring				
Measuring Type:	4DMU	E	E	4DMU
Measuring Range:	4..20 mA	1..5 V	+/- 10 V	0..20 mA
interference frequency	60 Hz	60 Hz	60 Hz	60 Hz
Trigger for Hardware Interrupt	Channel 0		Channel 2	
High Limit:	<input type="text"/> mA	<input type="text"/> V	<input type="text"/> mA	<input type="text"/> V
Low Limit:	<input type="text"/> mA	<input type="text"/> V	<input type="text"/> mA	<input type="text"/> V

Note

- Use the AI8 MTA **I – V** jumpers to select voltage or current input signals.
- Use the AI8 MTA **2 – 4** jumpers to select 2-wire or 4-wire mode.
- Configure the AI8 module to match the input signal type.
- See Figure 4–1, Item 11, for the location of the **I - V** Jumper and item 12 for the location if the **2 – 4** jumper.

5.11.3 Redundancy

Figure 4–65-6 shows the redundant configuration. For non-redundant operation, in the **Redundancy** box, select **None**.

All other parameters should be set to user preferences.

Figure 5-6 8-Channel Analog Input Hardware Configuration: Redundancy Selection

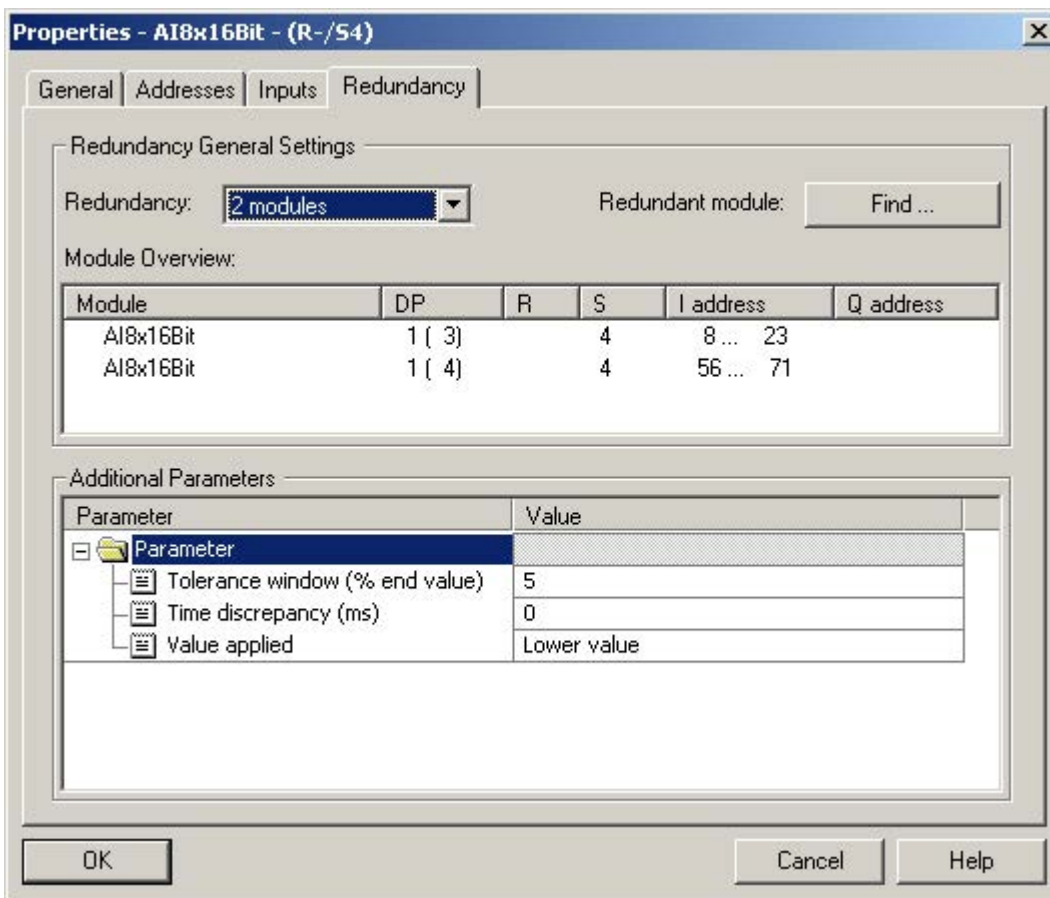

5.12 Technical Specifications for 8-Channel Analog Input Module (6ES7 331-7NF00-0AB0 / 6ES7331-7NF10-0AB0)

Note

For a complete functional description and the most current technical specifications for this module, refer to the manual *S7-300 Programmable Controller Module Specifications* (document number A5E00105505).

6 8-Channel Analog Output MTA

Part No. 6ES7650-1AB51-2XX0 or 6ES7650-1AB50-2XX0

6.1 Description

This section contains information and requirements to facilitate installation of Siemens Marshalled Termination Assembly (MTA) (6ES7650-1AB51-2XX0 or 6ES7650-1AB50-2XX0), designed to interface with the Siemens ET 200M 8-Channel Analog Output Module (6ES7 332-5HF00-0AB0, E-Stand 3 or higher).

Note: The only major difference between the two part numbers is the housing. The Anthracite Gray housing is the latest design. Functionality of both part numbers is the same.

Note

Drive capability for the analog output module is limited to less than 600 Ω .

6.2 Features

The following features have been incorporated into this MTA:

- Redundant power connections
- LED indication for each power supply
- Power monitor plug-in available (optional)
- Dual connectors for redundant I/O Module operation
- Per module power fusing
- Shield connections available for channel cabling
- Ground stud for connecting shield to earth ground
- Power input and field terminations are pluggable for easy maintenance
- Connectivity for HART Handheld Terminal (HHT) per channel

6.3 Operation

Power is supplied via the two removable power connectors which are retained by screws and marked **L+A, MA**, and **L+B, MB**. Each has circuitry to detect the presence of voltage over 15 VDC and turn on the LED indicator. The LEDs are marked **A POWER** and **B POWER**. There is also a connector (**J3**) for a Power Monitor board used to indicate the presence of both A and B power. See Section 19, *Power Monitor Board* (6ES7650-1BA02-0XX0).

Incoming power from **A** and **B** is diode OR'd, in CR106, to provide the MTA and the module power from either input source. The output from CR106 is sent to the I/O modules via the module fuses. Module Fuse 1 (**F100**) supplies the I/O module plugged into **J1** and Module Fuse 2 (**F101**) supplies power to the I/O module plugged into **J2**. The channels do not require power from the I/O power supply and therefore no channel power circuitry is required.

Field Terminals, Channel + (**CHx+**), Channel – (**CHx-**), and Shield (**SHx**), connect to the field devices. **CHx+** is the current output source and **CHx-** is the current output sink. The I/O module outputs from **J1** and **J2** are diode OR'd, via CR1-CR16, before connecting to **CHx+** of the Field terminals. Redundant operation uses two modules with one each connected to **J1** and **J2**, while non-redundant systems have one module connected to either **J1** or **J2**.

The field termination connector is removable for ease of wiring maintenance and is retained by friction.

6.4 Installation Requirements

See Section 2, *Installation*, before performing any installation and observe all warnings

A common interconnecting cable (6ES7922-3BD00-0AS0 or 6ES7922-3BJ00-0AS0), supporting eight analog output channels, interconnects the analog output termination assembly to the 8-channel analog output module (6ES7 332-5HF00-0AB0, E-Stand 3 or higher). See Figure 2-11.

It may be necessary to modify the printed circuit board as follows:

To separate channel input low from power supply common, cut and remove the jumper **W200**.

Note

To disconnect the interconnecting cable shield from ground at the MTA only, cut and remove the shield disconnect jumper, **W100** and **W101**, for the associated cable.

6.5 Maintenance

See Section 3, *Maintenance*, before performing any maintenance and observe all warnings

Under normal operation, the **A/B Power LED** and **Module 1/2 Fuse LED** are on. If both are off, check the power supply to MTA. If the **A/B Power LED** is off, check the power supply to the MTA. If **Module 1/2 Fuse LED** is off, check the module fuse and replace if necessary.

6.6 8-Channel Analog Output Marshallled Termination Assembly

Figure 6–1 below shows the basic parts of the 8-Channel Analog Output MTA.

Figure 6–1 8-Channel Analog Output Marshallled Termination Assembly

(6ES7650-1AB51-2XX0 or 6ES7650-1AB50-2XX0)

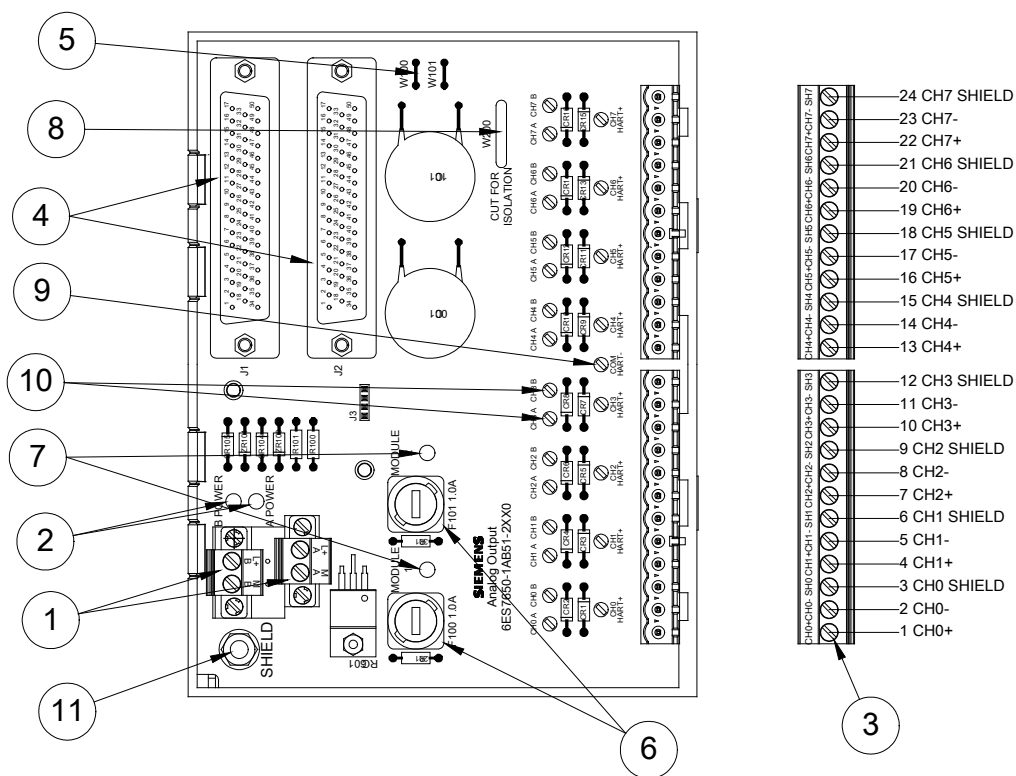

Key to numbered items in Figure 6–1:	
Item	Description
1	Input power connections
2	Input power indicators
3	Field wiring connections
4	I/O module connections (J1 & J2)
5	Shield disconnect jumper (W100 & W101)
6	Module power fuses
7	Module power indicators
8	Output isolation jumper (W200)
9	Hart connectivity (1 of 8)
10	I/O Module Output Test Points (2 of 16)
11	Shield Ground Stud for connecting to earth ground

6.7 Technical Specifications

Technical Specifications for 8-Channel Analog Output MTA (6ES7650-1AB51-2XX0 or 6ES7650-1AB50-2XX0)	
Dimensions - See Section 1, Figure 1.3, Short Version	
Mounting	
DIN Rail	35mm (deep top hat style)
Power Input	
Voltage Input for Single or Redundant Feed	21.6 to 28.8 VDC
Current Consumption (nominal ratings; all channels connected)	0.870 A Maximum
Power Dissipation (typical)	1 W
Terminal Block Wire Sizes	TB100 & TB101
Wire Size – US	24 – 14 gauge AWG
Wire Size – Metric	0,205 – 2,08 mm sq.
Power Supply Specifications	See Module Specs
Fuse Ratings	
Individual channel	NA
Module Power	1.0A (Bussmann P/N: GMA-1.0A) (Siemens Spare P/N: A5E01568882)
Indicators	
Input Power	Green LED on when input power available
Module Power	Green LED on when module power available
Channel Power	NA
Field Terminal Block Wire Sizes TB1 – TB2	
Wire Size – US	24 – 14 gauge AWG
Wire Size – Metric	0,205 – 2,08 mm sq.
Environmental	
Ambient Temperature	-25C to +60C
Humidity	5% to 95% Non-condensing
Approvals	
MTA Agency Approvals	See Preface section, Approvals Table

Note

Fuses are available as spare parts from Siemens.

Fuse information can be found at:

<http://www.bussmann.com>

6.8 Module Restrictions

Restrictions for 8-Channel Analog Output MTA (6ES7650-1AB51-2XX0 or 6ES7650-1AB50-2XX0)	
I/O Module Restrictions	
MTA Design	There is no Channel to Channel Isolation
MTA Design	Series diodes lower the output compliance load to less than 600 Ω
MTA Design	Short Circuit to M not detected
MTA Design	SAO must be configured for Current Mode
MTA Design	Output Range: only 4-20mA & 0-20mA ¹
Module Accuracy	
Current Output	See Module Specs

6.9 Typical Load Connection to Field Terminals

Figure 6–2 Connecting an Analog Output to Field Terminals

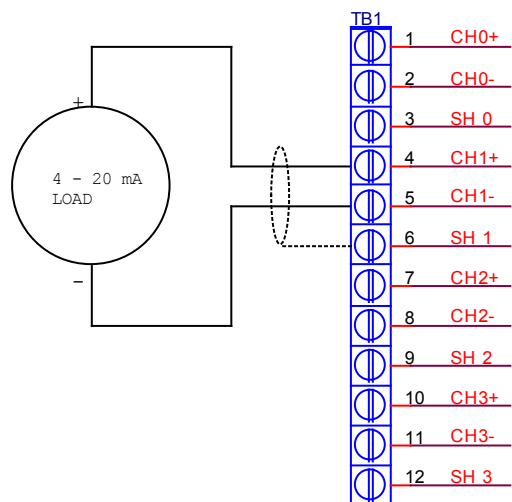

¹ Minimum 0, 22 mA cutoff current

6.10 Hardware Configuration

The Standard Analog Output MTA has no jumpers that affect the Module Hardware Configuration; however, the MTA design restricts the Module output to the current mode only.

Note

Redundant Operation. If a redundant Analog Output Module loses power (F10x opens) or is removed from service, then the output current will drop to 50% of its value for several controller cycles.

6.10.1 Addresses

Non-redundant Operation

The choice of the Input Address and Process Image are left to the user.

Redundant Operation

Process Image should be set to something other than the default. The choice of the Input Address is left to the user.

Figure 6–3 shows an analog input configured for redundant operation.

Figure 6–3 8-Channel Analog Output Hardware Configuration: Address Setup for Redundant Operation

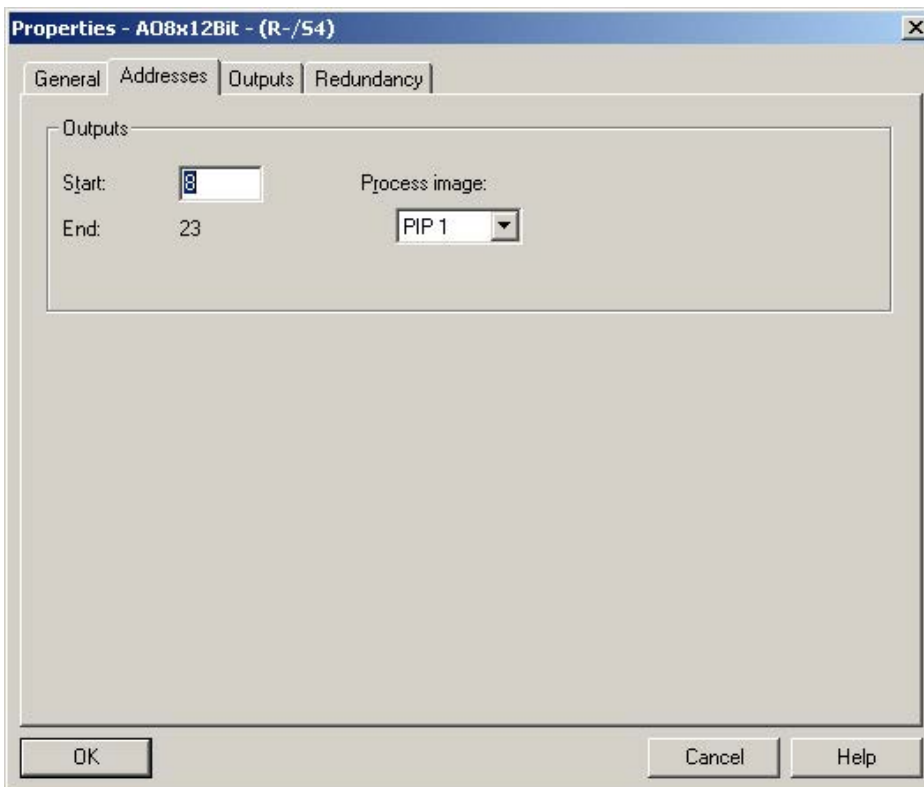

6.10.2 Outputs

For normal operation set **Type of Output** to current (I). The +/- 20 mA output range is not possible due to the MTA Design. All other Module hardware configuration choices under the **Outputs** tab are left to the user.

Figure 6–4 shows the **Type of Output** set to I and all the diagnostic options are checked.

Figure 6–4 8-Channel Analog Output Hardware Configuration: Outputs set for Current Mode operation

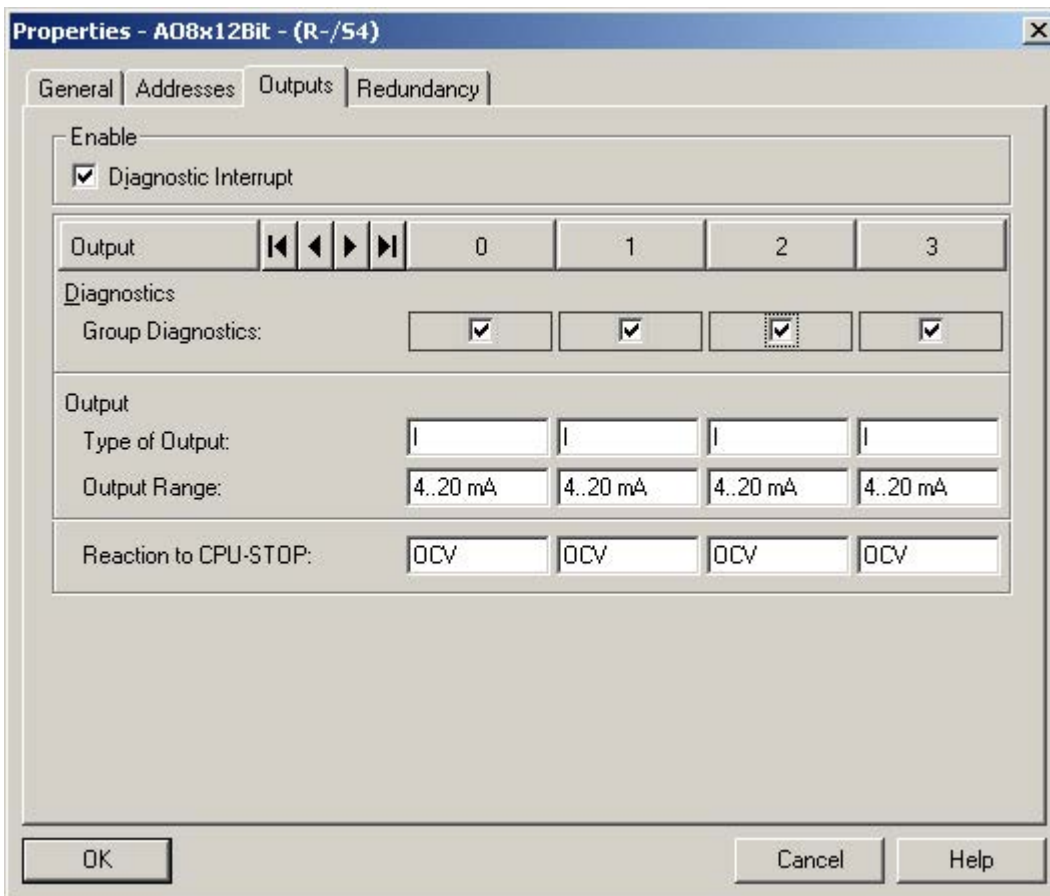

6.10.3 Redundancy

Figure 6–5 shows redundant configuration. For non-redundant operation the value of the **Redundancy** field should be **None**.

All other parameters should be set to user preferences.

Figure 6–5 8-Channel Analog Output Hardware Configuration: Redundancy Selection

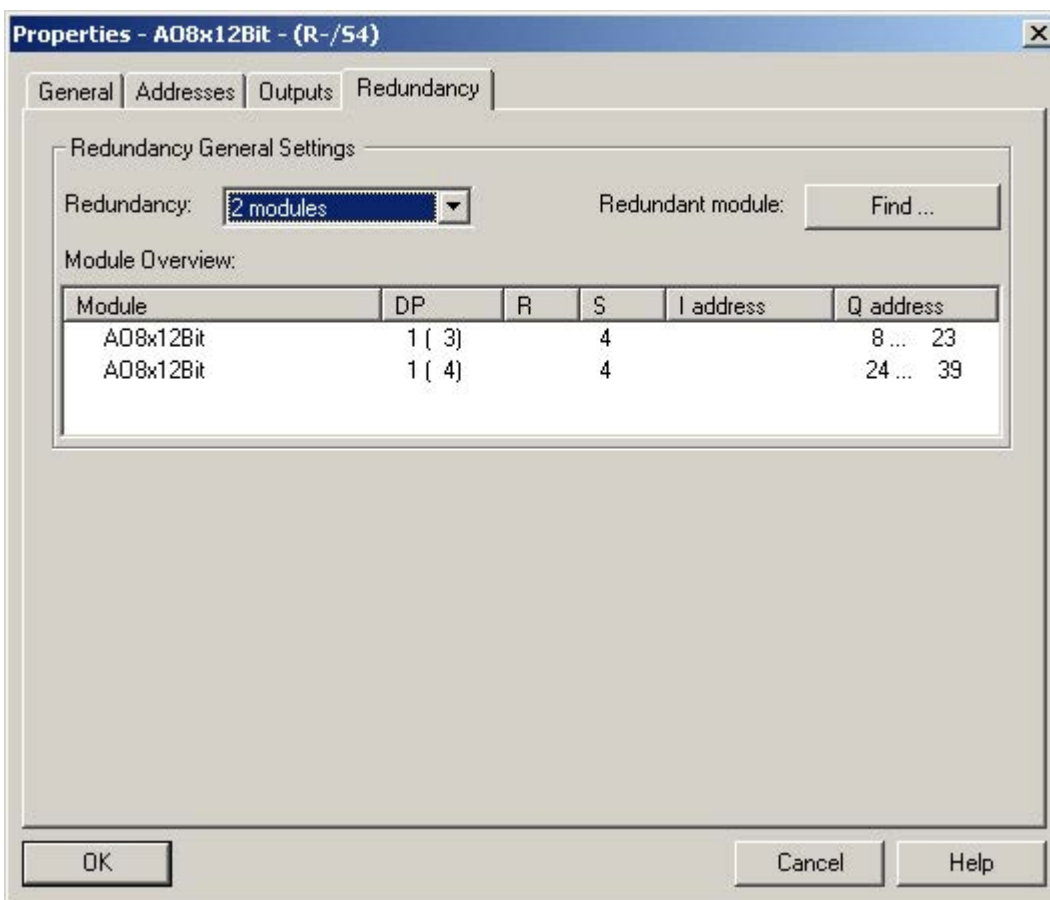

6.11 Technical Specifications for 8-Channel Analog Output Module (6ES7 332-5HF00-0AB0)

Note

For a complete functional description and the most current technical specifications for this module, refer to the manual *S7-300 Programmable Controller Module Specifications* (document number A5E00105505).

7 8-Channel RTD Input MTA

Part No. 6ES7650-1AG51-2XX0 or 6ES7650-1AG50-2XX0

7.1 Description

This section contains information and requirements to facilitate installation of Siemens Marshalled Termination Assembly (MTA) (6ES7650-1AG51-2XX0 or 6ES7650-1AG50-2XX0), designed to interface with the Siemens ET 200M 8-channel RTD Input Module (6ES7 331-7PF00-0AB0, E-Stand 8 or higher, & 6ES7 331-7PF01-0AB0).

Note: The only major difference between the two part numbers is the housing. The Anthracite Gray housing is the latest design. Functionality of both part numbers is the same.

7.2 Features

The following features have been incorporated into this MTA:

- LED indication of power supply condition
- Module power fusing
- Shield connections available for channel cabling
- Ground stud for connecting shield to earth ground
- Power input terminations are pluggable for easy maintenance

7.3 Operation

Power is supplied via the removable power connector that is retained by screws and marked **L+**, **M**. The **Module 1** LED indicates the presence of voltage and **F100** supplies power to the module connected to **J1**. The Power Monitor board option is not available on this MTA.

Incoming power is sent to the module via the power fuse.

Field Terminals, **Mx+**, **Mx-**, **Ix+**, **Ix-** and **SHx** connect to the field devices. The four field connections allow 4-wire, 3-wire, and 2-wire RTDs to be used with **Mx+** and **Mx-**, the measurement connections, and **Ix+** and **Ix-**, the current conducting connections. The **SHx** is the field cable shield connection. The field termination connections are not removable so that measurement errors can be reduced.

The four channel connections connect to the I/O module input via **J1**.

7.4 Installation Requirements

See Section 2, *Installation*, before performing any installation and observe all warnings

A common interconnecting cable (6ES7922-3BD00-0AS0 or 6ES7922-3BJ00-0AS0), supporting eight RTD input channels, interconnects the RTD input termination assembly to the 8-channel RTD input module (6ES7 331-7PF00-0AB0, E-Stand 8 or higher & 6ES7 331-7PF01-0AB0). See Figure 2-16.

Note

To disconnect the interconnecting cable shield from ground at the MTA only, cut and remove the shield disconnect jumper, **W100**.

7.5 Maintenance

See Section 3, *Maintenance*, before performing any maintenance and observe all warnings

Under normal operation, the I/O Power LED is on. If it is off, check the I/O Module Fuse and the power supply to the MTA.

7.6 8-Channel, RTD Input Marshalled Termination Assembly

Figure 7–1 shows the basic parts of the 8-Channel RTD Input MTA.

Figure 7–1 8-Channel RTD Input Marshalled Termination Assembly

(6ES7650-1AG51-2XX0 or 6ES7650-1AG50-2XX0)

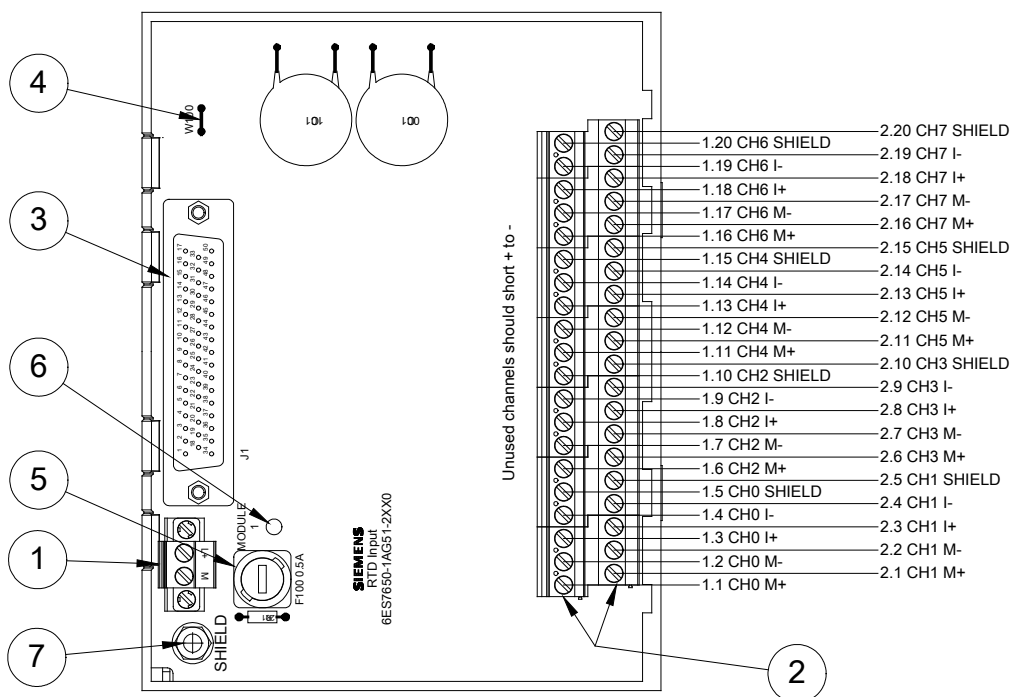

Key to numbered items in Figure 7–1:	
Item	Description
1	Input power connection
2	Field wiring connections
3	I/O Module connection
4	Shield disconnect jumper (W100)
5	I/O module power fuse
6	I/O module power indicator
7	Shield Ground Stud for connecting to earth ground

7.7 Technical Specifications

Technical Specifications for 8-Channel RTD Input MTA (6ES7650-1AG51-2XX0 or 6ES7650-1AG50-2XX0)	
Dimensions - See Section 1, Figure 1.3, Short Version	
Mounting	
DIN Rail	35mm (deep top hat style)
Power Input	
Voltage Input for Single Feed	21.6 to 28.8 VDC
Current Consumption (nominal ratings; all channels connected)	0.243 A maximum
Power Dissipation (typical)	1 W
Terminal Block Wire Sizes	TB100
Wire Size – US	24 – 14 gauge AWG
Wire Size – Metric	0,205 – 2,08 mm sq.
Power Supply Specifications	See Module Specs
Fuse Ratings	
Individual channel	NA
Module Power	0.5 A (Bussmann P/N: GMA-0.5A) (Siemens Spare P/N: A5E01568885)
Indicators	
Input Power	NA
Module Power	Green LED on when input power available
Channel Power	NA
Field Terminal Block Wire Sizes TB1 – TB2	
Wire Size – US	24 – 14 gauge AWG
Wire Size – Metric	0,205 – 2,08 mm sq.
Environmental	
Ambient Temperature	-25C to +60C
Humidity	5% to 95% Non-condensing
Approvals	
MTA Agency Approvals	See Preface section, Approvals Table

Note

Fuses are available as spare parts from Siemens.

Fuse information can be found at:

<http://www.bussmann.com>

7.8 Module Restrictions

Restrictions for 8-Channel RTD Input MTA (6ES7650-1AG51-2XX0 or 6ES7650-1AG50-2XX0)	
I/O Module Restrictions	
MTA Design	None
Module Accuracy	
RTD Inputs	See Module Specs

7.9 Typical R & RTD Connection to Field Terminals

Note

- When connecting an RTD in 2-wire Mode there will be no resistance error correction of the field wiring.
- The 3 wire connection method produces a constant offset. The temperature reading for a Platinum 100Ω RTD will read under by about 1°C for the 3m cable and 3°C for the 8m cable."
- For optimum accuracy 4 wire connections are recommended..

Figure 7–2 R & RTD Connection to Field Terminals

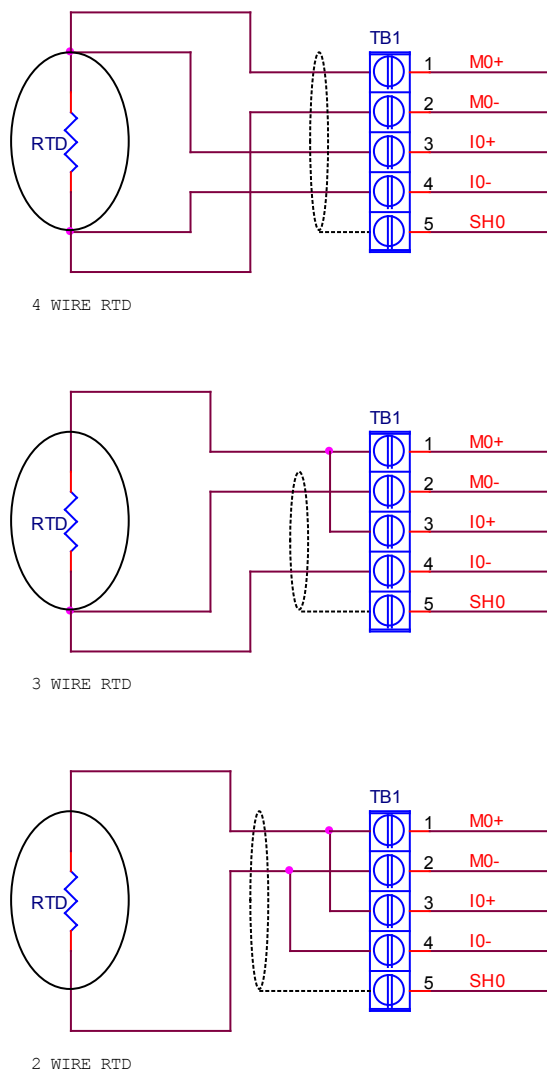

7.10 Hardware Configuration

Neither the 8-Channel RTD Module nor the MTA supports redundant operation

7.10.1 Addresses

Figure 7–3 shows Input address and process image set to a user's preferences.

Figure 7–3 8-Channel RTD Input Hardware Configuration: Address Setup

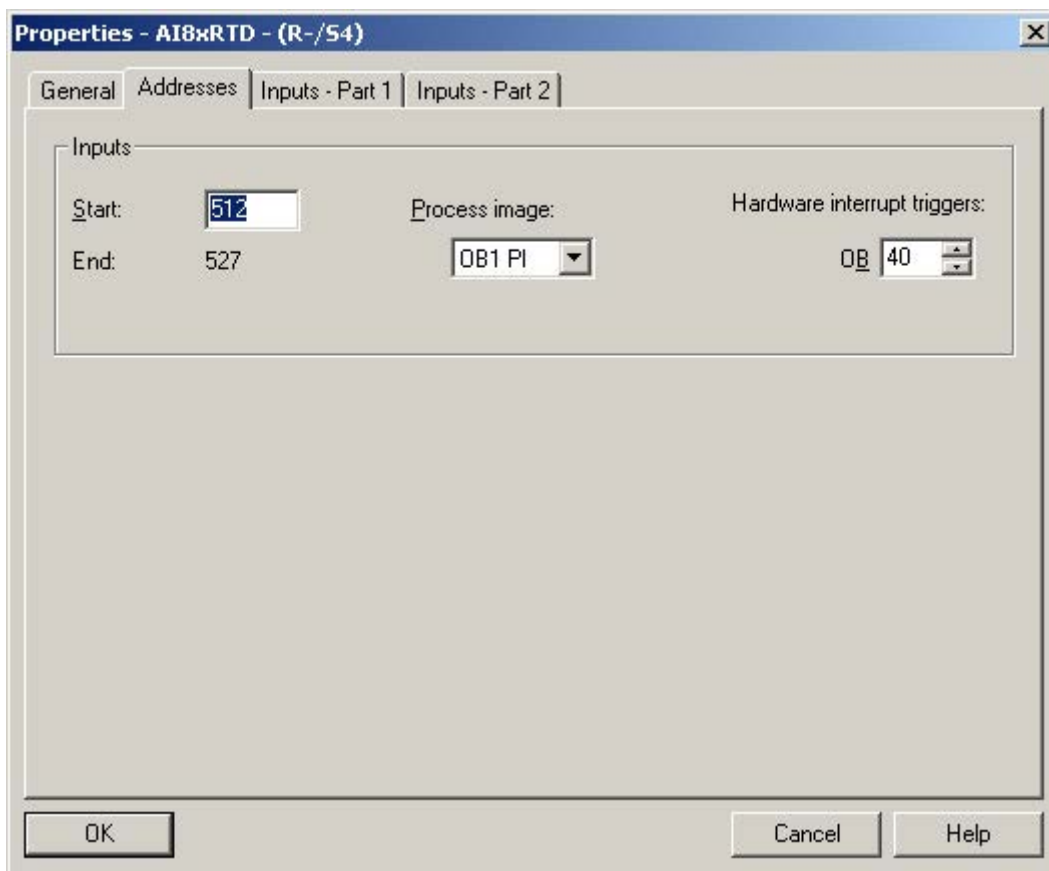

7.10.2 Inputs – Part 1

Input parameters should be set to the user preferences that are consistent with the input device being used.

Figure 7–4 shows some of the various configuration options for the Interrupts, Diagnostics, and Measuring parameters.

Figure 7–4 8-Channel RTD Input Hardware Configuration: Inputs - Part 1 Parameters

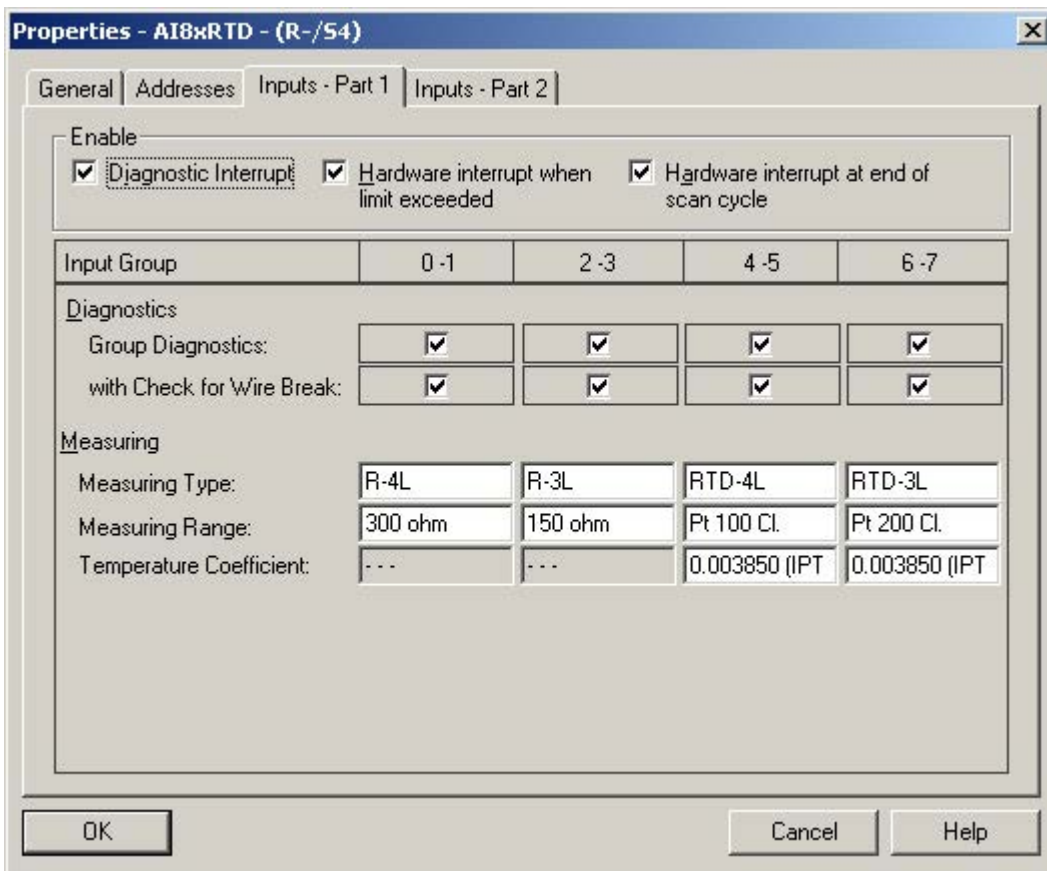

7.10.3 Inputs – Part 2

Input parameters should be set to the user preferences that are consistent with the input device being used.

Figure 7–5 shows **Temperature Unit** set to **degrees Celsius** but **degrees Fahrenheit** is also possible. All settings should be set to user preferences.

Figure 7–5 8-Channel RTD Input Hardware Configuration: Inputs - Part 2 Parameters

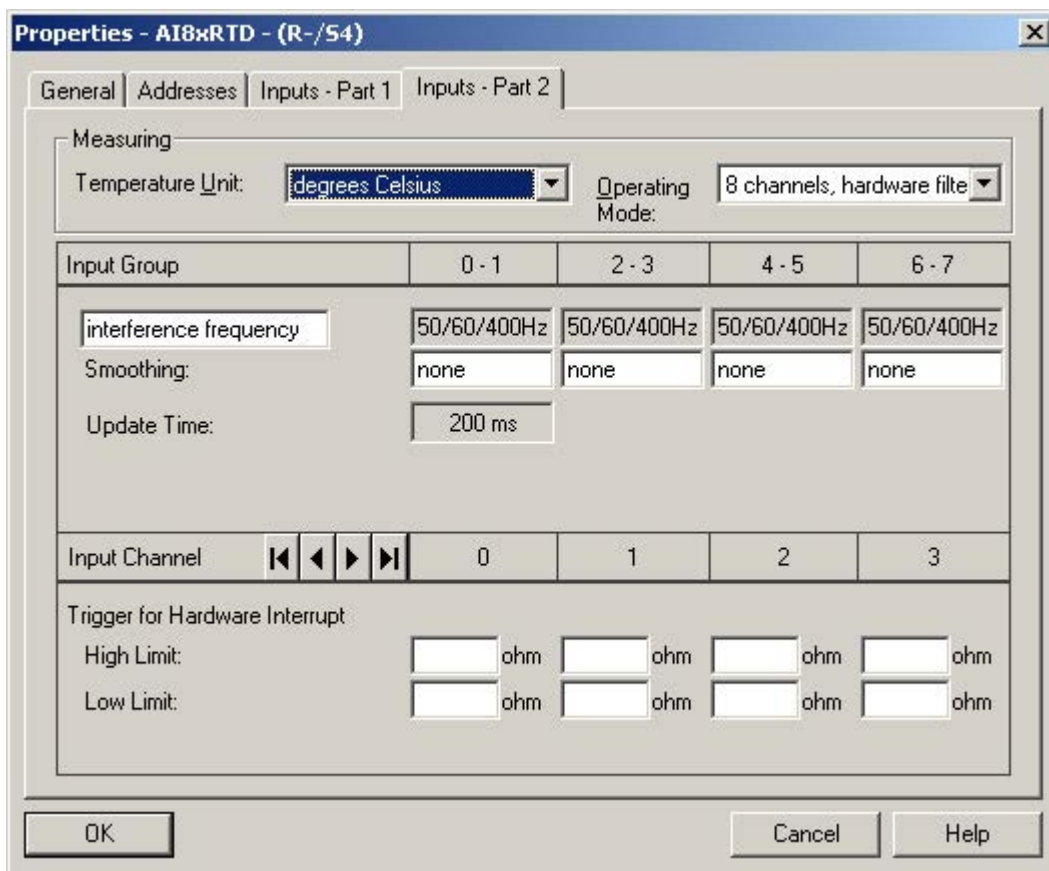

7.11 Technical Specifications for 8-Channel RTD Input Module (6ES7 331-7PF00-0AB0 & 6ES7 331-7PF01-0AB0)

Note

For a complete functional description and the most current technical specifications for this module, refer to the manual *S7-300 Programmable Controller Module Specifications* (document number A5E00105505).

8 8-Channel TC Input MTA

Part No. 6ES7650-1AF51-2XX0 or 6ES7650-1AF50-2XX0

8.1 Description

This section contains information and requirements to facilitate installation of Siemens Marshalled Termination Assembly (MTA) (6ES7650-1AF51-2XX0 or 6ES7650-1AF50-2XX0), designed to interface with the Siemens ET 200M 8-Channel TC Input Module (6ES7 331-7PF10-0AB0, E-Stand 4 or higher, & 6ES7 331-7PF11-0AB0).

Note: The only major difference between the two part numbers is the housing. The Anthracite Gray housing is the latest design. Functionality of both part numbers is the same.

8.2 Features

The following features have been incorporated into this MTA:

- Built in Reference Junction Sensor
- LED indication of power supply condition
- Module power fusing
- Shield connections available for channel cabling
- Ground stud for connecting shield to earth ground
- Power input terminations are pluggable for easy maintenance

8.3 Operation

Power is supplied via the removable power connector that is retained by screws and marked **L+**, **M**. The **Module 1** LED indicates the presence of voltage and **F100** supplies power to the module connected to **J1**. The Power Monitor board option is not available on this MTA.

Incoming power is sent to the module via the power fuse.

Field Terminals, **TCx+**, **TCx-**, and **SHx** connect to the field devices. The **TCx+** and **TCx-** field connections allow many types of thermocouples to be used with this MTA. The **SHx** is the field cable shield connection. The field termination connections are not removable so that measurement errors can be reduced.

The channel connections connect to the I/O module input via **J1**.

The MTA also contains an RTD for use as a reference junction sensor. It is thermally coupled to the field terminals and is used by the Module for reference.

8.4 Installation Requirements

See Section 2, *Installation*, before performing any installation and observe all warnings

A common interconnecting cable (6ES7922-3BD00-0AS0 or 6ES7922-3BJ00-0AS0), supporting eight Thermocouple input channels, interconnects the Thermocouple input termination assembly to the 8-channel Thermocouple input module (6ES7 331-7PF10-0AB0, E-Stand 4 or higher & 6ES7 331-7PF11-0AB0). See Figure 8–1.

Note

To disconnect the interconnecting cable shield from ground at the MTA only, cut and remove the shield disconnect jumper, **W100**.

8.5 Maintenance

See Section 3, *Maintenance*, before performing any maintenance and observe all warnings

Under normal operation, the I/O Power LED is on. If it is off, check the I/O Module Fuse and the power supply to the MTA.

8.6 8-Channel TC Input Marshallled Termination Assembly

Figure 8–1 8-Channel TC Input Marshallled Termination Assembly

(6ES7650-1AF51-2XX0 or 6ES7650-1AF50-2XX0)

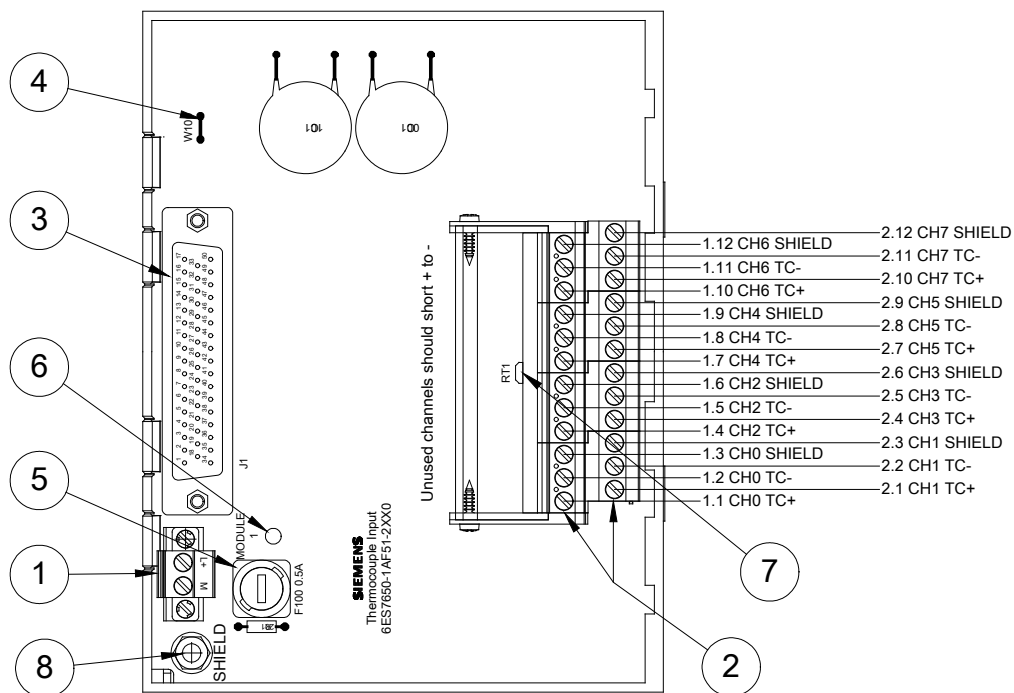

Key to numbered items in Figure 8–1	
Item	Description
1	Input power connection
2	Field wiring connections
3	I/O Module connection
4	Shield disconnect jumper (W100)
5	I/O module power fuse
6	I/O module power indicator
7	Reference Junction Sensor (PT100)
8	Shield Ground Stud for connecting to earth ground

8.7 Technical Specifications

Technical Specifications for 8-Channel TC Input MTA (6ES7650-1AF51-2XX0 or 6ES7650-1AF50-2XX0)	
Dimensions - See Section 1, Figure 1.3, Short Version	
Mounting	
Din Rail	35mm (deep top hat style)
Power Input	
Voltage Input for Single Feed	21.6 to 28.8 VDC
Current Consumption (nominal ratings; all channels connected)	0.243 A maximum
Power Dissipation (typical)	1 W
Terminal Block Wire Sizes	TB100
Wire Size – US	24 – 14 gauge AWG
Wire Size – Metric	0,205 – 2,08 mm sq.
Power Supply Specifications	See Module Specs
Fuse Ratings	
Individual channel	NA
Module Power	0.5 A (Bussmann P/N: GMA-0.5A) (Siemens Spare P/N: A5E01568885)
Indicators	
Input Power	NA
Module Power	Green LED on when input power available
Channel Power	NA
Field Terminal Block Wire Sizes TB1 – TB2	
Wire Size – US	24 – 14 gauge AWG
Wire Size – Metric	0,205 – 2,08 mm sq.
Environmental	
Ambient Temperature	-25C to +60C
Humidity	5% to 95% Non-condensing
Approvals	
MTA Agency Approvals	See Preface section, Approvals Table

Note

Fuses are available as spare parts from Siemens.

Fuse information can be found at:

<http://www.bussmann.com>

See the Section 8.10, *Hardware Configuration*, for more information.

8.8 Module Restrictions

Restrictions for 8-Channel TC Input MTA (6ES7650-1AF51-2XX0 or 6ES7650-1AF50-2XX0)	
I/O Module Restrictions	
MTA Design	External Junction Compensation only
Module Accuracy	
External Compensation Accuracy	+/-0.3C or 0.6% of terminal temperature

8.9 Typical Thermocouple Connection to Field Terminals

Figure 8–2 Typical Thermocouple Connection to Field Terminals

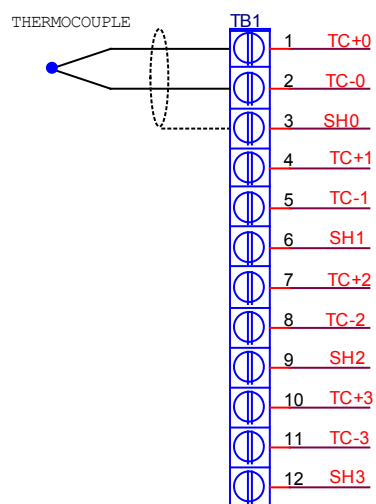

8.10 Hardware Configuration

Neither the 8-Channel Thermocouple Module nor the MTA supports redundant operation.

8.10.1 Addresses

Input address and process image should be set to the user preferences.

Figure 8–3 8-Channel TC Input Hardware Configuration: Address Setup

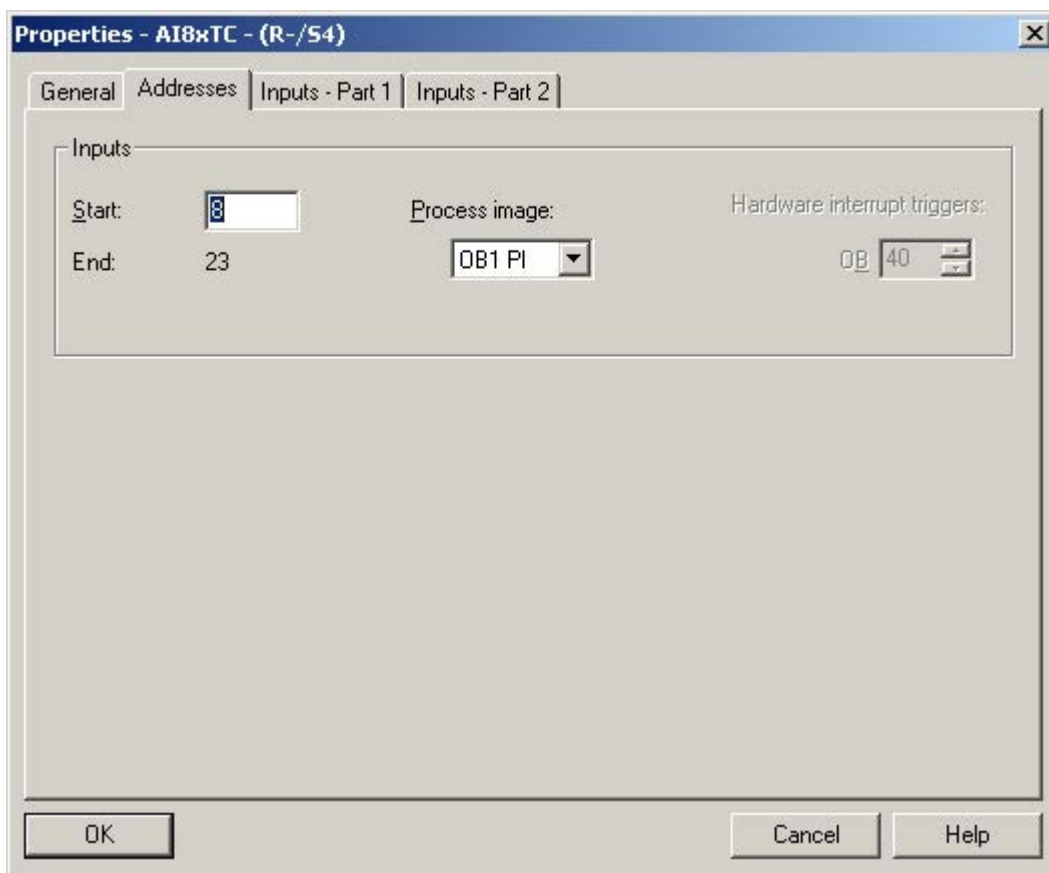

8.10.2 Inputs – Part 1

Under the **Inputs – Part 1** tab the **Measuring Type** field must be set to **TC-EL** (External Compensation) or deactivated. The other settings are user preferences.

Figure 8–4 shows all the TC **Measuring Ranges** as **Type J** but they can be any type or mixed as described in the TC module manual. All other settings are user preferences.

Figure 8–4 8-Channel TC Input Hardware Configuration: Inputs – Part 1 Parameters

Input Group	0-1	2-3	4-5	6-7
Enable	<input type="checkbox"/>	<input type="checkbox"/>	<input type="checkbox"/>	<input type="checkbox"/>
Diagnostics				
Group Diagnostics:	<input type="checkbox"/>	<input type="checkbox"/>	<input type="checkbox"/>	<input type="checkbox"/>
with Check for Wire Break:	<input type="checkbox"/>	<input type="checkbox"/>	<input type="checkbox"/>	<input type="checkbox"/>
Measuring				
Measuring Type:	TC-EL	TC-EL	TC-EL	TC-EL
Measuring Range:	Type J	Type J	Type J	Type J
Reaction to Open Thermocouple:	Overflow	Overflow	Overflow	Overflow

Note

Under the **Inputs – Part 1** tab, the **Measuring Type** field must be set to **TC-EL** (External Compensation) or deactivated.

8.10.3 Inputs – Part 2

Figure 8–5 shows the **Temperature Unit** set to **degrees Fahrenheit**, but **degrees Celsius** is also possible. All settings should reflect user preferences.

Figure 8–5 8-Channel TC Input Hardware Configuration: Inputs – Part 2 Parameters

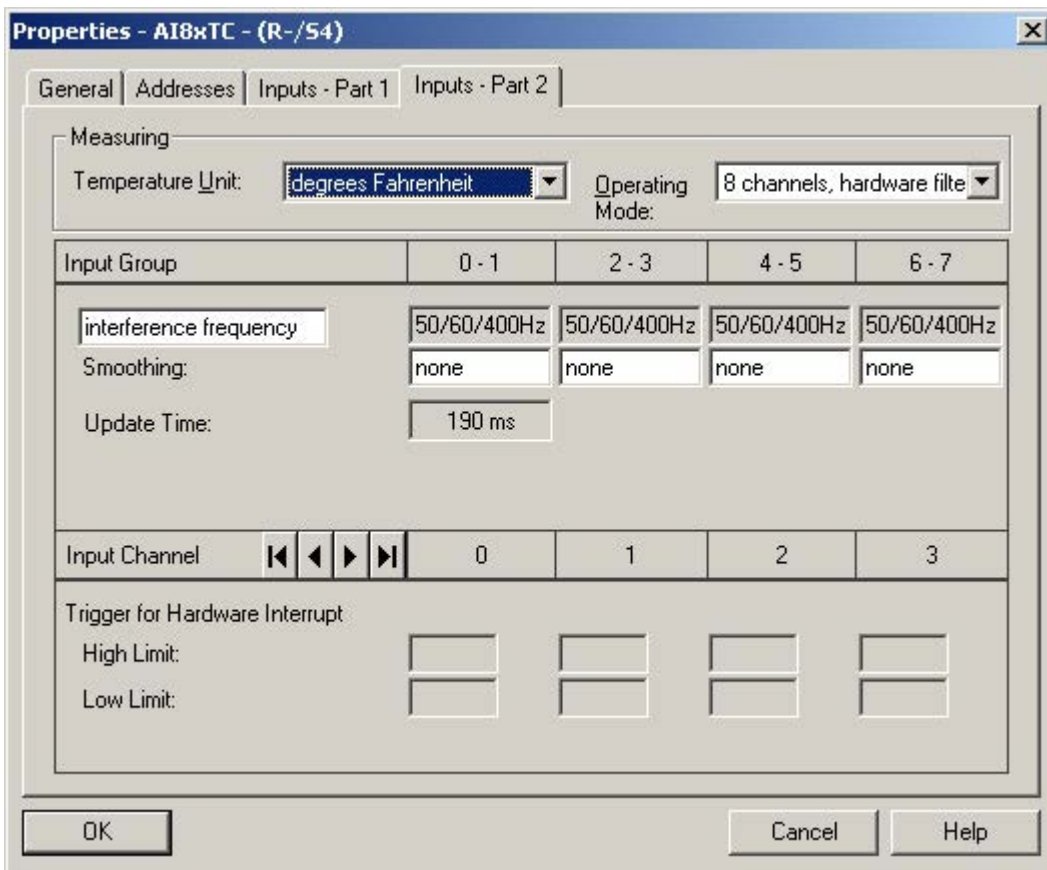

8.11 Technical Specifications for 8-Channel TC Input Module (6ES7 331-7PF10-0AB0 & 6ES7 331-7PF11-0AB0)

Note

For a complete functional description and the most current technical specifications for this module, refer to the manual *S7-300 Programmable Controller Module Specifications* (document number A5E00105505).

9 6-Channel F Analog Input MTA

9.1 6-Channel F Analog Input MTA

Part No. 6ES7650-1AH51-5XX0 or 6ES7650-1AH50-5XX0

9.2 Description

This section contains installation information and requirements for the Siemens Marshalled Termination Assembly (MTA) (6ES7650-1AH51-5XX0 or 6ES7650-1AH50-5XX0), designed to interface with the Siemens ET 200M 6-Channel F Analog Input Module (6ES7 336-1HE00-0AB0, E-Stand 6 or higher).

Note: The only major difference between the two part numbers is the housing. The Anthracite Gray housing is the latest design. Functionality of both part numbers is the same.

9.3 Features

The following features have been incorporated into this MTA:

- Redundant power connections
- LED indication of redundant power supply condition
- Power monitor plug-in available (optional)
- LED indication of power supply to the field device on an individual channel basis
- Per channel fusing of field power
- Dual connectors for redundant I/O Module operation
- Diode boards and FET Switch Adapters are pluggable for maintenance
- Per module power fusing
- Shield connections available for channel cabling
- Ground stud for connecting shield to earth ground
- Power input and field terminations are pluggable for easy maintenance
- Connectivity for HART Handheld Terminal (HHT) per channel

9.4 Operation

The Fail-Safe Analog Input MTA consists of the

- Main board
- Two diode boards
- FET Switch Adapters

The diode board marked **1** (MLFB 6ES7650-1BC51-0XX0 or 6ES7650-1BC50-0XX0) uses 6.2 VDC zener diodes. The diode board marked **2** (MLFB 6ES7650-1BB51-0XX0 or 6ES7650-1BB50-0XX0) uses 5.6 VDC zener diodes. The FET Switch Adapters are required to make proper operation possible under all circumstances.

The two diode boards make maintenance of redundant modules possible. The diode boards plug in to the main board and can be removed for testing and maintenance without affecting operation of the input module. The FET Switch Adapters disconnect the input signals from the FAI module in the event of an I/O power failure or FAI power failure.

Power is supplied via the two removable power connectors which are retained by screws and marked **L+A, MA**, and **L+B, MB**. Each has a LED to indicate the presence of voltage over 15 VDC. The LEDs are marked **A POWER** and **B POWER**. There is also a connector (**J3**) for a Power Monitor board used to indicate the presence of both A and B power. See Section 19, *Power Monitor Board* (6ES7650-1BA02-0XX0).

Incoming power from **A** and **B** is diode OR'd, in **CR106**, to provide the MTA and the module power from either input source. The output from **CR106** is sent to the I/O modules via the module fuses and to the channels via the channel fuses. Module Fuse 1 (**F100**) supplies the I/O Module plugged into **J1** and Module Fuse 2 (**F101**) supplies power to the I/O Module plugged into **J2**.

Each channel has an LED to indicate the presence of power and the fuse status. If there is no power or the fuse is open, then the LED remains off. If there is power and the fuse is good, then the LED is illuminated.

Since the modules can only be used with current inputs when in safety mode, there is no provision on the MTA to allow voltage input operation.

Field Terminals, Channel + (**Ix+**), Channel – (**Ix-**), Sensor power (**PWRx**) and Shield (**SHx**), connect to the field devices. **PWRx** is the +24 VDC power feed and is fused on a channel-by-channel basis. The field termination connector is removable for ease of wiring maintenance and is retained by friction.

For redundant I/O Modules, the Ix- connects to the I/O modules input via J1 and J2. If both modules are present, then the diodes on boards 1 and 2 are passive, but ensure that if either module is removed for maintenance, the input signals to the remaining module are not interrupted. Redundant operation uses the MTA, two zener diode boards, two FET switch adapters, and two FAI modules. A simplified diagram of redundant use of the FAI module and MTA is shown in Figure 9–1

For a non-redundant I/O module, the **Ix-** connects to the I/O module input via the diodes on Diode Board **1**. The diodes on Diode Board **1** conduct the signal to the non-redundant module plugged into **J2**. In this case the diodes on board **2** are passive. Non-redundant modules should be plugged into **J2** to insure the best common-mode rejection. Non-redundant operation uses the MTA, two Zener Diode Boards, one FET Switch Adapter, and the FAI module. A simplified diagram of Non-redundant use of the FAI module and MTA is shown in **Figure 9-2**.

Note

Use of the FAI MTA for non-redundant operation requires that the FAI I/O to MTA cable be installed into **J2** on the MTA.

Figure 9-1 Redundant FAI Interface

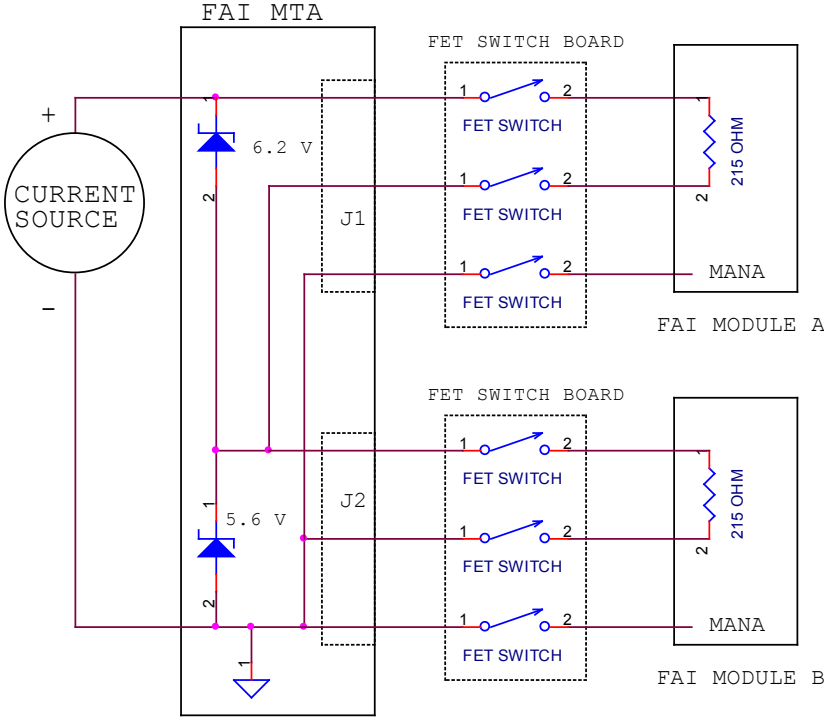
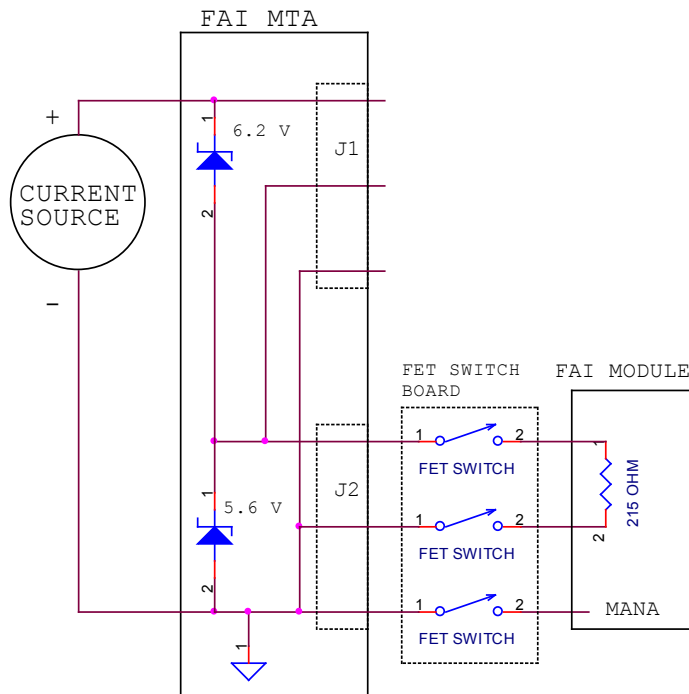

Figure 9–2 Non-Redundant FAI Interface



9.5 Installation Requirements

See Section 2, *Installation*, before performing any installation and observe all warnings

A common interconnecting cable (6ES7922-3BD00-0AS0 or 6ES7922-3BJ00-0AS0), supporting six analog input channels, interconnects the analog input termination assembly to the 6-channel analog input module (6ES7 336-1HE00-0AB0, E-Stand 4 or higher). See Figure 2-28.

It may be necessary to modify the printed circuit board as follows:

To disconnect the interconnecting cable shield from ground at the MTA only, cut and remove the shield disconnect jumper, **W100** and **W101**, for the associated cable.

Note

- To separate channel input low from power supply common, cut and remove the jumper **W200**. This will provide isolation between the all the inputs and power return.
- W200** should never be cut when an FAI module is connected to J1 on the MTA. Doing so will cause the input to exceed the common mode specification and will generate a common-mode diagnostic error.

9.6 Maintenance

See Section 3, *Maintenance*, before performing any maintenance and observe all warnings

Under normal operation, the **A/B Power LED**, the **Module 1/2 Fuse LED**, and all the **Channel Fuse LEDs** are on. If all are off, check the power supply to MTA. If the **A/B Power LED** is off, check the power supply to the MTA. If the **Module 1/2 Fuse LED** is off, check and replace the module fuse. If the **Channel Fuse LED** is off, check the channel fuse and replace as necessary.

Periodically the diode boards should be tested to verify that the zener diodes will operate correctly. Testing consists of connecting a DC power supply with a current-limiting series resistor across each diode. The power supply should provide ≤ 20 mA at 15 to 24 VDC. The voltage measured across the zener diodes on the #1 board should be the device's nominal specification of 6.2 VDC and on the #2 board should be the device's nominal specification of 5.6 VDC.

The FET Switch Adapter should also be tested to insure it is operating properly. Testing consists of turning on the FET Switches, verifying that they conduct, then turning off the FET Switches and verifying that they do not conduct.

Note

Correct power down and power up of the FAI module and FET switches is crucial to the proper operation of the system. The proven procedure for removal and re-installation of the FAI module is as follows:

1. Remove the MTA-I/O cable connector from the FAI module.
 2. Remove the FAI module from the backplane.
 3. Perform FAI module maintenance as required.
 4. Reinstall the FAI module into the backplane.
 5. Reinstall the MTA-I/O cable connector onto the FAI module.
-

9.7 6-Channel F Analog Input Marshallled Termination Assembly

Figure 9–3 shows the basic parts of the 6-Channel F Analog Input MTA.

Figure 9–3 6-Channel F Analog Input Marshallled Termination Assembly

(6ES7650-1AH51-5XX0 or 6ES7650-1AH50-5XX0)

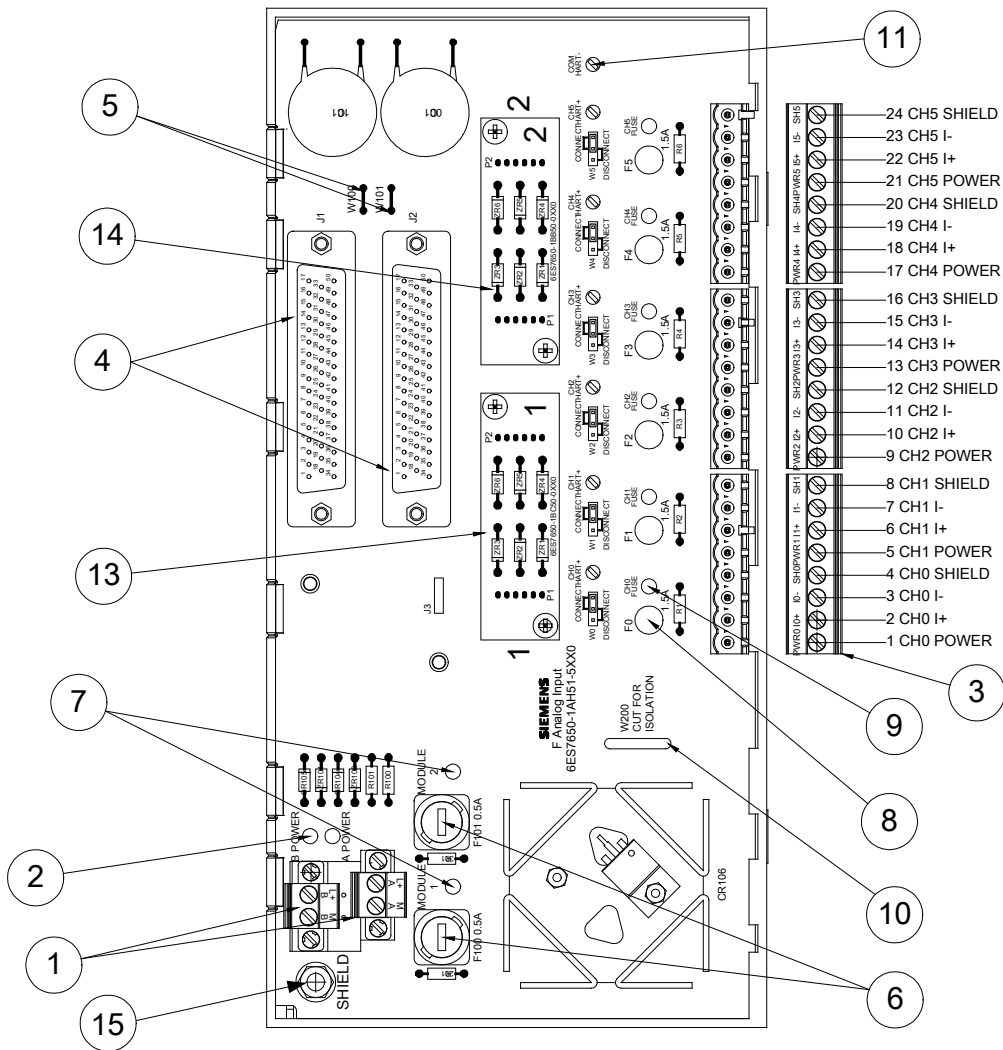

Key to numbered items in Figure 9-3:	
Item	Description
1	Input power connections
2	Input power indicators
3	Field wiring connections
4	I/O module connections
5	Shield disconnect jumper (W100 & W101)
6	Module power fuses
7	Module power fuse indicators
8	Channel power fuse (1 of 6)
9	Channel power fuse indicator (1 of 6)
10	Input isolation Jumper (W200)
11	HART connectivity terminals
12	Channel Input Disconnect Jumper (W0 – W5)
13	6.2V Zener Diode Boards (1)
14	5.6V Zener Diode Boards (2)
15	Shield Ground Stud for connecting to earth ground

9.8 Technical Specifications

Technical Specifications for 6-Channel F Analog Input MTA (6ES7650-1AH51-5XX0 or 6ES7650-1AH50-5XX0)	
Dimensions - See Section 1, Figure 1.3, Long Version	
Mounting	
DIN Rail	35mm (deep top hat style)
Power Input	
Voltage Input for Single or Redundant Feed	21.6 to 28.8 VDC
Current Consumption (nominal ratings; all channels connected)	
Inrush	9.368 A maximum (Includes 9.000 A for transmitter inrush)
Normal	0.5 A maximum
Terminal Block Wire Sizes	TB100 & TB101
Wire Size – US	24 – 14 gauge AWG
Wire Size – Metric	0,205 – 2,08 mm sq.
Power Supply Specifications	See Module Specs
Fuse Ratings	
Individual channel	1.5 A Fast blow (Littelfuse P/N: 273 01.5) (Siemens Spare P/N: A5E01568886)
Module Power	0.5 A (Bussmann P/N: GMA-0.5A) (Siemens Spare P/N: A5E01568885)
Indicators	
Input Power	Green LED on when input power available
Module Power	Green LED on when module power available
Channel Power	Green LED on when sensor power available
Field Terminal Block Wire Sizes TB1 – TB3	
Wire Size – US	24 – 14 gauge AWG
Wire Size – Metric	0,205 – 2,08 mm sq.
Environmental	
Ambient Temperature	-25C to +60C
Humidity	5% to 95% Non-condensing
Approvals	
MTA Agency Approvals	See Preface section, Approvals Table
Max achievable Safety Integrity Level in safety mode	
In Accordance with IEC 61508	SIL 3
Fail-safe performance characteristics	
Low demand mode (average probability of failure on demand) per channel	PFDavg <1E-4 @60C
High demand / continuous mode (probability of a dangerous failure per hour per channel)	PFH < 1E-9
Proof-test interval	20 years

Note

Fuses are available as spare parts from Siemens.

Fuse information can be found at:

<http://www.littelfuse.com>

<http://www.bussmann.com>

Note

When using a 1.5A channel fuse it is possible that one or more of the zener diodes on the two Zener Diode Boards may be damaged in the event of a short circuit in the field. It is recommended that the diode boards be tested or replaced in the event a 1.5A channel fuse opens.

9.9 Module Restrictions

Restrictions for 6-Channel F Analog Input MTA (6ES7650-1AH51-5XX0 or 6ES7650-1AH50-5XX0)	
I/O Module Restrictions	
MTA Design	Only 1 transmitter can be connected to a channel.
MTA Design	
Current Input Range	0 – 20 mA & 4 – 20 mA
Voltage Input Range	None. Voltage Mode not available
MTA Design: Module Vs is used to supply the FET Switch Adapter.	FET Switch Adapter current consumption = 25 mA
MTA Design – Redundant Operation	Max Input Signal Input Current = 20.0 mA²
MTA Design – Redundant Operation	Isolation Jumper, W200, must be connected ³
MTA Design	Worst case FAI MTA input channel voltage drop = 11.4 V ⁴
Module Accuracy	
Current Input	The MTA and an 8 meter cable add $\pm 0.3\%$ to the error limit specification of the module for channels 0 - 3. The 3 meter cable adds $\pm 0.1\%$. To improve the accuracy with the MTA, use the following configuration: Module Parameter- Type of Sensor Interconnection: <u>2 Sensors</u> (There is actually only one sensor connected.) Channel Parameter- Unit Value: <u>MIN</u> (Unit Value refers to the value returned by the F-AI module to the CPU.)

² Maximum channel input current without generating a diagnostic error

³ See Section 8.5

⁴ This is calculated with an input current of 20 mA

9.10 Typical Transmitter Connection to Field Terminals

Figure 9-4 Transmitter Connection to Field Terminals

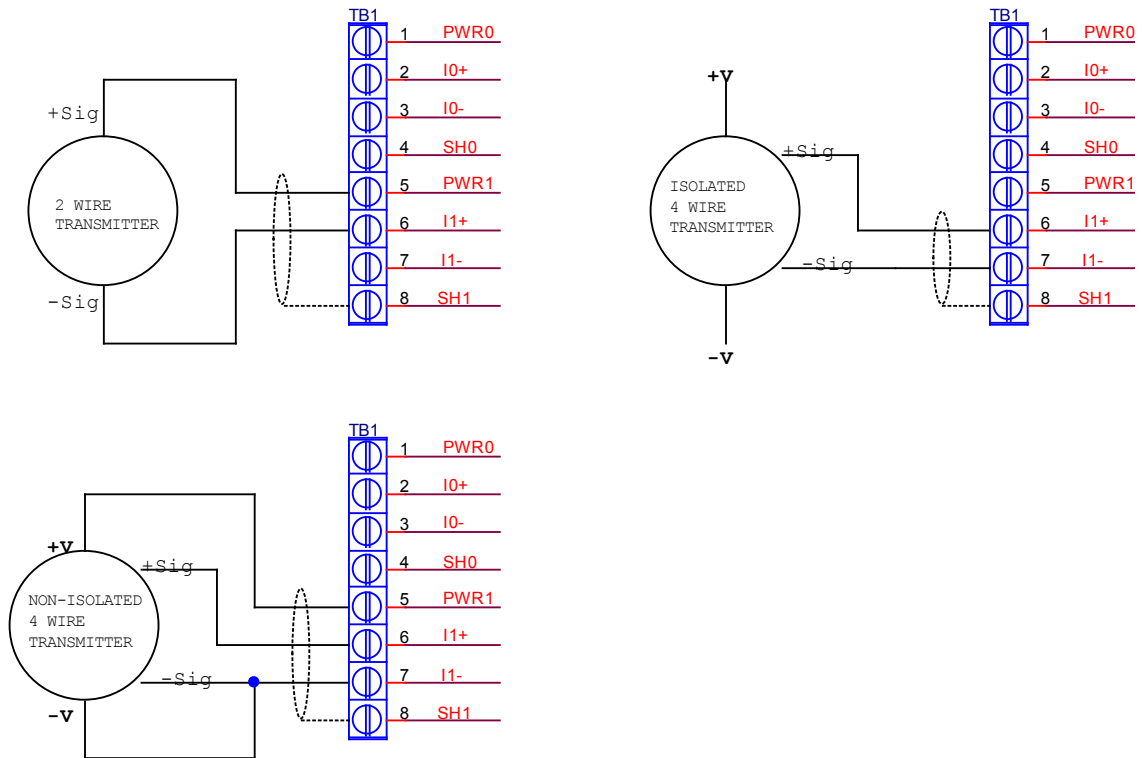

9.11 Hardware Configuration

Under normal operation the hardware configuration can be set up as shown in Figure 9–5 through Figure 9–8.

9.11.1 Addresses

Figure 9–5 shows redundant operation, in which the **Process Image** blocks should be changed from the default. Non-redundant operation does not require such a change.

Figure 9–5 6-Channel F Analog Input Hardware Configuration: Address Setup for Redundant Operation

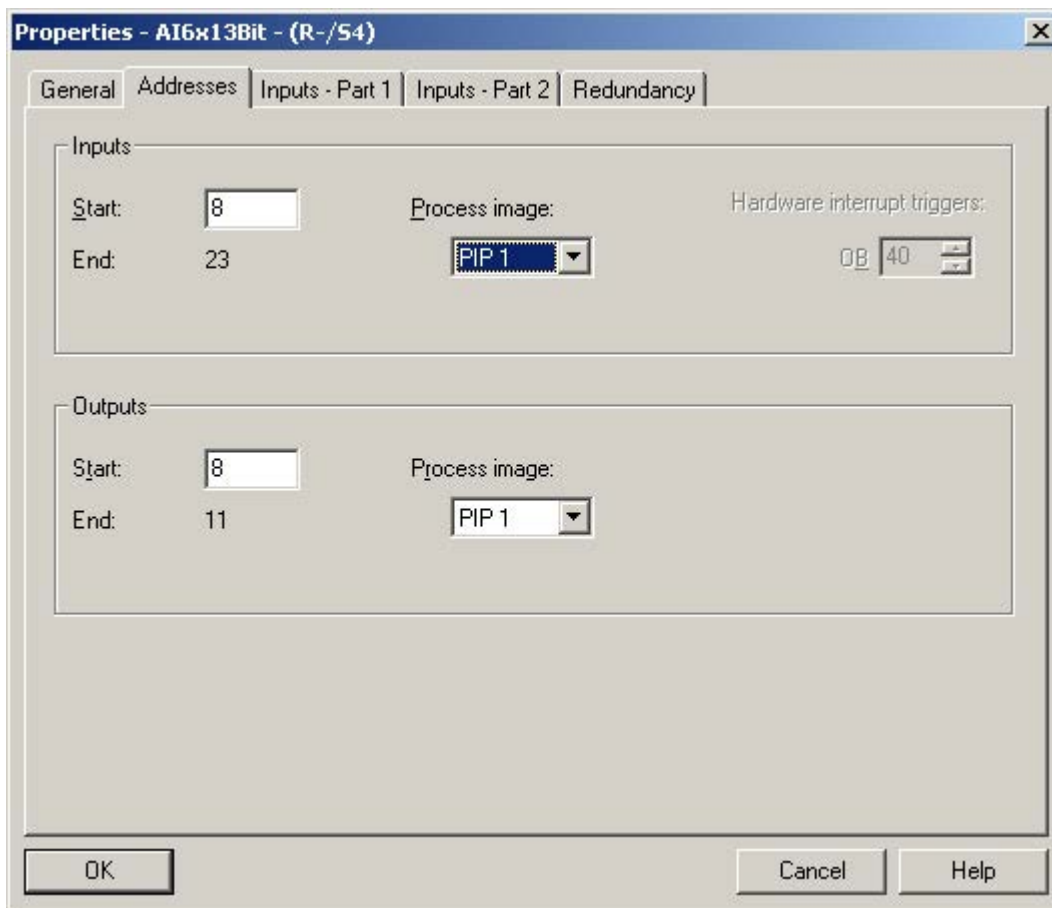

9.11.2 Inputs – Part 1

Figure 9–6 shows the all the diagnostic boxes checked. The Measurement type can be either 2WMT, 4WMT, or Deactivated.

Figure 9–6 6-Channel F Analog Input Hardware Configuration: Inputs – Part 1 Parameters

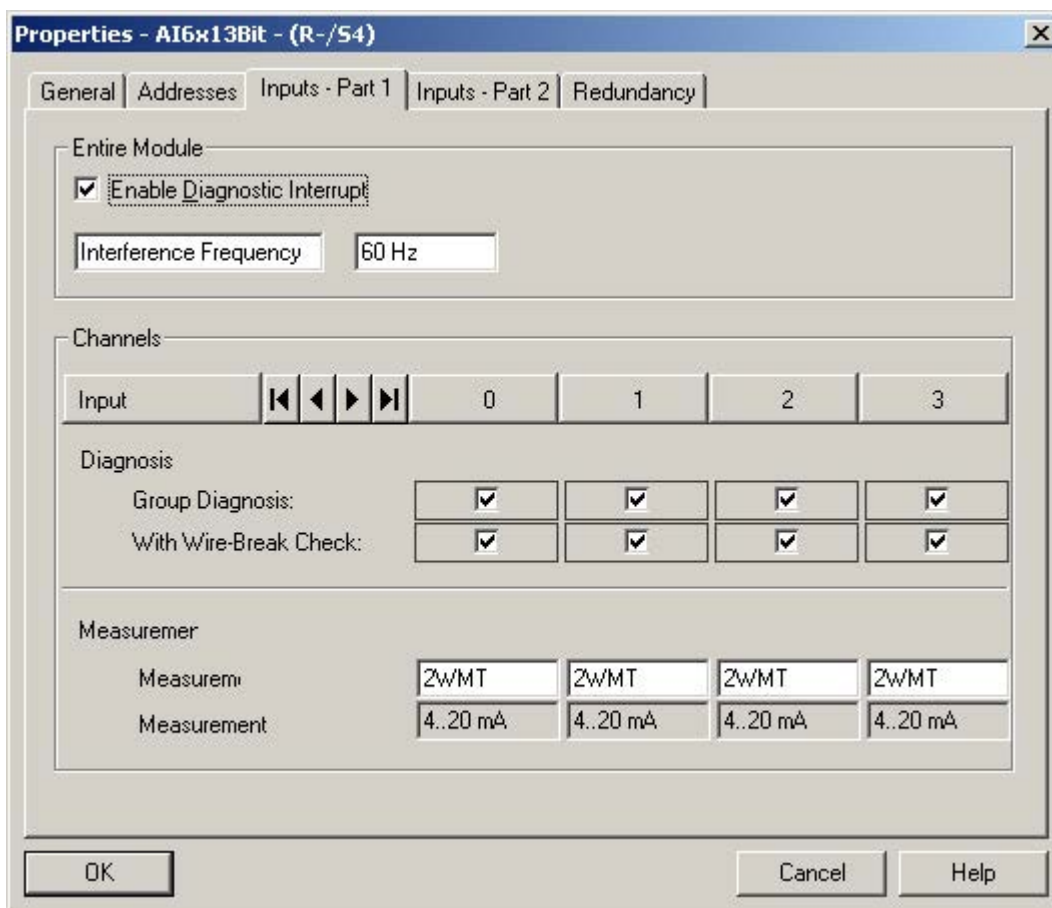

9.11.3 Inputs – Part 2

Figure 9–7 shows the **Safety Mode** option selected. Single sensor input is shown although two sensors can be chosen. The **Monitoring Time** may need to be adjusted.

Figure 9–7 6-Channel F Analog Input Hardware Configuration: Inputs – Part 2 Parameters

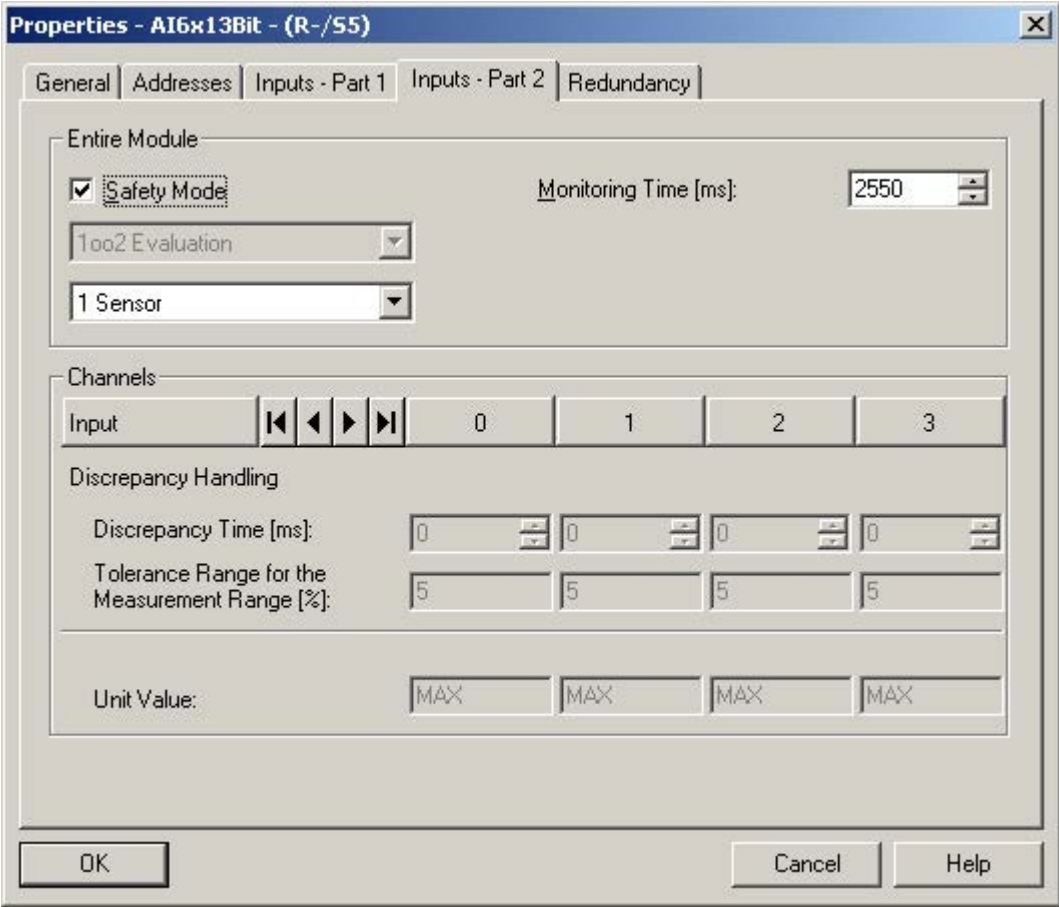

9.11.4 Redundancy

Figure 9–8 shows the redundant configuration. For non-redundant operation the **Redundancy** box should be set to **None**.

Figure 9–8 6-Channel F Analog Input Hardware Configuration: Redundancy Setup

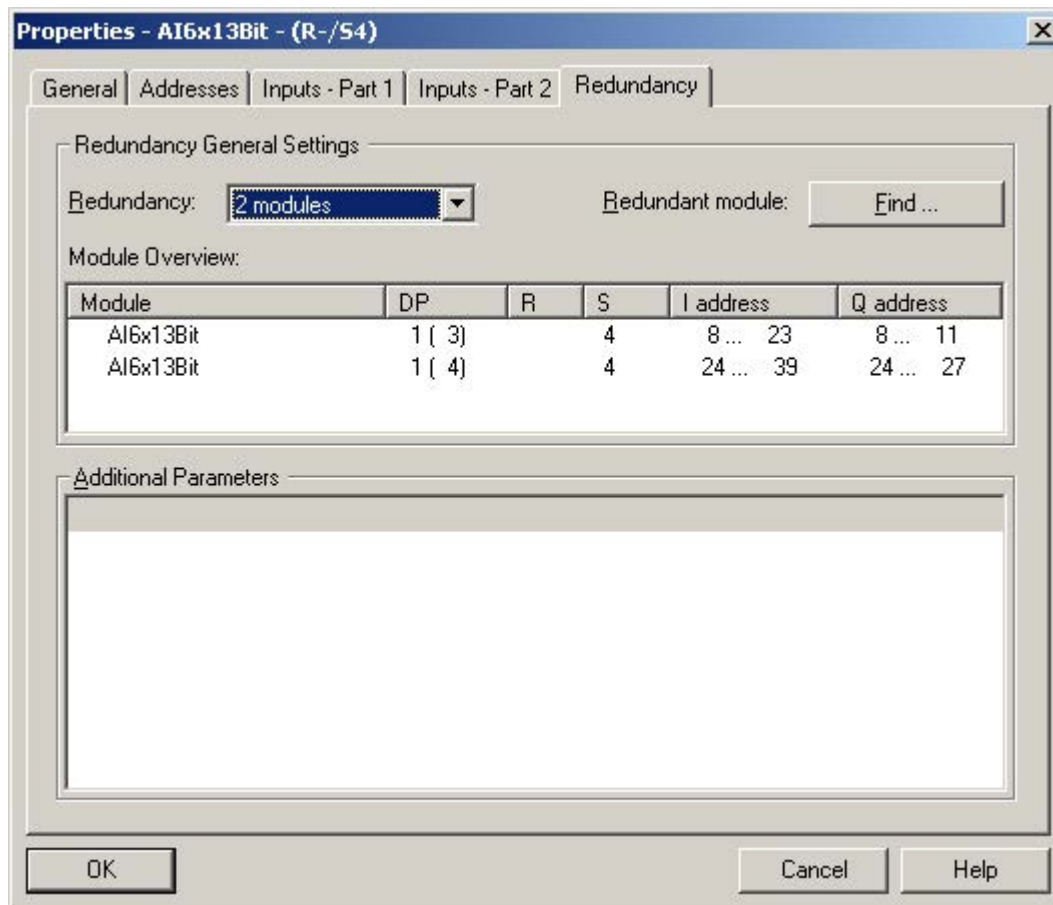

9.12 Technical Specifications for 6-Channel F Analog Input Module (6ES7 336-1HE00-0AB0)

Note

For a complete functional description and the most current technical specifications for this module, refer to the manual *S7-300 Automation System Fail-Safe Signal Modules* (document number A5E00085586).

9.13 Zener Diode Boards

Part No. 6ES7650-1BB51-0XX0 or 6ES7650-1BB50-0XX0 and 6ES7650-1BC51-0XX0 or 6ES7650-1BC50-0XX0

9.13.1 Description

This section contains installation information and requirements for the two Siemens Zener Diode Boards. The 6.2 VDC (6ES7650-1BC51-0XX0 or 6ES7650-1BC50-0XX0) and the 5.6 VDC (6ES7650-1BB51-0XX0 or 6ES7650-1BB50-0XX0) are used on the ET200M Marshalled Termination Assembly (MTA) (6ES7650-1AH51-5XX0 or 6ES7650-1AH50-5XX0) designed to interface with the Siemens ET 200M 6-Channel F Analog Input Module (6ES7 336-1HE00-0AB0, E-Stand 4 or higher).

Note: The two part numbers for the 5.6 V Diode Board are interchangeable. The two part numbers for the 6.2 V Diode Board are also interchangeable. Do not interchange 5.6 V Diode Boards with 6.2 V Diode Boards.

9.13.2 Operation

The 6.2 VDC and the 5.6 VDC Zener Diode Board allows proper operation of the 6 Channel Failsafe Analog Input Module with the MTA. Because the FAI may only be used in current mode when used in the Safety mode, diodes are placed in parallel with the module inputs. One diode spans one channel on one module; therefore, one diode board handles one module. The diodes are normally not conducting but when a module or the interconnecting cable is removed, the diodes conduct and keep the current constant for the other module. In a redundant system none of the diodes normally conducts, but in a non-redundant system one set is always conducting. Figure 9–9 shows a simplified schematic.

Figure 9-9 Diode Board Interfaces

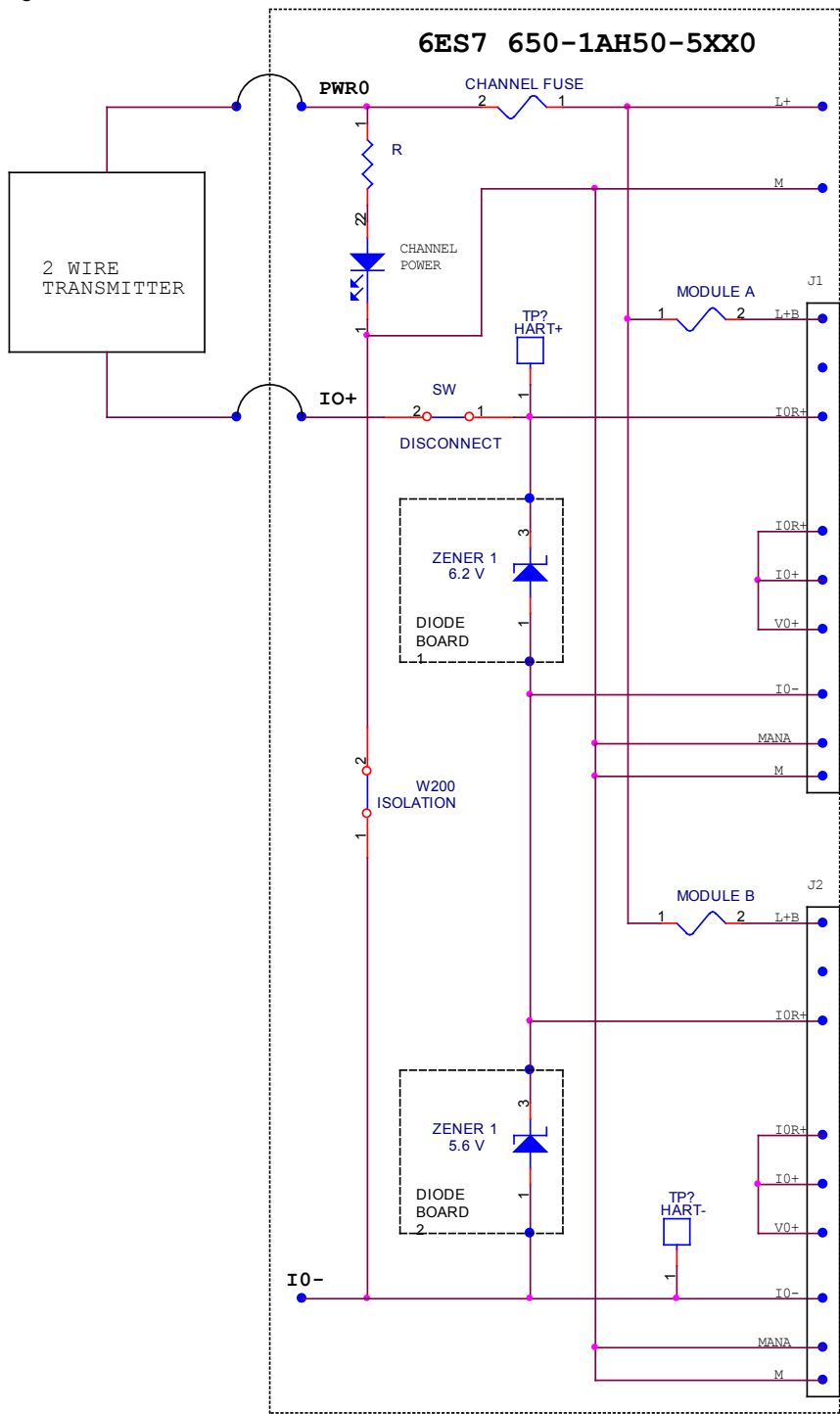

9.13.3 Installation Requirements

See Section 2, *Installation*, before performing any installation and observe all warnings

The 6.2 VDC Zener Diode Board, marked **1** is plugged into **J100** and **J101** on the FAI MTA. It is mechanically held down by two captive screws and standoffs. See Figure 9–11.

The 5.6 VDC Zener Diode Board, marked **2** is plugged into **J200** and **J201** on the FAI MTA. It is mechanically held down by two captive screws and standoffs. See Figure 9–12.

9.13.4 Maintenance

See Section 3, *Maintenance*, before performing any maintenance and observe all warnings

Under normal operation, the diodes on the diode board do not conduct. Periodic maintenance of the FAI modules requires that the diode boards operate correctly, so the diode boards should be tested before one of the redundant modules is removed from service.

Figure 9–10 5.6V Diode Board Test Setup

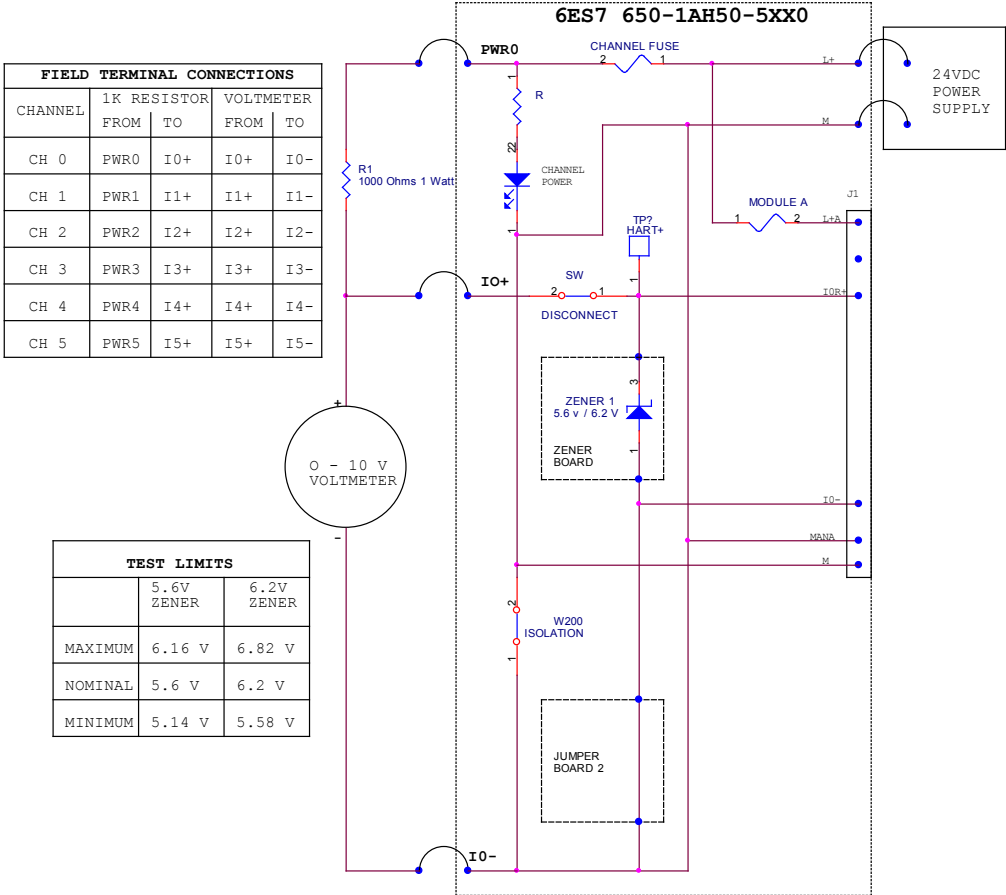

9.14 Diode Board Assembly

The two figures below show the basic parts of the diode boards.

Figure 9–11 6.2V Diode Board Assembly

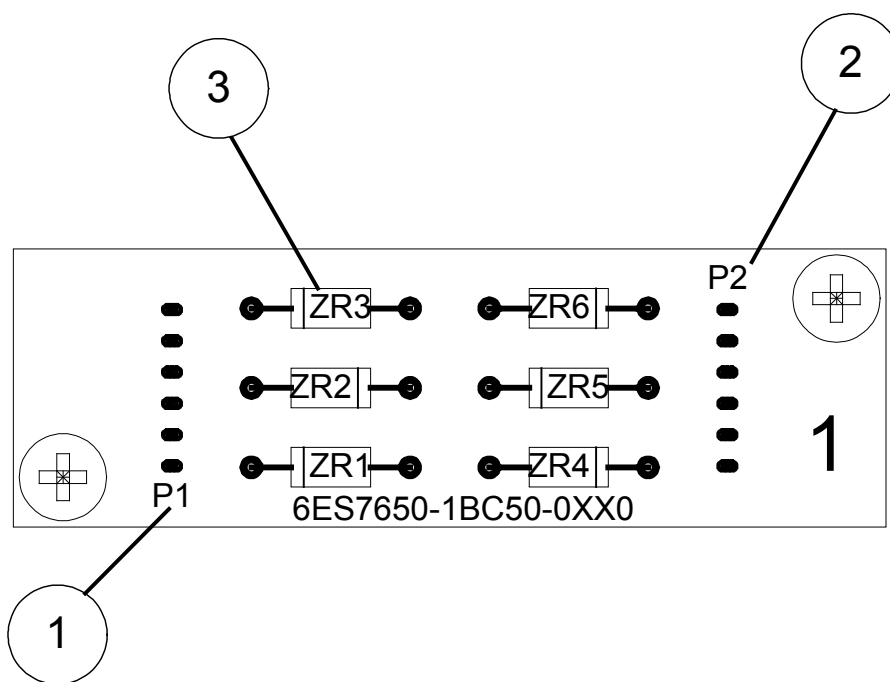

Key to numbered items in Figure 9–11:	
Item	Description
1	P1
2	P2
3	6.2V Zener Diode (1 of 6)

Figure 9–12 5.6V Diode Board Assembly

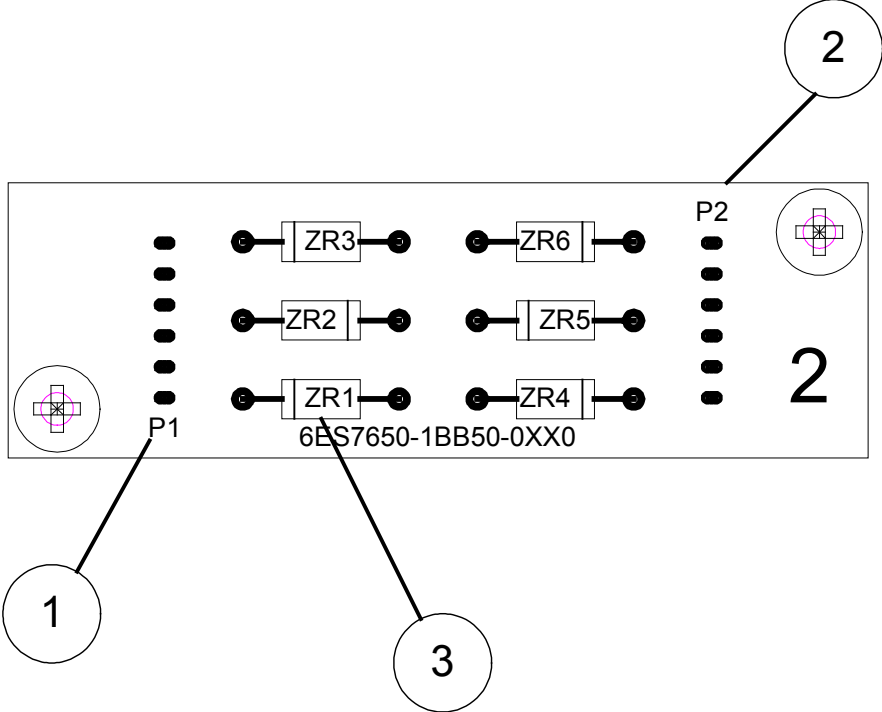

Key to numbered items in Figure 9–12:	
Item	Description
1	P1
2	P2
3	5.6V Zener Diode (1 of 6)

9.15 FET Switch Adapter

Part No. 6ES7650-1BD51-0XX0 or 6ES7650-1BD50-0XX0

9.15.1 Description

This section contains installation information and requirements for the Siemens FET Switch Adapter. The FET Switch Adapter (6ES7650-1BD51-0XX0 or 6ES7650-1BD50-0XX0) is used on the ET200M Marshalled Termination Assembly (MTA) (6ES7650-1AH51-5XX0 or 6ES7650-1AH50-5XX0), which interfaces with the Siemens ET 200M 6-Channel F Analog Input Module (6ES7 336-1HE00-0AB0, E-Stand 4 or higher).

Note: The two part numbers are interchangeable.

9.15.2 Operation

The FET Switch Adapter contains optically coupled electronic switches powered by the FAI modules VS supply. These switches break the input signal path and Mana when power is lost on the FAI module or if the power supply in the FAI module fails. See Figure 9–16.

This opening in the input signal path accomplishes two things:

- First, if the power fails, all the electronics in the module are removed from the circuit so that they cannot affect the other, still active, module.
- Second, when power is restored and the switches close, the FAI module re-integrates correctly into the configuration without causing bumps or process fluctuations.

9.15.3 Installation Requirements

See Section 2, *Installation*, before performing any installation and observe all warnings

The FET Switch Adapter is installed between **J1** on the MTA and the interconnecting cable to the FAI Module. It should be screwed down to prevent vibration or stress from disconnecting it from the MTA.

9.15.4 Maintenance

See Section 3, *Maintenance*, before performing any maintenance and observe all warnings

Under normal operation the switches in the FET Switch Adapter are energized and will conduct the input signal from the MTA to the FAI module input circuitry. Periodic maintenance of the FAI modules requires that the FET Switch Adapter operate correctly, so it should be tested when the FAI module is removed from service.

Figure 9–13 through Figure 9–16 show the FET Switch Adapter test setups.

Figure 9–13 5.6V FET Switch adapter Opto LED Test Setup

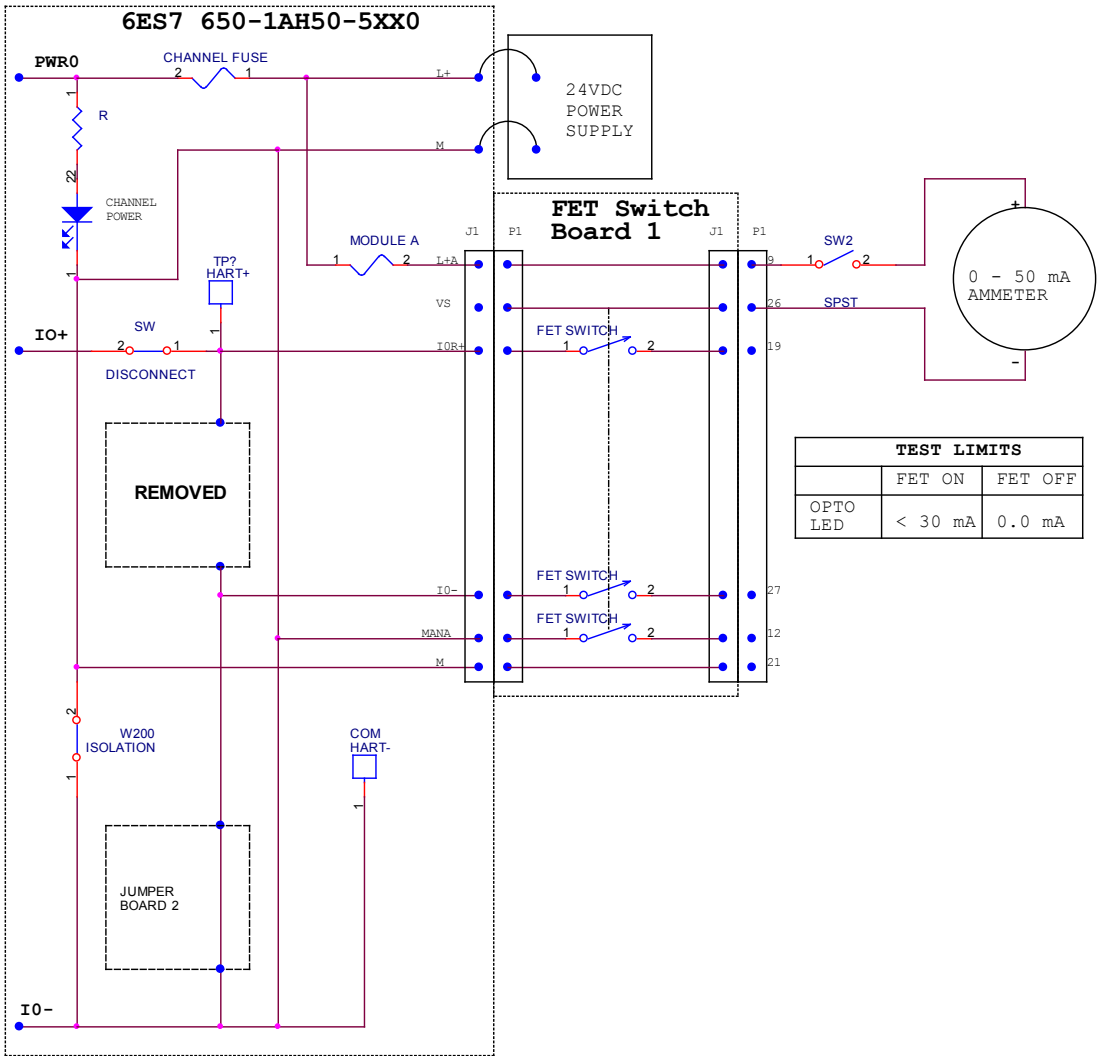
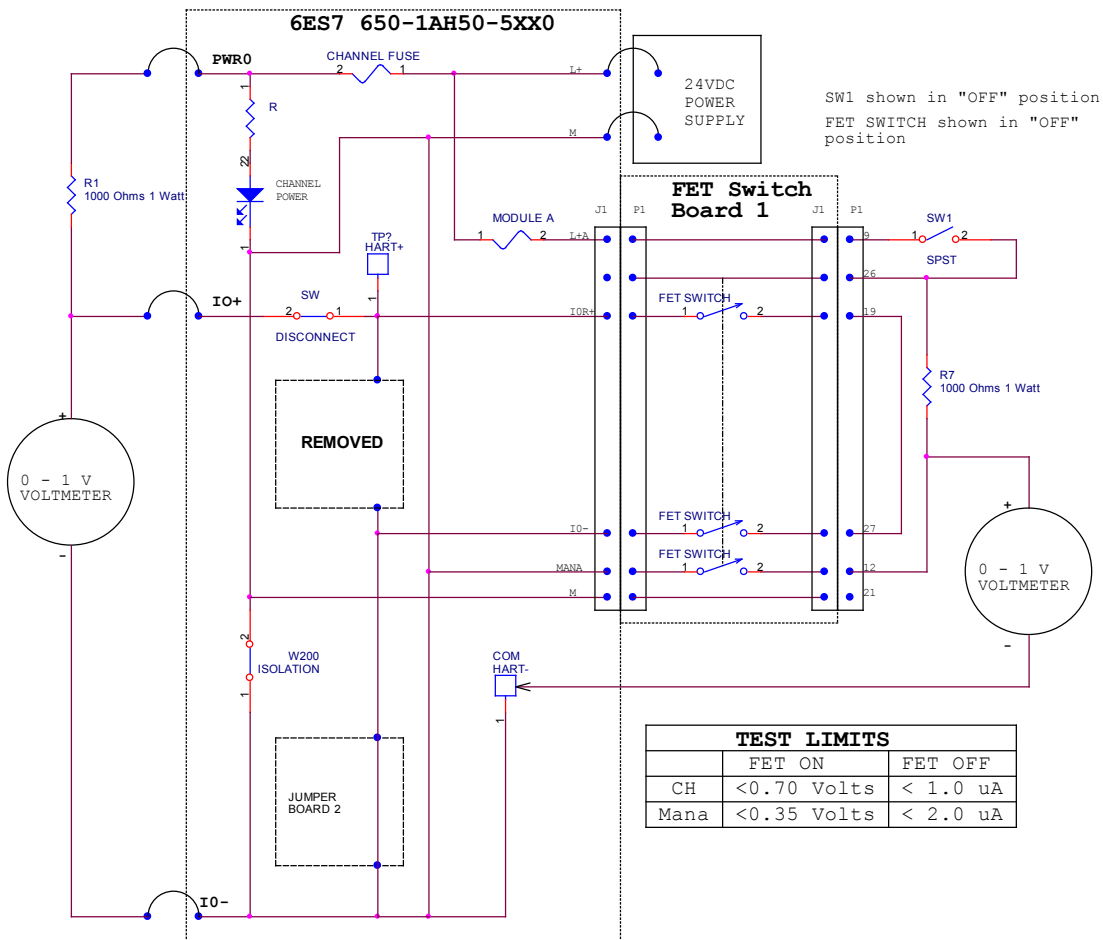

Figure 9-14 FET Switch Adapter FET ON Test Setup



SW1 shown in "OFF" position
FET SWITCH shown in "OFF" position

TEST LIMITS		
	FET ON	FET OFF
CH	<0.70 Volts	< 1.0 uA
Mana	<0.35 Volts	< 2.0 uA

FIELD TERMINAL CONNECTIONS				
CHANNEL	1K RESISTOR		VOLTMETER	
	FROM	TO	FROM	TO
CH 0	PWR0	I0+	I0+	I0-
CH 1	PWR1	I1+	I1+	I1-
CH 2	PWR2	I2+	I2+	I2-
CH 3	PWR3	I3+	I3+	I3-
CH 4	PWR4	I4+	I4+	I4-
CH 5	PWR5	I5+	I5+	I5-

P1 CONNECTIONS		
CHANNEL	WIRE	
	FROM	TO
CH 0	19	27
CH 1	20	28
CH 2	38	46
CH 3	23	47
CH 4	40	15
CH 5	8	32
Mana	26	R7b
	R7a	12
	R7a	VM+
	COM HART-	VM-

Figure 9-15 FET Switch Adapter FET OFF Test Setup

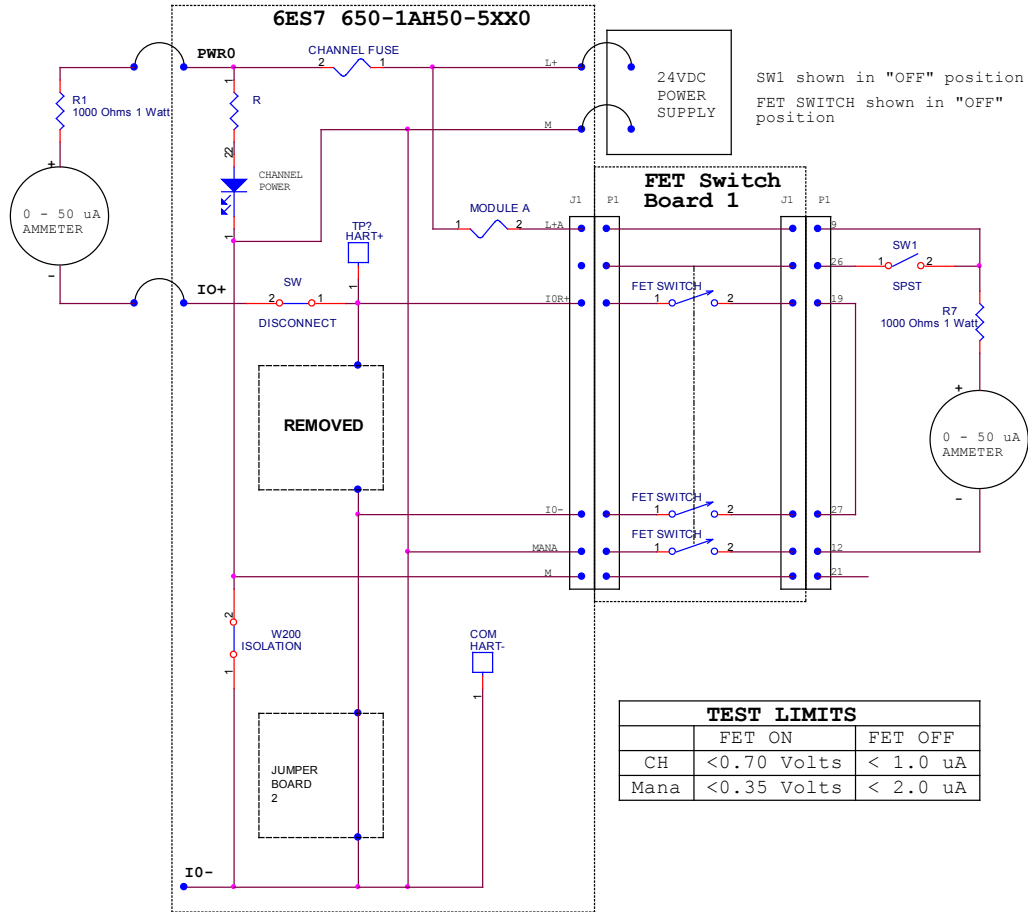

TEST LIMITS		
	FET ON	FET OFF
CH	<0.70 Volts	< 1.0 uA
Mana	<0.35 Volts	< 2.0 uA

FIELD TERMINAL CONNECTIONS				
CHANNEL	1K RESISTOR		AMMETER	
	FROM	TO	FROM	TO
CH 0	PWR0	AM+	R1	I0+
CH 1	PWR1	AM+	R2	I1+
CH 2	PWR2	AM+	R3	I2+
CH 3	PWR3	AM+	R4	I3+
CH 4	PWR4	AM+	R5	I4+
CH 5	PWR5	AM+	R6	I5+

P1 CONNECTIONS		
CHANNEL	WIRE	
	FROM	TO
CH 0	19	27
CH 1	20	28
CH 2	38	46
CH 3	23	47
CH 4	40	15
CH 5	8	32
Mana	9	R7a
	R7b	AM+
	12	AM-

Figure 9–16 FET Switch Adapter Assembly

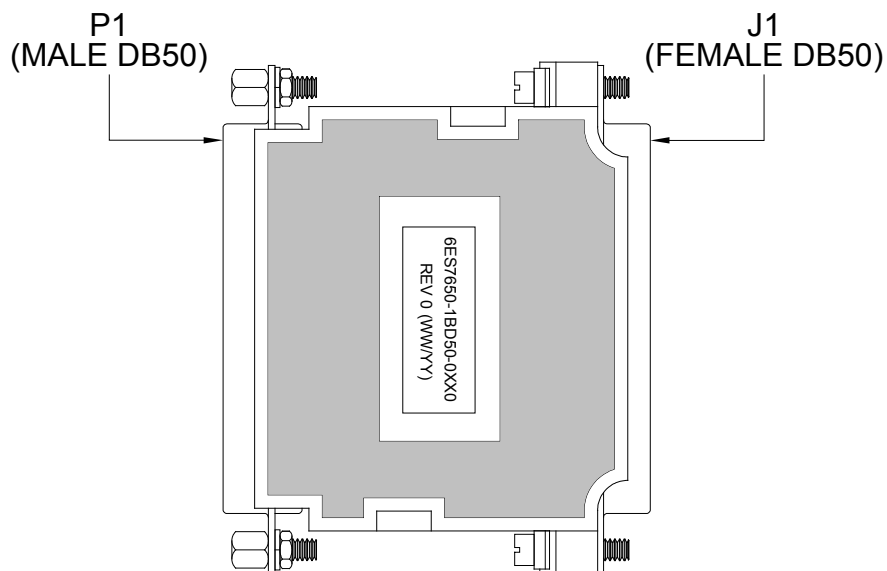

9.15.5 Technical Specifications

Technical Specifications for FET Switch Adapter (6ES7650-1BD51-0XX0 or 6ES7650-1BD50-0XX0)	
Dimensions	
L x W x D – inches	2.5 x 2.75 x 0.75
L x W x D – mm	63.5 x 69.9 x 50.8 x 20
Power Use	
FAI Vs	25 mA
Environmental	
Ambient Temperature	-25C to +60C
Humidity	5% to 95% Non-condensing

9.16 Input Sharing

9.16.1 Description

This section contains information and requirements for input sharing between a Failsafe Analog Input module (6ES7 336-1HE00-0AB0, E-Stand 4 or higher) and a Standard Analog Input Module (6ES7 331-7NF00-0AB0, E-Stand 5 or higher), using the Siemens FAI Marshalled Termination Assembly (MTA) (6ES7650-1AH51-5XX0 or 6ES7650-1AH50-5XX0) and the Siemens AI Marshalled Termination Assembly (MTA) (6ES7650-1AA51-2XX0 or 6ES7650-1AA50-2XX0).

9.16.2 Purpose

Input sharing allows the transmitter signal to be distributed to both the Fail-Safe Analog Input Module and the Standard Analog Input Module. Both systems will then receive the same input data. See Section 9.16.4.

9.16.3 Operation

The signal source is connected to the FAI MTA in the normal manner. The cable plugged into J1 is wired from IxR+ to Ix+ on TBy of the Standard Analog Input (SAI) MTA (6ES7650-1AA51-2XX0 or 6ES7650-1AA50-2XX0) and the Ix- pin to Ix- on TBy of the SAI MTA. The SAI MTA input jumpers (W0 – W7) are set for current mode and the isolation jumpers (W8 – W15) are cut for each channel connected to the FAI MTA. The SAI Module is connected to the SAI MTA using the standard cable. See Table 6-1.

The 6.2V zener diode board is required in position 1 on the FAI MTA. See Figure 9–18.

9.16.4 FAI MTA to SAI MTA Cable

The FAI MTA to SAI MTA Input Sharing cable uses only 13 conductors. The FAI Channel 0 to Channel 5 input signals have been mapped to Channels 0 through 5 on the SAI MTA. Channels 6 & 7 of the SAI can be used for other inputs. The cable connections can be seen in the table below.

The FAI MTA to SAI MTA Input Sharing cable is custom manufactured on a project basis. See the project manager to for more information.

The assembly view of the cable can be seen in Figure 9–17.

Table 9–1 FAI MTA to SAI MTA Cable

FAI Channel	FAI MTA Signal	FAI MTA D50M Pin	SAI MTA Field Terminal	SAI MTA Signal	SAI Channel
CH 0+	I0R+	19	TB1 PIN 2	I0+	CH 0+
CH 0-	I0-	27	TB1 PIN 3	I0-	CH 0-
CH 1+	I1R+	20	TB1 PIN 6	I1+	CH 1+
CH 1-	I1-	28	TB1 PIN 7	I1-	CH 1-
CH 2+	I2R+	38	TB1 PIN 10	I2+	CH 2+
CH 2-	I2-	46	TB1 PIN 11	I2-	CH 2-
CH 3+	I3R+	23	TB1 PIN 14	I3+	CH 3+
CH 3-	I3-	47	TB1 PIN 15	I3-	CH 3-
CH 4+	I4R+	40	TB2 PIN 2	I4+	CH 4+
CH 4-	I4-	15	TB2 PIN 3	I4-	CH 4-
CH 5+	I5R+	8	TB2 PIN 6	I5+	CH 5+
CH 5-	I5-	16,17, 32	TB2 PIN 7	I5-	CH 5-
	Shield	Shield	TB1 PIN 4 ⁵	SH0	

⁵ The shield connection to the SAI MTA is optional and should be investigated for safe operation before use

Figure 9-17 FAI MTA to SAI MTA Interconnecting Cable

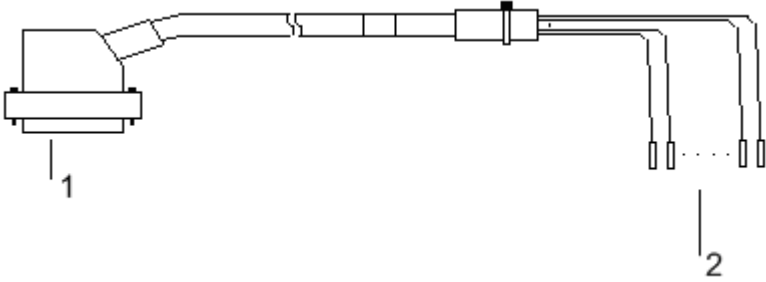

Key to numbered items in Figure 9-17:

Item	Part Name
1	50-PIN FEMALE sub-D connector
2	Wires with crimped pins

Figure 9-18 FAI SAI Input Sharing

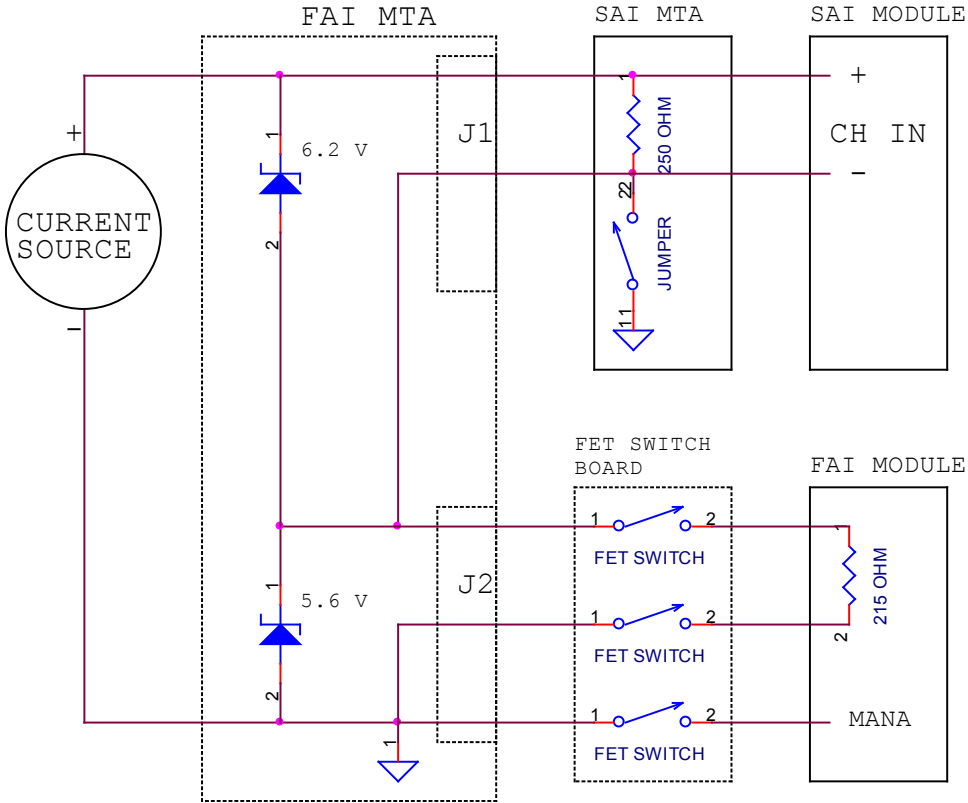

9.16.5 Hardware Configuration

FAI: Redundancy not supported. The HW configuration should be setup for Non-redundant operation. See section 9.11.

SAI: The SAI MTA supports redundancy for the Standard Modules and redundant modules can be used, as selected by the user. See section 4.10.

Addresses

FAI: Input address and process image should be set to the user preferences. See section 9.11.

SAI: Input address and process image should be set to the user preferences. See section 4.10.

Inputs

FAI: Set to user preferences. The **Safety Mode** option must always be checked. See section 9.11.

SAI: Under the **Inputs** tab the **Measuring Type** should be set to **4DMU** (current) with **Measuring Range** set to **4..20 mA**. All other settings are up to the user. See section 4.10.

Figure 6-19 shows SAI inputs 6 and 7 as unavailable. Because the FAI has only 6 inputs the SAI will only use 6 inputs for the sharing operation. The other two inputs can be used for other analog signals.

Figure 9–19 SAI 8-Channel Analog Input Hardware Configuration: Inputs Sharing Configuration

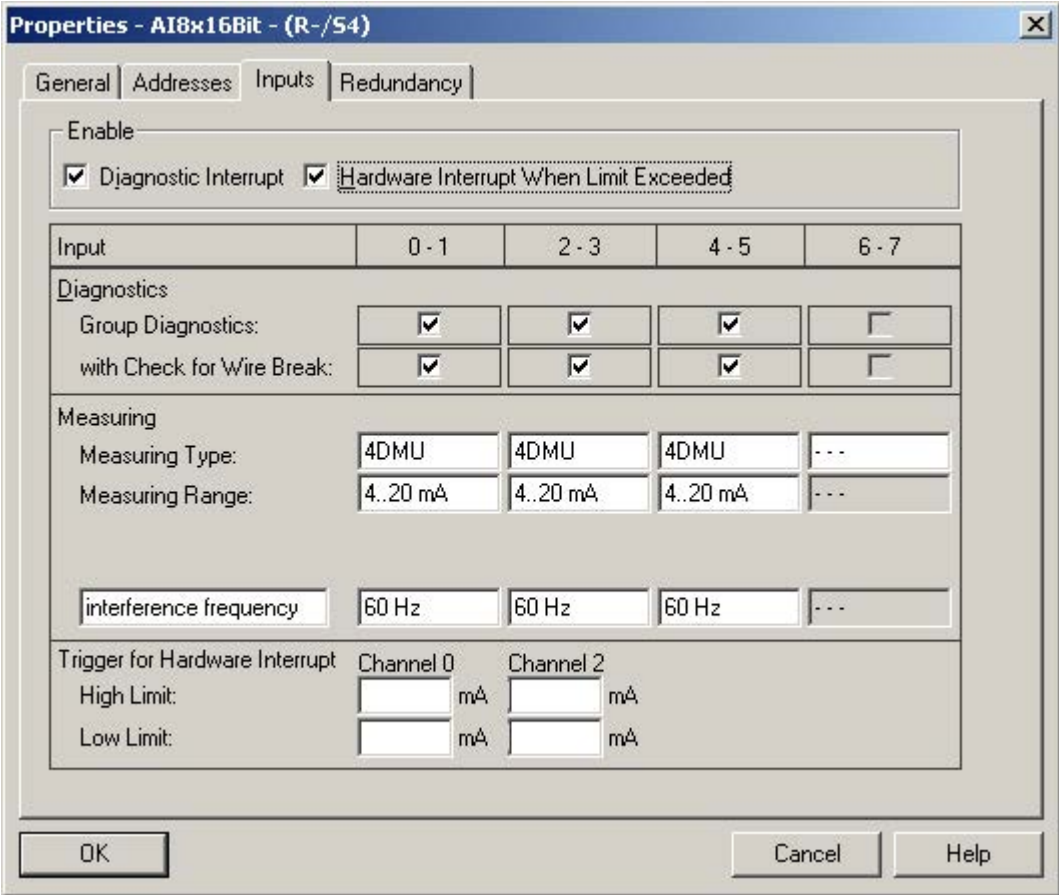

Redundancy

FAI: Redundancy not supported. The HW configuration should be setup for non-redundant operation. See section 9.11.

SAI: The SAI MTA supports redundant and non-redundant operation. See section 4.10.

Figure 9–20 shows a non-redundant SAI configuration.

Figure 9–20 SAI 8-Channel Analog Input Hardware Configuration for Non-redundant Operation

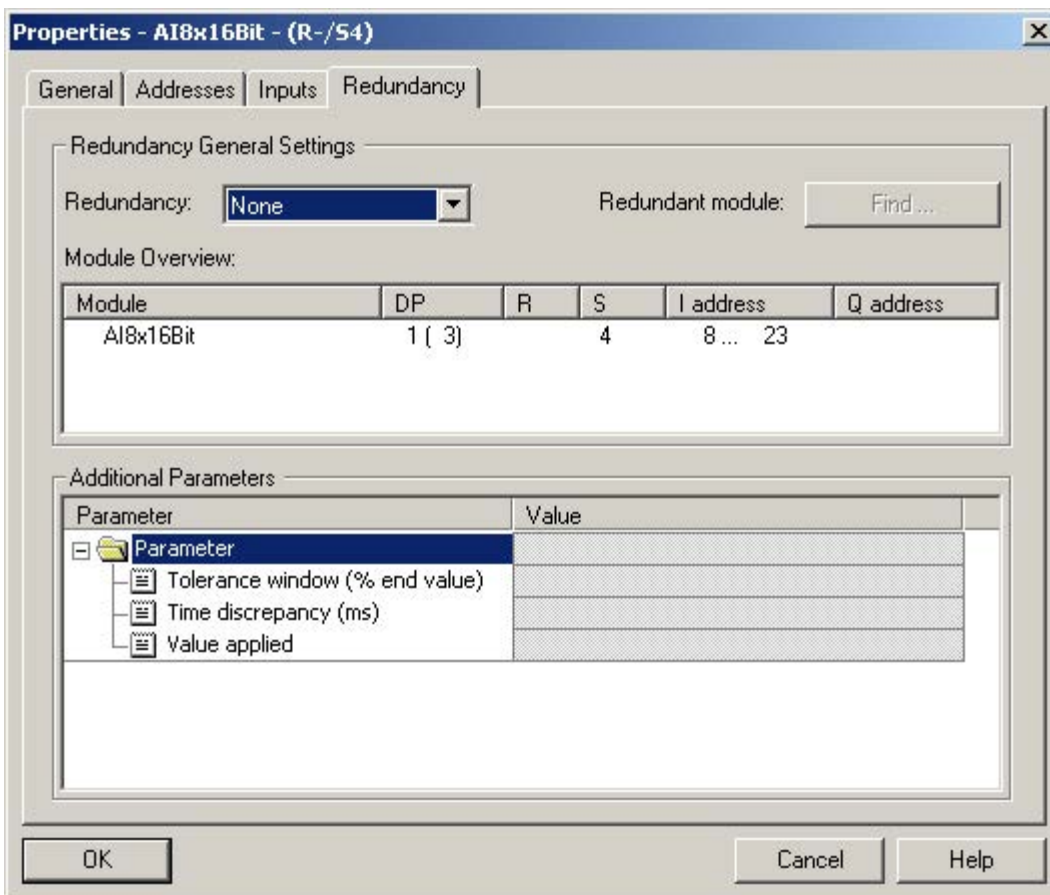

10 6-Channel F Analog Input HART MTA

Part No. 6ES7650-1AH61-5XX0

10.1 Description

This section contains installation information and requirements for the Siemens Marshalled Termination Assembly (MTA) (6ES7650-1AH61-5XX0) designed to interface with the Siemens ET 200M 6-Channel F Analog Input HART Module (6ES7 336-4GE00-0AB0).

10.2 Features

The following features have been incorporated into this MTA:

- Redundant power connections
- LED indication of redundant power supply condition
- Power monitor plug-in available (optional)
- LED indication of power supply to the field device on an individual channel basis
- Per channel fusing of field power
- Dual connectors for redundant I/O Module operation
- Diode boards are pluggable for maintenance
- Per module power fusing
- Shield connections available for channel cabling
- Ground stud for connecting shield to earth ground
- Power input and field terminations are pluggable for easy maintenance
- Connectivity for HART Handheld Terminal (HHT) per channel

10.3 Operation

The Fail-Safe Analog Input HART (FAIH) MTA consists of the

- Main board
- Two diode boards

The diode board marked **1** (MLFB 6ES7650-1BC51-0XX0 or 6ES7650-1BC50-0XX0) uses 6.2 VDC zener diodes. The diode board marked **2** (MLFB 6ES7650-1BB51-0XX0 or 6ES7650-1BB50-0XX0) uses 5.6 VDC zener diodes. The two diode boards make maintenance of redundant modules possible. The diode boards plug in to the main board and can be removed for testing and maintenance without affecting operation of the input module.

Power is supplied via the two removable power connectors which are retained by screws and marked **L+A, MA**, and **L+B, MB**. Each has a LED to indicate the presence of voltage over 15 VDC. The LEDs are marked **A POWER** and **B POWER**. There is also a connector (**J3**) for a Power Monitor board used to indicate the presence of both A and B power. See Section 19, *Power Monitor Board* (6ES7650-1BA02-0XX0).

Incoming power from **A** and **B** is diode OR'd, in **CR106**, to provide the MTA and the module power from either input source. The output from **CR106** is sent to the I/O modules via the module fuses and to the channels via the channel fuses. Module Fuse 1 (**F100**) supplies the I/O Module plugged into **J1** and Module Fuse 2 (**F101**) supplies power to the I/O Module plugged into **J2**.

Each channel has an LED to indicate the presence of power and the fuse status. If there is no power or the fuse is open, then the LED remains off. If there is power and the fuse is good, then the LED is illuminated.

Field Terminals, Channel + (**Ix+**), Channel – (**Ix-**), Sensor power (**PWRx**) and Shield (**SHx**), connect to the field devices. **PWRx** is the +24 VDC power feed and is fused on a channel-by-channel basis. The field termination connector is removable for ease of wiring maintenance and is retained by friction.

For redundant I/O Modules, the **Ix-** connects to the I/O modules input via **J1** and **J2**. If both modules are present, then the diodes on boards **1** and **2** are passive, but ensure that if either module is removed for maintenance, the input signals to the remaining module are not interrupted. Redundant operation uses the MTA, two zener diode boards, and two FAI modules. A simplified diagram of redundant use of the FAI module and MTA is shown in Figure 10–1

For a non-redundant I/O module, the **Ix-** connects to the I/O module input via the diodes on Diode Board **1**. The diodes on Diode Board **1** conduct the signal to the non-redundant module plugged into **J2**. In this case the diodes on board **2** are passive. Non-redundant modules could be plugged into **J1** or **J2**. Non-redundant operation uses the MTA, two Zener Diode Boards, and the FAI module. A simplified diagram of Non-redundant use of the FAI module and MTA is shown in Figure 10–2.

Note

Use of the FAIH MTA for non-redundant operation requires that the FAI I/O to MTA cable be installed into **J2** on the MTA.

Figure 10-1 Redundant FAIH Interface

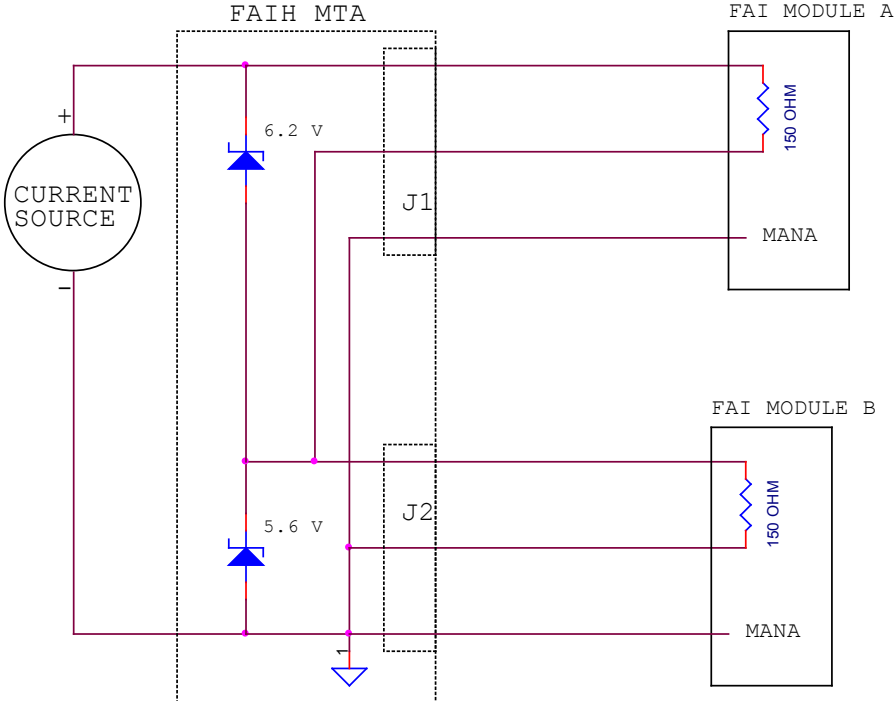
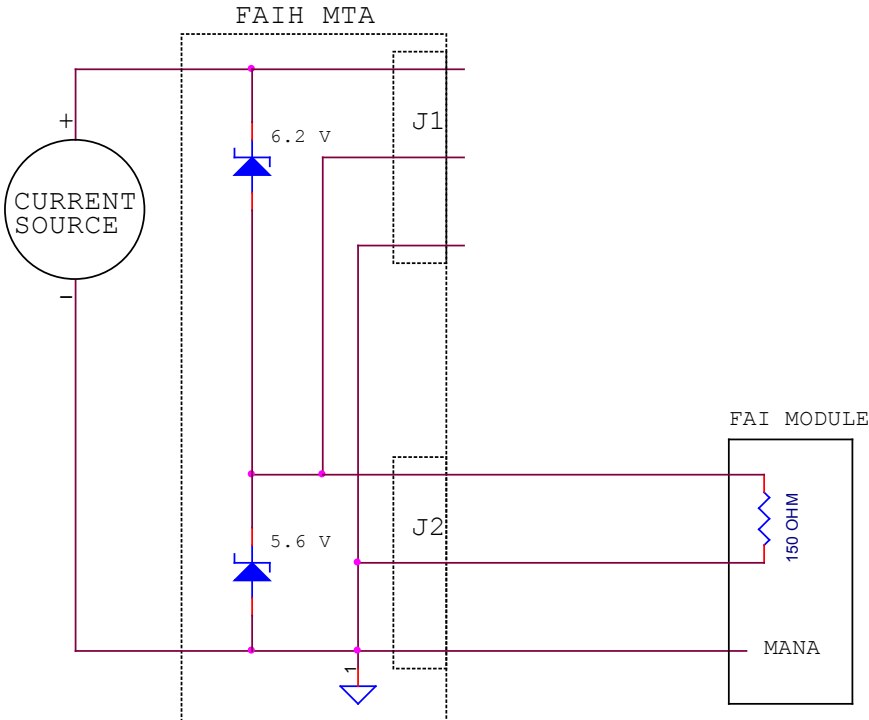

Figure 10-2 Non-Redundant FAI Interface



10.4 Installation Requirements

See Section 2, *Installation*, before performing any installation and observe all warnings

A common interconnecting cable (6ES7922-3BD00-0AU0 or 6ES7922-3BJ00-0AU0), supporting six analog input channels, interconnects the analog input termination assembly to the 6-channel analog input module (6ES7 336-4GE00-0AB0).

It may be necessary to modify the printed circuit board as follows:

To disconnect the interconnecting cable shield from ground at the MTA only, cut and remove the shield disconnect jumper, **W100** and **W101**, for the associated cable.

Note

To separate channel input low from power supply common, cut and remove the jumper **W200**. This will provide isolation between the all the inputs and power return.

10.5 Maintenance

See Section 3, *Maintenance*, before performing any maintenance and observe all warnings.

Under normal operation, the **A/B Power LED**, the **Module 1/2 Fuse LED**, and all the **Channel Fuse LEDs** are on. If all are off, check the power supply to MTA. If the **A/B Power LED** is off, check the power supply to the MTA. If the **Module 1/2 Fuse LED** is off, check and replace the module fuse. If the **Channel Fuse LED** is off, check the channel fuse and replace as necessary.

Periodically the diode boards should be tested to verify that the zener diodes will operate correctly. Testing consists of connecting a DC power supply with a current-limiting series resistor across each diode. The power supply should provide ≤ 20 mA at 15 to 24 VDC. The voltage measured across the zener diodes on the #1 board should be the device's nominal specification of 6.2 VDC and on the #2 board should be the device's nominal specification of 5.6 VDC.

Note

Correct power down and power up of the FAI module is crucial to the proper operation of the system. The proven procedure for removal and re-installation of the FAI module is as follows:

1. Remove the MTA-I/O cable connector from the FAI module.
 2. Remove the FAI module from the backplane.
 3. Perform FAI module maintenance as required.
 4. Reinstall the FAI module into the backplane.
 5. Reinstall the MTA-I/O cable connector onto the FAI module.
-

10.6 6-Channel F Analog Input HART Marshallled Termination Assembly

Figure 10–3 shows the basic parts of the 6-Channel F Analog Input HART MTA.

Figure 10–3 6-Channel F Analog Input HART Marshallled Termination Assembly (6ES7650-1AH61-5XX0)

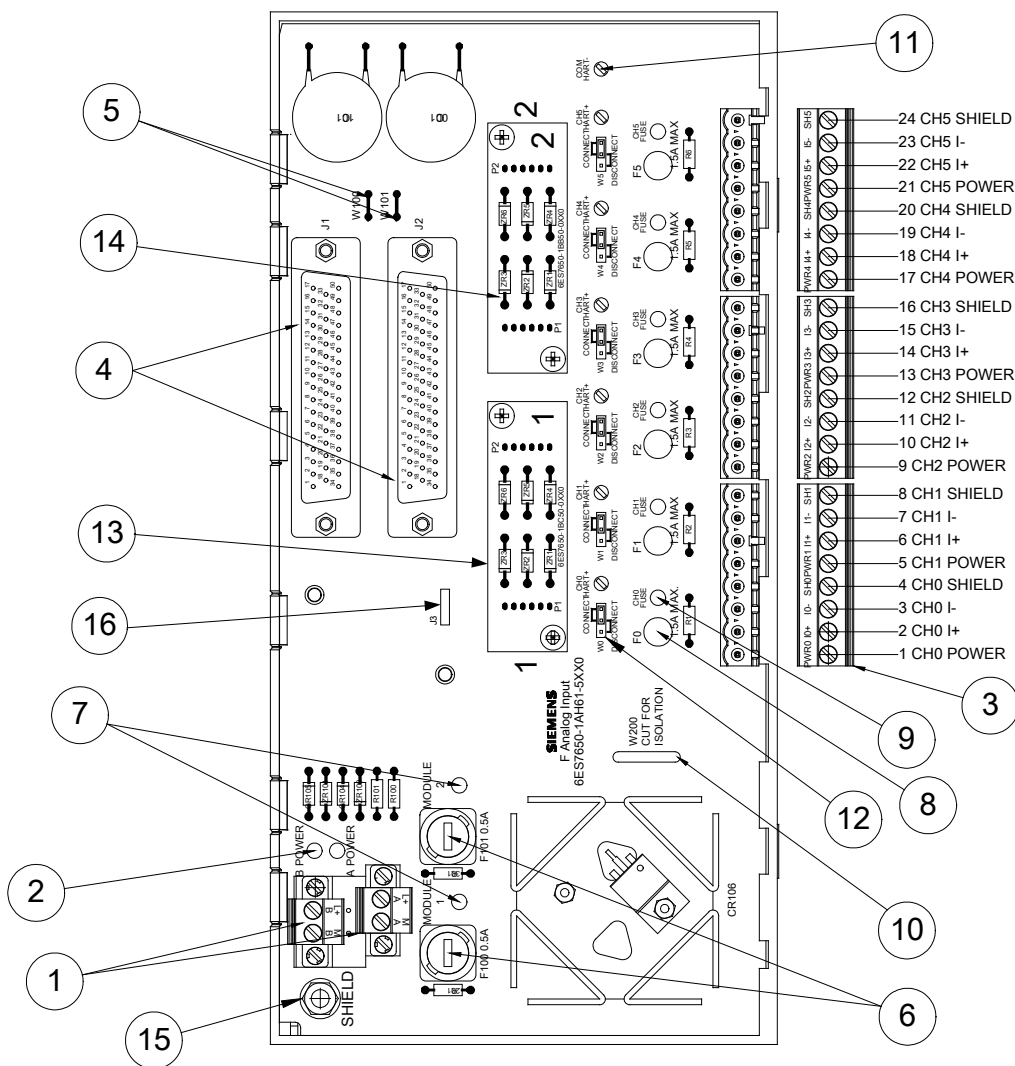

Key to numbered items in Figure 10-3:	
Item	Description
1	Input power connections
2	Input power indicators
3	Field wiring connections
4	I/O module connections
5	Shield disconnect jumper (W100 & W101)
6	Module power fuses
7	Module power fuse indicators
8	Channel power fuse (1 of 6)
9	Channel power fuse indicator (1 of 6)
10	Input isolation Jumper (W200)
11	HART connectivity terminals (1 of 7)
12	Channel Input Disconnect Jumper (W0 – W5)
13	6.2V Zener Diode Boards (1)
14	5.6V Zener Diode Boards (2)
15	Shield Ground Stud for connecting to earth ground
16	Connector for Power Monitor Board

10.7 Technical Specifications

Technical Specifications for 6-Channel F Analog Input HART MTA (6ES7650-1AH61-5XX0)	
Dimensions - See Section 1, Figure 1.3, Long Version	
Mounting	
DIN Rail	35mm (deep top hat style)
Power Input	
Voltage Input for Single or Redundant Feed	21.6 to 28.8 VDC
Current Consumption (nominal ratings; all channels connected)	
Inrush	9.368 A maximum (Includes 9.000 A for transmitter inrush)
Normal	0.5 A maximum
Terminal Block Wire Sizes	TB100 & TB101
Wire Size – US	24 – 14 gauge AWG
Wire Size – Metric	0,205 – 2,08 mm sq.
Power Supply Specifications	See Module Specs
Fuse Ratings	
Individual channel - Normal	0.1 A Fast blow (Littelfuse P/N: 273.100) (Siemens Spare P/N: A5E01568889)
Individual channel – Optional - Recommended for 4 wire transmitters	1.5 A Fast blow (Littelfuse P/N: 273 01.5) (Siemens Spare P/N: A5E01568886)
Module Power	0.5 A (Bussmann P/N: GMA-0.5A) (Siemens Spare P/N: A5E01568885)
Indicators	
Input Power	Green LED on when input power available
Module Power	Green LED on when module power available
Channel Power	Green LED on when sensor power available
Field Terminal Block Wire Sizes TB1 – TB3	
Wire Size – US	24 – 14 gauge AWG
Wire Size – Metric	0,205 – 2,08 mm sq.
Environmental	
Ambient Temperature	-25C to +60C
Humidity	5% to 95% Non-condensing
Approvals	
MTA Agency Approvals	See Preface section, Approvals Table
Max achievable Safety Integrity Level in safety mode	
In Accordance with IEC 61508	SIL 3
Fail-safe performance characteristics	
Low demand mode (average probability of failure on demand) per channel	PFDavg <1E-4 @ 60C
High Demand continuous mode (probability of dangerous failure per hour per channel)	PFH < 1E-9
Proof-test interval	20 years

Note

When using a 1.5A channel fuse it is possible that one or more of the zener diodes on the two Zener Diode Boards may be damaged in the event of a short circuit in the field. It is recommended that the diode boards be tested or replaced in the event a 1.5A channel fuse opens.

Note

Fuses are available as spare parts from Siemens.

Fuse information can be found at:

<http://www.littelfuse.com>

<http://www.bussmann.com>

10.8 Changes to the Technical Specifications for 6-Channel F ANALOG INPUT HART Module (6ES7 336-4GE00-0AB0)

This section contains changes to the I/O module specifications when it is used with the MTA.

Changes for 6-Channel F Analog Input HART MTA (6ES7650-1AH61-5XX0)	
Transmitter Connections	Only 1 transmitter can be connected to a channel.
Output voltage for 2 wire transducer and cable with 22 mA transducer current	14 V @ 24 V Supply*
Fail-safe Performance Characteristics	Adds a dangerous undetected failure rate (2.4 FIT for 6 channels) to the FAI module in any configuration.
Sensor Supply	The FAI module internal sensor supply outputs are not used when using the FAIH MTA.
Protection against short circuit with external sensor supply	No external fuse required. The FAIH MTA limits current.
* If the output voltage is not sufficient for a 2 wire transmitter, safety barrier and field wiring, it is recommended that a 4 wire transmitter be used.	

10.9 Typical Transmitter Connection to Field Terminals

Figure 10-4 Transmitter Connection to Field Terminals

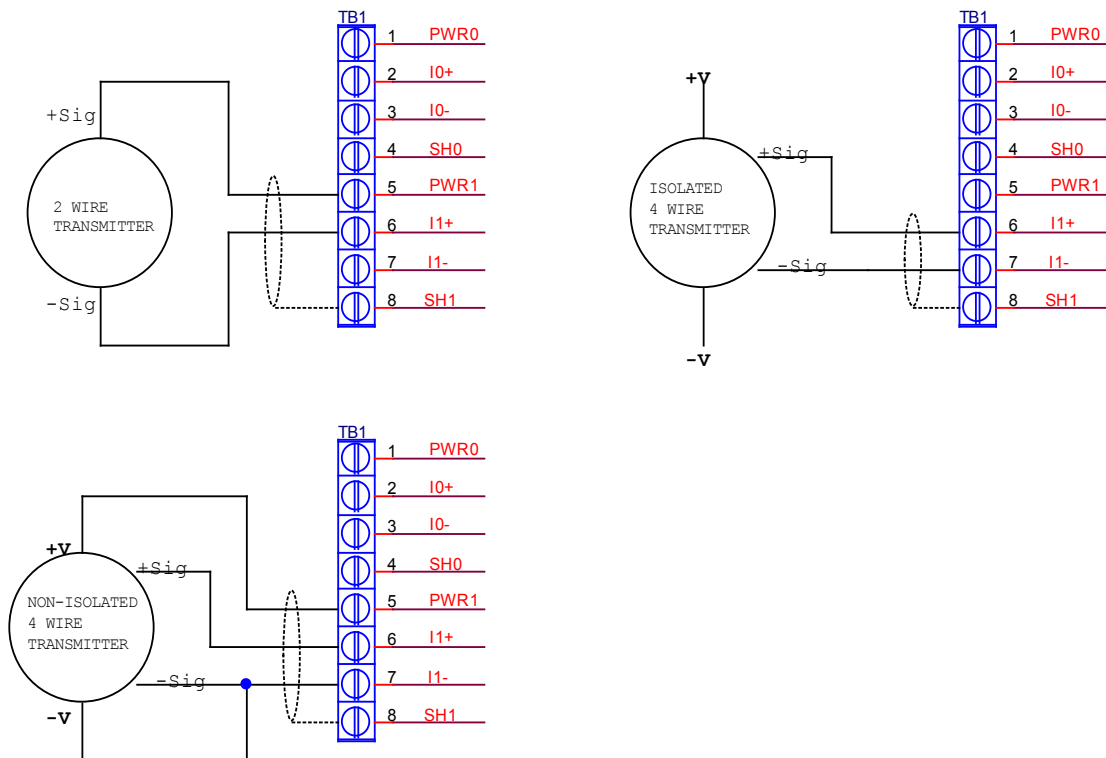

10.10 Hardware Configuration

For hardware configuration refer to the manual *S7-300 Automation System Fail-Safe Signal Modules* (document number A5E00085586).

10.11 Technical Specifications for 6-Channel F ANALOG INPUT HART Module (6ES7 336-4GE00-0AB0)

Note

For a complete functional description and the most current technical specifications for this module, refer to the manual *S7-300 Automation System Fail-Safe Signal Modules* (document number A5E00085586).

10.12 Zener Diode Boards

Part No. 6ES7650-1BB51-0XX0 or 6ES7650-1BB50-0XX0 and 6ES7650-1BC51-0XX0 or 6ES7650-1BC50-0XX0

10.12.1 Description

This section contains installation information and requirements for the two Siemens Zener Diode Boards. The 6.2 VDC (6ES7650-1BC51-0XX0 or 6ES7650-1BC50-0XX0) and the 5.6 VDC (6ES7650-1BB51-0XX0 or 6ES7650-1BB50-0XX0) are used on the ET200M Marshalled Termination Assembly (MTA) (6ES7650-1AH51-5XX0 or 6ES7650-1AH50-5XX0) designed to interface with the Siemens ET 200M 6-Channel F Analog Input HART Module (6ES7 336-4GE00-0AB0).

Note: The two part numbers for the 5.6 V Diode Board are interchangeable. The two part numbers for the 6.2 V Diode Board are also interchangeable. Do not interchange 5.6 V Diode Boards with 6.2 V Diode Boards.

10.12.2 Operation

The 6.2 VDC and the 5.6 VDC Zener Diode Board allows proper operation of the 6 Channel Failsafe Analog Input Module with the MTA. Diodes are placed in parallel with the module inputs. One diode spans one channel on one module; therefore, one diode board handles one module. The diodes are normally not conducting but when a module or the interconnecting cable is removed; the diodes conduct and keep the current constant for the other module. In a redundant system none of the diodes normally conducts, but in a non-redundant system one is always conducting. Figure 10–5 shows a simplified schematic.

Figure 10-5 Diode Board Interfaces

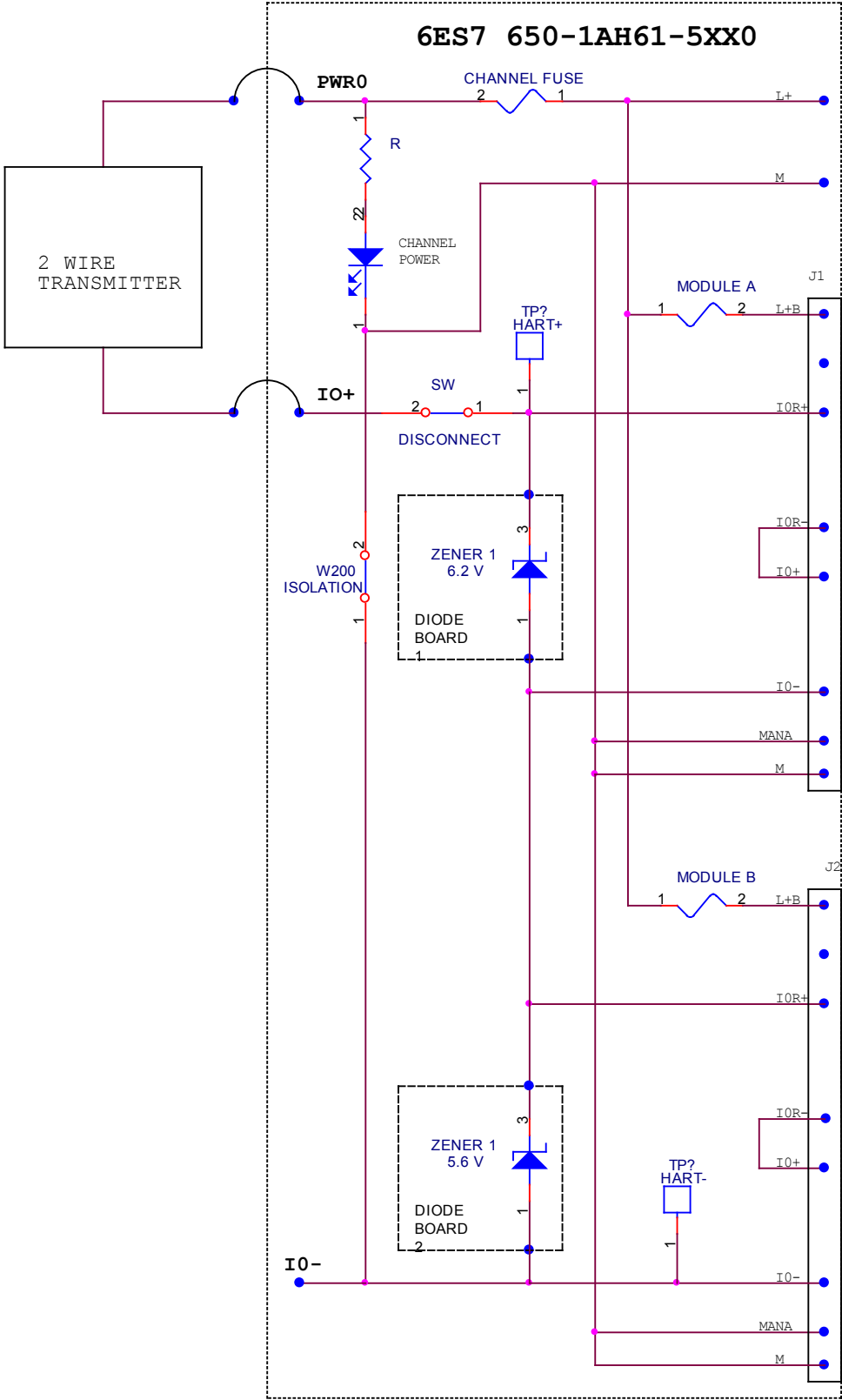

10.12.3 Installation Requirements

See Section 2, *Installation*, before performing any installation and observe all warnings

The 6.2 VDC Zener Diode Board, marked **1** is plugged into **J100** and **J101** on the FAI MTA. It is mechanically held down by two captive screws and standoffs. See Figure 10–7.

The 5.6 VDC Zener Diode Board, marked **2** is plugged into **J200** and **J201** on the FAI MTA. It is mechanically held down by two captive screws and standoffs. See Figure 10–8.

10.12.4 Maintenance

See Section 3, *Maintenance*, before performing any maintenance and observe all warnings

Under normal operation, the diodes on the diode board do not conduct. Periodic maintenance of the FAI modules requires that the diode boards operate correctly, so the diode boards should be tested before one of the redundant modules is removed from service.

Figure 10-6 5.6V Diode Board Test Setup

ZENER DIODE BOARD TEST SETUP

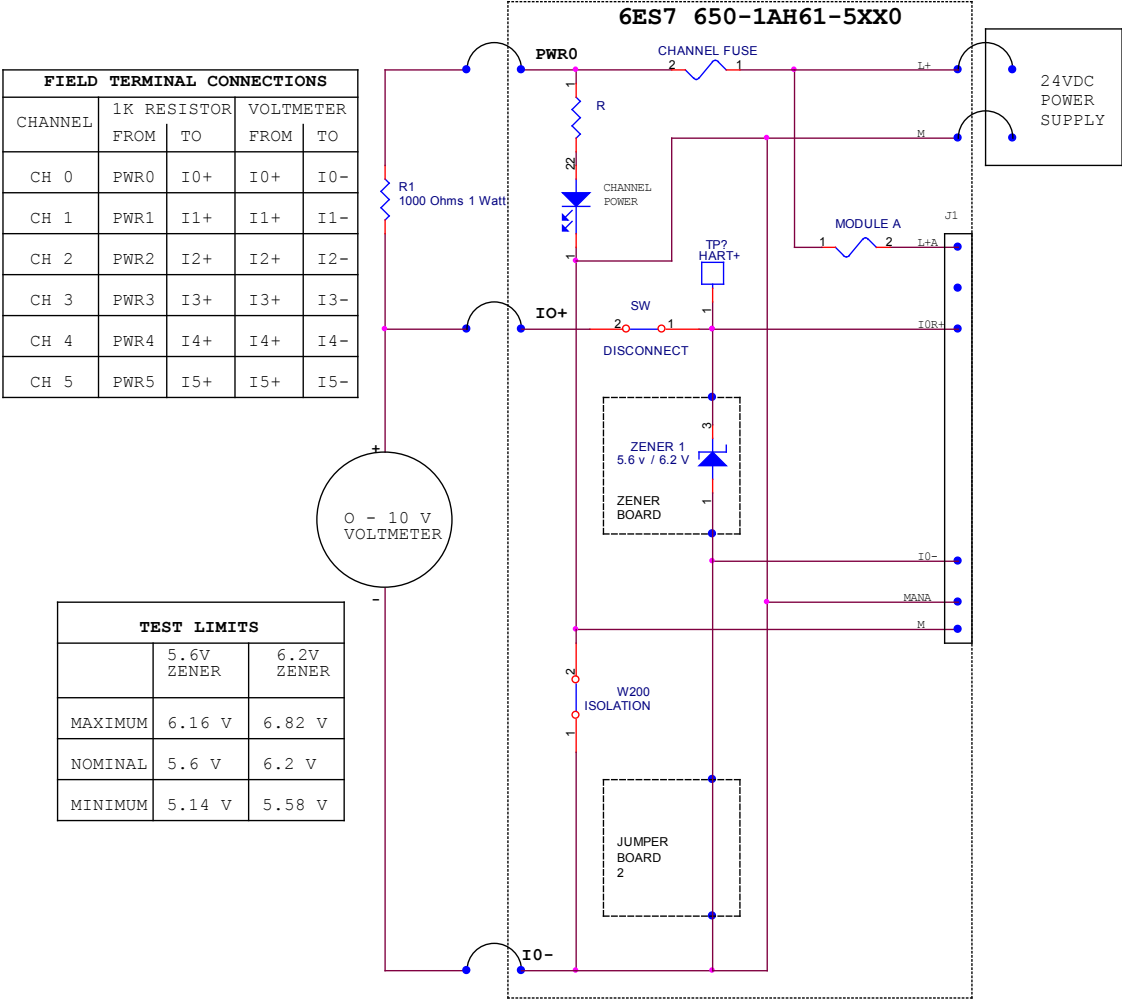

10.13 Diode Board Assembly

The two figures below show the basic parts of the diode boards.

Figure 10–7 6.2V Diode Board Assembly

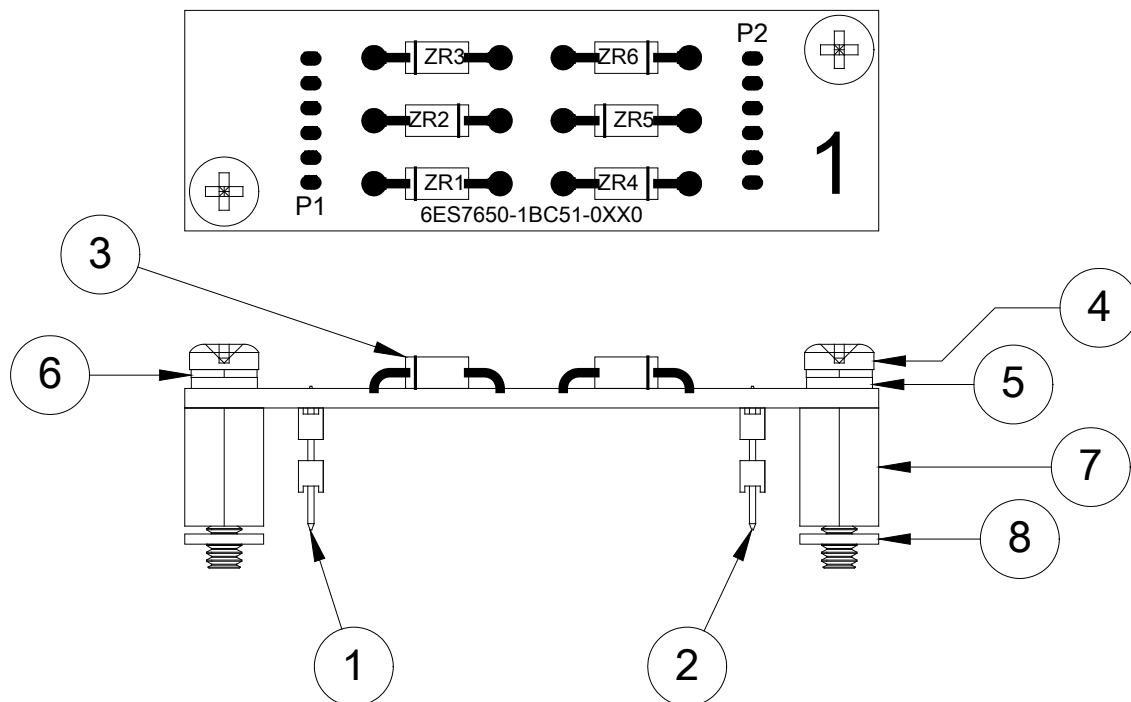

Key to numbered items in Figure 10–7:	
Item	Description
1	P1
2	P2
3	6.2V Zener Diode (1 of 6)
4	Screw
5	Flat washer
6	Lock Washer
7	Standoff
8	Retaining Washer

Figure 10-8 5.6V Diode Board Assembly

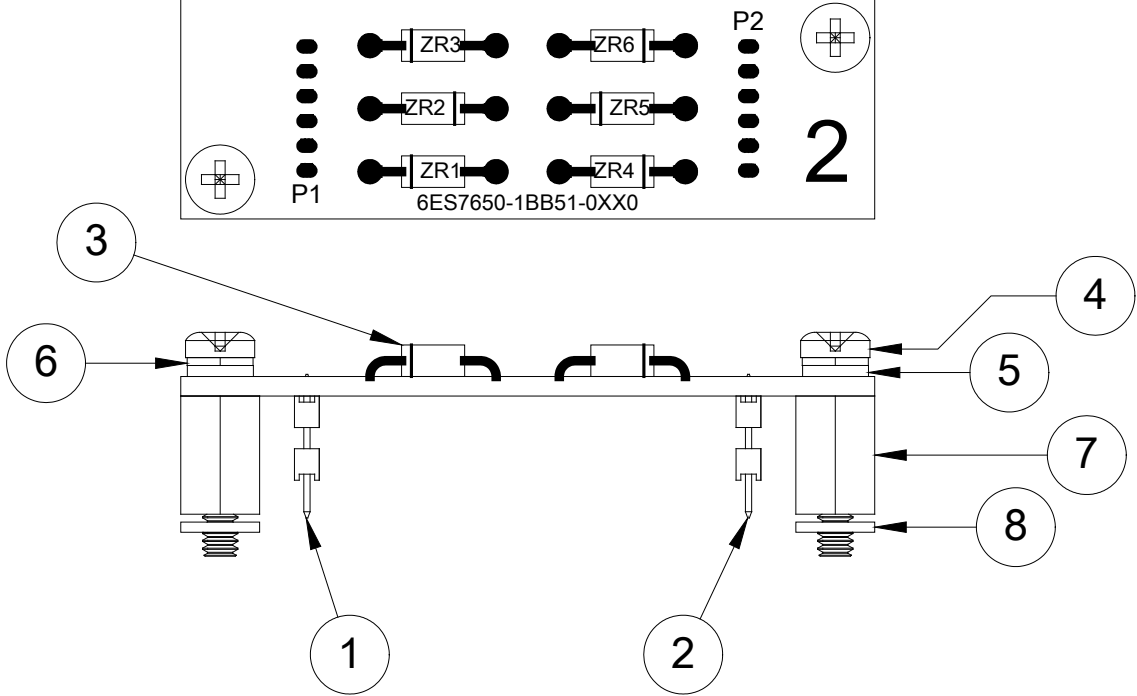

Key to numbered items in Figure 10-8:	
Item	Description
1	P1
2	P2
3	5.6V Zener Diode (1 of 6)
4	Screw
5	Flat washer
6	Lock Washer
7	Standoff
8	Retaining Washer

10.14 Input Sharing

10.14.1 Description

This section contains information and requirements for input sharing between a Failsafe Analog Input module (6ES7 336-4GE00-0AB0) and a Standard Analog Input Module (6ES7 331-7NF00-0AB0, E-Stand 5 or higher), using the Siemens FAIH Marshallled Termination Assembly (MTA) (6ES7650-1AH61-5XX0 and the Siemens AI Marshallled Termination Assembly (MTA) (6ES7650-1AA51-2XX0 or 6ES7650-1AA50-2XX0).

10.14.2 Purpose

Input sharing allows the transmitter signal to be distributed to both the Fail-Safe Analog Input Module and the Standard Analog Input Module. Both systems will then receive the same input data.

Figure 10–9 FAIH SAI Input Sharing

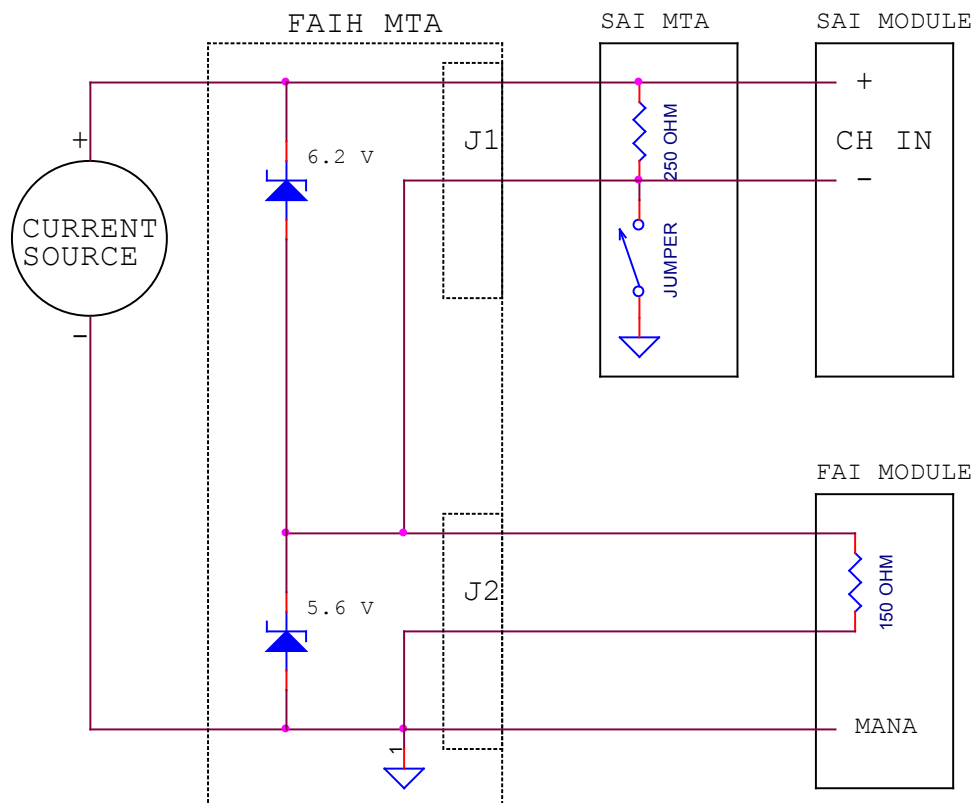

10.14.3 Operation

The signal source is connected to the FAIH MTA in the normal manner. The cable plugged into J1 is wired from IxR+ to Ix+ on TBy of the Standard Analog Input (SAI) MTA (6ES7650-1AA51-2XX0 or 6ES7650-1AA50-2XX0) and the Ix- pin to Ix- on TBy of the SAI MTA. The SAI MTA input jumpers (W0 – W7) are set for current mode and the isolation jumpers (W8 – W15) are cut for each channel connected to the FAIH MTA. The SAI Module is connected to the SAI MTA using the standard cable. See Table 1-2.

10.14.4 FAIH MTA to SAI MTA Cable

The FAIH MTA to SAI MTA Input Sharing cable uses only 13 conductors. The FAIH Channel 0 to Channel 5 input signals have been mapped to Channels 0 through 5 on the SAI MTA. Channels 6 & 7 of the SAI can be used for other inputs. The cable connections can be seen in the table below.

The FAIH MTA to SAI MTA Input Sharing cable is custom manufactured on a project basis. See the project manager to for more information.

The assembly view of the cable can be seen in Figure 10–10.

Table 10–1 FAIH MTA to SAI MTA Cable

FAIH Channel	FAIH MTA Signal	FAIH MTA D50M Pin	SAI MTA Field Terminal	SAI MTA Signal	SAI Channel
CH 0+	I0R+	19	TB1 PIN 2	I0+	CH 0+
CH 0-	I0-	27	TB1 PIN 3	I0-	CH 0-
CH 1+	I1R+	20	TB1 PIN 6	I1+	CH 1+
CH 1-	I1-	28	TB1 PIN 7	I1-	CH 1-
CH 2+	I2R+	38	TB1 PIN 10	I2+	CH 2+
CH 2-	I2-	46	TB1 PIN 11	I2-	CH 2-
CH 3+	I3R+	23	TB1 PIN 14	I3+	CH 3+
CH 3-	I3-	47	TB1 PIN 15	I3-	CH 3-
CH 4+	I4R+	40	TB2 PIN 2	I4+	CH 4+
CH 4-	I4-	15	TB2 PIN 3	I4-	CH 4-
CH 5+	I5R+	8	TB2 PIN 6	I5+	CH 5+
CH 5-	I5-	16,17, 32	TB2 PIN 7	I5-	CH 5-
	Shield	Shield	TB1 PIN 4 ⁶	SH0	

⁶ The shield connection to the SAI MTA is optional and should be investigated for safe operation before use

Figure 10–10 FAIH MTA to SAI MTA Interconnecting Cable

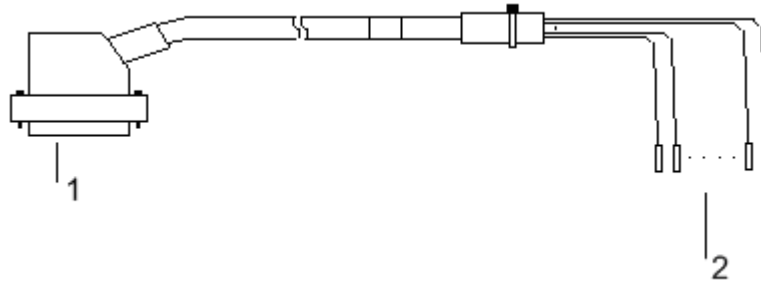

Key to numbered items in Figure 10–10:

Item	Part Name
1	50-PIN FEMALE sub-D connector
2	Wires with crimped pins

10.14.5 Hardware Configuration

FAI: Redundancy not supported. The HW configuration should be setup for Non-redundant operation.

SAI: The SAI MTA supports redundancy for the Standard Modules and redundant modules can be used, as selected by the user. See section 4.10.

Addresses

FAI: Input address and process image should be set to the user preferences.

SAI: Input address and process image should be set to the user preferences. See section 4.10.

Inputs

FAI: Set to user preferences.

SAI: Under the **Inputs** tab the **Measuring Type** should be set to **4DMU** (current) with **Measuring Range** set to **4..20 mA**. All other settings are up to the user. See section 4.10.

Because the FAI has only 6 inputs the SAI will only use 6 inputs for the sharing operation. The other two inputs can be used for other analog signals.

Redundancy

FAI: Redundancy not supported. The HW configuration should be setup for non-redundant operation.

SAI: The SAI MTA supports redundant and non-redundant operation. See section 4.10.

11 6-Channel F Analog Input HART MTA

Part No. 6ES7650-1AH62-5XX0

11.1 Description

This section contains installation information and requirements for the Siemens Marshalled Termination Assembly (MTA) (6ES7650-1AH62-5XX0) designed to interface with the Siemens ET 200M 6-Channel F Analog Input HART Module (6ES7336-4GE00-0AB0).

11.2 Features

The following features have been incorporated into this MTA:

- Redundant power connections
- LED indication of redundant power supply condition
- LED indication of reverse polarity
- Power monitor output
- short circuit proofed 2-wire transducer supply per channel
- Dual connectors for redundant I/O Module operation
- Per module power fusing
- Shield connections available for channel cabling
- Ground stud for connecting shield to earth ground
- Connectivity for HART Handheld Terminal (HHT) per channel

11.3 Modification vs 6-Channel F Analog Input MTA 6ES7650-1AH61-5XX0

- electronically short circuit proofed 2-wire transducer supply
- no power supply supported for 4-wire transducer
- Power Monitor System onboard
- no changeable diode boards
- one piece connectors
- housing short version

11.4 Operation

Power is supplied via the two power connectors which are marked **L/A+**, **M/A**, and **L/B+**, **M/B**. Each has a green LED to indicate the presence of voltage over 15 VDC. The case of polarity reversal of the power supply is indicated by the LEDs illuminating red. The LEDs are marked **A POWER** and **B POWER**.

Incoming power from **A** and **B** is diode OR'd to provide the MTA and the module power from either input source. The output from the diodes is sent to the I/O modules via the module fuses and to the channels via the transducer supplies. Module Fuse F110 (**MODULE 1**) supplies the I/O Module plugged into **MODULE 1** and Module Fuse F160 (**MODULE 2**) supplies power to the I/O Module plugged into **MODULE 2**.

An onboard Power Monitor System (PMS) is used to provide an isolated dry contact when redundant power is supplied to MTAs. Only when power is supplied to both power inputs the output contacts **1** and **2** are closed. The Power Monitor System is designed to detect only the presence or absence of power. It is not designed to detect supply voltage which is outside the specification threshold.

Field Terminals, Channel + (**Ix+**), Channel – (**Ix-**), Transducer power (**PWx**) and Shield (**SHx**), connect to the field devices. **PWx** is the +24 VDC power feed for supplying 2-wire transducer and is short circuit proofed on a channel-by-channel basis.

For redundant I/O Modules, the **Ix+/-** connects to the I/O modules input via **MODULE 1** and **MODULE 2**. If both modules are present, then the Zener-diodes which are in parallel to the measuring inputs are passive, but ensure that if one module is removed for maintenance, the input signals to the remaining module are not interrupted. Redundant operation uses the MTA and two FAI modules. A simplified diagram of redundant use of the FAI module and MTA is shown in Figure 10–1

For a non-redundant I/O module, the **Ix+/-** connects to the I/O module input via the upper diodes. These diodes conduct the signal to the non-redundant module plugged into **MODULE 2**. In this case the lower diodes are passive. Non-redundant modules could be plugged into **MODULE 1** or **MODULE 2**. Non-redundant operation uses the MTA and one FAI module. A simplified diagram of Non-redundant use of the FAI module and MTA is shown in Figure 10–2.

Figure 11-1 Redundant FAIH Interface

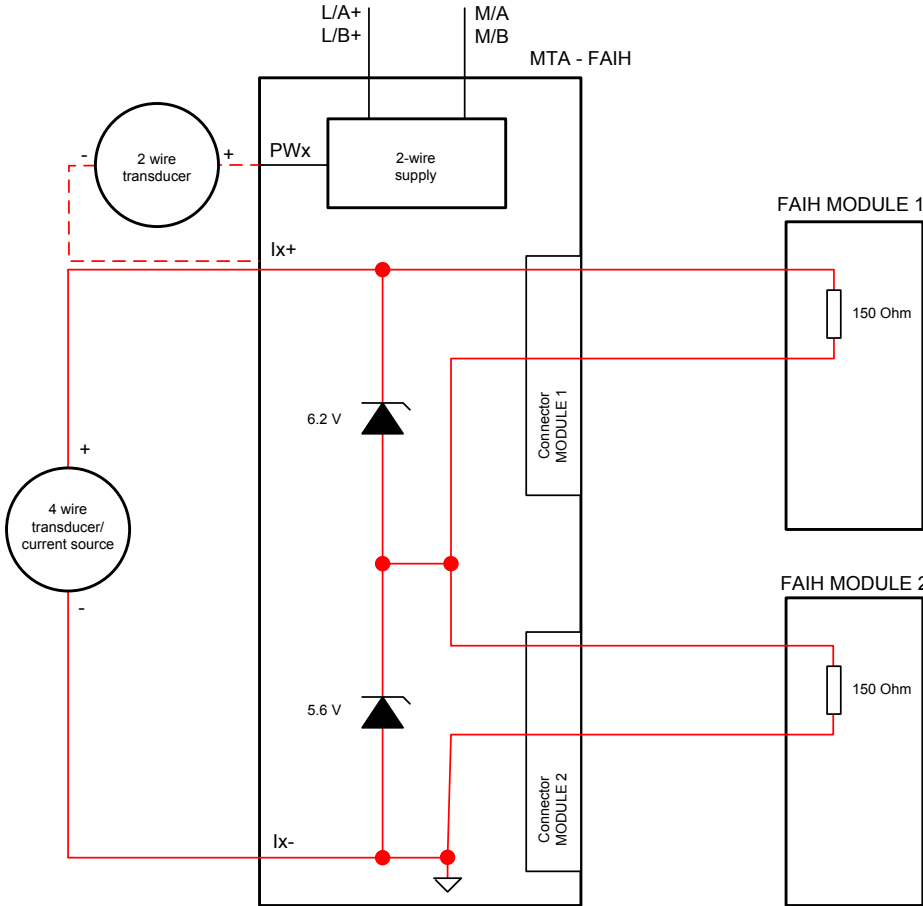
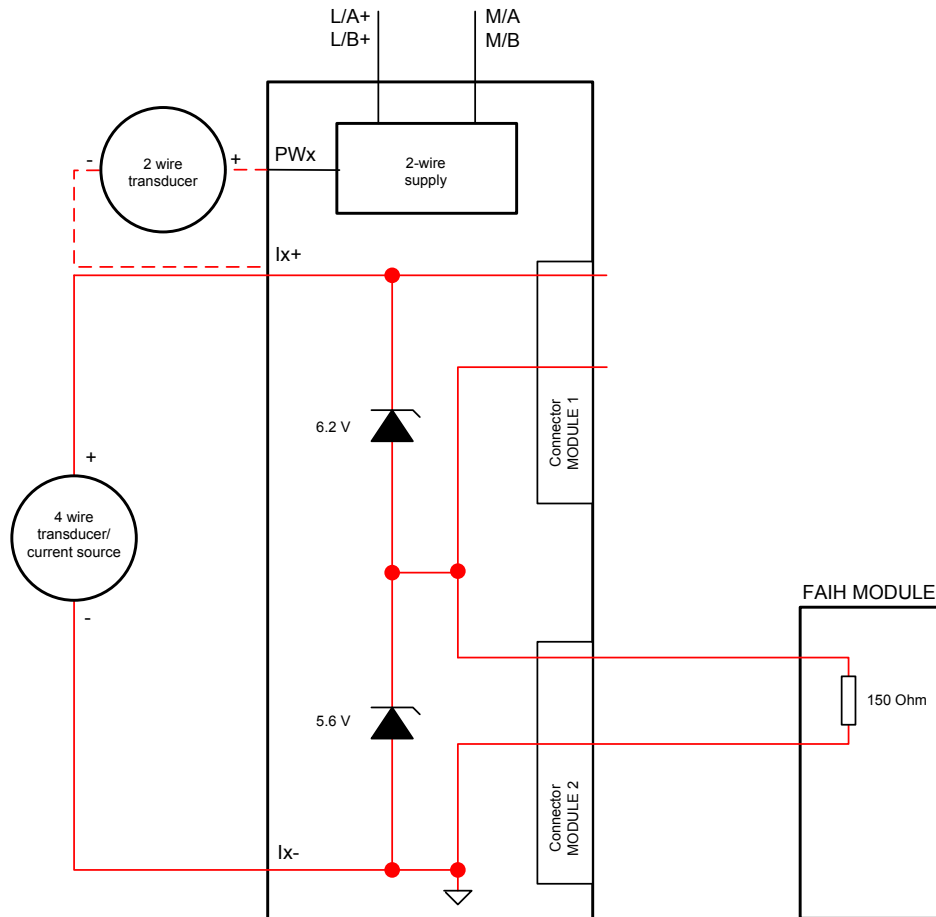

Figure 11-2 Non-Redundant FAI Interface



11.5 Installation Requirements

See Section *Installation*, before performing any installation and observe all warnings.

A common interconnecting cable (6ES7922-3BD00-0AU0 or 6ES7922-3BJ00-0AU0), supporting six analog input channels, interconnects the analog input termination assembly to the 6-channel analog input module (6ES7336-4GE00-0AB0).

It may be necessary to modify the printed circuit board as follows:

To disconnect the interconnecting cable shield from ground at the MTA only, cut and remove the shield disconnect jumper, **X100** and **X101**, for the associated cable.

Note

To separate channel input low from power supply common, cut and remove the jumper **X300**. This will provide isolation between all the inputs and power return.

11.6 Maintenance

See Section *Maintenance* before performing any maintenance and observe all warnings.

Under normal operation, the **A/B Power LED** and the **Module 1/2 Fuse LED** are on. If all are off, check the power supply to MTA. If the **A/B Power LED** is off, check the power supply to the MTA. If the **Module 1/2 Fuse LED** is off, check the module fuse and replace as necessary.

Note

Correct power down and power up of the FAI module is crucial to the proper operation of the system. The proven procedure for removal and re-installation of the FAI module is as follows:

6. Remove the MTA-I/O cable connector from the FAI module.
 7. Remove the FAI module from the backplane.
 8. Perform FAI module maintenance as required.
 9. Reinstall the FAI module into the backplane.
 10. Reinstall the MTA-I/O cable connector onto the FAI module.
-

11.6.1 Maintenance for 2-wire transducer supply

The power supply for 2-wire transducer is individually short circuit proofed for each channel. In case of a external short circuit, provided by a faulty wiring, the current is limited up to 40 mA.

The power supply circuit works in redundant mode. By this reason also in case of a internal component error the normal current range (<24mA) will be supported.

Nevertheless a periodic check of the 2-wire power supply will be commended.

Please notice::

This check will disable the measurement on both conducted FAIH- modules.
During test both modules will provide a broken wire diagnostic.

Figure 11-3 2-wire transducer supply test setup

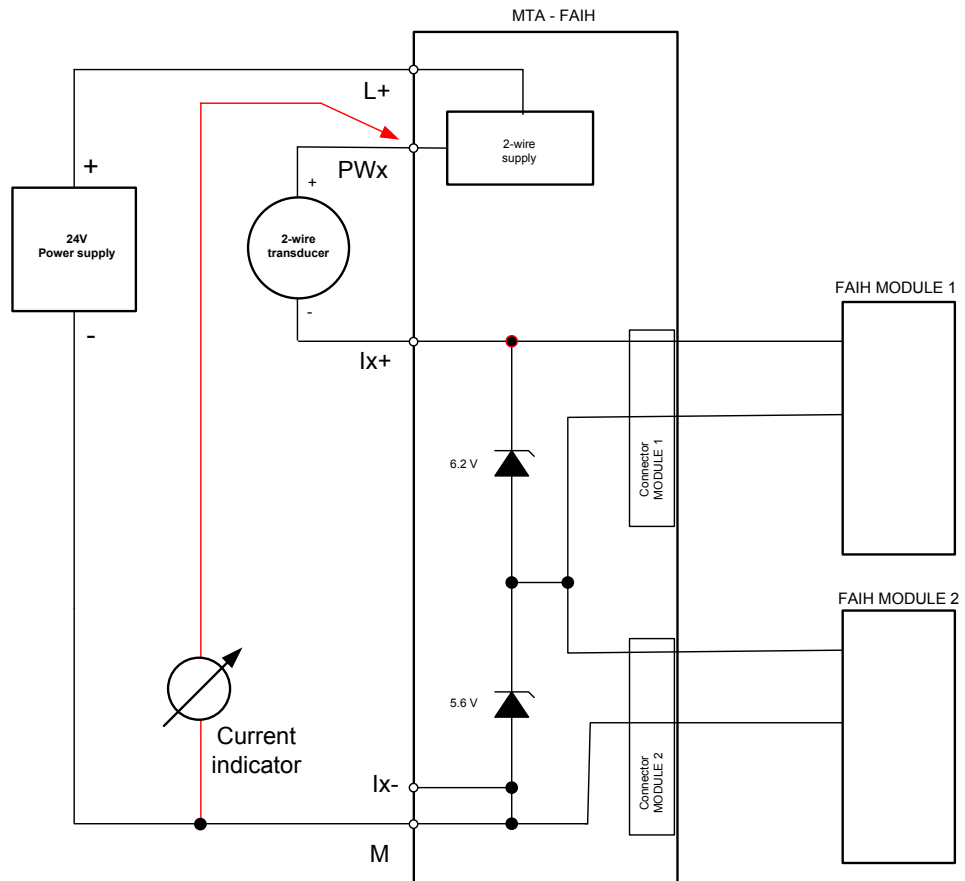

The correct function of the 2-wire transducer supply can be checked without modifying the wiring.

A DC current indicator connected with the minus connector to ground (M/A or M/B) contacts PW0 ... PW5.

Measured current must be 35mA ... 40mA.

In case a smaller value will be measured the MTA has become defect.

11.6.2 6-Channel F Analog Input HART Marshalled Termination Assembly

Figure 10–3 shows the basic parts of the 6-Channel F Analog Input HART MTA.

Figure 11–4 6-Channel F Analog Input HART Marshalled Termination Assembly (6ES7650-1AH62-5XX0)

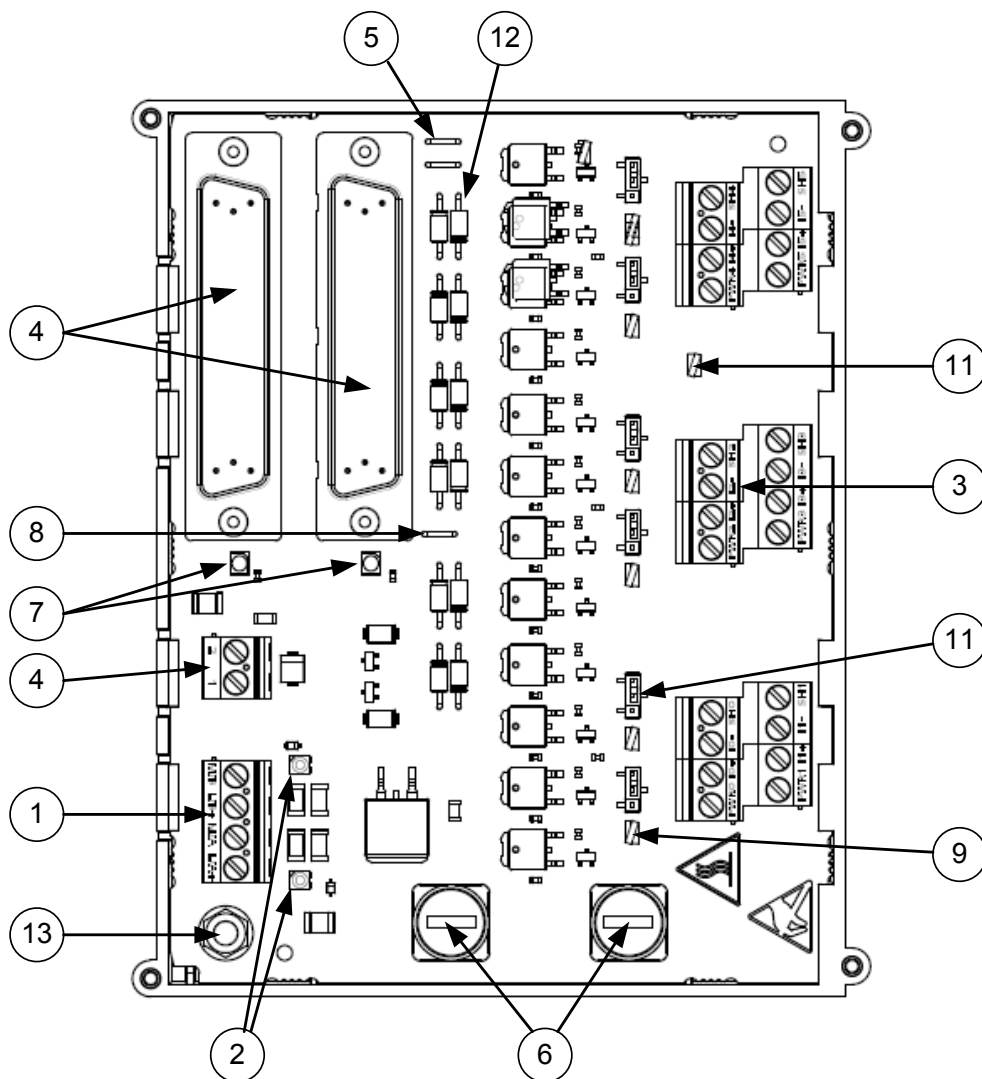

Key to numbered items in Figure 10-3:	
Item	Description
1	Input power connections (L/A+, M/A, L/B+, M/B)
2	Input power indicators (A POWER, B POWER)
3	Field wiring connections
4	Output Power Monitor System (1, 2)
5	Shield disconnect jumper (X100, X101)
6	Module power fuses (MODULE 1, MODULE 2)
7	Module power fuse indicators
8	Input isolation Jumper (X300)
9	HART connectivity terminals (CHx HRT+)
10	HART connectivity ground (COM HRT-)
11	Channel Input Disconnect Jumper (CON/DIS)
12	Zener diodes
13	Shield Ground Stud for connecting to earth ground

11.7 Technical Specifications

Technical Specifications for 6-Channel F Analog Input HART MTA 6ES7650-1AH62-5XX0 in use with FAIH-module 6ES7336-4GE00-0AB0 and cables 6ES7392-3Bx00-0AU0		
Dimensions - See Section 1, Figure 1.3, Short Version		
Mounting		
DIN Rail	35mm (deep top hat style)	
Power Input		
Voltage Input for Single or Redundant Feed	21.6 to 28.8 VDC	
Current Consumption (nominal ratings; all channels 20 mA)	< 0.5 A	
Power Dissipation (typical)	1 W	
Fuse Ratings		
Module Power	0.5 A (Bussmann P/N: GMA-0.5A) (Siemens Spare P/N: A5E01568885)	
Power output for 2-wire transducer supply		
Supply current for each channel	typ. 20 mA	
Short circuit current	max. 40 mA	
Load capability	> 750 Ω	
Open loop voltage	max. L+	
Short circuit protection	electronically; individual for each channel	
Power Monitoring System - Optorelay Output Contact Ratings		
Threshold voltage	ca. 15 V	
Maximum switched Voltage	30 V DC	
Maximum switched Current	0.5 A resistive load; not short circuit proofed	
Indicators		
Input Power	Green LED on when input power available red LED on if power supply is reversed	
Field Terminals		
Wire Size – US	24 – 14 AWG	
Wire Size – Metric	0,205 – 2,08 mm sq.	
Environmental		
Ambient Temperature	-25°C to +70°C (Horizontal Mounting) -25°C to +60°C (Vertical Mounting)	
Humidity	5% to 95% Non-condensing	
Approvals		
Maximum achievable safety class in safety mode (depends on the voting of the corresponding I/O module)	1oo1 voting	1oo2 voting
SIL according to IEC 61508, DIN EN 62061	SIL 3	SIL 3
Performance Level according to EN ISO 13849-1	PLe	PLe
Category according to EN ISO 13849-1	Cat. 3	Cat. 4

Technical Specifications for 6-Channel F Analog Input HART MTA 6ES7650-1AH62-5XX0 in use with FAIH-module 6ES7336-4GE00-0AB0 and cables 6ES7392-3Bx00-0AU0	
Low Demand (PFD) according to SIL 3 (per channel)	< 1,45 E-4
High Demand (PFH) according to SIL 3 (per channel)	< 1,9 E-9 1/h
Proof-test interval	20 years

Note

Fuses are available as spare parts from Siemens.

Fuse information can be found at:

<http://www.littelfuse.com>

<http://www.bussmann.com>

11.8 Changes to the Technical Specifications for 6-Channel F ANALOG INPUT HART Module (6ES7 336-4GE00-0AB0)

This section contains changes to the I/O module specifications when it is used with the MTA.

Changes for 6-Channel F Analog Input HART MTA (6ES7650-1AH61-5XX0)	
Transmitter Connections	Only 1 transmitter can be connected to a channel.
Output voltage for 2 wire transducer and cable with 22 mA transducer current @ 24 V Supply*	non redundant mode: 17 V redundant mode: 14 V
Fail-safe Performance Characteristics	Adds a dangerous undetected failure rate 6.3 FIT for 6 channels) to the FAI module in any configuration.
Sensor Supply	The FAI module internal sensor supply outputs are not used when using the FAIH MTA.
Protection against short circuit with MTA sensor supply	No external fuse required. The FAIH MTA limits current.
* If the output voltage is not sufficient for a 2 wire transmitter, safety barrier and field wiring, it is recommended that a 4 wire transmitter be used.	

11.9 Typical Transmitter Connection to Field Terminals

Figure 11-5 Transmitter Connection to Field Terminals

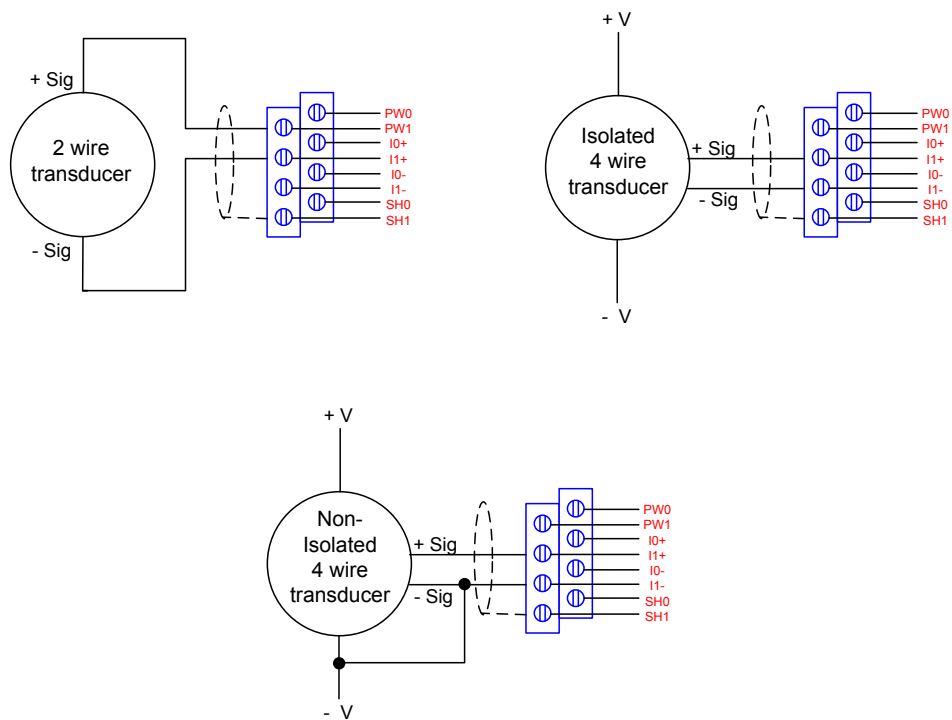

Hardware Configuration

For hardware configuration refer to the manual *S7-300 Automation System Fail-Safe Signal Modules* (document number A5E00085586).

11.10 Technical Specifications for 6-Channel F ANALOG INPUT HART Module (6ES7 336-4GE00-0AB0)

Note

For a complete functional description and the most current technical specifications for this module, refer to the manual *S7-300 Automation System Fail-Safe Signal Modules* (document number A5E00085586).

11.11 Input Sharing

11.11.1 Description

This section contains information and requirements for input sharing between a Failsafe Analog Input module (6ES7 336-4GE00-0AB0) and a Standard Analog Input Module (6ES7 331-7NF00-0AB0, E-Stand 5 and higher or 6ES7 331-7NF10-0AB0, E-Stand 8 or higher), using the Siemens FAIH Marshallled Termination Assembly (MTA) (6ES7650-1AH62-5XX0 and the Siemens AI Marshallled Termination Assembly (MTA) (6ES7650-1AA52-2XX0).

11.11.2 Purpose

Input sharing allows the transmitter signal to be distributed to both the Fail-Safe Analog Input Module and the Standard Analog Input Module. Both systems will then receive the same input data.

Figure 11–6 FAIH SAI Input Sharing

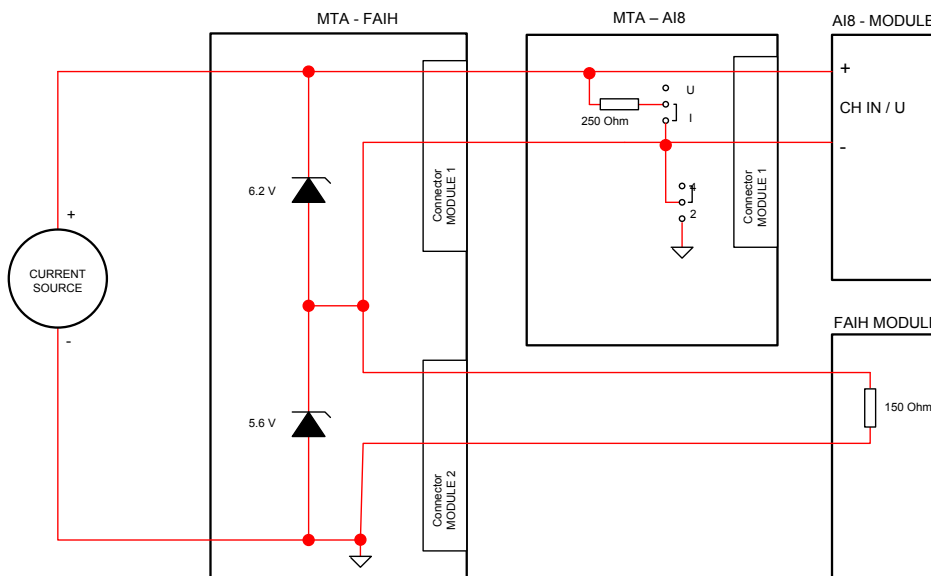

11.11.3 Operation

The signal source is connected to the FAIH MTA in the normal manner. The cable plugged into the connector MODULE 1 is wired from IxR+ to Ix+ and Ix- to Ix- on field connections of the Standard Analog Input MTA-AI8 (6ES7650-1AA52-2XX0). The MTA-AI8 jumpers **V/I** are set for current mode (I) and the jumpers **2/4** are set for 4 wire mode (4) for each channel connected to the FAIH MTA. The AI8 Module is connected to the MTA-AI8 using the standard cables. See Table 1-2.

11.11.4 FAIH MTA to SAI MTA Cable

The FAIH MTA to SAI MTA Input Sharing cable uses only 13 conductors. The FAIH Channel 0 to Channel 5 input signals have been mapped to Channels 0 through 5 on the SAI MTA. Channels 6 and 7 of the SAI can be used for other inputs. The cable connections can be seen in the table below.

The FAIH MTA to SAI MTA Input Sharing cable is custom manufactured on a project basis. See the project manager to for more information.

The assembly view of the cable can be seen in Figure 10–10.

Table 11–1 FAIH MTA to SAI MTA Cable

FAIH Channel	FAIH MTA Signal	FAIH MTA D50M Pin	SAI MTA Field Terminal	SAI MTA Signal	SAI Channel
CH 0+	I0R+	19	TB1 PIN 2	I0+	CH 0+
CH 0-	I0-	27	TB1 PIN 3	I0-	CH 0-
CH 1+	I1R+	20	TB1 PIN 6	I1+	CH 1+
CH 1-	I1-	28	TB1 PIN 7	I1-	CH 1-
CH 2+	I2R+	38	TB1 PIN 10	I2+	CH 2+
CH 2-	I2-	46	TB1 PIN 11	I2-	CH 2-
CH 3+	I3R+	23	TB1 PIN 14	I3+	CH 3+
CH 3-	I3-	47	TB1 PIN 15	I3	CH 3-
CH 4+	I4R+	40	TB2 PIN 2	I4+	CH 4+
CH 4-	I4-	15	TB2 PIN 3	I4-	CH 4-
CH 5+	I5R+	8	TB2 PIN 6	I5+	CH 5+
CH 5-	I5-	16,17, 32	TB2 PIN 7	I5-	CH 5-
	Shield	Shield	TB1 PIN 4 ⁷	SH0	

⁷ The shield connection to the SAI MTA is optional and should be investigated for safe operation before use

Figure 11-7 FAIH MTA to SAI MTA Interconnecting Cable

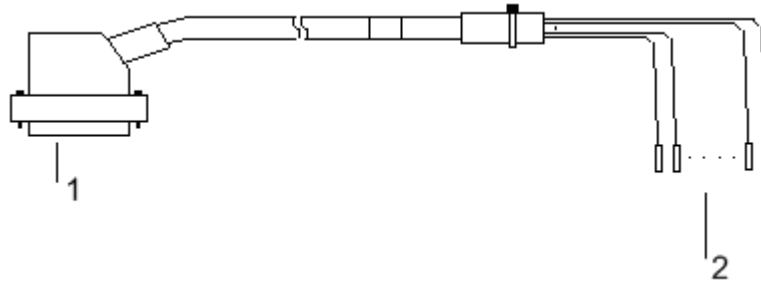

Key to numbered items in Figure 10-10:

Item	Part Name
1	50-PIN FEMALE sub-D connector
2	Wires with crimped pins

11.11.5 Hardware Configuration

FAI: Redundancy not supported. The HW configuration should be setup for Non-redundant operation.

SAI: The SAI MTA supports redundancy for the Standard Modules and redundant modules can be used, as selected by the user. See section 4.10.

Addresses

FAI: Input address and process image should be set to the user preferences.

SAI: Input address and process image should be set to the user preferences. See section 4.10.

Inputs

FAI: Set to user preferences.

SAI: Under the **Inputs** tab the **Measuring Type** should be set to **4DMU** (current) with **Measuring Range** set to **4..20 mA**. All other settings are up to the user. See section 4.10.

Because the FAI has only 6 inputs the SAI will only use 6 inputs for the sharing operation. The other two inputs can be used for other analog signals.

Figure 11–8 SAI 8-Channel Analog Input Hardware Configuration: Inputs Sharing Configuration

Properties - AI8x16Bit - (R-/54)

General | Addresses | Inputs | Redundancy

Enable

Diagnostic Interrupt Hardware Interrupt When Limit Exceeded

Input	0 - 1	2 - 3	4 - 5	6 - 7
Diagnostics				
Group Diagnostics:	<input checked="" type="checkbox"/>	<input checked="" type="checkbox"/>	<input checked="" type="checkbox"/>	<input type="checkbox"/>
with Check for Wire Break:	<input checked="" type="checkbox"/>	<input checked="" type="checkbox"/>	<input checked="" type="checkbox"/>	<input type="checkbox"/>
Measuring				
Measuring Type:	4DMU	4DMU	4DMU	...
Measuring Range:	4..20 mA	4..20 mA	4..20 mA	...
interference frequency	60 Hz	60 Hz	60 Hz	...
Trigger for Hardware Interrupt	Channel 0	Channel 2		
High Limit:	<input type="text"/> mA	<input type="text"/> mA		
Low Limit:	<input type="text"/> mA	<input type="text"/> mA		

OK Cancel Help

Redundancy

FAI: Redundancy not supported. The HW configuration should be setup for non-redundant operation.

SAI: The SAI MTA supports redundant and non-redundant operation. See section 4.10.

Figure 11–9 SAI 8-Channel Analog Input Hardware Configuration for Non-redundant Operation

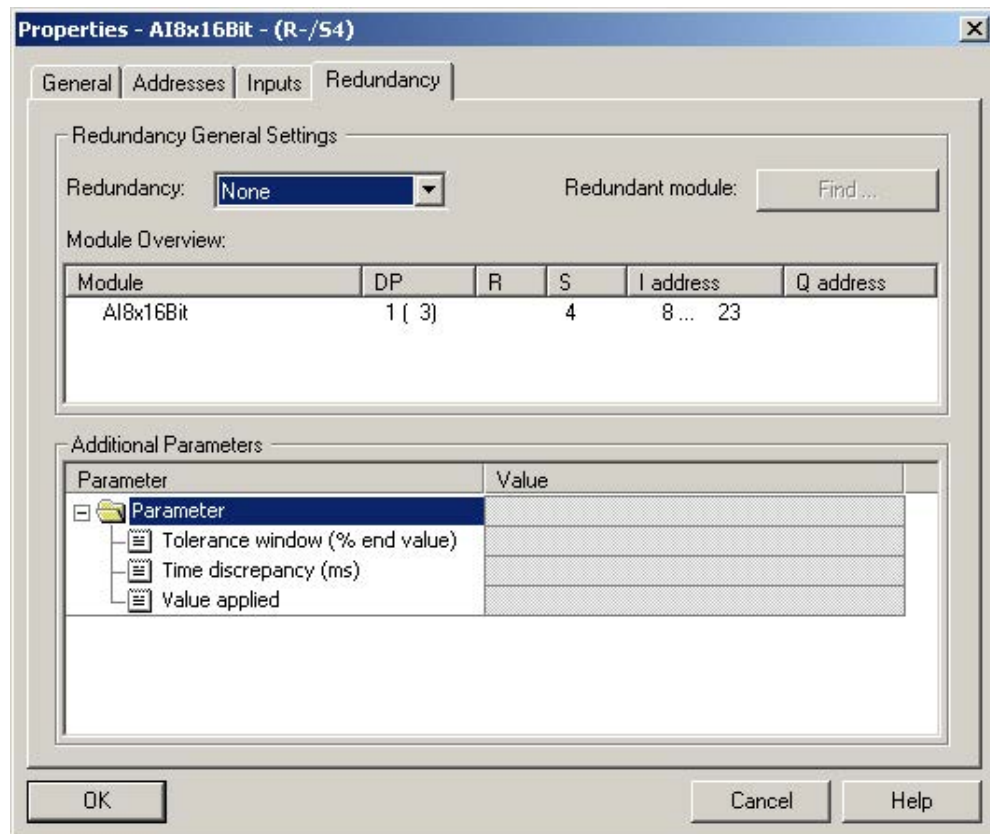

12 16-Channel, 24 VDC Discrete Input MTA

Part No. 6ES7650-1AC11-3XX0 or 6ES7650-1AC10-3XX0

12.1 Description

This section contains information and requirements for Siemens Marshalled Termination Assembly (MTA) (6ES7650-1AC11-3XX0 or 6ES7650-1AC10-3XX0), designed to interface with the Siemens ET 200M 16-Channel, 24 VDC Discrete Input Module (6ES7 321-7BH01-0AB0, E-Stand 2 or higher)

Note: The only major difference between the two part numbers is the housing. The Anthracite Gray housing is the latest design. Functionality of both part numbers is the same.

12.2 Features

The following features have been incorporated into this MTA:

- Redundant power connections
- LED indication of redundant power supply condition
- Power monitor plug-in available (optional)
- LED indication of power supply to the field device on an individual channel basis
- Per channel fusing of field power
- Dual connectors for redundant I/O Module operation
- Per module power fusing
- Shield connections available for channel cabling
- Ground stud for connecting shield to earth ground
- Power input and field terminations are pluggable for easy maintenance

12.3 Operation

Power is supplied via the two removable power connectors which are retained by screws and marked **L+A, MA**, and **L+B, MB**. Each has a LED to indicate the presence of voltage over 15 VDC. The LEDs are marked **A POWER** and **B POWER**. There is also a connector (**J3**) for a Power Monitor board used to indicate the presence of both A and B power. See Section 19, *Power Monitor Board* (6ES7650-1BA02-0XX0).

Incoming power from **A** and **B** is diode OR'd, in **CR106**, to provide the MTA and the module power from either input source. The output from **CR106** is sent to the I/O modules via the module fuses and to the channels via the channel fuses. Module Fuse 1 (**F100**) supplies the I/O Module plugged into **J1** and Module Fuse 2 (**F101**) supplies power to the I/O Module plugged into **J2**.

Each channel has an LED to indicate the presence of power and the fuse status. If there is no power or the fuse is open, then the LED remains off. If there is power and the fuse is good, then the LED is illuminated.

Field Terminals, Channel + (**CHx+**), Channel – (**CHx-**), and Shield (**SHx**), connect to the field devices. **CHx+** is the +24 VDC power feed and is fused (.05A) on a channel-by-channel basis. The field termination connector is removable for ease of wiring maintenance and is retained by friction.

The **CHx-** connects to the I/O modules input via **J1** and **J2**. Redundant operation uses two modules, one connected to **J1** and the other to **J2**. In non-redundant systems, the module connects to either **J1** or **J2**.

12.4 Installation Requirements

See Section 2, *Installation*, before performing any installation and observe all warnings

Common interconnecting cables (6ES7922-3BD00-0AM0, 6ES7922-3BJ00-0AM0, 6ES7922-3BD01-0AM0 or 6ES7922-3BJ01-0AM0), supporting 16 DI channels, interconnect the discrete input termination assembly to the 16-channel, 24 VDC discrete input module (6ES7 321-7BH01-0AA0, E-Stand 2 or higher).

Note

To disconnect the interconnecting cable shield from ground at the MTA only, cut and remove the shield disconnect jumper, W100 and W101, for the associated cable

12.5 Maintenance

See Section 3, *Maintenance*, before performing any maintenance and observe all warnings

Under normal operation, the **A/B Power LED**, the **Module 1/2 Fuse LED**, and all the **Channel Fuse LEDs** are on. If all are off, check the power supply to MTA. If the **A/B Power LED** is off, check the power supply to the MTA. If the **Module 1/2 Fuse LED** is off, check and replace the module fuse. If the **Channel Fuse LED** is off, check and replace the channel fuse.

12.6 16-Channel, 24 VDC Discrete Input Marshallled Termination Assembly

Figure 12–1 shows the basic parts of the 16-Channel, 24 VDC Discrete Input MTA.

Figure 12–1 16-Channel, 24 VDC Discrete Input Marshallled Termination Assembly

(6ES7650-1AC11-3XX0 or 6ES7650-1AC10-3XX0)

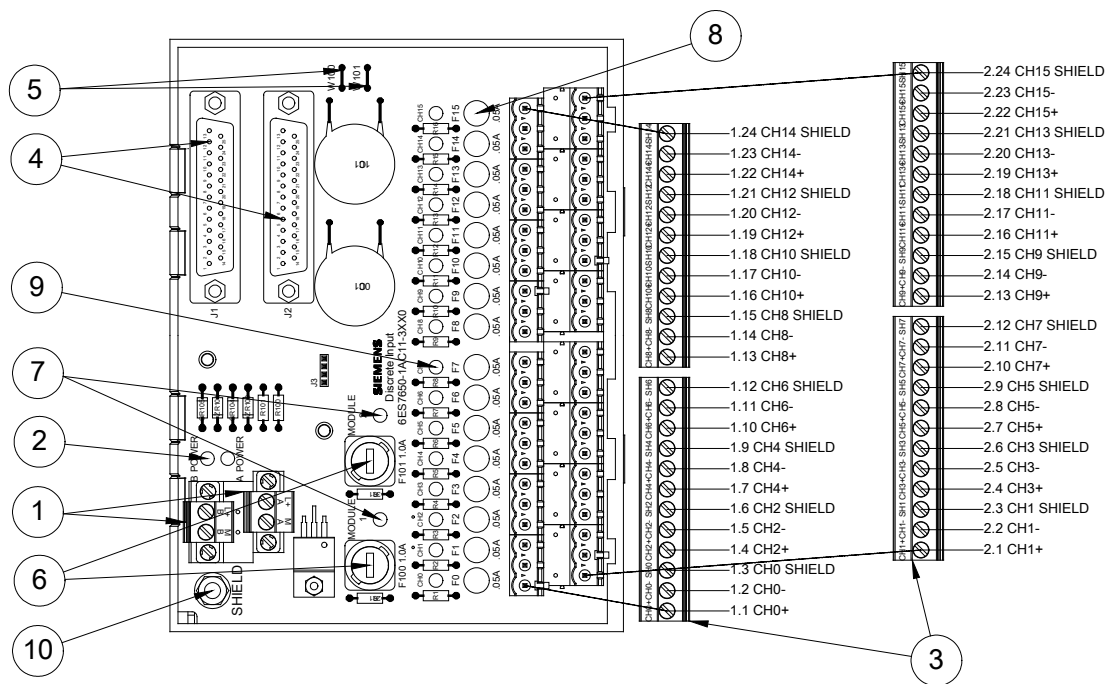

Key to numbered items in Figure 12–1:	
Item	Description
1	Input power connections
2	Input power indicators
3	Field wiring connections
4	I/O module connections
5	Shield disconnect jumpers (W100 & W101)
6	Module power fuses
7	Module power indicators
8	Channel Power Fuse (1 of 16)
9	Channel power indicator (1 of 16)
10	Shield Ground Stud for connecting to earth ground

12.7 Technical Specifications

Technical Specifications for 16-Channel, 24 VDC Discrete Input MTA (6ES7650-1AC11-3XX0 or 6ES7650-1AC10-3XX0)	
Dimensions - See Section 1, Figure 1.3, Short Version	
Mounting	
DIN Rail	35mm (deep top hat style)
Power Input	
Voltage Input for Single or Redundant Feed	21.6 to 28.8 VDC
Current Consumption (nominal ratings; all channels connected)	
All Channels at +24 VDC	0.578 A maximum
All Channels at 0 VDC	0.258 A maximum
Power Dissipation (typical)	1 W
Terminal Block Wire Sizes	TB100 & TB101
Wire Size – US	24 – 14 gauge AWG
Wire Size – Metric	0,205 – 2,08 mm sq.
Power Supply Specifications	See Module Specs
Fuse Ratings	
Individual channel	0.05 A (Littelfuse P/N: 273.050) (Siemens Spare P/N: A5E01568887)
Module Power	1.0 A (Bussmann P/N: GMA-1.0A) (Siemens Spare P/N: A5E01568882)
Indicators	
Input Power	Green LED on when input power available
Module Power	Green LED on when module power available
Channel Power	Green LED on when sensor power available
Field Terminal Block Wire Sizes TB1 – TB4	
Wire Size – US	24 – 14 gauge AWG
Wire Size – Metric	0,205 – 2,08 mm sq.
Environmental	
Ambient Temperature	-25C to +60C
Humidity	5% to 95% Non-condensing
Approvals	
MTA Agency Approvals	See Preface section, Approvals Table

Note

Fuses are available as spare parts from Siemens.

Fuse information can be found at:

<http://www.littelfuse.com>

<http://www.bussmann.com>

12.8 Module Restrictions

Restrictions for 16-Channel, 24 VDC Discrete Input MTA (6ES7650-1AC11-3XX0 or 6ES7650-1AC10-3XX0)	
I/O Module Restrictions	
MTA Design: Module Vs not used	Cross circuit between channels of a channel group - not detected
MTA Design: Module Vs not used	Cross circuit between channels in different channel groups - not detected
MTA Design: Module Vs not used	The “No Sensor Supply” boxes should not be selected under: 16-Channel Discrete Input Hardware Configuration – Inputs (see Section 9.10.2)

12.9 Typical Transmitter Connection to Field Terminals

Figure 12–2 16 Channel DI MTA Field Terminal Connection to Transmitter

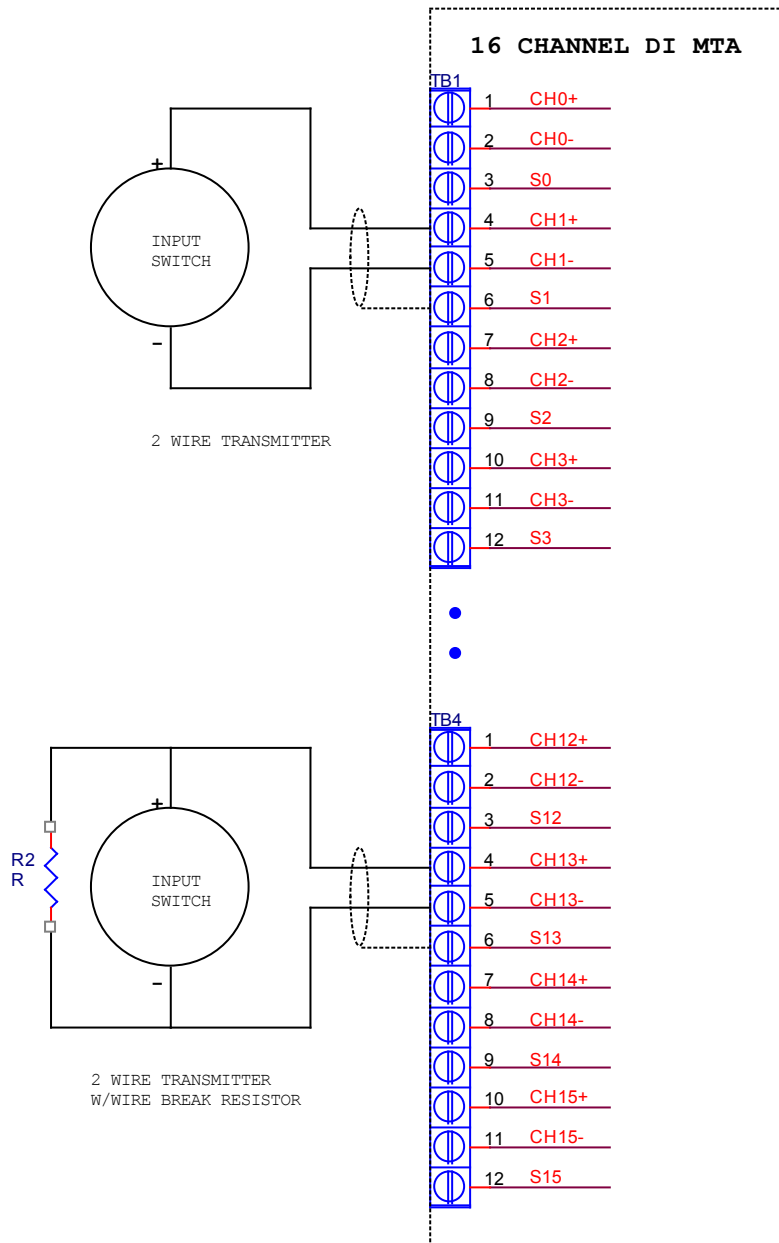

Note

The Wire Break resistor value for redundant DI modules should be between 10 KΩ and 12 KΩ.

The Wire Break resistor value for a non-redundant DI module can be found in the *S7-300 Programmable Controller Module Specifications* (document number A5E00105505).

12.10 Hardware Configuration

The 16 channel Standard Discrete Input Module and its MTA support Redundant and Non-redundant operation.

12.10.1 Addresses

Non-redundant Operation

The choice of the Input Address and Process Image are left to the user.

Redundant Operation

Process Image should be set to something other than the default. The choice of the Input Address is left to the user.

Figure 12–3 shows a redundant configuration.

Figure 12–3 16-Channel Discrete Input Hardware Configuration: Address for Redundant Configuration

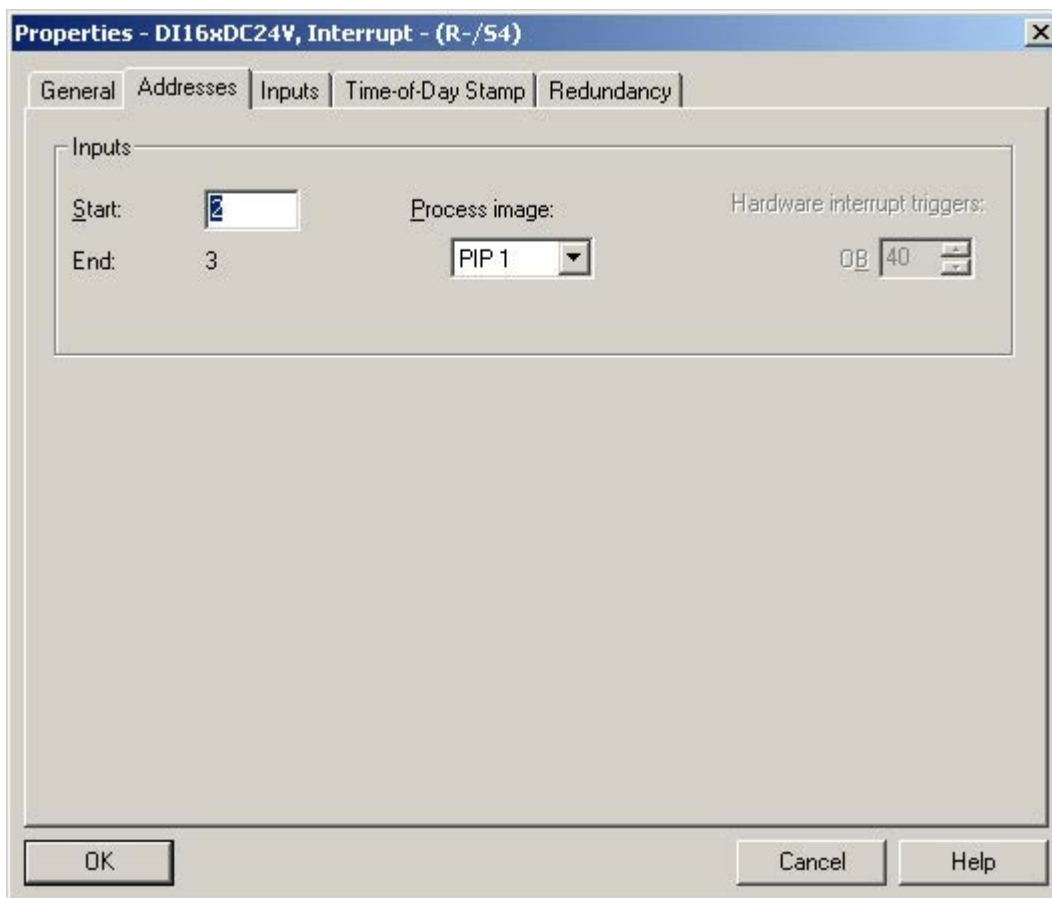

12.10.2 Inputs

The inputs of the SDI module are capable of wire break detection if a resistor is wired in parallel with the sensor, the resistor should be located near the sensor. See Figure 12–4. The **Wire Break** option must be checked for each channel that will use this feature.

Also, the **No sensor supply** boxes should not be checked because the sensor does not use the VS from the module as a supply. Not using VS eliminates some of the diagnostics from operating. See the “IO Module Restrictions” in the Technical Specifications table.

All other options should be set for the user preferences.

Figure 12–4 shows the SDI with all 16 channels using the wire break option and the **No sensor supply** option not selected.

Figure 12–4 16-Channel Discrete Input Hardware Configuration: Inputs

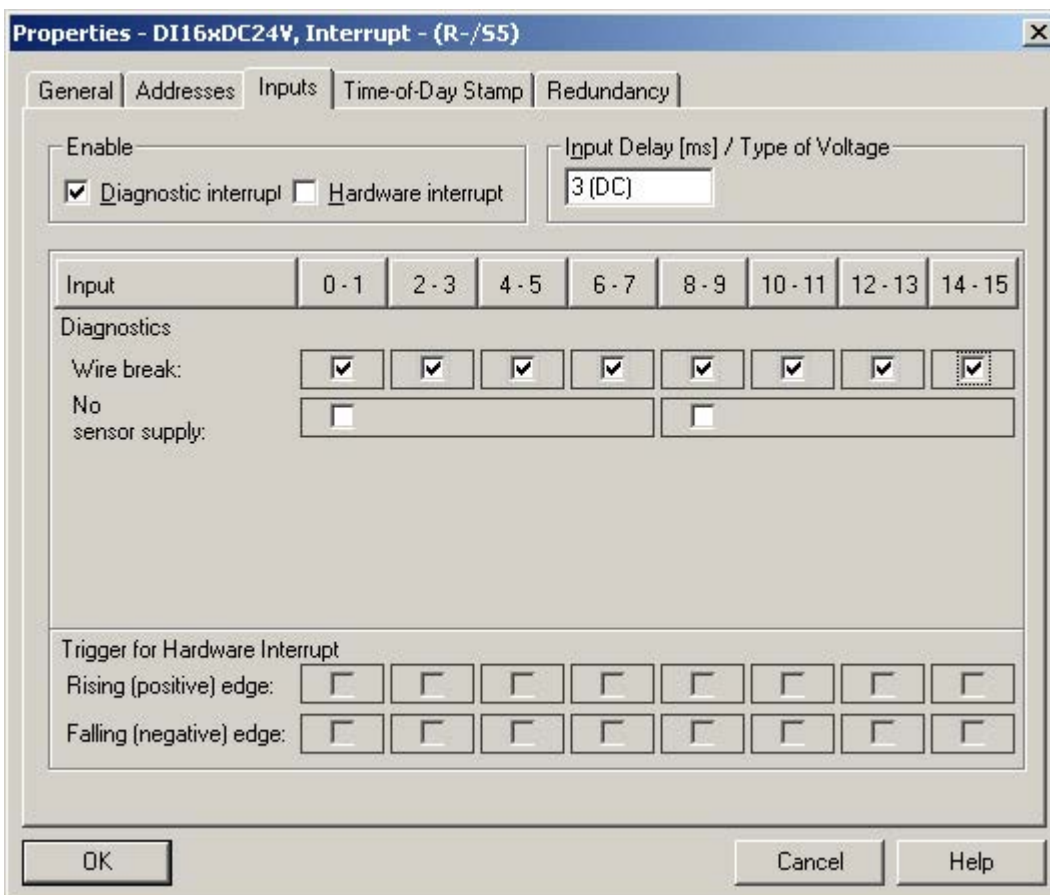

12.10.3 Time-of-Day Stamp

All of these options should be set to user preferences.

Figure 12–5 16-Channel Discrete Input Hardware Configuration: Time-of-Day Stamp Options

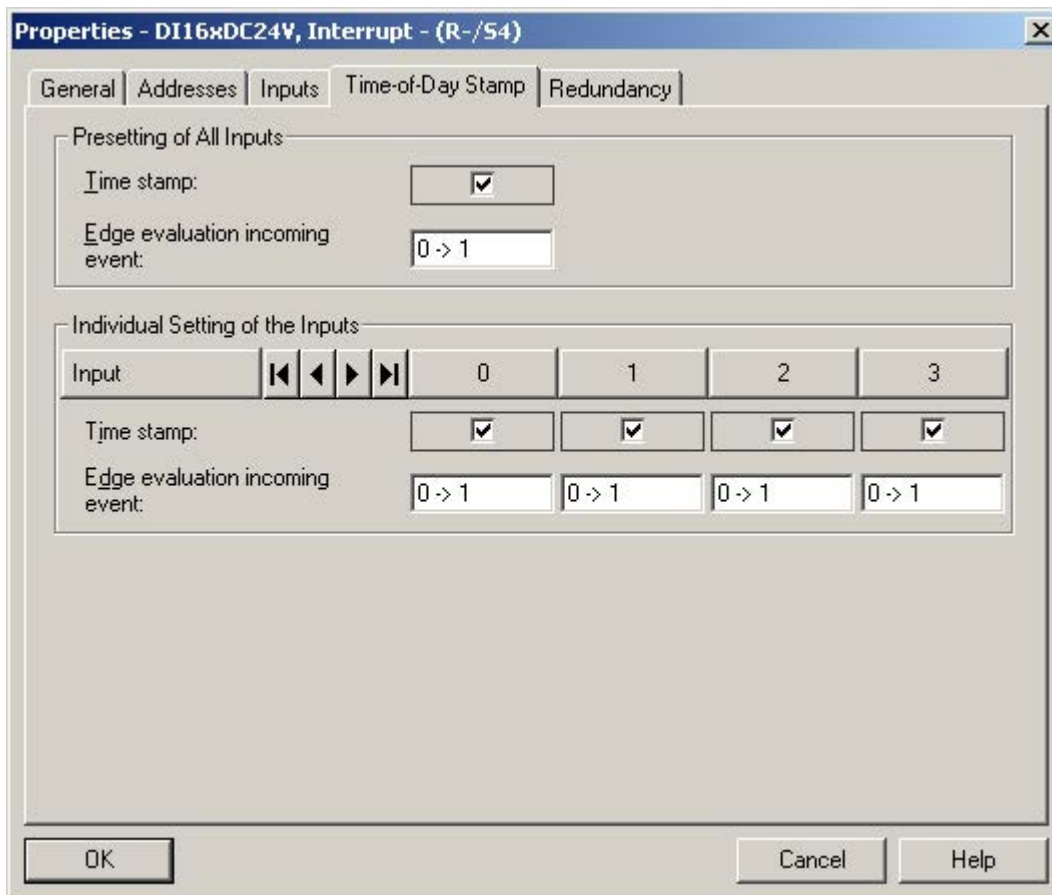

12.10.4 Redundancy

Figure 12–6 shows a redundant SDI configuration.

Figure 12–6 16-Channel Discrete Input Hardware Configuration: Redundancy Selection

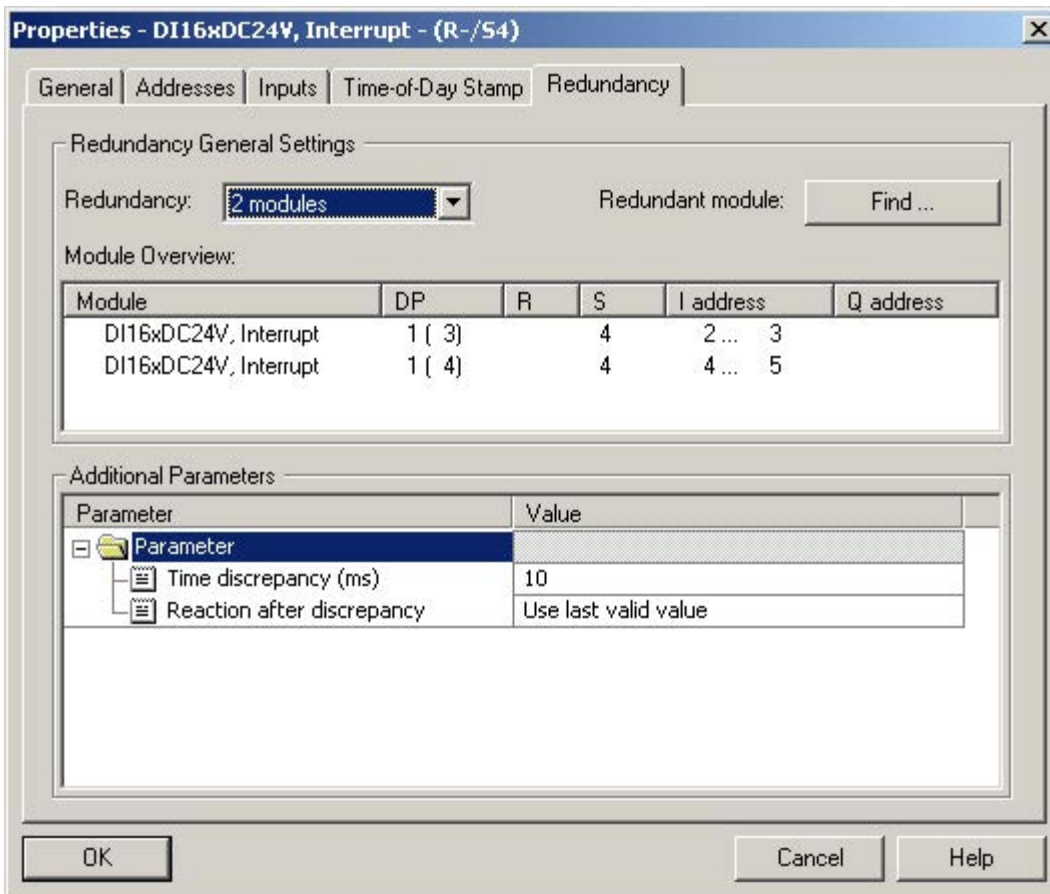

12.11 Technical Specifications for 16-Channel, 24 VDC Discrete Input Module (6ES7 321-7BH01-0AB0)

Note

For a complete functional description and the most current technical specifications for this module, refer to the manual *S7-300 Programmable Controller Module Specifications* (document number A5E00105505).

13 12/24-Channel, 24 VDC F Discrete Input MTA

Part No. 6ES7650-1AK11-7XX0 or 6ES7650-1AK10-7XX0

13.1 Description

This section contains information and requirements to facilitate installation of Siemens Marshalled Termination Assembly (MTA) (6ES7650-1AK11-7XX0 or 6ES7650-1AK10-7XX0), designed to interface with the Siemens ET 200M 12/24-Channel, 24 VDC F Discrete Input module (6ES7 326-1BK02-0AB0, E-Stand 1 or higher).

Note: The only major difference between the two part numbers is the housing. The Anthracite Gray housing is the latest design. Functionality of both part numbers is the same.

13.2 Features

The following features have been incorporated into this MTA:

- Redundant power connections
- LED indication of redundant power supply condition
- Power monitor plug-in available (optional)
- Dual connectors for redundant I/O Module operation
- Per module power fusing
- LED indication of power supply to the field device on an individual channel basis
- Per channel fusing of field power
- Per channel disconnects
- Shield connections available for channel cabling
- Ground stud for connecting shield to earth ground
- Power input and field terminations are pluggable for easy maintenance

13.3 Operation

Power is supplied via the two removable power connectors which are retained by screws and marked **L+A, MA**, and **L+B, MB**. Each has a LED to indicate the presence of voltage over 15 VDC. The LEDs are marked **A POWER** and **B POWER**. There is also a connector (**J3**) for a Power Monitor board used to indicate the presence of both A and B power. See Section 19, *Power Monitor Board* (6ES7650-1BA02-0XX0).

Incoming power from **A** and **B** is diode OR'd, in **CR106**, to provide the MTA and the module power from either input source. The output from **CR106** is sent to the I/O modules via the module fuses and to the channels via the channel fuses. Module Fuse 1 (**F100**) supplies the I/O Module plugged into **J1** and Module Fuse 2 (**F101**) supplies power to the I/O Module plugged into **J2**.

Each channel has an LED to indicate the presence of power, fuse, and disconnect switch status. If there is no power, or the fuse or disconnect switch is open, then the LED remains off. If there is power and the fuse is good and the disconnect switch is closed, then the LEDs are illuminated.

Field Terminals, Channel + (**CHx+**), Channel – (**CHx-**), and Shield (**SHx**), connect to the field devices. **CHx+** is the +24 VDC power feed and is fused (.05A) on a channel-by-channel basis. The field termination connector is removable for ease of wiring maintenance and is retained by friction.

The **CHx-** connects to the I/O modules input via **J1** and **J2**. Redundant operation uses two modules with one each connected to **J1** and **J2**, while non-redundant systems have one module connected to either **J1** or **J2**.

13.4 Installation Requirements

See Section 2, *Installation*, before performing any installation and observe all warnings

Common interconnecting cables (6ES7922-3BD00-0AS0 and 6ES7922-3BJ00-0AS0 and 6ES7 326-1BK02-0AB0), supporting the Failsafe Discrete Input channels, interconnect the discrete input termination assembly to the 12/24-channel, 24 VDC Failsafe Discrete Input module (6ES7 326-1BK00-0AB0, or 6ES7 326-1BK01-0AB0, E-Stand 1 or higher).

Note

To disconnect the interconnecting cable shield from ground at the MTA only, cut and remove the shield disconnect jumper, **W100** and **W101**, for the associated cable

13.5 Maintenance

See Section 3, *Maintenance*, before performing any maintenance and observe all warnings

Under normal operation, the **A/B Power LED** and the **Module 1/2 Fuse LED** are on. If all are off, check the power supply to MTA. If the **A/B Power LED** is off,

check the power supply to the MTA. If the **Module 1/2 Fuse LED** is off, check the channel fuse and replace as necessary.

13.6 Simplified diagram

Figure 13–1 12/24-Channel, 24 VDC F Discrete Input Marshallled Termination Assembly (6ES7650-1AK11-7XX0 or 6ES7650-1AK10-7XX0)

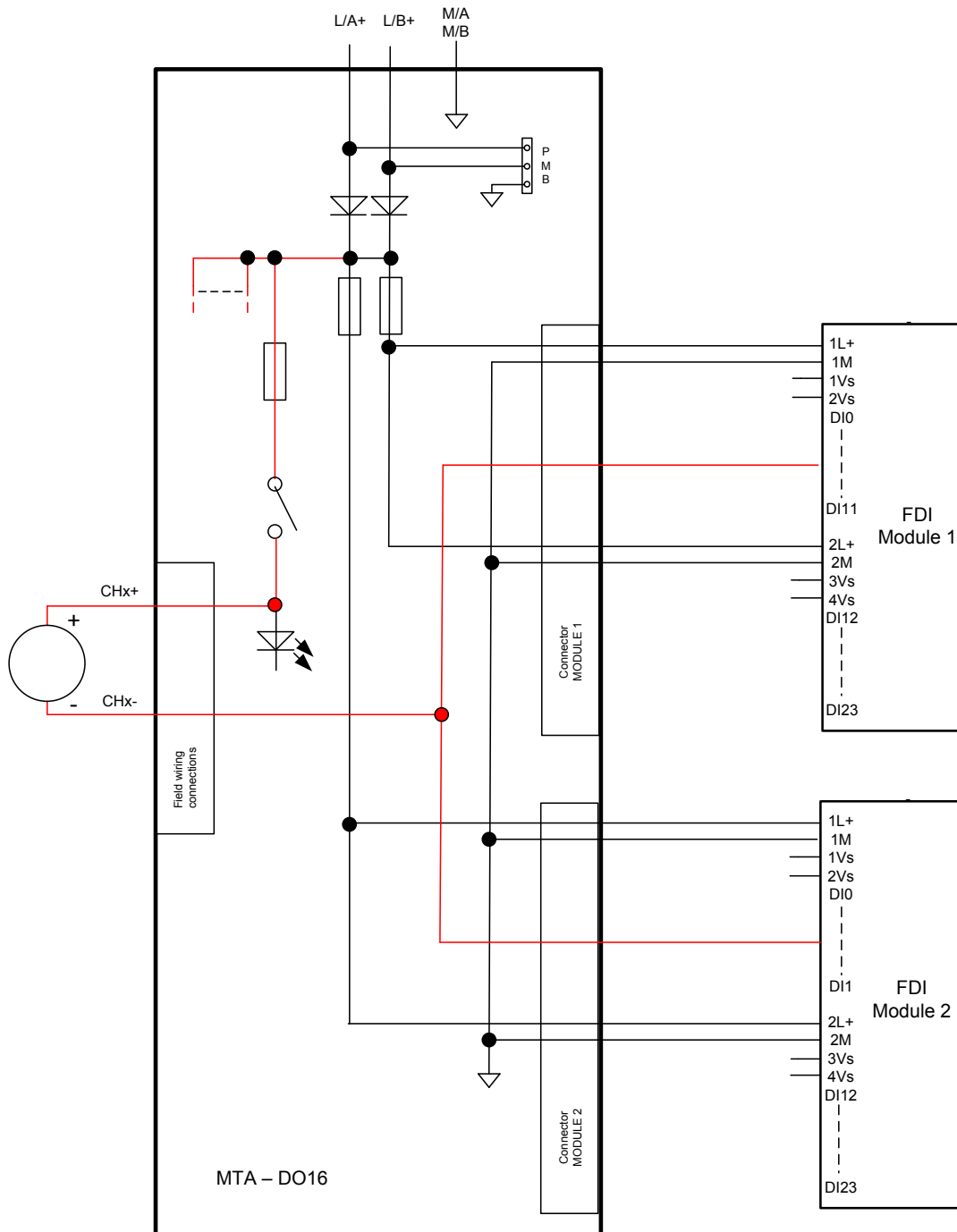

13.7 12/24-Channel, 24 VDC F Discrete Input Marshallled Termination Assembly

The figure below shows the basic parts of the 12/24-Channel, 24 VDC F Discrete Input MTA.

Figure 13-2 12/24-Channel, 24 VDC F Discrete Input Marshallled Termination Assembly (6ES7650-1AK11-7XX0 or 6ES7650-1AK10-7XX0)

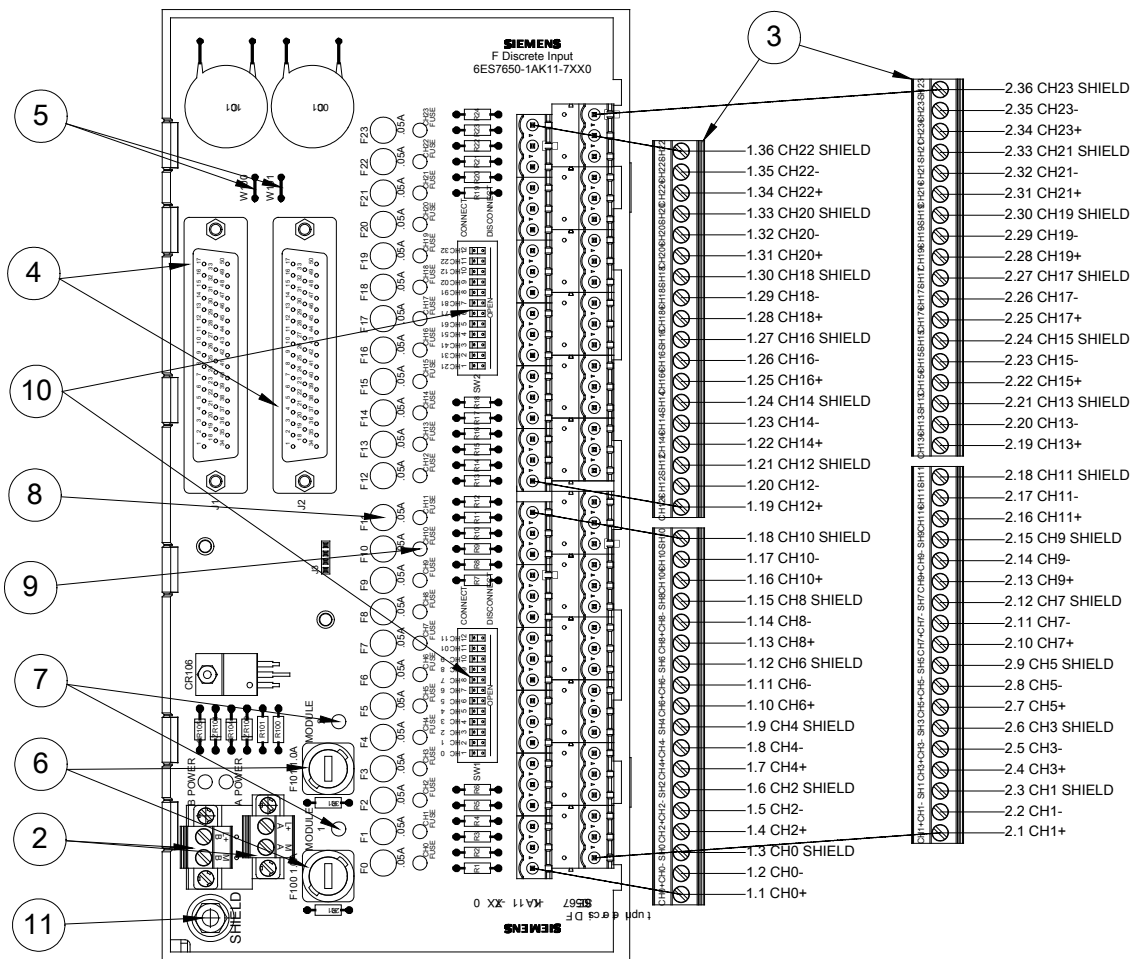

Key to numbered items in Figure 13-:	
Item	Description
1	Input power connections
2	Input power indicators
3	Field wiring connections
4	I/O module connections
5	Shield disconnect jumpers (W100 & W101)
6	Module power fuses
7	Module power indicators
8	Channel power fuse (1 of 24)
9	Channel power indicator (1 of 24)
10	Channel power disconnect switches (SW1 & SW2)
11	Shield Ground Stud for connecting to earth ground

Switch **Off** the channel power disconnect switches to disconnect field power for the channel.

13.8 Technical Specifications

Technical Specifications: 12/24-Channel, 24 VDC F Discrete Input MTA (6ES7650-1AK10-7XX0)	
Dimensions - See Section 1, Figure 1.3, Long Version	
Mounting	
DIN Rail	35mm (deep top hat style)
Power Input	
Voltage Input for Single or Redundant Feed	21.6 to 28.8 VDC
Current Consumption (nominal ratings)	
All inputs at +24 VDC	1.482 A maximum
All inputs at 0 VDC	1.002 A maximum
Power Dissipation (typical)	3 W
Terminal Block Wire Sizes	TB100 & TB101
Wire Size – US	24 – 14 gauge AWG
Wire Size – Metric	0,205 – 2,08 mm sq.
Power Supply Specifications	See Module Specs
Fuse Ratings	
Individual channel	0.05 A (Littelfuse P/N: 273.050) (Siemens Spare P/N: A5E01568887)
Module Power	1.0 A (Bussmann P/N: GMA-1.0A) (Siemens Spare P/N: A5E01568882)
Indicators	
Input Power	Green LED on when input power available
Module Power	Green LED on when Module power available
Channel Power	Green LED on when sensor power available

Field Terminal Block Wire Sizes TB1 – TB4	
Wire Size – US	24 – 14 gauge AWG
Wire Size – Metric	0,205 – 2,08 mm sq.
Environmental	
Ambient Temperature	-25C to +60C
Humidity	5% to 95% Non-condensing
Approvals	
MTA Agency Approvals	See Preface section, Approvals Table
Max achievable Safety Integrity Level in safety mode	
In Accordance with IEC 61508	SIL 3
Fail-safe performance characteristics (no dangerous undetected failures for DI MTA)	
Low demand mode (average probability of failure on demand) per channel	PFDavg = 0
High Demand / continuous mode (probability of dangerous failure per hour per channel)	PFH = 0
Proof-test time	20 years

13.9 Technical Specifications

Technical Specifications: 12/24-Channel, 24 VDC F Discrete Input MTA (6ES7650-1AK11-7XX0)	
Dimensions - See Section 1, Figure 1.3, Long Version	
Mounting	
DIN Rail	35mm (deep top hat style)
Power Input	
Voltage Input for Single or Redundant Feed	21.6 to 28.8 VDC
Current Consumption (nominal ratings)	
All inputs at +24 VDC	1.482 A maximum
All inputs at 0 VDC	1.002 A maximum
Power Dissipation (typical)	3 W
Terminal Block Wire Sizes	TB100 & TB101
Wire Size – US	24 – 14 gauge AWG
Wire Size – Metric	0,205 – 2,08 mm sq.
Power Supply Specifications	See Module Specs
Fuse Ratings	
Individual channel	0.05 A (Littelfuse P/N: 273.050) (Siemens Spare P/N: A5E01568887)
Module Power	2.0 A (Bussmann P/N: GMA-1.0A) (Siemens Spare P/N: A5E01568882)
Indicators	

Technical Specifications: 12/24-Channel, 24 VDC F Discrete Input MTA (6ES7650-1AK11-7XX0)		
Input Power	Green LED on when input power available	
Module Power	Green LED on when Module power available	
Channel Power	Green LED on when sensor power available	
Field Terminal Block Wire Sizes TB1 – TB4		
Wire Size – US	24 – 14 gauge AWG	
Wire Size – Metric	0,205 – 2,08 mm sq.	
Environmental		
Ambient Temperature	-25C to +70C (Horizontal mounting) -25C to +60C (Vertical mounting)	
Humidity	5% to 95% Non-condensing	
Approvals		
Maximum achievable safety class in safety mode (depends on the voting of the corresponding I/O module)	1oo1 voting	1oo2 voting
SIL according to IEC 61508, DIN EN 62061	SIL 2	SIL 3
Performance Level according to EN ISO 13849-1	PLd	PLe
Category according to EN ISO 13849-1	Cat. 3	Cat. 4
Low Demand (PFD) according to SIL 3 (per channel)	0 (no dangerous undetected failures for DI MTA)	
High Demand (PFH) according to SIL 3 (per channel)	0 1/h (no dangerous undetected failures for DI MTA)	
Proof-test time	20 years	

Note

Fuses are available as spare parts from Siemens.

Fuse information can be found at:

<http://www.littelfuse.com>

<http://www.bussmann.com>

13.10 Module Restrictions

Restrictions for 12/24-Channel, 24 VDC F Discrete Input MTA (6ES7650-1AK11-7XX0 or 6ES7650-1AK10-7XX0)	
I/O Module Restrictions	
MTA Design:	Connection of 2 redundant sensors to one channel is not possible
MTA Design: Module Vs not used	Short Circuit to L+ on the unswitched sensor line (contact open) - not detected

Restrictions for 12/24-Channel, 24 VDC F Discrete Input MTA (6ES7650-1AK11-7XX0 or 6ES7650-1AK10-7XX0)	
MTA Design: Module Vs not used	Cross circuit between channels of a channel group - not detected
MTA Design: Module Vs not used	Cross circuit between channels in different channel groups - not detected
MTA Design: Module Vs not used	There is no isolation between channels or between groups of channels.

13.11 Typical Transmitter Connection to Field Terminals

Figure 13–3 Field Terminal Connections for 12/24-Channel, 24 VDC F Discrete Input MTA

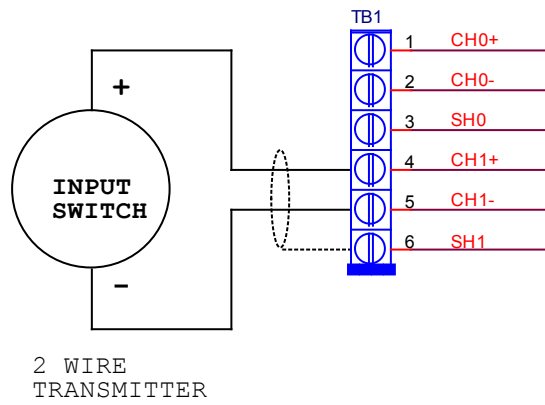

13.12 Hardware Configuration

The 12/24 channel Fail-Safe Discrete Input Module and its MTA support Redundant and Non-redundant operation.

13.12.1 Addresses

Non-redundant Operation

The choice of the Input Address and Process Image are left to the user.

Redundant Operation

Process Image should be set to something other than the default. The choice of the Input Address is left to the user.

Figure 13– shows a redundant configuration.

Figure 13–4 12/24-Channel Fail-Safe Discrete Input Hardware Configuration: Address set for Redundant Operation

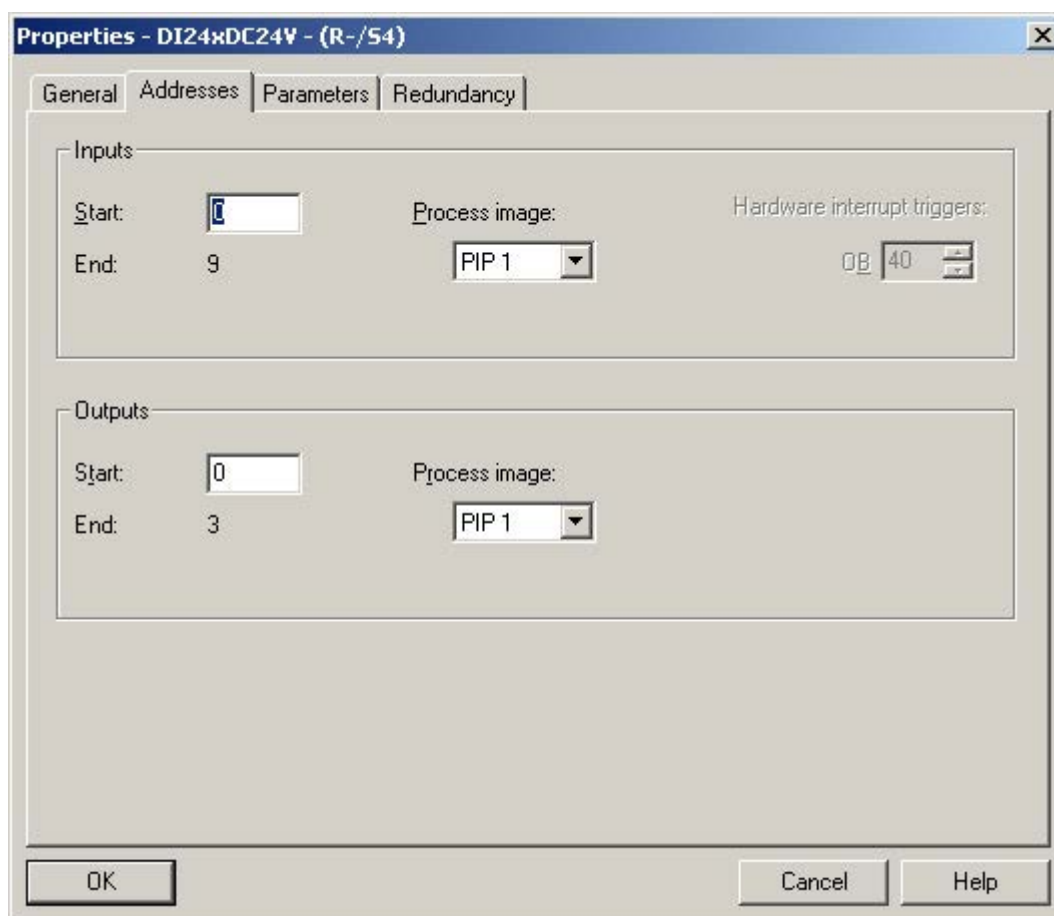

13.12.2 Parameters

The Parameters tab of the FDI Hardware Configuration has many options that can be set by the user.

The Operating mode should be set to the user preference: Standard operation or Safety mode.

The F parameters are viewable but not alterable.

Module parameters and Time-of-day stamp are described later.

Figure 13– the tree structure of the Parameters:

Figure 13–5 12/24-Channel Fail-Safe Discrete Input Hardware Configuration: Parameter Tree Structure

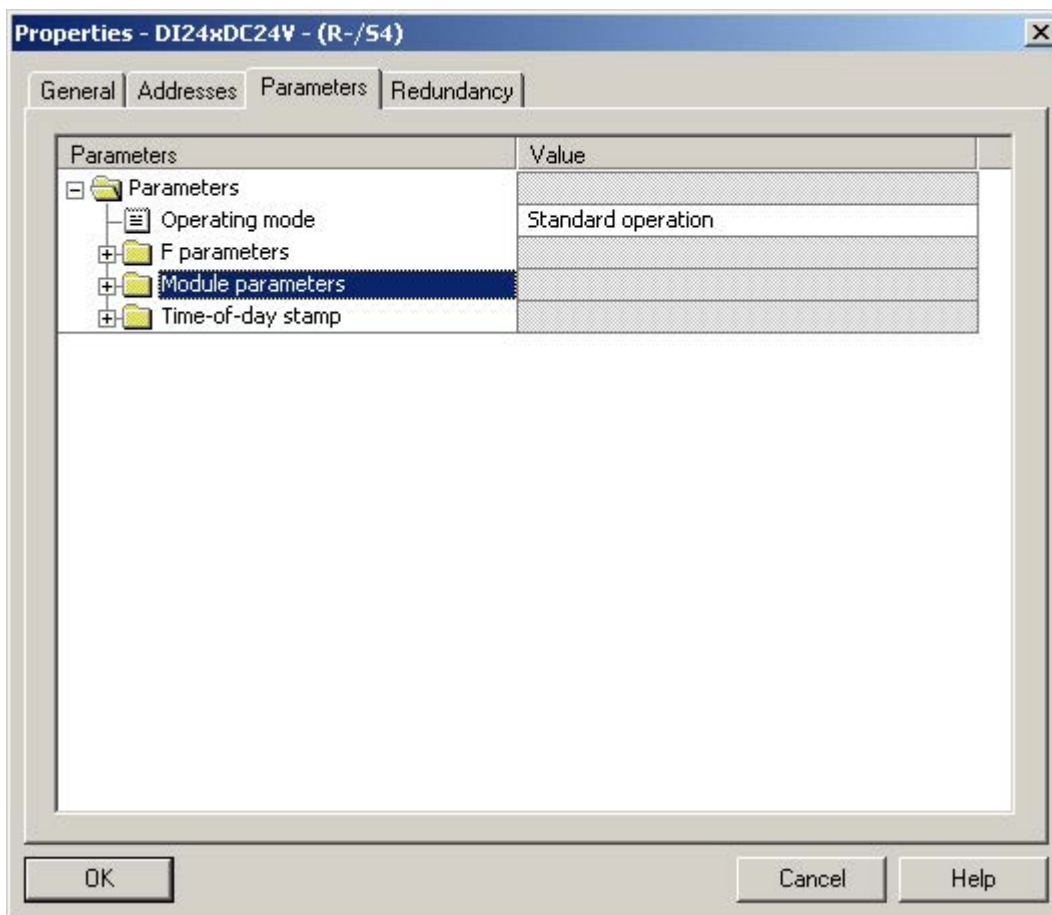

13.12.3 Module Parameters

Because of the MTA design some parameters must be set manually.

Encoder supply

The **Encoder supply via module** boxes for both **Supply group Vs1/Vs3** and **Supply group Vs2/Vs4** must **NOT** be checked because the sensor does not use the VS from the module as a power supply. As a result some diagnostic tests are unavailable. See Section 8.8, *IO Module Restrictions* for detailed information.

Other options

All other options should be set to user preferences.

Figure 13– shows the module set for Standard operation, VS1/VS3 Encoder supply NOT checked, and Channel 0, 12 activated.

Figure 13–6 12/24-Channel Fail-Safe Discrete Input Hardware Configuration: Parameter Settings

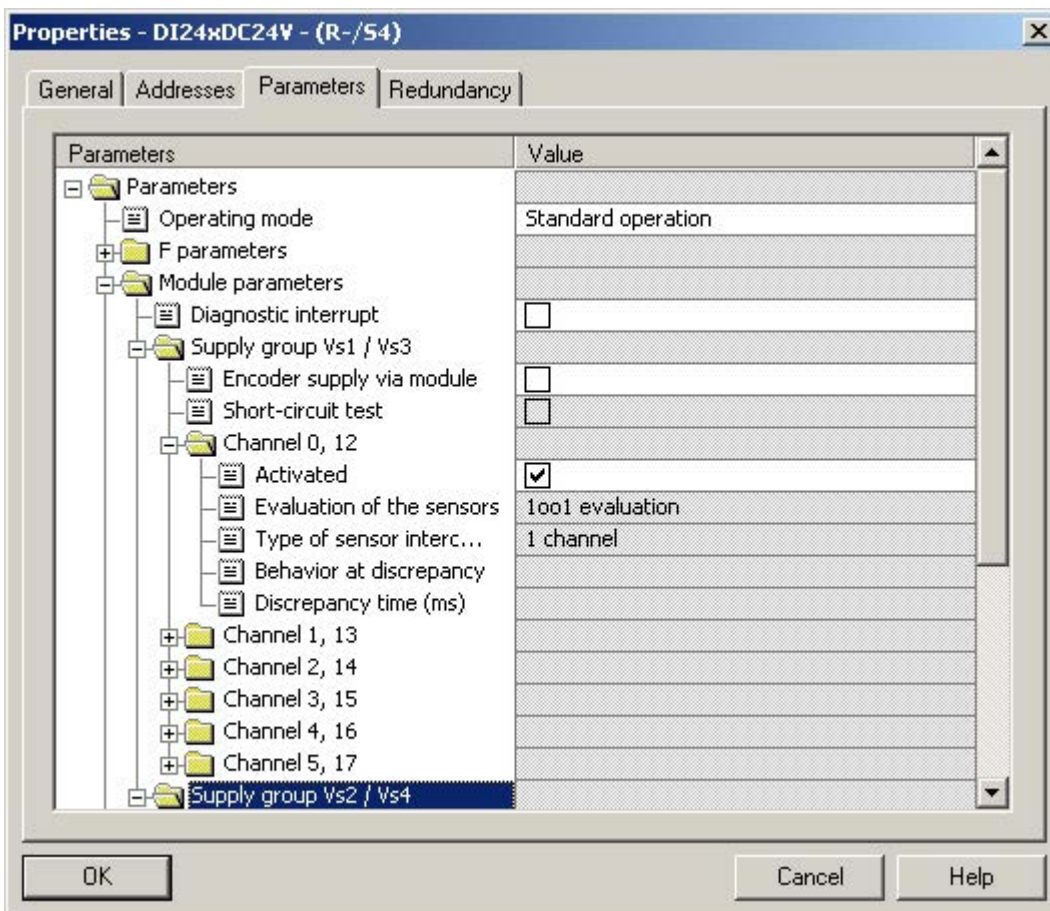

Time-of-day Stamp

All of these options should be set to the user preferences, as shown in Figure 13-.

Figure 13-7 12/24-Channel Fail-Safe Discrete Input Hardware Configuration: Parameters Time-of Day Stamp Settings

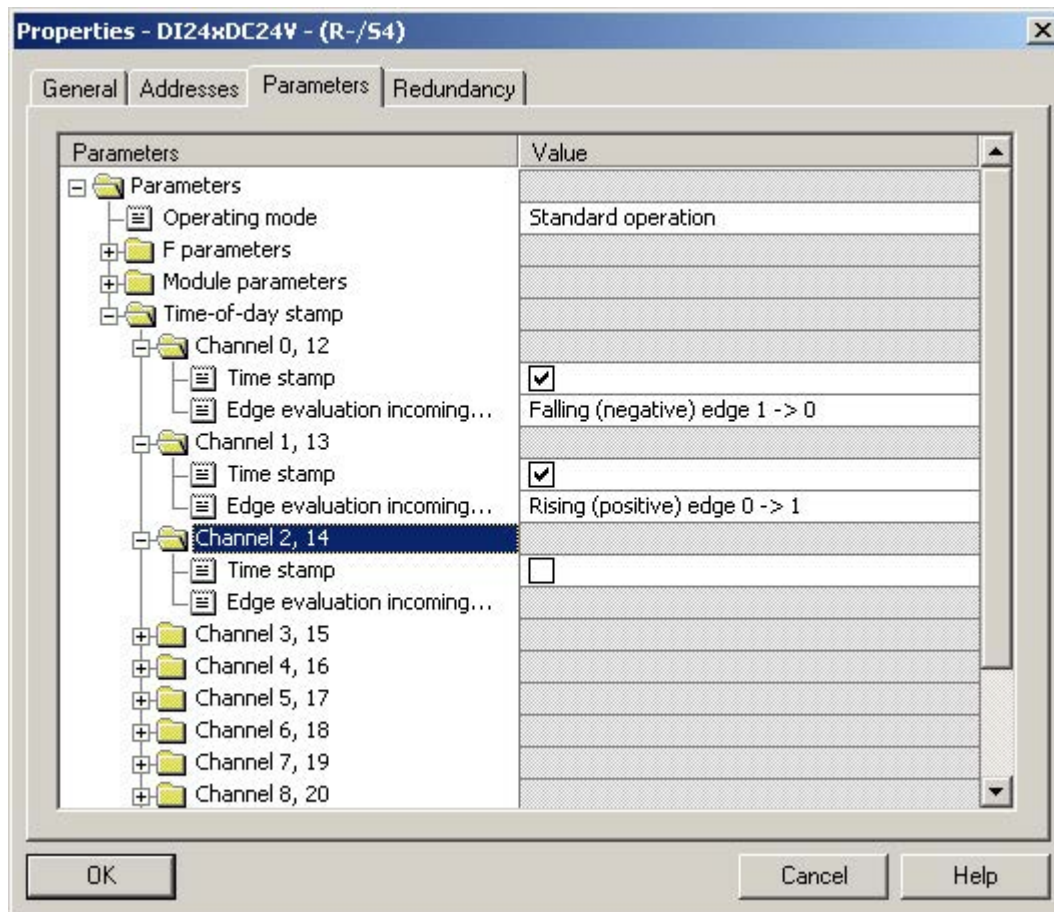

13.12.4 Redundancy

All of these options should be set to the user preferences.

Figure 13–shows a redundant FDI configuration.

Figure 13–8 12/24-Channel Fail-Safe Discrete Input Hardware Configuration: Redundancy Settings

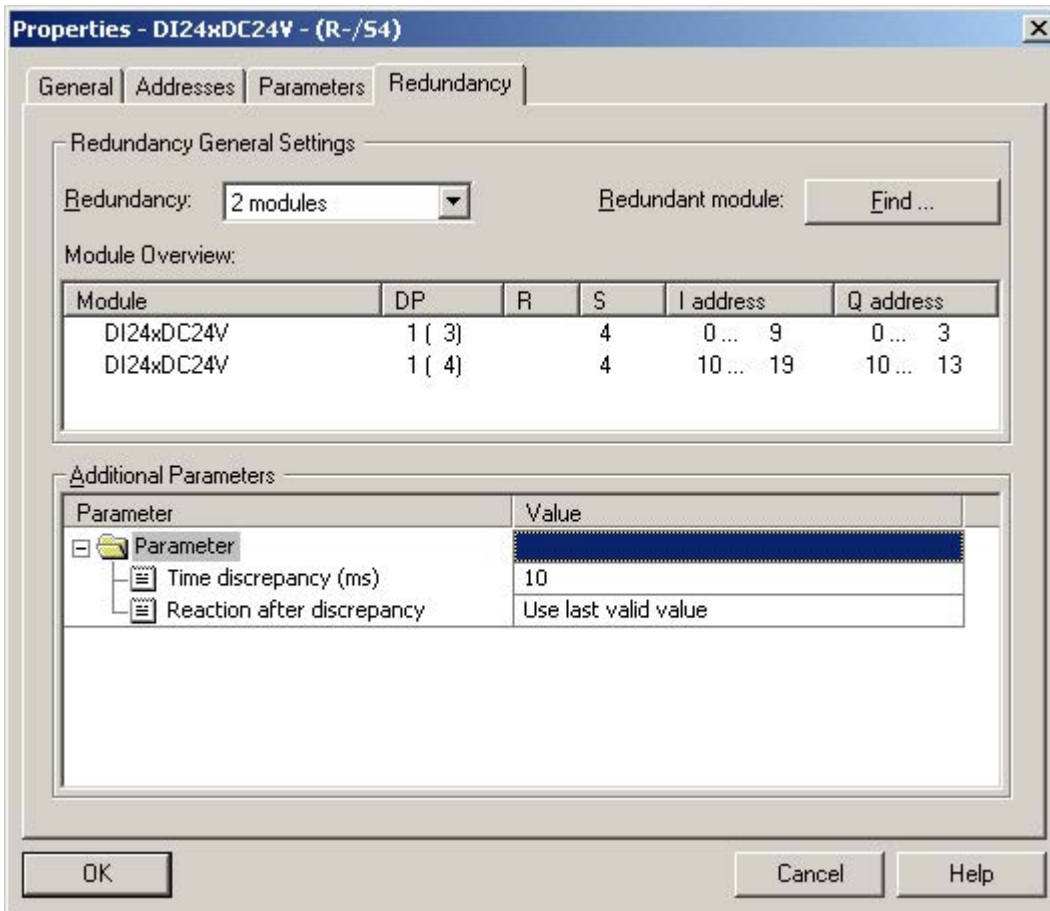

13.13 Technical Specifications for 12/24-Channel, 24 VDC F Discrete Input Module (6ES7 326-1BK00-0AB0 or 6ES7 326-1BK01-0AB0 or 6ES7 326-1BK02-0AB0)

Note

For a complete functional description and the most current technical specifications for this module, refer to the manual *S7-300 Automation System Fail-Safe Signal Modules* (document number A5E00085586).

14 10-Channel, 24 VDC F Discrete Output MTA

Part No. 6ES7650-1AL11-6XX0 or 6ES7650-1AL10-6XX0

14.1 Description

This section contains information and requirements to facilitate installation of Siemens Marshalled Termination Assembly (MTA) (6ES7650-1AL11-6XX0 or 6ES7650-1AL10-6XX0), designed to interface with the Siemens ET 200M 10-Channel, 24 VDC F Discrete Output module (6ES7 326-2BF10-0AB0, E-Stand 3 or higher).

Note: The only major difference between the two part numbers is the housing. The Anthracite Gray housing is the latest design. Functionality of both part numbers is the same.

14.2 Features

The following features have been incorporated into this MTA:

- Redundant power connections
- LED indication of redundant power supply condition
- Power monitor plug-in available (optional)
- Dual connectors for redundant I/O Module operation
- Per module power fusing
- Per channel fusing of field power
- Shield connections available for channel cabling
- Ground stud for connecting shield to earth ground
- Power input and field terminations are pluggable for easy maintenance

14.3 Operation

Power is supplied via the two removable power connectors which are retained by screws and marked **L+A, MA**, and **L+B, MB**. Each has a LED to indicate the presence of voltage over 15 VDC. The LEDs are marked **A POWER** and **B POWER**. There is also a connector (**J3**) for a Power Monitor board used to indicate the presence of both A and B power. See Section 19, *Power Monitor Board* (6ES7650-1BA02-0XX0).

Incoming power from **A** and **B** is diode OR'd, in **CR106**, to provide the MTA and the module power from either input source. The output from **CR106** is sent to the I/O modules via the module fuses and to the channels via the channel fuses. Module Fuse 1 (**F100**) supplies the I/O Module plugged into **J1** and Module Fuse 2 (**F101**) supplies power to the I/O Module plugged into **J2**.

Field Terminals, Channel + (**CHx+**), Channel – (**CHx-**), and Shield (**SHx**), connect to the field devices. **CHx+** is the Channel Output power source and is fused (1.0A) on a channel-by-channel basis. **CHx-** is the output device return. The field termination connector is removable for ease of wiring maintenance and is retained by friction.

The CHx+ connects to the I/O modules input via **J1** and **J2**. Redundant operation uses two modules with one each connected to **J1** and **J2**. Redundant operation is achieved by connecting the diode output from each channel on different modules together. Non-redundant systems have one module connected to either **J1** or **J2**.

Connection from the MTA to the I/O Module is accomplished with a 40 pin Siemens connector wired to a D25 female connector. This cable has larger wires than the other cables because of the higher current capabilities of the module.

14.4 Installation Requirements

See Section 2, *Installation*, before performing any installation and observe all warnings

A common interconnecting cable (6ES7922-3BD00-0AN0 or 6ES7922-3BJ00-0AN0), supporting Failsafe 10-channel Discrete outputs, interconnects the discrete output termination assembly to the 10-channel, 24 VDC discrete output module (6ES7 326-2BF10-0AB0, E-Stand 3 or higher).

Note

To disconnect the interconnecting cable shield from ground at the MTA only, cut and remove the shield disconnect jumper, **W100** and **W101**, for the associated cable.

14.5 Maintenance

See Section 3, *Maintenance*, before performing any maintenance and observe all warnings

Under normal operation, the **A/B Power LED** and the **Module 1/2 Fuse LED** are on. If all are off, check the power supply to MTA. If the **A/B Power LED** is off, check the power supply to the MTA. If the **Module 1/2 Fuse LED** is off, check and replace the module fuse.

14.6 Simplified diagram

Figure 14–1 12/24-Channel, 24 VDC F Discrete Output Marshalled Termination Assembly (6ES7650-1AL11-6XX0 or 6ES7650-1AL10-6XX0)

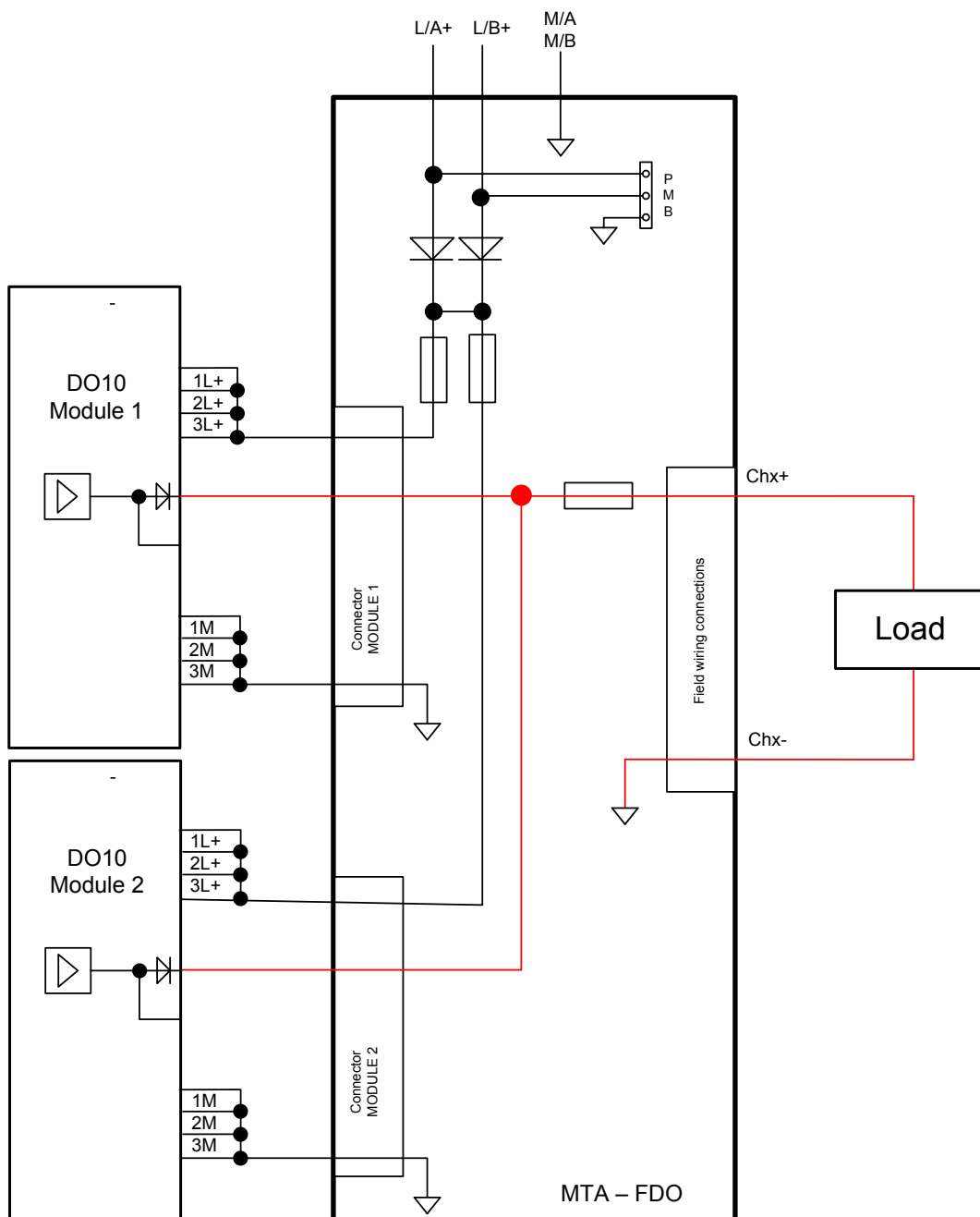

14.7 10-Channel, 24 VDC F Discrete Output Marshalled Termination Assembly

Figure 14–2 10-Channel, 24 VDC F Discrete Output Marshalled Termination Assembly (6ES7650-1AL11-6XX0 or 6ES7650-1AL10-6XX0)

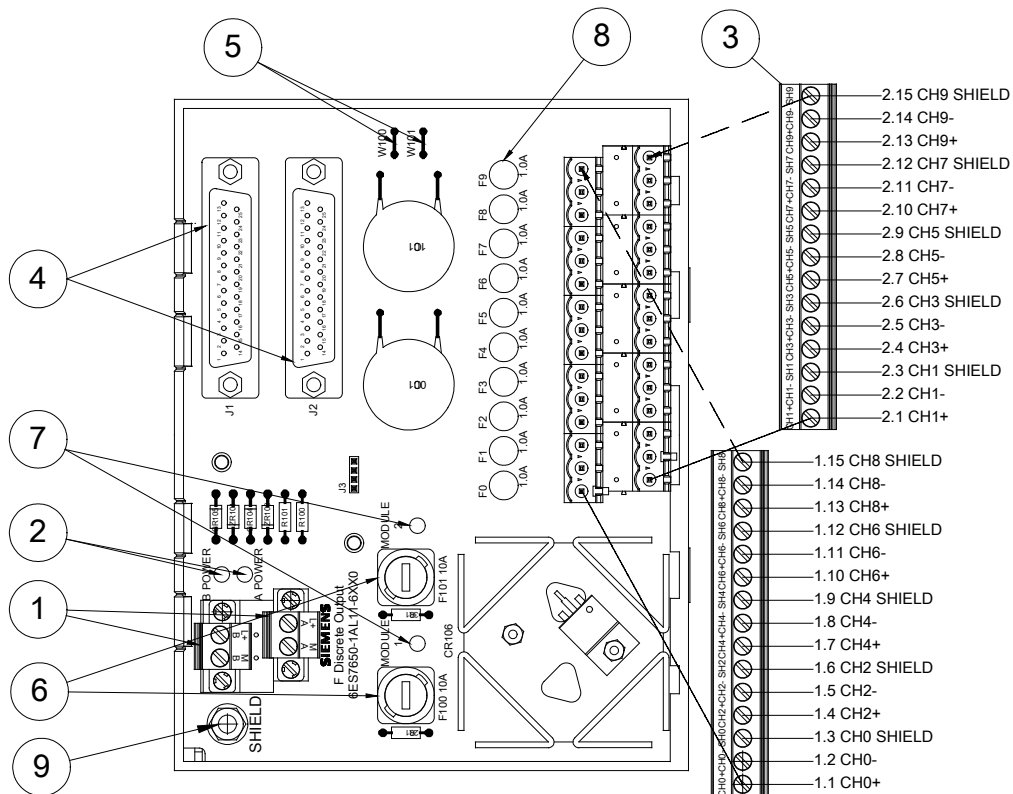

Key to numbered items in Figure 14–2:	
Item	Description
1	Input power connections
2	Input power indicators
3	Field wiring connections
4	I/O module connectors
5	Shield disconnect jumpers (W100 & W101)
6	Module power fuses
7	Module power indicators
8	Channel power fuse (1 of 10)
9	Shield Ground Stud for connecting to earth ground

14.8 Technical Specifications

Technical Specifications: 10-Channel, 24 VDC F Discrete Output MTA (6ES7650-1AL10-6XX0)	
Dimensions - See Section 1, Figure 1.3, Short Version	
Mounting	
DIN Rail	35mm (deep top hat style)
Power Input	
Voltage Input for Single or Redundant Feed	21.6 to 28.8 VDC
Current Consumption (nominal ratings; all channels connected)	
All outputs ON	10.570 A maximum
All outputs OFF	0.575 A normal
Power Dissipation (typical)	7 W
Terminal Block Wire Sizes	TB100 & TB101
Wire Size – US	24 – 14 gauge AWG
Wire Size – Metric	0,205 – 2,08 mm sq.
Power Supply Specifications	See Module Specs
Fuse Ratings	
Individual channel – Normal	1.0 A (Littelfuse P/N: 273 001) (Siemens Spare P/N: A5E01568884)
Individual channel – Optional	3.0 A (Littelfuse P/N: 273 003) ⁸
Module Power	10 A (Schurter P/N: 0034.1526) (Siemens Spare P/N: A5E01574409)
Indicators	
Input Power	Green LED on when input power available
Module Power	Green LED on when sensor power available
Channel Power	NA
Field Terminal Block Wire Sizes TB1 – TB2	
Wire Size – US	24 – 14 gauge AWG
Wire Size – Metric	0,205 – 2,08 mm sq.
Environmental	
Ambient Temperature	-25C to +60C
Humidity	5% to 95% Non-condensing
Approvals	
MTA Agency Approvals	See Preface section, Approvals Table
Max achievable Safety Integrity Level in safety mode	
In Accordance with IEC 61508	SIL 3

⁸ A 3.0 A fuse can be used but Group current and total channel current are limited. See module specifications under *Total current of the outputs with series diode* for more information

Technical Specifications: 10-Channel, 24 VDC F Discrete Output MTA (6ES7650-1AL10-6XX0)	
Fail-safe performance characteristics	(no dangerous undetected failures for DO MTA)
Low demand mode (average probability of failure on demand) per channel	PFDavg = 0
High Demand / continuous mode (probability of dangerous failure per hour per channel)	PFH = 0
Proof-test time	20 years

14.9 Technical Specifications

Technical Specifications: 10-Channel, 24 VDC F Discrete Output MTA (6ES7650-1AL11-6XX0)	
Dimensions - See Section 1, Figure 1.3, Short Version	
Mounting	
DIN Rail	35mm (deep top hat style)
Power Input	
Voltage Input for Single or Redundant Feed	21.6 to 28.8 VDC
Current Consumption (nominal ratings; all channels connected)	
All outputs ON	10.570 A maximum
All outputs OFF	0.575 A normal
Power Dissipation (typical)	7 W
Terminal Block Wire Sizes	TB100 & TB101
Wire Size – US	24 – 14 gauge AWG
Wire Size – Metric	0,205 – 2,08 mm sq.
Power Supply Specifications	See Module Specs
Fuse Ratings	
Individual channel – Normal	1.0 A (Littelfuse P/N: 273 001) (Siemens Spare P/N: A5E01568884)
Individual channel – Optional	3.0 A (Littelfuse P/N: 273 003) ⁹
Module Power	10 A (Schurter P/N: 0034.1526) (Siemens Spare P/N: A5E01574409)
Indicators	
Input Power	Green LED on when input power available
Module Power	Green LED on when sensor power available
Channel Power	NA

⁹ A 3.0 A fuse can be used but Group current and total channel current are limited. See module specifications under *Total current of the outputs with series diode* for more information

* Note derating table below

Technical Specifications: 10-Channel, 24 VDC F Discrete Output MTA (6ES7650-1AL11-6XX0)	
Field Terminal Block Wire Sizes TB1 – TB2	
Wire Size – US	24 – 14 gauge AWG
Wire Size – Metric	0,205 – 2,08 mm sq.
Environmental	
Ambient Temperature	-25C to +70C (Horizontal Mounting)* -25C to +60C (Vertical Mounting)*
Humidity	5% to 95% Non-condensing
Approvals	
Maximum achievable safety class in safety mode (depends on the voting of the corresponding I/O module)	
SIL according to IEC 61508, DIN EN 62061	SIL 3
Performance Level according to EN ISO 13849-1	PLe
Category according to EN ISO 13849-1	Cat. 4
Low Demand (PFD) according to SIL 3 (per channel)	0 (no dangerous undetected failures for DO MTA)
High Demand (PFH) according to SIL 3 (per channel)	0 1/h (no dangerous undetected failures for DO MTA)
Proof-test time	20 years

* Derating table

Mounting position	Maximum temperature	Total current across all channels
Horizontal	40 °C	10 A
	50 °C	7 A
	60 °C	6 A
	70 °C	4 A
Vertical	60 °C	6 A

Note

Fuses are available as spare parts from Siemens.

Fuse information can be found at:

<http://www.littelfuse.com>

<http://www.schurter.com>

14.10 Module Restrictions

Restrictions for 10-Channel, 24 VDC F Discrete Output MTA (6ES7650-1AL11-6XX0 or 6ES7650-1AL10-6XX0)	
I/O Module Restrictions	
Module Design - Diode Outputs used	See module specifications for limitations
MTA Design - Isolation	There is no isolation between channels or between groups of channels

14.11 Typical Load Connection to Field Terminals

Figure 14–3 Load Connection to Field Terminals of 10-Channel, 24 VDC F Discrete Output MTA

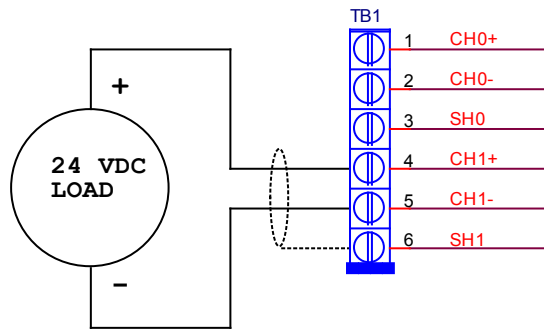

14.12 Hardware Configuration

The 10 channel Fail-Safe Discrete Output Module and its MTA support Redundant and Non-redundant operation.

14.12.1 Addresses

Non-redundant Operation

The choice of the Input Address and Process Image are left to the user.

Redundant Operation

Process Image should be set to something other than the default. The choice of the Input Address is left to the user.

Figure 14– is of a redundant configuration.

Figure 14-4 10-Channel Fail-Safe Discrete Output Hardware Configuration: Addresses for Redundant Operation

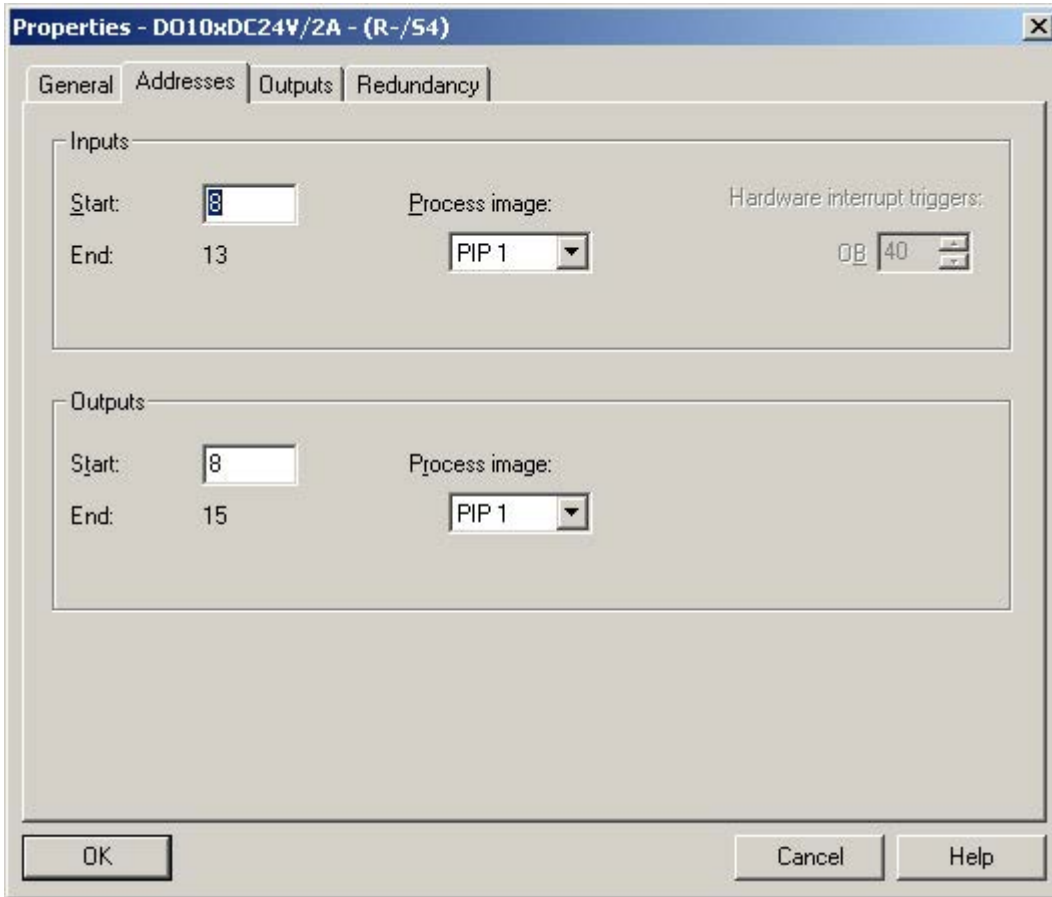

14.12.2 Outputs

The FDO MTA uses the series diode outputs from the FDO module for both redundant and non-redundant operation. This determines which diagnostics are generated. More information about these effects can be found in the *I/O Restrictions* section of the **Technical Specifications** table and the module specifications.

All options should be set for the user preferences.

Figure 14– shows the FDO configured for **Standard Mode** and all the diagnostics enabled.

Figure 14–5 10-Channel Fail-Safe Discrete Output Hardware Configuration: Outputs Configured for Standard Mode with all Diagnostics Enabled

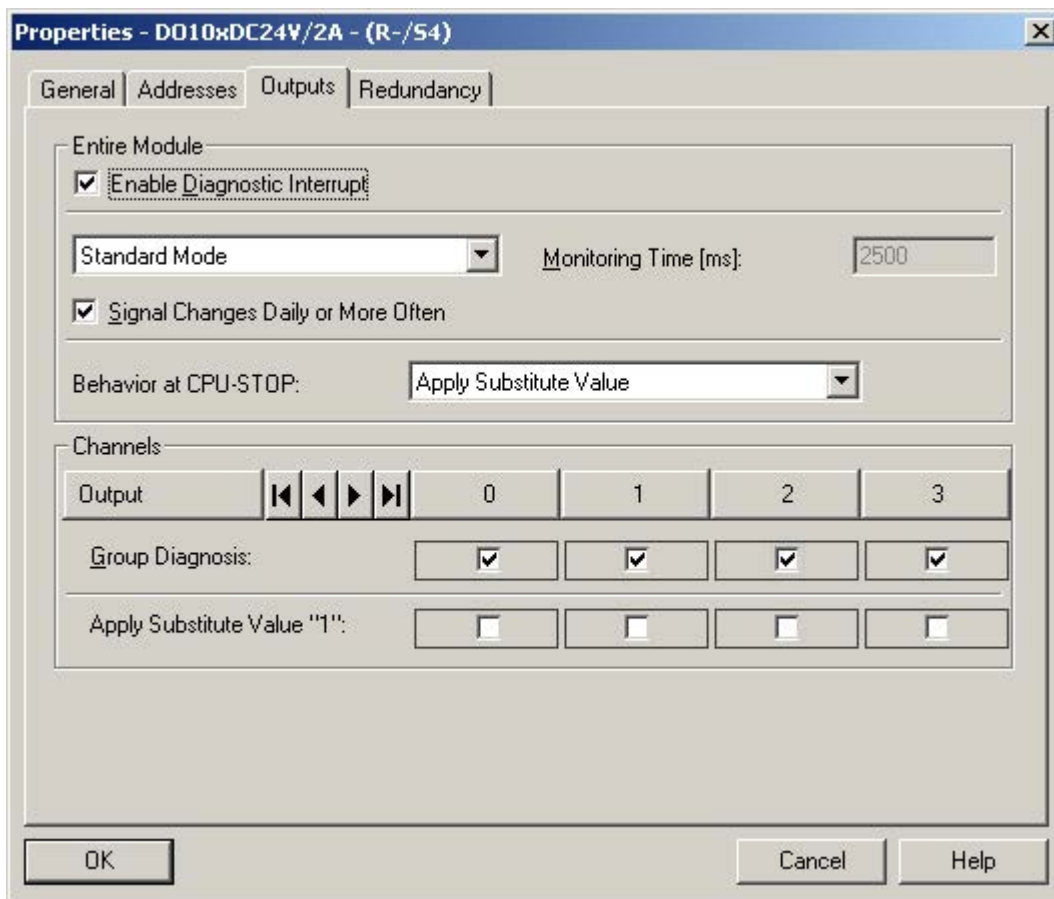

14.12.3 Redundancy

Figure 14– shows a redundant FDO configuration.

Figure 14–6 10-Channel Fail-Safe Discrete Output Hardware Configuration: Redundancy Selections

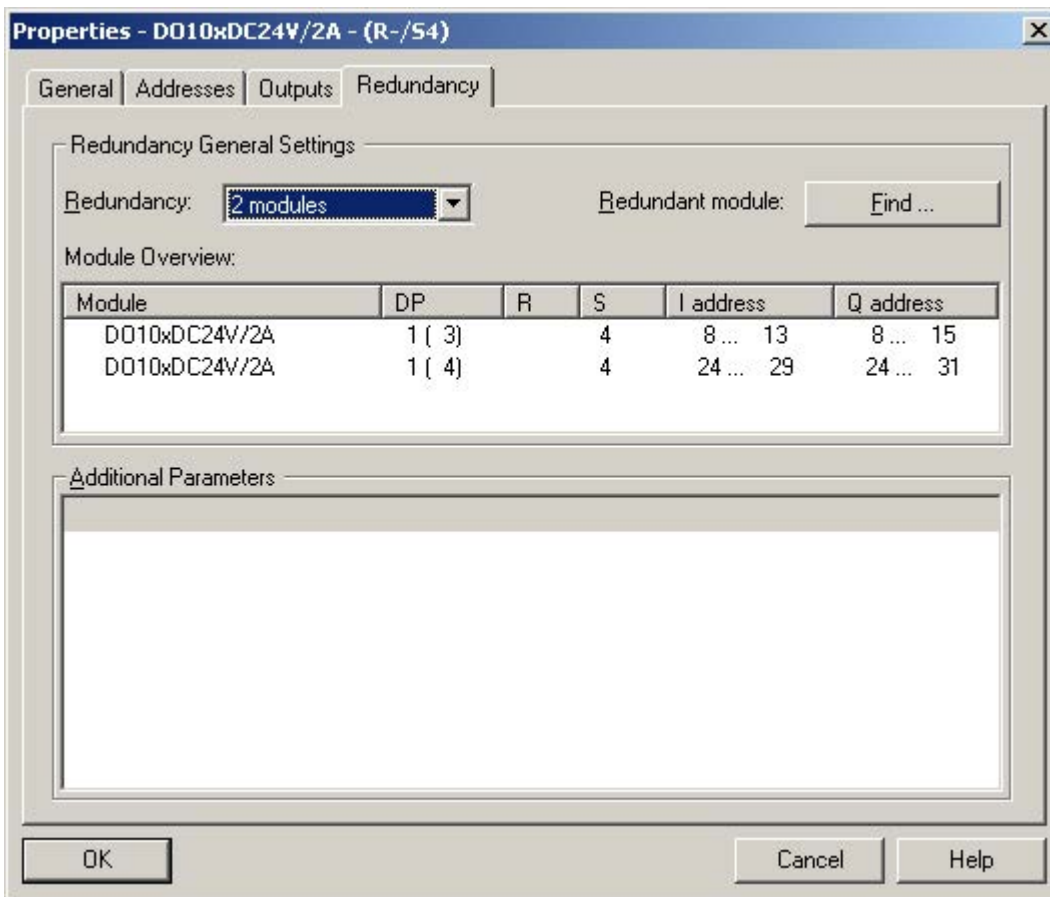

14.13 Technical Specifications for 10-Channel, 24 VDC F Discrete Output Module (6ES7 326-2BF10-0AB0)

Note

For a complete functional description and the most current technical specifications for this module, refer to the manual *S7-300 Automation System Fail-Safe Signal Modules* (document number A5E00085586).

15 16-Channel, 24 VDC Discrete Output MTA

Part No. 6ES7650-1AD10-2XX0

15.1 Description

This section contains information and requirements to facilitate installation of Siemens Marshalled Termination Assembly (MTA) (6ES7650-1AD10-2XX0), designed to interface with the Siemens ET 200M 16-Channel, 24 VDC Discrete Output module (6ES7 322-8BH01-0AB0, E-Stand 1 or higher).

15.2 Features

The following features have been incorporated into this MTA:

- Redundant power connections
- LED indication of redundant power supply condition
- Power monitor plug-in available (optional)
- Dual connectors for redundant I/O Module operation
- Per module power fusing
- Per channel LED indication of output status (ON or OFF)
- Shield connections available for channel cabling
- Ground stud for connecting shield to earth ground
- Power input and field terminations are pluggable for easy maintenance

15.3 Operation

Power is supplied via the removable power connector marked **L+A**, **MA**, and **L+B**, **MB**. Each has a LED to indicate the presence of voltage over 15 VDC. The LEDs are marked **A POWER** and **B POWER**. There is also a connector for a Power Monitor board used to indicate the presence of both A and B power. See Section 14 Power Monitor Board, (6ES7650-1BA02-0XX0).

Incoming power from **A** and **B** is diode OR'd to provide the MTA and the module power from either power source. The output from the dual diode is sent to the I/O modules via the module power fuses.

Field Terminals, Channel + (**CHx+**), Channel – (**CHx-**), and Shield (**SHx**), connect to the field devices. **CHx+** is connected through series diodes on the MTA to the output signal of each DO module (Module 1 and Module 2). **CHx-** is the field device return. The field termination connector is removable for ease of wiring maintenance.

Redundant operation uses two I/O modules. Redundant operation is achieved by connecting the channel outputs to the series diodes on the MTA. The MTA uses the channel outputs without series diodes from the I/O module.

Connection from the MTA to the I/O Module is accomplished with a 40 pin Siemens connector wired to a D25 male connector.



Caution

The heatsink can be over 100 °C. Avoid contact during servicing.

15.4 Installation Requirements

See Section 2, *Installation*, before performing any installation and observe all warnings

A common interconnecting cable (6ES7922-3BD00-0AT0 or 6ES7922-3BJ00-0AT0), supporting 16-Channel Discrete outputs, interconnects the discrete output termination assembly to the 16-channel, 24 VDC discrete output module (6ES7 322-8BH01-0AB0, E-Stand 1 or higher).

Note

To disconnect the interconnecting cable shield from ground at the MTA only, cut and remove the shield disconnect jumper for the associated cable. See Figure 15-1.

15.5

15.6 Maintenance

See Section 3, *Maintenance*, before performing any maintenance and observe all warnings

Under normal operation, the **A/B Power LEDs** and the **Module 1/2 Fuse LEDs** are on. If an **A/B Power LED** is off, check the power supply to the MTA. If a **Module 1/2 Fuse LED** is off, check and replace the module fuse.

15.7 Component Identification

Figure 15–1 16-Channel, 24 VDC Discrete Output Marshalled Termination Assembly (6ES7650-1AD10-2XX0)

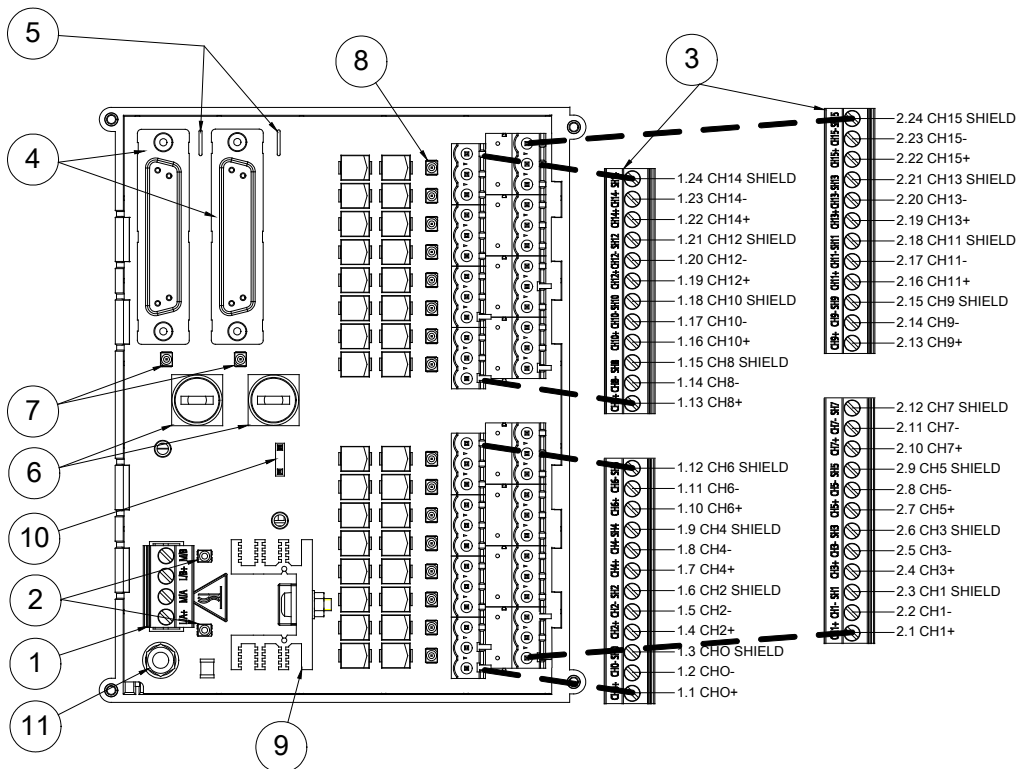

Key to numbered items in Figure 15–1:	
Item	Description
1	Input power connections (Power A, Power B)
2	Input power indicators (Power A, Power B)
3	Field wiring connections
4	I/O module connectors (Module 1, Module 2)
5	Shield disconnect jumpers (Module 1, Module 2)
6	Module power fuses, F17 and F18, (Module 1, Module 2)

Key to numbered items in Figure 15–1:	
Item	Description
7	Module power indicators (Module 1, Module 2)
8	Channel status indicators (1 of 16)
9	Heatsink
10	Connector for Power Monitor Board
11	Ground stud for connecting shield to earth ground

15.8 Technical Specifications

Technical Specifications: 16-Channel, 24 VDC Discrete Output MTA (6ES7650-1AD10-2XX0)	
Dimensions - See Section 1, Figure 1.3, Short Version	
Mounting	
DIN Rail	35mm (deep top hat style)
Orientation	horizontal or vertical
Power Input	
Voltage Input for Single or Redundant Feed	21.6 to 28.8 VDC
Current Consumption (nominal ratings)	
All outputs ON, maximum loads	8.3 A maximum
All outputs OFF	0.26 A maximum
Power Dissipation (typical)	10 W
Fuse Ratings	
Module	10 A/125V (Bussmann P/N: GMA-10A) (Siemens Spare P/N: A5E01568881) or (Schurter P/N: 0034.1526) (Siemens Spare P/N: A5E01574409)
Environmental	
Ambient Temperature	-25C to +60C
Humidity	5% to 95% Non-condensing
Approvals	
MTA Agency Approvals	See Preface section, Approvals Table
Indicators	
Input Power	Green LED on when input power available, Red LED on when power polarity is reversed
Module Power	Green LED on when module power available
Channel Status	Green LED on when channel is ON
Field Connections	
Wire Size – US / metric	24 to 14 AWG / 0.2 to 2.08 mm ²

Note

Fuses are available as spare parts from Siemens.

Fuse information can be found at:

<http://www.bussmann.com>

<http://www.schurterinc.com>

15.9 Changes to 16-Channel, 24 VDC Discrete Output Module (6ES7 322-8BH01-0AB0) Specifications

This section contains changes to the I/O module specifications when it is used with the MTA.

Changes to 16-Channel, 24 VDC Discrete Output Module (6ES7 322-8BH01-0AB0) Specifications when used with 16-Channel, 24 VDC Discrete Output MTA (6ES7650-1AD10-2XX0)	
Isolation between groups of 4 channels	No
Data for Selecting an Actuator - Voltage with output ON	L+ - 2.9 V minimum (L+ is supply voltage at the MTA)
Total current of outputs with series diodes	Not applicable, only outputs without series diodes are used. The total current per group is 2A max., as specified for the 6ES7322-8BH01 module. There are series diodes on the MTA; therefore the behavior of the 6ES7322-8BH01 module is like using outputs with serial diodes. This affects the applications with lamp loads and short circuit diagnostics. See 6ES7322-8BH01 module manual.
Reverse polarity power supply protection	Yes, see Note below.
Diagnostic with short circuit between the channel output and M (common)	If output signal = "0", the M short circuit diagnostic message is not reported.
Diagnostic with short circuit between the channel output and L+ (24V supply)	A short circuit between the channel output and L+ produce a "wire break" diagnostic message.

Note

Connecting one reverse polarity power supply (e.g. -24 VDC to L+A) and one correct polarity power supply (e.g. +24 VDC to L+B) will damage the MTA.

15.10 Technical Specifications for 16-Channel, 24 VDC Discrete Output Module (6ES7 322-8BH01-0AB0)

Note

For a complete functional description and the most current technical specifications for this module, refer to the manual SIMATIC ET 200M Signal Modules for Process Automation (document number A5E00085262-4, Edition 10/2004, Entry ID: 7215812).

15.11 Typical Load Connection to Field Terminals

Figure 15–2 Load Connection to Field Terminals of 16-Channel, 24 VDC Discrete Output MTA

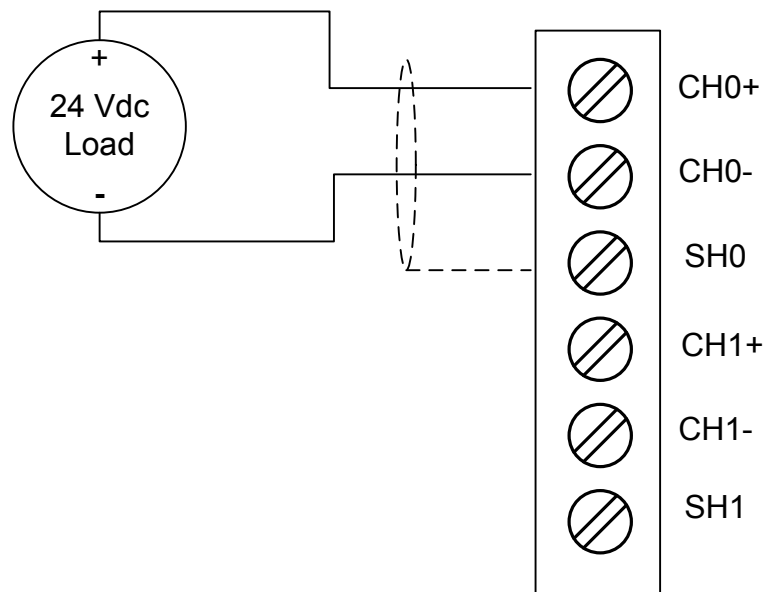

15.12 Hardware Configuration

The 16-Channel Discrete Output Module and its MTA support redundant and non-redundant operation.

15.12.1 Addresses

Non-redundant Operation

The choice of the Input Address and Process Image are left to the user.

Redundant Operation

Process Image should be set to something other than the default. The choice of the Input Address is left to the user.

Figure 15–3 16-Channel Discrete Output Hardware Configuration: Addresses for Redundant Operation

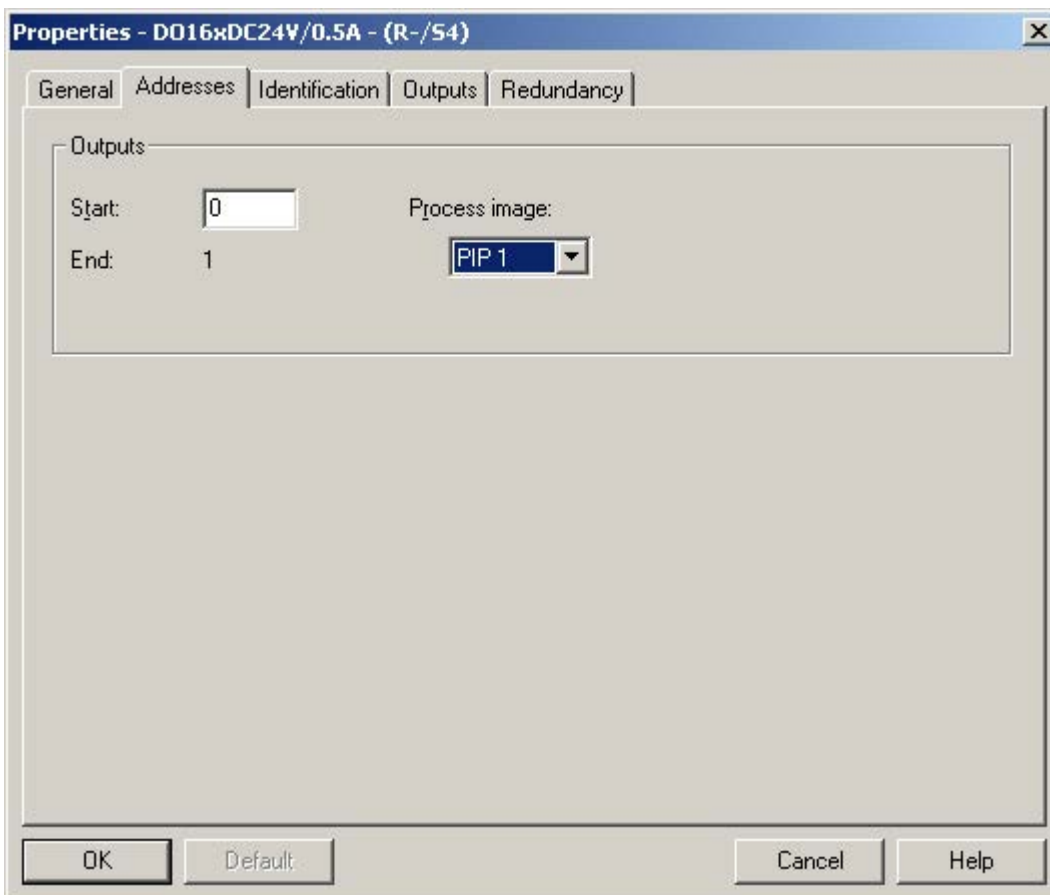

15.12.2 Outputs

All options should be set for the user preferences.

Figure 15-4 16-Channel Discrete Output Hardware Configuration: Outputs Configured with all diagnostics enabled

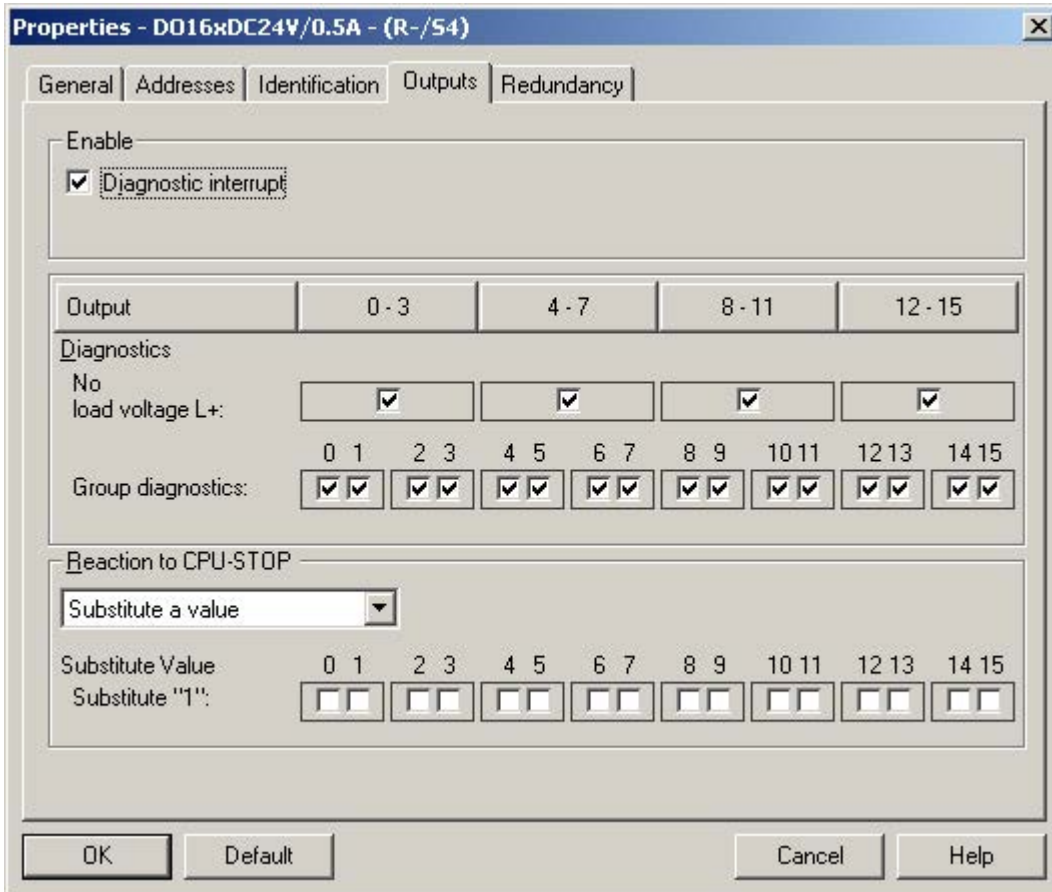

15.12.3 Redundancy

Figure 15–5 16-Channel Discrete Output Hardware Configuration: Redundancy Selections

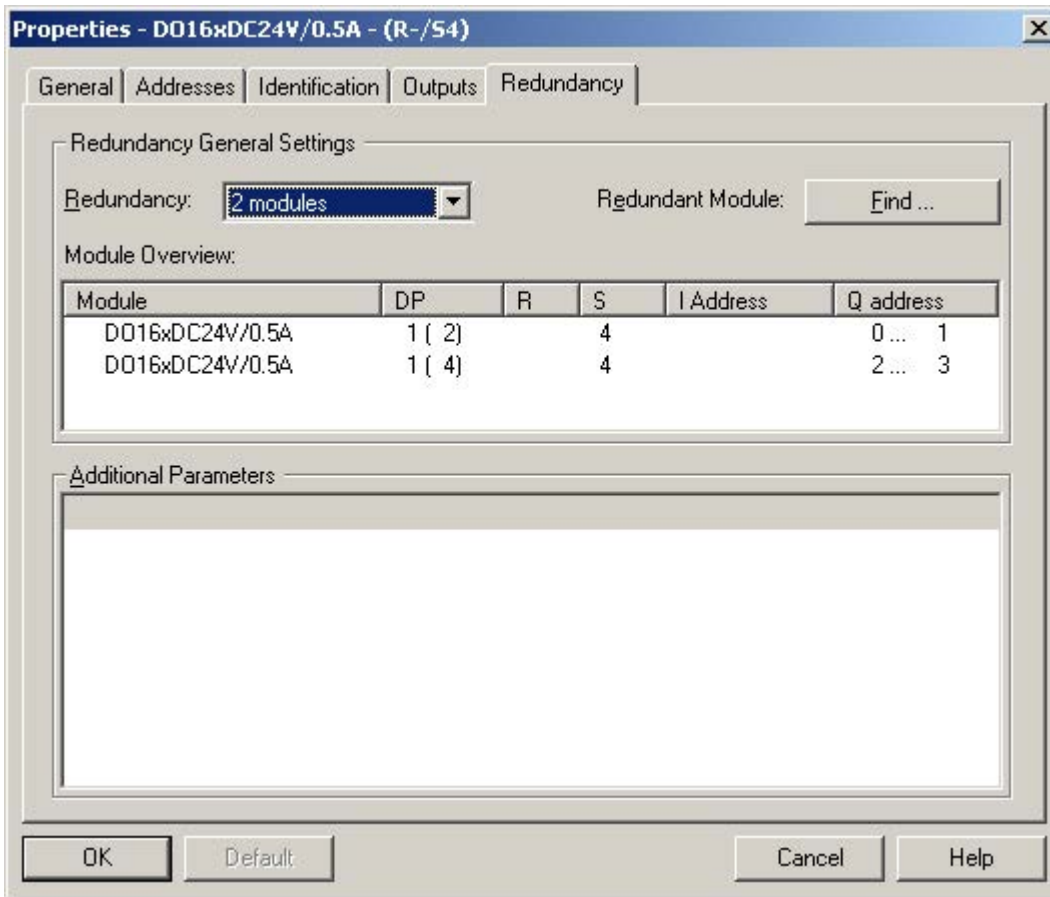

16 16-Channel, 24 VDC Discrete Output MTA

Part No. 6ES7650-1AD11-2XX0

16.1 Description

This section contains information and requirements to facilitate installation of Siemens Marshalled Termination Assembly (MTA) (6ES7650-1AD11-2XX0), designed to interface with the Siemens ET 200M 16-Channel, 24 VDC Discrete Output module (6ES7 322-8BH10-0AB0).

16.2 Features

The following features have been incorporated into this MTA:

- Redundant power connections
- LED indication of redundant power supply condition
- LED indication of reverse polarity
- Power monitor output
- Dual connectors for redundant I/O Module operation
- Per module power fusing
- Per channel LED indication of output status (ON or OFF)
- Shield connections available for channel cabling
- Ground stud for connecting shield to earth ground

16.3 Operation

Power is supplied via the removable power connector marked **L+A**, **MA**, and **L+B**, **MB**. Each has a green LED to indicate the presence of voltage over 15 VDC. The case of polarity reversal of the power supply is indicated by the LEDs illuminating red. The LEDs are marked **A POWER** and **B POWER**.

Incoming power from **A** and **B** is diode OR'd to provide the MTA and the module power from either power source. The output from the dual diode is sent to the I/O modules via the module power fuses.

An onboard Power Monitor System (PMS) is used to provide an isolated dry contact when redundant power is supplied to MTAs. Only when power is supplied to both power inputs the output contacts **1** and **2** are closed. The Power Monitor System is designed to detect only the presence or absence of power. It is not designed to detect supply voltage which is outside the specification threshold.

Field Terminals, Channel + (**CHx+**), Channel – (**CHx-**), and Shield (**SHx**), connect to the field devices. **CHx+** is connected to the output signal of each DO module (Module 1 and Module 2). The necessary diode decoupling for the output signals is realized onboard the Digital Output Module DO16xDC24V/0,5A and not on the MTA. **CHx-** is the field device return.

Redundant operation uses two Digital Output Modules.

Connection from the MTA to the I/O Module is accomplished with a 40 pin Siemens connector wired to a D25 male connector.



Caution

The heat sink can be over 100 °C. Avoid contact during servicing.

16.4 Installation Requirements

See Section 2, *Installation*, before performing any installation and observe all warnings

A common interconnecting cable (6ES7922-3BD00-0AT0 or 6ES7922-3BJ00-0AT0), supporting 16-Channel Discrete outputs, interconnects the discrete output termination assembly to the 16-channel, 24 VDC discrete output module (6ES7 322-8BH10-0AB0).

Note

To disconnect the interconnecting cable shield from ground at the MTA only, cut and remove the shield disconnect jumper for the associated cable. See Figure 15–1.

16.5 Maintenance

See Section 3, *Maintenance*, before performing any maintenance and observe all warnings

Under normal operation, the **A/B Power LEDs** and the **Module 1 or 2 Fuse LEDs** are green illuminated. If an **A/B Power LED** is red illuminated or off, check the power supply to the MTA. If a **Module 1 or 2 Fuse LED** is off, check and replace the module fuse.

Note

Status LED

With a normally connected load, the green Status LED is on when the channel is switched ON, and OFF when the channel is switched off.

The green Status LED is also on when the channel is switched OFF and not connected to the external load (wire break is indicated in module diagnostic).

The illumination of the LED in OFF-status (when the channel is not connected to the load) can be avoided when a resistor of 10k Ohm is connected between Chx+ and Chx-. In this case the module does not provide wire break diagnostic on that channel.

16.6 Simplified diagram

Figure 166-1 16-Channel, 24 VDC Discrete Output Marshalled Termination Assembly (6ES7650-1AD11-2XX0)

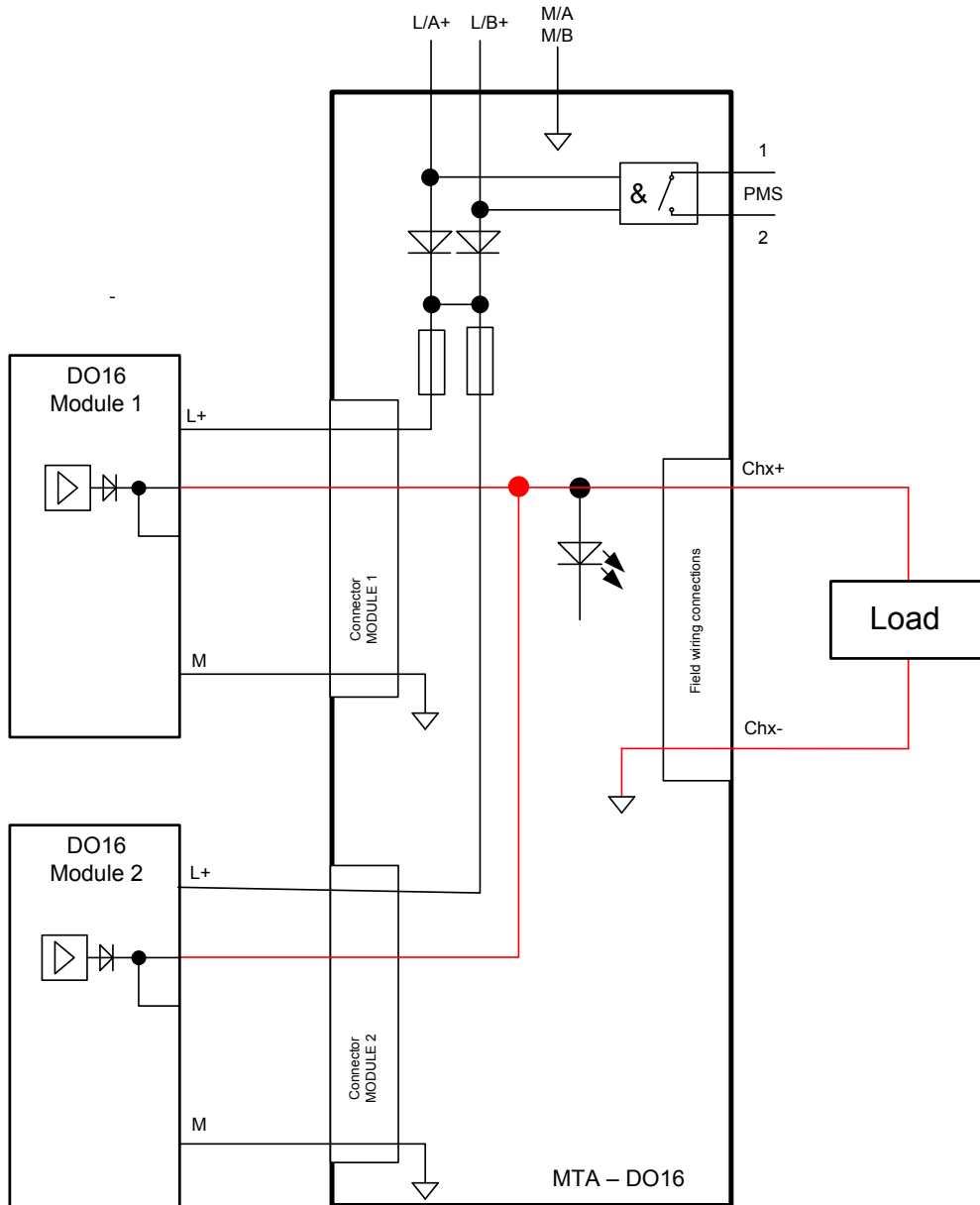

16.7 Component Identification

Figure 166-2 16-Channel, 24 VDC Discrete Output Marshalled Termination Assembly (6ES7650-1AD11-2XX0)

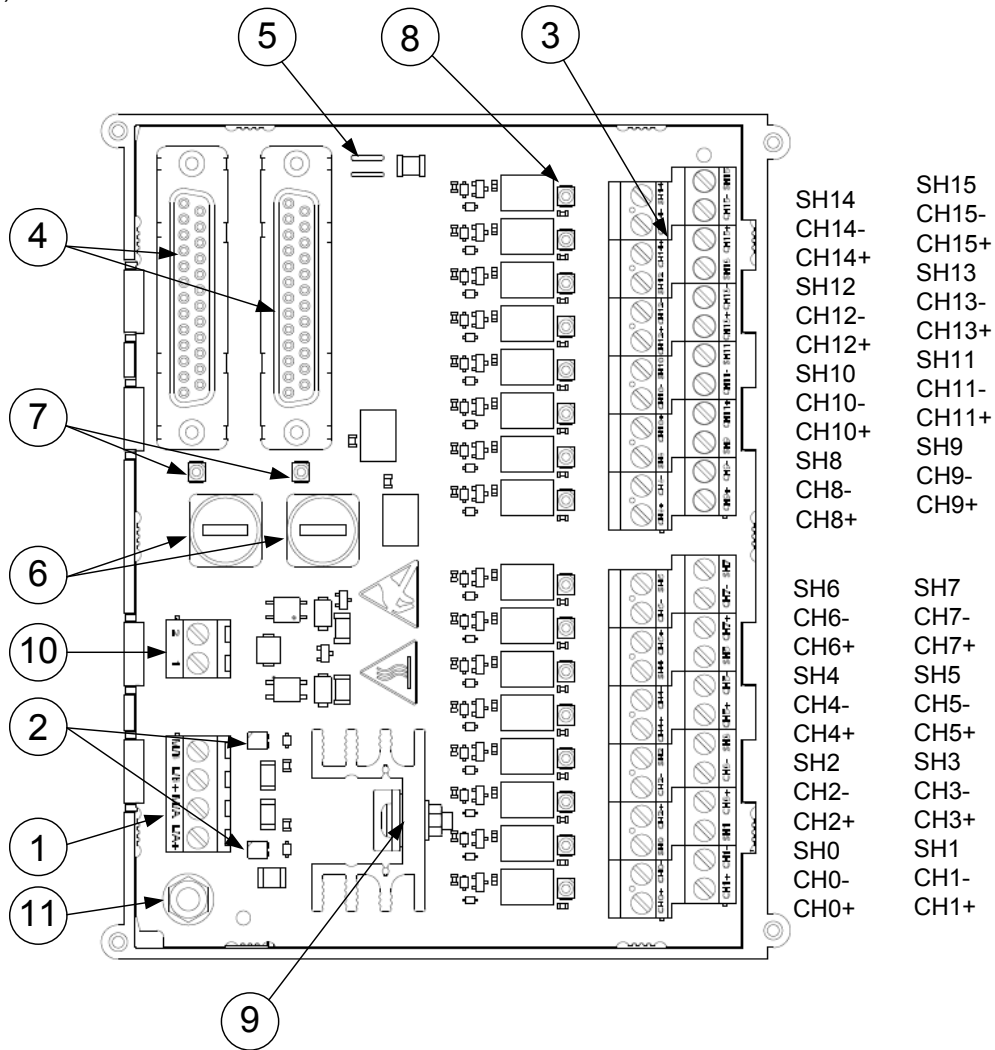

Key to numbered items in Figure 15-1:	
Item	Description
1	Input power connections (Power A, Power B)
2	Input power indicators (Power A, Power B)
3	Field wiring connections
4	I/O module connectors (Module 1, Module 2)
5	Shield disconnect jumpers (Module 1, Module 2)
6	Module power fuses, F17 and F18, (Module 1, Module 2)
7	Module power indicators (Module 1, Module 2)
8	Channel status indicators (1 of 16)
9	Heat sink

Key to numbered items in Figure 15-1:	
Item	Description
10	Output Power Monitor System
11	Ground stud for connecting shield to earth ground

16.8 Technical Specifications

Technical Specifications: 16-Channel, 24 VDC Discrete Output MTA (6ES7650-1AD11-2XX0)	
Dimensions - See Section 1, Figure 1.3, Short Version	
Mounting	
DIN Rail	35mm (deep top hat style)
Orientation	horizontal or vertical
Power Input	
Voltage Input for Single or Redundant Feed	21.6 to 28.8 VDC
Current Consumption (nominal ratings)	
All outputs ON, maximum loads	8.3 A maximum
All outputs OFF	0.26 A maximum
Power Dissipation (typical)	7 W
Fuse Ratings	
Module	10 A/125V (Bussmann P/N: GMA-10A) (Siemens Spare P/N: A5E01568881) or (Schurter P/N: 0034.1526) (Siemens Spare P/N: A5E01574409)
Environmental	
Ambient Temperature	-25C to +60C
Humidity	5% to 95% Non-condensing
Approvals	
MTA Agency Approvals	See Preface section, Approvals Table
Power Monitoring System - Optorelay Output Contact Ratings	
Threshold voltage	ca. 15 V
Maximum switched Voltage	30 V DC
Maximum switched Current	0.5 A resistive load; not short circuit proofed
Indicators	
Input Power	Green LED on when input power available, Red LED on when power polarity is reversed
Module Power	Green LED on when module power available
Channel Status	Green LED
Field Connections	
Wire Size – US / metric	24 to 14 AWG / 0.2 to 2.08 mm ²

Note

Fuses are available as spare parts from Siemens.

Fuse information can be found at:

<http://www.bussmann.com>

<http://www.schurterinc.com>

16.9 Changes to 16-Channel, 24 VDC Discrete Output Module (6ES7 322-8BH10-0AB0) Specifications

This section contains changes to the I/O module specifications when it is used with the MTA.

Changes to 16-Channel, 24 VDC Discrete Output Module (6ES7 322-8BH10-0AB0) Specifications when used with 16-Channel, 24 VDC Discrete Output MTA (6ES7650-1AD11-2XX0)	
Isolation between groups of 4 channels	No
Data for Selecting an Actuator - Voltage with output ON	L+ - 2.9 V minimum (L+ is supply voltage at the MTA)
Reverse polarity power supply protection	Yes, see Note below.
Short to P diagnostic	Is suppressed with redundancy selection

Note

Connecting one reverse polarity power supply (e.g. -24 VDC to L+A) and one correct polarity power supply (e.g. +24 VDC to L+B) will damage the MTA.

16.10 Technical Specifications for 16-Channel, 24 VDC Discrete Output Module (6ES7 322-8BH10-0AB0)

Note

For a complete functional description and the most current technical specifications for this module, refer to the manual SIMATIC S7-300 Module Data (document number A5E00105504-7, Edition 03/2011, Entry ID: 22091986).

16.11 Typical Load Connection to Field Terminals

Figure 166-3 Load Connection to Field Terminals of 16-Channel, 24 VDC Discrete Output MTA

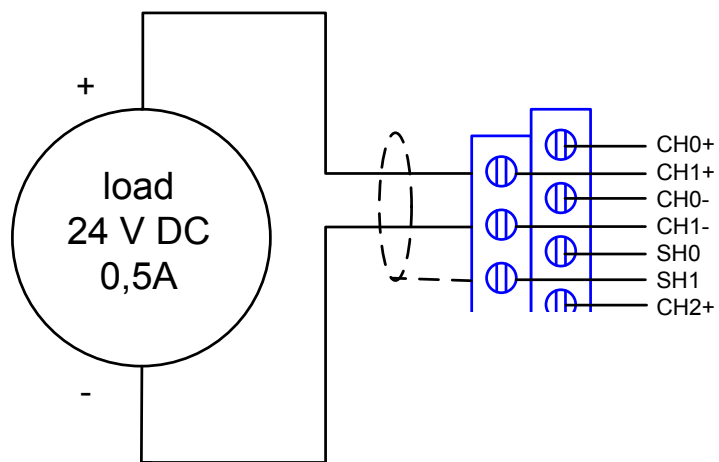

16.12 Hardware Configuration

The 16-Channel Discrete Output Module and its MTA support redundant and non-redundant operation.

16.12.1 Addresses

Non-redundant Operation

The choice of the Input Address and Process Image are left to the user.

Redundant Operation

Process Image should be set to something other than the default. The choice of the Input Address is left to the user.

Figure 166–4 16-Channel Discrete Output Hardware Configuration: Addresses for Redundant Operation

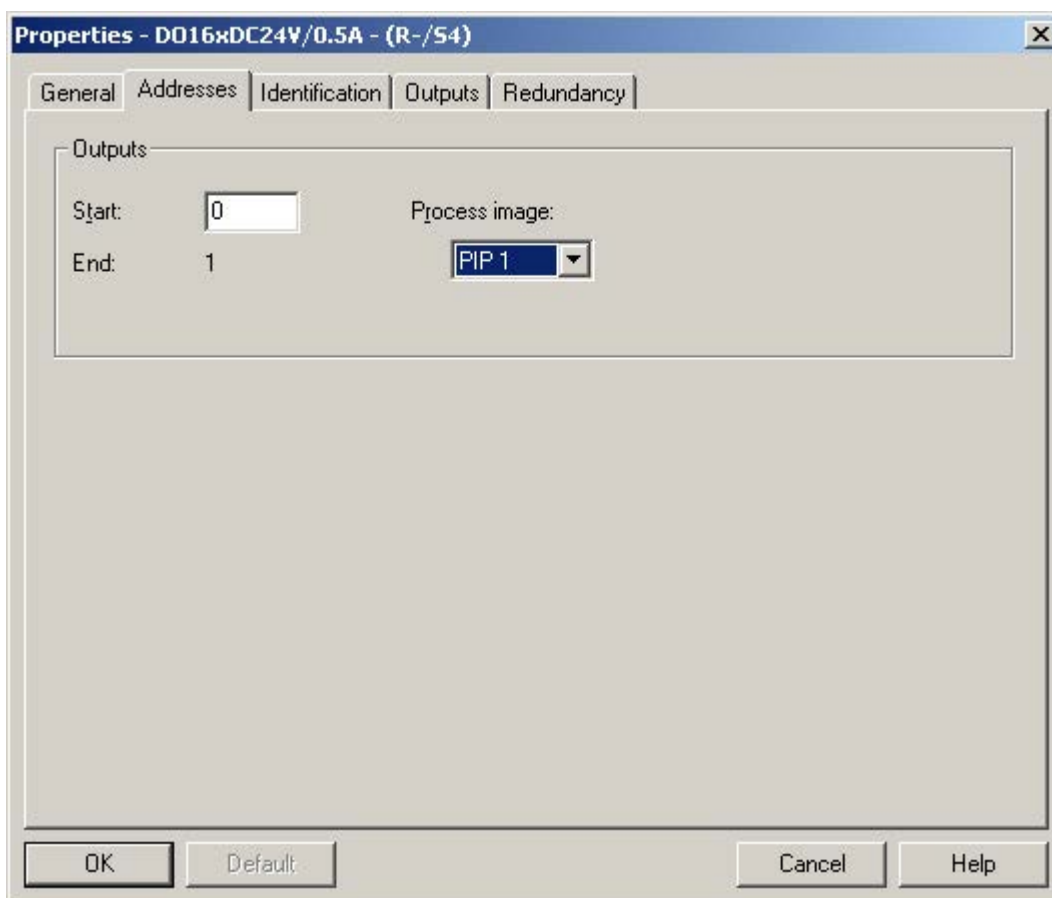

16.12.2 Outputs

All options should be set for the user preferences.

Figure 166–5 16-Channel Discrete Output Hardware Configuration: Outputs Configured with all diagnostics enabled

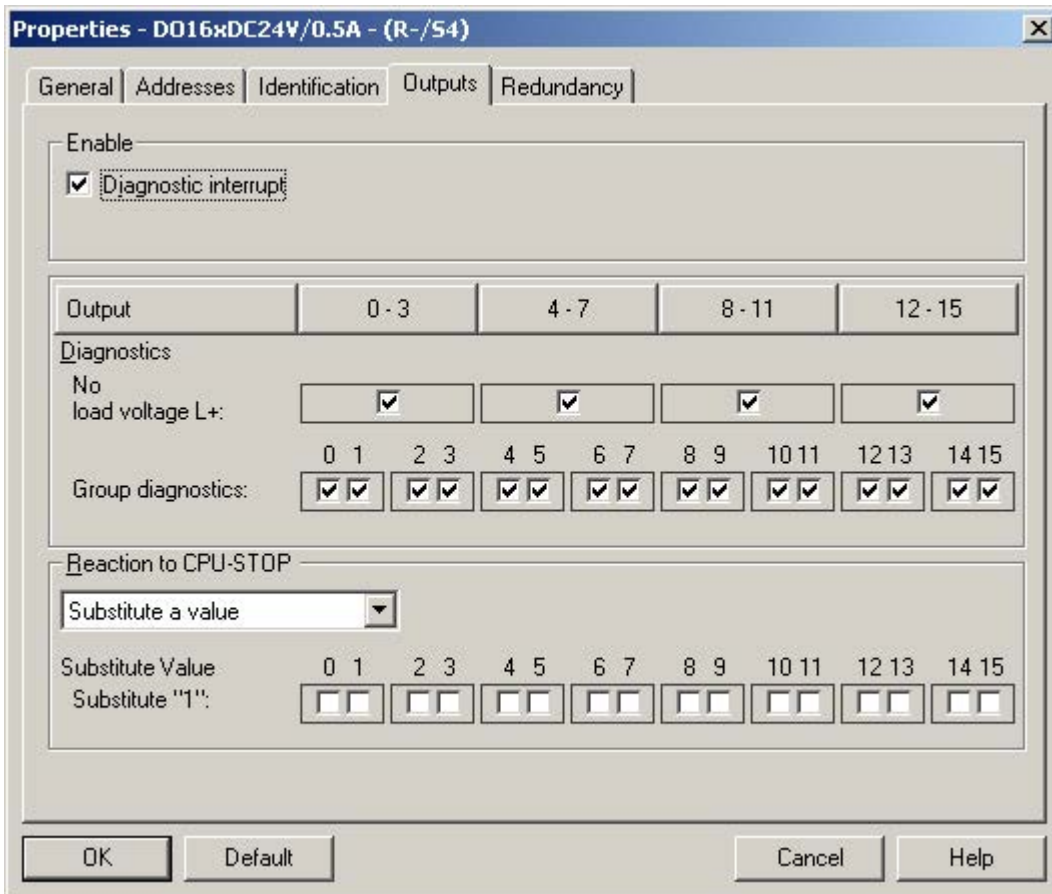

16.12.3 Redundancy

Figure 166-6 16-Channel Discrete Output Hardware Configuration: Redundancy Selections

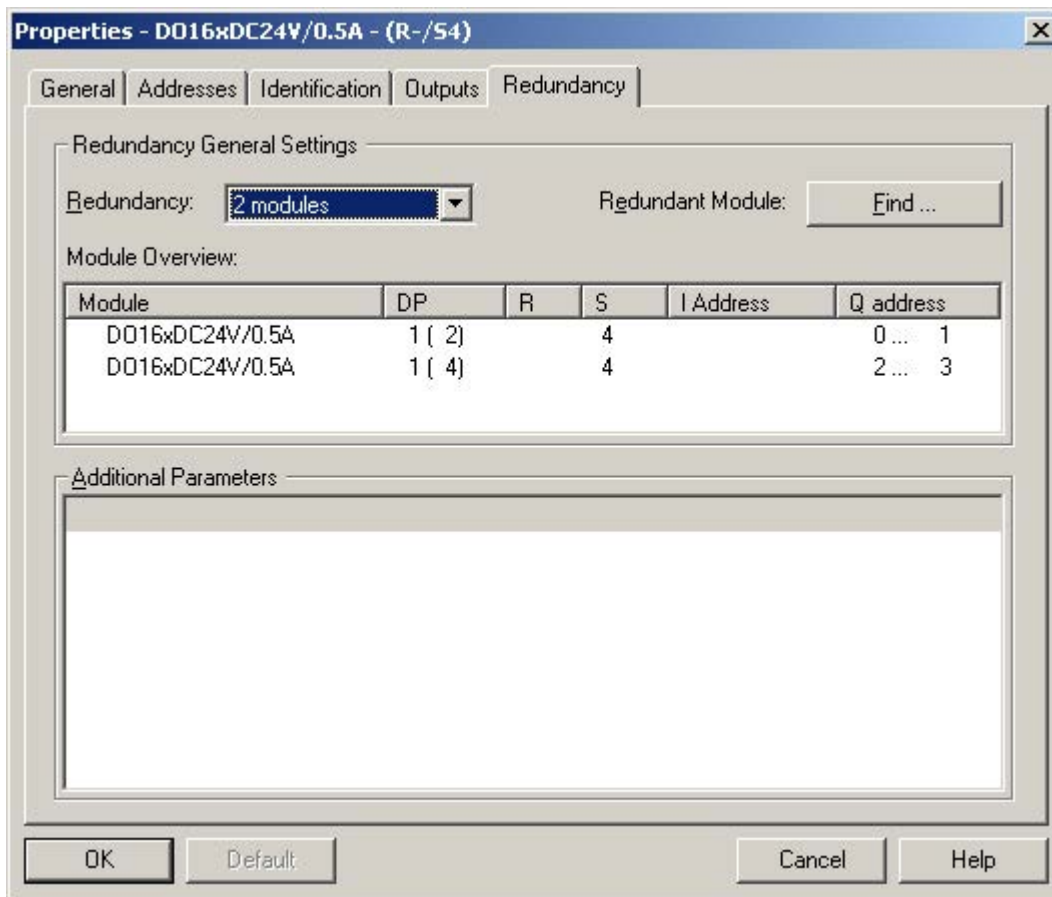

17 Failsafe 10-Channel, 24-150 VDC/120-230 VAC Relay Output MTA

Part No. 6ES7650-1AM31-6XX0 or 6ES7650-1AM30-6XX0

17.1 Description

This section contains information and requirements to facilitate installation of Siemens, 24-150 VDC/120-230 VAC Relay Output Marshalled Termination Assembly (MTA) (6ES7650-1AM31-6XX0 or 6ES7650-1AM30-6XX0), designed to interface with the Siemens ET 200M 10-Channel Failsafe Discrete Output Module (6ES7 326-2BF10-0AB0, E-Stand 3 or higher).

Note: The only major difference between the two part numbers is the housing. The Anthracite Gray housing is the latest design. Functionality of both part numbers is the same.

17.2 Features

The following features have been incorporated into this MTA:

- Form C Relay for each output
- Redundant power connections
- LED indication of redundant power supply condition
- Power monitor plug-in available (optional)
- Dual connectors for redundant I/O Module operation
- Per module power fusing
- Ground stud for connecting shield to earth ground
- Power input and field terminations are pluggable for easy maintenance

17.3 Operation

Power is supplied via the two removable power connectors which are retained by screws and marked **L+A, MA**, and **L+B, MB**. Each has a LED to indicate the presence of voltage over 15 VDC. The LEDs are marked **A POWER** and **B POWER**. There is also a connector for a Power Monitor board used to indicate the presence of both A and B power. See Section 19, *Power Monitor Board (6ES7650-1BA02-0XX0)*.

Incoming power from **A** and **B** is diode OR'd to provide the MTA and the module power from either input source. The output is sent to the I/O modules via the module fuses and to the channels via the channel fuses. Module 1 Fuse supplies the I/O Module plugged into the **Module 1 connector** and Module 2 Fuse 2 supplies power to the I/O Module plugged into the **Module 2 connector**.

Field Terminals, Normally Closed (**NCx**), Common (**COMx**), and Normally Open (**NOx**) connect to the field devices. **NCx** and **COMx** are used to provide a normally closed connection when the relay is not energized. **NOx** and **COMx** are used to provide a normally open connection when the relay is not energized. The field termination connector is removable for ease of wiring maintenance and is retained by friction.

The relay coil x connects to the I/O modules input via the channel fuse to the **Module 1** and **Module 2 connectors**. Redundant operation uses two modules with one each connected to the **Module 1** and **Module 2 connectors**. Redundant operation is achieved by connecting the diode output from each channel on different modules together. Non-redundant systems have one module connected to either the **Module 1** or **Module 2 connectors**.

17.4 Installation Requirements

See Section 2, *Installation*, before performing any installation and observe all warnings

A common interconnecting cable (6ES7922-3BD00-0AS0 and 6ES7922-3BJ00-0AS0), supporting 10 DO channels, interconnects the discrete output termination assembly to the 10-channel, 24 VDC Failsafe discrete output module (6ES7 326-2BF10-0AB0, E-Stand 3 or higher).

Note

To disconnect the interconnecting cable shield from ground at the MTA only, cut and remove the shield disconnect jumper, **item 5**, for the associated cable. See Figure 17–.

17.5 Maintenance

See Section 3, *Maintenance*, before performing any maintenance and observe all warnings

Under normal operation, the **A/B Power LED** and the **Module 1/2 Fuse LED** are on. If all are off, check the power supply to MTA. If the **A/B Power LED** is off, check the power supply to the MTA. If the **Module 1/2 Fuse LED** is off, check the channel fuse and replace as necessary.

Remove field power before removing or installing any device.



Warning

Electrical shock hazard

- An electrical shock hazard exists for Relay Output MTAs only when connected to loads with voltage > 30V rms and 42.4V peak or 60V dc
 - Remove power from all wires and terminals before working on equipment.
 - For AC voltages all channels must be the same phase. For voltages greater than 150 VDC, all channels must be of the same voltage.
-

17.6 Simplified diagram

Figure 17-1 12/24-Channel, 24 VDC F Discrete Input Marshallled Termination Assembly (6ES7650-1AM31-6XX0 or 6ES7650-1AM30-6XX0)

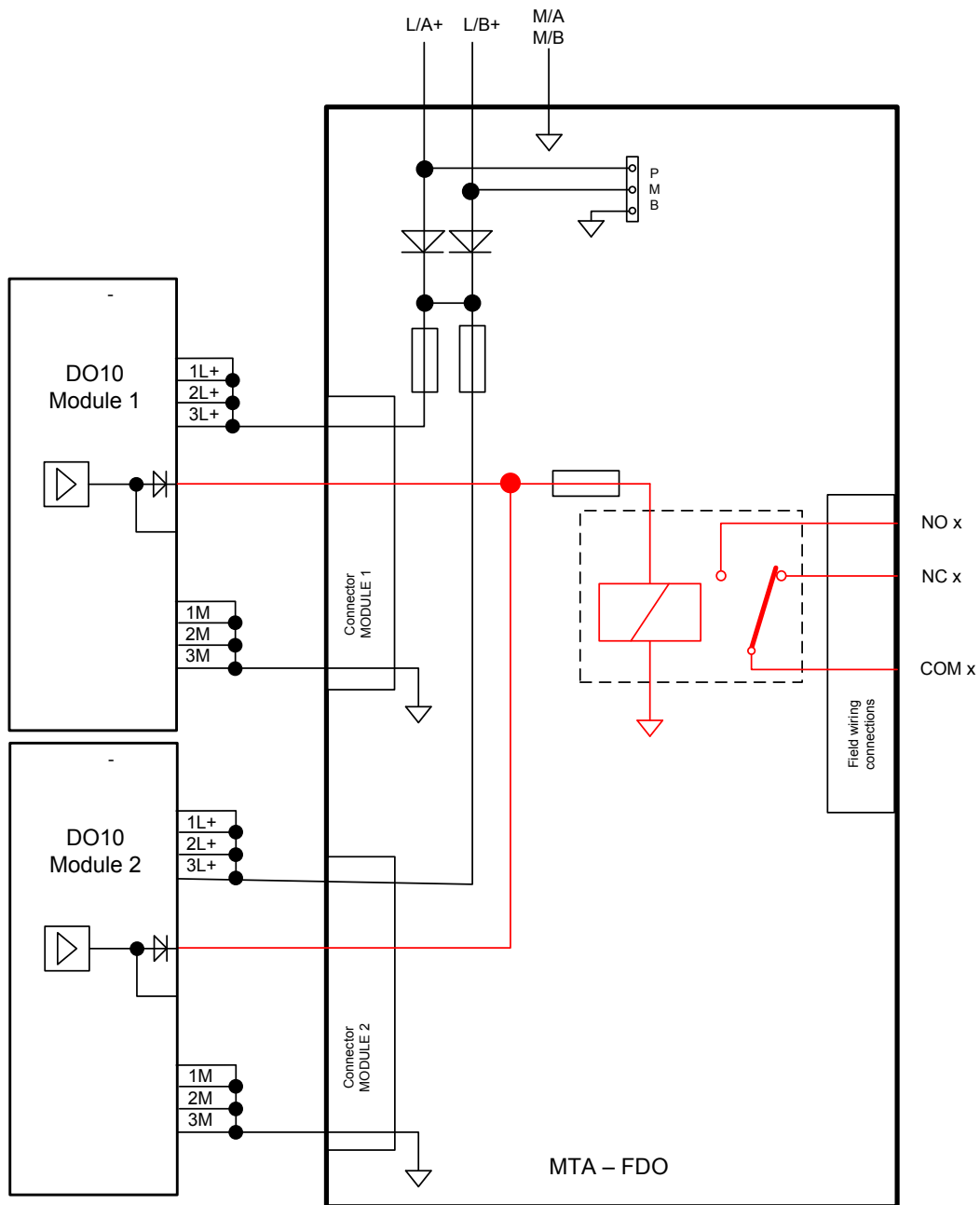

17.7 Failsafe 10-Channel, 24-150 VDC/120-230 VAC Relay Output Marshalled Termination Assembly

Figure 17– shows the basic parts of the 10-Channel, 24-150 VDC/120-230 VAC Relay Output MTA.

Figure 17–2 10-Channel, 24-150 VDC/120-230 VAC Relay Output Marshalled Termination Assembly (6ES7650-1AM30-6XX0 or 6ES7650-1AM31-6XX0)

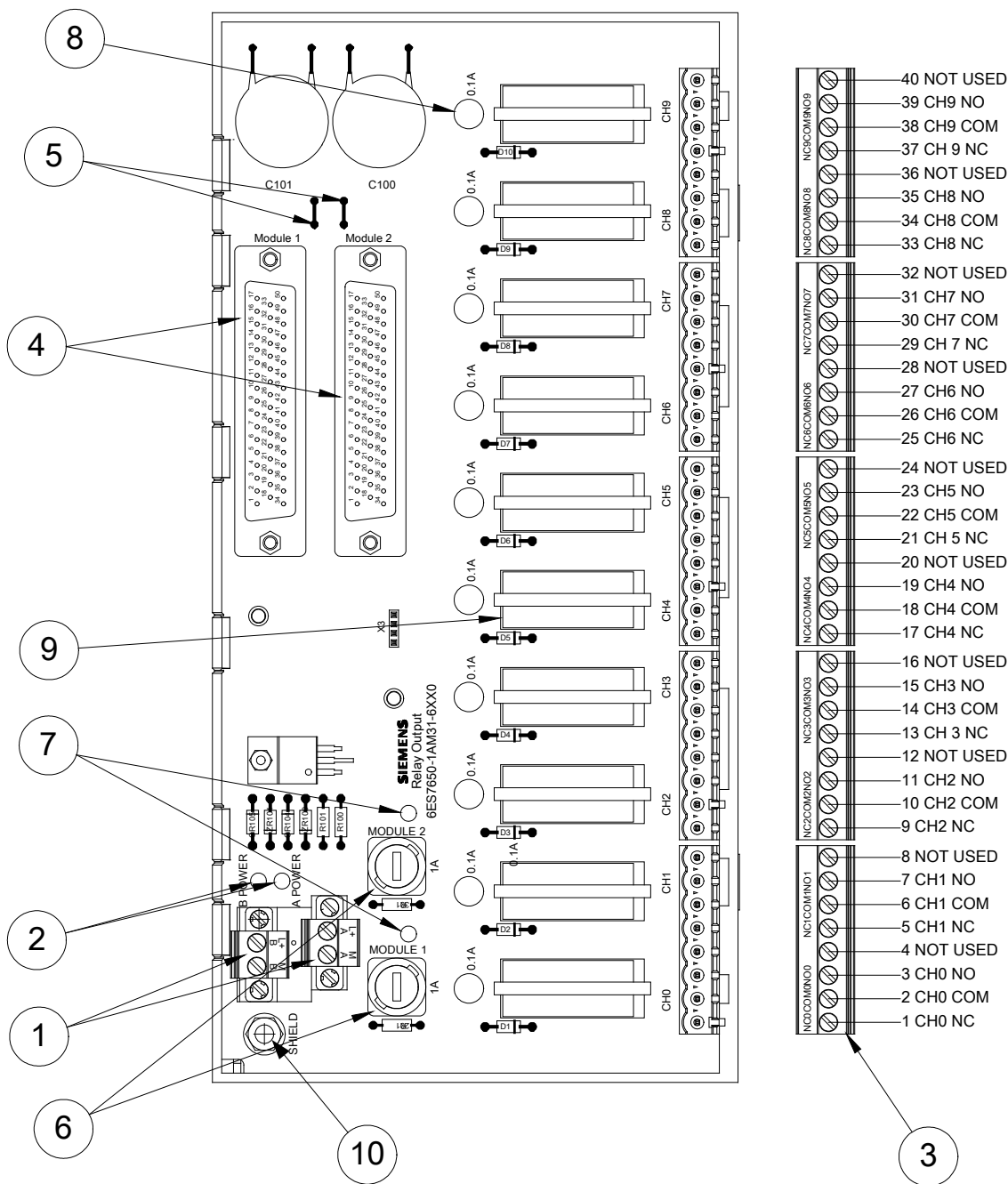

Key to numbered items in Figure 17-:	
Item	Description
1	Input power connections
2	Input power indicators
3	Field wiring connections
4	I/O module connectors
5	Shield disconnect jumpers
6	Module power fuses
7	Module power indicators
8	Module output fuse (1 of 10)
9	Relay (1 of 10)
10	Shield Ground Stud for connecting to earth ground

17.8 Technical Specifications

Note

Technical specifications differ slightly for the two MTA part numbers. Note the part number and refer to the appropriate sections below.

17.8.1 Technical Specifications for 6ES7650-1AM30-6XX0

Technical Specifications: 10-Channel, 24-150 VDC/120-230 VAC Relay Output MTA (6ES7650-1AM30-6XX0)	
Dimensions - See Section 1, Figure 1.3, Long Version	
L x W x D – inches	9.07 x 4.55 x 2.87
L x W x D – mm	230.4 x 130.9 x 73
Mounting	
DIN Rail	35mm (deep top hat style)
Power Input	
Voltage Input for Single or Redundant Feed	21.6 to 28.8 VDC
Current Consumption (nominal ratings; all channels connected)	
All outputs ON	0.820 A maximum
All outputs OFF	0.575 A normal
Power Dissipation (typical)	7 W
Terminal Block Wire Sizes	TB100 & TB101
Wire Size – US/ Metric	24 – 14 gauge AWG / 0,205 – 2,08 mm sq.
Power Supply Specifications	See Module Specs
Fuse Ratings	
Module Power	1.0 A (Bussmann P/N: GMA-1.0A) (Siemens Spare P/N: A5E01568881)
Individual channel – Normal	0.10 A (Littelfuse P/N 273.100) (Siemens Spare P/N: A5E01568889)
Indicators	
Input Power	Green LED on when input power available
Module Power	Green LED on when module power available
Channel Power	NA
Field Terminal Block Wire Sizes TB1 – TB5	
Wire Size – US	24 – 14 gauge AWG
Wire Size – Metric	0,205 – 2,08 mm sq.
Relay Contacts	
Output Contacts	Normally Open – NO Common – C Normally Closed – NC

Overvoltage Installation Category	
Category III	150V maximum
Category II	250V maximum
Environmental	
Ambient Temperature	-25C to +60C
Humidity	5% to 95% Non-condensing
Approvals	
MTA Agency Approvals	See Preface section, Approvals Table
Max achievable Safety Integrity Level in safety mode	
In Accordance with IEC 61508	SIL 2

Fail-safe performance Characteristics		
(unprotected inductive loads should not be used for failsafe functions)	Resistive and protected inductive AC loads	Resistive and protected inductive DC loads
Low demand mode (average probability of failure on demand) per channel.	PFDavg <= 1.26E-03; Up to 5 yr proof time PFDavg <= 2.5E-03; Up to 10 yr proof time PFDavg <= 5.0E-03; Up to 20 yr proof time	PFDavg <= 6.30E-03; Up to 5 yr proof time PFDavg <= 1.26E-02; Up to 10 yr proof time PFDavg <= 2.5E-02; Up to 20 yr proof time
High Demand continuous mode (probability of dangerous failure per hour per channel)	PFH <= 5.8E-08	PFH <=2.9E-07

17.8.2 Technical Specification for 6ES7650-1AM31-6XX0

Technical Specifications: 10-Channel, 24-150 VDC/120-230 VAC Relay Output MTA (6ES7650-1AM31-6XX0)	
Dimensions - See Section 1, Figure 1.3, Long Version	
Mounting	
DIN Rail	35mm (deep top hat style)
Power Input	
Voltage Input for Single or Redundant Feed	21.6 to 28.8 VDC
Current Consumption @ 24 VDC	
10 Channels Active	0.56 A Typical
5 Channels Active	0.42 A Typical
Terminal Block Wire Sizes	
Wire Size – US	24 – 14 gauge AWG
Wire Size – Metric	0,205 – 2,08 mm sq.
Power Supply Specifications	See Module Specs

Fuse Ratings	
Module Power	1.0 A (Bussmann P/N: GMA-1.0A) (Siemens Spare P/N: A5E01568882)
Individual channel – Normal	0.10 A (Littelfuse P/N 273.100) (Siemens Spare P/N: A5E01568889)
Indicators	
Input Power	Green LED on when input power available
Module Power	Green LED on when module power available
Channel Power	NA
Field Terminal Block Wire Sizes	
Wire Size – US	24 – 14 gauge AWG
Wire Size – Metric	0,205 – 2,08 mm sq.
Relay Contacts	
Output Contacts	Normally Open – NO Common – C Normally Closed – NC (Siemens Spare P/N A5E02164558)
Environmental	
Ambient Temperature	-25C to +70C (Horizontal Mounting) -25C to +40C (Vertical Mounting) -25C to +60C (Vertical Mounting, CH5 to CH9 only)
Humidity	5% to 95% Non-condensing
Approvals	
Maximum achievable safety class in safety mode	
SIL according to IEC 61508, DIN EN 62061	SIL 2
Performance Level according to EN ISO 13849-1	DC: PLb AC: PLc
Category according to EN ISO 13849-1	DC: Cat. B AC: Cat. 1
Failsafe performance characteristics	
Resistive and protected inductive loads (unprotected inductive loads should not be used for failsafe functions)	
Low Demand (PFD) according to SIL 2 (per channel)	< 2,53 E-2 (up to 10 yr proof time) < 5,06 E-2 (up to 20 yr proof time)
High Demand (PFH) according to SIL 2 (per channel)	< 5,77 E-7 1/h
Note: SIL2 requires that there is a signal change at least once a year and that the process status is read back. If a fault is detected during this function test, replace the Relay MTA module.	
Overvoltage Installation Category	
Category III	150V maximum
Category II	250V maximum

Isolation	
between channels < -- > shield + secondary	Yes (250 VAC)
between the channels	Yes. $U < = 150$ V reinforced insulation $U > 150$ V to 250 V basic insulation
Insulation test	Test voltage (routine test at IEC 61131-2)
Rated voltage $150\text{V} < U_e \leq 300\text{V}$	1350 VAC/2sec (all channels to sec. + shield)
Rated voltage $100\text{V} < U_e \leq 150\text{V}$	820 VAC/2sec (between channels for 150 VDC)

Note

Fuses are available as spare parts from Siemens.

Fuse information can be found at:

<http://www.littelfuse.com>

<http://www.bussmann.com>

Relays are available as spare parts from Siemens.

Relay Information can be found at:

<http://www.azettler.com>

17.9 Module Restrictions

Note

Module restrictions differ slightly for the two MTA part numbers. Note the part number and refer to the appropriate sections below.

17.9.1 Module Restrictions for 6ES7650-1AM30-6XX0

Restrictions for 10-Channel, 24-150 VDC/120-230 VAC Relay Output MTA (6ES7650-1AM30-6XX0)	
I/O Module Restrictions	
Module Design - Diode Outputs used	See module specifications for limitations
Relay	
Maximum Relay Contact Ratings	Resistive Load: Max Switched Power: 150 W Or 1250 VA Max Switched Current: 5 Amps at 120 VAC – 230 VAC 5 Amps at 24 VDC 0.4 A at 120 VDC ¼ HP @ 120 VAC motor load
Coil Resistance	1200 Ohm (Nominal)
Minimum Output Rating (Wetting Rating)	0.1 A at 5 VDC
Relay Output Fuse	None - External Fusing required
Minimum operations	
Mechanical	30 million operations
Electrical	1 x 10 ⁵ at 10 A, 24 VDC or 120 VAC 2 x 10 ⁵ at 8 A, 230 VAC
Relay Contact Restrictions	
Relay Output Fusing	Fuses for the relay output connection must be provided externally to the MTA
Relay Voltage Restrictions	For voltages up to 150 VDC channels may be mixed mode. For voltages greater than 150 VDC, all channels must be of the same voltage. For AC voltages all channels must be the same phase.

17.9.2 Module Restrictions for 6ES7650-1AM31-6XX0

Restrictions for 10-Channel, 24-150 VDC/120-230 VAC Relay Output MTA (6ES7650-1AM31-6XX0)	
I/O Module Restrictions	
Module Design - Diode Outputs used	See module specifications for limitations
Relay	
Maximum Relay Contact Ratings	Resistive Load: Max Switched Power: 120 W or 1150 VA Max Switched Current: 5 Amps at 120 VAC – 230 VAC 5 amps at 24 VDC 0.4 A at 120 VDC ¼ HP @ 120 VAC motor load UL Contact Ratings: 0.7A / 24 VDC resistive 5A / 277 VAC resistive R300 B300
Coil Resistance	810 Ohm (Nominal)
Minimum Output Rating (Wetting Rating)	0.1 A at 5 VDC
Relay Output Fuse	None - External Fusing required
Minimum operations	
Mechanical	10 million operations
Electrical	1 x 105 at 5 A, 230 VAC Resistive Load
Relay Contact Restrictions	
Relay Output Fusing	Fuses for the relay output connection must be provided externally to the MTA
Relay Voltage Restrictions	For voltages up to 150 VDC channels may be mixed mode. For voltages greater than 150 VDC, all channels must be of the same voltage. For AC voltages all channels must be the same phase.

17.10 Typical Load Connection to Field Terminals

Figure 17-3 10-Channel, 24-150 VDC/120-230 VAC Relay Output MTA Load Connection to Field Terminals

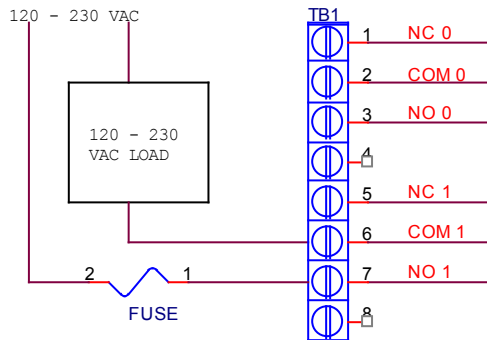

LOAD POWERED WHEN OUTPUT ENERGIZED

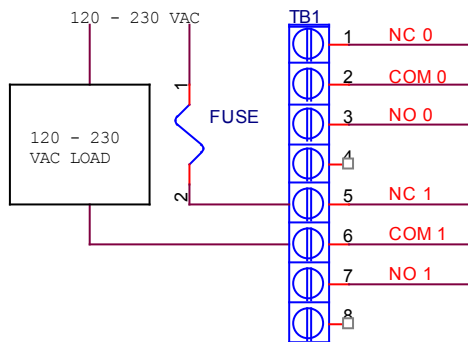

LOAD POWERED WHEN OUTPUT DE-ENERGIZED

Note

- Fuse is external to the MTA and not included.
- Fuse should be sized appropriately for the load.
- Only the NO connection shall be used in safety related applications.

17.11 Hardware Configuration

The 10 channel Fail-Safe Discrete Output Module and its Relay Output MTA support Redundant and Non-redundant operation.

17.11.1 Addresses

Non-redundant Operation

The choice of the Input Address and Process Image are left to the user.

Redundant Operation

Process Image should be set to something other than the default. The choice of the Input Address is left to the user.

Figure 17– shows a redundant configuration.

Figure 17–4 10-Channel Fail-Safe Discrete Output Hardware Configuration: Addresses set for Redundant Operation

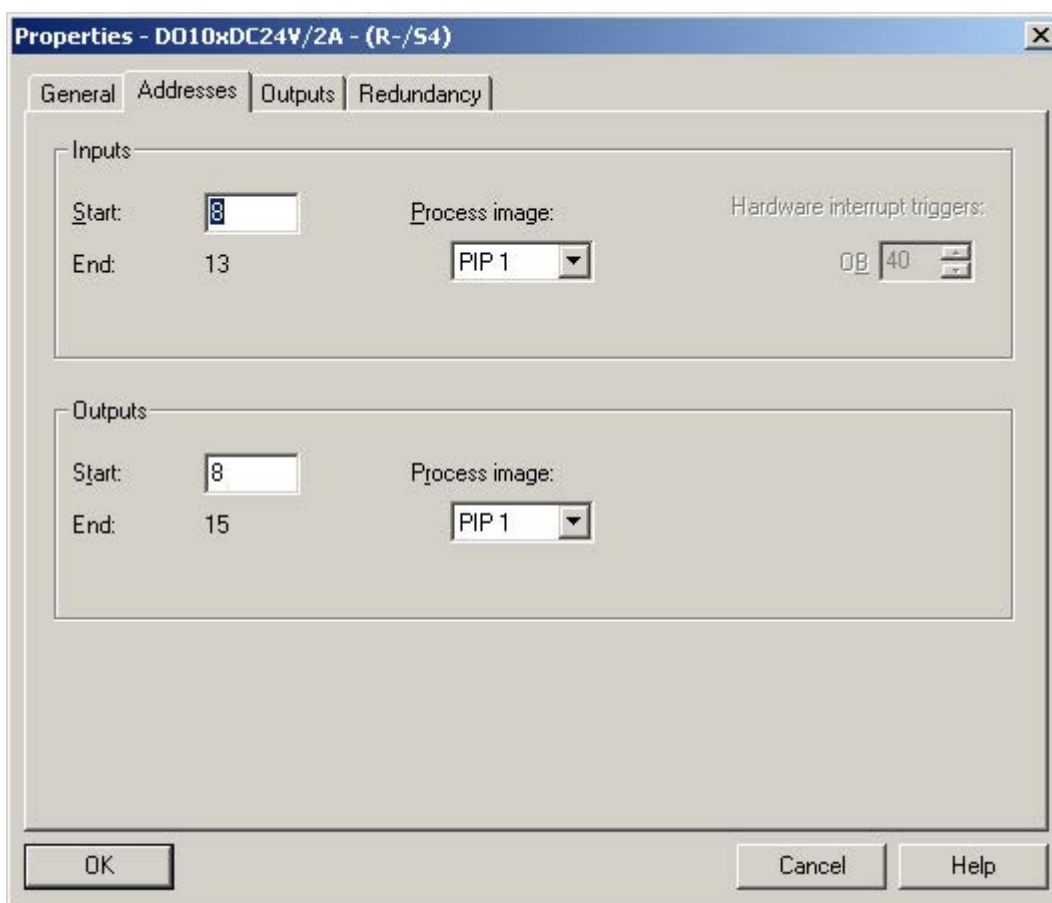

17.11.2 Outputs

The Relay Output MTA uses the series diode outputs from the FDO module for both redundant and non-redundant operation. This determines which diagnostics are generated. More information about these effects can be found in the I/O Restrictions section of the **Technical Specifications** table and the module specifications.

All options should be set to user preferences.

Figure 17– shows the FDO configured for **Standard Mode** and all the diagnostics enabled.

Figure 17–5 10-Channel Fail-Safe Discrete Output Hardware Configuration: Outputs Configured for Standard Mode

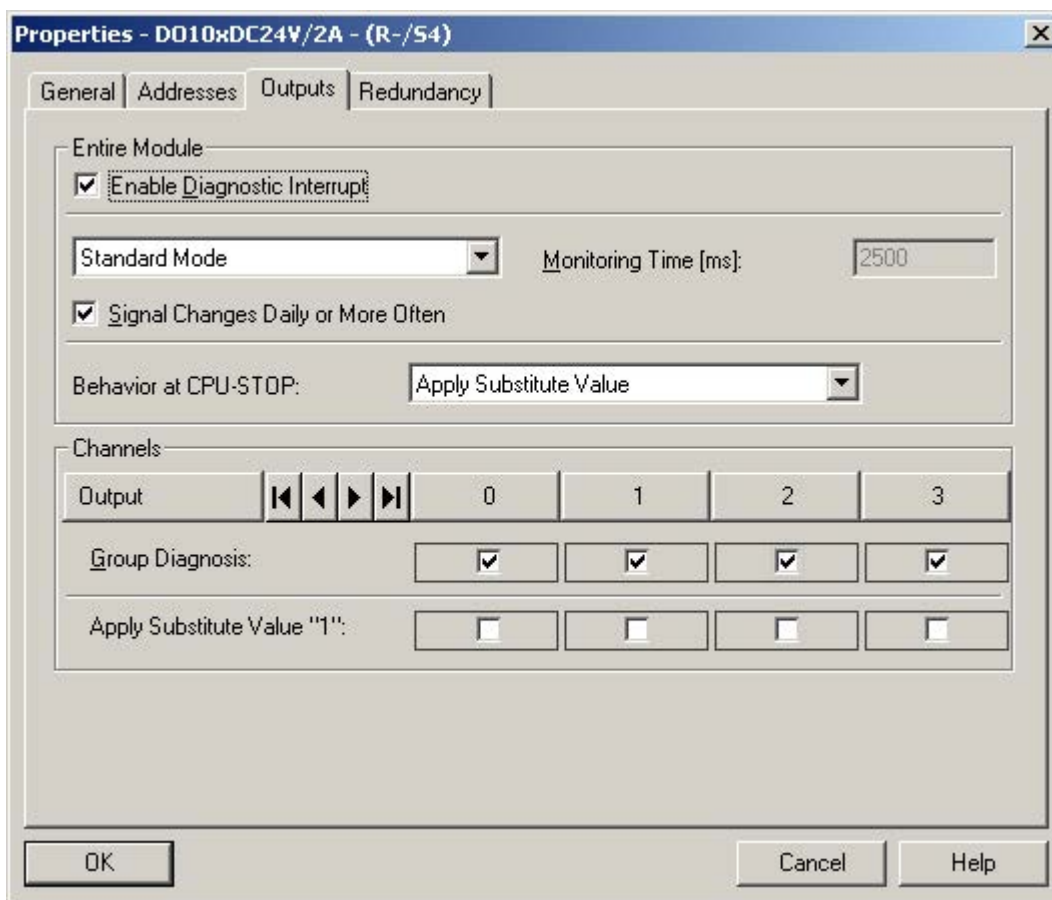

17.11.3 Redundancy

Figure 17– shows a redundant FDO configuration.

Figure 17–6 10-Channel Fail-Safe Discrete Output Hardware Configuration: Redundancy Selections

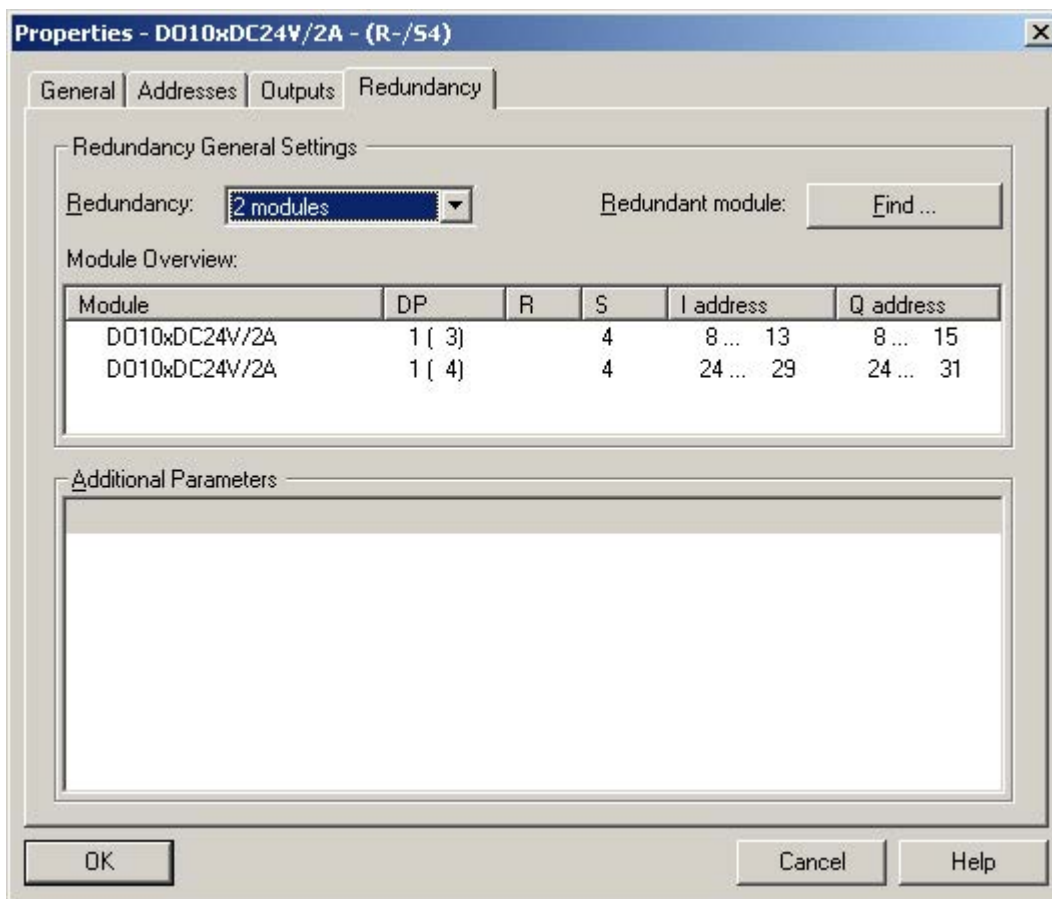

17.12 Technical Specifications for 10-Channel, 24 VDC F Discrete Output Module (6ES7 326-2BF10-0AB0)

Note

For a complete functional description and the most current technical specifications for this module, refer to the manual *S7-300 Automation System Fail-Safe Signal Modules* (document number A5E00085586).

18 16-Channel, 24-150 VDC/120-230 VAC Relay Output MTA

Part No. 6ES7650-1AM30-3XX0

18.1 Description

This section contains information and requirements to facilitate installation of Siemens, 24-150 VDC/120-230 VAC Relay Output Marshalled Termination Assembly (MTA) (6ES7650-1AM30-3XX0), designed to interface with the Siemens ET 200M 16-Channel Discrete Output Module (6ES7 322-8BH01-0AB0, E-Stand 1 or higher).

18.2 Features

The following features have been incorporated into this MTA:

- Form C Relay for each output
- Redundant power connections
- LED indication of redundant power supply condition
- Power monitor plug-in available (optional)
- Dual connectors for redundant I/O Module operation
- Per module power fusing
- Per channel LED indication of output status (ON or OFF)
- Ground stud for connecting shield to earth ground
- Power input and field terminations are pluggable for easy maintenance

18.3 Operation

Power is supplied via the removable power connector marked **L+A**, **MA**, and **L+B**, **MB**. Each has a LED to indicate the presence of voltage over 15 VDC. The LEDs are marked **A POWER** and **B POWER**. There is also a connector for a Power Monitor board used to indicate the presence of both A and B power. See Section 13 Power Monitor Board, (6ES7650-1BA02-0XX0).

Incoming power from **A** and **B** is diode OR'd to provide the MTA and the module power from either power source. The output from the dual diode is sent to the I/O modules via the module power fuses.

Field Terminals, Normally Closed (**NCx**), Common (**COMx**), and Normally Open (**NOx**) connect to the field devices. **NCx** and **COMx** are used to provide a normally closed connection when the relay is not energized. **NOx** and **COMx** are used to provide a normally open connection when the relay is not energized. The field termination connector is removable for ease of wiring.

The relay coil x connects to the I/O module. Redundant operation uses two I/O modules. Redundant operation is achieved by connecting the diode output from each channel on different I/O modules together. Non-redundant systems have one I/O module connected.

18.4 Installation Requirements

See Section 2, *Installation*, before performing any installation and observe all warnings

A common interconnecting cable (6ES7922-3BD00-0AS0 and 6ES7922-3BJ00-0AS0), supporting 16 DO channels, interconnects the relay output termination assembly to the 16-channel, 24 VDC Failsafe discrete output module (6ES7 322-8BH01-0AB0, E-Stand 1 or higher).

Note

To disconnect the interconnecting cable shield from ground at the MTA only, cut and remove the shield disconnect jumper for the associated cable. See figure 15.1.

18.5 Maintenance

See Section 3, *Maintenance*, before performing any maintenance and observe all warnings

Under normal operation, the **A/B Power LEDs** and the **Module 1/2 Fuse LEDs** are on. If all are off, check the power supply to MTA. If the **A/B Power LEDs** are off, check the power supply to the MTA. If the **Module 1/2 Fuse LEDs** are off, check the channel fuse and replace as necessary.

The relays are socketed to allow replacement in the field. A relay may be replaced in non hazardous locations with power applied to the MTA (see warning below). Only the channel associated with that relay will be affected. Some relay positions have near-by components that prevent finger access. The use of long-nose pliers will be needed for those locations. See figure 15-1.

Replacement of a relay can be facilitated by removing the cable connectors and frame. Reference figure 1-2 for information on the frame. It may also be helpful to unplug the field connector adjacent to the relay that you are replacing.

Note

Multiple simultaneous channel short circuits or overloads may cause the module power fuse (on the MTA) to open. Repair the channels short circuits and overloads as soon as possible.



Warning**Electrical shock hazard**

- An electrical shock hazard exists for Relay Output MTAs only when connected to loads with voltage > 30V rms and 42.4V peak or 60V dc
 - Remove power from all wires and terminals before working on equipment.
 - For voltages greater than 150 VDC, all channels must be of the same voltage. For AC voltages all channels must be the same phase for the channels in one group. There can be different phases between groups.
-

18.6 Component Identification

Figure 18-1 16-Channel, 24-150 VDC/120-230 VAC Relay Output Marshalled Termination Assembly (6ES7650-1AM30-3XX0). Shown without cover and frame. Reference figure 1-2 for cover and frame information.

TO REMOVE RELAY PUSH PLASTIC CLIP TO THE SIDE AND USE NEEDLE NOSE PLIERS TO GRIP RELAY AND REMOVE

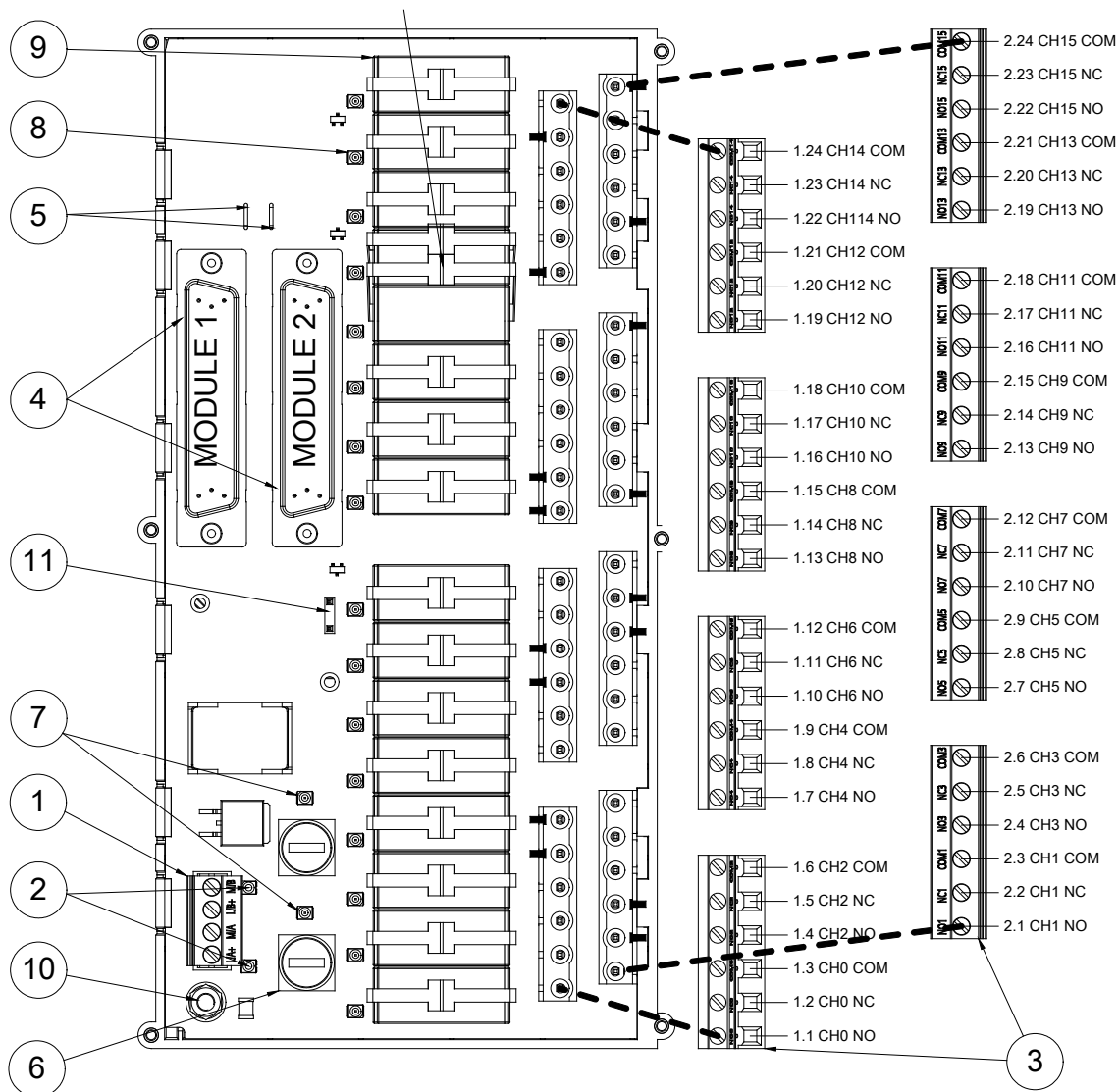

Key to numbered items in Figure 18–1:	
Item	Description
1	Input power connections (Power A, Power B)
2	Input power indicators (Power A, Power B)
3	Field wiring connections
4	I/O module connectors (Module 1, Module 2)
5	Shield disconnect jumpers (Module 1, Module 2)
6	Module power fuses (Module 1, Module 2)
7	Module power indicators (Module 1, Module 2)
8	Channel status indicators (1 of 16)
9	Relay (1 of 16)
10	Ground stud for connecting shield to earth ground
11	Power Monitor Board (Optional) Connector

18.7 Technical Specifications

Technical Specifications: 16-Channel, 24-150 VDC/120-230 VAC Relay Output MTA (6ES7650-1AM30-3XX0)	
Dimensions - See Section 1, Figure 1.3, Long Version	
Mounting	
DIN Rail	35mm (deep top hat style)
Orientation	horizontal or vertical
Power Input	
Voltage Input for Single or Redundant Feed	21.6 to 28.8 VDC
Current Consumption (nominal ratings)	
All Channels Active	0.71 A Typical
Power Dissipation (typical)	9 W
Wire Size – US / Metric	24 to 14 AWG / 0,205 – 2,08 mm sq.
Fuse Ratings	
Module	2.0 A (Bussmann P/N: GMA-3.0A) (Siemens Spare P/N: A5E01574387)
Environmental	
Ambient Temperature	-25C to +60C
Humidity	5% to 95% Non-condensing
Approvals	
MTA Agency Approvals	See Preface section, Approvals Table
Indicators	
Input Power	Green LED on when input power available, Red LED on when power polarity is reversed
Module Power	Green LED on when module power available
Channel Status	Green LED on when channel is ON
Field Connections	
Output Contacts	Normally Open – NO Common – C Normally Closed – NC
Wire Size – US / metric	24 to 14 AWG
Wire Size – Metric	0,205 – 2,08 mm sq.*
Isolation	
between channels < -- > shield + secondary	Yes (250 VAC)
between the channels	yes. U <= 150V reinforced insulation U > 150V to 250V basic insulation
permissible voltage between groups of 8 channels	500 VAC (basic insulation)

Technical Specifications: 16-Channel, 24-150 VDC/120-230 VAC Relay Output MTA (6ES7650-1AM30-3XX0)	
Insulation test	Test voltage (routine test at IEC 61131-2)
Rated voltage 150V < Ue ≤ 300V	1350 VAC/2sec (all channels to sec.+ shield)
Rated voltage 100V < Ue ≤ 150V (reinforced)	820 VAC/2sec (between channels for 150 VDC)
Rated voltage 300V < Ue ≤ 600V	2200 VAC/2sec (Group 0 <--> Group 1)
Relay	
Maximum Relay Contact Ratings	Resistive Load: Max Switched Current: 5 Amps at 120 VAC – 230VAC 5 amps at 24 VDC 0.4 A at 150 VDC UL Contact Ratings: 5A/250 VAC General Purpose (Siemens Spare P/N A5E02164559)
Switching Frequency	Resistive load max. 0.1Hz
Coil Resistance	1440 Ohms (Nominal)
Minimum Output Rating (Wetting Rating)	100 mA at 12 VDC
Relay Output Fuse	None - External Fusing required
Minimum operations	
Mechanical	30 million operations
Electrical	2 x 10 ⁵ at 10 A, 250 VAC, cosφ=0.6, 70°C
Relay Contact Restrictions	
Relay Contact Fusing	Fuses for the relay output connection must be provided externally to the MTA
Relay Contact Protection	To extend the life of the relay contacts protection components should be used. The protection components depend on the load voltage (ac or dc) and the load characteristics (high current, inductive, etc.)
Relay Voltage Restrictions	For voltages up to 150 VDC channels may be different voltages (one channel SELV and next max. 150 VDC). For voltages greater than 150 VDC, all channels must be of the same voltage. For AC voltages all channels must be the same phase for the channels in one group. There can be different phases between groups.

* Limiting the signal wiring to 14 AWG / 2.1 mm² will make it easier to assemble and remove the MTA cover.

Note Fuses are available as spare parts from Siemens.
 Fuse information can be found at:
<http://www.bussmann.com>

Relays are available as spare parts from Siemens.
 Relay Information can be found at:
<http://www.azettler.com>

18.8 Changes to 16-Channel, 24 VDC Discrete Output Module (6ES7 322-8BH01-0AB0) Specifications

This section contains changes to the I/O module specifications when it is used with the MTA.

Changes to 16-Channel, 24 VDC Discrete Output Module(6ES7 322-8BH01-0AB0) Specifications when used with 16-Channel, 24-150 VDC/120-230 VAC Relay Output MTA (6ES7650-1AM30-3XX0)	
Reverse polarity power supply protection	Yes
Only outputs with series diodes are used.	Therefore the behavior of the 6ES7322-8BH01 is according Manual for 6ES7322-8BH01 chapter 6.3.2 Tips and .../ Lamps / par 2) : -Diagnostic Message "M-short current" disabled in case of signal "0" - Diagnostic Message "P-short current" is changed to "broken wire"

18.9 Technical Specifications for 16-Channel, 24 VDC Discrete Output Module (6ES7 322-8BH01-0AB0)

Note For a complete functional description and the most current technical specifications for this module, refer to the manual SIMATIC ET 200M Signal Modules for Process Automation (document number A5E00085262-04).

18.10 Typical Load Connection to Field Terminals

Figure 18–2 16-Channel, 24-150 VDC/120-230 VAC Relay Output MTA Load Connection to Field Terminals

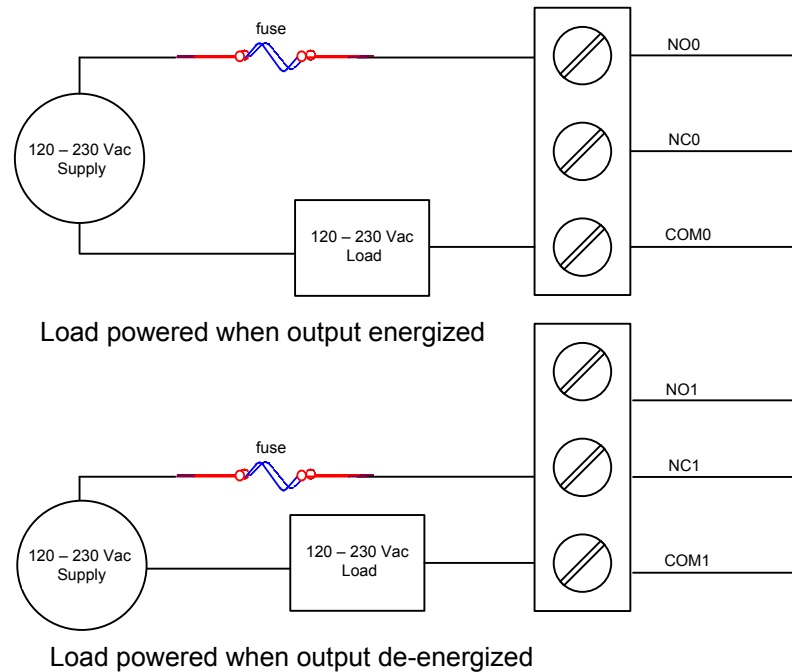

- Note**
- Fuse is external to the MTA and not included.
 - Fuse should be sized appropriately for the load.

18.11 Hardware Configuration

The 16-Channel Discrete Output Module and its MTA support redundant and non-redundant operation.

18.11.1 Addresses

Non-redundant Operation

The choice of the Input Address and Process Image are left to the user.

Redundant Operation

Process Image should be set to something other than the default. The choice of the Input Address is left to the user.

Figure 18–3 shows a redundant configuration.

Figure 18–3 16-Channel Discrete Output Hardware Configuration: Addresses set for Redundant Operation

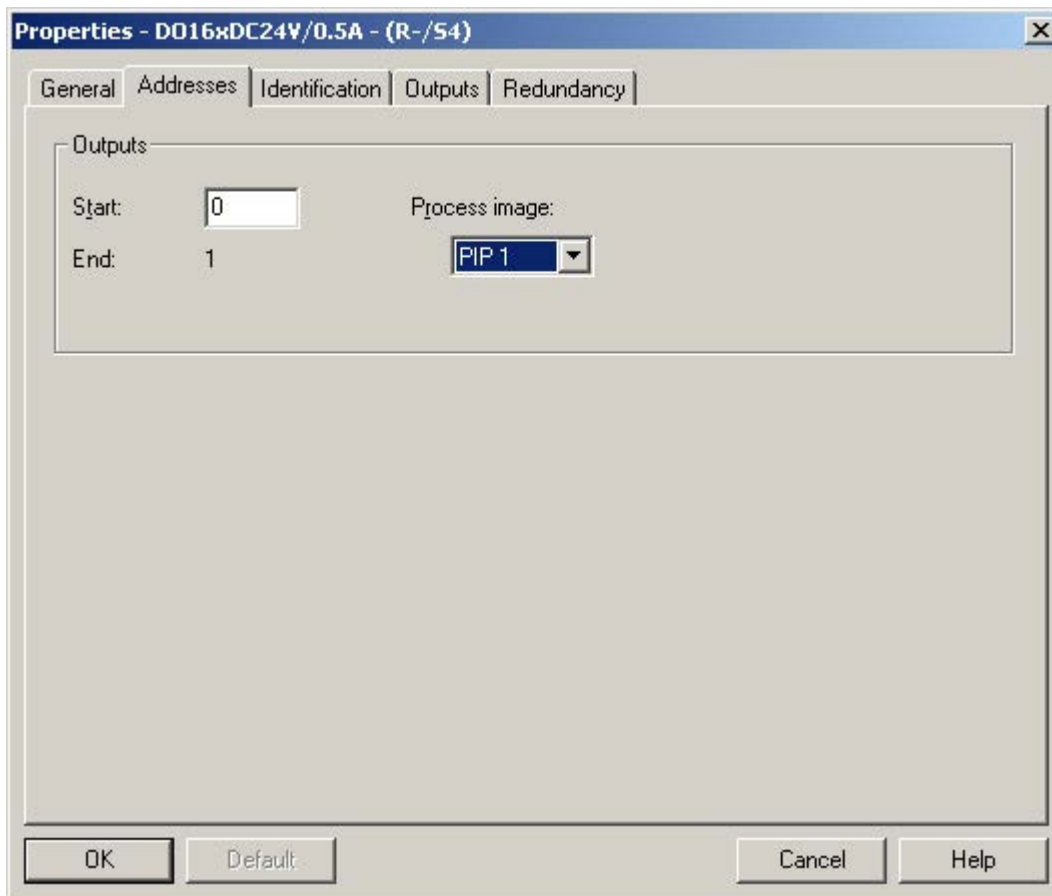

18.11.2 Outputs

The Relay Output MTA uses the series diode outputs from the DO16 module for both redundant and non-redundant operation.

All options should be set to user preferences.

Figure 18–4 shows the DO16 configured with all the diagnostics enabled.

Figure 18–4 16-Channel Discrete Output Hardware Configuration: Outputs Configured for Standard Mode

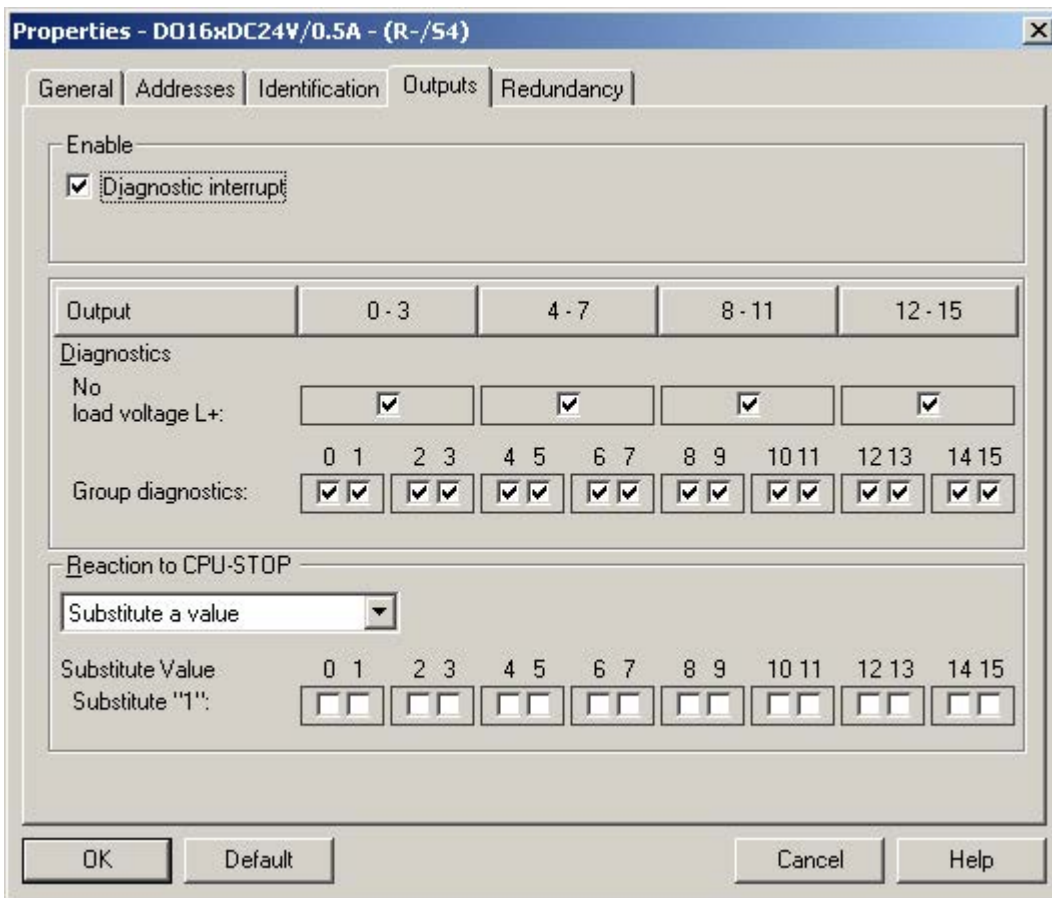

18.11.3 Redundancy

Figure 18–5 shows a redundant 16-Channel Discrete Output configuration.

Figure 18–5 16-Channel Discrete Output Hardware Configuration: Redundancy Selections

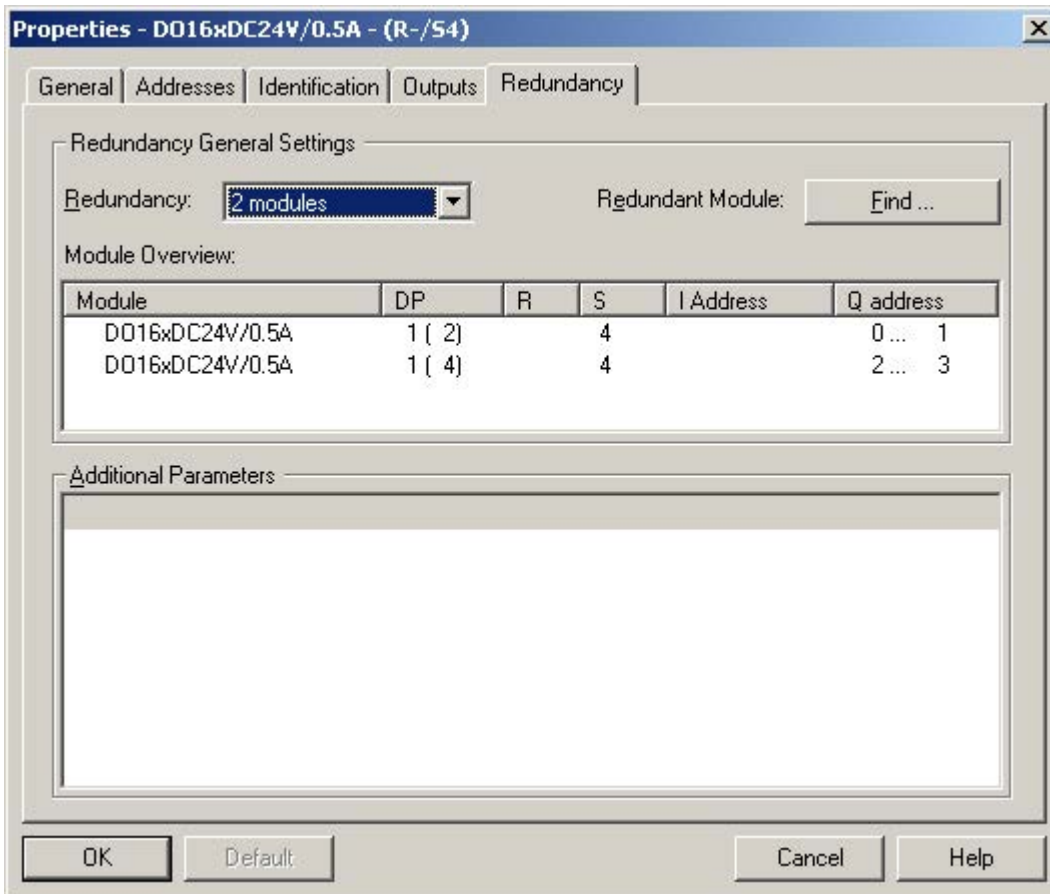

19 Power Monitor Board

Part No. 6ES7650-1BA02-0XX0

19.1 Description

This section contains information and requirements to facilitate installation of Siemens Power Monitor Board (6ES7650-1BA02-0XX0), designed to interface with the Siemens ET 200M MTAs.



Caution

A previous version of the Power Monitor Board (6ES7650-1BA00) exists. The previous version is not suitable for use on MTAs with covers.

19.2 Features

The following features have been incorporated into this board:

- Dry contact output
- Plug-in option

19.3 Operation

The Power Monitor Board (PMB) is used to provide an isolated dry contact for use when redundant power is supplied to the MTAs. If power is supplied to both power inputs and the power monitor board is installed, then the output contacts are closed and can be used to indicate this status. The PMB is designed to detect only the presence or absence of power. The PMB is not designed to detect supply voltage that is outside the specification threshold.

The PMB is an optional accessory that plugs into the MTA and is secured via standoffs and screws. It contains 2 relays that are connected to the MTA power inputs. Power input **A** energizes one relay and Power input **B** energizes the second relay. The relay contacts are wired in series so that both power inputs must be valid before a complete contact closure is made. If one power supply is not functioning, then one relay de-energizes and one set of contacts open, breaking the circuit back to the sense system.

Field Terminals, 1 and 2, are the output contacts for the external sensing system.

See Section 2, *Installation*, before performing any installation and observe all warnings

See Section 3, *Maintenance*, before performing any maintenance and observe all warnings

19.4 Power Monitor Board

Figure 19-1 Power Monitor Board

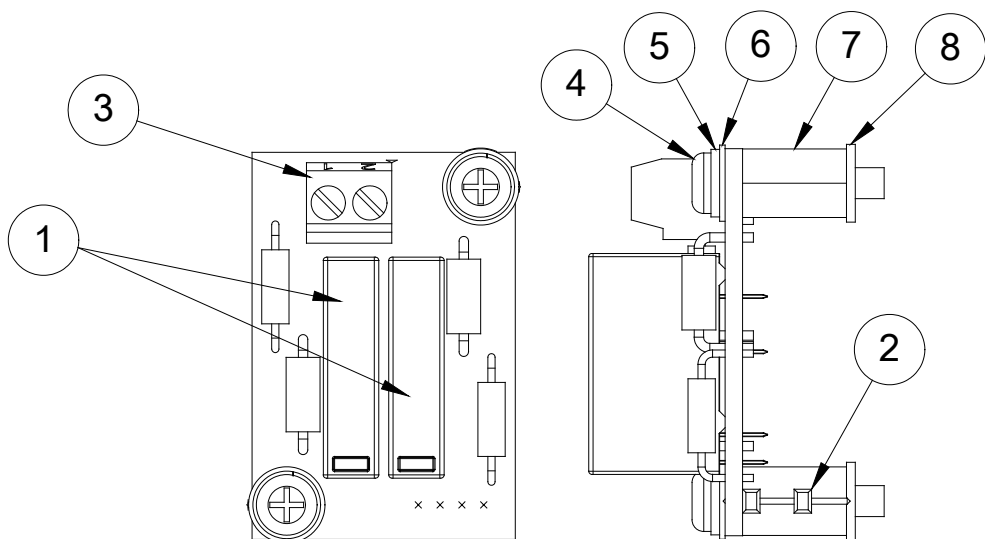

Key to numbered items in Figure 19-1:	
Item	Description
1	Relays
2	Input Connector
3	Field Terminals 1 & 2 (Output Contacts)
4	Mounting Screw
5	Lock Washer
6	Flat Washer
7	Standoff
8	Retaining Washer

19.5 Technical Specifications

Technical Specifications for Power Monitor Board (6ES7650-1BA02-0XX0)	
Dimensions	
L x W x D – inches	1.40 x .95 x 1.0
L x W x D – mm	35.6 x 24.1 x 25.4
Relay Output Contact Ratings	
Maximum Switched Voltage	30 VDC
Maximum Switched Current	0.5 A
Terminal Block Wire Size	
Wire Size – US	26 – 16 gauge AWG
Wire Size – Metric	0,128 – 1,31 mm sq.
Power Input	
Voltage Input for Single or Redundant Feed	21.6 to 28.8 VDC
Current Consumption - All outputs ON	0.040 A maximum
Relay Operations	
Electrical	100,000 minimum
Mechanical	20,000,000 minimum

20 8-Channel HART Analog Input MTA

Part No. 6ES7650-1AA61-2XX0

20.1 Description

This section contains installation information and requirements for Siemens Marshalled Termination Assembly (MTA) (6ES7650-1AA61-2XX0), which connects to the Siemens ET 200M 8-Channel HART Analog Input Module (6ES7 331-7TF01-0AB0).

20.2 Features

This MTA has the following features:

- Redundant power connections
- LED indication of redundant power supply condition
- Power monitor plug-in available (optional)
- Dual connectors for redundant I/O Module operation
- Per module power fusing
- Shield connections available for channel cabling
- Ground stud for connecting shield to earth ground
- Power input and field terminations are pluggable for easy maintenance
- Connectivity for HART Handheld Terminal (HHT) per channel
- Capable of mixing 2 and 4 wire transducers on a per channel basis
- The 2 wire transducer power supply is current limited. (No fuse to replace after a short in the field)

20.3 Operation

Power is supplied via a removable power connector marked **L+A**, **MA**, **L+B**, and **MB**. There is circuitry to detect the presence of voltage over 15 VDC and turn on the LED indicator. The LEDs are marked **A POWER** and **B POWER**. There is also a connector for a Power Monitor board used to indicate the presence of both A and B power. See section 16 Power Monitor Board (6ES7650-1BA02-0XX0).

Incoming power from **A** and **B** is diode OR'd to provide the MTA and the module power from either input source. The output from the ORing diode is sent to the I/O modules via the module fuses.

Field Terminals, Channel + (**Ix+**), Channel – (**Ix-**), Sensor power (**PWRx**) and Shield (**SHx**), connect to the field devices. **PWRx** is the +24 VDC power source and is current limited to about 40- 60 mA on a channel-by-channel basis. The field termination connector is removable for ease of wiring maintenance and is retained by friction.

The channel inputs from the MTA connect to the I/O modules inputs via D25 connectors (item 4 in figure 17.1). Redundant operation uses two modules, while non-redundant systems have one module connected to either I/O module connector.

20.4 Installation Requirements

See Section 2 Installation, before performing any installation and observe all warnings

A common interconnecting cable (6ES7922-3BD01-0AM0 or 6ES7922-3BJ01-0AM0), supporting eight analog input channels, connects the analog input termination assembly to the 8-channel analog input module (6ES7 331-7TF01-0AB0).

Note

To disconnect the interconnecting cable shield from ground at the MTA only, cut and remove the shield disconnect jumpers, **Module 1** and **Module 2**, for the associated cable.

20.5 Maintenance

See Section 3 Maintenance, before performing any maintenance and observe all warnings.

Under normal operation, the **A/B Power LEDs** and **Module 1/2 Fuse LEDs** are green. If all are off, check the power supply to MTA. If **Module 1/2 Fuse LED** is off, check the module fuse and replace if necessary

20.6 8-Channel HART Analog Input Marshalled Termination Assembly

The figure below shows the basic parts of the 8-Channel HART Analog Input MTA.

Figure 20–1 8-Channel HART Analog Input Marshalled Termination Assembly (6ES7650-1AA61-2XX0)

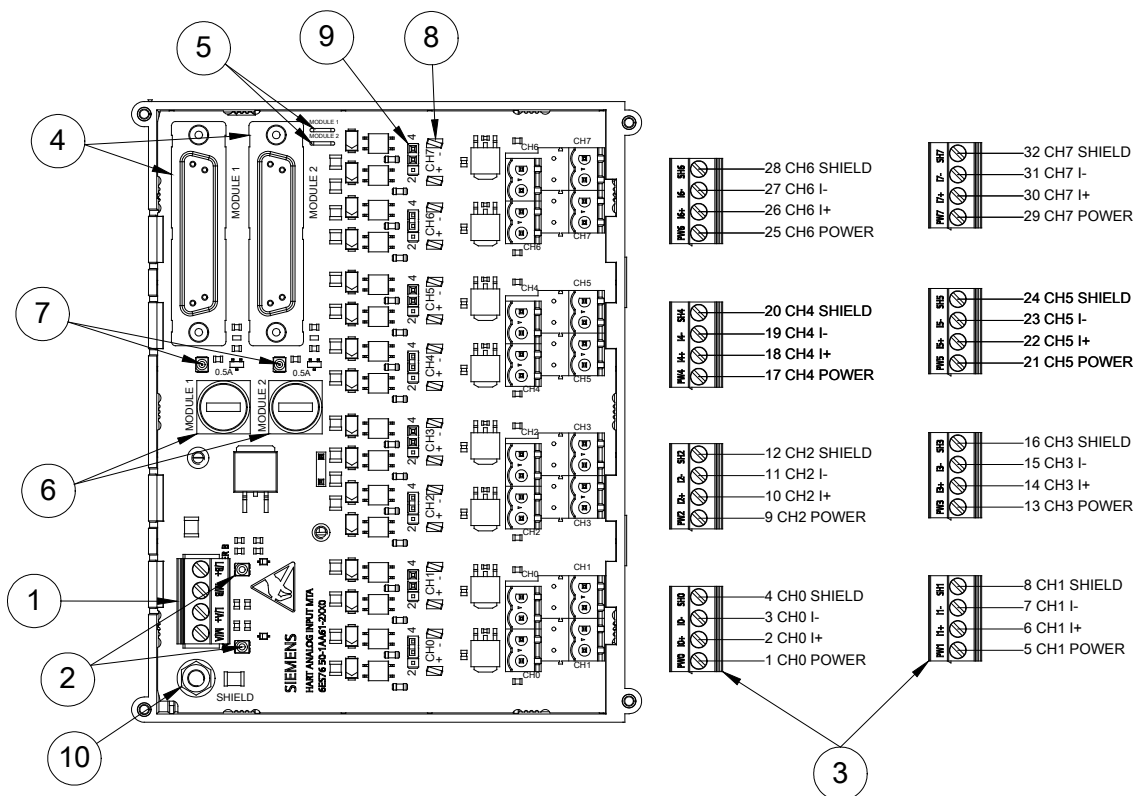

Key to numbered items in Figure 20–1	
Item	Description
1	Input power connections
2	Input Power Indicators
3	Field Connections
4	I/O Module Connections
5	Shield disconnect jumpers
6	Module power fuses
7	Module power indication
8	HART Handheld connectivity
9	Input Mode Jumper (2 or 4 wire transducers)
10	Shield Ground Stud for connecting to earth ground

20.7 Technical Specifications

Technical Specifications for 8-Channel HART Analog Input MTA (6ES7650-1AA61-2XX0)	
Dimensions - See Section 1, Figure 1.3, Short Version	
Mounting	
DIN Rail	35mm (deep or shallow; with panel mounted DIN rail only deep)
Power Input	
Voltage Input for Single or Redundant Feed	21.6 to 28.8 VDC
Current Consumption (nominal ratings; all inputs 2-wire transducers at 20mA, redundant modules)	0.29 A maximum
Power Dissipation (typical)	1 W
Terminal Block Wire Sizes	
Wire Size – US	24 – 14 AWG
Wire Size – Metric	0,205 – 2,08 mm sq.
Electrical Isolation	
Between the channels and shield	Yes
Between the channels	No
Between the channels and load voltage L+	For 2-wire transducer: No 4-wire transducer: Yes
Between the shield and load voltage L+	Yes
Permissible potential difference	
Between the channels and shield (U_{ISO})	75 VDC 60 VAC
Between the channels and load voltage L+	For 4-wire transducer: 75 VDC 60 VAC
Between the channels	Permissible common-mode voltage with a 4-wire transducer: 60 VAC
Between the shield and load voltage L+	75 VDC 60 VAC
Insulation tested	
Channels to shield and load voltage L+	With 500 VDC, MTA jumper must be in 4 wire position
Shield to load voltage L+	With 500 VDC
Between the channels	No
Fuse Ratings / Current Limiting	
Module	0.5 A (Bussmann P/N: GMA-0.5A) (Siemens Spare P/N: A5E01568885)
Channel (2 wire transducer connection)	short circuit current about 40 - 60 mA
Characteristic Data of Transducer Supply	
Output voltage for transducer and field wiring at 22 mA (125 Ω sense resistor on modules already taken into account)	≥ 15 V (at $U_n = 24$ V)

Technical Specifications for 8-Channel HART Analog Input MTA (6ES7650-1AA61-2XX0)	
Indicators	
Input Power	Green LED on when input power available, red LED on if power supply is reversed
Module Fuse OK	Green LED on when module power available
Field Terminals	
Wire Size – US	24 – 14 AWG
Wire Size – Metric	0,205 – 2,08 mm sq.
Environmental	
Ambient Temperature	-25C to +60C
Humidity	5% to 95% Non-condensing
Approvals	
MTA Agency Approvals	See Preface section, Approvals Table (in User's Manual)

Note

Fuses are available as spare parts from Siemens.

Fuse information can be found at:

<http://www.bussmann.com>

20.8 Changes to Module Specifications

Changes to 8-Channel HART Analog Input Module (6ES7 322-7TF01-0AB0) Specifications when used with 8-Channel HART Analog Input MTA (6ES7 650-1AA61-2XX0)	
Redundant Mode	When using the MTA, the I/O module must be used in the redundant mode. For more information see Section 2.4 <i>Connecting sensors/actuators in redundant mode</i> in the HART analog modules manual, 08/2007, A5E00434623-03.
±20 mA input range	The ±20 mA input range can not be used.
Combining 2 wire and 4 wire transducers on one module.	Any combination of 2 wire and 4 wire transducers is possible. The module inputs must be configured as 4 wire transducers regardless of transducer type.

20.9

20.10 Typical Wiring Schemes

2 Wire Transducer, Non Redundant Modules Application: The transducer is connected to either Module 1 or 2 via the HAI MTA. The jumper on the HAI MTA is placed in the 2 Wire position.

2 Wire Transducer, Redundant Modules Application: The transducer is connected to both Module 1 and 2 via the HAI MTA. The jumper on the HAI MTA is placed in the 2 Wire position.

Figure 20–2 Two Wire Analog Input Current Input Connection. Only the basic HAI MTA circuitry is illustrated.

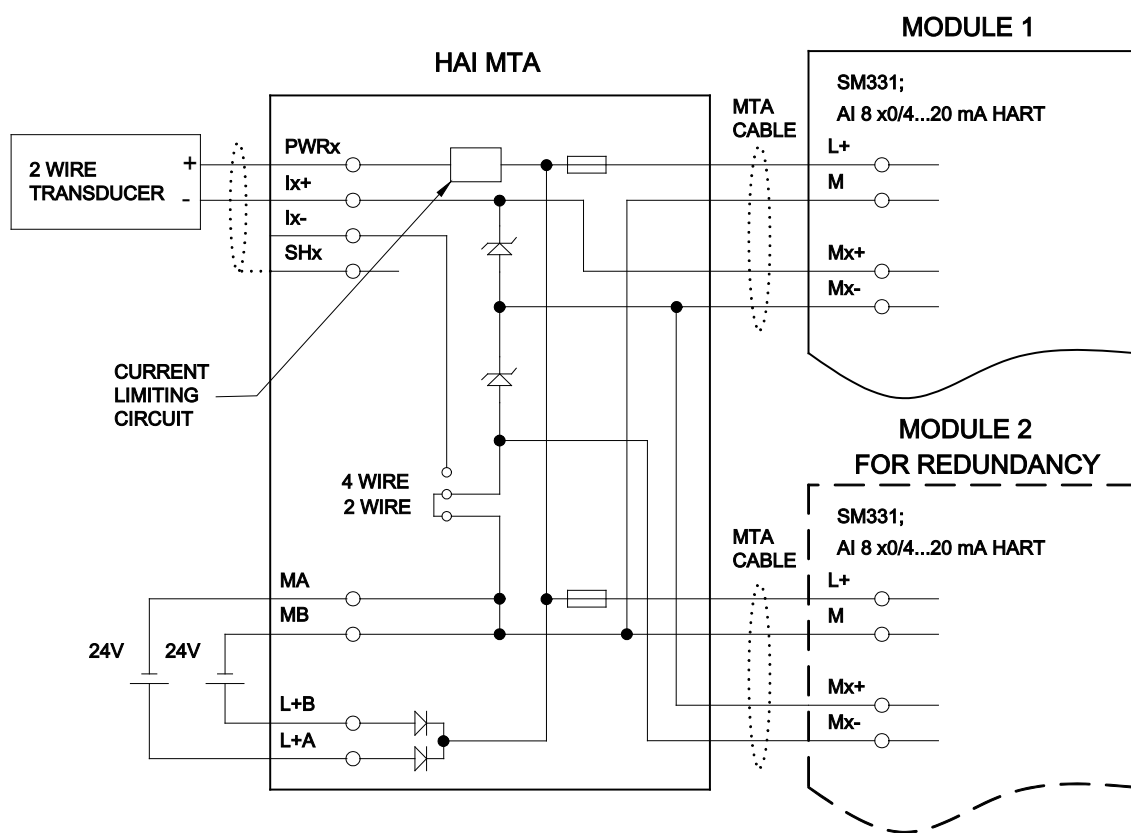

4 Wire Transducer, Non Redundant Modules Application: The transducer is connected to either Module 1 or 2 via the HAI MTA. The jumper on the HAI MTA is placed in the 4 Wire position.

4 Wire Transducer, Redundant Modules Application: The transducer is connected to both Module 1 and 2 via the HAI MTA. The jumper on the HAI MTA is placed in the 4 Wire position.

Figure 20–3 Four Wire Analog Input Current Input Connection. Customer must provide power to the transducer. Only the basic HAI MTA circuitry is illustrated.

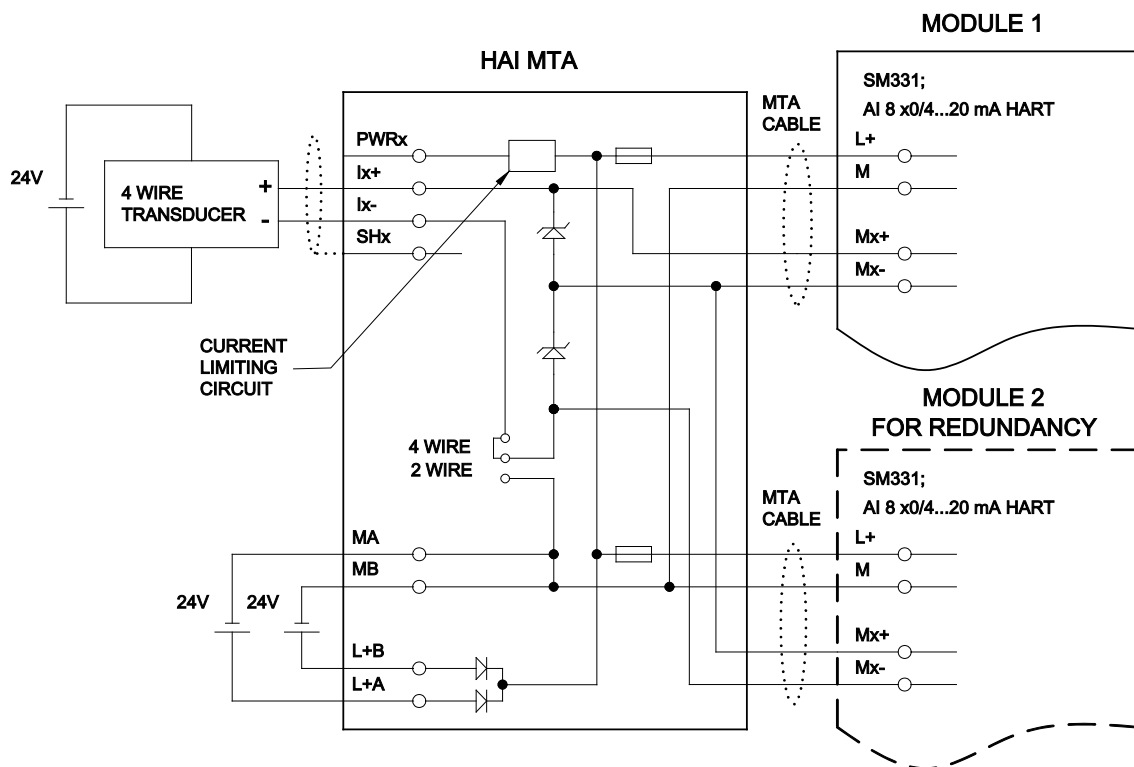

20.11 Hardware Configuration

Use the **2 – 4** jumpers to select either 2 or 4 wire transducer.

See Figure 20–1 Item 5, for the location of the shield isolation jumpers and Item 9, for the location of the **2 – 4** jumpers.

20.11.1 Addresses

Non-redundant Operation

The choice of the Input Address and Process Image are left to the user.

Redundant Operation

Process Image should be set to something other than the default. The choice of the Input Address is left to the user.

20.11.2 Inputs

The inputs must be configured as 4 wire transducers.

20.11.3 Redundancy

For non-redundant operation the value of the **Redundancy** field should be **None**.

20.12 Technical Specifications for 8-Channel HART Analog Input Module (6ES7 331-7TF01-0AB0)

Note

For a complete functional description and the most current technical specifications for this module, refer to the manual *ET 200M distributed I/O device HART analog modules* (document number A5E00434623).

21 8-Channel HART Analog Output MTA

Part No. 6ES7650-1AB61-2XX0

21.1 Description

This section contains information and requirements to facilitate installation of Siemens Marshalled Termination Assembly (MTA) (6ES7650-1AB61-2XX0), designed to interface with the Siemens ET 200M 8-Channel HART Analog Output Module (6ES7 332-8TF01-0AB0).

21.2 Features

The following features have been incorporated into this MTA:

- Redundant power connections
- LED indication for each power supply
- Power monitor plug-in available (optional)
- Dual connectors for redundant I/O Module operation
- Per module power fusing
- Shield connections available for channel cabling
- Ground stud for connecting shield to earth ground
- Power input and field terminations are pluggable for easy maintenance
- Connectivity for HART Handheld Terminal (HHT) per channel

21.3 Operation

Power is supplied via the two removable power connectors which are retained by screws and marked **L+A, MA**, and **L+B, MB**. Each has circuitry to detect the presence of voltage over 15VDC and turn on the LED indicator. The LEDs are marked **A POWER** and **B POWER**. There is also a connector for a Power Monitor board used to indicate the presence of both A and B power. See section 16 Power Monitor Board (6ES7650-1BA02-0XX0).

Incoming power from **A** and **B** is diode OR'd to provide the MTA and the module power from either input source. The output from the ORing diode is sent to the I/O modules via the module fuses.

Field Terminals, Channel + (**CHx+**), Channel – (**CHx-**), and Shield (**SHx**), connect to the field devices. **CHx+** is the current output source and **CHx-** is the current output sink. The I/O module outputs are diode OR'd, on the I/O module, before connecting to **CHx+** of the Field terminals. Redundant operation uses two modules, while non-redundant systems have one module connected to either I/O module connector

The field termination connectors are removable for ease of wiring maintenance and are retained by friction.

21.4 Installation Requirements

See Section 2 Installation, before performing any installation and observe all warnings

A common interconnecting cable (6ES7922-3BD01-0AM0 or 6ES7922-3BJ01-0AM0), supporting eight analog input channels, connects the analog input termination assembly to the 8-channel analog input module (6ES7 331-7TF01-0AB0). See Figure 4–1.

It may be necessary to modify the cable shield connections on the printed circuit board.

Note

To disconnect the interconnecting cable shield from ground at the MTA only, cut and remove the shield disconnect jumpers, **Module 1** and **Module 2**, for the associated cable.

21.5 Maintenance

See Section 3 Maintenance, before performing any maintenance and observe all warnings.

Under normal operation, the **A/B Power LEDs** and **Module 1/2 Fuse LEDs** are green. If all are off, check the power supply to MTA. If **Module 1/2 Fuse LED** is off, check the module fuse and replace if necessary

21.6 8-Channel HART Analog Output Marshallled Termination Assembly

Figure 21–1 below shows the basic parts of the 8-Channel HART Analog Output MTA.

Figure 21–1 8-Channel HART Analog Output Marshallled Termination Assembly (6ES7650-1AB61-2XX0)

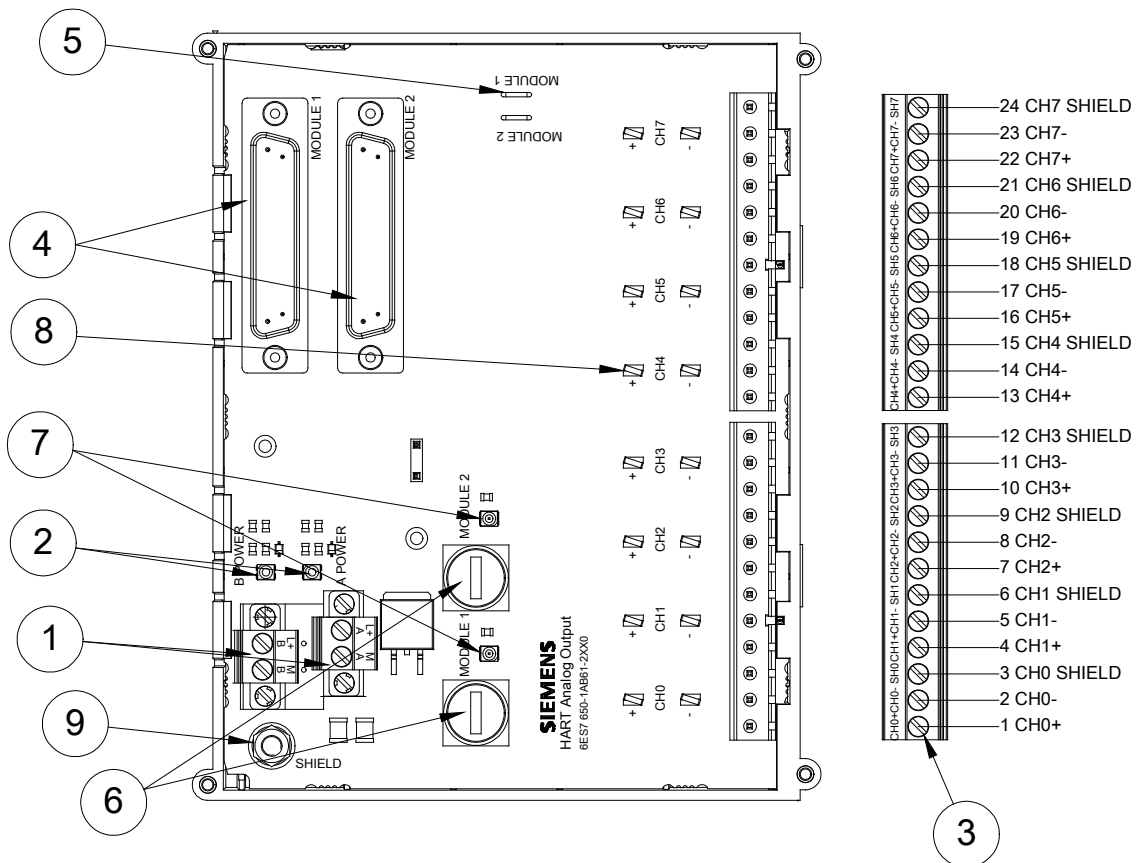

Key to numbered items in Figure 21–1:	
Item	Description
1	Input power connections
2	Input power indicators
3	Field wiring connections
4	I/O module connections (Module 1 & 2)
5	Shield disconnect jumper (Module 1 & 2)
6	Module power fuses
7	Module power indicators
8	HART Handheld connectivity (1 of 16)
9	Ground stud for connecting shield to earth ground

21.7 Technical Specifications

Technical Specifications for 8-Channel HART Analog Output MTA (6ES7650-1AB61-2XX0)	
Dimensions - See Section 1, Figure 1.3, Short Version	
Mounting	
DIN Rail	35mm (deep or shallow; with panel mounted DIN rail only deep)
Power Input	
Voltage Input for Single or Redundant Feed	21.6 to 28.8 VDC
Current Consumption (nominal ratings; all channels connected, redundant modules)	
All output channels at 20mA	0.50 A Maximum
Power Dissipation (typical)	1 W
Terminal Block Wire Sizes	
Wire Size – US	24 – 14 AWG
Wire Size – Metric	0,205 – 2,08 mm sq.
Electrical Isolation	
Between the channels and shield	Yes
Between the channels	No
Between the channels and load voltage L+	Yes
Between the shield and load voltage L+	Yes
Permissible potential difference	
Between the channels and shield (U _{ISO})	75 VDC 60 VAC
Between the channels and load voltage L+	75 VDC 60 VAC
Between the shield and load voltage L+	75 VDC 60 VAC
Insulation tested	
Channels to shield and load voltage L+	With 500 VDC
Shield to load voltage L+	With 500 VDC
Between the channels	No
Fuse Ratings / Current Limiting	
Module	0.5 A (Bussmann P/N: GMA-0.5A) (Siemens Spare P/N: A5E01568885)
Indicators	
Input Power	Green LED on when input power available, red LED on if power supply is reversed
Module Fuse OK	Green LED on when module power available

Field Terminals	
Wire Size – US	24 – 14 AWG
Wire Size – Metric	0,205 – 2,08 mm sq.
Environmental	
Ambient Temperature	-25C to +60C
Humidity	5% to 95% Non-condensing
Approvals	
MTA Agency Approvals	See Preface section, Approvals Table (in User's Manual)

Note

Fuses are available as spare parts from Siemens.

Fuse information can be found at:

<http://www.bussmann.com>

21.8 Module Restrictions

Changes to 8-Channel HART Analog Output Module (6ES7 322-8TF01-0AB0) Specifications when used with 8-Channel HART Analog Output MTA (6ES7 650-1AB61-2XX0)
None

21.9 Typical Wiring Schemes

Non-Redundant Module Application: The load or actuator is connected to either Module 1 or 2 via the AOH MTA.

Redundant Modules Application: The load or actuator is connected to both Module 1 and Module 2 via the AOH MTA.

Figure 21–2 Typical wiring scheme for connecting load field terminals. Only the basic AOH MTA circuitry is illustrated.

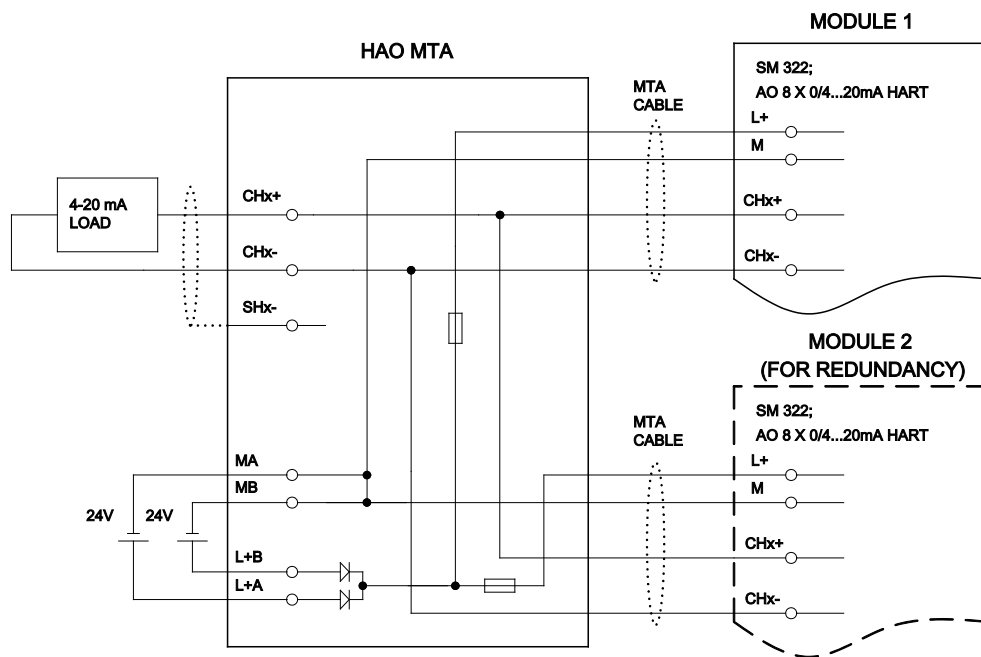

21.10 Hardware Configuration

The HART Analog Output MTA has no jumpers that affect the Module Hardware Configuration.

Note

Redundant Operation. If a redundant HART Analog Output Module loses power (module fuse opens) or is removed from service, then the output current will drop to 50% of its value for several controller cycles.

21.10.1 Addresses

Non-redundant Operation

The choice of the Input Address and Process Image are left to the user.

Redundant Operation

Process Image should be set to something other than the default. The choice of the Input Address is left to the user.

21.10.2 Outputs

For normal operation set **Type of Output** to current (I). The +/- 20 mA output range is not possible due to the MTA Design. All other Module hardware configuration choices under the **Outputs** tab are left to the user.

21.10.3 Redundancy

For non-redundant operation the value of the **Redundancy** field should be **None**.

21.11 Technical Specifications for 8-Channel HART Analog Output Module (6ES7 332-8TF01-0AB0)

Note

For a complete functional description and the most current technical specifications for this module, refer to the manual *ET 200M distributed I/O device HART analog modules* (document number A5E00434623).

22 16-Channel, 24 VDC Power Supply MTA

Part No. 6ES7650-1BE10-3XX0

22.1 Description

This section contains information and requirements to facilitate installation of Siemens Marshalled Termination Assembly (MTA) (6ES7650-1BE10-3XX0), designed to energize 4-wire transducers

22.2 Features

The following features have been incorporated into this MTA:

- Redundant power connections
- LED indication of redundant power supply operation
- LED indication of reverse polarity
- Power monitor output
- Short circuit detection on the outputs
- 16 outputs rated at 24V/ 0.5A
- each output electronically short circuit protected
- one LED per output
- Shield connections available for channel cabling
- Ground stud for connecting shield to earth ground

22.3 Operation

The modules

8-Channel Analog Input MTA (6ES7 650-1AA52-2XX0)

6-Channel F Analog Input HART MTA (6ES7 650-1AA62-5XX0)

8-Channel Analog Input HART MTA (6ES7 650-1AA61-2XX0)

provide a supply only for 2-wire- and not for 4-wire transducer.

This gap will be filled by the 16-Channel Power Supply MTA. The MTA provides 16 outputs rated at 24V/0.5A. In case 0.5A is not sufficient for energizing the transducer, two or more outputs of the same MTA can be connected in parallel. The outputs are individually short circuit protected without using destructible fuses. In case one or more outputs are short circuited, there is no influence on the remaining outputs.

Power is supplied via the power connector marked **L+A, MA**, and **L+B, MB**. Each has a green LED to indicate the presence of voltage over 15 VDC. In the case of polarity reversal of the power supply, the LEDs will illuminate red. The LEDs are marked **A POWER** and **B POWER**.

Incoming power from **A** and **B** is diode OR'd to provide the MTA from either power source. The output from the dual diode is used to supply the 16 outputs of the MTA.

One green LED per output signals the power availability for this channel.

An onboard Power Monitor System (PMS) is used to provide an isolated dry contact when redundant power is supplied to MTAs. Only when power is supplied to both power inputs the output contacts **1** and **2** are closed. The Power Monitor System is designed to detect only the presence or absence of power. It is not designed to detect supply voltage which is outside the specification threshold.

An onboard Short Circuit Detection (SCD) is used to provide an isolated dry contact in case one or more outputs will be short circuited. For a few seconds after applying or removing the short circuit, the dry contact may toggle before providing a stable ON or OFF status.

Field Terminals, Power+ (**PWR+**), Ground (**Mx**), and Shield (**SHx**), connect to the field devices. **PWRx** provides the transducer supply current. **Mx** is the transducer power return.



Caution

The heat sink can be over 100 °C. Avoid contact during servicing.

22.4 Installation Requirements

See Section 2, *Installation*, before performing any installation and observe all warnings

22.5 Maintenance

See Section 3, *Maintenance*, before performing any maintenance and observe all warnings

Under normal operation, the **A/B Power LEDs** are illuminated green. If an **A/B Power LED** is illuminated red (or off), check the power supply to the MTA.

Under normal operation the 16 LEDs on the outputs are illuminated green. If one or more LEDs are off, check the cabling or load for a short circuit.

22.6 Simplified diagram

Figure 226-1 16-Channel, 24VDC Power Supply Marshallled Termination Assembly (6ES7650-1BE10-3XX0)

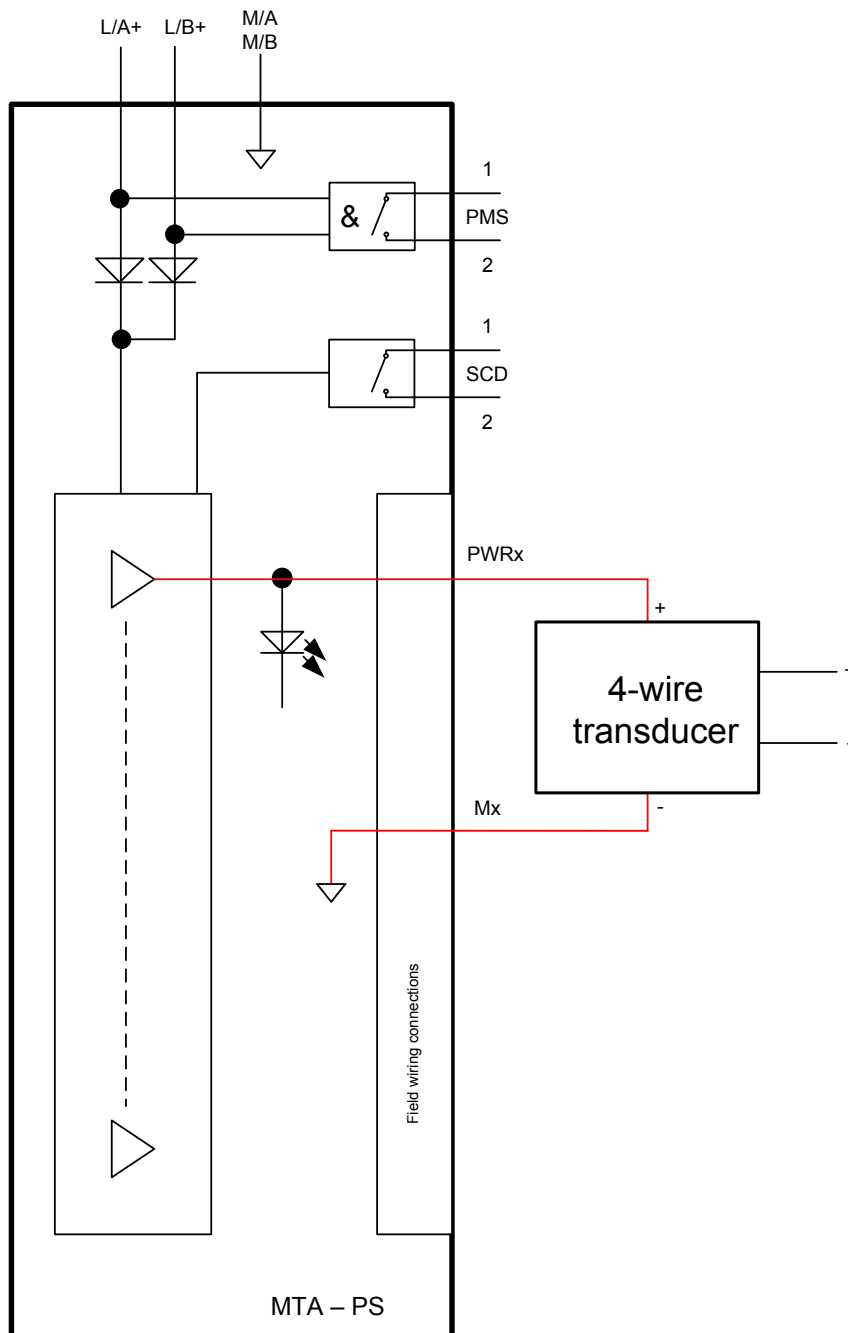

22.7 Component Identification

Figure 226-2 16-Channel, 24 VDC Power Supply Marshalled Termination Assembly (6ES7650-1BE10-3XX0)

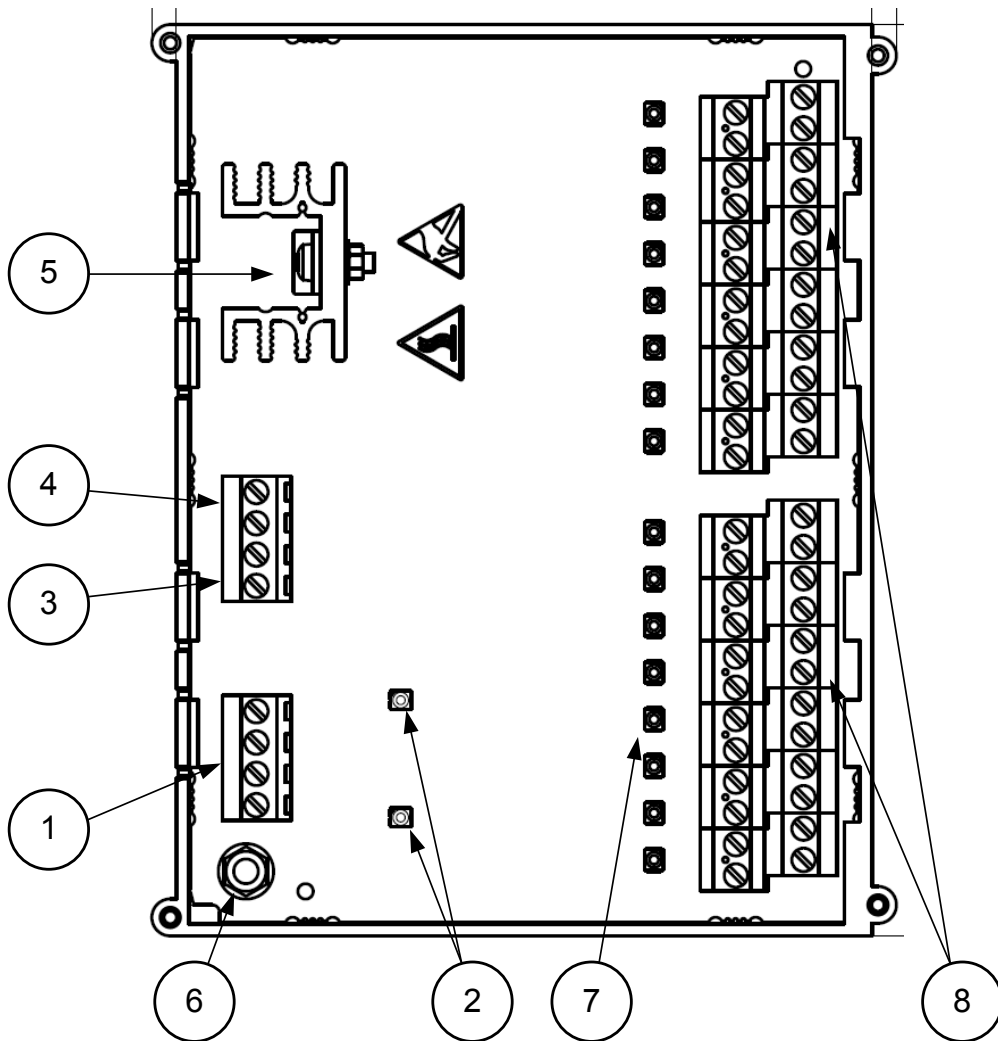

Key to numbered items in Figure 15-1:	
Item	Description
1	Input power connections (Power A, Power B)
2	Input power indicators (Power A, Power B)
3	Output Power Monitor System
4	Output Short Circuit Detection
5	Heat sink
6	Ground stud for connecting shield to earth ground
7	Output status indicators (1 ... 16)
8	Field wiring connections

22.8 Technical Specifications

Technical Specifications: 16-Channel, 24 VDC Power Supply MTA (6ES7650-1BE10-3XX0)	
Dimensions - See Section 1, Figure 1.3, Short Version	
Mounting	
DIN Rail	35mm (deep top hat style)
Orientation	horizontal or vertical
Power Input	
Voltage Input for Single or Redundant Feed	21.6 to 28.8 VDC
Total current	
to 40°C	8.1 A maximum
to 60 °C	5.1 A maximum
without load	0.1 A maximum
Power Dissipation (typical)	5W
Power Output per channel	
Output voltage	min L+ - 1.2V
Output current	0.5A
Short circuit protection	yes, electronic
• Threshold	ca. 1A
Wiring two or more outputs of the same MTA in parallel for increased performance	supported
Wiring two or more outputs of different MTAs in parallel for increased performance	not supported
Power Output per module	
Output current	Total 8A max at Ta = 40°C Total 5A max at Ta = 60°C
Power Monitoring System - Output Contact Ratings	
Threshold voltage	ca. 15 V
Maximum switched Voltage	30 V DC
Maximum switched Current	0.5 A resistive load; not short circuit protected
Short Circuit Detection - Output Contact Ratings	
Maximum switched Voltage	30 V DC
Maximum switched Current	0.5 A resistive load; not short circuit protected

Indicators	
Input Power	Green LED on when input power available, Red LED on when power polarity is reversed
Power Output Status	Green LED
Field Connections	
Wire Size US	24 to 14 AWG
Wire Size metric	0.2 to 2.08 mm ²
Environmental	
Ambient Temperature	-25°C to +60°C
Humidity	5% to 95% Non-condensing
Approvals	
MTA Agency Approvals	See Preface section, Approvals Table

22.9 Typical Load Connection to Field Terminals

Figure 226-3 Load Connection to Field Terminals of 16-Channel, 24 VDC Power Supply MTA

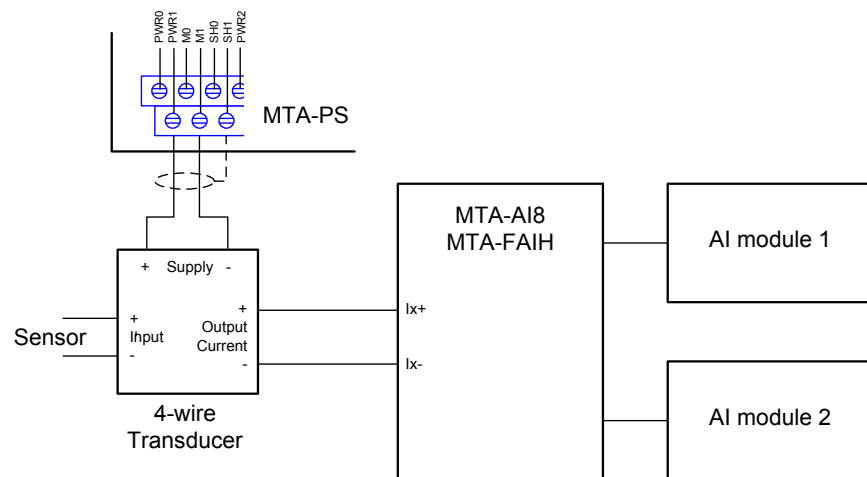

22.10 Hardware Configuration

In PCS7 no HW Configuration will be necessary

23 Previous MTA Revisions

This section contains information about previous revisions of the ET200M MTAs.

23.1 8 Channel Analog Input MTA

Part No. 6ES7650-1AA50-2XX0

8-Channel Analog Input Marshalled Termination Assembly

Figure 23–1 8-Channel Analog Input Marshalled Termination Assembly (6ES7650-1AA50-2XX0)

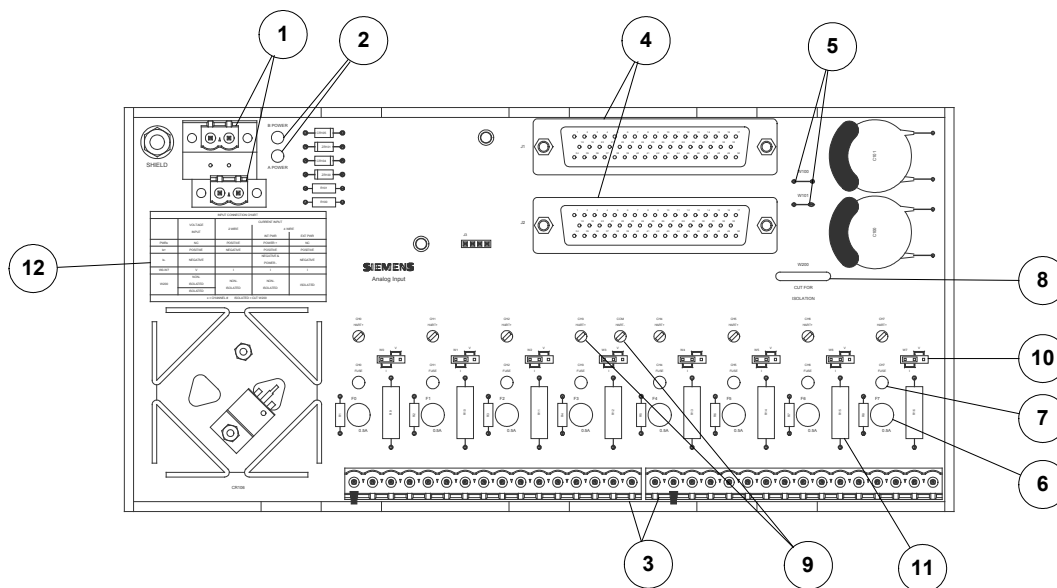







Key to numbered items in Figure 23-1:	
Item	Description
1	Input power connections
2	Input Power Indicators
3	Field Connections
4	I/O Module Connections (J1 & J2)
5	Shield disconnect jumper (W100 & W101)
6	Field power fuses
7	Field power indication (1 of 8)
8	Input Isolation Jumper (W200)
9	HART connectivity
10	Input Mode Jumper (I – V)
11	250 Ω resistors (R1-R8)
12	Input Connection Chart

24 Safety Information for US Customers

Conventions and Symbols

The following symbols may appear in this manual and may be applied to the equipment. The reader should become familiar with the symbols and their meaning. Symbols are provided to quickly alert the user to safety related situations, issues, and text.

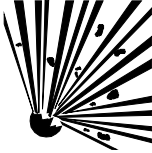
Symbol	Meaning
 DANGER	Indicates an immediate hazardous situation which, if not avoided, <i>will</i> result in death or serious injury.
 WARNING	Indicates a potentially hazardous situation which, if not avoided, <i>could</i> result in death or serious injury.
 CAUTION	Indicates a potentially hazardous situation which, if not avoided, <i>may</i> result in minor or moderate injury.
CAUTION	Indicates a potentially hazardous situation which, if not avoided, may result in property damage.
NOTICE	Indicates a potential situation which, if not avoided, may result in an undesirable result or state.
Important	Identifies an action that should be taken to avoid an undesirable result or state.
Note	Identifies additional information that should be read.
	Electrical shock hazard. The included Warning text states that the danger of electrical shock is present.
	Electrical shock hazard. Indicated that the danger of electrical shock is present.

Symbol	Meaning
	<p>Explosion hazard. Indicates that the danger of an explosion hazard exists.</p>
	<p>Electrostatic discharge. The presence of this symbol indicates that electrostatic discharge can damage the electronic assembly.</p>
	<p>Hot Surface. Indicates the danger of getting burned is present.</p>

Qualified Persons

The described equipment should be installed, configured, operated, and serviced only by qualified persons thoroughly familiar with this publication. The current version, in Portable Document Format (PDF), is available at <http://sitiescape.sea.siemens.com/>.

For the purpose of this publication and product labels, a qualified person is one who is familiar with the installation, construction, and operation of the equipment, and the involved hazards. In addition, he or she has the following qualifications:

- Is trained and authorized to energize, de-energize, clear, ground and tag circuits and equipment in accordance with established safety practices.
- Is trained in the proper care and use of protective equipment such as rubber gloves, hard hat, safety glasses or face shields, flash clothing, etc., in accordance with established safety practices.
- Is trained in rendering first aid.

General Warnings and Cautions



This equipment contains hazardous voltages, and it has been certified for use in the hazardous locations specified on the product nameplate and in the Model Designation and Specifications section. Death, serious personal injury, or property damage can result if safety instructions are not followed. Only qualified personnel should work on or around this equipment after becoming thoroughly familiar with all warning, safety Notes, and maintenance procedures contained herein. The successful and safe operation of this equipment is dependent upon proper handling, installation, operation, and maintenance.

The perfect and safe operation of the equipment is conditional upon proper transport, proper storage, installation and assembly, as well as, on careful operation and commissioning.

The equipment may be used only for the purposes specified in this publication.



Electrostatic discharge can damage or cause the failure of semiconductor devices such as integrated circuits and transistors. The symbol at right may appear on a circuit board or other electronic assembly to indicate that special handling precautions are needed.



- A properly grounded conductive wrist strap must be worn whenever an electronics module or circuit board is handled or touched. A service kit with a wrist strap and static dissipative mat is available from Siemens (PN15545-110). Equivalent kits are available from both mail order and local electronic supply companies.
- Electronic assemblies must be stored in anti-static protective bags when not installed in equipment.

