



Instruction manual



Fuji Electric-General-Purpose Inverter FVR-C11S-7EN Series

Single-phase 230V 0.1 - 2.2kW

Contents

Safety Instructions	1	8 Maintenance and Inspection	8-1
1 Before Using This Product	1-1	8-1 Daily Inspection	8-1
1-1 Receiving Inspections	1-1	8-2 Periodic Inspection	8-1
1-2 Appearance	1-2	8-3 Electrical measurements in the Main Circuit	8-5
1-3 Handling the Product	1-3	8-4 Insulation Test	8-6
1-4 Carrying	1-4	8-5 Parts Replacement	8-7
1-5 Storage and transportation	1-4	8-6 Inquiries about the Product and Guarantee of the product	8-7
2 Installation and Connection	2-1	9 Specifications	9-1
2-1 Operating Environment	2-1	9-1 Standard Specifications	9-1
2-2 Installation Method	2-2	9-2 Common Specifications	9-2
2-3 Connection	2-3	9-3 Dimensions	9-8
2-3-1 Basic connection	2-3	9-4 Selection of Peripheral Device	9-11
2-3-2 Connecting the main circuit and ground terminals	2-4	10 Options	10-1
2-3-3 Connecting the control terminals	2-6	10-1 Built-in Options	10-1
2-3-4 Connection examples	2-12	10-2 External Options	10-1
2-4 Others	2-21	11 Applicable reactors	11-1
2-4-1 Harmonic component	2-21	12 Compliance with standards	12-1
2-4-2 Noise	2-21	12-1 UL/cUL standards [Applicable to products with UL/cUL mark]	12-1
2-4-3 Leakage current	2-21	12-1-1 General	12-1
3 Operation	3-1	12-1-2 Precautions	12-1
3-1 Inspection and Preparation before Operation	3-1	12-2 Compliance with EMC directive in EU [Applicable to products with CE mark]	12-2
3-2 Operation Method	3-1	12-2-1 General	12-2
3-3 Trial Run	3-2	12-3 Compliance with low voltage directive in EU [Applicable to products with TÜV or CE mark]	12-2
4 Keypad Panel	4-1	12-3-1 General	12-2
4-1 Names and Functions	4-1	12-3-2 Precautions	12-2
4-2 Operating Keypad Panel	4-1	13 Electromagnetic Compatibility (EMC)	13-1
5 Selecting Function	5-1	13-1 General	13-1
5-1 Function Selection List	5-1	13-2 RFI Filters	13-1
5-2 Details of Each Function	5-7	13-3 Recommended Installation Instructions	13-3
6 Protective Function	6-1		
6-1 List of protective functions	6-1		
6-2 Alarm Reset	6-3		
7 Troubleshooting	7-1		
7-1 In case of tripping	7-1		
7-2 Other trouble	7-7		

Safety Instructions

Read this operation manual carefully and familiarize yourself with the operation of the inverter before installation, connection (wiring), operation or maintenance and inspection of the device. Be familiar with the inverter, safety information, and safety signs before using the inverter.

In this instruction manual, safety signs are classified into the following categories.



WARNING

Improper operation may result in death or serious injury.



CAUTION

Improper operation may result in slight to medium injury or property damage.

Note: More serious situations than those covered by the CAUTION sign can result depending on the circumstances. It is important that you always follow the instructions.

Compliance with UL/cUL standards [Applicable to products with UL/cUL mark]



CAUTION

1. [WARNING] Take care of electric shock. Be sure to turn the inverter off before starting work.
2. [CAUTION] When the charge lamp is lit, the inverter is still charged at a dangerous voltage.
3. [WARNING] There are two or more live parts inside the inverter.
4. The inverter is approved as a part used inside a panel. Install it inside a panel.
5. Perform wiring to the input, output and control terminals of the inverter, referring to the table below. Use UL certified round crimp terminal to the input and output terminals with insulation cover or covered with reduced tube to obtain the insulation distance. Use a crimping tool recommended by the terminal manufacturer when fabricating crimp terminals.
6. Install a fuse in the power supply to the inverter, referring to the table below.

Voltage	Inverter type	Tightening torque [Nm]		Applicable wire diameter [AWG] (mm ²) ¹⁾		Fuse [A] ²⁾	Recommended fuse	
		L1/L, L2/N U, V, W	Control section	L1/L, L2/N U, V, W	Control section		Gould Company	Busmann Company
Single-phase 200V input	FVR0. 1C11S-7EN	1.2	0.4	14 (2.1)	20 (0.5)	6	A4J6	JKS6
	FVR0. 2C11S-7EN					6	A4J6	JKS6
	FVR0. 4C11S-7EN					10	A4J10	JKS10
	FVR0. 75C11S-7EN					15	A4J15	JKS15
	FVR1. 5C11S-7EN	1.8		12 (3.3)	30	A4J30	JKS30	
	FVR2. 2C11S-7EN			10 (5.3)	40	A4J40	JKS40	

1) Use copper wires of allowable maximum temperature 60 or 75 °C.
 2) Use UL certified "quick breaking fuse".

7. Connect the power supply satisfying the characteristics shown in the table below as an input power supply of the inverter. (Short circuit rating)

Inverter type	Input max. voltage	Input current
FVR0. 1-2. 2C11S-7EN	AC240V	5,000 A or less

Compliance with low voltage directive in EU [Applicable to products with TÜV mark]



CAUTION

1. Safe separation for control interface of this inverter is provided when this inverter is installed in overvoltage category II. PELV (Protective Extra Low Voltage) circuit or SELV (Safety Extra Low Voltage) circuit from external controller is connected to the interface directly.
2. Basic insulation for control interface of this inverter is provided when this inverter is installed in overvoltage category III. An insulation transformer has to be installed between power supply mains and this inverter when SELV circuit from external controller is connected to this inverter directly. Otherwise supplementary insulation between control interface of this inverter and environment must be provided.
3. The ground terminal G should always be connected to the ground. Don't use only RCD as the sole method of electric shock protection. Dimensions of external PE conductor should be same as dimensions of input phase conductor and capable for possible fault.
4. Use MCCB or MC that conforms to EN or IEC standard.
5. Where RCD (Residual-current-operated protective device) is used for protection in case of direct or indirect contact, only **RCD of type B** is allowed on the supply side of this EE (Electric equipment). Otherwise another protective measure shall be applied such as separation of the EE from the environment by double or reinforced insulation or isolation of EE and supply system by the transformer.
6. The inverter has to be installed in environment of pollution degree 2. If the environment is pollution degree 3 or 4, the inverter has to be installed in a cabinet of IP54 or higher.
7. Use a prescribed wire according to the EN60204 Appendix C.
8. Install the inverter, AC or DC reactor, output filter in an enclosure that meets the following requirement, to prevent a human body from touching directly to these equipment.
 - 1) When a person can touch easily on each connecting terminal or live parts, install the inverter, AC or DC reactor, output filter in an enclosure with minimum degree of protection of IP4X.
 - 2) When a person can not touch easily on each connecting terminal or live parts, install the inverter, AC or DC reactor, output filter in an enclosure with a minimum degree of protection of IP2X.
9. It is necessary to install the inverter in appropriate method using an appropriate RFI filter to conform to the EMC directive. It is customer's responsibility to check whether the equipment, the inverter is installed in, conforms to EMC directive.

Compliance with low voltage directive in EU [Continued]



CAUTION

Use of wires specified in Appendix C of EN 60204 is recommended.

Power supply voltage	Nominal applied motor [kW]	Inverter type	Molded case circuit breaker (MCCB) or earth leakage circuit breaker (ELCB) ¹⁾ Rated current [A]		Recommended wire size [mm ²]				
					Input circuit ²⁾ single phase 200V [L1/L, L2/N]		Output circuit ²⁾ [U, V, W]	DCR ²⁾ circuit [P1] [P(+)]	Control wiring
					With DCR	Without reactor ³⁾			
Single phase 200V	0.1	FVR0. 1C11S-7EN	6	6	2.5 ⁴⁾	2.5 ⁴⁾	2.5 ⁴⁾	2.5 ⁴⁾	0.5
	0.2	FVR0. 2C11S-7EN		6					
	0.4	FVR0. 4C11S-7EN		10					
	0.75	FVR0. 75C11S-7EN	10	16		4.0 ⁴⁾			
	1.5	FVR1. 5C11S-7EN	16	20		6.0 ⁵⁾			
	2.2	FVR2. 2C11S-7EN	20	32		4.0 ⁵⁾			

- 1) The applicable frame and series of the molded case circuit breaker (MCCB) and earth leakage circuit breaker (ELCB) vary according to the capacity of the transformer of the equipment. For details of selection, refer to the concerning technical documents.
- 2) The recommended wire size for the main circuit is the case for the low voltage directive at ambient temperature 40 °C.
- 3) The power supply impedance without a reactor is considered to be the equivalent of 0.1% of the inverter capacity, with 10% current imbalance accompanied by the voltage imbalance.
- 4) Crimp terminals up to 7.4 mm in width (including tolerance) can be used.
- 5) Crimp terminals up to 9.5 mm in width (including tolerance) can be used.
- 6) Use the grounding cable of a size equal to or larger than that of the input power supply cable.

Instructions on use



WARNING

1. This inverter is designed to drive a three-phase induction motor and is not usable for a single-phase motor or any other purposes.
There is a risk of fire.
2. This inverter may not be used as is for an elevator, life-support system, or other purpose directly affecting the safety of humans.
Safety precautions should be established and practiced in terms of the entire system, rather than the independent device.
Otherwise, an accident could occur.

Instructions on transport/installation



WARNING

1. Attach the device to an incombustible material such as metal.
Otherwise fire could occur.
2. Do not place the device near inflammables.
Otherwise fire could occur.



CAUTION

1. Do not carry the device by holding just the surface cover.
Inverter may be dropped causing injury.
2. Do not allow foreign matter such as lint, paper dust, small chips of wood or metal, and dust to enter the inverter or adhere to the heat sink.
Otherwise, a disaster such as burning could occur.
3. Do not install or operate damaged inverter or an inverter with a missing part.
Otherwise injury could occur.
4. Do not step on the product.
Otherwise injury could occur.
5. When stacking up in tiers, do not exceed the number of tiers indicated on the packing carton.
Otherwise injury could occur.

Instructions on wiring



WARNING

1. When the inverter is connected to power, connect it via a line-protection molded case circuit breaker or an earth-leakage circuit breaker (Residual current operated protective device).
Otherwise fire could occur.
2. Be sure to connect the ground wire.
Otherwise electric shock or fire could occur.
3. Ensure that a licensed specialist performs the wiring work.
4. Check before starting the wiring that the power is off (OPEN).
Otherwise electric shock could occur.
5. Do not wire up the inverter until it has been installed securely.
Otherwise electric shock or injury could occur.
6. The inverter has to be grounded in accordance with the national and local safety specification.
Otherwise electric shock could occur.



CAUTION

1. Check that the number of phases and the rated voltage of this product correspond to the number of phases and voltage of the AC power supply.
Otherwise fire could occur.
2. Do not connect the AC power supply to the output terminals (U, V, W).
Otherwise injury could occur.
3. Check the output terminals (U,V,W) for the phase order and connect them to the motor correctly.
Otherwise fire could occur.
4. Do not connect a braking resistor directly to the DC terminals [P(+), N(-)].
Otherwise fire could occur.
5. Noise is generated from the inverter, motor, and wiring. Take care that this noise does not cause malfunctions in peripheral sensors and equipment.
Otherwise accidents could occur.

Instructions on operation



WARNING

1. Be sure to put on the surface cover before turning the power ON (CLOSE).
Never remove the cover while the power is applied to the inverter.
Otherwise electric shock could occur.
2. Never operate switches with wet fingers.
Otherwise electric shock could occur.
3. The interior of the inverter may remain charged after turning off the power.
Therefore, never attempt to remove the surface cover except for wiring service and periodic maintenance.
Otherwise electric shock could occur.



WARNING

1. When the retry function is selected, the inverter may automatically restart after tripping, depending on the cause of the trip.
(Design the machine to secure personal safety in the event of restart.)
Otherwise accident could occur.
2. Operating conditions may occasionally be different from the preset acceleration/deceleration time or speed because of activation of the stall prevention function.
In such a case, personal safety must be secured through adequate machine design.
Otherwise accident could occur.
3. The stop key is effective only when a function setting has been established.
Therefore install an emergency switch independently. When operation via the external signal terminal is selected, the STOP key on the keypad panel will be disabled.
There is a risk of accidents.
4. Operation starts suddenly if alarm reset is done with an running signal input. Check that no running signal is input before alarm reset.
Otherwise accidents could occur.

5. Never touch the inverter terminals when energized even if it has stopped.
Otherwise electric shock could occur.
6. Never touch the keys on the keypad panel with a pointed object such as a needle.
Otherwise electric shock could occur.



CAUTION

1. Never touch the heat sink because they become very hot.
Otherwise burns could occur.
2. The inverter can set high-speed operation easily. Carefully check the limit of the motor and machine before changing the setting.
Otherwise injuries could occur.
3. Do not use the inverter brake function for mechanical holding.
Otherwise injuries could occur.

Instruction on maintenance/inspection, and replacement



WARNING

1. Do not commence inspection work until at least five minutes after the power has been turned off (OPEN).
(In addition, make sure that the charge lamp has gone off and check that the DC voltage between terminals P(+) and N(-) does not exceed 25V DC.)
Otherwise electric shock could occur.
2. Only qualified personnel should perform maintenance and inspection or replacement operations.
(Take off all metal objects (watch, ring, etc.) before starting.)
(Use well-insulated tools.)
Otherwise electric shock or injury could occur.
3. Never modify the product.
Otherwise electric shock or injury could occur.

Instruction on disposal



CAUTION

Since this product contains lead solder, it must be treated as industrial waste when it is disposed of. Entrust it to a waste processing company when disposing it.

General instructions

The figures in this operation manual may show the inverter with covers and safety screens removed to explain the structure in details. Therefore, be sure to replace the covers and screens to their original positions and operate the inverter according to the instruction manual.

1 Before Using This Product

1-1 Receiving Inspections

Unpack and check the product as explained below.

If you have any questions or problems with this product, please contact FUJI ELECTRIC Co., Ltd., or your local FUJI inverter distributor.

- 1) Check the ratings name plate to confirm that the delivered product is the ordered one.

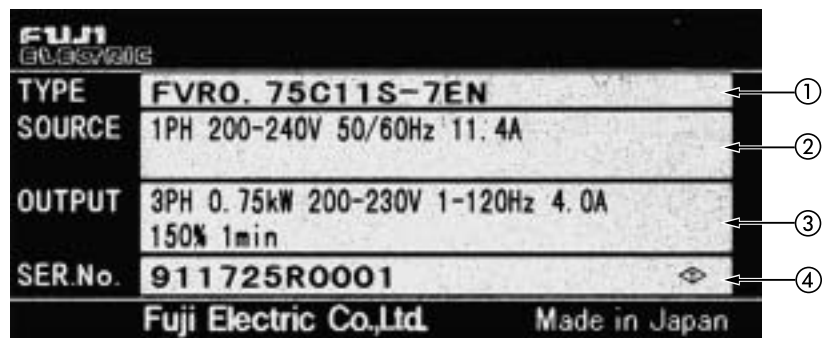

Figure 1-1-1 Ratings nameplate

- ① TYPE: Inverter Type

FVR 0.75 C11S - 7 EN

Series Extension (EN series)

Power voltage series:

7 → Single-phase 200V input series

Series name

Nominal applied motor: 0.75 → 0.75kW

Product type

- ② SOURCE: Number of input phases, rated input voltage, rated input frequency, rated input current
- ③ OUTPUT: Number of output phases, rated output capacity, rated output voltage, output frequency range, rated output current, overload capacity
- ④ SER. No.: Product number

9 1 1725R0001

Production lot serial number

Production month:

1 to 9: January to September,

X: October, Y: November, Z: December

Production year:

Last digit of year (9: 1999)

- 2) Check for damaged parts, missing parts, and dents or other damage on the covers or the main unit upon delivery.

1-2 Appearance

1



- ① Surface cover
- ② Keypad panel
- ③ Frequency setting POT (VR) (built-in POT)
- ④ Ratings nameplate
- ⑤ Heat sink
- ⑥ Cooling fan (1.5 kW or more)
- ⑦ Charge lamp CRG
- ⑧ Control terminal block
- ⑨ Main circuit terminal block
Single-phase 200V[⊕G,L1/L,L2/N,P1,P(+)]
- ⑩ Main circuit terminal block
[P(+),N(-),U,V,W,⊕G]

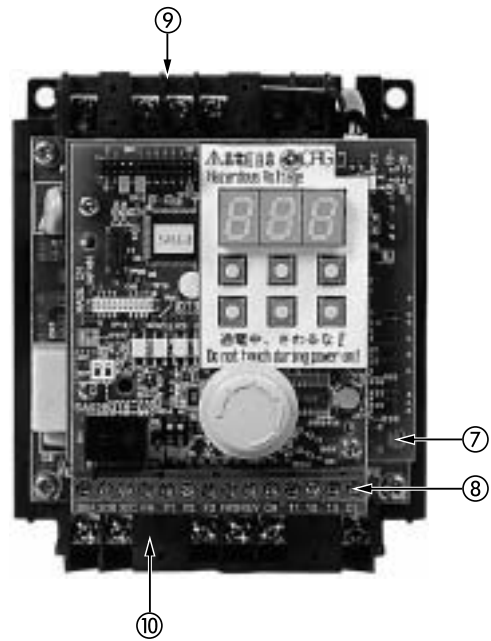
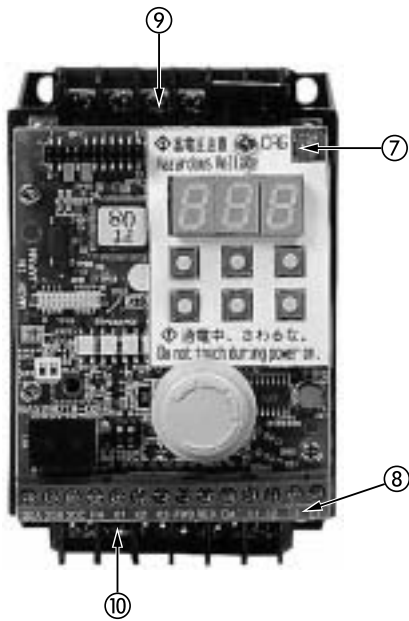
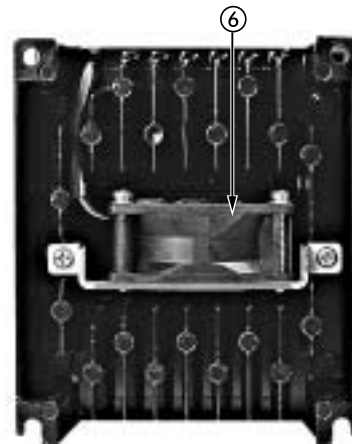
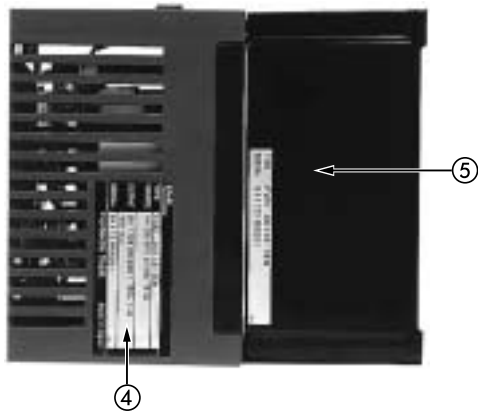

1-3 Handling the Product

Remove the surface cover as explained below.

1) For FVR0.1 to 0.75C11S-7EN

Grasp the upper and lower parts of the cover with both hands and pull it to the front of the inverter.

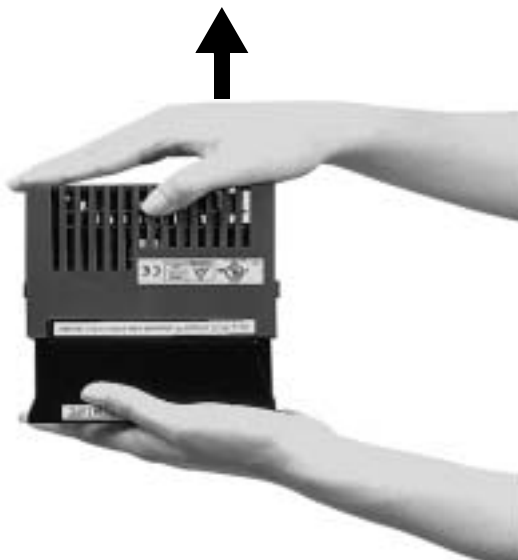

2) For FVR1.5 to 2.2C11S-7EN

Expand the lower part of the cover horizontally, lift the cover to the front, and then remove it.

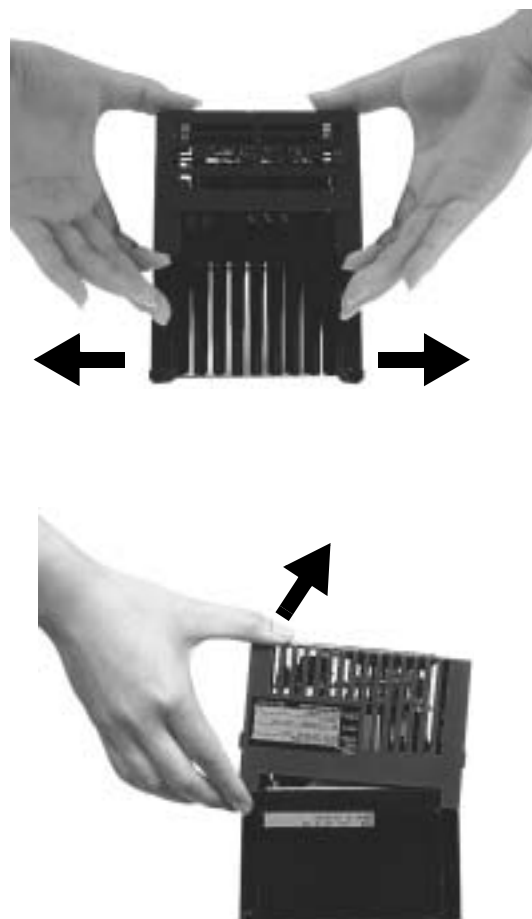

1-4 Carrying

Always hold the main unit while carrying this product.
 If it is carried by the cover or parts and not the main unit, the product may be damaged or dropped.
 Force must not be applied to the inverter cover during carrying because it is made of plastic.

1-5 Storage and transportation

Store and transportation this product under the conditions listed in Table 1-5-1.

Item	Specifications	
Storage temperature Transportation temperature	-25 to +65 °C	Condensation or formation of ice must not be caused by sudden temperature changes.
Relative humidity		
Atmosphere	The product must not be exposed to dust, direct sunlight, corrosive gas, inflammable gas, oil mist, vapor, water drops, or vibration. There must be no salt in the atmosphere.	
Air pressure	86 to 106kPa (During storage)	
	70 to 106kPa (During transportation)	

Table 1-5-1 Storage and transportation environment

1) A large change in temperature within this humidity range may cause condensation or formation of ice. Do not store this product at a place where such changes occur.

[Storage precautions]

1. Do not locate this product directly on a floor; place it on a rack or shelf.
2. To store the product in a severe atmosphere, pack it in vinyl sheet.
3. If the product must be stored at a place where it may be affected by humidity, insert a drying agent such as silica gel and pack it in vinyl sheet.

2 Installation and Connection

2-1 Operating Environment

Install this product at a place satisfying the conditions listed in Table 2-1-1.

Item	Specifications
Place	Indoor
Ambient temperature	-10 to +50 °C
Ambient relative humidity	5 to 95%RH (No condensation allowed)
Atmosphere	The product must not be exposed to dust, direct sunlight, corrosive gas, inflammable gas, oil mist, vapor, or water drops. There must be no salt in the atmosphere. Condensation must not be caused by sudden changes in temperature.
Altitude	1000 m or less (Air pressure : 86kPa to 106kPa)
Vibration	3mm: 2 ~ 9 Hz or less 9.8 m/s ² : 9 ~ 20 Hz or less 2 m/s ² : 20 ~ 55 Hz or less 1 m/s ² : 55 ~ 200 Hz or less

Table 2-1-1 Operating environment

2-2 Installation Method

1. Tightly fasten the product in the upright position on a strong structure using four bolts (M4) with the characters FVR-C11 facing the front. Be sure not to turn the product upside down, and install it on a horizontal surface.
2. Heat is generated while the inverter is operating, so the gaps shown in Figure 2-2-1 are necessary for the passage of cooling air. The generated heat is radiated upward by the built-in cooling fan, so do not install this product below a device that is sensitive to heat.

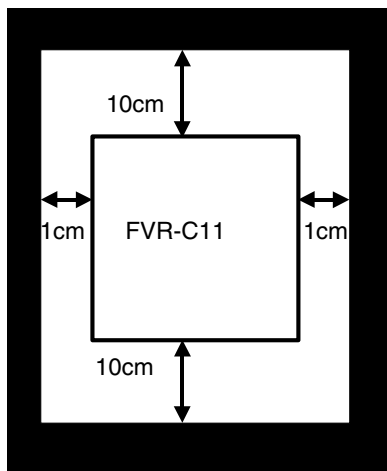

Figure 2-2-1 Installation direction and surrounding space

3. The temperature of the heat sink increases to about 90 °C while the inverter is operating. Therefore, the surface behind where the product is located must be able to withstand this temperature increase.



WARNING

Install this product on a nonflammable material such as metal.
Otherwise fire could occur.

4. When installing this product in a control panel, carefully consider the ventilation to prevent the ambient temperature of the inverter from exceeding the specified value. Do not install it in a hermetically sealed box from which heat is not radiated fully.

5. If two or more inverters need to be installed in the same device or control panel, they should be arranged horizontally to minimize the influence of heat between them. If two or more inverters must be installed vertically, place a plate between them to prevent the upper inverter from being affected by heat from the lower inverter.

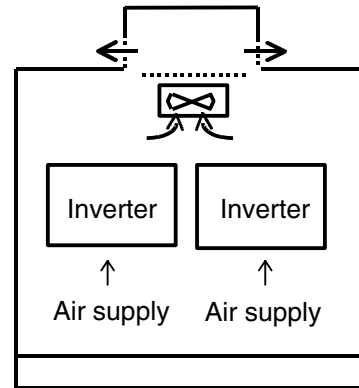

a) Horizontal arrangement

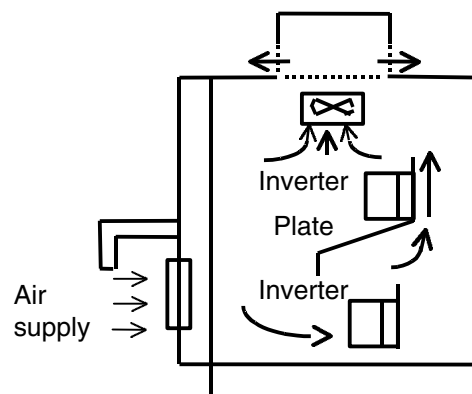

b) Vertical arrangement

Figure 2-2-2 How to install two or more inverters

**CAUTION**

Do not allow foreign matter such as lint, paper dust, small chips of wood or metal, and dust to enter the inverter or adhere to the heat sink.

Otherwise, a disaster such as burning could occur.

**WARNING**

1. Always connect the ground wire.
Otherwise electric shock and fire could occur.
2. Ensure that a licensed specialist performs the wiring work.
3. Check before starting the wiring that the power is off.
Otherwise electric shock could occur.

2

2-3 Connection

Remove the surface cover to connect the terminal blocks. Correctly connect them according to the following procedures.

2-3-1 Basic connection

1. Always connect the power to the main power supply input terminal of the inverter. If it is connected to another terminal, the inverter will be damaged (see Figure 2-3-1).
2. Always ground the ground terminal to prevent disasters such as fire and electric shock and to minimize noise.
3. Use a reliable crimp terminal for connection between a terminal and wire.
4. After terminating the connection (wiring), check the following items:
 - a. Whether the connection is correct
 - b. Whether all necessary connections have been made
 - c. Whether there is a short-circuit or ground fault between terminals and wires
5. Connection modification after power-on
The smoothing capacitor in the direct current part of the main circuit cannot be discharged quickly after the power is turned off. Use a multimeter to check that the voltage of the direct current (DC) is reduced to the safety range (25V DC or less) after the charge lamp goes off to avoid danger. Check that the voltage is zero before short-circuiting a circuit because the residual voltage (electric charge) may cause sparks.

2-3-2 Connecting the main circuit and ground terminals

Symbol	Name	Explanation
L1/L,L2/N	Main power supply input	Connects single-phase power (Single-phase 200V input).
U, V, W	Inverter output	Connects 3-phase motor.
P1, P(+)	For connection of DC reactor	Connects input power- factor correcting DC reactor (optional).
P(+), N(-)	For DC intermediate circuit	Connected to DC link circuit terminal (for DC bus connection).
G	For inverter grounding	Ground terminal for inverter chassis (case).

Table 2-3-1 Functions of main circuit and ground terminals

1) Main power supply input terminal
Single-phase 200V [L1/L,L2/N]

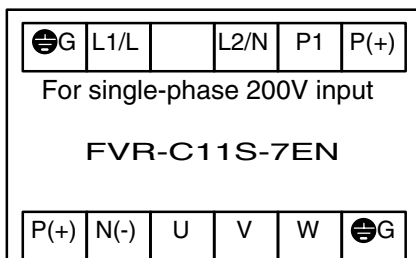

Figure 2-3-1 Arrangement of main circuit and ground terminals

2) Inverter output terminal [U, V, W]

1. Connect these terminals to the 3-phase motor with the correct phase-sequence. If a motor rotation direction does not correspond to the correct rotation direction, exchange any two of the U, V, and W phases.
2. Do not connect a phase-advance capacitor or surge absorber to the inverter output.
3. A very long wiring length between the inverter and the motor causes a high frequency current to flow due to floating capacity between cables, making the inverter trip, increasing the leakage current and deteriorating the accuracy in the current display. To prevent such trouble, the wiring length to the motor should not exceed 50 meters.

When the inverter is operated in the low noise mode (carrier frequency: 8 to 15 kHz) and the wiring length is long, add an optional output circuit filter (OFL filter).

1. Connect the main power supply input terminals to the power supply via a molded case circuit breaker for circuit protection or earth leakage circuit breaker. An earth-leakage circuit breaker which can also detect DC current is recommended. Phase-sequence matching is unnecessary.
2. It is recommended that a magnetic contactor is connected to prevent any failure or accident from becoming serious by disconnecting the inverter from the power supply when the inverter protective function operates.
3. Do not turn on or off the main power supply to start or stop the inverter; instead, use the control circuit terminal FWD/REV or the RUN/STOP key on the keypad panel. If it is unavoidable to turn the main power supply on or off to start or stop the inverter, it must not exceed once per hour.

3) DC reactor connecting terminal [P1, P(+)]

1. Use this terminal to connect a input power-factor correcting DC reactor (optional). Remove the jumper connected in the factory before connecting the DC reactor (see Figure 2-3-2).

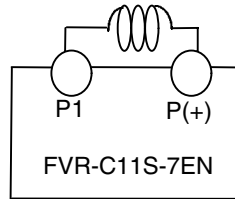

a) Connection diagram

Top of inverter

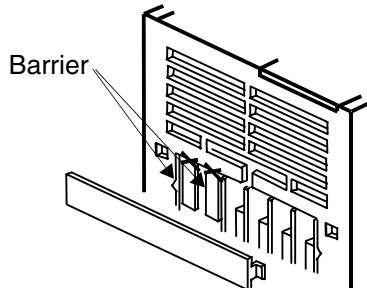

b) Cutting of barrier

Figure 2-3-2 Connection of DC reactor

2. Use diagonal cutting pliers to cut the surface cover barriers from P1, P(+) terminals before connection.
3. If no DC reactor is used, do not remove the jumper.

4) Inverter grounding terminal [⊖G]

Always ground the inverter grounding terminal [⊖G] for safety and noise reduction. Grounding of the metal frames of electric equipment has to be done in accordance with the national and local safety specifications in force.

1. In Japan, the 200V system must be connected to a ground electrode provided with class D grounding, according to the electrical equipment technical standard.

Voltage system	Type of ground-ing work	Grounding resistance
200V	Class D grounding	100 Ω maximum

Table 2-3-2 Grounding of device according to electrical equipment technical standard

2. Connect a thick and short wire to the grounding terminal of the inverter for connection with a ground electrode prepared exclusively for the inverter system.

CAUTION

1. Check that the number of phases and the rated voltage of this product correspond to the number of phases and voltage of the AC power supply.
Otherwise fire could occur.
2. Do not connect the AC power supply to the output terminals (U, V, W).
Otherwise injury could occur.
3. Do not connect a braking resistor directly to the DC terminals P(+), N(-).
Otherwise fire could occur.

2-3-3 Connecting the control terminals

Table 2-3-4 lists the functions of the control circuit terminals.

The method of connecting a control circuit terminal depends on how its function is set.

Connect the control circuit terminals according to the set functions.

- 2) Run/stop command terminal [FWD, REV]
 These terminals are left open in the factory. Pressing the **RUN** key on the keypad panel starts forward operation. When function F02 is set at 0 or 1, the terminal functions are as shown in Table 2-3-3.

1) Digital input terminal

Figure 2-3-3 shows the circuit configuration. Use a reliable contact without poor contact for input.

Example: FUJI control relay HH54PW

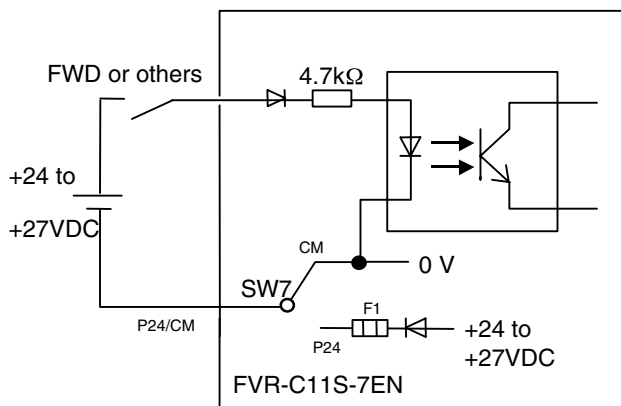

a) When SW7 is set to CM (factory setting)

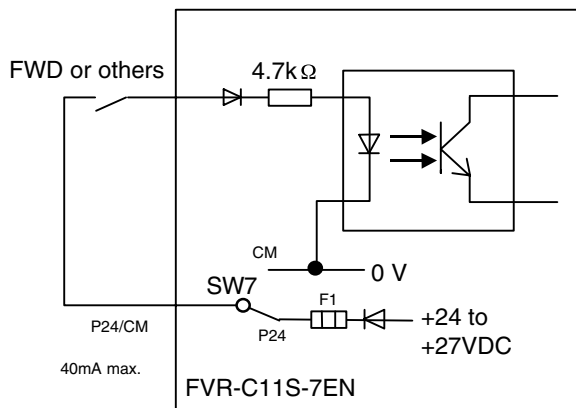

b) When SW7 is set at P24

Figure 2-3-3 Digital input terminal

F02	When SW7 is set at CM	When SW7 is set at P24
0	<p>When +24 to +27 VDC is supplied to FWD - P24/CM, pressing the [RUN] key on the keypad panel starts forward operation.</p> <p>When +24 to +27 VDC is supplied to REV - P24/CM, pressing the [RUN] key on the keypad panel starts reverse operation.</p> <p>When +24 to +27 VDC is supplied to both FWD - P24/CM and REV - P24/CM, the inverter decelerates to stop.</p>	<p>When FWD is short-circuited to P24/CM and the [RUN] key on the keypad panel is pressed, forward operation starts.</p> <p>When REV is short-circuited to P24/CM and the [RUN] key on the keypad panel is pressed, reverse operation starts.</p> <p>When both FWD - P24/CM and REV - P24/CM are short-circuited, the inverter decelerates to stop.</p>
1	<p>When +24 to +27 VDC is supplied to FWD - P24/CM, forward operation starts.</p> <p>When +24 to +27 VDC is supplied to REV - P24/CM, reverse operation starts.</p> <p>When +24 to +27 VDC is supplied to both FWD - P24/CM and REV - P24/CM, the inverter decelerates to stop.</p>	<p>Short-circuit FWD to P24/CM for forward operation, or REV to P24/CM for reverse operation. Short-circuiting both FWD - P24/CM and REV - P24/CM brings the inverter to deceleration and stop.</p>

Table 2-3-3 Description of function F02



CAUTION

In case P24 is short-circuited with 0V by outer circuit when SW7 is set to P24 side, poly switch (F1) turns the power off. To recover the power, open the short circuit and turn the inverter off to allow the temperature to lower.



WARNING

The STOP key is valid only when the function has been set. Prepare another switch for emergency stop. When operation using an external signal terminal is selected, the operation cannot be stopped using the STOP key on the keypad panel.
Otherwise accidents could occur.

- 3) Analog input terminal (13, 12, 11, C1)
 Use these terminals to connect external input analog voltage and analog current and frequency setting device (POT). For connecting a contact to this circuit, use a twin contact for fine current signal.
 Do not use a contact for terminal 11.

***Note the following when wiring:**

1) Surge absorber connection
 When the exciting coil of the magnetic contactor or relay in the control circuit or inverter peripheral circuit is opened or closed, a surge voltage (noise) is generated with a sudden current change. Due to this surge voltage, the inverter control circuit or peripheral equipment may malfunction. If so, directly connect a surge absorber to both ends of the coil. (See Figure 2-3-4).

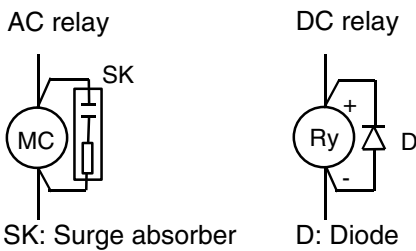

Figure 2-3-4 Surge absorber connection diagram

2) Control circuit wiring

1. Wires connected to control circuit terminals must be 0.5mm² shielded wire or twisted vinyl wire. Remove the sheath as shown in Figure 2-3-5 and then connect it.

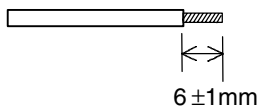

Figure 2-3-5 End treatment

2. Keep the wiring of the main circuit, external relay sequence circuit and control circuit as far away from each other as possible. If they must be adjacent, cross them at right angles.
3. Use a twisted-pair shielded wire for long wiring distances.

3) Shielding sheath connection
 Connect one end of the shielding sheath of a shielded or twisted-pair shielded wire to the ground terminal as shown in Figure 2-3-6. Do not connect the other end.

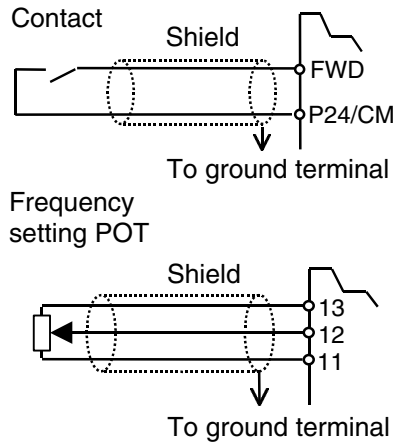

Figure 2-3-6 Connection of sheath of shielded wire



CAUTION

Noise is generated from the inverter, motor, and wiring. Take care that this noise does not cause malfunctions in peripheral sensors and equipment.
Otherwise accidents could occur.

- 4) Control terminal arrangement, screw size, and tightening torque. Screw size: M2.5
Tightening torque: 0.4 Nm

Figure 2-3-7 shows the control terminal block arrangement.

30A	30B	30C	FM	X1	X2	X3	FWD	REV	P24 /CM	11	12	13	C1
-----	-----	-----	----	----	----	----	-----	-----	------------	----	----	----	----

Figure 2-3-7 Control terminal block arrangement

- 5) Remove the plate at the bottom of the surface cover before performing inverter control wiring and reinstall it after the wiring as shown in Figure 2-3-8.

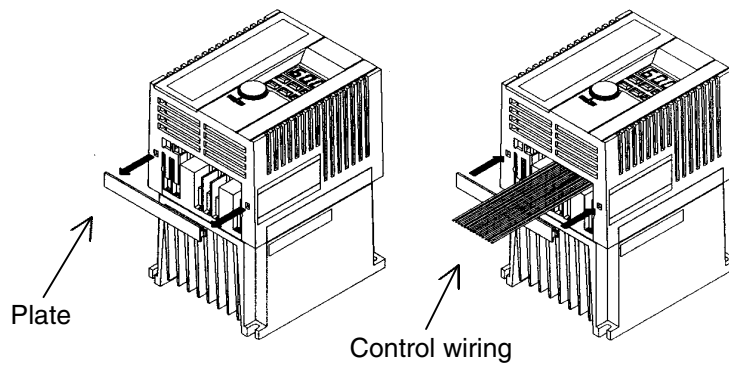

Figure 2-3-8 How to pull out the control wiring

Classification	Terminal symbol	Terminal name	Detailed specifications	Remarks
Analog input	13	Power supply for variable resistor	<ul style="list-style-type: none"> Used as power supply for frequency setting device (POT: 1 to 5 kΩ). (+10VDC 10mADC max.) 	
	12	Frequency setting voltage input	<ul style="list-style-type: none"> 0 to +10VDC/0 to 100%, 0 to +5VDC/0 to 100% (Input impedance : 22 kΩ) 	
	C1	Frequency setting current input	<ul style="list-style-type: none"> 4 to 20mADC/0 to 100% (Input impedance : 250 Ω) 	
	11	Analog common	<ul style="list-style-type: none"> Common terminal for analog input signals 	
Digital input	FWD	Forward operation /Stop command	<ul style="list-style-type: none"> Forward operation with FWD-P24/CM ON and deceleration-stop with FWD-P24/CM OFF (Switch SW7 to P24) 	Deceleration-stop with FWD-P24/CM and REV-P24/CM ON
	REV	Reverse operation /Stop command	<ul style="list-style-type: none"> Reverse operation with REV-P24/CM ON and deceleration-stop with REV-P24/CM OFF (Switch SW7 to P24) 	
	X1	Digital input 1	<ul style="list-style-type: none"> The functions listed below can be set by the X1 to X3 terminal functions. 	Set with functions E01 to E03
	X2	Digital input 2		
	X3	Digital input 3		
	(SS1) (SS2)	Multistep frequency selection	<ul style="list-style-type: none"> Up to four steps speed operation can be selected with SS1 and SS2 ON/OFF signals. 	
	(BX)	Coast to stop command	<ul style="list-style-type: none"> Inverter output is cut immediately and the motor coasts to a stop (no alarm output) if BX goes on. 	
	(RST)	Alarm reset	<ul style="list-style-type: none"> The inverter releases the status held after stop with an alarm when RST changes from ON to OFF. 	
	(THR)	External alarm input	<ul style="list-style-type: none"> The inverter stops with an alarm if THR is set to OFF. 	
	(WE-KP)	Write-enable command for keypad (data change allowed)	<ul style="list-style-type: none"> Data rewriting for each function with the keypad panel is rejected if WE-KP is OFF. Rewriting with keypad panel is allowed if WE-KP is ON. 	

Classification	Terminal symbol	Terminal name	Detailed specifications	Remarks
Digital input	(Hz/PID)	PID control cancel	<ul style="list-style-type: none"> • PID control cancel with Hz/PID ON • PID control with Hz/PID OFF 	
	(LE)	Link operation selection	<ul style="list-style-type: none"> • Operation based on command from RS485 with LE ON • Inverter single operation with LE OFF 	
Output/ Input	P24/CM	Power Supply/ Digital Common	<ul style="list-style-type: none"> • DC Power supply (SW7 set to P24) (+24 to +27 VDC, 40mA max.) • Common terminal for digital input signal (SW7 set to CM) (factory setting) 	Switching of P24/CM terminal with switch SW7
Analog output	FM, 11	Analog monitor	<p>Data selected between the following items is output with DC voltage:</p> <ul style="list-style-type: none"> • Output frequency • PID feedback value • Output current • DC link circuit voltage <p>* Up to two analog voltmeters (input impedance : 10 kΩ) can be connected.</p> <p>Note: Output waveform: An AC pulse is output with consistent frequency and variable duty. The average DC voltage is proportional to output frequency and output current (frequency : 121.6 Hz).</p>	
Contact output	30A 30B 30C	Alarm output for any fault	<p>If the inverter is stopped with an alarm, the non-voltage contact signal (1SPDT) is output (Contact rating: 250V AC, 0.3 A, Power factor = 0.3) (48V DC, 0.5A for Low-voltage Directive or 42V DC, 0.5A for UL/cUL)</p> <p>* Whether an alarm is generated with an exciting operation or non-exciting operation can be switched.</p>	
Optional	DX+ DX-	RS485 communication input/output	<ul style="list-style-type: none"> • Terminal for RS485 communication (when option board is installed) • DX+ : Non-inverted signal, • DX- : Inverted signal 	Installed on optional board.

Table 2-3-4 Functions of control circuit terminals

2-3-4 Connection examples

1) Keypad panel operation

2

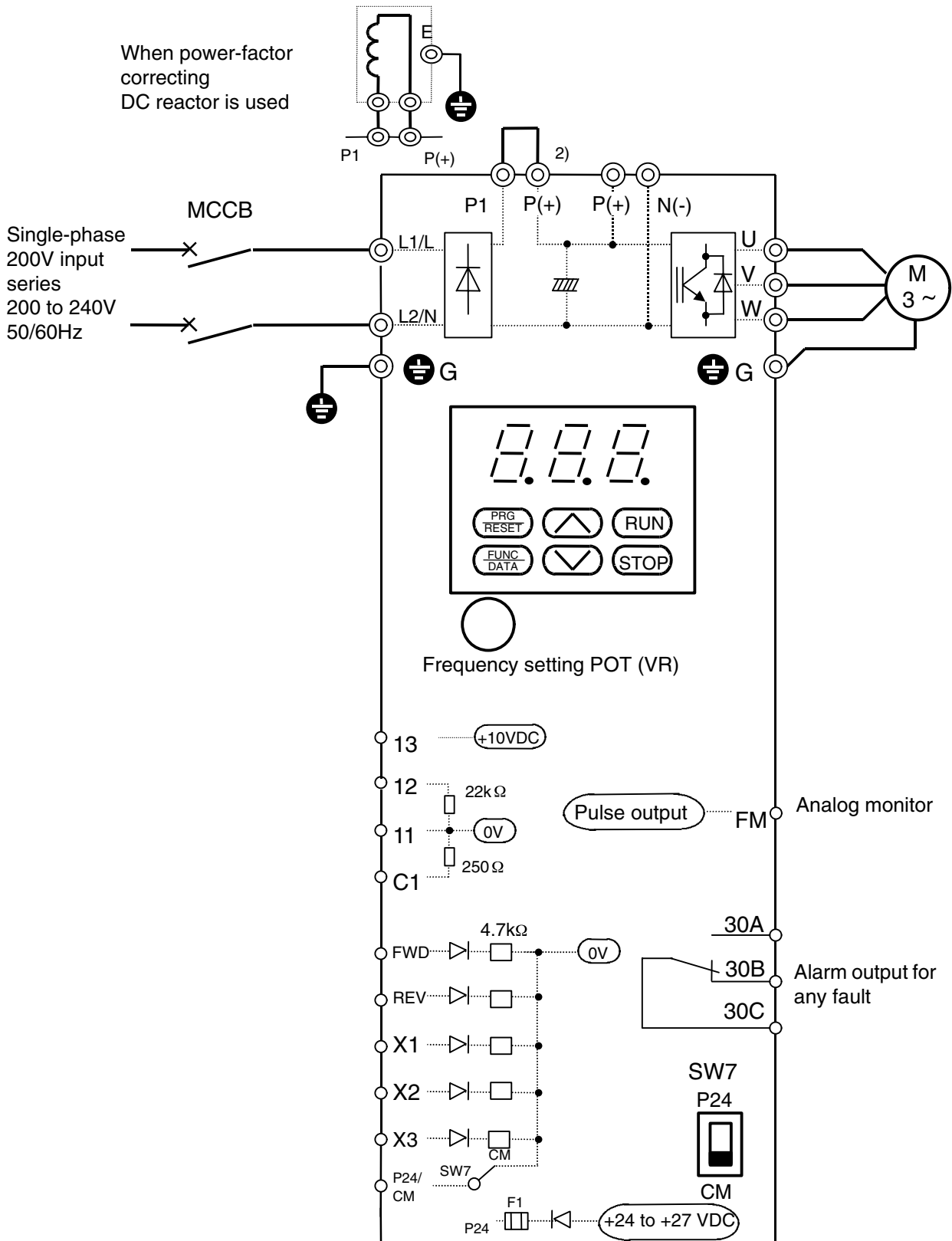

Figure 2-3-9 Wiring diagram of keypad panel operation

- 1) The RUN and STOP keys on the keypad panel can be used to start and stop the operation and the frequency setting POT (VR) can be used to set a frequency only by connecting the power supply and motor with functions set in the factory. Forward rotation is set in the factory.
- 2) Remove the jumper between the P1 and P(+) terminals before connecting the optional power-factor correcting DC reactor.
- 3) Connect the surge absorber in parallel to coils (such as coils of the magnetic contactor and solenoid) near the inverter.

2) External operation
(When external power supply is used)

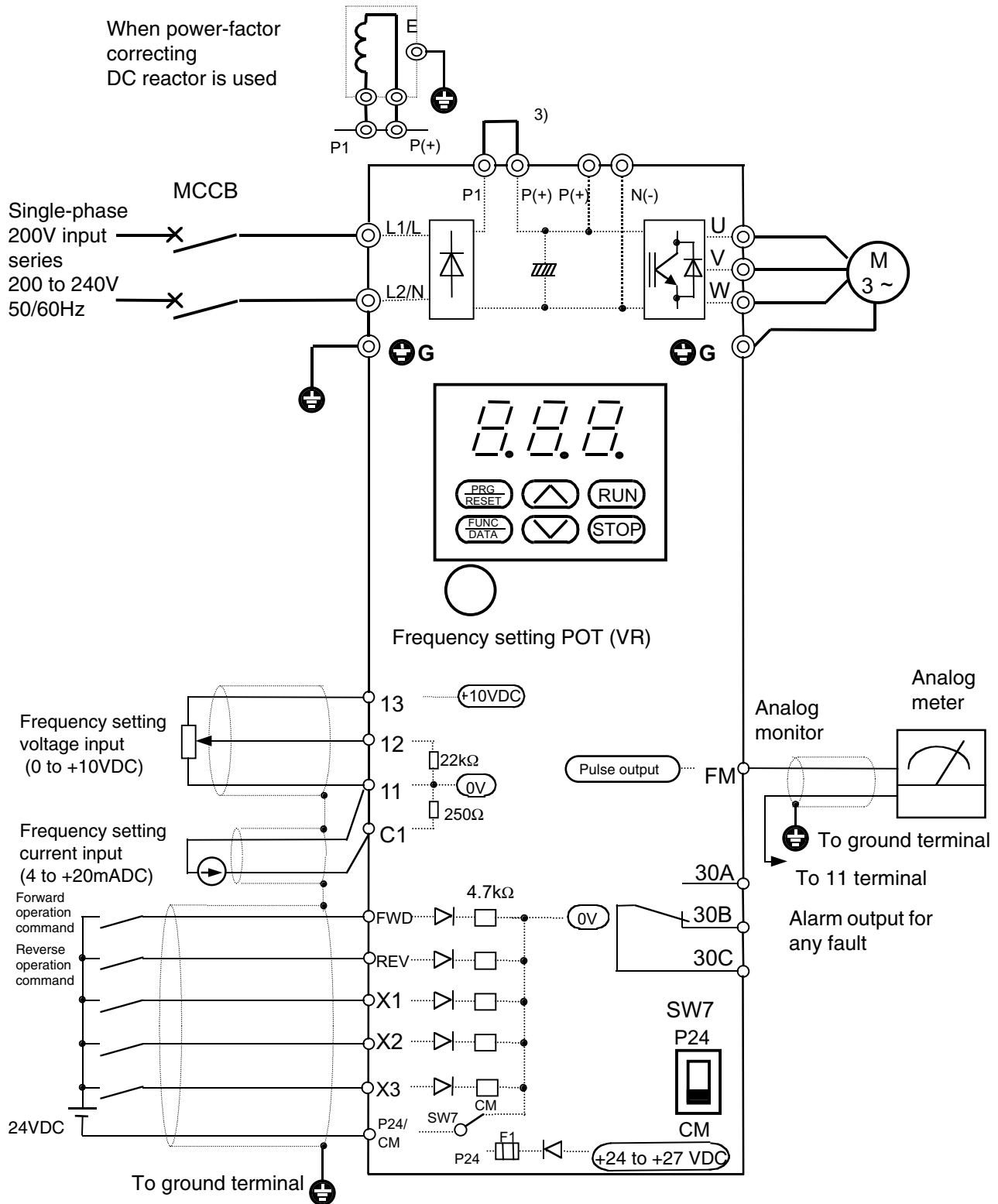

Figure 2-3-10 Wiring diagram of external operation (When external power supply is used)

- 1) Use this connection to start, stop the operation and set the frequency with external signals. 0 to 10V DC can be set while function F01 is set to 1 and +4 to +20mA DC can be set while function F01 is set to 2. Set function F02 to 1.
- 2) Set SW7 at CM
- 3) Remove the jumper between the P1 and P(+) terminals before connecting the optional power-factor correcting DC reactor.
- 4) Connect the surge absorber in parallel to coils (such as coils of the magnetic contactor and solenoid) near the inverter.
- 5) Use twisted or shielded wire as control signal wire. Connect the shield to the ground terminal.

3) External operation
(When internal power supply is used)

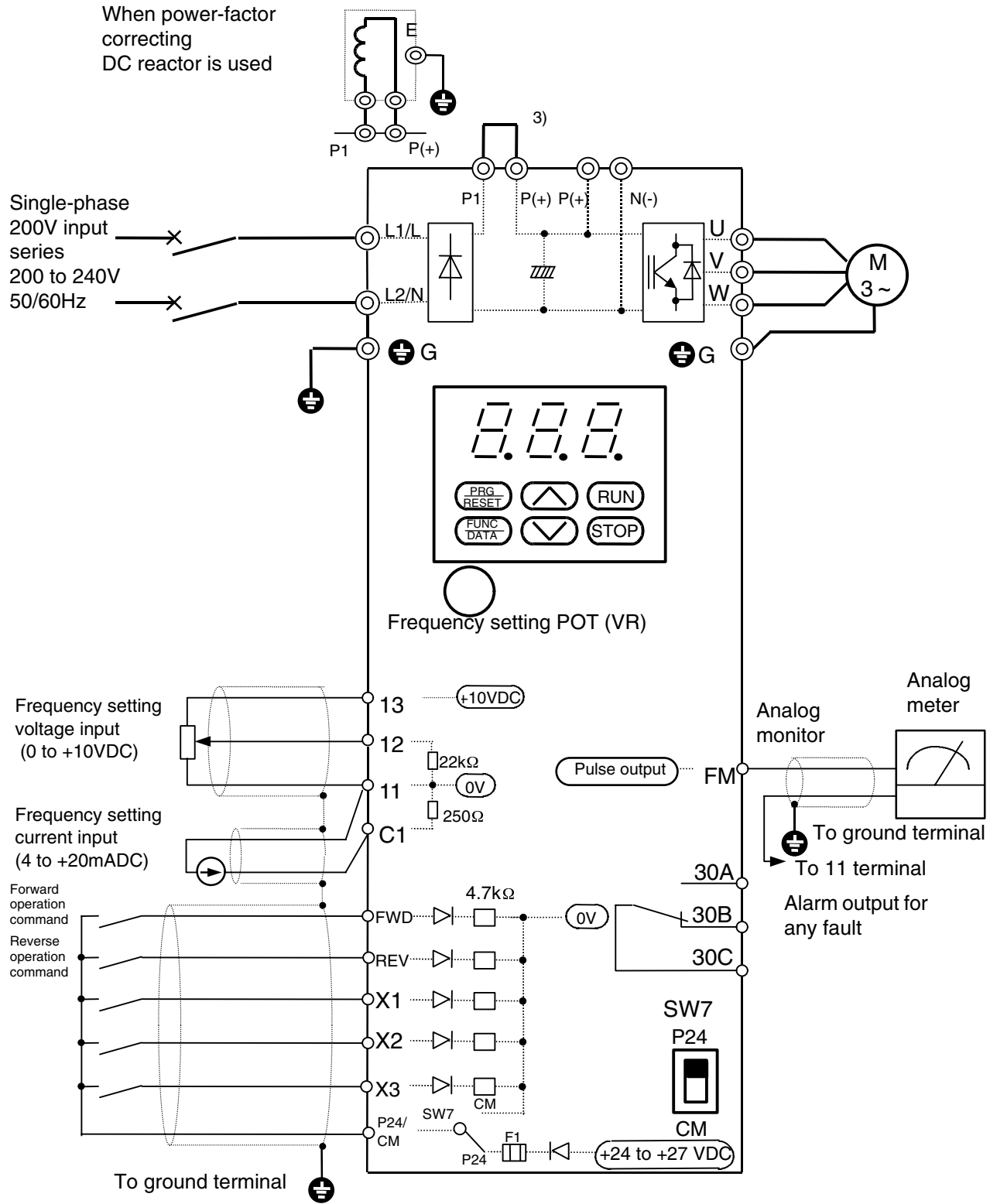

Figure 2-3-11 Wiring diagram of external operation (When internal power supply is used)

- 1) Use this connection to start, stop the operation and set the frequency with external signals. 0 to 10V DC can be set while function F01 is set to 1 and +4 to +20mA DC can be set while function F01 is set to 2. Set function F02 to 1.
- 2) Set SW7 at P24.
- 3) Remove the jumper between the P1 and P(+) terminals before connecting the optional power-factor correcting DC reactor.
- 4) Connect the surge absorber in parallel to coils (such as coils of the magnetic contactor and solenoid) near the inverter.
- 5) Use twisted or shielded wire as control signal wire. Connect the shield to the ground terminal.

4) Connection to PLC
 (When external thermal O/L relay is used)

2

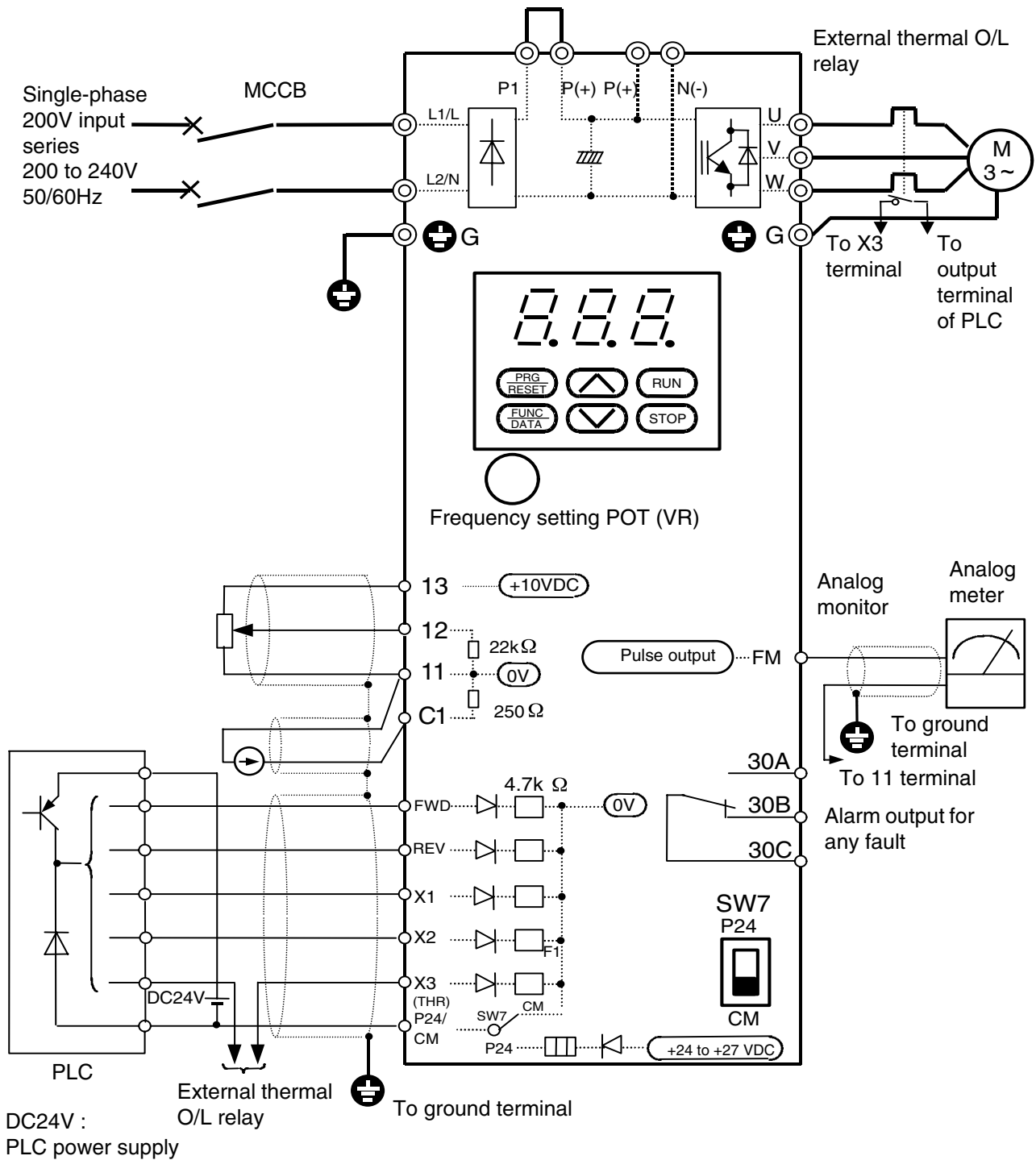

Figure 2-3-12 Connection example of PLC terminal (using THR function terminal)

- 1) Set SW7 at CM.
- 2) In the figure above, the power is supplied to the external thermal relay from the power supply of the PLC. If the power supply of the PLC is turned off while the inverter remains turned on, OH2 trips.
- 3) To prevent OH2 from tripping upon shutdown of the PLC, deselect the THR terminal function and use the electronic relay of the inverter.

**CAUTION**

When SW7 is set at P24, possibly causing inner parts to damage.

5) Connection to PLC (When analog signal is input from PLC)

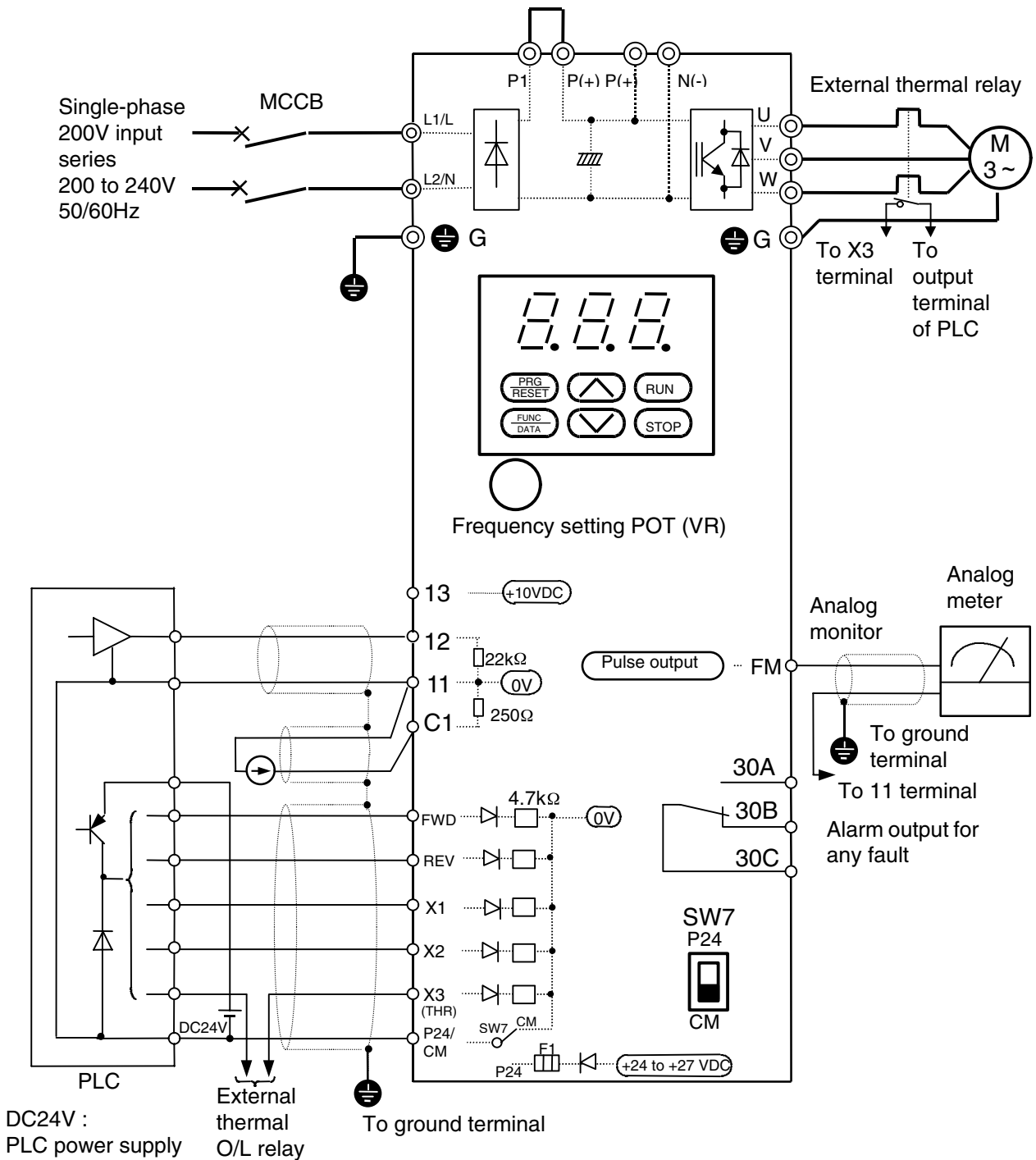

Figure 2-3-13 Connection example of PLC terminal (when analog signal is input from PLC)

- 1) Set SW7 at CM.
- 2) With this connection, the power is supplied from the PLC power supply to the external thermal O/L relay. So, OH2 trip is activated by PLC power-off with the inverter turned on.
- 3) To prevent inverter trip with OH2 when the PLC power being turned off, do not select the THR terminal function and use the inverter electronic thermal O/L relay.



When SW7 is set at P24, poly switch (F1) activates a current limit to turn the power off.

2-4 Others

2-4-1 Harmonic component

A harmonic component which may influence the phase-advance capacitor and generator is included in the inverter input current. If necessary, connect a power-factor correcting DC reactor (DCR) (option) for the inverter.

2-4-2 Noise

When noise generated from the inverter may affect peripheral equipment, and noise generated from peripheral equipment may malfunction the inverter, the following basic countermeasures should be taken.

- 1) When noise affects other devices via power and ground wires
 - Separate the ground of the inverter and that of the affected device.
 - Connect a noise filter to the inverter power wire.
 - Use an isolation transformer to separate the power supply of the inverter and that of the affected device.

- 2) When another device is affected by induction or radiation
 - Separate the main circuit wiring of the inverter from the control wiring and wiring of the affected device.
 - Encase the inverter main circuit wiring in a metal tube and ground the metal tube near the inverter.
 - Encase the inverter in a metal rack and ground the rack.
 - Connect a noise filter to the inverter power wire.

- 3) When noise generated from peripheral equipment affects the inverter
 - Use twisted or twisted-pair shielded wires for the inverter control wiring. Ground the shields.
 - Connect a surge absorber in parallel to the coil of the magnetic contactor and solenoid.
 - If the power supply includes much distortion of the waveform or surge, connect an impedance matching AC reactor for coordination of power supply.

2-4-3 Leakage current

Leakage current flows through the inverter I-O wiring and motor stray capacitance when the inverter transistor is turned on and off.

Table 2-3-3 lists the countermeasures for the problems caused by the leakage current.

	Problem	Countermeasures
1	Trip of earth leakage circuit breaker on main power supply side	<ol style="list-style-type: none"> 1. Set the carrier frequency lower. 2. Shorten the wiring between the inverter and motor. 3. Increase the ELCB/RCD sensitivity current. 4. Replace the ELCB/RCD with an ELCB/RCD that is designed for high frequencies.
2	Trip of external thermal O/L relay	<ol style="list-style-type: none"> 1. Set the carrier frequency lower. 2. Increase the thermal O/L relay set value. 3. Use the inverter electronic thermal O/L relay.

Table 2-3-3 Countermeasures for leakage current

3 Operation

3-1 Inspection and Preparation before Operation

Check the following before operation:

- 1) Check whether the connection is correct.
For single-phase 200V series, check whether the power supply is connected correctly to the L1/L and L2/N terminals. Also check whether the inverter grounding terminal G is securely connected.
- 2) Check for short-circuits and ground faults between terminals and between live parts.
- 3) Check for loose terminals, connectors, and screws.
- 4) Check whether the motor is separated from mechanical equipment.
- 5) Set switches to OFF before turning on the power so that the inverter will not start or operate abnormally at power-on.
- 6) Check the following after power-on:
 - a) Check for alarms displayed on the keypad panel.



WARNING

1. Always install the surface cover before turning on the power. Do not remove the surface cover during conduction. **Otherwise electric shock could occur.**
2. Do not operate a switch with wet hands. **Otherwise electric shock could occur.**

3-2 Operation Method

There are various operation methods. Select a method depending on the purpose and operation specifications with reference to Chapters 4 and 5. Table 3-2-1 lists operation methods used generally.

Operation method	Frequency setting	Running command
Operation by using keypad panel	Built-in frequency setting POT (VR) or UP/DOWN key	RUN/STOP key
Operation by using external signal terminal	Setting by using analog voltage, analog current, and external POT (VR)	Contact input (switch) <ul style="list-style-type: none"> • When SW7 is set at CM Connect external power supply and connect terminal FWD with the (+) terminal of the external power supply, or connect terminal REV with the (+) terminal of the external power supply. • When SW7 is set at P24 Connect terminal FWD with P24/CM or connect terminal REV with P24/CM. Refer to section 2-3-3.

Table 3-2-1 General operation method

3-3 Trial Run

The motor rotates when a frequency value and running command are input from the keypad panel or external signal terminal.

Refer to Table 3-3-1.

Use a low frequency (about 5Hz) for trial runs.

A frequency can be set using the built-in frequency setting POT (VR) , and forward/stop can be performed using the keypad panel with the functions set in the factory.

Operation method	Frequency setting	Running command
Operation by using keypad panel	(When built-in POT (VR) is used) The frequency increases when the variable resistor is turned clockwise and reduces when it is turned counterclockwise. The motor accelerates when the variable resistor is turned clockwise during operation and decelerates when it is turned counterclockwise.	Operation starts when the RUN key is pressed. The motor decelerates and stops when the STOP key is pressed.
Operation by using external signal terminal	(When the UP/DOWN key is used) Frequency increases when the UP key is pressed. It reduces when the DOWN key is pressed.	<ul style="list-style-type: none"> • When SW7 is set at CM Connect external power supply and turn FWD (REV) on to start. Turn it off to bring the inverter to deceleration and stop. • When SW7 is set at P24 Turn FWD (REV) on to start. Turn it off to bring the inverter to deceleration and stop. <p>Operation is not stopped although the STOP key is pressed. Refer to section 2-3-3.</p>

Table 3-3-1 Running command

Check the following items:

- a) Rotation direction
- b) Whether rotation is smooth (whether there is a motor buzzing noise or abnormal vibration)
- c) Whether acceleration and deceleration are smooth
- d) Whether the inverter cooling fan is rotating (1.5kW or more)

3

If no abnormality is detected, check the item again by increasing the frequency.

Even if the output from the inverter is stopped, you will get an electric shock when you touch the main circuit terminals such as inverter output terminals U, V and W if the voltage is supplied to the main power supply input terminal.

The smoothing capacitor in the inverter has been charged when the power is turned off and it is not discharged immediately. Before touching the electric circuit, wait until at least five minutes have elapsed after power-off and the charge lamp is off, indicating the voltage is already low.

After checking normality in the above trial run, start operation.



WARNING

1. The STOP key is valid only when the function has been set.
Assign another switch to emergency stops.
Otherwise accidents could occur.
2. Operation starts suddenly if alarm reset is done with an running signal input. Check that no running signal is input before alarm reset.
Otherwise accidents could occur.



CAUTION

Do not touch the heat sink.
Otherwise burns could occur.

4 Keypad Panel

4-1 Names and Functions

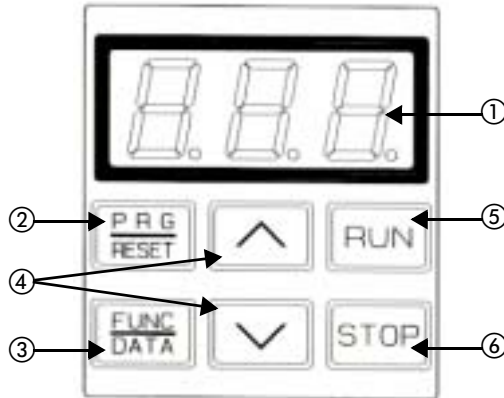

- ① Digital display
In program mode: Shows function codes and data codes.
In Operation mode: Shows the output frequency and output current, etc.
In Trip mode: Shows a code indicating the causes of the trip.
- ② Program (Reset) key
Switches between Operation mode and Program mode.
In Trip mode: Resets the trip status and change to Operation mode.
- ③ Function/Data key
In Operation mode: Switches between frequency display and output current display during stopped and running. In Program mode: Used to read and write various function codes and function data items.
- ④ Up/down keys
In Operation mode: Used to increase and reduce the frequency (motor speed). In Program mode: Used to change a function code and data value.
- ⑤ RUN key
This key is used to start operation.
The LED is on during operation.
This key does not function when the data code from the external signal (digital input) is selected (F02 = 1).
- ⑥ STOP key
This key is used to stop operation.
This key does not function when the data code from the external signal (digital input) is selected (F02 = 1).

4-2 Operating Keypad Panel

- 1) Switching monitor
The display can be switched between frequency display and output current display by pressing the **FUNC DATA** in Operation mode.

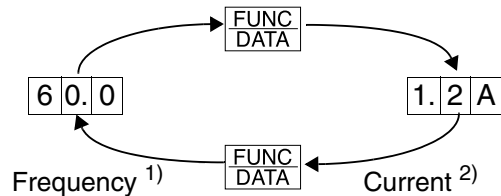

- 1) Frequency is displayed as a percentage with the least significant digit in PID control operation (function H20 is set to 1 or 2):

10.0 for 10%

100 for 100%

- 2) The reference frequency is displayed when the **▲ ▼** key is pressed in current indication.

- 2) Stopping operation

Operation is started when the **RUN** is pressed, and is stopped when the **STOP** is pressed while function **F02** is set to a value other than **1**.

The rotation direction is:

F02 = 0: Forward rotation with FWD-P24/CM ON, and reverse rotation with REV-P24/CM ON

F02 = 2: Forward rotation (FWD/REV input is ignored.)

F02 = 3: Reverse rotation (FWD/REV input is ignored.)

3) Changing frequency

The frequency increases when the Δ is pressed and decreases when the ∇ is pressed while function $F 0 1$ is set to $\square \square 0$.

The change speed is increased when the FUNC DATA is pressed at the same time as the Δ or ∇ .

Note: Do not turn the power off for five seconds after monitor switching or function setting, to prevent Er1 occurrence.

4) Setting function

	Procedure	Display
1	Press the PRG RESET key to set the program mode.	$6 0.0$ $F 0 0$
2	Press the $\Delta \nabla$ key to select a function.	$F 0 1$ ¹⁾
3	Press the FUNC DATA key to display data.	$\square \square 1$
4	Press the $\Delta \nabla$ key to change the data.	$\square \square 2$
5	Press the FUNC DATA to save the data.	$F 0 2$
6	Changing another function Press the PRG RESET to cancel the program mode.	$6 0.0$

1) The function code display changes as shown below.

The $0 0 1$ to $0 1 1$ are displayed only with $0 0 0$ set to $\square \square 1$.

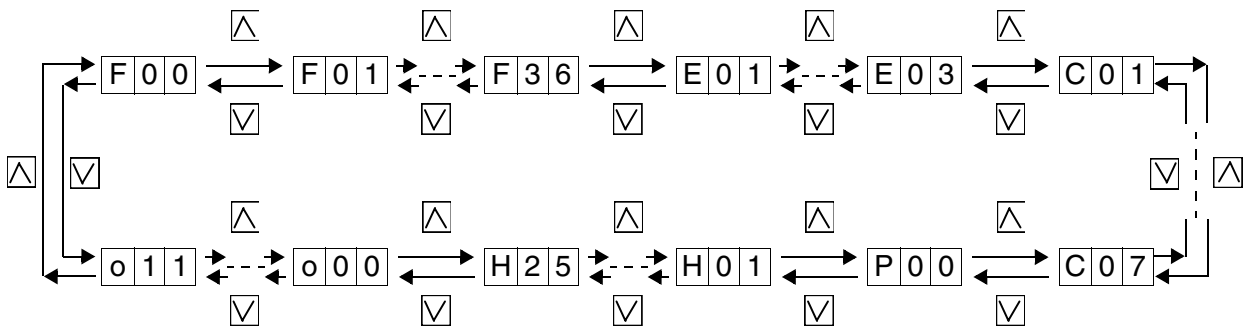

5 Selecting Function

5-1 Function Selection List

F: Fundamental functions

Function code No.	Name	Setting range	Unit	Min. unit	Factory setting	Change during operation	User setting
F00	Data protection	0: Data change enabled, 1: Data protected	-	-	0	X	
F01	Frequency command	0: Key operation (<input type="checkbox"/> , <input checked="" type="checkbox"/> key) 1: Voltage input (terminal [12]) (0 to +10VDC) 2: Current input (terminal[C1]) (4 to 20mADC) 3: Voltage input + current input (terminals[12]+[C1]) 4: Analog (VR built in inverter)	-	-	4	X	
F02	Operation method	0: Key operation (rotation direction: By terminal block) 1: External signal (digital input) 2: Key operation (forward rotation) 3: Key operation (reverse rotation)	-	-	2	X	
F03	Maximum output frequency	50 to 120Hz	Hz	1	50	X	
F04	Base frequency	25 to 120Hz	Hz	1	50	X	
F05	-	Data cannot be changed.	-	-	0	-	
F06					0		
F07	Acceleration time	0.0 to 60.0s 0.01 second is set when 0.0 is specified.	s	0.1	6.0	○	
F08	Deceleration time	0.1 to 60.0s	s	0.1	6.0	○	
F09	Torque boost	0,1 : Variable torque characteristic 2 to 31: Constant torque characteristic	-	1	13	○	

Change during operation: X = impossible, = possible (enabled by using), = possible (enabled by using)

Function code No.	Name	Setting range	Unit	Min. unit	Factory setting	Change during operation	User setting
F10	Electronic thermal overload relay for motor (Select)	0: Inactive 1: Active (for 4-pole standard motor) 2: Active (for 4-pole FUJI inverter motor)	-	-	1	△	
F11	(Level)	20 to 135% of inverter rated current	A	0.01	Typical value of FUJI 4-pole motor	△	
F12	(Thermal time constant)	0.5 to 10.0min	min	0.1	5.0	△	
F14	Restart after momentary power failure (Select)	0: Inactive (Trip and alarm when power failure occurs) 1: Inactive (Trip and alarm when power recovers) 2: Active (Momentarily stops and restarts at setting frequency of before power failure) 3: Active (Momentarily stops and restarts at starting frequency)	-	-	0	X	
F15	Frequency limiter (High)	0 to 120Hz	Hz	1	70	○	
F16	(Low)	0 to 120Hz			0	○	
F17	Gain (for frequency setting signal)	0: For 0 to 10VDC (4 to 20 mA DC) 1: For 0 to 5VDC (4 to 12 mA DC)	-	-	0	X	
F18	Bias frequency	-120 to 120Hz	Hz	1	0	○	
F20	DC injection brake (Starting freq.)	Fixed to 3Hz	Hz	-	3.0	-	
F21	(Level)	0 to 100%	%	1	50	○	
F22	(Braking time)	0.0 s (Inactive), 0.1 to 30.0 s	s	0.1	0.0	○	
F23	Starting frequency	1 to 6Hz	Hz	1	1	X	
F24	-	Data cannot be changed.	-	-	0.0	-	
F25	Stop frequency	1 to 6Hz	Hz	1	1	X	

Change during operation: X = impossible, △ = possible (enabled by using FUNC DATA), ○ = possible (enabled by using △ ▽)

Function code No.	Name	Setting range	Unit	Min. unit	Factory setting	Change during operation	User setting
F26	Motor sound (carrier freq.)	0 to 15kHz 0.75kHz is set when 0 is specified	kHz	1	15	○	
F27	(sound tone)	0: Level 0 1: Level 1 2: Level 2 3: Level 3	-	-	0	○	
F30	FM terminal (Voltage adjust)	0 to 200%	%	1	100	○	
F31	(Function)	0: Output frequency 1: Output current 2: PID feedback amount 3: DC link circuit voltage	-	-	0	△	
F36	30Ry operation mode	0: Excited when tripped 1: Normally excited	-	-	0	X	

5

E: Extension Terminal Functions

Function code No.	Name	Setting range	Unit	Min. unit	Factory setting	Change during operation	User setting
E01	X1 terminal (function selection)	Use the code values listed below to select [X1], [X2] and [X3] terminal functions.	-	-	0	X	
E02			-	-	2	X	
E03	X2 terminal (function selection) X3 terminal (function selection)		-	-	3	X	
		0: Multistep frequency 1 (SS1) 1: Multistep frequency 2 (SS2) 2: Coast-to-stop command (BX) 3: Alarm reset (RST) 4: External alarm (THR) 5: Write enable command for keypad (WE-KP) 6: PID control cancel (Hz/PID) 7: Link operation selection (LE)					

Change during operation: X = impossible, △ = possible (enabled by using FUNC DATA), ○ = possible (enabled by using △ ▽)

C: Control Functions of Frequency

Function code No.	Name	Setting range	Unit	Min. unit	Factory setting	Change during operation	User setting
C01	Jump frequency1 2 3 (Hysteresis)	0 to 120Hz	Hz	1	0	○	
C02				1	0	○	
C03				1	0	○	
C04		0 to 30Hz	Hz	1	3	○	
C05	Multistep frequency 1 2 3	0.0 to 120Hz	Hz	0.1	0.0	○	
C06				0.1	0.0	○	
C07				0.1	0.0	○	

5

P: Motor Parameters

Function code No.	Name	Setting range	Unit	Min. unit	Factory setting	Change during operation	User setting
P00	Motor characteristics	0 to 10	-	-	2	○	

H: High Performance Functions

Function code No.	Name	Setting range	Unit	Min. unit	Factory setting	Change during operation	User setting
H01	Operation time	Operation time accumulation	100 Hr	1	0	-	
H02	Trip history	The contents of the last four alarms are displayed sequentially.	-	-	---	-	
H03	Data initialization	1: Initialized (return to factory setting value)	-	-	0	X	

Change during operation: X = impossible, △ = possible (enabled by using FUNC DATA), ○ = possible (enabled by using △ ▽)

Function code No.	Name	Setting range	Unit	Min. unit	Factory setting	Change during operation	User setting
H04	Retry (count)	0: No retry 1: Retry (Count is fixed to 5.)	-	-	0	△	
H06	Cooling fan on/off control	0: Inactive 1: Active	-	-	0	△	
H20	PID control (Mode select)	0: Inactive 1: Active (forward operation) 2: Active (reverse operation)	-	-	0	X	
H21	(Feedback signal select)	0: Terminal [12] (0 to +10VDC) Input 1: Terminal [C1] (4 to 20mADC)Input 2: Terminal [12] (+1 to +5VDC) Input	-	-	1	X	
H22	(P-gain)	0.01 to 10.0 times (1to1000%)	-	0.01	0.01	○	
H23	(I-gain)	0.0s : Inactive 0.1 to 999s	s	0.1	0.0	○	
H24	(D-gain)	0.00s : Inactive 0.01 to 10.0s	s	0.01	0.00	○	
H25	(Feedback filter)	0.0 to 60.0s	s	0.1	0.5	○	

O: Optional Functions

Function code No.	Name	Setting range	Unit	Min. unit	Factory setting	Change during operation	User setting
o00	Option selection (RS485 communication)	0: Option inactive 1: Option active Set 0 when the optional RS485 communication unit is not used.	-	-	0	△	
o01	Station address	1 to 31	-	-	1	△	

Change during operation: X = impossible, △ = possible (enabled by using FUNC DATA), ○ = possible (enabled by using △ ▽)

Function code No.	Name	Setting range	Unit	Min. unit	Factory setting	Change during operation	User setting
o02	Selection of operation in error occurrence	0: Er8 trip with eight continuous communication errors or check sum errors 1: Er8 trip after the time (o03) set in the timer elapses with eight continuous communication errors or check sum errors 2: Er8 trip if communication does not recover until the time (o03) set in the timer elapses 3: Retry and operation continuation with communication or check sum error	-	-	0	△	
o03	Selection of time set in timer	1 to 60s	s	1	2	△	
o04	Transmission rate	0: 19200bps 1: 9600bps 2: 4800bps 3: 2400bps 4: 1200bps	-	-	1	△	
o05	Data length selection	0:8bits 1:7bits	-	-	0	△	
o06	Parity bit selection	0: No parity 1: Even parity 2: Odd parity	-	-	0	△	
o07	Stop bit selection	0:2bits 1:1bit	-	-	0	△	
o08	Communication discontinuation detection time	0: No detection, 1 to 60s	s	1	0	△	
o09	Response interval	0.00 to 1.00	s	0.01	0.01	v	
o10	RS485 command selection (frequency setting)	0: Selection of frequency setting selected with F01 1: Selection of frequency setting from RS485	-	-	0	X	
o11	RS485 command selection (operation command)	0: Selection of operation command selected with F02 1: Selection of operation command from RS485	-	-	0	X	

Table 5-1-1 Table of Function Selection List

Note: For details on "o01" to "o11", refer to the instruction manual that came with the optional RS485 serial communication unit.

Change during operation: X = impossible, △ = possible (enabled by using FUNC DATA), ○ = possible (enabled by using △ ▽)

5-2 Details of Each Function

F00 Data protection

Factory setting	Change during operation
0	X

Set data can be locked to prevent it from being changed by mistake when using the keypad panel:

0 Data can be changed.

1 Data is protected.

Data is changed when the STOP + Δ or ∇ key are pressed simultaneously.

F01 Frequency command

Factory setting	Change during operation
4	X

The following five values can be selected:

0 Key operation [Δ ∇ key]

1 Voltage input (terminal 12) (0 to + 10VDC)

2 Current input (terminal C1) (4 to 20mADC)

3 Voltage input (terminal 12) + current input (terminal C1)

4 Analog setting (POT built in inverter)



CAUTION

High-speed operation can be set by the inverter easily. Carefully check the limit of the motor and machine before changing the setting.

Otherwise injuries could occur.

F02 Operation method

Factory setting	Change during operation
2	X

The following four values can be selected: refer to Table 2-3-3.

0 Key operation [RUN STOP key]

The motor runs when the RUN key is pressed and decelerates to stop when the STOP key is pressed. The direction of rotation depends on the FWD and REV terminals as follows.

When the external power supply is used (Set SW7 at CM.)

+24 to +27 VDC

supplied to FWD - P24/CM: Forward

+24 to +27 VDC

supplied to REV - P24/CM: Reverse

Operation is impossible when

+24 to +27 VDC is supplied to both or none of FWD - P24/CM and REV - P24/CM.

When the internal power supply is used (Set SW7 at P24.)

FWD - P24/CM short-circuited: Forward

REV - P24/CM short-circuited: Reverse

Operation is impossible when both the FWD and REV terminals or none of them are short-circuited with the P24/CM terminal.

Change during operation: X = impossible, Δ = possible (enabled by using FUNC DATA), ○ = possible (enabled by using Δ ∇)

1 External signal operation (Digital input) (FWD, REV)

When the external power supply is used (Set SW7 at CM):

Forward operation with +24 to +27 VDC supplied to FWD - P24/CM and deceleration to stop with them open.

Reverse operation with +24 to +27 VDC supplied to REV - P24/CM and deceleration to stop with them open.

No operation with +24 to +27 VDC supplied to both FWD - P24/CM and REV - P24/CM.

When the internal power supply is used (Set SW7 at P24):

Forward operation with FWD - P24/CM short-circuited and deceleration to stop with them open.

Reverse operation with REV - P24/CM short-circuited and deceleration to stop with them open.

No operation with both FWD - CM and REV - CM short-circuited.

F03 Maximum output frequency

Factory setting	Change during operation
50Hz	X

This function sets the maximum output frequency.

5 0

to

1 2 0

The maximum output frequency can be set with a resolution of 1 Hz in a range between 50 and 120 Hz.

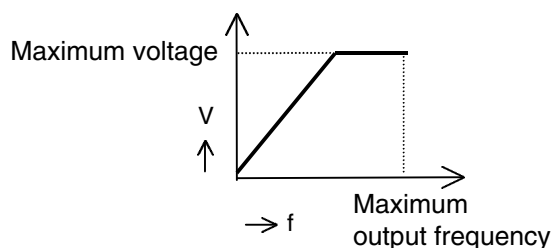

2 Keypad operation (forward rotation) [RUN STOP key]

The motor runs forward when the RUN key is pressed and decelerates-to-stop when the STOP key is pressed. FWD and REV terminal input is ignored.

3 Keypad operation (reverse rotation) [RUN STOP key]

The motor runs in reverse when the RUN key is pressed and decelerates-to-stop when the STOP key is pressed. FWD and REV terminal input is ignored.



CAUTION

High-speed operation can be set by the inverter easily. Carefully check the limit of the motor and machine before changing the setting.

Otherwise injuries could occur.

Note: This function can be changed only while the FWD and REV terminals are open.

Change during operation: X = impossible, Δ = possible (enabled by using FUNC DATA), \bigcirc = possible (enabled by using)

F04 Base frequency

Factory setting	Change during operation
50Hz	X

This function sets a base frequency (branch point between constant torque characteristic and constant output characteristic).

2	5
---	---

 to

1	2	0
---	---	---

The base frequency can be set with a resolution of 1 Hz in a range between 25 and 120 Hz..

Set a frequency matching the motor characteristics.
 A value exceeding the maximum frequency can be set but the output voltage is reduced.

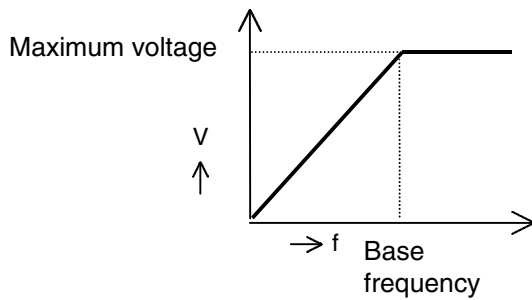

F05
F06

Factory setting	Change during operation
0	X

Data cannot be changed.

F07 Acceleration time

Factory setting	Change during operation
6.0s	○

0	0
---	---

 to

6	0	0
---	---	---

The time taken to increase from 0.0 Hz to the maximum output frequency can be set in an increment of 0.1 s step in a range between 0.0 and 60.0 s.

0.01 is set when 0.0 is specified.

F08 Deceleration time

Factory setting	Change during operation
6.0s	○

0	1
---	---

 to

6	0	0
---	---	---

The time taken to increase from the maximum output frequency to 0.0 Hz can be set in a range between 0.1 and 60.0 s. (In an increment of 0.1 s step)



Change during operation: X = impossible, Δ = possible (enabled by using

FUNC DATA

), ○ = possible (enabled by using

△	☑
---	---

)

F09 Torque boost

Factory setting	Change during operation
13	○

This function can choose between 32 types of boost according to the load type and motor characteristics.

- 0 } For square law torque loads (fan, pump)
- 1 } For square law torque loads (fan, pump)
- 2 } Lower
- to } ↓
- 3 1 } Higher

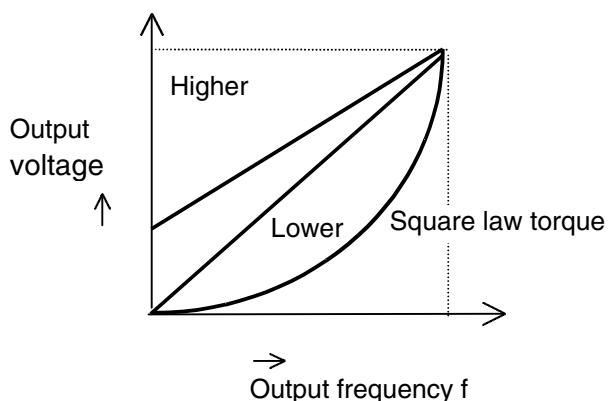

Set □□8 when using a FUJI inverter motor (FV motor).

F10 Electronic thermal O/L relay (Select)

Factory setting	Change during operation
1	△

This function is used to select between the following three values:

- 0 Inactive
- 1 Active 4-pole standard motor
- 2 Operation (inverter motor) ... 4-pole FUJI inverter motor

F11 Electronic thermal O/L relay (Level)

Factory setting	Change during operation
Motor rated current	△

This function sets the operation level of an electronic thermal O/L relay by using an ampere value according to the motor rated current. 20 to 135% of the inverter rated current can be set. Values less than 9.99A can be set in 0.01A step and values more than 10.0A can be set in 0.1A step.

- 0.1 4
- to
- 2.2. 3

Set the value obtained by multiplying the motor rated current by coefficient K in the table below according to the wiring length between the inverter and motor.

Inverter capacity	Wiring length				
	0m	40m	50m	100m	200m
0.1C11S-7EN	K=1.2	External thermal is recommended.			
0.2C11S-7EN	K=1	K=1.1	K=1.2		
0.4C11S-7EN	K=1		K=1.1		
0.75C11S-7EN to 2.2C11S-7EN	K=1				

Change during operation: X = impossible, △ = possible (enabled by using FUNC DATA), ○ = possible (enabled by using △ ▽)

F12 Electronic thermal O/L relay (thermal time constant)

Factory setting	Change during operation
5.0min	△

0.5 to 10.0 } This function sets the operating time of the electronic thermal O/L relay when the current that is 150% of the operation level flows. 0.5 to 10.0 min. can be set (in 0.1 min. step).

The figure below shows the continuous permissible current with F10 (electronic thermal O/L relay [Select]) = 1.

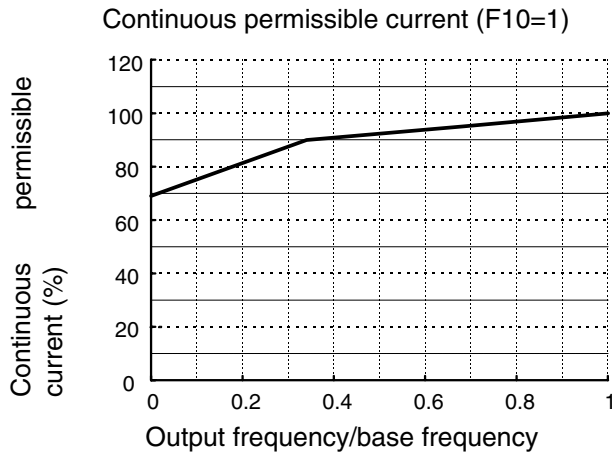

The figure below shows the continuous permissible current with F10 (electronic thermal O/L relay [Select]) = 2. 100% of the continuous permissible current is the current value set with function F11 (electronic thermal O/L relay [Level]).

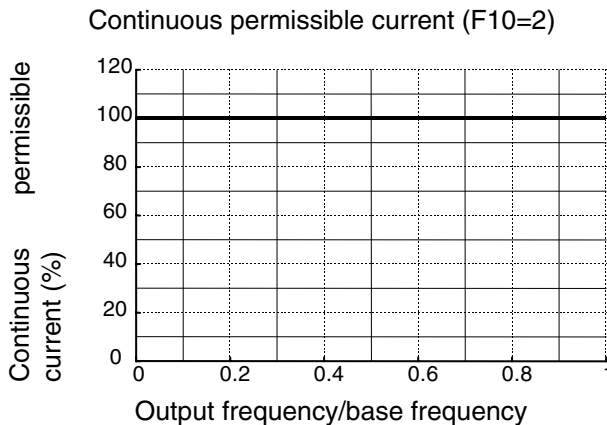

The graph below shows the electronic thermal O/L relay operating characteristics. Output current values for the electronic thermal operating levels (values set with function F11) are plotted horizontally and operating times for output current are plotted vertically.

This graph is for F10 = 1 with the base frequency of 50Hz. The characteristics for output frequencies exceeding the base frequency are the same as the characteristics for the base frequency. When function F10 is set to 2, the characteristics are always the same as those for the base frequency. The operating time with output current of 150% can be adjusted by using function F12 (electronic thermal O/L relay (thermal time constant)).

Operating time characteristics

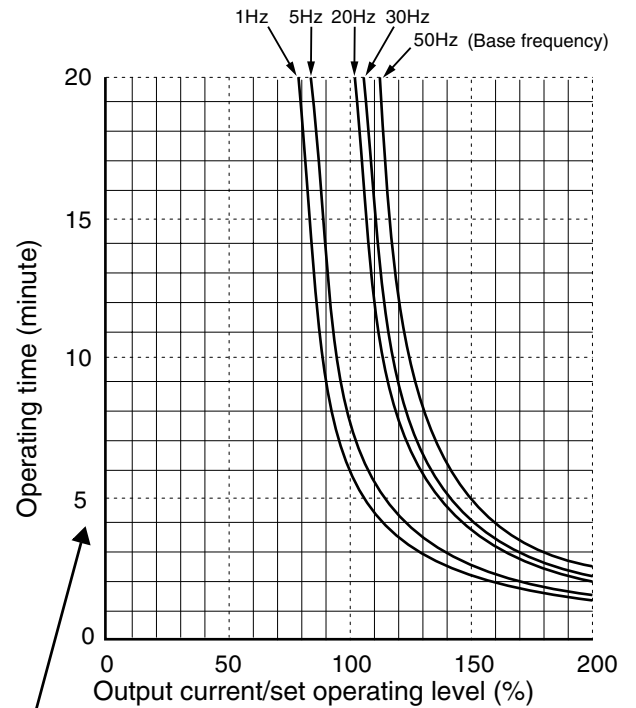

Change during operation: X = impossible, △ = possible (enabled by using FUNC DATA), ○ = possible (enabled by using)

F14 Restart after momentary power failure (Select)

Factory setting	Change during operation
0	X

This function determines whether operation is restarted upon recovery from momentary power failure:

0 Inactive

Failure while inverter is stopped:
The stop status is continued after recovery from the failure.
Failure during operation:
LU indication is held immediately due to undervoltage and the inverter trips with alarm output.

1 Inactive

Failure while inverter is stopped:
The stop status is continued after recovery from the failure.
Failure during operation:
LU indication is held upon recovery from the failure and the inverter trips with alarm output.

2 Active
The inverter restarts with the frequency at the momentary power failure when 0.5s elapses after recovery from the fail

3 Active
The inverter restarts with the starting frequency when 0.5s elapses after recovery from the failure.

2,
 3 = valid upon recovery from the failure with LU being on.

The table below lists approximate LU indication times for a momentary power failure during operation.

Inverter Type (kW)	0.1	0.2	0.4	0.75	1.5	2.2
Time (s)	0.6	1.2	2.6	4.8	3.0	5.0

F15 Frequency limiter (High)

Factory setting	Change during operation
70Hz	○

F16 Frequency limiter (Low)

Factory setting	Change during operation
0	○

This function sets the upper and lower limits of output frequencies.

0
to
 1 2 0 } 0 to 120Hz can be set with a resolution of 1Hz.

If the upper limit and lower limit settings are reversed, the upper limit is valid and the lower limit is ignored. Hence, the operation is always performed with the upper limit regardless of the frequency setting.

Change during operation: X = impossible, △ = possible (enabled by using FUNC DATA), ○ = possible (enabled by using)

F17 Gain
(for frequency setting signal)

Factory setting	Change during operation
0	X

This function outputs the frequency obtained by multiplying the reference frequency by a ratio.

This function selects an analog input signal level with a value from to that is set by function .

The maximum frequency is output at +10VDC (20mA DC).

The maximum frequency is output at +5VDC (12mADC).

When this function is used with function (bias frequency), the gain set with this function is valid and the gained frequency is biased.

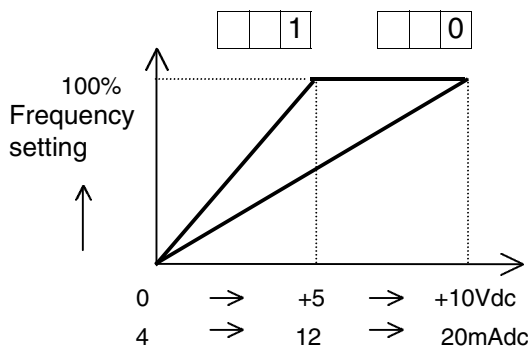

F18 Bias frequency

Factory setting	Change during operation
0	○

This function outputs a frequency biased for the analog frequency setting.

to } -120 to 120Hz can be set with a resolution of 1Hz.

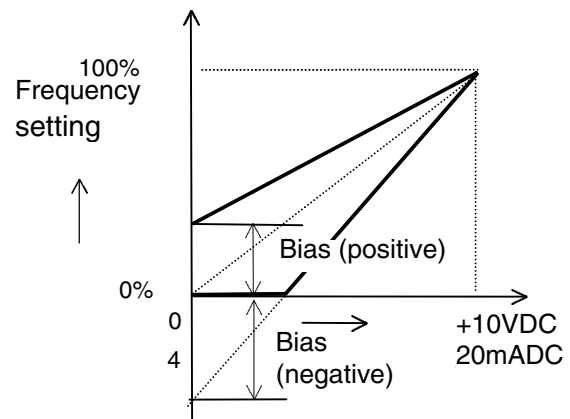

F20 DC injection brake
(starting frequency)

Factory setting	Change during operation
3.0Hz	X

This function sets 3.0Hz (fixed) as the starting frequency of DC injection brake.

F21 DC injection brake (Level)

Factory setting	Change during operation
50%	○

This function sets a DC brake current level. Levels can be set in 1% unit by assuming the level of the inverter rated current to be 100%.

Change during operation: X = impossible, Δ = possible (enabled by using), ○ = possible (enabled by using)

F22 DC injection brake (Braking time)

Factory setting	Change during operation
0.0s	○

This function sets the DC injection braking time.
 0.0 : No DC injection braking
 0.1 to 30.0 : DC injection braking time 0.1 to 30s (in 0.1s step)

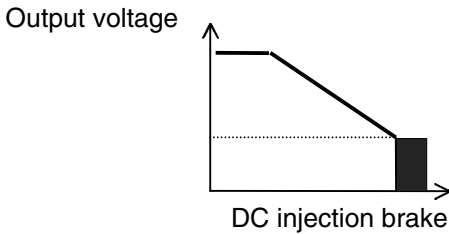
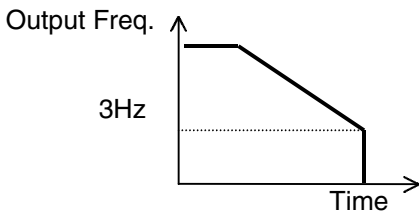

CAUTION
 Do not use the inverter brake function for mechanical holding.
Otherwise injuries could occur.

F23 Starting frequency

F25 Stop frequency

	Factory setting	Change during operation
F23	1Hz	X
F25	1Hz	X

These functions set a starting or stop frequency in a range from 1 to 6Hz in 1Hz step.

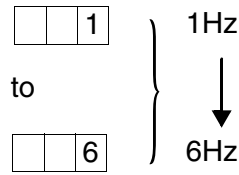

Output frequency in forward/reverse operation

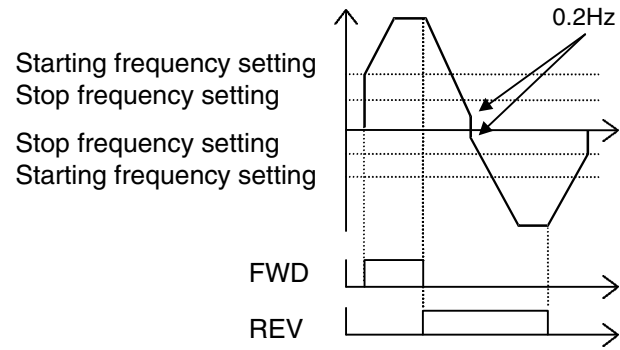

Starting frequency < stop frequency

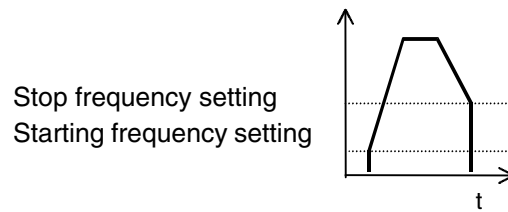

If the set frequency is lower than the stop frequency, the inverter output is 0Hz.

Change during operation: X = impossible, △ = possible (enabled by using FUNC DATA), ○ = possible (enabled by using △ ▽)

F24

Factory setting	Change during operation
0.0	-

Data cannot be changed.

F26 Motor sound (carrier freq.)

Factory setting	Change during operation
15kHz	○

This function changes the motor tone quality by changing the carrier frequency.

		0
--	--	---

 to

	1	5
--	---	---

 Choose among 16 types according to the usage conditions.

- Data code
- 0 : 0.75kHz (Low carrier)
 - 1 : 1kHz
 - 2 : 2kHz
 - 15 : 15kHz (High carrier, low noise)

Note: When the inverter is operating at 9kHz or higher carrier frequency, the carrier frequency for may be reduced to 8kHz automatically to protect the inverter.

F27 Motor sound (sound tone)

Factory setting	Change during operation
0	○

This function adjusts the motor operation sound when a value of 7 or less is set with function F26.

		0
--	--	---

 Level 0
 to

		3
--	--	---

 Level 3

F30 FM terminal (voltage adjust)

Factory setting	Change during operation
100%	○

This function regulates the frequency meter voltage level output to the FM terminal in the range from 0 to 200% (in 1% step).

		0
--	--	---

 (Full scale about 0VDC)
 to

2	0	0
---	---	---

 (Full scale about 11VDC)

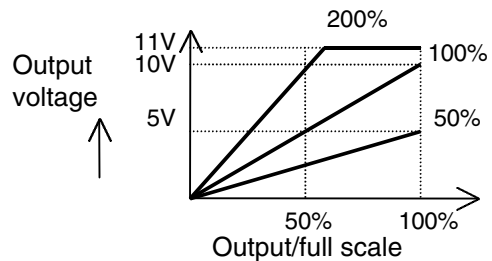

Note: Output to the FM terminal is pulse output with constant frequency and variable duty.

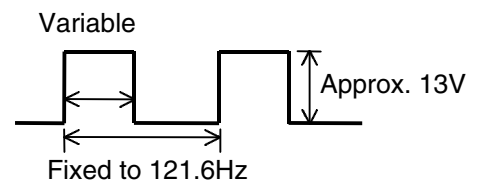

Change during operation: X = impossible, Δ = possible (enabled by using

		FUNC DATA
--	--	-----------

), ○ = possible (enabled by using

--	--	--

)

F31 FM terminal (Function)

Factory setting	Change during operation
0	△

This function selects the contents of output to the FM terminal.

- 0 Output frequency (maximum output frequency = 100%)
- 1 Output current (inverter rated current x 2 = 100%)
- 2 PID feedback value (full scale = 100%)
- 3 DC link circuit voltage (500VDC = 100%)

F36 30Ry operation mode

Factory setting	Change during operation
0	X

This function sets the operation mode of alarm output for any fault (30Ry).

F36	Normal operation	Tripped
0 (Excited when tripped)		
1 (Normally excited)		

1) The status without inverter power supply is the same as the status when inverter is tripped.

E01 X1 terminal (function selection)

E02 X2 terminal

E03 X3 terminal

	Factory setting	Change during operation
E01	0	X
E02	2	X
E03	3	X

0 Multistep frequency selection 1 (SS1)

1 Multistep frequency selection 2 (SS2)

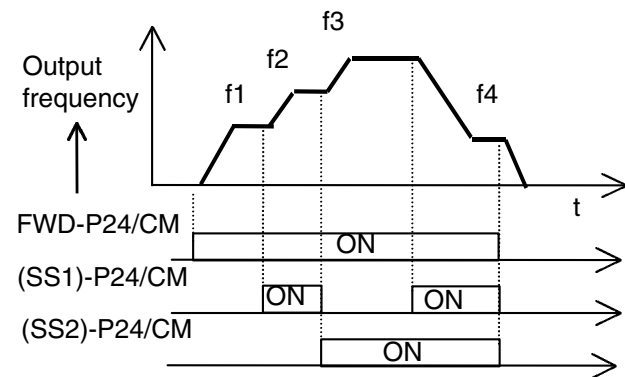

- f1: Frequency selected with F01 (keypad panel/analog/freq. setting POT)
- f2: Frequency selected with C05
- f3: Frequency selected with C06
- f4: Frequency selected with C07

OFF input is assumed if SS1 or SS2 is not selected.

Change during operation: X = impossible, △ = possible (enabled by using FUNC DATA), ○ = possible (enabled by using)

- 2 Coast-to-stop command (BX)
Inverter output is cut when the BX terminal is connected to the P24/CM terminal.
OFF input is assumed when BX is not selected.
- 3 Alarm reset (RST)
The alarm output is released between the RST and P24/CM terminals when power is turned on.
The trip status is released between the RST and P24/CM terminals when power is turned off.
(Refer to 6-2 Alarm Reset on page 6-3)
- 4 External alarm (THR)
Inverter trips with OH2 when the THR terminal is disconnected from the P24/CM terminal.
ON input is assumed when THR is not selected.
- 5 Write enable command for keypad (WE-KP)
Function change from the keypad panel is disabled when the WE-KP terminal is disconnected from the P24/CM terminal.
Function change from the keypad panel is enabled when the WE-KP terminal is connected to the P24/CM terminal.
ON input is assumed when WE-KP is not selected.
- 6 PID control cancel (Hz/PID)
PID control operates when the Hz/PID terminal is disconnected from the P24/CM terminal and does not operate when they are connected.
OFF is assumed when the Hz/PID is not selected.

Hz/PID is valid only when function H 2 0 is set to 1 or 2.
(PID control operation).
- 7 Link operation selection (LE)
Operation setting can be done by commands from RS485 when the LE terminal is connected to the P24/CM terminal.
A command from RS485 is ignored when the LE terminal is disconnected from the P24/CM terminal.
ON input is assumed when LE is not selected.

LE is valid only when function 0 0 0 is set to 1 (option operation).

C01

C02 Jump frequency 1, 2, 3

C03

	Factory setting	Change during operation
C01	0.0Hz	○
C02	0.0Hz	○
C03	0.0Hz	○

These functions jump frequencies to prevent overlap between the load mechanical resonance point and inverter output frequency. Up to three jump points can be set. These function do not operate when 0Hz is set. No frequency is jumped during acceleration and deceleration. If three continuous frequencies are set, the total of the three jump widths is set as the jump width.

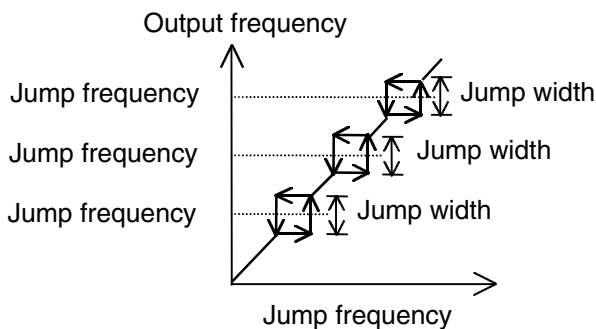

C04 Jump frequency (Hysteresis)

Factory setting	Change during operation
3Hz	○

This function sets a jump width in a range from 0 to 30Hz in 1Hz step.

C05 Multistep frequency 1

C06 Multistep frequency 2

C07 Multistep frequency 3

	Factory setting	Change during operation
C05	0.0Hz	○
C06	0.0Hz	○
C07	0.0Hz	○

These functions set a multistep frequency from 0 to 120Hz in 0.1Hz step (for 99.9 Hz or less) or 1Hz step (for 100Hz or more) by switching the external contact signal. The ON and OFF of terminal function SS1/SS2 (see explanation of E01, E02, and E03) switches between the frequencies set by these functions C05, C06, and C07.

P00 Motor characteristics

Factory setting	Change during operation
2	○

This function removes abnormalities in the output current such as current vibration.

0 Current vibration is not suppressed.

to

1 0 Current vibration is minimized.

Change during operation: X = impossible, △ = possible (enabled by using FUNC DATA), ○ = possible (enabled by using)

H01 Operation time

This function displays the integration time of power supply applied to the inverter. 0 to 655 are displayed to indicate 0 to 65500 hours. If the integration time exceeds 65500 hours, 65500 is displayed continuously. While the total of power supply times is less than one hour, the times are not integrated.

H02 Trip history

This function memorizes the history of the last four protection operations. Each data item can be called using the \checkmark key. The calling procedure is shown below: The contents of a new alarm is stored in the data area for the history of the latest alarm. At this time, the history of the latest alarm is stored in the data area for the second latest alarm. The histories of the second and third latest alarms are moved in this way and the history of the fourth latest alarm is deleted. Stored trip histories are not deleted although data initialization is executed with H03.

No.	Procedure	Display example	Remarks
1	Call $\boxed{H02}$	$\boxed{H02}$	
2	Press the $\boxed{\text{FUNC DATA}}$ key	$\boxed{OU2}$	The contents (history) of the latest alarm are displayed.
3	Press the \checkmark key	$\boxed{OH2}$	The contents of the second latest alarm are displayed.
4	Press the \checkmark key	$\boxed{OC1}$	The contents of the third latest alarm are displayed.
5	Press the \checkmark key	$\boxed{- - -}$	The contents of the fourth latest alarm are displayed. (This example is for no history.)
6	Press the \checkmark key	$\boxed{E n d}$	

5

Change during operation: X = impossible, Δ = possible (enabled by using $\boxed{\text{FUNC DATA}}$), \bigcirc = possible (enabled by using \checkmark)

H03 Data initialization

Factory setting	Change during operation
0	X

This function initializes data items set with all functions to values set in the factory.

0 Manually set value

to

1 Initialized (factory set value)

The display is changed from 0 to 1 when the **STOP** and **△** keys are pressed simultaneously.

When the **FUNC DATA** key is pressed under this condition, initial data is written and a frequency set by the built-in POT (VR) is displayed automatically.

H04 Retry

Factory setting	Change during operation
0	△

This function selects a retry operation if the inverter is tripped.

0 : No retry

to

1 : The retry count is fixed to 5 and retry starts when 0.5s elapses after tripping.

Retry is attempted only for an overcurrent/over-voltage trip that occurs during operation.

H06 Cooling fan on/off control

Factory setting	Change during operation
0	△

0 : ON-OFF No control (always on)

to

1 : ON-OFF Control
(The fan is turned off when the inverter temperature becomes low after operation is stopped.)

H20 PID control (Mode select)

Factory setting	Change during operation
0	X

0 : Inactive

1 : Active (forward)

2 : Active (reverse)

} Select a PID control operation.

The feedback signal value (%) is displayed by assuming the full scale to be 100% when a PID control operation is selected.

Change during operation: X = impossible, △ = possible (enabled by using **FUNC DATA**), ○ = possible (enabled by using **△** **▽**)

H21 PID control (Feedback signal select)

Factory setting	Change during operation
1	X

This function selects a PID control feedback signal.

0 Terminal 12 (0 to +10VDC)

1 Terminal C1 (4 to 20mADC)

2 Terminal 12 (+1 to +5VDC)

H22 PID control (P-gain)

Factory setting	Change during operation
0.01	○

This function sets a P-gain.

1 to 1 0 0 P-gain from 0.01 to 10.0 times (1 to 1000%) (in increment of 0.01 step)

H23 PID control (I-gain)

Factory setting	Change during operation
0.0s	○

This function sets an integral time.

0 : No integration

0 1 to 9 9 9 : Integral time 0.1 to 999s

(in 0.1s step for 99.9s or less, 1s step for 100s or more)

H24 PID control (D-gain)

Factory setting	Change during operation
0.00s	○

This function sets a derivative time.

0 : No derivative

1 to 1 0 0 : Derivative time 0.01 to 10.0s (in 0.01s step)

H25 PID control (Feedback filter)

Factory setting	Change during operation
0.5s	○

This function sets a filter time constant of PID feedback.

0 0 to 6 0 0 : Time constants 0.0 to 60.0s (in 0.1s step)



Change during operation: X = impossible, △ = possible (enabled by using FUNC DATA), ○ = possible (enabled by using)

PID control

In PID control, an output frequency is adjusted to a feedback value.

Use to set a frequency and to make the feedback value and the reference value equal.

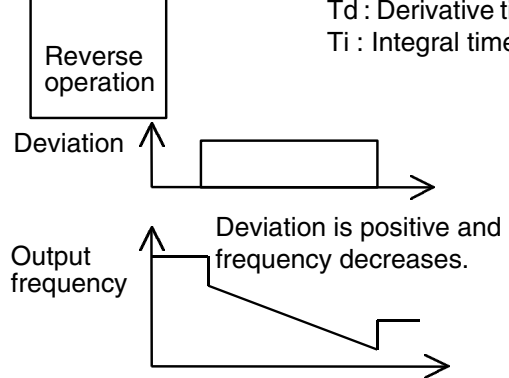
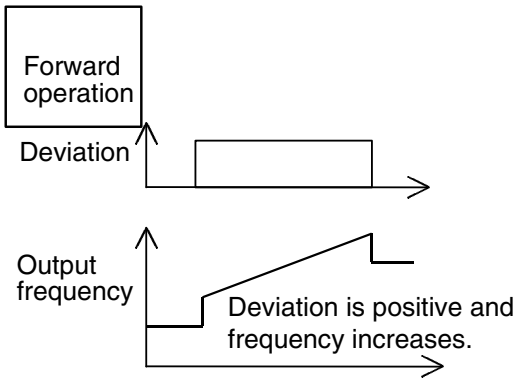
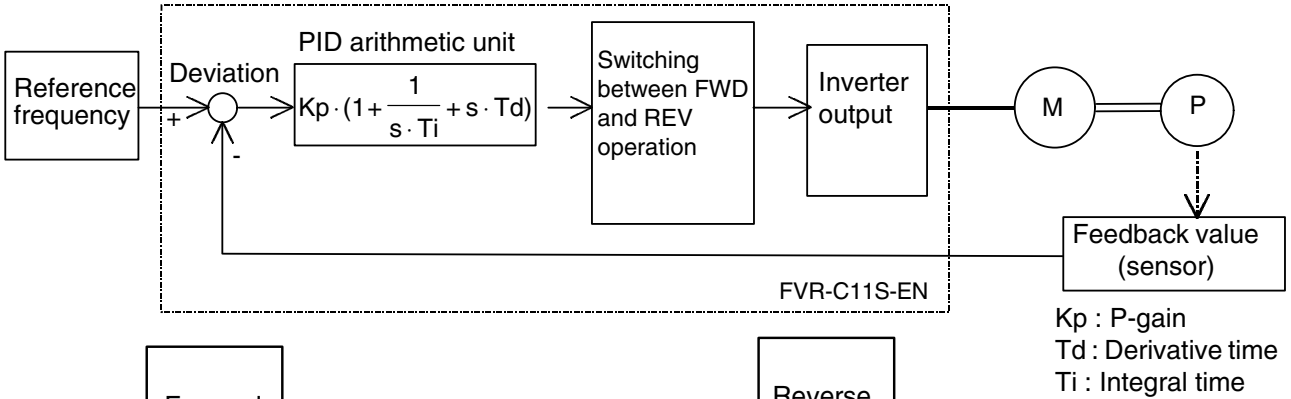

Option selection (RS485 communication)

For explanations of "o01" to "o11", refer to the instruction manual that comes with the optional RS485 serial communication unit.

Factory setting	Change during operation
0	△

- : Option inactive
- : Option active

Always set when the optional RS485 serial communication unit is not used. If is set, Er 8 occurs.

Change during operation: X = impossible, △ = possible (enabled by using) , ○ = possible (enabled by using)

6 Protective Function

6-1 List of protective functions

When the protective function is activated, inverter output is instantly cut off (while the motor coasts until it is stopped), and an alarm is issued, and the details of the alarm are displayed on the keypad panel.

Alarm Name	Keypad panel display	Contents of operation	
Overcurrent	OC1	During acceleration	If the inverter output current momentarily exceeds the overcurrent detection level because of an overcurrent in the motor or the short-circuit in the output circuit, the output is shut down, an alarm is issued, and the inverter is tripped.
	OC2	During deceleration	
	OC3	While running at constant speed	
Overvoltage	OU1	During acceleration	If the DC voltage of the main circuit exceeds the overvoltage detection level because of an increase in the regenerating current from the motor, etc., output is shut down, an alarm is issued, and the inverter is tripped. However, protection against inadvertent overvoltage loading (e.g. high-voltage line) might not be provided.
	OU2	During deceleration	
	OU3	While running at constant speed	
Undervoltage	LU	If the DC voltage of the main circuit falls below the undervoltage detection level because of a lowered power supply, output is shut down to protect the inverter. If the restart function after momentary power failure is not activated, an alarm is issued and the inverter is tripped. If the restart function is activated, the inverter restarts automatically with no alarm. For further details of the protective function, refer to the descriptions of Function F14.	
Overheating of heat sink	OH1	If the temperature of the heat sink used for cooling the rectifier diodes and IGBTs rises because of cooling fan failure, etc., protective function is activated to stop operation, an alarm is issued, and the inverter is tripped.	

Alarm Name	Keypad panel display	Contents of operation
External Alarm	OH2	If the control circuit terminal THR (functional change of X1 to X3 terminals) is set to OFF, an alarm is issued and the inverter is tripped.
Motor overload	OL	If the motor current exceeds the operating level set by the electronic thermal O/L relay, output is shut down to protect the motor, an alarm is issued, and the inverter is tripped.
Inverter overload	OLU	If the output current exceeds the inverter rated overload current, output is shut down, an alarm is issued, and the inverter is tripped.
Memory Error	Er1	If memory error occurs, such as a missing or invalid data, output is shut down, an alarm is issued, and the inverter is tripped.
CPU Error	Er3	If CPU error occurs because of noise, etc., output is shut down, an alarm is issued, and the inverter is tripped.
RS485 Communication Error	Er8	If an error occurs in serial communication via the RS485, output is shut down, an alarm is issued, and the inverter is tripped. For further details, refer to the instruction manual for RS485 communication cards.



Table 6-1-1 List of Protective Functions

6-2 Alarm Reset

To release the trip status, enter the reset command by pressing the reset key or from terminal (RST) after removing the cause of the trip. Since the reset command is an edge operation, be sure to input a command string such as OFF → ON → OFF as shown in Figure 6-2-1.

When releasing the trip status, set the operation command to OFF. When the operation command is set to ON, check that operation starts after resetting.

If the cause of tripping is Er1, reset the error and initialize data. If the inverter is not reset, contact Fuji Electric.

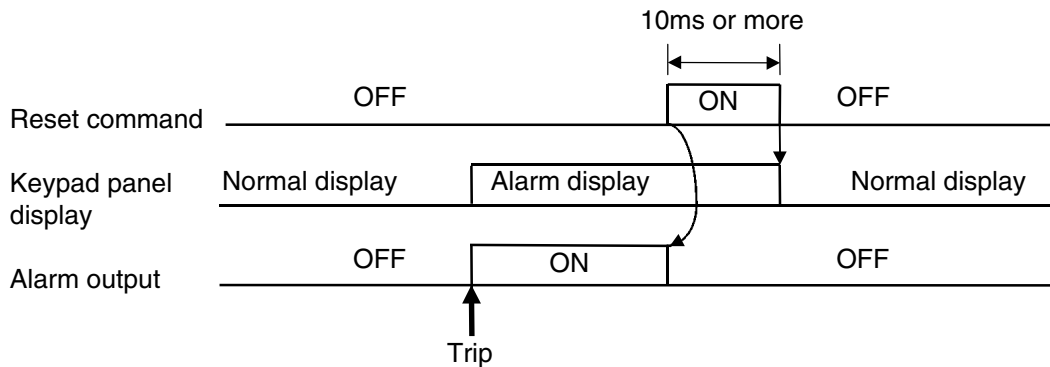

Figure. 6-2-1 How to input the reset command



WARNING

If alarm reset is activated with operation signal ON, the inverter suddenly restarts which may be hazardous. Be sure to disable the operating signal when releasing the trip status:
Otherwise fire could occur.

7 Troubleshooting

7-1 In case of tripping

In the event the inverter tripping, diagnose by the help of the alarm display as shown below.

1) Overcurrent (OC)

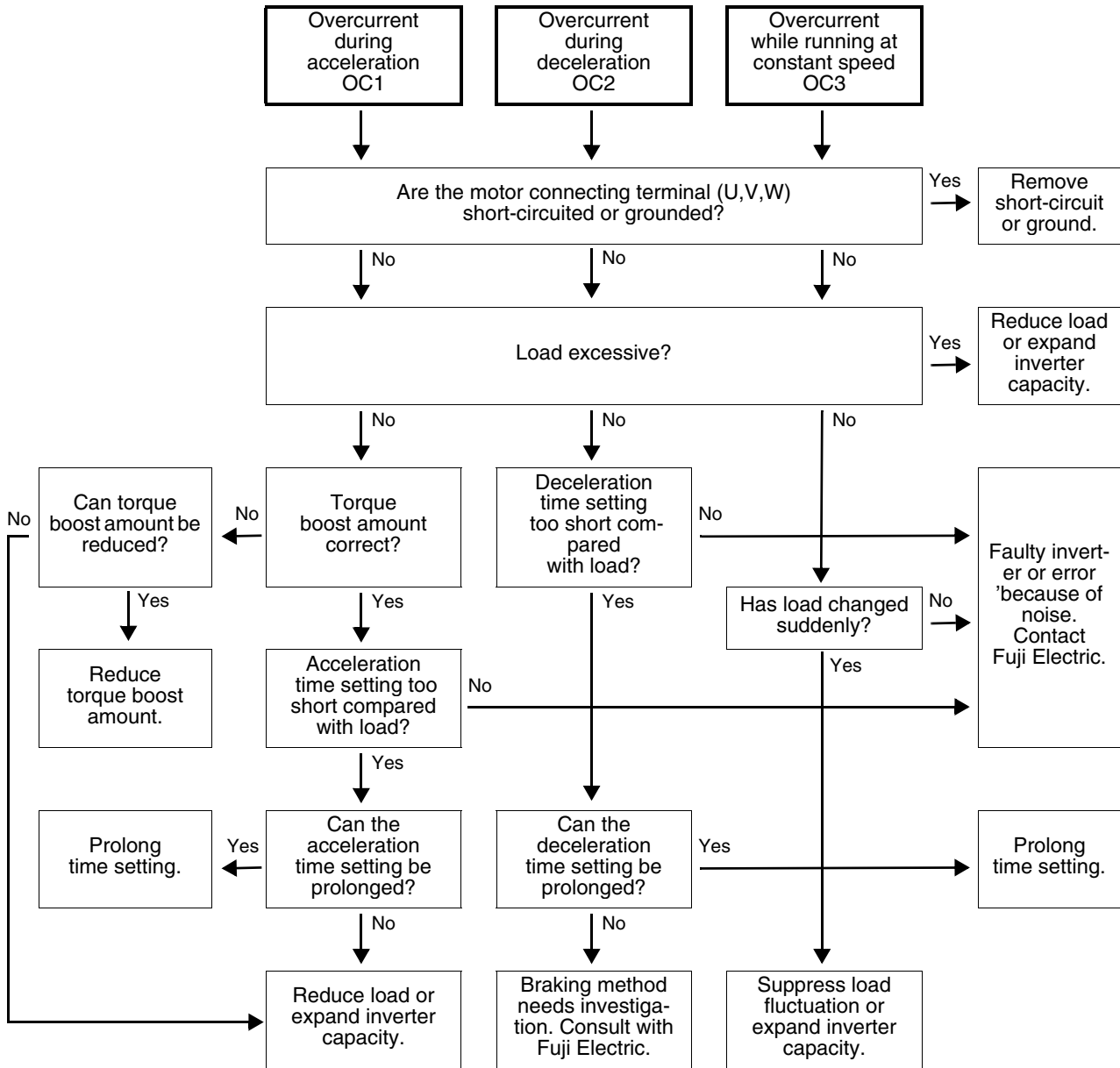

7

2) Overvoltage(OU)

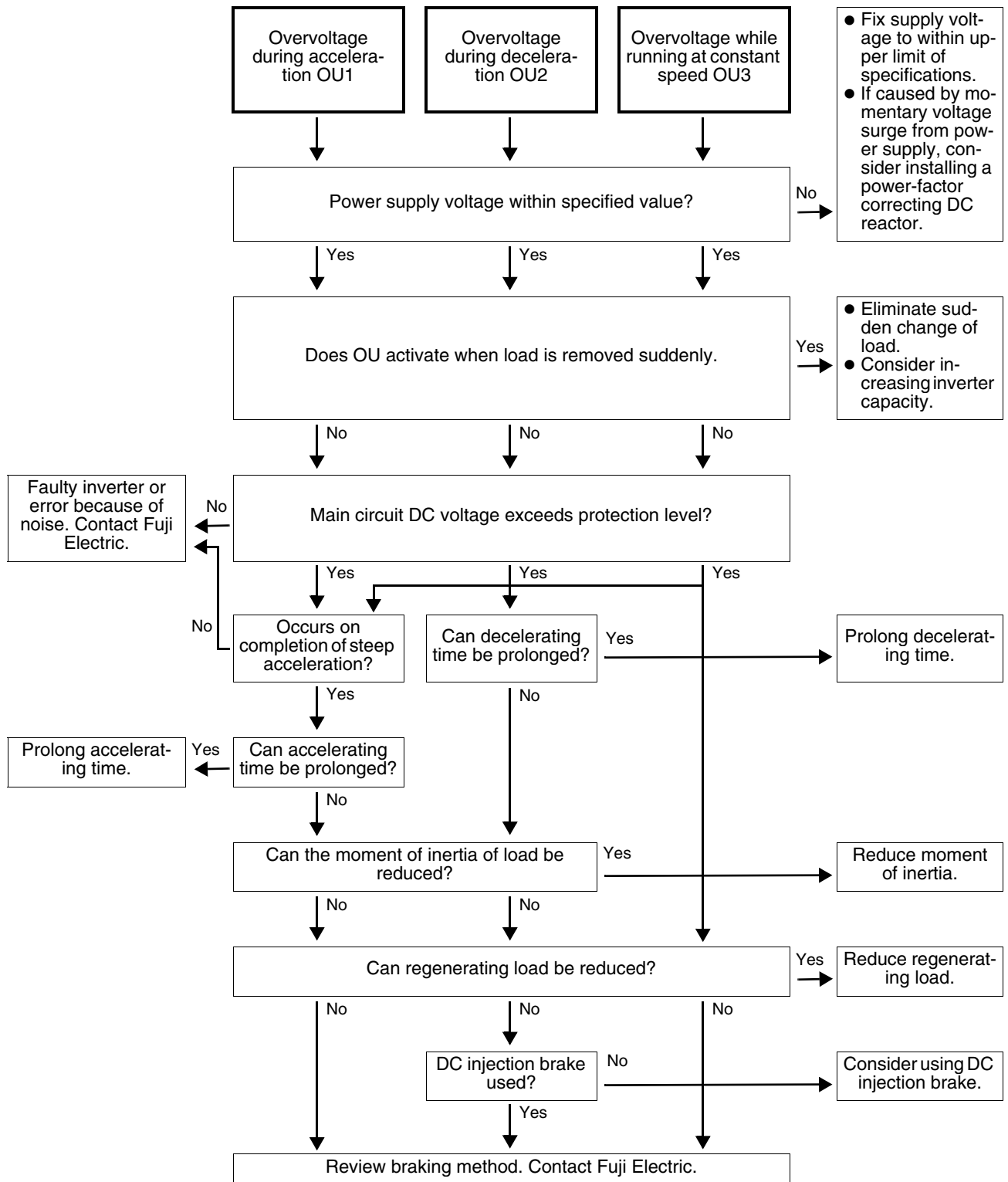

3) Undervoltage(LU)

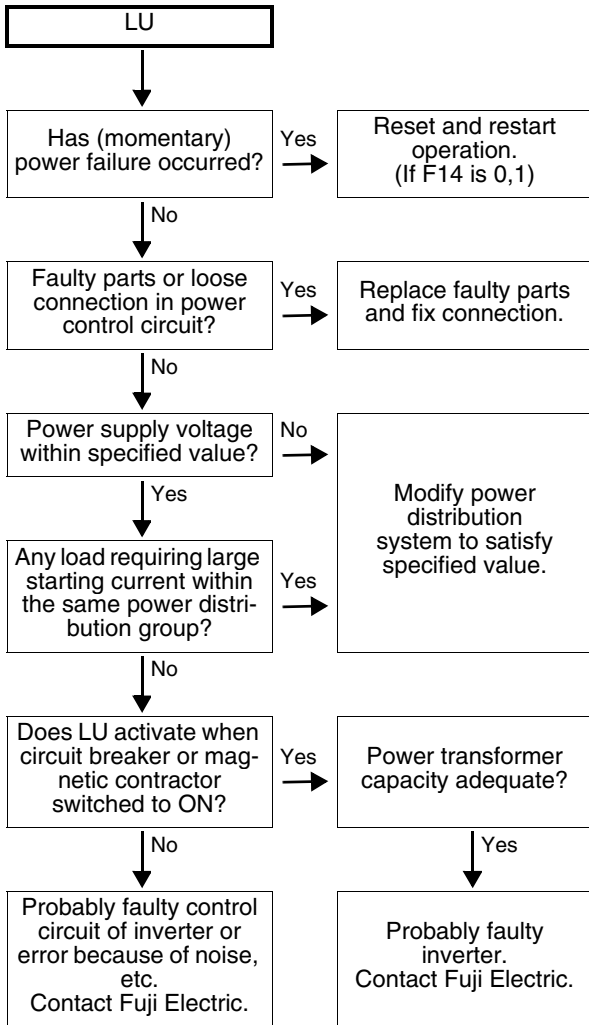

4) Overheating of heat sink (OH1)

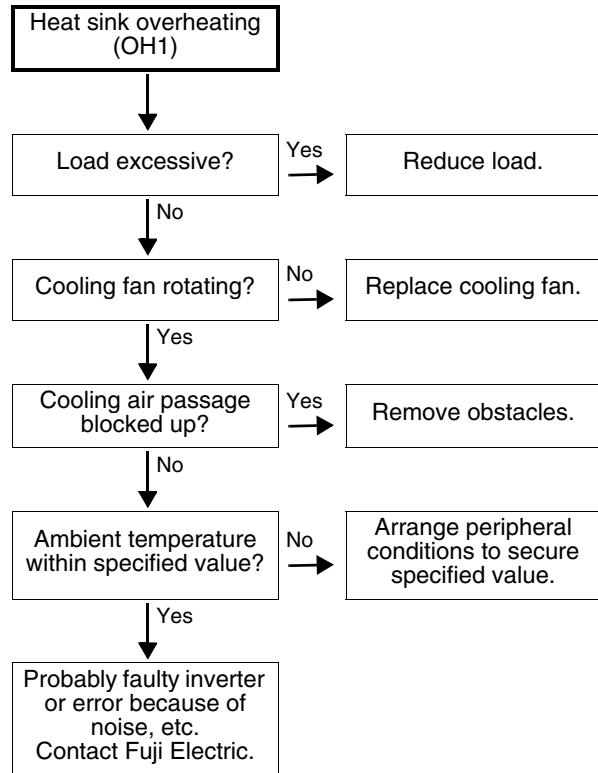

7

5) External alarm input (OH2)

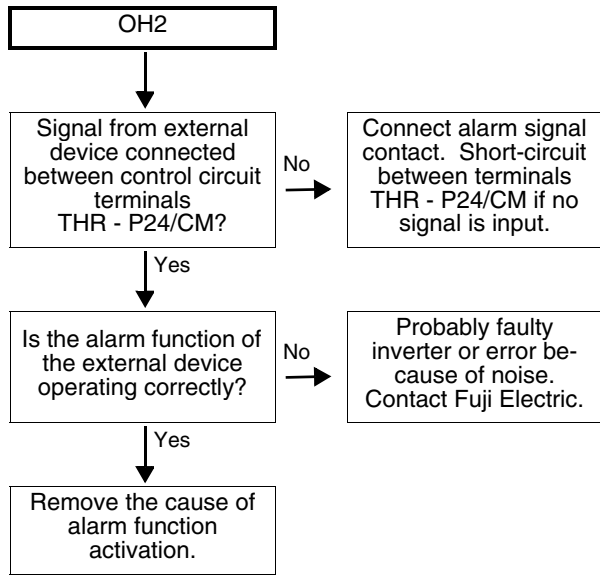

6) Inverter overload (OLU) or motor overload (OL)

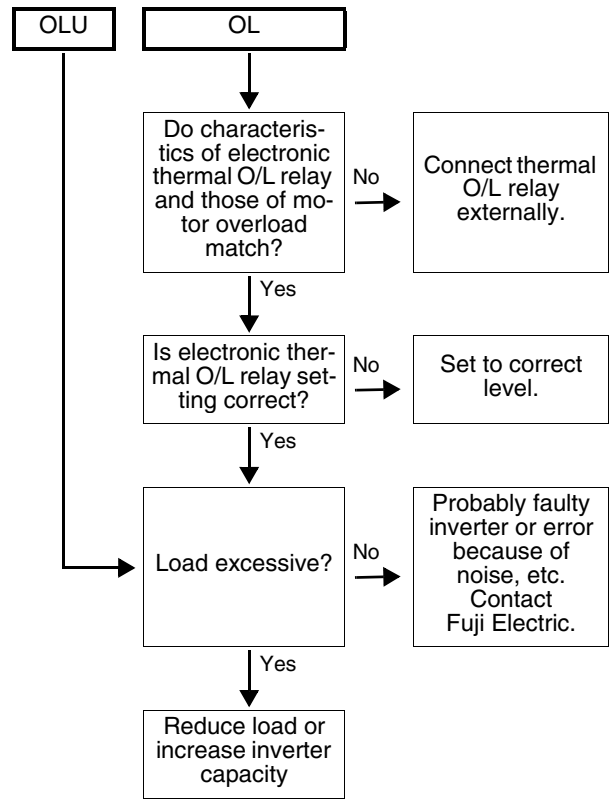

7) Memory error (Er1) CPU error (Er3)

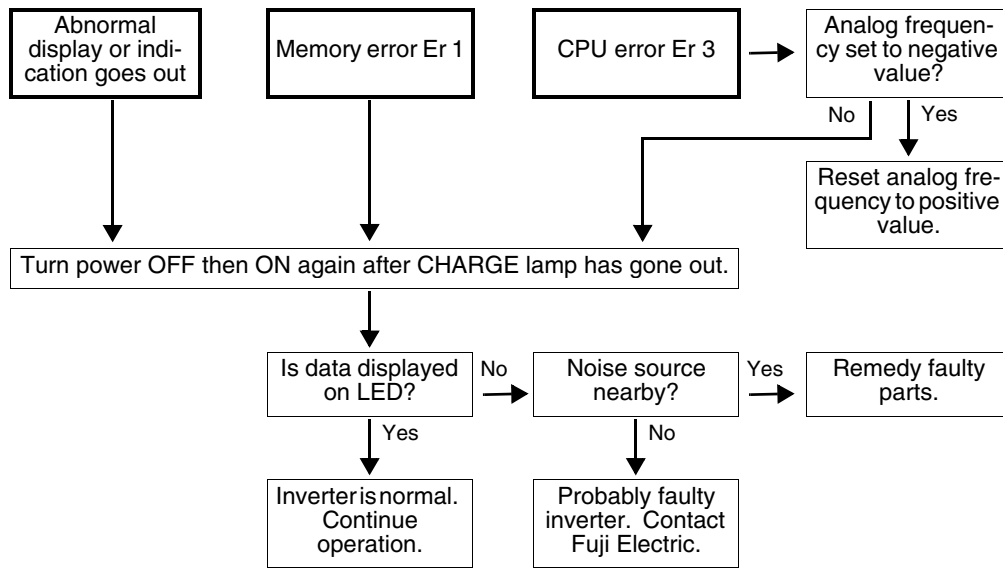

7

8) RS485 Communication Error (Er8)
[In case RS485 communication is not used*]

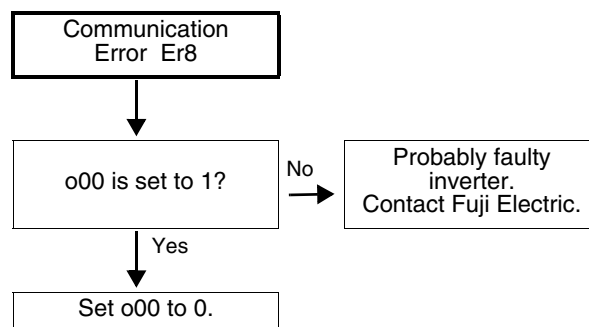

* For Er8 measures when using RS485, refer to the instruction manual for optional RS485 communication card.

7-2 Other trouble

1) When motor does not rotate.

Note: Verify the function settings for the operation commands and frequency setting values on the keypad panel.

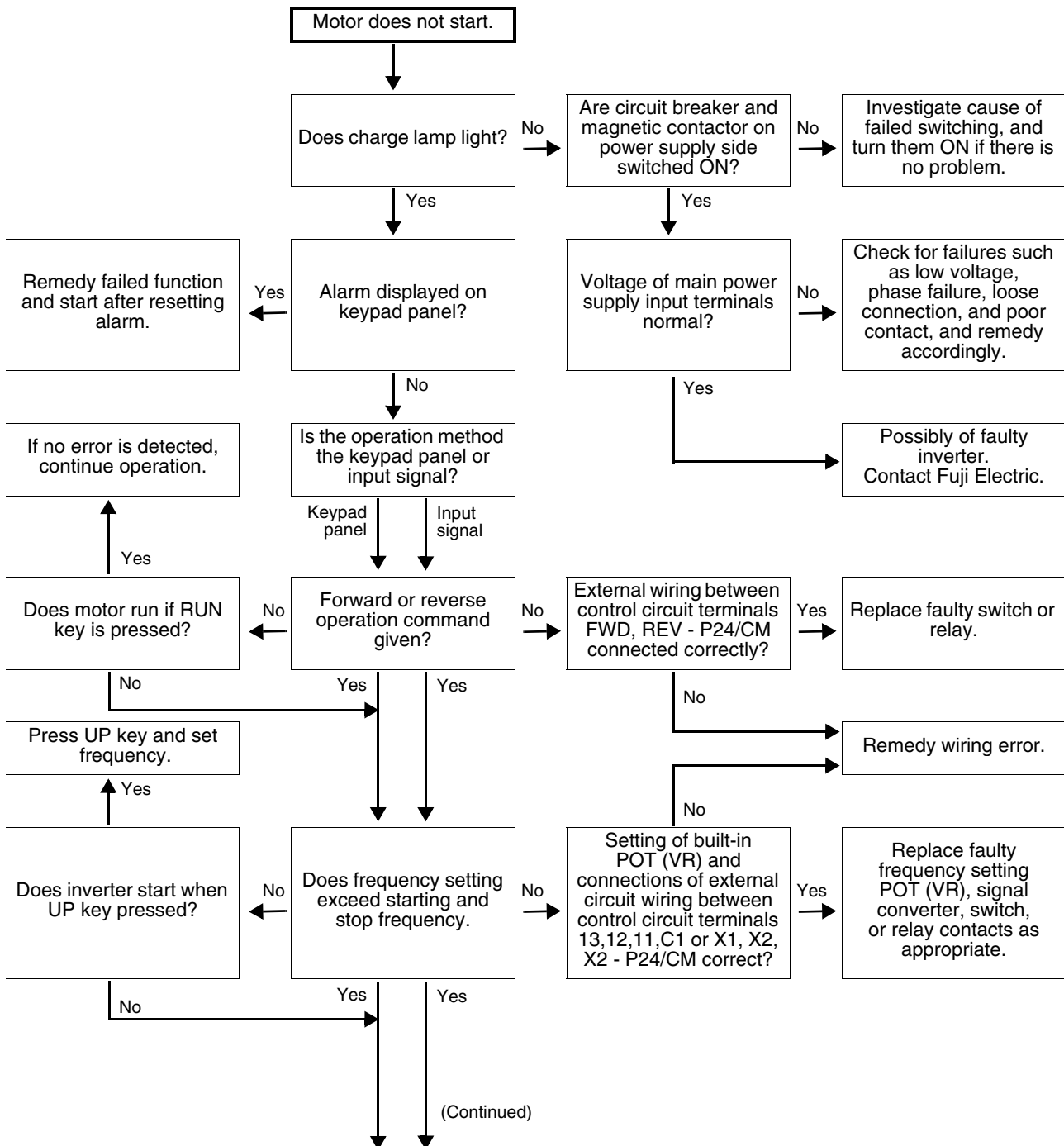

7

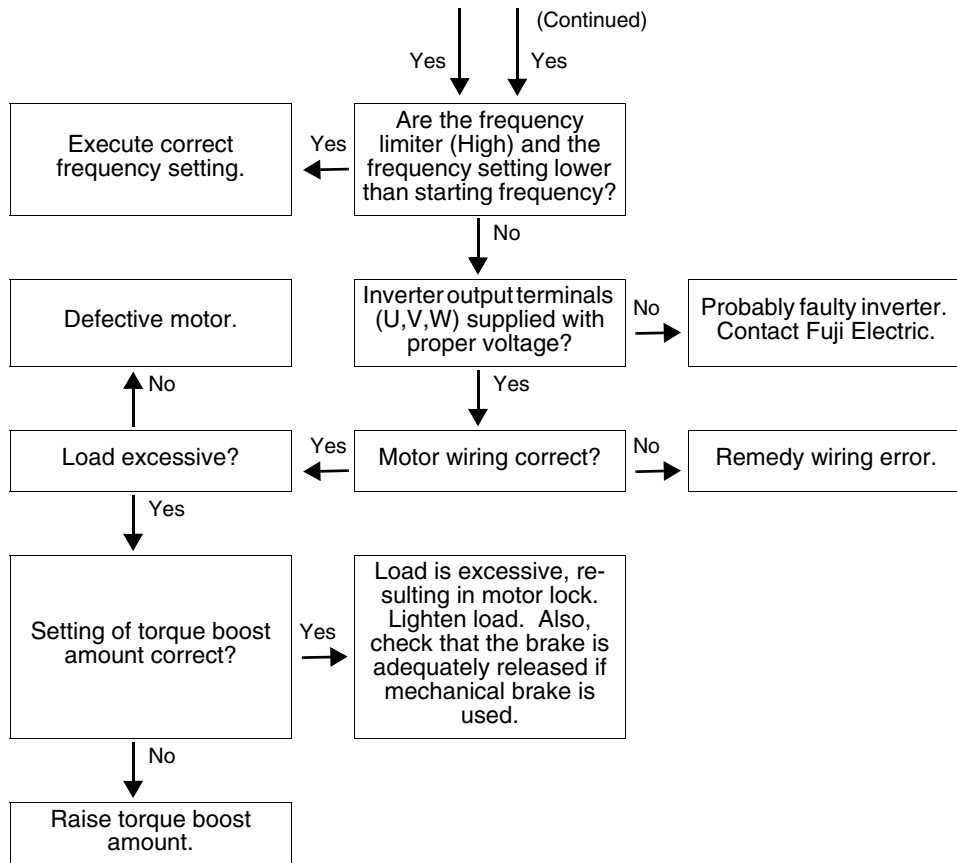

The motor does not rotate if the following commands are given.

1. An operation command is given while coast-to-stop command is output to the control terminals.
2. Both operation command FWD and REV are input.

2) When motor rotates but the speed does not change.

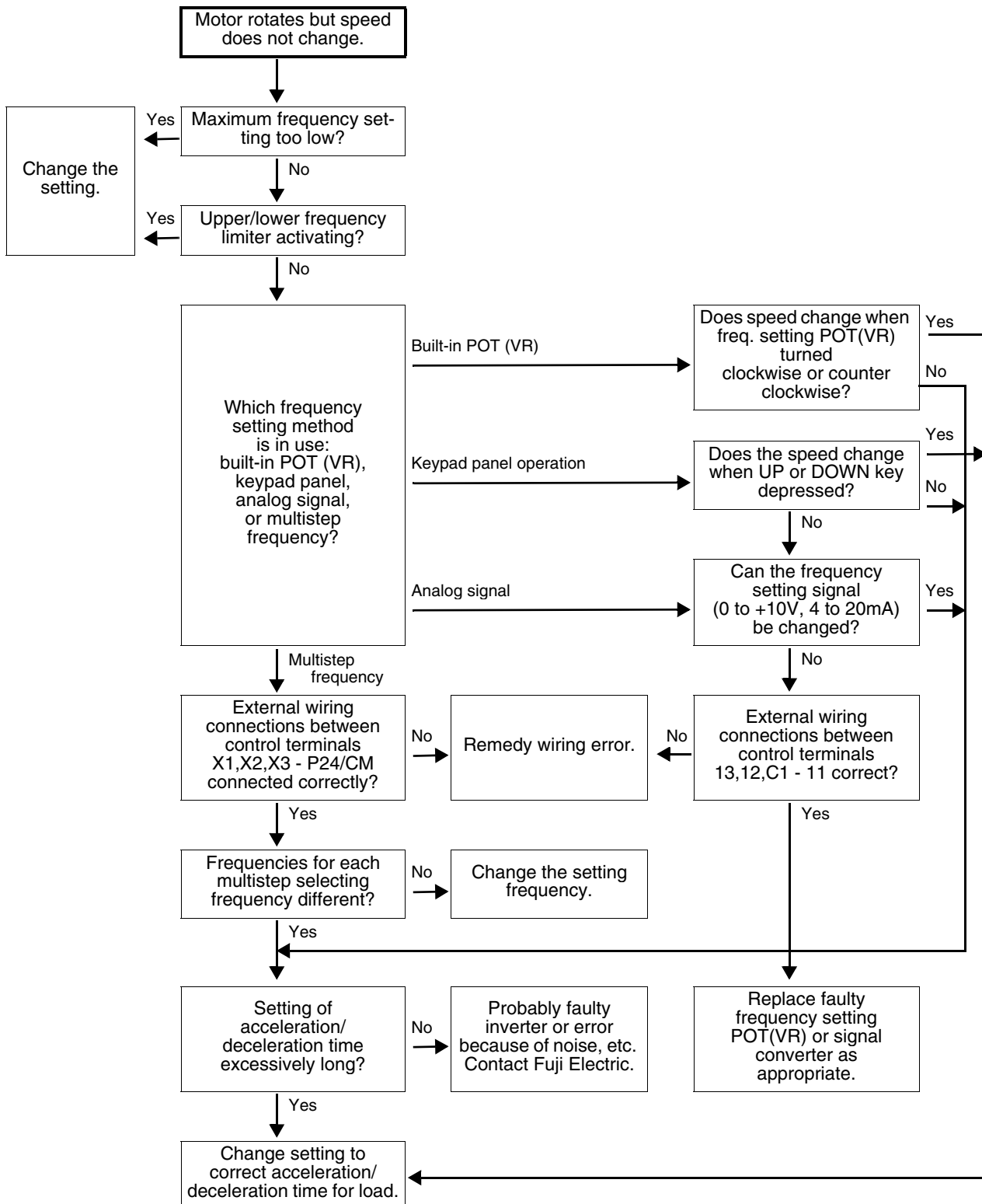

7

In the following cases, change of motor speed is also restricted.

1. Bias frequency (F18) setting value is large.
2. Signals are input from both control terminals 12 and C1 and there is no significant change in the added value.
(When F01 is 3)
3. Load is excessive and stall prevention function is activated.

3) When motor stalls during acceleration

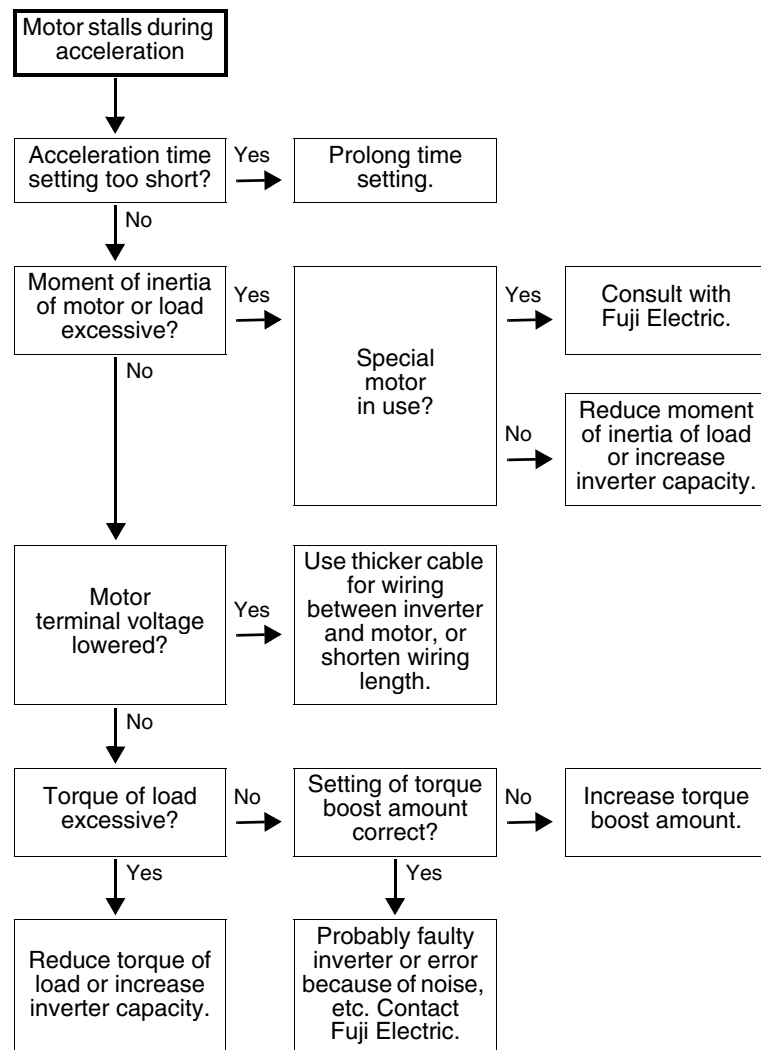

4) When motor generates abnormal heat

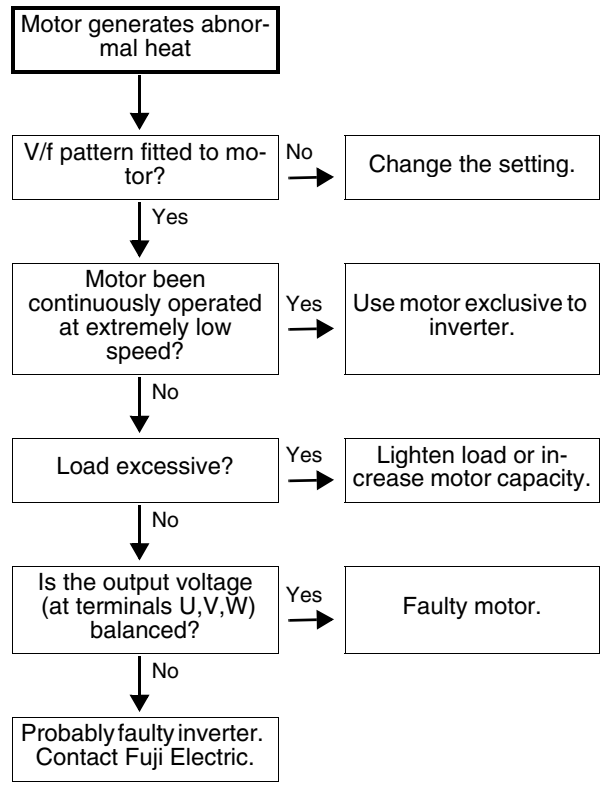

7

5) When function change disabled

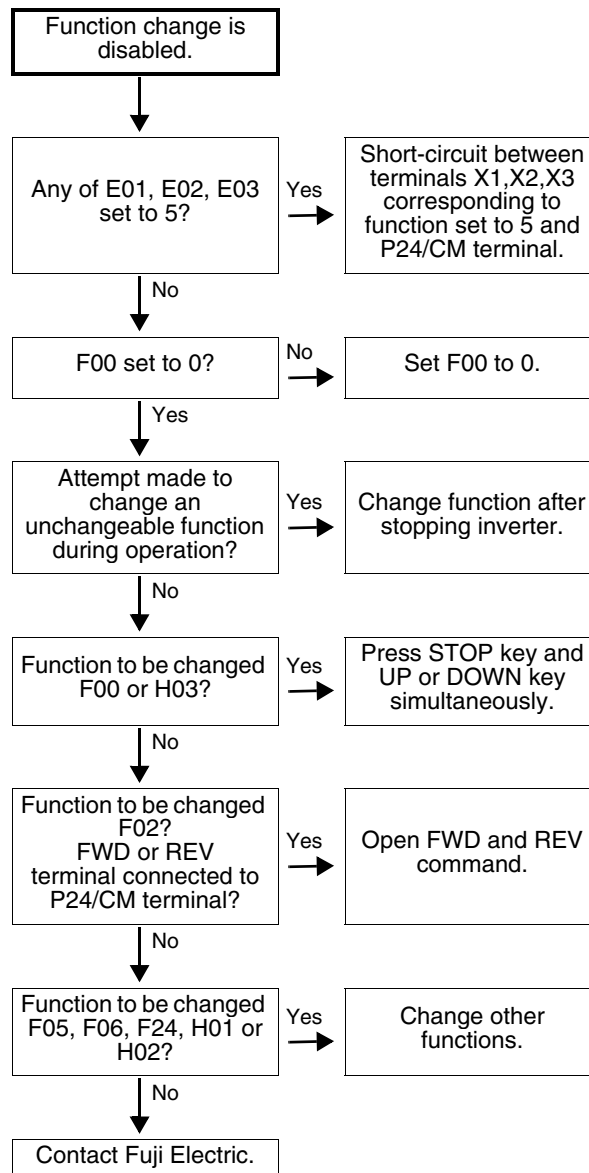

7

8 Maintenance and Inspection

Execute the daily inspection and periodic inspection for preventing a fault and ensuring long-term reliability.

Note the following regarding the work.

8-1 Daily Inspection

During the operation and conduction, the visual inspection for abnormal operation is executed from the outside without removing the covers.

Inspections are usually done to check the following:

1. The expected performance (satisfying the standard specification) is obtained.
2. The environment satisfies the standard specification.
3. The keypad panel display is normal.
4. There are no abnormal sound, vibrations or unpleasant odors.
5. There are no overheating marks or discoloration.

8-2 Periodic Inspection

The periodic inspection must be executed after stopping the operation and cutting off the power source and removing the surface cover.

After power-off, time is needed for the smoothing capacitors in the DC section in the main circuit to discharge. To prevent electric shock, make sure that the voltage falls down to the safety value (25VDC and below) using a multimeter after the charge lamp (CRG) goes off.



WARNING

1. Start inspection five minutes or more after turning off the power supply. (Check that the charge lamp (CRG) goes off, and check the voltage is 25V DC or below between terminals P(+) and N(-).
There is danger of electric shock.
2. Only the designated person can perform the maintenance and replace components. (Take off any metal objects such as a watch or ring.)
(Use insulated tools.)
3. Never modify the inverter.
There is danger of electric shock or injury.

Check part		Check item	How to inspect	Evaluation criteria
Environment		<ol style="list-style-type: none"> 1. Check the ambient air temperature, humidity, vibration, atmosphere (dust, gas oil mist, waterdrops) 2. Are foreign matter or dangerous objects such as tools not left around the equipment? 	<ol style="list-style-type: none"> 1. Measure by visual inspection and the meter. 2. With visual inspection 	<ol style="list-style-type: none"> 1. The specified standard value must be satisfied. 2. No foreign matter or dangerous objects left near the inverter?
Voltage		Are the voltages in the main circuit and the control circuit normal?	Measure with the multimeter.	The specified standard value must be satisfied.
Keypad panel		<ol style="list-style-type: none"> 1. Is the display hard to read? 2. Are the characters complete? 	1., 2. Visual inspection	1., 2. The display can be read and is not abnormal.
Structure such as a frame or cover		<ol style="list-style-type: none"> 1. Abnormal sound or vibration? 2. Loose bolts (part to be tightened) ? 3. Deformation or damage? 4. Discoloration by overheating? 5. Stains and dust? 	<ol style="list-style-type: none"> 1. With Visual inspection and hearing 2. Tighten more 3., 4., 5. With visual inspection 	1., 2., 3., 4., 5. Not abnormal.
Main circuit	Comon	<ol style="list-style-type: none"> 1. Loose and missing bolts? 2. Deformation, cracks, damage, and discoloration by overheating and deterioration in the equipment and the insulation? 3. Stains and dust? 	<ol style="list-style-type: none"> 1. Tighten more 2., 3. Visual inspection 	<ol style="list-style-type: none"> 1., 2., 3. Not abnormal. <p>Note: A discolored short-circuiting bar does not indicate a problem.</p>



Check part		Check item	How to inspect	Evaluation criteria
Main circuit	Conductor and wire	1. Discoloration and distortion of a conductor by overheating? 2. Cracks, crazing, and discoloration of the wire sheath?	1., 2. Visual inspection	1., 2. Not abnormal.
	Terminal block	Not damaged?	Visual inspection	Not abnormal.
	Smoothing capacitor	1. Electrolyte leakage, discoloration, crazing, and swelling of a case? 2. Is a safety valve not out, and are any valves protruding excessively? 3. Measure the capacitance if necessary	1., 2. Visual inspection 3. Measure using the capacitance measuring instrument (Note)	1., 2. Not abnormal. 3. The capacitance is initial value x 0.85 or more.
Main circuit	Resistor	1. Unpleasant smell and crazing of the insulation by overheating 2. No open circuit?	1. Olfactory and visual inspection 2. Visual inspection or use a multimeter by removing a connection on one side.	1. Not abnormal. 2. Less than about $\pm 10\%$ of the indicated resistance value
	Transformer and reactor	Abnormal buzzing or unpleasant smell?	Aural, olfactory, and visual inspection	Not abnormal.
	Magnetic contactor and relay	1. Rattling when operating? 2. Roughness of contact?	1. Aural 2. Visual inspection	1., 2. Not abnormal.

Check part		Check item	How to inspect	Evaluation criteria
Control circuit	Control PC board and connector	1. Loose screws or connectors?	1. Tighten more.	1., 2., 3., 4. Not abnormal.
		2. Unpleasant smell or discoloration?	2. Olfactory and visual inspection	
Cooling system	Cooling fan (1.5 kW minimum)	3. Cracks, damage, deformation, or excessive rust?	3., 4. Visual inspection	1. The fan must rotate smoothly. 2., 3. Not abnormal
		4. Electrolyte leakage or a deformed mark on the capacitor?		
	Ventilation way	1. Abnormal sound or vibration?	1. Aural and visual inspection. Turn with hand. (Make sure power is off)	
	2. Loose of bolts?	2. Tighten more		
		3. Discoloration by overheating?	3. Visual inspection	
		Clogging-up or foreign substance on heat sink or intake/exhaust ports?	Visual inspection	

Table 8-2-1 Periodic inspection list

Note: Use a capacitance measuring instrument available on the market which is easy to use.

Remark: If the equipment is stained, wipe it with a cleaning cloth, which is chemically neutral.
Vacuum-clean the dust.



8-3 Electrical measurements in the Main Circuit

The indicated values depend on the meter types because of harmonic components included in the voltage and current of the main power supply (input) and the output (motor) side of the inverter. Therefore, when measuring with a meter for the commercial power frequency, use the meters shown in Table 8-3-1.

The power-factor cannot be measured using the power-factor meter available on the market which measures the phase difference between voltage and current. When the power-factor must be measured, measure the power, voltage, and current on the input side and output side. Then, calculate the power-factor using the following formulas:

Single-phase

$$\text{Power factor} = \frac{\text{Electric power [W]}}{\text{Voltage [V] x Current [A]}} \times 100 [\%]$$

Item	Input (power supply) side			Output (motor) side			DC circuit (P(+), N(-)) FM, 11 Terminal section
	Voltage waveform 	Current waveform 		Voltage waveform 	Current waveform 		
Meter name	Ammeter A _R	Voltmeter V _R	Wattmeter W _R	Ammeter A _{U,V,W}	Voltmeter V _{U,V,W}	Wattmeter W _{U,W}	DC voltmeter V
Meter type	Moving-iron type	Rectifier or moving-iron type	Power meter	Moving-iron type	Rectifier type ¹⁾	Power meter	Moving-coil type
Symbol			-			-	

Table 8-3-1 Meter for measuring the main circuit

1) When measuring the output voltage by rectifier type meter, an error may occur. Use a digital AC power meter for good accuracy.

[In the case of single-phase input series]

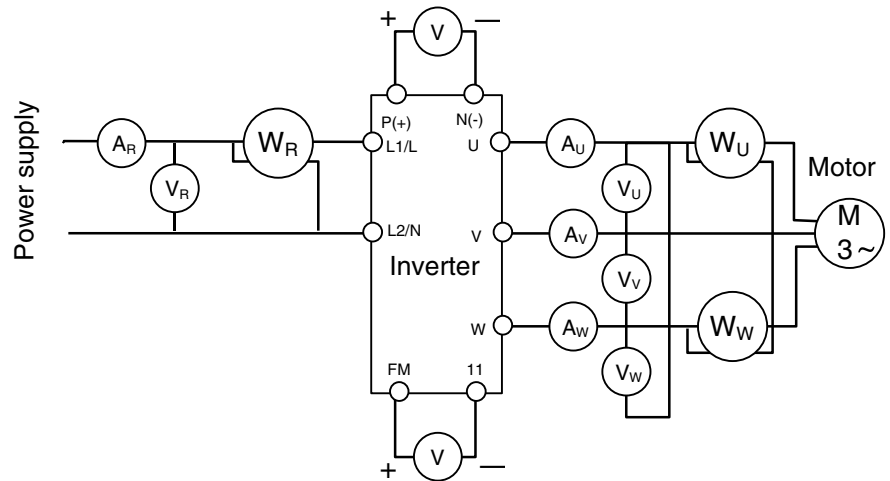

Figure 8-3-1 Diagram for connections of meters

8-4 Insulation Test

As much as possible, do not test the inverter with a megger because an insulation test was done at shipping from the factory. If a megger test must be done, test as described below. If the test method is incorrect, there is a possibility of damaging the product. Incorrect use of test specifications for the dielectric strength test may damage products like megger test. If the dielectric strength test must be conducted, contact your local distributor or nearest Fuji's sales office.

1) Megger test for the main circuit

1. Test with a 500V DC megger.
2. If the test voltage is connected to the control circuit, remove all connection wires to the control circuit.
3. Connect the main circuit terminals using common wires as shown in Figure 8-4-1
4. Execute a megger test only between the common wire connected to the main circuit and the ground (terminal \ominus G).
5. If the megger indicates 5MΩ or more, it is normal. (This is the value measured with an inverter only.)

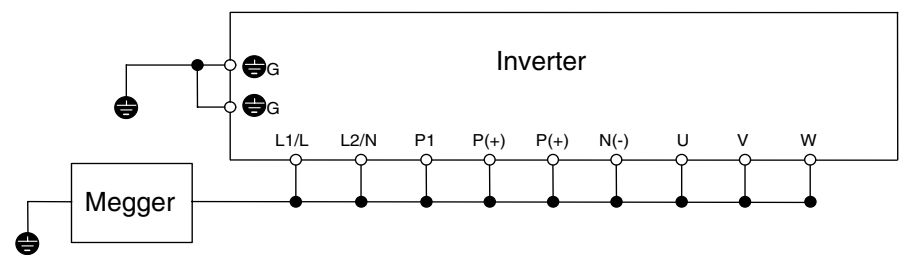

Figure 8-4-1 Megger Test

2) Insulation test in the control circuit

The megger test and the dielectric strength test must not be executed in the control circuit because those parts will be damaged and cannot be repaired.

Use a high-resistance multimeter for the control circuit.

1. Remove all external wiring from the control circuit terminals.
2. Execute a continuity test between grounds. If the result is 1MΩ or more, it is normal.

3) External main circuit and sequence control circuit

Remove wiring from all the terminals of the inverter in order not to apply the test voltage to the inverter.

8-5 Parts Replacement

The life expectancy of a part depends on the type of the part and the environment and the usage conditions. Parts should be replaced as shown in Table 8-5-1.

For spare parts, please contact Fuji distributor.

Part name	Standard term for replacement	Comments
Cooling fan	3 years	Exchange for a new part
Smoothing capacitor	5 years	Exchange for a new part (Decide after a check)
Aluminum electrolytic capacitor on the PC board.	7 years	Exchange for a new part (Decide after a check)
Other parts	-	Decide after a check

Table 8-5-1 Parts replacement

8-6 Inquiries about the Product and Guarantee of the product

1) For inquiries

If there is damage, a fault in the product, or a question about the product, provide the following information to your local distributor or nearest Fuji's sales office:

- a) Inverter type
- b) SER. No. (equipment serial number)
- c) Purchasing date
- d) Inquiry contents (e.g., damaged part and the extent of damage, questions, phenomenon, and status of a fault)

2) Guarantee of the product

The product guarantee term is one year after purchase or 18 months from the year and month of manufacture on the nameplate, whichever expires first.

However, the product will not be repaired free of charge in the following cases, even if the guarantee term has not expired:

1. The cause is incorrect use or inappropriate repairing and modification.
2. The product is used outside the standard specified range.
3. The cause is dropping after purchasing or damage during transport.
4. The cause is earthquake, fire, storm or flood damage, lightening, abnormal voltage, or other natural calamities and secondary disasters.

9 Specifications

9-1 Standard Specifications

Item		Specifications						
Inverter type		FVR0.1C11S-7	FVR0.2C11S-7	FVR0.4C11S-7	FVR0.75C11S-7	FVR1.5C11S-7	FVR2.2C11S-7	
Nominal applied motor ¹⁾ [kW]		0.1	0.2	0.4	0.75	1.5	2.2	
Output ratings	Rated output capacity ²⁾ [kVA]	0.26	0.53	0.95	1.5	2.6	3.8	
	Voltage [V]	<ul style="list-style-type: none"> 3-phase, 200V/50Hz, 200, 220, 230V/60Hz (Proportional to input voltage) 						
	Rated current [A]	0.7	1.4	2.5	4.0	7.0	10.0	
	Overload capacity	<ul style="list-style-type: none"> 150% of rated current for 1 min. 						
	Rated frequency	<ul style="list-style-type: none"> 50, 60Hz 						
Input power supply	Phases, Voltage, Frequency	<ul style="list-style-type: none"> Single-phase 200 to 240V 50/60Hz 						
	Voltage/frequency variations	<ul style="list-style-type: none"> Voltage: +10% to -10%, Frequency: +5% to -5% 						
	Capability for voltage dip ³⁾	<ul style="list-style-type: none"> When the input voltage drops 165V or more, the inverter can be operated continuously. When the input voltage drops below 165V from rated voltage, the inverter can be operated for 15ms. 						
	Rated input current ⁶⁾ [A]	(with DCR)	1.2	2.0	3.5	6.5	11.8	17.7
		(without DCR)	2.3	3.9	6.4	11.4	19.8	28.5
Required power supply capacity ⁴⁾ [kVA]	0.3	0.4	0.7	1.3	2.4	3.6		

Item		Specifications					
Braking	Braking torque ⁵⁾ [%]	150		100		50	30
	DC injection braking	<ul style="list-style-type: none"> Starting frequency: 3Hz (fixed), Braking current (0 to 100%), Braking time (0.0 to 30.0s) 					
Protective structure (IEC60529)		<ul style="list-style-type: none"> Closed type IP20 					
Cooling method		<ul style="list-style-type: none"> Self-cooling 			<ul style="list-style-type: none"> Fan cooling 		
Mass [kg]		0.6	0.6	0.7	0.9	1.6	2.2

Notes:

- 1) A 4-pole standard motor is assumed as a nominal applied motor.
- 2) Inverter output capacity (kVA) at 220V.
- 3) When a momentary power failure occurs, while rated voltage is applied 85% of load of nominal motor is given.
- 4) When an optional power-factor correcting DC reactor is used.
- 5) Average braking torque where an unloaded motor decelerates and stops from 60Hz operation. (Varies according to the motor efficiency)
- 6) The specification is calculated on assumption that the inverter is connected to a 500 kVA-equivalent power transformer.

9-2 Common Specifications

Item		Specifications	Remarks	
Output frequency	Setting	Maximum output frequency	<ul style="list-style-type: none"> 50 to 120Hz (in 1Hz steps) 	
		Base frequency	<ul style="list-style-type: none"> 50 to 120Hz (in 1Hz steps) 	
		Starting frequency	<ul style="list-style-type: none"> 1 to 6Hz (in 1Hz steps) 	
		Carrier frequency	<ul style="list-style-type: none"> 0.75 to 15kHz (Vector-distribution PWM control selectable at 7kHz or less) When operating at a carrier frequency of 9kHz or above, the frequency may automatically drop to 8kHz to protect the inverter. 	

Item		Specifications	Remarks
Output frequency	Accuracy	<ul style="list-style-type: none"> Analog setting: $\pm 1.0\%$ of maximum frequency (at $25 \pm 10^\circ\text{C}$) Keypad panel setting: $\pm 0.01\%$ of maximum frequency (at -10 to $+50^\circ\text{C}$) 	
	Setting resolution	<ul style="list-style-type: none"> Analog setting: 1/256 of Maximum frequency Keypad panel setting: 0.1Hz (99.9Hz or less), 1Hz (100Hz or more) 	
Control	Voltage/freq. Characteristic	<ul style="list-style-type: none"> Output voltage proportional to input voltage. Base frequency adjustable from 50 to 120Hz. 	
	Torque boost	<ul style="list-style-type: none"> Manual setting by code 0 to 31. (setting for variable torque load available) 	
	Starting torque	<ul style="list-style-type: none"> 150% or more (at 6Hz) 	
	Control method	<ul style="list-style-type: none"> Sinusoidal PWM control (with simplified current-vibration suppression) 	
	Operation method	<ul style="list-style-type: none"> Keypad operation: <input type="checkbox"/> RUN or <input type="checkbox"/> STOP key: Input signal: Forward/Reverse/Stop command, Coast-to-stop command, Trip command (External alarm), Alarm reset 	
	Frequency setting (Multistep) (Linked operation)	<ul style="list-style-type: none"> Keypad operation: Digital setting by <input type="checkbox"/> Δ or <input type="checkbox"/> ∇ key Built-in potentiometer Analog input: 0 to +5VDC, 0 to +10VDC, 4 to 20mADC Up to 4 multistep frequencies can be set in 2-bit external signal by terminal function selection Setting by RS485 serial communication (Option) 	
Acceleration/ deceleration time	<ul style="list-style-type: none"> 0.01 to 60.0s (Independently adjustable acceleration and deceleration) 		

Item		Specifications	Remarks
Control	Frequency limiter	<ul style="list-style-type: none"> High and low limits can be set for output frequency between 0 to 100% in Hz 	
	Bias frequency	<ul style="list-style-type: none"> The bias frequency can be set from -100 to +100% in Hz. 	
	Gain (frequency setting signal)	<ul style="list-style-type: none"> 5VDC or 10VDC gain can be selected. 	
	Frequency jump control	<ul style="list-style-type: none"> Jump frequency (3 points) and jump hysteresis width (1 point) can be preset. 	
	Restart after momentary power failure	<ul style="list-style-type: none"> Inverter restarts without causing inverter-trip when power supply recovers. 	
	PID control	<ul style="list-style-type: none"> PID control function is provided standard. 	
Enclosure (JEM 1030)		<ul style="list-style-type: none"> IP20 	
Cooling method		<ul style="list-style-type: none"> Natural cooling for 0.75kW or less. Fan cooling for 1.5kW or more. 	
Indication	Running, stopped	<ul style="list-style-type: none"> Output frequency, output current, and PID reference value/feedback value. The CRG lamp is on when the capacitor is charged. 	
	Program mode	<ul style="list-style-type: none"> Function code and data code 	

Item		Specifications	Remarks
Indication	Tripped	[Cause of trip by code] <ul style="list-style-type: none"> ● OC1 (Overcurrent: during acceleration) ● OC2 (Overcurrent: during deceleration) ● OC3 (Overcurrent: while running at constant speed) ● OU1 (Overvoltage: during acceleration) ● OU2 (Overvoltage: during deceleration) ● OU3 (Overvoltage: while running at constant speed) ● LU (Undervoltage) ● OH1 (Overheating: Heat sink) ● OH2 (Overheating: External alarm) ● OL (Overload: Motor) ● OLU (Overload: Inverter) ● Er1 (Memory error) ● Er3 (CPU error) ● Er8 (RS485 communication error) ● Lin (Input phase failure) 	
	Running, Tripped	<ul style="list-style-type: none"> ● Fault history data is stored and indicated for the past four trips. Data is retained while power is off. 	
Protection	Overload	<ul style="list-style-type: none"> ● Internal electronic thermal overload relay protects inverter overload. 	
	Overvoltage	<ul style="list-style-type: none"> ● Detect the excessive DC link circuit voltage to stop inverter. 	
	Overcurrent	<ul style="list-style-type: none"> ● Detect overcurrent due to overload on inverter output side to protect inverter 	
	Incoming surge	<ul style="list-style-type: none"> ● Detect incoming surge voltage between AC power and the earth to protect inverter. 	
	Undervoltage	<ul style="list-style-type: none"> ● Detect the DC link circuit undervoltage to stop inverter 	
	Overheating	<ul style="list-style-type: none"> ● Detects the cooling fan fault or abnormal temperature rise of inverter to protect inverter. 	
	Short-circuit	<ul style="list-style-type: none"> ● Detect overcurrent due to short-circuit on inverter output side to protect inverter. 	



Item		Specifications	Remarks
Protection	Ground fault	<ul style="list-style-type: none"> • Detects overcurrent due to ground fault on inverter output side to protect inverter. (Detect at starting) 	
	Motor protection	<ul style="list-style-type: none"> • Protect general-purpose motor or FUJI inverter motor with electronic thermal overload. 	
	Input phase failure protection (only for 3-phase 200V series)	<ul style="list-style-type: none"> • The inverter is protected against phase failure on the input side or over-current due to inter-phase imbalance. 	
	Stall prevention	<ul style="list-style-type: none"> • Controls frequency to prevent OC trip in case of the output current exceeds the limit value during acceleration. • Lowers the frequency to hold almost constant torque in case of the output current exceeds the limit value during constant speed running. • Controls frequency to prevent OU trip in case of the DC link circuit voltage exceeds the limit value during deceleration. 	
	Retry	<ul style="list-style-type: none"> • "Retry" function can be set for the protective functions OC1 to OC3 and OU1 to OU3. (No. of times of retry: 5, waiting time: 0.5s fixed.) 	
	Dielectric strength test	<ul style="list-style-type: none"> • At 2000Vac for 1 min. between any main circuit terminals and ground. (10mA or less) 	
	Megger test	<ul style="list-style-type: none"> • At 500VDC megger test between any main circuit terminals and ground (5MΩ or more) 	
Environment	Installation location	<ul style="list-style-type: none"> • Indoor use only. Do not install a dusty location (Degree of pollution: 2) or expose to direct sunlight, corrosive gases, flammable gases. 	
	Ambient temperature	<ul style="list-style-type: none"> • -10 to +50°C 	
	Ambient humidity	<ul style="list-style-type: none"> • 5 to 95% RH (No condensation) 	
	Altitude	<ul style="list-style-type: none"> • 1000 m or less 	

Item		Specifications	Remarks
Environment	Vibration	<ul style="list-style-type: none"> • 3 mm: 2 to less than 9 Hz • 9.8m/s²: 9 to less than 20 Hz • 2m/s²: 20 to less than 55 Hz • 1m/s²: 55 to less than 200 Hz 	
	Storage temperature	<ul style="list-style-type: none"> • -25 to +65°C 	
	Storage humidity	<ul style="list-style-type: none"> • 5 to 95% RH (No condensation) 	
Others	Higher harmonics current suppression	<ul style="list-style-type: none"> • Terminal for connecting power-factor correcting DC reactor (DCR) is provided as standard. 	P1, P(+) terminal
	Charging suppression resistor	<ul style="list-style-type: none"> • Charging suppression resistor is built-in for all inverter unit. 	
	Cooling fan ON/OFF control	<ul style="list-style-type: none"> • Cooling fan can be automatically stopped when inverter is stopped. 	

9-3 Dimensions

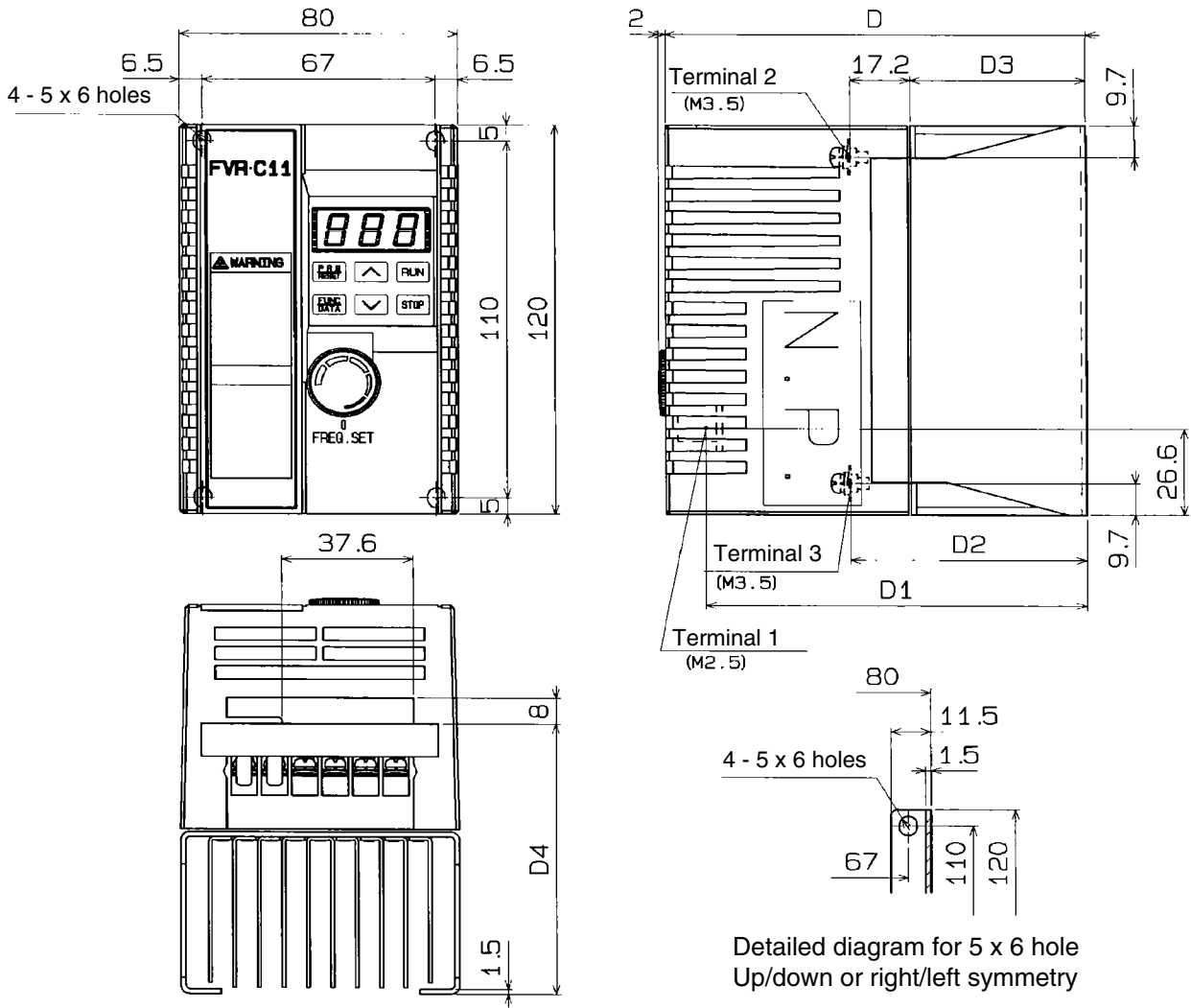

6

TERMINAL 1	30A	30B	30C	FM	X1	X2	X3	FWD	REV	P24/ CM	11	12	13	C1
------------	-----	-----	-----	----	----	----	----	-----	-----	------------	----	----	----	----

TERMINAL 2		L1/L		L2/N	P1	P(+)
------------	--	------	--	------	----	------

Single phase 200V series

TERMINAL 3	P(+)	N(-)	U	V	W	
------------	------	------	---	---	---	--

Series	Type	Nominal applied motor (kW)	Dimensions (mm)				
			D	D1	D2	D3	D4
Single phase 200V	FVR0.1C11S-7EN	0.1	80	68.5	27.2	10	43.2
	FVR0.2C11S-7EN	0.2	85	73.5	32.2	15	48.2
	FVR0.4C11S-7EN	0.4	115	103.5	42.2	25	58.2
	FVR0.75C11S-7EN	0.75	140	128.5	67.2	50	83.2

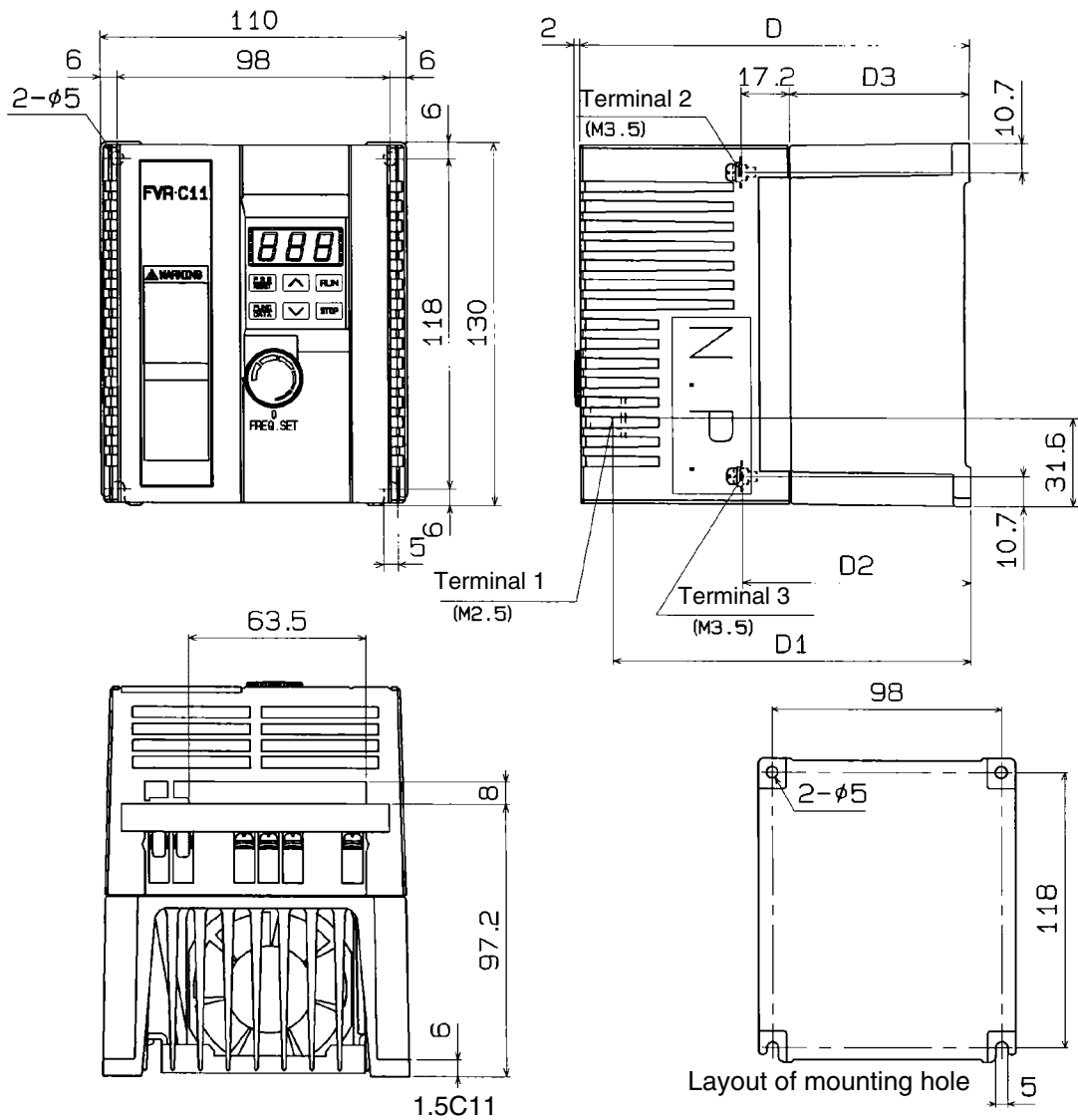

TERMINAL 1	30A	30B	30C	FM	X1	X2	X3	FWD	REV	P24/ CM	11	12	13	C1
------------	-----	-----	-----	----	----	----	----	-----	-----	------------	----	----	----	----

TERMINAL 2	G	L1/L		L2/N	P1	P(+)
------------	---	------	--	------	----	------

Single phase 200V series

TERMINAL 3	P(+)	N(-)	U	V	W	G
------------	------	------	---	---	---	---

Series	Type	Nominal applied motor (kW)	Dimensions (mm)			
			D	D1	D2	D3
Single phase 200V	FVR1.5C11S-7EN	1.5	149	137.5	81.2	64

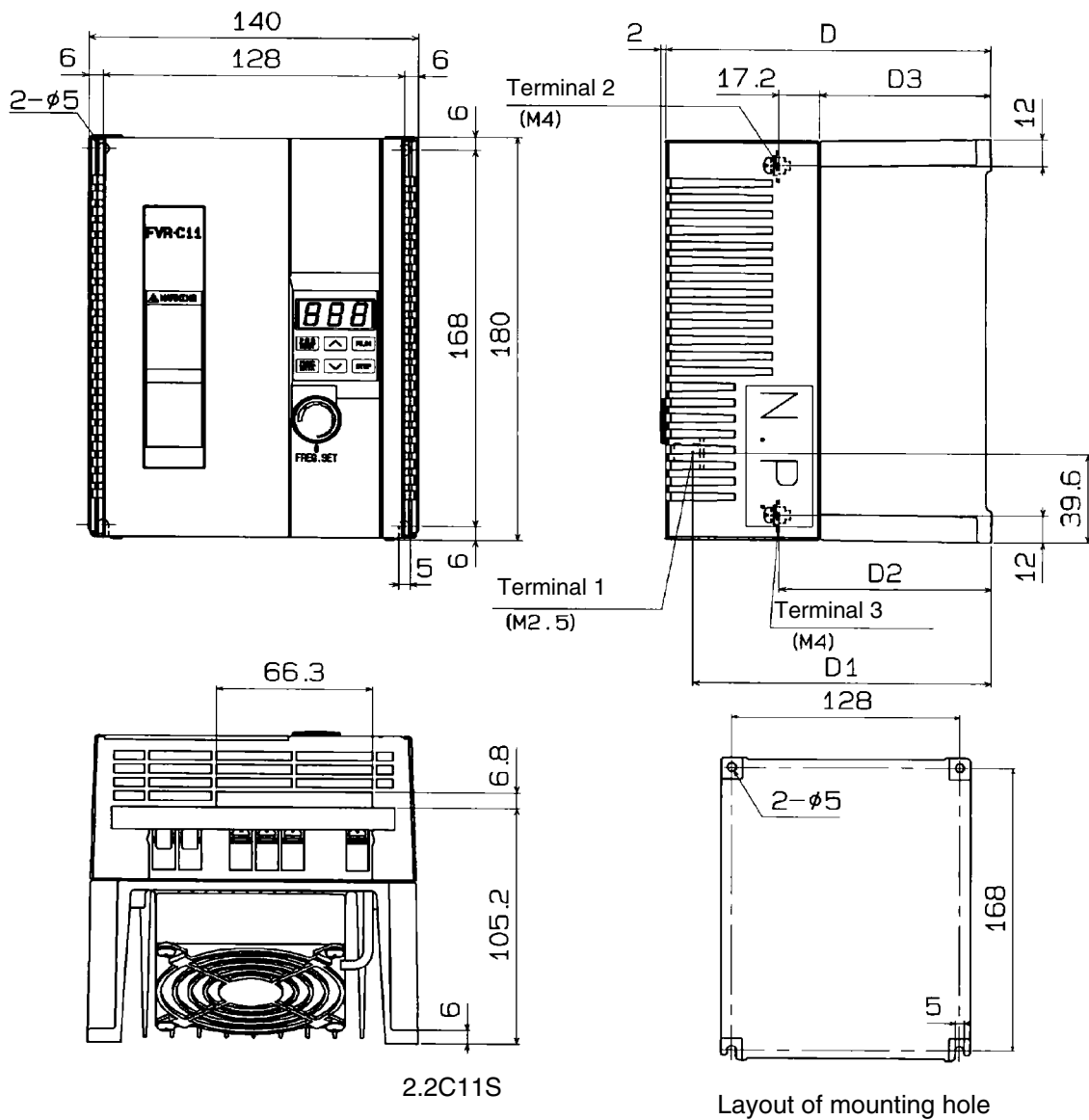

6

TERMINAL 1	30A	30B	30C	FM	X1	X2	X3	FWD	REV	P24/ CM	11	12	13	C1
------------	-----	-----	-----	----	----	----	----	-----	-----	------------	----	----	----	----

TERMINAL 2		L1/L		L2/N	P1	P(+)
------------	--	------	--	------	----	------

Single phase 200V series

TERMINAL 3	P(+)	N(-)	U	V	W	
------------	------	------	---	---	---	--

Series	Type	Nominal applied motor (kW)	Dimensions (mm)			
			D	D1	D2	D3
Single phase 200V	FVR2.2C11S-7EN	2.2	137	125.5	89.2	72

9-4 Selection of Peripheral Device

It is recommended to use a prescribed wire according to the EN60204 Appendix C.

Power supply voltage	Nominal applied motor (kW)	Inverter type	Molded case circuit breaker ¹⁾ (MCCB)		Magnetic contactor (MC)			Recommended wire size (mm ²)											
			Earth-leakage circuit breaker (ELCB or RCD) rated current (A)		Input circuit Single-phase 200V [L1/L, L2/N]		Output circuit [U,V,W]	Input circuit Single-phase 200V [L1/L, L2/N]		Output circuit ²⁾ [U,V,W]	DCR circuit ²⁾ [P1][P(+)]	Control wiring							
			Using with DCR.	Not using with reactor. ³⁾	Using with DCR.	Not using with reactor. ³⁾	Using with DCR.	Not using with reactor. ³⁾											
Single-phase 200V	0.1	FVR0.1C11S-7EN	6	6	SC-05			4)	2.5	4)	2.5	4)	2.5	0.5					
	0.2	FVR0.2C11S-7EN		10											16	4)	2.5	4)	2.5
	0.4	FVR0.4C11S-7EN		16											20				
	0.75	FVR0.75C11S-7EN	20	32				5)	5)	5)	5)								
	1.5	FVR1.5C11S-7EN						4.0	6.0	2.5	4.0								
	2.2	FVR2.2C11S-7EN			SC-5-1														

Table 9-4-1 Peripheral device selection

- 1) The frame size and the series for the applicable molded-case circuit breaker (MCCB) and earth-leakage circuit breaker (ELCB or RCD) differ according to the capacity of transformer in the facility. Refer to each technical document for details.
- 2) The recommended wire size in the main circuit is for when the ambient temperature is 40°C and conforming to LVD requirements. The wire size in () is minimum size for IV wire when no necessary of conforming to LVD.
- 3) Power supply impedance without a reactor must be 0.1% or equivalent by converting to the inverter capacity. Based on the voltage imbalance, a current imbalance of 10% is expected.
- 4) Crimp terminals up to 7.4mm in width (including tolerance) can be used.
- 5) Crimp terminals up to 9.5mm in width (including tolerance) can be used.



10 Options

10-1 Built-in Options

There is an optional built-in card for RS485 serial communication. Ask at the inverter distributor for details.

10-2 External Options

Molded case circuit breaker	The molded case circuit breaker (MCCB) is connected for protecting the main circuit wiring to the inverter and for turning power on and off. The rated current or the rated interrupting capacity varies according to the power supply specifications.
For input power-factor correcting AC reactor (ACR) DC reactor (DCR)	This is connected in the following cases. <ol style="list-style-type: none"> 1. When the power transformer capacity is more than 500 kVA 2. To reduce input harmonic current The input power factor is improved to 0.75 to 0.85 (ACR). The input power factor is improved to 0.9 to 0.95 (DCR). 3. If there is a thyristor load in the same power supply, if the capacitor for power-factor correcting is turned on or off, or if the surge voltage in the power supply is large (ACR only) * The DC reactor is unnecessary when the AC reactor is used.
Magnetic contactor (MC)	The inverter can be operated without connecting the magnetic contactor. When the inverter protective function is activated, this should be connected to turn off the power for safety.
Surge absorber	This is connected to suppress the surge generated by the exciting coil when switching on or off the magnetic contactor and the control relay. S2-A-0 (for magnetic contactor), S1-B-0 (for mini control relay)
Frequency setting POT (VR)	This is connected when the frequency is set from the control circuit terminal using inverter power.

Table 10-2-1 External Options

11 Applicable reactors

Applicable inverter type	Input power-factor correcting DC reactor (DCR)
FVR0.1C11S-7EN	DCR2-0.2
FVR0.2C11S-7EN	DCR2-0.4
FVR0.4C11S-7EN	DCR2-0.75
FVR0.75C11S-7EN	DCR2-1.5
FVR1.5C11S-7EN	DCR2-2.2
FVR2.2C11S-7EN	DCR2-3.7

Table 11-1-1 List of applicable reactors

Connection method

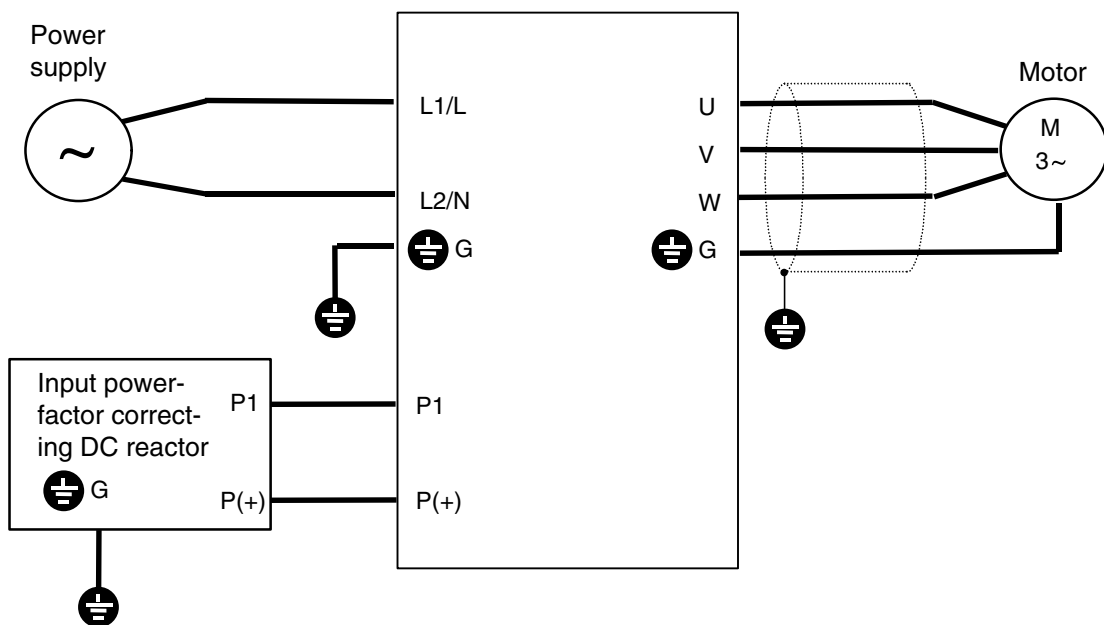

Fig. 11-1-1 Connection method of Input power-factor correcting DC reactor (DCR)

12 Compliance with standards

12-1 UL/cUL standards

[Applicable to products with UL/cUL mark]

12-1-1 General

The UL standards stand for Underwriters Laboratories Inc. and they are safety standards aiming at prevention of fire and other accidents in the United States, thereby providing protection for operators, service personnel and other persons.

The cUL standards are established by UL in the view of compliance with the CSA standards. The effect of products certified for the cUL standards is equal to that of products certified for the CSA standards.

12-1-2 Precautions

When using the UL/cUL certified product, refer to "Compliance with UL/cUL standards" on page 2.

For connection, refer to Fig. 12-1-1.

- Open Type Equipment "indoor use only"
- Suitable for use on a circuit capable or delivering not more than 5,000 rms symmetrical amperes, 240V maximum.
- When Protected by Class J Fuses.
- Use 60/75 C CU wire only.
- A Class 2 circuit wired with Class 1 wire.
- Field wiring connection must be made by a UL Listed and CSA Certified closed-loop terminal connector sized for the wire gauge involved. Connector must be fixed using the crimp tool specified by the connector manufacturer.
- Solid state motor overload protection is provided in each model.

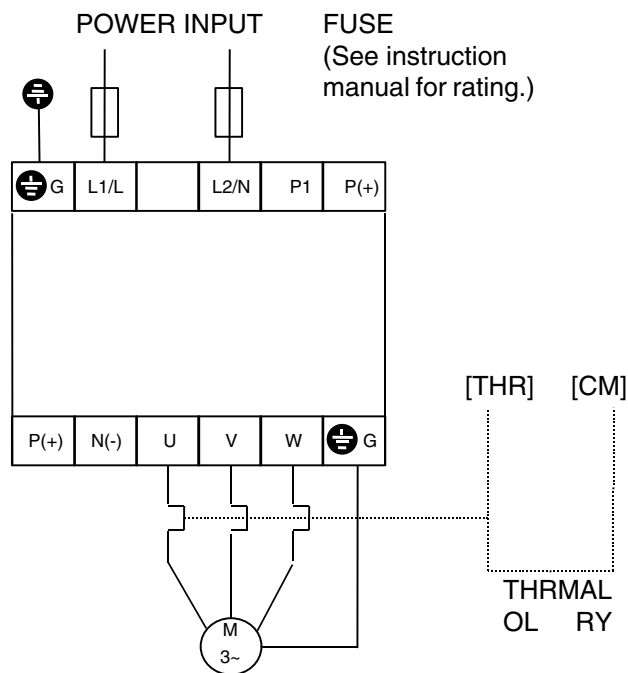

Fig. 12-1-1 Recommended wiring

12-2 Compliance with EMC directive in EU [Applicable to products with CE mark]

12-2-1 General

The CE mark indicated on the FVR-C11S series concerns with European minister directorate directive 89/336/EEC concerning the environmental electromagnetic compatibility EMC, and other directives are not included.

The CE mark does not prove that the entire machine or system housing our product complies with the EMC directive. Therefore indication of the CE mark to the entire machine or system will be done at the responsibility of the manufacturer or the machine. This is because:

1. The CE mark attached on our product supposes operation of the product under certain conditions. Satisfaction of the conditions is up to the manufacturer of the machine.
2. Generally speaking, various devices are used in a machine or system as well as our product. Therefore consideration for the entire machine or system must be paid by the manufacturer of the machine.

The EMC directive includes immunity to the incoming noise and emission of outgoing noise. The general purpose inverter houses an internal element switching at a high speed which generates electric noise.

Applicable standards

Immunity: EN 61800-3

Emission: EN 61800-3

Above-mentioned "certain conditions" include installation of a dedicated RFI filter in a metallic control panel.

Refer to in exclusive Instruction Manual for RFI Filter for details.

12-3 Compliance with low voltage directive in EU [Applicable to products with TÜV or CE mark]

12-3-1 General

The general purpose inverter is applicable for the low voltage directive in EU. Compliance of the FVR-C11S series with EN 50178/1997 has been obtained from a testing organization in EU and compliance with the low voltage directive is asserted.

12-3-2 Precautions

Refer to "Compliance with low voltage directive in EU" on pages 2 and 3 when using our product as one complying with the low voltage directive in EU.

13 Electromagnetic Compatibility (EMC)

13-1 General

In accordance with the provisions described in the European Commission Guidelines Document on Council Directive 89/336/EEC, Fuji Electric Co., Ltd. has chosen to classify the FVR-C11S range of Inverters as "Complex Components".

Classification as a "Complex Components" allows a product to be treated as an "apparatus", and thus permits compliance with the essential requirements of the EMC Directive to be demonstrated to both an integrator of FVR Inverters and to his customer or the installer and the user.

FVR Inverters is supplied 'CE-marked', signifying compliance with EC Directive 89/336/EEC when fitted with specified filter units installed and earthed in accordance with this sheet.

This Specification requires the following performance criteria to be met.

EMC product standard **EN61800-3/1996**

Immunity:

Second environment
(Industrial environment)

Emission:

First environment
(Domestic environment)

Finally, it is customer's responsibility to check whether the equipment conforms to EMC directive.

13-2 RFI Filters

It is strongly recommended that the appropriate FVR input filter is used, as shown in the followings, to limit RF current flowing into the main supply circuit.

Without an input filter a FVR installation may not meet statutory requirement. FVR Inverters contain high-power semi-conductor devices which are switched at high speeds to synthesize a near-sinusoidal current wave form across the frequency range of output.

Rapidly-changing voltages and currents will generate some degree of electromagnetic emission. Emissions will be predominantly conducted through the motor and the mains supply cables, although some radiated emissions will be detected in close proximity to the drive system.

It is essential that precautions are taken both at the design stage and at the time of installation to prevent radio frequency interference (RFI) from the drive system affecting sensitive equipment in close proximity.

The RFI filters range are designed especially for the FVR Inverter and help to ensure EMC compliance of machinery and installations using the Inverters.

The Inverters may be mounted on top of the filter using the integral fixing positions, the intention being that valuable space inside wiring cabinets may be saved. (Refer to Table 13-2-1)

Applied Inverter	Filter Type	Rated Current	Max. Rated Voltage	Dimensions LxWxH [mm]	Mount Dims Y x X [mm]	Wiring L' [mm]	Total ¹⁾ Weight [kg]	Inverter Fixings	Fig.
FVR0.1C11S-7EN FVR0.2C11S-7EN	EFL-0.2C11-7	4A	1ph 240Vac	180x86x38	155.5x60	125	Approx. 0.7	M4 x 12 (4)	Fig. 13-2-1
FVR0.4C11S-7EN FVR0.75C11S-7EN	EFL-0.75C11-7	12A		180x86x38	155.5x60	125	Approx. 0.7	M4 x 12 (4)	Fig. 13-2-1
FVR1.5C11S-7EN	EFL-1.5C11-7	20A		190x117x46	165x89	140	Approx. 1.2	M4 x 16 (4)	Fig. 13-2-2
FVR2.2C11S-7EN	EFL-2.2C11-7	29A		240x148x46	216x118	150	Approx. 1.5	M4 x 16 (4)	Fig. 13-2-2

Table 13-2-1 RFI filters Dimensions

Note: For detail, refer to the instruction manual that came with the RFI filters.

Remark: The EMC compliance tests have been carried out on the basis of the EN61800-3. Measurements were done with 50m motor cable (EN55011/ class A) and 10m motor cable (EN55011/ class B).

Remark: To minimize the conducted radio disturbance in the power distribution system, the length of motor cable should be as short as possible. And it is user's responsibility to confirm that the apparatus, which the inverters installed in, conforms to EMC directive when longer motor cable is used or other installation conditions are different from those described in this manual.

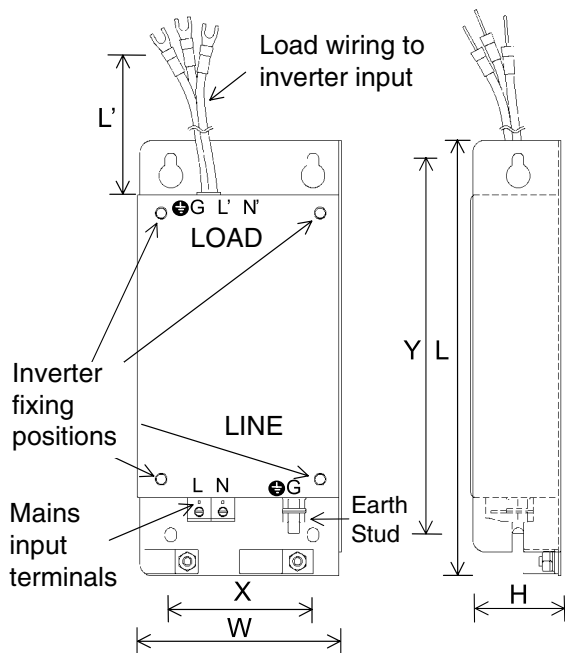

Fig. 13-2-1 RFI Filters

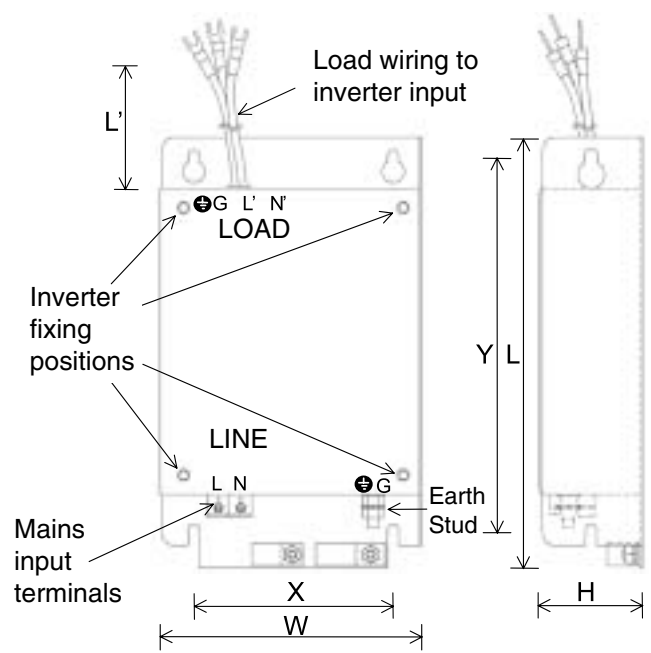

Fig. 13-2-2 RFI Filters

13-3 Recommended Installation Instructions

It is necessary that these instructions must be followed to conformed to EMC Directive. Follow the usual safety procedures when working with electrical equipment. All electrical connections to the filter, Inverter and motor must be made by a qualified electrical technician. (Refer to Fig. 13-3-1 and Fig. 13-3-2)

1. Use the correct filter according to Table 13-2-1.
2. Install the Inverter and filter in the electrically shielded metal wiring cabinet.
3. The back panel of the wiring cabinet of board should be prepared for the mounting dimensions of the filter. Care should be taken to remove any paint etc. from the mounting holes and face area of the panel. This will ensure the best possible earthing of the filter.
4. Use the screened cable for the control , motor and other main wiring which are connected to the Inverter, and these screens should be securely earthed.
5. It is important that all wire lengths are kept as short as possible and that incoming mains and outgoing motor cables are kept well separated.

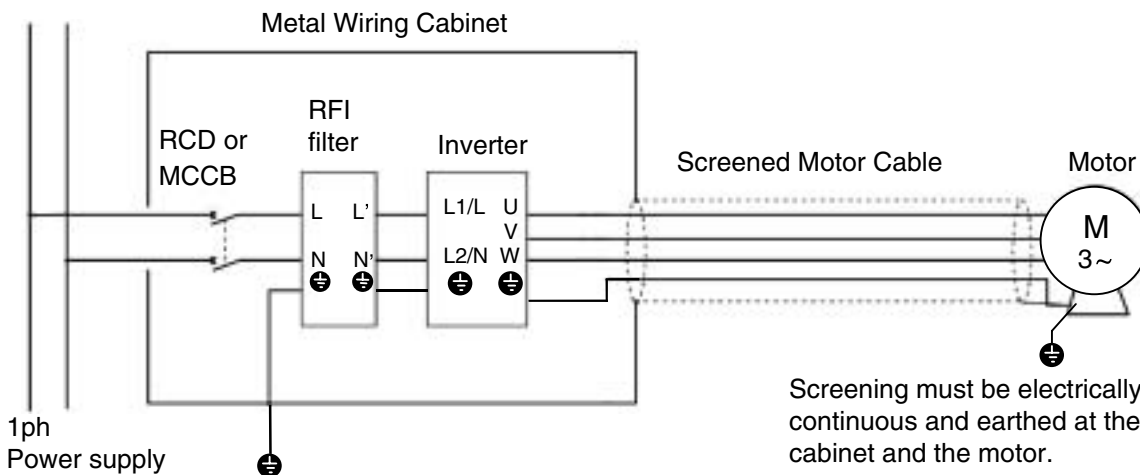

Fig. 13-3-1 Recommended Installation

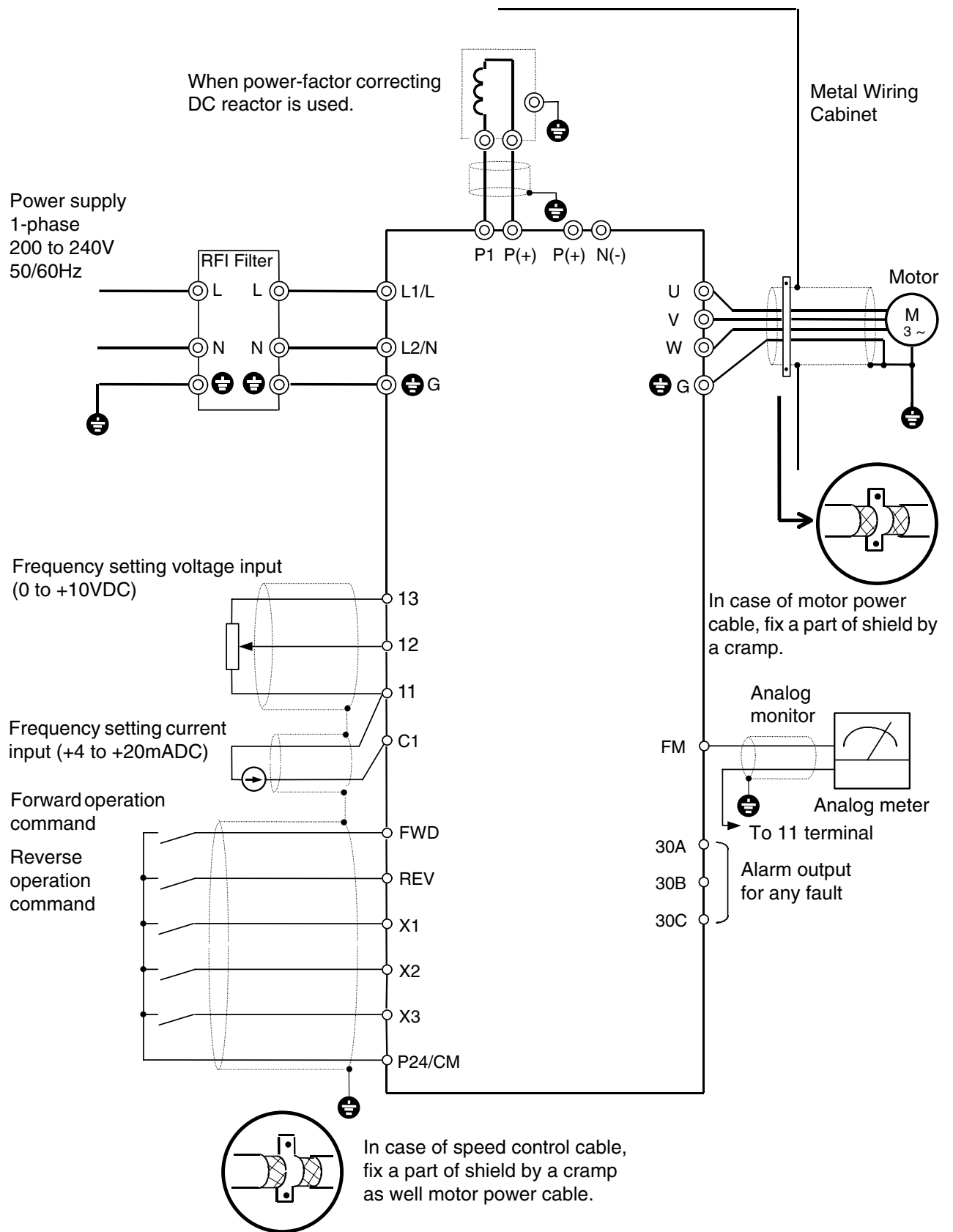

Fig. 13-3-2 Recommended installation detail inside the enclosure (SW7 set to P24)

European headquarter:

Fuji Electric GmbH
Lyoner Str. 26
D-60528 Frankfurt am Main
Tel.: +49-69-66 90 29-0
Fax: +49-69-66 90 29-58
e-mail: info_inverter@feg.fujielectric.com
Internet: <http://www.fujielectric.de>

Germany:

Fuji Electric GmbH
Head of sales
Lyoner Str. 26
60528 Frankfurt am Main
Tel.: +49-69-66 90 29-47
Fax: +49-69-66 90 29-58
pbrosch@feg.fujielectric.com

Fuji Electric GmbH
Sales area Südwest
Drosselweg 3
72666 Neckartailfingen
Tel.: +49-71 27-92 28 00
Fax: +49-71 27-92 28 01
hgneiting@feg.fujielectric.com

Fuji Electric GmbH
Sales area West
Dolmanstr. 46
51427 Bergisch Gladbach
Tel.: +49-22 04-96 03 88
Fax: +49-22 04-96 03 89
ffischer@feg.fujielectric.com

Fuji Electric GmbH
Sales area Mitte/Nord
Lyoner Str. 26
60528 Frankfurt am Main
Tel.: +49-69-66 90 29-47
Fax: +49-69-66 90 29-58

Switzerland

Fuji Electric GmbH
Zweigniederlassung
Altenrhein
IG-Park
CH-9423 Altenrhein
Tel.: +41-71-8 58 29 49
Fax: +41-71-8 58 29 40
info@fujielectric.ch

Italy

Fuji Electric GmbH
Centro Direzionale
Viale Colleoni 3, Taurus
I-20041 Agrate Brianza,
Milano
Tel.: +39-0 39-6 89 03 23
Fax: +39-0 39-6 89 04 46
fujiel@tin.it

Spain

Fuji Electric GmbH
Parc Tecnològic del
Vallés-Nr. 023
E-08290 Cerdanyola,
Barcelona
Tel.: +34-93-58 24-3 33/5
Fax: +34-93-58 24-3 44
jalemany@feg.fujielectric.com

France

Fuji Electric GmbH
PERIPARC
Immeuble "les NARCISSSES"
56, rue des Hautes Pâtures
F-92000 Nanterre, Paris
Tel.: +33-1-55 66 04-90
Fax: +33-1-55 66 04-99
mpages@feg.fujielectric.com

Specialised dealer