

Equipment for Special Machines
WF 705
Position Measuring Module

Description

Edition 11.96

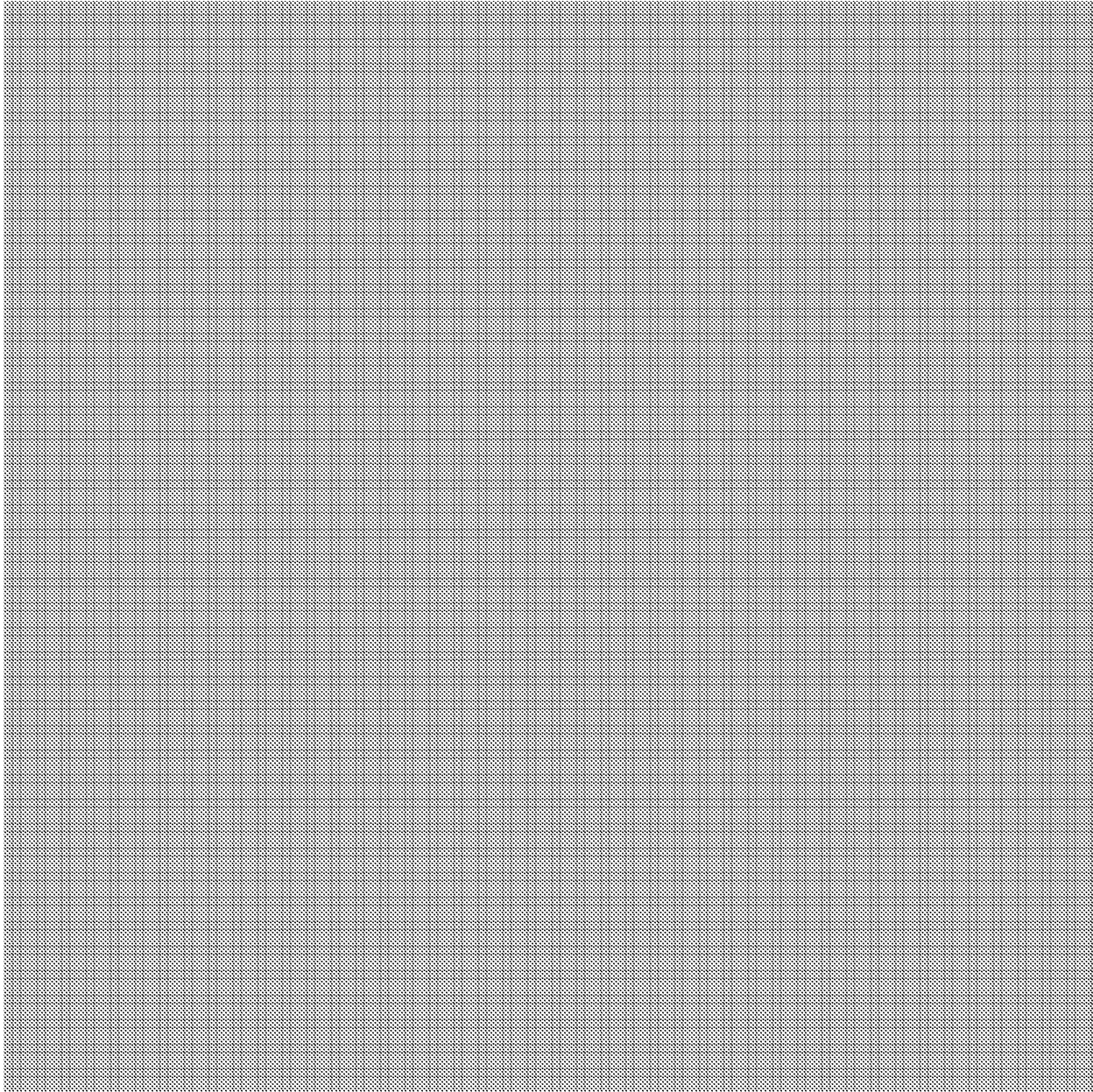

Overview 1

Configuration 2

WF 705

Position Measuring Module

Operation with SIMATIC S5 3

Description

Operation with
SIMATIC S7 - 400 4

Technical Data 5

EMV Recommendations 6

Ordering Data/
Documentation 7

Note

Because of clear arrangement, this documentation does not inform about all details of all types of the product. Therefore, it cannot take into account all possible cases of installations, operation and maintenance.

If you require additional information or have special questions, please seek further particulars from your local SIEMENS office.

The content of this documentation is not part of an earlier or existing agreement, acceptance or legal matter. All obligations by Siemens are set in the corresponding sales contract which also contains the complete and single valid settlement. The contract guarantee will not be enlarged or limited by this documentation.

BERO, SIMATIC, SIMODRIVE, SINEC, SINUMERIK, STEP are registered trade marks of Siemens.

The remaining designations contained in this "Description" may be trade marks whose use through third parties for their own purposes may infringe the rights of the owners of the mark.

Subject to technical changes.

The reproduction, transmission or use of this document or of its contents is not permitted without express written authority. Offenders will be liable for damages. All rights, including rights supplied by patent grant or registration of a utility model or design, are reserved.

© Siemens AG 1996 All Rights Reserved

Contents

1	Overview	1-1
1.1	Application	1-1
1.2	Characteristics of the WF 705	1-1
1.3	Data of the SSI Absolute Encoder	1-2
2	Configuration	2-1
2.1	Versions	2-1
2.1.1	Example with four Encoders on the WF 705	2-1
2.1.2	Example with twelve Encoders on the WF 705	2-1
2.1.3	Example with five Encoders on the WF 705	2-2
2.2	Configuration of the Actual Value Distributor	2-3
3	Operation with SIMATIC S5	3-1
3.1	Possible Slots for WF 705 in the SIMATIC S5 Rack	3-1
3.2	Functional Description	3-3
3.2.1	Function Block Numbers Dependent on the Type of AU	3-3
3.2.2	Start up	3-3
3.2.3	FB100/130/160: ANL-705	3-4
3.2.3.1	Description	3-4
3.2.3.2	Information about Application	3-4
3.2.3.3	Block Call	3-4
3.2.3.4	Block Parameters	3-5
3.2.4	Normal Operation (cyclical)	3-5
3.2.5	FB101/111/131/161: WEG-705	3-6
3.2.5.1	Description	3-6
3.2.5.2	Execution Times	3-6
3.2.5.3	Block Call	3-6
3.2.5.4	Block Parameters	3-6
3.2.5.5	Format of Parameters	3-7
3.2.6	Data Block Interface	3-8
3.3	Application Example for Position Measurement of 12 Axes ...	3-10
3.3.1	Initial Start and Restart	3-10
3.3.2	Cyclic, Time-Driven or Interrupt-Driven Execution	3-11

3.4	Commissioning/Trouble-Shooting	3-12
3.4.1	WF 705 Jumper and Switch Settings	3-12
3.4.1.1	Module Address (DPR Address)	3-13
3.4.1.2	Other Jumper Settings on the WF 705 Module	3-13
3.4.2	Jumper Settings on the Actual Value Distributor	3-14
3.4.3	Information about Trouble-Shooting	3-14
4	Operation with SIMATIC S7-400	4-1
4.1	Plugging the WF 705 in the SIMATIC S7-400 rack and in coupled SIMATIC S5 extension units	4-1
4.2	Functional Description	4-4
4.2.1	Possible CPU Types	4-4
4.2.2	Start up	4-4
4.2.3	FC100: ANL_705	4-5
4.2.3.1	Description	4-5
4.2.3.2	Information about Application	4-5
4.2.3.3	Block Call in OB 100	4-6
4.2.3.4	Block Parameters	4-7
4.2.4	Normal Operation (Cyclic)	4-8
4.2.5	FC100: WEG_705	4-8
4.2.5.1	Description	4-8
4.2.5.2	Execution Times	4-8
4.2.5.3	Block Call in OB 1	4-9
4.2.5.4	Block Parameters	4-9
4.2.5.5	Format of Parameters	4-10
4.2.6	Assignment of the DBBG Work Data Block	4-12
4.3	Example of Position Measuring	4-13
4.4	Addressing the WF 705 as SIMATIC S7-400 Periphery	4-13
4.4.1	Settings	4-14
4.4.2	Commissioning/Trouble-Shooting	4-16
4.4.2.1	WF 705 Jumper and Switch Settings	4-16
4.4.2.2	Jumper Settings on the Actual Value Distributor	4-17
4.4.2.3	Information about Trouble-Shooting	4-18
4.5	Multiprocessing	4-18

5	Technical Data	5-1
5.1	Characteristics of the Module	5-1
5.2	Connection of the Module	5-2
5.2.1	Overview of Cables and Devices	5-2
5.2.2	Pin Assignment of Front Connectors	5-3
5.2.3	Cable from WF 705 Module to SSI Absolute Encoder	5-4
5.2.4	Cable from Actual Value Distributor to SSI Absolute Encoder	5-5
5.2.5	Cable from WF 705 Module to Actual Value Distributor	5-6
6	EMV Recommendations	6-1
7	Ordering Data / Documentation	7-1

1 Overview

1.1 Application

In addition to positioning of closed loop servo axes, today's automated machines require position measurements of a number of axes.

The WF 705 position measuring module offers:

- Auxiliary axes
- Set up axes
- Handling and transportation functions
- Measuring functions

The WF 705 provides these functions in a space-saving and cost-effective way, compared to conventional solutions.

The WF 705 module can be used as a peripheral device in medium- and high-performance SIMATIC S5 PLCs (control versions S5-115U, S5-135U, S5-155U) and SIMATIC S7-400.

The WF 705 can measure up to 12 independent axes.

Up to 8 WF 705 modules can be used in one SIMATIC S5 PLC and this makes it possible to work with up to 96 axes.

1.2 Characteristics of the WF 705

- 12 axes per module
- Installation width
 - 1 SEP (SIMATIC S5)
 - 2 SEP in adapter casing (SIMATIC S7)
- Digital absolute position measurement with synchronous-serial data transfer
- Less cabling needed than with parallel-absolute position measurement
- Data format: Dual Code at transfer to SIMATIC S5/S7
- Interference-free data transfer: RS 422
- Settable transfer rate dependent on length of cabling
 - 1 Mbit/s: max. cable length 25 m
 - 125 Kbit/s: max. cable length 120 m
- Required peripheral address space per WF 705: 4 bytes
- Cable break and short circuit monitoring

1.3 Data of the SSI Absolute Encoder

- Gray code
- 125 Kbit/s to 1 Mbit/s transfer rate
- Possible number of steps per revolution at Standard SSI (pine-tree array):
 - 128
 - 256
 - 512
 - 1024
 - 2048
 - 4096
 - 8192
- Maximum of 4096 revolutions
- 25-bit data transfer format
- 24 V power supply voltage

2 Configuration

2.1 Versions

The serial-absolute encoders can either be connected directly to the WF 705 module or via the actual value distributor. If the encoders are connected directly to the WF 705, their 24V DC power supply is provided by the module.

2.1.1 Example with four Encoders on the WF 705

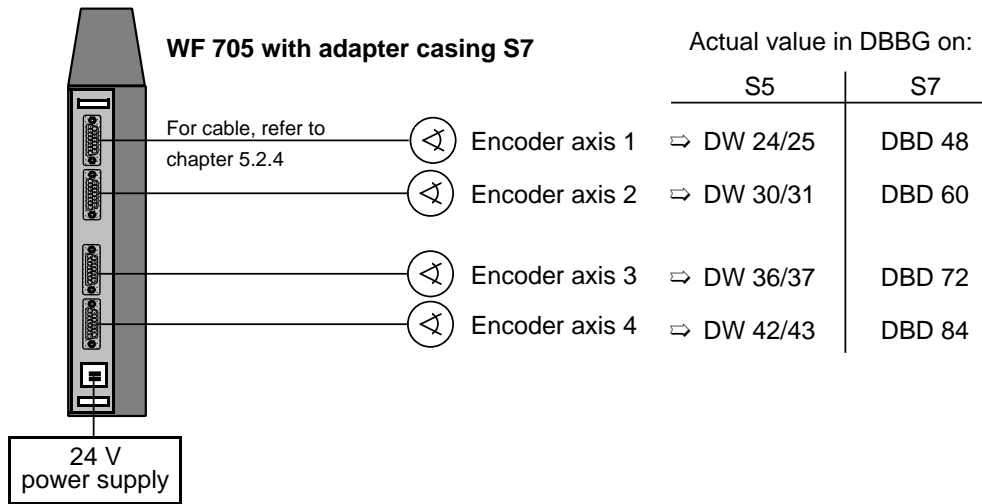

2.1.2 Example with twelve Encoders on the WF 705

If more than four axes have to be connected, then three axes are connected to one actual value distributor. The 24 V DC power supply for these encoders is fed through the actual value distributor.

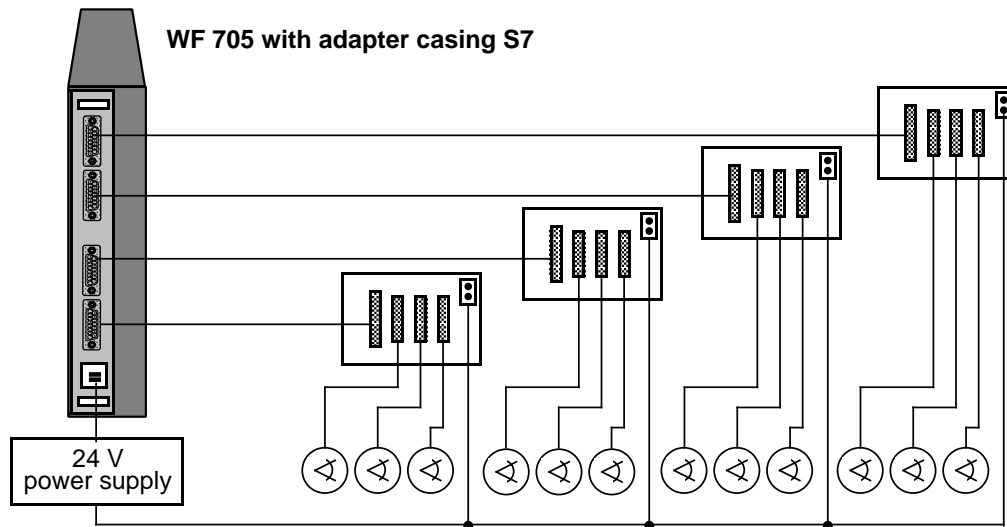

2.1.3 Example with five Encoders on the WF 705

Hybrid operation of directly connected encoders and encoders connected via the actual value distributor is possible. However, the power supply for those two versions must be the same (common ground).

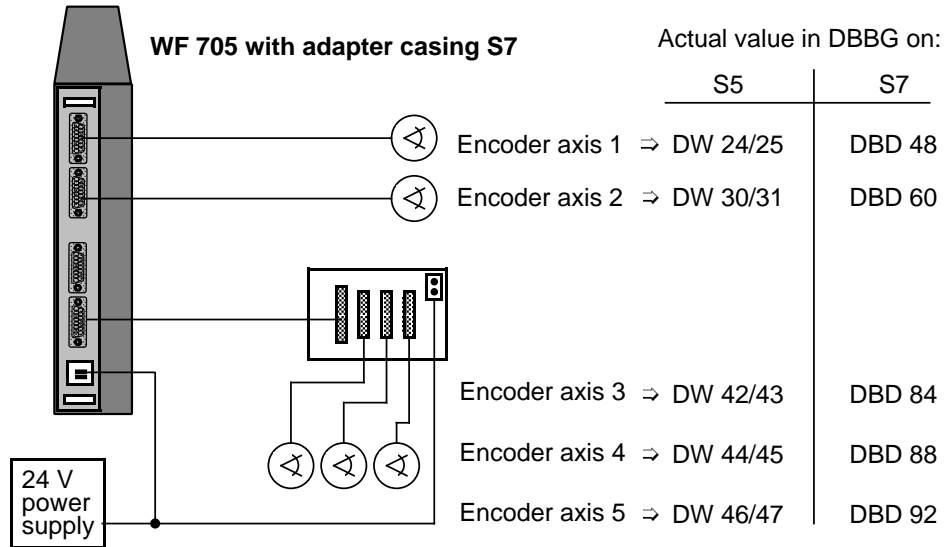

2.2 Configuration of the Actual Value Distributor

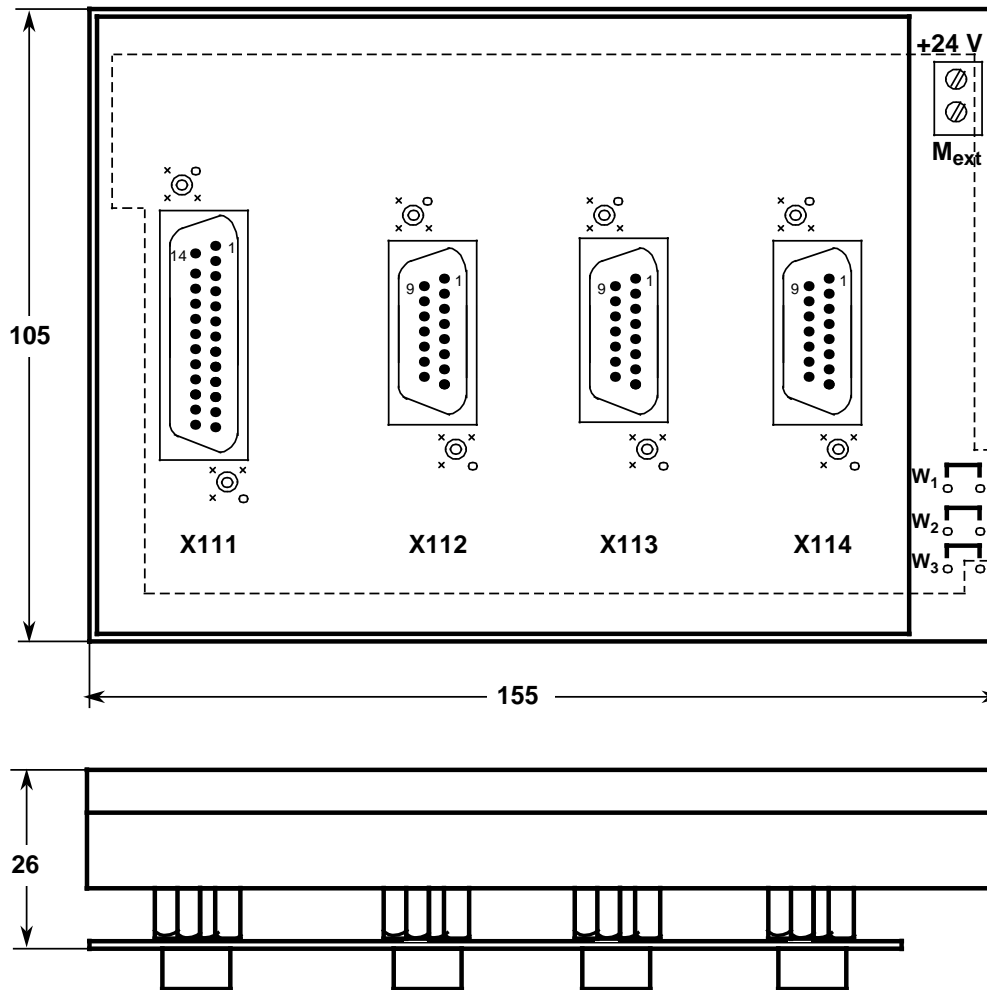

The actual value distributor transmits the clock pulses (CLK) arriving from the WF 705 on connector X111 via X112/X113/X114 to max. three encoders or transmits the signals (data) of max. 3 encoders via X112/X113/X114 to the connector X111 and thus to the WF 705.

3 Operation with SIMATIC S5

3.1 Possible Slots for WF 705 in the SIMATIC S5 Rack

It is not possible to use the WF 705 module in remote-linked extension racks (with IM 308/ IM 318). Each WF 705 module needs four address bytes in the peripheral area. The starting address must therefore be a multiple of four. Ensure that the maximum current of the power supply is not exceeded!

 Available slots are shaded grey.

Central unit S5-115U - subrack CR 700-0LA

Slot designation	PS	CPU	0	1	2	3	IM
WF 705							

Central unit S5-115U - subrack CR 700-0LB

Slot designation	PS	CPU	0	1	2	3	IM
WF 705							

Central unit S5-115U - subrack CR 700-1

Slot designation	PS	CPU	0	1	2	3	4	5	6	IM
WF 705										

Central unit S5-115U - subrack CR 700-2

Slot designation	PS	CPU	0	1	2	3	4	5	6	IM
WF 705										

Central unit S5-115U - subrack CR 700-3

Slot designation	PS	CPU	0	1	2	3	4	5	6	IM
WF 705										

Extension unit S5-115U - subrack ER 701-3

Slot designation	PS	0	1	2	3	4	5	6	7	IM
WF 705										

Central unit S5-135U / 155U

Slot designation	3	11	19	27	35	43	51	59	67	75	83	91	99	107	115	123	131	139	147	155	163	
WF 705																						

Extension unit EG-183U

Slot designation	3	11	19	27	35	43	51	59	67	75	83	91	99	107	115	123	131	139	147	155	163	
WF 705																						

Extension unit EG-185U

Slot designation	3	11	19	27	35	43	51	59	67	75	83	91	99	107	115	123	131	139	147	155	163	
WF 705																						

3.2 Functional Description

3.2.1 Function Block Numbers dependent on the Type of AU

Function Blocks	115 U 943B	115 U CPU 944B/945	135 U CPU 928B/948	155 U CPU 948
Start up	100	100	130	160
Position measurement	101	111	131	161
Set up	103	103	133	163

3.2.2 Start up

To save time during cyclic operation, certain functions are carried out or transferred once in the initial start routine.

The standard start up function block FB-ANL-705 needs the following parameters for initial starts and restarts:

- Data block number, DBBG, containing the actual position values
- Number of steps/revolution for each encoder
- Module address
- Baud rate for each encoder

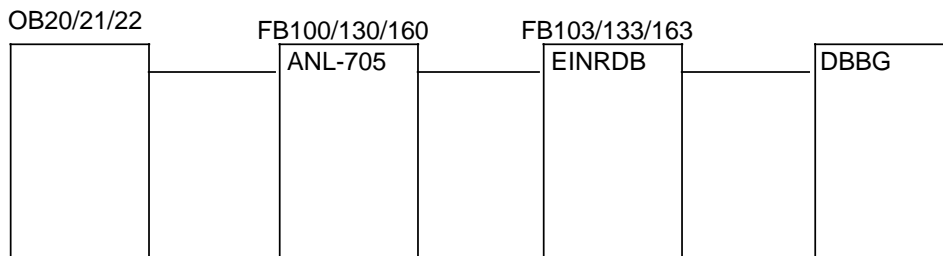

The DBBG data block provides the actual position values of the appropriate WF 705 module. This data block is generated automatically by function block FB 103 (EINRDB) with a length of 48 data words. During system start up, FB 103 is called in FB100/130/160 and checks if DBBG already exists and if it doesn't, it is generated.

The user can generate this data block himself and increase its length if he wants to, the user can then utilize the additional data words.

All the S5 blocks needed for installation are on the standard diskette.

3.2.3 FB100/130/160: ANL-705

3.2.3.1 Description

Depending on the CPU, FB100, FB130 or FB160 have to be called for start-up (see chapter 3.1). This block is used to preset the module after an initial start or a restart. It needs the number of steps per revolution for each encoder and a working data block for the actual position values. It checks whether the data block already exists, and if it doesn't it generates a 48 data word-long data block.

3.2.3.2 Information about Application

- Load FB 103/133/163; depending on S5-CPU (see chapter 3.1).
- The block must be called once for each module
- Each module needs one data block with a length of at least 48 data words
- Flags used: FYs 240–255

3.2.3.3 Block Call

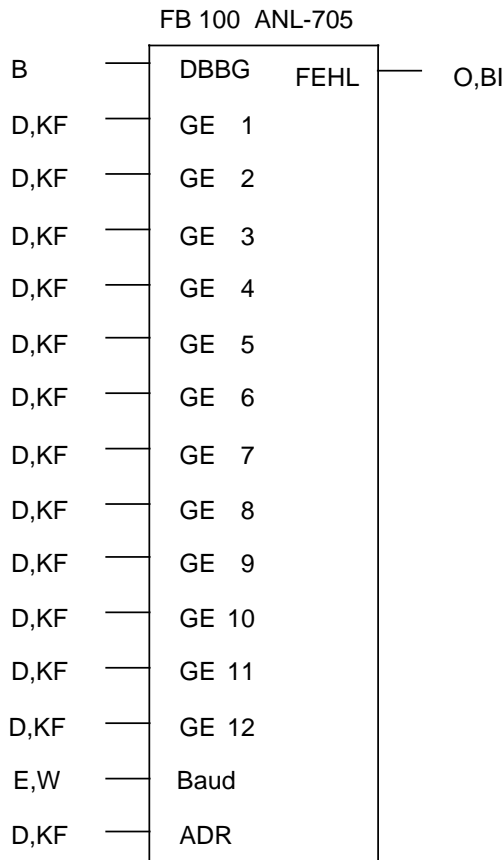

3.2.3.4 Block Parameters

DBBG Module data block

GE 1 Number of steps per revolution for axis 1
 ⋮ ⋮
 GE12 Number of steps per revolution for axis 12

The following values for steps/revolution can be entered:

4, 8, 16, 32, 64,	1024, 2048
128, 256, 512	4096, 8192

A zero must be entered for an axis which is not used. With programmable encoders, the number of steps per revolution can be set at the user's discretion. The value stated above which is in accordance with the programming must be entered in the parameter GE of the relevant axis as the function block is designed for the so-called „tree” format. Please ask the encoder manufacturer if you require further information.

BAUD Data transfer rate between encoder and WF 705 or actual value distributor

0: 125 Kbit/s up to a cable length of 120 m
 1: 1 Mbit/s up to a cable length of 25 m

See chapter 3.5.5 for the formats of the parameters.

ADR Address of the module: The value range is PB 4...252 and the value must be a multiple of 4 (see chapter 2.3, Possible slots).

FEHL This parameter is set if the DBBG cannot be generated, e.g because there is not enough available memory, or the wrong resolution has been selected, e.g. 500 instead of 512.

3.2.4 Normal Operation (cyclical)

The program reads out the actual position value of the desired axis if a request is made (single fetch). The program should be written in such a way that the actual values are made available to the user as quickly as possible. The actual values are stored in a data block (see data block interface).

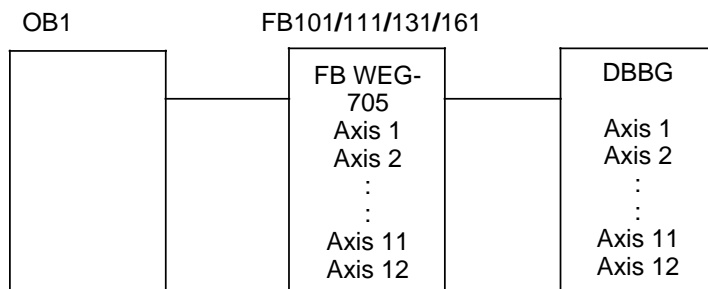

- The actual values are transferred in dual format to the user (refer to chapter 3.2.6).
- Code conversions (e.g.: dual BCD) have to be carried out by the user.
- The actual values are always read-out from the WF705 via a "single fetch".

3.2.5 FB101/111/131/161: WEG-705

3.2.5.1 Description

Depending on the CPU, FB101, FB111, FB131, FB161 have to be called for position measurement (see chapter 3.1). This block reads out the actual position values of up to 12 axes. The requested actual values are available in DBBG DW24...47 (see chapter 3.2.5, data block interface) once execution of the FB is finished.

3.2.5.2 Execution Times

CPU	Block	Duration of FB call [ms]	Running time per channel [ms]	Example: Running time for 3 channels [ms]
CPU 943B	FB101	2.61	3.69	3×3.69+2.61
CPU 944B	FB111	0.3	0.4	3×0.4+0.3
CPU 945	FB111	0.025	0.275	3×0.275+0.025
CPU 928B	FB131	0.33	0.37	3×0.37+0.33
CPU 948	FB161	0.11	0.29	3×0.29+0.11

- FBs to be loaded: FB100, FB103 (for start up)
- The block must be called once for each module.
- The user has to enter the DB No. and the axis No.
- Used flags: none

3.2.5.3 Block Call

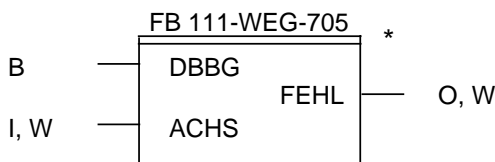

* The parameters are not shown with designators if CPU 943B is used.

In this case, the parameters are assigned via a flag interface to save cycle time.

3.2.5.4 Block Parameters

DBBG	Module DB	MB 229
ACHS	Number of the axis between 1 and 12 for which the actual values FW230 are to be read-out (DUAL).	FW 230
FEHL	This parameter signals a break or a short-circuit in the cable, wrong parameter assignment or wrong axis selection.	FW 242

3.2.5.5 Format of Parameters

ACHS Parameter

Data words are not permitted

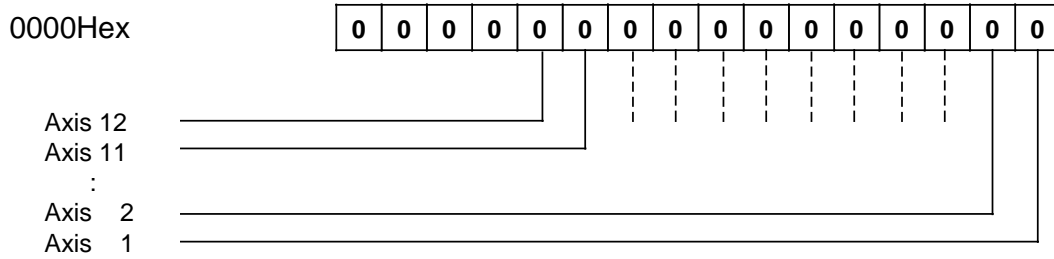

Example:

The actual position values of axes 1,2,3,4 and 12 are to be read-out:



FEHL Parameter

Data words are not permitted

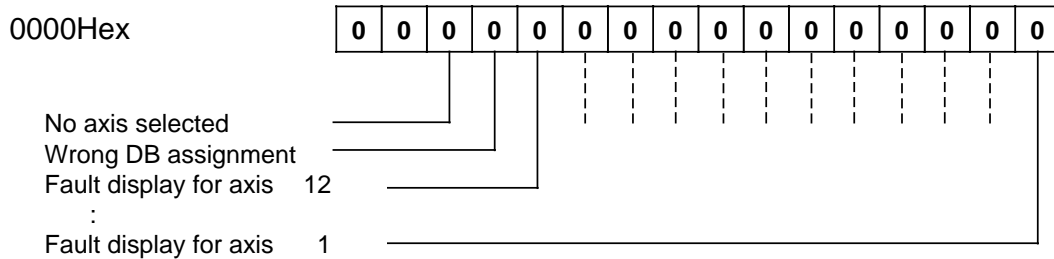

Example:

A fault is signalled for axis 2

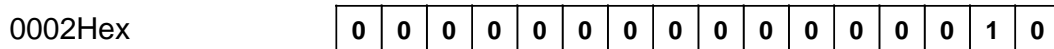

BAUD Parameter

Data words are not permitted

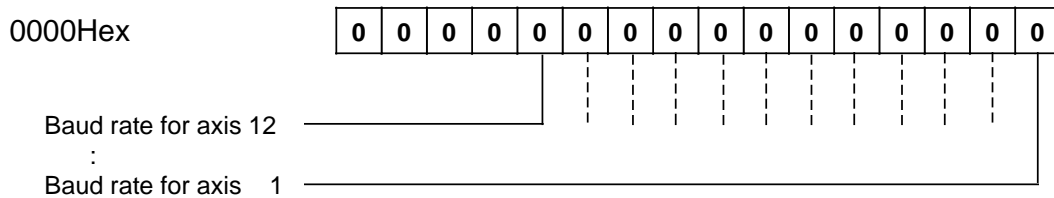

Example:

The actual values of axes 3 and 12 are to be read-out at 1 Mbit/s (25m cable) and axes 1, 2 and 4 are to be read-out at 125 Kbit/s (120m cable). The bit is only evaluated for axes which have been selected in the ACHS parameter.

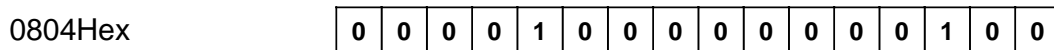

3.2.6 Data Block Interface

If the DBBG data block module does not exist yet, then it is generated 48 data words long during an initial start or a restart. It is also possible to generate DBBG more than 48 data words long. The data words above 48 would then be available to the user.

DW0..23	Used internally or reserved	
DW24	Actual position value of axis 1	High
DW25	Actual position value of axis 1	Low
DW26	Actual position value of axis 2	High
DW27	Actual position value of axis 2	Low
DW28	Actual position value of axis 3	High
DW29	Actual position value of axis 3	Low
DW30	Actual position value of axis 4	High
DW31	Actual position value of axis 4	Low
DW32	Actual position value of axis 5	High
DW33	Actual position value of axis 5	Low
DW34	Actual position value of axis 6	High
DW35	Actual position value of axis 6	Low
DW36	Actual position value of axis 7	High
DW37	Actual position value of axis 7	Low
DW38	Actual position value of axis 8	High
DW39	Actual position value of axis 8	Low
DW40	Actual position value of axis 9	High
DW41	Actual position value of axis 9	Low
DW42	Actual position value of axis 10	High
DW43	Actual position value of axis 10	Low
DW44	Actual position value of axis 11	High
DW45	Actual position value of axis 11	Low
DW46	Actual position value of axis 12	High
DW47	Actual position value of axis 12	Low

Data format of the actual value, e.g. for axis 1

DW24	0	0	0	0	0	0	0	2^{24}	2^{23}							2^{16}
DW25	2^{15}															2^0

The highest possible value from the encoder is $2^{25}-1=33554431$

3.3.2 Cyclic, Time-Driven or Interrupt-Driven Execution

OB1, OB2, OB3, SPRM-A LAE=7 ABS
PAGE 1

SEGMENT 1
0000 : JU PB1
0001 : BE

PB1 SPRM-A LAE=14 ABS
PAGE 1

SEGMENT 1
0000 : L KH 0FFF read out all 12 axes
0001 : T FW120
0002 : JU FB111
0003 NAME : WEG-705
0004 DBBG : DB100
0005 ACHS : FW120
0006 FEHL : FW124
0007
0008 : BE

3.4 Commissioning/Trouble-Shooting

3.4.1 WF 705 Jumper and Switch Settings

WF 705

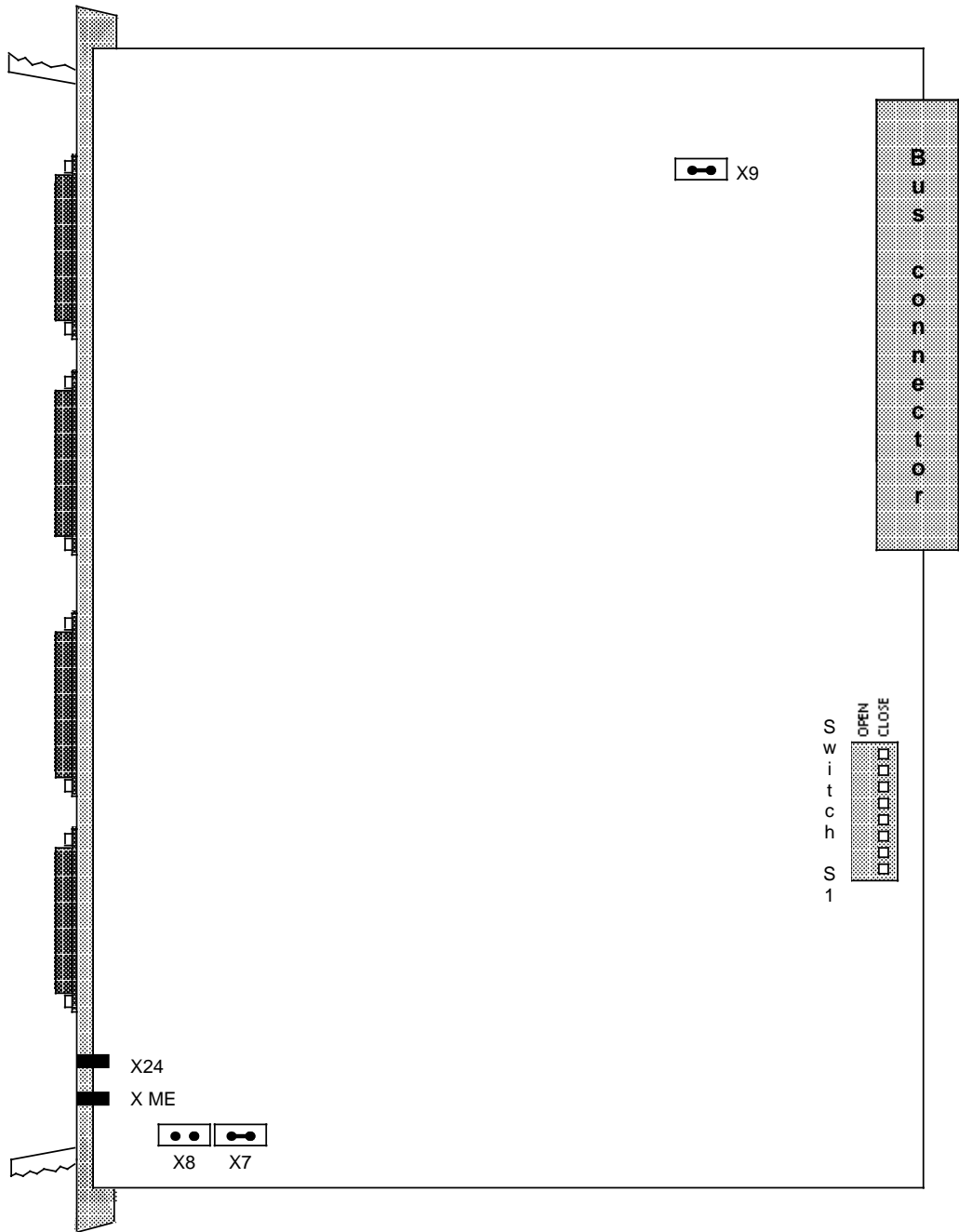

3.4.1.1 Module Address (DPR Address)

Switch S 1

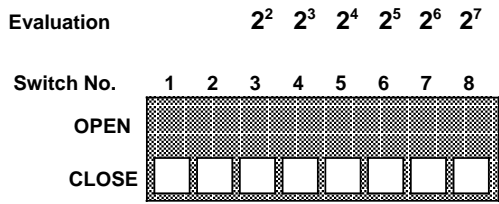

The actual position of the switch is marked white

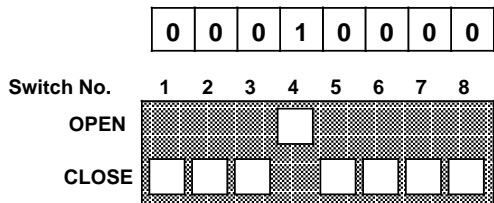

Example 1: Address 8



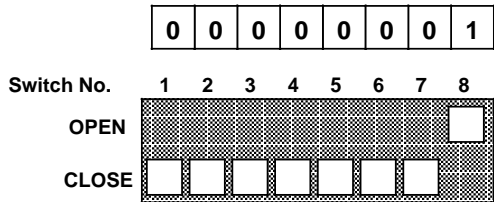



Example 2: Address 128



3.4.1.2 Other Jumper Settings on the WF 705 Module:





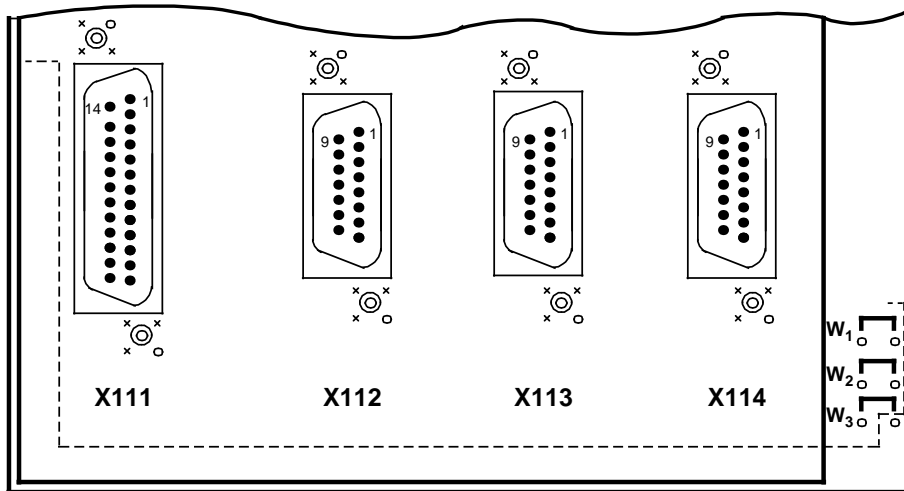

Jumper X7:  CLOSE External ground: 5 V ground connected to 24V ground (state on delivery)
 OPEN External ground: 5 V ground not connected to 24V ground

Jumper X8:  OPEN 5V ground connected to screen via plug housing and wiper of the SIMATIC S5 (state on delivery)
 CLOSE see OFF but additionally connected to ground of X6

Jumper X9:  CLOSE
 OPEN For testing: Interrupts the clock line (used in factory only)

3.4.2 Jumper Settings on the Actual Value Distributor:



- | | | | |
|-------------------|---|-------|--|
| Jumper W1: |  | CLOSE | Screen with external ground
(No function in WF 705) |
| |  | OPEN | |
| <hr/> | | | |
| Jumper W2: |  | CLOSE | Connection of external 24V ground to WF 705 module |
| |  | OPEN | |
| <hr/> | | | |
| Jumper W3: |  | CLOSE | (No function in WF 705) |
| |  | OPEN | |

3.4.3 Information about Trouble-Shooting

Please check the following items:

- Is the address set on the module the same as the one parameterized in FB100?
- Is the 24V DC power supply for the encoders connected to the actual value distributor and/or connected directly to the WF 705 module?
- If no position values are read-out for certain axes or if the values do not change when the encoder is turned by hand, e.g. 1AAA AAAA or 003A AAA5, check the following:
 - whether a read-out has been requested for the axes in question;
 - whether the cable break monitor has been triggered;
 - whether an encoder has been connected for that axis;
 - whether the cable has been connected correctly. If necessary, change the connector.
- whether jumpers X7 are open except for one module?
- whether jumpers X8 are open and the encoder cables's screens are generously grounded (see chapter 4.3)

4 Operation with SIMATIC S7-400

4.1 Plugging the WF 705 in the SIMATIC S7-400 rack and in coupled SIMATIC S5 extension units

The WF 705 module can be used in the SIMATIC S7-400 in different ways:

- In SIMATIC S7-400 central units by means of SIMATIC S5 adapter casing
- In SIMATIC S5 extension units by means of interfaces IM463-2 and IM314



For plugging the WF 705 module in the subrack of the SIMATIC S7-400, a WF 705 with adapter casing can be ordered. Two slots are required in the SIMATIC S7.

Possible S7-400 central units:

Central unit S7-400 - subrack UR1

Slot designation	1	2	3	4	5	6	7	8	9	10	11	12	13	14	15	16	17	18
PS																		
CPU																		
WF 705 with AC ¹⁾																		
IM 463-2																		

Central unit S7-400 - subrack UR2

Slot designation	1	2	3	4	5	6	7	8	9
PS									
CPU									
WF 705 with AC ²⁾									
IM 463-2									

- PS: Power supply may occupy 1, 2 or 3 slots, depending on version
- CPU: May occupy 1 or 2 slots, depending on version
- WF 705 with AC: The adapter casing occupies 2 slots (current consumption: 500 mA)
- IM 463-2: Occupies 1 slot (data see catalog ST 70)
- 1) Up to 8 modules (adapter casings) can be plugged
- 2) Up to 3 modules (adapter casings) can be plugged

Possible SIMATIC S5 extension units with receiver IM 314:

- ER 701-3 (SIMATIC S5-115U)
- EG 183U/-185U (SIMATIC S5-135U/-155U)

Extension unit S5-115U - subrack ER 701-3

Slot designation	PS	0	1	2	3	4	5	6	7	IM
Power supply										
IM 306										
IM 314										
WF 705										

Extension unit S5-183U

Slot designation	3	11	19	27	35	43	51	59	67	75	83	91	99	107	115	123	131	139	147	155	163	
IM 314																						
WF 705																						

Extension unit 185U

Slot designation	3	11	19	27	35	43	51	59	67	75	83	91	99	107	115	123	131	139	147	155	163	
IM 314																						
WF 705																						

4.2 Functional Description

4.2.1 Possible CPU Types

Automation unit	CPU type	Order No.
S7-400	412-1	6ES7 412-1XF00-0AB0
	413-1	6ES7 413-1XG00-0AB0
	413-2DP	6ES7 413-2XG00-0AB0
	414-1	6ES7 414-1XG00-0AB0
	414-2DP	6ES7 414-2XG00-0AB0
	416-1	6ES7 416-1XG00-0AB0

4.2.2 Start up

To save time during cyclic operation, certain functions and parameters are pre-assigned in the work data block or transferred once in the initial start or restart routine.

In case of restart, the program continues at the point of interruption in the cycle. The WF 705 cannot restart, i.e. when used in the SIMATIC S7-400, an "automatic restart" is not admissible, but an "automatic initial start".

The FC100:ANL_705 block needs the following parameters for initial starts and restarts:

- Data block number DBBG, containing the actual position values
- Number of steps/revolution for each encoder
- Module address
- Baud rate for each encoder

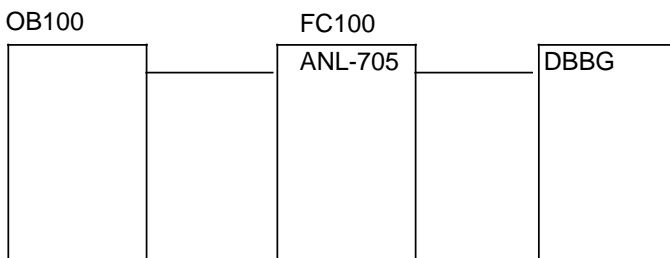

The DBBG data block provides the read-out actual position values of the appropriate WF 705 module. This data block is generated automatically by the FC100 block with 100 bytes unless it exists already.

The user can generate the DBBG himself and increase its length if he wants to; the user can then utilize the additional data words.

All S7 blocks needed for installation are on the standard diskette.

4.2.3 FC100: ANL_705

Block for initial start, restart and generation of the work data block of the WF 705.

4.2.3.1 Description

This block is used to preset the module after an initial start or a restart. It needs the following specifications:

- Data block number of the work data block DBBG containing the actual position values
- Number of steps/revolutions for up to 12 encoders
- Module address
- Baud rate for each encoder

The block checks whether a work data block already exists and whether it is long enough. The work data block will automatically be generated with a length of 100 bytes unless it exists already.

4.2.3.2 Information about Application

- Block call
 - only in the start-up OB's
 - once for each module
- Behaviour in case of fault

The FC100:ANL_705 will bring the CPU into STOP status in a defined way if:

 - a fault occurs upon set-up of the work data block
 - the module address is not divisible by 4

The reason of the faults is stored in Akku1.

4.2.3.3 Block Call in OB 100

KOP representation

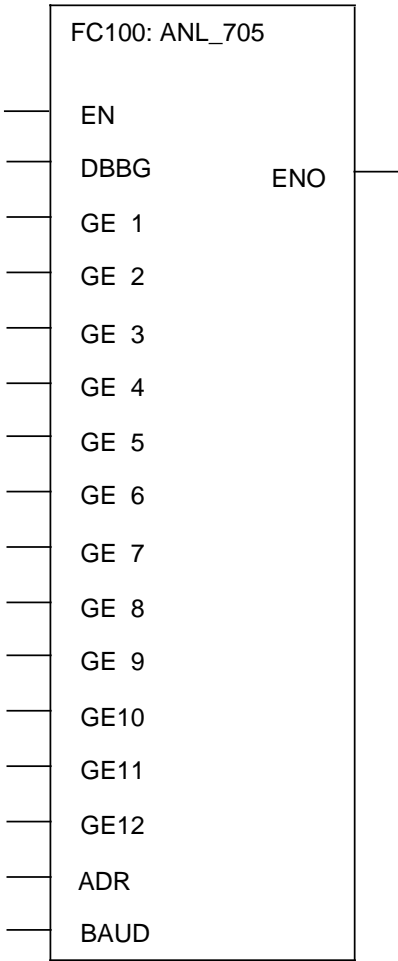

4.2.3.4 Block Parameters

Name	Type	Data type	Comment	Admissible assignment, remark
DBBG	INPUT	BLOCK_DB	Work data block	CPU specific
GE_1	INPUT	INT	No. of steps per revolution for axis 1	0 Axis is not used 1 2 4 8 16 32 64 128 256 512 1024 2048 4096 8192
GE_2	INPUT	INT	No. of steps per revolution for axis 2	
GE_3	INPUT	INT	No. of steps per revolution for axis 3	
GE_4	INPUT	INT	No. of steps per revolution for axis 4	
GE_5	INPUT	INT	No. of steps per revolution for axis 5	
GE_6	INPUT	INT	No. of steps per revolution for axis 6	
GE_7	INPUT	INT	No. of steps per revolution for axis 7	
GE_8	INPUT	INT	No. of steps per revolution for axis 8	
GE_9	INPUT	INT	No. of steps per revolution for axis 9	
GE_10	INPUT	INT	No. of steps per revolution for axis 10	
GE_11	INPUT	INT	No. of steps per revolution for axis 11	
GE_12	INPUT	INT	No. of steps per revolution for axis 12	
ADR	INPUT	INT	Module address	divisible by 4
BAUD	INPUT	WORD	Baud rate for axis 1 • • • 12	Bit 0 0: 125 Kbit/s up to max. 120 m Bit 11 1: 1 Mbit/s up to max. 25 m
EN	INPUT		Block enable	1
ENO	OUT-PUT		Block was processed (see following remark)	1



EN/ENO mechanism:

The binary result BIE, and thus ENO, is set to "1" if the block was terminated without fault. If a fault occurs, the binary result BIE, and thus ENO, will be set to "0".

4.2.4 Normal Operation (cyclic)

Only if a request is made (single fetch) will the program read out the actual position values of the desired axis. The program should be written in such a way that the actual values are made available to the user as quickly as possible. The actual values are stored in the DBBG data block.

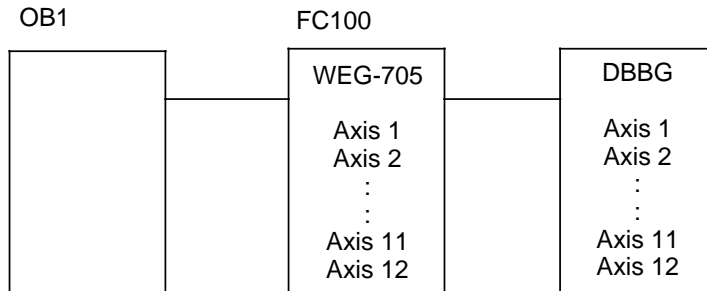

- The actual value are transferred in dual format to the user (refer to chapter 3.2.6).
- Code conversions (e. g.: dual BCD) have to be carried out by the user.
- The actual values are always read out from the WF 705 via "single fetch".

4.2.5 FC100: WEG_705

This block reads out the actual position values of axes 1 to 12 for the WF 705 position measuring module.

4.2.5.1 Description

The FC100:WEG_705 block reads out the actual position values of up to 12 axes. The requested actual values are available in the work data block in dual code once the execution of the FC is finished. The block does not carry out code conversions. Therefore, the same encoder specifications as for operation with SIMATIC S5 are valid, namely:

- 25-bit telegram
- 125 Kbit/s/1 Mbit/s
- Gray-Code
- Pine-tree format

4.2.5.2 Execution Times

Block	Duration of FC call [ms]	Duration for one encoder request [ms]	Example: running time for 3 channels, complete [ms]
FC100:WEG_705	1.04	0.445	1.04 + 3 × 0.445

4.2.5.3 Block Call in OB 1

KOP representation

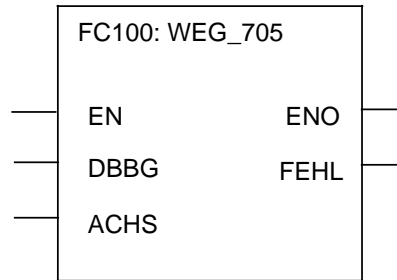

4.2.5.4 Block Parameters

Name	Type	Data type	Comment	Admissible assignment, remark
DBBG	INPUT	BLOCK_DB	Work data block	CPU-specific
ACHS	INPUT	WORD	No. of the axis between 1 and 12 for which the actual value is to be read out	Selection of: Bit 0 ⇒ Axis 1 ⋮ Bit 11 ⇒ Axis 12
FEHL	OUTPUT	WORD	Fault display	Bit 0 ⇒ Axis 1 ⋮ Bit 11 ⇒ Axis 12 Bit 12 ⇒ DB does not exist Bit 13 ⇒ No axis selected Bit 14 ⇒ DB is write-protected Bit 15 ⇒ CB is too short

4.2.5.5 Format of Parameters

ACHS parameter

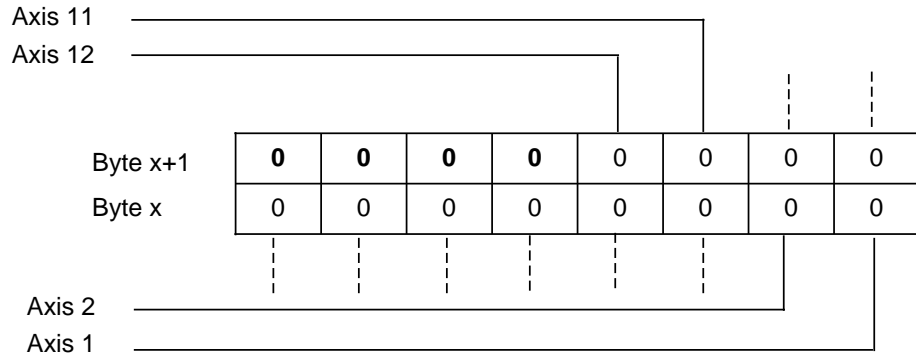

Example:

Axis 1, 2, 3, 4 and 12 are to be read out.

080F _{Hex}	Byte x+1	0	0	0	0	1	0	0	0
	Byte x	0	0	0	0	1	1	1	1

FEHL parameter

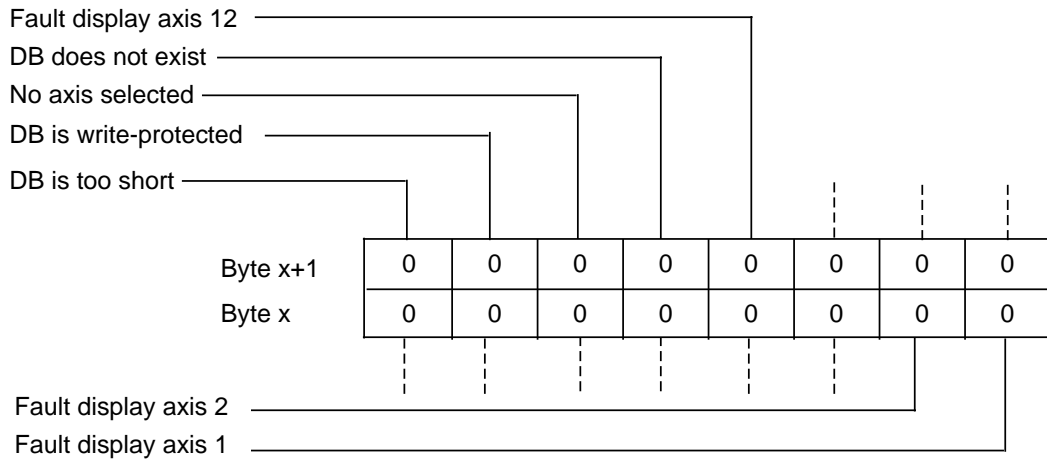

Example:

A fault is signalled for axis 2.

0002 _{Hex}	Byte x+1	0	0	0	0	0	0	0	0
	Byte x	0	0	0	0	0	0	1	0

BAUD parameter

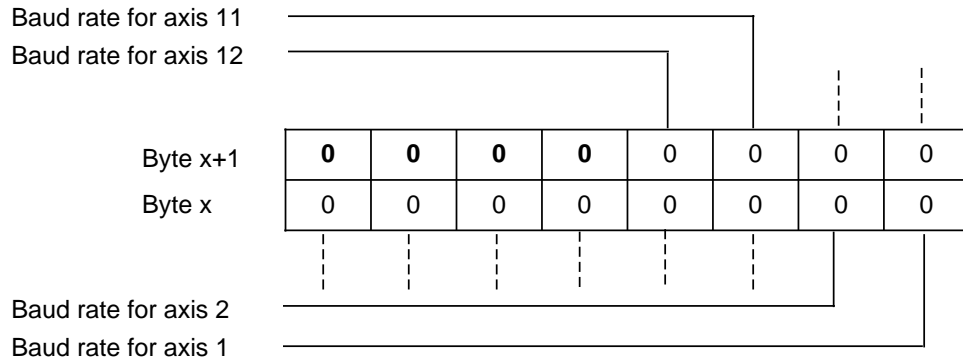

Example:

The following actual values are to be read out:

- Axes 1, 2, 4 with 125 Kbit/s (120 m cable)
- Axes 3, 12 with 1 Mbit/s (25 m cable)

0804_{Hex}

Byte x+1	0	0	0	0	1	0	0	0
Byte x	0	0	0	0	0	1	0	0



Only those bits of the BAUD parameter are evaluated which have been selected in the ACHS parameter.

4.2.6 Assignment of the DBBG Work Data Block

If the DBBG work data block does not exist yet, it will be generated by the function FC ANL_705 with a length of 100 bytes during an initial start or a restart. If the user generates the DBBG, the bytes from DBB 100 will be available to the user.

DBBG for one WF 705

Data block - data byte/doubleword	Comment	Format
DBB0 ...47	Used internally or reserved	D _{integer}
DBD48	Actual position value of axis 1	D _{integer}
DBD52	Actual position value of axis 2	D _{integer}
DBD56	Actual position value of axis 3	D _{integer}
DBD60	Actual position value of axis 4	D _{integer}
DBD64	Actual position value of axis 5	D _{integer}
DBD68	Actual position value of axis 6	D _{integer}
DBD72	Actual position value of axis 7	D _{integer}
DBD76	Actual position value of axis 8	D _{integer}
DBD80	Actual position value of axis 9	D _{integer}
DBD84	Actual position value of axis 10	D _{integer}
DBD88	Actual position value of axis 11	D _{integer}
DBD92	Actual position value of axis 12	D _{integer}
DBD96	Reserved	

Data format of the actual value, e.g. for axis 1

DBB48	0	0	0	0	0	0	0	2 ²⁴
DBB49	2 ²³							2 ¹⁶
DBB50	2 ¹⁵							2 ⁸
DBB51	2 ⁷							2 ⁰

4.3 Example of Position Measuring

The standard diskette of the function blocks (FC's) contains an example of position measuring for the use of the WF 705 in the SIMATIC S7-400.

4.4 Addressing the WF 705 as SIMATIC S7-400 Periphery

The WF 705 module can be used in the SIMATIC S7-400 in different ways:

- In a SIMATIC S7-400 central unit by means of SIMATIC S5 adapter casing
- In a SIMATIC S5 extension unit linked with the central unit of the SIMATIC S7-400 via interfaces IM463-2 (S7) and IM314 (S5).

In the SIMATIC S7-400 central unit, you can plug:

- Up to 8 adapter casings, i.e. up to 8 WF modules
- Up to 4 IM463-2; each IM463-2 can be linked with up to 8 SIMATIC S5 extension units.

In a SIMATIC S7-400 system, you can address:

- Up to 64 WF 705 modules

STEP7-Tool HWKonfig (hardware configuration) is needed for:

- Configuration of the adapter casing
- Configuration of the IM463-2 interface

4.4.1 Settings

The following settings have to be made in HWKonfig:

- Entry:
 - Only one WF module can be operated in one adapter casing. Therefore, only one entry per casing is admissible..
 - For the IM463-2 interface, one entry must be generated for each WF module. As several S5 extension units can be linked via one IM463-2, the entries refer to the total number of modules.
- S7 address:
 - Address under which the WF 705 is to be addressed in the S7 program (starting address).
 - This address must be parameterized during start-up, when calling FC100, with parameter "ADR".
 - S7 addresses start at 512.
- S5 address:
 - Address which is set by the addressing switch S1 on the WF 705. The range is set separately.
- Length (dual-port RAM)
 - The WF 705 has a fixed length of 4 bytes.



If the WF 705 has the address n, the next S7 address for the WF 705 must be n+4.

- Part PA:
 - For WF modules, 0 must be set.
- Range:
 - In the adapter casing, only range P is admissible.
Via the IM463-2 interface, ranges P and Q can be selected.



The corresponding ranges must also be set on the IM314.



Make sure that neither S7 addresses nor S5 addresses overlap.



Input and output address of the S5 adapter casing, parameterizable via HWKonfig, must be identical. This is an unconditioned prerequisite for the correct application of the Standard functions of FC100: ANL_705.

Addressing example

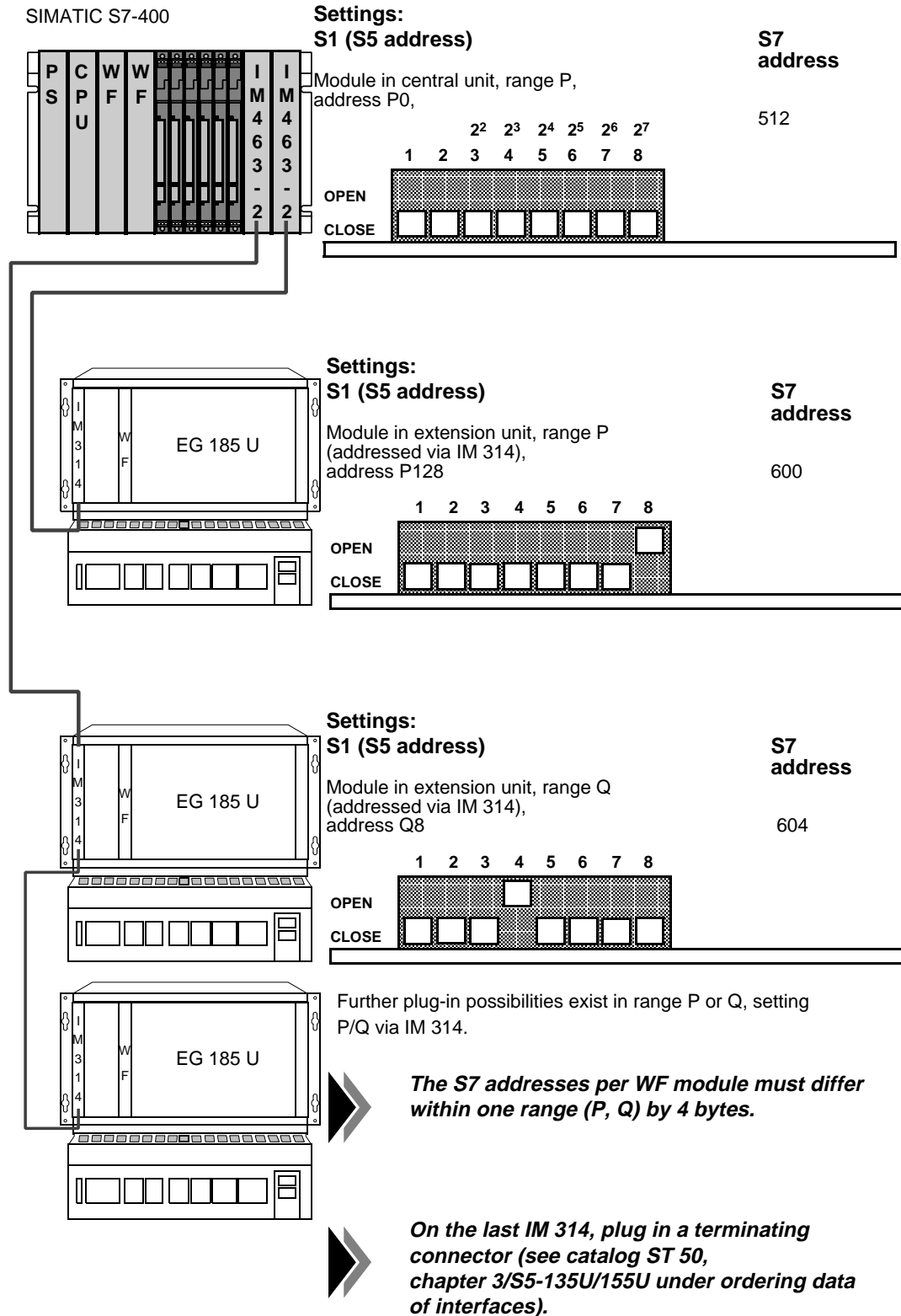

4.4.2 Commissioning/Trouble-Shooting



4.4.2.1 WF 705 Jumper and Switch Settings

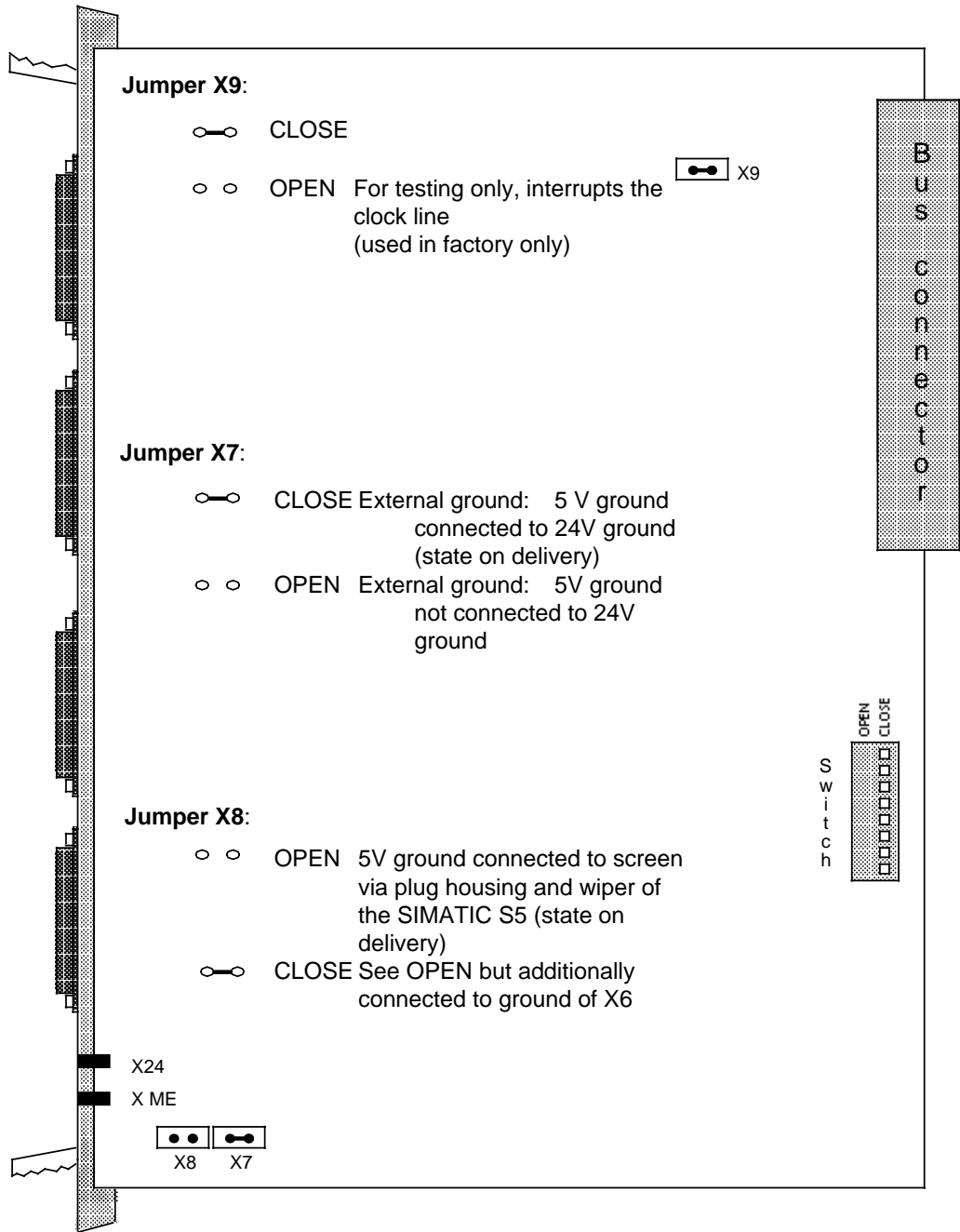

WF 705

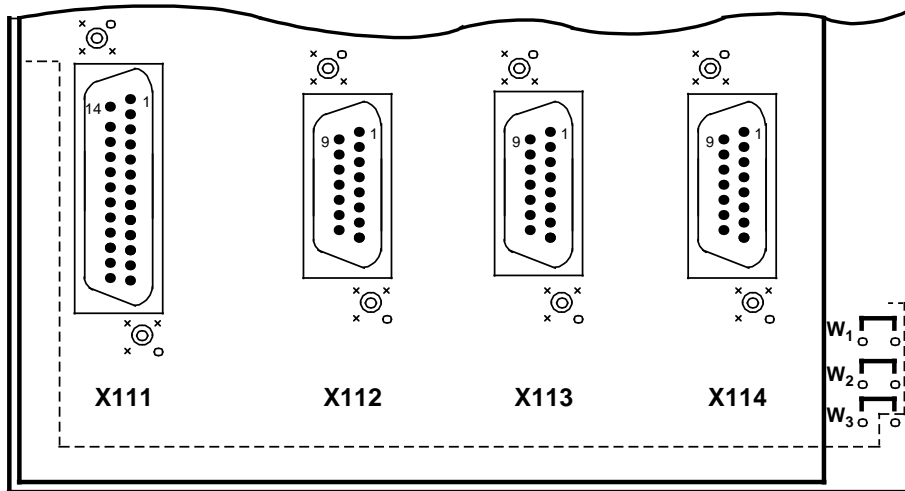



4.4.2.2 Jumper Settings on the Actual Value Distributor:



Jumper W1:  CLOSE Screen with external ground
  OPEN (No function in WF 705)

Jumper W2:  CLOSE Connection of external 24V ground to WF 705 module
  OPEN

Jumper W3:  CLOSE (No function in WF 705)
  OPEN

4.4.2.3 Information about Trouble-Shooting

Please check the following items:

- Is the address set on the module the same as the one parameterized in FC100?
- Is the 24V DC power supply for the encoders connected to the actual value distributor and/or connected directly to the WF 705 module?
- If no position values are read-out for certain axes or if the values do not change when the encoder is turned by hand, e.g. 1AAA AAAA or 003A AAA5, check the following:
 - whether a read-out has been requested for the axes in question;
 - whether the cable break monitor has been triggered;
 - whether an encoder has been connected for that axis;
 - whether the cable has been connected correctly. If necessary, change the connector.
- whether Jumpers X7 are open except for one module
- whether jumpers X8 are open and the encoder cables's screens are generously grounded (see chapter 4.3)

4.5 Multiprocessing

In multiprocessing, one WF module each has to be assigned to a certain central processor. It is not possible to address a WF module from different central processors.

No standard block is provided with an interlocking for multiprocessing. Access is possible from any processor (user's responsibility).

5 Technical Data

5.1 Characteristics of the Module

Electrical and mechanical characteristics	WF 705
Voltage level DC 5 V	is supplied by SIMATIC
Internal current consumption at DC 5 V (without encoders)	500 mA
Voltage level DC 24 V for encoders	has to be externally provided via connector X6
Inputs 24 V	–
Outputs 24 V	–
Max. admissible current consumption per encoder in case of direct connection	300 mA
Necessary input current of encoder signals	10 mA
SSI absolute encoder: Transfer rate up to a distance of 25 m up to a distance of 120 m Data length Code	1 MBit/s 125 Kbit/s 25 bit Gray
Space required in SIMATIC S5 rack	1 ¹ / ₃ SEP
Space required in SIMATIC S7 rack	2 ² / ₃ SEP

The WF 705 module does not need a fan rack.

5.2 Connection of the Module

5.2.1 Overview of Cables and Devices

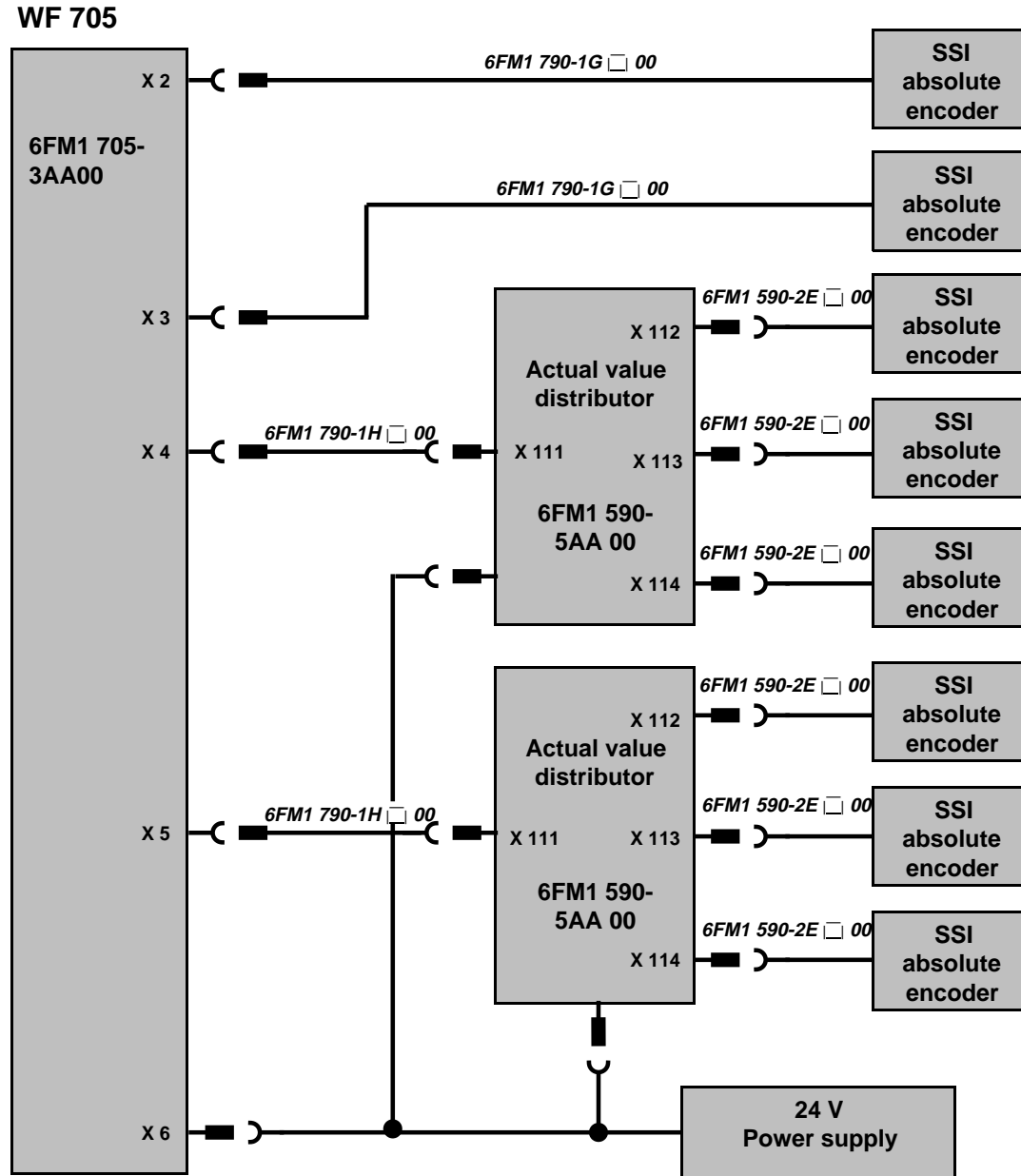

See chapter 5.2.2 for pin assignment of the front connectors.
Observe the screening instructions in chapter 6!

6FM1 790-1G □ 00
↑
Space for
the length code

For details, see chapt. 7

5.2.2 Pin Assignment of Front Connectors

The following table shows the pin assignment for SSI absolute encoders (synchronous serial interface for absolute angular encoders).

If up to 4 encoders are connected, only one encoder will be connected per connector (for the corresponding graphics, refer to chapter 2; for cable, refer to chapter 5.2.3).

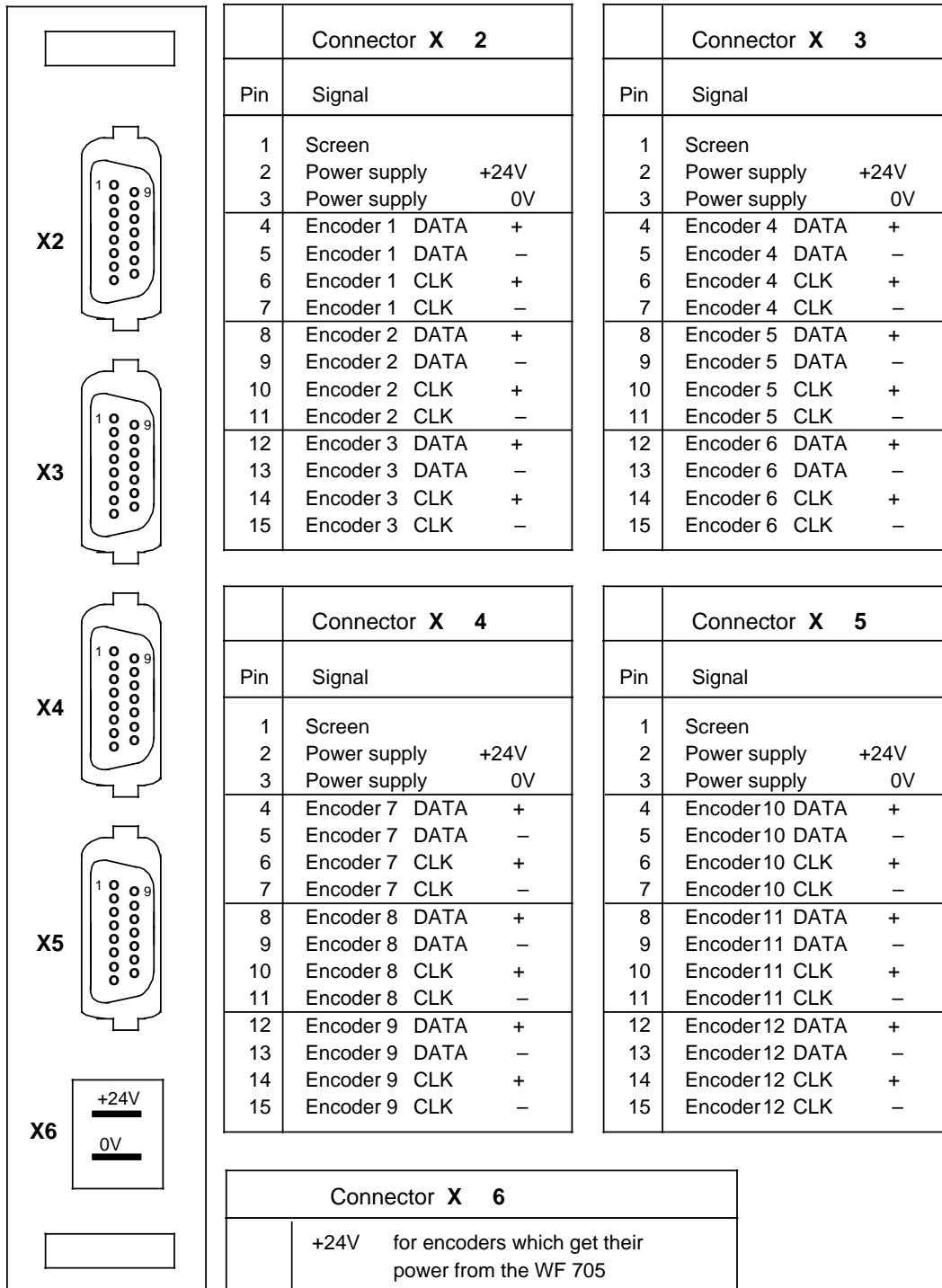

5.2.3 Cable from WF 705 Module to SSI Absolute Encoder

Cable from WF 705 module directly to encoder, no connector on cable.
 This cable is always connected to the first axis in the front connector.

Order No.: **MLFB 6FM1 790-1G □00**

WF 705	Encoder side
Front connector X2, X3, X4, X5	No connector on cable
15-pin with screw attachment	Connection as specified by encoder manufacturer

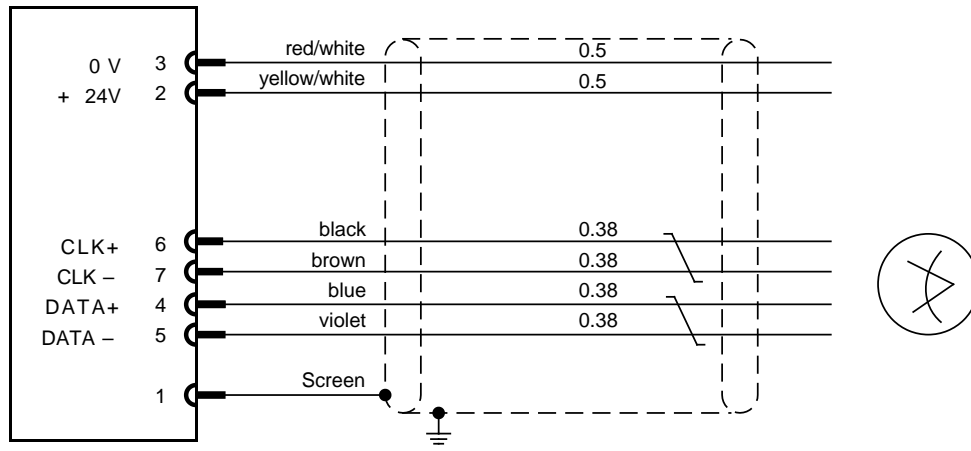

Cable 4 x 2 x 0.38 twisted in pairs
 4 x 0,5

ID. No.: 649 70967

Connector

D-Sub, Cannon
 15-pin, male
 6FM1 790-8DA00

Connection side

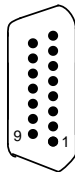

The screen of the actual value cable must be generously grounded on the component side (refer to chapter 6).

5.2.4 Cable from Actual Value Distributor to SSI Absolute Encoder

Order No.: **MLFB 6FM1 590-2E □00**

Actual value distributor Front connector X112/113/114	Encoder side No connector on cable Connection as specified by encoder manufacturer
---	--

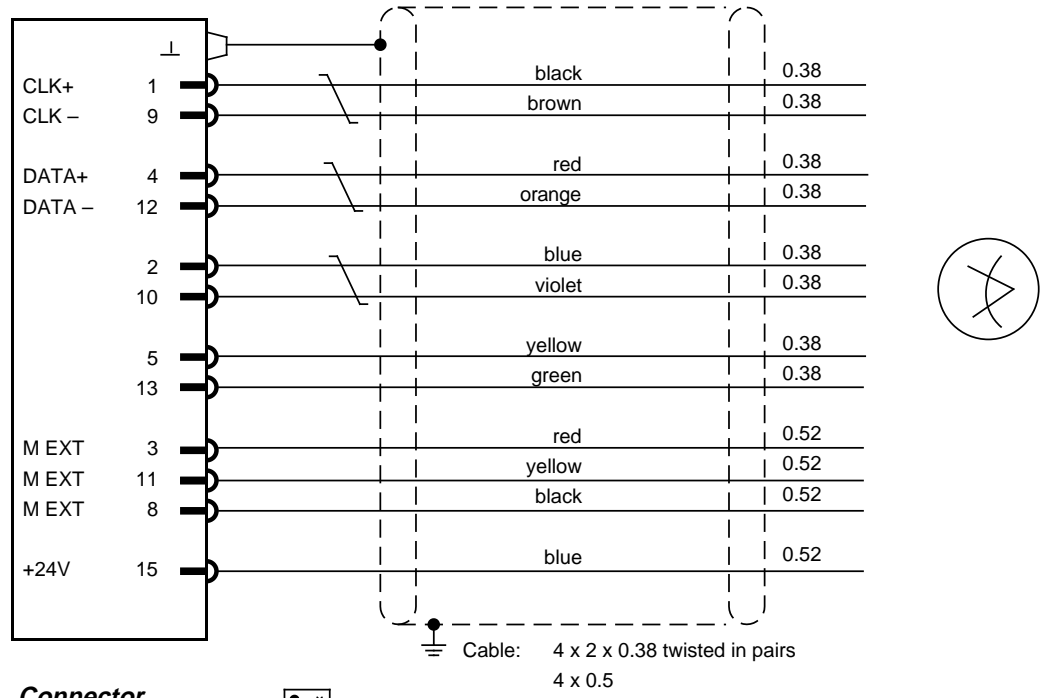

Connector
D-Sub
15-pin, female
SINUMERIK casing
6FC9 341-1EC
Front view

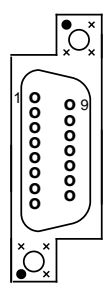

Connector code

- pin/socket
- × no pin/no socket

The screen of the actual value cable must be generously grounded on the actual value distributor side (refer to chapter 6).

6 EMV-Hinweise

The ensure faultless control operation the complete installation must be grounded.

The information about electromagnetic fields offers some suggestions for increasing noise immunity against different earth potentials and electromagnetic fields.



The following subjects will be dealt with:

- The connection principle of equipotential bonding
- Simplification of the connection principle for saving equipotential bonding
- Potential connection of power and non-power components
- Grouping of equipotential bondings on the bonding strip
- Connection of screening circuits.

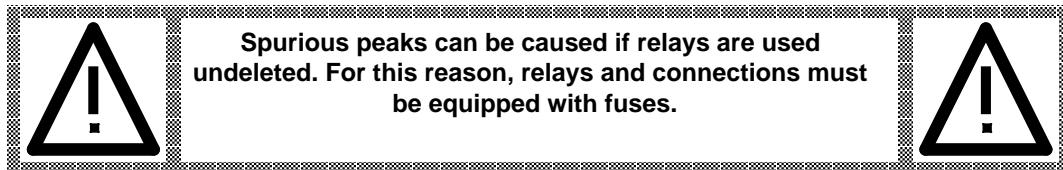
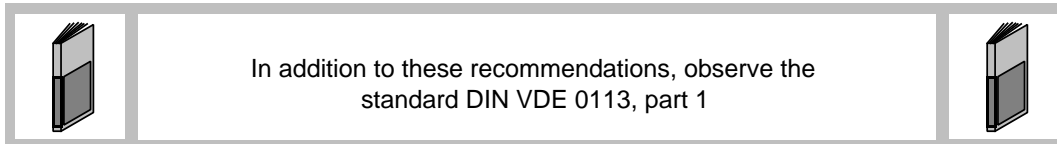

7 Ordering Data/Documentation

Devices and Modules	Order Number	Max. Length
WF 705		
• Use in the SIMATIC S5 and its extension units	6FM1 705-3AA00	–
• Use in the SIMATIC S7-400 incl. adapter casing	6FM1 705-3AA70	–
Actual value distributor	6FM1 590-5AA00	–
Software Package on 3.5" diskettes	Order Number	
Standard software package for WF 705 (actual value measuring) for use in the SIMATIC S5/S7-400	6FM1 705-7UA30-1AA0	– – –
Connecting Cables	Order Number	
WF 705 – SSI absolute encoder (no connector on cable)		
2 m	6FM1 790-1GA00	Depending on the baud rate: 120 m at 125 Kbit/s 25 m at 1 Mbits/s
5 m	6FM1 790-1GB00	
10 m	6FM1 790-1GC00	
18 m	6FM1 790-1GD00	
WF 705 – to actual value distributor		
2 m	6FM1 790-1HA00	10 m
5 m	6FM1 790-1HB00	
Actual value distributor to SSI absolute encoder (no connector on cable)		
5 m	6FM1 590-2EB00	Depending on the baud rate: 120 m at 125 Kbit/s 25 m at 1 Mbits/s
10 m	6FM1 590-2EC00	
18 m	6FM1 590-2ED00	
Documentation		
WF 705 Product Brief	6ZB5 400-0AD02-0BA1	–
WF 705 Description	6ZB5 400-0AA02-0BA5	–

Siemens AG

AUT 22

Postfach 3180

D-91050 Erlangen

Fed. Rep. of Germany

Suggestions

Corrections

For Publication/Manual:

WF 705
Position Measuring Module

Description

Order No.: 6ZB5 440-0AA02-0BA5
Edition: November 1996

From:

Name _____

Company/Dept. _____

Address _____

Telephone _____ /

Should you come across any printing errors when reading this publication, please notify us on this sheet. Suggestions for improvement are also welcome.

Suggestions and/or corrections:

Siemens AG
Bereich Automatisierungstechnik
Geschäftsgebiet Automatisierungssysteme für Werkzeugmaschinen,
Roboter und Sondermaschinen
Postfach 3180, D-91050 Erlangen
Federal Republic of Germany

© Siemens AG 1996
Subject to change without prior notice

Siemens Aktiengesellschaft

Order No.: 6ZB5 440-0AA02-0BA5
Printed in the Fed. Rep. of Germany
232/720055 BS 03970.1