

SIEMENS

SIMOREG K
6RA22 converter with microprocessor
in circulating-current-free
inverse-parallel connection (B6)A(B6)C

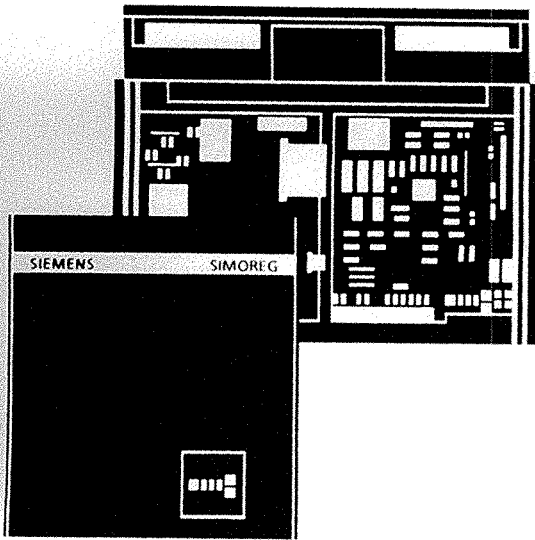

Operating instructions • 09.1991

Handwritten text at the top of the page, possibly a title or header, which is extremely faint and illegible.

Main body of handwritten text, consisting of several lines of cursive script. The text is very faint and difficult to decipher, but appears to be a continuous paragraph or list of entries.

SIEMENS

SIMOREG K

**6RA22 converter with microprocessor
from 12kW to 679kW in circulating-
current-free inverse-parallel
(B6)A(B6)C connection for
variable-speed DC drives**

Operating instructions

Equipment software release 3.2 and 3.3

Edition September 1991

IMPORTANT INFORMATION

These operating instructions include information regarding the functioning of the converter using software release 3.2 and 3.3. Although the operating instructions can be generally used on all previous software releases, specific parameter code and fault code definitions in these instructions under certain circumstances however exceed the specifications in previous software releases, or are contrary to these.

These operating instructions do not claim to include all equipment details or versions, or every conceivable situation regarding installation, operation or maintenance. Your local Siemens representative should be contacted if you require further information, or if special problems occur which have not been handled in sufficient depth for the purchaser's requirements.

Your local Siemens representative will provide detailed information regarding software releases.

NOTE

The contents of these operating instructions are not part of the scope of a previous or existing agreement, commitment or legal relationship, and as such does not change or modify these. The purchasing contract represents the complete liability of the ASI 1 Drive Technology Group of Siemens AG. The guarantee specified by the parties in the contract is the one and only guarantee accepted by the ASI Drive Technology Group. The contractual guarantee conditions are neither extended nor modified by this document.

This document was produced on the Siemens 5822 Office System

Subject to change without prior notice.

The reproduction, transmission or use of this document or its contents is not permitted without express written authority. Offenders will be liable for damages. All rights, including rights created by patent grant or registration of a utility model or design, are reserved.

© Siemens AG 1989

Unit Order No.	Type designation
6RA2218 - 6DV62 - 0	D400 / 30 Mreq - GdG6V62
6RA2225 - 6DV62 - 0	D400 / 60 Mreq - GdG6V62
6RA2228 - 6DV62 - 0	D400 / 90 Mreq - GdG6V62
6RA2232 - 6DV62 - 0	D400 / 130 Mreq - GdG6V62
6RA2218 - 6GV62 - 0	D520 / 30 Mreq - GdG6V62
6RA2225 - 6GV62 - 0	D520 / 60 Mreq - GdG6V62
6RA2228 - 6GV62 - 0	D520 / 90 Mreq - GdG6V62
6RA2232 - 6GV62 - 0	D520 / 130 Mreq - GdG6V62

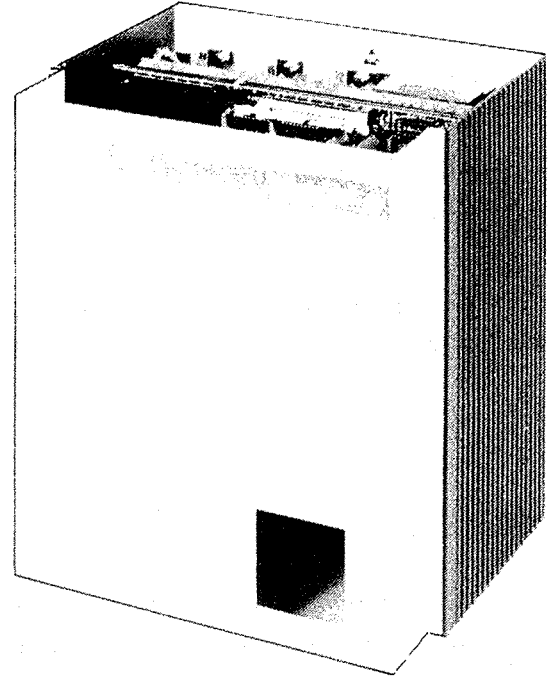

Units without separately driven fan

6RA2275 - 6DV62 - 0	D400 / 200 Mreq - GdGF6V62
6RA2277 - 6DV62 - 0	D400 / 250 Mreq - GdGF6V62
6RA2281 - 6DV62 - 0	D400 / 400 Mreq - GdGF6V62
6RA2285 - 6DV62 - 0	D400 / 600 Mreq - GdGF6V62
6RA2275 - 6GV62 - 0	D520 / 200 Mreq - GdGF6V62
6RA2277 - 6GV62 - 0	D520 / 250 Mreq - GdGF6V62
6RA2281 - 6GV62 - 0	D520 / 400 Mreq - GdGF6V62
6RA2285 - 6GV62 - 0	D520 / 600 Mreq - GdGF6V62

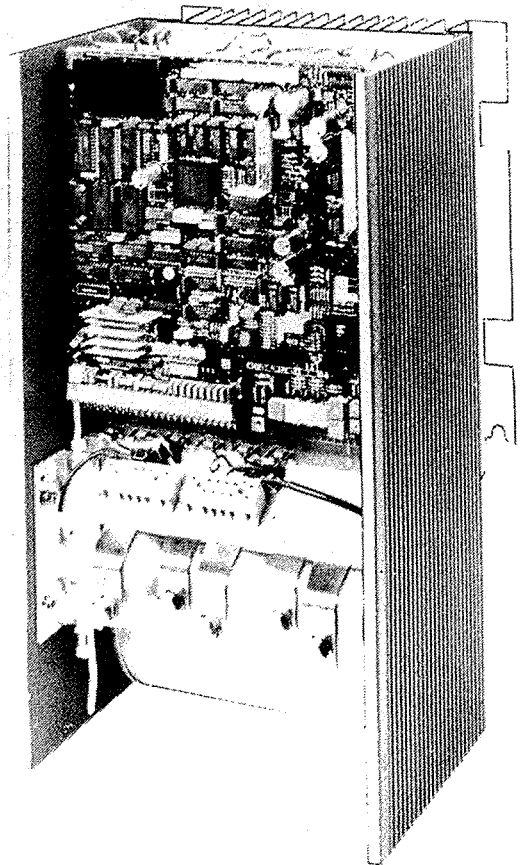
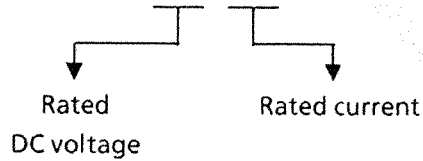

Units with separately driven fan

Contents

	Page
1. Introduction	9
1.1 General warning notes	9
1.2 Description	11
2. Technical data	13
3. Installation	17
3.1 Dimension drawings	20
3.2 Position of boards, ribbon cables, control leads and terminal strips	26
4. Connecting up	29
4.1 Block diagram with recommended connection	31
4.1.1 Connection schematic for a SIMOREG unit in parallel with a 6QG25 SITOR thyristor set	34
4.2 Power connections	35
4.3 Field supply	37
4.4 Load resistors	37
4.5 List of fuses and commutating reactors	41
4.6 Terminal assignment	44
5. Start-up	55
5.0 General warning notes regarding start-up	55
5.1 Parametrizing device	56
5.2 Parametrizing procedure	57
5.3 Potentiometers	58
5.4 Initial program loading	59
5.5 Start-up procedure	60
5.5.1 Current control optimization	66
5.5.2 Speed control optimization	67
5.5.3 Field characteristic test	69
5.5.4 EMF controller optimization	70
5.6 Manual optimization of the feed-forward current control	71
5.6.1 Setting the feed-forward control	71
5.6.2 Current controller setting	72
5.7 Manual speed control optimization	72
5.8 Field characteristic for field weakening operation	73
5.9 Storing the parameters in a non-volatile memory	76

	Page
6. Operating conditions	77
7. Fault messages	79
7.1 Fault message acknowledgement	79
7.2 Fault list	80
7.2.1 Supply faults	80
7.2.2 Motor-related faults	81
7.2.3 Open-loop fault	82
7.2.4 Internal fault messages	82
7.2.5 Start-up faults	83
7.2.6 Power section faults	84
8. Setting supplementary functions	89
8.1 Set current limits	89
8.2 Speed-dependent current limiting	89
8.3 Thermal overload protection of the DC motor (I^2t monitoring)	90
8.4 Standstill monitoring using relay K1	92
8.5 Reduced gearbox wear	92
8.6 Special "crawl" function	92
8.7 Stall protection	92
8.8 Ramp-function generator	93
8.9 Speed controller adaption	94
8.10 Operation without tachometer (EMF closed-loop control)	96
8.11 Torque control	97
8.12 Changeover from speed to current controlled operation	97
8.12.1 Changeover using parameter P89	97
8.12.2 Changeover from speed control/current control via selector terminal	98
8.12.3 Master-slave changeover	98
8.13 Operation on weak supply networks	98
8.14 Switching-out monitoring functions	99
8.15 Software replacement	102
9. Parameter list	105
10. Service instructions	129
11. Spare parts	129
12. Start-up log	131
13. Additional documentation	133

1 Introduction

1.1 General warning notes



WARNING

This equipment contains hazardous voltages and hazardous rotating mechanical components (fans).
Loss of life, severe personal injury or property damage can result if instructions contained in this manual are not followed.



Only qualified personnel should work on this equipment, and only after becoming familiar with all safety instructions regarding installation, operation and maintenance procedures contained in this manual. The successful and safe operation of this equipment is dependent on proper handling, installation, operation and maintenance of the equipment.

Definitions:

Qualified personnel

For the purpose of this manual and product labels, a qualified person is one who is familiar with the installation, construction, operation and maintenance of this equipment, and the hazards involved. Further, the person must have the following qualifications:

- a) Trained and authorized to energize, de-energize, ground and tag circuits and equipment in accordance with established safety procedures.
- b) Trained in the proper care and use of protective equipment, in accordance with established safety procedures.
- c) Trained in rendering first aid.

DANGER

For the purpose of this manual and product labels, danger indicates loss of life, severe personal injury or substantial property damage which will result if proper precautions are not taken.

WARNING

For the purpose of this manual and product labels, warning indicates loss of life, severe personal injury or substantial property damage which can result if proper precautions are not taken.

CAUTION

For the purpose of this manual and product labels, caution indicates minor personal injury or property damage which can result if proper precautions are not taken.

NOTE

For the purpose of this manual, notes merely call attention to information that is especially significant in understanding the product or the applicable section of the description.



DANGER

Hazardous voltages are used in the operation of this equipment, and will cause severe personal injury or loss of life. The following precautions should be followed to reduce risk of injury or death.

1. Only qualified personnel familiar with this equipment and the information supplied with it should be permitted to install, operate, troubleshoot or repair the equipment.
2. Installation of the equipment must be done in accordance with the relevant safety regulations (e.g. DIN, VDE) as well as all other national or local regulations. Proper grounding, conductor sizing and short-circuit protection must be installed to ensure safe operation.
3. During normal operation, keep all covers in place and cabinet doors shut.
4. When performing visual inspections and maintenance, be sure the incoming AC feed is turned off and locked out, and there is no dangerous voltage available at the signaling relays K1, K2 and K4 . . . K7 (on the Z1210 supplementary board, if available). The converter and motor will have hazardous voltages present until the AC feed is turned off. Even when opened, the drive contactor does not remove hazardous voltages.
5. When it is necessary to make measurements with the power turned on, do not touch any electrical connection points. Remove all jewelry from wrists and fingers. Make sure test equipment is in a good safe operating condition.
6. While servicing with the power on, stand on some type of insulation, to ensure not to be grounded.
7. Follow the instructions given in this manual carefully and observe all danger, warning, and caution notices.
8. This list does not represent an exhaustive survey of the steps necessary to ensure safe operation of the equipment. Should further information be desired, or should particular problems arise which are not covered sufficiently for the purchaser's purposes, the matter should be referred to the local Siemens sales offices.



1.2 Description

6RA22 SIMOREC K converters for three-phase connection are fully-digital compact units for DC drives.

All open-loop and closed-loop control functions are realized with a 16-bit microprocessor, from the ramp-function generator to the gating unit, as well as almost all auxiliary functions. An integrated keyboard with digital display makes the unit autonomous. Additional equipment for parametrization and start-up are thus not required.

Firing angle precontrol which operates in parallel to the secondary current control circuit provides a high level of dynamic performance.

Adaption to the supply frequency of 45 to 65 Hz is automatic.

After power-up, the units indicate the operating status and check the tachometer polarity.

The armature supply is realized using two fully-controlled three-phase bridges in a circulating-current-free inverse-parallel connection.

Units for rated currents 30A to 600A, the power section for the armature and field is realized using electrically isolated thyristor modules, and thus the heatsink is floating. Side panels, front panel and panels covering the power connections provide protection against accidental contact when working in the vicinity of the units (protection against electric shock VDE 0106b / Part 100). All connecting terminals are dimensioned according to VDE 0113 A2, and are accessible from the front.

Units for rated currents 640 to 1200A, the power section consists of 6 plug-in SITOR blocks. The mechanical construction consists of a frame with insulating components and buses for accepting the 6 SITOR blocks. The power connections of the SITOR set are at the rear. The electronics is located at front of the unit so that it can be swung out.

An automatic controller optimization run can be started using a call parameter with which the control parameters of the speed controller, current controller and gating unit precontrol can be set.

SIMOREG K converters are characterized by a compact, space-saving design.

The special heatsink design for units with 30 to 600 A rated current permits a configuration where the heatsink or heatsink and fan are located outside the cubicle. This permits a favorable dissipation of the power loss from the cubicle.

Speed setpoint and actual values are input as analog values in the basic unit.

Supplementary boards permit setpoints and actual values to be digitally input (pulse tachometers) as well as technological expansions and coupling to higher-level automation systems.

Unit software release 3.2 and 3.3

The unit software release is visible:

at the last two locations of the EPROM labeling

in the parameter contents of P99 at the ten's and one's digits

The expanded functions of unit software 3.3 are designated in the operating instructions with SW 3.3.

2. Technical data

Order No.	6RA22...-6DV62								6RA22...-6GV62							
	18	25	28	32	75	77	81	85	18	25	28	32	75	77	81	85
Rated supply voltage/power V	3-ph. 380 V AC (+20% / -15%) ¹⁾ or 3-ph. 415 V AC (+10% / -22%)								3-ph. 500 AC (+10% / -15%) ¹⁾							
Rated supply voltage, electronics power supply V	2-ph. 380 V AC (+20% / -15%); I _n = 110mA or 2-ph. 415 V AC (+10% / -22%); I _n = 110mA															
Rated supply voltage, fan V	45 - 50 Hz: 2-ph. 380 V AC (+20% / -15%); 0.45A ^{3)a)} airflow: >50Hz: 2-ph. 380 V AC (+10% / -15%); 0.45A 550m ³ /h															
Rated supply voltage, field V	2-ph. 380 V AC (+20% / -15%) or 2-ph. 415 V AC (+10% / -22%)															
Rated supply frequency Hz	Units adjust automatically to the supply voltage frequency over a range from 45 to 65 Hz															
Rated DC voltage V	400								520							
Rated DC current A	30	60	90	130	200	250	400	600	30	60	90	130	200	250	400	600
Rated output kW	12	24	36	52	80	100	160	240	16	31	47	68	104	130	208	312
Power loss at rated current (approx.) W	90	180	270	390	600	750	1200	1800	90	180	270	390	600	750	1200	1800
Rated DC field voltage V	310															
Rated DC field current A	5	10			15	25	5	10			15	25				
Operational ambient temperature °C	0 to 45 at I _{rated} self-ventilated ³⁾				0 to 35 at I _{rated} sep. ventilated ³⁾				0 to 45 at I _{rated} self-ventilated ³⁾				0 to 35 at I _{rated} sep. ventilated ³⁾			
Storage and shipping temperature °C	-30 to +85															
Site altitude above sea level	≤ 1000 m at rated DC current ⁴⁾															
Control accuracy	Δn = 0.1% of rated speed ²⁾															
Humidity rating DIN 40040 SN 26556	F															
Degree of protection DIN 40050 IEC 144	IP 00															
Dimensions	refer to dimension drawings															
Weight (approx.) kg	8	14	14	14	23	23	29	29	8	14	14	14	23	23	29	29

Footnotes on page 15

Order No.	6RA22...-4DV6.		6RA22...-4GV6.		6RA22...-4KV6.5)		6RA22...-4KV6.5)	
	87	91	87	91	85	87	85	87
Rated supply voltage/power V	3-ph. 380 V AC (+20%/-15%) ¹⁾ 3-ph. 415 V AC (+10%/-22%)		3-ph. 500 V AC ¹⁾ (+10%/-15%)		3-ph. 660 V AC ¹⁾ (+10%/-15%)		3-ph. 750 V AC ¹⁾ (+10%/-15%)	
Rated supply voltage, electronics power supply V	2-ph. 380 V AC (+20%/-15%); I _n = 110mA							
Rated supply voltage, fan V	3-ph. 380 V AC (+20%/-15%); 0.68A ^{3)a)} airflow: 1260m ³ /h							
Rated supply voltage field ⁶⁾ V	2-ph. 380 V AC (+20%/-15%) or 2-ph. 415 V AC (+10%/-22%)							
Rated supply frequency Hz	Units adjust automatically to the supply voltage frequency over a range from 45 to 65 Hz.							
Rated DC voltage V	400		520		700		790	
Rated DC current A	850	1200	850	1200	640	860	640	860
Rated output kW	340	480	442	624	448	602	505	679
Power loss at rated current (approx.) W	3300	4900	3400	5000	4000	4800	4000	4800
Rated DC field voltage V	310 ⁶⁾							
Rated DC field current A	25 ⁶⁾							
Operational ambient temperature °C	0 to 35 Separately ventilated at rated current ³⁾							
Storage and shipping temperature °C	-30 to +85							
Site altitude above sea level	≤ 1000 m at rated DC current ⁴⁾							
Control accuracy	Δn = 0.1% of rated speed ²⁾							
Humidity rating DIN 40040 SN 26556	F							
Degree of protection DIN 40050 IEC 144	IP 00							
Dimensions	refer to dimension drawings							
Weight (approx.) kg	77							

Footnotes on page 15

- 1) The rated DC voltage of 400 V (520 V) can no longer be reached when the supply voltage is below 360 V (475V for 500V units).
- 2) Conditions:
The control accuracy is referred to the drive rated speed and is valid when the SIMOREG K unit is at operational temperature. This is based on the following conditions:
 - Temperature changes of $\pm 10\text{ }^{\circ}\text{K}$
 - Supply voltage changes of + 10% / - 5% of rated voltage
 - Load changes up to 100% of the maximum torque
 - Temperature coefficient of the temperature-compensated tachometer 0.15‰ per $10\text{ }^{\circ}\text{K}$

3) Loading as a function of the coolant temperature

Ambient/ coolant temperature	Change in the loading values		
	For units with natural air cooling	for units $\leq 600\text{A}$ with forced-air cooling	For units $> 600\text{A}$ with forced-air cooling
+ 30 °C	+ 13 %	+ 4 %	+ 4 %
+ 35 °C	+ 8 %	0 %	0 %
+ 40 °C	+ 4 %	- 6 %	- 5 %
+ 45 °C	0 %	- 12 %	- 10 %
+ 50 °C	- 6 %	- 17 %	- 15 %
+ 55 °C	- 11 %	(- 22 %) ^{a)}	
+ 60 °C	- 18 %		

a) only for 380V + 20% -15%, 50Hz fan supply

4) Loading as a function of the installation altitude

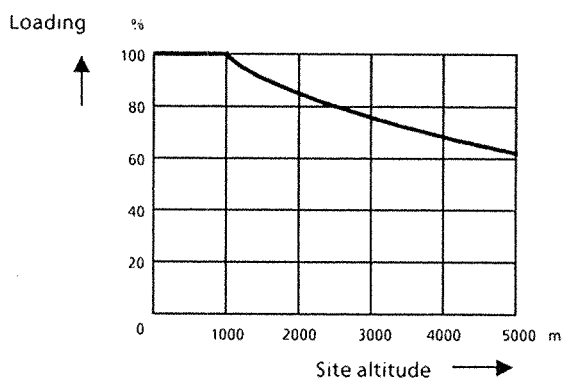

- 5) 6RA22...-4KV60 units, are suitable for 660 V and 750 V supply voltage of the power section
- 6) Only for 6RA22...-4.V62 units

NOTE

The units can also be directly connected to a 415V + 10% supply voltage (refer to Technical data).

3. Installation

 **Caution**

Incorrect lifting can lead to injury or material damage.

Only lift the unit using suitable equipment and with suitably qualified personnel.

 The user has the sole responsibility for installation of the converter, motor, transformer, as well as the other units in accordance with the relevant safety regulations (e.g. DIN, VDE) as well as all other applicable national or local regulations regarding cable dimensioning and protection, grounding, disconnect switch, overcurrent protection, etc.

The unit must be installed in accordance with all relevant safety regulations (e.g. DIN, VDE) as well as all other relevant national or local regulations. The operational safety of the unit should be ensured with correct grounding, cable dimensioning and appropriate short-circuit protection.

The converters are mounted vertically in cubicles or machine racks. They should be installed so that the terminal strips and connecting buses are below (refer to dimension drawings Section 3.1).

- **Units with 30A rated current**

These should be mounted with clearance to the mounting surface as otherwise the cooling panel could be distorted (this means lower current loading capability and danger that the thyristors are destroyed).

- **Units with 60A to 600A rated current**

These can be simply located on a removable mounting panel for installation. This mounting panel is part of the scope of supply of the unit, can be mounted in advance, and can be used as drilling template.

- Units with 640A to 1200A rated current

Cubicle installation

The cubicle mounting sets of the 6QG25 SITOR sets can be used for installing SIMOREG units in 8MF system cubicles. However, the side panels of the mounting unit must be removed on the SIMOREG unit. Both profile rails and panels are screwed at the required installation height to the perforated strips of the 600 mm wide system cubicle. The vertical position in the cubicle must be outside the area which must be kept free (door lock). Finally, the SIMOREG unit is positioned so that the angled flanges of the side components come in contact with the profile rails, and the SIMOREG unit can be inserted into the cubicle. The SIMOREG unit is then fixed using 4 M6 screws.

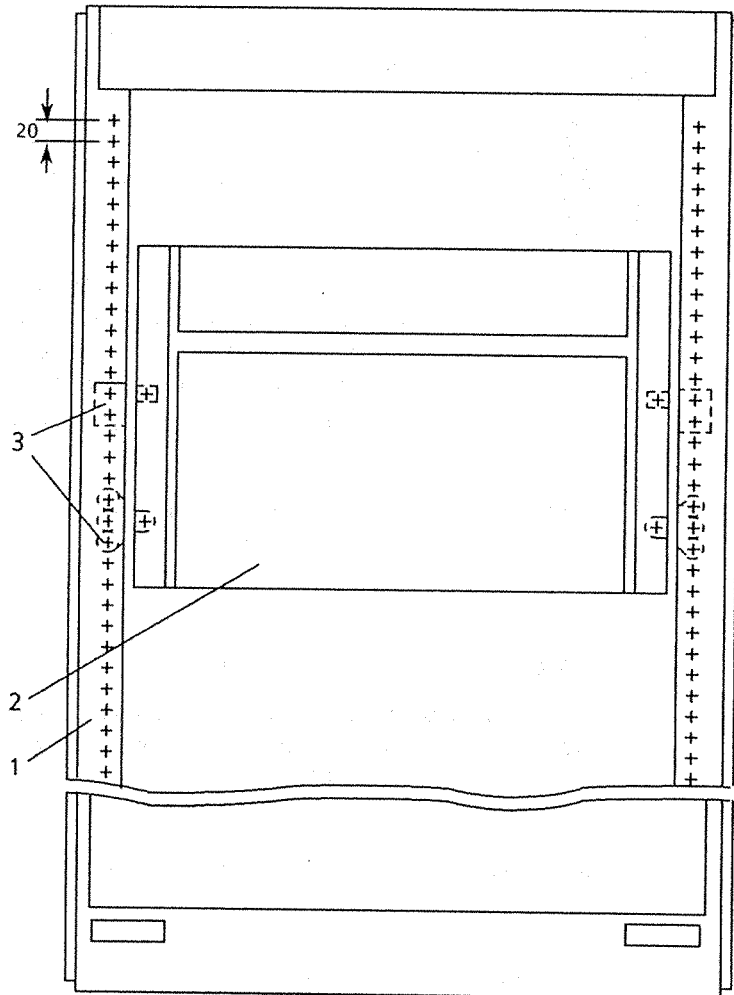

- 1 Cubicle frame (20mm hole spacing)
- 2 SIMOREG unit 6RA22
- 3 Cubicle mounting set (profile rail and panel)
 - for 600 mm deep cubicle 6QX5304
 - for 800 mm deep cubicle 6QX5305

Wall mounting

For wall mounting, the SIMOREG unit is located on the left and right on brackets, and is retained using 4 screws.

If a SIMOREG unit and a SITOR thyristor set are to be connected in parallel, and located one above the other (two-tier construction with common fan module on the upper SIMOREG unit), then the upper unit should be additionally retained to the wall with two angle brackets. For units located one above the other, power connection is only possible at the rear of the unit.

For parallel operation of SIMOREG unit and SITOR thyristor set, a ribbon cable, Order No. C98130-A1065-B403, is required.

Single-tier construction

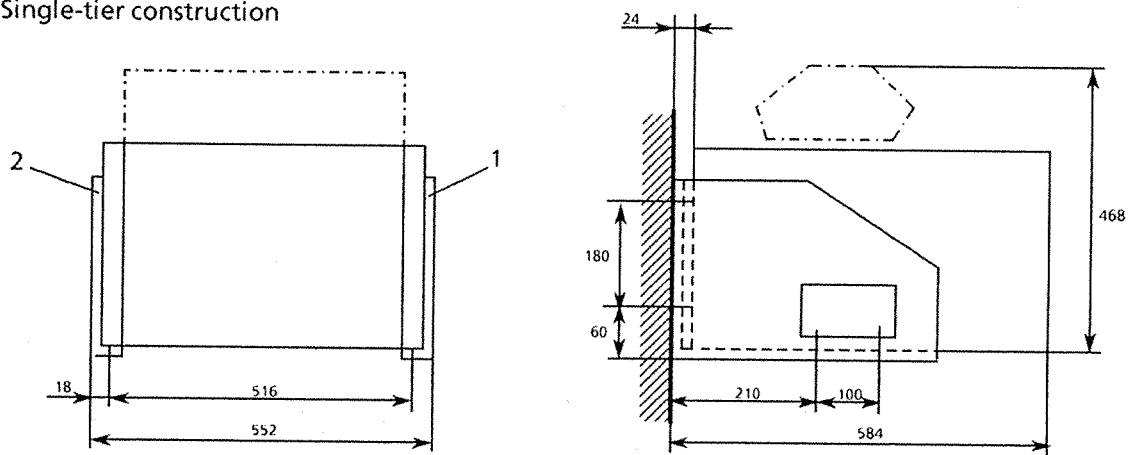

Two-tier construction

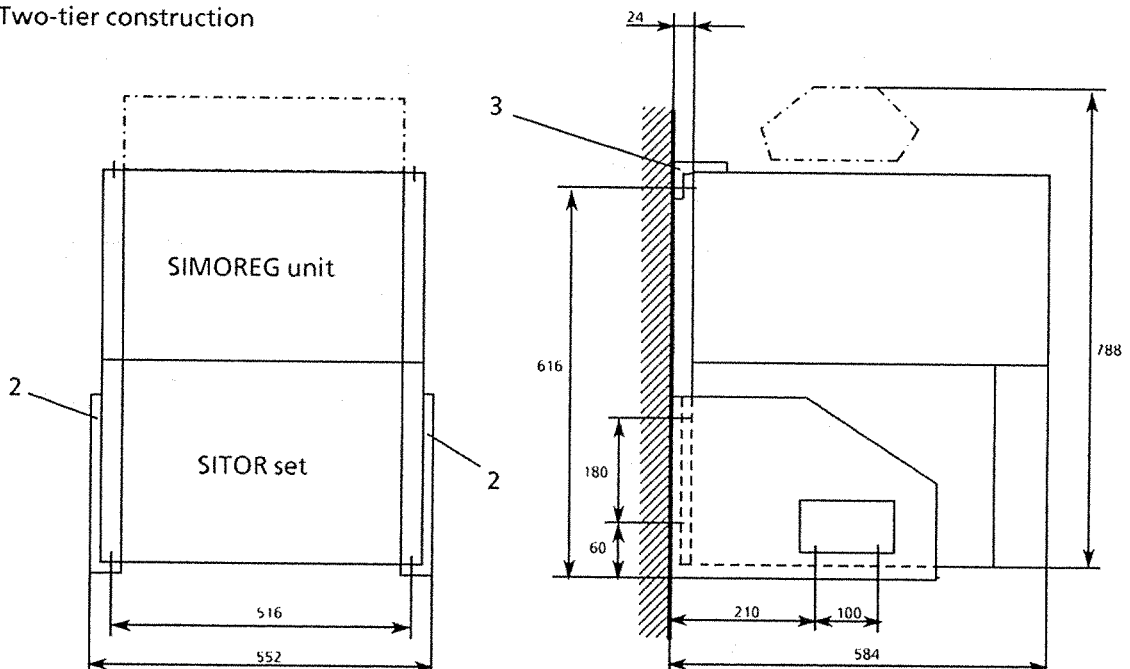

- | | | |
|---|---|---------|
| 1 | Bracket on the righthand side | 6QX5311 |
| 2 | Bracket on the lefthand side | 6QX5312 |
| 3 | Angle bracket (only for 2-tier configuration) | 6QX5061 |



WARNING

In order to ensure unrestricted cooling air inlet and outlet, a clearance of at least 100 mm must be retained at the top and bottom of the unit.

Danger of overheating exists if this is not observed!

3.1 Dimension drawings

Unit type D . / 30

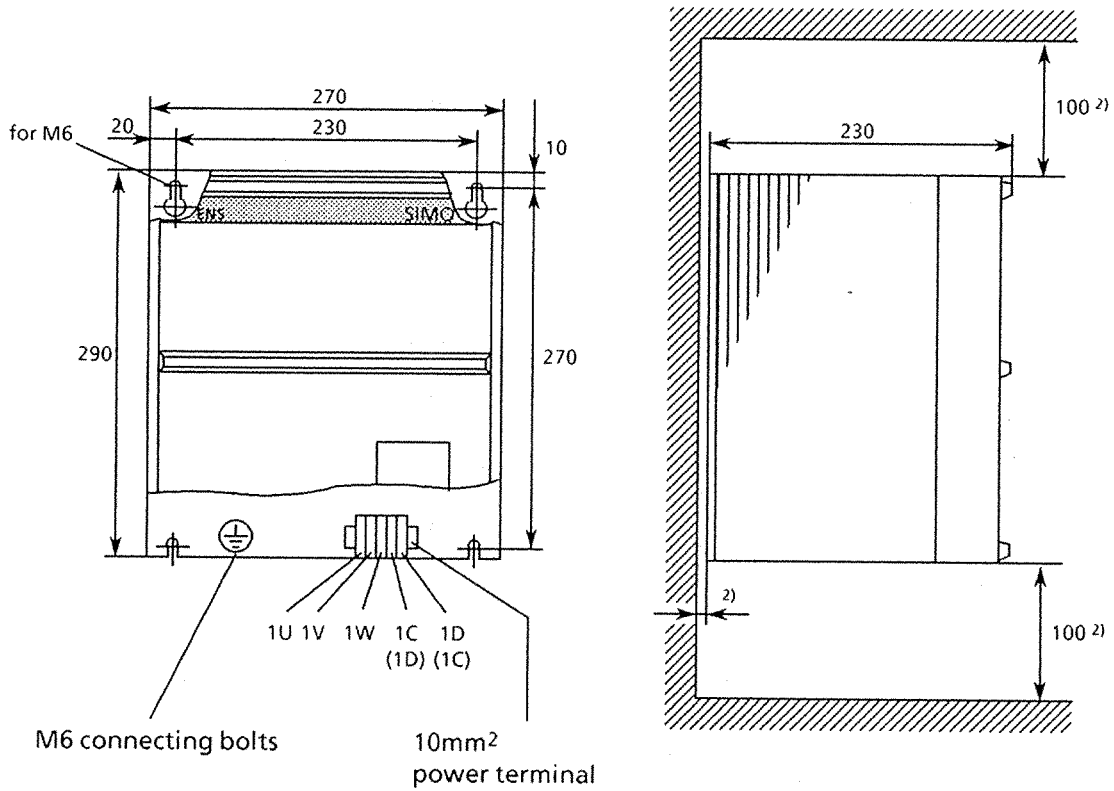

- 1) Mount with sufficient clearance.
- 2) Minimum space for air circulation.
Sufficient cooling air intake must be ensured!

Unit type D. / 60 - 130

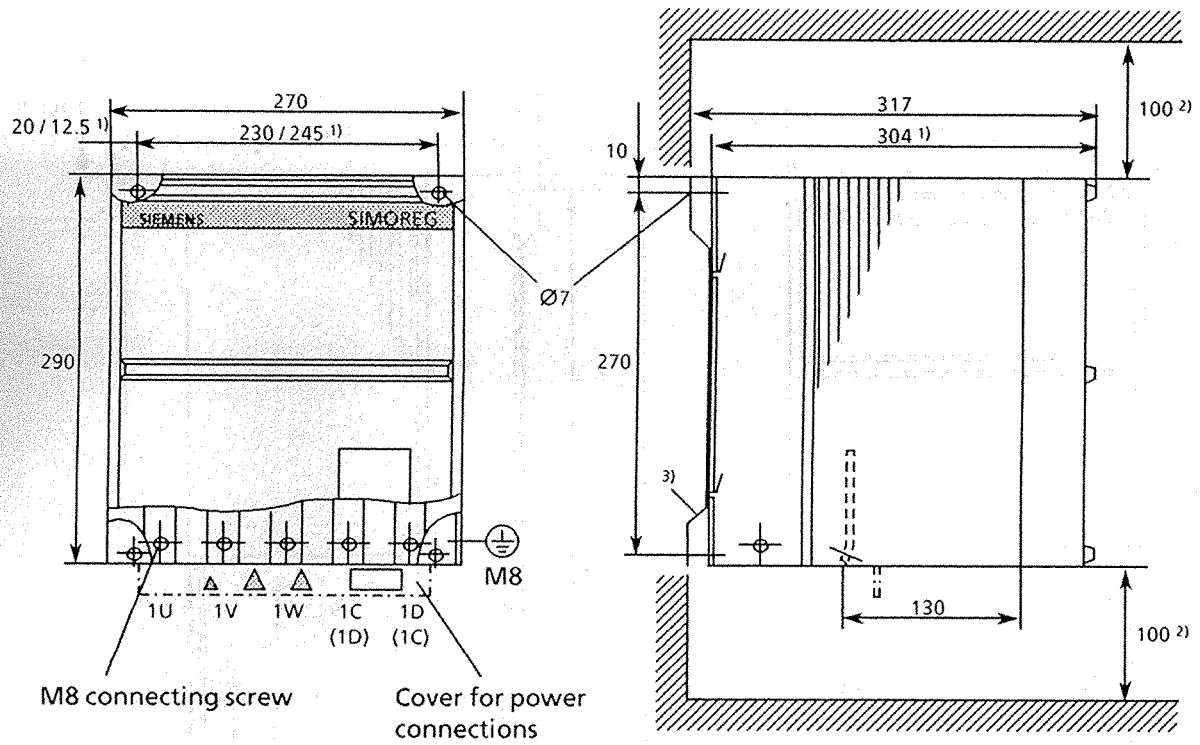

- 1) Valid for unit installation without mounting plate
- 2) Minimum space for air circulation.
Sufficient cooling air intake must be ensured!
- 3) Mounting plate

Unit type D. / 200 - 250

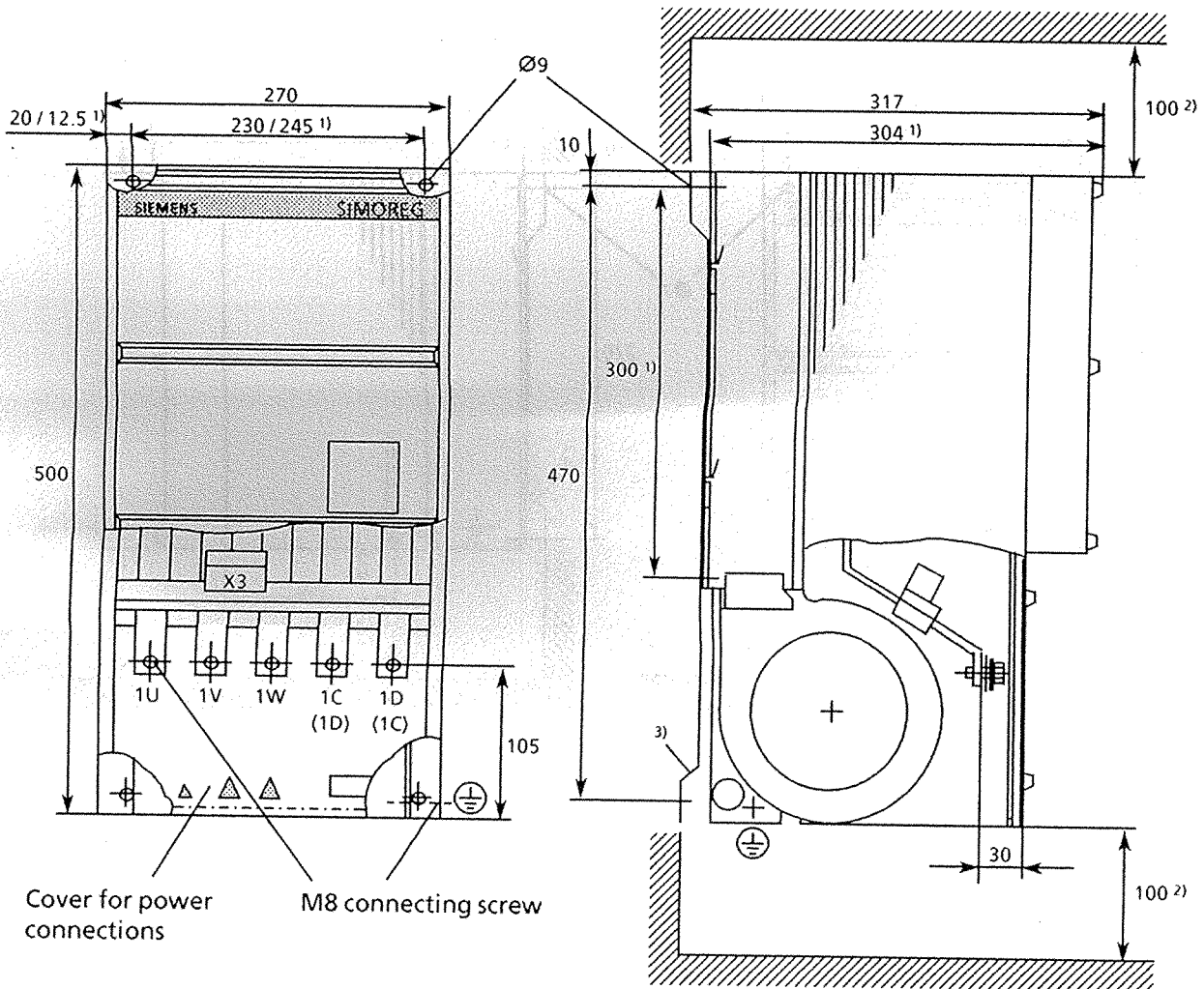

- 1) Valid for unit installation without mounting plate
- 2) Minimum space for air circulation. Sufficient cooling air intake must be ensured!
- 3) Mounting plate

Unit type D. / 400 - 600

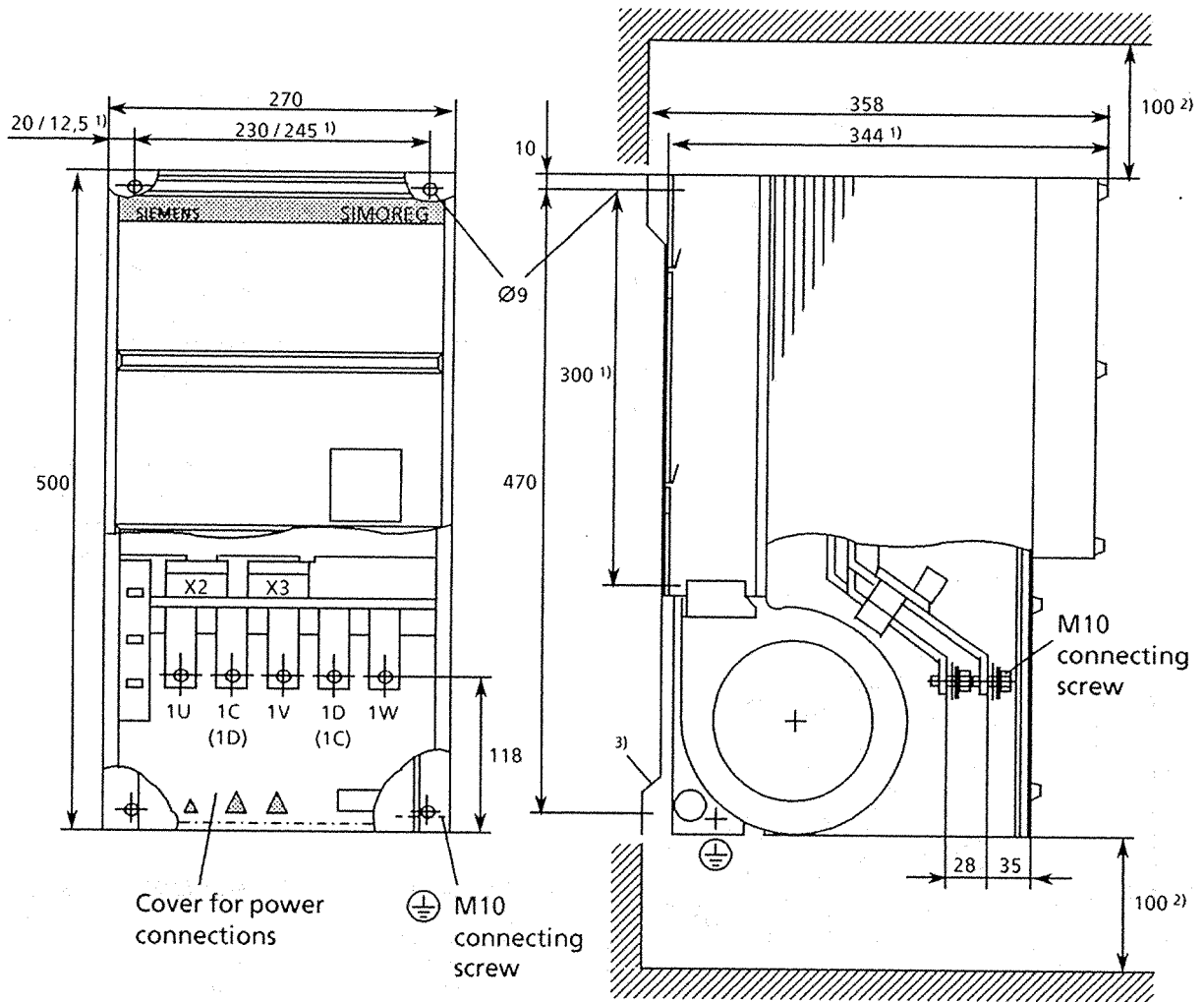

- 1) Valid for unit installation without mounting plate
- 2) Minimum space for air circulation.
Sufficient cooling air intake must be ensured!
- 3) Mounting plate

Unit type D. / 640 - 1200

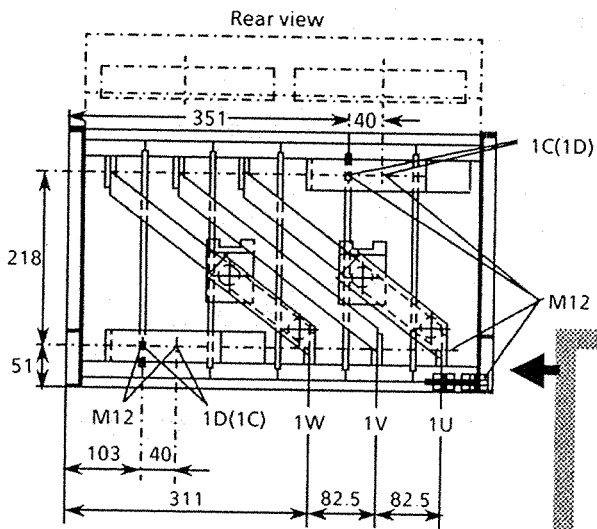
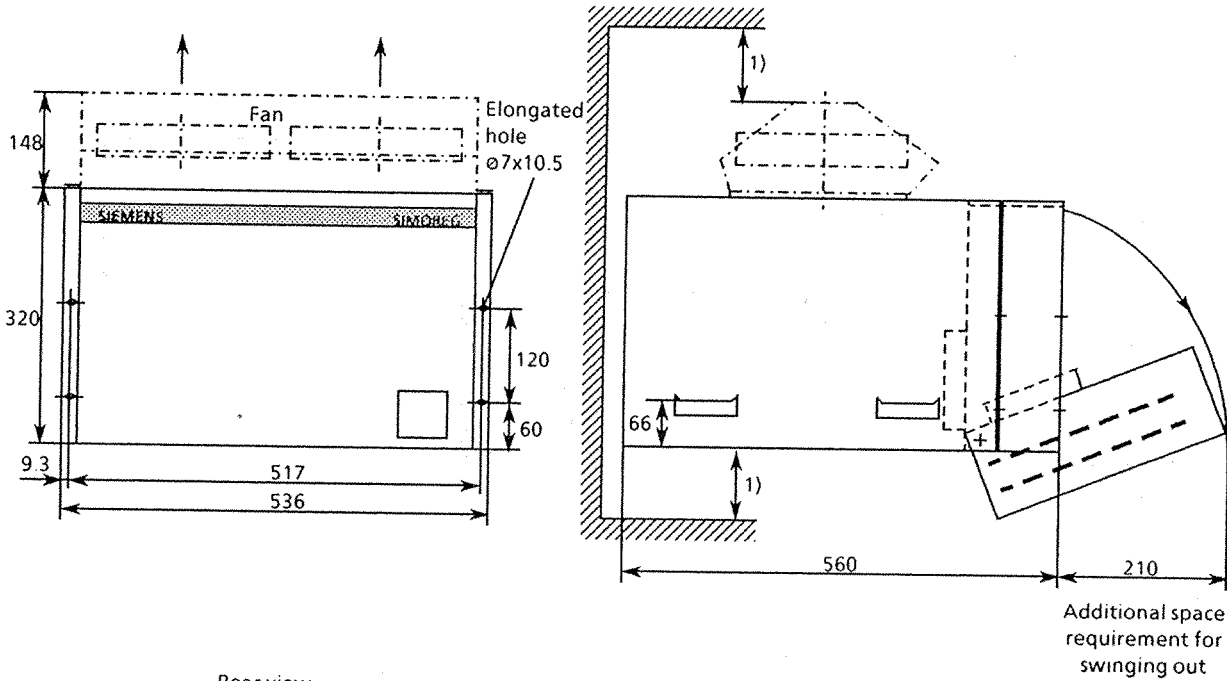

⚠ WARNING

Power connection for 1U, 1V, 1W must be made at the lower end of the busbars (i.e. at the lower right when viewing the rear of the unit).

⚡ The current actual value sensing cannot function when incorrectly connected (overcurrent - no current control - or current limiting).

1) Minimum space for air circulation.
Sufficient cooling air intake must be ensured!

Front connection (Order No.: 6RA8224-1AA0)

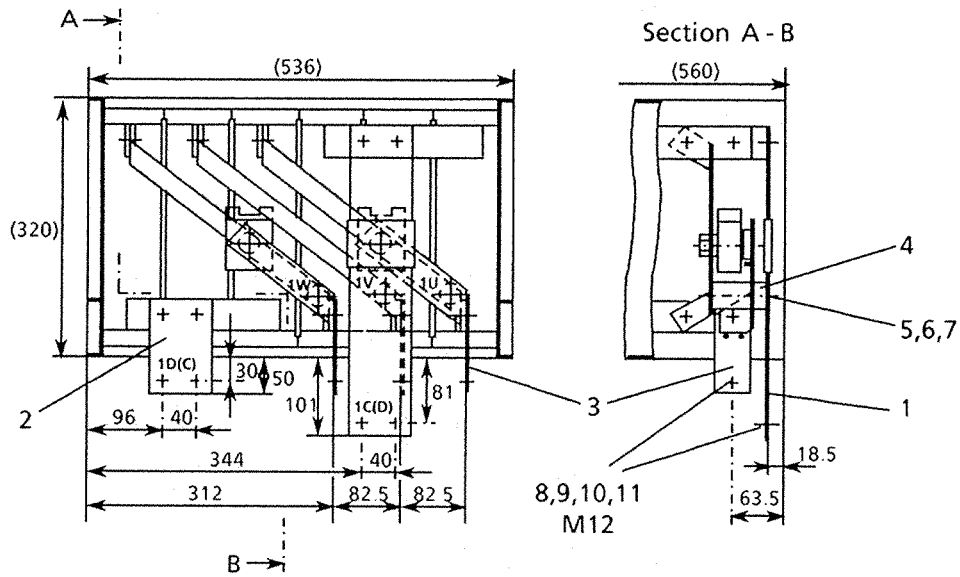

The 6RA8224-1AA0 parts set contains:

Item	Qty.	Designation	Part number
1	1	Busbar	C98130-A1075-B309
2	1	Busbar	C98130-A1075-C20
3	3	Connecting piece, compl.	4GE.464 065.7003.00
4	1	Insulator H = 60, D = 40, M8	Type: J3023 Fa. SIW
5	2	Hexagonal screw M8x20	D933-S200-S181
6	2	Washer A8,4	D125-A84-S181
7	2	Tensioning ring VHD8	H60727-X80-R
8	7	Hexagonal screw M12x35	D933-U350-G181
9	14	Washer A13	D125-A130-S181
10	7	Tensioning ring VHD12	H60727-X120-R
11	7	Hexagonal nut M12	D934-A120-S181

Customer connection (items 2 to 6 are not part of the scope of supply)

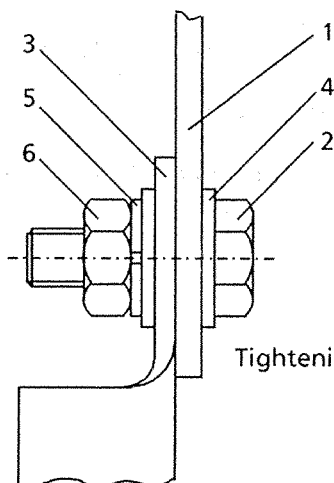

Tightening torque: 50Nm ± 15%

Material required for each connection:

Item	Qty.	Designation
1	1	Busbar
2	1	Hex. screw M12x35
3	1	Customer connection
4	2	Washer A13
5	1	Tensioning ring VHD12
6	1	Hexagonal nut M12

3.2 Position of boards, ribbon cables, control leads and terminal strips

Unit type D. / 30 - 600

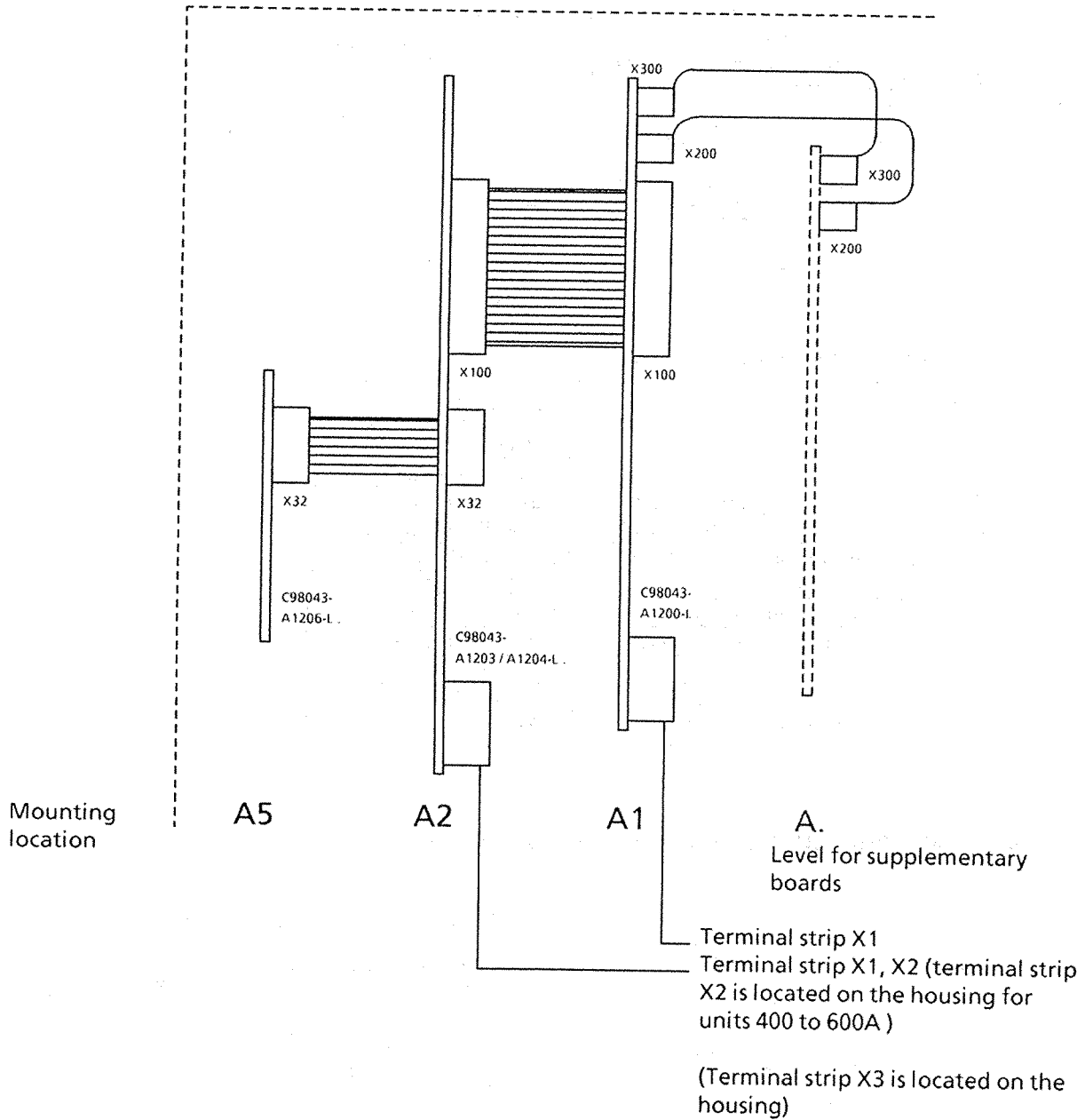

Unit type D. / 640 - 1200

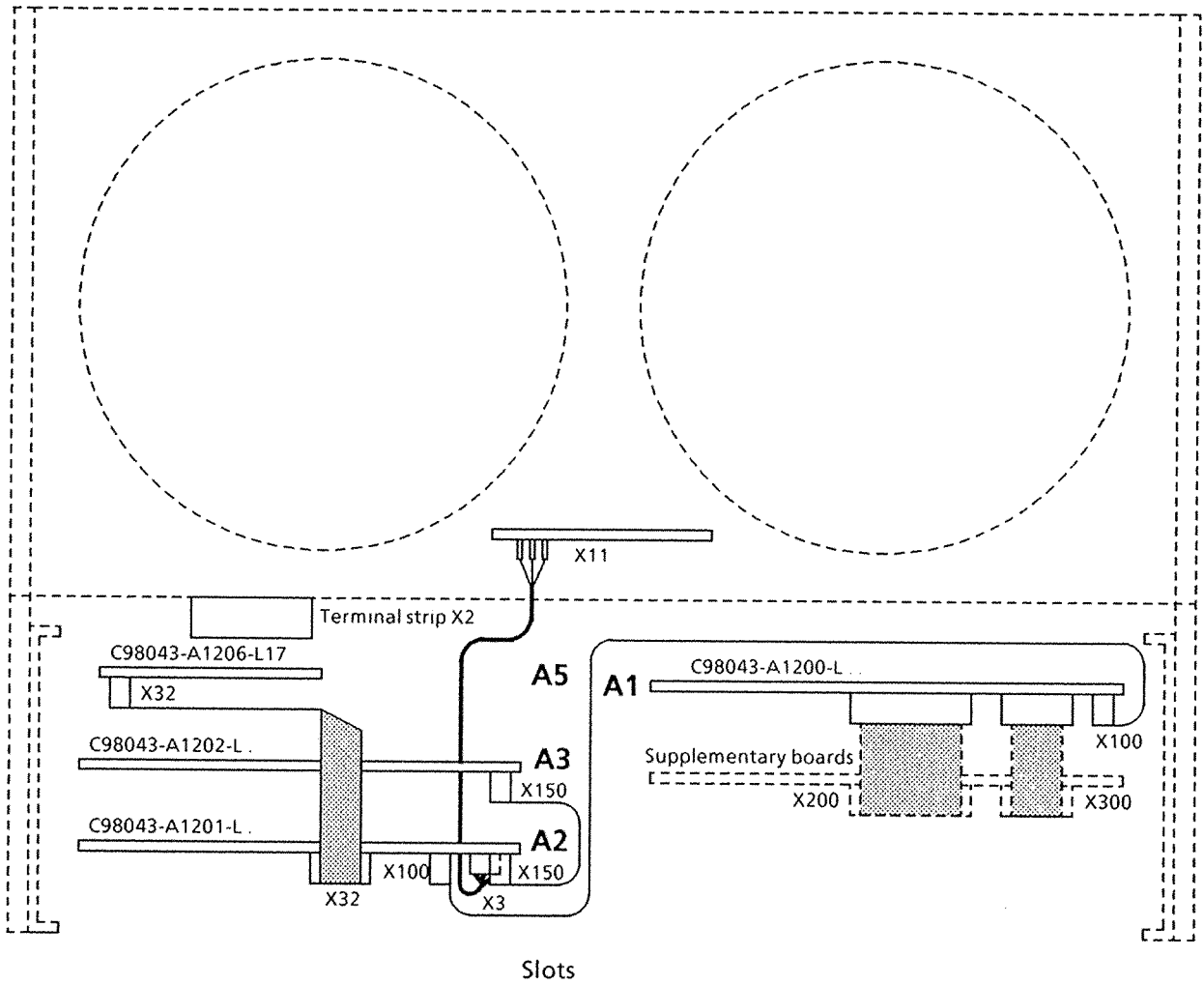

Plug connector for parallel SITOR set

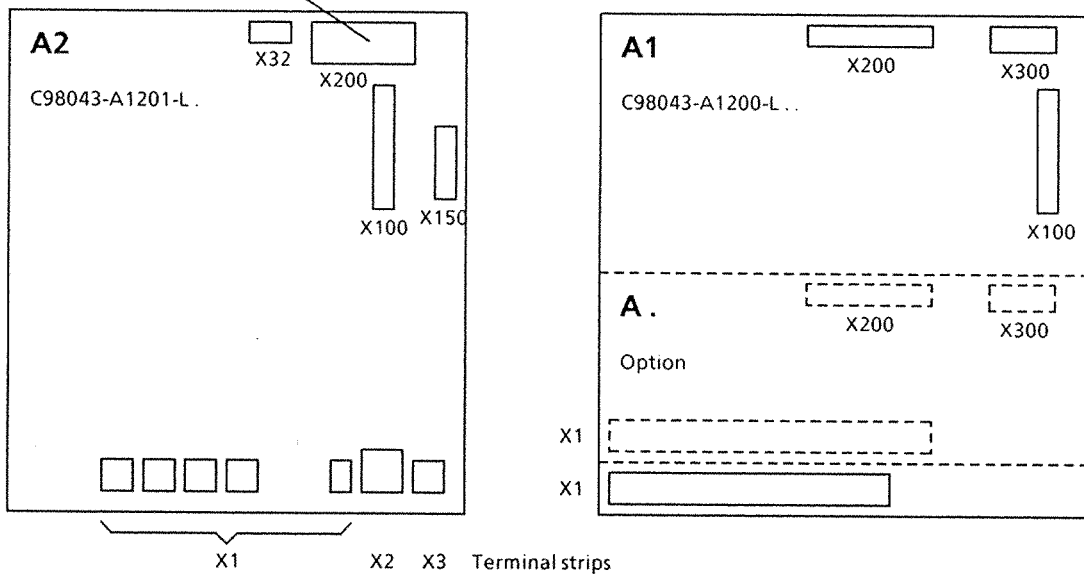

4. Connecting up



WARNING

This unit has hazardous voltages and dangerous rotating components (fans). Loss of life, severe personal injury or property damage can result if instructions contained in this manual are not followed.

Even when the converter main contactor is open, the unit has dangerous voltage levels. The control board (lower board) has many circuits at hazardous voltage levels.



The user has the responsibility for installing the converter, motor, transformer as well as other units in accordance with the relevant safety regulations (e.g. DIN, VDE) as well as all other relevant national or local regulations regarding cable dimensioning and protection, grounding, disconnect switch, overcurrent protection etc.

A dangerous voltage level can be available at the customer side, at signaling relays K1, K2 and K4 . . . K7 (K4 . . . K7 for supplementary board Z1210).

The units cannot be connected to a supply with ground-fault circuit interrupter (VDE 0160, Section 6.5), as a DC component can be included in the fault current in the case of a short-circuit or ground fault, which can either inhibit or prevent a higher-level ground-fault circuit interrupter from tripping. In this case, all loads connected to this ground-fault circuit interrupter are also not protected.

Braking the drive to a standstill via terminal 17 on A1200 (ON/STOP), terminal 18 on A1200 (controller enable) and/or terminal 8 on A1203 / A1204 or terminal 17 on A1201 (pulse cancellation) alone do not ensure a reliable operating stop in the sense of the valid regulations (DIN VDE 0113 Part 1). A fault in the converter electronics could cause an undesired motor start.



WARNING

The external surfaces of ungrounded converter units can have hazardous voltage levels. This can lead to loss of life, severe personal injury or property damage.



If the converter (cubicle unit or open-chassis unit) is installed so that it is not grounded, then for operating personnel safety, a ground conductor should be connected to the chassis or the housing. The motor frame, transformer housing and operating control section must also be grounded. The specific requirements regarding unit grounding should be taken from the applicable safety regulations (e.g. DIN, VDE) as well as all other relevant national or local regulations.

All accessible rotating parts and components must be provided with protective covers.

NOTE

In order to ensure interference immunity (EMC) the grounding screw of the unit should be connected conductively to the cubicle through the shortest possible route.

Connecting instructions for screened control cables

30A to 600A units

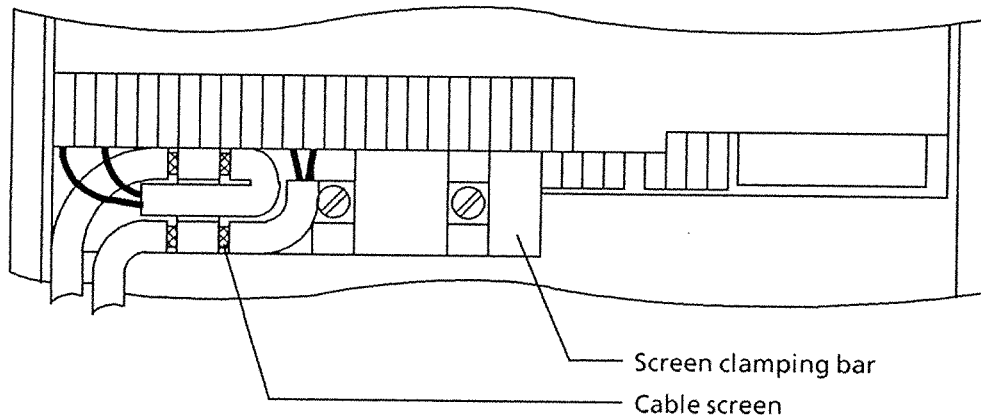

850A to 1200A units

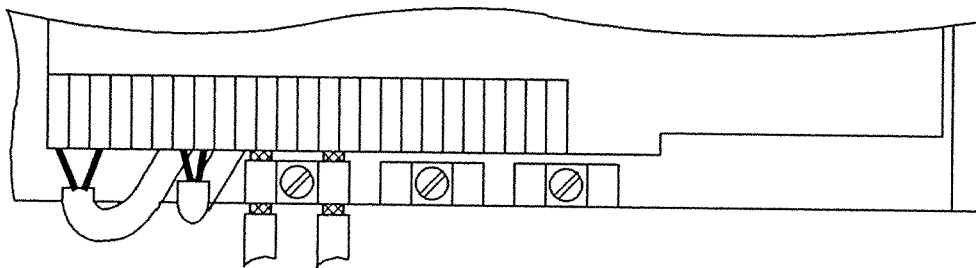

NOTE

It should be ensured that the voltage at terminals 1U-1V-1W has a clockwise phase sequence and has the same phase relationship as terminals 1U- 2U-3U, and 1W-2W-3W (fault message F02 occurs for a counter-clockwise phase sequence).

NOTE

The units should be connected up using the certified connecting terminal diagram or recommendation for connection. Setpoint and actual value cables are screened, and should be run separately from the power cables. Control cables and field supply cables must be routed in separate cable ducts.

When the unit is connected according to Section 4.1, the DC output is not electrically isolated from the supply.

4.1 Block diagram with recommended connection

Unit type D. / 30 - 600

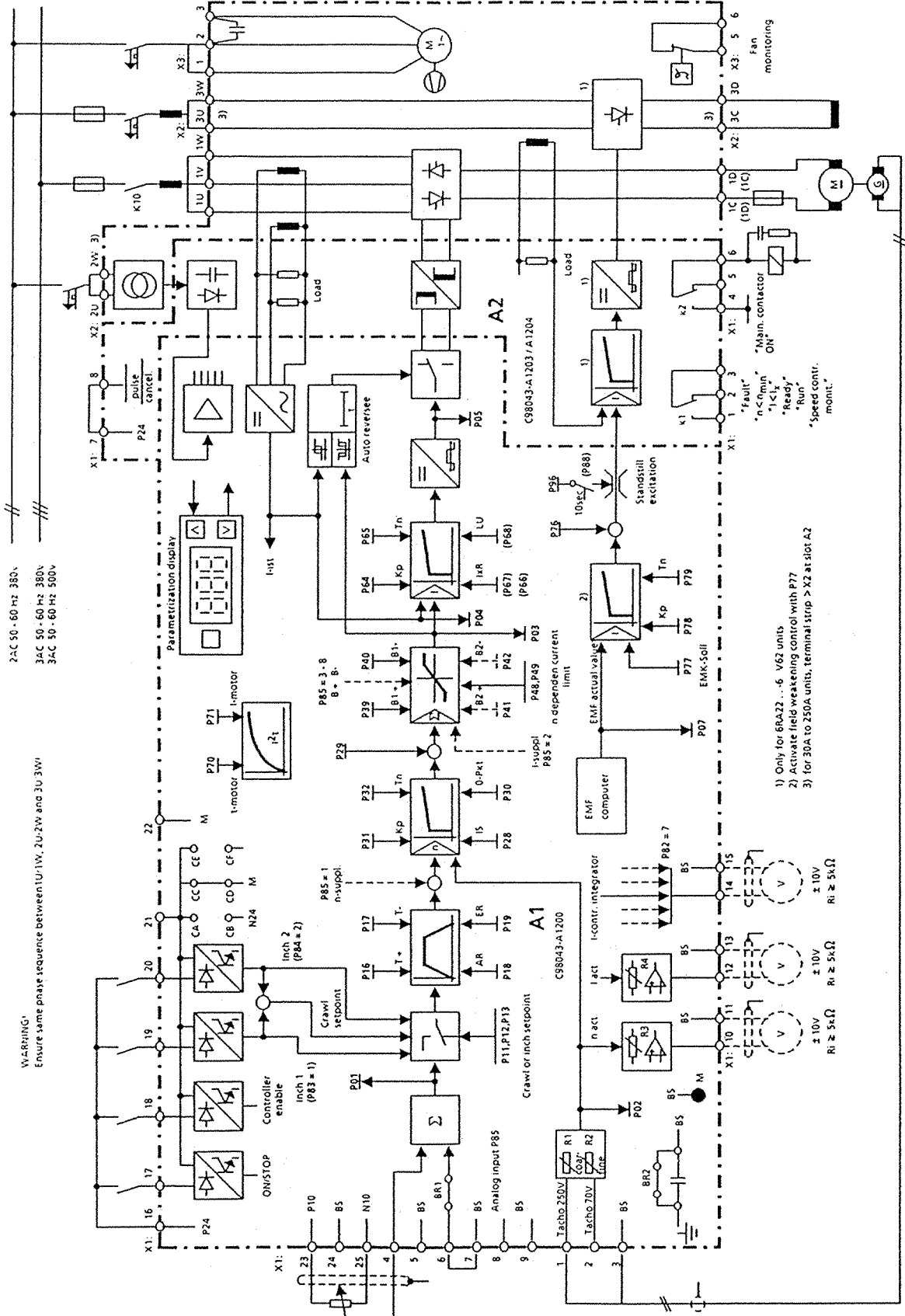

Unit type D. / 640 - 1200 (without excitation rectifier)

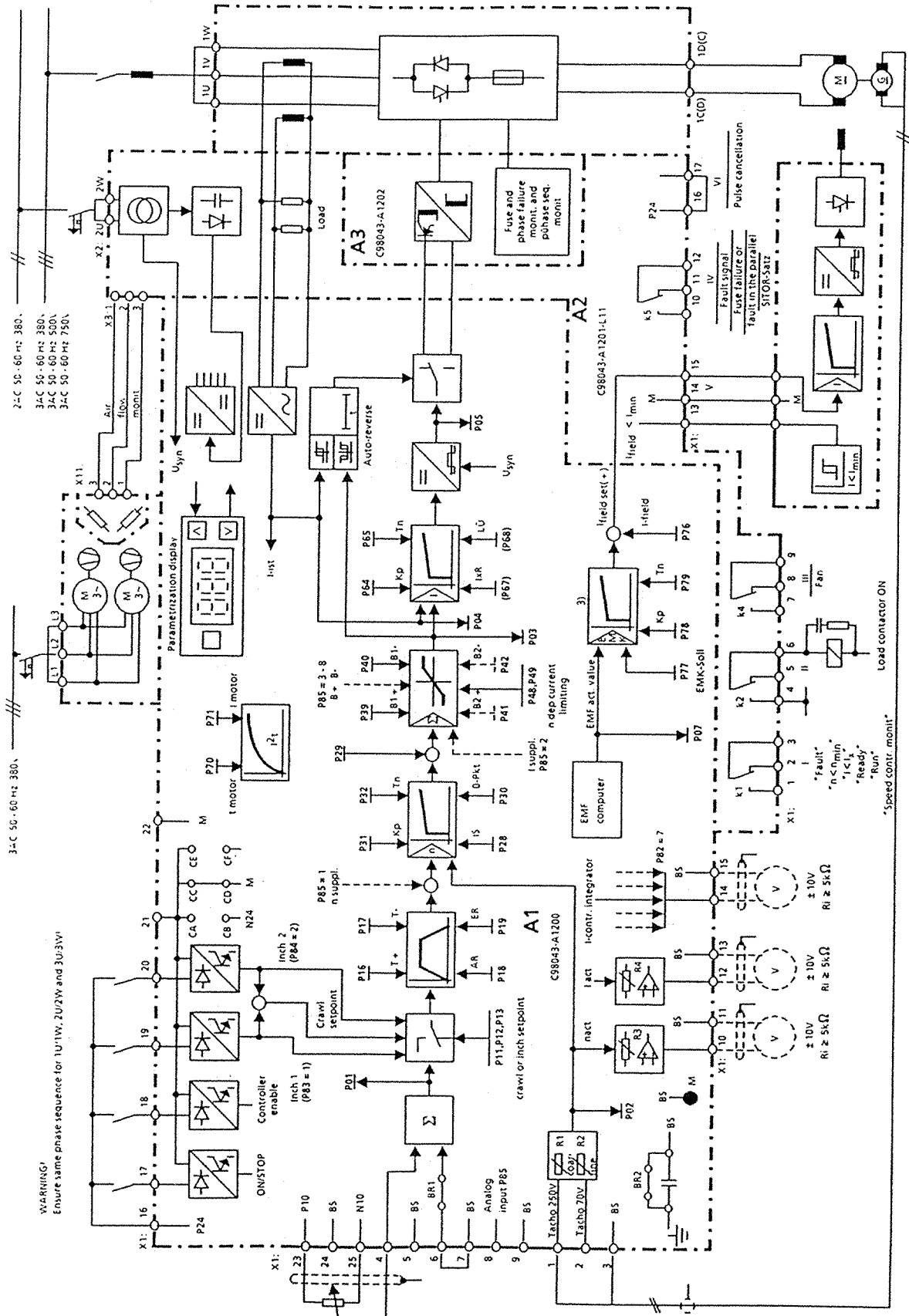

4.1.1 Connection schematic for a SIMOREG unit in parallel with a 6QG25 SITOR thyristor set

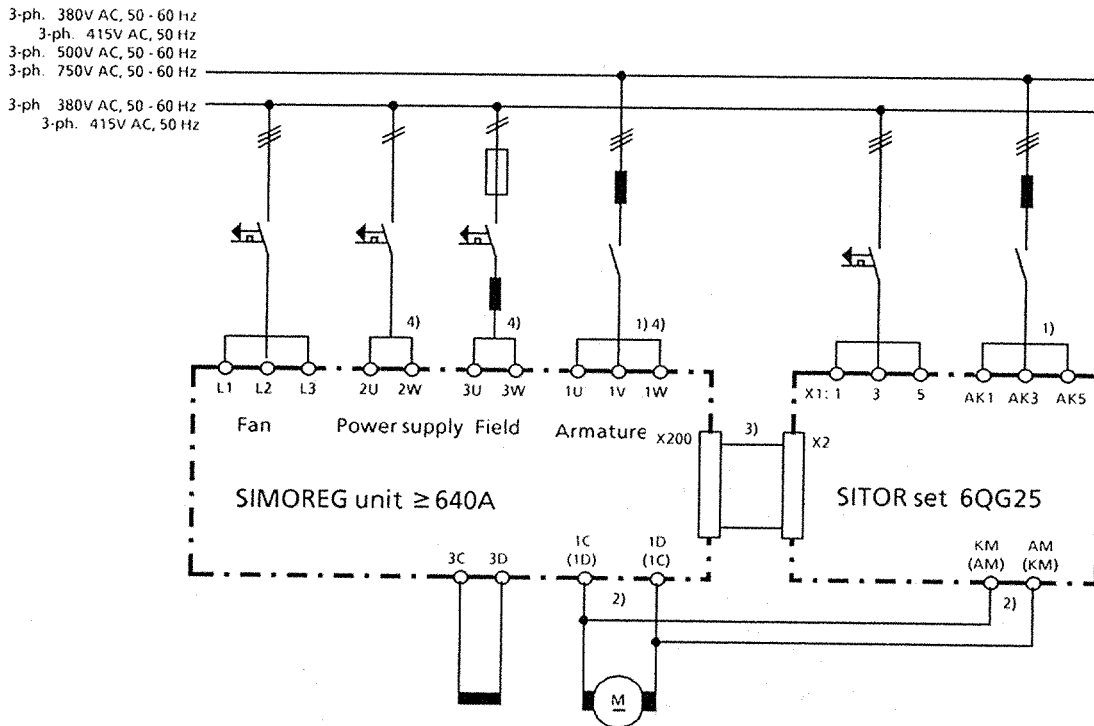

- 1) 1U / 1V / 1W and AK1 / AK3 / AK5 should have the same phase sequence.
- 2) 1C / 1D and KM / AM should have the same phase sequence.
- 3) Ribbon cable C98130-A1065-B403, X200 on board A1201 (A2) to X2 on SITOR set
- 4) 2U / 2W, 3U / 3W and 1U / 1W should have the same phase sequence.

Separate commutating reactors for the SIMOREG unit and SITOR set are required for current distribution.

Caution, only units having the same current rating should be connected in parallel!

Permissible output current for parallel circuit configuration:

- a) For configurations with SIMOREG and SITOR on top of each other with common fan assembly
 $I_{max} = 2 \times I_N(\text{SIMOREG}) \times 0.85$
- b) For configurations with SIMOREG and SITOR next to each other with separate fan assembly
 $I_{max} = 2 \times I_N(\text{SIMOREG})$

Setting parameter P71 (motor rated current/unit rated current):

$$P71 = \frac{\text{Rated motor current}}{2 \times \text{unit rated current of the 6RA22 converter}} \times 100 \%$$

Setting parameters P39 and P40 (current limit):

$$\text{Maximum value of P39 / P40} = \frac{I_{max}}{\text{Motor rated current}} \times 100 \%$$

I_{max} should be reduced, corresponding to Section 2 for ambient temperatures exceeding 35° C and installation altitudes exceeding 1000 m.

NOTE

It is recommended that the closed-loop current controller is manually optimized (refer to Section 5.6).

4.2 Power connections Unit type D. / 30 - 600

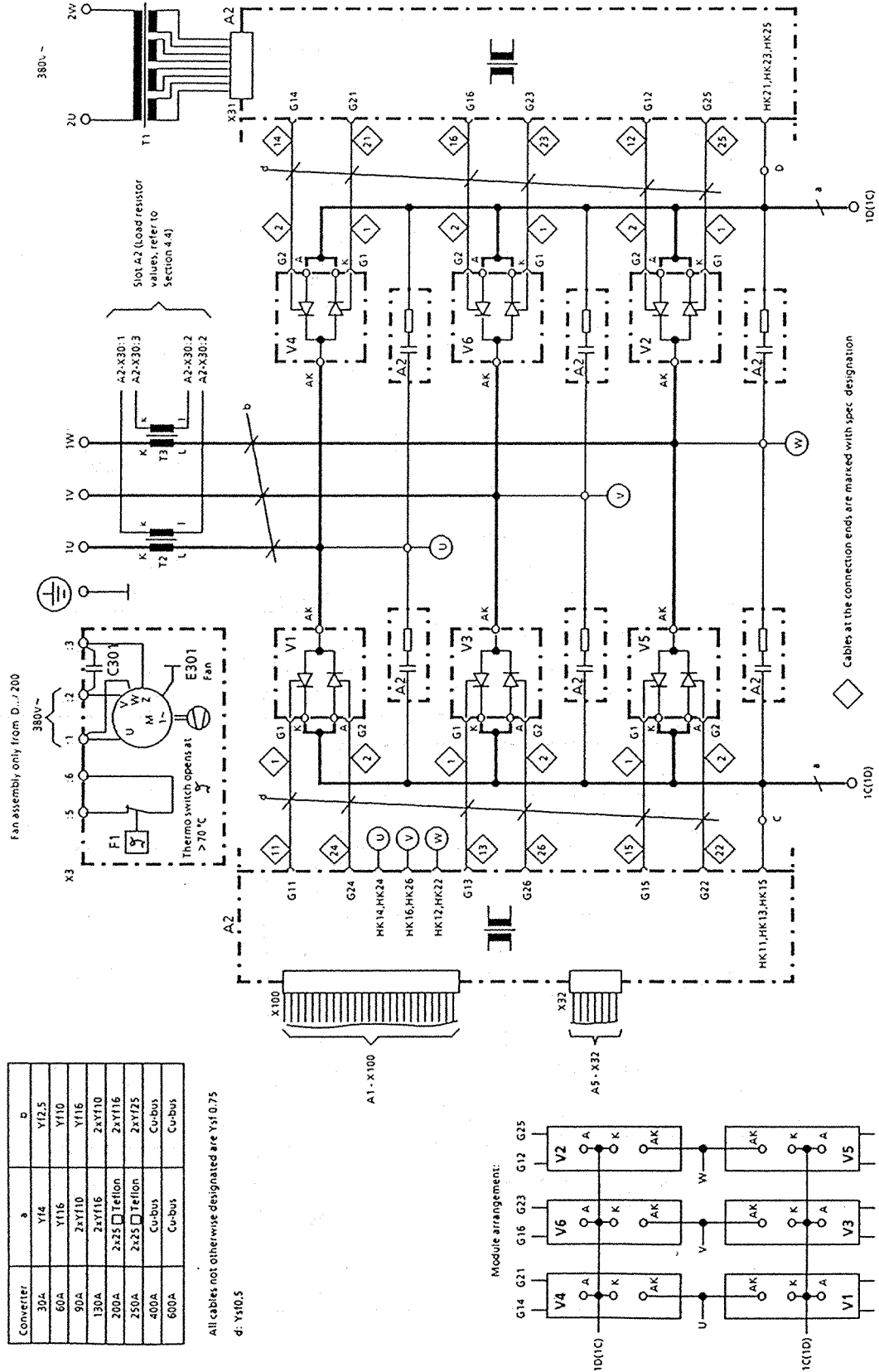

Unit type D. / 640 - 1200

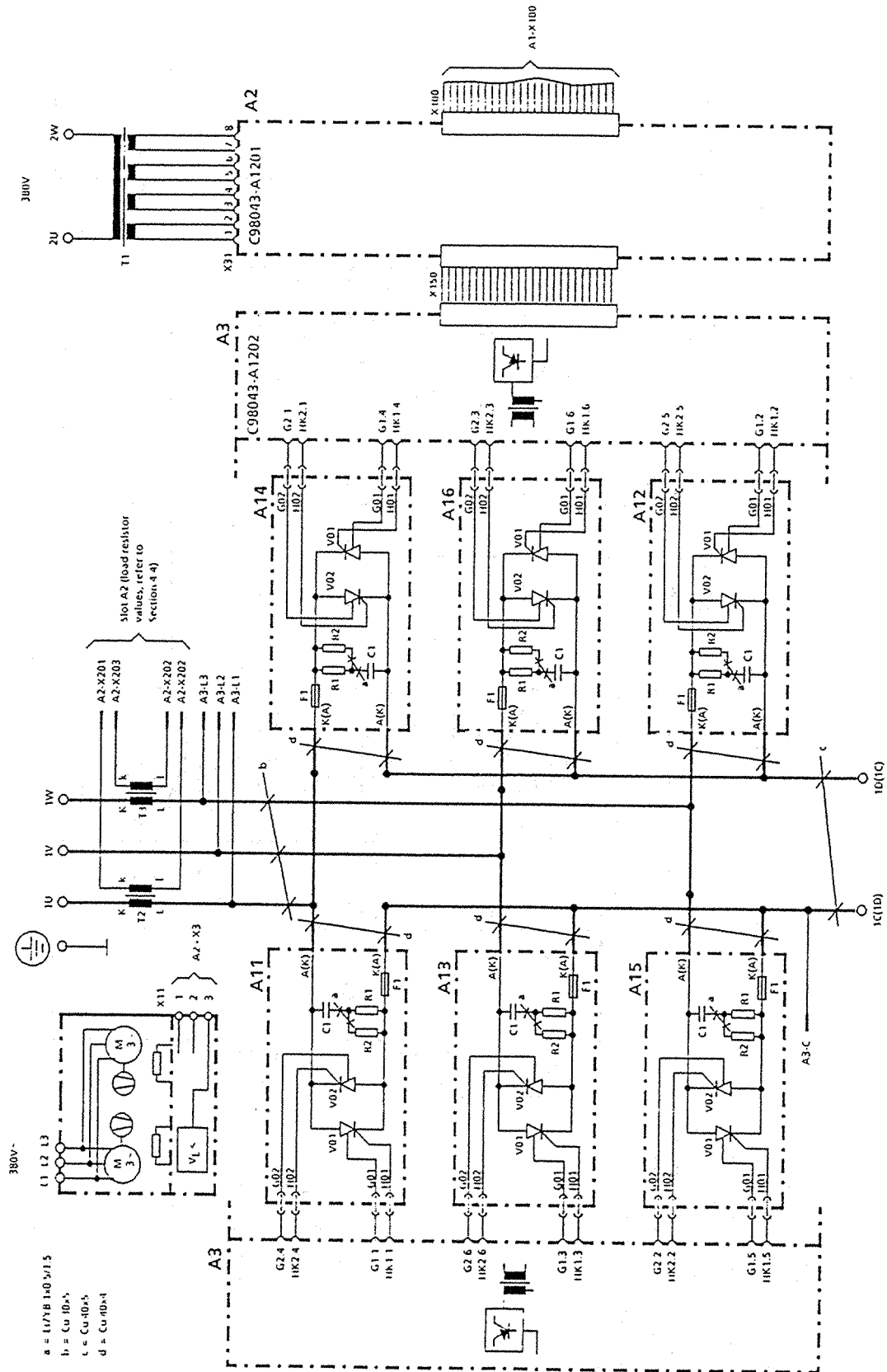

4.3 Field supply

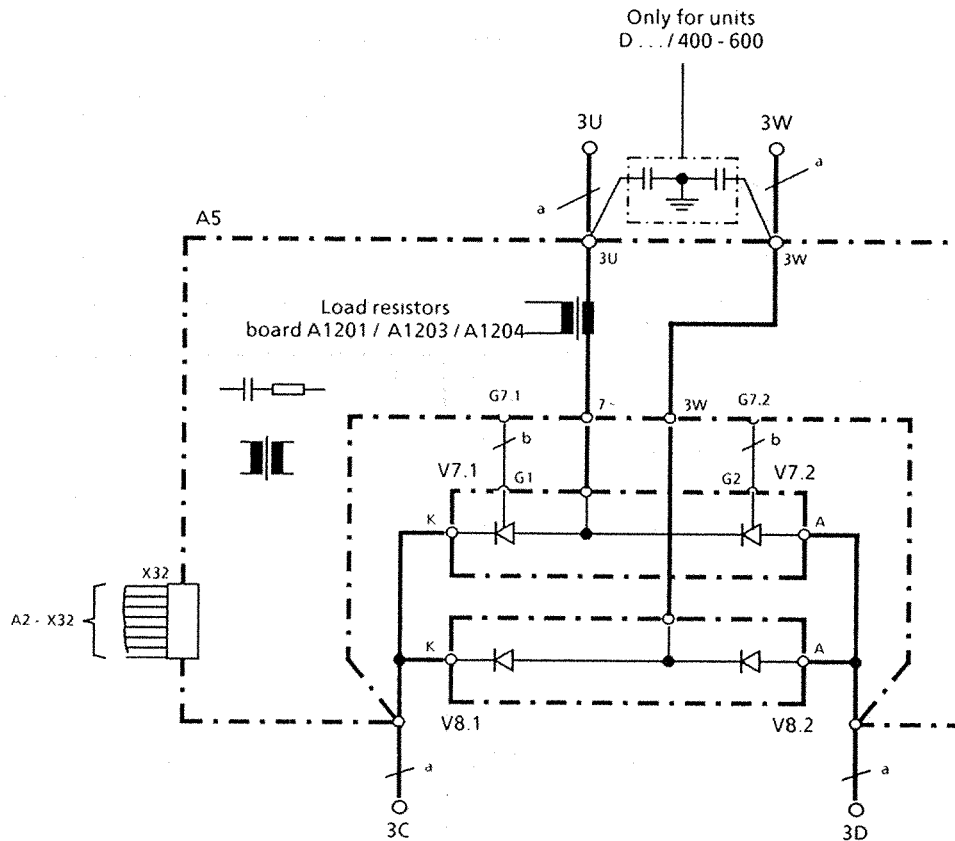

4.4 Load resistors (refer to the following pages for position)

IMPORTANT NOTE

No liability can be accepted for damage incurred due to the installation of the wrong load resistors.

The current transformers will be destroyed if the armature circuit load resistors (R17 to R20) are not installed.

Replacement boards are supplied without load resistors!

The unit can be adapted to lower current ratings by removing load resistors according to the following table. In order to attain a correct optimization run, the load resistors must be adjusted if the ratio of -- motor rated current/converter rated current ≤ 0.3 -- . This is valid for the armature as well as for the field excitation circuit.

Load resistors for armature circuit on A2						Load resistors for field circuit on A2				
Converter rated current	Reduced rated current	Current transformer ratio	Load resistors on A2		Effective value	Field rated current	Reduced field current	Load resistors on A2		Effective value
			Tolerance: 0.5%					R51	R52	
			1) R17, R19	2) R18 R20						
A	A	1 :	Ω	Ω	Ω	A	A	Ω	Ω	Ω
30	-	2000	267	88.7	66.58	5	-	1.8k	680	493.5
-	22.5	2000	-	88.7	88.7	-	3.7	-	680	680
-	7.5	2000	267	-	267	-	1.4	1.8k	-	1.8k
60	-	5000	332	111	83.19	10	-	3k	1.5k	1k
-	45	5000	-	111	111	-	6.7	-	1.5k	1.5k
-	15	5000	332	-	332	-	3.3	3k	-	3k
90	-	5000	180	75.9	56.0	-	-	-	-	-
-	66	5000	-	75.9	75.9	-	-	-	-	-
-	28	5000	180	-	180	-	-	-	-	-
130	-	5000	100	61.2	37.69	-	-	-	-	-
-	82	5000	-	61.2	61.2	-	-	-	-	-
-	50	5000	100	-	100	-	-	-	-	-
200	-	5000	75.9	37.4	25.05	15	-	2k	1k	666.6
-	134	5000	-	37.4	37.4	-	10	-	1k	1k
-	66	5000	75.9	-	75.9	-	5	2k	-	2k
250	-	5000	61.2	29.4	19.85	-	-	-	-	-
-	170	5000	-	29.4	29.4	-	-	-	-	-
-	82	5000	61.2	-	61.2	-	-	-	-	-
400	-	2000	20.5	6.65	5.02	25	-	1k	680	404.7
-	300	2000	-	6.65	6.65	-	15	-	680	680
-	98	2000	20.5	-	20.5	-	10	1k	-	1k
600	-	2000	13.3	4.42	3.32	-	-	-	-	-
-	452	2000	-	4.42	4.42	-	-	-	-	-
-	150	2000	13.3	-	13.3	-	-	-	-	-
640	-	600	3.74	1.24	0.931	25	-	1.6k	560	414.8
-	484	600	-	1.24	1.24	-	18.5	-	560	560
-	160	600	3.74	-	3.74	-	6.5	1.6k	-	1.6k
850	-	600	2.8	0.942	0.705	-	-	-	-	-
-	637	600	-	0.942	0.942	-	-	-	-	-
-	214	600	2.8	-	2.8	-	-	-	-	-
860	-	600	2.77	0.931	0.697	-	-	-	-	-
-	644.5	600	-	0.931	0.931	-	-	-	-	-
-	216.6	600	2.77	-	2.77	-	-	-	-	-
1200	-	600	2.0	0.665	0.499	-	-	-	-	-
-	902	600	-	0.665	0.665	-	-	-	-	-
-	300	600	2.0	-	2.0	-	-	-	-	-

- 1) R17 and R19 always have the same value, and must be removed as a pair.
- 2) R18 and R20 always have the same value, and must be removed as a pair.

Location of load resistors and plug connections
(unit type D . / 30 - 600)

Board A1

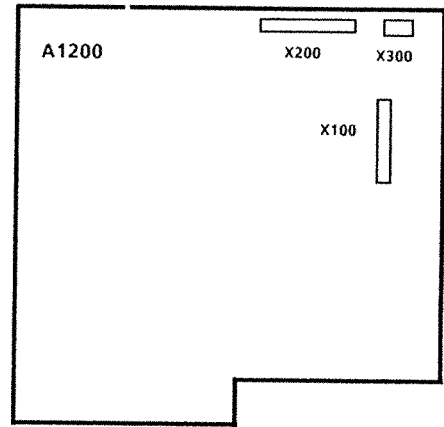

The load resistors for 30A to 250A units are located on solder pins on board A2 as follows.

Board A2

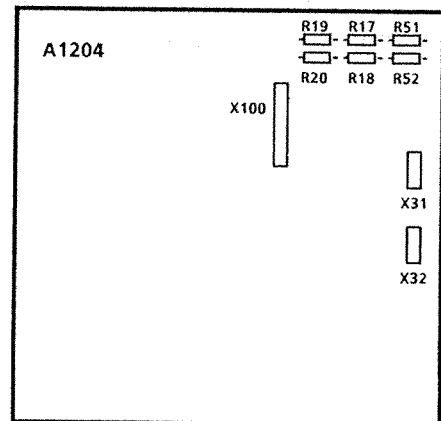

The load resistors for 400A to 600A units are located on solder pins on board A2 as follows.

Board A2

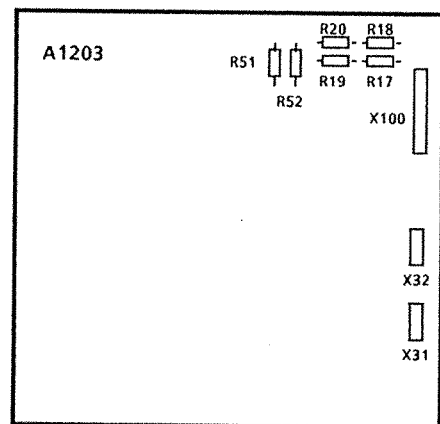

Location of load resistors and
plug connections (unit type D . / 640 - 1200)

Board A1

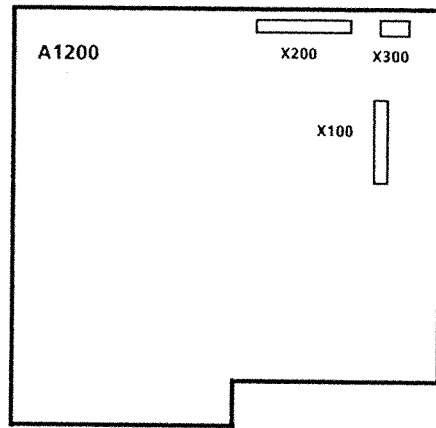

The load resistors are located on solder points on
board A2 as follows.

Board A2

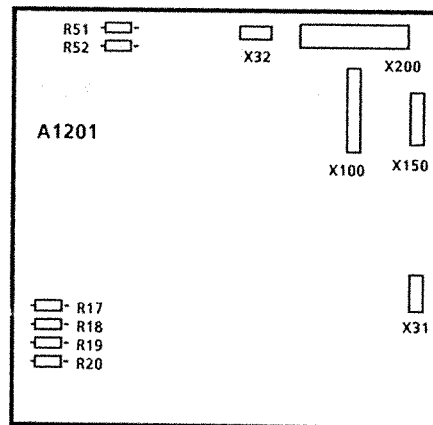

Board A3

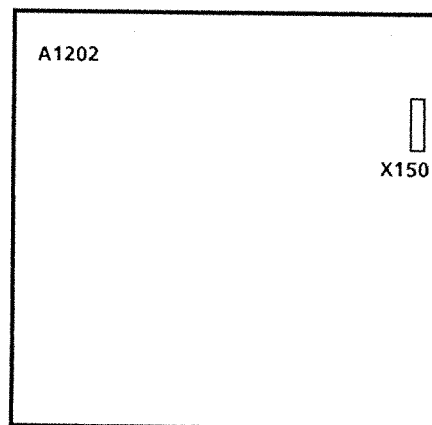

4.5 List of fuses and commutating reactors

Specified fuses and recommended commutating reactors for the armature circuit converter
(refer to the unit rated current)

Converter Order No.	Fuses		DC fuse Order No.	Commutating reactor for operating the equipment with approx. 80% of the rated unit current		for operating the equipment with approx. 100% of the rated unit current			
	Line fuse Order No.	Order No.		Order No.	Cont. DC current A	Cont. output kW	Order No.	Cont. DC current A	Cont. output kW
6RA2218 - 6DV62	3NE8003		3NE8003	4EM5000 - 3CB	30	12	4EM5000 - 3CB	30	12
6RA2225 - 6DV62	3NE8017		3NE8018	4EP3800 - 2DB	49	20	4EP3900 - 0DB	60	24
6RA2228 - 6DV62	3NE8020		3NE8021	4EP3900 - 2DB	77	31	4EP4000 - 1DB	90	36
6RA2232 - 6DV62	3NE8022		3NE8024	4EP4000 - 3DB	98	39	4EP4108 - 3CB	130	52
6RA2275 - 6DV62	3NE8024		3NE4327 - 0B	4EP4108 - 0CB	170	68	4EP4108 - 6CB	195	78
6RA2277 - 6DV62	3NE4327 - 0B		3NE4327 - 0B	4EP4108 - 1CB	195	78	4EP4205 - 0CB	244	98
6RA2281 - 6DV62	3NE4333 - 0B		3NE4333 - 0B	4EP4204 - 7CB	341	136	4EP4308 - 1CB	400	160
6RA2285 - 6DV62	3NE4334 - 0B		3NE4337	4EP4307 - 8CB	488	195	4EP4410 - 5CB	600	240
6RA2218 - 6GV62	3NE4102		3NE4102	4EP3700 - 1DB	30	16	4EP3700 - 1DB	30	16
6RA2225 - 6GV62	3NE4118		3NE4118	4EP3800 - 4DB	49	25	4EP4000 - 2DB	60	31
6RA2228 - 6GV62	3NE4121		3NE4121	4EP4000 - 4DB	77	40	4EP4900 - 4CB	87	45
6RA2232 - 6GV62	3NE4122		3NE4124	4EP4108 - 7CB	110	57	4EP4110 - 2CB	130	68
6RA2275 - 6GV62	3NC8423 - 3		3NC8425	4EP4205 - 3CB	170	88	4EP4205 - 8CB	183	95
6RA2277 - 6GV62	3NE4327 - 0B		3NE4327 - 0B	4EP4205 - 4CB	195	101	4EP4206 - 1CB	244	127
6RA2281 - 6GV62	3NE4333 - 0B		3NE4333 - 0B	4EP4308 - 2CB	305	158	4EP4411 - 2CB	400	208
6RA2285 - 6GV62	3NE4334 - 0B		3NE4337	4EP4410 - 7CB	488	254	4EP4508 - 6CB	600	312

**Recommended commutating reactors for the armature circuit converter (refer to unit rated current)
External fuses are not required**

Converter unit Order No.	Branch fuses included in the converter Order No.	Commutating reactor for operating the equipment with approx. 80% of the rated unit current		Commutating reactor for operating the equipment with approx. 100% of the rated unit current			
		Order No.	Continuous DC current A	Cont. output kW	Order No.	Continuous DC current output A	Cont. output kW
6RA2287-4DV6.	3NE4334-0B	4EP4410 - 3CB	683	273	4EP4508 - 5CB	850	340
6RA2291-4DV6.	3NE4337	4EP4508 - 4CB	975	390	4EP4612 - 2CB	1200	480
6RA2287-4GV6.	3NE4334-0B	4EP4411 - 0CB	683	355	4EP4612 - 4CB	850	442
6RA2291-4GV6.	3NE4337	4EP4612 - 3CB	975	507	4EP4700 - 7CB	1200	624

660V power section supply voltage

6RA2285-4KV6.	6QX5314	4EP4512 - 0CB	549	384	4EP4612 - 6CB	640	448
6RA2287-4KV6.	6QX5316	4EP4510 - 0CB	683	478	4EP4613 - 5CB	860	602

750V power section supply voltage

6RA2285-4KV6.	6QX5314	4EP4511 - 6CB	549	434	4EP4613 - 7CB	640	505
6RA2287-4KV6.	6QX5316	4EP4511 - 8CB	683	539	4EP4701 - 1CB	860	679

Recommended fuses and commutating reactors for the excitation circuit converter
(only for version V62)

Converter rated DC current A	Field excitation rectifier		Fuse Order No.	Rated current A	Commutating reactor Order No.
	Rated supply voltage V	Max. permissible excitation current A			
30	1 ~ 380	5	5SD420	16	4EM4807 - 1CB
60 to 130		10	5SD420	16	4EM4911 - 7CB
200 to 250		15	5SD440	25	4EM5000 - 2CB
400 to 600		25	5SD440	25	4EM5100 - 2CB
640 to 1200		25	5SD440	25	4EM5100 - 2CB

NOTE

Thyristor protection cannot be guaranteed if fuses, other than those specified in the operating instructions, are used.

4.6 Terminal assignment



WARNING



The unit can either be damaged or destroyed when incorrectly connected.

Power connection

Terminal type: 30 A unit
60 A to 250 A units
400A to 600A units
640A to 1200A units

Terminal BK16 (10 mm² cross-section)
Threaded bush M8 in 20 mm wide Cu rail
Threaded bush M10 in 25 mm wide Cu rail
The power connections are located at the rear of the SIMOREG unit. The location of the main connections can be taken from the dimension drawing. For cubicle installation, the rear main connections are only accessible when the cubicle has a rear door. Front connection is possible using a connecting piece set. The connecting cable on the DC and AC side should be selected according to DIN VDE 0298. Cable lugs should be used. They should be attached, without using washers or tensioning washers on the thyristor set side of the rails.

Terminal	Circuit diagram Section 4.1-4.3	Function
1U		Thyristor set-supply connection
1V		
1W		
1C (1D)		Armature circuit - motor connection
1D (1C)		

Fan connection (for separately ventilated units 200 A to 600 A)

Terminal strip X3 (on the housing)

Terminal type: G5 / G6 unit terminal (screw terminals) on the connecting strip, maximum conductor cross-section: 4 mm²

Terminal	Circuit diagram Section 4.1-4.3	Function
1		Fan, 2-ph. 380 V AC; 0.45A
2		
3		Internally used; motor capacitor
4		Not used
5		Temperature monitoring (opens when the heatsink has an overtemperature condition)
6		

Fan connection (for separately ventilated units 640 A to 1200 A)

Terminal strip X3 (at slot A2 and fan assembly, refer to Section 3.2)

Terminal type: Faston, 6.3 x 0.8 mm

Terminal	Circuit diagram Section 4.1-4.3	Function
L1		Fan 3-ph. 380 V AC; 0.68A
L2		
L3		



WARNING

The unit can overheat when the phase sequence is incorrect (fan rotates in the wrong direction).

Connecting the output relay, pulse inhibit (for 30 A to 600 A units)

Terminal strip X1 (at slot A2, refer to Section 3.2)

Terminal type: Plug-in terminals in blocks
(in the list, the blocks are separated by =)
The blocks can be individually removed
Maximum conductor cross-section: 1.5 mm²

Terminal	Circuit diagram Section 4.1-4.3	Function
1	NO contact	Output relay K1: Function can be selected P80 = 0: Relay drops out for a fault condition (as supplied) 1: Relay pulls in at $n < n_{min}$; n_{min} selectable at P21 2: Relay pulls in at $i < i_{min}$; i_{min} selectable at P47 3: Relay pulls in at ol, --, I or II 4: "Drive operational" signal 5: "Speed controller monitoring" signal
2	NC contact	
3	Common	
4	NO contact	Output relay K2 for load contactor "On" pulls-in at command "On" (P24 at terminal 17)
5	NC contact	
6	Common	
7		Non-stabilized power supply + 18 V to + 30 V Pulse enable + 18 V to + 30 V (25 mA)
8		
		When supplied, X1.7 is connected to X1.8 (otherwise continuous pulse cancellation)

Relay contact load capability: ≤ 240 V AC, 3 A (at $\cos \phi = 0.3 : 1A$)
 ≤ 100 V = 3 A

Connecting the output relay, pulse inhibit, monitoring functions

(for 640 A to 1200 A units)

Terminal strip X1 (at slot A2, refer to Section 3.2)

Terminal type: Plug-in terminals in blocks

(in the list, the blocks are separated by =)

The blocks can be individually removed

Maximum conductor cross-section : 1.5 mm²

Terminal	Circuit diagram Section 4.1-4.3	Function
1	NO contact	Output relay K1: Function selectable P80 = 0: Relay drops out for a fault condition (as supplied) 1: Relay pulls in for $n < n_{min}$; n_{min} selectable with P21 2: Relay pulls in at $i < i_{min}$; i_{min} selectable with P47 3: Relay pulls in at ol, --, I or II 4: "Drive operational" signal 5: "Speed controller monitoring" signal
2	NC contact	
3	Common	
4	NO contact	Output relay K2 for load contactor "On" pulls-in at command "On" (P24 at terminal 17)
5	NC contact	
6	Common	
7	NO contact	Output relay K4 fan, airflow monitoring Relay pulls-in under fault conditions
8	NC contact	
9	Common	
10	NO contact	Output relay K5 fault signal Fault in the parallel SITOR set ²⁾ relay drops out under fault conditions (refer to fault F21)
11	NC contact	
12	Common	
13 ¹⁾	$I_{Field} \leq I_{min}$	Output from the external field supply unit $L \leq 3.5V$ or open-circuit terminal $6V \leq H \leq 30V$ corresponds to a fault
14 ¹⁾	M	Ground
15 ¹⁾	$I_{Field set (+)}$	Field current setpoint output maximum field current corresponds to + 10V
16	P24	Unstabilized power supply + 18V to + 30V
17	Pulse cancellation Rel	+ 18V to + 30V (25mA) corresponds to pulse enable

- 1) Only available for converters without field unit (version V60). The external field unit can be treated just like the field unit incorporated in the converter itself (version V62).
- 2) SITOR set fault: Fuse failure, undervoltage, overtemperature
 Pulse inhibit realized when the fuse monitoring responds.

Relay contact loading capability: ≤ 240 V AC, 3 A (at $\cos \phi = 0.3 : 1A$)
 ≤ 100 V DC, 3 A

X1.16 is connected with X1.17 when supplied

Connecting the airflow monitoring (for units $\geq 640A$)

Terminal strip X3 (Unit-internal connection from slot A2 to fan module, refer to Section 3.2)

Terminal type: Plug-in terminals at A2
 Maximum conductor cross-section: 1.5 mm² and
 Faston connections 6.3 x 0.8 on the fan assembly

Terminal	Circuit diagram section 4.1-4.3	Function
1	Airflow monitoring	Airflow v_L too small \Rightarrow H signal
2	M	Ground
3	P24	Unstabilized power supply + 18V to + 24V

Connecting the electronics

Terminal strip X1 (at slot A1, refer to Section 3.2)

Terminal type: Plug-in terminals in blocks
 (in the list the blocks are separated by =)
 maximum conductor cross-section: 1.5 mm²

Screen: Screens are electrically connected to ground through the strain relief rail

Terminal	Circuit diagram section 4.1-4.3	Function
1		Speed act. val. input, max.250V, 46k Ω (can be set between 30-250V)
2		Speed act. value input, max.70V, 13.3k Ω (can be set between 8-70V)
3		Reference potential 0 V
4		Ramp-function generator - setpoint input ± 10 V, 10 k Ω The ramp-function generator input is internally limited to 105% of the maximum speed (normalization: Parameter E01) ¹⁾
5		Reference potential 0 V
6		Ramp-function generator - setpoint input ± 10 V, 10 k Ω , add. to terminal 4. The ramp-function generator input is internally limited to 105% of the maximum speed (normalization: Parameter E01) ¹⁾
7		Reference potential 0 V

¹⁾ Parameter E01 influences the speed actual value adjustment in the same ratio (terminal X1.1/2). Thus, it is necessary to set E01 before adjusting the max. speed and the field characteristic test.

Terminal	Circuit diagram Section 4.1-4.3	Function
8		<p>Analog input $\pm 10\text{ V}$, $60\text{ k}\Omega$ (normalization: Parameter E02) Function can be selected via parameter 85</p> <p>P85 = 0: no function (as supplied)</p> <p>1: Speed controller supplementary setpoint Caution: The sum of the ramp-function generator output and the speed controller supplementary setpoint (this acts <u>after</u> the ramp-function generator) is limited to 105% of the maximum speed (from software release 3.2 onwards). [-10V x E02: 100 ... + 10V x E02: 100 = -100% ... + 100%]</p> <p>2: Current controller supplementary setpoint The applied analog value is interpreted as additional current setpoint, referred to the rated unit current, and is added to the speed controller output. [-10V x E02: 100 ... + 10V x E02: 100 = -100% ... + 100%]</p> <p>3: External current limiting, positive direction The magnitude of the applied analog value is interpreted as positive current limit. [10V x E02: 100 = current limit 1 (maximum of P39 and P40)]</p> <p>4: External current limiting, negative direction The magnitude of the applied analog value is interpreted as negative current limit. [10V x E02: 100 = current limit 1 (maximum of P39 and P40)]</p> <p>5: External current limiting, positive and negative direction The magnitude of the applied analog value is interpreted as current limit. [10V x E02: 100 = current limit 1 (maximum of P39 and P40)]. The positive and negative current limiting values are changed in parallel.</p> <p>6: No function</p> <p>7: External current limiting, with sign, positive direction The magnitude of the applied analog value is interpreted as positive current limit. [+ 10V x E02: 100 = current limit 1 (maximum of P39 and P40)]. A negative value signifies a <u>lower</u> current limit for torque direction II.</p> <p>8: External current limiting, with sign, negative direction The magnitude of the applied analog value is interpreted as negative current limit. [+ 10V x E02: 100 = current limit 1 (maximum of P39 and P40)]. A negative value signifies a <u>lower</u> current limit for torque direction I.</p> <div style="border: 1px solid black; padding: 5px; margin-top: 10px;"> <p>NOTE</p> <p>With parameter setting P85 = 7 or 8, negative values at terminal 8 act as current setpoints for the opposing torque direction. The motor can also accelerate in the opposite direction for $n^* = 0$.</p> </div>

Terminal	Circuit diagram section 4.1-4.3	Function
8		<p>P85 = 9: Analog field current setpoint The magnitude of the applied analog value is used as field current setpoint. It refers to P76. [10V x E02: 100 = field current as per P76] automatic field weakening is not possible in this mode.</p> <p>10: Analog EMF actual value:10V Input for external EMF sensing [-10V x E02: 100 ... + 10V x E02: 100 = - EMF as per P98 ... + EMF as per P98]</p> <p>11: Current setpoint [± 10V x E02: 100 ÷ rated equipment current] If current-controlled operation is selected through a selector terminal (e.g. terminal 19, refer to P83 = 9 and 11), the current setpoint is taken from terminal 8. In this case, terminals 4 and 6 are ineffective.</p>
9		Reference potential 0 V
10		Speed actual value display (± 10 V / 2 mA) adjustable through potentiometer R3; (0.6 to 1.6) x 10V, polarity corresponding to the tachometer voltage
11		Reference potential 0 V
12		<p>Current actual value display (either as magnitude, or as output with sign, ± 10 V / 2 mA), adjustable through R4; (0.5 to 1.1) x 10V corresponds to the rated unit current.</p> <p>P86 = 0: Current actual value display with sign: + → M1 (as supplied)</p> <p>1: Magnitude of the current actual value is displayed 2: Inverted current actual value display with sign 3: Magnitude of the current actual value, inverted</p>
13		Reference potential 0 V
14		<p>Analog output ± 10 V / 2 mA ; Function can be selected via P82 The normalization specified in brackets is valid for E67 = 1.0. Otherwise, the value should be multiplied with E67. e.g. for P82 = 8, then 10V = 510V EMF x parameter E67 is valid</p> <p>P82 = 0: 0 V</p> <p>1: Speed controller setpoint - actual value difference (10V = 200% of the maximum speed)</p> <p>2: Speed controller output (8V = 100% of the rated unit current)</p> <p>3: Magnitude of the current setpoint (8V = 100% of the rated unit current)</p> <p>4: Ramp-function generator output (10V = 100% of the maximum speed)</p> <p>5: Actual speed value (8V : P72 = 100% of the maximum speed)</p> <p>6: Motor loading (8V = 100% loading)</p> $8V \times \frac{ EMF_{act} }{EMF_{set} (= P77)} \times \frac{ I_{act} }{I_{max} \text{ (actual current limit)}}$

Terminal	Circuit diagram section 4.1-4.3	Function
14		<p>P82 =</p> <ul style="list-style-type: none"> 7: Current controller - integrator (as supplied) (10V $\hat{=}$ 5.62° firing angle) 8: EMF (10V = 510V EMF) 9: Diagnostics function (for factory internal purposes) 10: Actual current limit (8V = 100% rated unit current) 11: Magnitude of the speed actual value (10V $\hat{=}$ 100% of the maximum speed) 12: Field current setpoint (10V = 100% of P76) 13: Torque setpoint (-8V ... +8V = -100% ... +100% of the theoretical motor torque at rated unit current and with the excitation current set with P76) 14: I²t monitoring (10V = F13 response level) 15: Speed setpoint directly at the speed controller input (-10V ... +10V = -100% ... +100% of the maximum speed) 16: Current setpoint, with sign (8V = 100% of the rated unit current) 17: Current actual value, with sign (8V = 100% of the rated unit current)
15		Reference potential 0 V
16		Unstabilized power supply P24 (+ 18 V to + 30 V)
17		<p>On/Stop command</p> <p>On H signal: Main contactor pulls-in via relay K2; Drive runs up to the operating speed along the ramp when controller enable signal simultaneously available at terminal 18</p> <p>Stop L signal: Speed ramps down to $n < n_{min}$ (P21), Controller inhibit, $i = 0$, main contactor (relay K2) drops out, after 10 s standstill excitation. The standstill excitation current can be set at parameter P96 (0% as supplied). The automatic standstill excitation can be switched-out with parameter P88 (P88 = 0)</p>
18		<p>Controller enable</p> <p>H signal: Enable, controllers are enabled</p> <p>L signal: No enable, controller inhibit ω_w shift, $i = 0$, inhibit firing pulses</p>

Terminal	Circuit diagram section 4.1-4.3	Function
19		<p>Digital input, function selectable via parameter 83 P83 = 0: No function (as supplied)</p> <p>1: Inch 1, inch setpoint at P11 (observe P14) H signal: Main contactor (relay K2) pulls-in, drive accelerates to inch setpoint via the ramp or speed controller (selectable via P14) L signal: Drive brakes, speed controlled to $n < n_{min}$ (P21), drive switches off after 10 s Inching is only possible with terminal 17 open circuit (STOP) and when terminal 18 is energized (controller enable). Refer to Section 8.6 for special crawl function.</p> <p>2: Inch 2, inch setpoint at P12, function as for inch 1</p> <p>3: No function</p> <p>4: Ramp-function generator enable H signal: Ramp-function generator is enabled L signal: Ramp-function generator inhibited (Ramp-function generator output $n = 0$)</p> <p>5: Hold ramp-function generator (interrupt ramp-up) H signal: Hold ramp-function generator L signal: Ramp-function generator ramps-up to the actual setpoint</p> <p>6: Off L signal: Controller inhibit, a_w shift, main contactor (relay K2) drops out after current is 0</p> <p>7: Fast stop L signal: Drive brakes to $n < n_{min}$ (P21) along the current limit, main contactor drops out after current is 0, signal is stored (storage is disabled by L signal at terminal 17)</p> <p>8: Current limit selection H signal: P41 and P42 effective, if $n > n_{select}$ (P50) L signal: P39 and P40 effective</p> <p>9: Changeover from speed to current control L signal: Drive operates speed controlled Setpoint terminals 4 and 6 (only when current control is not selected via P89) H signal: Drive operates current controlled Setpoint terminals 4 and 6, except when P85 = 11, then setpoint from terminal 8 (refer to description of terminal 8) The ramp-function generator is also effective in the current controlled mode. Zero current setpoint is input when terminal X1.17 is opened (also refer to Section 8.12.2)</p> <p>10: Reset fault memory H signal: An existing fault is acknowledged (corresponds to actuating the MODE key on the basic unit)</p>

Terminal	Circuit diagram section 4.1-4.3	Function
19		<p>11: Changeover master-slave drive (from SW 3.3 onwards) L signal: Drive operates as master drive (i.e. speed controlled). Setpoint terminal 4 and 6 (only when current control is not selected through P89) The ramp-function generator is effective.</p> <p>H signal: Drive operates as slave drive (i.e. current control) Setpoint terminal 4 and 6, except when P85 = 11, then the setpoint from terminal 8. The ramp-function generator is ineffective ($T_H = T_R = 0$) Zero current setpoint is only input when terminal X1.17 is opened and when $n < n_{min1}$ (P21) is reached (controlled braking by the master drive).</p> <p>12: Enable for changeover from P/P1 controller if $n_{act} < \text{parameter E41}$ (from software release 3.3 onwards) L signal: Changeover P/P1 controller function is effective H signal: Changeover P/P1 controller function is ineffective</p> <p>13: No function 14: No function</p>
20		<p>Digital input, function selectable via parameter 84 P84 = 0: up to Functions as for terminal 19 (P84 = 0 as supplied) 14:</p>
21		<p>Reference voltage For energizing terminals 17-20 from a floating source, i.e. reference potential from an external voltage source. Jumpers CE - CF inserted For energizing from the internal power supply</p> <p>- 24 V reference potential: Jumper CA - CB inserted 0 V reference potential: Jumper CC - CD inserted (as supplied)</p>
22		Ground connection, central M, 0 V
23		Power supply output, + 10 V, 10 mA, $\pm 0.5\%$
24		Reference voltage, 0 V
		Power supply output, - 10 V, 10 mA, $\pm 0.5\%$
		<p>} Connections for setpoint potent. e.g. 4.7kΩ</p>

The internal reference potential (BS) is fed to an M4 threaded connection on board A1. When supplied, the internal reference potential is connected to the heatsink potential (ground) through jumper BR2.

If jumper BR2 is opened, the reference potential is connected to the heatsink via $2 \times 0.1 \mu\text{F}$.

H signal: + 10 V to + 30 V (11 k Ω input resistance)
L signal: 0 V to + 5 V or open-circuit terminal

5. Start-up

5.0 General warning notes regarding start-up



DANGER



Before starting up the unit it must be ensured that the transparent cover over the power connections is installed in the correct location on the unit.



WARNING

This equipment contains hazardous voltages and hazardous rotating mechanical parts (fan). Loss of life, severe personal injury or property damage can result if instructions contained in this manual are not followed.

On the customer side, a hazardous voltage can be present at the signaling relays K1, K2 and K4...K7 (K4..K7 for supplementary board Z1210).

The units must not be connected to a supply with ground-fault circuit interrupter (VDE0160, Part 6.5), as, if a short-circuit or ground fault occurs, a DC component can be included in the fault current which hinders or even prevents the higher-level ground-fault circuit interrupter from tripping. In this case, all loads connected to this ground-fault circuit interrupter are not protected.

Only qualified personnel should work on this equipment, and only after becoming familiar with all safety notices, installation, operation and maintenance procedures contained in this manual.

Perfect and safe operation of this unit assumes correct transport and storage installation and mounting as well as careful operation and maintenance.

Even when the unit main contactor is open the unit still contains hazardous voltages.

The control board (lower board) contains many circuits at hazardous voltage levels. Before starting service or maintenance work, make sure that all incoming AC feeders are turned off and locked out.

These instructions do not represent an exhaustive survey of the steps necessary to ensure safe operation of the equipment. Should further information be desired or should particular problems arise which are not covered sufficiently for the purchaser's purposes, then the local Siemens office should be contacted.

The use of unauthorized components when repairing this unit or handling by non-qualified personnel will lead to dangerous conditions, which can result in loss of life, severe personal injury or property damage. All the safety measures listed in these operating instructions as well as the warning labels on the unit should be observed.

Observe all warning notes listed in Section 1 of these operating instructions.

5.1 Parametrizing device

The parametrizing device is used to carry out all necessary adaptations, settings and measurements for start-up. This consists of three keys and a three-digit 7-segment display:

- **Mode key:**
 - alternately selects the parameter number or value of that parameter
- **Raise key:**
 - to select a higher parameter number or
 - to increase a selected and displayed parameter value
- **Lower key:**
 - to select a lower parameter number or
 - to lower a selected and displayed parameter value

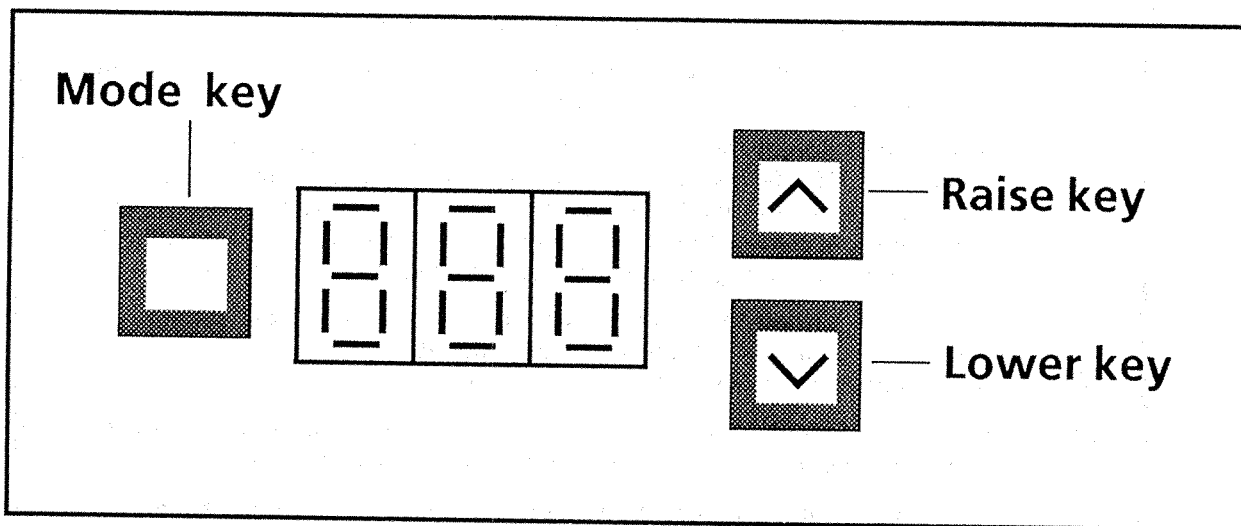

Parametrizing device

5.2 Parametrization procedure (example)

<div style="border: 1px solid black; padding: 5px; display: inline-block; text-align: center; width: 20px; height: 20px; margin-bottom: 5px;">1</div> <div style="border: 1px solid black; padding: 5px; display: inline-block; width: 300px; height: 30px; margin-top: 5px;">Switch-on unit</div>	<p>The operating status is displayed after switch-on: Contents of parameter P00</p>	
<div style="border: 1px solid black; padding: 5px; display: inline-block; text-align: center; width: 20px; height: 20px; margin-bottom: 5px;">2</div> <div style="border: 1px solid black; padding: 5px; display: inline-block; width: 300px; height: 30px; margin-top: 5px;">Press mode key to display the parameter number</div>	<p> The parameter number with P.. appears in the display: Parameter number for operating display</p>	
<div style="border: 1px solid black; padding: 5px; display: inline-block; text-align: center; width: 20px; height: 20px; margin-bottom: 5px;">3</div> <div style="border: 1px solid black; padding: 5px; display: inline-block; width: 300px; height: 30px; margin-top: 5px;">Select the required parameter number by depressing the raise or lower key</div>	<p> </p> <p>For example: Parameter number for the ramp-up time of the ramp-function generator</p>	
<div style="border: 1px solid black; padding: 5px; display: inline-block; text-align: center; width: 20px; height: 20px; margin-bottom: 5px;">4</div> <div style="border: 1px solid black; padding: 5px; display: inline-block; width: 300px; height: 30px; margin-top: 5px;">Display parameter value by depressing the mode key again</div>	<p></p> <p>For example: Ramp-up time 120 s, the unit is in the so-called value mode</p>	
<div style="border: 1px solid black; padding: 5px; display: inline-block; text-align: center; width: 20px; height: 20px; margin-bottom: 5px;">5</div> <div style="border: 1px solid black; padding: 5px; display: inline-block; width: 300px; height: 30px; margin-top: 5px;">Change parameter value with the raise or lower key</div>	<p> </p> <p>For example: New ramp-up time 180 s</p>	

NOTE

- Authorization to change the parameter must be entered before changing the parameter value with key parameter P51.
 - P51 = 4 Authorization to change parameters P1 to P79 and all E-, H- and U parameters
 - P51 = 10 Authorization to change parameters P80 to P89
 - P51 = 20 Authorization to change parameters P1 to P9 and all E-, H- and U parameters
 - P51 = 99 Service setting, authorization to change L parameters. Refer to the parameter list (Section9) before setting P51 parameters!
- P51 is automatically set to "0" after the supply voltage is switched-off.
- If the unit indicates the parameter value and no key is actuated, the associated parameter number is displayed for approx. 6 sec. in a 1 sec. clock (not for display parameters).
- Changed parameter contents are automatically stored and are retained even after the supply voltage has been switched-off, if plug-in jumper EA - EB - EC on board A1200 is set to position EB - EC (up to version 03, C1, ... on board A1200: Jumper Br5 inserted), and parameter P87 = 0x (exception: Key parameter P51). Automatic parameter storage in the non-volatile parameter memory (EEPROM) can be prevented by the jumper EA - EB - EC (or jumper Br5) and the parameter P87 = 1x oder 2x. Setting P87 = 3x is recommended when terminal 17 is often energized!

5.3 Potentiometers

Four potentiometers are located on each unit in addition to the parametrization unit.

Designation	Value	Function
R1: n_{act} - coarse		Coarse adaption of the speed actual value; Clockwise rotation → higher speed
R2: n_{act} - fine		Fine adaption of the speed actual value; Clockwise rotation → higher speed
R3: n_{act} - display	$\pm 10 \text{ V}, 2 \text{ mA}$	Adaption for speed indication (terminal 10) Setting range $(0.6 - 1.6) \times 10 \text{ V} \triangleq n_{max}$
R4: I_{act} - display	$\pm 10 \text{ V}, 2 \text{ mA}$	Adaption for current indication (terminal 12) Setting range $(0.5 - 1.1) \times 10 \text{ V} \triangleq I_{Nunit}$

5.4 Initial program loading

The parameters are preset when the unit is supplied, so that generally speaking a drive can be started up without further parameter setting (not optimized). Only the speed actual value adjustment must be made.

The initial program loading values of the parameters (default values) can be taken from the parameter list, Section 9.

The unit can be reset by initial program loading to the status as supplied from the factory: (The following sequence must be observed!)

- Switch-on electronics power supply 2U, 2W (380 V)
- Set P51 = 20
- Set the following parameters manually to the required values (refer to Section 9, parameter list)
 - Parameter P98: Power section supply voltage
 - Parameter P99: Unit version and software release
 - Parameter E00: Available options
- Select P52
- Select value-mode
- Depress raise or lower key
- Switch-off electronics power supply 2U, 2W for at least 2 s and switch-on again
- Message with operating status display
- Keep the electronics power supply 2U, 2W switched-on for at least 15 s!
(only after this, are the initial program loading values actually stored in the permanent memory)

Key parameter P51 has the value "0" again after initial program loading. No parameter changes are possible in this condition.

The following preset parameters are not changed by initial program loading: P98, P99, E00

NOTE

The initial program loading function can only be executed, if no hardware write protection is available.

For this: Up to version 03 or C1, ... of board A1200, insert jumper BR5
From version 04 or D1, ... of board A1200, set EA - EB - EC plug-in jumper to the EB - EC position

Parameter P87 is set to the default value during initial program loading. Also refer to Section 5.9.

5.5 Start-up procedure

WARNING

This unit contains hazardous voltages.

Even when the equipment main contactor is open, the equipment still has hazardous voltage levels.

The control board (lower board) has several circuits at hazardous voltage levels.

Loss of life, serious bodily injury or material damage can result if the instructions contained in these operating instructions are not followed.

- 1 Unit must be in the no-voltage condition (power disconnected)!
Check the connections according to the installation circuit diagram or the recommended connecting diagram.
Remove the ribbon cable connection or plug-in terminals when using supplementary boards (basic start-up without supplementary boards, exception: Z1004 technology board)
- 2 Open terminal 17 (On/Stop) and terminal 18 (enable)
- 3 For versions up to 03 or C1, . . . , close jumper BR 5 on board A1200
For versions 04 or D1, . . . onwards, set the plug-in jumper EA - EB - EC in the EB - EC setting on board A1200. (as supplied)
Check the plug-in jumper FA-FB-FC on board A1200 from version 04 or D1, . . . onwards.
Software version:
≤ 2.2 (128k EPROM) insert jumper FA-FB
≥ 3.0 (256k EPROM) insert jumper FB-FC
(boards A1200 up to version 03 or C1, . . . do not have this jumper, and therefore cannot be upgraded to software release 2.2)
- 4 Open armature circuit (fuse)
- 5 Remove field connection 3D
- 6 Switch main switch "On"
- 7 Switch electr. power supply "On"

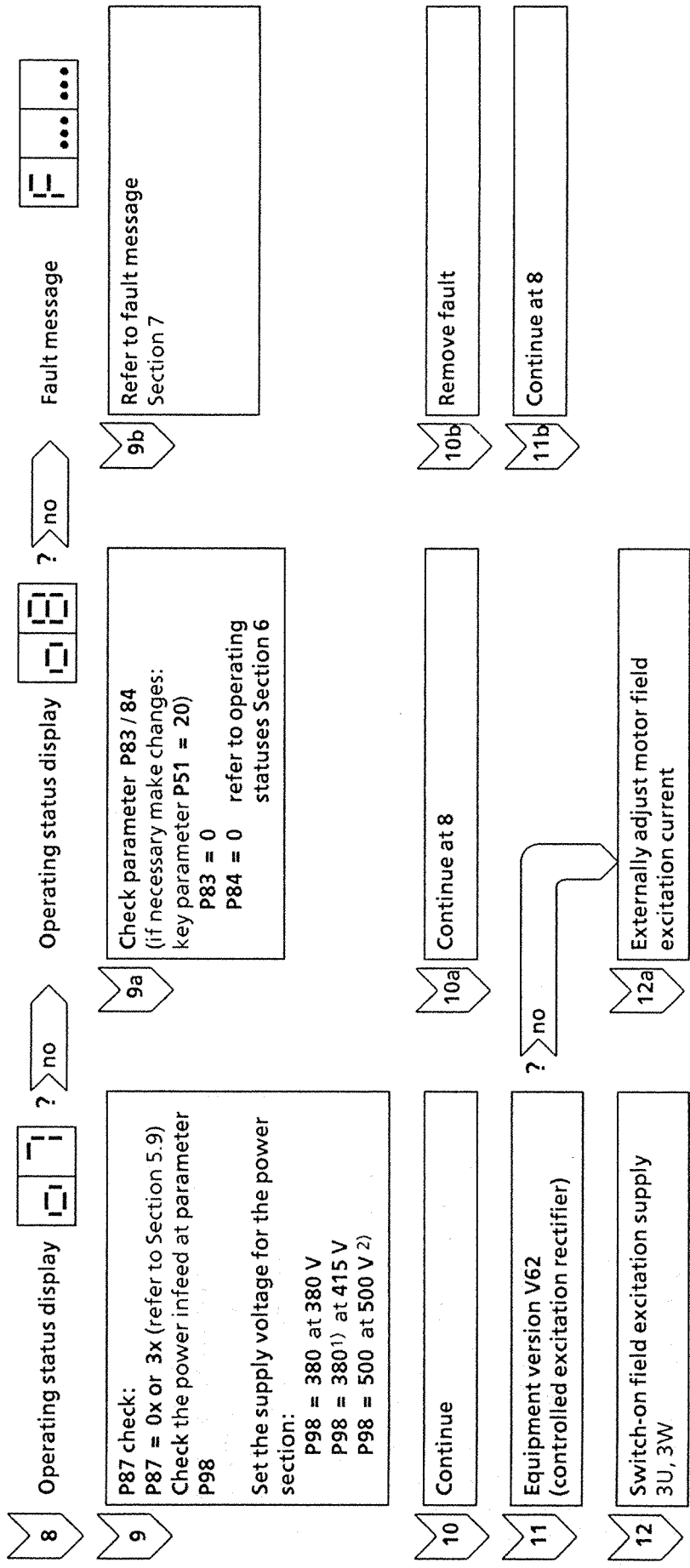

1) Is valid, if the electronics power supply is connected to the 415 V supply without transformer

$$2) \frac{V_{\text{electronics power supply}} \cdot V_{N \text{ power section}}}{380} = P98 \quad [V]$$

e.g. $380 \cdot \frac{500}{380} = 500$: (when using Volt transformer for electronics power supply)

13 Check that the electronics power supply 2U, 3U has the same phase sequence as the field excitation supply 2W 3W using a volt meter:
Voltage = 0 V at 380 V field supply
Voltage = 160 V at 220 V field supply

14 Switch main switch "Off"

15 Connect the field connection 3D

16 Switch main switch "On"

17 Key parameter P51 = 20

18 Set the ratio between the motor excitation current (refer to motor rating plate) and the converter excitation current (converter rating plate) in % using parameter P76. Adapt burden resistor if the motor excitation current < 30% converter excitation current (refer to burden resistor table, Section 4.4).

19 **Checking the excitation current:**
Close terminal 17 (no standstill excitation), check field current with ammeter and correct with P76;
Open terminal 17

13a Key parameter P51 = 20
Set P76 = 1

14a Continue at 20



! WARNING

This unit contains hazardous voltages.

Even when the equipment main contactor is open, the equipment still has hazardous voltage levels.

The control board (lower board) has several circuits at hazardous voltage levels.

Loss of life, serious bodily injury or material damage can result if the instructions contained in these operating instructions are not followed.

20

Set the ratio of motor current to converter rated current in % using parameter P71, (if motor rated current $\leq 30\%$ of the converter rated current adapt burden load resistors, refer to burden resistor table, Section 4.4)

21

Check or adjust the current limiting
P39 % of motor rated current,
torque direction 1
P40 % of motor rated current,
torque direction 2
(only for 4Q operation)
Set to required motor current, e.g.
100%.

22

Switch main switch off

23

Insert armature fuse

24

Switch main switch on and power on,
i.e. H signal at terminal 17, controller
enable, terminal 18 remains open-
circuit

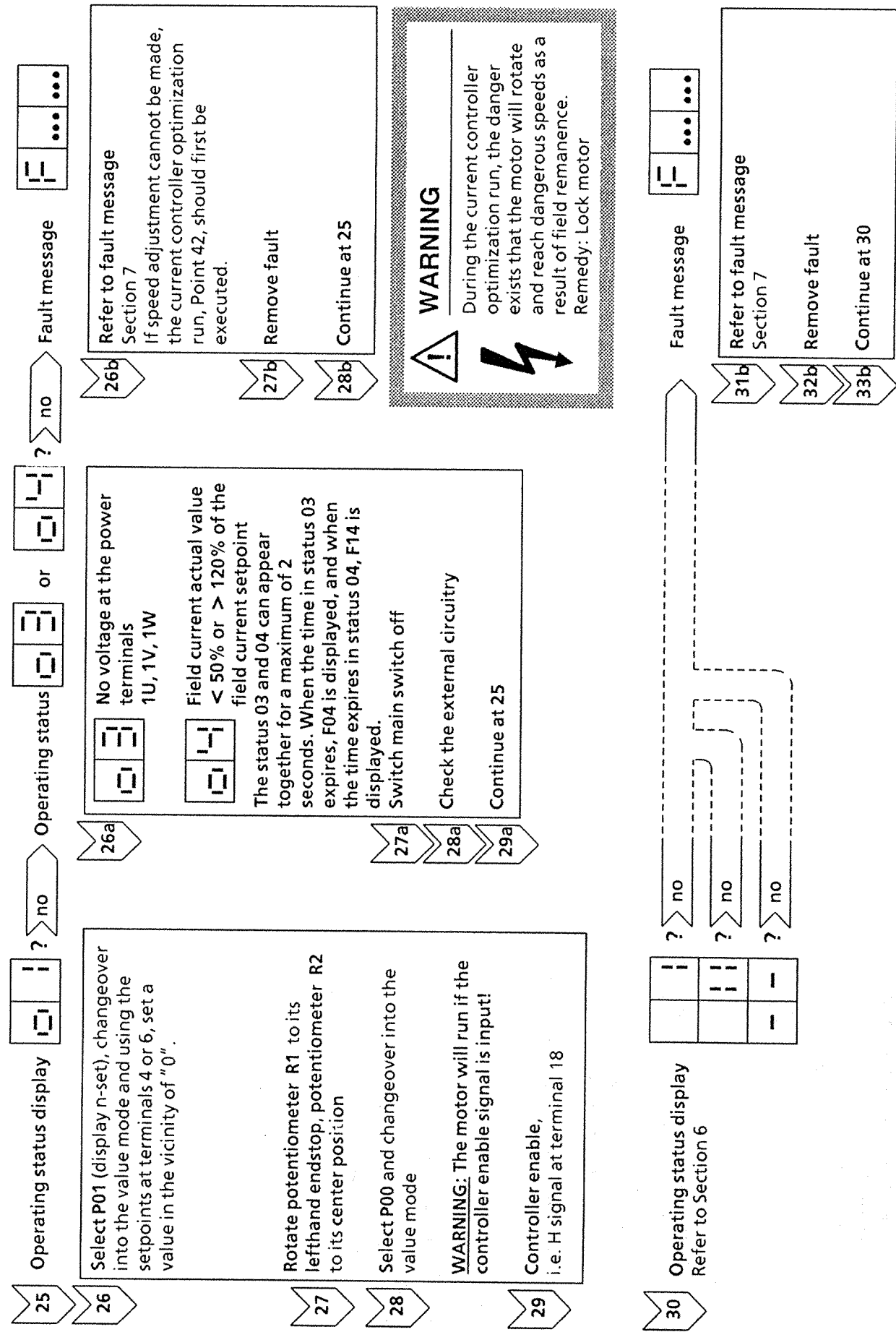

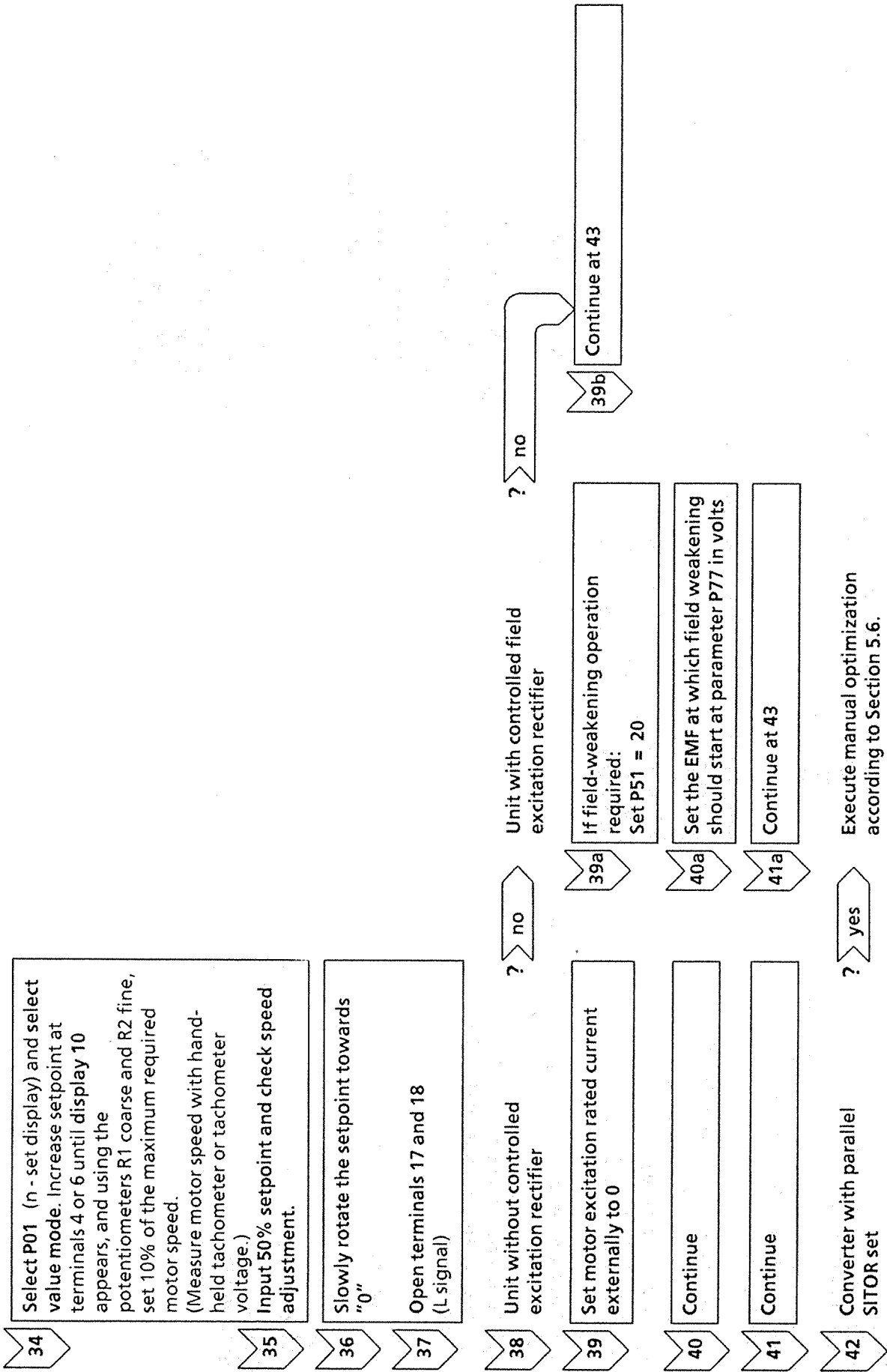

5.5.1 Current control optimization

1) The following parameters are automatically set:

P66: $i \times R$ compensation in the discontinuous d.c. operation

P67: $i \times R$ compensation in continuous flow

P68: Transition from continuous to discontinuous current in % of the unit rated current

P64: K_P , gain

P65: T_i , integral-action time in ms

NOTE

The optimization run is not executed when the lower key is depressed, P51 is automatically set to 0.

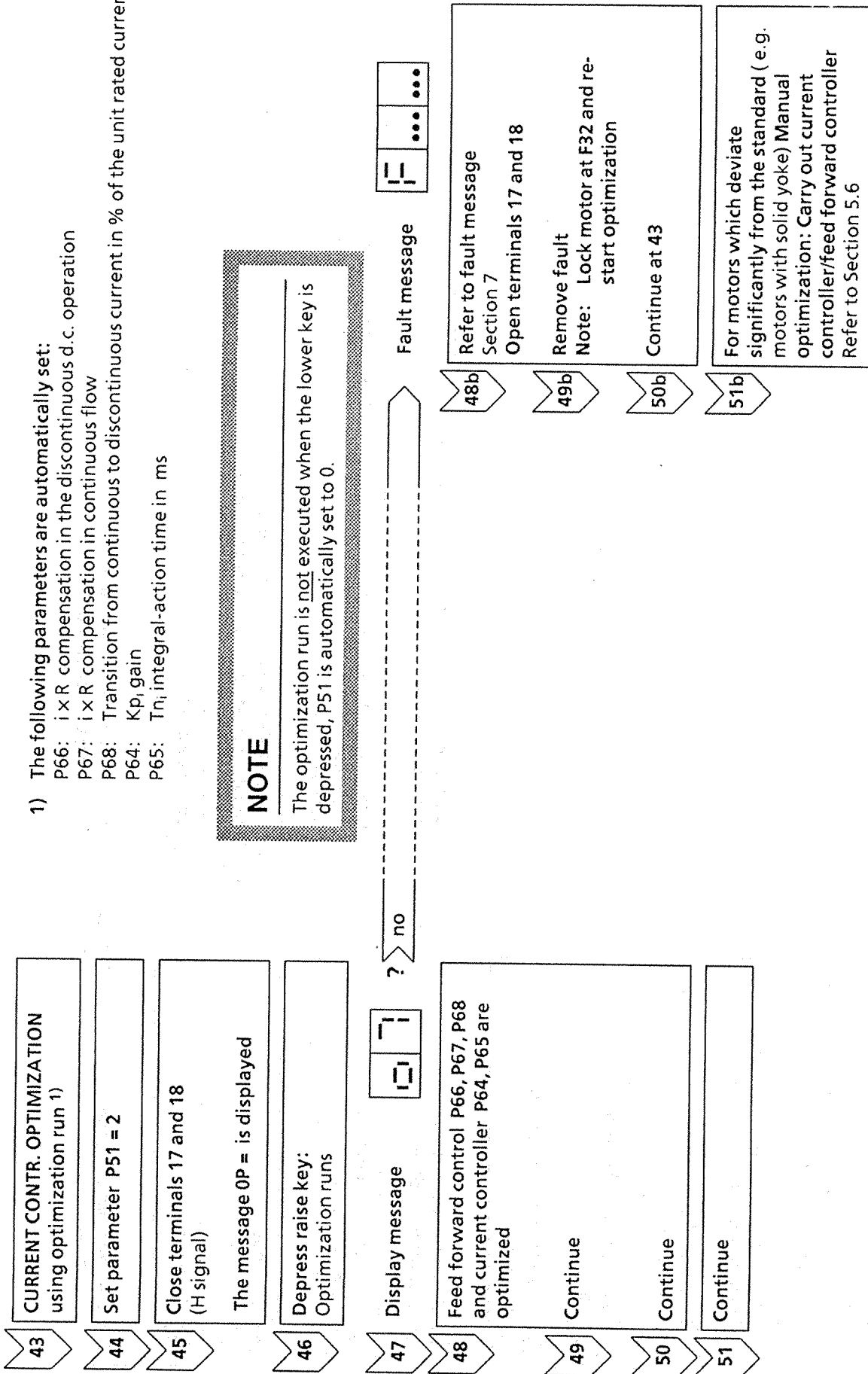

5.5.2 Speed control optimization

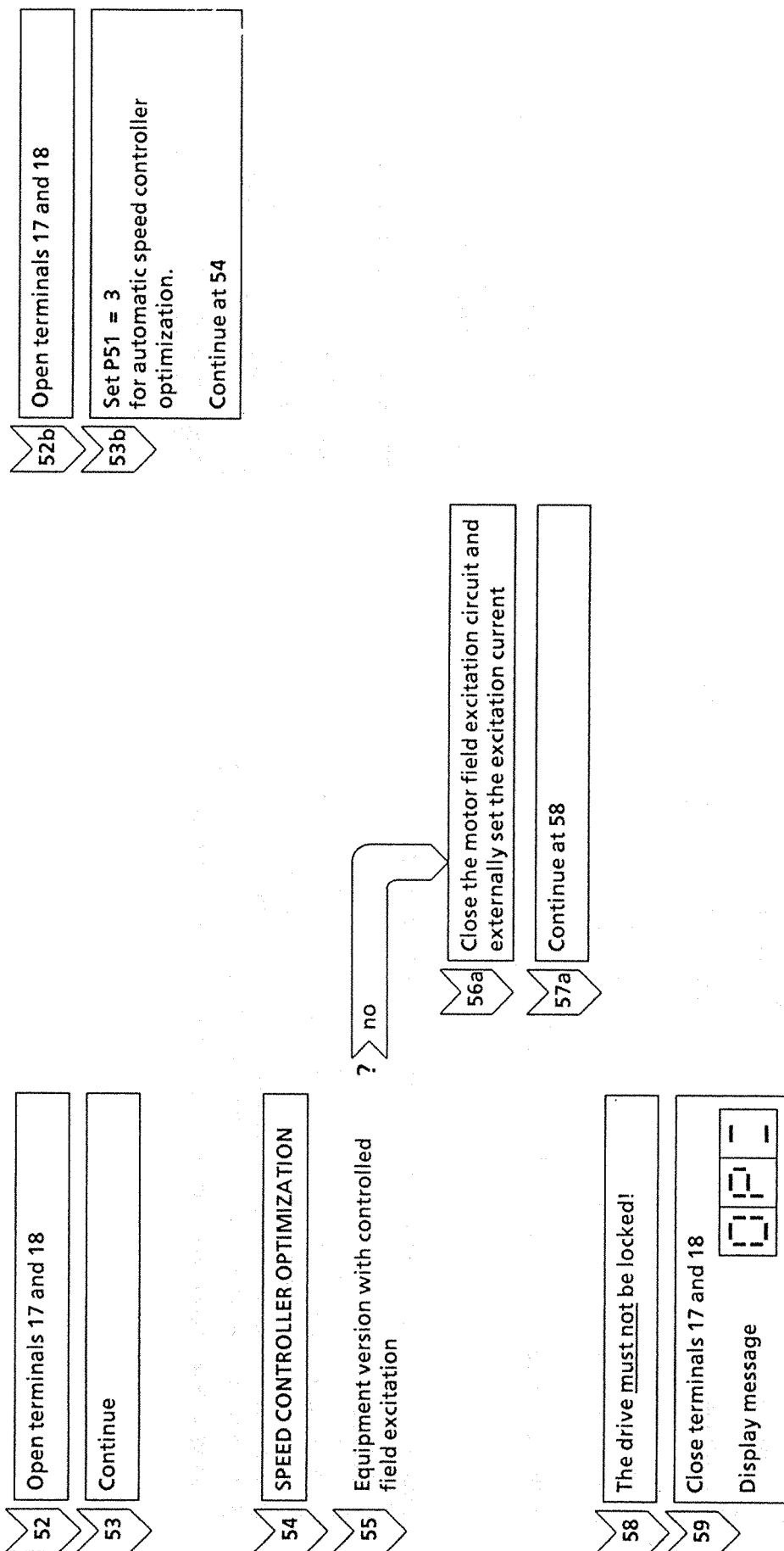

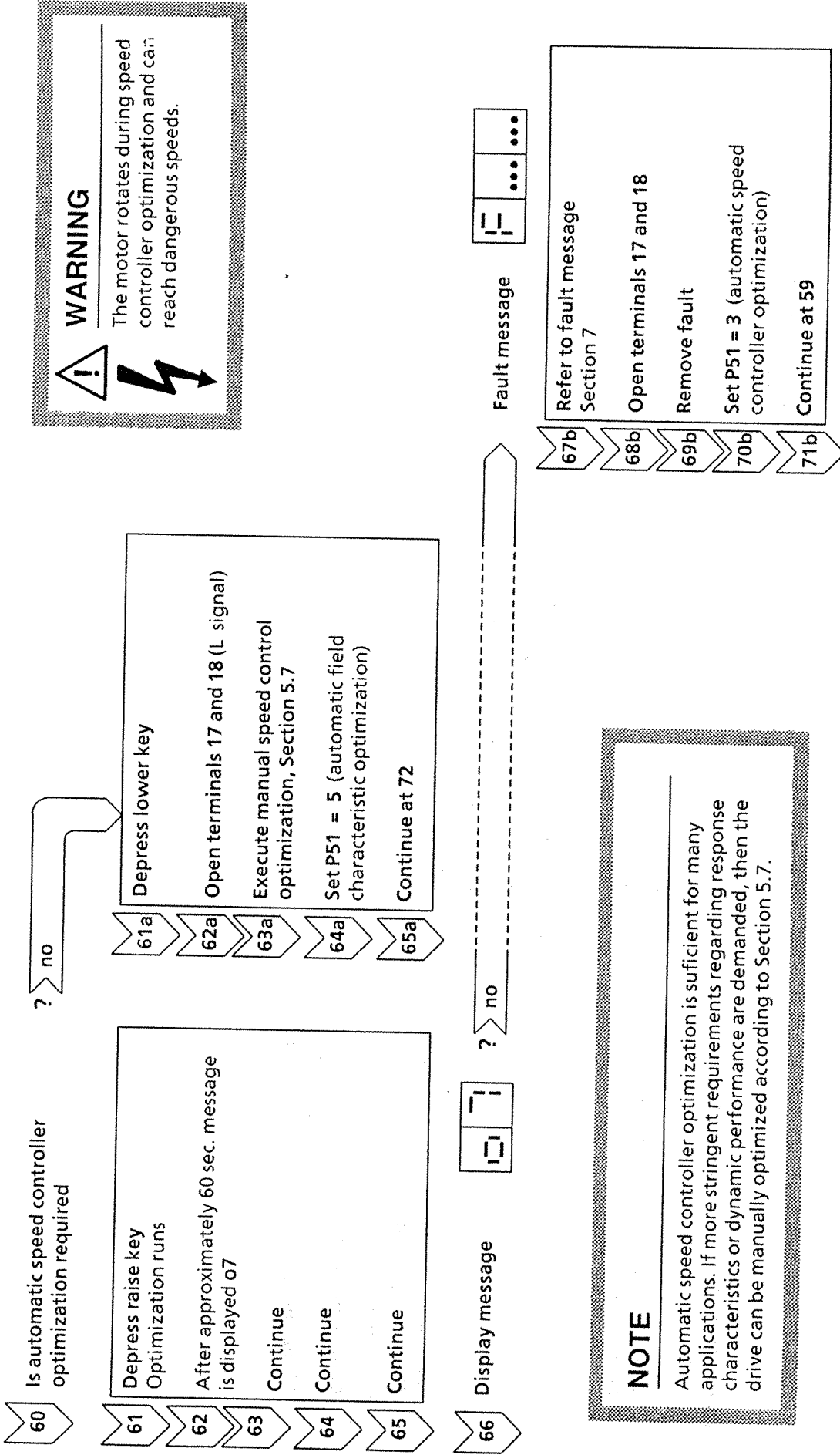

WARNING

The motor rotates during speed controller optimization and can reach dangerous speeds.



Display message

? no



Fault message

NOTE

Automatic speed controller optimization is sufficient for many applications. If more stringent requirements regarding response characteristics or dynamic performance are demanded, then the drive can be manually optimized according to Section 5.7.

Refer to fault message Section 7

Open terminals 17 and 18

Remove fault

Set P51 = 3 (automatic speed controller optimization)

Continue at 59

67b

68b

69b

70b

71b

5.5.3 Field characteristic test

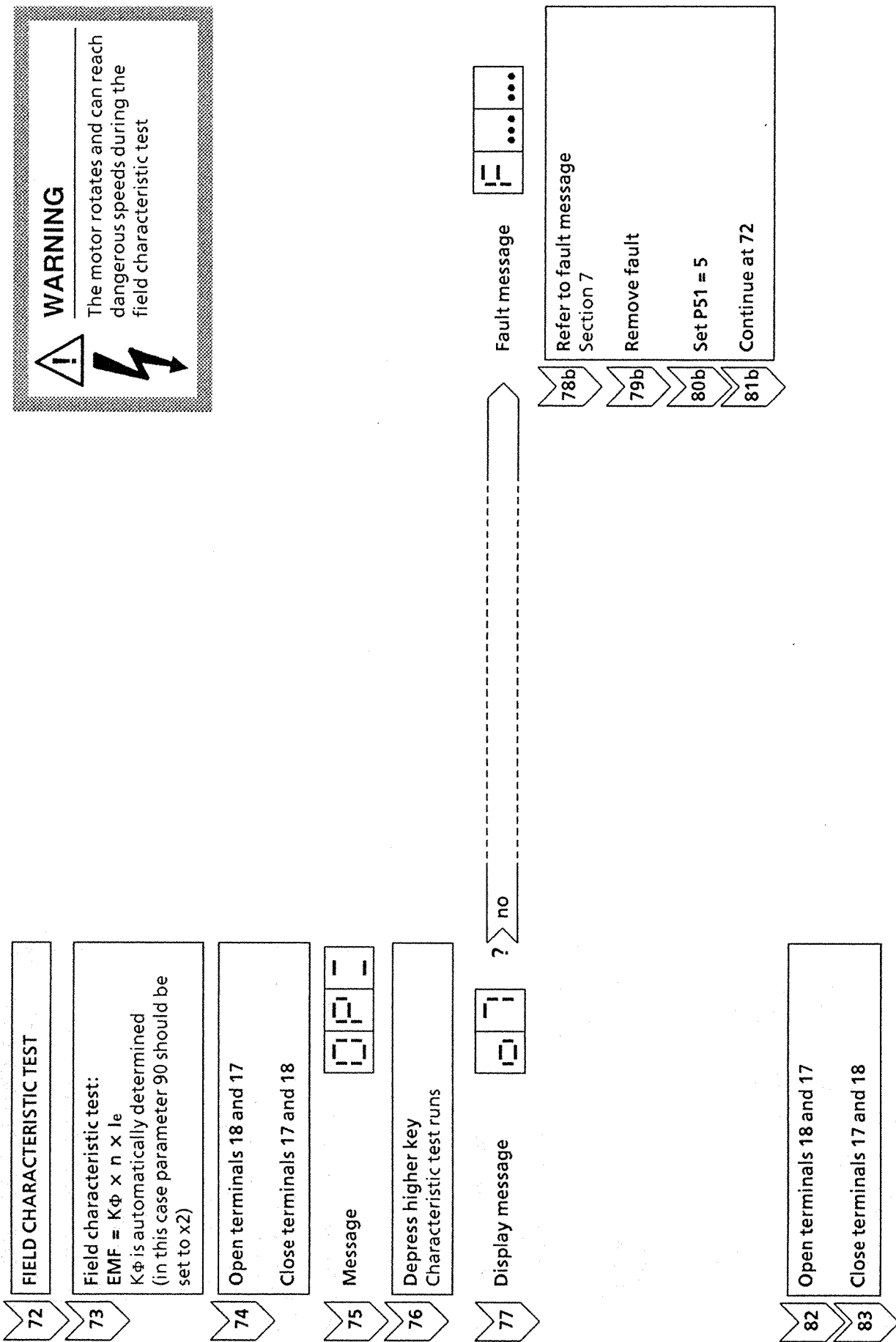

5.5.4 EMF controller optimization

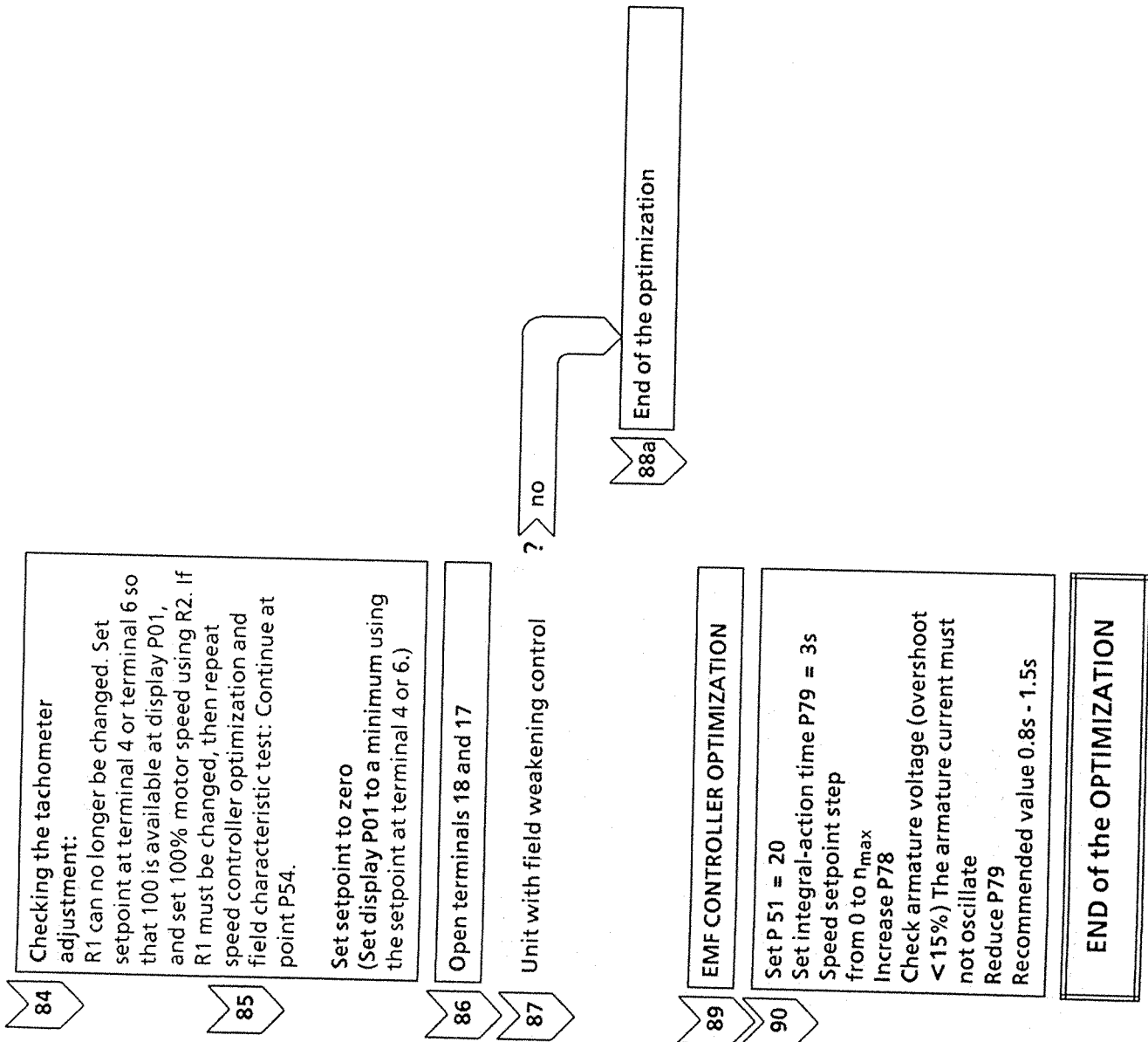

5.6 Manual optimization of the feed-forward current control

Prerequisite: Key parameter P51 = 4

5.6.1 Setting the feed-forward control

- 1** P76 = 0: Field current setpoint = 0
P82 = 7: Terminal 14 = Current controller integrator
P89 = 3: Drive operates current controlled
P69 = 1: Switch-out EMF feed for con.
- 2** Connect 10 V measuring instrument (e.g. Multizet) between terminals 14 and 15 (= reference voltage)
- 3** Connect terminals 17 and 18.
Warning: drive is current controlled and can overspeed by accelerating with the motor residual field (lock motor if necessary)
- 4** Input a current setpoint of 80% (can be measured at P01), adjust P67 until the measuring instrument indicates a minimum, set P66 the same as P67 and repeat point 4
- 5** Input a current setpoint of 10% (can be measured at P01)
Adjust P68 until the measuring instrument indicates a minimum.
P68: Transition from discontinuous to continuous current
A check can be made by calculation.
Calculating the transition from discontinuous to continuous current:
The transition from discontinuous to continuous current is set in parameter P68.

$$P68 = \frac{U_{rms}}{I_{rated}} \times \frac{40}{L_{armature}}$$

U_{rms} = rms value of the supply voltage in V
 I_N = Unit rated current in A
 L = Armature circuit inductance in mH
Set P69 = 0, repeat point 5
- 6** P89 = 0: Speed controlled
P76 = set required field current

5.6.2 Current controller setting

- 1 Parameter P64 :Proportional gain of the current controller
 - 2 Parameter P65 : Current controller integral action time in ms
- Recommended values:**
P64 = 0.2 to 0.5
P65 = 15 to 50ms, but should approximately correspond to the armature time constant L/R

5.7 Speed controller manual optimization

Prerequisite: Key parameter P51 = 4

- 1 Parameter P31 : Proportional gain of the speed controller
- 2 Parameter P32 : Speed controller integral action time in s

Values gained from experience:
P32 = 4 x P65
e.g. P65 = 25ms
25 x 4 = 100ms →
Set P32 = 0.1s
Set P31 to approx. 5 to 20
(Increase P31 until the drive starts to oscillate, then reduce the value of P31 by half)

5.8 Field characteristic for field weakening operation

If the units are operated with automatic field weakening, a field characteristic must be stored (L parameters). The characteristic can be tested using the automatic optimization.

Prerequisite: Field weakening response point P77 set and speed actual value adjustment executed.

P77 The EMF in volts should be entered here, where field weakening starts.

As supplied from the factory = 0, no field weakening

$$P77 = V_{AN} - R_A \times I_{AN}$$

whereby V_{AN} : Rated armature voltage (rating plate)
 I_{AN} : Rated armature current
 R_A : Armature circuit resistance (warm, at 20°C ambient temperature)

0 V must be entered when operation is only in the armature control range. If EMF_{set} is not known, then alternatively, the motor armature voltage can be entered into parameter E77 (prerequisite P90 = x1x). The EMF setpoint is then automatically calculated during the field characteristic test and written into P77.

Refer to parameter list, P51 = 5 for the automatic field characteristic test.

Field characteristic

Using the L parameters, the characteristic parameters determined during the field characteristic test can be read out and can thus be directly manually entered into the L parameters, bypassing the automatic field characteristic test (e.g. EPROM replacement)

NOTE

As many identical motors have magnetization characteristics which deviate from each other, it is recommended, when starting up several identical motors, to execute the automatic field characteristic test for each individual drive.

Manual input of the field characteristic should only be executed in exceptional cases, when no automatic field characteristic test is possible

The follow L parameters must be written into if an automatic field characteristic test is not executed. Set key parameters P51 = 9 in order to set the L parameters.

- L08 = 1: "Field characteristic test executed" flag
- L08 = 0: Field characteristic test not error free
- L09 : EMF setpoint [in volt] at the response speed (start of field weakening). ¹⁾
- L10 : Response speed [in % of n_{max}]
- L11 : 1st characteristic point [in % of n_{max}]
- L12 : 2nd characteristic point [in % of n_{max}]
- L13 : 3rd characteristic point [in % of n_{max}]
- L14 : 4th characteristic point [in % of n_{max}]
- L15 : 5th characteristic point [in % of n_{max}]
- L16 : 6th characteristic point [in % of n_{max}]
- L17 : 7th characteristic point [in % of n_{max}]
- L18 : 8th characteristic point [in % of n_{max}]
- L19 : 9th characteristic point [in % of n_{max}]
- L20 : 10th characteristic point [in % of n_{max}]
- L21 : 11th characteristic point [in % of n_{max}]
- L22 : 12th characteristic point [in % of n_{max}]
- L23 : 13th characteristic point [in % of n_{max}]
- L24 : 14th characteristic point [in % of n_{max}]
- L25 : 15th characteristic point [in % of n_{max}]
- L26 : 16th characteristic point [in % of n_{max}]
- L27 : 17th characteristic point [in % of n_{max}]
- L28 : 18th characteristic point [in % of n_{max}]
- L29 : 19th characteristic point [in % of n_{max}]
- L30 : 20th characteristic point [in % of n_{max}]
- L31 : 2x number of valid characteristic points
- L32 : Minimum field current at n_{max} [255 = rated field current (P76)]
- P77 = EMF setpoint [in volt] at the response speed (= parameter L09)
- Set P90 = 00!

If the motor is only to be operated in the armature control range (constant field current), then the automatic field characteristic test must also be executed, or the following settings made.

- L08 = 1
- L09 = EMK [in volt] at n_{max}
- L10 = 100%
- P77 = 0
- L31 = 0
- L32 = 255

and finally set

P90 = 00



WARNING

In the setting P51 = 99, all parameters can be changed during operation (ON-LINE). This can cause the drive to respond in a hazardous fashion.



Thus, the following procedure is recommended:

Before setting parameter P51 to 99, remove terminal blocks X1.16 to 22 (controller enable X1.18 and "ON/STOP" X.17 are not energized), thus the unit cannot be operated online.

Set parameter P51 to 0 after setting the L parameters and before inserting the plug-in terminals.

Example of a field characteristic

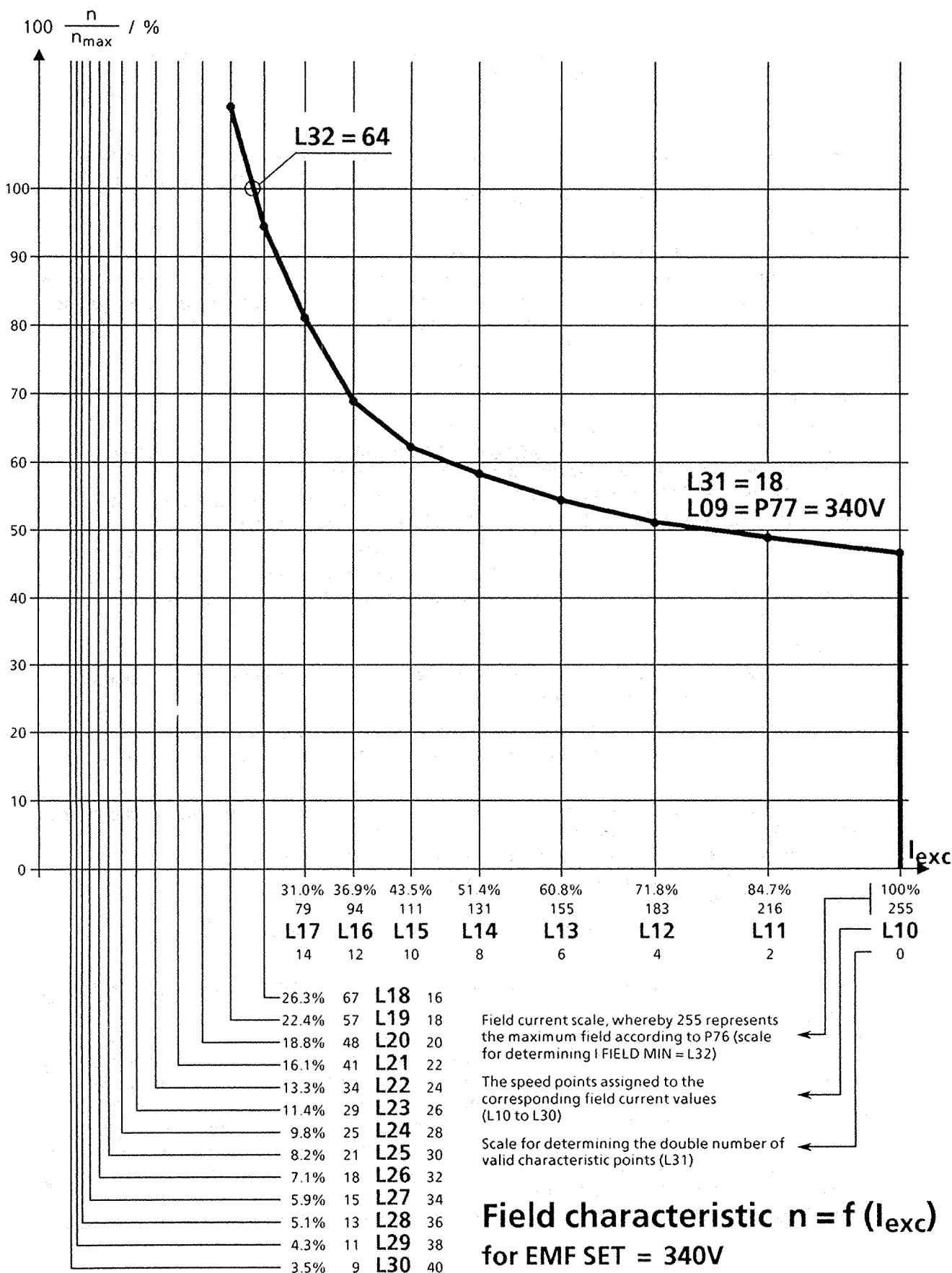

5.9 Storing the parameters in a non-volatile memory

Setting during start-up: Up to version 03 or C1, ... of board A1200, insert jumper BR5.
From version 04 or D1, ... of board A1200, plug-in jumper
EA - EB - EC is set to EB - EC.
Set P87 to 0x or 3x!

P87 = 0x

Every parameter change and fault message is immediately transferred into the non-volatile memory. The parameter memory -RAM monitoring is effective. Setting 3x is recommended when terminal 17 is often energized (ON/STOP).

P87 = 1x

Protection against subsequent parameter change.

Only parameters P87 and P52 are transferred immediately into the non-volatile memory at each change, the remaining parameters are not stored in the EEPROM. After the supply voltage has been switched-off, the parameters originally stored in the EEPROM are used. Automatic fault acknowledgement at power failure!

The F34 fault message ("EEPROM fault") is ineffective!

P87 = 2x

Protection against subsequent parameter change.

Parameters P87 and P52 and fault messages are immediately transferred into the non-volatile memory at each change, the remaining parameters are not stored in the EEPROM.

The fault message F34 ("EEPROM fault") is ineffective! Setting 2x is recommended when the parameters are frequently changed through a digital supplementary board.

The parameter contents can be changed with active EEPROM inhibit (P87 = 1x or 2x), and with the electronics power supply switched-on. The changes are also immediately effective. The changed parameter contents however are only stored in the RAM and are lost when the electronics power supply is switched-off.

P87 = 3x

Every parameter change and fault message is immediately transferred into the non-volatile memory. The parameter memory-RAM monitoring is effective.

F04 and F05 cannot always be stored when the electronics power supply fails, and thus the motor can rotate again when the supply voltage returns and the enable signals are present.

An additional hardware write protection can be activated with activated permanent memory inhibit (P87 = 1x or 2x) (no changes are stored in the EEPROM).

For this purpose, the following is realized on the A1200 electronics board
up to version 03 or C1, ...: jumper BR 5 is removed

from version 04 or D1, ...: plug-in jumper EA - EB - EC is set to EA - EB.

The jumpers must only be changed when the unit is de-energized (power off).

NOTE

The parameter changes made during start-up, or the parameter values found during the optimization runs (also field characteristic: parameters L08 to L32 can be read-out via key parameter P51, setting 99) should be documented after start-up on the "start-up list" sheet. The parameter values can be printed out when using the Z1210 supplementary board and a printer (automatic parameter documentation). More detailed information is provided in the operating instructions for the Z1210 supplementary board (Order No.: C98043-A1210-L31-*-19).

6. Operating conditions (display appears after switch-on or at parameter P00)

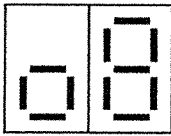
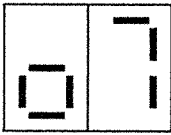
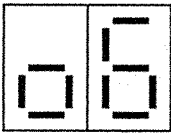
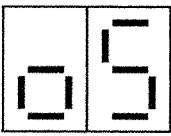
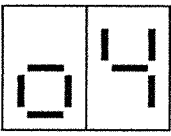
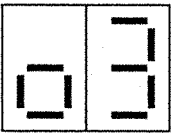
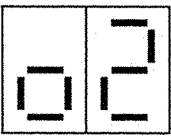
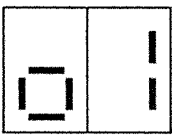
Display	Meaning
	1) Only displayed when terminal 19 or 20 is selected as fast stop (P83 or P84 = 7). Fast stop is input (terminal 19 or 20 open-circuit or <4.5 V). When fast stop is cancelled (applying 17 to 30 V at terminal 19 or 20) and then opening and closing terminal 17 (ON/STOP), the wait condition is left, and a jump made to the next operating display.
	Stop signal is input (terminal 17 open-circuit or <4.5 V). The wait condition is exited, and a jump made to the next operating display by providing an On signal (17-30 V at terminal 17).
	2) Is displayed when terminal 19 or 20 is selected as Off (P83 or P84 = 6). Off signal is input (terminal 19 or 20 open-circuit or <4.5 V). The wait condition is left, and another operating display is selected when the Off signal is cancelled (applying 17-30 V at terminal 19 or 20).
	Not used
	3) The field current actual value is <50% of the set field current setpoint P76. The next operating display is selected if P76 = 0, or the field current actual value is in the vicinity of the field current setpoint.
	3) No voltage available at the power connections (measured using optocoupler). The next operating display is selected after voltage has been measured at the power connections (power contactor switched-in).
	Checking the supply voltage characteristics [or checking the thyristors (refer to parameter E39)] The next operating display is automatically selected when the supply voltage is OK (and the thyristors are OK).
	No enable signal at terminal 18 (open-circuit or <4.5 V) The wait condition is left, and one of the following operating displays is selected by providing an enable signal (17-30 V at terminal 18).

- 1) The FAST STOP function is also effective in current-controlled operation (P89 = 3)!
If FAST STOP is input in current-controlled operation, the speed controller is automatically switched-in, and the FAST STOP function is realized via the speed controller.
WARNING: The speed controller parameters, must in this case, be set approximately correct!
WARNING: The FAST STOP function is not effective in the settings P89 = 2 or P63 = 3!
- 2) Can occur if "OFF" is issued internally, e.g. acknowledgement of a fault message when the motor is still rotating (refer to Section 7.1). The drive can be switched-on again after opening terminal 17 and energizing terminal 17 again (e.g. input "ON").
- 3) Conditions 03 and 04 can together, only be present for a maximum of 2 seconds. F04 is displayed if the time expires in condition 03, and if the time expires in condition 04, F14 is displayed.

Display	Meaning
---------	---------



4) No torque direction requested

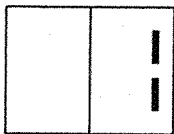

Torque direction I in operation:
Positive output current from 1C(D) to 1D(C)

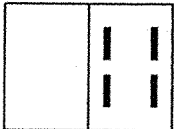

Torque direction II in operation:
Negative output current from 1C(D) to 1D(C)

- 4) If the motor still does not rotate in spite of an available setpoint and displays the value -- at parameter P00, parameter P01 (setpoint), P83, P84 and P85 (selector terminals) and P39 to P41 (current limits) should be checked. If a selector terminal is parametrized as ramp-function generator enable function, then it must be energized.

The hundred's digit of parameter P00 (operating status display) indicates whether the speed setpoint or current setpoint are at a limit.

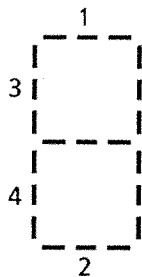

Segment 1 lit,

if the speed controller setpoint is at the positive limit (attempts to generate T I)

Segment 2 lit,

if the speed controller setpoint is at the negative limit (attempts to generate T II)

Segment 3 lit,

if the current controller setpoint is at the positive limit (attempts to generate T I)

Segment 4 lit,

if the current controller setpoint is at the negative limit (attempts to generate T II)

7. Fault messages

A fault display automatically appears when a fault occurs in the I, II or – – operating conditions. The display consists of a F at the first digit followed by a 2-digit number. The fault display flashes.

7.1 Fault message acknowledgement

Renewed switch-on with acknowledgement

If a fault is displayed, it must be acknowledged by depressing the mode key on the unit. When the fault has been removed and acknowledged, a stop command must be given prior to renewed switch-on (terminal 17 open circuit or $<4.5\text{ V}$) and $n < n_{\min}$ (P21).

NOTE

For software release 3.2 onwards, the fault can be acknowledged via selector terminal X1.19 or X1.20.

Caution: Do not input a continuous acknowledge signal!

Renewed switch-on without acknowledgement

When x2 or x3 is set at parameter P87, the unit can be switched-on again by energizing the on/off terminal (open-circuit or $\leq 4.5\text{ V}$) for the following faults. (acknowledgement at the unit is not necessary):

F04 : Phase failure, line-side fuse

F05 : Supply voltage out of tolerance ($\pm 20\%$)

F12 : $i > 300\%$: Current actual value $> 300\%$ of the rated unit current

F13 : i^2t monitoring responded

F14: Minimum field current not reached

F21 : External pulse cancellation input

(gating board Units 30A to 600A, terminal 7 not connected to terminal 8

Units 640A to 1200A, terminal 16 not connected to terminal 17)

The fault display is retained, but it no longer flashes. It can be acknowledged at the unit.

Automatic renewed switch-on at phase failure:

When parameter P87 is set to x1 or x3, automatic restart is realized after phase failure when the phase returns within approx. 400ms.

The signaling relay K1 can however briefly drop-out.

7.2 Fault list

7.2.1 Supply faults

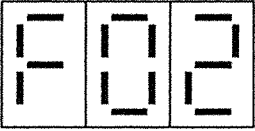
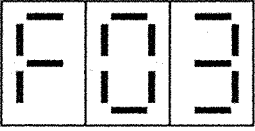
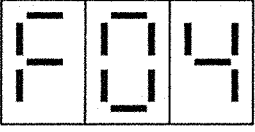
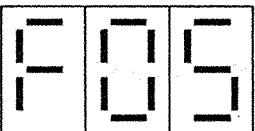
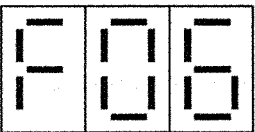
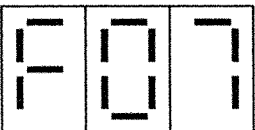
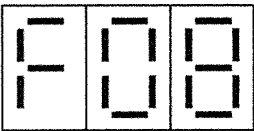
Display	Significance
	Incorrect phase sequence for synchronizing voltage does not coincide with the phase voltage at the power section.
	Supply frequency not in the range from 45 Hz to 65 Hz or frequency change > 1.5Hz/sec also refer to Section 8.13 (operation on weak supply network)
	Phase failure, line-side fuse: Also occurs when the supply voltage is withdrawn with terminal 17 energized. The power section can only be isolated from the supply voltage after relay K2 has dropped out.
	Supply voltage out of tolerance ($\pm 20\%$).
	Parity error at data receive via the serial interface through supplementary board Z1210 (e.g. P97 incorrectly set, data format of the PG635 / PG675 / PG685 incorrectly set)
	Syntax error at data receive via the serial interface through supplementary board Z1210 (for more detailed information, refer to operating instructions "Input/output expansion Z1210")
	Is only used for the spindle positioning option (main spindle drive 6RA27..). (possible cause: Parameter E00 incorrectly set)

NOTE

The alarm and fault messages integrated into the SIMOREG unit regarding overspeed and tachometer errors are derived from a common speed actual value and therefore do not represent a redundant safety system. The relevant regulations should be implemented when fulfilling personnel safety and protection requirements.

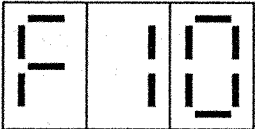
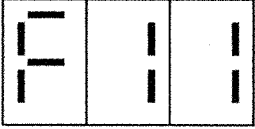
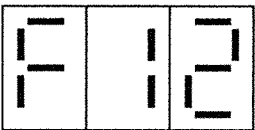
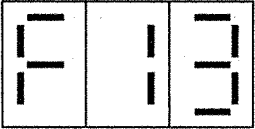
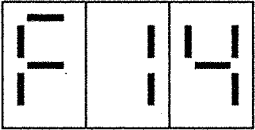
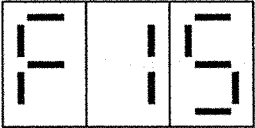
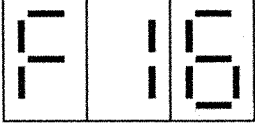
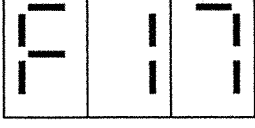
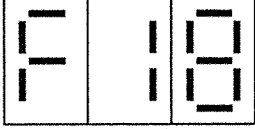
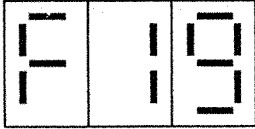

7.2.2 Motor-related faults

Display	Significance
	<p>Overspeed message (responds when the speed, set at parameter E21, is exceeded). The fault message is switched-out for setting E21 = 0.</p>
	<p>Tachometer fault (interrupted tachometer cable, overload on the tachometer or incorrect tachometer polarity), speed actual value ripple too high; also refer to Section 8.1.3 (operation on weak supply network)</p>
	<p>i > 300% Current actual value > 300% of the rated unit current Possible causes: 2U-2W power supply incorrectly connected (incorrect feed forward control)(execute instructions given in Section 5.6) Defective power semiconductors (check the currents with an oscilloscope connected to terminal X1:12) Current ripple too high (low inductivity in the armature circuit)</p>
	<p>i² t monitoring has responded (motor too hot) The fault message is masked out for setting P70 = 0. Remedy: Reduce motor loading also refer to Section 8.3</p>
	<p>Minimum field current not reached ($I_{\text{field act.}} \leq 50\%$ of $I_{\text{field set}}$) Remedy: Check field current Possible cause: 3U-3W phases not correctly connected</p>
	<p>Speed controller monitoring (setpoint-actual value difference > P27 for a time > P43) Possible causes: poor speed controller optimization, tachometer cable interruption, incorrect tachometer polarity</p>
	<p>Drive stalled ($I_A \geq I_{\text{limit}}$ for stationary drive, shutdown time can be selected at parameter P43). The fault message is masked out for setting P43 = 0.</p>
	<p>Gearstage not clear Can only occur when using supplementary boards. Possible cause: Two gearstages simultaneously selected</p>
	<p>Drive does not reach speed in spite of maximum field weakening. The fault can only occur during the field characteristic test Possible causes:- Response voltage P77 set to < 120V - Field current actual value does not follow field current setpoint Remedy: Re-test the field characteristic after checking P77 ¹⁾</p>
	<p>No armature current can flow (e.g. fuse failure, cable interruption etc.) Other possible causes: Field current too high (P76) Response voltage too high (P77) Motor is driven in the 1-quadrant mode (P81) Drive is operating at the a_G limit (e.g. as a result of a supply undervoltage condition)</p>

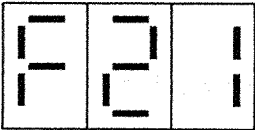
7.2.3 Open-loop control fault

Display	Meaning
	<p>External pulse cancellation is input (board A2: 30A to 600A units, terminal 7 not connected to terminal 8 640A to 1200A units, terminal 16 not connected to terminal 17)</p> <p>For 640 A to 1200 A units, fault F21 is also triggered when the SITOR set fuse monitoring responds. For units connected in parallel, relay K5 also drops out when a fuse fails in the parallel SITOR set.</p>

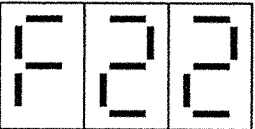
7.2.4 Internal fault messages

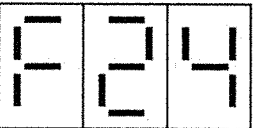
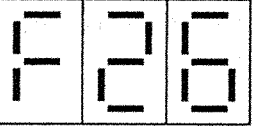
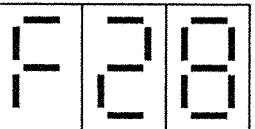
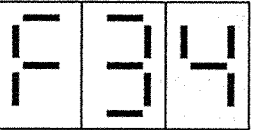
Display	Meaning
	Coupling between the SINEC L1 interface board Z1001 and basic unit is faulted
	Coupling to the supplementary boards Z1004 (technology board) or Z1011 (interface board) faulted. For more detailed information, refer to the operating instructions of the Z1004 and Z1011 boards
	Is only used for the spindle positioning option (main spindle drive 6RA27..). (possible cause: Parameter E00 incorrectly set)
	<p>Current cannot be reduced EMF is too high Remedy, without field weakening: Reduce field current (P76) with field weakening: Reduce P77 and execute field characteristic test 1)</p>
	<p>FIFO overflow Possible cause: - Fault on the electronics board (slot A1) (synchronization, current = 0-message)</p>
	<p>EEPROM fault (cyclic comparison RAM / EEPROM) Check: Jumper 5 must be inserted on module A1200-L12 (up to version 03 or C1,...). The EB-EC setting must be set on the plug-in jumper EA-EB-EC on board A1200-L12 (from version 04 or D1,... onwards) Also refer to Section 5.9!</p>

An equipment error is present if F28 or F34 cannot be acknowledged (replace board A1200).

7.2.5 Start-up faults

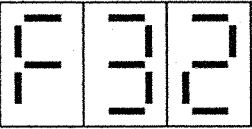
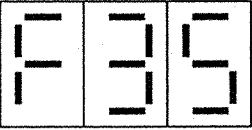
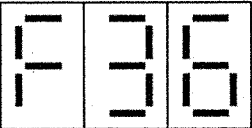
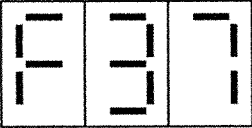
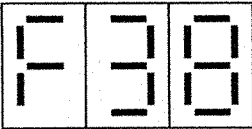
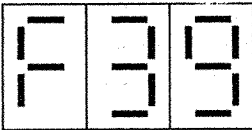
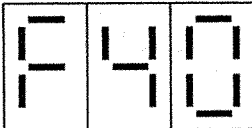
Display	Meaning
	<p>Faults at the field characteristic test ¹⁾</p> <p>Faults can only occur during the field characteristic test.</p> <p>Possible causes: - Load surge during the characteristic test - Electronics board fault</p> <p>Remedy: Repeat the field characteristic test</p>
	<p>Optimization run:</p> <p>Remanence too high (drive rotates at $i_{field_set} = 0$)</p> <p>Remedy: Lock motor</p>
	<p>Fault in the field weakening mode:</p> <p>is triggered, if EMF_{set} is not 0 and no characteristic has been tested.</p> <p>Remedy: Execute field characteristic test ¹⁾</p>
	<p>Optimization run:</p> <p>Current limit too low, the current limit is reached at automatic optimization.</p> <p>Remedy: Current limits (P39 and P41) should only be temporarily increased for the optimization run.</p> <p>Note: Optimization should be carried out manually for large moments of inertia, refer to Section 5.7</p>
	<p>Optimization run is externally interrupted (e.g. STOP)</p> <p>Remedy: Repeat optimization run.</p>
	<p>Hardware is not suitable for the option set with E00 or the options set at parameter E00 are mutually exclusive</p> <p>Remedy: Set parameter E00</p>
	<p>Optimization run with active permanent memory inhibit not possible.</p> <p>Remedy: Set P87 to x3x or x0x</p>
	<p>Erroneous input for the automatic parameter calculation for speed-dependent current limiting. Not available for SIMOREG.</p> <p>Remedy: Do not set parameter P51 to 6</p>

1) Field characteristic test: P90 = x2,
 set P51 = 5 and
 execute instructions in Section 5.5.3, Points 70 to 75.

7.2.6 Power section faults

NOTE

This group of fault messages can only occur when the thyristor check is activated via parameter E39. If the "defective thyristor" is signaled, the applicable thyristor module should be replaced. Although thyristor failure is occasionally possible, repeated fault messages signify a possible problem in another area.

- Possible causes:
- Interruption in the snubber circuitry
 - Current controller and feed forward control not optimized
 - Cooling not guaranteed (e.g. fan not operational, ambient temperature too high, air intake too low, heatsink dirty)
 - Voltage spikes on the supply network too high
 - External short-circuit or ground fault (check armature circuit)

If "thyristor cannot be triggered", is signaled, this is generally caused by a fault in the gating circuit and not by a defective thyristor.

- Possible causes:
- Gating pulse cable to the applicable thyristor broken
 - Ribbon cable X100 incorrectly inserted or interrupted
 - Defective electronics or control board
 - Internal interruption of the gate lead in the thyristor module

For units >600A the following is valid:

V1 ... V6	△	SITOR module A11 ... A16
G11 ... G16	△	G1.1 ... G1.6
G21 ... G26	△	G2.1 ... G2.6

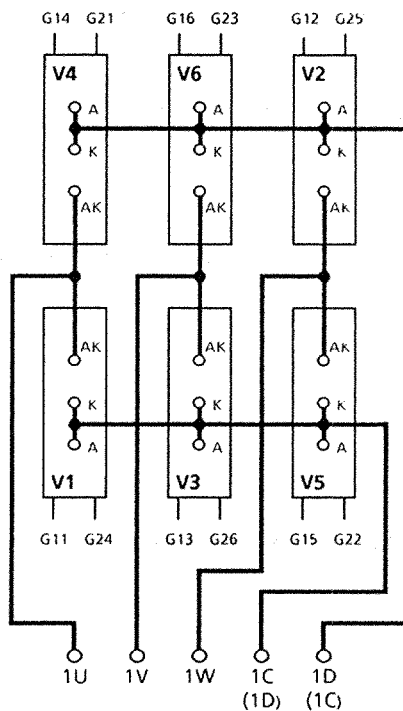

Thyristor module arrangement

Units 30A to 250A

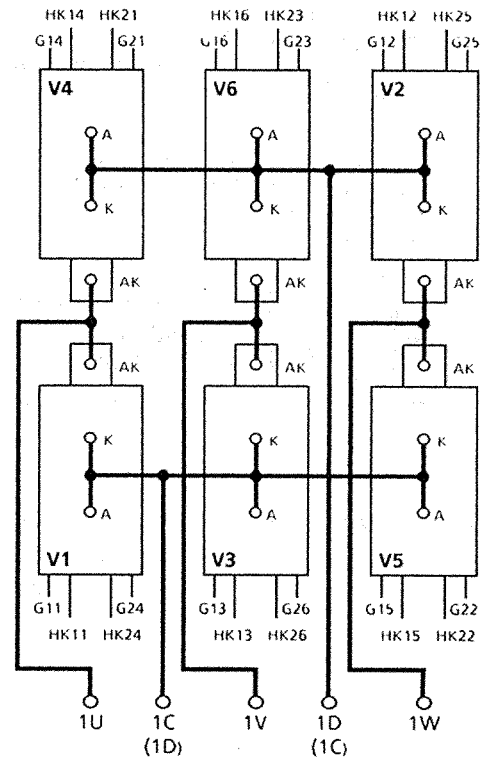

Units 400A to 600A

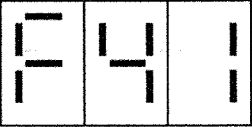

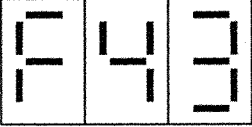
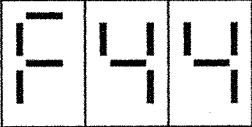
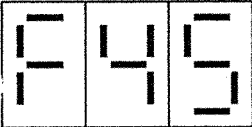
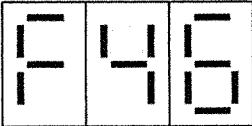
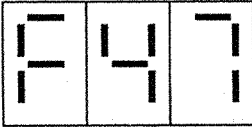
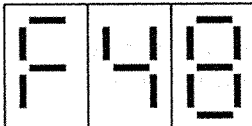
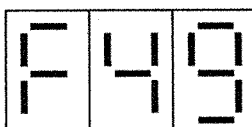
Display	Meaning
	Defective thyristor Short-circuit in thyristor module V1
	Defective thyristor Short-circuit in thyristor module V2
	Defective thyristor Short-circuit in thyristor module V3
	Defective thyristor Short-circuit in thyristor module V4
	Defective thyristor Short-circuit in thyristor module V5
	Defective thyristor Short-circuit in thyristor module V6
	2 or more thyristors not able to be triggered (T I) Possible causes: <ul style="list-style-type: none"> 1. Armature circuit interrupted (check DC fuses, motor leads and brushes) 2. Interruption in the X100 ribbon cable 3. External pulse cancellation issued (refer to F21) 4. Defective electronics board
	2 or more thyristors not able to be triggered (T II) Possible causes: <ul style="list-style-type: none"> 1. Armature circuit interrupted (check DC fuses, motor leads and brushes) 2. Interruption in the X100 ribbon cable 3. External pulse cancellation issued (refer to F21) 4. Defective electronics board
	I = 0 - message, defective Possible causes: Electronics board defective or external noise effects (e.g. contactor without RC network)

Display	Meaning
	<p>Thyristor not able to be triggered (gate G11) Possible causes: Gate lead interrupted, defective electronics board or gating board, internal gate interruption in the thyristor For units >600A: Fuse failure in SITOR module A11</p>
	<p>Thyristor not able to be triggered (gate G12) Possible causes: Gate lead interrupted, defective electronics board or gating board, internal gate interruption in the thyristor. For units >600A: Fuse failure in SITOR module A12</p>
	<p>Thyristor not able to be triggered (gate G13) Possible causes: Gate lead interrupted, defective electronics board or gating board, internal gate interruption in the thyristor. For units >600A: Fuse failure in SITOR module A13</p>
	<p>Thyristor not able to be triggered (gate G14) Possible causes: Gate lead interrupted, defective electronics board or gating board, internal gate interruption in the thyristor. For units >600A: Fuse failure in SITOR module A14</p>
	<p>Thyristor not able to be triggered (gate G15) Possible causes: Gate lead interrupted, defective electronics board or gating board, internal gate interruption in the thyristor. For units >600A: Fuse failure in SITOR module A15</p>
	<p>Thyristor not able to be triggered (gate G16) Possible causes: Gate lead interrupted, defective electronics board or gating board, internal gate interruption in the thyristor. For units >600A: Fuse failure in SITOR module A16</p>
	<p>Thyristor not able to be triggered (gate G21) Possible causes: Gate lead interrupted, defective electronics board or gating board, internal gate interruption in the thyristor. For units >600A: Fuse failure in SITOR module A14</p>
	<p>Thyristor not able to be triggered (gate G22) Possible causes: Gate lead interrupted, defective electronics board or gating board, internal gate interruption in the thyristor. For units >600A: Fuse failure in SITOR module A15</p>

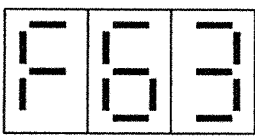
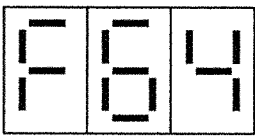
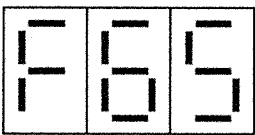
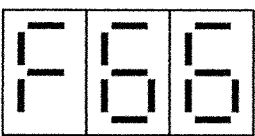
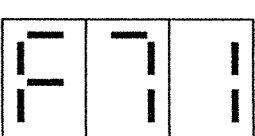
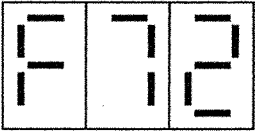
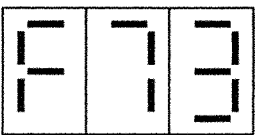
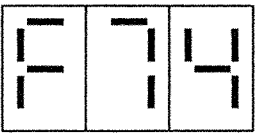
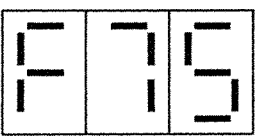
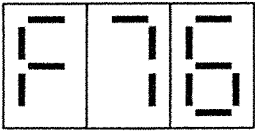
Display	Meaning
	<p>Thyristor not able to be triggered (gate G23) Possible causes: Gate lead interrupted, defective electronics board or gating board, internal gate interruption in the thyristor. For units >600A: Fuse failure in SITOR module A16</p>
	<p>Thyristor not able to be triggered (gate G24) Possible causes: Gate lead interrupted, defective electronics board or gating board, internal gate interruption in the thyristor. For units >600A: Fuse failure in SITOR module A11</p>
	<p>Thyristor not able to be triggered (gate G25) Possible causes: Gate lead interrupted, defective electronics board or gating board, internal gate interruption in the thyristor. For units >600A: Fuse failure in SITOR module A12</p>
	<p>Thyristor not able to be triggered (gate G26) Possible causes: Gate lead interrupted, defective electronics board or gating board, internal gate interruption in the thyristor. For units >600A: Fuse failure in SITOR module A13</p>
	<p>Thyristor cannot be turned-off (gate G11 or G21) Remedy: Replace thyristor modules V1 and V4</p>
	<p>Thyristor cannot be turned-off (gate G12 or G22) Remedy: Replace thyristor modules V2 and V5</p>
	<p>Thyristor cannot be turned-off (gate G13 or G23) Remedy: Replace thyristor modules V3 and V6</p>
	<p>Thyristor cannot be turned-off (gate G14 or G24) Remedy: Replace thyristor modules V1 and V4</p>
	<p>Thyristor cannot be turned-off (gate G15 or G25) Remedy: Replace thyristor modules V2 and V5</p>
	<p>Thyristor cannot be turned-off (gate G16 or G26) Remedy: Replace thyristor modules V3 and V6</p>

8 Setting supplementary functions (selection)

8.1 Set current limits

P39 = B + for T I

P40 = B - for T II

Ratio = Required limiting current/ $I_{\text{motor rated}}$ in % (max. 300% possible)

Optional second parameter set (P41 and P42) for current limit changeover, refer to selector terminals X1.19 and X1.20.

NOTE

The unit output current is automatically limited to the rated unit current according to the rating plate.

8.2 Speed-dependent current limiting

P48 = Intervention point in % of n_{max}

P49 = Current limiting value in % of I_{motor} at maximum speed

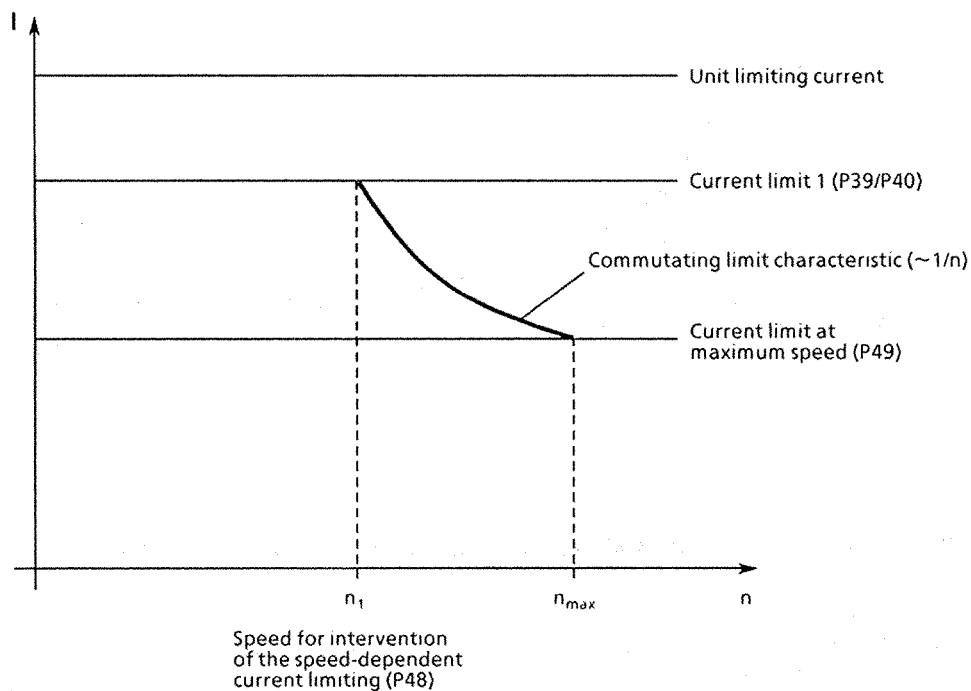

8.3 Thermal overload protection of the DC motor (I²t monitoring)

The I²t monitoring parametrization is realized using parameters P70 and P71. With suitable adaption, the motor is protected from inadmissible loading (not complete motor protection).

Adaption

P70: A time constant T_{motor} must be entered in minutes into parameter P70 with which the I²t monitoring should operate.

P71: The ratio of the rated motor current to the equipment limiting current is entered into parameter P71 in percent, according to the rating plate.

Pre-warning characteristic / shutdown characteristic

The prewarning message (only when using supplementary boards, e.g. Z1210) responds after a time constant has expired (P70) if the motor is, for instance, constantly loaded with approximately 125% of the rated motor current. If the load is not reduced, the drive is shutdown and fault message F13 flashes when the drive shutdown characteristic has been reached.

Pre-warning/shutdown times for other loads can be taken from the diagram.

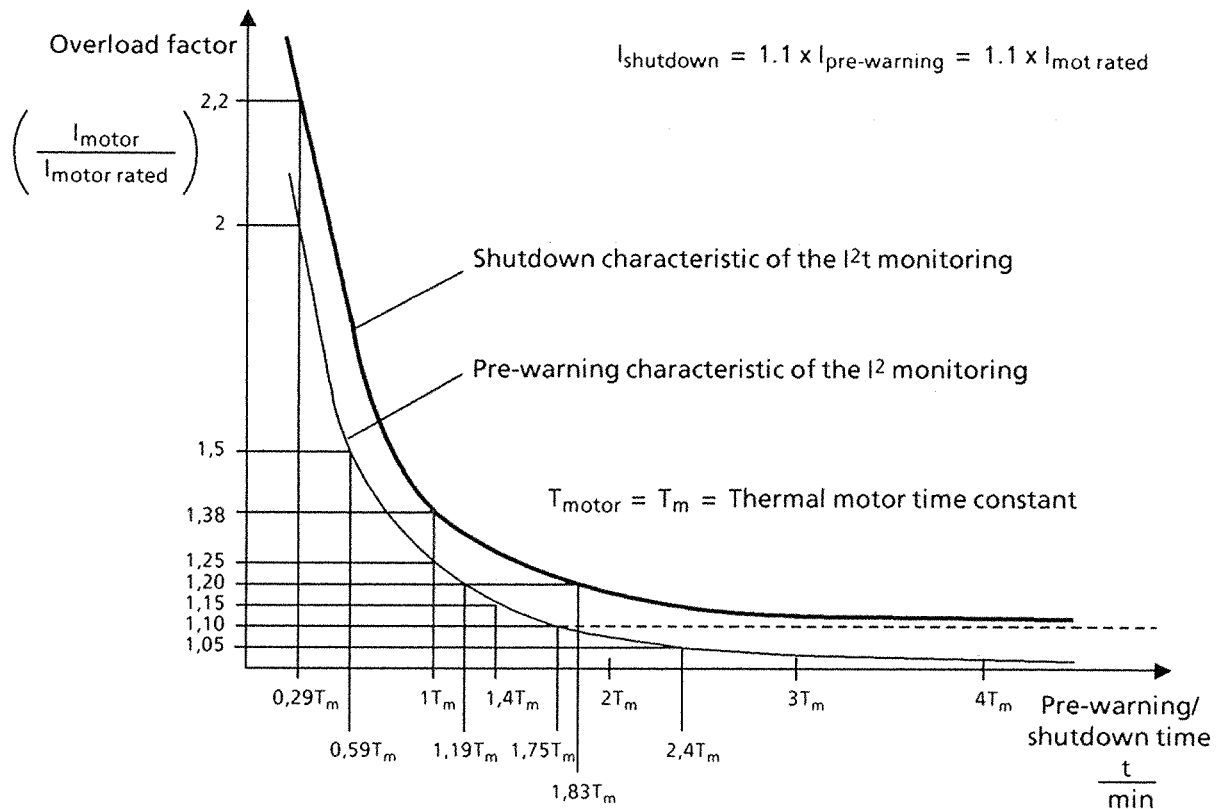

NOTE

- The calculated pre-loading of the motors is lost when the electronics power supply fails. After the converter switches on again it is assumed that the motor is unloaded!
- The I²t monitoring provides only a rough approximation of the thermal image of the motor (complete motor protection is not provided).
- If zero is set in P70 (T_{motor}), the I²t monitoring is switched-out.

Determining the thermal equivalent time constants

It should be noted that the thermal equivalent time constants are dependent on the maximum overcurrent.

Thermal equivalent time constants of DC motors 1G . 5/1H.5, according to Catalog DA12.

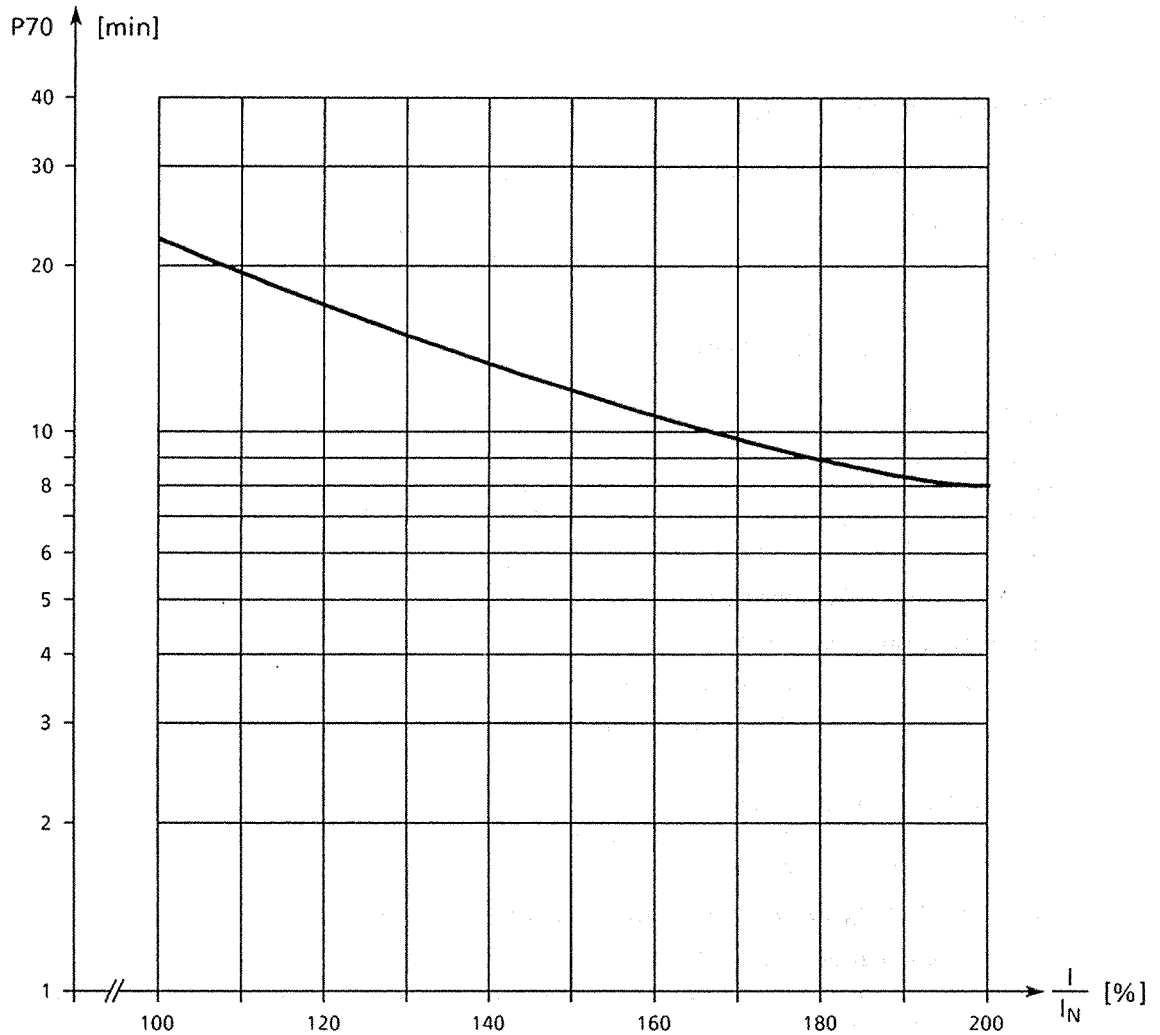

NOTE

The manufacturer's specifications should be observed when using other motor types.

8.4 Standstill monitoring using relay K1

P80 = 1 Relay K1 as $n < n_{\min}$ signal

P21 = Set threshold, e.g. 1% of n_{\max}

Relay K1 pulls-in at speeds below 1%.

Relay K2 can also be used for fault signaling. A fault condition exists if terminal X1.17 (ON) is energized, and relay K2 (load contactor "on") is not energized (display F . .).

8.5 Reduced gearbox wear

P62, setting the current setpoint integrator (0 - 100ms)

The reduced gearbox wear is effective at torque direction changes. The setpoint is fed to the current controller through a ramp-function generator (P62).

8.6 Special "crawl" function

Prerequisites:

Crawl setpoint available in P13

Set terminal 19 to inch 1 (P83 = 1)

Set terminal 20 to inch 2 (P84 = 2)

Terminal 18 (controller enable) must be energized

Terminals 19 and 20 must be simultaneously energized for the "crawl" function..

Terminal 17 open-circuit (L signal):

H signal at terminals 19 and 20:

Main contactor (relay K2) energized, accelerate to crawl setpoint via the ramp-function generator

L signal at terminals 19 and 20:

$n < n_{\min}$ via the ramp-function generator, controller inhibit, main contactor off after $i = 0$ (relay K2)

Terminal 17 energized with H signal, the drive operates with the main setpoint:

H signal at terminals 19 and 20:

Drive decelerates from the operating speed to crawl speed along the ramp-function generator ramp

L signal at terminals 19 and 20:

Drive accelerates from crawl speed to operating speed along the ramp-function generator ramp (main setpoint)

8.7 Stall protection

Shutdown time can be set using P43: 0 - 20s (from SW 3.3, 0-60s)

The following conditions exist if the monitoring responds:

- Speed actual value is $< 0.4\%$ of n_{\max}
- Current setpoint has reached the current limit
- Speed-controlled operation
- Unit signals F16 after the time set in P43 expires.

The fault message is masked out when parameter P89 = 3 (current-controlled operation).

If the speed controller is overdriven and the unit is controlled through the current limit (master-slave changeover), the monitoring must be disabled (refer to Section 8.14).

P43 = 0: F16 stall protection masked out.

8.8 Ramp-function generator

Set ramp-function generator

P16 = T+ ... Ramp-up time 1 0 - 300s
P17 = T- ... Ramp-down time 1 0 - 300s
P18 = AR ... Initial rounding off 1 0 - 10s
P19 = ER ... Final rounding off 1 0 - 10s

A second ramp-function generator E16-E19 can be selected when using supplementary boards, e.g. Z1210.

Supplementary functions to the ramp-function generator via selector terminals X1.19 or X1.20

- Ramp-function generator HOLD: The ramp-function generator output is held at its current value
- Ramp-function generator enable: When the ramp-function generator enable signal is not available, the ramp-function generator output is set to zero, which, for 4-quadrant units, causes the drive to brake along the current limit.
- The speed actual value can be prevented from overshooting after setpoint steps at the ramp-function generator input using the following measures:
The speed-controller integral-action time is multiplied by a factor when the ramp-function generator runs. This factor can be set using the ten's digit of parameter P89.

P89 = 0x ... Factor	1 (i.e. function switched-out)
1x ... Factor	3
2x ... Factor	10
3x ... Factor	30
4x ... Factor	100
5x ... Factor	300
6x ... Factor	1000
7x ... Factor	0 (i.e. speed controller integrator is set to 0)
8x ... Factor	1 (i.e. function switched-out)
9x ... Factor	900

The adaption is only effective when the ramp-function generator is active (P16 <> 0, P17 <> 0)

The actually effective integral-action time is internally limited to a max. 100 s!

Further ramp-function generator operating modes can be taken from the parameter description for parameter P14.

8.9 Speed controller adaption

Selecting the speed controller adaption mode

- E80 = xx0 ... Adaption disabled
 xx1 ... SID-dependent adaption (SID = speed setpoint-actual value difference)
 xx2 ... Current-dependent adaption
- x0x ... Adaption disabled
 x1x ... Adaption effective in gearstage I
 x2x ... Adaption effective in gearstages I and II
 x3x ... Adaption effective in gearstages I, II and III
 x4x ... Adaption effective in gearstages I, II, III and IV
- 0xx ... No gearstage adaption of the adaption parameter
 1xx ... Gearstage adaption of the adaption parameters E81 and E82

Stage	I	II	III	IV
KPN = (P gain)	E81	$E81 \times \frac{P33}{P31}$	$E81 \times \frac{P35}{P31}$	$E81 \times \frac{P37}{P31}$
TNN = (Integral-action time)	E82	$E82 \times \frac{P34}{P32}$	$E82 \times \frac{P36}{P32}$	$E82 \times \frac{P38}{P32}$

- Parameter E81: (0 ... 200 in 0.1 steps)
 P gain for SID / I > threshold 2 and n < E85
- Parameter E82: (0 ... 10.0 sec in 0.1 steps)
 Integral-action time for SID / I > threshold 2 and n < E85
- Parameter E83: (0 ... 100% SID or current in 0.1 steps)
 Threshold 1 (armature current or setpoint-actual value difference)
- Parameter E84: (0 ... 100% SID or current in 0.1 steps)
 Threshold 2 (armature current or setpoint-actual value difference)
- Parameter E85: (0 ... 100% of n_{max})
 Speed limit for the adaption range; adaption is not effective above this speed; transition range from E85 to E85 + 5% of n_{max}

Graphic representation of "load adaption"

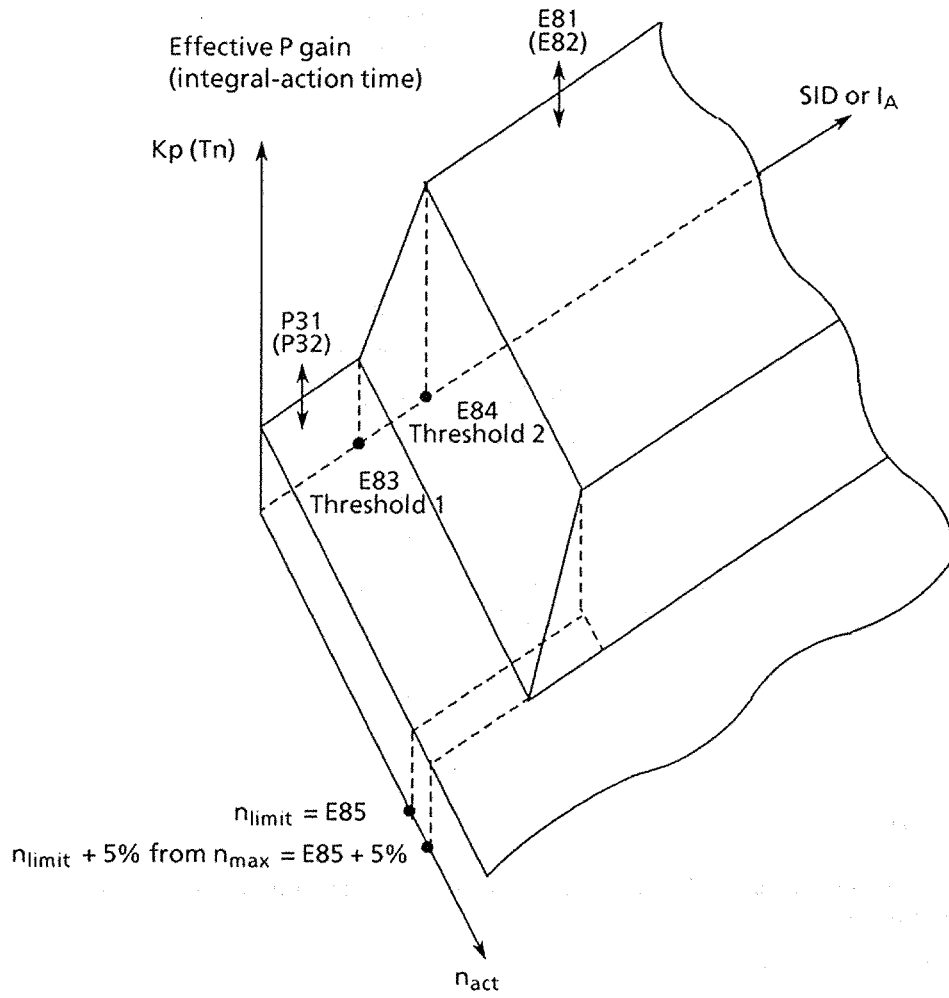

8.10 Operation without tachometer (EMF closed-loop control)

External armature voltage sensing should be provided for operation without tachometer (e.g. DC/DC converter U312, Order No. 6RA8222-8GA0).

The voltage converter output is fed to the tachometer actual value input through a smoothing element. The $I_A \times R_A$ compensation is realized via parameter E33.

Circuit recommendation:

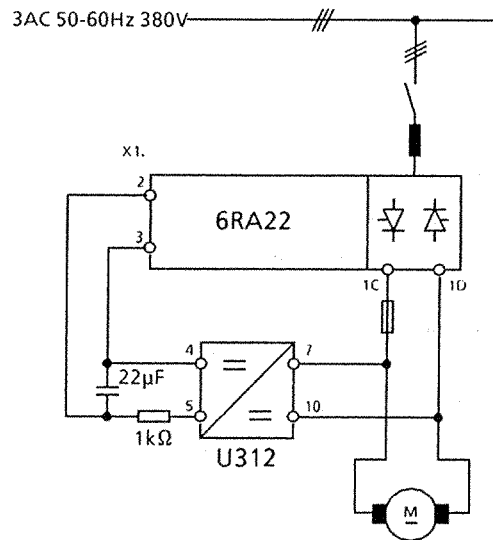

Start-up:

1. Execute speed actual value adjustment with the motor under no-load conditions (refer to Section 5.5)
2. Measure motor speed
3. Increase the setting of parameter E33, until the speed of the loaded motor is the same as the no-load speed.

NOTE

Field-weakening control is not possible without a tachometer.

Set P77 = 0!

8.11 Torque control

In the armature control range, i.e. the motor field is constant over the complete speed range, the unit current is directly proportional to the motor torque.

From software release 3.1 of the basic unit onwards, it is possible to operate the drives, torque-controlled even in the field-weakening range. The speed controller output corresponds to the torque setpoint. This value is divided by the actual motor flux, and fed to the current controller as setpoint.

Selecting the mode for torque control

- E70 =** xx0... Current control
xx1... Torque control (i.e. the speed controller output is divided by the actual magnetic motor flux)
- x0x... Analog limiting via terminal X1.8 operates as current limiting
x1x... Analog limiting via terminal X1.8 operates as torque limiting

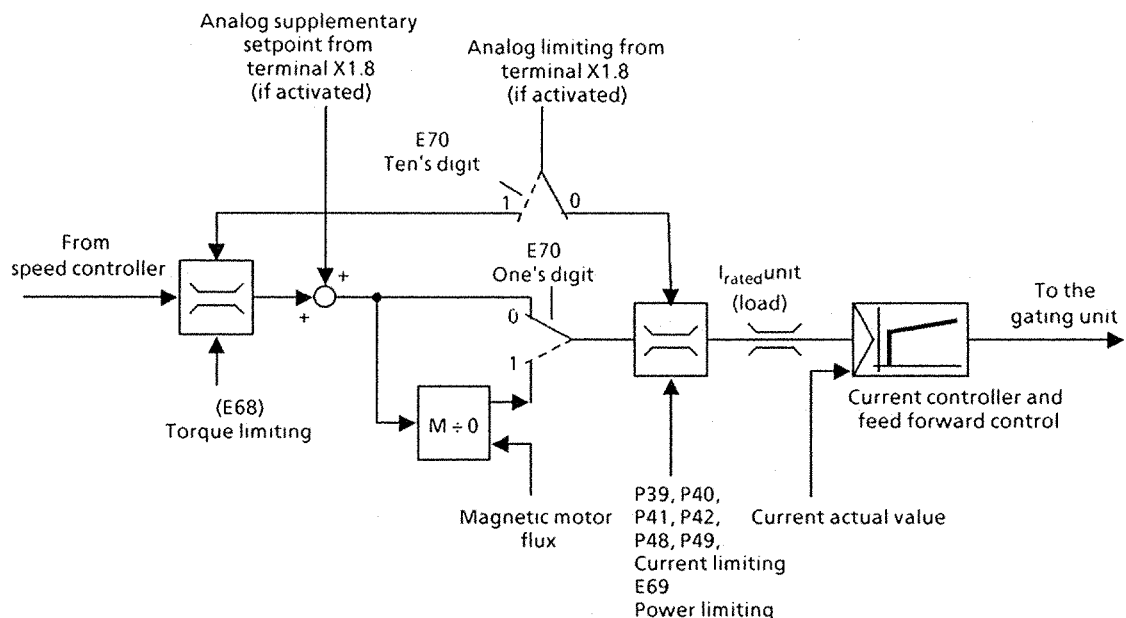

Further setting possibilities are provided when supplementary boards are used

8.12 Changeover from speed to current controlled operation

8.12.1 Changeover using parameter P89

- P89 = 0 the unit operates speed controlled
P89 = 3 the unit operates current controlled
(the ramp-function generator remains effective, if necessary set P16... P19 = 0)

8.12.2 Changeover from speed control/current control via selector terminal

Contrary to current-controlled operation with parameter P89 = 3, in this case, the speed control/current control changeover can be realized during operation.

with P83 = 9 terminal X1.19: LOW ... speed control
HIGH ... current control

or

with P84 = 9 terminal X1.20: LOW ... speed control
HIGH ... current control

P85 ≠ 11 Current setpoint for current control from terminals X1.4 and X1.6
Speed setpoint for speed control from terminals X1.4 and X1.6

P85 = 11 Current setpoint for current control from terminal X1.8
Speed setpoint for speed control from terminals X1.4 and X1.6
For current control, a positive voltage corresponds to torque direction I

If several terminals are parametrized as speed control/current control, they are logically OR'd (current control is selected if one of the terminals is energized).

The ramp-function generator is effective in both the speed-controlled as well as current-controller operation. Zero current setpoint is immediately input in the current-controlled mode after terminal X1.17 is opened (stop signal), the main contactor drops out when the speed $|n < n_{min1}|$ is reached.

Current setpoint normalization

Terminals X1.4 and X1.6: 10V corresponds to the rated unit current for E01 = 100

Terminal X1.8: 10V corresponds to a rated unit current for E02 = 100

8.12.3 Master-slave changeover

This function is available from software release 3.3 onwards.

Contrary to current-controlled operation with parameter P89 = 3, in this case, the speed control/current control changeover can be realized during operation.

with P83 = 11 terminal X1.19: LOW ... speed control (master drive)
HIGH ... current control (slave drive)

or

with P84 = 11 terminal X1.20: LOW ... speed control (master drive)
HIGH ... current control (slave drive)

P85 ≠ 11 Current setpoint for current control from terminals X1.4 and X1.6
Speed setpoint for speed control from terminals X1.4 and X1.6

P85 = 11 Current setpoint for current control from terminal X1.8
Speed setpoint for speed control from terminals X1.4 and X1.6
For current control, a positive voltage corresponds to torque direction I

If several terminals are parametrized as master-slave drive, they are logically OR'd (slave drive is selected if one of the terminals is energized).

The ramp-function generator is only effective in speed-controlled operation; in current-controller operation, the ramp-up and ramp-down times are set to zero.

In the current-controlled mode, zero current setpoint is input only when $n < n_{min1}$ is reached after terminal X1.17 is opened (stop signal), and the main contactor opened. Thus, the drive can be braked via the master drive. Thus, the master drive provides the slave drive with the current setpoint.

Current setpoint normalization

Terminals X1.4 and X1.6: 10V corresponds to the rated unit current for E01 = 100

Terminal X1.8: 10V corresponds to a unit rated current for E02 = 100

8.13 Operation on weak supply networks

- e.g.
- high harmonic content
 - fast frequency change
 - low supply network fault levels
 - diesel generator supply (isolated operation)
 - long commutation notches

The supply network characteristics listed above can mean that faults F03 or F11 sporadically occur.

From software release 3.2 onwards, the following supplementary setting possibilities are available:

- Behavior on line networks with frequency instability

Frequency rate of change can be set by

Parameter L33, one's digit:

- L33 = xx0 ... stiff supply networks (normal setting)
- xx1 ... weak supply networks
- xx2 ... weak supply networks
- xx3 ... weak supply networks (high number corresponds to faster rate of change)

- Tachometer interruption monitoring

The response threshold for fault message F11 can also be set through

Parameter L33, ten's digit:

- L33 = x0x ... response threshold = 60V x P98/380
- x1x ... response threshold = 120V x P98/380
- x2x ... response threshold = 180V x P98/380
- x3x ... response threshold = 240V x P98/380

The setting L33 = 022 is recommended for operation on diesel generator supply networks.

NOTE

- When the response threshold for the tachometer monitoring is increased, the unit only shuts down at a higher speed when the tachometer actually fails.
- A higher armature current ripple can occur when the frequency rate of change is increased.

- Correction of the synchronizing filter phase shifting

Fault messages (F03, F11) can occur for supply networks having significant harmonics.

Parameter L34: $-199 \dots +199 \times 10 \mu\text{s}$ additional phase shifting

Setting instructions: P89 = 3 (current-controlled operation)

P76 = 0 (field current setpoint is zero)

input current setpoint >2% at terminal X1.4

Read-out contents of parameter P07 (EMF)

Adjust L34 until the contents of P07 = 0

Parameter L33 is mainly set, as the harmonic contents of the supply network are generally not constant.

8.14 Switching-out monitoring functions



WARNING

The monitoring functions incorporated in the unit serve to protect the equipment and the safety of the installation. If monitoring functions are to be switched-out, this can cause the unit to either not respond, or respond incorrectly to fault conditions. This can lead to loss of life, severe injuries or property damage.



The resulting damage to the equipment is not part of the warranty conditions.

Only qualified personnel, who have detailed knowledge of all the safety instructions contained in these operating instructions, as well as installation, operating and maintenance instructions, should work on this unit.

Each individual monitoring function which can be switched-out, is assigned one bit in a control register (parameter 91). The required bit pattern must be input in hexadecimal form. The conversion tables below can be used to determine the hexadecimal number.

Bit No.	11	10	9	8	7	6	5	4	3	2	1	0
Fault No.	F26	F19	F17	F16	F14	F07	F11	F05	F04	F03	F02	F23
	1)				2)				2)			
Example	1	1	0	0	0	0	1	0	0	1	0	0
	Hundred's digit				Ten's digit				One's digit			
	C				2				4			

from P91

Bit = 0 ... monitoring active
Bit = 1 ... monitoring switched-out

Example: P91 = C24, i.e. F03, F11, F19 and F26 masked-out

Bit pattern	Hexadecimal
0000	0
0001	1
0010	2
0011	3
0100	4
0101	5
0110	6
0111	7

Bit pattern	Hexadecimal
1000	8
1001	9
1010	A
1011	B
1100	C
1101	D
1110	E
1111	F

- 1) from software release 1.9 onwards
- 2) from software release 3.1 onwards

Switching-out additional monitoring functions

- F10 (overspeed protection) can be switched-out via parameter E21 = 0 (from software release 1.9 onwards)
- F13 (I²t monitoring) can be switched-out via parameter P70 = 0.
- F15 (speed controller monitoring) can be disabled using parameter E03 = 1x.
- F16 (stall protection) can also be switched-out via parameter P43 = 0. (from software release 1.5 onwards)
- F34 (EEPROM fault) can be switched-out via parameter P87 = x1 or x2 (permanent memory inhibit active). (from software release 1.9 onwards). Also refer to Section 5.9.

8.15 Software replacement

Procedure when upgrading a SIMOREG unit with a new software release

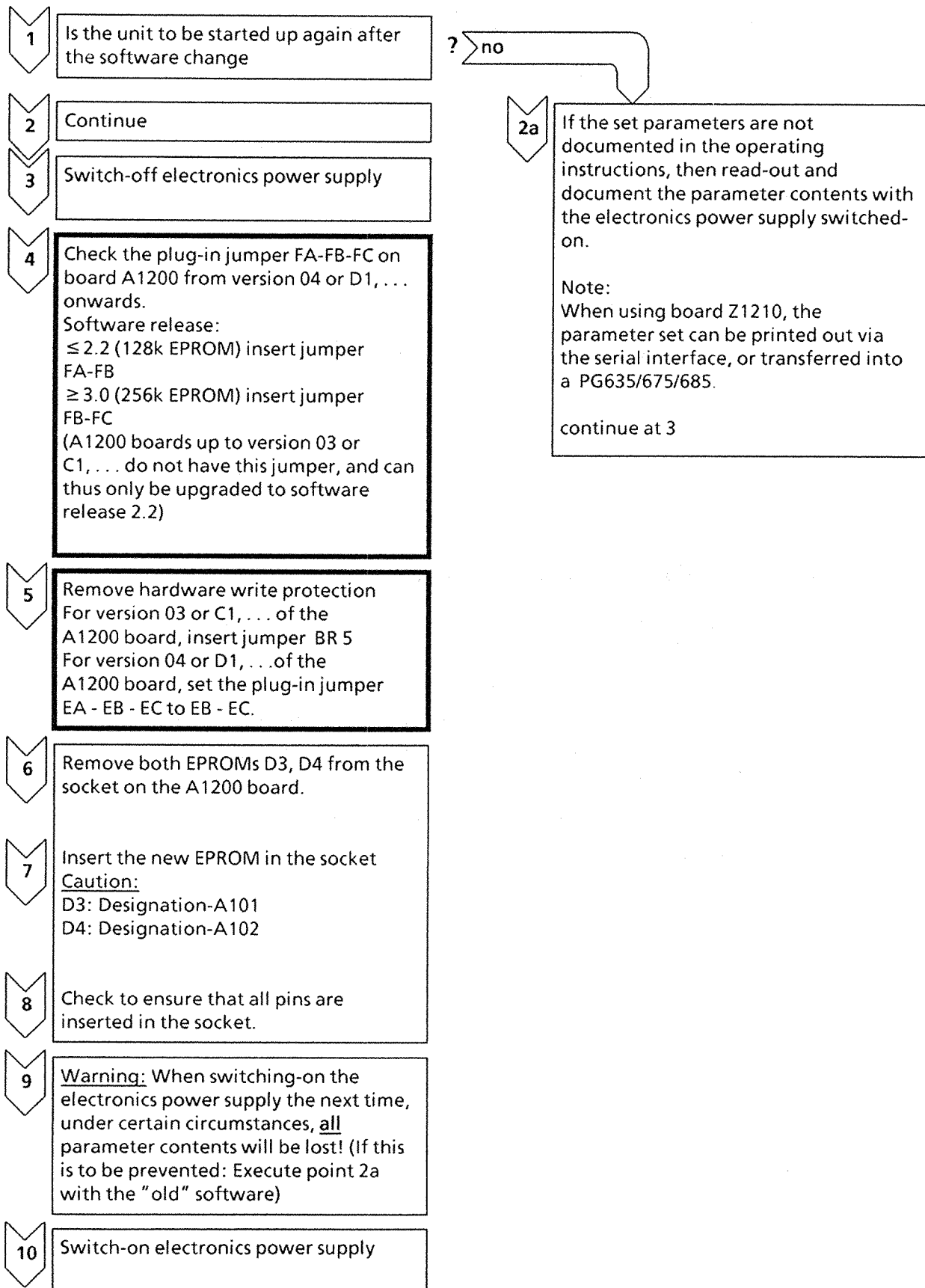

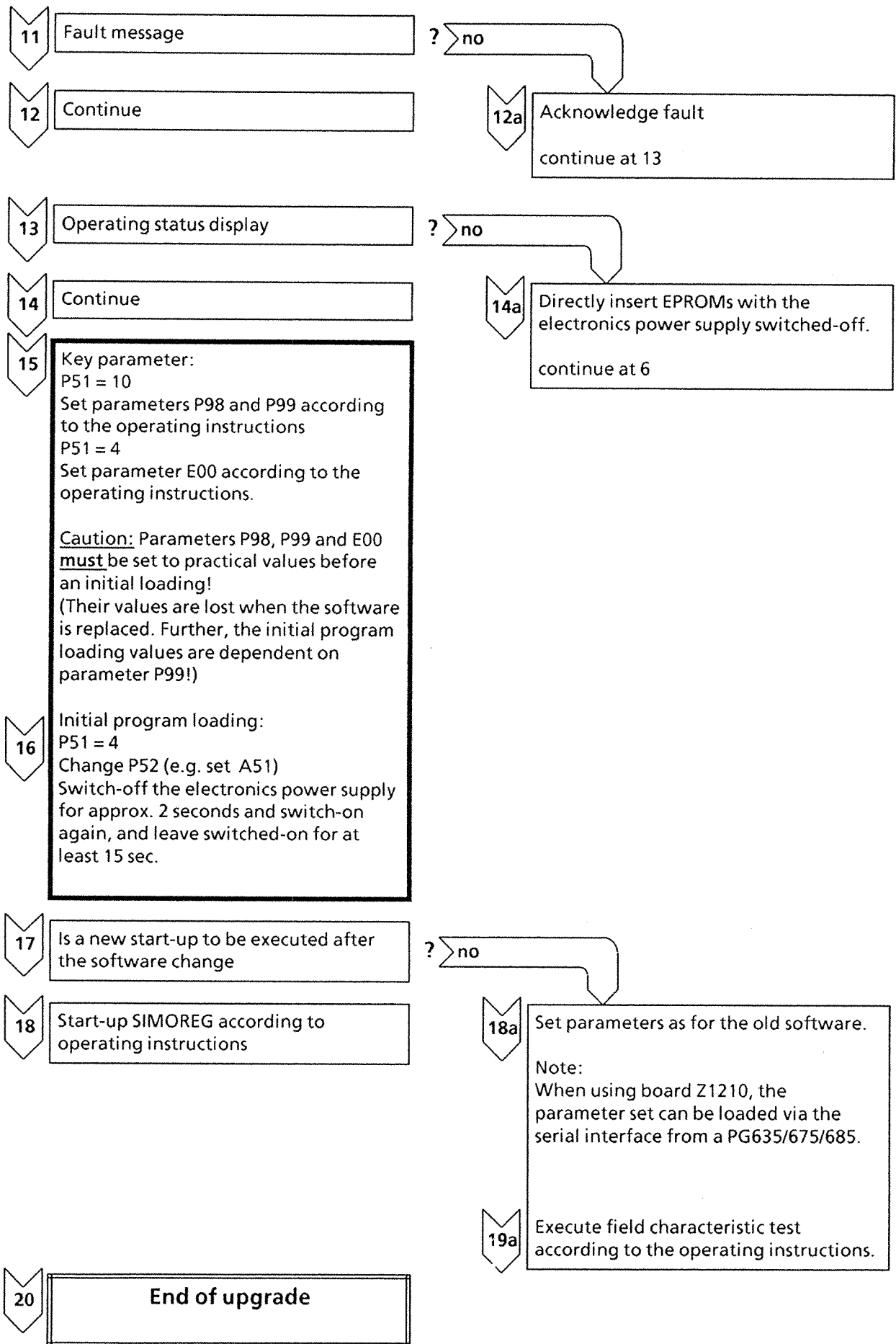

9 Parameter list

The following parameter list involves the parameters of the basic unit.

Additional parameters, which are required in conjunction with supplementary boards are documented in the applicable operating instructions.

Note

When using the Z1004 technology board, the basic unit parameters can be preset or changed from the technology board, depending on the technology module used (EPROM on Z1004). The corresponding parameters are documented in the manual for the Z1004 technology board.

Parameter No.	Boot value	Value range (steps)	Dim.	Function
P00				Operating status display (Section 6)
P01	-	-199 - + 999 of n_{max} (0.1)	%	Speed setpoint display, the sum of the setpoint inputs at terminals 4 and 6 is displayed; for E01 = 100 , 10V = 100%)
P02	-	-199 - + 999 of n_{max} (0.1)	%	Speed actual value display, as a ratio of the maximum speed
P03	-	0 - 100 (0.1)	%	Armature current setpoint display in % of the rated unit current (as absolute quantity)
P04	-	0 - 100 (0.1)	%	Armature current actual value display in % of the rated unit current (as absolute quantity)
P05	-	0 - 180 (0.1)	Deg.	Firing angle of the gating unit
P06	-	0 - 100 (0.01)	%	Current controller integrator display; is used to check the setting of the feed forward control, 100% means a deviation of the firing angle α of 60°; also refer to P82 = 7 Values in the vicinity of zero are obtained when the feed forward control is correctly set.
P07	-	0 - 999	V	Calculated EMF display (as absolute quantity). Analog EMF values are output in the form of -10V to + 10V, using P82 = 8 (at terminal 14).
P08	-	0 - 999	V	Armature voltage U_d display (as absolute quantity)
P09	-	-199 - + 999 (0.1)	%	Analog input display for terminal 8 (100% at 10VxE02:100)

Parameter No.	Boot value	Value range (steps)	Dim.	Function
P10	-	0 - 999	V	Display of RMS supply voltage
P11	2.0	-100 - + 100 of n_{max} (0.1)	%	Speed setpoint, inching 1 Positive values for forwards inching
P12	-2.0	-100 - + 100 of n_{max} (0.1)	%	Speed setpoint, inching 2
P13	2.0	-100 - + 100 of n_{max} (0.1)	%	Crawl setpoint
P14 *)	001	000 - 211	Hex	<p><u>Operating mode for inching:</u></p> <p>P14 = xx0: The inching setpoints are fed to the ramp-function generator input.</p> <p>P14 = xx1: The inching setpoints are fed directly to the speed controller input, bypassing the ramp-function generator.</p> <p><u>Operating mode for the ramp-function generator :</u></p> <p>P14 = x0x: (standard setting) Ramp-function generator correction effective</p> <p>P14 = x1x: Ramp-function generator correction switched-out (when the current limit is reached, the ramp-function generator is not corrected)</p> <p><u>Operating mode for the ramp-up integrator:</u></p> <p>The ramp-function generator parameters are automatically changed over to other values when the master control voltage (i.e. the setpoint at the ramp-function generator input) is at terminal 17 after the ON command has been applied for the first time.</p> <p>P14 = 0xx: Ramp-function generator (as supplied)</p> <p>P14 = 1xx: Ramp-up integrator: Ramp-up and ramp-down times are 0.</p> <p>P14 = 2xx: Ramp-up integrator: Parameters E16, E17, E18 and E19 are effective.</p>

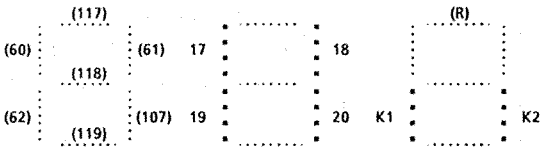
Parameter No.	Boot value	Value range (steps)	Dim.	Function
P14				The drive is braked along the ramp-function generator ramp (parameters P16 to P19) with the STOP signal (terminal 17 open-circuit). Terminal 62 on board Z1210 (changeover to ramp-function generator 2) has priority over the ramp-up integrator function. This means that parameters E16 to E19 are always effective as long as terminal 62 is energized! The motorized potentiometer function has priority over the ramp-up integrator function, this means that the ramp-function generator is always effective as long as the terminal motorized potentiometer ON (= manual mode) is energized!
P15				<p>Status displays of the digital inputs and outputs</p>  <p>The status of the digital input terminals and output relays are displayed using the 7-segment display segments. Segments lit → terminal is energized or relay has pulled-in.</p> <p>Segment 17 lit : Terminal 17 ON</p> <p>Segment 18 lit : Terminal 18 Enable</p> <p>Segment 19 lit : Terminal 19 digital input 3 (selector terminal)</p> <p>Segment 20 lit : Terminal 20 digital input 4 (selector terminal)</p> <p>Segment K1 lit : Relay K1 has pulled-in</p> <p>Segment K2 lit : Relay K2 has pulled-in</p> <p>The segments in brackets are only active when the Z1210 supplementary board is used.</p>
P16	0.00	0.00 - 300 (0.01)	sec	Ramp-function generator, ramp-up time 1
P17	0.00	0.00 - 300 (0.01)	sec	Ramp-function generator, ramp-down time 1
P18	0.00	0.00 - 10.0 (0.01)	sec	Ramp-function generator initial rounding 1; recommended value, 10% of the ramp-up time
P19	0.00	0.00 - 10.0 (0.01)	sec	Ramp-function generator initial rounding 1; recommended value, 10% of the ramp-up time
P20	3	0 - 300	msec	Setpoint-actual value difference filtering, per software. A smoothing of approx. 1 ms is already incorporated using hardware.
P21	0.5	0.0 - 100 of n_{max} (0.1)	%	Setting values for $n < n_{min}$ signal Threshold for main contactor drop out at "Stop" signal (terminal 17 open-circuit)

Parameter No.	Boot value	Value range (steps)	Dim.	Function
P22-26				Speed threshold value when using supplementary boards, e.g. Z1210.
P27	2.0	0.0-60.0 of n_{max} (0.1)	%	Response threshold for the speed controller monitoring (signal via relay K1 or when using supplementary boards, e.g. Z1210).
P28	0	-100 - + 100 of I_{rated}	%	Initial value of the speed controller integrator after controller enable.
P29	0	-100 - + 100 of I_{rated}	%	Supplementary current setpoint, (-) value = T II, (+) value = T I (ineffective, if P89 = 3; current control)
P30	0	-100- + 100	$\frac{\%n_{max}}{163.84}$	Speed controller offset adjustment, effective for speed control P89 = 0 and P89 = 1. Setting 100 corresponds to approx. 0.6% of speed n_{max} .
P31	2.9	0.0 - 200 (0.1)		Speed controller P gain. The speed controller becomes an I controller for gain P31 = 0
P32	0.62	0.00 - 10.0 (0.01)	sec	The speed controller becomes a P controller for speed controller integral-action time P32 = 0 ,
P33-38				Required when using supplementary boards, e.g. Z1210.
P39	100	0 - 300 of $I_{mot rated}$	%	Positive current limit for torque direction I, specified value in percent of the rated motor current, which is normalized using P71. The current is automatically limited to the equipment rated current!
P40	100	0 - 300 of $I_{mot rated}$	%	Negative current limit for torque direction II, otherwise as for P39.
P41	100	0 - 300 of $I_{mot rated}$	%	Positive current limit 2, when using the current limiting changeover function (refer to selector terminals 19 and 20).
P42	100	0 - 300 of $I_{mot rated}$	%	Negative current limit 2
P43	0.5	0.0 - 20.0	sec	Shutdown time for stall protection
P43	0.5	0.0 - 60.0 (0.1)	sec	Shutdown time for stall protection (from SW 3.3 onwards) (0 : stall protection disabled)
P44-47				Required when using supplementary boards, e.g. Z1210.
P48	100	0 - 100 of n_{max}	%	Intervention of the speed-dependent current limiting
P49	100	0 - 300 of $I_{mot rated}$	%	Current limit at maximum speed (n_{max})

Parameter No.	Boot value	Value range (steps)	Dim.	Function
P50	0	0 - 100 of n_{max}	%	Changeover speed from current limit 1 to current limit 2, if current limit 2 is selected via selector terminal.
P51	0	0 - 999		<p>Key parameter:</p> <p>P51 = 0: Normal operation, only the key parameter itself can be changed. P51 = 0 is always set when switching-out the power supply 2U, 2W.</p> <p>P51 = 1: Normalization of display parameters P01 to P10. The displayed value can be changed by depressing the raise/lower keys. The conversion factor obtained (displayed values/actual physical quantity) remains subsequently stored.</p> <p>P51 = 2: Optimization run in 3 sections: 1st section: Feed forward control and current controller 2nd section: Speed controller 3rd section: Field characteristic test</p> <div style="border: 1px solid black; padding: 5px; margin: 10px 0;"> <p>NOTE</p> <p>If the optimization run is required, then the RAISE key should be depressed after the display OP = . The optimization run is not executed when the LOWER key is depressed.</p> </div> <p>P51 = 3: Procedure as for P51 = 2, however only the 2nd section (speed controller optimization) of the optimization is executed.</p> <p>P51 = 4: Parameter P11 - P79 and all E- and H (U)- parameters can be changed.</p> <p>P51 = 5: Field characteristic test: Procedure as for P51 = 2 unit without field-weakening control (P77 = 0). Only one measuring point is taken at EMF = 100 V; Duration, approx. 10 s Unit with field-weakening control (P77 \geq 120 V) Duration up to 2 min. The field characteristic test is realized at approx. half the EMF setpoint, however between 90 V and 200 V. Depending on the field-weakening range, speeds can occur which exceed the rated speed. Further, at rated field, a measuring point with 94% of the EMF setpoint (P77) is approached.</p>

Parameter No.	Boot value	Value range (steps)	Dim.	Function
P51				<p>Possible fault messages:</p> <p>F18: Maximum measuring point number exceeded, i.e. in spite of maximum field weakening, maximum speed cannot be reached, or set EMF setpoint too small ($0 < P77 < 120 \text{ V}$).</p> <p>F30: Characteristic fault, i.e. measuring point converted to EMF setpoints do not provide a useful characteristic (e.g. load surge during field characteristic test, analog field current controller at the limit)</p> <p>The display shows the EMF and, for each measuring point, the speed actual value for 2 seconds. Set P90 = x2 before starting the field characteristic test. P90 = x0 is automatically set (mixed field operation type) and the unit is switched-into operating status 07 after the field characteristic test has been successfully executed.</p> <p>P51 = 6: (not provided for SIMOREG)</p> <p>P51 = 10: Parameters P80 - P99 can be changed.</p> <p>P51 = 20: Standard setting for parameter setting, all P -, E- and H (U) - parameters can be changed.</p> <p>P51 = 30, 31 and 35: when using supplementary boards, e.g. Z1210.</p> <p>P51 = 99: L parameters can be changed.</p> <p>Memory contents can be read-out or memory contents can be output at the analog output.</p>



WARNING

In this setting, all parameters can be changed (ONLINE). This can cause the drive to respond in a dangerous fashion.



Thus, the following procedure is recommended:
Remove terminal blocks X1.16 to 22 before setting parameter P51 to 99 (controller enable X1.18 and "ON/STOP" X 1.17 are not energized), thus it is not possible to operate the unit online.

Set parameter P51 to 0 after setting the L parameters and before inserting the plug-in terminals.

Parameter No.	Boot value	Value range (steps)	Dim.	Function
P52 *)	A50	000 - FFF	Hex	Initial program loading, refer to Section 5.4
P53-59				Are not used for SIMOREG units.
P60,61				Are used for supplementary boards, e.g. Z1210.
P62	0	0 - 100	msec	Ramp-time for reducing gearbox wear (only effective at torque direction change)
P63 *)	0	0 - 4	Hex	Operating mode for feed forward control and current controller. P63 = 0: Feed forward control and current control are functioning (normal setting). P63 = 1: Feed forward control is enabled, current contr. is inhibited. P63 = 2: Feed forward control is enabled, current controller P-component is enabled, current controller I-component is inhibited. P63 = 3: Feed forward control and current controller are inhibited, α_w is specified. P63 = 4: Feed forward control is inhibited, current contr. is enabled.
P64	0.16	0.01 - 5.00 (0.01)		Current controller P gain.
P65	25.0	0.0 - 50.0 (0.1)	msec	Current controller integral-action time T_n . It is possible to set the integral-action time to 0 (results in P-controller characteristics).
P66	30	0 - 255		Feed forward control, R component in discontinuous operation
P67	30	0 - 255		Feed forward control, R comp. in continuous operation
P68	20	0 - 100 of I_{rated} of the unit	%	Transition from discont. to continuous armature current P66-P68 are determined at the current controller optimization run.
P69	0	0 - 1	Hex	P69 = 0: Setpoint condition Calc.EMF is taken into account w/ the feed forward control P69 = 1: (only for manual setting, potential danger of current spikes) Calculated EMF is not taken into account for the feed forward control. The tachometer interruption monitoring is not effective for P69 = 1. (however, do not use to mask out fault message F11!)

Parameter No.	Boot value	Value range (steps)	Dim.	Function
P70 *)	10.0	0.0 - 180 (0.1)	min	<p>Thermal time constant for motor I²t monitoring. Motor thermal overload protection. F13 is displayed when it responds. The monitoring can be switched-out with P70 = 0.</p> <div style="border: 1px solid black; padding: 5px; margin: 10px 0;"> <p>NOTE</p> <p>The calculated pre-loading of the motor is lost when the electronics power supply fails. An unloaded motor is taken as basis after the power supply is switched-on again.</p> </div>
P71 *)	80	0 - 100 of I _{rated} of the unit	%	Ratio between rated motor current/rated unit current
P72-75				Required when using supplementary boards, e.g. Z1210.
P76 *)	1	0 - 100 of I _{rated} of the unit field current	%	Field current setpoint for current-controlled field excitation. If the current actual value falls below the setpoint by more than 50%, fault message F14 is displayed (= minimum field current not reached). The message is only activated when the main contactor is on (terminal 17 = "H"). Set P76 = 1 when using an external field supply.
P77 *)	0	0 - 900	V	EMF setpoint (cut-out point). Start of field weakening operation (cut-out voltage) P77 = 0 means that there is no field weakening control, therefore constant field current, which can be set using P76 . The field weakening control functions above P77 = 120 V at 380 V supply voltage. The field characteristic should be tested with P51 = 5 for field weakening operation.
P78	0.50	0.0 - 10.0 (0.01)		EMF controller, P gain (for field weakening operation)
P79	1.00	0.00 - 3.00 (0.01)	sec	EMF controller, integral-action time T _n (for field weakening operation)
P80 *)	0	0 - 5	Hex	<p>Operating mode for the output relay K1 on board A2.</p> <p>P80 = 0: The relay is switched as fault signaling relay. Terminals 2 and 3 closed = fault.</p> <p>P80 = 1: The relay is switched as signaling relay $n < n_{min}$, n_{min} is specified by P21. Terminals 1 and 3 (on board A2) are closed for $n < n_{min}$.</p>

Parameter No.	Boot value	Value range (steps)	Dim.	Function
P80				<p>P80 = 2: The relay is switched as signaling relay $i < i_{min}$. i_{min} is specified by P47. For $i < i_{min}$, terminals 3 and 1 are closed (on board A2).</p> <p>P80 = 3: The relay is switched as "ready" signaling relay. Terminals 3 and 1 (on board A2) are closed in the conditions 0I, - -, I or II.</p> <p>P80 = 4: The relay is switched as "drive operational" signaling relay. The relay is energized when the drive is in the operating conditions - -, I or II. Terminals 3 and 1 (on board A2) are closed.</p> <p>P80 = 5: The relay is switched as "speed controller monitoring" signaling relay. The speed monitoring is an $n_{set} - n_{act}$ comparison directly at the speed controller input, which is effective in all operating conditions. In all other operating conditions other than - -, I or II, the comparison is with setpoint zero. Comparison threshold: P27, hysteresis: 2% of n_{max} Relay pulls in if $n_{set} = n_{act}$ (precisely: $n_{set} - n_{act} < P27$) Relay drops out, if $n_{set} \neq n_{act}$ (precisely: $n_{set} - n_{act} < P27 + 2\% \text{ of } n_{max}$) When the speed controller monitoring responds (i.e. the relay drops out), this does <u>not</u> lead to a fault message. The function is also available when using supplementary boards.</p>
P81 *)	0	0 - 2	Hex	<p>Operating mode for auto-reversing module</p> <p>P81 = 0: Auto-reversing module is functioning. Response sensitivity for the torque direction, refer to parameter P93. Standard setting for 4-quadrant units.</p> <p>P81 = 1: Torque direction T I is inhibited. If a setpoint is input, for which the torque direction is inhibited, P00 = - - is displayed.</p> <p>P81 = 2: Torque direction T II is inhibited.</p>
P82	7	0 - 17		Assignment of the selector terminal: A1, X1.14; refer to Section 4.6
P83 *)	0	0 - 14		Assignment of the selector terminal: A1, X1.19; refer to Section 4.6
P84 *)	0	0 - 14		Assignment of the selector terminal: A1, X1.20; refer to Section 4.6

Parameter No.	Boot value	Value range (steps)	Dim.	Function
P85 *)	0	0 - 11		Selector terminal assignment: A1, X1.8; refer to Section 4.6
P86 *)	0	0 - 3	Hex	Operating mode for the analog output terminal A1, X1.12; Current actual value display, refer to Section 4.6
P87	33	00 - 33	Hex	<p>Mode selection for switching-on again and for fault acknowledgement, also refer to Sections 5.4 and 7.</p> <p>P87 = x0: The fault is immediately stored and the unit switched-off at voltage failure.</p> <p><u>Fault acknowledgement:</u> The fault messages must be acknowledged before the unit is switched-on again.</p> <p>P87 = x1 At Phase failure, automatic restart is realized when the phase returns within approx. 400ms.</p> <p><u>Fault acknowledgement:</u> The fault messages must be acknowledged at the unit before switching-on again.</p> <p>P87 = x2: The fault is immediately stored and the drive shutdown at phase failure.</p> <p><u>Fault acknowledgement:</u> The equipment can be switched-on again by energizing the on/stop terminal when the following faults occur (it is not necessary to acknowledge at the unit):</p> <ul style="list-style-type: none"> F04 Phase failure, line fuse F05 Undervoltage condition F12 $i > 300\%$ current actual value $> 300\%$ of the rated current F13 $i^2 t$ - monitoring has responded F14 Minimum field current not reached F21 External pulse cancellation is input <p>Control board A2 - X1: Terminal 7 not connected to terminal 8 for 30A to 600A units A2 - X1: Terminal 16 not connected to terminal 17 for 640 A to 1200 A units</p> <p>The fault display is however retained. It must be occasionally acknowledged on the unit.</p> <p>P87 = x3: At Phase failure, automatic restart is realized when the phase returns within approx. 400ms.</p> <p><u>Fault acknowledgement:</u> As described under P87 = x2.</p>

Parameter No.	Boot value	Value range (steps)	Dim.	Function
P87				<p>P87 = 0x: Each parameter change and fault message is immediately transferred into the non-volatile memory. The parameter memory-RAM monitoring is in operation. <u>The setting 3x is recommended when terminal 17 is frequently energized (ON/STOP).</u></p> <p>P87 = 1x: Protection against subsequent parameter changes. Parameters P87 and P52 are immediately transferred into the non-volatile memory at each change, the remaining parameters are <u>not</u> stored in the EEPROM. After the supply voltage has been switched-off, the original parameters stored in the EEPROM are used. Fault message F34 ("EEPROM fault") is not effective!</p> <p>P87 = 2x: Protection against subsequent parameter changes. Only parameters P87 and P52 and fault messages are immediately transferred into the non-volatile memory at each change, the remaining parameters are not stored in the EEPROM. Fault message F34 ("EEPROM fault") is not effective!</p> <p>It is possible to change parameter contents if the EEPROM inhibit is active (P87 = 1x or 2x) and the electronics power supply is switched-on. The changes are also immediately effective. The changed parameter contents are however stored in the RAM and are lost when the electronics power supply is switched-off.</p> <p>P87 = 3x: Every parameter change and fault message is immediately transferred into the non-volatile memory. The parameter memory-RAM monitoring is operational.</p> <div data-bbox="699 1406 1449 1675" style="border: 1px solid black; padding: 5px;"> <p> WARNING</p> <p>F04 and F05 cannot always be stored when the electronics power supply fails and thus the motor can start-up again when the supply voltage returns and enable signals are available.</p> </div> <p>Further, a <u>hardware write protect</u> can be activated when the permanent memory inhibit is activated (P87 = 1x or 2x) (no further changes are stored in the EEPROM). The following measures are carried out on the A1200 electronics board. Up to version 03 or C1, ...: jumper BR 5 open-circuit From version 04 or D1, ...: plug-in jumper EA - EB - EC is brought into the EA - EB setting. The jumper must only be changed when the unit is in the <u>no-voltage condition</u> (power-off).</p>

Parameter No.	Boot value	Value range (steps)	Dim.	Function
P88 *)	1	0 - 1	Hex	<p>Select the operating mode for automatic field current reduction</p> <p>P88 = 0: The field current setpoint set at parameter P76 is not automatically reduced. Full field at standstill (value of P76).</p> <p>P88 = 1: Automatic field current reduction (standstill excitation): The excitation current is reduced to the value set at parameter P96 (% of P76) 10 seconds after the main contactor has been switched out via relay K2 of the SIMOREG unit (stop, off or fault). The field current setpoint, set at parameter P76 is automatically selected when the main contactor is again switched-in through relay K2.</p>
P89 *)	00	00 - 73	Hex	<p>Speed controller operating mode</p> <p>P89 one's digit:</p> <p>P89 = x0: The PI controller is in operation (normal setting)</p> <p>P89 = x1: Speed controller is operational, however only as P controller</p> <p>P89 = x2: The speed controller is inhibited. The current supplementary setpoint P29 is output. Speed setpoints are ineffective. (Only for service purposes)</p> <p>P89 = x3: The speed controller is inhibited. Setpoints at terminals 4 and 6 are interpreted as current setpoints. (+) = T I.</p> <p>P89 ten's digit:</p> <p>The n controller integral-action time can be multiplied by a factor when the ramp-function generator runs. This factor can be set via the ten's digit of parameter P89. The speed controller behaves like a P controller during ramp-up (speed overshoot is reduced).</p> <p>P89 = 0x: Factor 1 (i.e. function is disabled)</p> <p>P89 = 1x: Factor 3</p>

Parameter No.	Boot value	Value range (steps)	Dim.	Function
P89				<p>P89 = 2x: Factor 10</p> <p>P89 = 3x: Factor 30</p> <p>P89 = 4x: Factor 100</p> <p>P89 = 5x: Factor 300</p> <p>P89 = 6x: Factor 1000</p> <p>P89 = 7x: Factor 0 (i.e. the speed controller integrator is set to 0)</p> <p>P89 = 8x: Factor 1 (i.e. the function is disabled)</p> <p>P89 = 9x: Factor 900</p> <p>Adaption is only effective when the ramp-function generator is active (P16 ≠ 0, P17 ≠ 0) The actually effective integral-action time is internally set to a maximum of 100 sec!</p>
P90 *)	02	00 - 12	Hex	<p>Field weakening control mode. Field weakening starts at the EMF set in P77. A constant field current is output without field weakening control P77 = 0. Also refer to Section 5.8.</p> <p>P90 = x0: Normal operating mode for EMF control, field feed forward control plus EMF control (value after field characteristic test).</p> <p>P90 = x1: Speed feed-forward controlled field</p> <p>P90 = x2: EMF-controlled field</p> <p>P90 = 0x: P77 (EMF setpoint) is used as EMF setpoint in the field weakening range. Parameter E77 is ineffective.</p>

Parameter No.	Boot value	Value range (steps)	Dim.	Function
P90				<p>P90 = 1x: The maximum armature voltage is input into parameter E77. The EMF setpoint is calculated from parameter E77 (armature voltage) during the characteristic test, and is stored in parameter P77. The setting is recommended if the armature resistance R_A is not known.</p> <div style="border: 1px solid black; padding: 5px; margin: 10px 0;"> <p>NOTE</p> <p>The tachometer potentiometer and the parameter EMF_{set} (P77), V_{Arated} (E77) and $I_{field set}$ (P76) must <u>not</u> be changed after the field characteristic test.</p> </div>
P91 *)	000	000 - FFF		Masking-out fault messages, refer to Section 8.14
P92				Not used for SIMOREG units.
P93	0.10	0.00 - 10.0 of n contr. (0.01)	%	Changeover values for the auto-reversing module
P94 *)	30	0 - 180	Deg.	Gating unit, rectifier stability limit α_G
P95 *)	150	0 - 180	Deg.	Gating unit, inverter stability limit α_W
P96	0	0 - 100	%	Standstill excitation current. The set value is referred to the value set at P76.
P97				Control parameter for the serial interface, e.g. for the Z1210 supplementary board.
P98 *)	...	000- 900	V	<p>Rated unit supply voltage for the power section. Adaption factor for the armature circuit-supply voltage.</p> <p>P98 = 380 x \ddot{u}</p> $\ddot{u} = \frac{\text{Armature circuit-supply voltage}}{\text{Electronics power supply voltage}}$ <p>This means:</p> <p>a) with the same supply voltage for the armature circuit and the electronics power supply (only for 380V + 20%-15% or 415V + 10%-22% possible) then P98 = <u>380V</u> must always be entered.</p>

Parameter No.	Boot value	Value range (steps)	Dim.	Function
P98				<p>b) with different supply voltages for the armature circuit and electronics power supply (e.g. with 500 V armature supply), P98 = 380 x \ddot{u} must be entered. $1/\ddot{u}$ corresponds to the ratio of a matching transformer for the electronics power supply voltage.</p> <p>Factory setting: P98 = 380 for 6RA22...-DV... (380V units) P98 = 500 for 6RA22...-GV... (500V units)</p> <div style="border: 1px solid black; padding: 5px; margin-top: 10px;"> <p>NOTE</p> <p>The entry is mandatory for the EMF calculation. The parameter is factory set according to the rating plate, and is not changed at initial program loading. Thus, these parameters must be correctly set manually <u>before</u> each subsequent initial program loading.</p> </div>
P99 *)	...	1x.x - 3x.x	Hex	<p>Setting the unit version and software release: The software release is displayed at parameter P99. Further, at the first location (hundred's digit) the following is available):</p> <p>P99 = 1x.x: SIMOREG 1Q (6RA22xx-xxS2x)</p> <p>P99 = 2x.x: SIMOREG 4Q (6RA22xx-xxV6x)</p> <p>P99 = 3x.x: SIMODRIVE (6RA27...)</p> <p>The parameter is factory set and is not changed at initial program loading. Thus, these parameters must be correctly set manually before each subsequent initial program loading. If P99 is changed, the electronics power supply must be switched-out for at least 10 sec.</p> <p>Example: 1Q SIMOREG unit Software release 3.2</p> <p>P99 = 13.2</p>

Parameter No.	Boot value	Value-range (steps)	Dim.	Function
E00	...	000 - FFF	Hex	<p>E00 = 0: SIMOREG basic unit without additional boards.</p> <p>Basic unit is prepared for operation with supplementary boards, whereby:</p> <p>E00 = 1: SIMOREG with board A1210-L31 (Z1210).</p> <p>E00 = 2 Basic unit with spindle positioning control (supplementary board A1211 + power supply module C98130-A1070-A1, only for main spindle drives 6RA27..).</p> <p>E00 = 3 Basic unit with remote diagnostics and limit value board (supplementary board A1218).</p> <p>E00 = 4 Basic unit with MPC interface (supplementary board A1216, only for main spindle drives 6RA27..).</p> <p>E00 = 5 Freely available for subsequent applications.</p> <p>E00 = 6: Basic unit with SINEC-L1 interface board (supplementary board Z1001).</p> <p>E00 = 7: Basic unit with SINEC-L1 interface board, analog setpoint input (supplementary board Z1001).</p> <p>E00 = 8: Basic unit with supplementary board coupled through the dual-port RAM (Z1011), for transmitting a 4-word protocol.</p> <p>E00 = 9: Basic unit with supplementary board coupled through a dual-port RAM (Z1011, Z1004), for transmitting a 10-word protocol.</p> <p>E00 = A; b; C, d; E: Freely available for subsequent applications.</p> <p>E00 = F: Not for SIMOREG K units.</p>

Parameter No.	Boot value	Value range (steps)	Dim.	Function
E00				The parameter is not changed at initial program loading. Thus, these parameters must be correctly set manually <u>before</u> each subsequent initial program loading. Each digit on the 3-digit 7-segment display signifies a unit configuration according to the list above. Thus, a maximum of three different options can be combined. e.g. the supplementary boards Z1210 and A1218 are used: In parameter E00, a 1 must be set at one of the display digits (for Z1210) and a 3 (for A1218). E00 = 013 or 031 or 103 ...
E01	100	0 - 105	0.1V	System voltage speed setpoint (terminals 4 and 6) (e.g. 100% $\hat{=}$ 10V system voltage, 60% $\hat{=}$ 6V system voltage) E01 = V_e [V] x 1000 : U_A [%] V_e = input voltage V_A = output (intervention in %) E01 = 100 \rightarrow 10V $\hat{=}$ 100; E01 = 60 \rightarrow 6V $\hat{=}$ 100
E02	100	0 - 999	0.1V	System voltage for supplementary analog input (terminal 8) (e.g. 100% $\hat{=}$ 10V system voltage, 60% $\hat{=}$ 6V system voltage) E02 = V_e [V] x 1000 : U_A [%] V_e = input voltage V_A = output (intervention in %) E02 = 100 \rightarrow 10V $\hat{=}$ 100; E02 = 60 \rightarrow 6V $\hat{=}$ 100
E03 *)	10	00 - 11	Hex	Filter type selection E03 = x0 Filtering through 1st order filter. Parameter P20 can be set. E03 = x1 The speed controller input is fed through a 2nd order band-stop, which can be selected via parameters E04 to E08 (P20 is ineffective). Disabling the speed controller monitoring E03 = 0x Monitoring active E03 = 1x Monitoring disabled (error F15 masked-out)
E04	0	0 - 3		Suppression quality of the band-stop E04 = 0 Band-stop quality = 0.5 E04 = 1 Band-stop quality = 1 E04 = 2 Band-stop quality = 2

Parameter No.	Boot value	Value range (steps)	Dim.	Function
E04				E04 = 3 Band-stop quality = 3
E05	0	0 - 140	Hz	Resonance frequency of the band-stop filter (setting: 0 ... 7 → band-stop not active)
E06-08				Required when using supplementary board Z1210.
E09-15				Is not used for SIMOREG units.
E16-20				Is used for the supplementary board Z1210.
E21	120	0 - 120 of n_{max}	%	Response threshold for overspeed protection (0: overspeed protection disabled)
E22-30				Is required when using supplementary board Z1210.
E31-32				Is not used for SIMOREG units.
E33	0.0	-30 - +30 of V_{Arated} at I_{Arated} (0.1)	%	IxR compensation The factor "current actual value xE33" is taken from the signal fed in at terminal 1 or 2 (armature voltage, sensed using an external potential transformer, instead of a tachometer) (also refer to Section 8.10).
E34-38				Is not used for SIMOREG units.
E39 *)	0	0 - 3		Thyristor check E39 = 0: Thyristor check switched-out (as supplied) E39 = 1: Thyristors are checked when the unit is first switched-on (terminal x1.17 or inching) after the supply voltage has been built-up. E39 = 2: Thyristors are checked each time the unit is switched-on via terminal 17 or inching. E39 = 3: Thyristors are checked when the unit is switched-on via terminal 17 or inching. The drive continues to run and parameter E39 is automatically set to 0 if no defective thyristors have been identified. The defective thyristor or thyristor module is signaled with the fault signals F41 to F76. The test routine lasts approximately 5 seconds.
E40				Is not used for SIMOREG units.

Parameter No.	Boot value	Value range (steps)	Dim.	Function
E41	0.0	0.0 - 10.0 of n_{max} (0.1)	%	<p>Changeover threshold P/PI speed controller</p> <p>Changeover from PI speed control to P controller characteristics:</p> <p>Changeover from PI to P controller is possible via gearstage selection, when the I component of the selected speed controller is set to 0, i.e. the integral-action time of the corresponding gearstage is 0.</p> <p>In gearstage I (terminals 117, 118 and 119 not energized on the Z1210 board), a changeover is made from the PI controller to P controller, dependent on the speed actual value if a speed, set via parameter E41, is not reached (the integrator is only switched-in again at $n_{act} > E41 + 2\%$ of n_{max}). This permits jolt-free braking of the drive only through the speed setpoint ($n_{set} \rightarrow 0$), without removing the ON/STOP signal (terminal 17) (the motor still remains speed controlled).</p> <p>This function is switched-out for $E41 = 0$ (as supplied).</p>
E42-50				Is not used for SIMOREG units.
E51-59				Is required when using supplementary board Z1210.
E60	0.0	0 - 10.0 (0.1)	%	<p>Droop circuit</p> <p>Influences the speed controller. 10% droop causes the speed actual value to deviate from the setpoint by 10% of the maximum speed when loaded with the equipment rated current.</p> <div style="text-align: center;"> </div> <p>Droop function (analog equivalent circuit diagram)</p>
E61-66				Required when using the supplementary board Z1210.
E67	1.0	-9.9 - + 9.9 (0.1)		Normalization factor for analog output at terminal 14, refer to terminal strip X1.14 (Section 4.6).
E68	300	0 - 300 of $M_{Mot rated}$	%	Torque limiting (refer to Section 8.11)

Parameter No.	Boot value	Value range (steps)	Dim.	Function
E69				<p>E69 = 0: Power limiting switched-out (as supplied)</p> <p>E69 = 1 ... 300% of P_{rated}: Power limiting active $P_{rated} = I_{motor} \times EMF_{rated} = P71 \times L09$ (Note: L09 is set the same as parameter P77 during field characteristic testing, except if P77 = 0. In this case, the EMF for $n_{act} = 100\%$ is loaded in parameter L09)</p> <p>The power limiting limits the armature current so that the power limit set with parameter E69 is not exceeded. The field current setpoint is not influenced by the power limiting.</p>
E70 *)	00	00 - 11	Hex	<p>Selecting the torque closed-loop control mode</p> <p>E70 = x0: Current control</p> <p>E70 = x1: Torque control (i.e. the speed controller output is divided by the actual magnetic motor flux)</p> <p>E70 = 0x: Analog limiting via terminal X1.8 on A1200 acts as current limiting</p> <p>E70 = 1x: Analog limiting via terminal X1.8 on A1200 acts as torque limiting (if torque limiting is parametrized).</p>
E71-75				Is required when using supplementary board Z1004 and Z1011 (Z1001).
E77 *)	0	0 - 900	V	<p>Armature voltage Is used for field-weakening operation (also refer to P90).</p>
E78-79				Is not used for SIMOREG units.
E80 *)	000	000 - 142	Hex	<p>Speed controller adaption (refer to Section 8.9)</p> <p>E80 = xx0: Adaption switched-out</p> <p>E80 = xx1: SID-dependent adaption (SID = speed-setpoint actual value difference)</p> <p>E80 = xx2: Speed-dependent adaption</p>

Parameter No.	Boot value	Value range (steps)	Dim.	Function															
E80				<p>E80 = x0x: Adaption switched-out</p> <p>E80 = x1x: Adaption is effective in gearstage I</p> <p>E80 = x2x: Adaption is effective in gearstages I and II</p> <p>E80 = x3x: Adaption is effective in gearstages I, II and III</p> <p>E80 = x4x: Adaption is effective in gearstages I, II, III and IV</p> <p>E80 = 0xx: No gearstage adaption of the adaption parameters</p> <p>E80 = 1xx: Gearstage adaption of the adaption parameters E81 and E82</p> <table border="1"> <thead> <tr> <th>Stage</th> <th>I</th> <th>II</th> <th>III</th> <th>IV</th> </tr> </thead> <tbody> <tr> <td>KPN = (P gain)</td> <td>E81</td> <td>$E81 \times \frac{P33}{P31}$</td> <td>$E81 \times \frac{P35}{P31}$</td> <td>$E81 \times \frac{P37}{P31}$</td> </tr> <tr> <td>KPN = (Integral-action time)</td> <td>E82</td> <td>$E82 \times \frac{P34}{P32}$</td> <td>$E82 \times \frac{P36}{P32}$</td> <td>$E82 \times \frac{P38}{P32}$</td> </tr> </tbody> </table> <p>Gearstage changeover only possible via the supplementary board</p>	Stage	I	II	III	IV	KPN = (P gain)	E81	$E81 \times \frac{P33}{P31}$	$E81 \times \frac{P35}{P31}$	$E81 \times \frac{P37}{P31}$	KPN = (Integral-action time)	E82	$E82 \times \frac{P34}{P32}$	$E82 \times \frac{P36}{P32}$	$E82 \times \frac{P38}{P32}$
Stage	I	II	III	IV															
KPN = (P gain)	E81	$E81 \times \frac{P33}{P31}$	$E81 \times \frac{P35}{P31}$	$E81 \times \frac{P37}{P31}$															
KPN = (Integral-action time)	E82	$E82 \times \frac{P34}{P32}$	$E82 \times \frac{P36}{P32}$	$E82 \times \frac{P38}{P32}$															
E81	2.9	0.0 - 200 (0.1)		P gain for small SID / currents (P gain for SID / I > threshold 2 and n < E85)															
E82	0.62	0.00 - 10.00 (0.01)	sec	Integral-action time for small SID / currents (P gain for SID / I > threshold 2 and n < E85)															
E83	0.0	0.0 - 100 (0.1)	%	SID / current - threshold 1 (current or setpoint-actual value difference)															
E84	0.0	0.0 - 100 (0.1)	%	SID / current - threshold 2 (current or setpoint-actual value difference)															
E85	0.0	0.0 - 100 of n _{max} (0.1)	%	Speed limit for the adaption range (adaption is ineffective above this speed; transition range from E85 to E85 + 5% of n _{max})															
E86				Required when using supplementary boards Z1210, Z1004 and Z1011 (Z1001).															

*) L signal (open-circuit < 4.5 V) must be available at terminal 17 or 18 (controller inhibit) to change the parameter contents

If 99 is set at key parameter P51, the L parameters appear after the last H/U parameters. Values stored in the EEPROM can be read-out using these parameters and also changed, which are normally only internally used, or written into during the field characteristic test (L08 - L34).



WARNING

In this setting, all parameters can be changed during online operation. This can lead to the drive responding in a dangerous fashion.



Thus, the following procedure is recommended:

Remove terminal blocks X1.16 to 22 before setting parameter P51 to 99 (controller enable X1.18 and ON "STOP" X1.17 are not energized), thus online unit operation is not possible.

Set parameter P51 to 0 after setting the L parameters and before inserting the plug-in terminals.

Parameter No.	Boot value	Value range (steps)	Dim.	Function
A-L	00	00 - FF	Hex	Diagnostic address, low byte
A-H	10	00 - FF	Hex	Diagnostic address, high byte
≡ -- ≡		00 - FF	Hex	Contents of the diagnostic memory location
SHI	0	1 - 15		No. of shifts for analog diagnostic function
L04	01	00 - FF	Hex	Various flag bits
L05	00	00 - 99	Hex	Last fault
L06	0.0	-105 - +105 (0.1)	%	Ramp-function generator output for the motorized pot. (in conjunction with supp. boards Z1210, Z1004, Z1011)
L07		0 - 999 (0.01)		EMF / n_{act} normalized
L08	0	0 - 1	Hex	"Field characteristic tested" flag (also refer to Section 5.8)
L09	340	0 - 999	V	EMF setpoint at the cut-out speed
L10	100	0 - 199 of n_{max} (0.1)	%	Cut-out speed for field weakening
L11	199	0 - 199 of n_{max} (0.1)	%	1st characteristic point for the field characteristic
L12	199	0 - 199 of n_{max} (0.1)	%	2nd characteristic point
L13	199	0 - 199 of n_{max} (0.1)	%	3rd characteristic point
L14	199	0 - 199 of n_{max} (0.1)	%	4th characteristic point

Parameter No.	Boot value	Value range (steps)	Dim.	Function
L15	199	0 - 199 of n_{max} (0.1)	%	5th characteristic point
L16	199	0 - 199 of n_{max} (0.1)	%	6th characteristic point
L17	199	0 - 199 of n_{max} (0.1)	%	7th characteristic point
L18	199	0 - 199 of n_{max} (0.1)	%	8th characteristic point
L19	199	0 - 199 of n_{max} (0.1)	%	9th characteristic point
L20	199	0 - 199 of n_{max} (0.1)	%	10th characteristic point
L21	199	0 - 199 of n_{max} (0.1)	%	11th characteristic point
L22	199	0 - 199 of n_{max} (0.1)	%	12th characteristic point
L23	199	0 - 199 of n_{max} (0.1)	%	13th characteristic point
L24	199	0 - 199 of n_{max} (0.1)	%	14th characteristic point
L25	199	0 - 199 of n_{max} (0.1)	%	15th characteristic point
L26	199	0 - 199 of n_{max} (0.1)	%	16th characteristic point
L27	199	0 - 199 of n_{max} (0.1)	%	17th characteristic point
L28	199	0 - 199 of n_{max} (0.1)	%	18th characteristic point
L29	199	0 - 199 of n_{max} (0.1)	%	19th characteristic point
L30	199	0 - 199 of n_{max} (0.1)	%	20th characteristic point
L31	0	0 - 40		2x the number of valid characteristic points
L32	13	0 - 255		Min. field current at n_{max} [255 = rated field current (P76)]
L33	00	00 - 33		Supply frequency correction/response threshold F11
L34	0	-199 - + 199	10 μ s	Offset to the supply voltage zero crossover

10. Service instructions



WARNING

This unit contains hazardous voltages.

Dangerous voltages can be present on the customer side at signaling relays K1, K2 and K4 . . . K7.

Loss of life, severe bodily injury or property damage can result if this equipment is incorrectly handled.

Please observe the maintenance measures relevant for this unit specified in this section and the instructions listed on the unit itself.



- Only qualified personnel should work on this equipment, and only after becoming familiar with all safety notices, installation, operation and maintenance procedures contained in this manual.
- Before carrying visual inspections and service work, it should be ensured that the AC feeder is disconnected and locked out and that the unit is grounded. Both the converter and the motor have hazardous voltage levels before the AC power supply is disconnected. Even with the converter contact is opened, hazardous voltages are available.
- Only spare parts authorized by the manufacturer must be used.

The converter should be kept clean and clear of any contamination, in order to prevent voltage arcing and thus destruction. Dust and foreign objects which enter the unit through the cooling air current should be regularly removed but at least once every 12 months. The unit should be cleaned using dry compressed air having a maximum pressure of 1 bar, or with a vacuum cleaner.

11. Spare parts

Spare parts can be taken from Catalog DA 21 E.

NOTE

If questions arise please be ready to specify the following equipment data:

- Equipment Order No. and Serial No.
- Software release
- Hardware version of the basic electronics board (printed on the component side)
- Hardware version and software release of supplementary boards (if available)

12. Start-up log

Machine	Type : Serial No. :	Startup, service on: from: Notes:																
Motor	Type : Rated armature current: Rated field current: Maximum armature voltage: Maximum speed:	Notes: on: from: Notes:																
Tachometer	Type : Volt / 1000 RPM	Notes:																
SIMOREG unit	Type : D / Mreq - GdG V6 Serial No. : Unit maximum current in the armature circuit: Reduced to using burden adaption: Unit max. current, field circuit: Reduced to using burden adaption:	on: from: Notes:																
Potentiometer settings made at start-up: <table border="1" style="margin-left: 20px;"> <tr> <td style="text-align: center;">R1</td> <td></td> <td></td> <td style="text-align: center;">R2</td> </tr> <tr> <td style="text-align: center;">R3</td> <td></td> <td></td> <td style="text-align: center;">R4</td> </tr> </table> <table border="1" style="margin-left: 20px;"> <tr> <td style="text-align: center;">n_{act} coarse</td> <td></td> <td></td> <td style="text-align: center;">n_{act} fine</td> </tr> <tr> <td style="text-align: center;">n_{act} display</td> <td></td> <td></td> <td style="text-align: center;">l_{act} external</td> </tr> </table>			R1			R2	R3			R4	n_{act} coarse			n_{act} fine	n_{act} display			l_{act} external
R1			R2															
R3			R4															
n_{act} coarse			n_{act} fine															
n_{act} display			l_{act} external															

Parameters changed during start-up:

	Boot value	Changed param.		Boot value	Changed param.		Boot value	Changed param.
P11	2.0		P80	0		E80	000	
P12	-2.0		P81	0		E81	2.9	
P13	2.0		P82	7		E82	0.62	
P14	001		P83	0		E83	0.0	
P16	0.00		P84	0		E84	0.0	
P17	0.00		P85	0		E85	0.0	
P18	0.00		P86	0		Field characteristic		
P19	0.00		P87	33		L08	0	
P20	3		P88	1		L09	340	
P21	0.5		P89	00		L10	100	
P27	2.0		P90	02		L11	199	
P28	0		P91	000		L12	199	
P29	0		P93	0.10		L13	199	
P30	0		P94	30		L14	199	
P31	2.9		P95	150		L15	199	
P32	0.62		P96	0		L16	199	
P39	100		P97	019		L17	199	
P40	100		P98	...		L18	199	
P41	100		P99	...		L19	199	
P42	100		E00	...		L20	199	
P43	0.5		E01	100		L21	199	
P48	100		E02	100		L22	199	
P49	100		E03	10		L23	199	
P50	0		E04	0		L24	199	
P51	0		E05	0		L25	199	
P52	A50		E21	120		L26	199	
P62	0		E33	0.0		L17	199	
P63	0		E39	0		L28	199	
P64	0.16		E41	0.0		L29	199	
P65	25.0		E60	0.0		L30	199	
P66	30		E67	1.0		L31	0	
P67	30		E68	300		L32	13	
P68	20		E69	0		L33	00	
P69	0		E70	00		L34	0	
P70	10.0		E71	000				
P71	80		E72	0				
P76	1		E73	0				
P77	0		E74	0				
P78	0.50		E75	00				
P79	1.00		E77	0				

13. Additional documentation

Circuit manuals for 600A units:	Order No.: C98130-A1072-A1-*-22
Circuit manual for units > 600A:	Order No.: C98130-A1075-A1-*-22
Application (EMC):	Order No.: C98130-A1072-A2-*-7635
Operating instructions for supp. board Z1210:	Order No.: C98043-A1210-L31-*-7619
Circuit diagram, supplementary board Z1210:	Order No.: C98043-A1210-L31-*-11
Catalog DA21	Converters
Catalog DA21E	Spare parts
Catalog DA22	Cubicle units

EG-Herstellererklärung

(nach Art. 4 Abs. 2 der EG-Richtlinie 89/392/EWG MSR)

C98130-A1072-A1-01-K6

Hersteller: Siemens Aktiengesellschaft Österreich
Gerätewerk Wien

Anschrift: Siemensstraße 88-92
A-1210 Wien

Produktbezeichnung: SIMOREG K
Stromrichtergerät mit Mikroprozessor
6RA22...-.....-.....

Das bezeichnete Produkt ist ausschließlich zum Einbau in eine andere Maschine bestimmt. Die Inbetriebnahme ist solange untersagt, bis die Konformität des Endproduktes mit der Richtlinie 89/392/EWG des Rates, festgestellt ist.

Wir bestätigen die Konformität des oben bezeichneten Produktes mit den Normen:

EN 60204-1 (DIN EN 60204 Teil 1 / VDE 0113 Teil 1)

VDE 0160

VDE 0558 Teil1

Wien, den 15. 02. 1995

Siemens Aktiengesellschaft

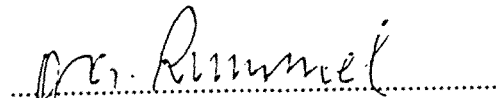

Rummel, GWW-SR

Leiter der Produktionseinheit Stromrichtergeräte



Groß, GWW-SRL

Leiter der Logistik Stromrichtergeräte

Diese Erklärung ist keine Zusicherung von Eigenschaften.

Die Sicherheitshinweise der mitgelieferten Produktdokumentation sind zu beachten.



Issued by:
Gerätewerk Wien
Postfach 83, A-1211 Wien

**System-based
Drive Technology**

Siemens Aktiengesellschaft

© Siemens AG 1989
Subject to change without notice

Order No.: C98130-A1072-A1-09-7619
Printed in Austria