

SIEMENS

SIMATIC

TeleService V6.1 Service Software for SIMATIC S7 and C7

Manual

Preface	
Contents	
<hr/>	
Introducing TeleService	1
<hr/>	
Installing Software and Hardware	2
<hr/>	
Basic Information about TeleService	3
<hr/>	
Setting the Parameters for TeleService	4
<hr/>	
Configuring the TS Adapter I/II	5
<hr/>	
Configuring the TS Adapter IE	6
<hr/>	
Accessing Remote Plants (Remote Maintenance)	7
<hr/>	
Establishing Connections from Remote Plants (PG-AS Remote Connection)	8
<hr/>	
Data Communication between Remote Plants (AS-AS Remote Connection)	9
<hr/>	
Sending Messages from a Plant (Sending SMS)	10
<hr/>	
Sending E-mail	11
<hr/>	
Managing Plant Data in Phone Books	12
<hr/>	
Troubleshooting	13
<hr/>	
Glossary	
Index	

Safety Guidelines

This manual contains notices you have to observe in order to ensure your personal safety, as well as to prevent damage to property. The notices referring to your personal safety are highlighted in the manual by a safety alert symbol, notices referring to property damage only have no safety alert symbol. The notices shown below are graded according to the degree of danger.



Danger

indicates that death or severe personal injury **will** result if proper precautions are not taken.



Warning

indicates that death or severe personal injury **may** result if proper precautions are not taken.



Caution

with a safety alert symbol indicates that minor personal injury can result if proper precautions are not taken.

Caution

without a safety alert symbol indicates that property damage can result if proper precautions are not taken.

Notice

indicates that an unintended result or situation can occur if the corresponding notice is not taken into account.

If more than one degree of danger is present, the warning notice representing the highest degree of danger will be used. A notice warning of injury to persons with a safety alert symbol may also include a warning relating to property damage.

Qualified Personnel

The device/system may only be set up and used in conjunction with this documentation. Commissioning and operation of a device/system may only be performed by **qualified personnel**. Within the context of the safety notices in this documentation qualified persons are defined as persons who are authorized to commission, ground and label devices, systems and circuits in accordance with established safety practices and standards.

Prescribed Usage

Note the following:



Warning

This device and its components may only be used for the applications described in the catalog or the technical description, and only in connection with devices or components from other manufacturers which have been approved or recommended by Siemens.

Correct, reliable operation of the product requires proper transport, storage, positioning and assembly as well as careful operation and maintenance.

Trademarks

All names identified by ® are registered trademarks of the Siemens AG.

The remaining trademarks in this publication may be trademarks whose use by third parties for their own purposes could violate the rights of the owner.

Disclaimer of Liability

We have reviewed the contents of this publication to ensure consistency with the hardware and software described. Since variance cannot be precluded entirely, we cannot guarantee full consistency. However, the information in this publication is reviewed regularly and any necessary corrections are included in subsequent editions.

Preface

Purpose of the Manual

This electronic manual provides you with a comprehensive overview of working with SIMATIC TeleService V6.1. It supports you in installing and commissioning the software, as well as establishing a remote link with TeleService.

This manual is intended for plant programmers and service personnel.

Required Knowledge

Readers are assumed to have general knowledge in the field of automation engineering.

It is also assumed that readers have experience working with computers or devices similar to PCs (such as programming devices) under the operating systems MS Windows 2000, MS Windows XP Home, MS Windows XP Professional or Windows Server 2003 Standard Edition.

Validity of the Manual

This manual is valid for the TeleService V6.1 software package.

Online Documentation for the TeleService V6.1

The following table provides an overview of the online documentation for TeleService V6.1:

Electronic manual (PDF)	Purpose	Order number
TeleService V6.1: Service software for SIMATIC S7 and C7.	Provides basic information for technical personnel and describes how to work with TeleService V6.1.	A5E00921336-01

Online help	Purpose	Order number
Help on TeleService V6.1: Service software for SIMATIC S7 and C7	Provides basic information for technical personnel and describes how to work with TeleService V6.1 in the form of online help.	Part of the TeleService V6.1 software package
Help on TeleService V6.1: Remote maintenance of an automation system	Provides reference information on the context-sensitive dialogs as well as for menu commands, keyboard commands and the user interface of TeleService V6.1.	Part of the TeleService V6.1 software package

Calling up the Help Functions

You can open the online help for a selected object by pressing F1. From there you can use the "Contents" or "Search" tabs to search for help topics related to the active software (a dialog box, for example). This way you obtain exactly the information that is relevant to the process at hand.

Menu Commands in the Help Menu

The online help offers you information on topics you require at a specific location. You can look up specific information quickly, without having to search through a manual. In the online help you can find:

- **Help topics:** offers different ways of accessing help topic information.
- **Context-sensitive help** (F1 key): displays information on the selected object, active dialog box or window.
- **Introduction:** provides an overview of working with TeleService
- **Getting Started:** enables you to quickly familiarize yourself with TeleService
- **Using Help:** provides detailed instructions for using the online help.
- **Info:** provides information on the current version of the application.

The Context-sensitive Help

- This offers information on the current context, an open dialog box or an active window, for example. You can "Help" button or the F1 key to open the help.

- The status bar offers another form of context-sensitive help. Placing the mouse pointer over a menu command displays a brief explanation for it.
- A brief explanation is also displayed for the icons in the toolbar when you place the mouse pointer on them.

Additional Support

If you have question about using the products described in this manual that are not answered here, contact your local Siemens representative or agent responsible.

You can find a contact under:

<http://www.siemens.com/automation/partner>

You will find a guide to the technical documentation offered for the individual SIMATIC Products and Systems here at:

<http://www.siemens.de/simatic-tech-doku-portal>

The online catalog and order system are available at:

<http://mall.automation.siemens.com/>

Training Center

Siemens offers a number of training courses to familiarize you with the SIMATIC S7 automation system. Please contact your regional training center or our central training center in D 90327 Nuremberg, Germany for details:

Tel.: +49 (911) 895-3200.

Internet: <http://www.sitrain.com>

Technical Support

You can reach the Technical Support for all A&D products

- Using the Web formula for the Support Request
<http://www.siemens.de/automation/support-request>
- Tel. + 49 180 5050 222
- Fax: + 49 180 5050 223

Service & Support in the Internet

In addition to our documentation, we offer our know-how online in the internet at:

<http://www.siemens.com/automation/service&support>

There you will find:

- The newsletter, which continually provides you with up-to-date information on your products.
- The right documents via our Search function in Service & Support.
- A forum, where users and experts from all over the world exchange their experiences.
- Your local representative for Automation & Drives.
- Information on field service, repairs, spare parts. Much more is available under "Services".

Contents

1	Introducing TeleService	1-1
1.1	Introduction to Teleservice	1-1
1.2	Functionality of TeleService and Required Components	1-2
1.3	What's New in TeleService V6.1?	1-4
1.4	Compatibility of TeleService V6.1 with the TS Adapter I/II	1-5
1.5	Phone Books, Folders and Plants in TeleService	1-6
1.6	Getting Started with TeleService	1-7
1.7	Working with a TS Adapter I/II	1-7
1.8	Working with a TS Adapter IE	1-9
2	Installing Software and Hardware	2-1
2.1	Installing TeleService.....	2-1
2.2	Usage Rights through the Automation License Manager.....	2-3
2.3	Installing the Automation License Manager.....	2-6
2.4	Rules for Handling License Keys.....	2-7
2.5	Installing the Software for the TS Adapter.....	2-7
2.6	Installing the TS Adapter and TS Adapter IE Interfaces.....	2-8
2.7	Installing a Local Modem under Windows.....	2-9
2.8	Connecting and Configuring the Remote Modem	2-10
3	Basic Information about TeleService	3-1
3.1	Calling from TeleService.....	3-1
3.2	The User Interface of TeleService.....	3-2
3.3	Phone Networks, Modems and Data Throughput	3-4
3.4	How the TS Adapter I/II Works	3-6
3.5	How the TS Adapter IE Works.....	3-6
3.6	Using the TS Adapter for TeleService	3-7
3.7	Operating the TS Adapter with a Direct Connection	3-10
3.8	Operating the TS Adapter with a Modem Connection.....	3-12
3.9	Useful Information on Access Protection for the TS Adapter I/II	3-15
3.10	Useful Information on Callback.....	3-17
3.11	Useful Information on TeleService Logbook	3-18
3.12	Information Functions in TeleService	3-19
4	Setting the Parameters for TeleService	4-1
4.1	Overview of Local and Remote Settings	4-1
4.2	Setting the PG/PC Interface	4-3
4.3	Local Settings at the PG/PC End	4-4
4.3.1	Local Parameters in TeleService.....	4-4
4.3.2	Useful Information on Setting Modem Properties.....	4-4
4.3.3	Setting the General Modem Properties	4-6
4.3.4	Setting the TeleService-Specific Modem Properties	4-6
4.3.5	Defining the Location and the Corresponding Dial Parameters	4-7

5	Configuring the TS Adapter I/II	5-1
5.1	Useful Information on Configuring the TS Adapter I/II.....	5-1
5.2	Overview of the Configuration Options for the TS Adapter I/II	5-1
5.3	Procedure for Configuring the TS Adapter I/II	5-2
5.4	Switching between Direct and Modem Connections with the TS Adapter I/II ..	5-2
5.5	Setting Up Access Protection for TS Adapter I/II	5-3
5.6	Exporting Adapter Parameters for TS Adapter I/II.....	5-3
5.7	Importing Adapter Parameters for TS Adapter I/II.....	5-4
5.8	Restoring the Default Configuration of a TS Adapter I/II	5-4
5.9	Modem Initialization String for the TS Adapter I/II.....	5-5
5.9.1	Properties of the Modem Initialization String for the TS Adapter I/II	5-5
5.9.2	Preset Modem Initialization String for the TS Adapter I/II	5-5
5.9.3	Initialization after Return of Power for the TS Adapter I/II	5-6
6	Configuring the TS Adapter IE	6-1
6.1	Procedure for Configuring the TS Adapter IE.....	6-1
6.2	Assigning IP Parameters of the TS Adapter IE	6-1
6.3	Setting the Interface for a Directly Connected TS Adapter IE	6-2
7	Accessing Remote Plants (Remote Maintenance)	7-1
7.1	Establishing a Remote Connection	7-1
7.2	Using the Remote Connection with STEP 7.....	7-2
7.3	Using the Remote Connection with Micro/WIN	7-3
7.4	Displaying the Properties of a Remote Connection.....	7-4
7.5	Disconnecting a Remote Connection	7-4
7.6	Checklist for Troubleshooting the Modem.....	7-5
8	Establishing Connections from Remote Plants (PG-AS Remote Connection)	8-1
8.1	Accessing Programming Devices/Personal Computers from Remote Plants..	8-1
8.2	Requirements for Establishing a Connection	8-2
9	Data Communication between Remote Plants (AS-AS Remote Connection)	9-1
9.1	Overview of AS-AS Remote Link.....	9-1
9.2	Hardware and Software Requirements for AS-AS Remote Link.....	9-3
10	Sending Messages from a Plant (Sending SMS)	10-1
10.1	Requirements for Sending an SMS	10-1
11	Sending E-mail	11-1
11.1	Requirements for Sending E-mail.....	11-1

12	Managing Plant Data in Phone Books	12-1
12.1	Creating and Managing Phone Books.....	12-1
12.1.1	Creating Phone Books.....	12-1
12.1.2	Opening Phone Books.....	12-2
12.1.3	Saving Phone Books.....	12-2
12.1.4	Specifying the Page Format for Printing.....	12-3
12.1.5	Displaying the Print Preview.....	12-3
12.1.6	Printing Phone Books.....	12-4
12.2	Creating and Editing Folders.....	12-5
12.2.1	Creating Folders.....	12-5
12.2.2	Cutting Folders.....	12-5
12.2.3	Copying Folders.....	12-5
12.2.4	Pasting Folders.....	12-6
12.2.5	Renaming Folders.....	12-6
12.2.6	Deleting Folders.....	12-6
12.2.7	Printing Folders.....	12-7
12.3	Creating and Editing Plants.....	12-8
12.3.1	Creating Plants.....	12-8
12.3.2	Changing Plant Data.....	12-8
12.3.3	Cutting Plants.....	12-9
12.3.4	Copying Plants.....	12-9
12.3.5	Pasting Plants.....	12-9
12.3.6	Deleting Plants.....	12-10
12.3.7	Printing Plants.....	12-10
13	Troubleshooting	13-1
13.1	General Information on Troubleshooting.....	13-1
13.2	Recording a Log File.....	13-2
13.3	Remote Connection to the TS Adapter is not Established.....	13-3
13.4	Remote Connection from the TS Adapter is not Established.....	13-5
13.5	Modem Connection is Interrupted.....	13-6
13.6	Modem Messages.....	13-7
Glossary		Glossary-1
Index		Index-1

1 Introducing TeleService

1.1 Introduction to Teleservice

SIMATIC TeleService gives your controller telecommunications capability. You can centrally manage, control, and monitor distributed plants by means of remote connections.

TeleService allows you to use the functional scope of STEP 7, STEP 7 Micro/WIN and STEP 7 Lite via a phone network which is otherwise available via the PC Adapter. This means that you can easily reach remote sections of plants and include them in the overall system.

This provides the following advantages:

- You can provide fast service if faults occur in a plant.
- You can employ your resources effectively.
- Costs are reduced considerably.
- Down times are considerably shortened.

The plant becomes much more economical.

1.2 Functionality of TeleService and Required Components

TeleService offers the following functionality:

1. Access to remote plants (teleservice):
You can centrally manage, control, and monitor distributed plants by means of remote connections.
Possible with: S7-200, S7-300, S7-400 and C7 as well as TS Adapter I/II or TS Adapter IE.
2. Establishing connections from and to remote plants (PG-AS remote link):
You can use PRODAVE MPI V5.0 and higher to establish a remote connection to a remote plant and the FB 46 "PG_DIAL" function block to establish a remote connection from a remote plant.
Possible with: S7-400, C7 and TS Adapter I/II.
3. Data exchange between plants (AS-AS remote link):
The FB 47 "AS_DIAL" function block allows two SIMATIC automation systems to exchange process data via the phone network.
Possible with: S7-200 (restricted), S7-400, C7 and TS Adapter I/II.
4. Sending an SMS from a plant:
Using the function block FB 48 "SMS_SEND", a SIMATIC automation system can send a message (SMS) via a GSM radio modem.
Possible with: S7-300, S7-400, C7 and TS Adapter I/II.
5. Sending e-mail from a plant
Using the function block FB 49 "AS_MAIL", a SIMATIC automation system can send e-mail.
Possible with: S7-300, S7-400 and TS Adapter IE.

TS Adapter Library

The independent TeleService S7 Library setup make available the function blocks FB 46 "PG_DIAL", FB 47 "AS_DIAL", FB 48 "SMS_SEND" and FB 49 "AS_MAIL" as well as examples for S7-300, S7-400 and C7.

The TeleService S7 Library integrates itself in an existing STEP 7 installation. The installation requires STEP 7 V5.0 or higher.

You can only use the function blocks in combination with the employed TS Adapter:

- for TS Adapter I/II:
FB 46 "PG_DIAL", FB 47 "AS_DIAL" and FB 48 "SMS_SEND"
- for TS Adapter IE:
FB 49 "AS_MAIL"

The following components are required so that you can use the TeleService functionality for teleservicing:

- SIMATIC TeleService and the following extra components that are not included in the optional package:
- A TS Adapter IE, TS Adapter II or TS Adapter I and an external modem on the automation system side
- An analog modem or ISDN adapter or radio modem for the GSM network on the programming device/PC side.

You require the following additional components for a PG-AS remote link:

- The PRODAVE MPI V5.0 (or later) product
PRODAVE MPI is a toolbox for the process data traffic between a programming device/PC and SIMATIC S7/C7. It handles the data traffic autonomously over the MPI interface.
- The supplied FB 46 "PG_DIAL" function block from the TeleService S7 Library

You require the following additional components for an AS-AS remote link:

- A second TS Adapter II, or a TS Adapter I and an external modem
- If appropriate, a further modem with cable
- The supplied FB 47 "AS_DIAL" function block from the TeleService S7 Library

You require the following additional components when sending an SMS:

- A radio modem for the GSM network
- An analog modem or ISDN adapter or radio modem for the GSM network on the programming device/PC side.

You require the following additional components when sending e-mail:

- The supplied FB 49 "AS_MAIL" function block from the TeleService S7 Library

1.3 What's New in TeleService V6.1?

Version 6.1 includes the following additional features or modifications compared with the previous version V6.0.

- **Operating system:**
TeleService V 6.1 runs under the operating systems MS Windows 2000, MS Windows XP Home, MS Windows XP Professional and MS Windows Server 2003 Standard Edition.
- **Improved phone book in a new format:**
TeleService V6.1 uses new phone books, which have been improved with additional optional entries for user names and passwords. Old phone books can be converted to the new format.
- **Multiuser phone books:**
As of TeleService V6.1, multiple users can use the phone book simultaneously.
- **Support for UNICODE:**
As of TeleService V6.1, you can use non-ASCII characters, for example traditional Chinese or Cyrillic in the phone book.
- **New TS Adapter for Industrial Ethernet:**
The new TS Adapter IE is being brought onto the market at the same time as TeleService V6.1.
The TS Adapter IE has the following features:
 - Integrated modem (analog or ISDN) but external modem can nevertheless be connected over RS-232 interface.
 - External 24 V power supply
 - New housing for 300 series standard rail or top-hat rail mounting
 - Industrial Ethernet interface with 10/100 Mbps and autosensing.
- **Saving of logon data:**
As of TeleService V6.1, logon data for the TS Adapter (user name and password) can be optionally saved for logging on.
- **TeleService logbook:**
As of V6.1, TeleService records all remote connections in a logbook located in the TeleService installation directory.

1.4 Compatibility of TeleService V6.1 with the TS Adapter I/II

The TeleService software has the following compatibility of the interaction between TeleService V6.1 and a TS Adapter I/II:

The version of the specific TS Adapter I/II decides the functionality, for example:

- TeleService V6.1 and TS Adapter I V3.0 (achieves V3.0 functionality)
- TeleService V6.1 and TS Adapter II V1.0 (achieves TS Adapter II V1.0 functionality)
- TeleService V6.1 and TS Adapter I V5.2 (achieves V5.2 functionality)

The operation and the configuration of the TS Adapter V3.0 with TeleService V6.0 is therefore limited to the functionality of TS Adapter V3.0.

Note

If, for example, TeleService V6.1 is used to set up the access protection in a TS Adapter I V5.x, it is no longer possible to access this TS Adapter with TeleService V3.0.

1.5 Phone Books, Folders and Plants in TeleService

In TeleService phone books, folders and plants are used to manage data for establishing remote connections to various users.

These management objects are also required if you only operate a connection to one plant. The following figure shows the main window of TeleService.

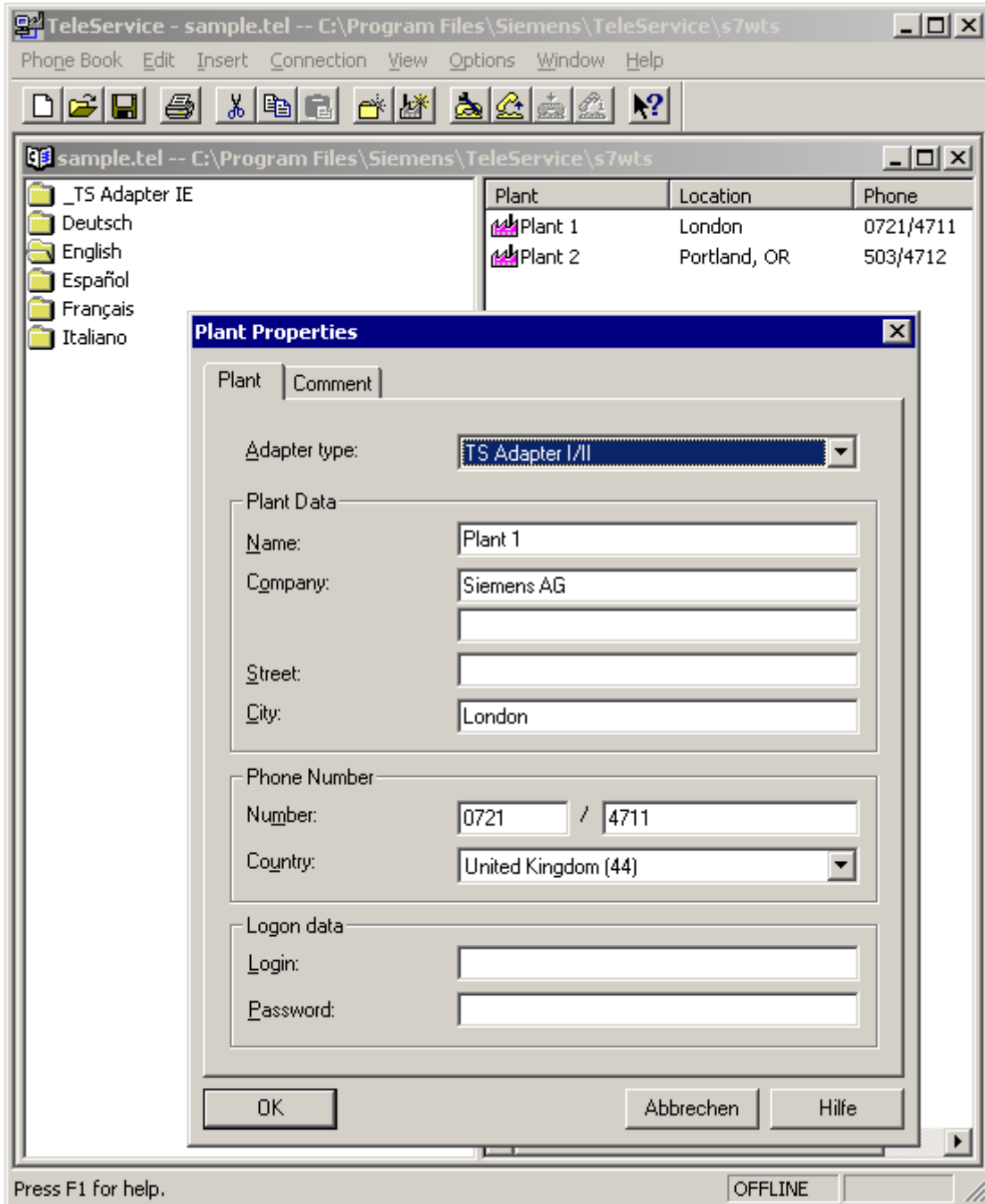

Hierarchical structuring

Phone books are the highest hierarchic level. When you create a phone book in TeleService, you can it in any directory. From there you can call it up again in order to edit it.

Phone books can contain any number of **folders** in a flat hierarchy, meaning that there are no further subfolders. Folders are used to structure the plant data. Various functions for editing folders can be accessed via the menu commands or via the right-hand mouse button.

You can create any number of **plants** in a folder. Plants contains the data which are required to establish a connection, for example the name of the user and the phone number to be dialed. As for folders plants can be edited via various menu commands and via the right-hand mouse button.

1.6 Getting Started with TeleService

Before you can establish a remote connection with TeleService, you should first become familiar with the use of the TS Adapter for TeleService. TeleService can establish remote connections to a plant using a TS Adapter I/II or a TS Adapter IE.

1.7 Working with a TS Adapter I/II

The description of how to work with TeleService and a TS Adapter I or II is divided into the following tasks:

Proceed as follows to set up the local modem:

1. Install a modem or ISDN-TA under Windows.
2. Check the Windows-specific properties of this modem. To do this, open the "Telephone and Modem Options" in the Control Panel and open the dialog with the properties of your modem.
3. Check the Windows-specific properties of the ISDN-TA. To do this, open the Windows Device Manager and find the network adapter. Then open the dialog with the properties of your ISDN-TA.
4. Open the "Set PG/PC Interface" dialog box from the "Options" menu or from the Control Panel.
5. Setting the TeleService-specific modem properties. To do this, select the interface "**TS Adapter**" in "Set PG/PC Interface" and click "Properties". Then switch to the "Local Modem" tab. There, select your modem and check the corresponding TeleService-specific properties. Define the location and the corresponding dialing parameters.

Working with a direct connection:

1. Start "Set PG/PC Interface" from the Control Panel and set the "TS Adapter" interface for a direct connection.
2. Set the parameters for the TS Adapter for a direct connection. To do this, select the menu command **Options > Assign TS Adapter I/II Parameters**. You can also export, import and reset the parameter settings of a TS Adapter I/II as well as set up access protection for the adapter parameter assignment and for the remote plant.
3. In the "Set PG/PC Interface" dialog box, set the access point of your SIMATIC application (for example, "S7ONLINE (STEP 7)" to the **"TS Adapter"** interface.
4. You can now start the SIMATIC Manager and establish a connection to the connected automation system via the TS Adapter.

Working with a modem connection:

1. Start "Set PG/PC Interface" from the "Option" menu and set the "TS Adapter" interface to modem connection.
2. In the "Set PG/PC Interface" dialog box, set the access point of your SIMATIC application (for example, "S7ONLINE (STEP 7)" to the **"TS Adapter"** interface.
3. Create phone books, folders and plants in TeleService. In plants you save the data which are required to establish a remote connection.
4. Establish the remote connection to the desired plant using the **Connection > Establish** menu command or by double-clicking on a plant.
5. After the remote connection has been established, you can switch to your SIMATIC application and access the report plant as with a direct connection. You can also display the properties of the active remote connection.
6. Disconnect the remote connection after you have completed your work.

1.8 Working with a TS Adapter IE

The description of how to work with TeleService and a TS Adapter IE is divided into the following tasks:

Proceed as follows to set up the local modem:

1. Install a modem or ISDN-TA under Windows.
2. Check the Windows-specific properties of this modem. To do this, open the "Telephone and Modem Options" in the Control Panel and open the dialog with the properties of your modem.
3. Check the Windows-specific properties of the ISDN-TA. To do this, open the Windows Device Manager and find the "Network Adapter" device class. Then open the dialog with the properties of your ISDN-TA.
4. Call "Set PG/PC Interface" from the "Options" menu or from the Control Panel.
5. Setting the TeleService-specific modem properties. To do this, select the interface "TS Adapter IE" in "Set PG/PC Interface" and click "Properties". Then switch to the "Local Modem" tab. There, select your modem and check the corresponding TeleService-specific properties. Define the location and the corresponding dialing parameters.

Working with the direct connection:

1. Set the IP parameters for the TS Adapter IE. To do this, use the menu command **Options > Assign TS Adapter IE IP Parameters**.
2. Assign the TS Adapter parameters with the direct connection. To do this, use the menu command **Options > Administer TS Adapter IE**.

Working with the modem connection:

1. In the "Set PG/PC Interface" dialog box, set the access point of your SIMATIC application (for example "S7ONLINE (STEP 7)") to the "TS Adapter IE" interface.
2. In TeleService, create phone books, folders and plants. In the plants you can store the data required for establishing a remote connection.
3. Use the menu command **Connection > Establish** or double-click on a plant to make a remote connection to the desired plant.
4. Once the remote connection is established, you can switch to your SIMATIC application and access the remote plant as with a direct connection. You can also display the properties of the active remote connection.
5. Disconnect the remote connection when you have finished your work.

2 Installing Software and Hardware

2.1 Installing TeleService

System Environment

SIMATIC TeleService V6.1 can be operated on a PG/PC with:

- The MS Windows 2000, MS Windows XP Home, MS Windows XP Professional and Windows Server 2003 Standard Edition operating systems.

Note

You can work with TeleService under user rights.
You still need administrator rights to install TeleService

Scope of the Installation

When you install TeleService V 6.1, you have the entire functionality of the TeleService software available.

Installing the Windows Multilingual User Interface Pack (MUI)

The Multilingual User Interface Pack (MUI) may need to be installed in order for Windows to correctly display foreign-language characters. The MUI is a package of language-specific files for the English version of Microsoft Windows Professional, that enables the correct display foreign-language characters.

Starting the Installation Program

TeleService contains a setup program which carries out the installation automatically. Input prompts on the screen guide you step-by-step through the entire installation process.

Proceed as follows:

1. Open the "Control Panel" from the taskbar in Windows (**Start >Settings > Control Panel**).
2. Double-click on the "Add/Remove Programs" icon.
3. Click on the "Install" button.
4. Insert the data medium and click on "Continue". Windows now searches automatically for the installation program, "Setup.exe".
5. Follow the instructions displayed by the installation program step-by-step.
6. When prompted, install the License for Use by the Automation License Manager
7. Install a local modem.
8. Set the Set PG/PC Interface directly afterwards or later.

2.2 Usage Rights through the Automation License Manager

Automation License Manager

To work with TeleService, you require a product-specific license key (right to use the product) that is installed using the Automation License Manager.

The Automation License Manager is a software product of Siemens AG. It is used to manage license keys (technical form of licenses) in various systems.

The Automation License Manager is located:

- On the installation medium of the software product for which a license key is required, or
- On a separate installation medium, and
- On the Web site of A&D Customer Support of Siemens AG as a download.

An online help system is integrated in the Automation License Manager and you can start this for a specific context using the F1 key or open the menu command **Help > Help on the License Manager**. This help system provides you with detailed information on the functions and handling of the Automation License Manager.

Licenses

To use license-protected TeleService program packages, you require licenses. A license provides the right to use products. This right takes the form of:

- The CoL (**C**ertificate **o**f **L**icense) and
- The license key.

Certificate of License (CoL)

The "Certificate of License" is the legal proof of the right to use the software. The product may only be used by the owner of the CoL or an authorized person.

License Keys

The license key is the "technical form" of a license (also referred to as an electronic license stamp).

A license key is issued by SIEMENS AG for every software package that is protected by license. Only after starting up the software on a computer and after the presence of a valid license has been detected, can the software be used according to the conditions of the license and conditions of use stipulated by the license key.

Note

- Unrestricted use of TeleService V6.1 according to the legal licensing agreement is only permitted and only possible with an installed license key.
 - You can familiarize yourself briefly with the user interface and range of functions of TeleService V6.1 using the automatically installed trial license.
-

License keys can be stored and transferred between storage media as follows:

- On license diskettes,
- On local hard disks and
- On hard disks of computer in the network.

If software products are installed and there is no license available for them, you can find out which licenses are required and then order them.

For more detailed information on using license keys, please refer to the online help of the Automation License Manager.

License Types

The following application-oriented license types are available for software products from Siemens AG. The reaction of the software is controlled by the different license keys for these license types. The type of use is specified in the relevant Certificate of License.

License Type	Description
Single License	The software can be used with no time limitation on any one computer.
Floating License	Use of software with no time limitation with the right of use obtained over a network (remote use).
Trial License	The use of the software is restricted as follows:- <ul style="list-style-type: none"> • Valid for a maximum of 14 days, • A certain number of days as of the first use, • Use for tests and validation (disclaimer of liability).
Upgrade License	With an upgrade, specific requirements of the system status may need to be met:- <ul style="list-style-type: none"> • With an upgrade license, a license with an "old" version x can be converted to a version >x+... . • An upgrade may be necessary, for example, to expand the number of connections or nodes.

2.3 Installing the Automation License Manager

The Automation License Manager is installed using an MSI setup. The installation software for the Automation License Manager is on the supplied product CD for TeleService V6.1.

You can install the Automation License Manager along with TeleService or at some time later.

Note

- For detailed information on installing the Automation License Manager, please refer to the latest Readme.wri.
 - The online help on the Automation License Manager contains all the information you require on the functionality and handling of the license keys.
-

Installing License Keys Later

If you start the TeleService software and no license keys are found, you will receive a message to this effect.

Note

- Unrestricted use of TeleService V6.1 according to the legal licensing agreement is only permitted and only possible with an installed license key.
 - You can familiarize yourself briefly with the user interface and range of functions of TeleService V6.1 using the automatically installed trial license.
-

If you install license keys after the product, you have the following options:

- Installing the license keys from diskettes
- Installing the license keys using a Web download (must be ordered in advance)
- Using floating license keys available on the network.

For detailed information on these options, please refer to the online help of the Automation License Manager that can be started in a specific context using the F1 key or opened generally by selecting the menu command **Help > Help on the License Manager**.

Note

- License Keys only work in Windows 2000/XP when they are located on a hard disk for which write access is allowed.
 - Floating licenses can also be used "remotely" over a network.
-

2.4 Rules for Handling License Keys



Caution

Refer to the information on handling license keys in the online help of the Automation License Manager and in the TeleService Readme.wri on the CD-ROM. If you do not adhere to these rules, license keys may be irretrievably lost.

An online help system is integrated in the Automation License Manager and you can start this in a specific context using the F1 key or by selecting the menu command **Help > Help on the Automation License Manager**.

This help system provides you with all the necessary information on the functions and handling of license keys.

2.5 Installing the Software for the TS Adapter

TS Adapter I

To operate the TS Adapter I, no additional software needs to be installed since the "TS Adapter" interface is entered in "Set PG/PC Interface" during with the installation of the TeleService software.

TS Adapter II

To operate the TS Adapter II, you must install the TS Adapter II software in addition to the TeleService software. Otherwise, you cannot switch the "TS Adapter" interface to USB in "Set PG/PC Interface".

TS Adapter IE

To operate the TS Adapter IE, you must install the TS Adapter IE software in addition to the TeleService software. Otherwise, the "TS Adapter IE" interface will be missing in "Set PG/PC Interface".

Note

You can install the software for TS Adapter II and TS Adapter IE both before or after installing the TeleService software.

2.6 Installing the TS Adapter and TS Adapter IE Interfaces

During the installation of the TeleService software and the software for the TS Adapter II and TS Adapter IE, the "TS Adapter" and "TS Adapter IE" interfaces are automatically entered in "Set PG/PC Interface".

The "TS Adapter" interface required for the TS Adapter I/II and the "TS Adapter IE" interface for the TS Adapter IE.

If one of these two interfaces is no longer "Used Interface Configuration" list in the "Set PG/PC Interface", you can enter this interface into the list as described below:

Proceed as follows:

1. Open the "Set PG/PC Interface" dialog box with the menu command **Options > Set PG/PC Interface**.
2. Click "Select". Another dialog box opens.
3. Select the desired interface, for example "TS Adapter" or "TS Adapter IE".
4. Click "Install".
5. Close the dialog box when the installation process is completed.
Result: The list under "Used Interface Configuration" in the "Set PG/PC Interface" dialog box now contains the entry "TS Adapter" or "TS Adapter IE".
6. Close the dialog box with "OK".

2.7 Installing a Local Modem under Windows

If you have already installed a modem for data transfer under your operating system, you can also use this modem for TeleService. If a modem has not been implemented on your operating system, this section will provide information on installing a modem under Windows.

Modems with Plug-and-play Facilities

Plug-and-play modems are recognized and installed automatically by your programming device/PC. Only the dialog boxes for displaying and confirming the installation process are displayed.

Proceed as follows:

1. Make sure that your programming device/PC and the modem are switched off.
2. Connect an external modem physically to a COM or USB interface on your programming device/PC. You can also install an internal modem or a PCMCIA card in accordance with the manufacturer's specifications.
3. First switch on the external modem and then the programming device or the personal computer.

Modems without Plug-and-play Facilities

If your modem is not recognized automatically when switched on, you have to install it yourself by using the Windows Control Panel.

Note

Before installing the modem you should install the latest modem driver on your system. The modem drivers are contained on the diskettes or CD included in the scope of delivery of the modem. Proceed as described in the documentation of the modem manufacturer.

Proceed as follows:

1. Open the Control Panel in Windows and select the "Phone and Modem Options" option.
2. Install the desired modem by filling out the Windows dialog boxes correspondingly. For further information on the procedure please refer to the Windows help function.

2.8 Connecting and Configuring the Remote Modem

Connecting a Remote Modem

To connect a TS Adapter with an external modem, proceed as follows:

1. Switch off the modem.
2. Plug the TS Adapter into the automation system.
3. Connect the TS Adapter to the modem using a modem cable.
4. Connect the modem to the phone line.
5. Switch on the modem.
6. Switch on the TS Adapter.

To connect a TS Adapter with internal modem, proceed as follows:

1. Switch off the TS Adapter.
2. Connect the TS Adapter to the automation system.
3. Connect the TS Adapter to the phone line.
4. Switch on the components.

Configuring a Remote Modem:

The modem receives all the parameters required for operation from the TS Adapter. These are data for initializing the modem and settings for the serial transfer between the TS Adapter and the modem.

The data are specified during the configuration of the TS Adapter. This is described below.

Note

- The parameters for the modem and the serial interface preset in the TS Adapter should ensure successful operation in most cases, so that re-configuration will only be required in rare cases.
 - Re-configuration of the TS Adapter is only necessary if a modem connection is not established or if works settings have to be adapted or optimized.
 - The TS Adapter can be reconfigured over a direct connections or a remote connection.
-

3 Basic Information about TeleService

3.1 Calling from TeleService

TeleService is a separate SIMATIC component.

After you have installed the TeleService software on your programming device/personal computer, you can call up the TeleService via the "Start" button on the Windows task bar (entry under "SIMATIC/TeleService").

If you have installed STEP 7 on your programming device/PC, you can start TeleService in the SIMATIC Manager with the **Options > TeleService** menu command.

Setting the Language

With the **Options > Customize** menu command, you can set the language you require for the TeleService application in the "General" tab.

3.2 The User Interface of TeleService

The user interface of TeleService consists of the following standard components:

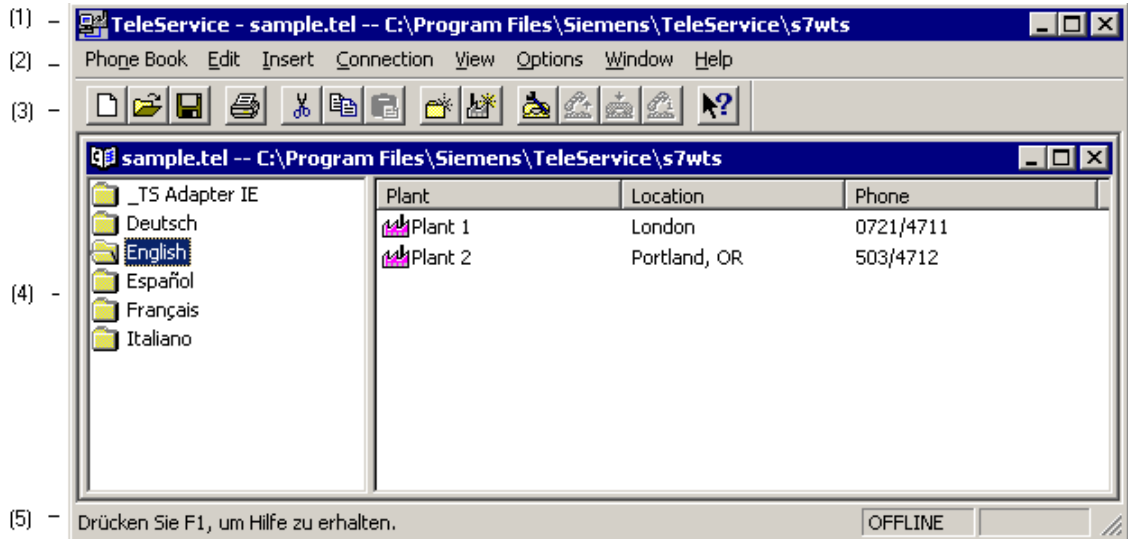

5. **Title bar:**
Contains the window title and icons for controlling the window.
6. **Menu bar:**
Contains all the menus which are available in the window.
7. **Toolbar:**
Contains icons with which you can carry out commands which are often used quickly.
8. **Work area:**
Shows one or more two-section windows with the opened phone books.
9. **Status bar:**
Displays the status and further information on the selected object.

Below the menu bar and the toolbar the TeleService user interface shows one or more two-section windows which display the opened phone books. If you have started TeleService for the first time, the sample phone book (Sample.tel) is opened and displayed – otherwise the last phone books which were opened.

The left-hand section displays the folders existing in the respective phone book. After you have selected a folder, the right-hand section displays the plants, locations and numbers entered in the selected folder.

Displaying the Plants

Plants with a TS Adapter I/II are displayed with a green icon and plants with a TS Adapter IE have a violet icon in the user interface.

Changing and Sorting Plants

You can change the plants by selecting a plant and then calling up the "Object Properties" pop-up menu via the right-hand mouse button. The "**Plant Properties**" dialog box is opened with the "Plant" and "Comment" tabs. Enter the desired changes here and leave the dialog box by clicking on "OK".

You can sort the data displayed on the right alphabetically or in ascending order by clicking on the "Plant", "Location" or "Phone" button.

Establishing a Connection:

You can establish a connection to a displayed plant by double-clicking on the desired plant and then clicking on the "Dial" button in the subsequent dialog box.

3.3 Phone Networks, Modems and Data Throughput

TeleService is used to establish a remote connection to a remote plant via a phone network. The online connection makes it possible to edit the dialed plant as usual with STEP 7.

Phone Networks Which Can Be Used

TeleService can be used with digital networks (ISDN), analog networks and radio networks (with GSM technology). The subsequent table shows the respective transfer duration normalized to the transfer duration of the MPI board (CP 5611 = 1x) and as a function of the set TS Adapter I/II:

Connection:	With TS Adapter I V5.0:	With TS Adapter I V5.1/V5.2:	With TS Adapter II V1.0:
Direct connection (COM, 19.2 Kbps)	8 x	8 x	-
Direct connection (USB)	-	-	2.5 x
ISDN network (64 Kbps)	16 x	11 x	8 x
Analog network (28.8 Kbps)	32 x	14 x	11 x
Radio network (9.6 Kbps)	150 x	40 x	30 x

Limitations

Communication with the TS Adapter via the CAPI interface is not possible in case of internal ISDN boards and PCMCIA boards, unless you are equipped with a virtual COM interface of the modem manufacturer.

Modem Support

TeleService was implemented to be independent of the modem. This means that all the common modems (Hayes-compatible/AT commands) which can be installed in the Control Panel of Windows can also be used by TeleService.

Basic requirement is that a physical/virtual COM interface must exist. The choice of the modem types is determined primarily by the existing hardware of the programming device/personal computer and the phone network to be used.

A selection of the following modem types/media is supported:

- Modems (external modems at COM interface, internal modems and PCMCIA boards),
- External ISDN adapter at the COM interface
- Internal ISDN adapter with virtual COM interface (for example, AVM CAPI port)
- External ISDN modems (ISDN adapter with integrated analog modem functionality) at the COM interface
- Radio network modems with GSM technology, PCMCIA adapter board or data cable and mobile phone

Gateways

Gateways between the various phone networks are theoretically possible. Remote connections from an ISDN adapter to an analog modem and vice versa only work with special ISDN-TAs.

Performance in Phone Networks

The data throughput of a remote connection depends on the modem used, the phone network used and on the quality of the phone line.

The properties of an active remote connection can be displayed in TeleService. At present one remote connection to a TS Adapter is supported in this version.

3.4 How the TS Adapter I/II Works

Configuration

Depending on the configuration, the TS Adapter I/II connects the serial port or the USB port of your programming device (direct connection) or the serial port of a modem (modem connection) with the MPI/PROFIBUS network of your automation system.

The TS Adapter I/II disposes of a non-volatile memory. Parameters for the following functions are saved in this memory:

- The MPI/PROFIBUS network (network parameters)
- The operation of the modem used
- The serial interface to the Modem
- The access protection

Standard Configuration

The TS Adapter is supplied with a standard configuration. The parameters can be set during a parameter configuration session and are written back to the non-volatile memory of the TS Adapter.

In the direct connection configuration, the TS Adapter only uses the network parameters for access to the MPI/PROFIBUS network.

In the modem connection configuration, all the parameters stored on the TS Adapter are activated.

3.5 How the TS Adapter IE Works

Configuration

The TS Adapter IE connects the telephone network or the serial interface of a modem to the Industrial Ethernet of your automation system.

The TS Adapter IE features non-volatile memory. Parameters for the following functions are stored in this memory:

- The mode of the employed modem
- The serial interface to the modem
- The access protection

3.6 Using the TS Adapter for TeleService

Connection Options

A TS Adapter is required in order to use TeleService.

This provides various connection options.

Operating with TS Adapter I/II:

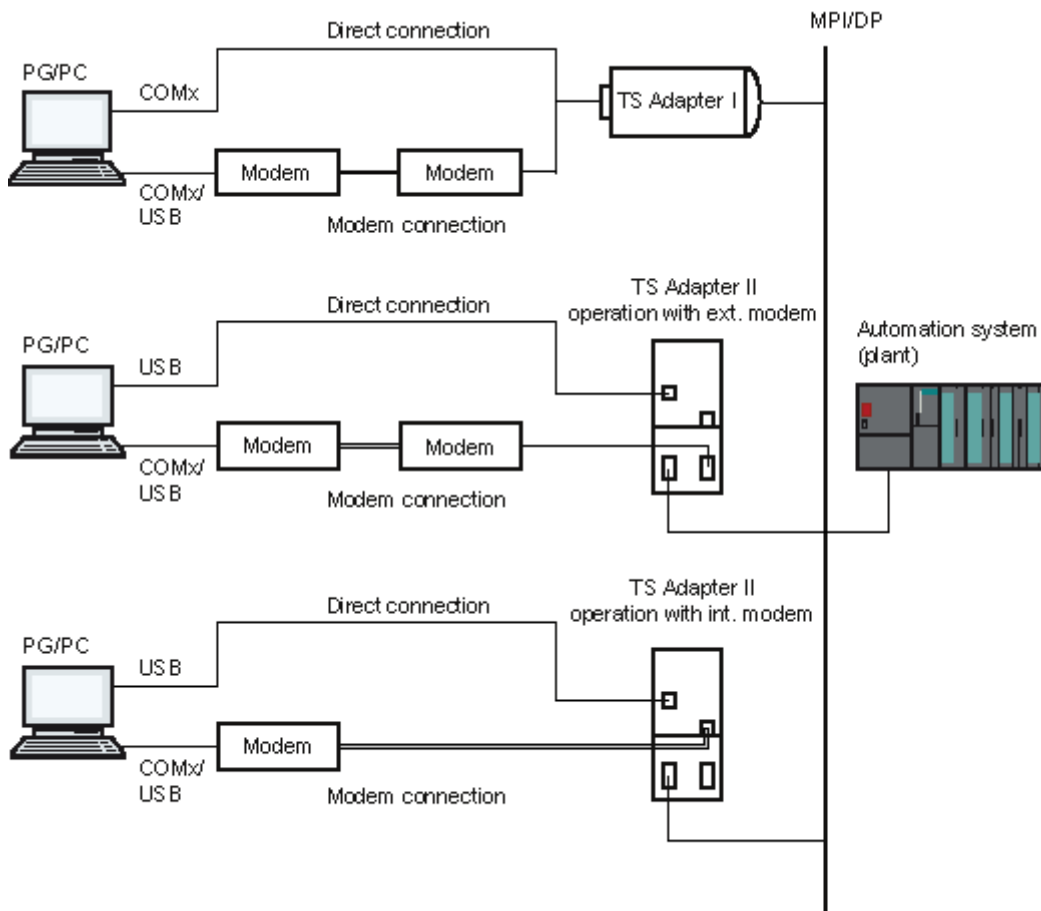

Direct Connection with TS Adapter I/II

The option of connecting a programming device or a PC directly (without modem) to an automation system (direct connection).

By this method it connects the programming device/personal computer to the MPI-/DP interface of a SIMATIC S7/C7 system without occupying a slot in the programming device/personal computer.

Modem Connection with TS Adapter I/II

The option of accessing an automation system from a programming device/PC over a modem (modem connection).

With this type of connection, the programming device or PC is connected to the MPI/PROFIBUS network of the automation system over the remote connection and the TS Adapter. This configuration allows you to dial directly into a remote plant.

Switching

To switch the operating mode use "Set PG/PC Interface".

Simultaneous Operation of Direct and Modem Connection

The TS Adapter II has two ports for communication with the programming device that can both be connected at the same time. You connect the USB port with the programming device/PC and the modem port with the telephone network. In this configuration, you can either use the direct or the modem connection. Simultaneous use is not possible.

Operating with TS Adapter IE:

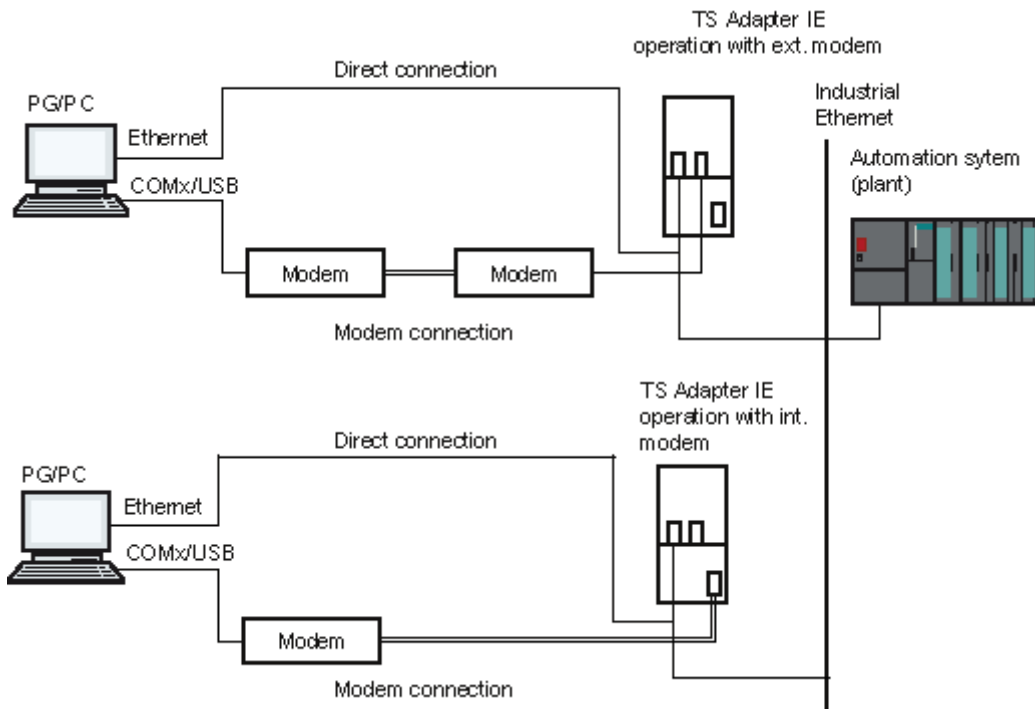

Direct Connection with TS Adapter IE

The capability to directly access a TS Adapter IE (without modem) from PG/PC in order to configure the adapter.

Modem Connection with TS Adapter IE

The capability to access an automation system from a PG/PC via a modem (modem connection).

This configuration enables you to dial from a remote plant.

3.7 Operating the TS Adapter with a Direct Connection

Direct Connection with TS Adapter I/II

The direct connection is used essentially to configure the TS Adapter I/II. In the same configuration you can also go online in STEP 7 and thus check the configured MPI/PROFIBUS parameters for bus compatibility. This means that (as with a PC adapter) SIMATIC S7/C7 systems can be accessed over the MPI/DP interface without an MPI/PROFIBUS module occupying a slot for a programming device/PC.

Access protection for the TS Adapter is not active in the direct connection configuration. This means that the configuration of the TS Adapter can be changed without any problems, for example by importing adapter parameters.

Configuration of the Direct Connection for TS Adapter I/II

With a direct connection, there is a direct connection between the programming device/PC on which TeleService is installed and the automation system over the TS Adapter. A modem is not required.

On a direct connection, the TS Adapter I can operate at 19200 bps or 38400 bps. To change the speed, set the switch on the TS Adapter and also change the parameter in the software with "Set PG/PC Interface".

With the TS Adapter II, select direct connection over USB in "Set PG/PC Interface".

The following figure shows the configuration of the TS Adapters I and II with a direct connection.

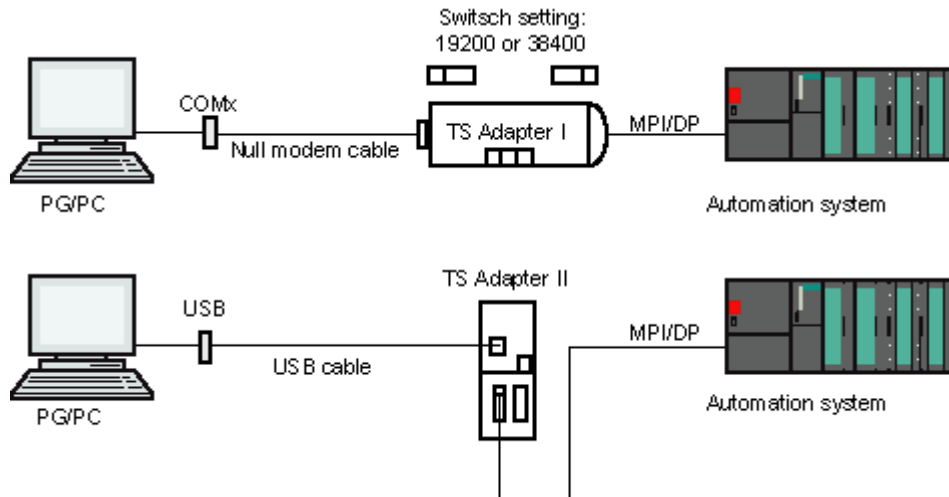

Notes on Cabling the TS Adapter I

There is a 9-pin male connector on the optional null modem cable of the TS Adapter. A suitable adapter may be required to connect to a COM port of the programming device/PC.

The table below shows the cable connection at the programming device/PC.

Device:	Connector:	Cable connection:
Programming device	COM 2 as 9-pin connector	Additional zero-modem cable
Programming device	COM 1 as 25-pin socket	Additional adapter and zero-modem cable
PC	COM 1 or COM 2 as 9-pin connector	Additional zero-modem cable
PC	COM 1 or COM 2 as 25-pin connector	Additional adapter and zero-modem cable

Direct Connection with TS Adapter IE

The direct connection is used to configure the TS Adapter IE.

Establishing the Direct Connection for TS Adapter IE

The TS Adapter IE is connected directly to the Ethernet connection of the PG/PC. No modem is required. The following figure shows the configuration with direct connection of the TS Adapter IE.

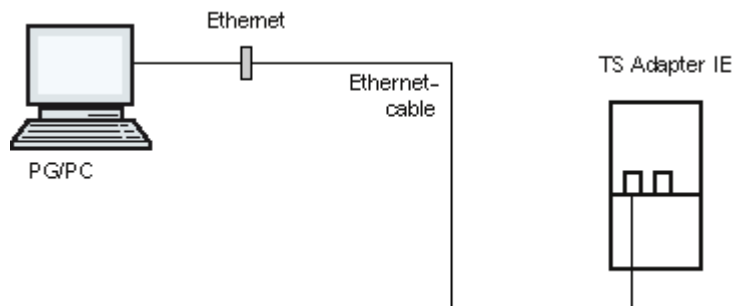

3.8 Operating the TS Adapter with a Modem Connection

Configuration of a Modem Connection with TS Adapter I/II

The connection between the programming device or PC on which the TeleService is installed and the automation system onto whose MPI/DP interface the TS Adapter I/II is plugged is implemented via a modem connection.

The configuration thus connects the programming device or the personal computer via the phone network and the TS Adapter I/II to the MPI/DP interface of the automation system.

The following figure shows the TS Adapter I/II with a modem connection:

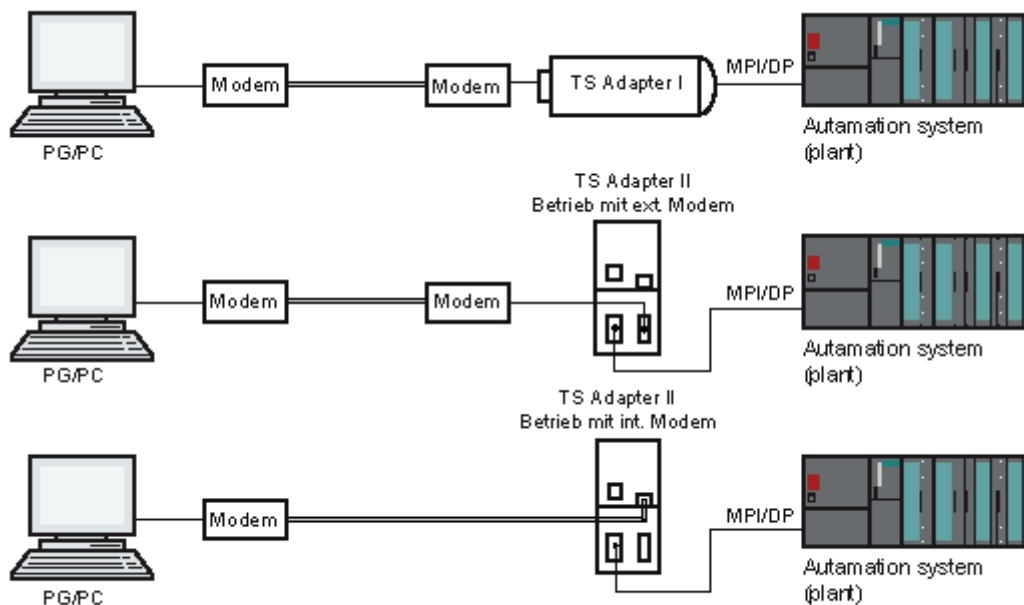

Purpose

This configuration allows you to dial directly into a remote plant. To this purpose you use TeleService to establish a remote connection to a remote plant via a phone network. The established modem connection can then be used to process the dialed plant as usual with STEP 7.

Information on Cabling

The components to be cabled have to be switched off. There must be a 9-pin socket on the modem cable to connect the TS Adapter. Otherwise a suitable adapter connector is required.

The following figure shows connectable modem cables (if necessary via an adapter connector).

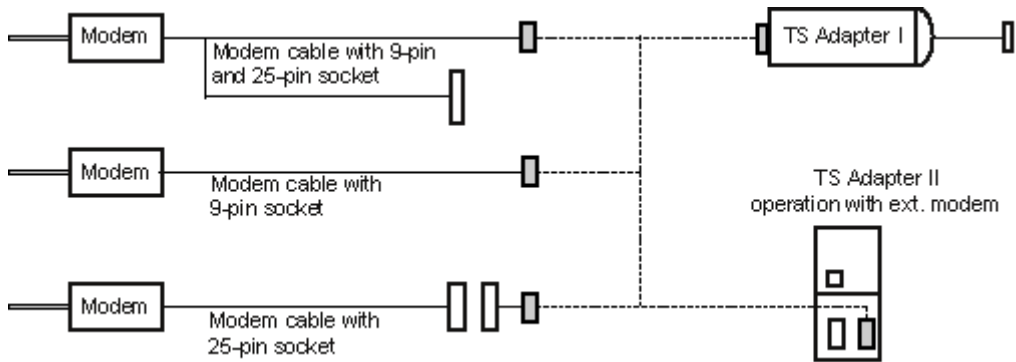

Establishing a Modem Connection for TS Adapter IE

The connection between the PG or PC on which TeleService is installed and the automation system to which TS Adapter IE is connected via Ethernet is established via a modem line.

The configuration therefore connects the PG or PC via the telephone network and the TS Adapter IE to the Ethernet of the automation system an.

The following figure shows the configuration with modem connection of the TS Adapter IE.

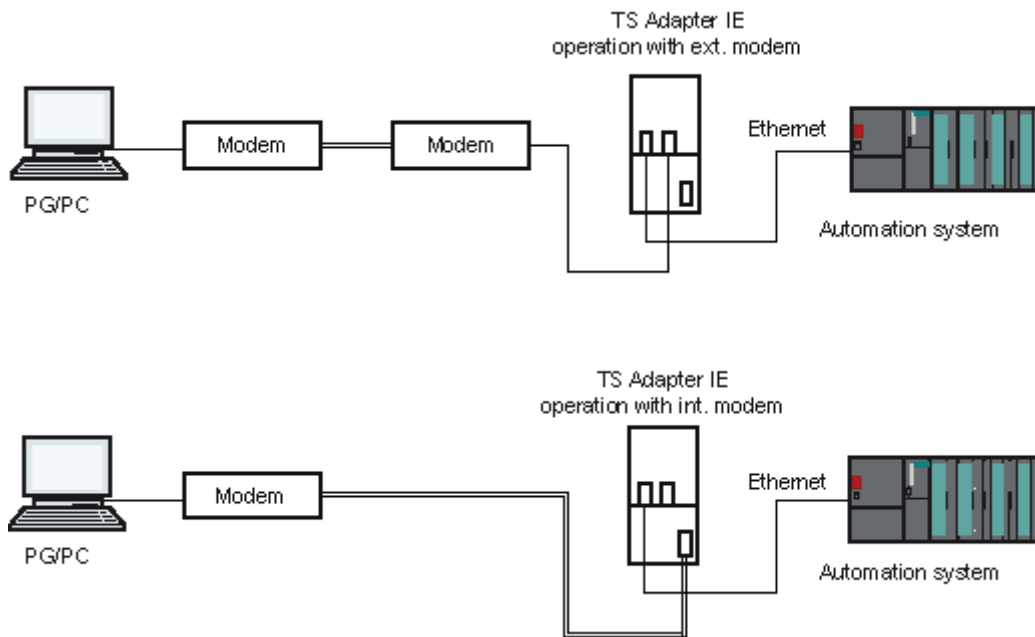

Purpose

This configuration allows you to dial in a remote plant. To do this, you establish a remote connection to the remote plant via a telephone network with TeleService. You can then work with STEP 7 as usual over the established modem connection.

3.9 Useful Information on Access Protection for the TS Adapter I/II

The TS Adapters as Supplied

Access protection is not activated when the TS Adapters I/II is delivered. The first user who configures this adapter can therefore activate access protection by defining the password for a user and/or a callback number.

This access protection exists only for remote connections. When using a direct connection, you can access the parameters on the adapter at any time.

Setting Up Access Protection

When you set the parameters for your TS Adapters I/II, you can restrict access to the parameters of the adapter as well as access to remote plants.

The protection is a multi-level access protection with one administrator and a maximum of two users who can each define an own password and/or a callback number.

You have the following options:

Level of Access Protection	Administrator/ User Password	Callback Number
1.	enter	do not enter
2.	enter	enter

Access Protection Level 1

The TS Adapters I/II is protected by the user name and password. You can access the TS Adapter from **any phone** and specify any callback number during connection establishment.

Access Protection Level 2

The TS Adapters I/II is protected by the user name, password, and the callback number. You can access the TS Adapters I/II **only from one phone per user**.

Logging on with the TS Adapter I/II

When you log on with the TS Adapters I/II, after you have set up access protection, enter your user name, the corresponding password and, as an option, a callback number:

Level of Access Protection	Administrator/ User Password	Password	Callback Number
1.	enter	enter	do not enter or enter any callback number
2.	enter	enter	do not enter

If you entered a callback number during connection establishment (access protection level 1) or you stored a callback number on the TS Adapters I/II (access protection level 2), the modem connection is terminated and the TS Adapters I/II calls the specified number back.

This has the following advantages:

- Unauthorized access by outside persons is almost impossible.
- The plant operator bears the main part of the phone costs.

Information

- To be sure that the callback functionality works, ensure that the settings in the "Modem" tab correspond to the conditions at the plant.
 - If you enter an incorrect callback number in the role of "ADMIN" user, you can no longer reach the TS Adapter I/II **over a remote connection!**
 - Tip: Test the callback number before you enter it as the "ADMIN" user by entering the number during connection establishment (access protection level 1).
-

Setting Up Access Protection

If you have a modem connection only the administrator may set up the two users, change their settings, and delete them again, if required. If you log in as a user, you can only change your own password and your own callback number. All the other parameters of the TS Adapter can only be read.

3.10 Useful Information on Callback

The costs of a phone connection are normally borne by the caller that sets up the TeleService session.

TeleService can, however, be used so that after a short initial connection, the modem connection is established again in the opposite direction, in other words initiated by the TS Adapter (callback). In this case, the plant operator bears the costs for the callback.

There are two callback variants in TeleService:

1. Callback to a number specified during connection establishment.
2. Callback to a number stored on the TS Adapter.

Callback to a number specified during connection establishment

1. Open the "Set PG/PC Interface" dialog box.
2. Select the "TS Adapter" or "TS Adapter IE" interface.
3. Click "Properties", open the "Local Modem" tab and specify the location from where you wish to configure the remote connection.
4. Activate the "Connection establishment with callback" check box. As long as this box is checked, the dialog "Log onto TS Adapter" opens when a connection is established and displays a callback number suitable for the location that you can, if necessary, correct, confirm, or reject.

Note

This procedure is suitable when the costs for the modem connection will be borne by the plant and when the callback number is not fixed and different recipients can be called back. This is particularly suitable for mobile users.

Callback to a number stored on the TS Adapter

- Store a callback number on the TS Adapter and familiarize yourself with the access protection for the TS Adapter I/II and the TS Adapter IE.

Note

This method represents the highest level of security. The danger with this method is that if the number stored on the TS Adapter is not correct, it will no longer be possible to reach the TS Adapter over a modem connection. The device can then only be put back into operation by changing the parameter settings locally (on site).

3.11 Useful Information on TeleService Logbook

TeleService logs all remote connections in a logbook:

This logbook is located in the TeleService installation directory (for example C:\program files\siemens\teleservice\S7wts) and has the name "TeleService-Log_YYYYMM.xml". "YYYY" stands for the respective year, "MM" for the respective month when the logbook was created.

TeleService begins a new logbook each month, for example "TeleService-Log_200606.xml" contains all connections that were started in June 2006.

The logbook is an XML file that can be imported into Microsoft Excel for further evaluation.

The following information is stored for each connection:

- **date and time**
Start time of the connection (date and time)
- **duration_in_sec**
Duration of the connection in seconds
- **phonenumber**
Telephone number of the called TS Adapter (callback = no) or telephone number of the calling TS Adapters (callback = yes)
- **callback**
Type of the connection (call or callback)
- **username**
User name used
- **plant**
Name of the plant to which the connection was established
- **phonebookentry**
Name of the phone book entry used for the connection. The name consists of three parts:
 1. The phone book name including path
 2. The folder name and
 3. The plant nameThe "\" character is used as the separator.

3.12 Information Functions in TeleService

Status Bar

The status bar of the TeleService dialog box displays whether a remote connection is active (ONLINE) or not (OFFLINE).

If ONLINE is displayed, the period which has passed since the connection was established is indicated in the adjacent field.

With a connection to a TS Adapter I/II the ONLINE field is green and for a connection to a TS Adapter IE the ONLINE field is violet.

Displaying the Data on the Current Connection

In TeleService you can display information on the current connection using the **Connection > Current Connection** menu command or by clicking on the corresponding button.

Displaying the Version of the TS Adapter

You have the following options for displaying the version of your TS Adapter:

- After you have established a connection select the **Connection > Current Connection** menu command or click on the corresponding button. In addition to the other data the version of the TS Adapter is also displayed.
- With a direct connection, select the **Options > Assign TS Adapter I/II Parameters** menu command. The "About" tab then displays the version of the TS Adapter I/II.
- With a direct connection, select the **Options > Administer TS Adapter IE** menu command. The version of the TS Adapter IE is then displayed in the Web interface.

4 Setting the Parameters for TeleService

4.1 Overview of Local and Remote Settings

If you want to carry out teleservicing, you must operate the TS Adapter as a modem connection. To this purpose you have to carry out local settings in TeleService and to configure the TS Adapter.

The following figures provides an overview of the required settings.

The arrows identify the components of the transfer path to which the respective settings refer.

Operating with TS Adapter I/II

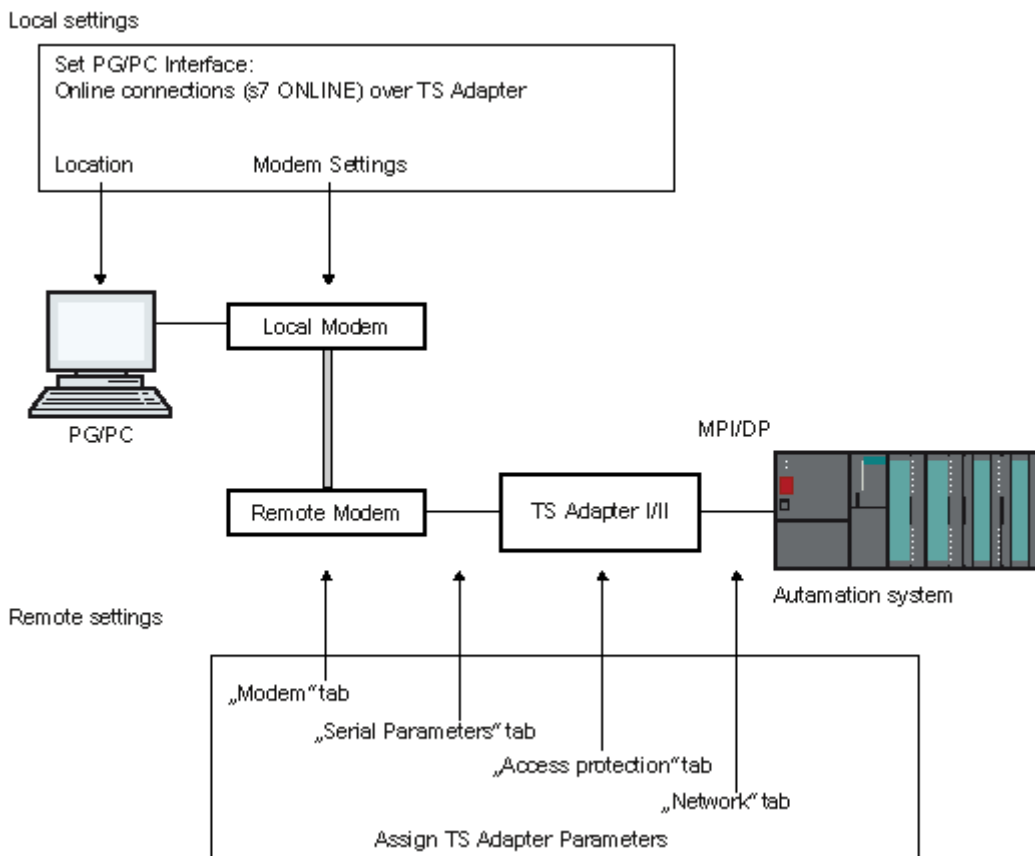

Operating with TS Adapter IE

Local settings

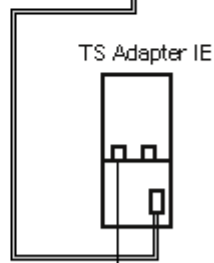
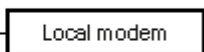
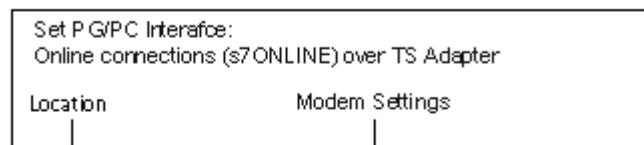

Ethernet



Remote settings

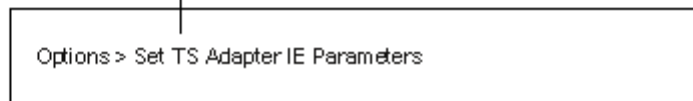

4.2 Setting the PG/PC Interface

Requirements

If you wish to use a remote connection with STEP 7, you need to first set certain parameters. These settings configure the local interface.

Proceed as follows:

1. Start TeleService and open the "Set PG/PC Interface" dialog box from the **Options** menu.
In the "Access Point of the Application" list, select "S7ONLINE (STEP 7)" for example, if you have installed STEP 7 or "Micro/WIN" if you have installed STEP 7-Micro/WIN as the access point.
2. In the "Used Interface Configuration" field, select either the "TS Adapter" interface for the connection to a TS Adapter I/II or the "TS Adapter IE" interface for the connection to a TS Adapter IE.
3. Click "Properties" to specify additional parameters for the selected interface. For example, you set a modem or a direct connection for the "TS Adapter" interface, or a local modem and select your location.
4. For a direct connection, specify the local interface to which your TS Adapter I/II is connected (for example, COM1 for TS Adapter I or USB for TS Adapter II).
5. Select a local modem and your location.
6. Close the "Properties" dialog box with "OK".
7. Confirm your changes with "OK".
8. You can obtain detailed help about "Set PG/PC Interface" by pressing the F1 key in the dialog box you are working in.

Note

Ensure that the "Access point of your application", for example "S7ONLINE (STEP 7)", is assigned the correct interface.

If the access point is set to the "TS Adapter" interface, for example, because you are currently accessing a plant with a TS Adapter I or II, the access point must be reset to the "TS Adapter IE" interface before accessing a plant with a TS Adapter IE.

4.3 Local Settings at the PG/PC End

4.3.1 Local Parameters in TeleService

Make the following local parameters in TeleService:

- The language of the TeleService application
- The monitoring times for the transmission protocol
- The interface for the directly connected TS Adapter IE

Make the following settings in the "Set PG/PC Interface" dialog box:

- The TeleService-specific modem properties
- The location and the corresponding dialing parameters

4.3.2 Useful Information on Setting Modem Properties

Saving the Modem Properties in TeleService

When you define the settings of the modem connected locally with the menu command **Options > Set PG/PC Interface**, the defined settings are saved by TeleService and are used when the next remote connection is established by TeleService.

TeleService-specific saving of the modem properties offers the advantage that TeleService always uses the same saved settings when establishing a remote connection. TeleService is thus not influenced by the question which application the modem last used, or whether the modem settings have been changed via the Control Panel in the meantime.

Setting Options

You can use the **Control Panel** to set the modem properties specified below, whereby these have different effects on the system and on TeleService:

- **General modem properties:**
Changes which you carry out on the general modem properties (volume of the modem loudspeaker, maximum transfer rate and dial option "Wait for dial tone before dialing") act directly on TeleService.
- **Settings for the log file and further initialization commands at the modem:**
These settings which are carried out in the Control Panel act directly on TeleService.
- **Default settings:**
Default settings made in the Control Panel do **not** affect TeleService. You should therefore always make the default with the menu command **Options > Set PG/PC Interface**. You can only carry out these default settings in TeleService.

Note

The general modem properties, the settings for the log file as well as further initialization commands to the modem should only be changed in the Control Panel, "Phone and Modem Options" option.

4.3.3 Setting the General Modem Properties

Proceed as follows in order to change the settings:

1. Call up the "Phone and Modem Options" option in the Control Panel.
2. Select the "Modems" tab.
3. Select the modem whose general properties you want to change.
4. Click on the "Properties" button. The "Properties ..." dialog box then opens.
5. Select the "Modem" tab.
6. Carry out the desired changes to the general modem properties.
7. Then close the dialog box by clicking on the "OK" button.
8. Terminate the "Phone and Modem Options" options by clicking on the "OK" button.

4.3.4 Setting the TeleService-Specific Modem Properties

Proceed as follows to set the modem properties:

1. Select the menu command **Options > Set PG/PC Interface** in TeleService.
2. Select the interface "TS Adapter" or "TS Adapter IE". The "TS Adapter" interface is intended for connections to a TS Adapter I/II and the "TS Adapter IE" interface is for connections to a TS Adapter IE.
3. Click "Properties". The "Properties - TS Adapter" or "Properties - TS Adapter IE" dialog box opens.
4. Open the "Local Modem" tab.
5. Select the modem to be used for the remote connection from the list box. Only the modems installed in Windows are listed.
6. Click on the "Properties" button in order to define the TeleService-specific properties of the modem. A dialog box with the connection settings of the selected modem opens.
Define the properties of the TeleService modem here.

Note

- The dialog box with the connection settings can also be called up via the Control Panel of Windows. However, the changes entered there do not have any effect on the database in TeleService and have to be entered once again here.
 - Always define the properties of the TeleService modem as described here directly in TeleService. This has the advantage that any changes carried out in the Control Panel for other programs do not have any effect on the settings selected in TeleService. As a rule the required parameters are already set so that the entries only have to be checked.
-

7. Click on "OK" for TeleService to save your settings.
8. Exit the dialog box by clicking "OK".

4.3.5 Defining the Location and the Corresponding Dial Parameters

Proceed as follows:

1. Select the menu command **Options > Set PG/PC Interface** in TeleService.
2. Select the "TS Adapter" or "TS Adapter IE" interface. The "TS Adapter" interface is intended for connections to a TS Adapter I/II and the "TS Adapter IE" interface is for connections to a TS Adapter IE.
3. Click "Properties". The "Properties - TS Adapter" or "Properties - TS Adapter IE" dialog box opens.
4. Open the "Local Modem" tab.
5. Click "Edit".

or

Start the "Phone and Modem Options" option in the Control Panel.

Result: The "Phone and Modem Options" dialog box is displayed.

Note

It is irrelevant by which method you specify the settings in this dialog box. Your settings are always saved in the current system data and displayed as the default setting when the dialog box is called up again.

6. In the "Dial Rules" tab select the desired location and click on the "Edit" button or create a new location by using the "New" button.
Result: The "Edit Location" dialog box is opened.
7. Enter the corresponding area code and the country or region in the case of a new location.
8. Set the correct access code for local/remote calls:
If your modem is operated from a **main connection**, you must not specify an access code in the "Edit" dialog box. The fields for the access code for local calls and remote calls have to be empty.
If you are operating your modem on an **extension**, specify the number that must be dialed to obtain a direct exchange line.
For example, you can specify:
 - "0," or "9,,": for private branch exchange systems that do not produce any original dial tone, there is a dialing pause of 1 s (" ,") or 2 s (" ,,") after the "0" or "9" during dialing, with no waiting for a dial tone.

You must then **under no circumstances** activate the "Wait for dial tone before dialing" check box in the "General" tab in the "Properties" Windows dialog box.
 - If you use the modem at a main connection, you may not enter an access code.
9. Set the dialing method (tone or pulse dialing) common for your phone connection. During pulse dialing you hear crackling noises. During tone dialing you hear noises with varying tone heights.
10. Close the "Phone and Modem Options" dialog box and enter the phone number of the location in the "Local Modem" tab of the "Properties..." dialog box.
11. Exit the "Properties..." dialog box by clicking "**OK**".

5 Configuring the TS Adapter I/II

5.1 Useful Information on Configuring the TS Adapter I/II

The TS Adapter can be configured both in direct connection mode as well as via an existing remote connection.

Note

- If you change the current parameter settings when there is an established remote connection, there is the risk that it will no longer be possible to establish a modem connection with the modified parameters. In this case the TS Adapter I/II can only still be configured in direct connection mode.
 - This means that the configuration has to be carried out with a programming device/personal computer at the site of the plant or that the TS Adapter I/II has to be brought to the location of the local programming device/personal computer in order to be configured.
-

Positive Acknowledgement

During configuration the data are written into the non-volatile memory of the TS Adapter. The configuration process is not acknowledged positively until all precautions have been taken to ensure that parameter changes have been carried out correctly and thus survive a power failure.

Changes become effective for TS Adapter I/II as follows:

The serial parameters, the modem parameters and the parameters for the access protection are activated after the remote connection has been disconnected.

The modified network parameters are activated immediately.

5.2 Overview of the Configuration Options for the TS Adapter I/II

You have the following configuration options for the TS Adapter I/II:

- Procedure for Configuring the TS Adapter I/II
- Restoring the Default Configuration of a TS Adapter I/II
- Exporting Adapter Parameters for the TS Adapter I/II
- Importing Adapter Parameters for the TS Adapter I/II

5.3 Procedure for Configuring the TS Adapter I/II

You can configure the TS Adapter I/II with both a direct connection and a modem connection via an established remote connection.

1. Select the menu command **Options > Assign TS Adapter I/II Parameters**. The "Assign TS Adapter I/II Parameters" dialog box then opens.
2. Set the required parameters in the tabs of the dialog box.
3. Confirm your settings with **"OK"**. The parameters are then saved in the non-volatile memory of the TS Adapter I/II.

You can obtain detailed help about the individual options in the tabs by pressing the F1 key in the dialog box.

5.4 Switching between Direct and Modem Connections with the TS Adapter I/II

Proceed as follows:

1. Select the menu command **Options > Set PG/PC Interface**.
2. In the "Access point of the application" list box, select, for example, "S7ONLINE (STEP 7)" as the access point if you have installed STEP 7 or "Micro/WIN" if you have installed MicroWin.
3. Select the "TS Adapter" interface in the "Used interface configuration" field. Note that this changes the assignment in STEP 7 of the module with which STEP 7 goes online.
4. Use the "Properties" button to define the further parameters for this interface. Specify whether the TS Adapter I/II is to be operated with a modem or direct connection.
5. If you have a direct connection with a TS>SP>Adapter I, also specify the local COM connection of your programming device/personal computer to which the TS Adapter is connected as well as the transfer speed between the programming device/personal computer and the TS Adapter (19,200 bps or 38,400 bps).
If you have a direct connection with a TS Adapter II, select the "USB" setting.
6. Then confirm both dialog boxes by clicking on "OK".

Detailed help on "Set programming device/personal computer interface" can be accessed by pressing F1 while you are positioned in the corresponding dialog box.

Note

TeleService functions are not supported by the PC/MPI cable and by the PC Adapter.

5.5 Setting Up Access Protection for TS Adapter I/II

In TeleService, you can set up access protection for the configuration of TS Adapter I/II and for the connection to a remote plant when you set the adapter parameters.

Proceed as follows:

1. Select the menu command **Options > Assign TS Adapter I/II Parameters**. The "Assign TS Adapter I/II Parameters" dialog box then opens.
2. Open the "Access Protection" tab.
3. Enter a password for your user name and/or a number to be used by the modem for a callback after the logon.

Note

- If you are logged in as an administrator, you can change all the settings for administrators and users as well as set up or delete users.
 - If you are logged in as a user, you can only change your own settings (password and callback number).
-

4. Confirm with "OK". The parameters are then saved in the non-volatile memory of the TS Adapter I/II.

5.6 Exporting Adapter Parameters for TS Adapter I/II

You can export the configuration of a TS Adapter I/II to a file (*.tap). The configuration saved in this file can be imported into any number of TS Adapter I/II. This is advisable, for example, if you want to configure several TS Adapter I/II identically or if you want save, document or distribute the parameter set. To export you can either work with a direct connection or log on as an administrator.

Proceed as follows:

1. Select the menu command **Options > Export TS Adapter I/II Parameters**.
2. A dialog box is then opened in which you can select the file into which you wish to export the configuration of the TS Adapter I/II.
3. Confirm with "Save". The parameters of the TS Adapter I/II are then saved in the specified file (*.tap).

5.7 Importing Adapter Parameters for TS Adapter I/II

You can import the configuration of a TS Adapter I/II from a previously created export file (*.tap). The configuration saved in this file can be imported into any number of TS Adapters. This is advisable, for example, if you want to configure several TS Adapter I/II identically. You can import when operating with a direct connection or a modem connection (via an established remote connection).

Proceed as follows:

1. Select the menu command **Options > Import TS Adapter I/II Parameters**.
2. A dialog box is then opened in which you can select the file whose configuration you wish to import into the TS Adapter I/II.
3. Confirm with "Open". The parameters are then saved in the non-volatile memory of the TS Adapter I/II.

5.8 Restoring the Default Configuration of a TS Adapter I/II

You can restore the default configuration with which the TS Adapter I/II is supplied at any time with the **Options > Reset TS Adapter I/II Parameters** menu command.

5.9 Modem Initialization String for the TS Adapter I/II

5.9.1 Properties of the Modem Initialization String for the TS Adapter I/II

The initialization string is a string consisting of AT commands (quasi-standard commands for modems) with which the modem connected to or integrated in the TS Adapters I/II is initialized.

Although you can change the character string, it must satisfy certain requirements for initialization.

Requirements

The following modem properties have to be set with the initialization string:

- The modem provides feedback messages.
- The feedback is output in clear text.
- The DCD signal is only activated when a connection exists.
- The interface speed between the TS Adapter I/II and the Modem is not changed after the connection has been established.
- The RTS/CTS protocol is active as a flow control between the TS Adapter I/II and the programming device or PC respectively.
- The automatic call acceptance by the modem is activated.

5.9.2 Preset Modem Initialization String for the TS Adapter I/II

The TS Adapter I/II is supplied with a standard value for the initialization.

Note

The initialization string is selected so that most modems can be configured and initialized correctly. It is not optimized for a specific modem.

The exceptions are listed in the table below.

Modem:	Replace ...	By ...
US Robotics Sportster 28.8 Vi	&F	&F1
US Robotics Sportster 33.6	&F	&F1
US Robotics 56K Message	&F	&F1

For further special settings please refer to the SIMATIC hotline, if necessary.

5.9.3 Initialization after Return of Power for the TS Adapter I/II

As from TeleService V5.0 the configurable initialization string is subdivided into two logical partial strings:

- <Initstring1>;<Initstring2>

Initstring1 is transferred once from the TS Adapter to the connected modem after the restart/return of power. Irrespective of whether the modem acknowledges Initstring1 with "OK" or with "ERROR", Initstring2 is then transferred for the actual initialization of the modem.

This configuration possibility enables initializations which may/must only be carried out once.

An example is the PIN transfer to a radio component, such as the Siemens M1 module. The initstring can be configured as follows to this purpose:

- AT+CPIN="4711";AT&F.....

After the power has returned the TS Adapter I/II sends the string "AT+CPIN="4711" once with the PIN for the SIM card used in the M1 module to the connected component. The component is then initialized with "AT&F...".

Note

The character ";" is used to separate Initstring1 and Initstring2 and may therefore only be inserted to this purpose in the initialization string.

6 Configuring the TS Adapter IE

6.1 Procedure for Configuring the TS Adapter IE

You can set the TS Adapter IE parameters both with a direct connection and over an established remote connection with a modem connection.

1. Select the **Options > Assign TS Adapter IE Parameters** menu command.
The configuration interface for the TS Adapter IE opens.
2. Set the required parameters in the configuration interface.
3. Close the configuration interface.

Note

You can find detailed information about setting the parameters and additional information in the help for the configuration interface and in the documentation for TS Adapter IE.

6.2 Assigning IP Parameters of the TS Adapter IE

You can set the IP parameters of the TS Adapter IE only with a direct connection.

Proceed as follows:

1. Select the menu command **Options > Assign TS Adapter IE IP Parameters**.
The corresponding dialog box opens.
2. Enter the required IP parameters.
You can obtain detailed help about the individual parameters by pressing the F1 key.
3. Confirm your settings with "OK".

Note

You can find detailed information about setting the parameters and additional information in the documentation for TS Adapter IE.

6.3 Setting the Interface for a Directly Connected TS Adapter IE

You can select the interface for a direct connected TS Adapter IE in TeleService.

Proceed as follows:

1. Select the menu command **Options > Customize**. The "Customize" dialog box opens.
2. In the "General" tab, specify the interface to which your TS Adapter IE is connected (direct mode).
3. Confirm your settings with "OK".

Note

You can find detailed information in the documentation for the TS Adapter IE.

7 Accessing Remote Plants (Remote Maintenance)

7.1 Establishing a Remote Connection

Requirements

You can establish a remote connection to a plant after you have installed a modem, made all necessary settings and saved the plant data. These plants can then be edited as usual with STEP 7.

Proceed as follows:

1. Start TeleService.
2. Open a phone book.
3. Select in a folder the plant to which you want to establish a remote connection.
4. Call up the "Establish Connection" dialog box by:
 - Selecting the **Connection > Establish** menu command or
 - Clicking on the corresponding button in the toolbar or
 - Double-clicking on the plant to which you wish to establish a remote connection.
5. In the dialog box enter the modem that is to be used for the remote connection together with the location, the user name and the password.
6. Click on the "Dial" button.
7. The remote connection is established.
Result: The dialog box disappears when the remote connection has been established. The "ONLINE" status and the connection time are displayed in the status bar. An icon is furthermore displayed in which you can call up the connection properties.
8. You can now use the remote connection with STEP 7 and so communicate with the automation system.

If the connection cannot be established ...

If the connection cannot be established, try to find the cause by using the Troubleshooting checklists".

Editing the remote plant

Once the remote connection has been established, you can change to the SIMATIC Manager, create an online connection (Window with "Online View" of the project or "Available Users" window) and edit the remote plant.

Disconnecting the connection

Once you have completed editing the remote plant with STEP 7, close the windows in which the online views were displayed in STEP 7.

Then change back to TeleService and disconnect the remote connection by using the **Connection > Disconnect** menu command.

7.2 Using the Remote Connection with STEP 7

Requirement

After you have established a remote connection to a remote plant using TeleService, you can work in the plant as usual with STEP 7.

This assumes you have correctly set the access point of the application beforehand.

Proceed as follows:

1. Open the "Set PG/PC Interface" dialog box with the menu command **Options > Set PG/PC Interface**.
2. Set the access point of the "S7ONLINE (STEP 7)" application to the "TS Adapter" or "TS Adapter IE" interface.

Use the "TS Adapter" interface for connections via a TS Adapter I/II and the "TS Adapter IE" interface for connections via a TS Adapter IE.

Note

- Ensure that the "Access point of your application", for example "S7ONLINE (STEP 7)", is assigned the correct interface.
 - If the access point is set to the "TS Adapter" interface, for example, because you are currently accessing a plant with a TS Adapter I or II, the access point must be reset to the "TS Adapter IE" interface before accessing a plant with a TS Adapter IE.
-

7.3 Using the Remote Connection with Micro/WIN

Requirement

After you have established a remote connection to a remote plant using TeleService, you can work in the plant as usual with Micro/WIN.

This assumes you have correctly set the access point of the application beforehand.

Proceed as follows:

1. Open the "Set PG/PC Interface" dialog box with the menu command **Options > Set PG/PC Interface**.
2. Set the access point of the "Micro/WIN" application to the "TS Adapter" or "TS Adapter IE" interface.

Use the "TS Adapter" interface for connections via a TS Adapter I/II and the "TS Adapter IE" interface for connections via a TS Adapter IE.

Note

- Ensure that the "Access point of your application", "Micro/WIN" in this case, is assigned the correct interface.
 - If the access point is set to the "TS Adapter" interface, for example, because you are currently accessing a plant with a TS Adapter I or II, the access point must be reset to the "TS Adapter IE" interface before accessing a plant with a TS Adapter IE.
-

7.4 Displaying the Properties of a Remote Connection

Requirements

Once you have established a remote connection to a plant, you can then display the properties of this active connection.

Proceed as follows:

1. Select the **Connection > Current Connection** menu command or click on the appropriate button in the toolbar.
2. The "Current Connection" dialog box with the data for the active connection then opens. You cannot edit the properties.
3. Click on the "Close" button if you want to close this dialog box.

7.5 Disconnecting a Remote Connection

You have several means of disconnecting an active remote connection.

Proceed as follows:

Disconnect the active remote connection by:

1. Selecting the **Connection > Disconnect** menu command or by clicking on the appropriate button in the toolbar. The link is disconnected immediately.
2. Closing the window that contains the plant to which the remote connection exists. A prompt message asks you whether you really want to disconnect the link. Confirm by clicking on "OK".

The "OFFLINE" status is redisplayed in the status bar once the remote connection has been disconnected.

Note

You should switch to offline in STEP 7 before you disconnect the remote connection.

7.6 Checklist for Troubleshooting the Modem

The following list should help if you experience problems with the modem by identifying potential causes. The settings that need to be made and the dialog boxes where they are made are described in the help topics below.

Cannot make a modem connection:

- Check the cable and the connectors.
- Have you set the correct dialing mode (tone/pulse)?
- If your modem no longer responds after a few unsuccessful dialing attempts, a dialing blocker may be activated. Inform yourself about how dial blocking is implemented in your modem.
- Are you operating your modem on a main phone line or on an extension line? Configure the properties and dialing parameters of the modem accordingly.
- Enable the log file option in the advanced properties. The next attempt to establish a connection will then be recorded in a file in the Windows directory.
- Ensure that the employed ISDN-TAs are working with the same B and D channel protocols.

The modem connection breaks:

- Metering pulses can have a negative affect on a connection. Have the pulse deactivated by your phone company.
- Set fixed monitoring times.
- Deactivate the option that disconnects an existing connection automatically after a specified time without data transfer (idle).
- Ensure that you have activated the RTS/CTS protocol for data flow control.

8 Establishing Connections from Remote Plants (PG-AS Remote Connection)

8.1 Accessing Programming Devices/Personal Computers from Remote Plants

You can use the TeleService application and a TS Adapter I/II to establish a remote connection to a remote plant and thus to communicate with this plant. The initiative for establishing the remote connection comes from the programming device/personal computer.

However, events which require rapid intervention often occur at a remote plant. In such cases, when an asynchronous event occurs, the automation system can initiate a remote connection to a programming device / personal computer.

The following figure shows a graphical representation of the components which are required to establish a connection from a plant to a programming device / personal computer.

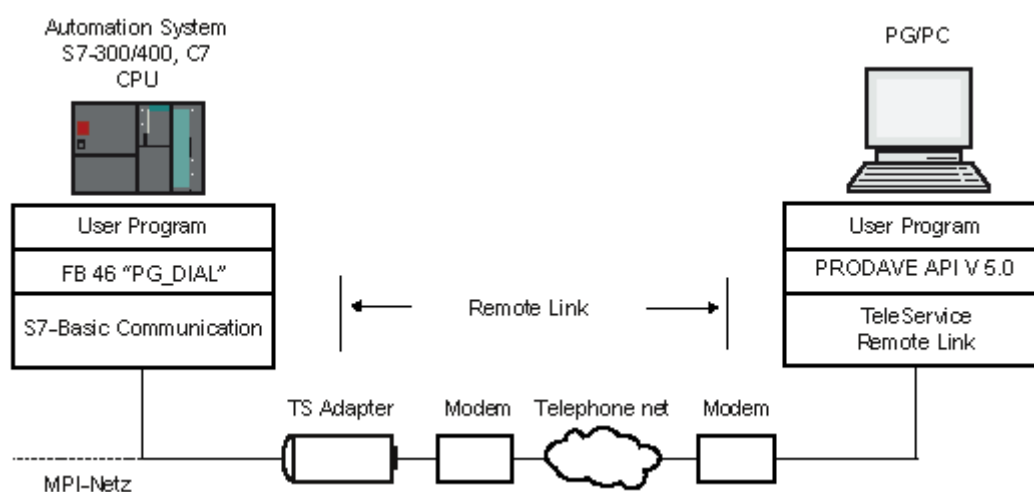

Note

You can find additional information on this in the help for the TeleService S7 Library.

8.2 Requirements for Establishing a Connection

Certain hardware and software requirements have to be fulfilled if it has to be possible for a remote plant to establish a remote connection to a programming device / personal computer. These requirements are described below.

Hardware Requirements:

In order to establish a remote connection you do not require any additional hardware to that also needed to access the remote plant from the programming device / personal computer.

In order to establish a connection your application program calls up a function block. This FB can only be executed on an S7-300 or S7-400 CPU on which the S7 basic communication is implemented.

The TS Adapter I with version 5.0 or a later version or a TS Adapter II must be used.

Software Requirements at the Plant End:

The scope of delivery of TeleService includes the FB 46 "PG_DIAL" function block which is included in the library of STEP 7 when the TeleService S7 library is installed. If a remote plant is to establish a remote connection to a programming device / personal computer, the application program of the plant has to call up the FB 46 "PG_DIAL" function block.

Software Requirements on the Programming Device / Personal Computer

You require a software component of the programming device / personal computer which together with TeleService waits for the call of a remote plant, recognizes it and informs your application program. In the first stage this functionality is implemented by the product PRODAVE MPI.

Your application program interfaces with the interface provided by PRODAVE MPI. PRODAVE MPI allows you not only to accept calls, but also to establish remote connections. For detailed information on its functionality as well as on the interface description please refer to the product description of PRODAVE MPI V5.0 (or later).

9 Data Communication between Remote Plants (AS-AS Remote Connection)

9.1 Overview of AS-AS Remote Link

The AS-AS (PLC) remote link allows two S7 automation systems to exchange process data via the phone network. The S7 automation system from which the initiative for establishing and disconnecting the remote link is designated as the **local** one below. The automation system to which the remote link is to be established is designated as the **remote** one.

The data exchange is carried out with the communication SFCs for non-configured S7 connections.

- SFC 65 "X_SEND",
- SFC 66 "X_RCV" ,
- SFC 67 "X_GET" and
- SFC 68 "X_PUT".

These SFCs are also called communication SFCs in this document.

The following figure shows a graphics representation of the components which are required to establish the connection from a local to a remote automation system.

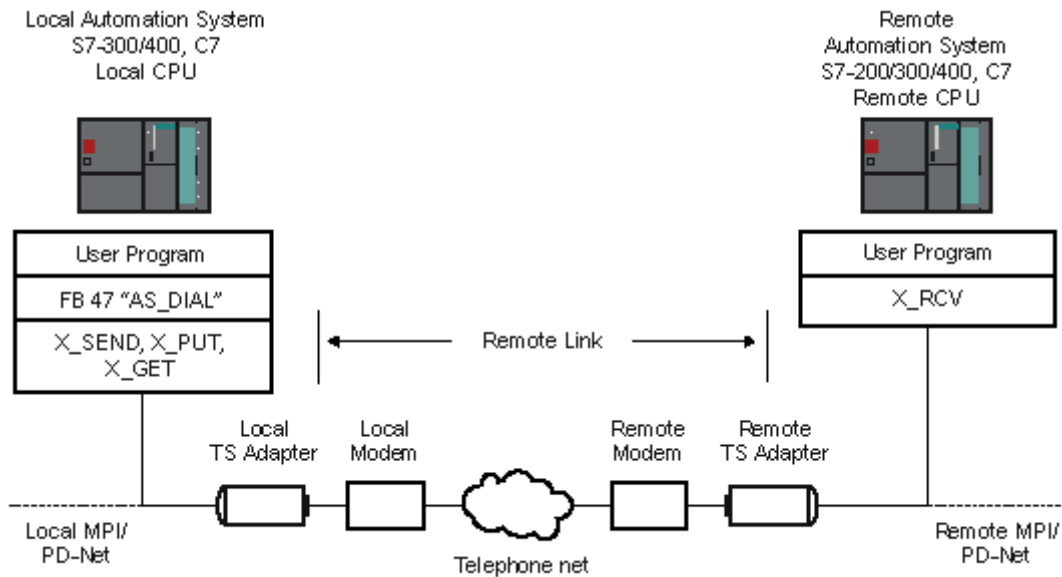

If the removed CPU is an S7-200, only X_GET and X_PUT can be called on the local automation system. X_GET and X_PUT are basic functions of the removed S7-200 CPU which are available without any further programming.

Note

You can find additional information about this in the help for the TeleService S7 Library.

9.2 Hardware and Software Requirements for AS-AS Remote Link

Certain hardware and software requirements have to be fulfilled so that a local automation system can establish a remote connection to a remote automation system. These requirements are described below.

Hardware Requirements

In order to transfer process data from a local to a remote automation system you do not require any additional hardware to that also needed to access the respective automation system from the programming device / personal computer.

To establish and disconnect the remote connection, the STEP 7 user program of the local CPU calls a function block. This FB can be executed on an S7-300/400 CPU or also C7 CPU. The function block assumes that the S7 Basic communication is implemented on the CPU. The remote CPU must also support S7 Basic communication.

A TS Adapter I with a version equal to or greater than V5.1 or a TS Adapter II must be used.

Software Requirements

The TeleService product includes FB 47 "AS_DIAL" function block that is included in the library of STEP 7 when the TeleService S7 library is installed. In order to establish and disconnect a remote connection from a local automation system to a remote automation system the "AS_DIAL" function block must be called up in your STEP 7 user program of the local CPU.

AS- AS- Remote connection

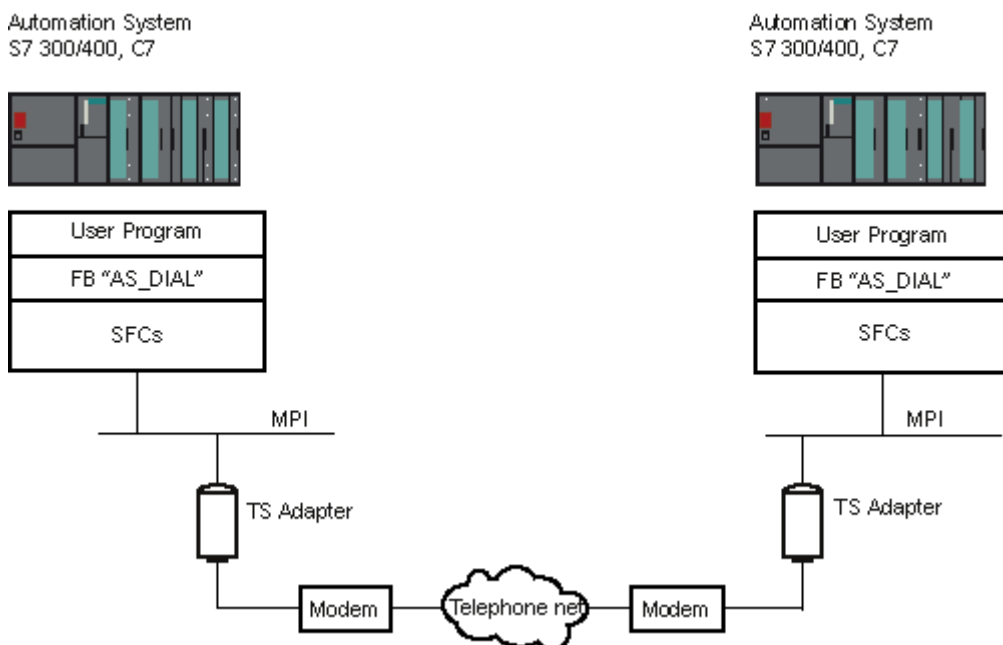

10 Sending Messages from a Plant (Sending SMS)

10.1 Requirements for Sending an SMS

If a plant is to send an SMS, certain hardware and software requirements must be fulfilled. These requirements are described below.

Hardware Requirements:

To send an SMS from a plant, you require a GSM radio modem and a TS adapter. A TS Adapter I with a version equal to or greater than V5.2 or a TS Adapter II must be used.

Software Requirements at the Plant End:

The function block FB 48 "SMS_SEND" is supplied with the TeleService product and is entered into the STEP 7 library when the TeleService S7 library is installed. If a plant is to send an SMS, the user program of the plant must call the FB 48 "SMS_SEND" function block.

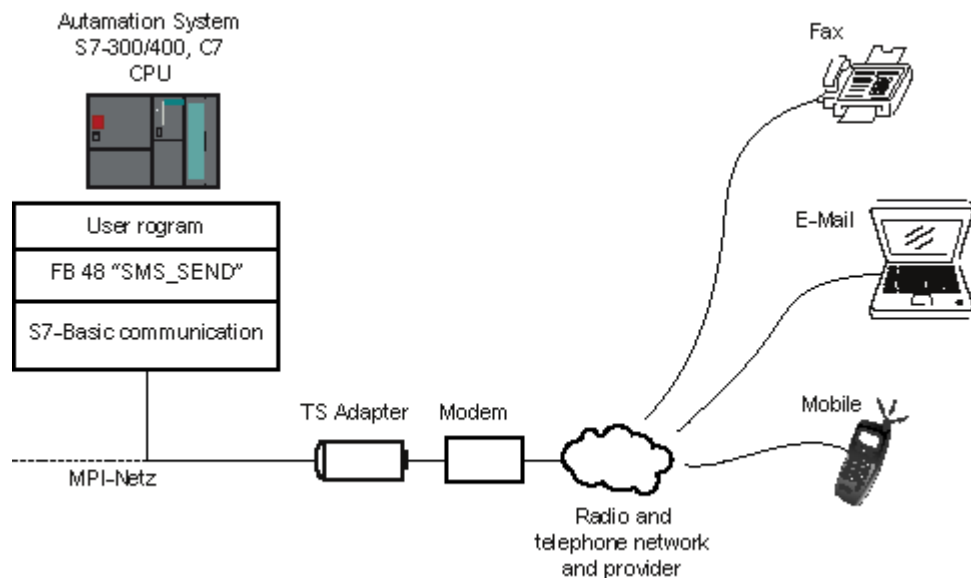

Note

You can find additional information about this in the help for the TeleService S7 Library.

11 Sending E-mail

11.1 Requirements for Sending E-mail

If a plant should send e-mail, the following hardware and software requirements must be fulfilled:

Hardware Requirements

To send e-mail from a plant, you need a TS Adapter IE and a CPU 31x-2 PN/DP as of firmware version V2.5 or a CPU 41x-3 PN/DP.

Software Requirements at the Plant End

Function block FB 49 "AS_Mail" is included in the TeleService package and is copied into the STEP 7 library during the installation of the TeleService S7 Library.

If a plant should send e-mail, the user program of the plant must call the FB 49 "AS_MAIL" function block. This uses the Simple Mail Transfer Protocol (SMTP) to send e-mail from a CPU to a mail server.

You also need the program blocks from the standard library of STEP 7 described below.

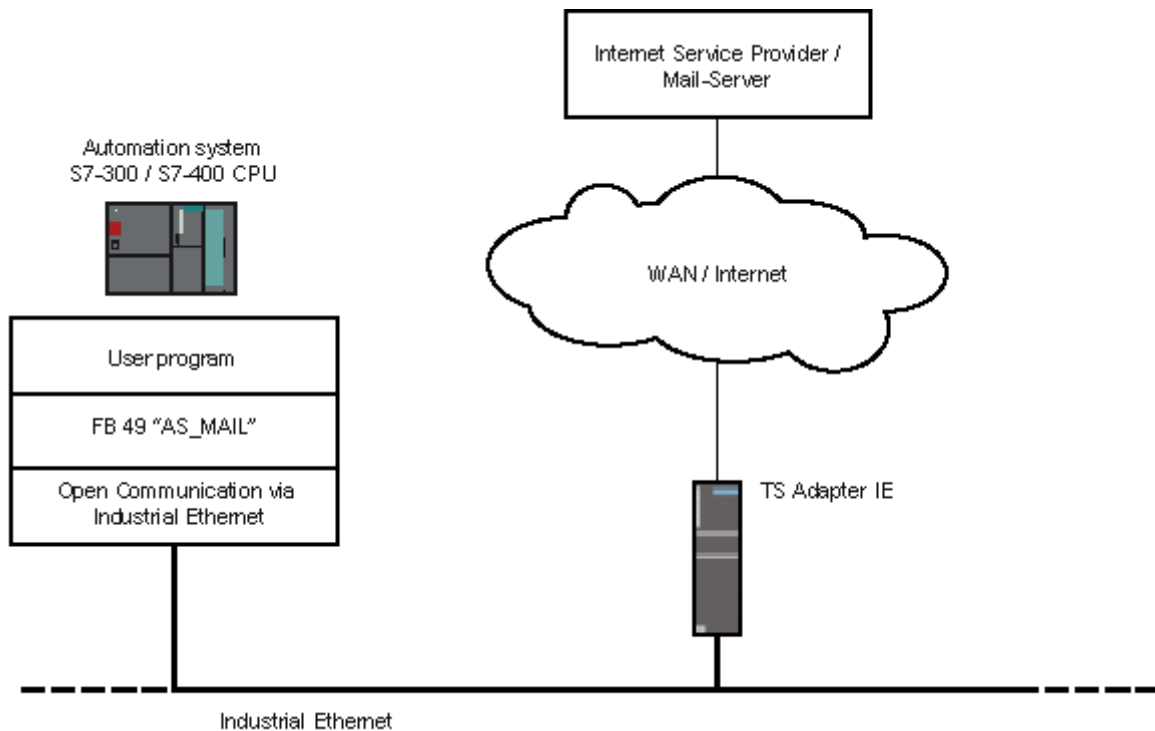

In addition, the "Use gateway / router" property must be set for the Ethernet interface in the configuration of the CPU on which FB 49 "AS_MAIL" is executed. (This is found under: Hardware Configuration > PROFINET IO (PN-IO) > General > Properties > Parameters). The IP address of the Ethernet interface of the TS Adapter IE should be specified as the "Address".

Required Program Blocks

FB 49 "AS_MAIL" requires the following FCs from the standard library of STEP 7 in the "IEC Function Blocks" folder:

- FC 10 "EQ_STRNG",
- FC 11 "FIND",
- FC 17 "INSERT",
- FC 20 "LEFT",
- FC 21 "LEN" and
- FC 32 "RIGHT".

You need to copy these blocks from the standard library of STEP 7 into your project and to your CPU.

Note

You can find additional information about this in the help for the TeleService S7 Library.

12 Managing Plant Data in Phone Books

12.1 Creating and Managing Phone Books

12.1.1 Creating Phone Books

Proceed as follows:

1. Select the **Phone Book > New** menu command or click the appropriate button in the toolbar. The "New Phone Book" dialog box then opens.

Note

Phone books are created by default in the directory in which you installed TeleService. However, you can also save phone books in a different directory.

2. Enter a name for the new phone book.
3. Confirm with "Save". The phone book is created.

Result:

You can now create folders in the new phone book. You save the data for the various plants in these folders.

12.1.2 Opening Phone Books

Proceed as follows:

1. Select the **Phone Book > Open** menu command or click the appropriate button in the toolbar. The "Open" dialog box is opened.
2. Select the number of the phone book that you wish to open.
3. Confirm by clicking on "Open".

The phone book is opened so that you can edit the folders and plant data contained in it.

Note

- TeleService can open phone books that were created with a TeleService version prior to V6.1 but it cannot save them. These "old" phone books must be first converted to the new format.
 - TeleService allows simultaneous access to a shared phone book by multiple users and warns users before overwriting modified phone books. The warning is given when the saving a modified phone book and the system detects that the change time stamp of the modified phone book no longer matches the time stamp of the book when it was first opened.
-

12.1.3 Saving Phone Books

You can save a phone book either under the current name or under a new name.

To save under the existing name:

- Select the **Phone Book > Save** menu command or click the appropriate button in the toolbar. The phone book is saved under its current name.

To save under a new name:

1. Select the **Phone Book > Save As** menu command. The "Save As" dialog box is opened.
2. Enter the name under which you wish to save the phone book.
3. Confirm with "Save". The phone book is saved under the new name.

12.1.4 Specifying the Page Format for Printing

In TeleService you can set the page format for the printout of a phone book, a folder or a plant

Proceed as follows:

- Select the **Phone Book > Page Setup** menu command. The "Page Setup" dialog box is opened.
- Select the desired options for your printout.
- Confirm your entries with "OK".

Note

- If you click on the "Headers/Footers" button, a dialog box is displayed where you can define the headers and footers for the printout.
 - The selected settings can be checked in the page preview by using the **Phone Book > Print Preview** menu command.
-

12.1.5 Displaying the Print Preview

You can check in the print preview the print setup that you have defined for a specific phone book, folder, or plant before it is actually printed.

Proceed as follows:

1. Open or select the phone book to be printed.
2. Select the **Phone Book > Print Preview** menu command. The print setup is then displayed in the page view.

Note

If the printout has more than one page, an identifier is printed after the page number at the bottom right corner of the page to indicate that there is another page. The last page does not have this symbol, indicating that no more pages are to follow.

12.1.6 Printing Phone Books

You can print either the complete data of a phone book or just a specific part of a phone book.

Proceed as follows:

1. Select the number of the phone book that you wish to print.
2. Select the **Phone Book > Print** menu command or click on the appropriate button in the toolbar. The Print" dialog box is opened.
3. Specify here whether you wish to print the complete phone book or just part of the phone book and set all other options.
4. Start the print job with "OK".

Result:

The phone book data is printed on the default printer. If the printout has more than one page, an identifier is printed after the page number at the bottom right corner of the page to indicate that there is another page. The last page does not have this symbol, indicating that no more pages are to follow.

Note

You use the **Phone Book > Print Setup** menu command to set the printer and the further print options.

12.2 Creating and Editing Folders

12.2.1 Creating Folders

You can create several folders in a flat hierarchy in a phone book.

Proceed as follows:

1. Select the **Insert > Folder** menu command or click with the right-hand mouse button and select the "New Folder" command.
2. Name the created folder and confirm with RETURN.

12.2.2 Cutting Folders

You can cut out a folder and paste it at another location, for example, in another phone book.

Proceed as follows:

1. Select the folder that you wish to cut out.
2. Select the **Edit > Cut** menu command or click on the appropriate button in the toolbar, or click the right-hand mouse button and select the "Cut" command.

Result: The folder is then stored in the clipboard from where you can paste it at any location.

12.2.3 Copying Folders

You can copy a folder and insert it at another location, for example, in another phone book.

Proceed as follows:

1. Select the folder that you wish to copy.
2. Select the **Edit > Copy** menu command or click on the appropriate button in the toolbar, or click the right-hand mouse button and select the "Copy" command.

The folder is then stored in the clipboard from where you can paste it at any location.

12.2.4 Pasting Folders

You can paste a folder contained in the clipboard at any location.

Proceed as follows:

1. Select the location at which you wish to paste the folder.
2. Select the **Edit > Paste** menu command or click on the appropriate button in the toolbar, or click the right-hand mouse button and select the "Paste" command.

The folder is then inserted at the selected location.

12.2.5 Renaming Folders

You can assign a new name to an existing folder.

Proceed as follows:

1. Select the folder that you wish to rename.
2. Select the **Edit > Rename** menu command or click with the right-hand mouse button and select the "Rename" command.
3. Enter the new name and terminate with RETURN.

The folder is then displayed with its new name.

12.2.6 Deleting Folders

If you delete a folder, all the plant data contained in it is also deleted.

Proceed as follows:

1. Select the folder that you wish to delete.
2. Select the **Edit > Delete** menu command or click with the right-hand mouse button and select the "Delete" command.

The folder including the plants is then deleted from the phone book.

12.2.7 Printing Folders

You can print the data for a specific folder.

Proceed as follows:

1. Select the folder that you wish to print.
2. Click the right-hand mouse button and select the "Print" command. The Print" dialog box is opened.
3. Set the required options in the "Print" dialog box.
4. Start the print job with "OK".

Result:

The folder data is output at the default printer. If the printout has more than one page, an identifier is printed after the page number at the bottom right corner of the page to indicate that there is another page. The last page does not have these periods, indicating that no more pages are to follow.

Information

You use the **Phone Book > Print Setup** menu command to set the printer and the print options.

12.3 Creating and Editing Plants

12.3.1 Creating Plants

You can create several plants in a folder of a phone book to save data.

Proceed as follows:

1. Call the "Insert New Plant" dialog box by:
Selecting the **Insert > Plant** menu command or selecting a plant and then using the right-hand mouse button to select the "New Plant" command.
2. Enter the appropriate data for the plant in the "Plant" tab. You have to specify the "Name" field and can enter data on the phone connection immediately or afterwards. All other fields are optional.
3. You can enter a comment on the plant in the "Comment" tab.
4. Confirm your entries with "OK".

The plant is then created in the appropriate folder.

12.3.2 Changing Plant Data

Existing plant data can be changed at any time.

Proceed as follows:

1. Select the plant whose data you want to change.
2. Select the **Edit > Object Properties** menu command or click with the right-hand mouse button and select the "Object Properties" command. The "Plant Properties" dialog box then opens.
3. Change the required plant data in the "Plant Data" tab. The "Name" field and the phone number fields must contain data. All other fields are optional.
4. You can edit a comment on the plant in the "Comment" tab.
5. Confirm your changes with "OK".

12.3.3 Cutting Plants

You can cut out a plant and insert it at another location, for example, in another folder.

Proceed as follows:

1. Select the plant that you wish to cut out.
2. Select the **Edit > Cut** menu command or click on the appropriate button in the toolbar, or click the right-hand mouse button and select the "Cut" command.
3. The plant is then stored in the clipboard from where you can paste it at any location.

12.3.4 Copying Plants

You can copy a plant and insert it at another location, for example, in another folder.

Proceed as follows:

1. Select the plant that you wish to copy.
2. Select the **Edit > Copy** menu command or click on the appropriate button in the toolbar, or click the right-hand mouse button and select the "Copy" command.
3. The plant is then stored in the clipboard from where you can paste it at any location.

12.3.5 Pasting Plants

You can paste a plant contained in the clipboard at any location.

Proceed as follows:

1. Select the location at which you wish to paste the plant.
2. Select the **Edit > Paste** menu command or click on the appropriate button in the toolbar, or click the right-hand mouse button and select the "Paste" command.
3. The plant is then inserted at the selected location.

12.3.6 Deleting Plants

If you delete a plant, all the plant data contained in it are also deleted.

Proceed as follows:

1. Select the plant that you wish to delete.
2. Select the **Edit > Delete** menu command or click with the right-hand mouse button and select the "Delete" command.
3. The plant including all the data is deleted from the phone book.

12.3.7 Printing Plants

You can print the data for a specific plant.

Proceed as follows:

1. Select the plant that you wish to print.
2. Click the right-hand mouse button and select the "Print" command. The "Print" dialog box is opened.
3. Set the required options in the "Print" dialog box.
4. Start the print job with "OK".

Result:

The plant data are output at the default printer. If the printout has more than one page, two periods are printed after the page number in the bottom right corner of the page. The last page does not have these periods, indicating that no more pages are to follow.

Information

You use the **Phone Book > Print Setup** menu command to set the printer and the print options.

13 Troubleshooting

13.1 General Information on Troubleshooting

The cause of modem problems can often be found more easily by remembering the two following points:

1. Activate the recording function for a log file for recording the data traffic between the programming device/personal computer and the modem. The entries in this file can provide valuable information for determining the cause of errors.
2. Switch on the loudspeaker at your local modem. Select a volume which is loud enough to be heard well.

You can then hear whether:

- There is a dial tone at the connection,
- The called modem is busy or
- The called modem accepts the call.

Common Modem Problems

The most common modem problems include:

- Modem connection is not established
- Modem connection is interrupted

The sections below contain tables which describe common causes and provide information on eliminating the respective fault or error.

13.2 Recording a Log File

Procedure

Activate the properties dialog box of the modem used via the Control Panel, "Phone and Modem Options" option. Check the settings of the "Log" option in the "Diagnostics" tab and change the settings for the log file, if necessary.

Result:

The activities between the programming device/personal computer and the modem are entered in the log file. If there are problems in establishing the connection, you can evaluate the recordings in the log file in order to find the causes for the fault.

13.3 Remote Connection to the TS Adapter is not Established

Error:	Possible cause:	Check / Remedy:
Remote connection is not established	Cabling faulty	<ul style="list-style-type: none"> • Are all the connecting cables connected correctly? • Are the connectors loose?
	Dial parameters for main connection and extension set incorrectly	<ul style="list-style-type: none"> • Are the set properties and dial parameters of the modem suitable for the phone connection (main connection or extension)? • If you operate your modem on a main connection, you must not specify an access code in the "Dial parameters" dialog box. The fields for the access code for local calls and remote calls have to be empty.
	Dialing process set correctly	<ul style="list-style-type: none"> • Is the correct dialing method (tone/pulse) set in the dialog box for the dial parameters of your modem? • Use a connected phone to check the connection on which you want to operate the modem. During pulse dialing you should be able to hear crackling noises. During tone dialing you should hear noises with varying tone heights. Set the corresponding dialing process at the modem dial parameters.
	Dial disable active	<ul style="list-style-type: none"> • The dial disable function is modem property specified country-specifically, which, depending on the modem, comes into action after one or more attempts to establish a connection. • If your modem does not react after several attempts to dial, the dial disable function may be active. After the dial command characters are sent to the modem, but the modem does not start the dialing process. The driver receives a general error message. • Refer to the modem documentation for information on how the dial disable function is implemented for your modem. • Make sure that a log file (modemlog.txt) is created in which the activities between the programming device/personal computer and modem are recorded. Then check whether the file contains an entry caused by the dial disable (for example, DELAYED).

Error:	Possible cause:	Check / Remedy:
Remote connection is not established	Phone connection defective or busy	<ul style="list-style-type: none"> • Connect a phone and check whether a dial tone can be heard on this connection. • If an analog phone is connected on the same connection, it must be hung up. You cannot establish an additional modem connection on this connection if there is an existing phone connection.
	Serial parameters set incorrectly	<ul style="list-style-type: none"> • Are the correct values entered in the "Settings" tab of the modem properties (8 data bits, no parity, 1 stop bit)? • Is the correct COM interface set in the "General" tab of the modem properties?
	Initialization string of the TS Adapters is not suitable for the modem	<ul style="list-style-type: none"> • Set the modem initialization string in accordance with the following requirements: <ul style="list-style-type: none"> - Properties of the Modem Initialization String for TS Adapter I/II - Procedure for Configuring the TS Adapter IE
	Setting for error correction between the modem at the TS Adapter and the modem at the PC/programming device are not compatible	<ul style="list-style-type: none"> • Adapt the modem settings. • Useful Information on Configuring the TS Adapter I/II • Restoring the Default Configuration of a TS Adapter I/II • Procedure for Configuring the TS Adapter IE

13.4 Remote Connection from the TS Adapter is not Established

Error:	Possible cause:	Check / Remedy:
Callback from TS Adapter not carried out:	Location or call settings in the TS Adapter are incorrect	<ul style="list-style-type: none"> • Check the configuration of the TS Adapter: • Are the dialing method and access code set to suit the phone connection? • Does the modem at the TS Adapter support the characters configured for the access code? • Is "Wait for dial tone before dialing" deactivated at an extension?
	Initialization of the modem insufficient	<ul style="list-style-type: none"> • Check the string for initializing the modem. The modem may require a further initialization in order to establish a remote connection. • Properties of the Modem Initialization String for the TS Adapter I/II
	Callback number is incorrect	<ul style="list-style-type: none"> • Check the configuration of the callback number you assigned.
Call from TS Adapter not carried out:	Phone number is incorrect	<ul style="list-style-type: none"> • Is the desired number being transferred to the FB "PG_DIAL"?
	Configuration of the TS Adapter is incorrect	<ul style="list-style-type: none"> • Check the configuration of the TS Adapter I/II: • Are the dialing method and access code set to suit the phone connection? • Does the modem at the TS Adapter I/II support the characters configured for the access code? • Is "Wait for dial tone before dialing" deactivated at an extension?

13.5 Modem Connection is Interrupted

Error:	Possible cause:	Check / Remedy:
Modem connection is interrupted:	Metering pulse in the line	<ul style="list-style-type: none"> • If you have applied for a metering clock at the phone company, metering pulses are generated. This may mean that the modem no longer recognizes the carrier signal and switches off. • Set a longer waiting or disconnecting time at the modem. • Have the metering pulse deactivated by the phone company.
	Shielding	<ul style="list-style-type: none"> • Are the connection cables used shielded sufficiently? • Make sure that the modem cables do not run next to power cables and that they are at the greatest possible distance from power supply units and monitors.
	Protocol timeouts	<ul style="list-style-type: none"> • Set fixed monitoring times.
	Automatic connection disconnection	<ul style="list-style-type: none"> • Deactivate the option that disconnects an existing connection automatically after a specified time without data transfer ("Disconnect after no data transfer of ..."). <ul style="list-style-type: none"> - Useful Information on Setting Modem Properties - Setting the TeleService-specific Modem Properties
	Data flow control deactivated	<ul style="list-style-type: none"> • Click on the "Extended" button in the "Settings" tab of the modem properties and activate the following options in the displayed dialog box (if offered and not yet set): <ul style="list-style-type: none"> - Data flow control, - Hardware (RTS/CTS), - Data compression, - Error control
	Initialization string of the TS Adapters is not suitable for the modem	<ul style="list-style-type: none"> • Set the modem initialization string in accordance with the following requirements: <ul style="list-style-type: none"> - Properties of the Modem Initialization String for the TS Adapter I/II - Procedure for Configuring the TS Adapter IE

13.6 Modem Messages

The modem messages are entered in a log file if you have activated the recording function.

Message:	Possible cause:	To Correct or Avoid Error:
NO DIALTONE	It is possible that a phone call is being carried out on this line.	<ul style="list-style-type: none"> Repeat the process when the phone call has been terminated.
NO CARRIER	The user dialed is not ready, is not a modem or cannot establish a connection with the set operating mode.	<ul style="list-style-type: none"> Check the numbers and the settings.
BUSY	The user dialed is busy.	<ul style="list-style-type: none"> Try again later.
DELAYED: ...	Dial disable	<ul style="list-style-type: none"> Refer to the modem documentation for information on how the dial disable function is implemented for your modem.

Glossary

Access Rights for the TS Adapter I/II

In case of a modem connection only the administrator may set up the two users, can change their settings and also delete them again, if required. If you log in as a user, you can only change your own password and your own callback number. All other parameters of the TS Adapter I/II are only displayed and cannot be changed.

Acknowledgment Monitoring Time

The acknowledgment monitoring time or also the acknowledgment delay time is used to monitor the arrival of a procedural acknowledgment from the driver.

B Channel Protocol

B channel protocols are used during data transfer between ISDN terminal devices.

The ISDN adapter contained in the TS Adapter II-ISDN supports the protocols X.75, V.110 and V.120.

A connection is only established if both ISDN terminal devices operate with the same B channel protocol.

You can set the corresponding B channel protocol in the "Internal ISDN-TA" dialog box.

Callback Number (Definition)

If a callback number is specified for establishing a connection or a callback number is stored in the TS Adapter, the modem connection is disconnected after the login and the TS Adapter then calls the callback number.

CAPI

Common Application Programming Interface: Interface which can access ISDN devices via programs.

Character Monitoring Time

The character transfer time is used to monitor the arrival of characters in the data transfer phase.

D Channel Protocol

D channel protocols are used for ISDN network services. The ISDN network point and the ISDN adapter connected to it have to use the same protocol.

Various D channel protocols are available:

- For example, the protocols DSS1 and 1TR6 are used in Europe
- For example, the protocols NI1, 5ESS and DMS100 are used in North America.
- You can set the corresponding D channel protocol in the "Internal ISDN-TA" dialog box.

Data Flow Control

During the course of a connection the data flow has to be stopped briefly if, for example, the modem buffer is full. There are two possibilities for controlling the data flow:

- Software protocol XON/XOFF
- Hardware protocol RTS/CTS

In the software protocol one of the connected devices sends an XOFF control character when it is no longer possible able to take up further data. The sending device then waits with the transfer until the receiving device sends an XON control character.

In the hardware protocol RTS and CTS are changed over at the serial interface in order to interrupt the signals of the RS232 control cables.

As a rule both the modem-to-modem flow control and the end-device-to-end-device flow control can be set with the Hayes command set.

DCD

Data Carrier Detect: RS232 interface circuit which becomes active (ON) when a remote connection is established.

DCE

Data Carrier Equipment: Data circuit-terminating equipment: Modem

Dialing Method

Set the dialing method (tone or pulse dialing) common for your phone connection. During pulse dialing you hear crackling noises. During tone dialing you hear noises with varying tone heights.

Direct Connection (Definition)

In the case of a direct connection there is a direct connection between the programming device/personal computer on which TeleService is installed and the automation system via the TS Adapter. No modem is required to this purpose. The direct connection is used essentially to configure the TS Adapter.

With the TS Adapter I, the direct connection is over the serial port; the TS Adapter II uses the Universal Serial Bus (USB) and the TS Adapter IE uses Industrial Ethernet.

Folder

Folders are used in TeleService to manage plants in which specific data on establishing remote connections are saved. Folders are managed in phone books.

GSM

Global System for Mobile Communication.

Initialization String (Definition)

The initialization string is a string consisting of AT commands (quasi-standard commands for modems) with which the modem connected to the TS Adapter is initialized.

Interface Speed

The interface speed is the speed with which the data are transferred between two devices, for example between the modem and the TS Adapter.

ISDN

Integrated Services Digital Network: Service of a service provider for the digital transfer of data and speech.

ISDN Adapter

An ISDN adapter (or ISDN terminal adapter, ISDN-TA) is an ISDN device which is connected to a serial PC/programming device interface in order to transfer data via the digital network.

ISDN Modem

An ISDN modem (**Modulator/Demodulator**) is an ISDN adapter with integrated analog modem functionality.

Logon Data (definition)

A remote connection to a TS Adapter can only be successfully established if the specified logon data (user name and password) for establishing a connection matches the logon data stored in the TS Adapter.

Modem (Definition)

Modulator/Demodulator: A modem is a communication device that allows a computer to send and receive data via phone lines.

It converts digital pulses of the computer into analog signals and vice versa.

Modem Connection

In the case of a modem connection, the connection between the programming device or PC on which the TeleService is installed and the automation system onto whose MPI/DP or Ethernet interface of the TS Adapter is plugged is implemented via a modem connection. By this means the programming device/personal computer is connected to the MPI/PROFIBUS network or Industrial Ethernet of the automation system via the remote connection and the TS Adapter. The modem connection is the usual configuration for working with the TeleService.

Multiple subscriber number (MSN)

If more than one terminal device (e.g. an ISDN phone and a TS Adapter II with an integrated ISDN adapter) is connected to an ISDN multiple terminal connection with the D-channel protocol DSS1 or 1TR6, you have to assign different multiple subscriber numbers to these terminal devices.

Example: Two multiple subscriber numbers are available at one multiple terminal connection:

- "121212" and
- "141414".

The ISDN phone should only react to calls for the number "121212" and the number "141414" is reserved for a TS Adapter II ISDN. In order for the TS Adapter II ISDN to only accept calls for the number "141414", set "DSS1, 1TR6" as the D-channel protocol in the "Internal ISDN-TA" dialog box. Additionally enter the number "141414" in the "Multiple Subscriber Number" box.

If the multiple subscriber numbers are not entered, the integrated ISDN adapter accepts all the calls.

Password

After a modem connection has been established the administrator or the users have to enter a password during logging in.

PG_DIAL

The function block FB 46 "PG_DIAL" transfers a phone number and a freely assignable event ID for error identification or for identifying a message number to a TS Adapter.

Phone Book

Phone books are used in TeleService to manage the plant data. Phone books are the highest hierarchic level. They contain folders in which plants with specific data for establishing remote connections are saved.

Plant

Plants contain plant-specific data for establishing remote connections. Plants are located in folders, which in turn are managed in phone books.

Remote Connection (Remote Link)

A remote connection is an asynchronous connection build-up from a plant to a programming device/personal computer. The call is initiated by calling the function block 46 "PG_DIAL".

A remote connection / remote maintenance occurs when you use TeleService to access a remote plant via the telephone network. The PG/ PC is connected to the telephone network via a modem for this. The automation system at the other end is connected to the telephone network via a configured TS Adapter and a modem. You can use the remote connection to modify the selected plant as usual with STEP 7 (remote maintenance).

Remote Connection

A remote connection (link)/teleservice connection arises when you use TeleService to dial into a remote plant via a phone network. To this purpose the programming device/personal computer with TeleService connected via a modem to the phone network. At the other end the automation system is connected via a configured TS Adapter and a modem to the phone line. A remote connection makes it possible to edit the dialed plant as usual with STEP 7 (teleservicing).

Requirements Placed on the Initialization String

The following properties have to be specified in the string for initializing the modem:

- The modem provides feedback messages.
- The feedback is output in clear text.
- The DCD signal is only activated when a connection exists.
- The transfer speed between the TS Adapter and the modem is not changed after the connection has been established.
- The RTS/CTS protocol is active as a flow control between the TS Adapter and the programming device or PC respectively.
- The automatic call acceptance by the modem is activated.

Safety Function for MPI/PROFIBUS Interfaces

If you activate an online function on your programming device/personal computer without a safety function, the interface begins to send messages. If you connect the interface to a network at such a moment, it is disturbed briefly by the messages. This can lead to network connections being disconnected.

A safety function is therefore normally activated at the communication drivers:

- The interface can only send messages, if messages (from other masters) have been heard free of errors.
- If it was not possible to hear a message (free of errors), the driver outputs an error message.

A passive station (slave) can only send data if it is prompted to do so by active station (master). If you have connected only slaves to the programming device/personal computer, you must therefore deactivate this safety function by activating the "Programming device / PC is the only master on the bus" check box. If the "Programming device / PC is the only master on the bus" check box is deactivated and all further masters fail, communication is no longer possible from the programming device/personal computer to the slaves.

SMS

An SMS (**S**hort **M**essage **S**ervice) is a message of limited length (max. of 160 characters), which can be sent via a radio network to a GSM receiver.

Transfer Speed

The transfer speed is the rate at which data are transferred on the phone line. The transfer speed which can be reached is the main criterion for performance of a modem. The faster the data can be transferred, the lower the phone costs are.

TS Adapter (Definition)

The TS Adapter is used to connect an automation system via a modem to a phone network in prepare it for the use of TeleService.

The TS Adapter has a parameter memory in which various parameter records are stored for TeleService operation.

There are three versions of the TS Adapter:

- TS Adapter I
- TS Adapter II
- TS Adapter IE

In this Help system, the term "TS Adapter" stands for all versions. If an explanation is valid for a specific version only, this is pointed out and "TS Adapter I", "TS Adapter II" or "TS Adapter IE" is named explicitly.

Overview of the existing TS Adapters:

TS Adapter I:	
Direct connection over the serial port, Firmware cannot be replaced.	
Version:	Essential Expansions:
V3.0	-
V5.0	Access protection
V5.1	Access protection, network type AUTO
V5.2	Access protection, network type AUTO, sending SMS messages

TS Adapter II:
Direct connection over the Universal Serial Bus (USB). Replaceable firmware. Modem integrated or can be connected as external modem. The TS Adapter II switches automatically between the modems. As long as no external modem is connected, it uses the internal modem.
There are two variants:
<ul style="list-style-type: none"> • With an analog internal modem. An external modem can also be connected to the RS-232-port. • With an internal ISDN adapter.. An external modem can also be connected to the RS-232-port..

TS Adapter IE:
Direct connection over Industrial Ethernet (IE). Replaceable firmware. Modem integrated or can be connected as external modem. The TS Adapter IE cannot automatically switch between modems like the TS Adapter II. Configuration is performed in a Web interface.
There are two variants:
<ul style="list-style-type: none"> • With an analog internal modem. An external modem can also be connected to the RS-232-port. • With an internal ISDN adapter.. An external modem can also be connected to the RS-232-port..

Note

For more detailed information on the TS Adapter, refer to the documentation supplied with the TS Adapter.

Index

A

Access code 4-8
Access protection for the
 TS Adapter I/II 3-15
Accessing Programming Devices/Personal
 Computers from Remote Plants 8-1
Assigning IP parameters of the
 TS Adapter IE 6-1
Authorization diskette 2-6
Authorization program 2-6
Automatic call acceptance 5-5
Automation License Manager 2-3

C

Callback from TS Adapter
 not carried out 13-5
Calling from TeleService 3-1
Certificate of license 2-3
Changing Plant Data 12-8
Checklist for troubleshooting
 the modem 7-5
Clear text output of feedbacks 5-5
COM interface 3-7
COM port 3-11
Compatibility 1-5
Compatibility of TeleService V6.0
 with the TS adapter 1-5
Configuration options for the
 TS Adapter I/II 5-1
Connecting and Configuring the Remote
 Modem 2-10
Copying folders 12-5
Copying Plants 12-9
Creating folders 12-5
Creating Phone Books 12-1
Creating Plants 12-8
Cutting folders 12-5
Cutting plants 12-9

D

Data compression 13-6
DCD 5-5
Defining the location and the corresponding
 dial parameters 4-7
Deleting folders 12-6
Deleting Plants 12-10
Dial parameters 2-9, 4-7, 13-3
Dial pause 13-3
Direct connection 3-7, 3-9
Disconnecting a Remote Connection 7-4
Displaying the Print Preview 12-3
Displaying the Properties of a
 Remote Connection 7-4

E

Error control 13-6
Establishing a remote connection 7-1
Establishing a Remote Connection 7-1
Exporting adapter parameters for
 TS Adapter I/II 5-3
Extension 4-7, 13-3

F

Feedback 5-5
Flow control 5-5
Folder 1-7
Functionality of TeleService 1-2
Functionality of TeleService and required
 components 1-2

G

General information on
 troubleshooting 13-1
Getting started 1-7
Getting started with TeleService 1-7, 1-9

H

Hardware and Software Requirements 9-3
How the TS Adapter I/II Works 3-6
How the TS Adapter IE works 3-6

I

- Importing adapter parameters for
 TS Adapter I/II 5-4
- Information Functions in TeleService 3-19
- Initialization after Return of Power 5-6
- Installing a local modem
 under Windows 2-9
- Installing authorizations 2-6
- Installing TeleService 2-1
- Installing the Automation License Manager
 2-6
- Installing the interfaces for the
 TS Adapter and TS Adapter IE 2-8
- Installing the Software for the
 TS Adapter 2-7
- Introduction 1-1
- Introduction to TeleService 1-1

L

- License 2-3, 2-4, 2-5
- License for use by the Automation License
 Manager 2-3
- License key 2-3, 2-4, 2-7
- License Manager 2-3, 2-4
- License types 2-5
 - enterprise license 2-3
 - floating license 2-3
 - rental license 2-3
 - single license 2-3
 - trial license 2-4, 2-5
 - upgrade license 2-3
- Local modem 2-9
- Local Parameters in TeleService 4-4
- Location 4-8
- Location or call settings in the
 TS Adapter are incorrect 13-5
- Log file 13-1

M

- Main connection 4-8, 13-3
- Menu bar 3-2
- Modem
 - Local 2-9
 - problems 7-5
- Modem cable 3-13
- Modem connection 3-8, 3-9
- Modem connection is interrupted
 - Data flow control 13-6
- Modem messages 13-7
- Modems with plug-and-play facilities 2-9
- Modems without plug-and-play facilities 2-9

N

- Network parameters 3-7
- New functions of TeleService V6.0 1-4

O

- Online connection 3-7
 - Disconnecting 7-4
 - Establishing 7-1
 - Properties 7-4
- Opening Phone Books 12-2
- Operating the TS Adapter with a direct
 connection 3-10
- Operating the TS Adapter with a modem
 connection 3-12
- Overview of AS-AS Remote Link 9-1
- Overview of Local and
 Remote Settings 4-1
- Overview of the options for configuring the
 TS Adapter I/II 5-1

P

- Page format 12-3
- Pasting folders 12-6
- Pasting plants 12-9
- Performance in phone networks 3-4
- Phone book 1-7
- Phone books folders and plants in
 TeleService 1-6
- Phone networks modems and data
 throughput 3-4
- Plant 1-6, 1-7
- Preset Modem Initialization String 5-5
- Print preview 12-3
- Printing folders 12-7
- Printing Phone Books 12-4
- Printing Plants 12-10
- Procedure for configuring the
 TS Adapter I/II 5-2
- Procedure for configuring the
 TS Adapter IE 6-1
- Programming device/personal computer
 interface 4-3
- Properties
 - Remote connection 7-4
- Properties of a remote connection 7-4
- Properties of the modem initialization string
 for TA Adapter I/II 5-5
- Pulse dialing 4-8

R

- Recording a Log File 13-2
- Remote connection from TS Adapter is not established 13-5
- Remote connection to the TS Adapter is not established 13-3
- Renaming folders 12-6
- Required components 1-2
- Requirements for Establishing a Connection 8-2
- Requirements for Sending an SMS 10-1
- Requirements for sending E-mail 11-1
- Restoring the default configuration of a TS Adapter I/II 5-4
- RTS/CTS 13-6
- RTS/CTS protocol 5-5
- Rules
 - for handling license keys 2-7
- Rules for handling license keys 2-7

S

- Saving Phone Books 12-2
- Separating a remote connection 7-4
- Setting the PG/PC interface 4-3
- Setting the general modem properties 4-6
- Setting the interface for a directly connected TS Adapter IE 6-2
- Setting the TeleService-specific modem properties 4-6
- Setting up access protection for TS Adapter I/II 5-3
- Specifying the page format for printing 12-3
- Starting TeleService 3-1
- Status bar 3-2
- STEP 7
 - Online connection 7-2, 7-3
- Switching between direct and modem connections with the TS Adapter I/II 5-2

T

- TeleService 2-1, 2-2
 - Installing 2-1

- TeleService logbook 3-18
- The user interface of TeleService 3-2
- Tips for modem problems 7-5
- Title bar 3-2
- Tone dialing 4-8
- Toolbar 3-2
- Troubleshooting 13-1, 13-7
- TS Adapter 2-7
 - access protection 3-15, 3-16
 - Installing 2-7
- TS Adapter IE
 - configuring 6-1

U

- Uninstalling
 - right to use products 2-7
- Useful information about TeleService logbook 3-18
- Useful information on access protection for the TS Adapter I/II 3-15
- Useful information on callback 3-17
- Useful information on configuring the TS Adapter I/II 5-1
- Useful Information on Setting Modem Properties 4-4
- User interface 3-2
- Using the remote connection with Micro/WIN 7-3
- Using the remote connection with STEP 7 7-3
- Using the remote connection with STEP 7 7-2
- Using the TS Adapter 3-7
- Using the TS Adapter for TeleService 3-7
- Using the TS Adapter with a direct connection 3-7
- Using the TS Adapter with a modem connection 3-7

W

- What's new in TeleService V6.0? 1-4
- Working with a TS Adapter I/II 1-7
- Working with a TS Adapter IE 1-9

