

Braking Resistors for MICROMASTER Vector Instruction Sheet

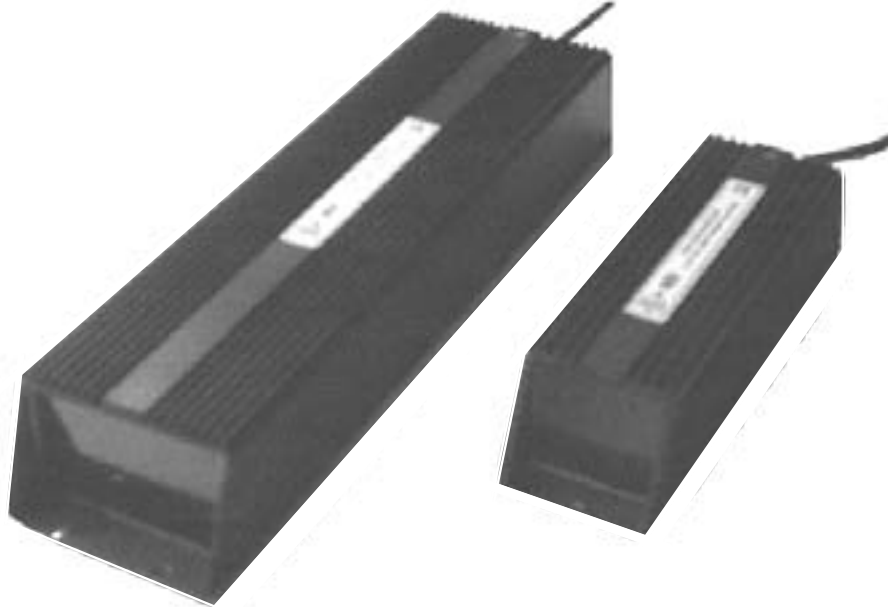

Safety Precautions

	WARNING
	Safe operation and performance to specification can only be guaranteed if this equipment is installed by suitably qualified personnel.
	All applicable installation, usage and safety regulations regarding high voltage installations must be complied with.
	If the inverter is already in use, disconnect the prime power and wait at least five minutes for the capacitors to discharge before commencing installation.
	This equipment must be earthed (IEC 536 Class 1).
	Braking resistors get hot during operation - do not touch . Provide adequate clearance and ventilation.
	A thermal cut-out circuit (see diagram) must be incorporated to protect the equipment from overheating,

Description

The braking resistors are for use with the MICROMASTER Vector range of inverters. They enable high inertia loads to be decelerated rapidly. During deceleration of the motor and load, excess energy is returned to the inverter and is stored in the dc-link capacitors. This causes an increase in the dc-link voltage, which, if too high will trip the inverter. The inverter dissipates the excess energy to the externally-mounted braking resistor.

The resistor case is manufactured from extruded aluminium to dissipate the heat generated during braking/deceleration.

Technical Data

Ambient operating temperature:	0 to 50°C
Storage/transport temperature:	-30 to +85°C
Degree of protection:	IP54
Humidity:	0 to 95% (non-condensing)

Installation

The resistors must be installed in a vertical position and secured to a metal surface (> 0.5 m² area) using two/four M5 screws. They are convection-cooled, so a free space of at least 100 mm must be left above and below the components to allow an unimpeded air flow. The resistor must be mounted at least 50 mm from the side of the inverter to prevent excessive heating of the units.

The thermal cut-out switch supplied with the braking resistor should be installed directly onto the resistor body.

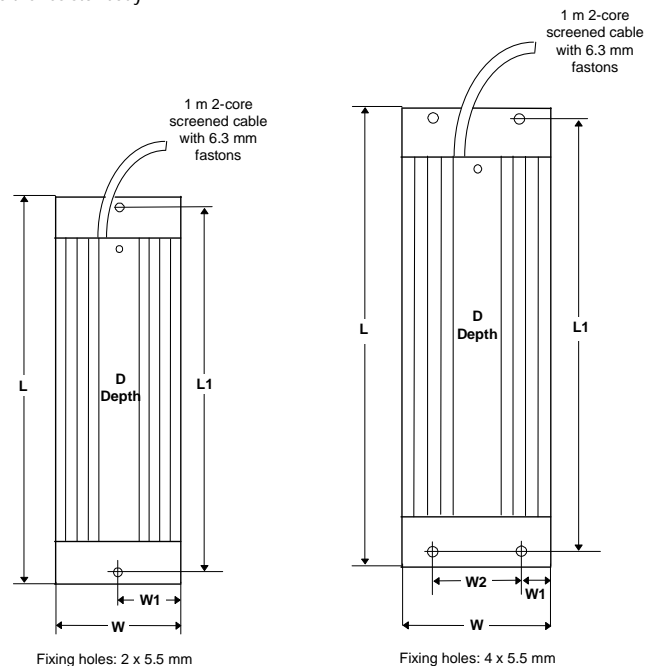

Order Nos: 6SE3290-0CA87-2RA0
6SE3290-0CB87-2RA0
6SE3290-0DA87-2RA0

Order Nos: 6SE3290-0CC87-2RA0
6SE3290-0DB87-2RA0
6SE3290-0DC87-2RA0

Connecting Up

Resistor Protection

It is important that the mains supply to the inverter is provided via a contactor which can disconnect the supply if the resistor overheats. Under certain conditions (e.g. due to operation outside normal tolerance) a resistor could overheat, so additional thermal protection must be installed.

Protection is provided by a thermal cut-out switch (supplied with each resistor). This mounts directly onto the resistor and is wired in-series with the supply from the main contactor (see diagram).

The main contactor will then de-energise to disconnect the mains power supply from the inverter. This prevents the braking resistor from drawing excessive current from the inverter.

The thermal switch contacts close again when the resistor temperature falls, thus reconnecting the mains power supply to the contactor and power to the inverter.

WARNING

Make sure that the resistor to be fitted to the MICROMASTER Vector is adequately rated to handle the required level of power dissipation.

Using an incorrect braking resistor can cause severe damage to the associated inverter and may result in a fire.

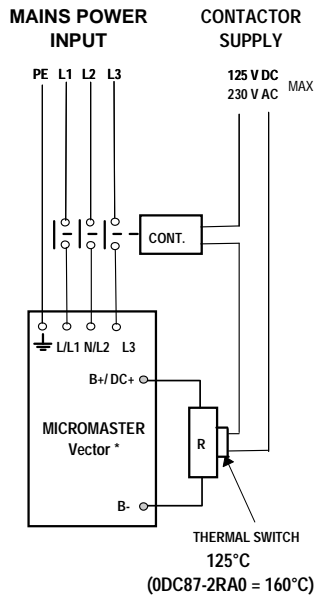

* Note: Refer to the inverter's handbook for the location of the braking resistor terminals.

Cable Requirements		Thermal Switch contacts		
B+/DC +ve B -ve	Thermal Cut-out Switch	Opening temp.	Closing temp.	Rating at 230 V
2.5 mm ² 2-core (1000 V) with screen	1.5 mm ² 2-core 125°C	125°C or 160°C (0DC87- 2RA0)	110°C or 145°C (0DC87- 2RA0)	10 A 10 A

Connecting to the MICROMASTER Vector

The braking resistor must be connected directly to the DC link of the MICROMASTER Vector via the inverter's B+/DC+ and B- terminals. Connect the braking resistor into the system, as follows:

- Remove mains power from the MICROMASTER Vector and allow at least **five minutes** for the internal capacitors to discharge.
- Route the resistor cables through the appropriate gland. Strip back the screen of the resistor connector cable to approximately 135 mm from the faston connectors.
- Connect the braking resistor to the B+/DC+ and B- terminals on the MICROMASTER Vector using the 6.3 mm faston connectors on the resistor cables and connect the cable screen to the gland or a suitable PE terminal.
- Secure the thermal cut-out switch onto the resistor using two clips.
- Connect the thermal cut-out switch as shown below using suitable cable.

Commissioning

Parameter Changes

- Connect mains electrical power to the MICROMASTER Vector.
- Set parameter P009 = 3.
- Set parameter P075 = 1.
- Set parameter P066 = 0.
- Ensure that parameter P070 = 0.

Optimising Braking Action

Adjust the ramp-down time on the MICROMASTER Vector (P003) to provide the required braking action.

The ramp-down time should be kept within the braking resistor peak power dissipation.

Extremely short ramp-down times or high inertia loads will cause the MICROMASTER Vector to trip and display fault code **F001**.

Braking Resistor Selection

WARNING

Make sure that the resistor to be fitted to the MICROMASTER Vector is adequately rated to handle the required level of power dissipation.

Using an incorrect braking resistor can cause severe damage to the associated inverter and may result in a fire.

Resistor Order No. 6SE3290-	Continuous Rating	Peak Rating (5% duty cycle)	Resistance (Ω) +/- 10%	Pk. volts DC	Dimensions (mm)						Weight kg	Inverter Type
					L	L1	W	W1	W2	D		
OCA87-2RA0	40 W	800 W	200	450	200	190	57	28	-	54	1.3	MMV12 - MMV75 MMV12/2 - MMV75/2
OCB87-2RA0	80 W	1.6 kW	100		280	271	57	28	-	54	1.7	MMV110 - MMV150 MMV110/2 - MMV150/2
OCC87-2RA0	200 W	4 kW	40		338	330	80	20	40	54	3.1	MMV220 - MMV300 MMV220/2 - MMV400/2
ODA87-2RA0	80 W	1.6 kW	400	900	280	270	57	28	-	54	1.7	MMV37/3 - MMV150/3
ODB87-2RA0	150 W	3 kW	200		280	271	83	23	40	54	2.5	MMV220/3 - MMV300/3
ODC87-2RA0	400 W	7.5 kW	85		400	390	103	28	40	52	3.8	MMV400/3 - MMV750/3

During braking, the inverter dissipates the braking energy of the motor and load to the externally mounted resistor. The lower the value of the external resistor the greater the braking power. The resistors are able to dissipate large amounts of energy for short periods but when used continuously, the rating is considerably less. To protect the resistor and the inverter from overload, the MICROMASTER Vector 'chopper circuit' (P070) limits the duty cycle (ratio of 'time on' to 'time off') to 5% (12 seconds in 4 minutes). This reduces the maximum dissipation level of the resistor.

The resistor must be adequately rated to withstand the resulting power dissipation.