

# 8V1016.00-2

## 1 General information

- Modular mechanical design using plug-in modules
- Integrated line filter
- Integrated braking resistor
- Integrated electronic restart inhibit

## 2 Order data

Model number	Short description	Figure
	<b>Servo drives</b>	
8V1016.00-2	ACOPOS servo drive, 3x 400-480 V, 1.6 A, 0.7 kW, line filter, integrated braking resistor and electronic secure restart inhibit	
	<b>Optional accessories</b>	
	<b>Plug-in modules</b>	
8AC110.60-3	ACOPOS plug-in module, CAN interface	
8AC114.60-2	ACOPOS plug-in module, POWERLINK V2 interface	
8AC120.60-1	ACOPOS plug-in module, EnDat encoder and sine incremental encoder interface	
8AC121.60-1	ACOPOS plug-in module, HIPERFACE interface	
8AC122.60-3	ACOPOS plug-in module, resolver interface 10 kHz	
8AC123.60-1	ACOPOS plug-in module, incremental encoder and SSI absolute encoder interface	
8AC125.60-1	ACOPOS plug-in module, BiSS/SSI SinCos/SSI interface	
8AC125.60-2	ACOPOS plug-in module, BiSS encoder interface 5 V, baud rate 6.25 Mbit/s	
8AC125.61-2	ACOPOS plug-in module, BiSS encoder interface 12 V, baud rate 6.25 Mbit/s	
8AC126.60-1	ACOPOS plug-in module, EnDat 2.2 encoder interface	
8AC130.60-1	ACOPOS plug-in module, 8 digital I/O configurable in pairs as 24 V input or as output 400/100 mA, 2 digital outputs 2 A, order TB712 terminal block separately	
8AC131.60-1	ACOPOS plug-in module, 2 analog inputs $\pm 10$ V, 2 digital I/Os configurable as 24 V input or output 45 mA, order terminal block TB712 separately!	
	<b>Included in delivery</b>	
	<b>Shielding component sets</b>	
8X0040.00-1	ACOPOS shielding components set for 8V1010.xxx-x and 8V1016.xxx-x	
	<b>Terminal sets</b>	
8X0001.00-1	ACOPOS accessories, plug set for 8V1010.00 and 8V1090.00 (3 phase)	

Table 1: 8V1016.00-2 - Order data

## 3 Technical data

Model number	8V1016.00-2
<b>General information</b>	
B&R ID code	0x18D5
Slots for plug-in modules	3
Certifications	
CE	Yes
Functional safety <sup>1)</sup>	Yes
UL	cULus E225616 Power conversion equipment
EAC	Yes
KC	Yes
<b>Mains connection</b>	
Permissible network configurations	TT, TN <sup>2)</sup>
Mains input voltage	3x 400 VAC to 480 VAC $\pm 10\%$ 3x 230 VAC $\pm 10\%$ <sup>3)</sup>
Frequency	50 / 60 Hz $\pm 4\%$
Installed load	Max. 2.1 kVA

Table 2: 8V1016.00-2 - Technical data

Model number	8V1016.00-2
Inrush current	2 A (at 400 VAC)
Switch-on interval	>10 s
Integrated line filter per EN 61800-3, category C3 <sup>4)</sup>	Yes
Power dissipation at device nominal power without braking resistor	110 W
<b>DC bus connection</b>	
DC bus capacitance	165 µF
<b>24 VDC power supply</b>	
Input voltage <sup>5)</sup>	24 VDC +25% / -20%
Input capacitance	5600 µF
Current consumption <sup>6)</sup>	Max. 1.47 A + current for motor holding brake
<b>Motor connection</b>	
Quantity	1
Continuous current <sup>7)</sup>	1.6 A <sub>eff</sub>
Reduction of continuous current depending on ambient temperature	
Mains input voltage: 400 VAC	
Switching frequency 5 kHz	No reduction
Switching frequency 10 kHz	No reduction <sup>8)</sup>
Switching frequency 20 kHz	No reduction
Mains input voltage: 480 VAC	
Switching frequency 5 kHz	No reduction
Switching frequency 10 kHz	No reduction <sup>8)</sup>
Switching frequency 20 kHz	0.13 A <sub>eff</sub> per °C (starting at 40°C)
Reduction of continuous current depending on installation elevation	
Starting at 500 m above sea level	0.16 A <sub>eff</sub> per 1000 m
Peak current	5 A <sub>eff</sub>
Nominal switching frequency	10 kHz
Possible switching frequencies	5 / 10 / 20 kHz
Electrical stress of connected motor per IEC TS 60034-25 <sup>9)</sup>	Limit value curve A
Max. motor cable length	15 m
Protective measures	
Overload protection	Yes
Short circuit and ground fault protection	Yes
Max. output frequency	598 Hz <sup>10)</sup>
Terminal connection cross section	
Flexible and fine-stranded wires	
With wire end sleeves	0.25 to 4 mm <sup>2</sup>
Approbation data	
UL/C-UL-US	30 to 10 AWG
CSA	28 to 10 AWG
<b>Motor holding brake connection</b>	
Response threshold for open circuit monitoring	Approx. 245 mA
Max. output current	1.3 A
Max. number of switching cycles	Unlimited since handled electronically
<b>Braking resistor</b>	
Peak power output	2 kW
Continuous power	130 W
<b>Limit switch and reference inputs</b>	
Quantity	3
Circuit	Sink
Electrical isolation	
Input - ACOPOS	Yes
Input - Input	No
Input voltage	
Nominal	24 VDC
Maximum	30 VDC
Switching threshold	
Low	<5 V
High	>15 V
Input current at nominal voltage	Approx. 4 mA
Switching delay	Max. 2.0 ms
Modulation compared to ground potential	Max. ±38 V
<b>Enable inputs</b>	
Quantity	1
Circuit	Sink
Electrical isolation	
Input - ACOPOS	Yes
Input voltage	
Nominal	24 VDC
Maximum	30 VDC

Table 2: 8V1016.00-2 - Technical data

Model number	8V1016.00-2
Input current at nominal voltage	Approx. 30 mA
Switching threshold	
Low	<5 V
High	>15 V
Switching delay	
Enable 0 → 1, ready for PWM	Max. 100 µs
Enable 1 → 0, PWM off	Max. 2.0 ms
Modulation compared to ground potential	Max. ±38 V
OSSD signal connections <sup>11)</sup>	Not permitted
<b>Trigger inputs</b>	
Quantity	2
Circuit	Sink
Electrical isolation	
Input - ACOPOS	Yes
Input - Input	No
Input voltage	
Nominal	24 VDC
Maximum	30 VDC
Switching threshold	
Low	<5 V
High	>15 V
Input current at nominal voltage	Approx. 10 mA
Switching delay	
Rising edge	52 µs ±0.5 µs (digitally filtered)
Falling edge	53 µs ±0.5 µs (digitally filtered)
Modulation compared to ground potential	Max. ±38 V
<b>Electrical properties</b>	
Discharge capacitance	550 nF
<b>Operating conditions</b>	
Permissible mounting orientations	
Hanging vertically	Yes
Horizontal, face up	Yes
Standing horizontally	No
Installation elevation above sea level	
Nominal	0 to 500 m
Maximum <sup>12)</sup>	2000 m
Pollution degree per EN 61800-5-1	2 (non-conductive pollution)
Overvoltage category per EN 61800-5-1	II
Degree of protection per EN 60529	IP20
<b>Ambient conditions</b>	
Temperature	
Operation	
Nominal	5 to 40°C
Maximum <sup>13)</sup>	55°C
Storage	-25 to 55°C
Transport	-25 to 70°C
Relative humidity	
Operation	5 to 85%
Storage	5 to 95%
Transport	Max. 95% at 40°C
<b>Mechanical properties</b>	
Dimensions	
Width	58.5 mm
Height	257 mm
Depth	220 mm
Weight	2.5 kg

Table 2: 8V1016.00-2 - Technical data

- 1) Achievable safety classifications (safety integrity level, safety category, performance level) are documented in the user's manual (section "Safety technology").
- 2) In the USA, TT and TN power mains are commonly referred to as "Delta/Wye with grounded Wye neutral".
- 3) If the module is operated with a mains input voltage of 3x 230 VAC, then automatic nominal voltage detection doesn't work for the DC bus. The UDC\_NOMINAL parameter must be set to 325 [V] by the user in this case.
- 4) Limit values from EN 61800-3 C3 (second environment).
- 5) The permissible input voltage range is reduced when using motor holding brakes. The input voltage range should be selected so that the proper supply voltage for the motor holding brake can be maintained.
- 6) The current requirements depend on the configuration of the ACOPOS servo drive  
The inrush current is significantly higher than the value for current consumption and can be estimated according to the input capacitance.
- 7) Valid in the following conditions: 400 VAC mains input voltage, nominal switching frequency, 40°C ambient temperature, installation elevation <500 m above sea level.
- 8) Value for the nominal switching frequency.
- 9) If necessary, the stress of the motor isolation system can be reduced by an additional externally wired dv/dt choke. For example, the RWK 305 three-phase dv/dt choke from Schaffner ([www.schaffner.com](http://www.schaffner.com)) can be used. Important: Even when using a dv/dt choke, it is necessary to ensure that an EMC-compatible, low inductance shield connection is used!

- 10) The module's electrical output frequency (SCTRL\_SPEED\_ACT \* MOTOR\_POLEPAIRS) is monitored to protect against dual use in accordance with EC regulation 428/2009 | 3A225. If the electrical output frequency of the module exceeds the limit value of 598 Hz uninterrupted for more than 0.5 s, then the current movement is aborted and error 6060 is output (Power element: Limit speed exceeded).
- 11) OSSD (output signal switching device) signals are used to monitor signal lines for short circuits and cross faults.
- 12) Continuous operation of ACOPOS servo drives at elevations ranging from 500 m to 2000 m above sea level is possible (taking the specified continuous current reductions into consideration).
- 13) Continuous operation of ACOPOS servo drives at ambient temperatures ranging from 40°C to max. 55°C is possible (taking the specified continuous current reductions into consideration), but this will result in a shorter service life.

## 4 Status indicators

ACOPOS servo drives are equipped with three LEDs for direct diagnostics:



Figure 1: ACOPOS servo drive indicators

### LED status indicators

Label	Color	Function	Description	
READY	Green	Ready	Solid green	The module is operational and the power stage can be enabled (operating system present and booted, no permanent or temporary errors).
			Blinking green <sup>1)</sup>	The module is not ready for operation. <u>Examples:</u> <ul style="list-style-type: none"> <li>• No signal on one or both enable inputs</li> <li>• DC bus voltage outside the tolerance range</li> <li>• Overtemperature on the motor (temperature sensor)</li> <li>• Motor feedback not connected or defective</li> <li>• Motor temperature sensor not connected or defective</li> <li>• Overtemperature on the module (IGBT junction, heat sink, etc.)</li> <li>• Disturbance on network</li> </ul>
RUN	Orange	Run	Solid orange	The module's power stage is enabled.
ERROR	Red	Error	Solid red <sup>1)</sup>	There is a permanent error on the module. <u>Examples:</u> <ul style="list-style-type: none"> <li>• Permanent overcurrent</li> <li>• Invalid data in EPROM</li> </ul>

Table 3: ACOPOS servo drive - LED status indicators

1) Firmware V2.130 and later.

If no LED is lit up, the ACOPOS servo drive is not supplied with 24 VDC mains voltage.

### Danger!

**After switching off the device, wait for the DC bus to discharge for at least five minutes. To avoid a hazard, the current voltage on the DC bus must be measured with a suitable measuring instrument and less than 42 VDC before starting work. An unlit operating LED does not indicate that the device is de-energized!**

#### 4.1 Status changes when starting up the operating system loader

The following intervals are used for the LED status indicators:

Width of box: 125 ms  
Repeats after: 3000 ms

Status	LED	Display
1. Boot procedure for base hardware active	Green	[Grid of 20 empty cells]
	Orange	[Grid of 20 empty cells]
	Red	[Grid of 20 red cells]
2. Network plug-in module configuration active	Green	[Grid of 20 green cells]
	Orange	[Grid of 20 empty cells]

Table 4: Status changes when starting up the operating system loader

Status	LED	Display
3. Waiting for network telegram	Red	[Red]
	Green	[Green]
	Orange	[Orange]
4. Network communication active	Red	[Red]
	Green	[Green]
	Orange	[Orange]

Table 4: Status changes when starting up the operating system loader

### Error status with reference to CAN plug-in module AC110

Status	LED	Display
Invalid hardware ID <sup>1)</sup>	Green	[Green]
	Orange	[Orange]
	Red	[Red]
Boot error in CAN base hardware	Green	[Green]
	Orange	[Orange]
	Red	[Red]
Bus off	Green	[Green]
	Orange	[Orange]
	Red	[Red]
The CAN station number is 0.	Green	[Green]
	Orange	[Orange]
	Red	[Red]

Table 5: Error status with reference to CAN plug-in module AC110

- 1) Possible errors:
- The ACOPOS servo drive is defective.
  - The plug-in module is defective
  - The plug-in module is not connected properly in the slot.

### Error status with reference to POWERLINK V2 plug-in module AC114

Status	LED	Display
Invalid hardware ID <sup>1)</sup>	Green	[Green]
	Orange	[Orange]
	Red	[Red]
Boot error in POWERLINK base hardware	Green	[Green]
	Orange	[Orange]
	Red	[Red]
Error booting the AC114-ARM	Green	[Green]
	Orange	[Orange]
	Red	[Red]
The POWERLINK station number is 0.	Green	[Green]
	Orange	[Orange]
	Red	[Red]

Table 6: Error status with reference to POWERLINK V2 plug-in module AC114

- 1) Possible errors:
- The ACOPOS servo drive is defective (plug-in module not detected).
  - The plug-in module is defective
  - The plug-in module is not connected properly in the slot.
  - The plug-in module works but is not automatically detected by the ACOPOS servo drive (old bootstrap loader).

## 5 Dimension diagram and installation dimensions

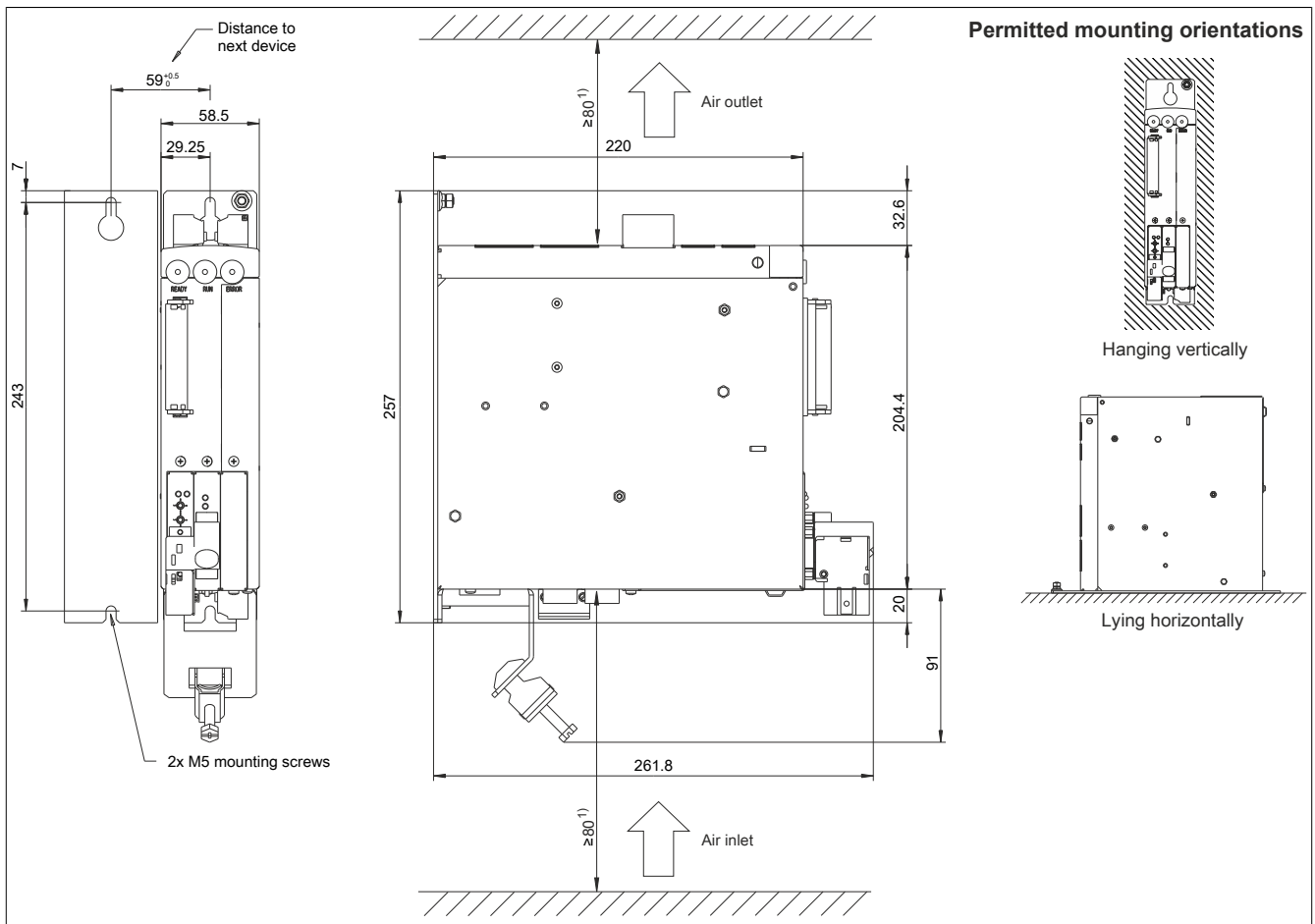

Figure 2: Dimension diagram and installation dimensions

- 1) For proper air circulation, at least 80 mm clearance must be available above and below the ACOPOS servo drive. Approximately 100 mm clearance is required under the ACOPOS servo drive to prevent cabling problems.

# 6 Wiring

## Pinout overview

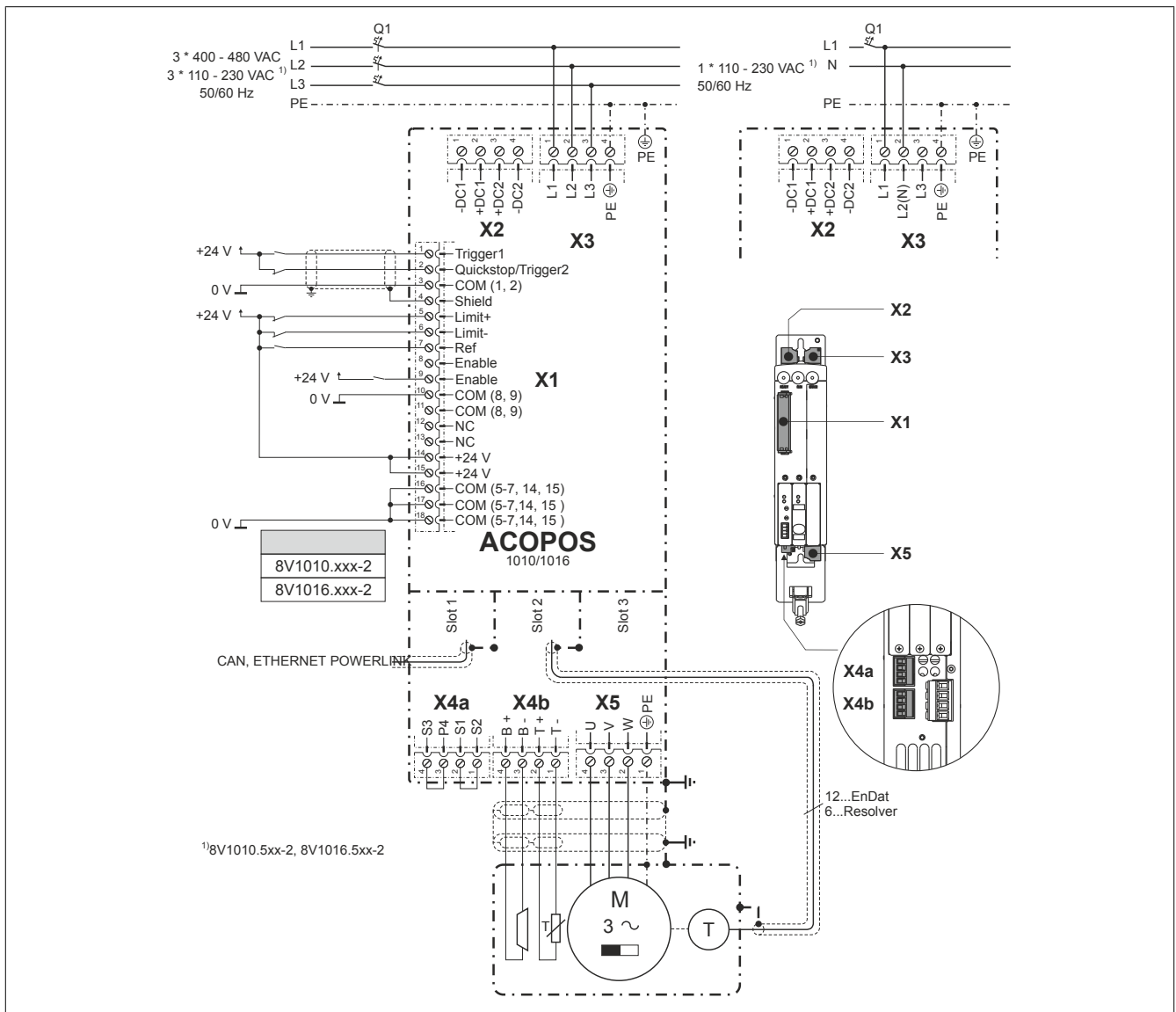



Figure 3: ACOPOS 1010, 1016 - Pinout overview

## 6.1 X1 - Pinout

X1	Pin	Name	Function
	1	Trigger1	Trigger 1
	2	Quickstop/Trigger2	Quickstop/Trigger2
	3	COM (1, 2)	Trigger 1, Quickstop/Trigger 2 0 V
	4	Shield	Shield
	5	Limit+	Positive HW limit
	6	Limit-	Negative HW limit
	7	Ref	Reference switch
	8	Enable <sup>1)</sup>	Enable
	9	Enable <sup>1)</sup>	Enable
	10	COM (8, 9)	Enable 0 V
	11	COM (8, 9)	Enable 0 V
	12	---	---
	13	---	---
	14	+24 V	+24 V supply
	15	+24 V	+24 V supply
	16	COM (5-7, 14, 15)	0 V supply
	17	COM (5-7, 14, 15)	0 V supply
	18	COM (5-7, 14, 15)	0 V supply

The following connections are linked with each other internally in the device:

- Pin 8 --> Pin 9 (Enable)
- Pin 10 --> Pin 11 (Enable 0 V)
- Pin 14 --> Pin 15 (Supply +24 V)
- Pin 16 --> Pin 17 --> Pin 18 (Supply 0 V)

Table 7: X1 - Pinout

1) The wiring is not permitted to exceed a total length of 30 m.

### Information:

To obtain a defined reference of ground to ground potential, B&R recommends grounding the COM connections (5-7, 14, 15) on connector X1.

## 6.2 X2 - Pinout

X2	Pin	Name	Function
	1	-DC1	U DC bus -
	2	+DC1	U DC bus +
	3	+DC2	U DC bus +
	4	-DC2	U DC bus -

Table 8: X2 - Pinout

## 6.3 X3 - Pinout

X3	Pin	Name	Function
	1	L1	Power mains connection L1
	2	L2	Power mains connection L2
	3	L3	Power mains connection L3
	4	PE	Protective ground conductor

Table 9: X3 - Pinout

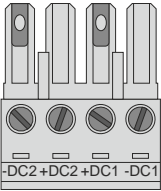

## 6.4 X4a, X4b - Pinout

X4a	Pin	Description	Function
	1	S2 <sup>1)</sup>	Enabling, power supply of external holding brake (+)
	2	S1 <sup>1)</sup>	Enabling of external holding brake (+)
	3	S4	Enabling, power supply of external holding brake (-)
	4	S3	Enabling of external holding brake (-)

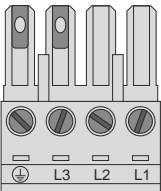
Table 10: X4a - Pinout

- 1) If the holding brake is connected via an additional external relay contact (ground-in e.g. via connections S1/S2) instead of only via the internal transistor, then the internal quenching circuit has no effect! In this case, the customer must make sure that neither the relay contact nor the braking coil are damaged when switching off the brake. This can be done by interconnecting the coil or - better still - interconnecting the contact with a quenching circuit.

X4b	Pin	Description	Function
	1	T-	Temperature sensor -
	2	T+	Temperature sensor +
	3	B- <sup>1)</sup>	Brake -
	4	B+ <sup>1)</sup>	Brake +

Table 11: X4b - Pinout

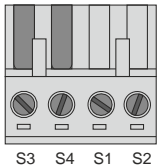
- 1) If the holding brake is connected via an additional external relay contact (ground-in e.g. via connections S1/S2) instead of only via the internal transistor, then the internal quenching circuit has no effect! In this case, the customer must make sure that neither the relay contact nor the braking coil are damaged when switching off the brake. This can be done by interconnecting the coil or - better still - interconnecting the contact with a quenching circuit.

### Danger!

The connections for the motor temperature sensors and the motor holding brake are safely isolated circuits. These connections are therefore only permitted to be connected to devices or components that have sufficient isolation per IEC 60364-4-41 or EN 61800-5-1.

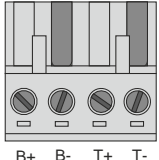
### Caution!

If B+ and B- are swapped when connecting the permanent magnet holding brakes, then the brakes cannot be opened! ACOPOS servo drives cannot determine if a holding brake is connected with reverse polarity!

### 6.4.1 Wiring the connections for the motor holding brake

The power supply, enabling and monitoring of the output for the motor holding brake can be carried out in three different ways via the wiring of connector X4a:

	Figure	Description
1		<ul style="list-style-type: none"> <li>• <b>Power supply:</b> Internal via the ACOPOS servo drive</li> <li>• <b>Enabling:</b> Internal via the ACOPOS servo drive</li> <li>• <b>Monitoring:</b> Internal via the ACOPOS servo drive</li> </ul> <p>Jumpers must be placed between connections S1 and S2 as well as S3 and S4 on connector X4a. <sup>1)</sup></p>
2		<ul style="list-style-type: none"> <li>• <b>Power supply:</b> Internal via the ACOPOS servo drive</li> <li>• <b>Enabling:</b> Possible internally by the ACOPOS servo drive and externally by dry contacts <sup>2)</sup></li> <li>• <b>Monitoring:</b> Internal via the ACOPOS servo drive</li> </ul> <p><b>Information:</b> ACOPOS-internal monitoring must be configured according to the requirements of the application. <sup>3)</sup></p>
3		<ul style="list-style-type: none"> <li>• <b>Power supply:</b> External</li> <li>• <b>Enabling:</b> External</li> <li>• <b>Monitoring:</b> External</li> </ul> <p><b>Information:</b> ACOPOS-internal monitoring cannot be used here; it must therefore be disabled using software. <sup>4)</sup></p>

Table 12: Enabling the external holding brake

- 1) The two jumpers are already wired on connector X4a supplied with ACOPOS servo drives.
- 2) External dry contacts can be connected between S1 and S2 and between S3 and S4. This makes it possible to enable the holding brake via external safety circuits independently of the control integrated in the ACOPOS servo drive.
- 3) Configuration takes place using ParID 90 (1 ... Internal monitoring active, 5 ... Internal monitoring not active).
- 4) Disabling takes place using ParID 90 (5 ... Internal monitoring not active).

## 6.5 X5 - Pinout

X5	Pin	Name	Function
	1	PE	Protective ground conductor
	2	W	Motor connection W
	3	V	Motor connection V
	4	U	Motor connection U

Table 13: X5 - Pinout

## 6.6 Additional protective ground connection (PE)

The protective ground conductor is connected to the M5 threaded bolt provided using a cable lug.

Figure	Pin	Name	Function
	---	PE	Protective ground conductor
<b>Terminal cross sections</b> Cable lug for M5 threaded bolt		<b>[mm<sup>2</sup>]</b> 0.25 - 16	<b>AWG</b> 23 - 5

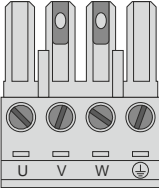
Table 14: Protective ground connection (PE) - ACOPOS

### Danger!

**Before turning on the servo drive, make sure that the housing is properly connected to ground (PE rail). The ground connection must be established even when testing the drive or operating it for a short time!**

### 6.7 Input/output circuit diagram

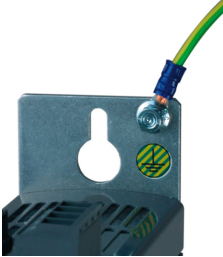
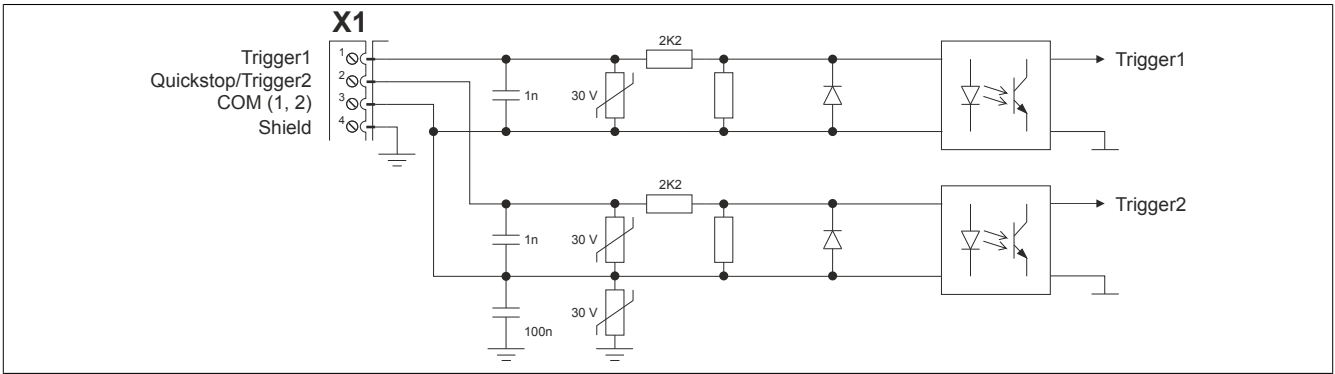

Figure 4: Trigger

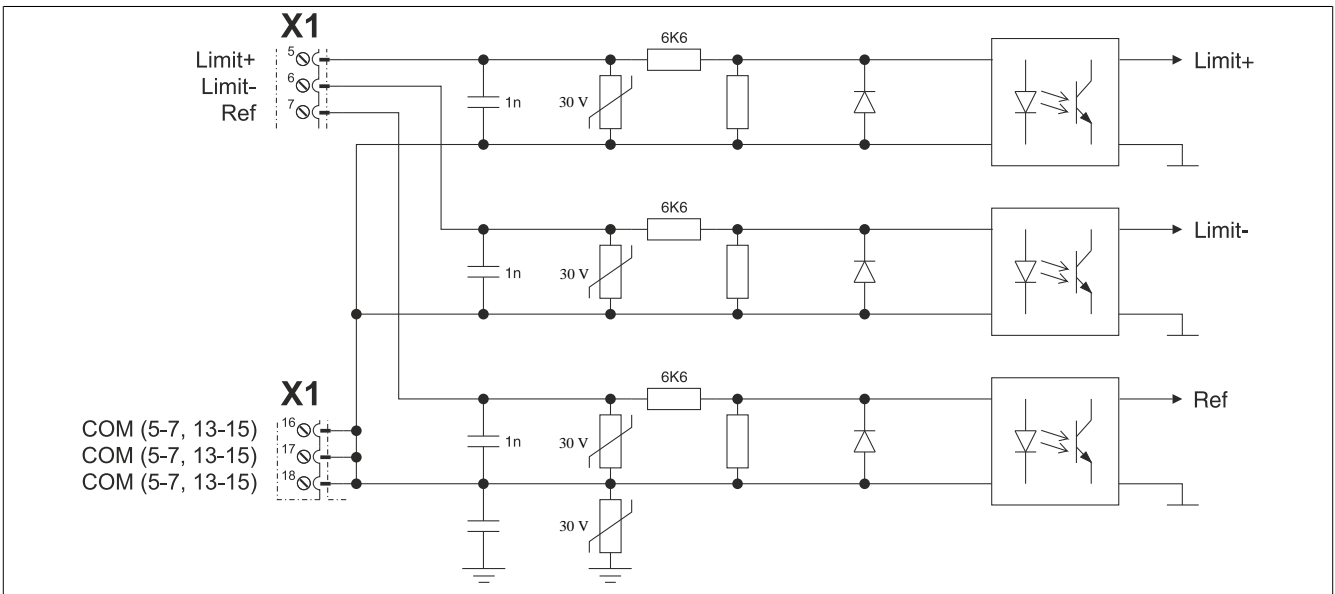

Figure 5: Limit

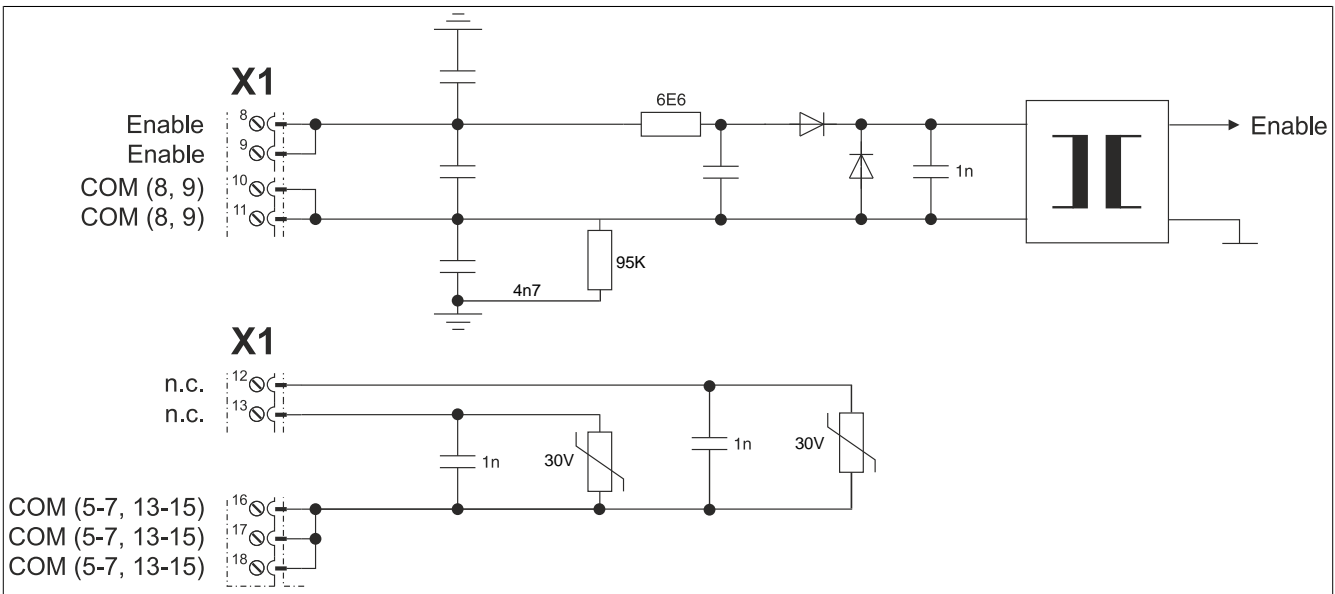

Figure 6: Enable

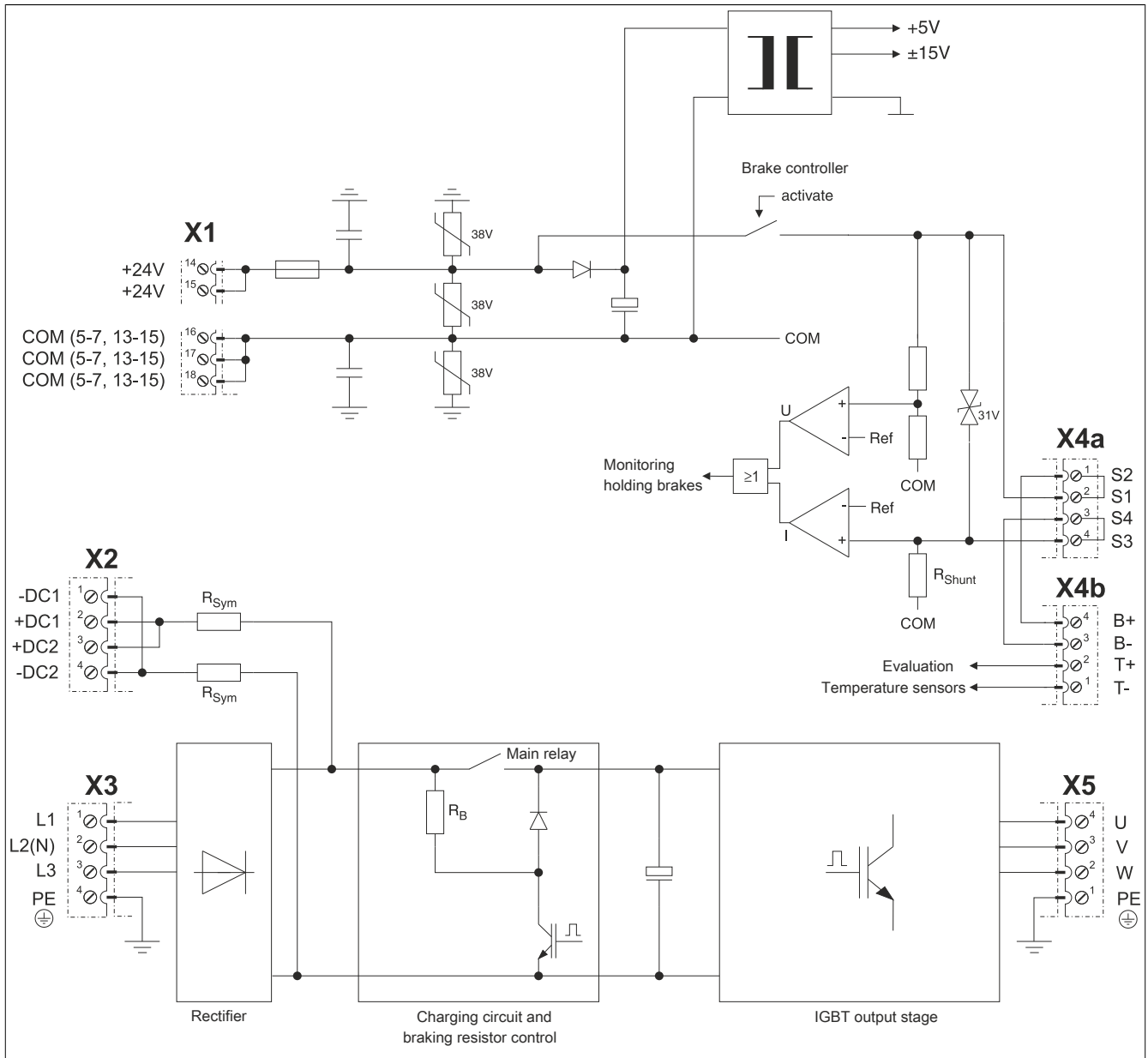

Figure 7: Input/output circuit diagram - ACOPOS 1010, 1016