

SIEMENS

SIMATIC

Distributed I/O Device ET 200R

Manual

Foreword, Table of Contents

Product Overview 1

Possible Configurations 2

Installation 3

Wiring 4

Commissioning and
Diagnosis 5

General Technical
Data 6

Technical Data 7

Appendix A

Technical safety notes

This documentation contains information which you must adhere to for your own personal safety and for the avoidance of property damage. The information is highlighted with a warning triangle. The degree of danger is presented as shown below.



Danger

Means that death, severe injury or substantial property damage will occur if the appropriate precautions are not taken.



Warning

Means that death, severe injury or substantial property damage may occur if the appropriate precautions are not taken.



Caution

With a warning triangle: means that minor injury may occur if the appropriate precautions are not taken.

Caution

With no warning triangle: means that property damage may occur if the appropriate precautions are not taken.

Attention

Means that an undesired result or an undesired state may occur if this information is not adhered to.

Note

Important information on the product, the handling of the product, or the particular part of the documentation which requires special attention.

Intended use



Warning

The described product may only be used for the applications stated in this documentation and only in connection with Siemens components or components and devices of other manufacturers which been recommended or authorized by Siemens.

Brands

SIMATIC® is a registered brand of Siemens AG.

The other designations used in this publication may be brands whose use by third parties for their own purposes may violate the rights of the owners.

Copyright © Siemens AG 2004 All rights reserved

Passing on and duplication of this document as well as utilization and revelation of its contents is not permitted without express permission. Violators will be prosecuted for damages. All rights reserved particularly in the event a patent is granted or a utility model is registered. The designations used in this documentation may be brands whose use by third parties for their own purposes may violate the rights of the owners.

Disclaimer of liability

Although we have checked the contents of this publication for correspondence to the described hardware and software, errors cannot be excluded. The information in this publication is checked at regular intervals and necessary corrections included in the next edition. Your comments and ideas are welcome. Subject to technical change without prior notice

Foreword

Purpose of this manual

The information in this manual will enable you to operate the ET 200R distributed I/O device on PROFIBUS-DP as a standard slave.

It is written for the people involved in the configuring, commissioning and servicing of programmable controllers.

Required basic knowledge

Comprehension of this manual requires a general knowledge of automation technology.

In addition, a knowledge of the use of computers or PC-like resources (e.g., programmers) under the operating systems Windows 95/98/ME/NT or NT/2000 is required. Acknowledge of configuration methods (e.g., with COM PROFIBUS) is also assumed.

Circle of readers

This manual is written for people who possess the necessary qualifications for commissioning and running the ET 200R.

What this manual covers

This manual is valid for the ET 200R modules with the following order numbers:

ET 200R-H 6ES7 143 2BH00 0AB0 (handling module)
ET 200R-W 6ES7 143 2BH50 0AB0 (welding module)

Software prerequisites for hardware configuration

You will need the related GSD file (see current information on page 5) for configuration of the ET 200R.

Scope of delivery

- ET 200R with seven M12 covering caps
- Short description
- Terminal strip for terminal field on the back (for the welding module)

Licenses

The ET 200R distributed I/O device conforms to the following regulations:

- EG guideline 89/336/EWG on electromagnetic compatibility
- Certification as standard DP slave
- **cULus**
Underwriters Laboratories, Inc.: registered under UL 508 (Industrial Control Equipment)

Standards and certifications

The ET 200R distributed I/O device is based on the standard EN 50170, volume 2 (IEC 61158), PROFIBUS. In addition, the ET 200R distributed I/O device meets the requirements and criteria of IEC 1131, part 2 and the requirements of the CE seal.

Detailed information on certifications and standards is located in the technical data (see chapter 7).

Other support

If you have technical questions, please contact your Siemens representative. You will find the address in the manuals of the DP masters (e.g., in the appendix ("Siemens Worldwide") of the manual on the S7-300 programmable controller, setup, CPU data and catalogs).

If you have questions or remarks on the manual itself, please fill in the reply card located at the end of the manual and return it to the specified address. It would also be greatly appreciated if you would take the time to enter your personal opinion of the manual on the reply form.

Current information

You will receive continuously updated current information on SIMATIC products.

In addition, SIMATIC Customer Support provides you with current information and downloads which may be useful when using SIMATIC products.

- From the Internet at <http://www.ad.siemens.de/simatic-cs> or <http://www.ad.siemens.de/csi/gsd>
- From the SIMATIC Customer Support mailbox under the number +49 (911) 895-7100

If you need the GSD file, this is available for downloading at <http://www.ad.siemens.de/csi/gsd>.

SIMATIC Customer Support can be reached by telephone at +49 0180/5050222 and by fax at +49 0180/5050223.

Send e-mail inquiries to adsupport@siemens.com

Table of Contents

1	Product Overview	1-1
1.1	What are distributed I/O Devices?	1-1
1.2	What is the ET 200R distributed I/O Device?	1-3
2	Possible Configurations	2-1
2.1	Feeding in and connecting through the voltage for Electronics/Encoders and PROFIBUS-DP	2-1
2.2	Restriction of the modules which can be connected	2-2
3	Installation.....	3-1
3.1	Mounting/Demounting the ET 200R.....	3-2
3.2	Setting/Changing the PROFIBUS address	3-3
3.3	Providing PROFIBUS with terminating resistance	3-4
4	Wiring	4-1
4.1	General rules and regulations for operating the ET 200R	4-2
4.2	Wiring the ET 200R	4-3
4.2.1	Connecting the terminal field on the back.....	4-4
4.2.2	Connecting the bus plugs	4-5
4.2.3	Plug Connectors for the Digital Inputs and Outputs.....	4-6
5	Commissioning and Diagnosis	5-1
5.1	Configuring the ET 200R	5-1
5.2	Commissioning and startup of the ET 200R.....	5-2
5.3	Diagnosis with LED indicators	5-4
5.4	Diagnostic Messages.....	5-6
5.4.1	Reading the diagnosis	5-6

5.5	Layout of the ET 200R slave diagnosis	5-7
5.5.1	Station status 1 to 3	5-8
5.5.2	Master PROFIBUS Address	5-9
5.5.3	Manufacturer's ID.....	5-10
5.5.4	ID-Related Diagnosis	5-10
5.5.5	Module status.....	5-11
5.5.6	Device-specific diagnosis.....	5-11
6	General Technical Data	6-1
6.1	Standards and certifications.....	6-1
6.2	Electromagnetic compatibility	6-2
6.3	Physical and climatic ambient conditions.....	6-3
6.4	Information on isolation tests, protection class, protection rating and nominal voltage of the ET 200R.....	6-4
7	Technical Data	7-1
A	Appendix	A-1

Figures

Figure 1–1	Typical configuration of a PROFIBUS-DP network	1-2
Figure 1–2	Allocation of the plug connectors and LEDs on the ET 200R	1-4
Figure 2–1	Feeding in and connecting through power and PROFIBUS-DP in a hybrid line...	2-2
Figure 3–1	Dimensions for the mounting holes	3-2
Figure 3–2	Accessing the rotary switches for setting the PROFIBUS address	3-3
Figure 3–3	Rotary switches (tens on left-hand switch, ones on right-hand switch)	3-4
Figure 4–1	Floor cutout on welding module ET 200R-W	4-4
Figure 4–2	Ejector for the terminal strip	4-5
Figure 4–3	Allocation of plugs X01 / X02	4-6
Figure 4–4	Y connection piece	4-7
Figure 5–1	Startup of the ET 200R.....	5-3
Figure 5–2	Layout of the ET 200R slave diagnosis	5-7
Figure 5–3	Layout of the ID-related diagnosis for ET 200R	5-10
Figure 5–4	Layout of the module status for the ET 200R.....	5-11
Figure 5–5	Layout of the device-specific diagnosis	5-12

Tables

Table 4–1	Allocation of the terminal field on the back.....	4-5
Table 4–2	Pin allocation of the coupling plug of the digital inputs/outputs (X0 to X7).....	4-7
Table 4–3	Pin allocation of the coupling plugs for digital inputs/outputs when the Y connection piece is used.....	4-8
Table 5–1	Pin allocation of the sockets for 8-channel digital inputs.....	5-1
Table 5–2	Software pre-requisites for commissioning the ET 200R.....	5-2
Table 5–3	Hardware pre-requisites for commissioning the ET 200R	5-2
Table 5–4	Allocation of the LEDs	5-4
Table 5–5	Status and error indicators on the ET 200R.....	5-4
Table 5–6	Reading the diagnosis from the ET 200R	5-6
Table 5–7	Layout of station status 1 (byte 0), ET 200R	5-8
Table 5–8	Layout of station status 2 (byte 1), ET 200R	5-9
Table 5–9	Layout of station status 3	5-9
Table 6–1	Ambient conditions	6-1
Table 7–1	Technical data.....	7-2

Product Overview

1

1.1 What are distributed I/O Devices?

Distributed I/O devices - application area

When a plant is being set up, the inputs and outputs to and from the process are frequently installed centrally in the programmable controller.

When the inputs/outputs are located a long way from the programmable controller, this can make wiring very time-consuming and confusing. Electromagnetic disturbances can also affect reliability.

Use of distributed I/O devices is very helpful in such situations:

- The controller CPU is installed at a central location.
- The I/O devices (inputs and outputs) are distributed on site.
- The powerful PROFIBUS-DP with its high-speed data transmission ensures that communication between the controller CPU and I/O devices is smooth.

What is PROFIBUS-DP?

PROFIBUS-DP is an open bus system based on the standard EN 50170, volume 2 (IEC 61158), PROFIBUS with the "DP" transmission protocol (DP stands for Distributed Periphery).

Physically PROFIBUS-DP is either an electrical network using shielded two-wire lines or an optical network using fiber-optic conductors.

The "DP" transmission protocol permits fast, cyclic and, if necessary, non-cyclic data communication between the controller CPU and the distributed I/O devices.

What are DP master and DP slaves?

The DP master is the link between the controller CPU and the distributed I/O devices. The DP master exchanges data with the distributed I/O devices via PROFIBUS-DP and monitors PROFIBUS-DP.

The distributed I/O devices (i.e., DP slaves) condition the data from the encoders and actuators on site so that this information can be transferred to the controller CPU via PROFIBUS-DP.

Which devices can be connected to PROFIBUS-DP?

A wide variety of devices can be connected as DP master to PROFIBUS-DP or as DP slaves provided they correspond to standard EN 50170, volume 2 (IEC 61158), PROFIBUS.

Among others, devices of the following product families can be used:

- SIMATIC S5
- SIMATIC S7/M7/C7
- SIMATIC PG/PC
- SIMATIC HMI (user interfaces OP, OS, TD)
- Distributed I/O devices
- Devices from other manufacturers

Configuration of a PROFIBUS-DP network

The following figure shows a typical configuration of a PROFIBUS-DP network. The DP masters are integrated in the particular device. For example, if the S7-400 has a PROFIBUS-DP interface, the IM 308-C master interface is installed in an S5-115U. The DP slaves are the distributed I/O devices which are connected to the DP masters with PROFIBUS-DP.

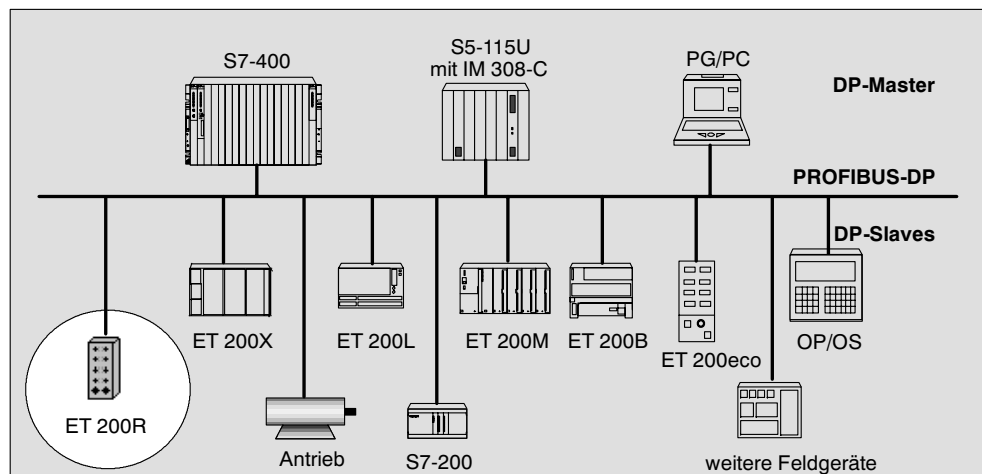

Figure 1-1 Typical configuration of a PROFIBUS-DP network

1.2 What is the ET 200R distributed I/O Device?

Definition

The ET 200R distributed I/O device is a DP slave with a protection rating of IP65. The design permits, among others, direct mounting on the Kempf box for the processing of welding signals.

Application area

- Its robust construction and IP65 protection rating make the ET 200R distributed I/O device exceptionally suited to use in rugged industrial environments.

It was especially developed for use in the raw product manufacturing of the automotive industry.

The ET 200R is used in the following applications:

- On the fixed part of the robot (on the arm) to non-reactively couple or decouple PROFIBUS and to control or monitor the tool coupling with relatively few digital inputs and outputs
- On the tool to control and monitor the handling or the welding procedure there with relatively few digital inputs and outputs and to directly loop through the analog signals of a welding tong to the welding controller. These two models will now be called handling module and welding module.
- Two versions are available:
 - Repeater or handling module (ET 200R-H)
 - Welding module (ET 200R-W) – same as the handling module but with floor hole and place to plug in analog signals SKÜ and KSR as well as temperature input.

Features of the ET 200R

- Compact design.
- Suitable for rugged industrial environments.
- Non-reactive coupling and decoupling of two PROFIBUS segments via integrated repeater function.
- 8 parametrizable digital inputs/outputs **and** 8 fixed digital inputs.
- Compatible with the Kempf box (splitting box for welding applications).
- The power supply for the electronics and encoder, PROFIBUS-DP and signal lines are fed in a common cable to the first ET 200R and then on to the next ET 200R in another common cable.
- The PROFIBUS address of the ET 200R can be set from 1 to 99 with two rotary switches.

- The front of the module has 6 LEDs for indication of functions and errors of the hardware of the ET 200R.
- Another 16 LEDs indicate the states of the digital inputs and outputs.
- Baud rates from 9.6 kBaud to 12 MBaud can be used for the ET 200R.
- PROFIBUS; galvanical isolated.

DP master for ET 200R

The ET 200R can communicate with all DP masters which behave in accordance with standard EN 50170, volume 2 (IEC 61158), PROFIBUS. Some DP masters can only process limited telegram lengths.

Check to determine whether your DP master is able to receive the telegrams from the ET 200R in their full length. A list is provided of the maximum telegram lengths for the configuration and parameterization telegrams for the ET 200R. See chapter 5.

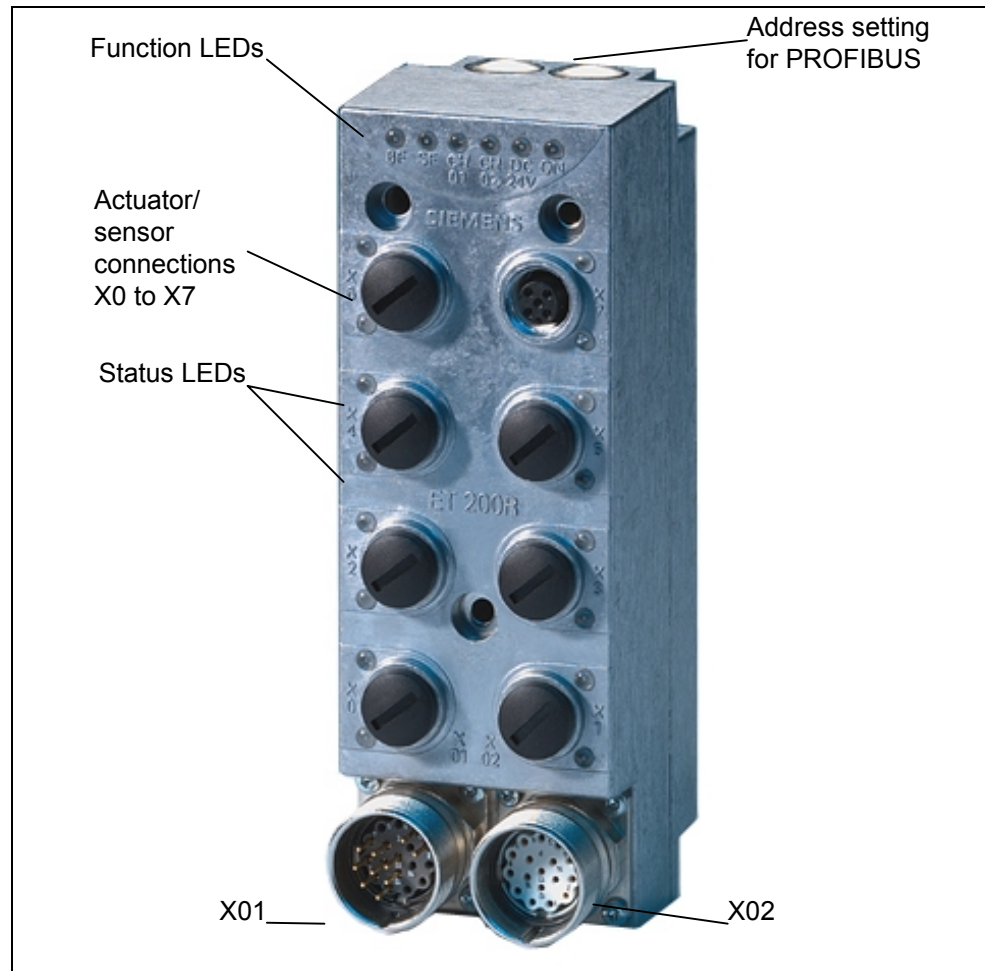

Figure 1-2 Allocation of the plug connectors and LEDs on the ET 200R

Possible Configurations

2

This chapter gives you an overview of possible configurations. The restrictions pertaining to the number of modules within a configuration are described in a separate section.

Setup guidelines for PROFIBUS networks

The setup guidelines and information in the manual for SIMATIC NET PROFIBUS NETWORKS (order no. 6GK1970-5CA20-0AA0) always apply to the setup of a PROFIBUS network with ET 200R.

In addition the following notes must be adhered to.

Terminating resistance

Terminating resistance must be provided on the first and the last station of a PROFIBUS-DP network with copper conductors (see chapter 3.3).

Due to the implemented repeater function this terminating resistance is permanently integrated on the ET 200R for every bus segment. This means that when the ET 200R is used as the last module of the PROFIBUS segment, **no** external terminating resistance is required.

2.1 Feeding in and connecting through the voltage for Electronics/Encoders and PROFIBUS-DP

Connection

With the ET 200R all power and signal lines are installed in **one** cable and connected to plug connector X01.

The second plug connector (X02) is used for looping through connections.

The pins of X01 and X02 can carry a maximum current of 9 A.

Feeding in and looping through with one cable:

The power for the electronics, encoder and load are fed together with the PROFIBUS-DP and other signal lines in one cable to the first ET 200R and then connected through to the ET 200Rs behind.

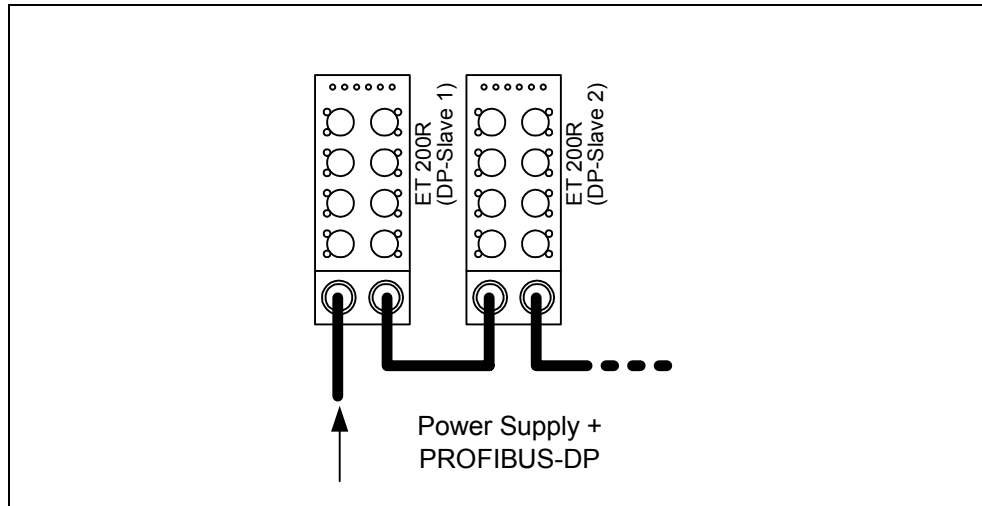

Figure 2-1 Feeding in and connecting through power and PROFIBUS-DP in a hybrid line

2.2 Restriction of the modules which can be connected

Current consumption

The maximum configuration depends on the current consumption of the individual modules. For more information see the technical data (chapter 7).

Setting the address

The number of modules is limited by the number of addresses which can be set (1 to 99).

Number of repeaters

Due to the permanently integrated repeater the number of ET 200R devices which can be installed in one PROFIBUS branch is limited to nine.

Installation

3

Caution

To avoid damaging module electronics, all voltages for the ET 200R must be turned off (i.e., de-energized) before the modules can be installed or removed.

Mounting dimensions

Dimensions of the ET 200R: 54 mm x 150 mm x 55 mm (W x L x H). Including the X01/X02 screw connections, height is 64 mm.

Settings to be made

The PROFIBUS address is set with 2 rotary switches on the ET 200R module.

When the ET 200R distributed I/O device is the first or the last DP slave in a PROFIBUS-DP network with copper conductors (RS 485 bus configuration), the bus does not need to be equipped with a terminal resistor since this is integrated in the module.

How to install

Depending on which model of the device you have the module is mounted on the robot arm or on the tool.

You will need the following to mount the module on the Kempf box:

- 1 pan head screw (DIN 6912-M4x60)
- 2 pan head screws (DIN 6912-M4x54)

If you mount the module in a different place, use screws of the same type. You must then select the length to meet the requirements.

Mounting position

The ET 200R can be mounted in any position.

3.1 Mounting/Demounting the ET 200R

Mounting the ET 200R

- If necessary, clean coarse soil from the base.
- Mount the module on the 3 mounting positions on the base with Phillips screws. Tightening moment: 2 Nm (max. of 3 Nm).
Before mounting a welding module on the Kempf box, for example, connect the transformer signals with the plug connector in the floor opening. Make sure that the terminal allocation is correct (see chapter 4.2.1).

Caution

Make absolutely sure that the floor seals of the module are in perfect condition. Otherwise protection rating IP65 is no longer provided.

Demounting the ET 200R

The module is demounted in reverse order.

Dimensional drawing showing the mounting holes

The following figure shows the dimensions for the position of the holes for the mounting screws for an ET 200R module.

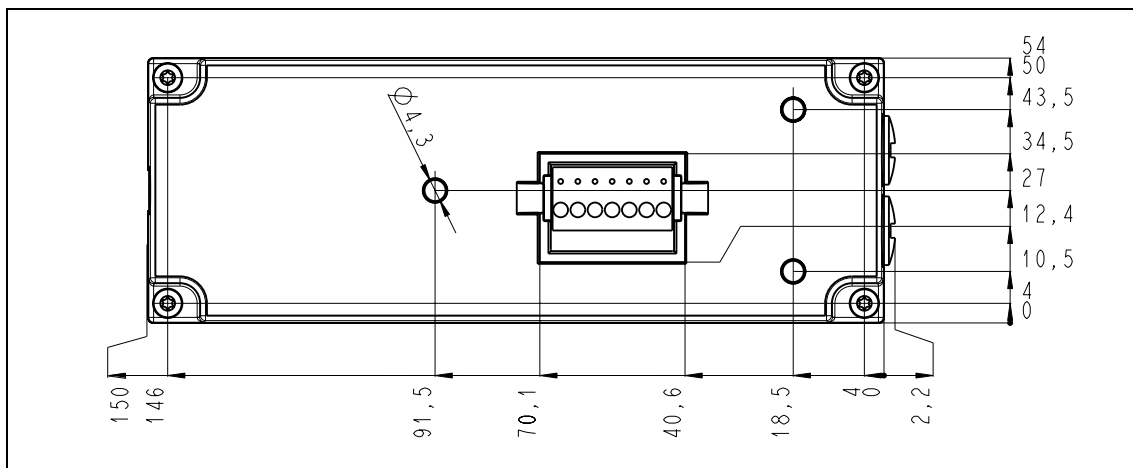

Figure 3-1 Dimensions for the mounting holes

3.2 Setting/Changing the PROFIBUS Address

The PROFIBUS address specifies the address under which the ET 200R distributed I/O device will be addressed by the DP master on PROFIBUS-DP.

The PROFIBUS address is set with the two decimal-coded, rotary switches in the module.

Permissible PROFIBUS address

A PROFIBUS address can range from 1 to 125.

Note

On delivery the PROFIBUS address is set to 0. This address must be changed since it is reserved on the ET 200 distributed I/O system for the PG/PC.

Note

Due to the rotary switch only the addresses 1 to 99 can be set on the ET 200R module. Valid address area: 3 to 99.

Setting the PROFIBUS address

The rotary switches for setting the PROFIBUS address are located inside the module behind the metric PG covering caps on the front.

- Unscrew the covering cap and pull it off.
- Set the PROFIBUS address with the rotary switches (see figure 3–3). Set the tens with the left-hand rotary switch and the ones with the right-hand rotary switch (for direction of viewing see figure 3–2).
- Screw on the covering cap again. Make sure that the seals are positioned correctly!

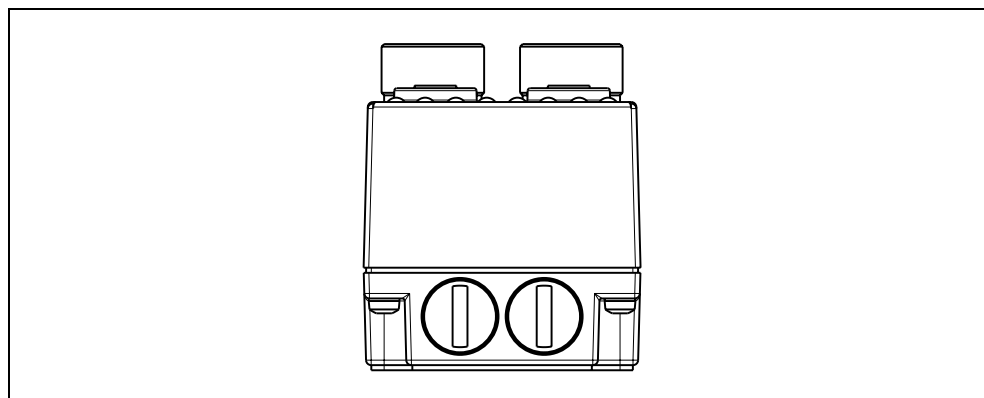

Figure 3-2 Accessing the rotary switches for setting the PROFIBUS address

Attention

The metric PG covering caps and the seals must be in perfect condition. Otherwise protection rating IP65 is no longer ensured!

Attention

Do not use the metric covering caps to cover the actuator/sensor connections.

Using the rotary switches

The rotary switches are adjusted with a screwdriver. The point of the arrow indicates the setting.

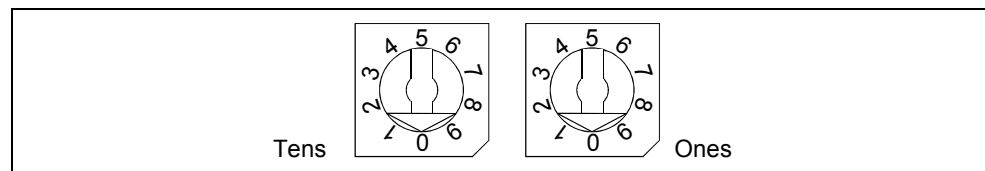

Figure 3-3 Rotary switches (tens on left-hand switch, ones on right-hand switch)

Changing the PROFIBUS address

The PROFIBUS address is changed using the same procedure you used to set the address the first time. A changed PROFIBUS address does not take effect until POWER-OFF/ON on the ET 200R.

3.3 Providing PROFIBUS with terminating resistance

Purpose of the terminating resistance

Both ends of a bus cable (i.e., on the first station and the last station of the network) must be terminated with its impedance.

Due to the implemented repeater function this terminating resistance is permanently integrated on the ET 200R for each bus segment. This means that, when the ET 200R is used as the first or last module in a segment, no external terminating resistance is required.

Wiring

4

Note

If equipotential bonding is necessary, never under any circumstances use the shield!

If necessary, secure this with an M4x8 screw in existing threading to the bottom of the ET 200R.

Note

Low safety voltage (SELV/PELV in accordance with EN 60950) must be used for all power and signal voltages.

Caution

To avoid damaging module electronics, all voltages for the ET 200R must be turned off (i.e., de-energized) before the modules are installed or removed.

Special features of wiring

- With the exception of actuator/sensor signals, all voltage and signal lines are installed in one cable.
- Actuator/sensor channels can be divided by Y plug connectors.
- When the digital input on the back is used, this channel must remain uncircuited on the front (pin X7.2 not used).

Grounding

For EMC reasons, the shield of the hybrid line must be applied on **both** ends over a large surface. (Metal plug connector housing and shield bar in the switching cabinet or flange socket in the switching cabinet.)

Ensure a low-ohmic connection of the shield on the cabinet side.

4.1 General rules and regulations for operating the ET 200R

As a component of plants or systems the ET 200R distributed I/O device requires that special rules and regulations be adhered to based on the particular application area.

This section gives you an overview of the most important rules which you will need to adhere to when you integrate your ET 200R distributed I/O device in a plant or system.

Specific application

Adhere to the safety and accident-prevention regulations for your specific application (e.g., machine guidelines 89/392/EWG).

EMERGENCY-OFF routines

EMERGENCY-OFF routines in accordance with IEC 204 (corresponds to DIN VDE 113) must remain active in all operating modes/states of the plant or system.

24 V DC voltage

The following table shows what you must keep in mind for the 24 V DC power. .

With ...	keep in mind ...	
Buildings	Exterior lightning protection	Provide lightning protection measures (e.g., lightning protection components).
24 V DC power lines, signal lines	Interior lightning protection	
24 V DC power	Secure (electrical) isolation of the low safety voltage (SELV/PELV in accordance with EN 60950) .	

Protection against exterior electrical influences

The following table shows what you must keep in mind pertaining to protection from electrical influences or faults.

With ...	keep in mind ...
All plants or systems in which the ET 200R is installed	The plant or the system is connected to function ground to divert electromagnetic interference.
Power, signal and bus lines	The lines are installed correctly.
Signal and bus lines	A line or core break may not be allowed to create an undefined state of the plant or the system.

Secure electrical isolation

Secure electrical isolation is required for all connected current circuits.

Note

All voltages and signals of the ET 200R are not galvanical isolated. Any previous galvanic isolation (e.g., of the voltages) is cancelled.

Note

With the ET 200R the reference potential of the voltages is connected directly to the reference potential of the sensors.
A short-circuit in this connection may damage the module.

Protection against the destruction of components

To prevent components of the ET 200R from being destroyed, the feeder lines for the electronics/encoder voltage and for the load voltage must be protected externally with a fuse for a max. of 9 A.

4.2 Wiring the ET 200R

Note

Before beginning installation work, turn off the main switch of the system.

How to wire the ET 200R

The ET 200R distributed I/O device is wired in three steps.

1. Connect the terminal field (X03) on the back - only when the welding module is to be installed.	See chapter 4.2.1.
2. Connect the bus plug connectors (X01, X02).	See chapter 4.2.2.
3. Connect the actuator/sensor plug connectors.	See chapter 4.2.3.

Types of cable

3-, 4- or 5-core, flexible copper cable	Connection of the actuators and sensors to the digital inputs/ outputs
Hybrid cable	Connection of the bus plug connectors

4.2.1 Connecting the terminal field on the back

Mounting

If the ET 200R module is being used for welding applications you will have to connect the transformer signals on pin strip X03 on the back before securing the module. X03 can be accessed through the opening in the floor.

1. Connect the transformer signals to the terminal strip.
Make sure that the connection allocation is correct (see figure 4–1 and table 4–1) and use core end sleeves.
2. Slide the terminal strip onto the pin strip in the floor cutout of the ET 200R module until it hits the stop.

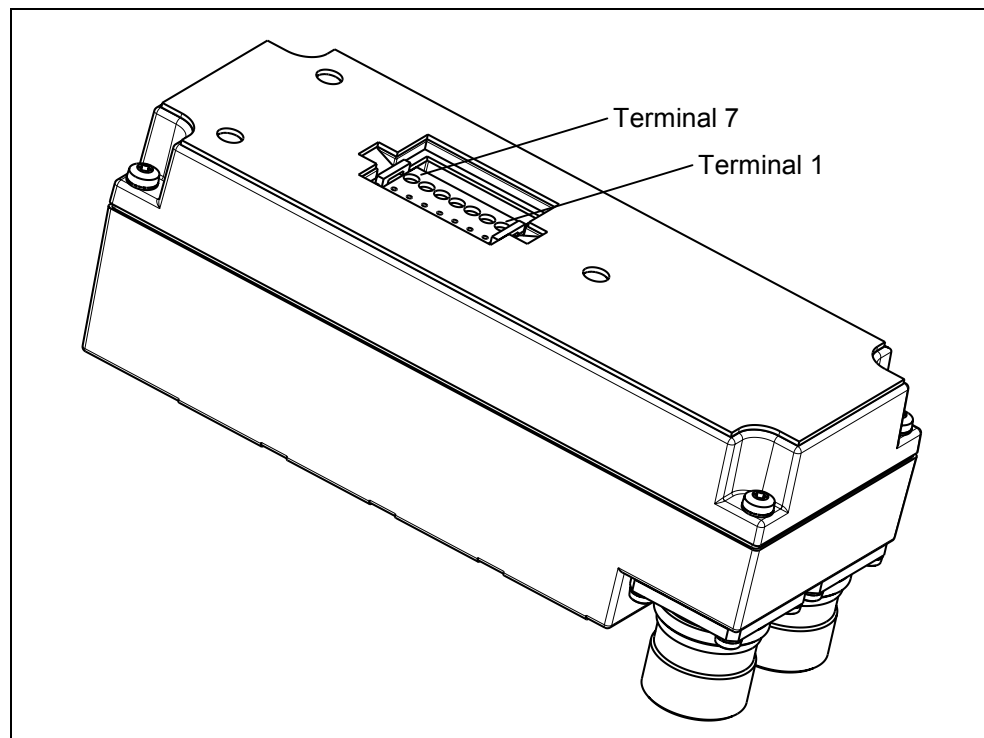

Figure 4-1 Floor cutout on welding module ET 200R-W

Table 4-1 Allocation of the terminal field on the back

Terminal No.	Signal / Function
1	24 V (US1, encoder power)
2	Digital input, bit 7 (parallel to X7, pin 2)
3	0 V (US1)
4	KSR_1
5	KSR_2
6	SKÜ_1
7	SKÜ_2

Removing

To remove the module, disconnect the terminal strip by lifting the ejector with a screwdriver either one side at a time or both sides at once.

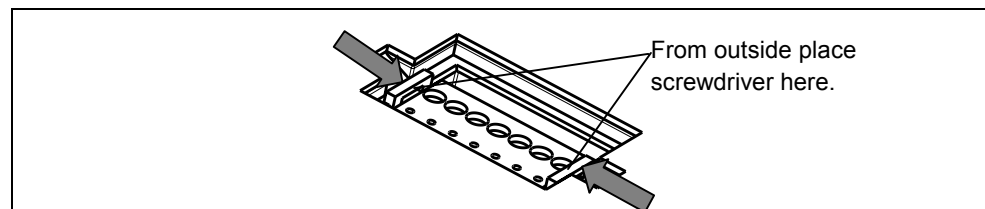

Figure 4-2 Ejector for the terminal strip

4.2.2 Connecting the bus plugs

Lightly press the cable plugs onto the cable socket and snap in the mechanical guide of the housing. Screw the swivel nuts hand-tight.

If the bus cable is not looped through further, cover X02 with a dummy cap (accessory) so that protection rating IP65 is ensured.

To remove proceed in reverse order.

Caution

Bus plug connectors X01 and X02 may only be connected or disconnected in the load-free operating state!

View of the contact side X01, X02 ET 200R

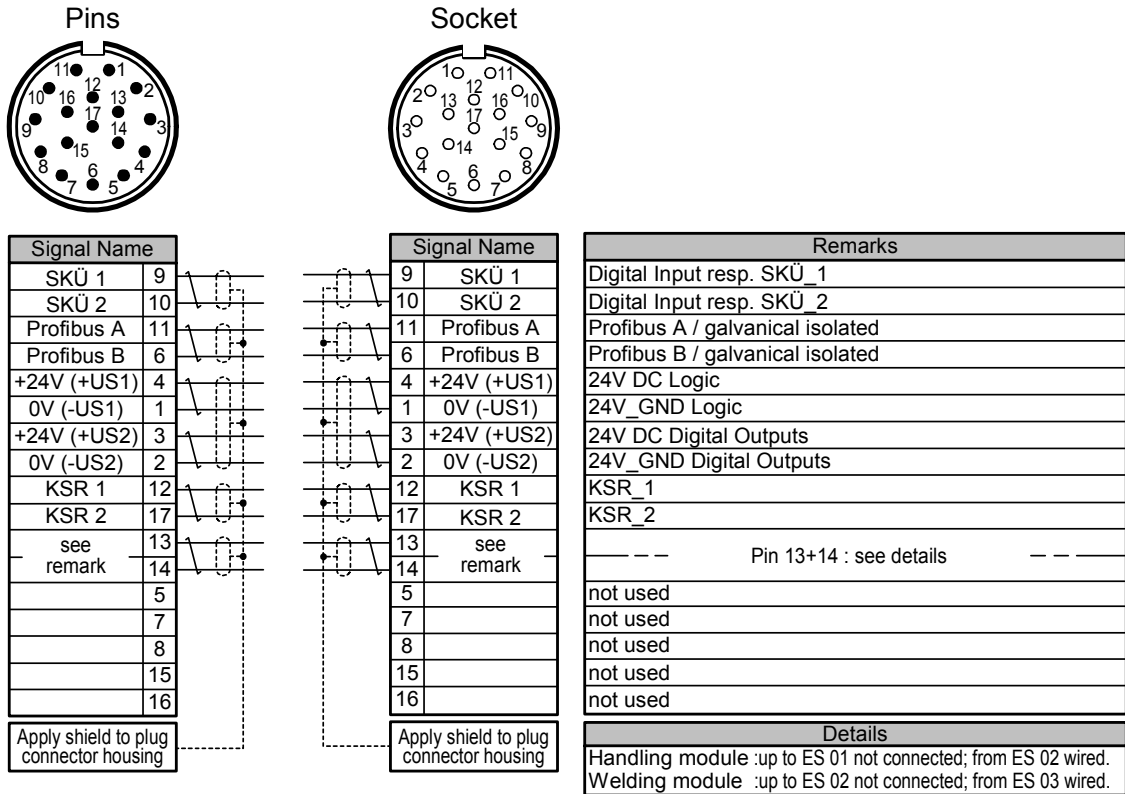

Figure 4-3 Allocation of plugs X01/X02

4.2.3 Plug connectors for the digital inputs and outputs

The digital inputs and outputs are connected to the 5-pin round socket (M12) on the front of the ET 200R. Another method is to use the 5-pin round coupling plug (M12) or Y connection pieces for the connection.

Mounting

Using light pressure press the actuator/sensor connector (M12) into the socket (X0 to X7) in the housing. Snap in the mechanical guide of the socket and hand-tighten the plug connector screw connection.

Cover unused sockets with a dummy cap.

To remove proceed in reverse order.

Wiring coupling plug M12

You will need the following to connect the digital inputs/outputs:

- one 5-pin, coupling plug connector (M12), can be fabricated,
- flexible, 3-, 4- or 5-core copper cable with a cross section of $\leq 0.75 \text{ mm}^2$

Wire the coupling plug as shown in the following pin allocation.

Table 4-2 Pin allocation of the coupling plug of the digital inputs/outputs (X0 to X7)

Pin	Allocation	View of Coupling Plug (Wiring Side))
1	24V (US1)	
2	DI/DO ¹⁾ (input/output signal)	
3	0 V (US1)	
4	DI/DO ¹⁾ (input/output signal)	
5	FE/shield	

1) With plug connectors X4 to X7: only DI

Closing unused sockets

Sockets which are not used must be closed with M12 covering caps so that protection rating IP65 is ensured.

Y connection piece

A Y connection piece permits double connection of actuators or sensors to the inputs or outputs of the ET 200R.

We recommend using a Y connection piece when 2 channels per socket of a module are being used. The Y connection piece divides the two channels into 2 coupling plugs (for pin allocation see tables 4-3 and 4-4).

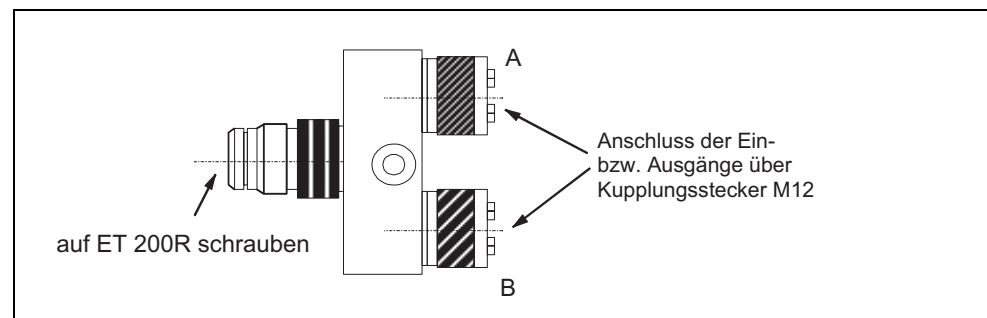

Figure 4-4 Y connection piece

Wire the two M12 coupling plugs for the Y connection piece as specified in the following pin allocation. The allocation of pin 4 of the Y connection piece depends on the socket of the ET 200R into which you will screw the Y connection piece.

Table 4-3 Pin allocation of the coupling plugs for digital inputs/outputs when the Y connection piece is used

Signal Name	X0 to X7 ¹⁾	Y Connection Plug	
		A	B
24V- (US1)	1	1	1
DI/DO	2	–	4
GND (US1)	3	3	3
DI/DO	4	4	–
FE/shield	5	5	5

1) See also table 4-2.

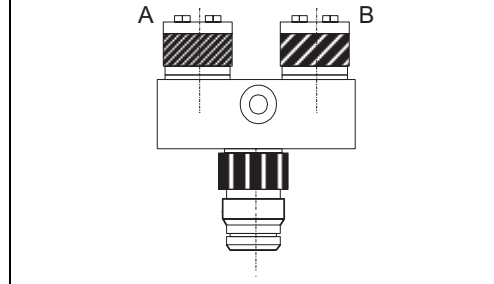

Note

To maintain protection rating IP65 all coverings must be screwed down correctly after wiring and setting have been performed.

5

Commissioning and Diagnosis

5.1 Configuring the ET 200R

Introduction

The channels of the ET 200R take their functionality from the parameters.

The following possibilities exist.

- Digital input/output on pins 2 and 4 of plug connectors X0 to X3
- Digital input on pins 2 and 4 of plug connectors X4 to X7

Configuration

The process image (PI) offers 2 bytes for inputs and 1 byte for outputs for the data transmission. Input and output areas may not have the same address in the process image.

Table 5–1 graphically shows the allocation of the digital inputs/outputs on the ET 200R to the bits of the inputs/outputs in the process image.

Table 5-1 Pin allocation of the sockets for 8-channel digital inputs

Steckerposition									
Plu designation.		X0	X1	X2	X3	X4	X5	X6	X7
Voltage supply	Pin 1	24 V DC							
	Pin 3	GND							
	Pin 5	Shield							
Input/Output	Pin 2	IN/OUT Bit 1	IN/OUT Bit 3	IN/OUT Bit 5	IN/OUT Bit 7	IN Bit 1	IN Bit 3	IN Bit 5	IN Bit 7 ¹⁾
Input/Output	Pin 4	IN/OUT Bit 0	IN/OUT Bit 2	IN/OUT Bit 4	IN/OUT Bit 6	IN Bit 0	IN Bit 2	IN Bit 4	IN Bit 6

1) When the ET 200R-W is used, allocated parallel to terminal strip X03, terminal 2

5.2 Commissioning and start up of the ET 200R

Software prerequisites for commissioning

Table 5-2 Software pre-requisites for commissioning the ET 200R

Configuration Software Used	Explanation
PROFIBUS-DP master configuration tool (e.g., COM PROFIBUS starting with version 2.1 or STEP 7)	You will have to link in the GSD file to COM PROFIBUS.

GSD file

A device master file (GSD file in accordance with EN 50170, volume 2) contains all slave-specific characteristics.

You can download the GSD file from the Internet.

You will find all GSD files under "Downloads" on the Internet page of SIMATIC Customer Support <http://www.ad.siemens.de/csi/gsd>

Hardware prerequisites

Table 5-3 Hardware pre-requisites for commissioning the ET 200R

Activities which have been completed	See ...
ET 200R mounted	Chapter 3.1
PROFIBUS address on DP slave set	Chapter 3.2
ET 200R wired	Chapter 3.3
ET 200R configured	Online aid/manual on configuration software
Power on	Manual on DP master

Startup of the ET 200R

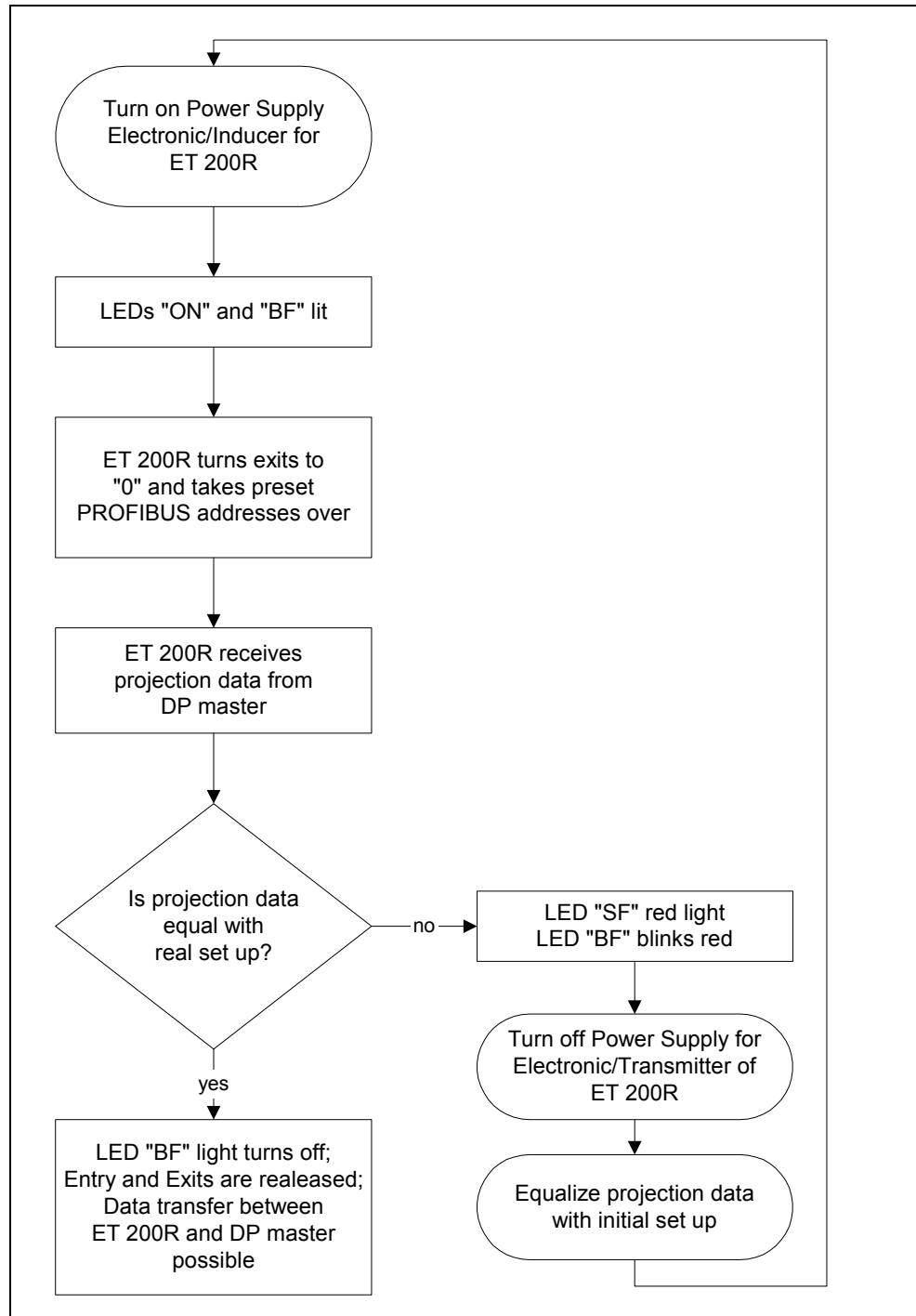

Figure 5-1 Startup of the ET 200R





5.3 Diagnosis with LED indicators

The ET 200R distributed I/O device has LEDs for indication of the status and errors.

Table 5-4 Allocation of the LEDs

Designation	Description	Color
BF	Bus error	Red
SF	Group error	Red
CH 01	Activity/service request, channel 01	Yellow
CH 02	Activity/service request, channel 02	Yellow
DC 24 V	Load voltage supply	green
ON	Voltage supply	green

Table 5-5 Status and error indicators on the ET 200R

 LED on
  LED off
  LED flashing
  Disregard

























LEDs			Meaning	Remedy
BF	SF	ON		
			<ul style="list-style-type: none"> There is either no power for the electronics/encoder on the DP slave or there is not enough power. Hardware is defective. 	<ul style="list-style-type: none"> Turn on the power for the DP slave. Check the power. Replace the ET 200R.
			<ul style="list-style-type: none"> The ET 200R is on. 	–
			<ul style="list-style-type: none"> ET 200R is starting up. The connection to the DP master has broken down. ET 200R does not recognize baud rate. Bus interruption. DP master is out of order. 	<ul style="list-style-type: none"> Check the PROFIBUS-DP-connection. Check the DP master. Check all cables in your PROFIBUS-DP network. Check to determine whether the bus plug connections are securely connected on the ET 200R.
			<ul style="list-style-type: none"> The PROFIBUS address set on the ET 200R is wrong. The ET 200R has a hardware defect. 	<ul style="list-style-type: none"> Correct the PROFIBUS address on the ET 200R. Replace ET 200R.
			<ul style="list-style-type: none"> The configuration data sent by the DP master to the ET 200R do not match the actual layout of the ET 200R. 	<ul style="list-style-type: none"> Check the configuration of the DP slave (input/output, PROFIBUS address).

Table 5-5 Status and error indicators on the ET 200R

 LED on
  LED off
  LED flashing
  Disregard

LEDs			Meaning	Remedy
BF	SF	ON		
			<ul style="list-style-type: none"> ET 200R recognizes the baud rate but is not addressed by the DP master. ET 200R was not configured. 	<ul style="list-style-type: none"> Check the PROFIBUS address set on the ET 200R or in the configuration software. Check the configuration of the ET 200R.
CH 01	CH 02	Meaning		Remedy
 yellow	 yellow	<ul style="list-style-type: none"> Activity/data communication on the bus segments. 		–

SF-LED

The ET 200R device's red group error LED (SF) goes on as soon as a diagnostic event occurs. The SF LED does not go off again until the diagnostic event has departed.

24V DC LED

The 24 V DC LED goes on when the ET 200R is connected to a load voltage power supply.

Status indicator

In addition the module of the ET 200R has a status indicator for each input and output. The LEDs go on when the inputs or outputs are activated.

5.4 Diagnostic messages

Slave diagnosis

The slave diagnosis conforms to standard EN 50170, volume 2 (EN 61158), PROFIBUS. Depending on the DP master it can be read for all slaves which conform to the standard.

The next few sections describe what the slave diagnosis covers and how it is read out.

Depending on the DP master and the parameterization ET 200R devices offer an expanded diagnosis.

5.4.1 Reading the Diagnosis

Ways to read the diagnosis

Table 5-6 Reading the diagnosis from the ET 200R

Programmable Controller with DP Master	Use	See...
SIMATIC S5 with IM 308-C as DP master.	Read slave diagnosis (store in data area of the user program).	For layout, see chapter 5.5.2. For FB, see manual on distributed I/O system ET 200.
SIMATIC S5 with S5-95U as DP master.		
CP5614		
SIMATIC S7 300 / 400		

5.5 Layout of the ET 200R slave diagnosis

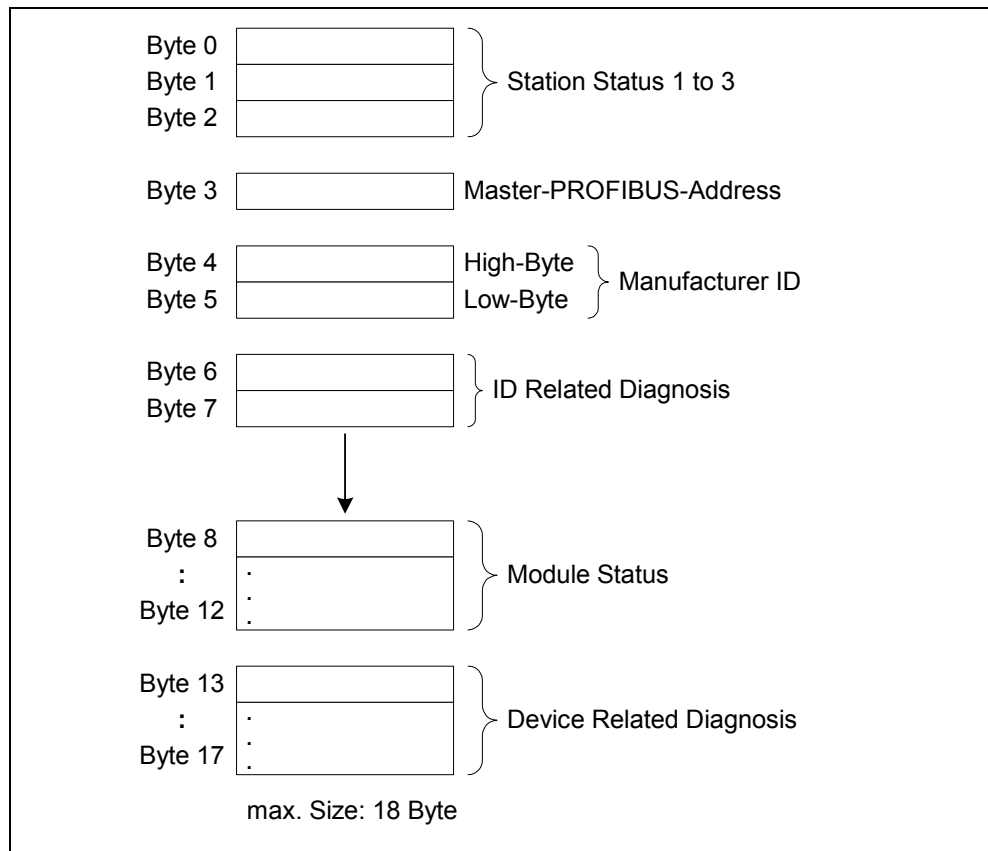

Figure 5-2 Layout of the ET 200R slave diagnosis

5.5.1 Station status 1 to 3

Definition

Station status 1 to 3 gives you an overview of the status of a DP slave.

Station status 1

Table 5-7 Layout of station status 1 (byte 0), ET 200R

Bit	Meaning	Cause/Remedy
0	1: The DP slave cannot be addressed by the DP master. The bit on the DP slave is always 0.	<ul style="list-style-type: none"> Is the right PROFIBUS address set on the DP slave? Are bus connection plugs/fiber-optic conductors connected? Does the DP slave have power? Is the RS 485 repeater set correctly? Perform reset on DP slave (power off/on)?
1	1: The DP slave is still not ready for data communication.	<ul style="list-style-type: none"> Wait until DP slave has finished startup.
2	1: The configuration data sent to the DP slave by the DP master do not match the actual layout of the DP slave.	<ul style="list-style-type: none"> Has the correct station type or correct layout of the DP slave been entered in the configuration software?
3	1: An external diagnosis exists.	<ul style="list-style-type: none"> Evaluate the ID-related, the module status and/or the device-specific diagnosis. As soon as all errors have been corrected, bit 3 is re-set. The bit is set again when a new diagnostic message is entered in the bytes of the above diagnoses.
4	1: The required function is not supported by the DP slave (e.g., SYNC/FREEZE).	<ul style="list-style-type: none"> Check the configuration.
5	1: The bit is always 0.	<p>NOTE</p> <p>Is the bit 1 when the station status is read by the DP master? DP master is unable to interpret the response of the DP slave.</p>
6	1: The DP slave type does not match the software configuration.	<ul style="list-style-type: none"> Compare the "should be" configuration with the "actual" configuration.
7	1: The DP slave has been parameterized by another DP master (not by the DP master which currently has access to the DP slave).	<ul style="list-style-type: none"> Bit is always 1 if, for example, you are just accessing the DP slave with the PG or another DP master. The PROFIBUS address of the DP master which parameterized the DP slave can be found in the "master PROFIBUS address" diagnostic byte.

Station status 2

Table 5-8 Layout of station status 2 (byte 1), ET 200R

Bit	Meaning
0	1: The DP slave must be parameterized again.
1	1: A diagnostic message exists. The DP slave will not function until the error is corrected (static diagnostic message).
2	1: The bit on the DP slave is always 1.
3	1: Address monitoring is activated for this DP slave.
4	1: The DP slave received the control command "FREEZE."
5	1: The DP slave received the control command "SYNC."
6	0: Bit is always 0.
7	1: Bit is always 0. NOTE While the DP master reads the station status, the bit is 1 if the DP slave was deactivated on the DP master (i.e., it is not included in current processing).

Station status 3

Table 5-9 Layout of station status 3

Bit	Meaning
0 bis 6	0: Bits are always 0.
7	1: More device-specific diagnostic messages exist than can be presented in the diagnostic telegram.

5.5.2 Master PROFIBUS address

Definition

Diagnostic byte 3 contains the PROFIBUS address of the DP master

- that parameterized the slave and
- that has read and write access to the DP slave.

FF_H in byte 3

If byte 3 shows the master PROFIBUS address as FF_H, the DP slave has not been parameterized by the DP master.

5.5.3 Manufacturer's ID

Definition

The manufacturer's ID contains a code which describes the type of DP slave.
The manufacturer's ID for the ET 200R distributed I/O device is 80A8_H.

5.5.4 ID-related diagnosis

Definition

The ID-related diagnosis indicates whether an error occurred on the ET 200R.
The ID-related diagnosis starts at byte 6 and contains 2 bytes.

The ID-related diagnosis for the ET 200R is organized as shown below.

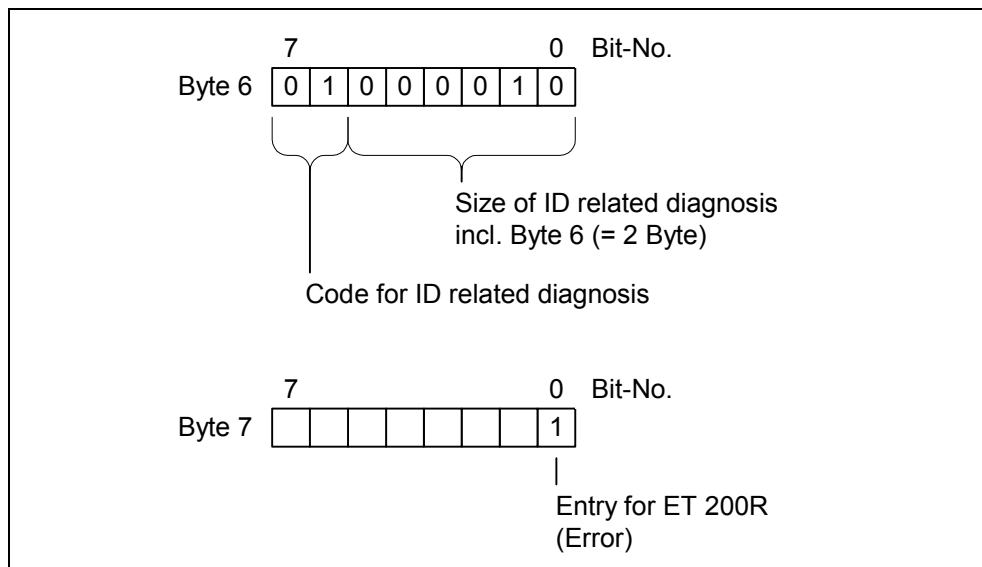

Figure 5-3 Layout of the ID-related diagnosis for ET 200R

5.5.5 Module status

Definition

The module status provides the status of the configured modules and gives detailed information on the ID-related diagnosis with regard to configuration. The module status begins after the ID-related diagnosis and contains 5 bytes.

The telegram only contains the module status if you enabled the "expanded diagnosis" during parameterization.

The module status for the ET 200R is organized as shown below.

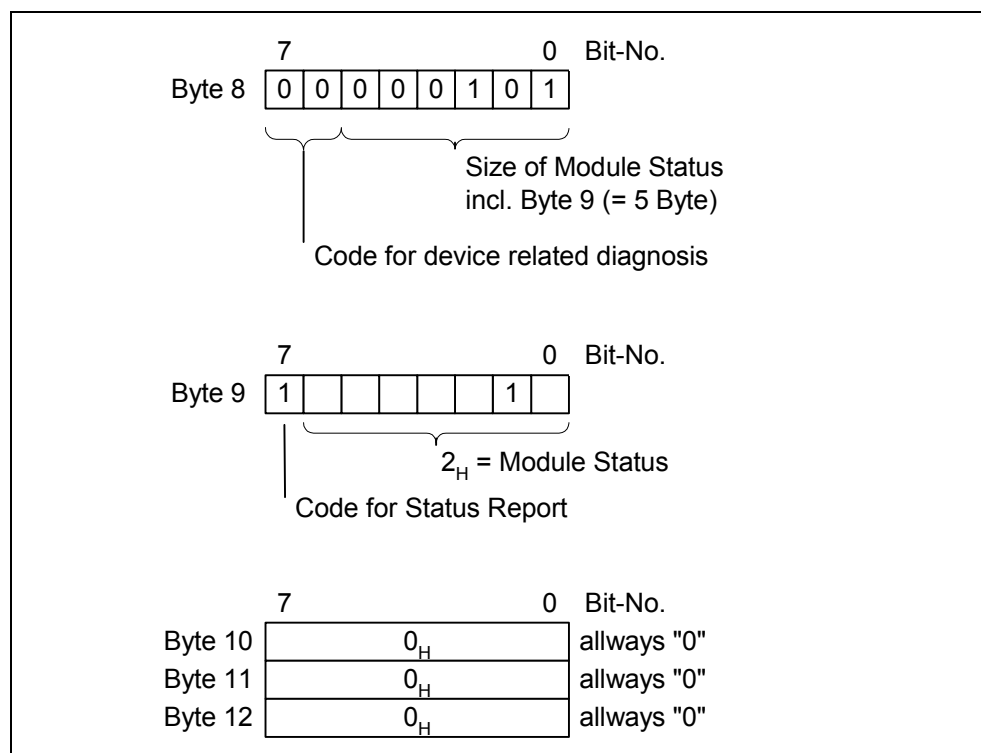

Figure 5-4 Layout of the module status for the ET 200R

5.5.6 Device-specific diagnosis

Definition

The device-specific diagnosis provides information on the channel errors of modules and gives you detailed information on the ID-related diagnosis.

The device-specific diagnosis begins after the module status.

The device-specific diagnosis does not affect the module status.

Device-specific diagnosis

Important: The diagnostic alarm must be activated for each module!

The device-specific diagnosis only appears in the diagnostic telegram if you enabled the "expanded diagnosis" during parameterization.

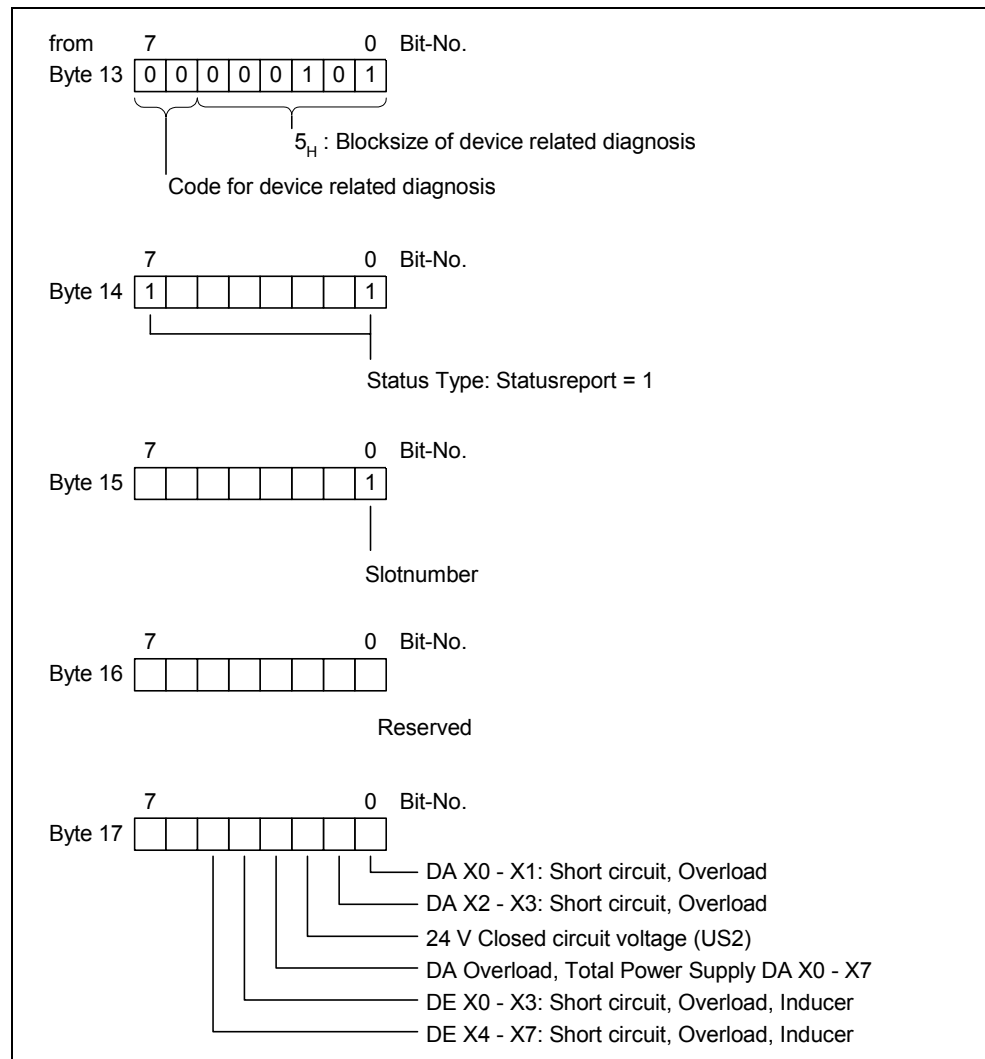

Figure 5-5 Layout of the device-specific diagnosis

General Technical Data

6

The general technical data contain the standards and test values which the ET 200R distributed I/O device fulfills and the test criteria used to test the ET 200R distributed I/O device.

6.1 Standards and Certifications

This chapter contains

- the most important standards whose criteria the ET 200R fulfills and
 - the certifications for the ET 200R
- for the components of the ET 200R.

PROFIBUS standard

The ET 200R distributed I/O device is based on the standard EN 50170, volume 2 (IEC 61158), PROFIBUS.

CE seal

Our products meet the requirements and protection goals of the following EG guidelines and correspond to the harmonized European standards (EN) published for programmable controllers in the official documents of the European Community:

- 89/336/EWG, electromagnetic compatibility (EMC guidelines)
- 73/23/EWG, electrical resources for use within certain voltage limits (guidelines on low voltage).

EG statements of conformity are kept on file for the responsible authorities at the address below:

Siemens Aktiengesellschaft
Automation & Drives
A & D SE
Postfach 2355
D-90766 Fürth

cULus-Certifikation

UL listing mark
 Underwriters Laboratories (UL) in acc. w.
 standard UL 508, file no. 120 869
 CSA C22.2 No. 14-95

6.2 Electromagnetic compatibility

Definition

Electromagnetic compatibility is the capability of an electrical system to function satisfactorily in its electromagnetic environment without disturbing its surroundings.

The ET 200R distributed I/O device also fulfills, among others, the requirements of the EMC law of the European domestic market.

Prerequisite for this: The cabling must be made in accordance with the specifications and guidelines of electrical setup.

Pulse-shaped interference

The following table shows the electromagnetic compatibility of the ET 200R distributed I/O device in the presence of pulse-shaped interference.

Pulse-Shaped Interference	Test with
Electrostatic discharge in acc. with IEC 61000-4-2	± 4 kV (contact discharge) ± 8 kV (air discharge)
Burst pulses (fast transient interference) in acc. with IEC 61000-4-4	1 kV (signal line) 2 kV (power supply)
Surge (single high-powered pulse) in acc. with IEC 801-5 (DIN VDE 0839, part 10). Only with external lightning protection elements (see manual of the DP master).	
Asymmetrical coupling	2 kV (signal line) 2 kV (power supply)
Symmetrical coupling	1 kV (signal line) 1 kV (power supply)

Sine-shaped interference

The following table shows the electromagnetic compatibility of the ET 200R distributed I/O device in the presence of sine-shaped interference.

HF Radiation in Acc. w. IEC 61000-4-2		HF Coupling in Acc. w. IEC 61000-4-6
Amplitude-Modulated	Pulse-Modulated	
80 to 1000 MHz	900 MHz to 1,89 GHz	0,15 to 80 MHz
10 V/m		10 V _{eff} unmodulated
80 % AM (1 kHz)	50 % ED	80 % AM (1 kHz)

Emission of radio interference

Interference emission of electromagnetic fields in accordance with EN 55011: Limit value class A, group 1 (measured at distance of 10 m).

Frequency	Interference Emission
30 to 230 MHz	40 dB (µV/m)Q
230 to 1000 MHz	47 dB (µV/m)Q

6.3 Physical and Climatic Ambient Conditions

Transportation and storage conditions

With regard to transportation and storage conditions the ET 200R distributed I/O device exceeds the requirements of IEC 61131, part 2. The following information applies to modules which are transported or stored in their original packaging.

Type of Condition	Permissible Range
Free fall	1 m
Temperature	-40 °C to +70 °C
Temperature change	3 K/min
Air pressure	Not tested
Relative humidity	Up to 95 %, no Condensation

Physical ambient conditions

The physical ambient conditions are specified in the following table with sine-shaped oscillations. The ET 200R module is secured on the base. The test was performed in accordance with IEC 60068-2-6

Frequency Range	Displacement	Acceleration	Cycles/Axis	Oktaves/ Minutes
5 to 11 Hz	15 mm	-	10	1
10 to 150 Hz	-	5 g	10	1

Shock during operation

The following table specifies permissible shock during operation. The test was performed in accordance with IEC 60068-2-27.

Shock Duration	Shock Form	Acceleration	Amount
11 msec	Half sine	15 g	3 shocks each in +/- direction in each of the 3 vertical axes

Climatic ambient conditions

The following climatic ambient conditions apply.

Table 6-1 Ambient conditions

Ambient Condition	Application Area	Remarks
Temperature	From 0 ° to 55 °C	
Temperature change	3 K/min	
Air pressure		Not tested
Relative humidity	Up to 95%	No condensation
Concentration of - pollutants	SO ₂ : < 0,5 ppm; rel. humidity < 60%, no condensation H ₂ S: < 0,1 ppm; rel. humidity < 60%, no condensation	Test: 10 ppm; 4 days 1 ppm; 4 days

6.4 Information on isolation tests, protection class, protection rating and nominal voltage of the ET 200R

Protection rating, IP65

IP65 protection rating in accordance with IEC 529 for the ET 200R distributed I/O device

- Protection against dust and total protection against accidental touch
- Protection against jet of water from a nozzle directed from all sides at the housing. The water may not cause damage.

Note

The above protection ratings only apply when the ET 200R is completely closed.

Close all unused plugs with the appropriate protective caps.

Technical Data

7

This chapter gives you the technical data for the ET 200R distributed I/O device.

Characteristics

The ET 200R distributed I/O device offers the following characteristics.

- 8 digital inputs (fixed)
- 8 digital inputs/outputs (can be parameterized)
- Nominal input voltages: 24 V DC
- Suitable for switches and proximity switches.

Closing unused connections

Connections which are not used must be closed with covering caps (M12 or M23) so that protection rating IP65 is ensured.

Technical data for the ET 200R

Table 7-1 Technical data

General	
Dimensions (W x L x H) in mm	54 x 150 x 55 (64 mm incl. plug height))
Protection rating	IP 65
Housing material I	Cast aluminum
Number of channels	16 process channels 8 DI, fixed 8 DI/DO, parametrizable
Connection of the channels	Eight 5-pin, round plug connectors (M12x1)
Ambient temperature	55 °C
Relative humidity	Up to 95 %, no Condensation
Voltage	
Nominal value	DC 24 V (-15/+20 %)
Electronic fuse	yes
Protection against pole reversal	yes
Line length	
Unshielded for signal lines	max. of 10 m
Shielded bus line	max. of 30 m per branch
Digital Inputs	
Encoder power, 8 channels each	max. 0.5 A
Signal 1	+15 V to +30 V
Signal 0	-3 V to +5 V
Input current for signal 1	7 mA (typ.)
Input characteristic curve	In acc. with IEC 1131, type 2. Also connection of 2-wire proximity switches
Input delay	3 msec (typ.)
Digital Outputs	
Number of channels	max. of 8
Output current per channel	max. of 0,5 A
Total output current	max. of 2 A (up to 55 °C)
Switching frequency	100 Hz
Short circuit proof	yes, electronics
Safety circuit	Integrated free-wheeling diode
Connection of bus and power	
X01/X02	2 x M23 (17-pin)
Max. current, US1, per pin Max. current, US2, per pin Max. total current, US1 + US2	9 A 9 A 13 A (up to 55 °C) 18 A (up to 45 °C)

Table 7-1 Technical data

Diagnosis	
Diagnostic telegrams	yes
Optical indication on module	yes, with SF LED
Missing load voltage	yes
Short circuit of encoder power	Per group, X0 to X3 or X4 to X7
Short circuit of digital outputs	yes
Indications on module	
Status indication, DI/DO, per channel	yes
Function LED	BF SF Channel 01 Channel 02 ON (logic/encoder voltage) US1 DC24 Volt (load voltage) US2
Pin allocation, X01/X02	
Pin 1	0V (US1)
Pin 2	0V (US2)
Pin 3	24V (US2)
Pin 4	24V (US1)
Pin 5	not used
Pin 6	PROFIBUS B
Pin 7	not used
Pin 8	not used
Pin 9	SKÜ 1
Pin 10	SKÜ 2
Pin 11	PROFIBUS A
Pin 12	KSR 1
Pin 13	not used
Pin 14	not used
Pin 15	not used
Pin 16	not used
Pin 17	KSR 2
Pin allocation, terminal field on the back, X03	
Actuator/sensor channels 0 to 7 (plugs X0 to X3)	
Pin 1	24V US1
Pin 2	DI/DO
Pin 3	0V US1
Pin 4	DI/DO
Pin 5	FE/shield
Actuator/sensor channels 8 to 15 (plugs X4 to X7)	
Pin 1	24V US1
Pin 2	DI
Pin 3	0V US1
Pin 4	DI
Pin 5	FE/shield
Certifications	
PROFIBUS	yes; galvanical isolated
CE	yes
UL/CSA	Under preparation

Appendix

A

Ordering information

The ET 200R distributed I/O device is available in two models.

Handling module	ET 200R-H	6ES7 143 2BH00 0AB0
Welding module	ET 200R-W	6ES7 143 2BH50 0AB0

Accessories

	Order Designation	Order Address
Hybrid cable	EHRK9711Rev.0	elocab Sonderkabel GmbH Obere Lerch 34 91166 Georgensgmünd
Terminal strip for connection of the signals on the terminal field on the back	25.600.5753.0	Wieland; elektronische Verbindungen Brennerstraße 10-14 96052 Bamberg Tel.: 0951/9324-0
Covering cap, M12	08-1136.000-000	Franz Binder GmbH Roetelstraße 27 74172 Bad Neckarsulm Tel.: 07132/325-0
Covering cap, M23	C/BEL/1	Hypertac GmbH Ulrichsberger Str. 17 94469 Deggendorf Tel.:0991/25012-62
Signal plug	SPFA17GMRSN170	
Signal socket	SPFA17HFRON170	

