

BA 33.0001  
465 520 EN

# Lenze

## *Operating Instructions*

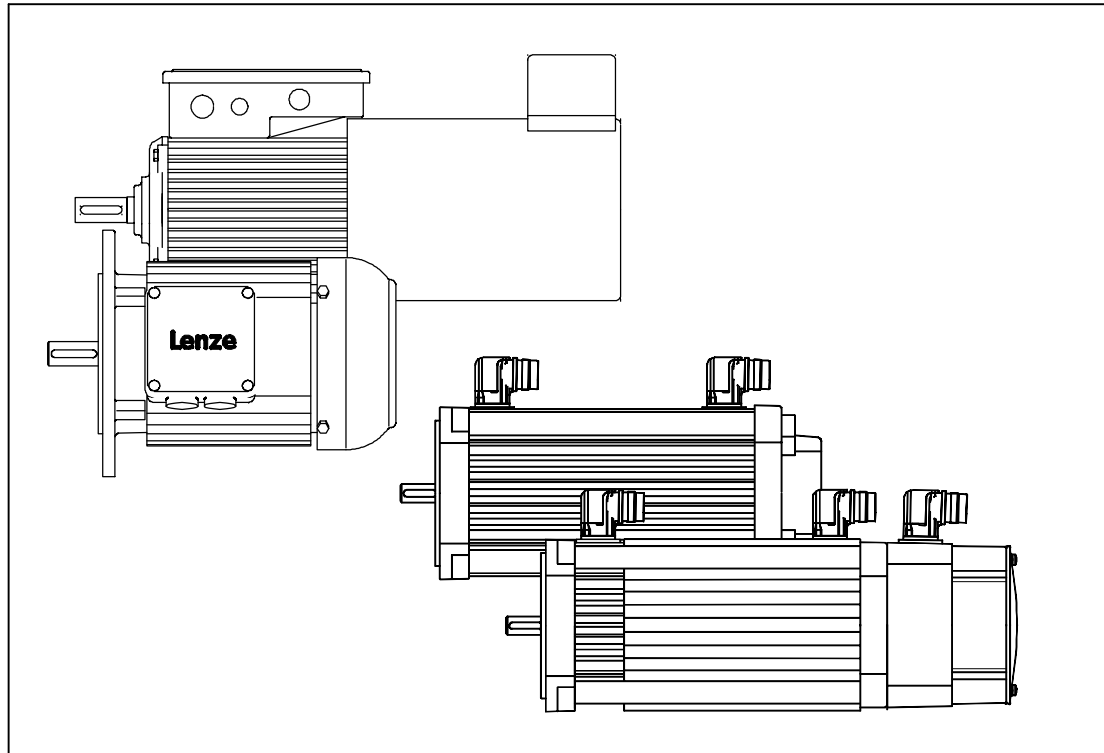

### ***Global Drive***

*Servo motors*

*MDXK, MDFQ, MCS*

*Three-phase motors MDXM*

The Operating Instructions are valid for servo motors and three-phase motors with the nameplate designation - see page 3





## What is new, what has been changed ?

Material no.	Edition	Important	Content
408 498	1.0 03/97	1 <sup>st</sup> edition	Operating Instructions MDXKX servo motors
408 498	2.0 03/99	2 <sup>nd</sup> edition replaces 1st edition	<ul style="list-style-type: none"> <li>• Common Operating Instructions MDXK, MDFQ, MDXM</li> <li>• Completely revised</li> <li>• Completely revised</li> </ul>
465 520	1.0 03/03 TD09	1 <sup>st</sup> edition replaces 408 498	<ul style="list-style-type: none"> <li>• New servo motor type: MCS</li> <li>• Completely revised</li> <li>• Chapter 3.1.4 new: Assembly of motors at gearboxes with bearing flange</li> <li>• PG gland replaces metric thread</li> </ul>





© 2002 Lenze Drive Systems GmbH

No part of this documentation may be reproduced or made accessible to third parties without written consent by Lenze Drive Systems GmbH. All indications given in these Operating instructions have been selected carefully and comply with the hardware and software described. Nevertheless, deviations cannot be ruled out. We do not take any responsibility or liability for damages which might possibly occur. Required corrections will be included in updates of this documentation.

### Safety information

-  Hazardous voltage at power connections, posing danger to life even if the connector is withdrawn: Residual voltage > 60V!  
It is absolutely vital to disconnect the controller from the mains and to wait until the motor has come to a standstill before working on the power connections (voltage at contacts while motor is rotating).
-  Danger of getting burned!  
Hot surfaces during operation, up to 140°C! Provide touch guards.
-  Danger of getting hurt by rotating shaft!  
Wait until motor has come to standstill before working on it.
-  Never withdraw the connector while live!  
Otherwise it may be destroyed. Inhibit controller before withdrawing the connector.

### Assembly

-  First read Operating Instructions before you start!
- 
  - Use appropriate means of transport!
  - Avoid impacts on the shaft! Motor can be destroyed! Assemble output elements only via thread in the motor shaft, dismantle with pull-off device. Firmly tighten clutch.
  - Securely mount motor, ensure unimpeded ventilation
  - Open bores for condensation if necessary
  - Firmly tighten union nuts of the connectors
- 
  - Carefully ground motor, check wiring
  - Apply screens of motor cable over a large surface at the motor and controller
- 
  - Maintenance interval of shaft seal: approx. 2,500 h
  - Maintenance interval at roller bearing: approx. 15,000 h
  - Clean motor at regular intervals

BA 33.0001

Author: Lenze Drive Systems GmbH

1st edition: 03/03

## Structure of type code for servo motors and three-phase motors

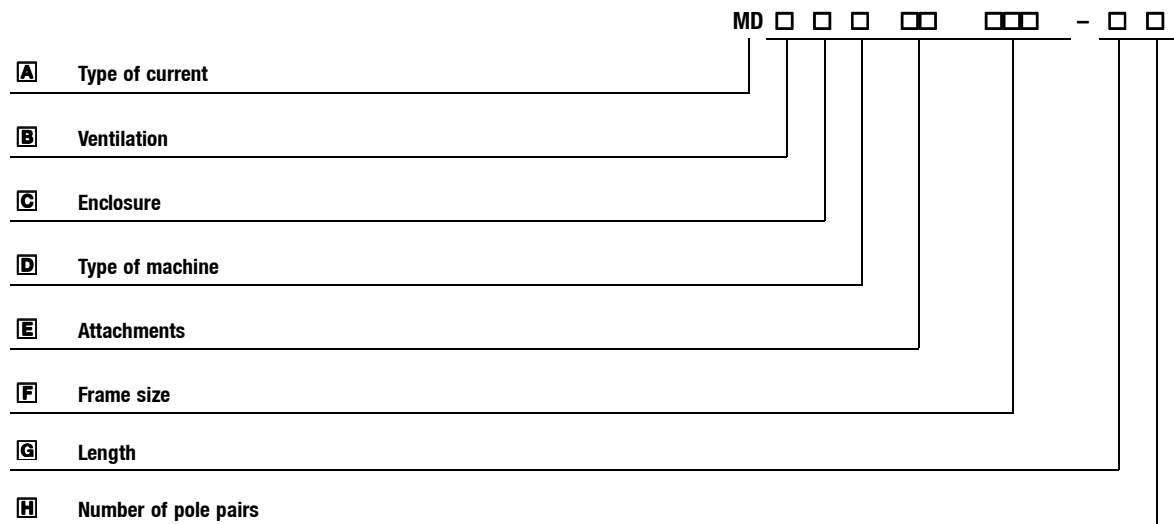

## Structure of type code for compact servo motors MCS

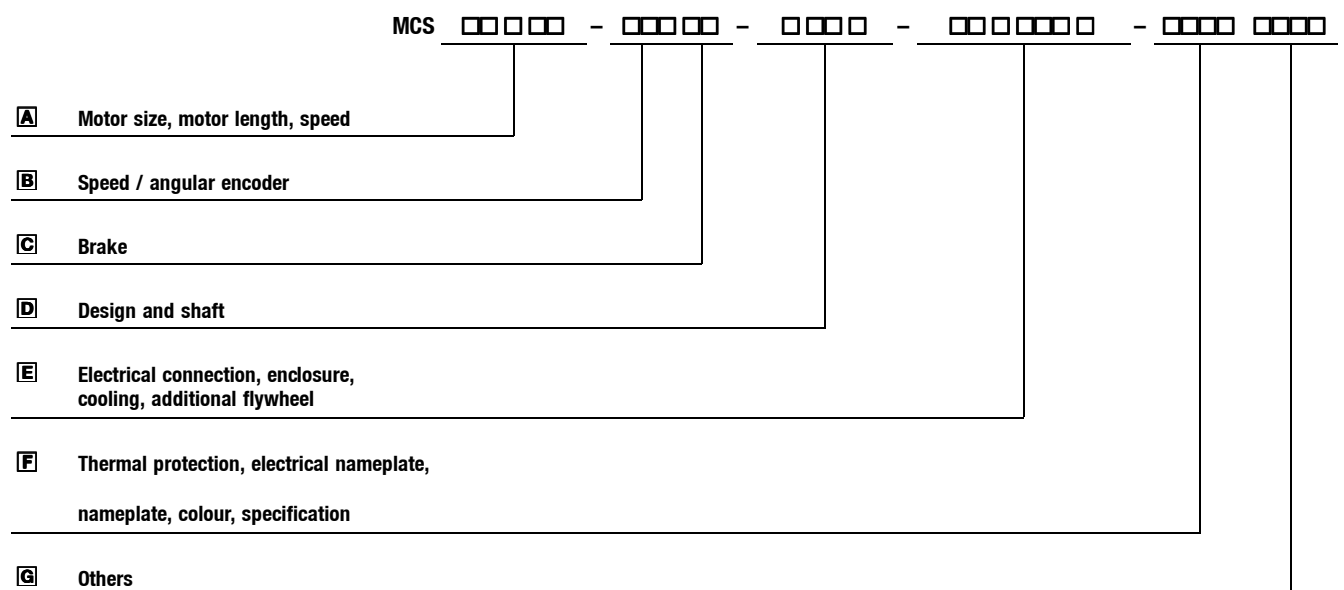

## Legend of type code servo motor and three-phase motor type code

### **A**

D = Three-phase AC

### **B**

F = Forced ventilation

S = Natural ventilation (cooling by convection and radiation)

E = Self ventilation

### **C**

M = Modular three-phase AC motor

K = Compact servo motor with square housing and cooling ribs

Q = IP23 servo motor with square housing

### **D**

A = Asynchronous machine

S = Synchronous machine

### **E**

AG = Absolute value encoder

BA = Brake and sin-cos-absolute value encoder or SSI-absolute value encoder

BG = Brake, resolver and incremental encoder

BI = Brake and incremental encoder (pulse encoder)

BR = Brake

BS = Brake and resolver

BW = Brake, resolver and absolute value encoder

BX = Brake, encoder prepared

GX = No brake, encoder prepared

NN = No brake, no encoder

IG = Incremental encoder (pulse encoder)

RA = Resolver and absolute value encoder

RI = Resolver and incremental encoder

RS = Resolver

## Legend of compact servo motor type code

### **A**

06 = Side length 62mm

09 = Side length 89mm

12 = Side length 116mm

14 = Side length 142mm

C...P = Length

XX = Speed in 100 min<sup>-1</sup>

### **B**

RS0 = Resolver p=1

SRS = Single-turn absolute value encoder with sin-cos-signals, Hiperface

SRM = Multi-turn absolute value encoder with sin-cos-signals, Hiperface

ECN = Single-turn absolute value encoder with sin-cos-signals, Endat

EQN = Multi-turn absolute value encoder with sin-cos-signals, Endat

CDD = Incremental encoder with commutation signals TTL with UVW

**C**

- B0 = without brake
- F1 = Spring-applied brake 24V-DC
- P1 = PM brake 24V-DC
- P2 = PM brake 24V-DC reinforced

**D**

- A = Standard flange form A / FF with through-bores, cylindrical shaft without key
- B = Standard flange form A / FF with through-bores, cylindrical shaft with key
- C = Standard flange form C / FT with through-bores, cylindrical shaft without key
- N = Standard flange form C / FT with through-bores, cylindrical shaft with key (standard attachment)
- E = Standard flange form A / FF with through bores, shaft with involute gearing (specify special, module...)
- 11 = Shaft 11x23 (MCS06)
- 14 = Shaft 14x30 (MCS09)
- 19 = Shaft 19x40 (MCS12)
- 24 = Shaft 24x50 (MCS14)
- N or R = Smooth running / vibration strength
- Z0X attachment without cover, with cone hollow shaft; cone shaft MCS06...MCS14

**E**

- ST = Separate round connectors for power / brake, encoder / temperature, fan
- SQ = Joint rectangular connector for power, encoder ....
- KK = Terminal box for power / brake, encoder / temperature, fan
- KS = Terminal box for power / brake / fan and connection for encoder / temperature
- 5 = IP54 without shaft seal (except for direct gearbox attachment)
- 6 = IP65 with shaft seal
- S00 = Self-cooling / without fan
- N = without additional flywheel
- J = with additional inertia

**F**

- R = Thermal protection KTY sensor
- 0 = standard nameplate
- 2 = Second nameplate loosely attached
- 6 = US nameplate
- 8 = Second US nameplate loosely attached
- S = Colour black
- O = Specification - standard
- U = Specification - UL version, UR approval

## Nameplates of MCS-KUKA motors

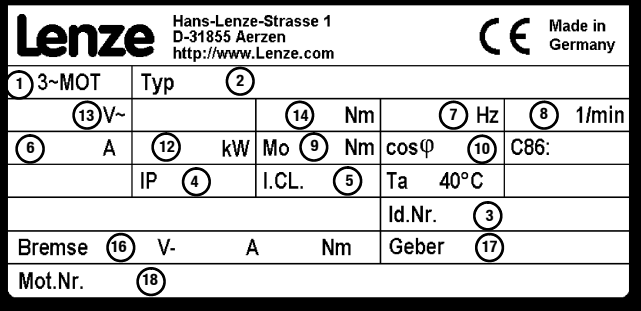
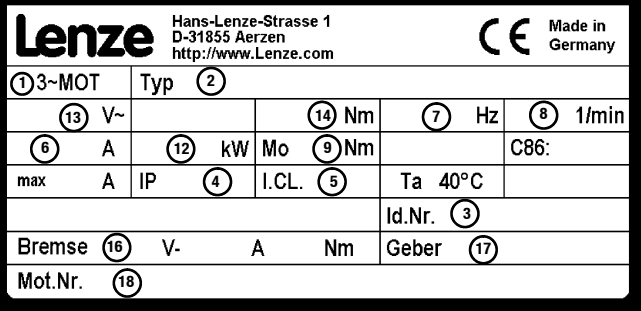
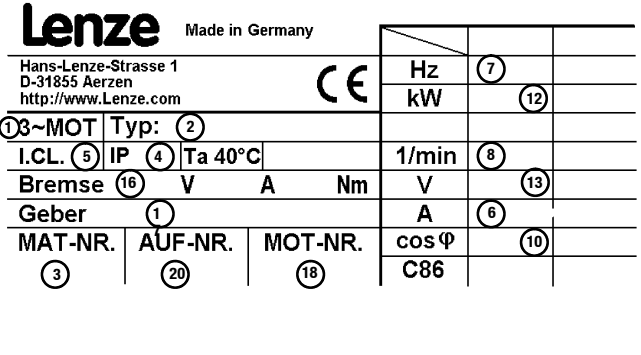
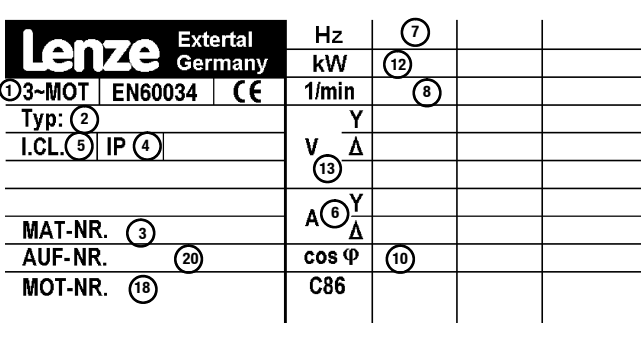
MDXKA asynchronous servo motors	Synchronous servo motors MDXKS / CFS																																																																																																
 <p><b>Lenze</b> Hans-Lenze-Strasse 1 D-31855 Aerzen http://www.Lenze.com <b>CE</b> Made in Germany</p> <table border="1"> <tr> <td>① 3~MOT</td> <td>Typ ②</td> <td>⑬ V~</td> <td>⑭ Nm</td> <td>⑦ Hz</td> <td>⑧ 1/min</td> </tr> <tr> <td>⑥ A</td> <td>⑫ kW</td> <td>Mo ⑨ Nm</td> <td>cos φ</td> <td>⑩ C86:</td> <td></td> </tr> <tr> <td></td> <td>IP ④</td> <td>I.CL. ⑤</td> <td>Ta 40°C</td> <td></td> <td></td> </tr> <tr> <td></td> <td></td> <td></td> <td>Id.Nr. ③</td> <td></td> <td></td> </tr> <tr> <td>Bremse ⑯ V-</td> <td>A</td> <td>Nm</td> <td>Geber ⑰</td> <td></td> <td></td> </tr> <tr> <td>Mot.Nr. ⑱</td> <td></td> <td></td> <td></td> <td></td> <td></td> </tr> </table>	① 3~MOT	Typ ②	⑬ V~	⑭ Nm	⑦ Hz	⑧ 1/min	⑥ A	⑫ kW	Mo ⑨ Nm	cos φ	⑩ C86:			IP ④	I.CL. ⑤	Ta 40°C						Id.Nr. ③			Bremse ⑯ V-	A	Nm	Geber ⑰			Mot.Nr. ⑱						 <p><b>Lenze</b> Hans-Lenze-Strasse 1 D-31855 Aerzen http://www.Lenze.com <b>CE</b> Made in Germany</p> <table border="1"> <tr> <td>① 3~MOT</td> <td>Typ ②</td> <td>⑬ V~</td> <td>⑭ Nm</td> <td>⑦ Hz</td> <td>⑧ 1/min</td> </tr> <tr> <td>⑥ A</td> <td>⑫ kW</td> <td>Mo ⑨ Nm</td> <td>cos φ</td> <td>⑩ C86:</td> <td></td> </tr> <tr> <td>max</td> <td>IP ④</td> <td>I.CL. ⑤</td> <td>Ta 40°C</td> <td></td> <td></td> </tr> <tr> <td></td> <td></td> <td></td> <td>Id.Nr. ③</td> <td></td> <td></td> </tr> <tr> <td>Bremse ⑯ V-</td> <td>A</td> <td>Nm</td> <td>Geber ⑰</td> <td></td> <td></td> </tr> <tr> <td>Mot.Nr. ⑱</td> <td></td> <td></td> <td></td> <td></td> <td></td> </tr> </table>	① 3~MOT	Typ ②	⑬ V~	⑭ Nm	⑦ Hz	⑧ 1/min	⑥ A	⑫ kW	Mo ⑨ Nm	cos φ	⑩ C86:		max	IP ④	I.CL. ⑤	Ta 40°C						Id.Nr. ③			Bremse ⑯ V-	A	Nm	Geber ⑰			Mot.Nr. ⑱																													
① 3~MOT	Typ ②	⑬ V~	⑭ Nm	⑦ Hz	⑧ 1/min																																																																																												
⑥ A	⑫ kW	Mo ⑨ Nm	cos φ	⑩ C86:																																																																																													
	IP ④	I.CL. ⑤	Ta 40°C																																																																																														
			Id.Nr. ③																																																																																														
Bremse ⑯ V-	A	Nm	Geber ⑰																																																																																														
Mot.Nr. ⑱																																																																																																	
① 3~MOT	Typ ②	⑬ V~	⑭ Nm	⑦ Hz	⑧ 1/min																																																																																												
⑥ A	⑫ kW	Mo ⑨ Nm	cos φ	⑩ C86:																																																																																													
max	IP ④	I.CL. ⑤	Ta 40°C																																																																																														
			Id.Nr. ③																																																																																														
Bremse ⑯ V-	A	Nm	Geber ⑰																																																																																														
Mot.Nr. ⑱																																																																																																	
<p>MDFQA asynchronous servo motors IP23</p>  <p><b>Lenze</b> Made in Germany Hans-Lenze-Strasse 1 D-31855 Aerzen http://www.Lenze.com <b>CE</b></p> <table border="1"> <tr> <td>① 3~MOT</td> <td>Typ: ②</td> <td>Hz ⑦</td> <td></td> <td></td> <td></td> </tr> <tr> <td>I.CL. ⑤</td> <td>IP ④</td> <td>kW ⑫</td> <td></td> <td></td> <td></td> </tr> <tr> <td>Ta 40°C</td> <td></td> <td>1/min ⑧</td> <td></td> <td></td> <td></td> </tr> <tr> <td>Bremse ⑯ V</td> <td>A</td> <td>Nm ⑬</td> <td></td> <td></td> <td></td> </tr> <tr> <td>Geber ⑰</td> <td></td> <td>V ⑬</td> <td></td> <td></td> <td></td> </tr> <tr> <td>MAT-NR. ③</td> <td>AUF-NR. ⑳</td> <td>MOT-NR. ⑱</td> <td>A ⑥</td> <td>⑩</td> <td></td> </tr> <tr> <td></td> <td></td> <td></td> <td>cos φ</td> <td></td> <td></td> </tr> <tr> <td></td> <td></td> <td></td> <td>C86</td> <td></td> <td></td> </tr> </table>	① 3~MOT	Typ: ②	Hz ⑦				I.CL. ⑤	IP ④	kW ⑫				Ta 40°C		1/min ⑧				Bremse ⑯ V	A	Nm ⑬				Geber ⑰		V ⑬				MAT-NR. ③	AUF-NR. ⑳	MOT-NR. ⑱	A ⑥	⑩					cos φ						C86			<p>Three-phase modular motors MDXMA</p>  <p><b>Lenze</b> Extertal Germany <b>CE</b></p> <table border="1"> <tr> <td>① 3~MOT</td> <td>EN60034</td> <td>Hz ⑦</td> <td></td> <td></td> <td></td> </tr> <tr> <td>Typ: ②</td> <td></td> <td>kW ⑫</td> <td></td> <td></td> <td></td> </tr> <tr> <td>I.CL. ⑤</td> <td>IP ④</td> <td>1/min ⑧</td> <td></td> <td></td> <td></td> </tr> <tr> <td></td> <td></td> <td>V Δ ⑬</td> <td></td> <td></td> <td></td> </tr> <tr> <td></td> <td></td> <td>A Δ ⑥</td> <td></td> <td></td> <td></td> </tr> <tr> <td>MAT-NR. ③</td> <td></td> <td>cos φ ⑩</td> <td></td> <td></td> <td></td> </tr> <tr> <td>AUF-NR. ⑳</td> <td></td> <td>C86</td> <td></td> <td></td> <td></td> </tr> <tr> <td>MOT-NR. ⑱</td> <td></td> <td></td> <td></td> <td></td> <td></td> </tr> </table>	① 3~MOT	EN60034	Hz ⑦				Typ: ②		kW ⑫				I.CL. ⑤	IP ④	1/min ⑧						V Δ ⑬						A Δ ⑥				MAT-NR. ③		cos φ ⑩				AUF-NR. ⑳		C86				MOT-NR. ⑱					
① 3~MOT	Typ: ②	Hz ⑦																																																																																															
I.CL. ⑤	IP ④	kW ⑫																																																																																															
Ta 40°C		1/min ⑧																																																																																															
Bremse ⑯ V	A	Nm ⑬																																																																																															
Geber ⑰		V ⑬																																																																																															
MAT-NR. ③	AUF-NR. ⑳	MOT-NR. ⑱	A ⑥	⑩																																																																																													
			cos φ																																																																																														
			C86																																																																																														
① 3~MOT	EN60034	Hz ⑦																																																																																															
Typ: ②		kW ⑫																																																																																															
I.CL. ⑤	IP ④	1/min ⑧																																																																																															
		V Δ ⑬																																																																																															
		A Δ ⑥																																																																																															
MAT-NR. ③		cos φ ⑩																																																																																															
AUF-NR. ⑳		C86																																																																																															
MOT-NR. ⑱																																																																																																	

No.	Explanation	No.	Explanation
1	Motor type: Three-phase AC motor	11	Maximum current $I_{max}$ [A]
2	Lenze motor type	12	Rated power $P_N$ [kW]
3	Ident no.	13	Rated voltage $V_N$ [V]
4	Type of protection	14	Continuous standstill torque $M_0$ [Nm]
5	Thermal class	15	Temperature sensor labelling
6	Rated current $I_N$ [A]	16	Holding brake data: Voltage, current, torque
7	Rated frequency $f_N$ [Hz]	17	Encoder labelling
8	Rated speed $n_N$ [min <sup>-1</sup> ]	18	Motor No.
9	Rated torque $M_N$ [Nm]	19	Selection number for operation with servo inverters of the 9300 series <sup>1)</sup>
10	Rated power factor $\cos \varphi$	20	Production data

<sup>1)</sup> For operation with servo inverters of the 9300 series:  
Enter the indicated selection number under C0086 to automatically optimize the control characteristic.

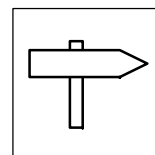

<b>1 Preface and general information</b>	<b>8</b>
1.1 About these Operating Instructions ...	8
1.1.1 Terminology used	8
1.2 Items supplied	8
1.3 Legal regulations	9
<b>2 Safety information</b>	<b>10</b>
2.1 Safety and commissioning instructions for Lenze low-voltage machinery	10
2.2 Safety and application instructions for Lenze controllers	11
2.3 Residual hazards	12
2.4 Layout of the safety information	12
<b>3 Technical data</b>	<b>13</b>
3.1 General data/application conditions	13
3.2 Ratings	13
3.3 Sound pressure level	14
<b>4 Installation</b>	<b>15</b>
4.1 Mechanical installation	15
4.1.1 Transport, storage and installation	15
4.1.2 Mounting of attachments	15
4.1.3 Assembly of motors at gearboxes with bearing flange (drive-end design N)	16
4.2 Electrical connection	18
4.2.1 Important notes	18
4.2.2 Wiring complying to EMC	20
4.2.3 Connection diagrams for servo motors MDXK / MDFQ	20
<b>5 Commissioning</b>	<b>24</b>
5.1 Before switching on	24
5.2 Operating test	25
5.3 Connection	25
5.3.1 Power connection	25
5.3.2 Resolver connection	25
<b>6 During operation</b>	<b>26</b>
<b>7 Fault detection and elimination</b>	<b>27</b>
<b>8 Maintenance/repair</b>	<b>29</b>
8.1 Maintenance intervals	29
8.2 Maintenance	29
8.2.1 Resolver adjustment of synchronous servo motors	29
8.2.2 Temperature check for servo motors	30
8.3 Repair	30

## Manufacturer's declaration / EC Declaration of Conformity '96

## Service addresses

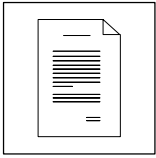

# ***Preface and general information***

## **1 Preface and general information**

### **1.1 About these Operating Instructions ...**

- These Operating Instructions are to be used for safe working on and with servo motors of type MDXK / MDFQ / MCS and modular three-phase AC motors of type MDXM. They contain safety information which must be observed.
- All persons working on or with the stated servo motors or modular three-phase AC motors must have these Operating Instructions available and observe the information and notes relevant for their work.
- The Operating Instructions must always be in a complete and perfectly readable state.
- If the information and notes given in these Operating Instructions do not meet your requirements, please refer to the Operating Instructions for the controllers.

#### **1.1.1 Terminology used**

<b>Term</b>	<b>Meaning in this document</b>
<b>motor</b>	Servo motor type MDXK, type MDFQ, type MCS Modular three-phase AC motor type MDXM
<b>Controller</b>	Any servo inverter of the 9300 series, ECS Any frequency inverter of the 8200 series
<b>Drive system</b>	Drive systems with servo motors type MDXK / MDFQ / MCS, with modular three-phase motors typ MDXM and other Lenze drive components

### **1.2 Items supplied**

The drive systems are individually combined. After receipt of the delivery, check immediately whether the items delivered match the accompanying papers. Lenze does not accept any liability for deficiencies claimed subsequently.

Claim

- visible transport damage immediately to the forwarder.
- visible deficiencies/incompleteness immediately to your Lenze representative.



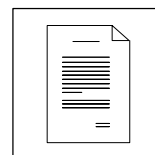

## 1.3 Legal regulations

<b>Labelling</b>	<b>Nameplate</b>	<b>CE-identification</b>	<b>Manufacturer</b>
	Lenze motors are clearly identified by the indications on the nameplate.	Conforms to the EC Low-Voltage Directive	Lenze Drive Systems GmbH Postfach 10 13 52 D-31763 Hameln
<b>Application as directed</b>	<p><b>Servo motors type MDXK / MDFQ / MCS, modular three-phase motors MDXM</b></p> <ul style="list-style-type: none"> <li>• must only be operated under the conditions prescribed in these Instructions.</li> <li>• are components: <ul style="list-style-type: none"> <li>– for the use as small drives.</li> <li>– for installation in a machine</li> <li>– used for assembly together with other components to form a machine.</li> </ul> </li> <li>• comply with the requirements of the Low-Voltage Directive.</li> <li>• are not machinery in the sense of the EC Machinery Directive.</li> <li>• are not to be used as domestic appliances, but only for industrial purposes.</li> </ul> <p><b>Drive systems with servo motors type MDXK / MDFQ / MCS, with modular three-phase motors MDXM</b></p> <ul style="list-style-type: none"> <li>• comply with the EMC Directive if they are installed according to the guidelines of CE-typical drive systems.</li> <li>• can be used: <ul style="list-style-type: none"> <li>– for operation at public and non-public mains</li> <li>– in industrial as well as residential and commercial premises.</li> </ul> </li> <li>• The user is responsible for the compliance of his application with the EC directives.</li> </ul> <p><b>Any other use shall be deemed as inappropriate!</b></p>		
<b>Liability</b>	<ul style="list-style-type: none"> <li>• The information, data, and notes in these instructions met the state of the art at the time of printing. Claims for modifications of motors which have already been supplied cannot be derived from the information, illustrations, and descriptions.</li> <li>• The specifications, processes, and circuitry described in these Operating Instructions are for guidance only and must be adapted to your own specific application. Lenze does not take responsibility for the suitability of the process and circuit proposals.</li> <li>• The specifications in these Instructions describe the product features without guaranteeing them.</li> <li>• Lenze does not accept any liability for damage and operating interference caused by: <ul style="list-style-type: none"> <li>– Disregarding the operating instructions</li> <li>– unauthorized changes or modifications at the motors.</li> <li>– operating errors</li> <li>– improper working on and with the motors.</li> </ul> </li> </ul>		
<b>Warranty</b>	<ul style="list-style-type: none"> <li>• Warranty conditions: see Sales and Delivery Conditions of Lenze Drive Systems GmbH</li> <li>• Warranty claims must be made to Lenze immediately after detecting the deficiency or fault.</li> <li>• The warranty is void in all cases where liability claims cannot be made.</li> </ul>		
<b>Waste disposal</b>	<b>Material</b>	<b>recycle</b>	<b>dispose</b>
	Metal	•	-
	Plastic	•	-
	Printed-board assemblies	-	•



## Safety information

## 2 Safety information

### 2.1 Safety and commissioning instructions for Lenze low-voltage machinery

(according to Low-Voltage Directive 73/23/EWG)

#### 1. General

Low-voltage machines have dangerous, live and rotating parts as well as possibly hot surfaces. All operations serving transport, connection, commissioning and maintenance are to be carried out by skilled, responsible technical personnel (observe EN 50110-1 (VDE 0105-100); IEC 60364). Improper handling can cause severe injuries or damages. Synchronous machines induce voltages at open terminals during operation.

#### 2. Application as directed

These low-voltage machines are intended for industrial and commercial installations. They comply with the harmonized standards of the series EN 60034 (VDE 0530). Their use in hazardous areas is prohibited unless they are expressly intended for such use (follow additional instructions).

IP23 ≤ enclosures are by no means intended for outdoor use.

Air-cooled designs are rated for ambient temperatures between -15°C or -10°C and +40°C and altitudes of ≤ 1000 m a.m.s.l., from -20 °C to +40 °C without brake or with spring-operated brake, with separate ventilation or self ventilation, from -15 °C to +40 °C with permanent magnet brake and from -10 °C to +40 °C with separate fan. Check indications on the nameplate and if they are different, observe them. The conditions on site must correspond to all nameplate data.

Low-voltage machines are components for the installation into machines as defined in the Machinery Directive 98/37/EC.

Commissioning is prohibited until the conformity of the end product with this Directive has been established (follow a.o. EN 60204-1).

The integrated brakes cannot be used as safety brakes. It cannot be guaranteed that factors, which cannot be influenced, such as oil ingress because of a defective A-side shaft seal, cause a torque reduction.

#### 3. Transport, storage

The forwarder must be informed directly after receipt of the goods about all damages or deficiencies; if necessary, commissioning must be stopped. Tighten screwed-in ring bolts before transport. They are designed for the weight of the low-voltage machine, do not apply extra loads. If necessary, use suitable and adequately dimensioned means of transport (e.g. rope guides).

Remove the shipping brace before commissioning. Reuse it for further transports. For storage of low-voltage machines ensure a dry, dust free and low vibration ( $v_{rms} \leq 0.2 \text{ mm/s}$ ) environment (damage while being stored). Measure the insulation resistance before commissioning. For values  $\leq 1 \text{ kW}$  per volt of rated voltage, dry the winding.

#### 4. Installation

Ensure an even surface, solid foot or flange mounting and exact alignment if a direct clutch is connected. Avoid resonances with the rotational frequency and double mains frequency which may be caused during assembly. Turn rotor by hand, listen for unusual grinding noises. Check the direction of rotation when the clutch is not active (observe section 5).

Use appropriate tools to mount or remove belt pulleys and clutches (heat generation!) and cover them with a touch guard. Impermissible belt tensions must be avoided (technical list).

The machines are half-key balanced. The clutch must be half-key balanced, too. The visible outstanding part of the key must be removed.

If required, provide pipe connections. Mounting positions with shaft end at top must be protected with a cover which avoids the ingress of foreign particles into the fan. Free circulation of the cooling air must be ensured. The exhaust air - also the exhaust air of other machines next to the drive system - must not be intaken again immediately.

#### 5. Electrical connection

All operations must only be carried out by qualified and skilled personnel when the low-voltage machine is in standstill and when the machine is de-energized and protected against unintentional restart. This also applies to auxiliary circuits (e.g. brake, encoder, separate fan).

Check safe isolation from the supply!

If the tolerances in EN 60034-1; IEC 34 (VDE 0530-1) - voltage  $\pm 5\%$ , frequency  $\pm 2\%$ , wave form, symmetry - are exceeded, more heat will be generated and the electromagnetic compatibility will be influenced. Observe the indications on the nameplate, operating notes, and the connection diagram in the terminal box.

The connection must ensure a continuous and safe electrical supply (no loose wire ends); use appropriate cable terminals. The connection to the PE conductor must be safe. The plug-in connector must be bolted tightly (to stop).

The minimum clearances between bare, live parts and earth must not fall below: 8 mm at  $U_N \leq 550 \text{ V}$ , 10 mm at  $V_N \leq 725 \text{ V}$ , 14 mm at  $V_N \leq 1000 \text{ V}$ .

The terminal box must be clean and dry; foreign particles, dirt and moisture disturb operation. All unused cable entries and the box itself must be sealed against dust and water. For the trial run without output elements, lock the key. Check brake operation before commissioning of low-voltage machines with brakes.

#### 6. Operation

Vibration severities  $v_{rms} \leq 3.5 \text{ mm/s}$  ( $P_N \leq 15 \text{ kW}$ ) or  $4.5 \text{ mm/s}$  ( $P_N > 15 \text{ kW}$ ) are acceptable when the clutch is activated. If deviations from normal operation occur, e.g. increased temperatures, noises, vibrations, find the cause and, if necessary, contact the manufacturer. Switch-off the machine in problematic situations.

If the drive is exposed to dirt, clean it regularly.

Do not switch-off the protection devices, not even for trial runs. Integrated temperature sensors do not provide full protection. If necessary, limit the maximum current. Connect the function blocks such that the machine switches off after several seconds of operation at  $I > I_N$ , especially on risk of blocking.

Shaft seals and bearings have a limited service life.

Regrease the bearings using the relubrication facility while the low-voltage machine is running. Observe the saponification number. If the grease drain hole is sealed with a plug (IP54 drive end; IP23 drive end and non-drive end), remove the plug before commissioning. Seal the bore holes with grease. If the bearing is lubricated for life (ZZ bearing), replace it after approx. 10.000 h - 20.000 h, the latest however after 3 - 4 years. Observe the manufacturer's instructions.



## 2.2 Safety and application instructions for Lenze controllers

(to: Low-Voltage Directive 73/23/EEC)

### 1. General

During operation, drive controllers may have live, bare, in some cases also movable or rotating parts, as well as hot surfaces, depending on their type of protection.

Non-authorized removal of the required cover, inappropriate use, incorrect installation or operation, creates the risk of severe injury to persons or damage to material assets.

Further information can be obtained from the documentation.

All operations concerning transport, installation, and commissioning as well as maintenance must be carried out by qualified, skilled personnel (IEC 60364 or CENELEC HD 384 or VDE 0100 and IEC report 664 or VDE 0110 and national regulations for the prevention of accidents must be observed).

According to this basic safety information qualified skilled personnel are persons who are familiar with the installation, assembly, commissioning, and operation of the product and who have the qualifications necessary for their occupation.

### 2. Application as directed

Drive controllers are components which are designed for installation in electrical systems or machinery.

When installing the unit into machines, commissioning of the controller (i.e. operation as directed) is prohibited until it is proven that the machine corresponds to the regulations of the EC Directive 98/37/EC (Machinery Directive); EN 60204 (VDE 0113).

Commissioning (i.e. starting of operation as directed) is only allowed when there is compliance with the EMC Directive (89/336/EEG).

The controllers meet the requirements of the Low-Voltage Directive 73/23/EEC. The harmonized standards EN 50178 (VDE 0160) / EN 60439-1 (VDE 0660-500) and EN 60146 (VDE 0558) are applicable to the controllers.

The technical data and information on the connection conditions must be obtained from the nameplate and the documentation and must be observed in all cases.

### 3. Transport, storage

Notes on transport, storage and appropriate handling must be observed.

The climatic conditions must be maintained as prescribed in EN 50178 (VDE 0160).

### 4. Installation

The units must be installed and cooled according to the regulations given in the corresponding documentation.

The controllers must be protected from inappropriate loads. Particularly during transport and handling, components must not be bent and/or insulation distances must not be changed. Avoid touching of electronic components and contacts.

Controllers contain electrostatically sensitive components, which can easily be damaged by inappropriate handling. Electrical components may not be damaged or destroyed mechanically (health risks are possible!).

### 5. Electrical connection

When working on live controllers, the valid national regulations for the prevention of accidents (e.g. VBG 4) must be observed.

Carry out the electrical installation in compliance with the corresponding regulations (e.g. cable cross-sections, fuses, PE connection). More detailed information is given in the corresponding documentation and must be observed.

Notes about wiring according to EMC regulations, such as shielding, grounding, filters and cable routing, are included in the documentation for the controllers. These notes also apply to CE-marked controllers.

The compliance with limit values required by the EMC legislation is the responsibility of the manufacturer of the machine or system.

### 6. Operation

If necessary, systems including controllers must be equipped with additional monitoring and protection units according to the applicable safety regulations, e.g. low on technical tools, regulations for the prevention of accidents, etc. Modifications on the controllers by means of the operating software are allowed.

After disconnection of the controllers from the supply voltage, live parts of the controller and power connections may not be touched immediately, because of possibly charged capacitors. For this observe the corresponding notes on the controller.

During operation all covers and doors must be closed.

### 7. Maintenance and service

Observe the manufacturer's documentation.

**This safety information must be kept!**

**The product-specific safety and application notes in these Operating Instructions must also be observed!**



## Safety information

### 2.3 Residual hazards

<b>Protection of persons</b>	<p>The motor surfaces can be very hot. Danger of burning when touching!</p> <ul style="list-style-type: none"> <li>• If necessary, provide protection against contact.</li> </ul> <p>If the motor is inverter driven, high frequency voltages may be capacitively transferred to the motor housing.</p> <ul style="list-style-type: none"> <li>• Ensure careful earthing of the motor housing.</li> </ul> <p>Danger of unintended starts or electric shocks.</p> <ul style="list-style-type: none"> <li>• Connections must only be made when no voltage is applied and the motor is in standstill.</li> <li>• Integrated brakes cannot be used as safety brakes.</li> </ul>
<b>Controller protection</b>	<p>Integrated temperature sensors <b>do not provide full protection</b> for the machine.</p> <ul style="list-style-type: none"> <li>• Limit maximum current if necessary, connect the function blocks such that the machine switches off after several seconds of operation at <math>I &gt; I_N</math>, especially on risk of blocking.</li> <li>• Integrated overload protection does not prevent overload under all circumstances.</li> </ul> <p>Integrated brakes are <b>no fail-safe brakes</b>.</p> <ul style="list-style-type: none"> <li>• Torque reduction is possible.</li> </ul> <p>Fuses do not protect the motor.</p> <ul style="list-style-type: none"> <li>• Use current-dependent motor protection switches for an average switching frequency.</li> <li>• Use integrated temperature switches for a high switching frequency.</li> </ul> <p>Excessive torques may result in demagnetization or break of the motor shaft.</p> <ul style="list-style-type: none"> <li>• Do not exceed the max. torques indicated in the catalog.</li> </ul> <p>Shear forces from the motor shaft are possible.</p> <ul style="list-style-type: none"> <li>• Exact alignment of motor shaft and shaft of driving machine required.</li> </ul>
<b>Protection against fire</b>	<p>Protection against fire</p> <ul style="list-style-type: none"> <li>• Avoid contact with inflammable material or substances.</li> </ul>

### 2.4 Layout of the safety information





All safety information given in these Operating Instructions has the same layout:

The icon characterizes the type of danger



**Signal word!** (characterizes the severity of danger)

Note (describes the danger and gives information how to prevent dangerous situations)

Icon	Signal word		Consequences when disregarding safety information
	Signal word	Meaning	
 hazardous electrical voltage   general danger	<b>Danger!</b>	<b>Impeding danger for persons</b>	Death or most serious injuries
	<b>Warning!</b>	<b>Possible, very dangerous situation for persons</b>	Death or most serious injuries
	<b>Caution!</b>	<b>Possible, dangerous situation for persons</b>	Minor injuries
	<b>Stop!</b>	<b>Possible damage to material assets</b>	Damage of the drive system or its surroundings
	<b>Note!</b>	<b>Useful note or tip</b> If you observe it, handling of the drive system will be made easier.	

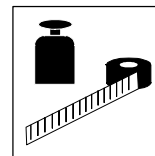

## 3 Technical data

### 3.1 General data/application conditions

Field	Values	
<b>Mounting positions</b>	Applicable in all mounting positions	Vertical mounting positions to DIN-IEC 34 part 7 are possible, if they correspond to the designs.
<b>Type of protection</b>	See nameplate	Types of protection are valid only for horizontal installation.
<b>Thermal class</b>	F (155 °C) to DIN-IEC 34 / VDE 0530	If the limit temperature is exceeded, the insulation will be damaged or destroyed.
<b>Tropical insulation</b>	Cannot be granted	
<b>Permissible temperature range</b>	Designs	
	<ul style="list-style-type: none"> <li>Non-ventilated or with self-ventilation, without brake or with spring-operated brake</li> </ul>	-20 °C ... +40 °C Without power derating
	<ul style="list-style-type: none"> <li>With permanent magnet brake</li> </ul>	-10 °C ... +40 °C Without power derating
	<ul style="list-style-type: none"> <li>With separate fan, without permanent magnet brake</li> </ul>	-15 °C ... +40 °C Without power derating
<b>Permissible installation height h</b>	h ≤ 1000 m a.m.s.l. 1000 m a.m.s.l. < h ≤ 5000 m a.m.s.l.	Without power derating With power derating
<b>Approvals</b>	CE Low-Voltage Directive	
<b>Permissible voltage</b>	1.5 kV peak value	5 kV/μs voltage rise *)

\*) See catalog.

### 3.2 Ratings

Ratings	Values	Note
<b>Motor, separate fan</b>	See the corresponding nameplate. Further data can be obtained from the catalog.	The indicated values apply to the following: <ul style="list-style-type: none"> <li>For servo motors MDXK, MDFQ, MCS for operation with Lenze 9300 servo inverters when operated at a 400 V mains and an inverter chopping frequency of 8 or 16 kHz.</li> <li>MDXM modular three-phase AC motors; for operation at the mains or together with Lenze frequency inverters from 4 to 16 kHz.</li> </ul>
<b>Maximum motor speed [min<sup>-1</sup>] (mechanical limit)</b>	<ul style="list-style-type: none"> <li>Synchronous servo motors MCS: 4000 ... 8000</li> <li>MDXKS synchronous servo motors: 5000 ... 8000</li> <li>MDXKA asynchronous servo motors: 8000</li> <li>MDFQA asynchronous servo motors: 4500 ... 5000</li> <li>Modular three-phase AC motors: 4500</li> </ul>	
<b>Weights</b>	See catalog.	The indicated values are for guidance and help with the selection.
<b>Torques</b>	See catalog.	<ul style="list-style-type: none"> <li>If the torques are too high, the motor shaft may break or be demagnetized.</li> <li>Max. torques indicated in the catalog must be observed.</li> <li>Corresponding torques can be achieved by appropriate motor/controller combinations.</li> </ul>
<b>Axial forces</b>	See catalog.	If the forces are too high, the bearing life will be shortened.
<b>Radial forces</b>	See catalog.	<ul style="list-style-type: none"> <li>Observe the permissible forces indicated in the catalog.</li> </ul>

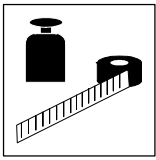

## Technical data



### Note!

You can also operate asynchronous servo motors MDXKA / MDFQA / MCS and MDXMA modular three-phase motors with other inverters. Please observe the minimum clock frequency indicated in the table. Depending on the modulation and control characteristic of the inverter, the temperature monitoring of the motor might be activated. If so, reduce the power.

Motor type	Minimum inverter clock frequency [kHz]
MDXKA 056 ... 080	4
MDXKA 090 ... 112	8
MDFQA	8
MDXMA	4

## 3.3 Sound pressure level

Motor type	Fan operation	Sound pressure level [db (A)]	Notes
MDSKA 056		60	Sound pressure level, A-evaluated Distance = 1 m Idling motor, U = 3400 min <sup>-1</sup>  Operation with 9300 servo inverter or 8200 frequency inverter Inverter clock frequency: 8 or 16 kHz
MDSKA 071		60	
MDFKA 071	x	62	
MDSKA 080		62	
MDFKA 080	x	64	
MDSKA 090		63	
MDFKA 090	x	66	
MDSKA 100		69	
MDFKA 100	x	72	
MDSKA 112		72	
MDFKA 112	x	75	
MDFQA 110	x	81	
MDFQA 112	x	84	
MDFQA 132	x	87	
MDFMA	x	≤ 70	



### Note!

The noise generation of motor with separate fan can be reduced if they are connected to 9300- servos:

- If the application does not require ventilation through a separate fan over the whole operating time (e.g. intermittent operation with long cooling periods), the separate fan should only be connected if the winding temperature exceeds a certain limit.
- Our recommendation: from 120 °C on

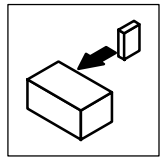

## 4 Installation

### 4.1 Mechanical installation

#### 4.1.1 Transport, storage and installation

<b>Transport</b>	<ul style="list-style-type: none"> <li>● Use appropriate means of transport or hoists.             <ul style="list-style-type: none"> <li>– Ensure safe mounting and fixing: Some motors are equipped with eyelets for safe fixing at hoists. They are used for the secure attachment to hoists. They are designed <b>only</b> for the motor weight and must <b>not</b> be used for the assembly of other components to the motor, (for weights see catalog).</li> </ul> </li> <li>● Ensure vibration-free transport of motors.</li> <li>● Avoid heavy shocks.</li> </ul>
<b>Storage location</b>	<ul style="list-style-type: none"> <li>● Free of vibrations             <ul style="list-style-type: none"> <li>– If vibrations cannot be avoided the rotor must be rotated in the bearings once a week.</li> </ul> </li> <li>● Dry in an atmosphere free aggressive particles or gases.</li> <li>● Dust-free</li> <li>● Without sudden temperature changes</li> <li>● All steel parts are corrosion protected when being delivered. Do not remove the protection! Check it every three month and renew it if necessary.</li> </ul>
<b>Installation</b>	<ul style="list-style-type: none"> <li>● Provide fixings which correspond to the mounting position, weight and torque of the motor.</li> <li>● The foot and flange surfaces of the motor must be fitted evenly before the motor is fastened.             <ul style="list-style-type: none"> <li>– Incorrect motor alignment shortens the service life of bearings and transmission elements.</li> </ul> </li> <li>● Clutches and other transmission elements must be attached according to instructions.             <ul style="list-style-type: none"> <li>– Shocks on the shafts can cause bearing damage, see chapter. 4.1.2</li> </ul> </li> <li>● Do not exceed the ambient temperature permissible during operation (see chapter 3.1).</li> <li>● Humidity <math>\leq 85\%</math>, without condensation</li> <li>● Vibration <math>\leq 2g</math> without resonances</li> <li>● Fix motor securely</li> <li>● Ensure unimpeded ventilation</li> <li>● Hot surfaces during operation, up to 140°C! Provide touch guards!</li> </ul>

#### 4.1.2 Mounting of attachments

Follow these Instructions! Observe that the warranty and liability only apply to approved installations, fittings and retrofittings.

- If necessary, remove the corrosion protection from the shaft ends and flanges of new motors. Take special care that the solvents do not damage the bearing!
- The mounting dimensions are standard dimensions according to IEC 34.
- Attach transmission elements:
  - Avoid shocks! This may destroy the motor.
  - Use the center bore in the motor shaft (to DIN 332, design D) to attach the transmission elements.
  - Tolerances of the shaft ends  
 $\leq \varnothing 50$  mm: ISO k6,  $> \varnothing 50$  mm: ISO m6.
- Disassemble with a pull-off device only.
- For the use of belts for torque/power transmission:
  - Check belt tension
  - Do not exceed permissible radial load of the motor shaft, see specifications in the catalog.

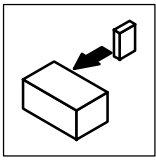

## Installation

### 4.1.3 Assembly of motors at gearboxes with bearing flange (drive-end design N)



#### Stop!

- In the event of load shocks or sudden load changes use coupling hub with clamping hub or clamp ring hub.
- if necessary, replace motor key with a shorter key (see Tab. 1).

1. Bolt coupling hub with dimension "m" acc. to Tab. 1, no impacts on the motor shaft!
2. Connect motor and gearbox with a spider.
3. Bolt motor.



Abb. 1 Drive-end design N



Drive size	Motor shaft		Dimension	Standard hub Fixing screw Thread [mm]	Clamping hub		Key <sup>1)</sup>	Clamping ring hub		Servo motor		Three-phase AC motor
	d [mm]	max. l [mm]			Thread [mm]	Tightening tor- que [ Nm ]		Thread [mm]	Tightening tor- que [Nm]	MDXK	MDFQ	
1A	11	23	23	M4	M3	1.34	DIN 6885/1 [mm]	M3	1.34	MDSKS 036		MDXMA 063
1B	14	30	30	M4	M3	1.34	*	M3	1.34	MDSKX 056		MDXMA 071
2B	11	23	23	M4	M3	1.34		M3	1.34	MDSKS 036		MDXMA 063
1C	19	40	25	M5	M6	10.5	B 6 x 6 x 16	M4	2.9	MDXKX 071		MDXMA 080
2C	14	40	25	M5	M6	10.5	B 5 x 5 x 16	M4	2.9	MDSKX 056		MDXMA 071
3C	14	40	25	M5	M6	10.5		M4	2.9	MDSKX 056		MDXMA 071
4C	14	40	25	M5	M6	10.5		M4	2.9	MDSKX 056		MDXMA 071
1D	24	50	50	M5	M4	2.9	*	M4	-	MDXKA 080 MDXKA 090		MDXMA 090
2D	19	40-50	50	M5	M6	10.5		M4	2.9	MDXKX 071		MDXMA 071
1E	28	30-60	30	M5	M6	10.5	B 8 x 7 x 18	M5	6	MDXKA 100		MDXMA 100 MDXMA 112
2E	24	30-60	30	M5	M6	10.5		M5	6	MDXKA 080 MDXKA 090		MDXMA 090
3E	19	30-60	30	M5	M6	10.5	B 6 x 6 x 18	M5	6	MDXKX 071		MDXMA 080
1F	28	30-60	30	M5	M6	10.5	B 8 x 7 x 18	M5	6	MDXKA 100		MDXMA 100 MDXMA 112
2F	24	30-60	30	M5	M6	10.5		M5	6	MDXKA 080 MDXKA 090		MDXMA 090
1G	38	80	80	M6	M8	25	*	M5	6	MDXKA 112	MDFQA 100 MDFQA 112	MDXMA 132
2G	28	60	60	M6	M8	25		M5	6	MDXKA 100		
3G	38	80	80	M6	M8	25		M5	6	MDXKA 100		
1H	42	110	110	M8	M10	69	*	M10	-			MDXMA 160
2H	48	110	110	M8	M10	69		M10	-			MDXMA 180
3H	38	80	80	M8	M10	69		M8	35	MDXKA 112	MDFQA 100 MDFQA 112	MDXMA 132
1K	55	110	110	M8	M10	69	*	M10	-		MDFQA 132	MDXMA 200
2K	60	140	140	M8	M10	69		M10	-			MDXMA 225

Tab. 1 Assembly of motors at gearboxes with bearing flange

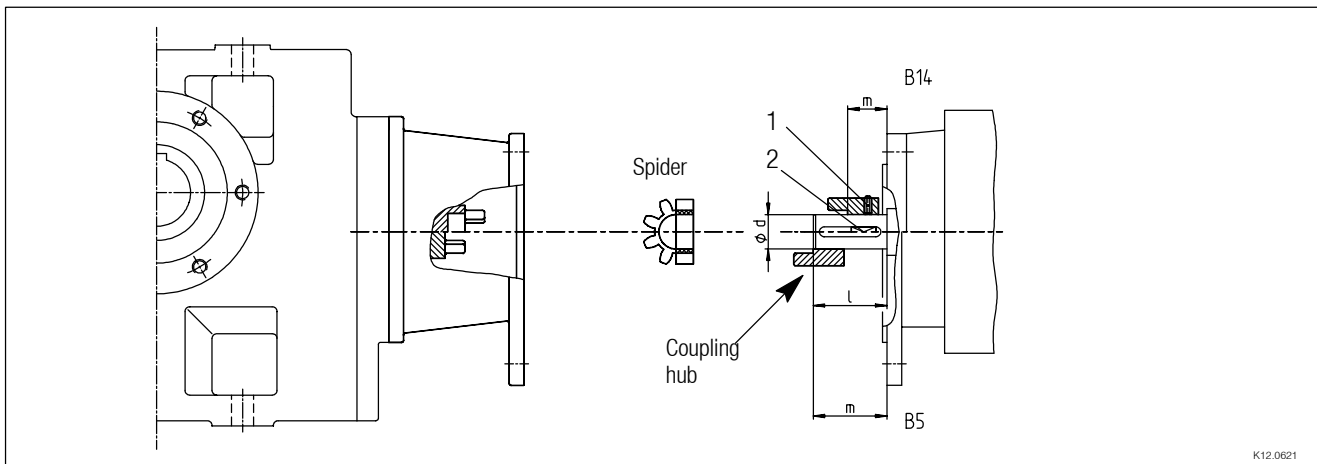
\* Use genuine motor key

<sup>1)</sup> Key for standard hub and clamping hub

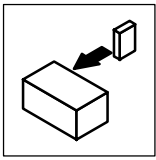

# Installation

## 4.2 Electrical connection

### 4.2.1 Important notes



#### Danger!

Hazardous voltage at power connections, posing danger to life even if the connector is withdrawn: Residual voltage > 60V!

It is absolutely vital to disconnect the controller from and to wait until the motor has come to a standstill before working on the power connections (voltage at contacts while motor is rotating).

<b>General</b>		<ul style="list-style-type: none"> <li>• Observe the notes in the terminal box of the motor.</li> <li>• Ensure correct layout of the terminal bridges.</li> <li>• Screw connections must be tightened.</li> <li>• Connect the PE conductor to the grounding screw.</li> <li>• Use a strain relief for the connection cable.</li> <li>• Earth the motor carefully.</li> </ul>
<b>Voltage supply</b>	Servo motors	<ul style="list-style-type: none"> <li>• Servo motors must be supplied by inverters.</li> <li>• Connect the encoders mounted to the motor with the corresponding connections of the inverter.</li> </ul>
	Separate fan (optionally)	<ul style="list-style-type: none"> <li>• AC voltage supply to nameplate of the fan</li> </ul>
	Holding brake (optionally)	<ul style="list-style-type: none"> <li>• DC voltage supply to nameplate of the brake or supply with AC voltage through a preconnected rectifier.</li> <li>• With bridge rectifiers brakes for 205 V can be supplied from the 230 V mains, brakes for 103 V can be supplied from the 115 V mains.</li> <li>• Do not supply brakes from the AC main using half-wave rectifiers</li> </ul>
<b>Inverter operation</b>		<ul style="list-style-type: none"> <li>• Observe the connection information given in the corresponding Operating Instructions.</li> <li>• Ensure that motor and inverter are assigned correctly.</li> <li>• Take special care for speed limits and winding load capacities. *</li> </ul>
<b>Cable cross-sections</b>		<ul style="list-style-type: none"> <li>• The connection cables must be selected carefully to avoid overheating.</li> <li>• Adhere to minimum cross-sections acc. to DIN 57100 and protect accordingly (see Tab. 1).</li> </ul>
<b>Motor protection</b>	Protection against overload	<ul style="list-style-type: none"> <li>• Established current-dependent starting circuit breakers for average switching.               <ul style="list-style-type: none"> <li>– Setting of the rated current indicated on the nameplate.</li> </ul> </li> <li>• For very high switching rates: Use Lenze three-phase AC motors equipped with thermistors or temperature sensors in the winding.               <ul style="list-style-type: none"> <li>– The thermistors are available as normally-open or normally-closed contacts for the winding. The activation temperature is freely adjustable.</li> </ul> </li> </ul>
	Motor cables	<ul style="list-style-type: none"> <li>• No protection possible because of temperature sensor or PTC thermistor in winding               <ul style="list-style-type: none"> <li>– Take measures according to DIN 57100 / VDE 053.</li> </ul> </li> </ul>
	Inverter operation	<ul style="list-style-type: none"> <li>• Because of the current and voltage conversion the output current can be much higher than the input current.               <ul style="list-style-type: none"> <li>– The motor cable cannot be protected via the mains input fuses of the inverter. Take measures according to DIN 57100 / VDE 053.</li> </ul> </li> </ul>

\* Voltage limits: 1.5 kV peak value, 5 kV/μs voltage rise; for further information see the catalog.

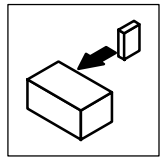

Current load capacity of insulated cables of protection devices <sup>1)</sup> (DIN 57100 / VDE 0100 T 523)												
Rated cross-section q [mm <sup>2</sup> ]	group 1 <sup>2)</sup>				group 2 <sup>3)</sup>				group 3 <sup>4)</sup>			
	Cable I <sub>N</sub> [A]		Protection device <sup>5)</sup> I <sub>N</sub> [A]		Cable I <sub>N</sub> [A]		Protection device <sup>5)</sup> I <sub>N</sub> [A]		Cable I <sub>N</sub> [A]		Protection device <sup>5)</sup> I <sub>N</sub> [A]	
	Cu	Al	Cu	Al	Cu	Al	Cu	Al	Cu	Al	Cu	Al
0.75	–	–	–	–	12	–	6	–	15	–	10	–
1.0	11	–	6	–	15	–	10	–	19	–	10	–
1.5	15	–	10	–	18	–	10	–	24	–	20	–
20	20	15	16	10	26	20	20	16	32	26	25	20
25	25	20	20	16	34	27	25	20	42	33	35	25
33	33	26	25	20	44	35	35	25	54	42	50	35
45	45	36	35	25	61	48	50	35	73	57	63	50
61	61	48	50	35	82	64	63	50	98	77	80	63
83	83	65	63	50	108	85	80	63	129	103	100	80
35	103	81	80	63	135	105	100	80	158	124	125	100
50	132	103	100	80	168	132	125	100	198	155	160	125
70	165	–	125	–	207	163	160	125	245	193	200	160
95	197	–	160	–	250	197	200	160	292	230	250	200
120	235	–	200	–	292	230	250	200	344	268	315	200
150	–	–	–	–	335	263	250	200	391	310	315	250

Maximum ambient temperature: 30 °C

- 1) With adjustable protection devices (starting circuit breakers, power switches). Set device to rated conductor current. Line protection switch to DIN 57641 / VDE 0641 / CEE 19 and line protection fuses to DIN 57636 / VDE 0636 (see table).
- 2) One or several single-core cable routed in pipes.
- 3) Multi-core cables, e.g. light plastic-sheathed cables, hard-metal-sheathed cables, lead-sheathed cables, flat webbed cables, flexible cables.
- 4) Single-core cables routed in the air with a space of at least its diameter in between.
- 5) With adjustable protection devices (starting circuit breaker, power switches) set the device to rated conductor current. Line protection switch to DIN 57641 / VDE 0641 / CEE 19 and line protection fuses to DIN 57636 / VDE 0636 (see table).

Cable connectors and connection studs			
Motor type	Power connection		Encoder/fan connection
	Cable connectors	Connection stud/connection terminal	Cable connectors
MDSK 056	1 x M20 x 1,5 + 1 x M16 x 1,5	0.08 ... 2.5 mm <sup>2</sup>	1 x M20 x 1.5 + 1 x M16 x 1.5
MDXK 071		0.08 ... 2.5 mm <sup>2</sup>	
MDXK 080		0.08 ... 2.5 mm <sup>2</sup>	
MDSK 090		0.08 ... 2.5 mm <sup>2</sup>	
MDXK 100		0.2 ... 10 mm <sup>2</sup>	
MDXK 112	1 x M32 x 1.5 + 1 x M25 x 1.5	0.2 ... 10 mm <sup>2</sup>	
Power connection			Fan connection
MDFQ 100	1 x M40 x 1.5 + 1 x M20 x 1.5 + 1 x M16 x 1.5	M6	1 x M16 x 1.5
MDFQ 112	1 x M50 x 1.5 + 1 x M20 x 1.5 + 1 x M16 x 1.5	M8	
MDFQ 132	1 x M63 x 1.5 + 1 x M50 x 1.5 + 2 x M16 x 1.5	M12	

\* For connection of parallel screened cables, e.g. 3 St 4 x 35 mm<sup>2</sup> or 4 St 4 x 25 mm<sup>2</sup>



## Stop!

The terminal box bores have plugs as transport protections. To achieve the enclosure type they must be replaced with cable connectors or blanking plugs.

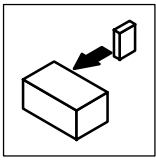

# Installation

## 4.2.2 Wiring complying to EMC

The wiring according to EMC is described in detail in the Operating Instructions for the Lenze 9300 servos and the Lenze 8200 frequency inverters.

- Use of EMC metal cable connectors with screen contact.
- Screen contact at motor and device.

## 4.2.3 Connection diagrams for servo motors MDXK / MDFQ



### Stop!

- Tighten the union nut of the plug-in connectors.
- Secure O-ring for vibration impact.
  - Power connection MDXK 036...090, MCS 06...14: O-ring 18 x 1.5 mm
  - Power connection MDXK 100...112: O-ring 27 x 4 mm
  - Encoder connection, fan connection: O-ring 18 x 1.5 mm
- Never withdraw the connector while live as it may otherwise be destroyed!  
Inhibit the controller before withdrawing the connector!

## Power connection servo motors MDXK 036 ... 090, MDXK 100 ... 112, MCS 06...19

Plug-in connector			MDXK 036 ... 090, MCS 06...19	MDXK 100 ... 112
Pin no.	Terminal designation	Meaning		
1	Y1 / BD1	Holding brake +		
2	Y2 / BD2	Holding brake -		
PI	PI	PE conductor		
4	U	Power phase U		
5	V	Power phase V		
6	W	Power phase Strang W		
<b>Connection diagram of angle box INTERCONNECTRON size 1.5 / motor connection + brake</b>				
			MCS 14...19, MDXK 100 ... 112	
Pin no.	Terminal designation	Meaning		
+	Y1 / BD1	Holding brake +		
-	Y2 / BD2	Holding brake -		
PI	PI	PE conductor		
U	U	Power phase U		
V	V	Power phase V		
W	W	Power phase W		

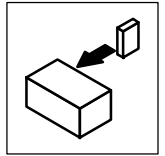

Terminal box			MDXK 036 ... 090	MDXK 100 ... 112
Terminal	Name	Meaning		
U	U1	Motor winding phase U		
V	V1	Motor winding phase V		
W	W1	Motor winding phase W		
Y1 / BD1	+	Holding brake		
Y2 / BD2	-			
S1		Thermal switch		
S2				
T1	+ KTY	Temperature sensor +		
T2	- KTY	Temperature sensor -		
P1	PTC	PTC		
P2	PTC			

## Power connection for MDFQA 100, MDFQA 112/132 servo motors MDXM three-phase motors

Terminal box			MDFQA 100	MDFQA 112/132, MDXM
Terminal	Name	Meaning		<p>Star connection</p>
L1	U1	Motor winding phase U		
L2	V1	Motor winding phase V		<p>Delta connection</p>
L3	W1	Motor winding phase W		
PI		PE conductor - motor housing		
S1		Thermal switch		
S2				
T1	+ KTY	Temperature sensor +		
T2	- KTY	Temperature sensor -		

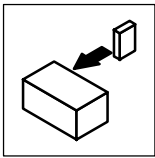

# Installation

## Fan connection

Plug-in connector		
Pin no.	Terminal designation	Meaning
1		not assigned
2	PI	PE conductor
3		not assigned
4		not assigned
A	L1	Winding - fan
B	N	
C		not assigned
D		

K33.0018/4

## Resolver connection

Plug-in connector		
Pin no.	Terminal designation	Meaning
1	+ Ref	Transformer windings (Reference windings)
2	- Ref	
3		not assigned
4	+ Cos	Stator windings - cosine
5	- Cos	
6	+ Sin	Stator winding - sine
7	- Sin	
8		not assigned
9		
10		
11	+ KTY	Temperature sensor + Temperature sensor -
12	- KTY	

K33.0018/3

Terminal box		
Terminal	Name	Meaning
T1	+ KTY	Temperature sensor + Temperature sensor -
T2	- KTY	
S1		Thermal switch
S2		
B1	+ Ref	Resolver
B2	- Ref	
B3		not assigned
B4	+ cos	Resolver
B5	- cos	
B6	+ sin	
B7	- sin	
B8		not assigned
U1	L1	Separate fan
U2	N	
Y2*	-	Holding brake
Y1*	+	

\* When using the version "with integrated rectifier", the voltage supply for the brake is directly applied to the rectifier. With this variant, the terminals Y1 and Y2 are not provided on the terminal strip.

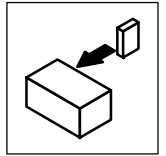

## Connection of incremental encoder / sin-cos absolute value encoder

Plug-in connector		
Pin no.	Terminal designation	Meaning
1	B	Track B / + SIN
2	$\bar{A}$	Track A inverse / - COS
3	A	Track A / + COS
4	+ 5 V	Supply + 5 V / + 8 V
5	GND	Mass
6	$\bar{Z}$	Zero track inverse / - RS485
7	Z	Zero track / + RS485
8		not assigned
9	$\bar{B}$	Track B inverse / - SIN
10		not assigned
11	+ KTY	Temperature sensor +
12	- KTY	Temperature sensor -

Terminal box		
Terminal	Name	Meaning
T1	+ KTY	Temperature sensor +
T2	- KTY	Temperature sensor -
B1	+ UB	Incremental encoder supply +
B2	$\pm 0V$	Incremental encoder supply -
B3	A	Incremental encoder track A
B4	- A	Incremental encoder track A inverse
B5	B	Incremental encoder track B
B6	- B	Incremental encoder track B inverse
B7	N	Incremental encoder track C (zero track)
B8	- N	Incremental encoder track C (zero track inverse)
B10	Screen	Incremental encoder screen
U1	L1+	Separate fan
U2	N	

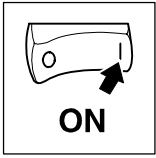

## Commissioning

### 5 Commissioning

- Commission the drive system according to the Operating Instructions for the controller.
- Reduce the max. current for commissioning, e.g. to rated machine current.



#### Stop!

Integrated overload protection does not prevent overload under all circumstances!  
Limit maximum current to necessary value!  
Connect the function blocks such that the machine switches off after several seconds of operation with  
 $I > I_N$ , especially on risk of blocking.

#### 5.1 Before switching on

Check the following before commissioning for the first time, commissioning after a longer standstill, maintenance or repair of the motor:

- Are the screw connections of all mechanical and electrical elements fastened tightly?
- Is the ventilation of the cooling air unimpeded and free?
- Is the overheating protection (temperature monitoring evaluation) o.k.?
- Is the direction of rotation of the separate fan correct?
- Does the parameter setting of the controller match the motor?  
(see Operating Instructions of controller)



#### Note!

If the application requires extremely high control accuracy, the phase error of the resolver can be compensated:

- Use the resolver data indicated on the nameplate for parameter setting of the controller.
- Are the electrical connections o.k.?
- Is the motor connection in phase?
- For gearboxes with ventilation: Ensure ventilation!
- Is the motor protected against contact with rotating elements or hot surfaces?



#### Danger!

Integrated brakes are no fail-safe brakes!



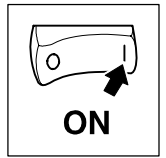

## 5.2 Operating test

- Check all functions of the drive after commissioning:
  - Direction of rotation of the motor.  
If the motor does not rotate in the required direction, exchange two phases.
  - Torque behaviour and current consumption.
  - Braking
  - Output signal of the tacho generator.
- In the event of faults or malfunctions see chapter 7

## 5.3 Connection

### 5.3.1 Power connection

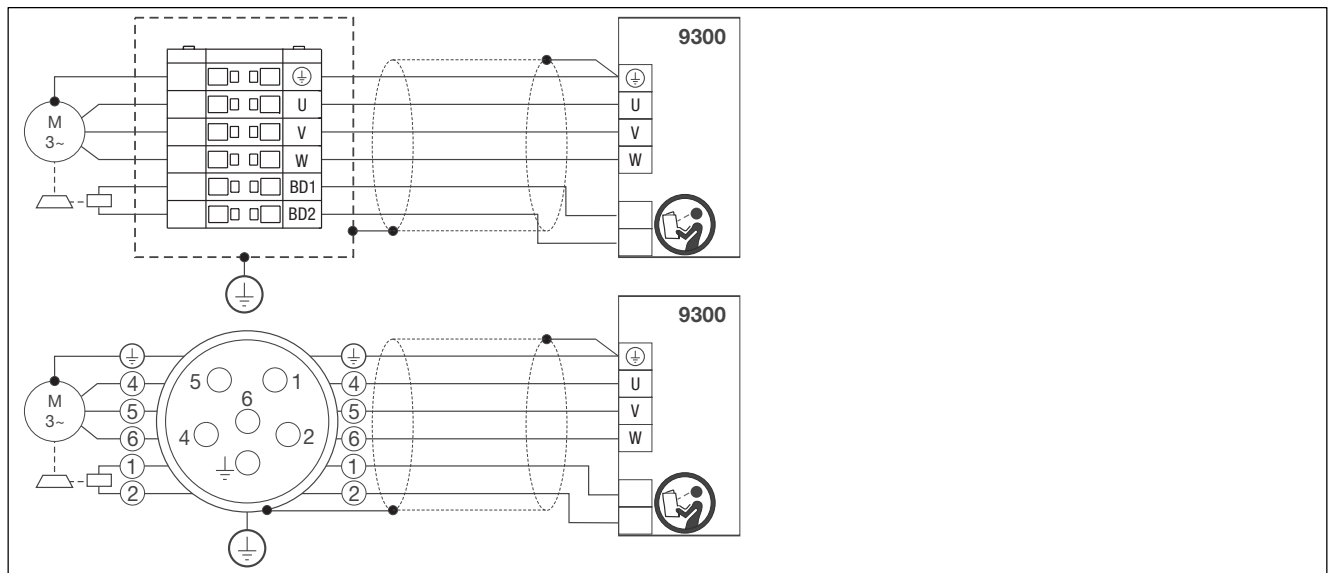

### 5.3.2 Resolver connection

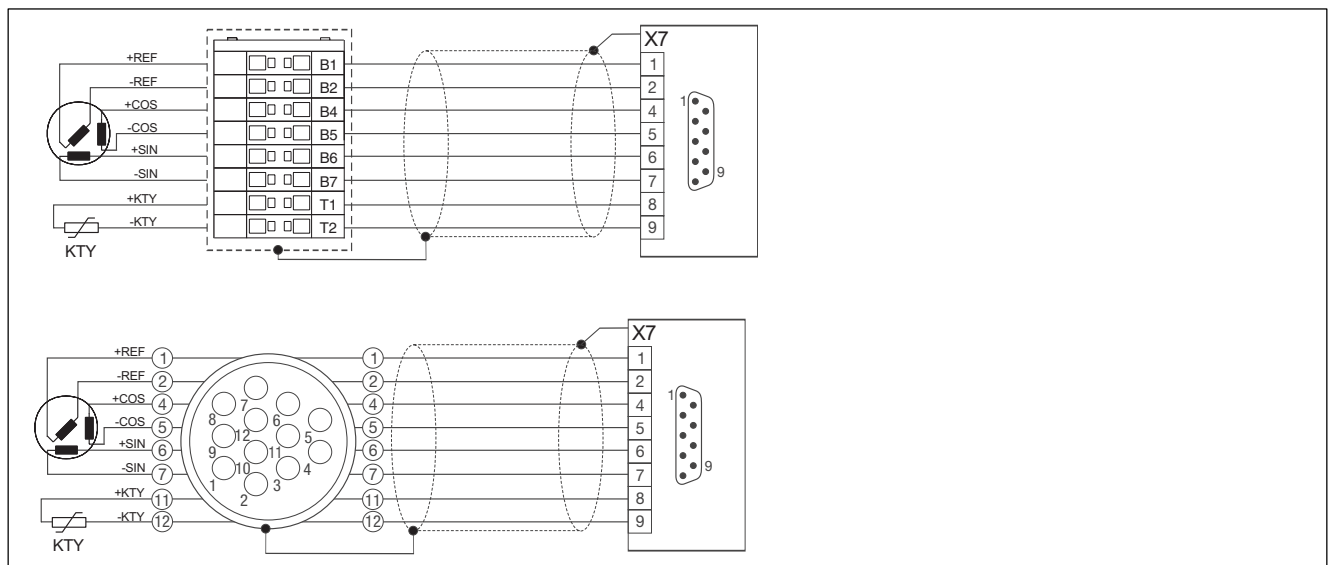

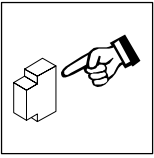

## ***During operation***

### **6 During operation**

Check the motor regularly during operation. Check the drives approximately every 50 operating hours. Pay attention to:

- Unusual noises
- Hot surfaces (temperatures up to 140°C may occur during normal operation).
- oil drops or leakages
- Irregular running
- Unusual vibrations
- Loose fixing elements
- State of the electrical cables
- Impeded heat dissipation
  - Deposits on the drive system and in the air ducts

For irregularities or faults see table in chapter 7



## 7 Fault detection and elimination

If faults occur during operation, take the following steps:

- Check the possible cause of the fault by means of the following table.
- Please observe the corresponding chapters in the Operating Instructions for the other components of the drive system.

If the fault cannot be eliminated as described in the table, please contact the Lenze Service.



### Danger!

- Ensure that no voltage is applied to the drive system while working on it!
- Hot motor surfaces, up to 140°C. Observe cooling times!
- Unload motor or secure loads applied to the drive!

Error	Cause	Remedy
<b>Motor too hot</b>  Measurement required; permissible surface temperatures: <ul style="list-style-type: none"> <li>• unventilated motors up to 140°C</li> <li>• forced or self ventilated motors up to 110 °C</li> </ul>	Motor is designed for star connection but connected in delta.	Correct connection
	Mains voltage is more than 10 % higher or lower than rated motor voltage. A higher voltage is extremely unfavourable for motors with many poles, since the idling current of these motors almost reaches the rated current even at a normal voltage.	Ensure appropriate mains voltage.
	Not enough cooling air, blocked air ducts.	Ensure unimpeded circulation of the cooling air.
	Prewarmed cooling air.	Ensure enough fresh cool air
	Overload; at normal mains voltage the current is too high and the speed is too low	Use larger drive (power measurement)
	Rated operating mode exceeded (S1 to S8 DIN 57530)	Adapt the operating mode to the prescribed operating conditions. As an expert or the Lenze Service for the correct drive.
	Cable with poor terminal connection (intermittent single-phase connection!)	Tighten loose contact.
<b>Motor does not start</b>	Fuse has blown (single-phase operation!)	Replace fuse
	Voltage supply interrupted	<ul style="list-style-type: none"> <li>• Check fault display at the controller</li> <li>• Check electrical connection (see chapter 4.2)</li> </ul>
	Controller inhibited	<ul style="list-style-type: none"> <li>• Check display at the controller</li> <li>• Check controller enable</li> </ul>
	Fuse blown	Replace fuse
	Motor protection activated	Check correct motor protection and if necessary adjust it
	Motor contactor is not working, fault in the control	Check control of the motor contactor and eliminate the fault
	Resolver cable interrupted	<ul style="list-style-type: none"> <li>• Check fault display at the controller</li> <li>• Check resolver cable</li> </ul>
	No brake release	Check electrical connection Check air gap (see Operating Instructions for the brake) Check the magnetic coil
	Drive blocked	Check the functionality of the components and if necessary remove foreign particles
Polarity reversal of motor cable	Check electrical connection	
<b>Motor stops suddenly and does not start again</b>	Only for MDXKS/MCS synchronous motor: <ul style="list-style-type: none"> <li>• Polarity reversal of motor cable</li> </ul> or <ul style="list-style-type: none"> <li>• resolver cable</li> </ul>	<ul style="list-style-type: none"> <li>• Make correct phase connection at the motor cable</li> </ul> and <ul style="list-style-type: none"> <li>• connect encoder correctly</li> </ul>
	Temperature monitoring is activated	<ul style="list-style-type: none"> <li>• Let motor cool down                             <ul style="list-style-type: none"> <li>– Reduce load by longer acceleration times</li> </ul> </li> </ul>
	Overload monitoring of the inverter is activated	<ul style="list-style-type: none"> <li>• Check controller settings</li> <li>• Reduce load by longer acceleration times</li> </ul>



## Troubleshooting and fault elimination

Error	Cause	Remedy
Wrong direction of rotation of the motor, correct display at the controller	Polarity reversal of motor and resolver cables	<ul style="list-style-type: none"> <li>• Exchange two phases of the motor cable</li> <li><b>and</b></li> <li>• the connection +COS/-COS of the resolver</li> </ul>
Motor rotates slowly in a direction which cannot be influenced via the controller (only for asynchronous motors MDXKA, MDFQA, MDXMA)	Polarity reversal of motor and resolver cables	<ul style="list-style-type: none"> <li>• Exchange two phases of the motor cable</li> <li><b>or</b></li> <li>• the connection +COS/-COS of the resolver</li> </ul>
Motor does not rotate, gearbox output is not running	Shaft-hub connection defective	Check the connection, replace the key, if necessary, repair by the manufacturer
	Toothing worn out	Repair by the manufacturer
Irregular running	Insufficient shielding of motor or resolver cable	Check shielding and grounding (see chapter 4.2.2)
	Gain of the controller too high	Adjust gains of the controllers (see Operating Instructions for the Controller)
Vibrations	Insufficiently balanced clutch elements or machine	Rebalance
	Misalignment of the drive train	Realign the machine set, if necessary, check the base
	Loose fixing screws	Check and tighten screw connections
Running noises	Foreign particles inside the motor	If necessary, repair by the manufacturer
	Bearing damage	If necessary, repair by the manufacturer
Surface temperature > 140 °C	Overload of the drive	<ul style="list-style-type: none"> <li>• Check load and, if necessary, reduce load by longer acceleration times</li> <li>• Check winding temperature (see chapter 8.2.2)</li> </ul>
	Heat dissipation impeded by deposits	Clean surface and cooling ribs of the drives



## 8 Maintenance/repair

### 8.1 Maintenance intervals

- In general, the motors are maintenance-free.
- Wear and tear appears on bearings and shaft seals only.
  - Check bearings for operating noise (after about 15,000 h at the latest).
  - Check shaft seals (after about 2,500 h at the latest): oil leaking at the motor between flange and housing? Replace after 2,500 to 3,000 operating hours.
- Dirt and deposits must be removed from the drives regularly to avoid overheating.
- We recommend to inspect the drive every 50 operating hours. It is thus possible to detect and remove irregularities and faults in time (see chapter 5.2).

### 8.2 Maintenance



#### Stop!

- Ensure that no foreign particles get into the motor!
- Ensure that no voltage is applied to the drive system while working on it!
- Separate the drive from the voltage supply!
- Hot motor surfaces, up to 140°C. Observe cooling times!
- Unload motor or secure loads applied to the drive!
- Never withdraw the connector while live!

#### 8.2.1 Resolver adjustment of synchronous servo motors

The resolvers of MDXKS synchronous servo motors have a factory setting that ensures trouble-free operation without adjustment at the controller.

If the resolver is out of position, e.g. because of changes at the motor, realign the resolver or adjust the rotor.

- For the **rotor adjustment** the motor must be free of load and rotate at the controller (see Operating Instructions of the controller). The rotor adjustment is stored in the controller and is valid only for one combination of motor and controller.
- **Resolver adjustment**
  1. If necessary, release the brake, free the motor shaft ends.
  2. Connect the resolver to the controller and detect the current rotor angle (see Operating Instructions for the controller).
  3. Let the DC ( $< I_{rated}$  of the motor) flow from phase V (positive connection) to phase W (negative connection). Phase U is free of current.
  4. Turn the resolver stator so that the controller displays the rotor angle "0".
  5. Fasten the resolver stator in this position.

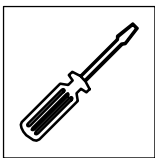

## Maintenance

### 8.2.2 Temperature check for servo motors

If the surface temperature is  $> 140\text{ }^{\circ}\text{C}$ , check the effective winding temperature:

- Measuring: 4-wire resistance measurement at the motor power connection
- The resistance should be measured immediately after switch-off and standstill of the servo motor.

#### Procedure

1. Disconnect the power plug-in connector X10. For terminal box versions, interrupt the power supply between inverter and motor.
2. Measure the resistance between the following contacts or terminals:
  - Plug-in connector X10:  
Contacts  $4\leftrightarrow 5$ ,  $5\leftrightarrow 6$  and  $6\leftrightarrow 4$
  - Terminal box X11:  
Terminals  $1\leftrightarrow 2$ ,  $2\leftrightarrow 3$  and  $3\leftrightarrow 1$
3. The mean value calculated from the three measuring values corresponds to the double phase resistance (star connection).
  - Use the mean values as  $R_{\text{operation}}$  and  $R_{\text{cold}}$  for the following equation to calculate the winding temperature  $\vartheta_{\text{operation}}$ :

$$\vartheta_{\text{operation}} [^{\circ}\text{C}] = \frac{R_{\text{operation}} \cdot 255}{R_{\text{cold}}} - 235$$

### 8.3 Repair

- We recommend that all repairs are carried out by Lenze.
- Spare parts will be delivered on request.

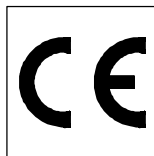

# Lenze

## Manufacturer's declaration

### in the sense of the EC Machinery Directive (98/37/EEC)

We herewith declare that the products listed below are intended for installation into a machine or for assembly with other elements into a machine. Commissioning of the machine is prohibited until its conformity with the rules and regulations of EC Directive 98/37/EEC has been established.

Lenze Drive Systems GmbH  
Postfach 10 13 52  
D-31763 Hameln

Site: Groß Berkel  
Hans-Lenze Straße 1  
D-31855 Aerzen  
Telephone (05154) 82-0  
Telefax (05154) 82-21 11

#### Product:

#### Type:

DC motors

MGFRK, MGFQU, MGFQK  
MGERK, MGEQU, MGEQK  
MGSRK, MGSQU, MGSQK

Asynchronous motors

DFRA, DERA, DSRA  
MDFMA, MDEMA, MDSMA  
MDXMAXM, MDXBAXM

Servo motors

DFVA, DSVA, MDFQA  
MDFKA, MDSKA  
MDFKS, MDSKS  
MCS

Three-phase winder motors

L12,  F12,  
 S8,  S6,  
 S4,  F4,  
 MF4,  SF4,  
 LF4

Applied standards and regulations are listed in the attachment.

Hameln, 28 August, 2002

(i. A. Fräger)  
Head of Engineering - Motors

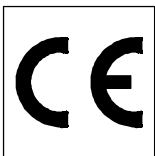

## **Manufacturer's declaration**

# Lenze

### **Manufacturer's declaration**

**in the sense of the EC Machinery Directive (98/37/EEC)**

#### **Applied standards and regulations:**

ISO 496, 1973-12	Shaft height for driving and driven machines
IEC 72 - IEC 72-1, 1991-02	Dimensions and performances for rotating electrical machines frame sizes 56 - 400; flange sizes 55 - 1080
DIN 42948, 1965-11	Mounting flanges for rotating electrical machinery
DIN 42955, 1981-12	Tolerances of shaft run-out and of mounting flanges for rotating electrical machinery
DIN 42961, 1980-06	Rating plates for rotating electrical machinery; design
DIN VDE 0100-100, 1982-05 (HD 384.1 S1-1979<H>)	Erection of power installations with nominal voltages up to 1000 V
IEC 34 - IEC 34-1, 1994-03 - IEC 34-5, 1991-01 - IEC 34-8, 1972-00 (with IEC 34-8 AMD 1, 1990-10) - IEC 34-9, 1990-06-00 (with IEC 34-9 AMD 1, 1995-04) - IEC 34-14, 1982-00-00 (with IEC 34-14 AMD 1, 1988-00)	Rotating electrical machines Rating and performance Degrees of protection (IP code) Terminal designations and direction of rotation  Noise limits  Mechanical vibration
ISO 8821, 1989-06	Mechanical vibration - balancing, shaft and fitment key convention
VDI 2056, 1964-10	Criteria for mechanical vibration of machines
DIN ISO 1940-1, 1993-12	Mechanical vibrations, balance quality requirements of rigid rotors



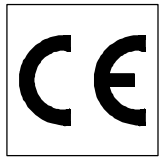

**Lenze**

**EC Declaration of Conformity '96**

**in the sense of the EC Low-Voltage Directive (73/23/EWG)**

amended by: CE Mark Directive (93/68/EWG)

The following products were developed, designed and manufactured in compliance with the above EC Directive under the sole responsibility of

**Lenze Drive Systems GmbH, Postfach 10 13 52, D-31763 Hameln**

Lenze Drive Systems GmbH  
Postfach 10 13 52  
D-31763 Hameln

Site:  
Groß Berkel  
Hans-Lenze Straße 1  
D-31855 Aerzen  
Telephone (05154) 82-0  
Telefax (05154) 82-21 11

**Product:**

**Type:**

DC motors

MGFRK, MGFQU, MGFQK  
MGERK, MGEQU, MGEQK  
MGSRK, MGSQU, MGSQK

Asynchronous motors

DFRA, DERA, DSRA  
MDFMA, MDEMA, MDSMA,  
MDXMAXM; MDXBAXM

Servo motors

DFVA, DSV A, MDFQA  
MDFKA, MDSKA  
MDFKS, MDSKS  
MCS

Three-phase winder motors

L12,  F12  
 S8,  S6  
 S4,  F4  
 MF4,  SF4  
 LF4

**Standards:**

EN 60204-1, IEC 204-1

EN 60034, VDE 0530, IEC34

**Declaration with respect to EMC Directive (89/336/EEC)**

If mains-operated on sinusoidal alternating voltage, asynchronous motors meet the requirements specified by the EC Directive "Electromagnetic compatibility" 89/336/EEC, taking into account standards EN 80081-1 and EN 50082-2.

It is vital to observe the inverter or DC speed controller manufacturer's EMC-specific information for inverter or DC speed controller operation.

When using shielded motor supply cables, the shields are most effective if a conductive connection is established over a large surface to the motor's earth potential (for example metal cable glands).

Hameln, 28 August, 2001

(i. A. Fräger)  
Head of Engineering - Motors