

SIEMENS

COMBIMASTER & MICROMASTER Integrated

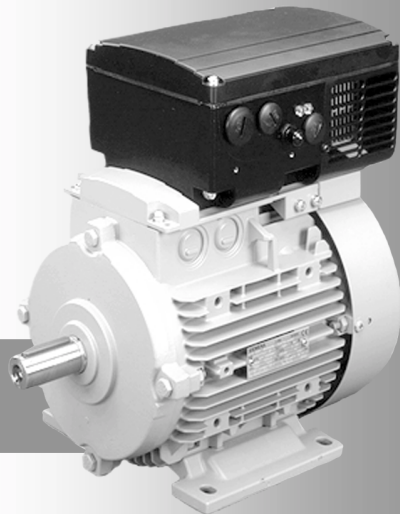

Operating Instructions

CONTENTS

Safety and CE Compliance	2
Installation	4
General Wiring Guidelines.....	4
Mechanical Installation COMBIMASTER	4
Mechanical Installation MICROMASTER Integrated.....	5
Electrical Installation MICROMASTER Integrated	5
Electrical Installation COMBIMASTER and MICROMASTER Integrated.....	6
Mains Cable Connections.....	6
Control Cable Connections.....	9
Drive Operation	10
General.....	10
Basic Operation	11
Operation - External Analogue Control.....	11
Operation - Digital Control	12
Stopping the Motor	12
If the Motor Does Not Start Up	12
Options / Accessories	13
Electrical Data COMBIMASTER	13
Electrical Data MICROMASTER Integrated	16
Parameter Summary List	17

Technical Data, selection and ordering data (order numbers), accessories & availability are subject to change.

SAFETY AND CE COMPLIANCE

Before installing and operating this equipment read these safety instructions and warnings carefully. Also read and obey all the warning signs attached to the equipment. Make sure that the warning labels are kept in a legible condition and replace any missing or damaged labels.



WARNING

This equipment must be installed, operated and maintained by suitably qualified personnel only.

Use only permanently-wired input power connections. The equipment must be grounded (IEC 536 Class 1, NEC and other applicable standards).

Wait at least five minutes after the power has been turned off, before opening the equipment. The dc-link capacitor remains charged to dangerous voltages even when the power is removed. When working on open equipment, note that live parts are exposed and do not touch these parts.

Some parameter settings can start the motor automatically when power is restored after a mains failure.

Do not connect machines with a three-phase power supply, fitted with EMC filters, to a supply via an ELCB (Earth Leakage Circuit Breaker - see EN50178, section 6.5).

Obey all general and regional installation and safety regulations relating to work on high voltage installations, as well as regulations covering correct use of tools and personal protective equipment.

Note that the following terminals can carry dangerous voltages even when the inverter is inoperative:

Power supply terminals L1, L2 and L3

Motor terminals U, V and W

When using the analogue input, the jumpers must be correctly set and the analogue input type selected (P023) before enabling the analogue input with P006. If this is not done the motor may start inadvertently.

This equipment is capable of providing internal motor overload protection in accordance with UL508C section 42.

This equipment is suitable for use in a circuit capable of delivering not more than 10,000 symmetrical amperes (rms), for a maximum voltage of 230V/480V/500V when protected by a time delay fuse (see Electrical Data for details).

Do not operate the equipment in direct sunlight.

This equipment must not be used as an 'emergency stop' mechanism (see EN 60204, 9.2.5.4).



CAUTION

Do not allow children or the general public to access or approach this equipment.

High voltage insulation test equipment must not be used on cables connected to the equipment.

Keep operating instructions within easy reach and give them to all users.

Use this equipment only for the purpose specified by the manufacturer. Do not carry out any modifications, or fit any spare parts which are not sold or recommended by the manufacturer; this could cause fires, electric shock or other injuries.



EUROPEAN LOW VOLTAGE & EMC DIRECTIVES

The COMBIMASTER product complies with the requirements of the Low Voltage Directive 73/23/EEC and the EMC Directive 89/336/EEC.

The units are certified for compliance with the following standards:

- EN 60204-1 Safety of machinery - Electrical equipment of machines
- EN 60146-1-1 Semiconductor converters - General requirements and line commutated converters

- BS EN50081-2: 1995 General Emission Standard - Industrial Environment
- BS EN50082-2: 1995 General Immunity Standard - Industrial Environment

The MICROMASTER Integrated product complies with the requirements of the Low Voltage Directive 73/23/EEC.

The units are certified for compliance with the following standards:

- EN 60204-1 Safety of machinery - Electrical equipment of machines
- EN 60146-1-1 Semiconductor converters - General requirements and line commutated converters

EUROPEAN MACHINERY DIRECTIVE

The MICROMASTER Integrated / COMBIMASTER products are suitable for incorporation into machinery.

The MICROMASTER Integrated / COMBIMASTER must not be put into service until the machinery into which it is incorporated has been certified to be in compliance with the provisions of the European Directive 89/392/EEC.

Note: Only valid for machinery to be operated in the European Community.

COMBIMASTER – UL CERTIFICATION



UL cUL listed power conversion equipment type 5B33 in accordance with UL508C.

For use in pollution degree 2 environment. (Applies to inverters only)

MICROMASTER Integrated – UR CERTIFICATION



UR cUR recognised power conversion equipment in accordance with UL508C.

For use in pollution degree 2 environment.

This equipment must be externally cooled by a fan, the rating of which depends on the unit Case Size. For Case Sizes A and B, the fan must provide 0.42m³/min and 1.25m³/min respectively.



ISO 9001

Siemens plc operates a quality management system which complies with the requirements of ISO 9001.

INSTALLATION



WARNING

Take note of the general and regional installation and safety regulations regarding work on high voltage installations (e.g. VDE). Adhere to relevant regulations regarding correct use of tools and protective gear.

Use the lifting eyes provided if a motor has to be lifted. Do not lift machine sets by suspending the individual machines! Always check the capacity of the hoist before lifting any equipment.

Do not paint over the black case finish of the inverter as this will affect the unit's thermal performance.

General Wiring Guidelines

The Case Size A (CS A) and Case Size B (CS B) COMBIMASTER and MICROMASTER Integrated are designed to operate in an industrial environment where a high level of Electro-Magnetic Interference (EMI) can be expected. Usually, good installation practices will ensure safe and trouble-free operation. However, if problems are encountered, the following guidelines may prove useful. In particular, grounding of the system 0V at the inverter, as described below, may prove effective.

- 1 All equipment must be well earthed using short, thick earthing cable connected to a common star point or busbar. It is particularly important that any control equipment connected to the inverter (such as a PLC) is connected to the same earth or star point as the inverter via a short, thick link. Flat conductors (e.g. metal brackets) are preferred as they have lower impedance at high frequencies.

- 2 Use screened leads for connections to the control circuitry. Terminate the ends of the cable neatly, ensuring that long strands of unscreened wire are not left visible.
- 3 Separate the control cables from the power connections as much as possible, using separate trunking, etc. If control and power cables cross, arrange the cables so that they cross at 90°.
- 4 Ensure that contactors are suppressed, either with R-C suppressors for AC contactors or 'flywheel' diodes for DC contactors, **fitted to the coils**. Varistor suppressors are also effective.

Safety regulations must not be compromised when installing the COMBIMASTER or MICROMASTER Integrated!

Mechanical Installation | COMBIMASTER



WARNING

Take suitable precautions to prevent transmission elements from being touched. If the COMBIMASTER is started up without a transmission element attached, the featherkey must be secured in position to prevent it from flying off while the shaft is rotating.

Tighten down screw-in lifting eyes prior to using the COMBIMASTER.

Stable foundations or mounting conditions and a well balanced transmission element are essential for quiet, vibration-free running. It may be necessary to balance the whole rotor and transmission element.

The rotors are dynamically balanced with a full featherkey inserted as standard. Since 1991 the type of balance has been marked on the drive end of the shaft (shaft end face). **F** denotes balanced with **full** featherkey; **H** denotes balanced with **half** featherkey. Bear in mind the type of balance used when fitting the transmission element.

Poor running characteristics can arise in cases where the transmission elements have a length ratio of hub length to shaft end length < 0.8 and they run at speeds greater than 1500 rpm. In such cases rebalancing may be necessary, e.g. by reducing the distance by which the featherkey protrudes from the transmission element and the shaft surface.

Please check the following prior to commissioning:

- The rotor turns freely without rubbing.
- The motor is assembled and aligned properly.
- The transmission elements are adjusted correctly (e.g. belt tension) and the transmission element is suitable for the given operating conditions.

- All electrical connections, mounting screws and connecting elements are tightened and fitted correctly.
- All protective conductors are installed properly.
- Any auxiliary equipment that might be fitted (e.g. mechanical brake) is in working order.
- Protection guards are installed around all moving and live parts.
- The maximum speed (*see motor rating plate*) is not exceeded. The maximum speed is the highest operating speed permitted. Remember that motor noise and vibration are worse at this speed and bearing life is reduced.

The above list is not meant to be exhaustive - additional checks may also be required.

Mechanical Installation | MICROMASTER Integrated

The motor / MICROMASTER Integrated combination should be installed according to guidelines similar to those given above for the COMBIMASTER.

First fit the Motor Interface Plate (MIP) to the motor. In most cases the MIP makes use of the existing motor gasket. Refer to Siemens Document 'MMI Motor Adaptation Guidelines' (English) – (Available 2nd Qtr 1999.– G85139-H1731-U500-A1.

Electrical Installation | MICROMASTER Integrated

The motor wires should be connected in either star or delta configuration on the MIP

(check motor rating plate).

Star Connection

Wire	Terminal
U2/V2/W2	N
U1	U
V1	V
W1	W

Star connection

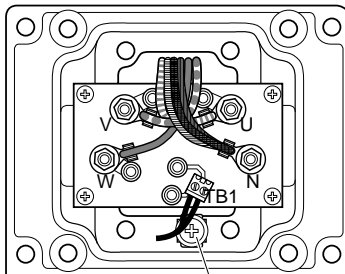

Earth connection

Delta Connection

Wire	Terminal
U1/W2	U
U2/V1	V
V2/W1	W

Delta connection

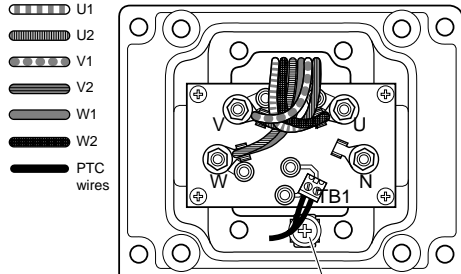

Earth connection

Figure 1 Motor Wire Connection



WARNING

It is essential that the MIP is correctly earthed to the motor. This is usually achieved using a short earth cable connected between the MIP and a suitable connection point on the motor. Death or severe injury can result if the motor is not correctly earthed. Incorrect earthing can also prevent any MICROMASTER Integrated built-in EMC filter from operating correctly.

Electrical Installation | COMBIMASTER and MICROMASTER Integrated

Remove the four M5 cross-head screws on the inverter's cover to access the electrical terminals (see Figs 2 and 3).

Notes: Refer to the Electrical Data tables for cable sizes.

A 'drip loop' is recommended when connecting the mains and control cables (see Fig. 6).



CAUTION

The printed circuit boards contain CMOS components that are particularly sensitive to static electricity. For this reason, avoid touching the boards or components with hands or metal objects.

Mains Cable Connections

Ensure that the power source supplies the correct voltage and is designed for the rated current. Use the appropriate circuit-breakers with the specified current rating between the power supply and inverter.

Use Class 1 60/75°C copper wire only. Use a 4-core screened cable. If crimp terminals are used they must be insulated. If crimps are not used, the strip length must not exceed 5mm.

Feed the power cable into the inverter via the gland hole nearest to the motor shaft.

Connect the power leads to terminals L1, L2, L3 (L1, L2 for single phase units) and the separate earth.

Use a 4 - 5 mm cross-tip screwdriver to tighten the terminal screws.

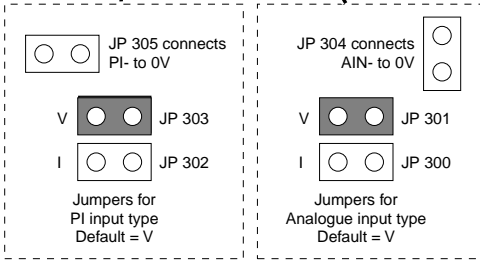
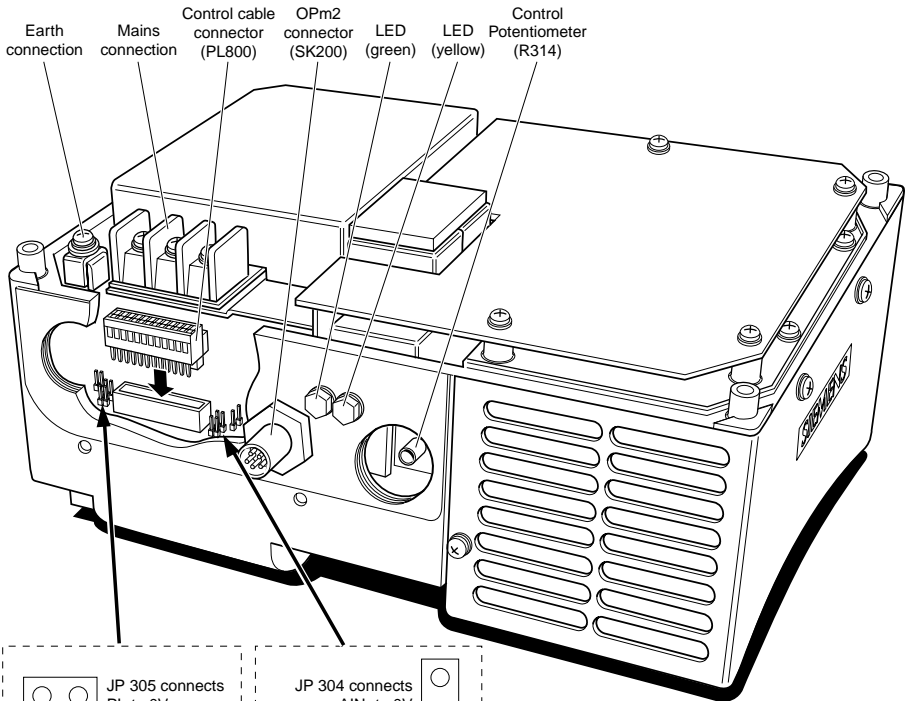

Note: Jumper in 'V' position = voltage input (default)
Jumper in 'I' position = current input

Figure 2 Electrical Connection (CS B)

Check that the supply voltage is correct for the inverter used by referring to the rating label.

Cable Glands (Case Size B)	PG21(Mains) PG16(Signal)
----------------------------	-----------------------------

IMPORTANT

Ensure that the following tightening torques are used:

Access cover retaining screws	4.0Nm
Gland hole covers:	1.0Nm
Mains connector screws	1.0Nm
Earth Connection	1.5Nm

Note: Jumper in 'V' position = voltage input (default)
 Jumper in 'I' position = current input

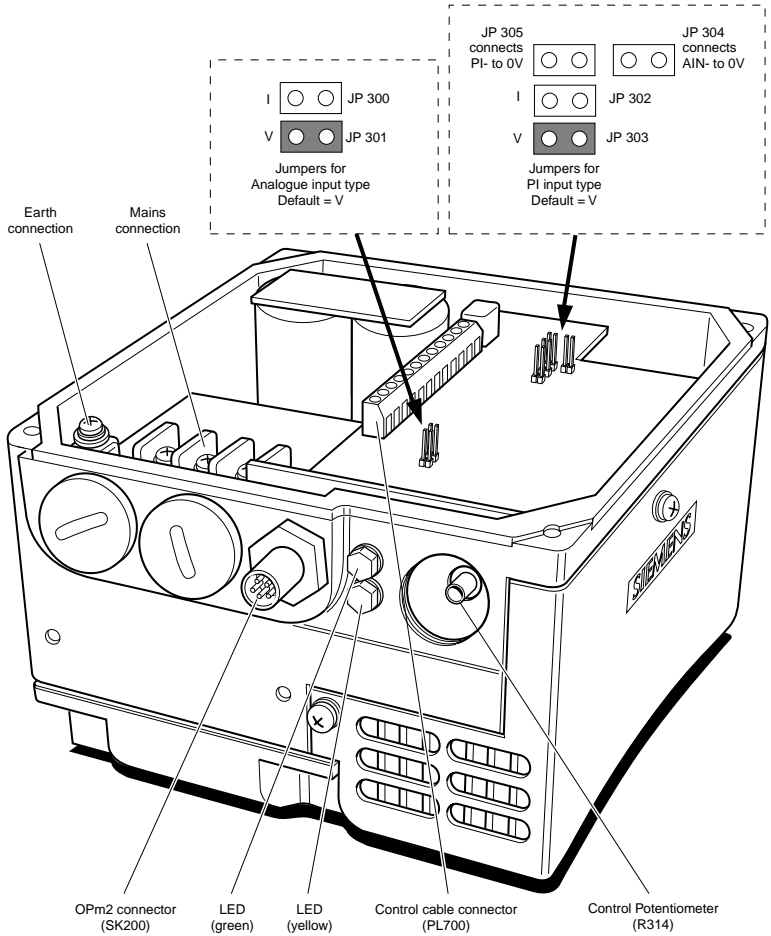

Figure 3 Electrical Connection (CS A)

Check that the supply voltage is correct for the inverter used by referring to the rating label.

Cable Glands (Case Size A) PG16

IMPORTANT	
Ensure that the following tightening torques are used:	
Access cover retaining screws	4.0Nm
Gland hole covers:	1.0Nm
Mains connector screws	1.0Nm
PL700 Screws	0.5Nm
Earth Connection	1.5Nm

Control Cable Connections



CAUTION

The control and power supply cables must be laid separately. They must not be fed through the same cable conduit / trunking.

Use screened cable for the control lead.

Feed the control cable into the inverter via the appropriate gland hole. Connect the control wires in accordance with the information in Figures 4,5 and 6 having first unplugged connector block PL800 from the PCB (CS B only).

IMPORTANT: A wire link **must** be fitted between control terminals 5 (DIN1) and 1 (P10+) if it is required to start the inverter from the control potentiometer R314, or the analogue input. The wire link must be removed when operation via a run/stop switch is required.

Note that the optional potentiometer fitted as an analogue set point shown in Figure 4 assumes that jumper JP304 is connecting 0V (pin 2) to AIN- (pin 4).

Also, +15V can be used as an alternative to P10+ for the digital inputs.

Plug the connector block back into the PCB (CS B only), refit the cover and tighten the four securing screws.

COMBIMASTER Control Terminals Cabling Information		
	CS A (PL700):	CS B (PL800)
Cable AWG	22 - 18	28 - 20
= approx. mm ²	0.35 - 0.82	0.08 - 0.50
Strip length (mm)	5 - 6	5 - 6
Strip length (inch)	0.22	0.22

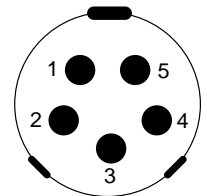
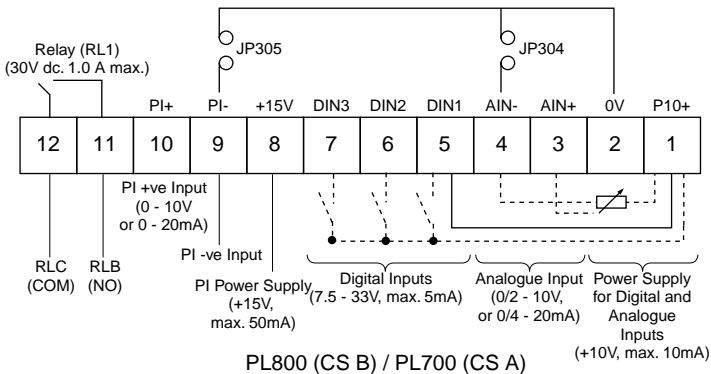

- 1 - +5V (250mA max.)
- 2 - N (-)
- 3 - 0V
- 4 - P (+)
- 5 - no connection

SK200 Socket

Figure 4 Control Terminal Connections

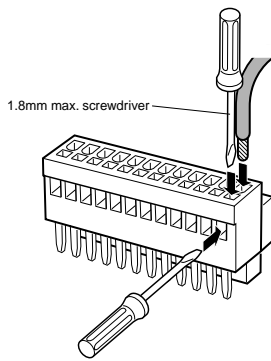

Figure 5 Connecting Control Wires to PL800

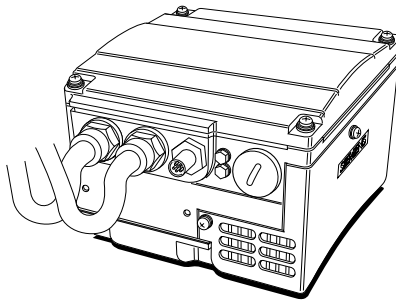

Figure 6 Cable Connections with Drip Loop

DRIVE OPERATION



WARNING

The equipment must not be switched on until after its cover has been fitted and the cover screws have been tightened to the correct torque (see Fig. 2 & 3).

After the power has been turned off, you must always wait five minutes so that the dc link capacitors can discharge. Do not remove the cover until this time has elapsed.

All settings must be only entered by qualified personnel, paying particular attention to the safety precautions and warnings.

General

For basic operation of COMBIMASTER, no additional equipment is required. However, for more complex operation, OPm2 – Clear Text Display is required (OPm2 is available as an option, but must be ordered separately).

The inverter does not have a mains power switch and is therefore live when the mains supply is connected.

When delivered, the inverter has a frequency setpoint range of between 0 Hz and 50 Hz. Regardless of its initial position, internal potentiometer R314 must be turned fully counter-clockwise before it will start the inverter.

R314 can be accessed by removing the right-hand gland hole cover (see Fig. 2 & 3). Analogue input type is selected by jumpers JP300 and JP301. JP300 closed selects current input, JP301 closed (default) selects voltage input. These jumpers can only be accessed when the cover is removed (see Fig. 2 & 3).

If the motor is run unloaded (e.g. for test purposes) and vibration or trip conditions occur, change P077 from 0 to 3 (requires OPm2).

Basic Operation

There are two basic modes of operation for the inverter.

- 1 Using the internal potentiometer only:
 - a For forward rotation, ensure that a link is fitted between DIN1 (pin 5) and P10+ (pin 1) on PL800/PL700 (see Fig. 4). For reverse rotation, connect the link to DIN2 (pin 6) instead of DIN1.
 - b Apply mains power. The green and yellow LEDs will illuminate to show that power is applied. Turn potentiometer R314 fully counter-clockwise, otherwise the COMBIMASTER cannot be started.
 - c Turn the potentiometer clockwise until the yellow LED extinguishes. This indicates that power is now applied to the motor. Continue turning clockwise to increase the speed of the motor.
 - d Turn the potentiometer counter-clockwise to reduce the speed of the motor. Turning the potentiometer fully counter-clockwise causes the motor to slow to a complete stop. Check that both LEDs are illuminated (STANDBY mode).

- 2 Using a combination of the internal potentiometer and a run/stop switch:

- a Connect a run/stop switch between DIN1 (pin 5) and P10+ (pin 1) on PL800 (see Fig. 4) if forward rotation is required. If reverse rotation is required instead, connect the switch to DIN2 (pin 6) instead of DIN1.

IMPORTANT: Remove the link, if fitted, between pins 5 and 1 before the run/stop switch is fitted.

- b Apply mains power. The green and yellow LEDs will illuminate to show that power is applied.
- c Set the external run/stop switch to ON.
- d Turn potentiometer R314 clockwise to set the required motor speed.
- e Stop the motor by setting the external on/off switch to OFF. When the switch is set to ON again, it will run at the speed previously set using the potentiometer.

Operation - External Analogue Control

- 1 Connect a 4.7 kΩ potentiometer to the control terminals as shown in Fig. 4 or apply a 0 - 10 V signal between pin 2 (0V) and pin 3 (AIN+). In both cases, position jumper JP304 to connect 0V to AIN-.
- 2 Ensure that a link is fitted between pin 5 (DIN1) and pin 1 (P10+).
- 3 Check that voltage input is selected by ensuring that the jumper is fitted to JP301.
- 4 Refit the cover, tighten the cover screws to the correct torque and then apply mains power to the inverter.

- 5 Turn the external potentiometer (or adjust the analogue control voltage) until the desired frequency is achieved. The unit will not switch on until a minimum of 2 V has been applied.

Note: The frequency set by the external voltage is added to the frequency set by the internal potentiometer.

As with Basic Operation (2), a run/stop switch can be used to start and stop the motor, or the direction of rotation can be changed by connecting the link to DIN2 instead of DIN1.

Operation - Digital Control

This method of operation requires either a Clear Text Display (OPm2) or a serial link connection. For a basic startup configuration using digital control, proceed as follows:

- 1 Remove the link that connects control terminal 5 to terminal 1 (if one has been fitted).
- 2 Connect control terminal 5 to terminal 1 via a simple on/off switch. This sets up the inverter for clockwise rotation (default). If counter-clockwise operation is required, connect a switch between control terminals 6 and 1.
- 3 Connect the OPm2 or serial link to SK200. Refit the cover, tighten the cover screws to the correct torque and then apply mains power to the inverter.
- 4 Set parameter P006 to 000 to specify digital setpoint.
- 5 Set parameter P005 to the desired frequency setpoint.
- 6 Set the external on/off switch to ON or press the ON button on the OPm2 (set P007 = 001 to use the OPm2). The inverter will now run at the frequency set by P005.

Stopping the Motor

Via the external on/off switch: Setting the switch to OFF overrides the setting on the potentiometer and causes the motor to come to a controlled stop.

Via the potentiometer: Turning the potentiometer counter-clockwise until the input voltage drops below 2 V causes the motor to slow to a stop. . If an external potentiometer is applied, the input voltage must also be below 2V to stop.

If the Motor Does Not Start Up

Check the LEDs on the side of the inverter:

LED State	COMBIMASTER / MICROMASTER Integrated Status	
Green	Yellow	
ON	ON	Mains power on, inverter not running (STANDBY)
ON	OFF	Inverter running, as per control commands (ON)
Flashing	Flashing	Current limit warning
Flashing	ON	Inverter overtemperature (PTC)
ON	Flashing	Motor overtemperature
OFF	ON	Other fault (e.g. tripped)
OFF	Flashing	Mains undervoltage
OFF	OFF	Mains supply fault (e.g. faulty external switch)

If a fault occurs:

Switch off, disconnect and then reconnect the power, and then switch on again. Switch off if the fault condition persists. Trips can be reset by using DIN3.

If a warning occurs:

Switch off, disconnect and reconnect the power and then switch on again.
If the fault/warning persists, further investigation requires an OPm2 or a serial link connection.

OPTIONS / ACCESSORIES



Description:	Order Number:	Shortcode: (for ordering with unit)
Clear Text Display (OPm2)	6SE3290-0XX87-8BF0	
Interface cable for OPm2 - 3m screened	6SE9996-0XA31	
Reference Manual	6SE9996-0XA35	
PROFIBUS Module (CB155) <i>Note : For CS B , Issue A units :</i>	6SE9996-0XA18 <i>use : 6SE9996-0XA20</i>	
PROFIBUS T-Connector	6SE9996-0XA21	
PROFIBUS Terminator	6SE9996-0XA22	
PROFIBUS Cable - 1m	6SE9996-0XA23	
PROFIBUS Cable - 5m	6SE9996-0XA24	
PROFIBUS Cable - 10m	6SE9996-0XA25	
PROFIBUS Cable Link	6SE9996-0XA26	
CS A Inverter Fan Option (MICROMASTER Integrated only)	6SE9996-0XA01	M41
CS B Inverter Fan Option (MICROMASTER Integrated only)	6SE9996-0XA02	M41
CS A Electro-mechanical Brake Control Unit <i>(Note :Expected Product release: August 1999)</i>	6SE9996-0XA07	
CS B Electro-mechanical Brake Control Unit	6SE9996-0XA10	
CS B Pulse Resistor Braking Unit	6SE9996-0XA11	
SIMOVIS PC Software	6SE3290-0XX87-8SA2	

Note:

CS A covers power range 120W to 1.5kW

CS B covers power range 1.5kW to 7.5kW



ELECTRICAL DATA | COMBIMASTER

CS A Low Voltage Single Phase Units

Model:	CM12	CM25	CM37	CM55	CM75
Order Number:					
2 pole	1UA7053-2B[z]0.	1UA7063-2B[z]0.	1UA7070-2B[z]0.	1UA7073-2B[z]0.	1UA7080-2B[z]0.
4 pole	1UA7060-4B[z]0.	1UA7070-4B[z]0.	1UA7073-4B[z]0.	1UA7080-4B[z]0.	1UA7083-4B[z]0.
Frame size:					
2 pole	56	63	71	71	80
4 pole	63	71	71	80	80
Motor Output Rating:	0.12kW 0.16hp	0.25kW 0.33hp	0.37kW 0.49hp	0.55kW 0.73hp	0.75kW 1.0hp
Operating Input Voltage:	1∅ AC 208 – 240 V _{rms} ± 10%				
Operating Input Frequency:	47 – 63 Hz				
Output Frequency:	0 – 50Hz				
Output Frequency with Op2 or serial link:					
2 pole	0 – 100Hz	0 – 100Hz	0 – 100Hz	0 – 100Hz	0 – 100Hz
4 pole	0 – 140Hz	0 – 140Hz	0 – 140Hz	0 – 140Hz	0 – 140Hz
Input Current:	1.8 A _{rms}	3.2 A _{rms}	4.6 A _{rms}	6.2 A _{rms}	8.2 A _{rms}
Mains fuse:	10 A				
Mains Lead cross-section	1mm ²				

* [z] = filter option: U = Unfiltered, A = Class A filter, B = Class B filter.

Position 12 (shown as ".") is for the construction type from the Siemens M11 catalogue.(ref.: E2002-K1711-A201-A2-7600)

CS A Low Voltage Three Phase Units

Model:	CM12/2	CM25/2	CM37/2	CM55/2	CM75/2
Order Number: *					
2 pole	1UA7053-2BU1.	1UA7063-2BU1.	1UA7070-2BU1.	1UA7073-2BU1.	1UA7080-2BU1.
4 pole	1UA7060-4BU1.	1UA7070-4BU1.	1UA7073-4BU1.	1UA7080-4BU1.	1UA7083-4BU1.
Frame size: *					
2 pole	56	63	71	71	80
4 pole	63	71	71	80	80
Motor Output Rating:	0.12kW 0.16hp	0.25kW 0.33hp	0.37kW 0.49hp	0.55kW 0.73hp	0.75kw 1.0hp
Operating Input Voltage:	3∅ AC 208 – 240 V _{rms} ± 10%				
Operating Input Frequency:	47 – 63 Hz				
Output Frequency:	0 – 50Hz				
Output Frequency with Op2 or serial link:					
2 pole	0 – 100Hz	0 – 100Hz	0 – 100Hz	0 – 100Hz	0 – 100Hz
4 pole	0 – 140Hz	0 – 140Hz	0 – 140Hz	0 – 140Hz	0 – 140Hz
Input Current:	1.1 A _{rms}	1.9 A _{rms}	2.7 A _{rms}	3.6 A _{rms}	4.7 A _{rms}
Mains fuse:	10 A				
Mains Lead cross-section	1mm ²				

* Note that these units are available Unfiltered only.

Position 12 (shown as ".") is for the construction type from the Siemens M11 catalogue.(Ref.: see above)

CS A High Voltage Three Phase Units

Model:	CM37/3	CM55/3	CM75/3	CM110/3	CM150/3
Order Number: *					
2 pole	1UA7070-2B[zz].	1UA7073-2B[zz].	1UA7080-2B[zz].	1UA7083-2B[zz].	1UA7090-2C[zz].
4 pole	1UA7073-4B[zz].	1UA7080-4B[zz].	1UA7083-4B[zz].	1UA7090-4B[zz].	1UA7096-4C[zz].
Frame size:					
2 pole	71	73	80	80	90S
4 pole	71	80	80	90S	90L
Motor Output	0.37kW	0.55kW	0.75kW	1.1kW	1.5kW
Rating:	0.49hp	0.73hp	1.0hp	1.5hp	2.0hp
Operating Input Voltage:	3∅ AC 380 – 500 V _{rms} ± 10% (all units)		3∅ AC 380 – 480 V _{rms} ± 10% (filtered units only)		
	Torque derating required below 380Vrms				
Operating Input Frequency:	47 – 63 Hz				
Output Frequency:	0 – 50Hz				
Output Frequency with Opm2 or serial link:					
2 pole	100 Hz	100Hz	100Hz	100Hz	100Hz
4 pole	140Hz	140Hz	140Hz	140Hz	140Hz
Input Current:	2.2 A _{rms}	2.8 A _{rms}	3.7 A _{rms}	4.9 A _{rms}	5.9 A _{rms}
Mains fuse:	10 A				
Mains Lead cross-section	1mm ²				

* [zz] = filter option: U = Unfiltered, A = Class A filter, B = Class B filter and mains voltage code: 2 = 380 – 500V, 3 = 460 – 500V/60Hz . Allowed combinations: A2, B2, U2 and U3.

Position 12 (shown as “.”) is for the construction type from the Siemens M11 catalogue. (Ref.: see above)

CS B High Voltage Three Phase Units

Model:	CM150/3	CM220/3	CM300/3	CM400/3	CM550/3	CM750/3
Order Number: *						
2 pole	1UA7090-2B[zz].	1UA7096-2B[zz].	1UA7106-2B[zz].	1UA7113-2B[zz].	1UA7130-2B[zz].	1UA7131-2B[zz].
4 pole	1UA7096-4B[zz].	1UA7106-4B[zz].	1UA7107-4B[zz].	1UA7113-4B[zz].	1UA7130-4B[zz].	1UA7133-2B[zz].
Frame size:						
2 pole	90S	90L	100L	112M	132S	132S
4 pole	90L	100L	100L	112M	132S	132M
Motor Output	1.5kW	2.2kW	3.0kW	4.0kW	5.5kW	7.5kW
Rating:	2.0hp	2.9hp	4.0hp	5.3hp	7.3hp	10.0hp
Operating Input Voltage:	3∅ AC 380 – 500 V _{rms} ± 10% (all units)		3∅ AC 380 – 480 V _{rms} ± 10% (filtered units only)			
	Torque derating required below 380Vrms					
Operating Input Frequency:	47 – 63 Hz					
Output Frequency:	0 – 50Hz					
Output Frequency with Opm2 or serial link:						
2 pole	100 Hz	100Hz	100Hz	100Hz	90Hz	90Hz
4 pole	140Hz	140Hz	140Hz	140Hz	140Hz	140Hz
Input Current:	3.5 A _{rms}	4.7 A _{rms}	6.4 A _{rms}	10.0 A _{rms}	12.2 A _{rms}	16.0 A _{rms}
Mains fuse:	10 A		16 A		20 A	
Mains Lead cross-section	1mm ²		1.5mm ²		2.5mm ²	

* [zz] = filter option: U = Unfiltered, A = Class A filter, B = Class B filter and mains voltage code: 2 = 380 – 500V, 3 = 460 – 500V/60Hz . Allowed combinations: A2, B2, U2 and U3.

Position 12 (shown as “.”) is for the construction type from the Siemens M11 catalogue. (Ref.: see above)

ELECTRICAL DATA | MICROMASTER Integrated

CS A Low Voltage Single Phase Units

Model:	MI12	MI25	MI37	MI55	MI75
Order Number: *	6SE9610-7BF[y]0-Z=C87	6SE9611-5BF[y]0-Z=C87	6SE9612-0BF[y]0-Z=C87	6SE9612-6BF[y]0-Z=C87	6SE9613-4BF[y]0-Z=C87
Motor Output Rating:	0.12kW 0.16hp	0.25kW 0.33hp	0.37kW 0.49hp	0.55kW 0.73hp	0.75kW 1.0hp
Operating Input Voltage:	1∅ AC 208 – 240 V _{rms} ± 10%				
Operating Input Frequency:	47 – 63 Hz				
Output Frequency:	0 – 50Hz				
Output Frequency with Opm2 or serial link:	0 – 400Hz				
Input Current:	1.8 A _{rms}	3.2 A _{rms}	4.6 A _{rms}	6.2 A _{rms}	8.2 A _{rms}
Mains fuse:	10 A				16 A
Mains Lead cross-section	1mm ²				1.5mm ²

* [y] = filter option: 1 = Unfiltered, 5 = Class A filter, 6 = Class B filter.

CS A Low Voltage Three Phase Units

Model:	MI12/2	MI25/2	MI37/2	MI55/2	MI75/2
Order Number: *	6SE9610-7CF10-Z=C87	6SE9611-5CF10-Z=C87	6SE9612-0CF10-Z=C87	6SE9612-6CF10-Z=C87	6SE9613-4CF10-Z=C87
Motor Output Rating:	0.12kW 0.16hp	0.25kW 0.33hp	0.37kW 0.49hp	0.55kW 0.73hp	0.75kW 1.0hp
Operating Input Voltage:	3∅ AC 208 – 240 V _{rms} ± 10%				
Operating Input Frequency:	47 – 63 Hz				
Output Frequency:	0 – 50Hz				
Output Frequency with Opm2 or serial link:	0 – 400Hz				
Input Current:	1.1 A _{rms}	1.9 A _{rms}	2.7 A _{rms}	3.6 A _{rms}	4.7 A _{rms}
Mains fuse:	10 A				
Mains Lead cross-section	1mm ²				

* Note that these units are available Unfiltered only.

CS A High Voltage Three Phase Units

Model:	MI37/3	MI55/3	MI75/3	MI110/3	MI150/3
Order Number: *	6SE9611-1DF[y]0-Z=C87	6SE9611-4DF[y]0-Z=C87	6SE9611-8DF[y]0-Z=C87	6SE9612-7DF[y]0-Z=C87	6SE9613-7DF[y]0-Z=C87
Motor Output Rating:	0.37kW 0.49hp	0.55kW 0.73hp	0.75kW 1.0hp	1.1kW 1.5hp	1.5kW 2.0hp
Operating Input Voltage:	3∅ AC 380 – 500 V _{rms} ± 10% (all units) 3∅ AC 380 – 480 V _{rms} ± 10% (filtered units only)				
Operating Input Frequency:	47 – 63 Hz				
Output Frequency:	0 – 50Hz				
Output Frequency with Opm2 or serial link:	0-400Hz				
Input Current:	2.2 A _{rms}	2.8 A _{rms}	3.7 A _{rms}	4.9 A _{rms}	5.9 A _{rms}
Mains fuse:	10 A				
Mains Lead cross-section	1mm ²				

* [y] = filter option: 1 = Unfiltered, 5 = Class A filter, 6 = Class B filter.

CS B High Voltage Three Phase Units

Model:	MI150/3	MI220/3	MI300/3	MI400/3	MI550/3	MI750/3
Order Number: *	6SE9613-7DD[y]0-Z=C87	6SE9615-8DD[y]0-Z=C87	6SE9617-3DD[y]0-Z=C87	6SE9621-1DD[y]0-Z=C87	6SE9621-3DD[y]0-Z=C87	6SE9621-7DD[y]0-Z=C87
Motor Output Rating:	1.5kW 2.0hp	2.2kW 2.9hp	3.0kW 4.0hp	4.0kW 5.3hp	5.5kW 7.3hp	7.5kW 10.0hp
Operating Input Voltage:	3∅ AC 380 – 500 V _{rms} ± 10% (all units) 3∅ AC 380 – 480 V _{rms} ± 10% (filtered units only)					
Operating Input Frequency:	47 – 63 Hz					
Output Frequency:	0 – 50Hz					
Output Frequency with Opm2 or serial link:	0-400Hz					
Input Current:	3.5 A _{rms}	4.7 A _{rms}	6.4 A _{rms}	10.0 A _{rms}	12.2 A _{rms}	16.0 A _{rms}
Mains fuse:	10 A		16 A		20 A	
Mains Lead cross-section	1mm ²		1.5mm ²		2.5mm ²	

* [y] = filter option: 1 = Unfiltered, 5 = Class A filter, 6 = Class B filter.

PARAMETER SUMMARY LIST

This list is applicable for operation using Opm2 – Clear Text Display (optional).

● = Parameter can be changed during operation.

☆☆☆ = Value depends on the rating of the motor.

Parameter	Function	Default	Parameter	Function	Default
P000	Operating display	-	P043 ●	Fixed frequency 3 (Hz)	15.00
P001 ●	Display mode	0	P044 ●	Fixed frequency 4 (Hz)	20.00
P002 ●	Ramp up time (seconds)	10.00	P045	Inversion fixed setpoints for fixed frequencies 1 – 4	0
P003 ●	Ramp down time (seconds)	25.00	P046 ●	Fixed frequency 5 (Hz)	25.00
P004 ●	Smoothing (seconds)	0.0	P047 ●	Fixed frequency 6 (Hz)	30.00
P005 ●	Digital frequency setpoint (Hz)	50.00	P048 ●	Fixed frequency 7 (Hz)	35.00
P006	Frequency setpoint source selection	1	P050	Inversion fixed setpoints for fixed frequencies 5 – 7	0
P007	Keypad control	0	P051	Selection control function (DIN1 – terminal 5) fixed frequency 3 or binary fixed frequency bit 0	1
P009 ●	Parameter protection setting	0	P052	Selection control function (DIN2 – terminal 6) fixed frequency 2 or binary fixed frequency bit 1	2
P011	Frequency setpoint memory	0	P053	Selection control function (DIN3 – terminal 7) fixed frequency 1 or binary fixed frequency bit 2	10
P012 ●	Minimum motor frequency (Hz)	0.00	P056	Digital input debounce time	0
P013 ●	Maximum motor frequency (Hz)	50.00	P058 ●	RUN command delay (seconds)	0.0
P014 ●	Skip frequency 1 (Hz)	0.00	P061	Selection relay output RL1	6
P015 ●	Automatic restart after mains failure	0	P062	Electro-mechanical brake option control	0
P016 ●	Start on the fly	0	P063	External brake release delay (seconds)	1.0
P017 ●	Smoothing type	1	P064	External brake stopping time (seconds)	1.0
P018 ●	Automatic restart after fault	0	P065	Current threshold for relay (A)	1.0
P019 ●	Skip frequency bandwidth (Hz)	2.00	P071 ●	Slip compensation (%)	0
P020	Flying start ramp time (seconds)	25.00	P072 ●	Slip limit (%)	500
P021 ●	Minimum analogue frequency (Hz)	0.00	P073 ●	DC injection braking (%)	0
P022 ●	Maximum analogue frequency (Hz)	50.00	P074 ●	I ² t motor derating	0
P023 ●	Analogue input type	2	PO76	Pulse Frequency	0 or 2
P024 ●	Analogue setpoint addition	0	P077	Control mode	0
P027 ●	Skip frequency 2 (Hz)	0.00	P078 ●	Continuous boost (%)	50
P028 ●	Skip frequency 3 (Hz)	0.00	P079 ●	Starting boost (%)	0
P029 ●	Skip frequency 4 (Hz)	0.00	P081	Nominal frequency for motor (Hz)	☆☆☆
P031 ●	Jog frequency right (Hz)	5.00	P082	Nominal speed for motor (RPM)	☆☆☆
P032 ●	Jog frequency left (Hz)	5.00	P083	Nominal current for motor (A)	☆☆☆
P033	Jog Ramp Up time (V3.00)	10.00	P084	Nominal voltage for motor (V)	☆☆☆
P034	Jog Ramp Down time (V3.00)	10.00			
P035	Reverse motor direction	0			
P041 ●	Fixed frequency 1 (Hz)	5.00			
P042 ●	Fixed frequency 2 (Hz)	10.00			

Parameter	Function	Default	Parameter	Function	Default
P085	Nominal power for motor (kW/hp)	☆☆☆	P152 ●	Yellow LED function	5
P086 ●	Motor current limit (%)	150	P201	PI closed loop mode	0
P087	Motor PTC enable	0	P202 ●	P gain (%)	1.0
P089 ●	Stator resistance (Ω)	☆☆☆	P203 ●	I gain (%)	0.00
P091 ●	Serial link slave address	0	P205 ●	Sample interval (x 25 ms)	1
P092 ●	Serial link baud rate	6	P206 ●	Transducer filtering	0
P093 ●	Serial link timeout (seconds)	0	P207 ●	Integral capture range (%)	100
P094 ●	Serial link nominal system setpoint (Hz)	50.00	P208	Transducer type	0
P095 ●	USS compatibility	0	P210	Transducer reading (%)	-
P099 ●	Communication adapter type	0	P211 ●	0% setpoint	0.00
P101 ●	Operation for Europe or North America	0	P212 ●	100% setpoint	100.00
P111	Inverter power rating (kW/hp)	☆☆☆	P220	PI frequency cut-off	0
P112	Inverter type	8	P331	Analogue mode	2
P113	COMBIMASTER model	-	P332	Fine adjustment (%)	10
P121	Enable/disable RUN button	1	P723	State of digital inputs	-
P122	Enable/disable FORWARD/REVERSE button	1	P845	Motor current limit for flying start (V3.00)	50
P123	Enable/disable JOG button	1	P910 ●	Local/Remote mode	0
P124	Enable/disable Δ and ∇ buttons	1	P922	Software version	-
P125	Reverse direction inhibit	1	P923 ●	Equipment system number	0
P131	Frequency setpoint (Hz)	-	P930	Most recent fault code	-
P132	Motor current (A)	-	P931	Most recent warning type	-
P133	Motor torque (% nominal torque)	-	P944	Reset to factory default settings	0
P134	DC link voltage (V)	-	P971 ●	EEPROM storage control	1
P135	Motor RPM	-	P986	Relay Output	0
P137	Output voltage (V)	-			
P140	Most recent fault code	-			
P141	Most recent fault code -1	-			
P142	Most recent fault code -2	-			
P143	Most recent fault code -3	-			
P151 ●	Green LED function	4			



WARNING

Please refer to the Reference Manual before changing any parameters.

For Technical Support Information,
and to submit your suggestions
for improvements, see our Web Site:
<http://www.con.siemens.co.uk>



6 S E 9 9 9 6 - 0 X A 3 6
6SE9996-0XA36



H 1 7 3 1 - U 4 0 0 - D 2
G85139-H1731-U400-D2
August 1999
English

Herausgegeben vom
Bereich Automatisierungs-
und Antriebstechnik (A&D)
Geschäftsgebiet Standard Drives
Postfach 3269, D-91050 Erlangen

Siemens plc
Automation & Drives
Standard Drives Division
Siemens House
Varey Road
Congleton CW12 1PH



Order Number: 6SE9996-0XA36

Änderungen vorbehalten
Specification subject to change without prior notice