

SIEMENS

SIMATIC

ET 200B Distributed I/O Station

Manual

Preface, Contents

Part 1: User information

System Overview

1

Technical Description

2

Mechanical and Electrical
Installation

3

Configuration and
Parameterization

4

Status and Error Diagnostics

5

Part 2: Reference information

General Technical Specifications

6

Digital Modules

7

Analog Modules

8

Appendices

Type Files and GSD Files

A

Configuration Telegram

B

Parameterization Telegram

C

Configuring with
COM ET 200 V4.x

D

Analog Modules and Old Type
Files

E

Order Numbers

F

Glossary, Index

EWA 4NEB 812 6089-02c

Edition 04

Safety Guidelines

This manual contains notices which you should observe to ensure your own personal safety, as well as to protect the product and connected equipment. These notices are highlighted in the manual by a warning triangle and are marked as follows according to the level of danger:



Danger

indicates that death, severe personal injury or substantial property damage **will** result if proper precautions are not taken.



Warning

indicates that death, severe personal injury or substantial property damage **can** result if proper precautions are not taken.



Caution

indicates that minor personal injury or property damage can result if proper precautions are not taken.

Note

draws your attention to particularly important information on the product, handling the product, or to a particular part of the documentation.

Qualified Personnel

The device/system may only be set up and operated in conjunction with this manual.

Only **qualified personnel** should be allowed to install and work on this equipment. Qualified persons are defined as persons who are authorized to commission, to ground, and to tag circuits, equipment, and systems in accordance with established safety practices and standards.

Correct Usage

Note the following:



Warning

This device and its components may only be used for the applications described in the catalog or the technical description, and only in connection with devices or components from other manufacturers which have been approved or recommended by Siemens.

This product can only function correctly and safely if it is transported, stored, set up, and installed correctly, and operated and maintained as recommended.

(A)

가

Trademarks

SIMATIC® and SINEC® are registered trademarks of SIEMENS AG.

Some of the other designations used in these documents are also registered trademarks; the owner's rights may be violated if they are used by third parties for their own purposes.

Copyright © Siemens AG 1995 All rights reserved

The reproduction, transmission or use of this document or its contents is not permitted without express written authority. Offenders will be liable for damages. All rights, including rights created by patent grant or registration of a utility model or design, are reserved.

Siemens AG
Automation Group
Industrial Automation Systems
P.O. Box 4848, D-90327 Nuremberg

Disclaimer of Liability

We have checked the contents of this manual for agreement with the hardware and software described. Since deviations cannot be precluded entirely, we cannot guarantee full agreement. However, the data in this manual are reviewed regularly and any necessary corrections included in subsequent editions. Suggestions for improvement are welcomed.

Technical data subject to change.
© Siemens AG 1995

Preface

Purpose of the Manual

The information contained in this manual will allow you:

- To install, wire and start up the ET 200B distributed I/O station.
- To find module characteristics and technical specifications quickly and easily.

Contents of the Manual

The following explains the structure of the contents of the manual:

What is the ET 200B?	—————▶	Chap. 1
Which control and display elements does the ET 200B have?	—————▶	Chap. 2
How is the ET 200B installed?	—————▶	Chap. 3
How do I configure and parameterize the ET 200B?	—————▶	Chap. 4
Faults?	—————▶	Chap. 5
Technical Specifications?	—————▶	Chap. 6, 7, 8
Which type files do I need?	—————▶	Appendix A
How are configuration and parameterization telegrams structured?	—————▶	Appendix B, C

Scope of the Manual

This manual describes all the ET 200B modules which can be accessed with the **PROFIBUS-DP** bus protocol. These ET 200B modules all have order numbers starting with 6ES7 (see Section F.1).

This manual is valid for operation of the ET 200B with:

- IM 308-B master interface module and COM ET 200 V4.x
- IM 308-C master interface module and COM ET 200 WINDOWS
- S7/M7-DP master with PROFIBUS-DP interface and STEP 7
- other PROFIBUS-DP masters from Siemens and other vendors.

Electronic Manuals

You can also order the documentation for the ET 200B distributed I/O station as an electronic manual on CD-ROM.

Other Requisite Manuals

In addition to this manual, you will also need the manual for the DP master used (see Appendix F.2).

Organizational Conventions

The following organizational conventions are used in this manual to make it easier for you to find specific information:

- At the front of the manual is a complete table of contents, together with a list of all the figures and tables contained in the manual.
- The left-hand column of each page in the individual chapters has headings to help you find information more quickly.
- The Appendix is followed by a glossary containing definitions of the most important technical terms used in the manual.
- At the end of the manual is a detailed index which you can use to refer to specific sections.

Standards

The ET200B distributed I/O station is based on the PROFIBUS standard (EN 50170, Part 1) and the PROFIBUS-DP standard (EN 50170, Part 3).

Courses

Our "KO-ET 200" workshop is the ideal way to get to know the ET 200 distributed I/O system.

If you would like more information, please contact your regional Training Center or the following address:

Product Marketing for SIMATIC, SINEC and COROS
AUT 951
Frau Lades
Postfach 4848
D-90327 Nürnberg

Tel.: +49 (911) 895-3154

Fax: +49 (911) 895-5021

Queries

Please direct all technical queries to your Siemens contact partner in the office responsible for your area. You can look up the addresses in the manuals for the CPUs, for example in the "Siemens Worldwide" appendix of the manual *S7-300 Programmable Controller Hardware and Installation*, in catalogs and in CompuServe (go autforum).

You may prefer to use our hotline support; the number to dial is +49 (911) 895-7000 (fax 7001).

If you need type files or GSD files, the modem number to dial is +49 (911) 737972.

If you have any questions or comments on this manual, please complete the suggestions form and return it to us. You will find this form at the back of the manual.

Contents

1	System Overview	
1.1	What is the ET 200 Distributed I/O System?	1-2
1.2	What is the ET 200B?	1-3
1.2.1	Terminal Block	1-5
1.2.2	Electronics Block	1-6
2	Technical Description	
2.1	Design of the Terminal Block	2-2
2.2	Design of the Electronics Block	2-4
3	Mechanical and Electrical Installation	
3.1	Installing and Setting the Terminal Block	3-2
3.2	Installing the Electronics Block	3-12
3.3	Dismantling the Terminal Block and the Electronics Block	3-14
3.4	Electrical Installation	3-16
3.4.1	Grounded Configuration	3-17
3.4.2	Ungrounded Configuration	3-20
3.5	Wiring the Terminal Block	3-22
3.6	Wiring the Bus Interface	3-26
4	Configuration and Parameterization	
4.1	Configuration Options	4-2
4.2	Requirements for Configuration	4-3
4.3	Where to Find the Requisite Information?	4-5
5	Status and Error Diagnostics	
5.1	Possible Response on Startup	5-2
5.2	Status and Error Indication by LEDs	5-3
5.3	Slave Diagnostics	5-5
5.3.1	General Information on Slave Diagnostics, Operation with IM 308-C	5-6
5.3.2	General Information on Slave Diagnostics, Operation with S7/M7 DP Masters (STEP 7) or Other PROFIBUS-DP Masters	5-8
5.3.3	Structure of Slave Diagnostics	5-9
5.3.4	Structure of Station Status 1 to 3	5-11
5.3.5	Structure of the Master Station Number and the Manufacturer ID	5-13
5.3.6	Structure of Device-Related Diagnostics (Digital ET 200B)	5-14
5.3.7	Structure of ID-related Diagnostics (Analog ET 200B)	5-16
5.3.8	Structure of Device-Related Diagnostics (Analog ET 200B)	5-18

6 General Technical Specifications

7 Digital Modules

7.1	Digital Modules	7-2
7.2	Terminal Blocks	7-4
7.2.1	Terminal Block TB1/DC (6ES7 193-0CA10-0XA0)	7-5
7.2.2	Terminal Block TB1-4/DC (6ES7 193-0CA20-0XA0)	7-6
7.2.3	Terminal Block TB3/DC (6ES7 193-0CA30-0XA0)	7-7
7.2.4	Terminal Block TB2/DC (6ES7 193-0CB10-0XA0)	7-8
7.2.5	Terminal Block TB2-4/DC (6ES7 193-0CB20-0XA0)	7-9
7.2.6	Terminal Block TB4/DC (6ES7 193-0CB30-0XA0)	7-10
7.2.7	Terminal Block TB4M/DC (6ES7 193-0CE30-0XA0)	7-11
7.2.8	Terminal Block TB6/AC (6ES7 193-0CC10-0XA0)	7-12
7.2.9	Terminal Block and Bus Connector	7-13
7.3	Electronics Blocks	7-14
7.3.1	Electronics Block ET 200B-16DI (6ES7 131-0BH00-0XB0)	7-15
7.3.2	Electronics Blocks ET 200B-32DI (6ES7 131-0BL00-0XB0) and ET 200B-32DI 0.2ms (6ES7 131-0BL10-0XB0)	7-20
7.3.3	Electronics Block ET 200B-16DO (6ES7 132-0BH01-0XB0)	7-26
7.3.4	Electronics Block ET 200B-16DO/2A (6ES7 132-0BH11-0XB0)	7-32
7.3.5	Electronics Block ET 200B-32DO (6ES7 132-0BL01-0XB0)	7-38
7.3.6	Electronics block ET 200B-8RO (6ES7 132-0GF00-0XB0)	7-44
7.3.7	Electronics Block ET 200B-8DI/8DO (6ES7 133-0BH01-0XB0)	7-49
7.3.8	Electronics Block ET 200B-8DI/8DO HWA (6ES7 133-0BH10-0XB0)	7-55
7.3.9	Electronics Block ET 200B-16DI/16DO (6ES7 133 0BL00-0XB0)	7-62
7.3.10	Electronics Blocks ET 200B-24DI/8DO (6ES7 133-0BN01-0XB0) and ET 200B-24DI/8DO 0.2ms (6ES7 133-0BN11-0XB0)	7-68
7.3.11	Electronics Block ET 200B-16DI-AC (6ES7 131-0HF00-0XB0)	7-74
7.3.12	Electronics Block ET 200B-16DO-AC (6ES7 132-0HF00-0XB0)	7-79
7.3.13	Electronics Block ET 200B-16RO-AC (6ES7 132-0HH00-0XB0)	7-84
7.3.14	Electronics Block ET 200B-8DI/8RO-AC (6ES7 133-0HH00-0XB0)	7-89

8 Analog Modules

8.1	Analog Modules	8-2
8.2	Terminal Block TB8 (6ES7 193-0CD40-0XA0)	8-3
8.3	Terminal Block TB8 and Bus Connector	8-4
8.4	Electronics Block ET 200B-4/8AI (6ES7 134-0KH01-0XB0)	8-5
8.4.1	Connecting Transducers	8-7
8.4.2	Configuration Options	8-20
8.4.3	Setting the Operating Mode	8-23
8.4.4	Analog Value Representation, Operation with SIMATIC S5	8-26
8.4.5	Analog Value Representation, Operation with SIMATIC S7	8-39
8.4.6	Block Diagram, Terminal Assignment and Technical Data	8-47
8.5	Electronics Block ET 200B-4AI (6ES7 134-0HF01-0XB0)	8-51
8.5.1	Connecting Transducers	8-53
8.5.2	Configuration Options	8-61
8.5.3	Setting the Operating Mode	8-62
8.5.4	Analog Value Representation, Operation with SIMATIC S5	8-65
8.5.5	Analog Value Representation, Operation with SIMATIC S7	8-70
8.5.6	Block Diagram, Terminal Assignment and Technical Data	8-72

8.6	Electronics Block ET 200B-4AO (6ES7 135-0HF01-0XB0)	8-76
8.6.1	Connecting Loads	8-78
8.6.2	Configuration Options	8-82
8.6.3	Setting the Operating Mode	8-83
8.6.4	Analog Value Representation, Operation with SIMATIC S5	8-85
8.6.5	Analog Value Representation, Operation with SIMATIC S7	8-87
8.6.6	Block Diagram, Terminal Assignment and Technical Data	8-89
A	Type Files and GSD Files	
A.1	Type Files of the ET 200B Modules	A-2
A.2	GSD Files of the ET 200B Modules	A-4
B	Configuration Telegram	
C	Parameterization Telegram	
C.1	Structure of the Parameterization Telegram	C-2
C.2	Standard Part of the Parameterization Telegram	C-3
C.3	Parameters for Status	C-4
C.4	Parameters for Analog Input Modules	C-5
C.5	Parameters for Analog Output Module	C-10
D	Configuring with COM ET 200 V4.x	
D.1	Status and Error Indication by LEDs	D-2
D.2	Slave Diagnostics	D-3
D.2.1	General Information on Slave Diagnostics, Operation with IM 308-B	D-4
D.2.2	Structure of Slave Diagnostics	D-6
D.2.3	Structure of Device-Related Diagnostics (Analog ET 200B)	D-8
D.3	Configuration Options	D-11
D.4	Setting the Operating Mode with COM ET 200 V4.x	D-12
E	Analog Modules and Old Type Files	
E.1	Status and Error Indication by LEDs	E-2
E.2	Structure of Device-Related Diagnostics (Analog ET 200B)	E-3
E.3	Configuration Options	E-7
E.4	Parameters for Analog Modules	E-8
F	Order Numbers	
F.1	Order Numbers for ET 200B Components	F-2
F.2	Order Numbers for PROFIBUS-DP Accessories	F-4

Figures

1-1	Typical PROFIBUS-DP Configuration with SIMATIC S5/S7/M7	1-2
1-2	Components of ET 200B	1-3
2-1	The TB1/DC	2-2
2-2	The TB8	2-3
2-3	ET 200B-16DI Electronics Block	2-4
3-1	Clearances Required for Installation of the 16DI, 16DO, 8DI/8DO, 8DI/8DO HWA, 8RO and 4/8AI, 4AI, 4AO Electronics Blocks (without Shield Connecting Element)	3-2
3-2	Clearances Required for Installation of the 16DI-AC, 16DO-AC, 32DI, 16DO/2A, 32DO, 16DI/16DO, 24DI/8DO, 16RO-AC and 8DI/8RO-AC Electronics Blocks	3-3
3-3	Clearances Required for Installation of the 4/8AI, 4AI and 4AO Electronics Blocks (with Shield Connecting Element)	3-4
3-4	Hanging the Terminal Block on the Standard Sectional Rail and Setting the Coding Slide Switch	3-6
3-5	Mounting the Shield Connecting Element on the Standard Sectional Rail	3-7
3-6	Mounting the Terminal Block on the Shield Connecting Element	3-8
3-7	Changing the Setting of the Coding Plug	3-10
3-8	Engaging the Electronics Block on the Terminal Block	3-12
3-9	Dismantling the ET 200B	3-15
3-10	Both Screws Tightened in a Grounded Configuration	3-18
3-11	Grounded Configuration for 24 V DC Digital Modules of the ET 200B ...	3-18
3-12	Grounded Configuration for 120/230 V AC Digital Modules of the ET 200B	3-19
3-13	Upper Screw Removed in an Ungrounded Configuration	3-21
3-14	Ungrounded Configuration for 24 V DC Digital Modules of the ET 200B	3-21
3-15	Connecting Cables to Spring-Latch Terminals	3-23
3-16	Shield Connecting Element on Terminal Block TB8	3-25
5-1	Structure of Slave Diagnostics for Digital ET 200B	5-9
5-2	Structure of Slave Diagnostics for Analog ET 200B	5-10
5-3	Structure of the Header (Device-Related Diagnostics) for Digital ET200B (Byte 6)	5-14
5-4	Structure of Device-Related Diagnostics for Digital ET 200B (Byte 7)	5-14
5-5	Structure of the Header (ID-related Diagnostics) for Analog ET200B (Byte 6)	5-16
5-6	Structure of ID-related Diagnostics for Analog ET 200B (Bytes 7, 8)	5-16
5-7	Structure of ID-related Diagnostics for Analog ET 200B (Bytes 7, 8) in the Event of an Error in the Configuration Telegram	5-17
5-8	Structure of the Header (Device-Related Diagnostics) for Analog ET200B (Byte 9)	5-18
5-9	Structure of Device-Related Diagnostics for Analog ET 200B (Bytes 10 to 28)	5-19
7-1	Dimensional Drawing: Terminal Block TB1/DC (Screw-Type Terminal, 3-Tier)	7-5
7-2	Terminal Numbering: Terminal Block TB1/DC (Screw-Type Terminal, 3-Tier)	7-5
7-3	Dimensional Drawing: Terminal Block TB1-4/DC (Screw-Type Terminal, 4-Tier)	7-6

7-4	Terminal Numbering: Terminal Block TB1-4/DC (Screw-Type Terminal, 4-Tier)	7-6
7-5	Dimensional Drawing: Terminal Block TB3/DC (Spring-Latch Terminal)	7-7
7-6	Terminal Numbering: Terminal Block TB3/DC (Spring-Latch Terminal)	7-7
7-7	Dimensional Drawing: Terminal Block TB2/DC (Screw-Type Terminal, 3-Tier)	7-8
7-8	Terminal Numbering: Terminal Block TB2/DC (Screw-Type Terminal, 3-Tier)	7-8
7-9	Dimensional Drawing: Terminal Block TB2-4/DC (Screw-Type Terminal, 4-Tier)	7-9
7-10	Terminal Numbering: Terminal Block TB2-4/DC (Screw-Type Terminal, 4-Tier)	7-9
7-11	Dimensional Drawing: Terminal Block TB4/DC (Spring-Latch Terminal)	7-10
7-12	Terminal Numbering: Terminal Block TB4/DC (Spring-Latch Terminal)	7-10
7-13	Dimensional Drawing: Terminal Block TB4M/DC (Spring-Latch Terminal)	7-11
7-14	Terminal Numbering: Terminal Block TB4M/DC (Spring-Latch Terminal)	7-11
7-15	Dimensional Drawing: Terminal Block TB6/AC (Screw-Type Terminal, 3-Tier)	7-12
7-16	Terminal Numbering: Terminal Block TB6/AC (Screw-Type Terminal, 3-Tier)	7-12
7-17	Dimensional Drawing: Side Elevation with Bus Connector (6ES7 972-0BA10-0XA0 and 6ES7 972-0BB10-0XA0)	7-13
7-18	Dimensional Drawing: ET 200B-16DI	7-15
7-19	Connection Diagram: ET 200B-16DI	7-15
7-20	Block Diagram: ET 200B-16DI and TB1/DC or TB3/DC	7-16
7-21	Block Diagram: ET 200B-16DI and TB1-4/DC	7-17
7-22	Dimensional Drawing: ET 200B-32DI and ET 200B-32DI 0.2ms	7-20
7-23	Connection Diagram: ET 200B-32DI and ET 200B-32DI 0.2ms	7-20
7-24	Block Diagram: ET 200B-32DI or ET 200B-32DI 0.2ms and TB2/DC or TB4/DC	7-21
7-25	Block Diagram: ET 200B-32DI or ET 200B-32DI 0.2ms and TB2-4/DC	7-22
7-26	Front Elevation: ET 200B-16DO	7-26
7-27	Block Diagram: ET 200B-16DO and TB1/DC or TB3/DC	7-27
7-28	Block Diagram: ET 200B-16DO and TB1-4/DC	7-28
7-29	Front Elevation: ET 200B-16DO/2A	7-32
7-30	Block Diagram: ET 200B-16DO/2A and TB2/DC or TB4/DC	7-33
7-31	Block Diagram: ET 200B-16DO/2A and TB2-4/DC	7-34
7-32	Front Elevation: ET 200B-32DO	7-38
7-33	Block Diagram: ET 200B-32DO and TB2/DC or TB4/DC	7-39
7-34	Block Diagram: ET 200B-32DO and TB2-4/DC	7-40
7-35	Front Elevation: ET 200B-8RO	7-44
7-36	Block Diagram: ET 200B-8RO and TB1/DC or TB3/DC	7-45
7-37	Block Diagram: ET 200B-8RO and TB1-4/DC	7-46
7-38	Front Elevation: ET 200B-8DI/8DO	7-49
7-39	Block Diagram: ET 200B-8DI/8DO and TB1/DC or TB3/DC	7-50

7-40	Block Diagram: ET 200B-8DI/8DO and TB1-4/DC	7-51
7-41	Front Elevation: ET 200B-8DI/8DO HWA	7-55
7-42	Block Diagram: ET 200B-8DI/8DO HWA and TB1/DC or TB3/DC	7-56
7-43	Block Diagram: ET 200B-8DI/8DO HWA and TB1-4/DC	7-57
7-44	Front Elevation: ET 200B-16DI/16DO	7-62
7-45	Block Diagram: ET 200B-16DI/16DO and TB2/DC or TB4/DC	7-63
7-46	Block Diagram: ET 200B-16DI/16DO and TB2-4/DC	7-64
7-47	Front Elevation: ET 200B-24DI/8DO and ET 200B-24DI/8DO 0.2ms	7-68
7-48	Block Diagram: ET 200B-24DI/8DO or ET 200B-24DI/8DO 0.2ms and TB2/DC or TB4/DC	7-69
7-49	Block Diagram: ET 200B-24DI/8DO or ET 200B-24DI/8DO 0.2ms and TB2-4/DC	7-70
7-50	Front Elevation: ET 200B-16DI-AC	7-74
7-51	Block Diagram: ET 200B-16DI-AC and TB6/AC	7-75
7-52	Front Elevation: ET 200B-16DO-AC	7-79
7-53	Block Diagram: ET 200B-16DO-AC and TB6/AC	7-80
7-54	Front Elevation: ET 200B-16RO-AC	7-84
7-55	Block Diagram: ET 200B-16RO-AC and TB6/AC	7-85
7-56	Front Elevation: ET 200B-8DI/8RO-AC	7-89
7-57	Block Diagram: ET 200B-8DI/8RO-AC and TB6/AC	7-90
8-1	Dimensional Drawing: Terminal Block TB8 (Spring-Latch Terminals)	8-3
8-2	Terminal Numbering: Terminal Block TB8 (Spring-Latch Terminals)	8-3
8-3	Dimensional Drawing: Side Elevation with Bus Connectors (6ES7 972-0BA10-0XA0 and 6ES7 972-0BB10-0XA0)	8-4
8-4	Dimensional Drawing: ET 200B-4/8AI	8-5
8-5	Connection Diagram: ET 200B-4/8AI	8-6
8-6	Connection of Thermocouples with one Compensating Box (Floating- Ground Measurement)	8-11
8-7	Connection of Thermocouples with one Compensating Box per Channel (Floating-Ground Measurement)	8-12
8-8	Connection of Thermocouples with one Compensating Box (Ground-Refer- enced Measurement)	8-13
8-9	Connection of Resistance Thermometers (Pt 100) with 2-Wire Connections (Floating-Ground Measurement)	8-14
8-10	Connection of Resistance Thermometers (Pt 100) with 2-Wire Connections (Ground-Referenced Measurement)	8-15
8-11	Connection of Resistance Thermometers (Pt 100) with 4-Wire Connections (Floating-Ground Measurement)	8-16
8-12	Connection of Resistance Thermometers (Pt 100) with 4-Wire Connections (Ground-Referenced Measurement)	8-17
8-13	2-Wire Connection of Voltage Sensors to ET 200B-4/8AI (Floating-Ground Measurement)	8-18
8-14	2-Wire Connection of Voltage Sensors to ET 200B-4/8AI (Ground-Referenced Measurement)	8-19
8-15	Block Diagram: ET 200B-4/8AI and TB8	8-47
8-16	Front Elevation: ET 200B-4AI	8-51
8-17	Two-Wire Connection of Voltage Sensors to ET 200B-4AI (Floating-Ground Measurement)	8-55
8-18	Two-Wire Connection of Voltage Sensors to ET 200B-4AI (Ground-Referenced Measurement)	8-56
8-19	Two-Wire Connection of Current Sensors (Floating-Ground Measurement)	8-57

8-20	Two-Wire Connection of Current Sensors (Ground-Referenced Measurement)	8-58
8-21	Connection of 2-Wire Measuring Transducer as Current Sensor	8-59
8-22	Connection of 4-Wire Measuring Transducer as Current Sensor or Voltage Sensor	8-60
8-23	Block Diagram: ET 200B-4AI and TB8	8-72
8-24	Front Elevation: ET 200B-4AO	8-76
8-25	4-Wire Connection of Loads for Voltage Output	8-79
8-26	2-Wire Connection of Loads for Voltage Output	8-80
8-27	2-Wire Connection of Loads for Current Output	8-81
8-28	Block Diagram: ET 200B-4AO and TB8	8-89
C-1	Structure of the Parameterization Telegram for Digital ET 200B modules	C-2
C-2	Structure of the Parameterization Telegram for Analog ET 200B Modules	C-2
C-3	Standard Part of the Parameterization Telegram	C-3
C-4	Parameters for Status	C-4
C-5	Parameters for Analog Input Modules 4/8AI, 4AI	C-5
C-6	Bytes 15 and 16 for Analog Input Modules 4/8AI, 4AI	C-6
C-7	Bytes 22 and 35 for Analog Input Modules 4/8AI, 4AI	C-7
C-8	Parameters for Analog Output Module 4AO	C-10
C-9	Bytes 15 and 16 for Analog Output Module 4AO	C-11
C-10	Bytes 22 to 35 for Analog Output Module 4AO	C-12
D-1	Structure of the Header (Device-Related Diagnostics) for Analog ET200B	D-8
D-2	Structure of Device-Related Diagnostics for Analog ET 200B (Bytes 7 to 15)	D-9
E-1	Structure of the Header (Device-Related Diagnostics) for Analog ET200B	E-3
E-2	Structure of Device-Related Diagnostics for Analog ET 200B (Bytes 7 to 24)	E-4

Tables

1-1	ET 200B: Range of Applications	1-4
3-1	Assignment of the Electronics Blocks to the Coding Slide Switch	3-9
3-2	Approved Fuses for Terminal Blocks	3-11
3-3	Approved Conductor Cross-sections	3-23
3-4	Pin Assignments of the Terminal Blocks	3-24
3-5	Bus Connectors	3-26
3-6	Pin Assignment of the PROFIBUS-DP Interface	3-26
4-1	Type File Versions and Applications	4-4
5-1	LEDs on Digital ET 200B Modules and their Meanings	5-3
5-2	LEDs on Analog ET 200B Modules and their Meanings	5-4
5-3	Function Blocks for Slave Diagnostics	5-10
5-4	Structure of Station Status 1 (Byte 0)	5-11
5-5	Structure of Station Status 2 (Byte 1)	5-11
5-6	Structure of the Master Station Number (Byte 3)	5-13
5-7	Structure of the Manufacturer ID (Bytes 4, 5)	5-13
5-8	Bytes 13 to 16 for Diagnostics and Process Alarms	5-19
5-9	Possible Values for Byte 13 in Diagnostics Alarm	5-20
5-10	Bytes 17 to 28 for Diagnostics Alarm	5-21
5-11	Diagnostics Byte for an Analog Input/Analog Output Channel	5-21
7-1	ET 200B Digital Electronics Blocks	7-2
7-2	ET 200B Digital Terminal Blocks	7-3
7-3	Pin Assignment of Terminal Blocks TB1/DC; TB1-4/DC and TB3/DC for ET 200B-16DI	7-18
7-4	Pin Assignment of Terminal Blocks TB2/DC, TB2-4/DC, TB4/DC and TB4M/DC for ET 200B-32DI and ET 200B-32DI 0.2ms	7-23
7-5	Pin Assignment of Terminal Blocks TB1/DC, TB1-4/DC and TB3/DC for ET 200B-16DO	7-29
7-6	Pin Assignment of Terminal Blocks TB2/DC; TB2-4/DC, TB4/DC and TB4M/DC for ET 200B-16DO/2A	7-35
7-7	Pin Assignment of Terminal Blocks TB2/DC, TB2-4/DC, TB4/DC and TB4M/DC for ET 200B-32DO	7-41
7-8	Pin Assignment of Terminal Blocks TB1/DC; TB1-4/DC and TB3/DC for ET 200B-8RO	7-47
7-9	Pin Assignment of Terminal Blocks TB1/DC; TB1-4/DC and TB3/DC for ET 200B-8DI/8DO	7-52
7-10	Pin Assignment of Terminal Blocks TB1/DC; TB1-4/DC and TB3/DC for ET 200B-8DI/8DO HWA	7-58
7-11	Truth for Hardware Cutoff of ET 200B-8DI/8DO HWA	7-59
7-12	Pin Assignment of Terminal Blocks TB2/DC, TB2-4/DC, TB4/DC and TB4M/DC for ET 200B-16DI/16DO	7-65
7-13	Pin Assignment of Terminal Blocks TB2/DC; TB2-4/DC and TB4/DC for ET 200B-24DI/8DO and ET 200B-24DI/8DO 0.2ms	7-71
7-14	Pin Assignment of Terminal Block TB6/AC for ET 200B-16DI-AC	7-76
7-15	Pin Assignment of Terminal Block TB6/AC for ET 200B-16DO-AC	7-81
7-16	Pin Assignment of Terminal Block TB6/AC for ET 200B-16RO-AC	7-86
7-17	Pin Assignment of Terminal Block TB6/AC for ET 200B-8DI/8RO-AC ...	7-91
8-1	Analog Electronics Blocks of ET 200B	8-2
8-2	Analog Terminal Block of ET 200B	8-2
8-3	Compensating Box Type U with Current Stabilizer.	8-9
8-4	Reference Junction with Built-in Power Supply Unit	8-9

8-5	Possible Configurations for the Input Areas of ET 200B-4/8AI, with only Voltage Sensors and Thermocouples Connected	8-20
8-6	Possible IDs for Configuring the Input Areas of ET 200B-4/8AI, with only Thermal resistors and Resistors Connected	8-21
8-7	Example for Configuring the Input Areas of ET 200B-4/8AI	8-22
8-8	Assignment of Terminals to Channel Groups	8-23
8-9	Parameters for ET 200B-4/8AI (6ES7 134-0KH01-0XB0)	8-24
8-10	Representation of an Analog Input Value as a Bit Pattern (6ES7 134-0KH01-0XB0)	8-26
8-11	Description of the Bits (6ES7 134-0KH01-0XB0)	8-26
8-12	Representation of Digitized Measured Values of the ET 200B-4/8AI (Measuring Ranges: ± 80 mV, ± 250 mV, ± 500 mV and ± 1000 mV; Complement of Twos)	8-27
8-13	Representation of Digitized Measured Values of the ET 200B-4/8AI (Measuring Ranges: ± 80 mV, ± 250 mV, ± 500 mV and ± 1000 mV; Amount and Sign)	8-28
8-14	Representation of Digitized Measured Values of the ET 200B-4/8AI for Resistance Measurement (Complement of Twos)	8-29
8-15	Representation of Digitized Measured Values of the ET 200B-4/8AI for Resistance Thermometers (Complement of Twos)	8-30
8-16	Representation of Digitized Measured Values of the ET 200B-4/8AI for Ni 100 Resistance Sensors (Complement of Twos)	8-31
8-17	Representation of Digitized Measured Values of the ET 200B-4/8AI with Linearization; Type E Thermocouples (Nickel-Chrome/Copper-Nickel, to IEC 548, Part 1; Complement of Twos)	8-32
8-18	Representation of Digitized Measured Values of the ET 200B-4/8AI with Linearization: Type J Thermocouple (Iron/Copper-Nickel (Constantan), to IEC 584) (Complement of Twos)	8-33
8-19	Representation of Digitized Measured Values of the ET 200B-4/8AI with Linearization: Type K Thermocouples (Nickel-Chrome/Nickel-Aluminum, to IEC 584) (Complement of Twos)	8-34
8-20	Representation of Digitized Measured Values of the ET 200B-4/8AI with Linearization: Type L Thermocouples (Iron/Copper-Nickel (Constantan), to DIN 43710) (Complement of Twos)	8-35
8-21	Representation of Digitized Measured Values of the ET 200B-4/8AI with Linearization; Type N Thermocouples (Nickel-Chrome-Silicium/Nickel-Silicium, to IEC 548-1; Complement of Twos)	8-36
8-22	Representation of Digitized Measured Values of the ET 200B-4/8AI with Linearization; Type T Thermocouples (Copper/Copper-Nickel, to IEC 548, Part 1; Complement of Twos)	8-37
8-23	Representation of Digitized Measured Values of the ET 200B-4/8AI with Linearization; Type U Thermocouples (Copper/Copper-Nickel, to DIN 43710; Complement of Twos)	8-38
8-24	Representation of an Analog Input Value as a Bit Pattern for SIMATIC S7 and ET 200B-4/8AI	8-39
8-25	Possible Resolutions of Analog Values: ET 200B-4/8AI	8-39
8-26	Representation of Digitized Measured Values of the ET 200B-4/8AI (Measuring Ranges: ± 80 mV, ± 250 mV, ± 500 mV and ± 1000 mV)	8-40
8-27	Representation of Digitized Measured Values of the ET 200B-4/8AI for Resistance Measurement	8-41
8-28	Representation of Digitized Measured Values of the ET 200B-4/8AI	

	for Pt 100 Resistance Sensors	8-42
8-29	Representation of Digitized Measured Values of the ET 200B-4/8AI for Ni 100 Resistance Sensors	8-42
8-30	Representation of Digitized Measured Values of the ET 200B-4/8AI with Linearization; Type E Thermocouples	8-43
8-31	Representation of Digitized Measured Values of the ET 200B-4/8AI with Linearization; Type J Thermocouples	8-43
8-32	Representation of Digitized Measured Values of the ET 200B-4/8AI with Linearization; Type K Thermocouples	8-44
8-33	Representation of Digitized Measured Values of the ET 200B-4/8AI with Linearization; Type L Thermocouples	8-44
8-34	Representation of Digitized Measured Values of the ET 200B-4/8AI with Linearization; Type N Thermocouples	8-45
8-35	Representation of Digitized Measured Values of the ET 200B-4/8AI with Linearization; Type T Thermocouples	8-45
8-36	Representation of Digitized Measured Values of the ET 200B-4/8AI with Linearization; Type U Thermocouples	8-46
8-37	Terminal Assignment of the TB8 for ET 200B-4/8AI	8-48
8-38	Possible Configurations for the Input Areas of ET 200B-4AI	8-61
8-39	Assignment of Terminals to Channels	8-62
8-40	Parameters for ET 200B-4AI)	8-63
8-41	Representation of an Analog Input Value as a Bit Pattern (6ES7 134-0HF01-0XB0)	8-65
8-42	Description of the Bits (6ES7 134-0HF01-0XB0)	8-65
8-43	Representation of Digitized Measured Values of the ET 200B-4AI (Measuring Ranges: ± 1.25 V, ± 2.5 V, ± 5 V, ± 10 V; Complement of Twos)	8-66
8-44	Representation of Digitized Measured Values of the ET 200B-4AI (Measuring Ranges: ± 1.25 V, ± 2.5 V, ± 5 V, ± 10 V; Amount and Sign)	8-66
8-45	Representation of Digitized Measured Values of the ET 200B-4AI (Measuring Ranges: ± 1.25 V, ± 2.5 V, ± 5 V, ± 10 V; Binary)	8-67
8-46	Representation of Digitized Measured Values of the ET 200B-4AI (Measuring Range: ± 20 mA; Complement of Twos)	8-67
8-47	Representation of Digitized Measured Values of the ET 200B-4AI (Measuring Range: ± 20 mA; Amount and Sign)	8-68
8-49	Representation of Digitized Measured Values of the ET 200B-4AI (Measuring Range: 0 ... 20 mA)	8-69
8-50	Representation of Digitized Measured Values of the ET 200B-4AI (Measuring Range: 4 ... 20 mA)	8-69
8-51	Representation of an Analog Input Value as a Bit Pattern for SIMATIC S7 and ET 200B-4AI	8-70
8-52	Representation of Digitized Measured Values of the ET 200B-4AI (Measuring Ranges: ± 1.25 V, ± 2.5 V, ± 5 V and ± 10 V)	8-70
8-53	Representation of Digitized Measured Values of the ET 200B-4AI (Measuring Range: ± 20 mA)	8-71
8-54	Representation of Digitized Measured Values of the ET 200B-4AI (Measuring Ranges: 0 to 20 mA and 4 to 20 mA)	8-71
8-55	Terminal Assignment of the TB8 for ET 200B-4AI	8-73
8-56	Possible Configurations for the Output Areas of ET 200B-4AO	8-82
8-57	Assignment of Terminals to Channels	8-83
8-58	Parameters for ET 200B-4AO	8-84

8-59	Representation of an Analog Output Value as a Bit Pattern (6ES7 135-0HF01-0XB0)	8-85
8-60	Description of the Bits (6ES7 135-0HF01-0XB0)	8-85
8-61	Analog Output Signals of the ET 200B-4AO (Value Ranges: ± 10 V, 0 ... 10 V, ± 20 mA, 0 ... 20 mA, 4 ... 20 mA; Complement of Twos)	8-86
8-62	Representation of an Analog Output Value as a Bit Pattern for SIMATIC S7 and ET 200B-4AO	8-87
8-63	Representation of Digitized Measured Values of the ET 200B-4AO (Output Ranges: 0 to 10 V and ± 10 V)	8-87
8-64	Representation of Digitized Measured Values of the ET 200B-4AO (Output Ranges: ± 20 mA, 0 to 20 mA and 4 to 20 mA)	8-88
8-65	Terminal Assignment of the TB8 for ET 200B-4AO	8-90
A-1	Designations of Type Files for Digital Modules	A-2
A-2	Designations of Type Files for Analog Modules	A-3
A-3	Characteristics according to EN 50170, Part 3 for ET 200B-16DI, ET 200B-32DI, ET 200B-32DI 0.2ms, ET 200B-16DO, ET 200B-16DO/2A	A-5
A-4	Characteristics according to EN 50170, Part 3 for ET 200B-32DO, ET 200B-8RO, ET 200B-8DI/8DO, ET 200B-8DI/8DO HWA	A-6
A-5	Characteristics according to EN 50170, Part 3 for ET 200B-16DI/16DO, ET 200B-24DI/8DO, ET 200B-24DI/8DO 0.2ms	A-7
A-6	Characteristics according to EN 50170, Part 3 for ET 200B-16DI-AC, ET 200B-16DO-AC, ET 200B-16RO-AC, ET 200B-8DI/8RO-AC	A-8
A-7	Characteristics according to EN 50170, Part 3 for ET 200B-4/8AI, ET 200B-4AI, ET 200B-4AO	A-9
B-1	Structure of the Configuration Telegram for Digital ET 200B Modules ...	B-2
B-2	IDs for Digital ET 200B Modules	B-2
B-3	Structure of the Configuration Telegram for Analog ET 200B Modules ...	B-3
B-4	IDs for Analog ET 200B Modules	B-3
C-1	Assignment of Terminals to Channel (Groups)	C-5
C-2	Codings for the Integration Times of the 4/8AI	C-8
C-3	Codings for the Measuring Ranges of the Analog Input Modules	C-8
C-4	Assignment of Terminals to Channels	C-10
C-5	Codings for Output Ranges of the Analog Output Module	C-13
D-1	LEDs on Analog ET 200B Modules and their Meanings	D-2
D-2	Structure of Slave Diagnostics for Digital ET 200B, Operation with IM 308-B	D-6
D-3	Structure of Slave Diagnostics for Analog ET 200B, Operation with IM 308-B	D-7
D-4	Diagnostics Data, Bytes 9 to 12	D-9
D-5	Possible Values for Byte 9	D-10
D-6	Diagnostics Data, Bytes 13 to 15	D-10
D-7	IDs for ET 200B	D-11
D-8	Content and Meanings of the Bytes in the Parameterization Telegram	D-13
E-1	LEDs on Analog ET 200B Modules and their Meanings	E-2
E-2	Diagnostics Data, Bytes 9 to 12	E-4
E-3	Possible Values for Byte 9	E-5
E-4	Bytes 13 to 16 for Diagnostics Alarm	E-5
E-5	Diagnostics Byte for an Analog Input/Analog Output Channel	E-6
E-6	Possible IDs for Configuring Input and Output and Areas	E-7

E-7	Parameters for ET 200B-4/8AI (6ES7 134-0KH01-0XB0)	E-8
E-8	Parameters for ET 200B-4AI (6ES7 134-0HF01-0XB0)	E-9
E-9	Parameters for ET 200B-4AO (6ES7 135-0HF01-0XB0)	E-10
F-1	Order Numbers, Electronics Blocks for ET 200B	F-2
F-2	Order Numbers, Terminal Blocks for ET 200B	F-3
F-3	Order Numbers, Labeling Strips	F-3
F-4	Accessories for the ET 200 Distributed I/O System	F-4
F-5	Manuals for ET 200 in SIMATIC S5	F-5
F-6	Manuals for STEP 7 and SIMATIC S7	F-5

System Overview

1

In this Chapter

The System Overview gives you information on the following:

In Section	you will find	on Page
1.1	What is the ET 200 distributed I/O system?	1-2
1.2	What is ET 200B?	1-3

1.1 What is the ET 200 Distributed I/O System?

Definition

The ET 200 distributed I/O system is based on the PROFIBUS standard (EN 50170, Part 1) and the PROFIBUS-DP standard (EN 50170, Part 3).

The field bus on which the ET 200 distributed I/O system is based is a version of PROFIBUS known as PROFIBUS-DP (DP = Dezentrale Peripherie, or distributed I/O). This version is designed for minimum reaction times in communication with the distributed inputs and outputs.

The Components of ET 200

The distributed input/output system consists of active stations (DP masters) and passive stations (DP slaves) interconnected by the PROFIBUS-DP field bus.

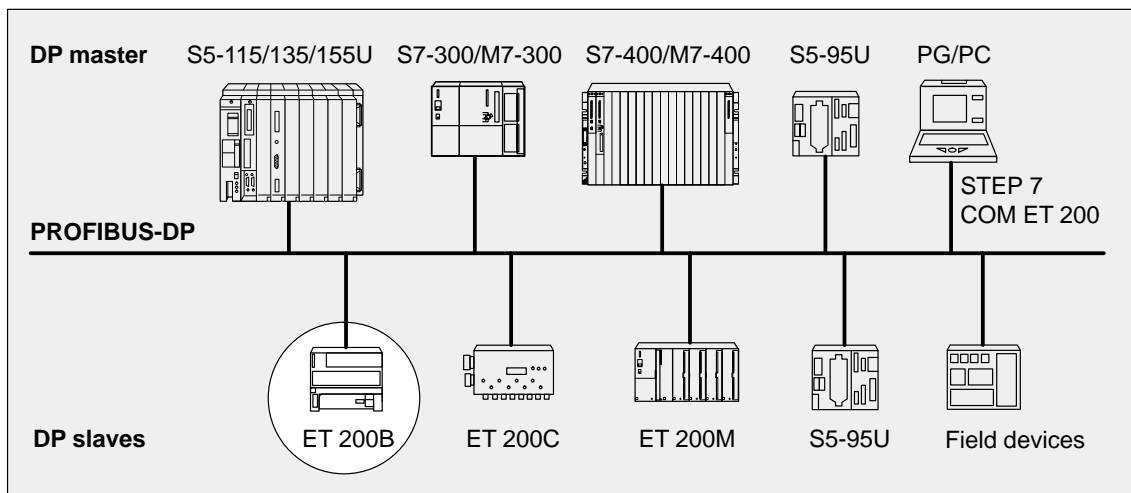

Figure 1-1 Typical PROFIBUS-DP Configuration with SIMATIC S5/S7/M7

SINEC L2-DP = PROFIBUS-DP

SINEC L2-DP is the PROFIBUS-DP from Siemens.

1.2 What is the ET 200B?

Definition

The ET 200B (B stands for "block I/O") belongs to the ET 200 distributed I/O system with the PROFIBUS-DP field bus. ET 200B is a DP slave having IP 20 protection.

The ET 200B distributed I/O station incorporates an integral port for connection to the PROFIBUS-DP bus and digital or analog inputs/outputs.

Range of Modules

The range of modules for the ET 200B includes:

- 24 V DC digital modules
- 120/230 V AC digital modules
- Analog modules

Application

Thanks to its compact and flat design, the ET 200B distributed I/O station is primarily suited to applications where space is a priority.

The ET 200B distributed I/O station can be mounted either on a standard sectional rail or directly onto the wall. Vertical and horizontal installation are both possible.

Components

The ET 200B consists of 2 parts: the terminal block and the electronics block.

The terminal block (TB) incorporates the permanent wiring and does not contain any function-related electrical components. The electronics block is attached to the terminal block. The electronics block (EB) contains the logic circuits.

The terminal block and the electronics block have matching mechanical coding elements to prevent destruction of the electronics block.

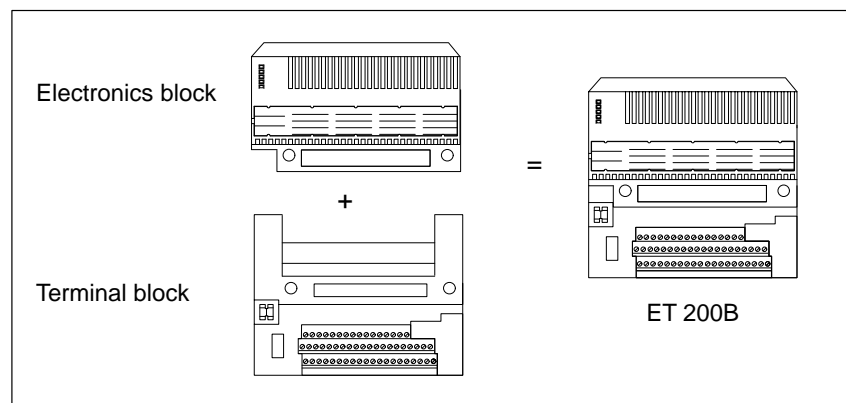

Figure 1-2 Components of ET 200B

Compatible with

All ET 200B modules can be addressed with the **PROFIBUS-DP** bus protocol.

ET 200B can be operated with the following systems:

Table 1-1 ET 200B: Range of Applications

In system	Operating with	Configurable with
SIMATIC S5	IM 308-B master interface (release 5 and higher)	COM ET 200 V4.x <ul style="list-style-type: none"> • version 4.0 and higher: digital modules • version 4.1 and higher: analog modules
	IM 308-C master interface (release 1 and higher)	COM ET 200 Windows (version 1.0 and higher)
SIMATIC S7/M7	S7/M7 DP master with integral PROFIBUS-DP interface	STEP 7 <ul style="list-style-type: none"> • version 2.0 and higher: digital modules • version 3.0 and higher: analog modules

S7 Slave

The analog modules of ET200B can be operated as S7 slaves in conjunction with SIMATIC S7/ M7 and STEP 7 (V3.0 and higher). This means that all the functions of the central S7 I/O modules are also at your disposal for the ET 200B analog modules.

The Next Sections

The next sections of this chapter contain an overview of the components of ET 200B.

In Section	you will find	on Page
1.2.1	Terminal Block	1-5
1.2.2	Electronics Block	1-6

1.2.1 Terminal Block

Definition The terminal block incorporates the permanent wiring.

Characteristics The terminal block has the following characteristics:

- The supply voltage for the electronics block (logic) can be switched on/off (except for the TB6/AC terminal block).
- The terminal block can be mounted both on standard sectional rails and on smooth surfaces, so direct wall mounting is possible.
- The PROFIBUS-DP bus is interfaced via a SINEC L2 bus connector.
- Station numbers between 00 and 99 can be set with the aid of a tool such as a screwdriver:
 - When operating with an IM 308-B master interface, station numbers 3 to 99 are permissible.
 - When operating with an IM 308-C master interface or with an S7/M7 DP master, station numbers 1 to 99 are permissible.

1.2.2 Electronics Block

Definition The electronics block contains the logic circuits and is plugged onto the terminal block.

Characteristics The electronics block has the following characteristics:

- There is galvanic isolation between the PROFIBUS-DP bus and the internal electronics.
- The block has LEDs for indicating the following:
 - Voltage supply to the logic circuits (RUN)
 - Bus fault (BF)
 - Group diagnostics: short-circuit, wire break or load voltage failure (DIA, only for electronics blocks which can be diagnosed)
 - Load voltage monitoring (L1+, L2+, L3+, L4+, only for digital electronics blocks (24 V DC) with output channels)
 - Status of the inputs or outputs (for digital electronics blocks only)
- Labeling strips are inserted in the electronics block. Fill in the labeling strips to ensure unambiguous assignment of name, channel and LED.

Technical Description

2

In this Chapter

This chapter contains information on:

In Section	you will find	on Page
2.1	Design of the Terminal Block	2-2
2.2	Design of the Electronics Block	2-4

2.1 Design of the Terminal Block

Design Principle of the Digital TBs

All digital terminal blocks are built on the same design principle explained below using the TB1/DC terminal block as a typical example:

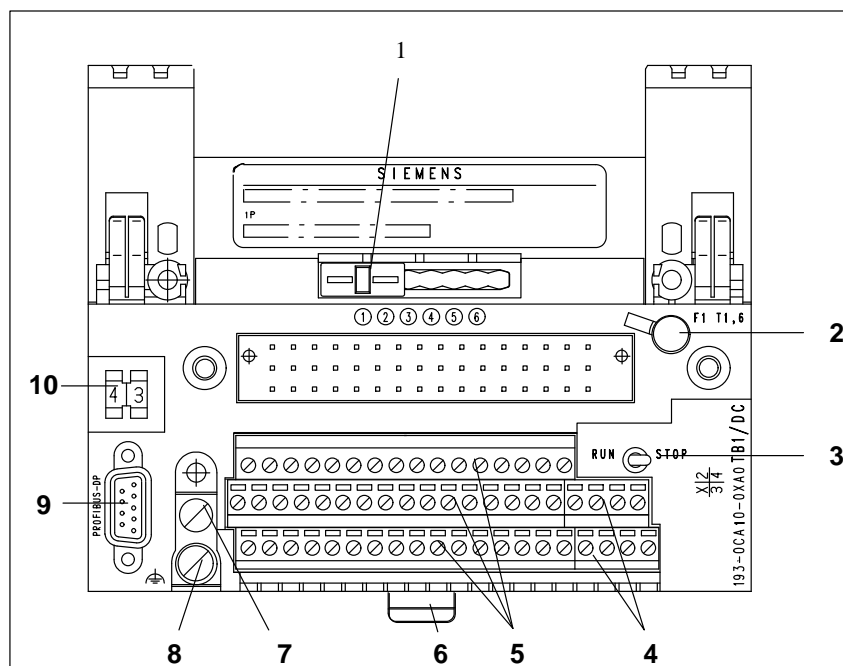

Figure 2-1 The TB1/DC

- 1 Coding slide switch
- 2 Fuse
- 3 STOP/RUN switch (not TB6/AC). The power supply for logic circuits in the electronics block can be switched on or off with the STOP/RUN switch. It can also be used to switch the ET 200B distributed I/O station on and off.
- 4 Terminals for power supplies
- 5 Terminals for inputs/outputs
- 6 Slide for removing the terminal block from the standard sectional rail
- 7 M4 screw (connects chassis to PE)
- 8 M5 screw for connecting PE
- 9 PROFIBUS-DP interface
- 10 Switch for setting the station number (the station number is valid only after operation of the STOP/RUN switch (STOP → RUN)).

Design Principle of the TB8 Analog Block

On the front of the TB8 analog terminal block, there are an additional 5 coding switches:

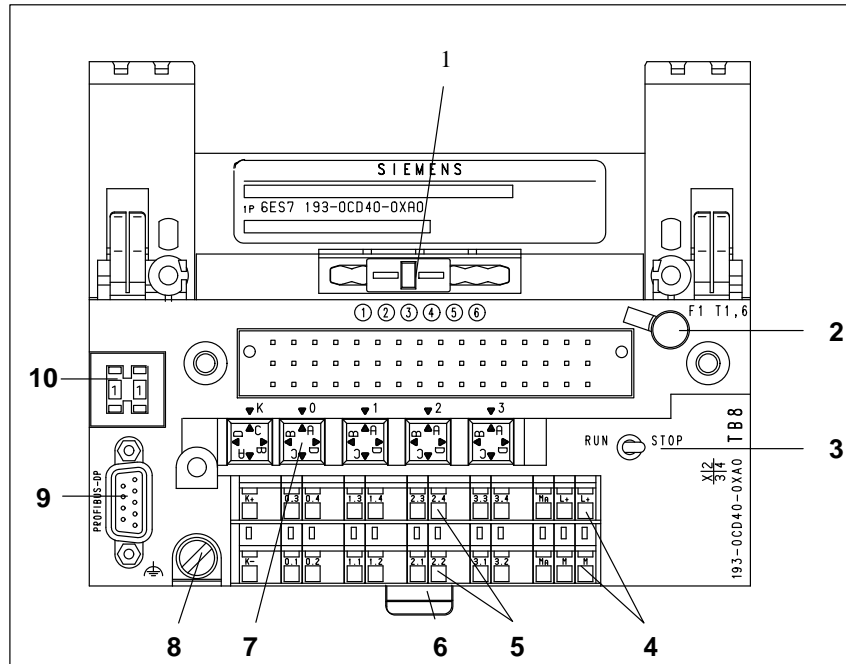

Figure 2-2 The TB8

- 1 Coding slide switch
- 2 Fuse
- 3 STOP/RUN switch. The power supply for logic circuits in the electronics block can be switched on or off with the STOP/RUN switch. It can also be used to switch the ET 200B distributed I/O station on and off.
- 4 Terminals for power supplies
- 5 Terminals for inputs/outputs
- 6 Slide for removing the terminal block from the standard sectional rail
- 7 Coding connectors. You use the coding connectors to set the wiring of the TB8 for analog value processing.
- 8 M5 screw for connecting PE
- 9 PROFIBUS-DP interface
- 10 Switch for setting the station number (the station number is valid only after operation of the STOP/RUN switch (STOP → RUN)).

2.2 Design of the Electronics Block

Design Principle

All types of electronics block are built on the same design principle which is explained below using the ET 200B-16DI electronics block as a typical example:

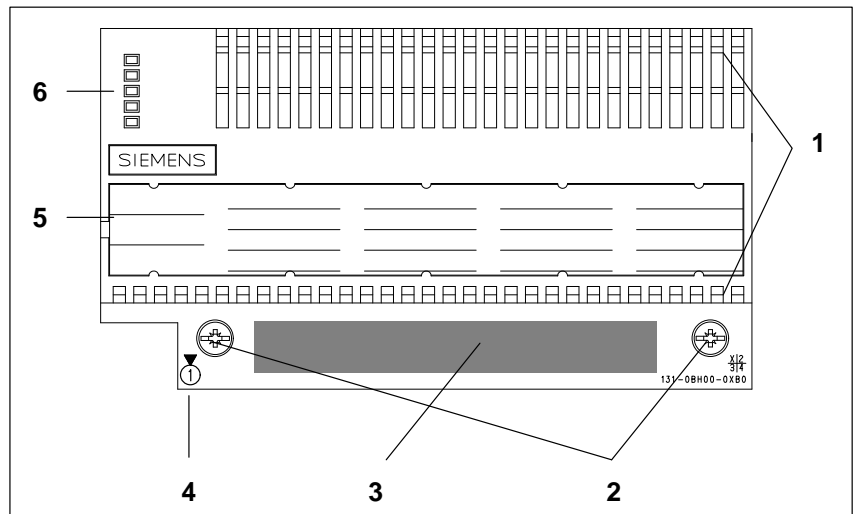

Figure 2-3 ET 200B-16DI Electronics Block

- 1 Ventilation slots
- 2 Screws for mounting the electronics block on the terminal block
- 3 Printed schematic diagram
- 4 Indication of the coding slide switch setting on the top of the terminal block
- 5 Labeling strip; for indicating the status of the inputs or outputs in the case of digital electronics blocks with LEDs
- 6 LEDs for
 - Voltage supply to the logic circuits (RUN)
 - Bus fault (BF)
 - Group diagnostics; short-circuit, wire break or load voltage failure (DIA, only for electronics blocks which can be diagnosed)
 - Load voltage monitor (L1+, L2+, L3+, L4+, depending on the electronics block: see Section 5.2)

Coding

The electronics blocks are coded by the manufacturer.

Some types of electronics blocks have a recess at the bottom. This recess ensures that the terminal block is assigned safely to the correct electronics block.

Mechanical and Electrical Installation

3

In the Chapter

This chapter contains information on:

In Section	you will find	on Page
3.1	Installing and Setting the Terminal Block	3-2
3.2	Installing the Electronics Block	3-12
3.3	Dismantling the Terminal Block and Electronics Block	3-14
3.4	Electrical Installation	3-16
3.5	Wiring the Terminal Block	3-22
3.6	Wiring the Bus Interface	3-26

Technical Data

You will find a detailed description of the technical data of the ET 200B modules in Sections 6, 7 and 8.

3.1 Installing and Setting the Terminal Block

Two Methods

You can install the terminal block either

- on a standard sectional rail (35 × 15 mm or 35 × 7.5 mm to DIN EN 50022)

or

- on smooth surfaces, i.e. direct wall mounting (for dimensions of the mounting holes see Dimensional Drawings in Sections 7 and 8).

Small Electronics Block, Digital

Figure 3-1 shows the clearances required for installation of the 16DI, 16DO, 8DI/8DO, 8DI/8DO HWA, 8RO and 4/8AI, 4AI, 4AO electronics blocks (without shield connecting element):

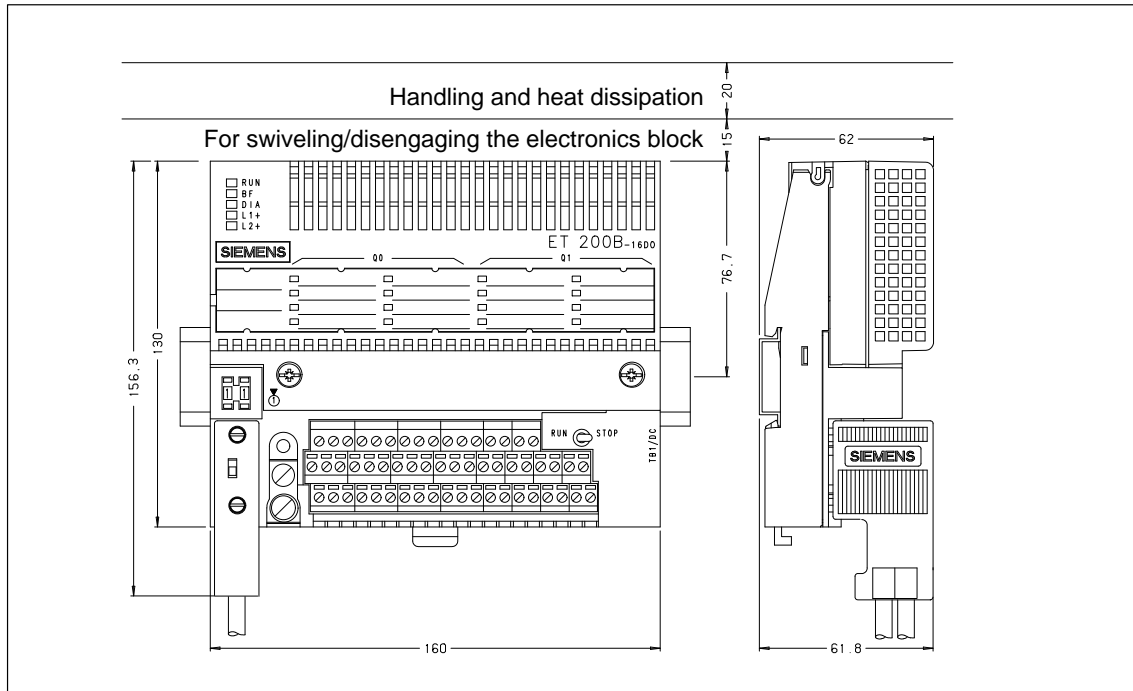

Figure 3-1 Clearances Required for Installation of the 16DI, 16DO, 8DI/8DO, 8DI/8DO HWA, 8RO and 4/8AI, 4AI, 4AO Electronics Blocks (without Shield Connecting Element)

Large Electronics Block

Figure 3-2 shows the clearances required for installation of the 16DI-AC, 16DO-AC, 32DI, 16DO/2A, 32DO, 16DI/16DO, 24DI/8DO, 16RO-AC and 8DI/8RO-AC electronics blocks:

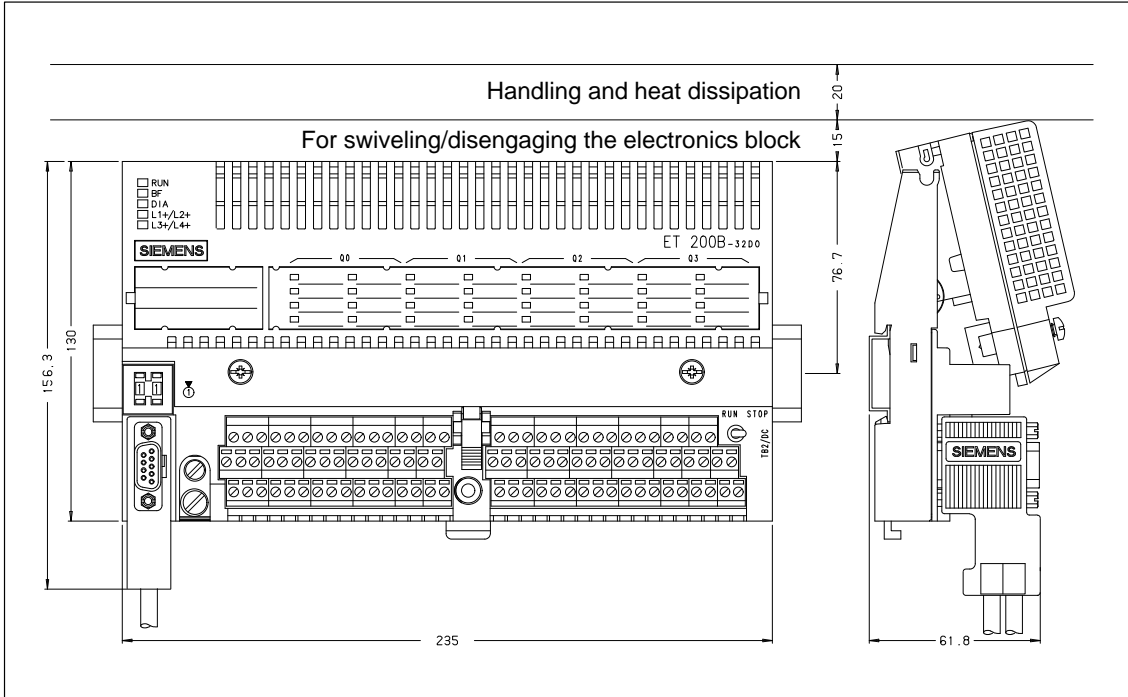

Figure 3-2 Clearances Required for Installation of the 16DI-AC, 16DO-AC, 32DI, 16DO/2A, 32DO, 16DI/16DO, 24DI/8DO, 16RO-AC and 8DI/8RO-AC Electronics Blocks

Small Electronics Block, Analog

Figure 3-3 shows the clearances required for installation of the 4/8AI, 4AI, 4AO electronics blocks (with shield connecting element):

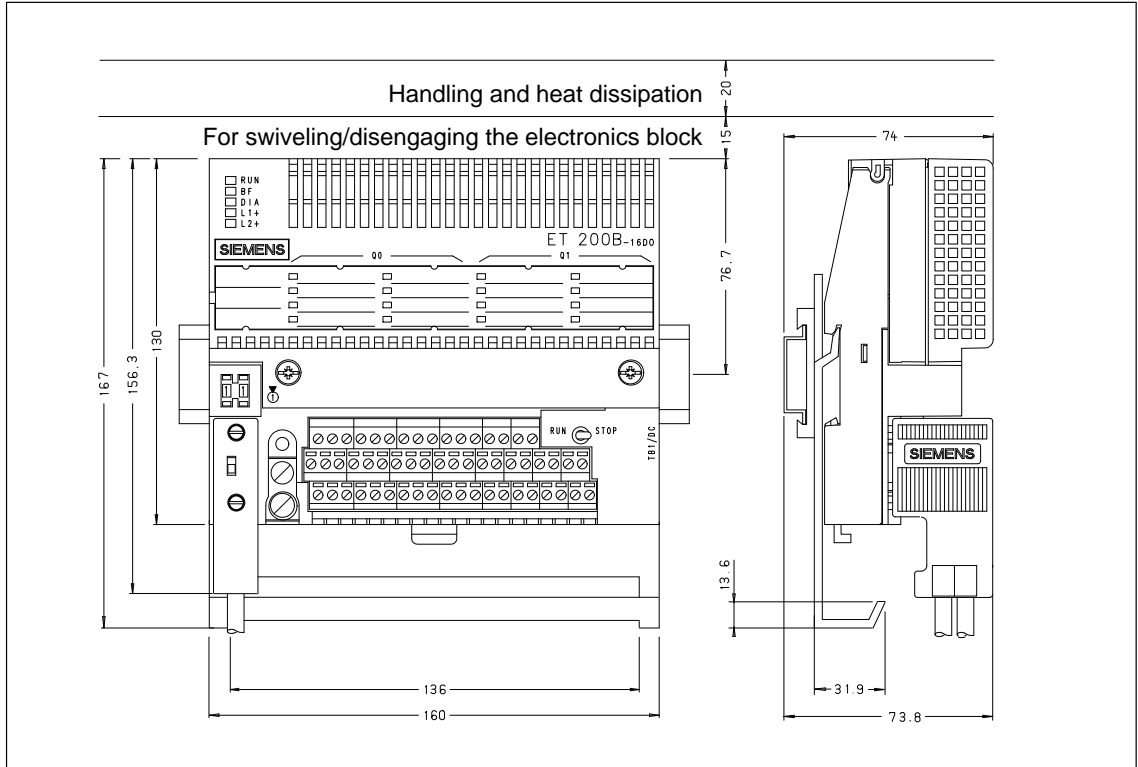

Figure 3-3 Clearances Required for Installation of the 4/8AI, 4AI and 4AO Electronics Blocks (with Shield Connecting Element)

Shield Connecting Element for TB8

In the case of analog value processing, we recommend that the cable shielding of the signal lines be connected directly at terminal block TB8.

For this application, you can hang the TB8 onto a shield connecting element after first mounting the shield connecting element on a standard sectional rail (35×15 or 35×7.5 mm to DIN EN 50022) or a smooth surface.

To secure the shield braiding, install metal terminal elements on the shield connecting element.

You can order the shield connecting element and the terminal elements under the following numbers:

- Shield connecting element → Order No. 6ES7 193-0CD40-7XA0
- Terminal elements (set of two):
 - Single version → Order No. 6ES7 390-5BA00-0AA0
(one shield cable per terminal element with a diameter of 3 to 8 mm to be clamped)
 - Double version → Order No. 6ES7 390-5AB00-0AA0
(two shield cables per terminal element with a diameter of 2 to 6 mm to be clamped)

Note

If you mount the TB8 with shield connecting element on a standard sectional rail, you must install the ET 200B horizontally.

**Mounting on a
Standard Sectional
Rail**

To mount the terminal block on a standard sectional rail...

1. Hang the terminal block on the standard sectional rail (1) and
2. Swing it back until the slide on the module snaps into place (2).

Note:

The meanings of the coding switch settings are explained in Table 3-1.

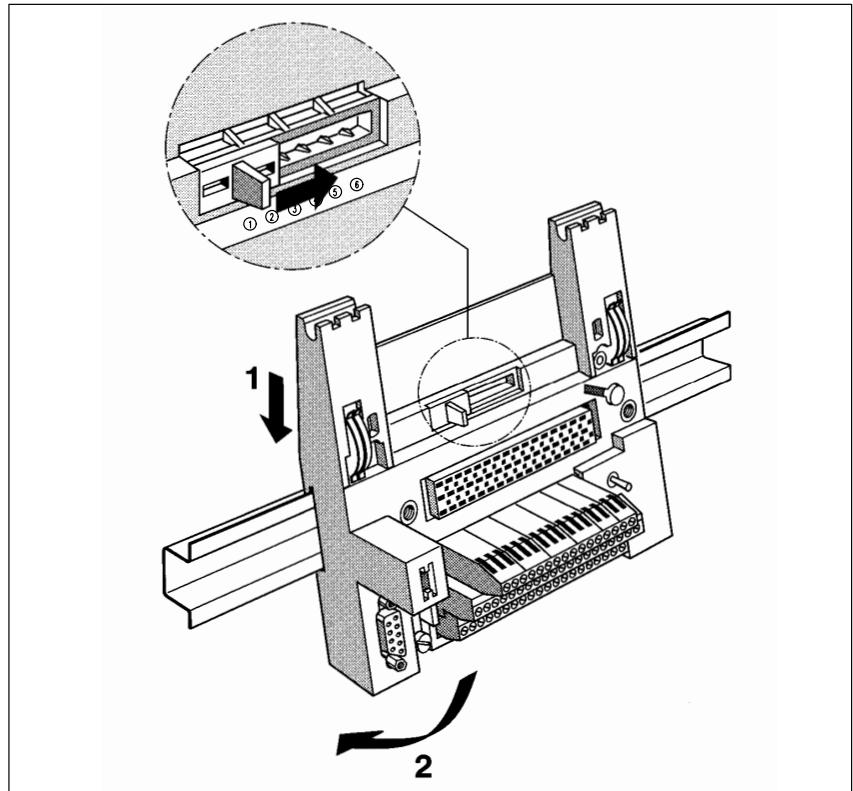
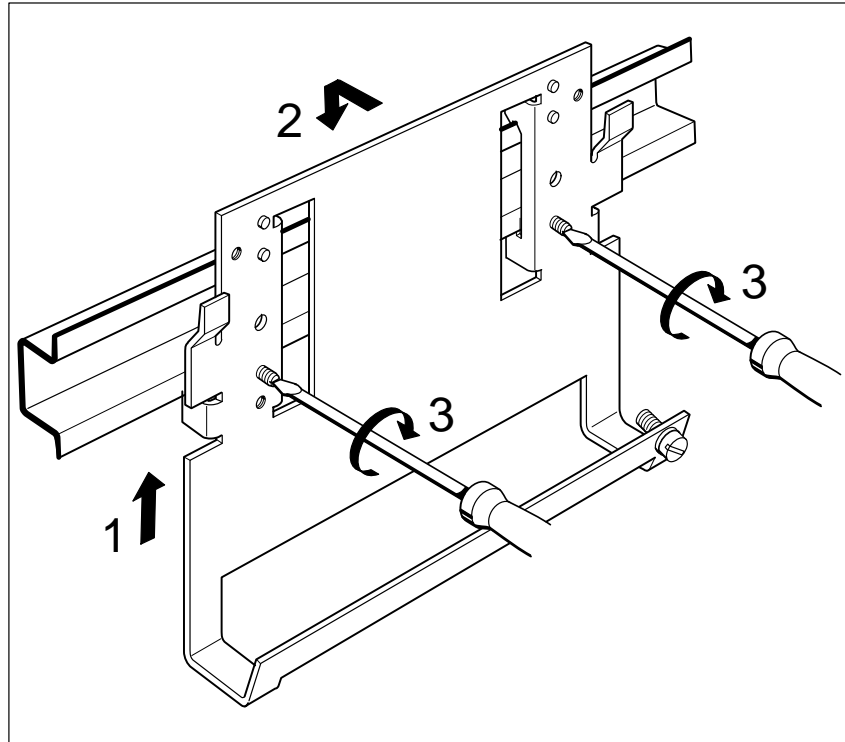

Figure 3-4 Hanging the Terminal Block on the Standard Sectional Rail and Setting the Coding Slide Switch

**Mounting the
Shield Connecting
Element on a Stan-
dard Sectional Rail**

To mount the shield connecting element on a standard sectional rail...

1. Hang the shield connecting element on the standard sectional rail from below (1) and swing it back (2).
2. Secure the shield connecting element on the standard sectional rail by tightening the screws (3).



3

Figure 3-5 Mounting the Shield Connecting Element on the Standard Sectional Rail

Mounting the Terminal Block on the Shield Connecting Element

To mount the terminal block on the shield connecting element ...

1. Engage the terminal block in the brackets of the terminal connecting element (1).
2. Tighten the screws to secure the terminal block to the shield connecting element (2).

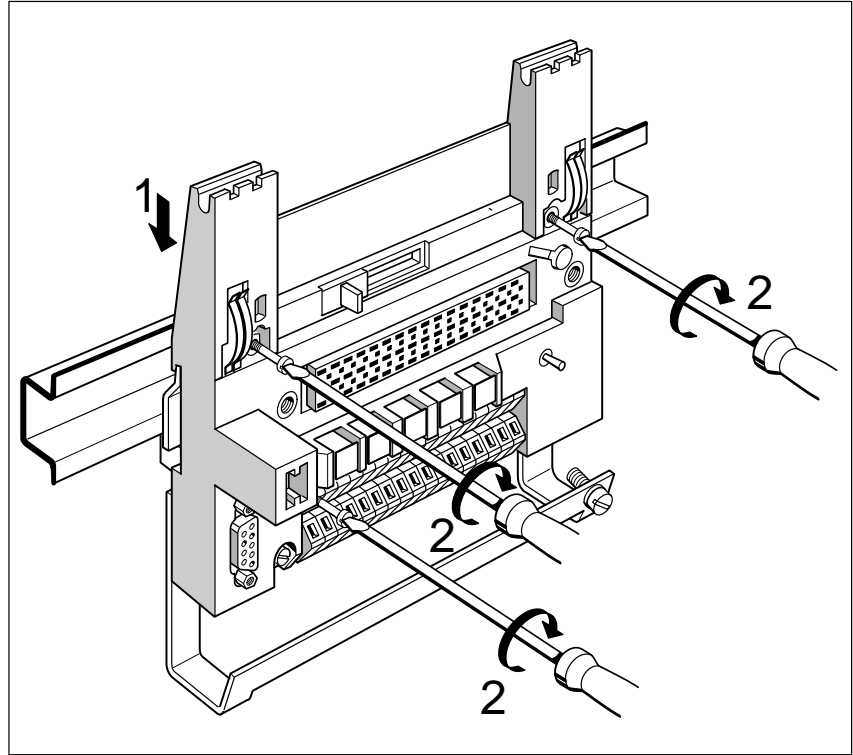

Figure 3-6 Mounting the Terminal Block on the Shield Connecting Element

Setting the Coding Slide Switch

In order to prevent the wrong electronics block being plugged in, the terminal block has a coding slide switch (see Section 2.1, Figure 2-1, **1**).

The coding switch can be engaged in 6 settings. Each setting is assigned to a module class of the ET 200B distributed I/O station:

Table 3-1 Assignment of the Electronics Blocks to the Coding Slide Switch

Setting	Module Class
1	24 V digital modules
2	24 V special modules
3	Analog modules
4	Reserved
5	Reserved
6	230 V digital modules

Setting the Station Number

Any station number from 00 to 99 can be set with the aid of a tool such as a screwdriver (see Section 2.1, Figure 2-1, **10**):

- Station numbers 3 to 99 are permissible when operating with the IM308-B master interface.
- Station numbers 1 to 99 are permissible when operating with the IM 308-C master interface or with the S7/M7 DP master.

The station number becomes valid only after a STOP/RUN transition of the ET 200B slave station.

Setting the Coding Plug

The coding plus of the TB8 provide the means of setting the defaults for analog value measurement and analog value output for each channel in the case of analog modules (see Section 2-1, Figure 2-2, **7**).

The coding plugs enable you to set the input or output circuitry of the TB8 to suit the measured value sensor or load connected and the desired measuring or output method.

The possible settings for the coding plugs are: "A", "B", "C" and "D".

The relationships between the various settings of the coding plugs and the measurement/output method and the measured value sensors and loads are detailed in the sections dealing with the individual electronics blocks (see Sections 8.4 through 8.6). The procedure for changing the settings of the coding plugs is described below.

Changing the Coding Plug Setting

The procedure for changing the setting of a coding plug is as follows:

1. Pull the coding plug above the channel group from its socket in the TB8 (1).

Tip:

It is easiest to reset the coding plugs before installing the electronics block.

2. Turn the coding plug to the appropriate position (2) and reinsert the coding plug in its socket (3).

Correct setting:

The pointer "Δ" beside the letter "A", "B", "C" or "D" must point toward the electronics block.

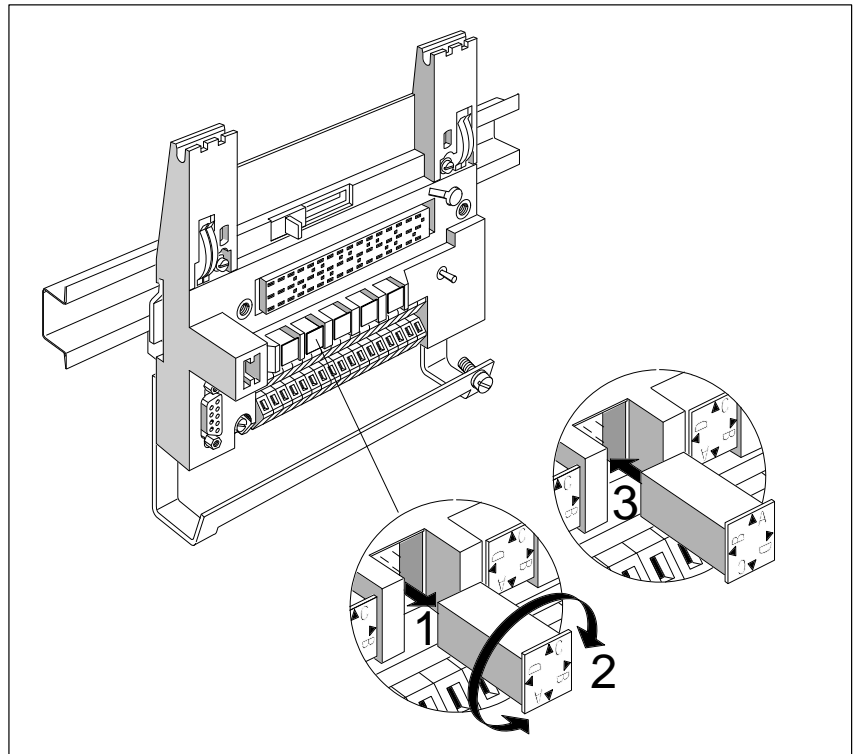

Figure 3-7 Changing the Setting of the Coding Plug

Terminal Block Fuses

The fuse (F1) in the terminal block protects against:

- short-circuit in the sensor supply
- reversed polarity of the voltage supply to the internal logic
- voltage spikes in the voltage supply to the internal logic

If the fuse trips the module's internal logic is deenergized.

Changing the Fuse

Proceed as follows when changing the fuse:

1. Switch the STOP/RUN switch to the "STOP" position.
2. Pull the electronics block off the terminal block.
3. Pry the fuse out of its base using a screwdriver.
4. Insert the new fuse.
5. Reinstall the electronics block on the terminal block.
6. Switch the RUN/STOP switch to "RUN".

Note

The TB6/AC terminal block has no STOP/RUN switch. Make sure that the external power supply is switched off before removing the electronics block and changing the fuse.

Approved Fuses

Install only the fuses listed in Table 3-2. The fuses can be ordered in packs of ten.

Table 3-2 Approved Fuses for Terminal Blocks

Terminal Block	Fuse	Order No. (pack of 10)
TB6/AC	Miniature fuse TR5-T 1.0; 250 V AC	6ES7 193-0DC00-0XA0
TB1/DC	Miniature fuse TR5-T 1.6; 250 V	6ES7 193-0DA00-0XA0
TB1-4/DC	Miniature fuse TR5-T 1.6; 250 V	
TB3/DC	Miniature fuse TR5-T 1.6; 250 V	
TB8-analog	Miniature fuse TR5-T 1.6; 250 V	
TB2/DC	Miniature fuse TR5-T 2.5; 250 V	6ES7 193-0DB00-0XA0
TB2-4/DC	Miniature fuse TR5-T 2.5; 250 V	
TB4/DC	Miniature fuse TR5-T 2.5; 250 V	
TB4M/DC	Miniature fuse TR5-T 2.5; 250 V	

3.2 Installing the Electronics Block

Engaging the Electronics Block on the Terminal Block

After coding the terminal block via the coding slide switch, you can engage the electronics block on the terminal block:



Warning

Avoid electrical destruction of the electronics block.

Always set the STOP/RUN switch of the terminal block to the “STOP” position before engaging the electronics block on the terminal block!

The TB6/DC terminal block has no STOP/RUN switch. Always switch off the external power supply before attempting to engage an electronics block (120/230 V AC) onto the TB6/DC.

1. Engage the electronics block on the terminal block (1).
2. Press the electronics block onto the terminal block (2).
3. Secure the electronics block by tightening the screws (3).

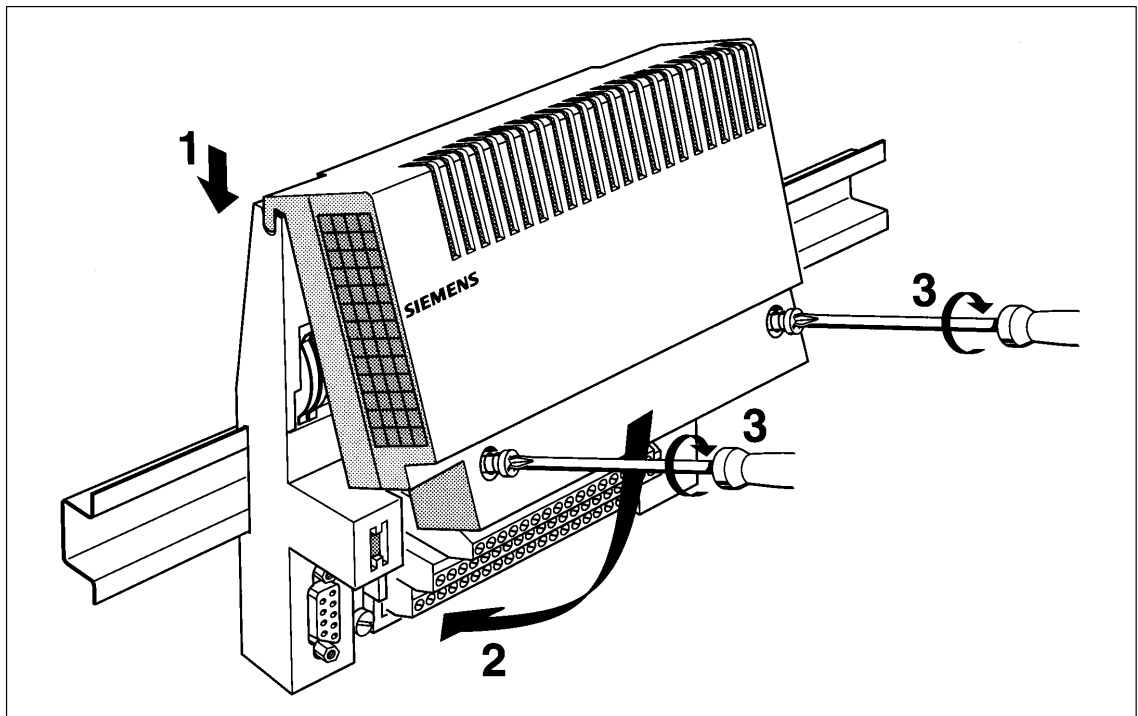

Figure 3-8 Engaging the Electronics Block on the Terminal Block

Labeling the Electronics Block

A labeling strip is inserted in the electronics block.

Individual DIN A4 sheets consisting of several labeling strips can be ordered separately. Please refer to Appendix F for order numbers.

Versions

- For electronics blocks with 16DI, 16DO, 8DI/8DO, 8DI/8DO HWA, 8RO, 4/8AI, 4AI, 4AO:

10 labeling strips on one DIN A4 sheet

- For electronics blocks with 16DI-AC, 16DO-AC, 32DI, 16DO/2A, 32DO, 16DI/16DO, 24DI/8DO, 16RO-AC, 8DI/8RO-AC:

7 large labeling strips and 9 small labeling strips on one DIN A4 sheet.

3.3 Dismantling the Terminal Block and the Electronics Block

Dismantling (from the Standard Sectional Rail)

Proceed according to the following steps:

1. Remove the electronics block in the reverse sequence to that described in Figure 3-8.



Warning

Avoid electrical destruction of the electronics block.

Always set the STOP/RUN switch of the terminal block to the “STOP” position before disengaging the electronics block from the terminal block or installing a replacement electronics block!

The TB6/DC terminal block has no STOP/RUN switch. Always switch off the external power supply before attempting to disengage an electronics block (120/230 V AC) from the TB6/DC or installing a replacement electronics block.

2. Press the slide (1) on the bottom of the terminal block down using a screwdriver and
3. Swing the terminal block out of the standard sectional rail (2).

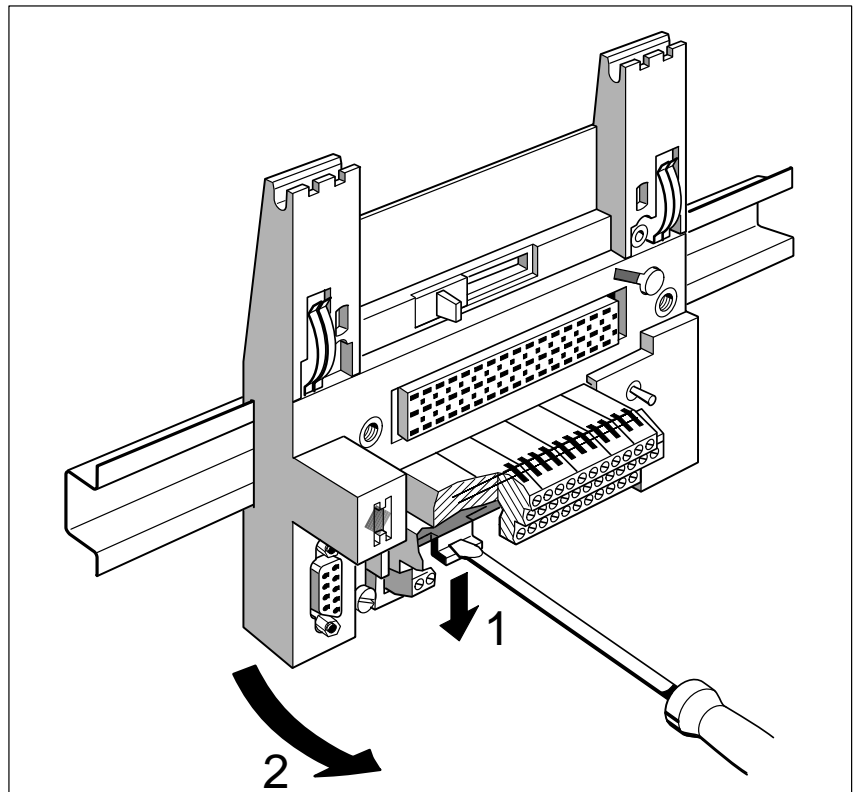

Figure 3-9 Dismantling the ET 200B

**Dismantling
(from the Shield
Connecting Ele-
ment)**



Proceed according to the following steps:

1. Remove the electronics block in the reverse sequence to that described in Figure 3-8.

Warning

Avoid electrical destruction of the electronics block.

Always set the STOP/RUN switch of the terminal block to the “STOP” position before disengaging the electronics block from the terminal block or installing a replacement electronics block!

The TB6/DC terminal block has no STOP/RUN switch. Always switch off the external power supply before attempting to disengage an electronics block (120/230 V AC) from the TB6/DC or installing a replacement electronics block.

-
2. Remove the terminal block and the shield connecting element in the reverse sequence to that described in Figures 3-5 and 3-6.

3.4 Electrical Installation

Introduction The ET 200B distributed I/O station allows both **grounded** and **ungrounded** configurations.

Next Sections The following two sections explain the configuration rules and give circuit examples for

In Section	you will find	on Page
3.4.1	Grounded Configuration	3-17
3.4.2	Ungrounded Configuration	3-20

The numbers in the text cross-reference the components shown in the figures.

3.4.1 Grounded Configuration

Definition In a grounded configuration, the reference potential of the ET 200B logic circuits and the protective ground conductor (PE) are galvanically interconnected.

Rules You must note the following points for a grounded configuration:

- You must provide a main switch **(1)** in accordance with DIN VDE 0100 for the ET 200B modules, the signal sensors and the actuators.
- If the spur lines are a maximum of 3 m long and are ground-fault-resistant and short-circuit-proof, the supply connection for the ET 200B and the load circuit requires no additional fuse **(2)**.
- Use a Siemens load power supply unit **(3)** in the 6EV1 series (**Catalog ET 1**) for supplying the 24 V DC to the ET 200B.

If you connect another load power supply unit (24 V DC), please note that the voltage must be in the range 20 to 30 V (including ripple). The load power supply unit must generate a functional low voltage with safe electrical isolation in accordance with DIN VDE 0106. In the case of non-stabilized load power supply units, you require a back-up capacitor (rating 200 μ F per 1 A load current).

- Provide a detachable connection to the protective ground conductor **(4)** in the secondary circuit of the load power supply unit (M terminal).
- A fuse **(5)** is required for fusing the supply voltage.
- For both grounded and ungrounded configurations, the PE terminal  of the ET 200B must have a low-impedance connection to the protective ground conductor or the cabinet ground (machine parts) **(6)**.
- Use a minimum cross-section of 4 mm² and a maximum of 10 mm² for equipotential bonding and ground connections.
- All machine parts must be grounded.
- The PROFIBUS-DP interface of terminal blocks release 2 and later is ungrounded.

Connecting the Reference Potential of the Logic Circuits to PE

For a grounded configuration, you must also do the following at the digital terminal blocks:

1. Connect the PE terminal to the lower screw.
2. Tighten the upper screw. The upper screw connects the ground potential to PE.

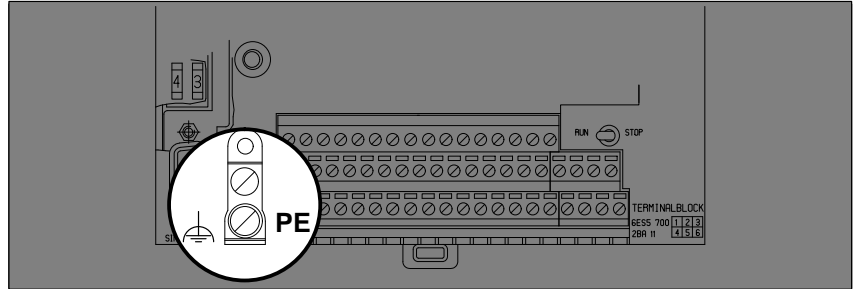

Figure 3-10 Both Screws Tightened in a Grounded Configuration

Electrical Configuration

The following figure shows the grounded configuration for 24 V DC digital modules of the ET 200B:

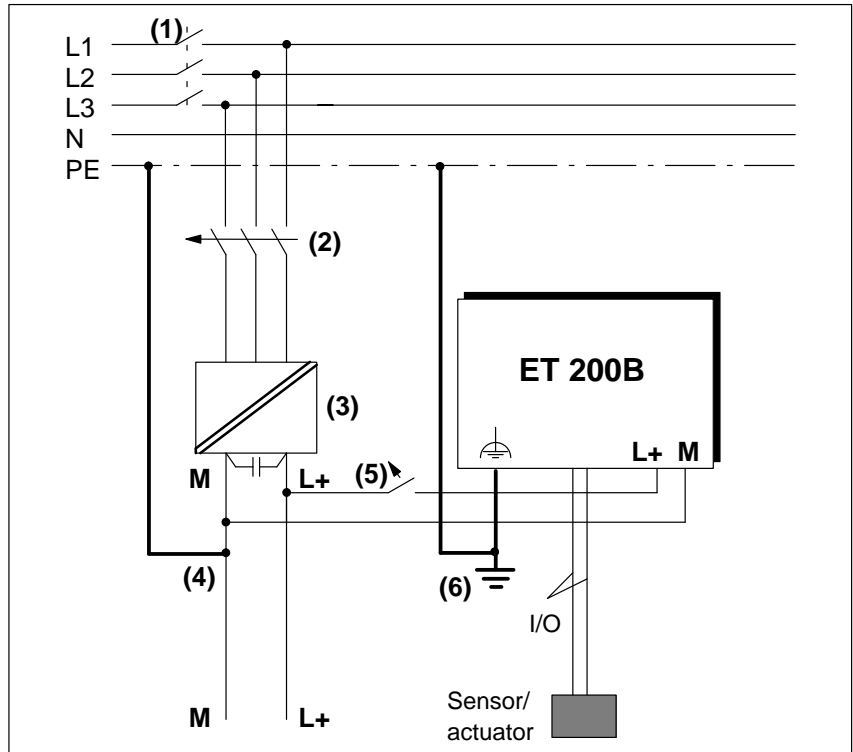

Figure 3-11 Grounded Configuration for 24 V DC Digital Modules of the ET 200B

Electrical Configuration

The following figure shows the grounded configuration for 120/230 V AC digital modules of the ET 200B:

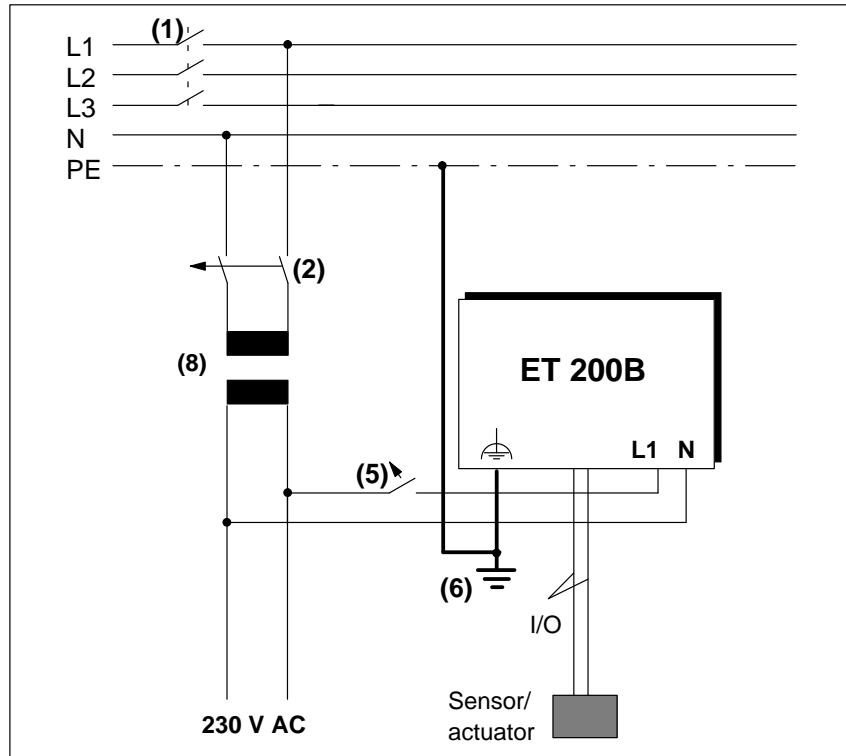



Figure 3-12 Grounded Configuration for 120/230 V AC Digital Modules of the ET 200B

3.4.2 Ungrounded Configuration

Definition In an ungrounded configuration, there is no galvanic connection between the reference potential of the ET 200B logic circuits and the protective ground conductor (PE).

- Rules** You must note the following points for an ungrounded configuration:
- You must provide a main switch (1) in accordance with DIN VDE 0100 for the ET 200B modules, the signal sensors and the actuators.
 - If the spur lines are a maximum of 3 m long and are ground-fault-resistant and short-circuit-proof, the supply connection for the ET 200B and the load circuit requires no additional fuse (2).
 - Use a Siemens load power supply unit (3) in the 6EV1 series (**Catalog ET 1**) for supplying the 24 V DC to the ET 200B.
If you connect another load power supply unit (24 V DC), please note that the voltage must be in the range 20 to 30 V (including ripple). The load power supply unit must generate a functional low voltage with safe electrical isolation in accordance with DIN VDE 0106. In the case of non-stabilized load power supply units, you require a back-up capacitor (rating 200 µF per 1 A load current).
 - A fuse (5) is required for fusing the supply voltage.
 - For both grounded and ungrounded configurations, the PE terminal  of the ET 200B must have a low-impedance connection to the protective ground conductor or the cabinet ground (machine parts) (core cross-section of PE min. 4 mm² and max. 10 mm²) (6).
 - Provide an insulation monitoring circuit against ground with voltage limitation in accordance with the regulations applying to the system, for example DIN VDE 0160 (7).
 - The PROFIBUS-DP interface of terminal blocks release 2 and later is ungrounded.



Warning

The ungrounded configuration can be canceled out by grounded machine parts and grounded electrical equipment.

Example: A grounded sensor or a grounded actuator connects the PE to the reference potential (M terminal) of the controller.

Disconnecting the Reference Potential of the Logic Circuits from PE

For an ungrounded configuration, you must also do the following at the digital terminal blocks:

1. Connect the PE terminal to the lower screw.
2. Remove the upper screw for an ungrounded configuration.

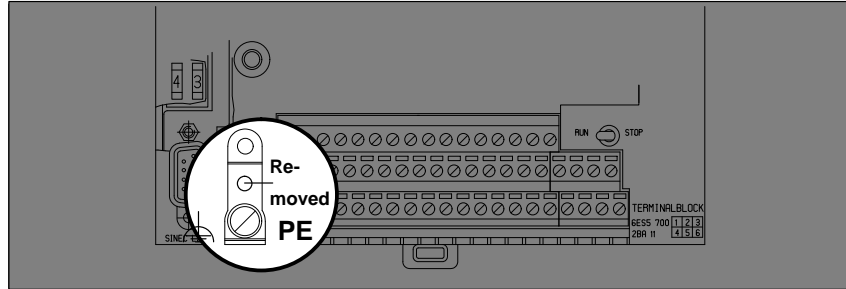

Figure 3-13 Upper Screw Removed in an Ungrounded Configuration

Electrical Configuration

Figure 3-14 shows the ungrounded configuration for 24 V DC digital modules of the ET 200B:

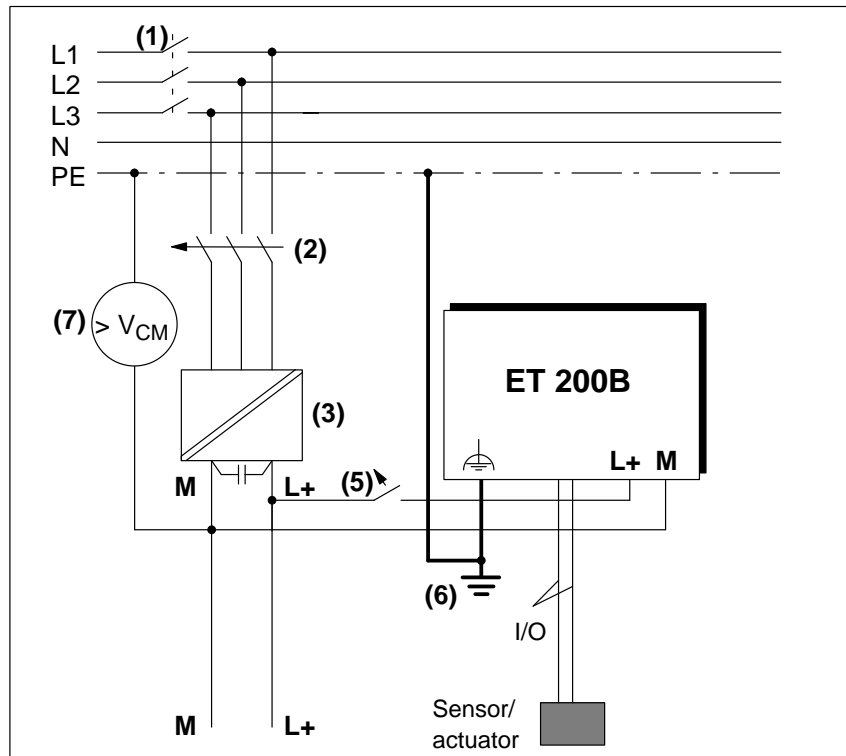

Figure 3-14 Ungrounded Configuration for 24 V DC Digital Modules of the ET 200B

3.5 Wiring the Terminal Block

Introduction

Connect the following to the terminal block:

- Supply voltage for internal logic circuits
- Sensor supply for input channels
- Load voltage supply for output channels
- Sensors/loads

Wiring

The wiring of the terminal block is dependent on the electronics block used. A distinction is made between **floating** and **non-floating** electronics blocks.

Floating Electronics Block

In a floating electronics block

- **either** the circuit for the internal electronics and the load circuit are galvanically isolated from each other:

All 120/230 V AC electronics blocks and floating 24 V DC electronics blocks belong to this category.

- **or** the voltage supply of the internal logic and the analog circuits are galvanically isolated from each other:

All analog electronics blocks belong to this category.

Note

You can use floating electronics blocks regardless of whether the reference potential of the supply voltage for the internal logic circuits is grounded or not.

Non-Floating Electronics Blocks

In non-floating electronics blocks, the internal logic circuits and the load current circuit share a common reference potential (M ground).

Non-floating electronics blocks include: non-floating 24 V DC electronics blocks.

Conductor Cross-sections

The approved conductor cross-sections for all voltage-supply and signal lines are as follows:

Table 3-3 Approved Conductor Cross-sections

Line	Conductor Ferrules	Conductor Cross-section
Supply-voltage and signal lines	with ferrules	max. 1.5 mm ²
	w/o ferrules	max. 2.5 mm ² (min. 0.08 mm ² for TB3, TB4, TB4M, TB8 and min. 0.14 mm ² for TB1, TB1-4, TB2, TB2-4)
Protective earth (PE) to terminal block*	with ferrule	max. 2.5 mm ²

* for TB1-4/DC or TB2-4/DC only

Connections

Some terminal blocks are fitted with screw terminals while others have spring-latch terminals (see Figure 3-15) for securing the cable conductors.

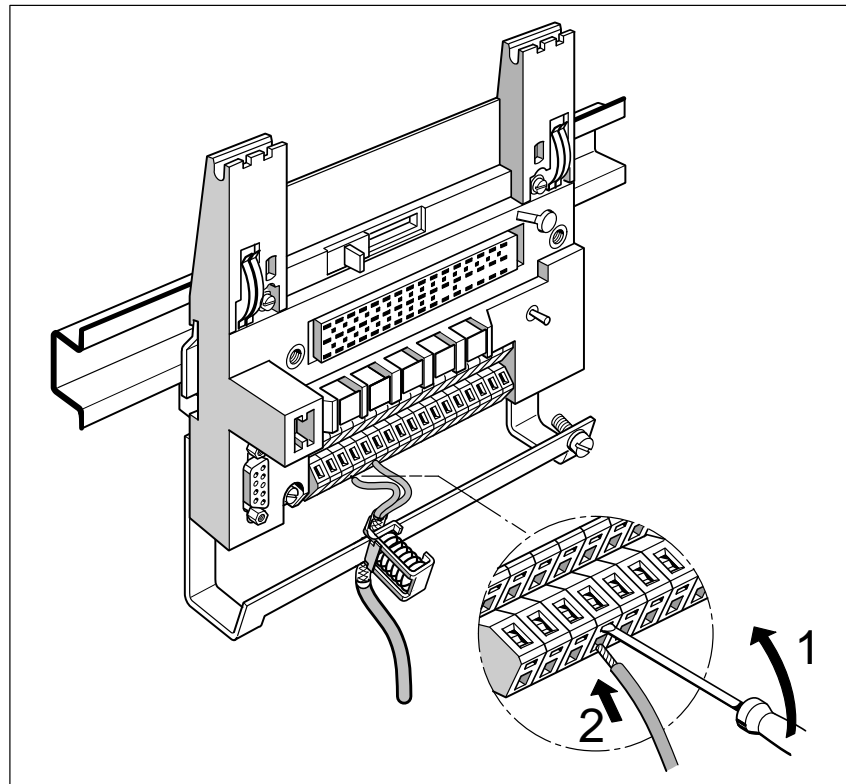

Figure 3-15 Connecting Cables to Spring-Latch Terminals

Pin Assignments

In Chapter 7 “Range of Modules”, you will find the pin assignments of each electronics block. The following table will help you.

Table 3-4 Pin Assignments of the Terminal Blocks

Assignment of ...	For Electronics Block ...	See ...
TB1/DC, TB1-4/DC and TB3/DC	ET 200B-16DI	Table 7-3
	ET 200B-16DO	Table 7-5
	ET 200B-8DI/8DO	Table 7-9
	ET 200B-8DI/8DO HWA	Table 7-10
	ET 200B-8RO	Table 7-8
TB2/DC, TB2-4/DC, TB4/DC and TB4M/DC	ET 200B-16DO/2A	Table 7-6
	ET 200B-32DI, ET 200B-32DI 0.2ms	Table 7-4
	ET 200B-32DO	Table 7-7
	ET 200B-16DI/16DO	Table 7-12
	ET 200B-24DI/8DO, ET 200B-24DI/8DO 0.2ms	Table 7-13
TB6/AC	ET 200B-16DI-AC	Table 7-14
	ET 200B-16DO-AC	Table 7-15
	ET 200B-16RO-AC	Table 7-16
	ET 200B-8DI/8RO-AC	Table 7-17
TB8-analog	ET 200B-4/8AI	Table 8-37
	ET 200B-4AI	Table 8-55
	ET 200B-4AO	Table 8-65

Shielding for Analog Value Processing

For analog value processing, connect the cable shields of the signal lines directly at the TB8 to the shield connecting element (Order No.: 6ES7 193-0CD40-7XA0).

Procedure for Connecting the Shielding

Follow the steps listed below:

1. Engage the TB8 terminal block on the shield connecting element after first mounting the shield connecting element on the standard sectional rail or a smooth surface (wall) (see Section 3.1).
2. Mount the metallic terminal elements (see Section 3.1) on the bottom edge of the shield connecting element (1 and 2).
3. Strip the ends of the signal lines.
4. Secure the bare cable ends to the terminal elements (3 and 4).
5. Connect the shield connecting element to the protective ground conductor (PE). The cross-section of PE must be a minimum of 4 mm² and a maximum of 10 mm².
6. Connect the shield of the bus cable in such a way that the maximum bend radius when bent once ($10 \times d_O$; d_O = outer diameter of the cable) is not exceeded.

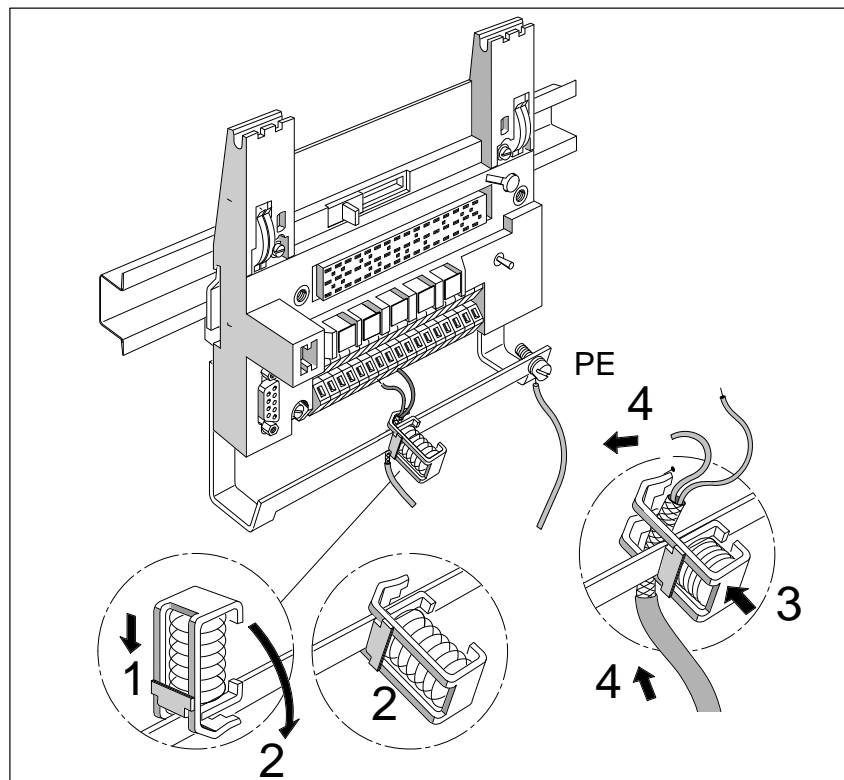

Figure 3-16 Shield Connecting Element on Terminal Block TB8

3.6 Wiring the Bus Interface

Bus Interface The PROFIBUS-DP bus connects to the terminal block by means of a bus connector.

Bus Connector There are a number of bus connectors for ET 200B.

Table 3-5 Bus Connectors

Design		Order Number
max. 12 Mbaud	without programmer socket	6ES7 972-0BA10-0XA0 ¹
	with programmer socket	6ES7 972-0BB10-0XA0 ¹
max. 1.5 Mbaud (without terminating resistor)	without programmer socket	6ES7 972-0BA30-0XA0

¹ When inserted, the installation height for the ET 200B module is not exceeded with this bus connector.

PROFIBUS-DP Interface The pin assignment of the 9-pin PROFIBUS-DP interface of the terminal block is described below.

Table 3-6 Pin Assignment of the PROFIBUS-DP Interface

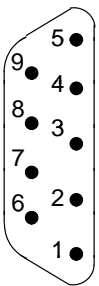
View ²	Pin No.	Signal Name	Designation
	1	–	–
	2	–	–
	3	RxD/TxD-P	Data line B
	4	RTS	Request To Send
	5	M5V2	Data reference potential (from station)
	6	P5V2	Supply plus (from station)
	7	–	–
	8	RxD/TxD-N	Data line A
	9	–	–

² Terminal block as viewed from in front

Connecting the Bus Cable

The procedure for connecting the bus cable to the bus connector is described in detail in the following manuals:

- Manual *ET 200 Distributed I/O System*
- Manual *S7-300 Programmable Controller Hardware and Installation*
- Manual *M7-300 Programmable Controller Hardware and Installation*
- Manual *S7-400/M7-400 Programmable Controller Hardware and Installation*

Dimensional Drawings with Bus Connectors

Chapters 7 and 8 contain dimensional drawings of ET 200B modules with bus connectors installed.

Configuration and Parameterization

4

In this Chapter

Before startup, you must configure and parameterize the modules of the ET 200B distributed I/O station.

This chapter contains information on:

In Section	you will find	on Page
4.1	Configuration Options	4-2
4.2	Requirements for Configuration	4-3
4.3	Where to Find the Requisite Information?	4-5

4.1 Configuration Options

Options

You can configure and parameterize the ET 200B modules described in this manual as DP slaves:

- with COM ET 200 version 4.x or higher
 - version 4.0 or higher: digital modules
 - version 4.1 or higher: analog modules
- with COM ET 200 Windows version 1.0 or higher
- with STEP 7 version x.0 or higher
 - version 2.0 or higher: digital modules
 - version 3.0 or higher: analog modules
- directly by means of configuration and parameterization telegrams (for DP masters from Siemens that do not belong to the SIMATIC S5/S7/M7 automation system and other-vendor DP masters).

S7 Slave

The analog modules of ET200B can be operated as S7 slaves in conjunction with SIMATIC S7/ M7 and STEP 7 (V3.0 and higher). This means that all the functions of the central S7 I/O modules are also at your disposal for the ET 200B analog modules.

4.2 Requirements for Configuration

Type File

COM ET 200 V4.x, COM ET 200 Windows and STEP 7 require a type file for each ET 200B module (DP slave). The type file is a record of all the properties of the module concerned.

You do not need a type file to operate ET 200B analog modules as S7 slaves.

Before you start working with the software, check that the type file of the ET 200B module is installed in a type-file directory recognized by the software. The names of the type files are listed in Appendix A.1.

If you do not have a type file for ET 200B, you can fetch the type file you need via modem. The number to dial is +49 (911) 737972.

GSD File

You do not need a device master data file (GSD file) unless you are going to use ET 200B with a DP master that cannot process the type file. The GSD file contains all the slave-specific properties.

The format of the GSD file is defined in EN 50170, Part 3. The contents of the GSD files are described in Appendix A.2.

You can order the GSD file on diskette (Order No. 6ES7 190-1AA00-0AA0) or fetch it via modem. The modem number to dial is +49 (911) 737972.

Which Type File?

There are a number of type file versions for the ET 200B modules; the version you need depends on the parameterization software and the master.

The type file version is indicated by the seventh character in the type file name (example: SIxxxxAD.200), "xxxx" is the module's manufacturer ID.

The 8th character in the type file name indicates the language:
 D = German, E = English, F = French, I = Italian, S = Spanish,
 X = non-language-specific (example: SIxxxxAE.200 for an English type file).

The type file versions and their applications are listed in the table below.

Table 4-1 Type File Versions and Applications

Parameterization software	COM ET 200 V4.x	COM ET 200 Windows (V1.0 and higher)		STEP 7 ¹ (as DP slave)
Master	IM 308-B	IM 308-C		S7/M7 DP master
ET 200B digital modules				
Type file ²	SIxxxxTE.200	SIxxxxAE.200 or SIxxxxAX.200		SIxxxxAE.200 or SIxxxxAX.200
Parameterization	no settings possible			
Configuration	DP ID	DP ID		DP ID
Diagnostics	13 bytes	13 bytes		13 bytes
ET 200B analog modules				
Type file ²	SIxxxxTE.200	SIxxxxAE.200	SIxxxxBE.200	SIxxxxBE.200
Parameterization	32 bytes (KH format)	32 bytes (plain text with pick list)	36 bytes ³ (plain text with pick list)	36 bytes ³ (plain text with pick list)
Configuration	DP ID	DP ID	extended DP ID, single-channel addressing possible	extended DP ID, single-channel addressing possible
Diagnostics	16 bytes	21/25 bytes	25/29 bytes	25/29 bytes

These applications are taken into account in Chapters 5 through 8; important information on the other applications is contained in the Appendix.

¹ STEP 7 version 2.0 and higher for digital modules, STEP 7 version 3.0 and higher for analog modules
² xxxx = manufacturer ID of the ET 200B module (see Section A.1)
³ Analog modules with additional functions: limit-value alarm, diagnostics alarm, 4AO supporting dummy-value output, other measuring ranges

4.3 Where to Find the Requisite Information?

COM ET 200 Windows and STEP 7

Chapters 5 through 8 contain information on configuration, parameterization and diagnostics that you will need if you are working with the latest type files under COM ET 200 Windows or STEP 7 (see Table 4-1: gray fields).

If you use COM ET 200 Windows or STEP 7 to configure and parameterize ET 200B modules, the graphical user interfaces and the integral online help systems of these programs provide additional support.

The manual *ET200 Distributed I/O System* (Order No. 6ES5 998-3ES12) contains general information on working with COM ET 200 Windows.

Basic information on configuring and parameterizing distributed I/O with STEP 7 is contained in the user manual entitled *Standard Software for S7 and M7, STEP 7*.

COM ET 200 Windows (Old Type File)

If you configure and parameterize ET 200B analog modules with COM ET 200 Windows and the type file SIxxxxAE.200, you will find the requisite supplementary information in Appendix E of this manual.

COM ET 200 Version 4.x

If you configure and parameterize ET 200B modules with COM ET 200 version 4.x, you will find the information you need in Appendix D of this manual.

Configuration and Parameterization Telegram

If you use configuration and parameterization telegrams to operate ET 200B, e.g. CP 5431 as DP master, you need the details of the layout of the configuration and parameterization telegram, which is module-specific (see Appendix B and C).

5

Status and Error Diagnostics

In this Chapter

This chapter describes the diagnostics options for the ET 200B distributed I/O station.

The information is applicable if you are using the latest applicable type file under COM ET 200 Windows or STEP 7 (see Table 4-1: gray fields).

In Section	you will find	on Page
5.1	Possible response on startup	5-2
5.2	Status and error indication by LEDs	5-3
5.3	Slave diagnostics	5-5

Diagnostics with IM 308-B

Diagnostics with the IM 308-B master interface and COM ET 200 V4.x is not discussed in this chapter. You will find all the information you need on diagnostics with the IM 308-B in Appendix D.

Diagnostics with IM 308-C (Old Type Files)

If you configure the analog modules of ET 200B with COM ET 200 Windows and the type file SIxxxxAE.200, you will find the information you need on diagnostics in Appendix E.

5.1 Possible Response on Startup

Response to Power Off/Power On

If power is switched on and off repeatedly, it is possible in exceptional cases that an ET 200B digital module will not be accepted by the PROFIBUS-DP bus.

Remedy:

Set the STOP/RUN switch to STOP and then back to RUN.

Baud Rate Change

With the ET 200B digital modules, it is not possible to correct a wrong configuration and simultaneously change the baud rate. If this is attempted, the station will not be accepted by the PROFIBUS-DP bus.

Remedy:

Set the STOP/RUN switch to STOP and then back to RUN.

5.2 Status and Error Indication by LEDs

Introduction The indicators on the front panels of the ET 200B provide initial indication of the type of error.

Error Indication, Digital ET 200B The meanings of the signals provided by the LEDs on digital ET 200B modules are listed in the table below.

Table 5-1 LEDs on Digital ET 200B Modules and their Meanings

LED	State	Meaning
RUN	Lit (green)	ET 200B in operation (power supply switched on; STOP/RUN switch in "RUN" position ¹)
BF	Lit (red)	Either <ul style="list-style-type: none"> Response monitoring time has elapsed without the ET 200B station being addressed (because connection to the IM 308-C or to the S7/M7 DP master has failed or the IM 308-C is set to STOP) or <ul style="list-style-type: none"> The ET 200B station was not parameterized on startup/restart.
DIA	Lit (red)	For digital 24 V DC output modules: <ul style="list-style-type: none"> one output at least: short-circuit or load voltage failure (L1+, L2+, L3+, L4+) For analog modules: <ul style="list-style-type: none"> diagnostics for at least one input or output
L1+	Lit (green)	For ET 200B-16DO, -8DI/8DO, -8DI/8DO HWA, -16DI/16DO, -24DI/8DO and -24DI/8DO 0.2ms: <ul style="list-style-type: none"> Voltage is applied for channel group Q0: .07.²
L2+	Lit (green)	For ET 200B-16DO, -16DI/16DO: <ul style="list-style-type: none"> Voltage is applied for channel group Q1: .07.²
L1+/L2+	Lit (green)	For ET 200B-32DO: <ul style="list-style-type: none"> Voltage is applied for channel groups Q0: .07 and Q1: .07.² For ET 200B-16DO/2A: <ul style="list-style-type: none"> Voltage is applied for channel groups Q0: .03 and Q0: .47.²
L3+/L4+	Lit (green)	For ET 200B-32DO: <ul style="list-style-type: none"> Voltage is applied for channel groups Q2: .07 and Q3: .07.² For ET 200B-16DO/2A: <ul style="list-style-type: none"> Voltage is applied for channel group Q1: .03 and Q1: .47.²

¹ Not applicable to AC 120/230 V AC digital modules. These modules do not have a STOP/RUN switch.

² LED goes out if fuse blows or voltage drops below a certain limit (typically 15.5 V).

**Error Indication,
Analog ET 200B**

The meanings of the signals provided by the LEDs on analog ET 200B modules are listed in the table below.

Table 5-2 LEDs on Analog ET 200B Modules and their Meanings

LED RUN	LED BF	LED DIA	Meaning	Remedy
Off	Off	Off	Voltage not applied to module.	<ul style="list-style-type: none"> • Check the power supply. • Check that the electronics block is correctly mounted on the terminal block.
Lit (green)	Off	Off	Module is on the PROFIBUS-DP and is exchanging data.	-
Lit (green)	Lit (red) or off	Lit (red)	An error has occurred on the module (e.g. parameterization incorrect, wire break, measuring range overshoot)	<ul style="list-style-type: none"> • Read the diagnostics buffer to identify the error, see Section 5.3 "Slave Diagnostics" • If there is no diagnostics information in the buffer, check parameterization to ascertain whether the diagnostics alarm and corresponding channel diagnostics have been enabled.
Lit (green)	Flashing (red)	Off	Either <ul style="list-style-type: none"> • Module has not received a parameterization telegram, or telegram is incorrect. or <ul style="list-style-type: none"> • Incorrect bus protocol. 	Check the configuration in the DP master (station number, station type).
Lit (green)	Flashing (red)	Lit (red)	Error in configuration telegram	This error cannot occur if the correct type files are used.
Lit (green)	Flashes once (red)	Off	Module is powering up.	-
Lit (green)	Lit (red)	No significance	Baud rate matching in progress.	<ul style="list-style-type: none"> • Check the PROFIBUS-DP connection. • Check the DP master.

5.3 Slave Diagnostics

Definition

Diagnostics means the detection and pinpointing of errors. The layout of slave diagnostics is defined in standard EN 50170, Part 3. Slave diagnostics of the ET 200B are in compliance with this standard.

In this Section

This section describes the structure of slave diagnostics for ET 200B.

In Section	you will find	on Page
5.3.1	General information on slave diagnostics, operation with IM 308-C	5-6
5.3.2	General information on slave diagnostics, operation with S7/M7 DP masters (STEP 7) or other PROFIBUS-DP masters	5-8
5.3.3	Structure of slave diagnostics	5-9
5.3.4	Structure of station status 1 to 3	5-11
5.3.5	Structure of the master station number and the manufacturer ID	5-13
5.3.6	Structure of device-related diagnostics (digital ET 200B)	5-14
5.3.7	Structure of ID-related diagnostics (analog ET 200B)	5-16
5.3.8	Structure of device-related diagnostics (analog ET 200B)	5-18

Further Information

Section 5.3.3 describes the basic structure of slave diagnostics for digital and analog ET 200B modules. Sections 5.3.4 to 5.3.8 describe the contents of the individual diagnostics bytes.

5.3.1 General Information on Slave Diagnostics, Operation with IM 308-C

Requesting Slave Diagnostics

To request slave diagnostics for an ET 200B station in operation with IM 308-C, you must call the FB IM308C function block (FB 192) with the function FCT = SD.

The FB IM308C places the slave diagnostics in the S5 data area of the CPU (data block or bit memory address area) opened when the FB IM308C was called.

FM IM308C

FB IM308C handling conforms to general access to diagnostics data of the IM 308-C and is described in detail in the manual *ET200 Distributed I/O System* (Order No. 6ES5 998-3ES.2).

The example below shows how to request slave diagnostics with the aid of the FB IM308C and place the information in a data block.

This is followed by an example illustrating how to evaluate slave diagnostics. This second example assumes that the diagnostics information has been placed in a data block.

Note

The module parameters of the FB IM308C and the error codes in the ERR parameter of the FB IM308C are described in detail in the manual *ET 200 Distributed I/O System* (Order No. 6ES5 998-3ES.2).

Example: Request Diagnostics with FB IM308C

In this example, the FB IM308C (FB 192) is employed to request slave diagnostics of a slave having the station number 3. The diagnostics data will be placed in data block DB 10 as of data word DW 0.

Basic structure of the STEP 5 listing (e.g. in the OB 1):

STL	Explanation
:	
:JU FB 192	Invoke FB IM308C
Name :IM308C	DP frame: F800
DPAD : KH F800	Number of the IM 308-C: 0, station number of the slave: 3
IMST : KY 0,3	
FCT : KC SD	SD = Read slave diagnostics
GCGR : KM 00000000 00000000	irrelevant
TYP : KY 0,10	Memory area: 0, block: DB10
STAD : KF +0	Number of the first data word: DW0
LENG : KF -1	Bytes to be transferred: -1 (joker length)
ERR : FW 134	Error word: MW 134
:	
:***	

**Example:
Evaluating Diagnostics**

The slave diagnostics of a digital ET 200B module have been requested from the CPU and placed in a data block DB 10 starting at data word DW 0. You want to evaluate station status 1 and 2.

In the STEP 5 program, you program the following:

STL	Explanation
A DB 10	Invoke data block (here: DB 10) Load diagnostics word "Station status 1 and station status 2" (response monitoring active)
L DW 0	
L KH 000C	
!=F	no error?
BEC	
JC FBx	Evaluate error in FBx.

Diagnostics Alarm and Process Alarm

The analog modules of ET 200B support the following alarms:

- Diagnostics alarm
- Process alarm

In order to evaluate diagnostics alarms and process alarms via the device-related diagnostics with the IM 308-C, it is important to bear the following in mind:

Note

In your STEP5 application program you must regularly query the corresponding bits in the device-related diagnostics in order to ensure that alarms are not overwritten by subsequent alarms.

With regard to the bus runtime for the PROFIBUS-DP you must allow for the fact that the bits are queried at least once parallel to the bus runtime.

Structure of Slave Diagnostics

The structure of slave diagnostics for operation with IM 308-C is described in Sections 5.3.3 to 5.3.8.

5.3.2 General Information on Slave Diagnostics, Operation with S7/M7 DP Masters (STEP 7) or Other PROFIBUS-DP Masters

Diagnostics with S7/M7 DP Masters

If you operate the ET 200B as a DP slave with a **SIMATIC S7/M7** DP master, the ET 200B modules function like central S7-300 I/O modules.

You read out diagnostics (data records 0 and 1) with SFC 13 "DPNRM_DG". For information on requesting diagnostics data, see the manual *STEP 7 Standard and System Functions*.

Diagnostics with Other PROFIBUS-DP Masters

If you operate ET 200B as DP slave with DP masters from Siemens that do not belong to the SIMATIC S5/S7/M7 automation system or with other-vendor DP masters, see the documentation on the DP master for information on how to request slave diagnostics.

Diagnostic Alarm and Process Alarm

The analog modules of ET 200B support the following alarms:

- Diagnostics alarm
- Process alarm

You can evaluate these alarms with an S7/M7 DP master. In the event of an alarm, alarm OBs are automatically run in the CPU (see the programming manual *System Software for S7-300/S7-400, Program Design*).

Note

If you want to evaluate diagnostics alarms and process alarms via the device-related diagnostics with other than PROFIBUS-DP masters, you must bear the following in mind:

- The DP master should be able to store the diagnostics messages, i.e. the diagnostics messages should be placed in a ring buffer in the DP master. If the DP master cannot store diagnostics messages, only the most recently received diagnostics message will be available.
 - In your application program you must regularly query the corresponding bits in the device-related diagnostics. With regard to the bus runtime for the PROFIBUS-DP you must allow for the fact that the bits are queried at least once parallel to the bus runtime.
-

Structure of Slave Diagnostics

The structure of slave diagnostics for operation with S7/M7 DP masters (STEP 7) or other PROFIBUS-DP masters is described in Sections 5.3.3 to 5.3.8.

5.3.3 Structure of Slave Diagnostics

Introduction

A certain number of bytes is reserved per slave for slave diagnostics: the precise number of bytes reserved depends on the station type.

Diagnostics of the ET 200B distributed I/O station is in compliance with EN 50170, Part 3. The basic structure of slave diagnostics is described below.

Digital ET 200B

The figure below shows the structure of slave diagnostics for digital ET 200B modules:

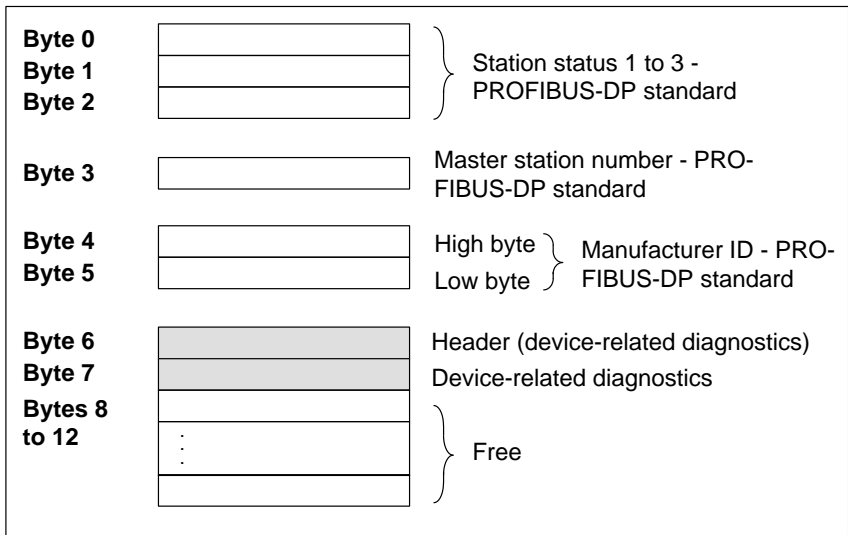

Figure 5-1 Structure of Slave Diagnostics for Digital ET 200B

Analog ET 200B

The figure below shows the structure of slave diagnostics for for analog ET 200B modules:

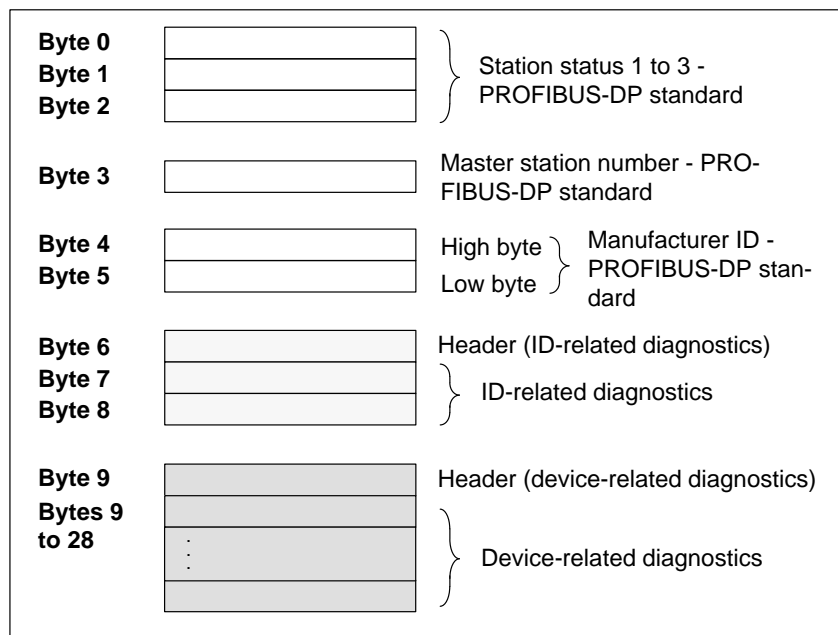

Figure 5-2 Structure of Slave Diagnostics for Analog ET 200B

Requesting Slave Diagnostics

You can request slave diagnostics with the following function blocks:

Table 5-3 Function Blocks for Slave Diagnostics

PLC Family	Number	Name
SIMATIC S5 with IM 308-C	FB 192	FB IM308C
SIMATIC S7/M7	SFC 13	SFC "DPNRM_DG"

5.3.4 Structure of Station Status 1 to 3

Introduction

Station status 1 ... 3 provides an overview of the status of the ET 200B (see Figures 5-1 and 5-2, bytes 0 to 2).

Station Status 1 (Byte 0)

The table below shows the structure of station status 1:

Table 5-4 Structure of Station Status 1 (Byte 0)

Bit	Meaning
0	1: DP slave cannot be addressed by DP master.
1	1: DP slave not yet ready for data exchange.
2	1: Configuration data sent by DP master to DP slave does not match the structure of the DP slave.
3	1: Device-related diagnostics data is waiting.
4	1: Requested function is not supported by DP slave.
5	1: Implausible answer received from DP slave.
6	1: parameterization telegram is errored.
7	1: DP slave was parameterized by a DP master not the DP master which currently has access to the DP slave.

Station Status 2 (Byte 1)

The table below shows the structure of station status 2:

Table 5-5 Structure of Station Status 2 (Byte 1)

Bit	Meaning
0	1: DP slave must be reparameterized.
1	1: A diagnostics message is waiting. The DP slave cannot resume operation until the error has been rectified (static diagnostics message).
2	1: Bit is always "1" if DP slave having this station number exists.
3	1: Response monitoring is activated for this slave.
4	1: DP slave has received a "FREEZE" control command. ¹
5	1: DP slave has received a "SYNC" control command. ¹
6	0: Bit is always "0".

Table 5-5 Structure of Station Status 2 (Byte 1), continued

Bit	Meaning
7	1: DP slave is deactivated, i.e. slave has been removed from current processing.

¹ Bit is not updated unless an extra diagnostics message changes.

**Station Status 3
(Byte 2)**

Station status 3 is reserved and is not relevant as regards diagnostics of the DP slave. Its value is always 00_H.

5.3.5 Structure of the Master Station Number and the Manufacturer ID

Introduction

The "Master station number" diagnostics byte contains the station number of the DP master which parameterized the ET 200B. The "Manufacturer ID" diagnostics byte describes the type of the ET 200B.

Master Station Number (Byte 3)

The master station number consists of one byte (see Figures 5-1 and 5-2):

Table 5-6 Structure of the Master Station Number (Byte 3)

Bit	Meaning
0 to 7	Station number of the DP master which parameterized the DP slave and which has read and write access to the DP slave.

Manufacturer ID (Bytes 4, 5)

The manufacturer ID consists of two bytes (see Figures 5-1 and 5-2):

Table 5-7 Structure of the Manufacturer ID (Bytes 4, 5)

Byte 4	Byte 5	Manufacturer ID for	
00 _H	01 _H	ET 200B-16DI	6ES7 131-0BH00-0XB0
00 _H	02 _H	ET 200B-16DO	6ES7 132-0BH01-0XB0
00 _H	03 _H	ET 200B-8RO	6ES7 132-0GF00-0XB0
00 _H	04 _H	ET 200B-32DI	6ES7 131-0BL00-0XB0
00 _H	05 _H	ET 200B-16DO/2A	6ES7 131-0BH11-0XB0
00 _H	0A _H	ET 200B-16DI/16DO	6ES7 133-0BL00-0XB0
00 _H	0B _H	ET 200B-8DI/8DO	6ES7 133-0BH01-0XB0
00 _H	0C _H	ET 200B-32DI 0.2ms	6ES7 131-0BL10-0XB0
00 _H	0D _H	ET 200B-32DO	6ES7 132-0BL01-0XB0
00 _H	0E _H	ET 200B-24DI/8DO 0.2ms	6ES7 133-0BN11-0XB0
00 _H	0F _H	ET 200B-24DI/8DO	6ES7 133-0BN01-0XB0
00 _H	10 _H	ET 200B-8DI/8DO HWA	6ES7 133-0BH10-0XB0
00 _H	19 _H	ET 200B-16DI-AC	6ES7 131-0HF00-0XB0
00 _H	1A _H	ET 200B-16DO-AC	6ES7 132-0HF00-0XB0
00 _H	1C _H	ET 200B-16RO-AC	6ES7 132-0HH00-0XB0
00 _H	1D _H	ET 200B-8DI/8RO-AC	6ES7 133-0HH00-0XB0
80 _H	18 _H	ET 200B-4AO	6ES7 135-0HF01-0XB0
80 _H	19 _H	ET 200B-4AI	6ES7 134-0HF01-0XB0
80 _H	1A _H	ET 200B-4/8AI	6ES7 134-0KH01-0XB0

5.3.6 Structure of Device-Related Diagnostics (Digital ET 200B)

Introduction

The device-related diagnostics for digital ET 200B modules indicate whether inputs or outputs are defective. The header indicates the length of the device-related diagnostics. (see Figure 5-1, bytes 6 and 7)

Note

Device-related diagnostics requires an ET 200B station with diagnostics capability.

ET 200B stations which do **not** have diagnostics capability have the value "07_H" in the header and the remaining bytes are reserved.

Header (Byte 6)

Digital ET 200B modules have the value 07_H in the "Header (device-related diagnostics)" byte.

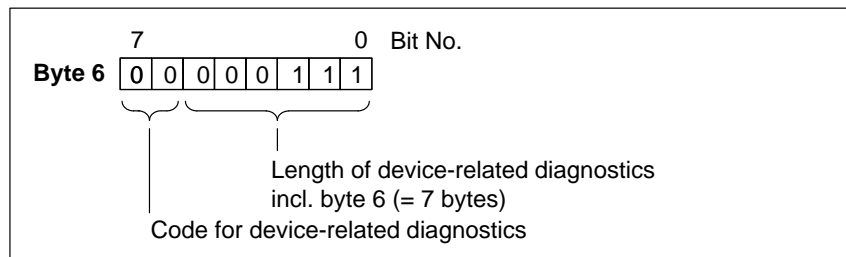

Figure 5-3 Structure of the Header (Device-Related Diagnostics) for Digital ET200B (Byte 6)

Device-Related Diagnostics (Byte 7)

The device-related diagnostics of digital ET 200B modules with diagnostics capability consists of one byte (see Figure 5-1):

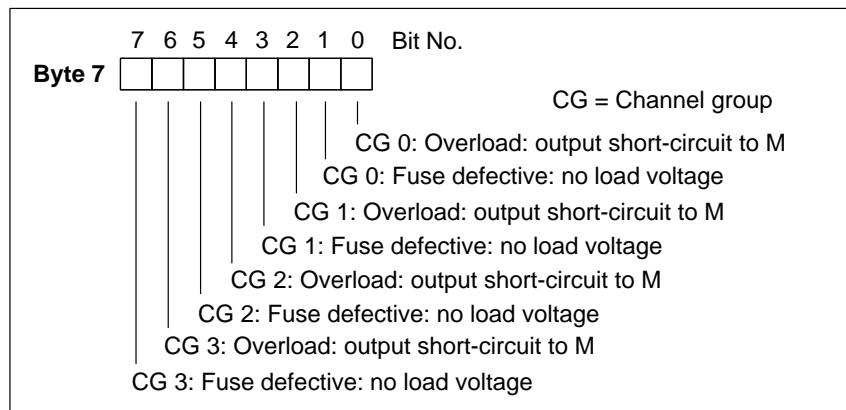

Figure 5-4 Structure of Device-Related Diagnostics for Digital ET 200B (Byte 7)

Channel Group

Note the following as regards evaluation of device-related diagnostics:

Note

The channel group of an ET 200B digital module always takes up one byte in the S5 address space of the CPU (corresponding to 8 inputs or 8 outputs), irrespective of the galvanic isolation of the module (grouping).

Example: ET 200B-16DO/2A (galvanic isolation in groups of 4)

Channel group 0 corresponds to Q0: outputs .07.

Potential group 0 corresponds to Q0: outputs .03.

5.3.7 Structure of ID-related Diagnostics (Analog ET 200B)

Introduction ID-related diagnostics shows which module in which slot is defective. The header indicate the length of ID-related diagnostics. (see Figure 5-2, bytes 6 to 8)

Header (Byte 6) Analog ET 200B modules have the value 43H in the "Header (ID-related diagnostics)" byte.

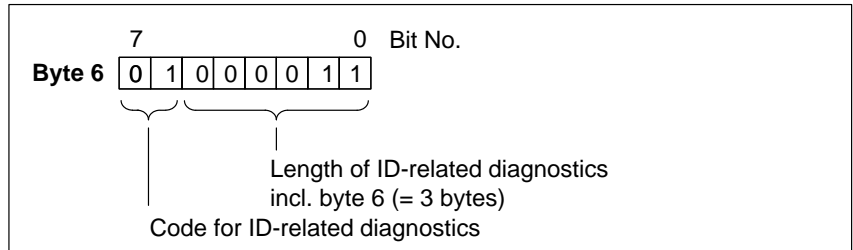

Figure 5-5 Structure of the Header (ID-related Diagnostics) for Analog ET200B (Byte 6)

ID-related Diagnostics (Bytes 7, 8) The ID-related diagnostics of analog ET 200B modules consists of two bytes (see Figure 5-2):

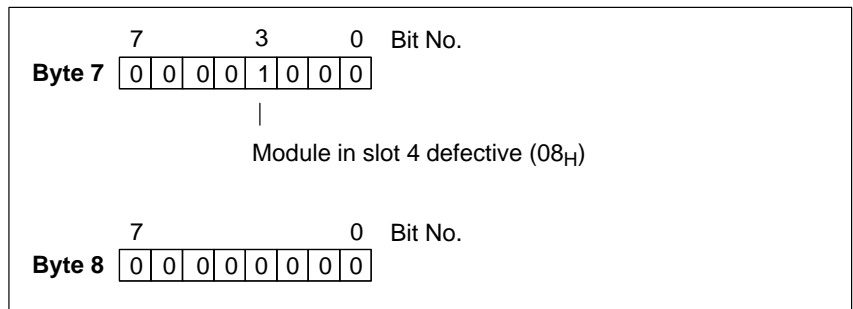

Figure 5-6 Structure of ID-related Diagnostics for Analog ET 200B (Bytes 7, 8)

Note

Irrespective of the configuration of the analog ET 200B module (slots 4 to 11), slot 4 is always flagged as defective in a diagnostics message!

Configuration Error

If a configuration telegram contains an error, only the 3-byte ID-related diagnostics (bytes 6, 7, 8) is returned and **no** device-related diagnostics.

If the configuration telegram contains an error, the structure of ID-related diagnostics is as follows:

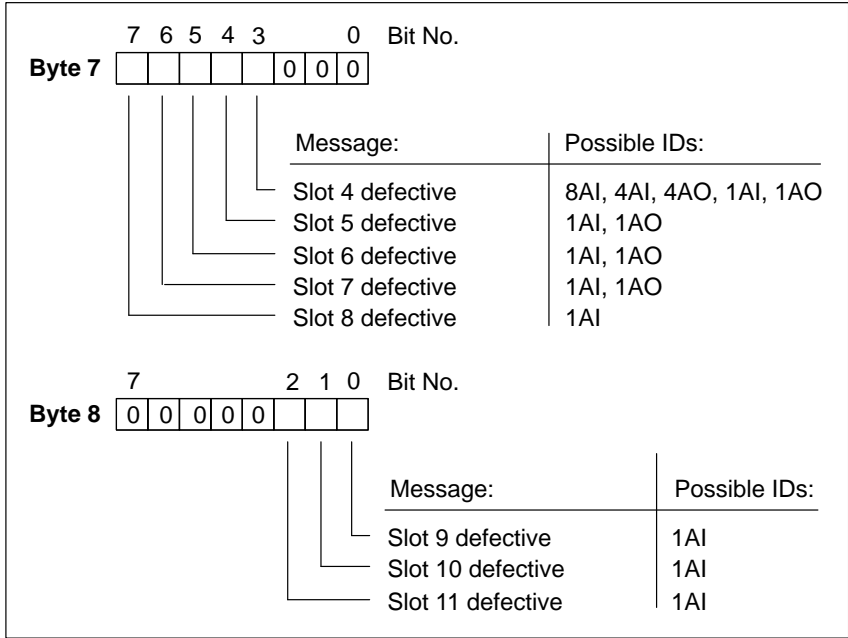

Figure 5-7 Structure of ID-related Diagnostics for Analog ET 200B (Bytes 7, 8) in the Event of an Error in the Configuration Telegram

Note

If there is an error in the configuration telegram, the configured slots of the analog ET 200B module the configurations of which are errored are shown.

If the error in the configuration telegram is general (e.g. wrong length), the value FF_H is returned for bytes 7 and 8.

5.3.8 Structure of Device-Related Diagnostics (Analog ET 200B)

Introduction

The device-related diagnostics for an analog ET 200B shows you the error reported by the ET 200B. The header indicates the length of device-related diagnostics. (see Figure 5-2, bytes 9 to 28)

Note

Chapter 8 contains a discussion of "Supplementary Bits" in the section dealing with analog value representation: these bits contain additional diagnostics information.

The structure of the device-related diagnostics for configuration of analog modules with the latest type file version **SIxxxxBE.200** is described below. If you configure with the type file SIxxxxAE.200, please turn to Appendix E.2.

Header (Byte 9)

The analog ET 200B modules contain the following information in the "Header (device-related diagnostics)" byte:

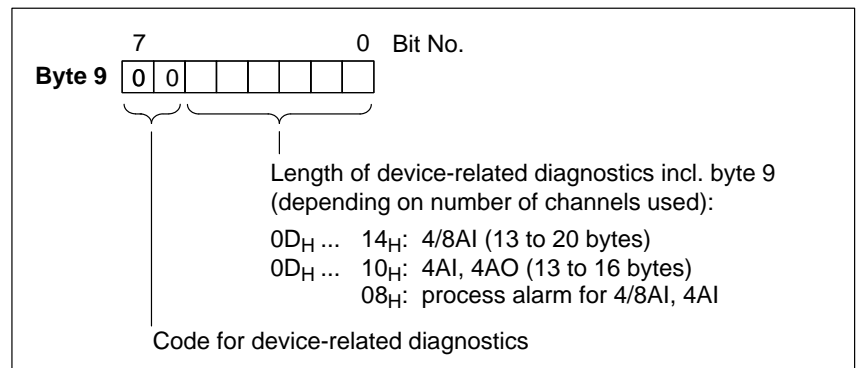

Figure 5-8 Structure of the Header (Device-Related Diagnostics) for Analog ET200B (Byte 9)

Device-Related Diagnostics

Device-related diagnostics of the analog ET 200B modules comprises a maximum of 19 bytes:

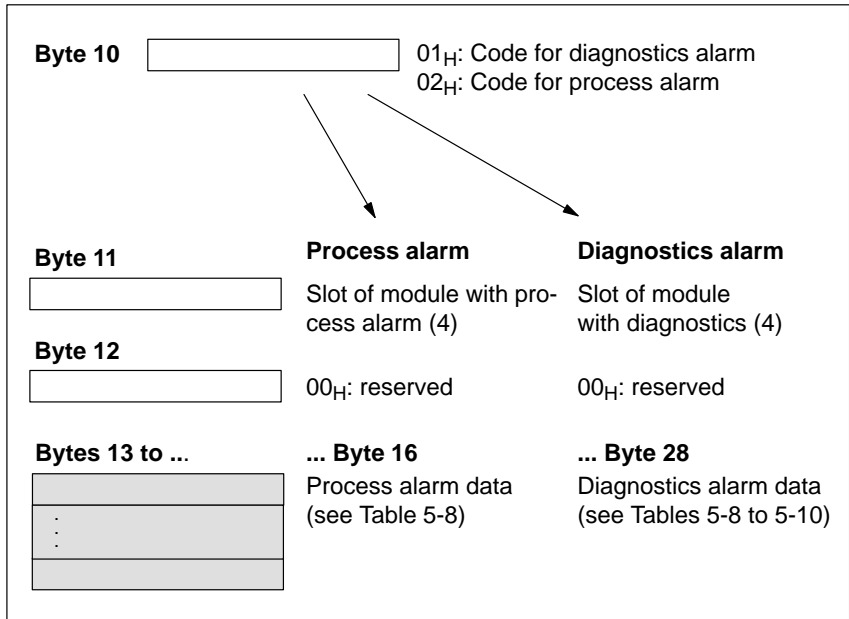

Figure 5-9 Structure of Device-Related Diagnostics for Analog ET 200B (Bytes 10 to 28)

Bytes 13 to 16

Table 5-8 shows the structure and contents of bytes 13 to 16.

Table 5-8 Bytes 13 to 16 for Diagnostics and Process Alarms

Byte	Bit	Byte 10 = 01 _H (Diagnostics Alarm)	Byte 10 = 02 _H (Process Alarm)		
13 (→ Tab. 5-9)	0	Module defect	Channel 0	Upper limit value overshoot (4/8AI, 4AI)	FF _H : End-of-cycle alarm (4/8AI)
	1	Internal error	Channel 1	Upper limit value overshoot (4/8AI ¹)	
	2	External error	Channel 2	Upper limit value overshoot (4/8AI ¹ , 4AI)	
	3	Channel error	Channel 3	Reserved	
	4	Reserved	Channel 4	Reserved	
	5	Reserved	Channel 5	Reserved	
	6	Parameterization missing	Channel 6	Reserved	
	7	Incorrect parameters in module	Channel 7	Reserved	

¹ For the ET 200B-4/8AI, only the combination of single channel addressing **and** parameterization of channel group 0 for resistance measurement (Pt 100, Ni 100, R) entails display of "Upper/lower limit value overshoot" for channel 1. In all other cases (i.e. module addressing and single channel addressing **and** parameterization of channel group 0 for other than resistance measurement (Pt 100, Ni 100, R), "Upper/lower limit value overshoot" is displayed for channel 2.

Table 5-8 Bytes 13 to 16 for Diagnostics and Process Alarms, continued

Byte	Bit	Byte 10 = 01 _H (Diagnostics Alarm)			Byte 10 = 02 _H (Process Alarm)		
14	0 to 3	Module class	0101	Analog module	Channel 0	Lower limit value overshoot (4/8AI, 4AI)	00 _H : Reserved
					Channel 1	Lower limit value overshoot (4/8AI ¹)	
					Channel 2	Lower limit value overshoot (4/8AI ¹ , 4AI)	
					Channel 3	Reserved	
	4	Channel information available			Channel 4	Reserved	
	5	Reserved			Channel 5	Reserved	
	6	Reserved			Channel 6	Reserved	
	7	Reserved			Channel 7	Reserved	
15	0	Wrong ET 200B station type			00 _H : Reserved		00 _H : Reserved
	1	Reserved					
	2	Reserved					
	3	Reserved					
	4	Reserved					
	5	Reserved					
	6	Reserved					
	7	Reserved					
16	0	Reserved			00 _H : Reserved		00 _H : Reserved
	1	Reserved					
	2	EPROM error (4AI)					
	3	Reserved					
	4	ADC/DAC error (4AO)					
	5	Reserved					
	6	Process alarm lost (4/8AI, 4AI)					
	7	Reserved					

Possible Values, Byte 13 In a diagnostics alarm the possible values of byte 13 are as follows:

Table 5-9 Possible Values for Byte 13 in Diagnostics Alarm

Value	Bit 3	Bit 2	Bit 1	Bit 0	Meaning
00 _H	0	0	0	0	No error
03 _H (83 _H)	0	0	1	1	Internal error, no channel error; (incorrect parameters in the module)
0B _H (8B _H)	1	0	1	1	Internal error, channel error; (incorrect parameters in the module)
0D _H	1	1	0	1	External error, channel error
0F _H (8F _H)	1	1	1	1	Summation error of all above errors; (incorrect parameters in the module)

**Bytes 17 to 28
(Diagnostics
Alarm)**

Table 5-10 shows the structure and contents of bytes 17 to 28 (for diagnostics alarm only).

Table 5-10 Bytes 17 to 28 for Diagnostics Alarm

Byte	Bit	Meaning	Remark	
17	0 to 7	Channel type	71 _H 73 _H	4/8AI, 4AI 4AO
18	0 to 7	Number of diagnostics bits output per channel by a module.	08 _H	4/8AI, 4AI, 4AO
19	0 to 7	Number of channels of a module.	01 _H to 04 _H 01 _H to 08 _H	4AI, 4AO 4/8AI
20	Channel error vector:			
	0	Channel error, channel 0	4/8AI, 4AI, 4AO	
	1	Channel error, channel 1	4/8AI, 4AI, 4AO	
	2	Channel error, channel 2	4/8AI, 4AI, 4AO	
	3	Channel error, channel 3	4/8AI, 4AI, 4AO	
	4	Channel error, channel 4	4/8AI	
	5	Channel error, channel 5	4/8AI	
	6	Channel error, channel 6	4/8AI	
7	Channel error, channel 7	4/8AI		
21 to 28 ¹	-	Channel-specific errors	See Table 5-11	

¹ The number of bytes depends on the number of channels in the module.

Analog Channel

Table 5-11 shows the assignment of the diagnostics byte for an analog input or analog output channel.

Table 5-11 Diagnostics Byte for an Analog Input/Analog Output Channel

Byte	Bit	Analog Input Channel (4/8AI, 4AI)	Analog Output Channel (4AO)
≅ 21	0	Configuration/parameterization error	
	1	Common-mode error (4/8AI only)	"0" (reserved)
	2	"0" (reserved)	
	3	"0" (reserved)	Ground short-circuit
	4	Wire-break/feed-current monitoring: meas. transducer/Pt 100/Ni 100/R ¹	
	5	"0" (reserved)	"0" (reserved)
	6	Measuring range overshoot	"0" (reserved)
	7	Measuring range overshoot	"0" (reserved)

¹ In the case of the ET 200B-4/8AI, a "wire break" error is superimposed on common-mode and measuring-range errors occurring at the same time (common-mode and measuring-range errors are not signaled).

General Technical Specifications

What are General Technical Specifications?

The general technical specifications comprise the standards that all ET 200B modules satisfy, the test values they comply with and the criteria used to test all modules.

General Technical Specifications

The table below contains the general technical specifications of the ET 200B modules.

Climatic environ. conditions acc. to IEC 1131-2		Mechanical environmental conditions	
Operating temperature • Preferred installation (= horizontal installation on a vertical wall: see Figure 3-8) 0 to +60 °C (32 to 140 °F) • Other installation positions 0 to +40 °C (32 to 104 °F) (Air intake temperature, measured at the bottom of the module)		Vibration ¹ tested to IEC 68-2-6 • 10 Hz ≤ f < 57 Hz Const. amplitude 0.075 mm • 57 Hz ≤ f < 150 Hz Const. acceleration 1g • Mode of vibration Frequency sweeps with a rate of change of 1 octave/min. • Period of oscillation 10 frequency sweeps per axis in each of the 3 perpendicular axes • Operating conditions In accordance with IEC 1131-2	
Storage/transport temperature -40 to +70 °C (-40 to 158 °F)		Shock ¹ tested to IEC 68-2-27 • Type of shock Semi-sinusoidal • Strength of shock 15 g peak value, 11 ms duration • Direction of shock 2 shocks in each of the 3 perpendicular axes	
Relative humidity to DIN 40040 15 to 95 % (indoor), no condensation		Drop and topple to IEC 68-2-31 • Tested with Height of fall 100 mm (3.90 in.)	
Atmospheric pressure • Operating 795 to 1080 hPa • Storage/transport 660 to 1080 hPa			
Pollutants • SO ₂ ≤ 0.5 ppm (rel. humidity ≤ 60 %, no condensation) • H ₂ S ≤ 0.1 ppm (rel. humidity ≤ 60 %, no condensation)			

¹ Vibrations and shocks permanently reaching the specified values as well as bumps must be prevented by adequate measures.

Electromagnetic compatibility (EMC)/noise immunity		IEC/VDE safety information	
Static electricity to IEC 801-2	Discharge to all parts that are accessible to the operator during normal operation	Degree of protection to IEC 529	
<ul style="list-style-type: none"> • Test voltage 	8 kV air discharge 4 kV contact discharge (relative humidity 30 to 95%)	<ul style="list-style-type: none"> • Type • Class 	IP 20 I to IEC 536
Electromagnetic fields to IEC 801-3	Field strength 10 V/m	Insulation rating	
Fast transient burst to IEC 801-4, Class III		<ul style="list-style-type: none"> • Between electrically independent circuits and circuits connected to a central grounding point • Between all circuits and central grounding point (standard sectional rail) 	to DIN VDE 0160 (05.1988) and IEC 1131-2 to DIN VDE 0160 (05.1988) and IEC 1131-2
<ul style="list-style-type: none"> • Digital input/output module • Analog input/output module • Communications interface 	for V = 24 V 2 kV for V > 24 V 2 kV 2 kV 2 kV	Test voltage for a nominal voltage V_{input} of the circuits (AC/DC)	to DIN VDE 0160 and IEC 1131-2
		$V_{input} = 0$ to 50 V $V_{input} = 50$ to 125 V $V_{input} = 125$ to 250 V	500 V DC 1250 V AC 1500 V AC
		Radio interference suppression	to VDE 0871
		<ul style="list-style-type: none"> • Limit class 	A

UL/CSA Certification

ET 200B is certified as follows:
UL Recognition Mark
Underwriters Laboratories (UL) to
Standard UL 508, Report 116536
CSA Certification Mark
Canadian Standard Association (CSA) to
Standard C 22.2 No. 142, Report LR 48323

FM Certification

The AC 120/230 V digital modules of ET 200B are FM-certified as follows:
FM Certification to Factory Mutual Approval Standard Class Number 3611,
Class I, Division 2, Group A, B, C, D.



Warning

Risk of injury and damage to property.

In hazardous locations injury and damage to property can occur if you disconnect connections while an ET 200 is in operation.

In hazardous locations, always deenergize the ET 200 before disconnecting connections.



Warning

**WARNING - DO NOT DISCONNECT WHILE CIRCUIT IS LIVE
UNLESS LOCATION IS KNOWN TO BE NONHAZARDOUS**

CE certification

Our products satisfy the requirements of EU Directive 89/336/EC "Electromagnetic Compatibility" and the harmonized European standards (EN standards) cited therein.



In accordance with Article 10 of the above-mentioned EU Directive, the EU declarations of conformity are available for scrutiny by the authorities responsible by:

Siemens Aktiengesellschaft
Bereich Automatisierungstechnik
AUT E 148
Postfach 1963
D-92209 Amberg

Area of Application

SIMATIC products are designed for use in an industrial environment.

With a special permit, SIMATIC products can also be used in a residential environment (residential, office and trade environments, small businesses). You must obtain the special permit from the appropriate authority or testing agency. In Germany, these special permits are issued by the Bundesamt für Post und Telekommunikation and its regional offices.

Area of Application	Requirement for	
	Interference Emission	Interference Immunity
Industry	EN 50081-2 : 1993	EN 50082-2 : 1995
Residential	Special permit	EN 50082-1 : 1992

Compliance with Installation Guidelines

SIMATIC products satisfy the requirements if you comply with the guidelines for installation and operation as laid down in the manuals.

Recycling and Disposal

The ET 200B distributed I/O station is an environmentally compatible product.

The following are some of the characteristics of ET 200B:

- The plastic used for the housing has high fire resistance deriving from halogen-free flame resistance
- Laser labeling (i.e. no externally applied labels)
- Plastics bear identification markings to DIN 54840
- Compact design so materials outlay is low, number of components is minimized by integration in ASICs

On account of the low pollutant make-up, ET 200B is suitable for recycling.

For environmentally compatible recycling and disposal of your old SIMATIC equipment, please contact:

Siemens Aktiengesellschaft
Technische Dienstleistungen
ANL A 44 Kreislaufwirtschaft
Postfach 32 40
D-D-91052 Erlangen

Phone: + 49 91 31/7-3 33 19

Fax: + 49 91 31/7-2 66 43

This Siemens office offers comprehensive and flexible disposal backed by individual consulting at fixed prices. Once the equipment has been disposed of you receive disassembly records stating the material fractions and the corresponding identification records for the materials.

Digital Modules

7

Introduction

There are a number of digital modules for connecting sensors/transducers or actuators/loads.

In this Chapter

This chapter contains the technical data, the dimensional drawings and the block diagrams for the ET 200B digital modules.

In Section	you will find	on Page
7.1	Digital Modules	7-2
7.2	Terminal Blocks	7-4
7.3	Electronics Blocks	7-14

7.1 Digital Modules

Introduction The tables below provide an overview of the digital modules of ET 200B.

List of Electronics Blocks The following types of digital electronics block are available:

Table 7-1 ET 200B Digital Electronics Blocks

Electronics block	Description
ET 200B-16DI	Inputs: 16 × DC 24 V (3 ms)
ET 200B-32DI	Inputs: 32 × DC 24 V (3 ms)
ET 200B-32DI 0.2ms	Inputs: 32 × DC 24 V (0.2 ms)
ET 200B-16DO	Outputs: 16 × DC 24 V (0.5 A/2 A)
ET 200B-16DO/2A	Outputs: 16 × DC 24 V (2 A)
ET 200B-32DO	Outputs: 32 × DC 24 V (0.5 A)
ET 200B-8DI/8DO	Inputs: 8 × DC 24 V (3 ms) Outputs: 8 × DC 24 V (0.5 A)
ET 200B-8DI/8DO HWA	Inputs: 8 × DC 24 V (3 ms) Outputs: 8 × DC 24 V (0.5 A)/HW shutdown
ET 200B-16DI/16DO	Inputs: 16 × DC 24 V (3 ms) Outputs: 16 × DC 24 V (0.5 A)
ET200B-24DI/8DO	Inputs: 24 × DC 24 V (3 ms) Outputs: 8 × DC 24 V (0.5 A)
ET200B-24DI/8DO 0.2ms	Inputs: 24 × DC 24 V (0.2 ms) Outputs: 8 × DC 24 V (0.5 A)
ET 200B-8RO	Outputs: 8 × REL. DC 24 ... 60 V
ET 200B-16DI-AC	Inputs: 16 × AC 120/230 V
ET 200B-16DO-AC	Outputs: 16 × AC 120/230 V (0.5 A)
ET 200B-16RO-AC	Outputs: 16 × REL. AC 120 V/DC 24 ... 150 V
ET 200B-8DI/8RO-AC	Inputs: 8 × AC 120/230 V Outputs: 8 × REL. AC 120 V/DC 24 ... 150 V

List of Terminal Blocks

The following types of digital terminal blocks are available:

Table 7-2 ET 200B Digital Terminal Blocks

Terminal block	Description
TB1/DC	16-channel, screw-type terminal, 3-tier
TB1-4/DC	16-channel, screw-type terminal, 4-tier
TB2/DC	32-channel, screw-type terminal, 3-tier
TB2-4/DC	32-channel, screw-type terminal, 4-tier
TB3/DC	16-channel, spring-latch terminal
TB4/DC	32-channel, spring-latch terminal
TB4M/DC	32-channel, spring-latch terminal with extra row of terminals for additional grounds
TB6/AC	16-channel, screw-type terminal, 3-tier

7.2 Terminal Blocks

Introduction This section contains the dimensional drawings and the terminal numbering of the ET 200B terminal blocks

The last subsection shows the dimensions of an ET 200B station with bus connector inserted.

Pin Assignment The pin assignment of the terminal blocks depends on which electronics block is installed and is therefore described in the section dealing with electronics blocks, Section 7.3.

In this Section

In Section	you will find	on Page
7.2.1	Terminal block TB1/DC (6ES7 193-0CA10-0XA0)	7-5
7.2.2	Terminal block TB1-4/DC (6ES7 193-0CA20-0XA0)	7-6
7.2.3	Terminal block TB3/DC (6ES7 193-0CA30-0XA0)	7-7
7.2.4	Terminal block TB2/DC (6ES7 193-0CB10-0XA0)	7-8
7.2.5	Terminal block TB2-4/DC (6ES7 193-0CB20-0XA0)	7-9
7.2.6	Terminal block TB4/DC (6ES7 193-0CB30-0XA0)	7-10
7.2.7	Terminal block TB4M/DC (6ES7 193-0CE30-0XA0)	7-11
7.2.8	Terminal block TB6/AC (6ES7 193-0CC10-0XA0)	7-12
7.2.9	Terminal block and bus connector	7-13

7.2.1 Terminal Block TB1/DC (6ES7 193-0CA10-0XA0)

Dimensional Drawing

Figure 7-1 is a dimensional drawing of the TB1/DC (screw-type terminal, 3-tier).

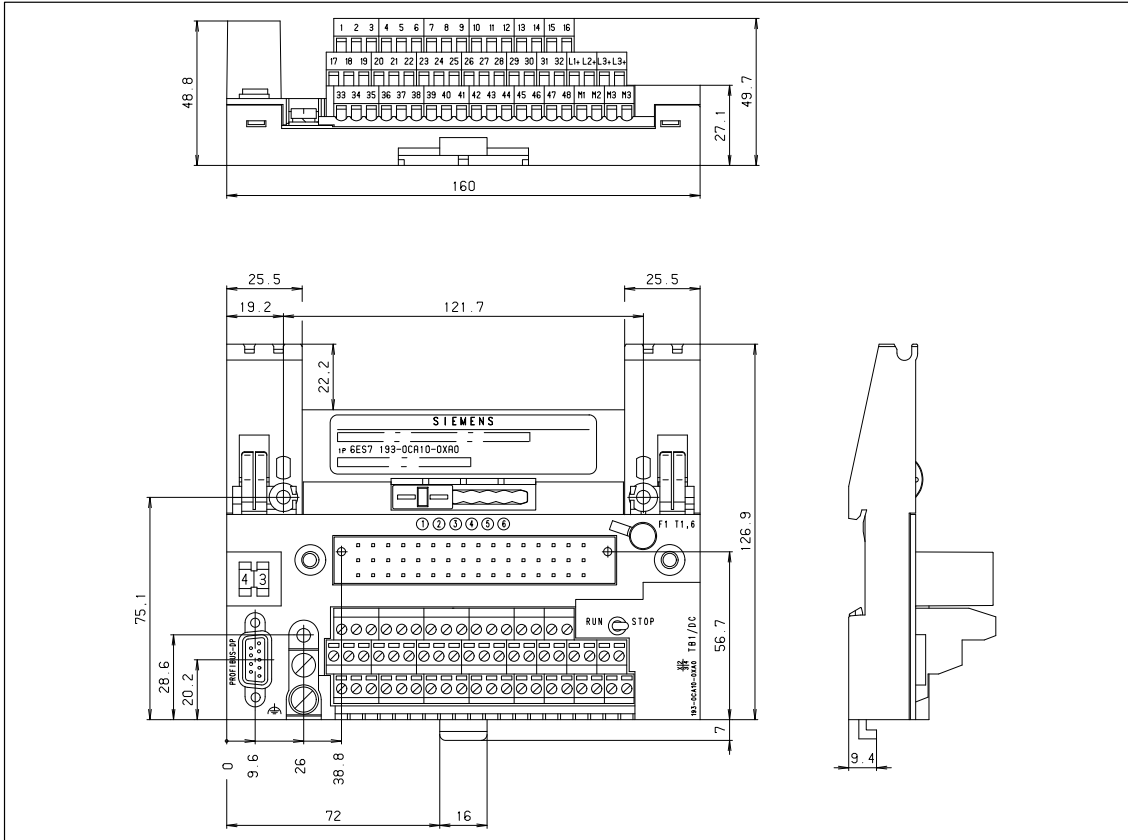

Figure 7-1 Dimensional Drawing: Terminal Block TB1/DC (Screw-Type Terminal, 3-Tier)

Terminal Numbering

Figure 7-2 is an enlargement of the terminal numbering printed on the TB1/DC (screw-type terminal, 3-tier).

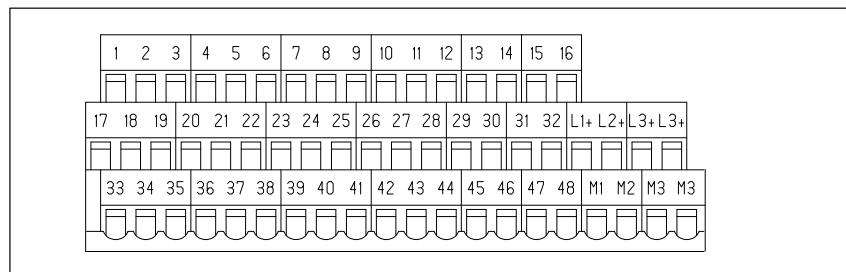

Figure 7-2 Terminal Numbering: Terminal Block TB1/DC (Screw-Type Terminal, 3-Tier)

7.2.2 Terminal Block TB1-4/DC (6ES7 193-0CA20-0XA0)

Dimensional Drawing

Figure 7-3 is a dimensional drawing of the TB1-4/DC (screw-type terminal, 4-tier).

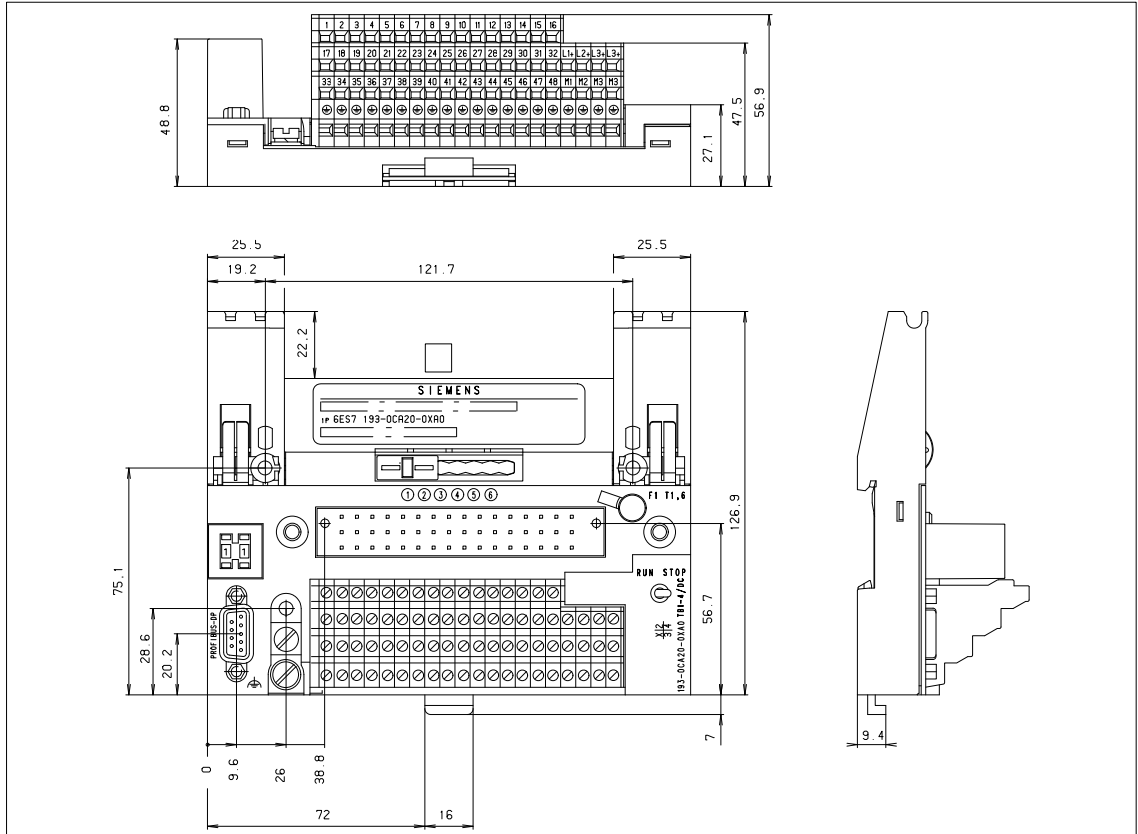

Figure 7-3 Dimensional Drawing: Terminal Block TB1-4/DC (Screw-Type Terminal, 4-Tier)

Terminal Numbering

Figure 7-4 is an enlargement of the terminal numbering printed on the TB1-4/DC (screw-type terminal, 4-tier).

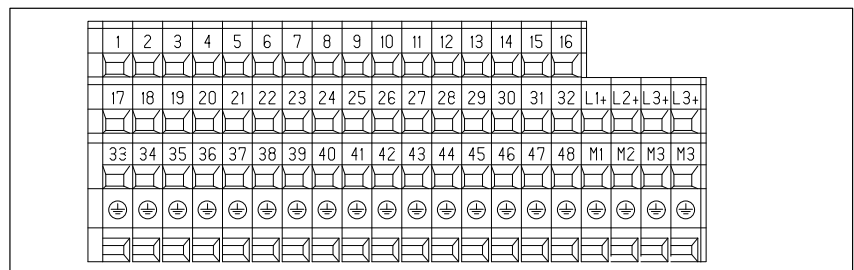

Figure 7-4 Terminal Numbering: Terminal Block TB1-4/DC (Screw-Type Terminal, 4-Tier)

7.2.3 Terminal Block TB3/DC (6ES7 193-0CA30-0XA0)

Dimensional Drawing Figure 7-5 is a dimensional drawing of the TB3/DC (spring-latch terminal).

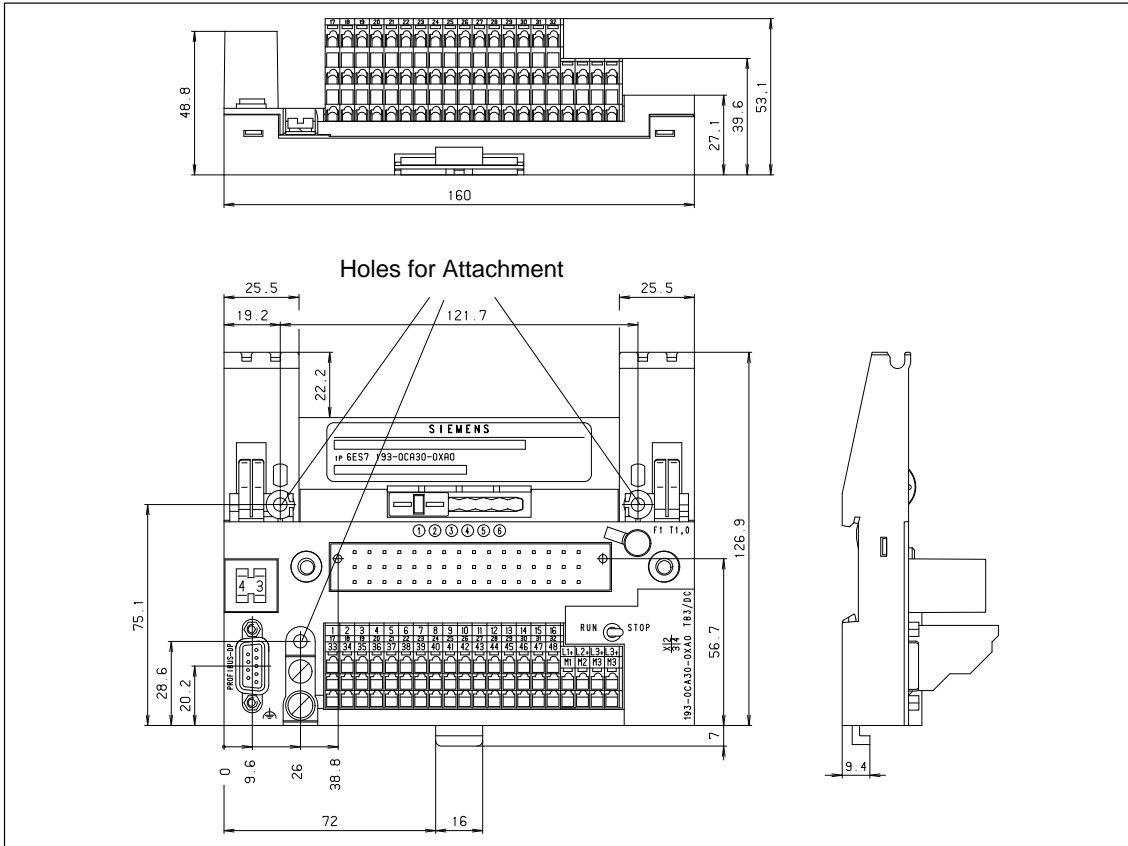

Figure 7-5 Dimensional Drawing: Terminal Block TB3/DC (Spring-Latch Terminal)

Terminal Numbering Figure 7-6 is an enlargement of the terminal numbering printed on the TB3/DC (spring-latch terminal).

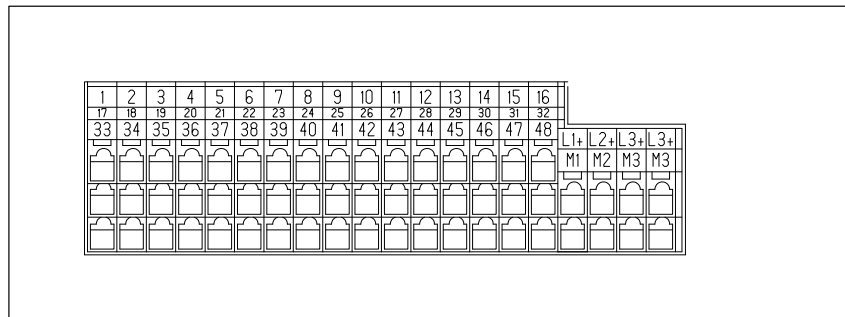

Figure 7-6 Terminal Numbering: Terminal Block TB3/DC (Spring-Latch Terminal)

7.2.4 Terminal Block TB2/DC (6ES7 193-0CB10-0XA0)

Dimensional Drawing

Figure 7-7 is a dimensional drawing of the TB2/DC (screw-type terminal, 3-tier).

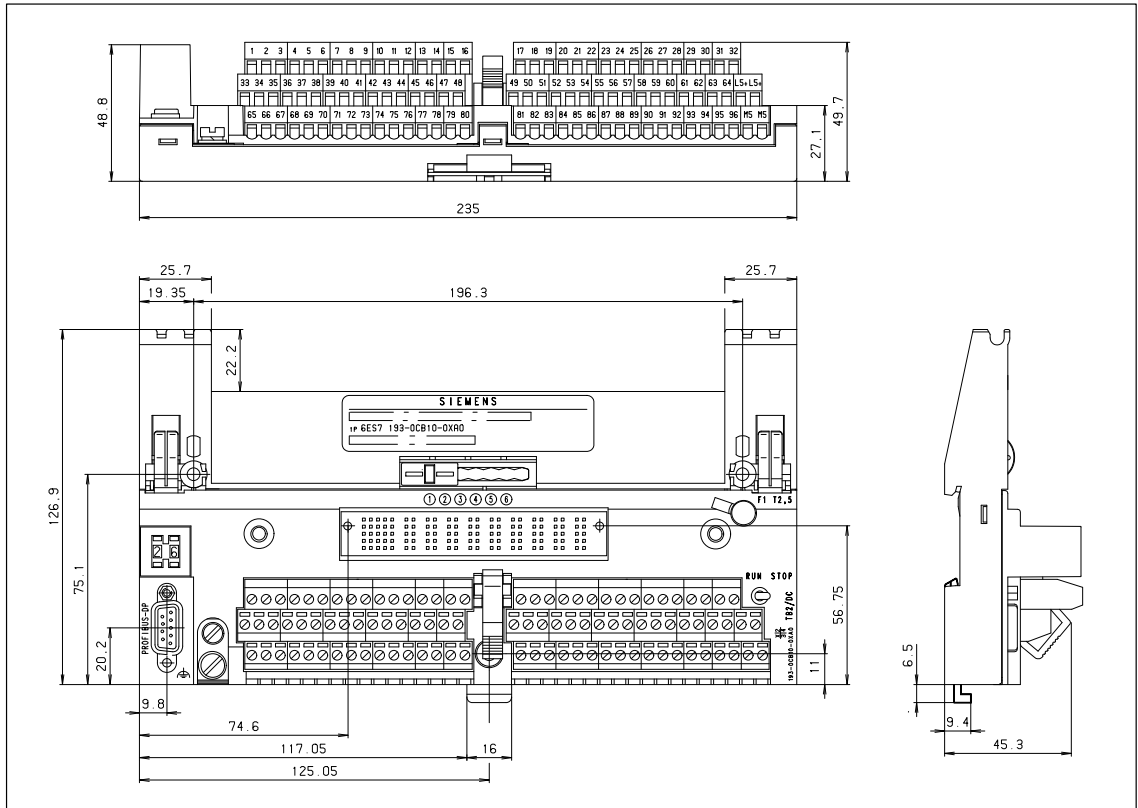

Figure 7-7 Dimensional Drawing: Terminal Block TB2/DC (Screw-Type Terminal, 3-Tier)

Terminal Numbering

Figure 7-8 is an enlargement of the terminal numbering printed on the TB2/DC (screw-type terminal, 3-tier).

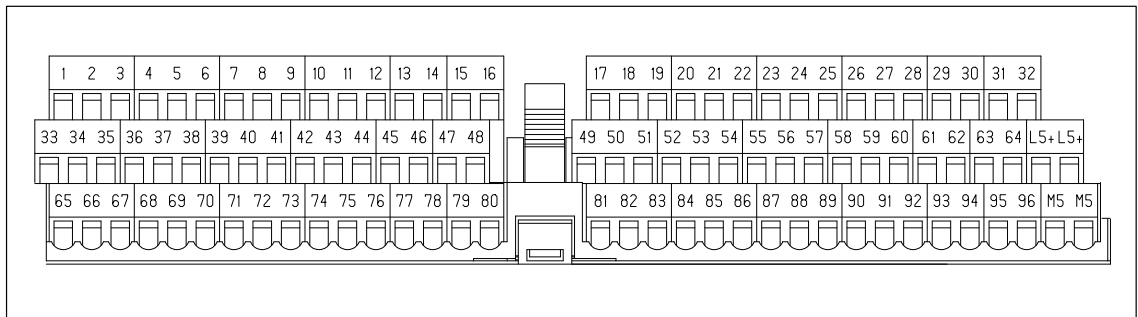

Figure 7-8 Terminal Numbering: Terminal Block TB2/DC (Screw-Type Terminal, 3-Tier)

7.2.5 Terminal Block TB2-4/DC (6ES7 193-0CB20-0XA0)

Dimensional Drawing

Figure 7-9 is a dimensional drawing of the TB2-4/DC (screw-type terminal, 4-tier).

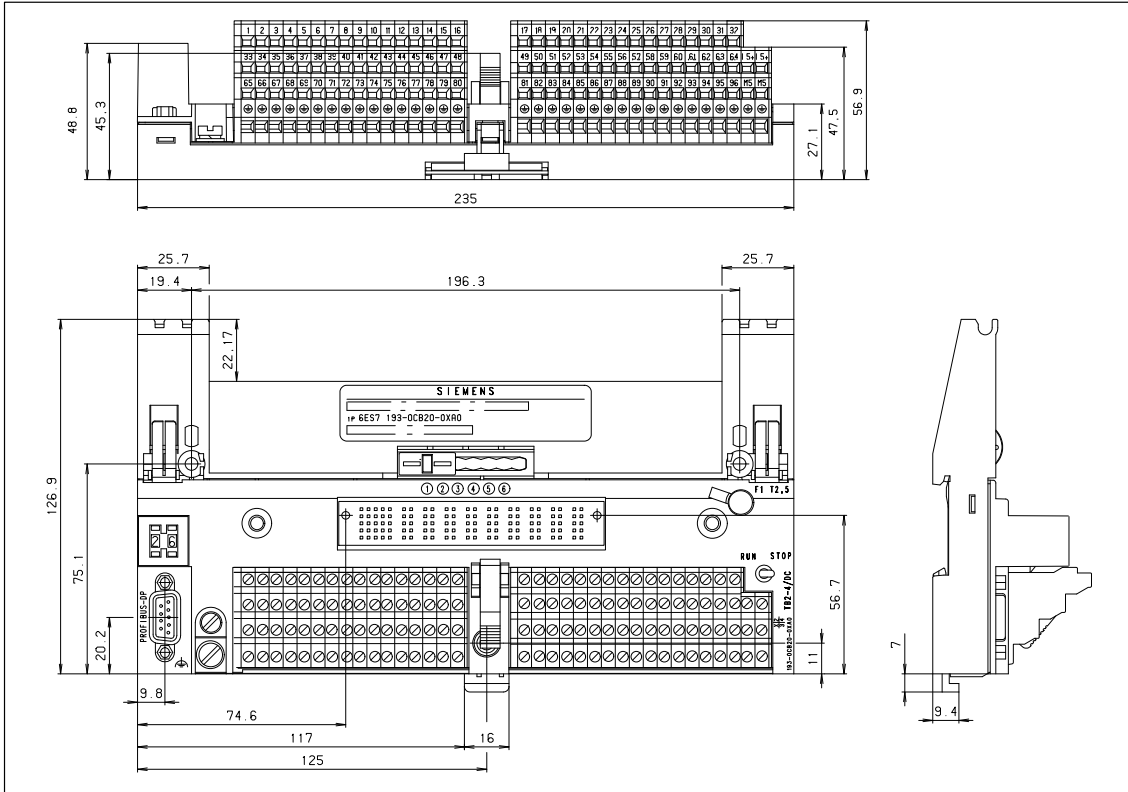

Figure 7-9 Dimensional Drawing: Terminal Block TB2-4/DC (Screw-Type Terminal, 4-Tier)

Terminal Numbering

Figure 7-10 is an enlargement of the terminal numbering printed on the TB2-4/DC (screw-type terminal, 4-tier).

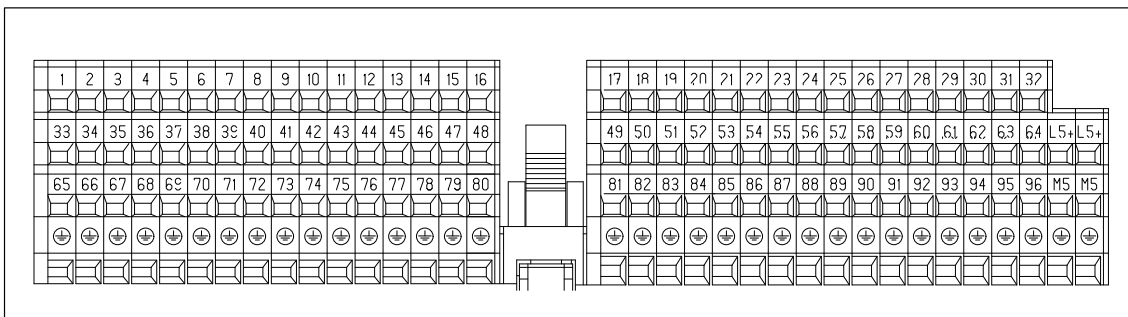

Figure 7-10 Terminal Numbering: Terminal Block TB2-4/DC (Screw-Type Terminal, 4-Tier)

7.2.6 Terminal Block TB4/DC (6ES7 193-0CB30-0XA0)

Dimensional Drawing Figure 7-11 is a dimensional drawing of the TB4/DC (spring-latch terminal).

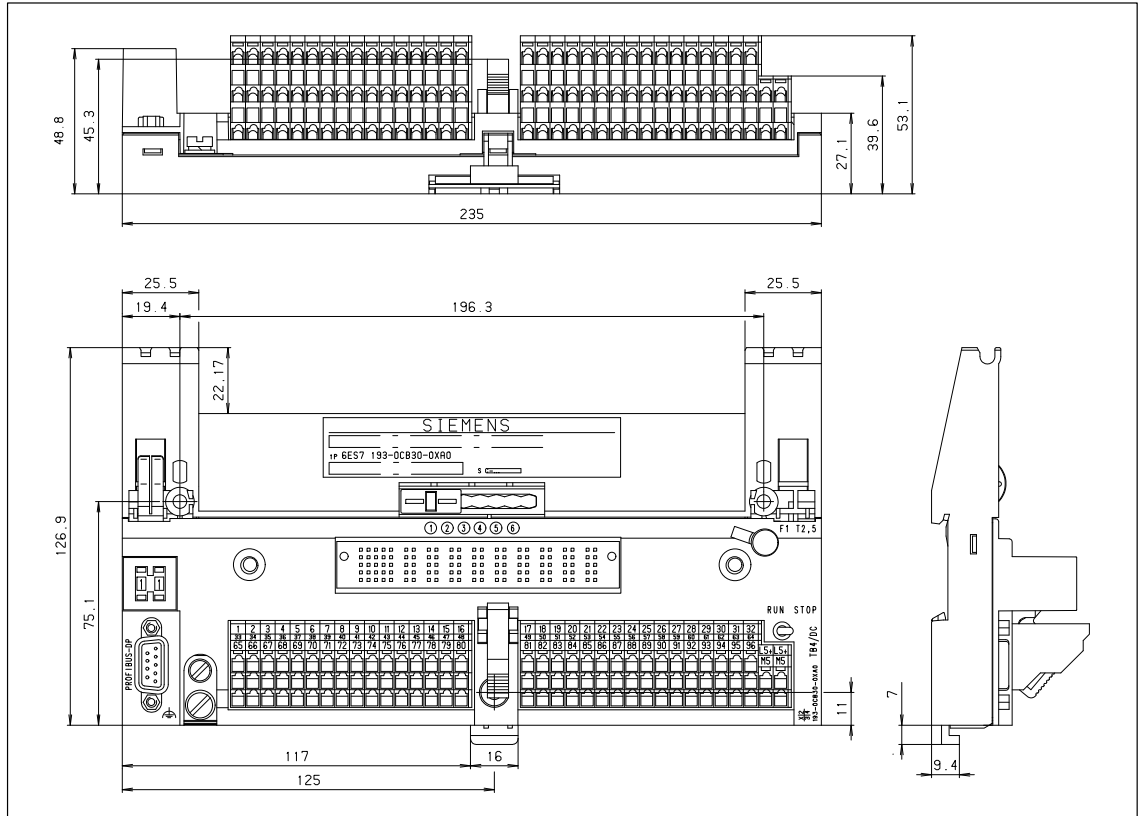

Figure 7-11 Dimensional Drawing: Terminal Block TB4/DC (Spring-Latch Terminal)

Terminal Numbering Figure 7-12 is an enlargement of the terminal numbering printed on the TB4/DC (spring-latch terminal).

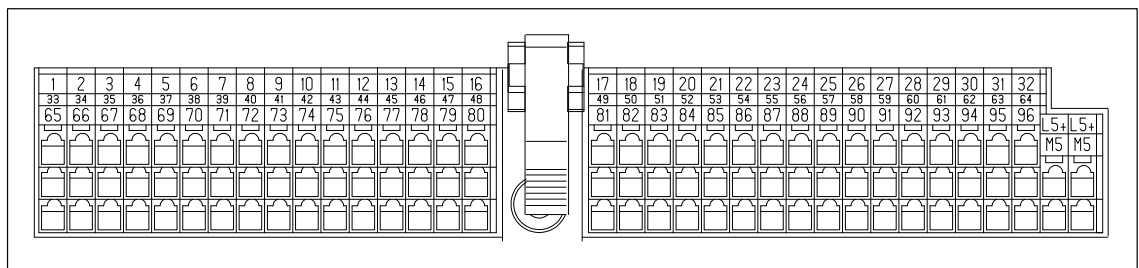

Figure 7-12 Terminal Numbering: Terminal Block TB4/DC (Spring-Latch Terminal)

7.2.7 Terminal Block TB4M/DC (6ES7 193-0CE30-0XA0)

Dimensional Drawing Figure 7-13 is a dimensional drawing of the TB4M/DC (spring-latch terminal).

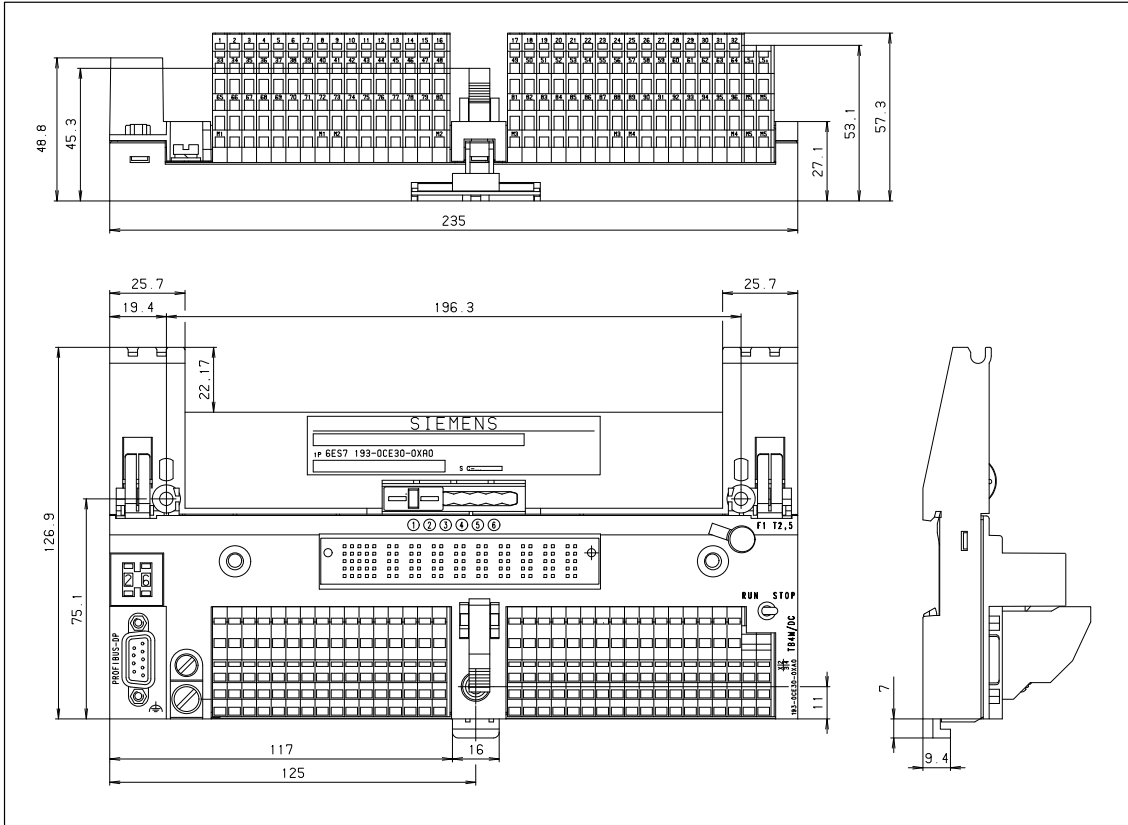

Figure 7-13 Dimensional Drawing: Terminal Block TB4M/DC (Spring-Latch Terminal)

Terminal Numbering Figure 7-14 is an enlargement of the terminal numbering printed on the TB4M/DC (spring-latch terminal).

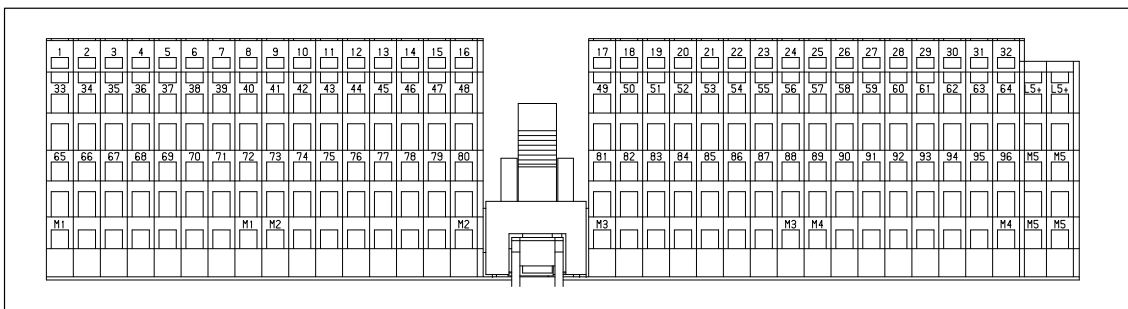

Figure 7-14 Terminal Numbering: Terminal Block TB4M/DC (Spring-Latch Terminal)

7.2.8 Terminal Block TB6/AC (6ES7 193-0CC10-0XA0)

Dimensional Drawing Figure 7-15 is a dimensional drawing of the TB6/AC (screw-type terminal, 3-tier)

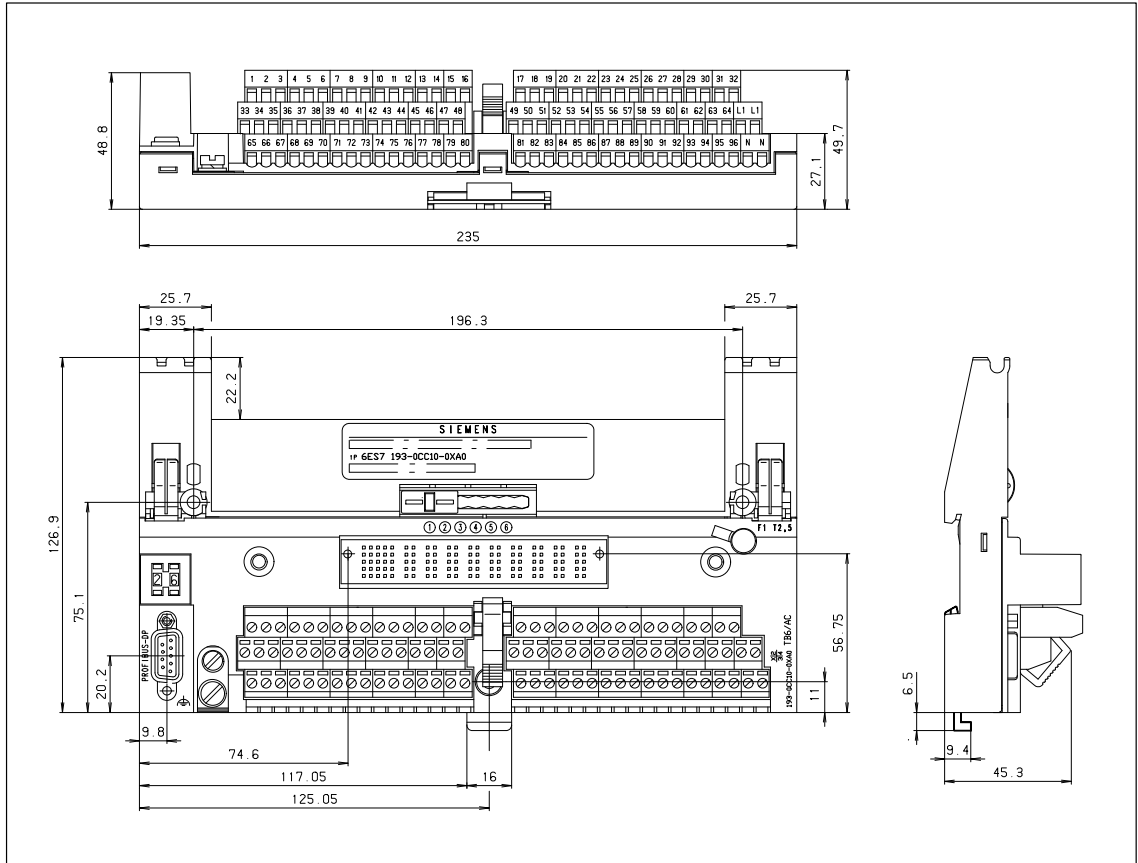

Figure 7-15 Dimensional Drawing: Terminal Block TB6/AC (Screw-Type Terminal, 3-Tier)

Terminal Numbering Figure 7-16 is an enlargement of the terminal numbering printed on the TB6/AC (screw-type terminal, 3-tier).

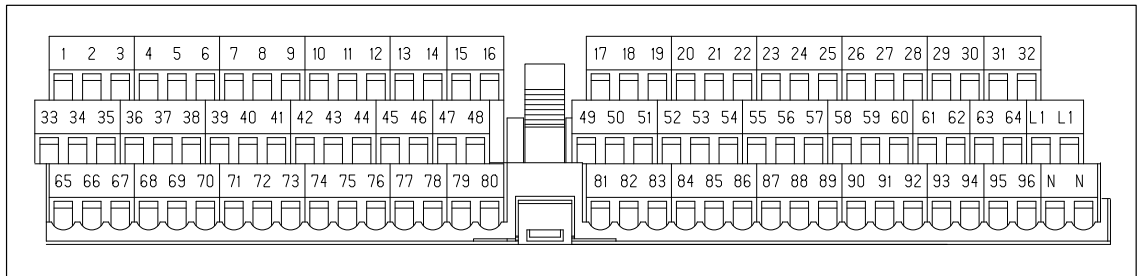

Figure 7-16 Terminal Numbering: Terminal Block TB6/AC (Screw-Type Terminal, 3-Tier)

7.2.9 Terminal Block and Bus Connector

Dimensional Drawing Figure 7-17 shows the dimensional drawings (side elevation) of any terminal block with electronics block inserted and a variety of bus connectors.

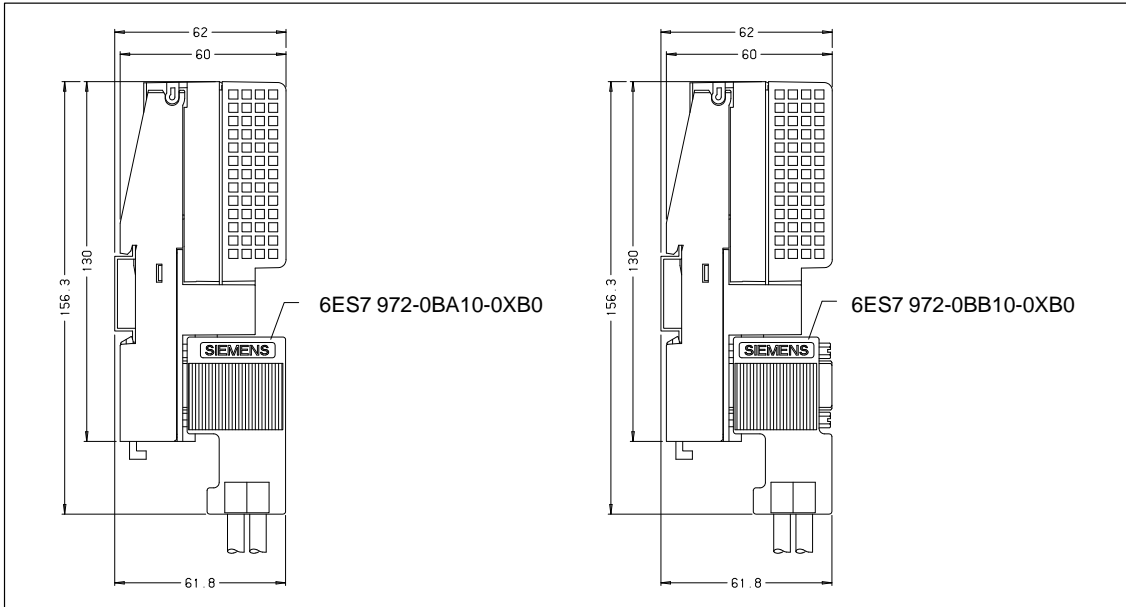

Figure 7-17 Dimensional Drawing: Side Elevation with Bus Connector (6ES7 972-0BA10-0XA0 and 6ES7 972-0BB10-0XA0)

7.3 Electronics Blocks

Introduction

This section contains the technical data of the electronics blocks of ET 200B.

The technical data for each electronics block is accompanied by

- an outline of the characteristics,
- the block diagram and
- the pin assignments for the various permissible terminal blocks.

In this Section

In Section	you will find	on Page
7.3.1	ET 200B-16DI (6ES7 131-0BH00-0XB0)	7-15
7.3.2	ET 200B-32DI (6ES7 131-0BL00-0XB0) and ET 200B-32DI 0.2ms (6ES7 131-0BL10-0XB0)	7-20
7.3.3	ET 200B-16DO (6ES7 132-0BH01-0XB0)	7-26
7.3.4	ET 200B-16DO/2A (6ES7 132-0BH11-0XB0)	7-32
7.3.5	ET 200B-32DO (6ES7 132-0BL01-0XB0)	7-38
7.3.6	ET 200B-8RO (6ES7 132-0GF00-0XB0)	7-44
7.3.7	ET 200B-8DI/8DO (6ES7 133-0BH01-0XB0)	7-49
7.3.8	ET 200B-8DI/8DO HWA (6ES7 133-0BH10-0XB0)	7-55
7.3.9	ET 200B-16DI/16DO (6ES7 133-0BL00-0XB0)	7-62
7.3.10	ET 200B-24DI/8DO (6ES7 133-0BN01-0XB0) and ET 200B-24DI/8DO 0.2ms (6ES7 133-0BN11-0XB0)	7-68
7.3.11	ET 200B-16DI-AC (6ES7 131-0HF00-0XB0)	7-74
7.3.12	ET 200B-16DO-AC (6ES7 132-0HF00-0XB0)	7-79
7.3.13	ET 200B-16RO-AC (6ES7 132-0HH00-0XB0)	7-84
7.3.14	ET 200B-8DI/8RO-AC (6ES7 133-0HH00-0XB0)	7-89

7.3.1 Electronics Block ET 200B-16DI (6ES7 131-0BH00-0XB0)

Characteristics

The ET 200B 16DI electronics block has the following characteristics

- 16 inputs, non-floating
- Input voltage: 24 V DC
- Suitable for switches and 2/3-wire proximity switches (BEROs).
- Possible terminal blocks: TB1/DC, TB1-4/DC, TB3/DC

Dimensional Drawing

Dimensional drawing for ET 200B-16DI:

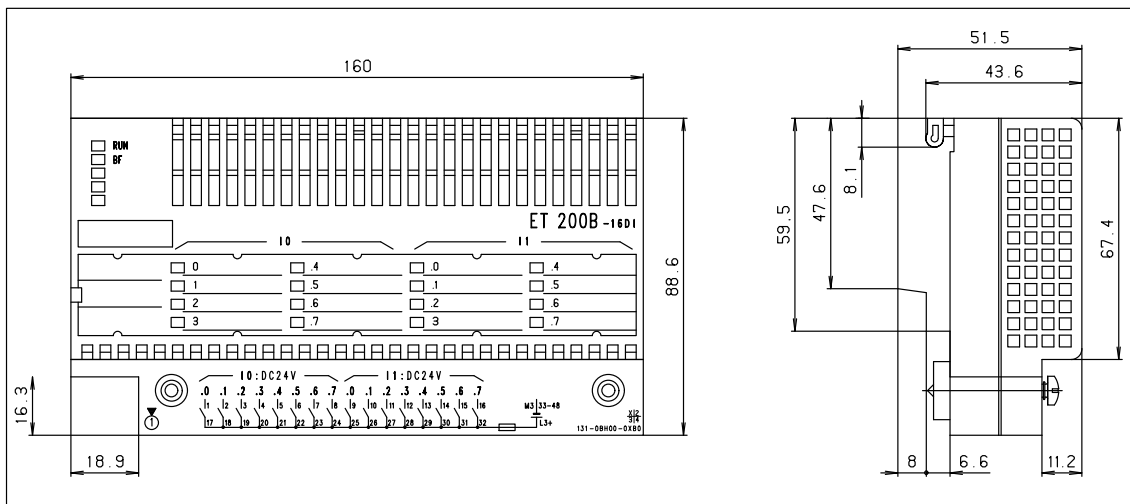

Figure 7-18 Dimensional Drawing: ET 200B-16DI (6ES7 131-0BH00-0XB0)

Terminal Numbering

Figure 7-19 is an enlargement of the terminal numbering printed on the ET 200B-16DI.

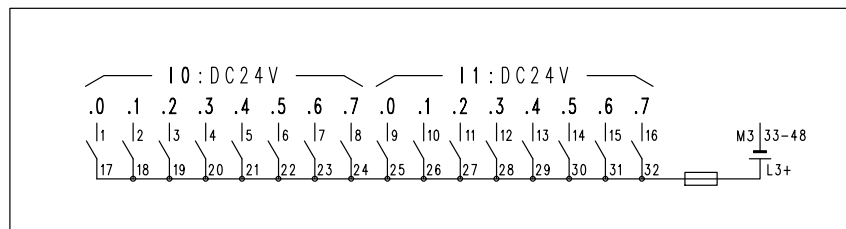

Figure 7-19 Connection Diagram: ET 200B-16DI (6ES7 131 0BH00-0XB0)

Block Diagram Simplified diagram of potential for the ET 200B-16DI and TB1/DC or TB3/DC:

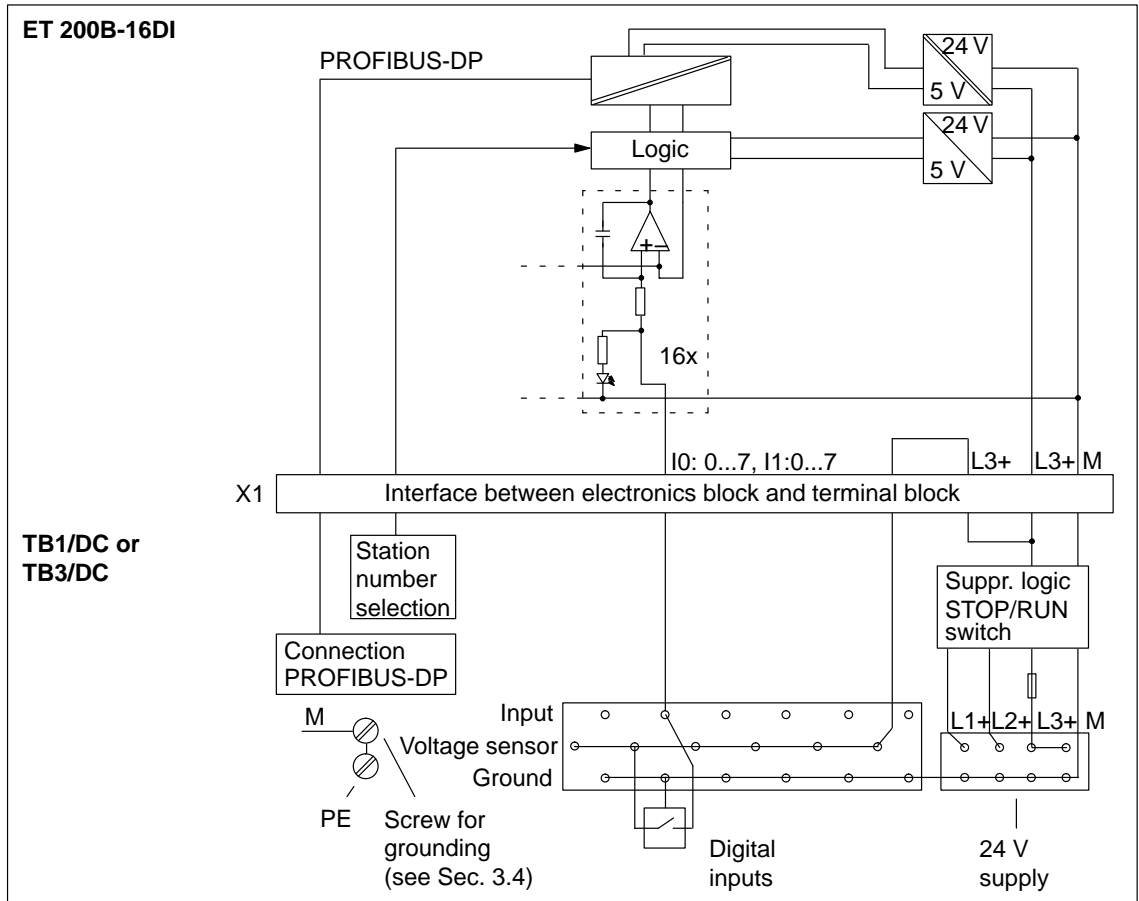

Figure 7-20 Block Diagram: ET 200B-16DI (6ES7 131-0BH0-0XB0) and TB1/DC or TB3/DC

Block Diagram

Simplified diagram of the potential for the ET 200B-16DI and TB1-4/DC:

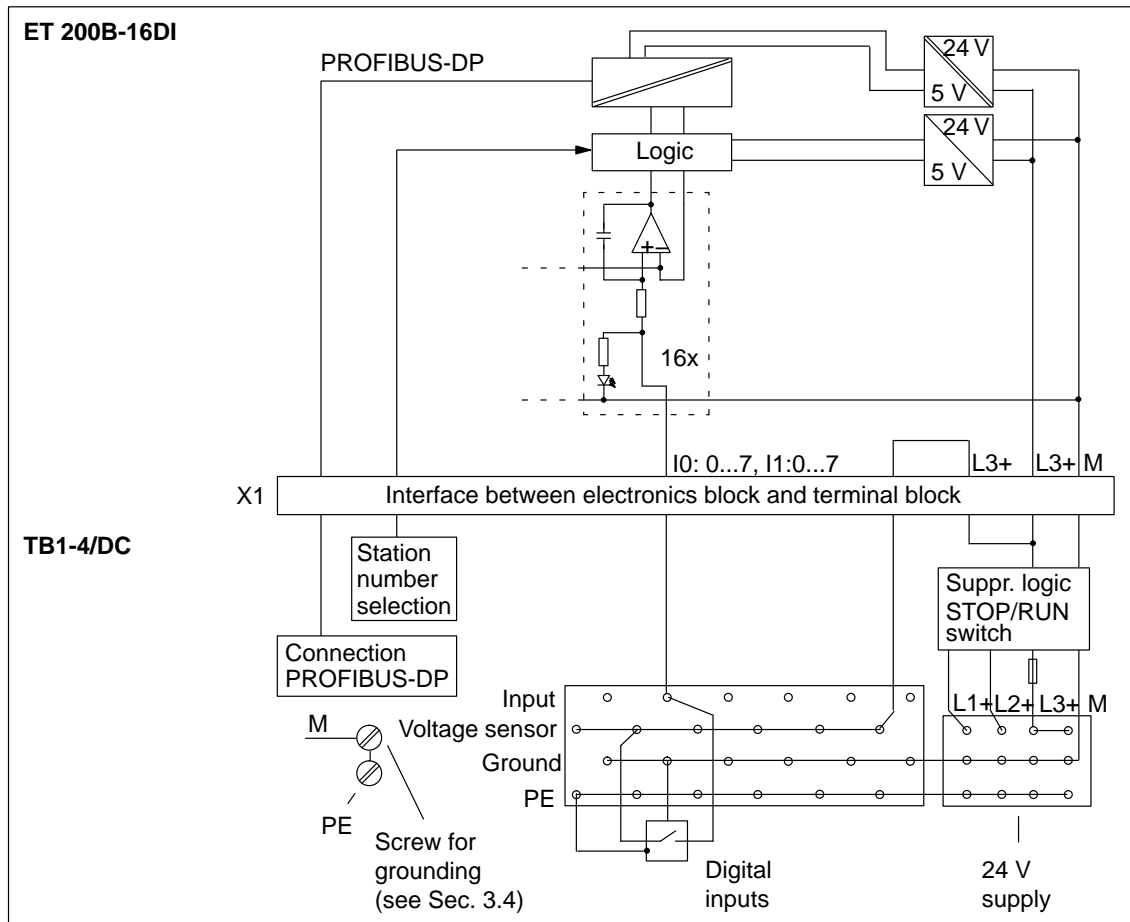

Figure 7-21 Block Diagram: ET 200B-16DI (6ES7 131-0BH00-0XB0) and TB1-4/DC

Pin Assignment

The table below shows the pin assignment of the terminal blocks for ET 200B-16DI. For the sake of clarity, the table also shows the terminal numbering of the terminal blocks, taking the TB1-4/DC by way of example.

Table 7-3 Pin Assignment of Terminal Blocks TB1/DC; TB1-4/DC and TB3/DC for ET 200B-16DI (6ES7 131-0BH00-0XB0)

Terminal tier 1		Terminal tier 2		Terminal tier 3		Terminal tier 4 ¹	
1	I0: Input .0	17	24 V (sensor voltage, internally jumpered, connected to L3+)	33	Ground (sensor voltage, internally jumpered, connected to M1, M2, M3)	⊕	PE (internally jumpered, but not connected to PE screw)
2	I0: Input .1	18		34		⊕	
3	I0: Input .2	19		35		⊕	
4	I0: Input .3	20		36		⊕	
5	I0: Input .4	21		37		⊕	
6	I0: Input .5	22		38		⊕	
7	I0: Input .6	23		39		⊕	
8	I0: Input .7	24		40		⊕	
9	I1: Input .0	25		41		⊕	
10	I1: Input .1	26		42		⊕	
11	I1: Input .2	27		43		⊕	
12	I1: Input .3	28		44		⊕	
13	I1: Input .4	29		45		⊕	
14	I1: Input .5	30		46		⊕	
15	I1: Input .6	31		47		⊕	
16	I1: Input .7	32		48		⊕	
-		L1+	not used	M1	not used	⊕	PE (internally jumpered, but not connected to PE screw)
-		L2+	not used	M2	not used	⊕	
-		L3+	Voltage supply, internal logic and sensor voltage 24 V	M3	Ground connection, internal logic and sensor voltage	⊕	
-		L3+	Voltage supply, internal logic and sensor voltage 24 V	M3	Ground connection, internal logic and sensor voltage	⊕	

1 TB1-4/DC only

Important Note on Wiring

The following notes are important as regards the wiring of the ET 200B-16DI:

- The terminals for PE on the 4-tier terminal block are not connected to the PE connection of terminal block TB1-4/DC.
- L3+ and terminals 17 ... 32 are interconnected, as are M1, M2, M3 and terminals 33 ... 48.
- The two L3+ terminals are also interconnected.

Fuse

The 24 V sensor supply is protected by fuse F1 (1.6 A) in the terminal blocks. Nevertheless, make sure that the current does not exceed the specifications in the technical data for the electronics block.

Technical Data

The technical data of electronics block ET 200B-16DI is listed in the tables below.

Technical specifications		Inputs	
Baud rates*	9.6/19.2/93.75/187.5/500/1500/3000/6000/12000 kbaud	Number of inputs	16
Bus protocol	PROFIBUS-DP	Galvanic isolation to internal electronic circuits	No
FREEZE capability	Yes	Input voltage	
Galvanic isolation to SI-NEC L2-DP	Yes	• Rated value	24 V DC
Power losses	Typ. 2.5 W	• For "0" signal	- 30 V to 5 V
Weight (EB and TB)	Approx. 600 g (21 oz.)	• For "1" signal	13 V to 30 V
Dimensions (EB and TB: W × H × D)	160 × 130 × 60 mm (6.24 x 5.07 x 2.34 in.)	Input current for "1" signal	Typ. 4 mA at 24 V Min. 2 mA
Diagnostics functions		Delay of inputs	2.0 to 3.5 ms
Voltage monitoring	Green "RUN" LED	Connection of 2-wire BERO	Possible
Bus monitoring SI-NEC L2-DP	Red "BF" LED	• Quiescent current	≤ 1.5 mA
Status of inputs	Green LEDs	Connection of mechanical switches	Possible
Supply voltage for inputs, sensor supply and internal logic		Wire lengths of the sensors	
Supply voltage (L3+)		• Unshielded	Max. 100 m (328 ft.)
• Rated value	24 V DC	* In operation with the IM 308-B, the maximum baud rate is 1500 kbaud.	
• Permissible range	18.5 to 30.2 V		
• Value for t < 0.5 s	35 V		
Current consumption from L3+			
• Logic	Typ. 70 mA		
• Sensors	Max. 500 mA		
I ² t (for inrush current)	≤ 0.05 A ² s		

7.3.2 Electronics Blocks ET 200B-32DI (6ES7 131-0BL00-0XB0) and ET 200B-32DI 0.2ms (6ES7 131-0BL10-0XB0)

Characteristics

The ET 200B-32DI and ET 200B-32DI 0.2ms electronics blocks have the following characteristics:

- 32 inputs, non-floating
- Input voltage: 24 V DC
- Input delay:
 - 6ES7 131-0BL00-0XB0 → 3 ms
 - 6ES7 131-0BL10-0XB0 → 0.2 ms
- Suitable for switches and 2/3-wire proximity switches (BEROs).
- Possible terminal blocks: TB2/DC, TB2-4/DC, TB4/DC, TB4M/DC

Dimensional Drawing

Dimensional drawing for ET 200B-32DI (6ES7 131-0BL00-0XB0) and ET 200B-32DI 0.2ms (6ES7 131-0BL10-0XB0):

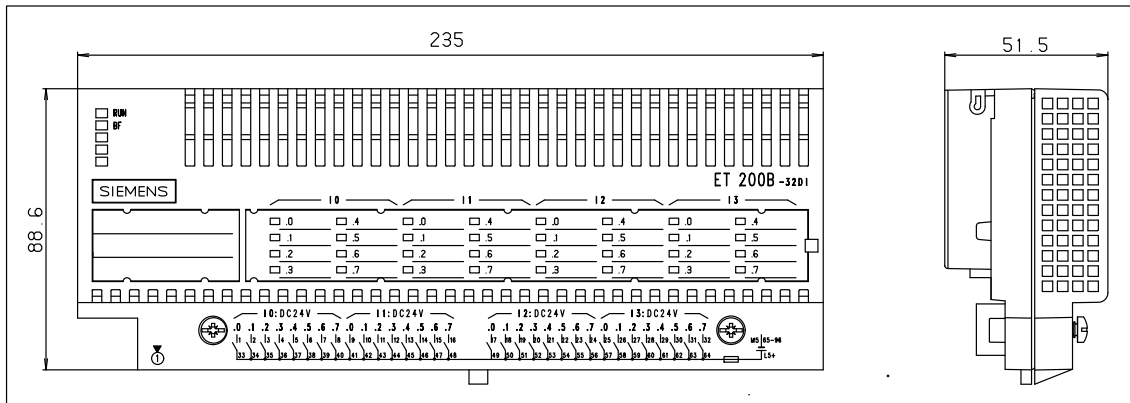

Figure 7-22 Dimensional Drawing: ET 200B-32DI (6ES7 131-0BL00-0XB0) and ET 200B-32DI 0.2ms (6ES7 131-0BL10-0XB0)

Terminal Numbering

Figure 7-23 is an enlargement of the terminal numbering printed on the ET 200B-32DI.

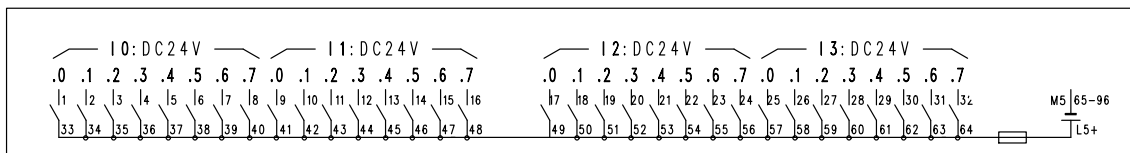

Figure 7-23 Connection Diagram: ET 200B-32DI (6ES7 131-0BL00-0XB0) and ET 200B-32DI 0.2ms (6ES7 131-0BL10-0XB0)

Block Diagram

Simplified diagram of potential for the ET 200B-32DI or ET 200B-32DI 0.2 ms and TB2/DC or TB4/DC:

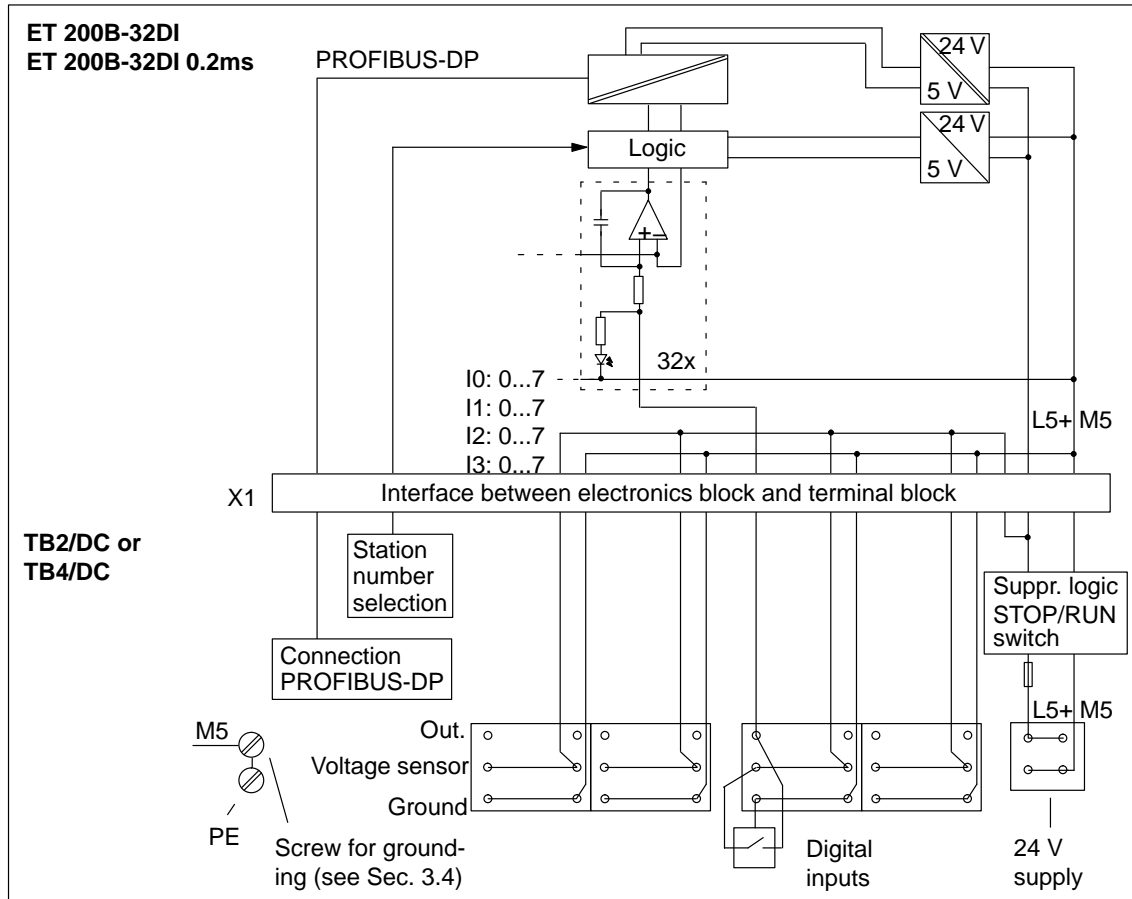

Figure 7-24 Block Diagram: ET 200B-32DI (6ES7 131-0BL00-0XB0) or ET 200B-32DI 0.2ms (6ES7 131-0BL10-0XB0) and TB2/DC or TB4/DC

Block Diagram

Simplified diagram of the potential for the ET 200B-32DI or ET 200B-32DI 0.2 ms and TB2-4/DC:

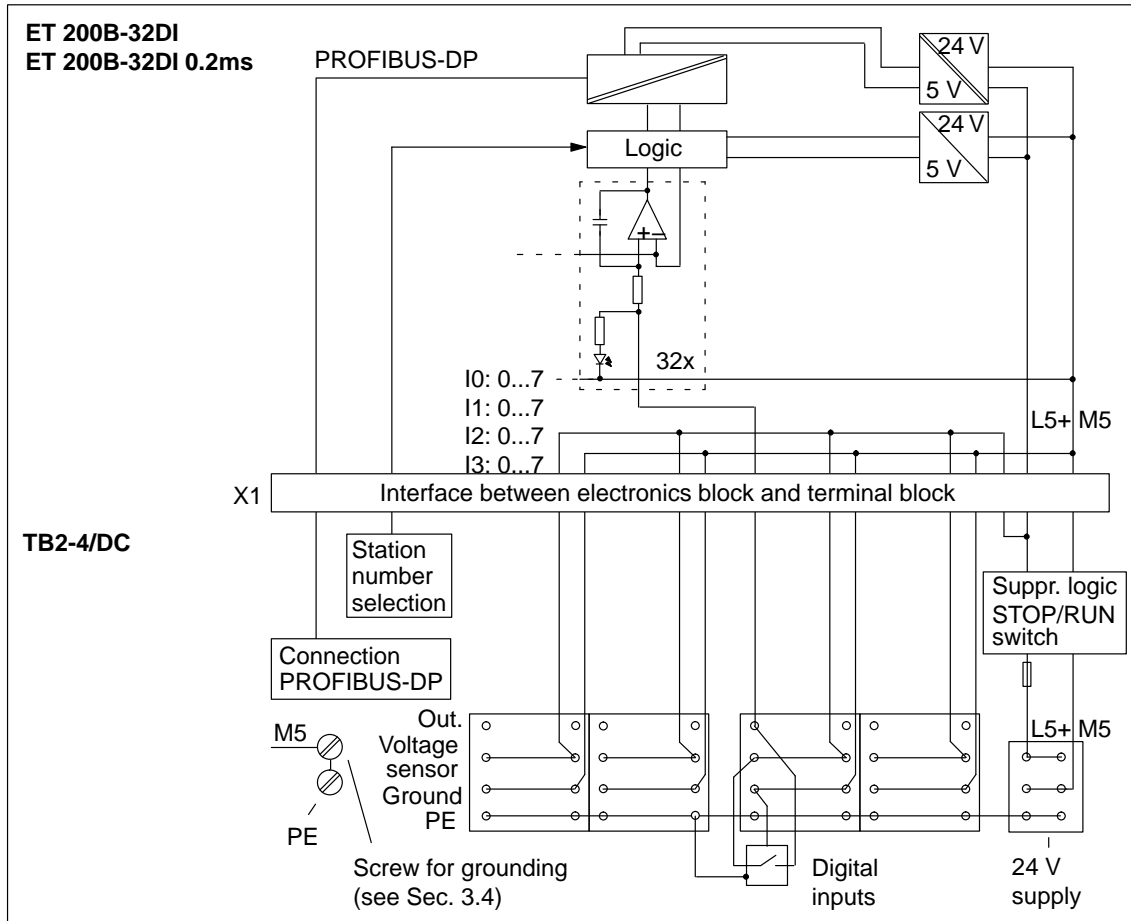

Figure 7-25 Block Diagram: ET 200B-32DI (6ES7 131-0BL00-0XB0) or ET 200B-32DI 0.2ms (6ES7 131-0BL10-0XB0) and TB2-4/DC

Pin Assignment

The table below shows the pin assignment of the terminal blocks for ET 200B-32DI and ET 200B-32DI 0.2 ms. For the sake of clarity, the table also shows the terminal numbering of the terminal blocks, taking the TB2-4/DC by way of example.

Table 7-4 Pin Assignment of Terminal Blocks TB2/DC, TB2-4/DC, TB4/DC and TB4M/DC for ET 200B-32DI (6ES7 131-0BL00-0XB0) and ET 200B-32DI 0.2ms (6ES7 131-0BL10-0XB0)

Terminal tier 1		Terminal tier 2		Terminal tier 3		Terminal tier 4 ¹	
1	I0: Input .0	33	24 V (sensor voltage, internally jumpered, connected to L5+)	65	Ground (sensor voltage, internally jumpered, connected to M5)	⊕	PE (internally jumpered, but not connected to PE screw)
2	I0: Input .1	34		66		⊕	
3	I0: Input .2	35		67		⊕	
4	I0: Input .3	36		68		⊕	
5	I0: Input .4	37		69		⊕	
6	I0: Input .5	38		70		⊕	
7	I0: Input .6	39		71		⊕	
8	I0: Input .7	40		72		⊕	
9	I1: Input .0	41		73		⊕	
10	I1: Input .1	42		74		⊕	
11	I1: Input .2	43		75		⊕	
12	I1: Input .3	44		76		⊕	
13	I1: Input .4	45		77		⊕	
14	I1: Input .5	46		78		⊕	
15	I1: Input .6	47		79		⊕	
16	I1: Input .7	48		80		⊕	
17	I2: Input .0	49		81		⊕	
18	I2: Input .1	50		82		⊕	
19	I2: Input .2	51		83		⊕	
20	I2: Input .3	52		84		⊕	
21	I2: Input .4	53		85		⊕	
22	I2: Input .5	54		86		⊕	
23	I2: Input .6	55		87		⊕	

Terminal numbering TB2-4/DC

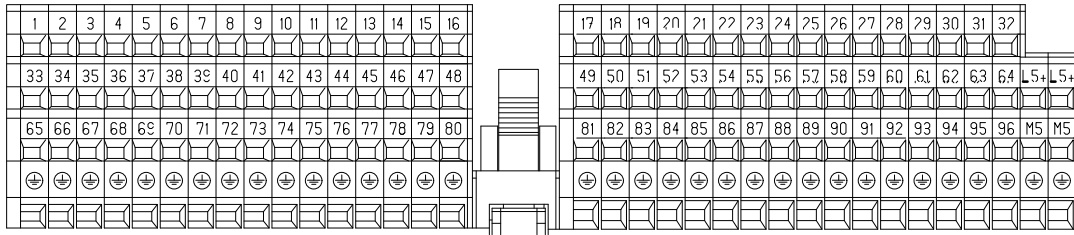

Table 7-4 Pin Assignment of Terminal Blocks TB2/DC, TB2-4/DC, TB4/DC and TB4M/DC for ET 200B-32DI (6ES7 131-0BL00-0XB0) and ET 200B-32DI 0.2ms (6ES7 131-0BL10-0XB0), continued

Terminal tier 1		Terminal tier 2		Terminal tier 3		Terminal tier 4 ¹	
24	I2: Input .7	56	24 V (sensor voltage, internally jumpered, connected to L5+)	88	Ground (sensor voltage, internally jumpered, connected to M5)	⊕	PE (internally jumpered, but not connected to PE screw)
25	I3: Input .0	57		89		⊕	
26	I3: Input .1	58		90		⊕	
27	I3: Input .2	59		91		⊕	
28	I3: Input .3	60		92		⊕	
29	I3: Input .4	61		93		⊕	
30	I3: Input .5	62		94		⊕	
31	I3: Input .6	63		95		⊕	
32	I3: Input .7	64		96		⊕	
–		L5+	Voltage supply, internal logic and sensor voltage 24 V	M5	Ground connection, internal logic and sensor voltage	⊕	PE (internally jumpered, but not connected to PE screw)
–		L5+	Voltage supply, internal logic and sensor voltage 24 V	M5	Ground connection, internal logic and sensor voltage	⊕	

¹ TB2-4/DC only; in the TB4M/DC tier 4 is available for additional ground connections (see Section 7.2.7)

Important Note on Wiring

The following notes are important as regards the wiring of the ET 200B-32DI and ET 200B-32DI 0.2 ms:

- The terminals for PE on the 4-tier terminal block are not connected to the PE connection of terminal block TB2-4/DC.
- L5+ and terminals 33 ... 64 are interconnected, as are M5 and terminals 65 ... 96.
- The two L5+ terminals are also internally interconnected.

Fuse

The 24 V sensor supply is protected by fuse F1 (2.5 A) in the terminal blocks. Nevertheless, make sure that the current does not exceed the specifications in the technical data for the electronics block.

Technical Data

The technical data of electronics blocks ET 200B-32DI and ET 200B-32DI 0.2 ms is listed in the tables below.

Technical specifications		Inputs	
Baud rates* for 6ES7 131-0BL10-0XB0 and 6ES7 131-0BL00-0BL0	9.6/19.2/93.75/187.5/500/ 1500/3000/6000/ 12000 kbaud	Number of inputs	32
Bus protocol for 6ES7 131-0BL10-0XB0 and 6ES7 131-0BL00-0XB0	PROFIBUS-DP	Galvanic isolation to inter- nal electronic circuits	No
FREEZE capability for 6ES7 131-0BL10-0XB0 and 6ES7 131-0BL00-0XB0	Yes	Input voltage	
Galvanic isolation to SI- NEC L2-DP	Yes	• Rated value	24 V DC
Power losses	Typ. 4.8 W	• For "0" signal	- 30 V to 5 V
Weight (EB and TB)	Approx. 800 g (28 oz.)	• For "1" signal	13 V to 30 V
Dimensions (EB and TB): W x H x D)	235 x 130 x 60 mm (9.17 x 5.07 x 2.34 in.)	Input current for "1" signal	Typ. 4 mA for 24 V Min. 2 mA
Diagnostics functions		Delay of inputs for 6ES7 131-0BL00-0XB0	3 ms
Voltage monitoring	Green "RUN" LED	Delay of inputs for 6ES7 131-0BL10-0XB0	0.2 ms
Bus monitoring SI- NEC L2-DP	Red "BF" LED	Connection of 2-wire BERO	Possible
Status of inputs	Green LEDs	• Quiescent current	≤ 1.5 mA
Supply voltage for inputs, sensor supply and internal logic		Connection of mechanical switches	Possible
Supply logic (L5+)		Cable length of sensors	
• Rated value	24 V DC	• Unshielded	Max. 100 m (328 ft.)
• Permissible range	18.5 to 30.2 V	* In operation with the IM 308-B, the maximum baud rate is 1500 kbaud.	
• Value for t < 0.5 s	35 V		
Current consumption from L5+			
• Logic	Typ. 70 mA		
• Sensors	Max. 1 A		
I ² t (for inrush current)	≤ 0.05 A ² s		

7.3.3 Electronics Block ET 200B-16DO (6ES7 132-0BH01-0XB0)

Characteristics The ET 200B-16DO electronics block has the following characteristics:

- 16 outputs, non-floating
- Load voltage: 24 V DC
- Output current: $12 \times 0.5 \text{ A}$, $4 \times 2 \text{ A}$
- Suitable for solenoid valves and DC contactors.
- Possible terminal blocks: TB1/DC, TB1-4/DC, TB3/DC

Dimensional Drawing See Figure 7-18 for the precise dimensions.

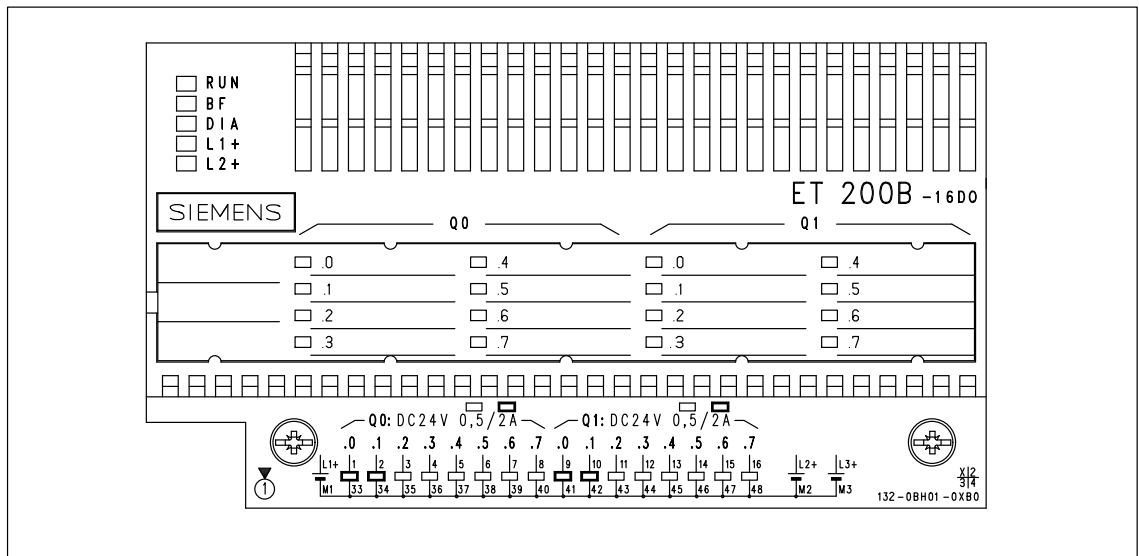

Figure 7-26 Front Elevation: ET 200B-16DO (6ES7 132-0BH01-0XB0)

Block Diagram

Simplified diagram of potential for the ET 200B-16DO and TB1/DC or TB3/DC:

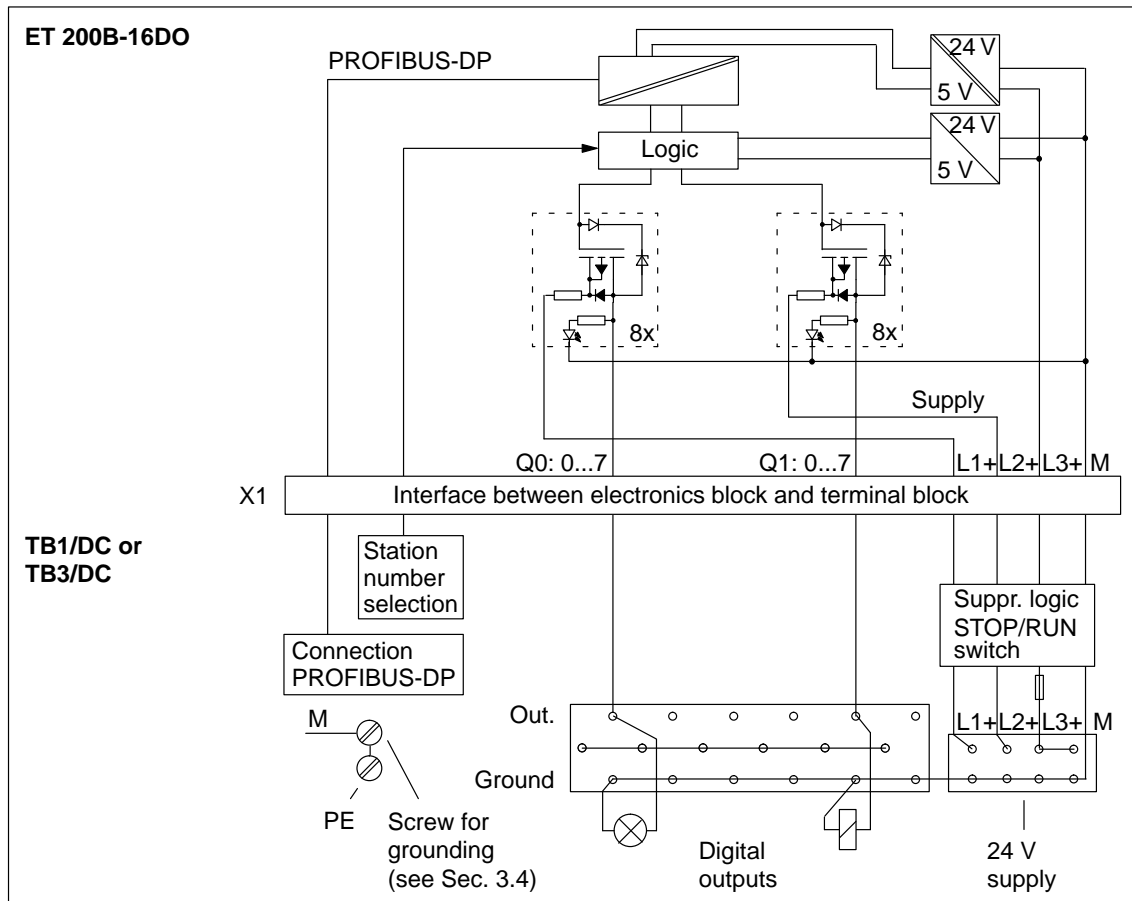

Figure 7-27 Block Diagram: ET 200B-16DO (6ES7 132-0BH01-0XB0) and TB1/DC or TB3/DC

Block Diagram Simplified diagram of the potential for the ET 200B-16DO and TB1-4/DC:

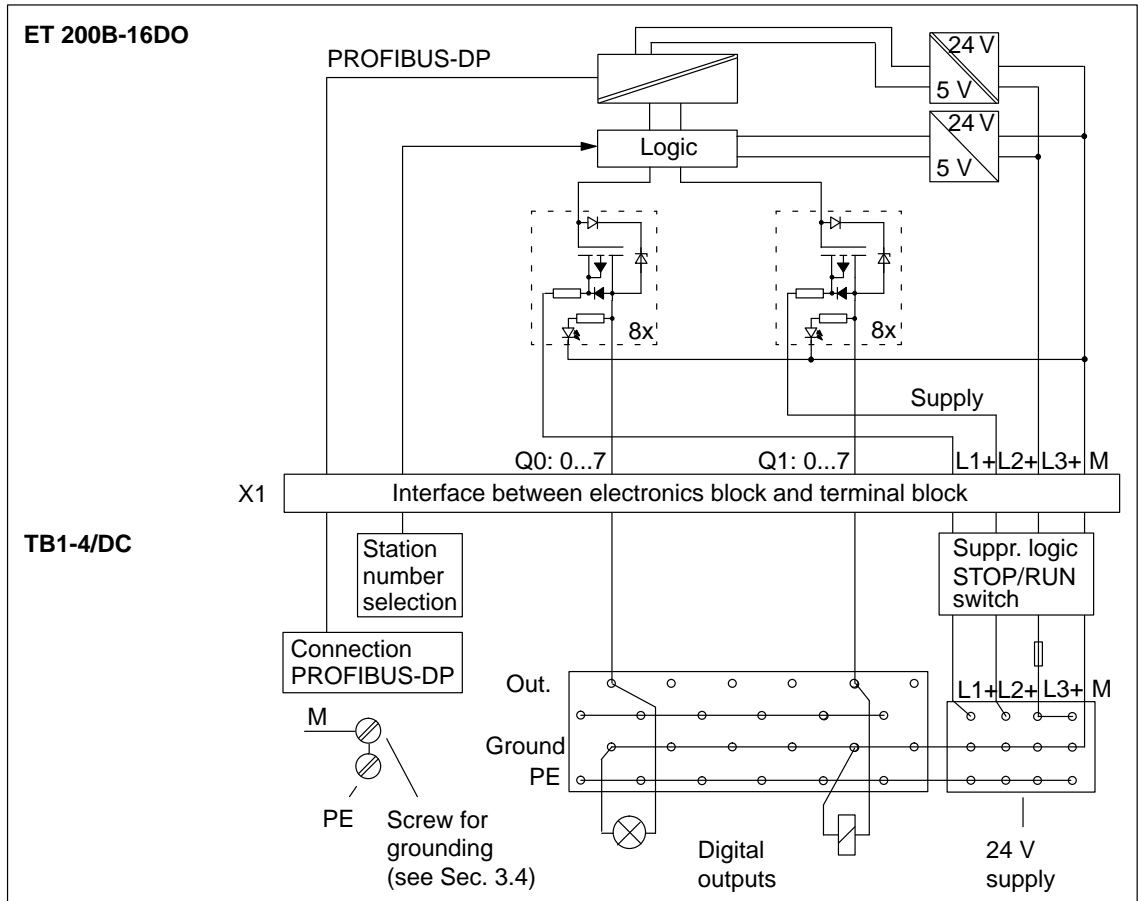

Figure 7-28 Block Diagram: ET 200B-16DO (6ES7 132-0BH01-0XB0) and TB1-4/DC

Pin Assignment

The table below shows the pin assignment of the terminal blocks for ET 200B-16DO. For the sake of clarity, the table also shows the terminal numbering of the terminal blocks, taking the TB1-4/DC by way of example.

Table 7-5 Pin Assignment of Terminal Blocks TB1/DC, TB1-4/DC and TB3/DC for ET 200B-16DO (6ES7 132-0BH01-0XB0)

Terminal tier 1		Terminal tier 2		Terminal tier 3		Terminal tier 4 ¹	
1	Q0: Output .0*	17	not used (internally jumpered)	33	Ground (internally jumpered, connected to M1, M2, M3)	⊕	PE (internally jumpered, but not connected to PE screw)
2	Q0: Output .1*	18		34		⊕	
3	Q0: Output .2	19		35		⊕	
4	Q0: Output .3	20		36		⊕	
5	Q0: Output .4	21		37		⊕	
6	Q0: Output .5	22		38		⊕	
7	Q0: Output .6	23		39		⊕	
8	Q0: Output .7	24		40		⊕	
9	Q1: Output .0*	25		41		⊕	
10	Q1: Output .1*	26		42		⊕	
11	Q1: Output .2	27		43		⊕	
12	Q1: Output .3	28		44		⊕	
13	Q1: Output .4	29		45		⊕	
14	Q1: Output .5	30		46		⊕	
15	Q1: Output .6	31		47		⊕	
16	Q1: Output .7	32		48		⊕	
-		L1+	Voltage supply L1+ for channel group Q0: .0 to .7	M1	Ground supply M1 for channel group Q0: .0 to .7	⊕	PE (internally jumpered, but not connected to PE screw)
-		L2+	Voltage supply L2+ for channel group Q1: .0 to .7	M2	Ground supply M2 for channel group Q1: .0 to .7	⊕	

* The maximum load for these outputs is 2A, the maximum load for all other outputs is 0.5 A.

Table 7-5 Pin Assignment of Terminal Blocks TB1/DC, TB1-4/DC and TB3/DC for ET 200B-16DO (6ES7 132-0BH01-0XB0), continued

Terminal tier 1		Terminal tier 2		Terminal tier 3		Terminal tier 4 ¹	
–		L3+	Voltage supply, internal logic	M3	Ground connection, internal logic	⊕	PE (internally jumped but not connected to PE screw)
–		L3+	Voltage supply, internal logic	M3	Ground connection, internal logic	⊕	

1 TB1-4/DC only

Important Note on Wiring

The following notes are important as regards the wiring of the ET 200B-16DO:

- The terminals for PE on the 4-tier terminal block are not connected to the PE connection of terminal block TB1-4/DC.
- L1+, L2+ and L3+ are **not** interconnected.
- M1, M2, M3 and terminals 33 ... 48 are internally interconnected.
- The two L3+ terminals are internally interconnected.

Technical Data

The technical data of electronics block ET 200B-16DO is listed in the tables below.

Technical specifications		Outputs	
Baud rates*	9.6/19.2/93.75/187.5/500/ 1500/3000/6000/ 12000 kbaud	Number of outputs	16
Bus protocol	PROFIBUS-DP	Galvanic isolation	No
SYNC capability	Yes	• In groups of	8
Galvanic isolation to SI- NEC L2-DP bus	Yes	Output voltage	
Power losses	Max. 5 W	• For "0" signal	Max. 2 V (idle)
Weight (EB and TB)	Approx. 600 g (21 oz.)	• For "1" signal	Min. (supply voltage – 3 V)
Dimensions (EB and TB: W x H x D)	160 x 130 x 60 mm (6.24 x 5.07 x 2.34 in.)	Output voltage	
Diagnostics functions		• For "0" signal	Max. 1 mA
Voltage monitoring	Green "RUN" LED	• For "1" signal	Max. 2 A (2 outputs per group; .0 and .1) Max. 0.5 A (6 outputs per group; .2 to .7)
Bus monitoring SI- NEC L2-DP	Red "BF" LED	Delay of outputs	Max. 1 ms
Group diagnostics for short-circuit, load voltage failure	Red "DIA" LED	• At max. lamp load	Max. 80 ms
Load voltage monitoring, by group	Green "L1+", "L2+" LEDs	Switching frequency	
Status of outputs	Green LEDs	• Resistive load	Max. 100 Hz
Supply voltage for outputs, load voltage supply and internal logic		• Inductive load	Max. 0.5 Hz
Supply voltages (L1+,L2+,L3+)		• Lamp load	Max. 8 Hz
• Rated value	24 V DC	Load current per group	
• Permissible range	18.5 to 30.2 V	• Total current	Max. 4 A
• Value for $t < 0.5$ s	35 V	• In case of short-circuit	Max. 6.5 A
Current consumption from L3+		Lamp load	
• Logic	80 mA	• At $I = 0.5$ A	Max. 5 W
I^2t (for inrush current)	≤ 0.05 A ² s	• At $I = 2$ A	Max. 10 W
Short-circuit protection in case of polarity reversal (L1+ and L2+) of load voltage	No	Setting a digital input	Possible
		Limitation of voltage in- duced on current interrup- tion	Typ. (L1+, L2+) –55 V
		Cable length	Max. 100 m (328 ft.)

* In operation with the IM 308-B, the maximum baud rate is 1500 kbaud.

7.3.4 Electronics Block ET 200B-16DO/2A (6ES7 132-0BH11-0XB0)

Characteristics The ET 200B-16DO/2A electronics block has the following characteristics:

- 16 outputs, floating in groups of 4
- Load voltage: 24 V DC
- Output current: 2 A
- Possible terminal blocks: TB2/DC, TB2-4/DC, TB4/DC, TB4M/DC

Dimensional Drawing See Figure 7-22 for the precise dimensions.

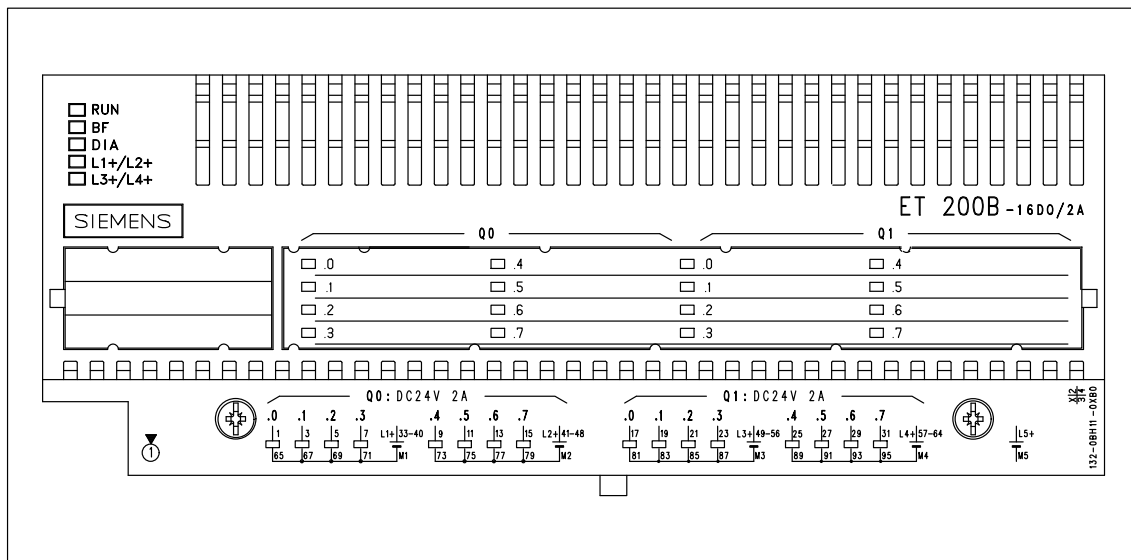

Figure 7-29 Front Elevation: ET 200B-16DO/2A (6ES7 132-0BH11-0XB0)

Block Diagram

Simplified diagram of potential for the ET 200B-16DO/2A and TB2/DC or TB4/DC:

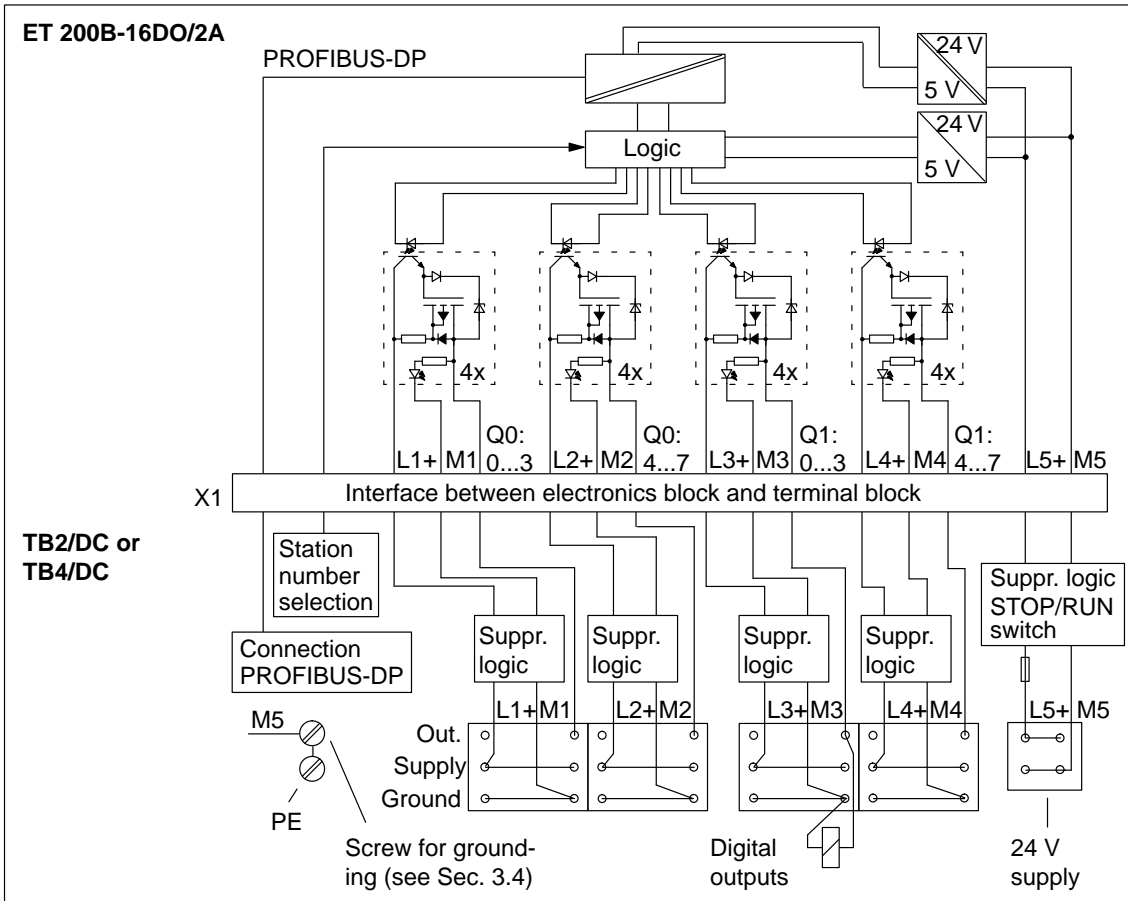

Figure 7-30 Block Diagram: ET 200B-16DO/2A (6ES7 132-0BH11-0XB0) and TB2/DC or TB4/DC

Block Diagram

Simplified diagram of the potential for the ET 200B-16DO/2A and TB2/DC or TB4/DC:

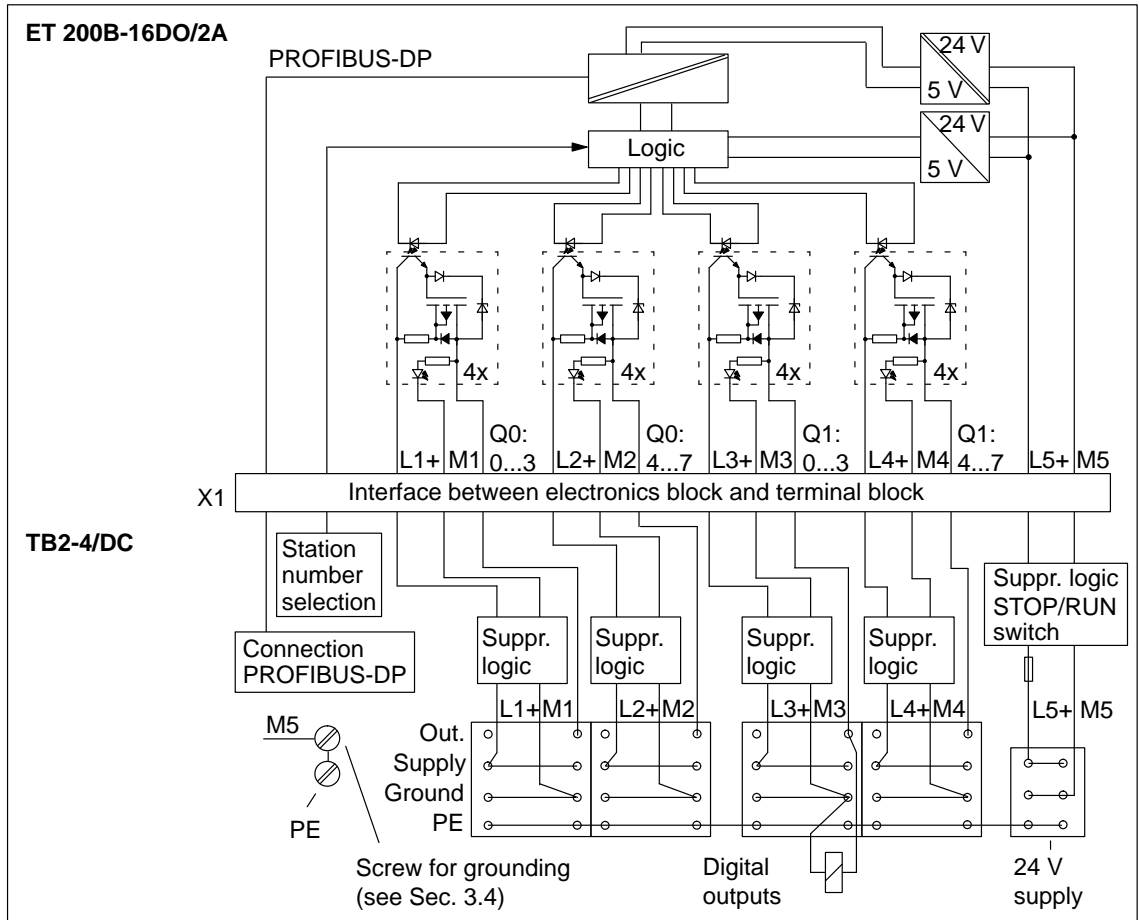

Figure 7-31 Block Diagram: ET 200B-16DO/2A (6ES7 132-0BH11-0XB0) and TB2-4/DC

Pin Assignment

The table below shows the pin assignment of the terminal blocks for ET 200B-16DO/2A. For the sake of clarity, the table also shows the terminal numbering of the terminal blocks, taking the TB2-4/DC by way of example.

Table 7-6 Pin Assignment of Terminal Blocks TB2/DC; TB2-4/DC, TB4/DC and TB4M/DC for ET 200B-16DO/2A (6ES7 132-0BH11-0XB0)

Terminal numbering TB2-4/DC																																																																																																																																																				
1	2	3	4	5	6	7	8	9	10	11	12	13	14	15	16	17	18	19	20	21	22	23	24	25	26	27	28	29	30	31	32																																																																																																																					
33	34	35	36	37	38	39	40	41	42	43	44	45	46	47	48	49	50	51	52	53	54	55	56	57	58	59	60	61	62	63	64	L5+	L5+																																																																																																																			
65	66	67	68	69	70	71	72	73	74	75	76	77	78	79	80	81	82	83	84	85	86	87	88	89	90	91	92	93	94	95	96	M5	M5																																																																																																																			
<table border="1"> <thead> <tr> <th>Terminal tier 1</th> <th>Terminal tier 2</th> <th>Terminal tier 3</th> <th>Terminal tier 4¹</th> </tr> </thead> <tbody> <tr> <td>1</td><td>Q0: Output .0</td><td>33</td><td rowspan="8">Voltage supply L1+ for channel group Q0: .0 to .3 (internally jumpered)</td><td>65</td><td rowspan="8">Ground M1 for channel group Q0: .0 to .3 (internally jumpered)</td><td>⊕</td><td rowspan="8">PE (internally jumpered, but not connected to PE screw)</td> </tr> <tr> <td>2</td><td>not used</td><td>34</td><td>66</td><td>⊕</td> </tr> <tr> <td>3</td><td>Q0: Output .1</td><td>35</td><td>67</td><td>⊕</td> </tr> <tr> <td>4</td><td>not used</td><td>36</td><td>68</td><td>⊕</td> </tr> <tr> <td>5</td><td>Q0: Output .2</td><td>37</td><td>69</td><td>⊕</td> </tr> <tr> <td>6</td><td>not used</td><td>38</td><td>70</td><td>⊕</td> </tr> <tr> <td>7</td><td>Q0: Output .3</td><td>39</td><td>71</td><td>⊕</td> </tr> <tr> <td>8</td><td>not used</td><td>40</td><td>72</td><td>⊕</td> </tr> <tr> <td>9</td><td>Q0: Output .4</td><td>41</td><td rowspan="8">Voltage supply L2+ for channel group Q0: .4 to .7 (internally jumpered)</td><td>73</td><td rowspan="8">Ground M2 for channel group Q0: .4 to .7 (internally jumpered)</td><td>⊕</td><td rowspan="8"></td> </tr> <tr> <td>10</td><td>not used</td><td>42</td><td>74</td><td>⊕</td> </tr> <tr> <td>11</td><td>Q0: Output .5</td><td>43</td><td>75</td><td>⊕</td> </tr> <tr> <td>12</td><td>not used</td><td>44</td><td>76</td><td>⊕</td> </tr> <tr> <td>13</td><td>Q0: Output .6</td><td>45</td><td>77</td><td>⊕</td> </tr> <tr> <td>14</td><td>not used</td><td>46</td><td>78</td><td>⊕</td> </tr> <tr> <td>15</td><td>Q0: Output .7</td><td>47</td><td>79</td><td>⊕</td> </tr> <tr> <td>16</td><td>not used</td><td>48</td><td>80</td><td>⊕</td> </tr> <tr> <td>17</td><td>Q1: Output .0</td><td>49</td><td rowspan="8">Voltage supply L3+ for channel group Q1: .0 to .3 (internally jumpered)</td><td>81</td><td rowspan="8">Ground M3 for channel group Q1: .0 to .3 (internally jumpered)</td><td>⊕</td><td rowspan="8"></td> </tr> <tr> <td>18</td><td>not used</td><td>50</td><td>82</td><td>⊕</td> </tr> <tr> <td>19</td><td>Q1: Output .1</td><td>51</td><td>83</td><td>⊕</td> </tr> <tr> <td>20</td><td>not used</td><td>52</td><td>84</td><td>⊕</td> </tr> <tr> <td>21</td><td>Q1: Output .2</td><td>53</td><td>85</td><td>⊕</td> </tr> <tr> <td>22</td><td>not used</td><td>54</td><td>86</td><td>⊕</td> </tr> <tr> <td>23</td><td>Q1: Output .3</td><td>55</td><td>87</td><td>⊕</td> </tr> <tr> <td>24</td><td>not used</td><td>56</td><td>88</td><td>⊕</td> </tr> </tbody> </table>																Terminal tier 1	Terminal tier 2	Terminal tier 3	Terminal tier 4 ¹	1	Q0: Output .0	33	Voltage supply L1+ for channel group Q0: .0 to .3 (internally jumpered)	65	Ground M1 for channel group Q0: .0 to .3 (internally jumpered)	⊕	PE (internally jumpered, but not connected to PE screw)	2	not used	34	66	⊕	3	Q0: Output .1	35	67	⊕	4	not used	36	68	⊕	5	Q0: Output .2	37	69	⊕	6	not used	38	70	⊕	7	Q0: Output .3	39	71	⊕	8	not used	40	72	⊕	9	Q0: Output .4	41	Voltage supply L2+ for channel group Q0: .4 to .7 (internally jumpered)	73	Ground M2 for channel group Q0: .4 to .7 (internally jumpered)	⊕		10	not used	42	74	⊕	11	Q0: Output .5	43	75	⊕	12	not used	44	76	⊕	13	Q0: Output .6	45	77	⊕	14	not used	46	78	⊕	15	Q0: Output .7	47	79	⊕	16	not used	48	80	⊕	17	Q1: Output .0	49	Voltage supply L3+ for channel group Q1: .0 to .3 (internally jumpered)	81	Ground M3 for channel group Q1: .0 to .3 (internally jumpered)	⊕		18	not used	50	82	⊕	19	Q1: Output .1	51	83	⊕	20	not used	52	84	⊕	21	Q1: Output .2	53	85	⊕	22	not used	54	86	⊕	23	Q1: Output .3	55	87	⊕	24	not used	56	88	⊕
Terminal tier 1	Terminal tier 2	Terminal tier 3	Terminal tier 4 ¹																																																																																																																																																	
1	Q0: Output .0	33	Voltage supply L1+ for channel group Q0: .0 to .3 (internally jumpered)	65	Ground M1 for channel group Q0: .0 to .3 (internally jumpered)	⊕	PE (internally jumpered, but not connected to PE screw)																																																																																																																																													
2	not used	34		66		⊕																																																																																																																																														
3	Q0: Output .1	35		67		⊕																																																																																																																																														
4	not used	36		68		⊕																																																																																																																																														
5	Q0: Output .2	37		69		⊕																																																																																																																																														
6	not used	38		70		⊕																																																																																																																																														
7	Q0: Output .3	39		71		⊕																																																																																																																																														
8	not used	40		72		⊕																																																																																																																																														
9	Q0: Output .4	41	Voltage supply L2+ for channel group Q0: .4 to .7 (internally jumpered)	73	Ground M2 for channel group Q0: .4 to .7 (internally jumpered)	⊕																																																																																																																																														
10	not used	42		74		⊕																																																																																																																																														
11	Q0: Output .5	43		75		⊕																																																																																																																																														
12	not used	44		76		⊕																																																																																																																																														
13	Q0: Output .6	45		77		⊕																																																																																																																																														
14	not used	46		78		⊕																																																																																																																																														
15	Q0: Output .7	47		79		⊕																																																																																																																																														
16	not used	48		80		⊕																																																																																																																																														
17	Q1: Output .0	49	Voltage supply L3+ for channel group Q1: .0 to .3 (internally jumpered)	81	Ground M3 for channel group Q1: .0 to .3 (internally jumpered)	⊕																																																																																																																																														
18	not used	50		82		⊕																																																																																																																																														
19	Q1: Output .1	51		83		⊕																																																																																																																																														
20	not used	52		84		⊕																																																																																																																																														
21	Q1: Output .2	53		85		⊕																																																																																																																																														
22	not used	54		86		⊕																																																																																																																																														
23	Q1: Output .3	55		87		⊕																																																																																																																																														
24	not used	56		88		⊕																																																																																																																																														

Table 7-6 Pin Assignment of Terminal Blocks TB2/DC; TB2-4/DC, TB4/DC and TB4M/DC for ET 200B-16DO/2A (6ES7 132-0BH11-0XB0), continued

Terminal tier 1		Terminal tier 2		Terminal tier 3		Terminal tier 4 ¹	
25	Q1: Output .4	57	Voltage supply L4+ for channel group Q1: .4 to .7 (internally jumpered)	89	Ground M4 for channel group Q1: .4 to .7 (internally jumpered)	⊕	PE (internally jumpered, but not connected to PE screw)
26	not used	58		90		⊕	
27	Q1: Output .5	59		91		⊕	
28	not used	60		92		⊕	
29	Q1: Output .6	61		93		⊕	
30	not used	62		94		⊕	
31	Q1: Output .7	63		95		⊕	
32	not used	64		96		⊕	
–		L5+	Voltage supply, internal logic	M5	Ground connection, internal logic	⊕	PE (internally jumpered, but not connected to PE screw)
–		L5+	Voltage supply, internal logic	M5	Ground connection, internal logic	⊕	

¹ TB2-4/DC only; in the TB4M/DC tier 4 is available for additional ground connections (see Section 7.2.7)

Important Note on Wiring

The following notes are important as regards the wiring of the ET 200B-16DO/2A:

- The terminals for PE on the 4-tier terminal block are not connected to the PE connection of terminal block TB2-4/DC.
- L1+ ... L5+ and M1 ... M5 are **not** internally interconnected.
- The two L5+ terminals are internally interconnected.

Technical Data

The technical data of electronics block ET 200B-16DO/2A is listed in the tables below.

Technical specifications		Outputs	
Baud rates*	9.6/19.2/93.75/187.5/500/ 1500/3000/6000/ 12000 kbaud	Number of outputs	16
Bus protocol	PROFIBUS-DP	Galvanic isolation	Yes
SYNC capability	Yes	• In groups of	4
Galvanic isolation to SI- NEC L2-DP bus	Yes	Output voltage	
Power losses	Max. 7 W	• For "0" signal	Max. 2 V (idle)
Weight (EB and TB)	Approx. 900 g (31.5 oz.)	• For "1" signal	Min. (supply voltage – 3 V)
Dimensions (EB and TB: W x H x D)	235 x 130 x 60 mm (9.17 x 5.07 x 2.34 in.)	Output	
Diagnostics functions		• For "0" signal	Max. 1 mA
Voltage monitoring	Green "RUN" LED	• For "1" signal	Max. 2 A
Bus monitoring SINEC L2-DP	Red "BF" LED	Delay of outputs	Max. 1 ms
Group diagnostics for short-circuit, load voltage failure	Red "DIA" LED	• At max. lamp load	Max. 80 ms
Load voltage monitoring, by channel group (Q0, Q1)	Green LEDs "L1+/"L2+" (Q0: .0 to 7) "L3+/"L4+" (Q1: .0 to 7)	Switching frequency	
Status of outputs	Green LEDs	• Resistive load	Max. 100 Hz
Supply voltage for outputs, load voltage supply and internal logic		• Inductive load	Max. 0.5 Hz
Supply voltage (L1+,L2+,L3+,L4+,L5+)		• Lamp load	Max. 8 Hz
• Rated value	24 V DC	Load current per group	
• Permissible range	18.5 to 30.2 V	• Total current	Max. 4 A
• Value at t < 0.5 s	35 V	• In case of short-circuit	Max. 6.5 A
Current consumption from L5+		Lamp load	Max. 10 W
• Logic	100 mA	Setting a digital input	Possible
I ² t (for inrush current)	≤ 0.05 A ² s	Limit of inductive cutoff voltage	Typ. (L1+ ... L4+) – 50 V
Short-circuit protection in case of polarity reversal (L1+,L2+,L3+,L4+) of load voltage	No	Cable length	Max. 100 m (328 ft.)

* In operation with the IM 308-B, the maximum baud rate is 1500 kbaud.

7.3.5 Electronics Block ET 200B-32DO (6ES7 132-0BL01-0XB0)

Characteristics

The ET 200B-32DO electronics block has the following characteristics:

- 32 outputs, floating in groups of 8
- Load voltage: 24 V DC
- Output voltage: 0.5 A
- Suitable for solenoid valves and DC contactors
- Possible terminal blocks: TB2/DC, TB2-4/DC, TB4/DC, TB4M/DC

Dimensional Drawing

See Figure 7-22 for the precise dimensions.

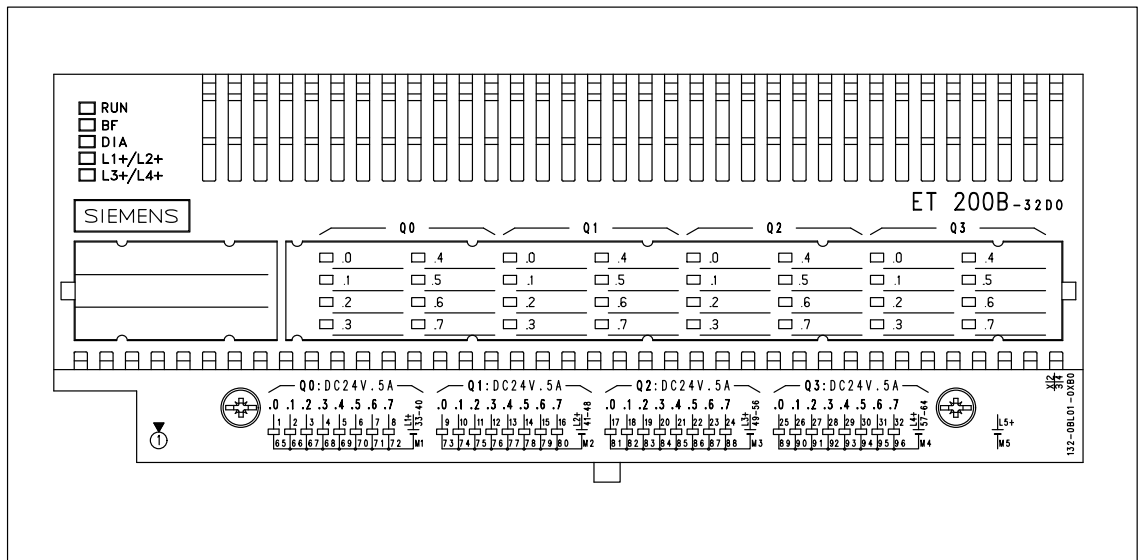

Figure 7-32 Front Elevation: ET 200B-32DO (6ES7 132-0BL01-0XB0)

Block Diagram

Simplified diagram of potential for the ET 200B-32DO and TB2/DC or TB4/DC:

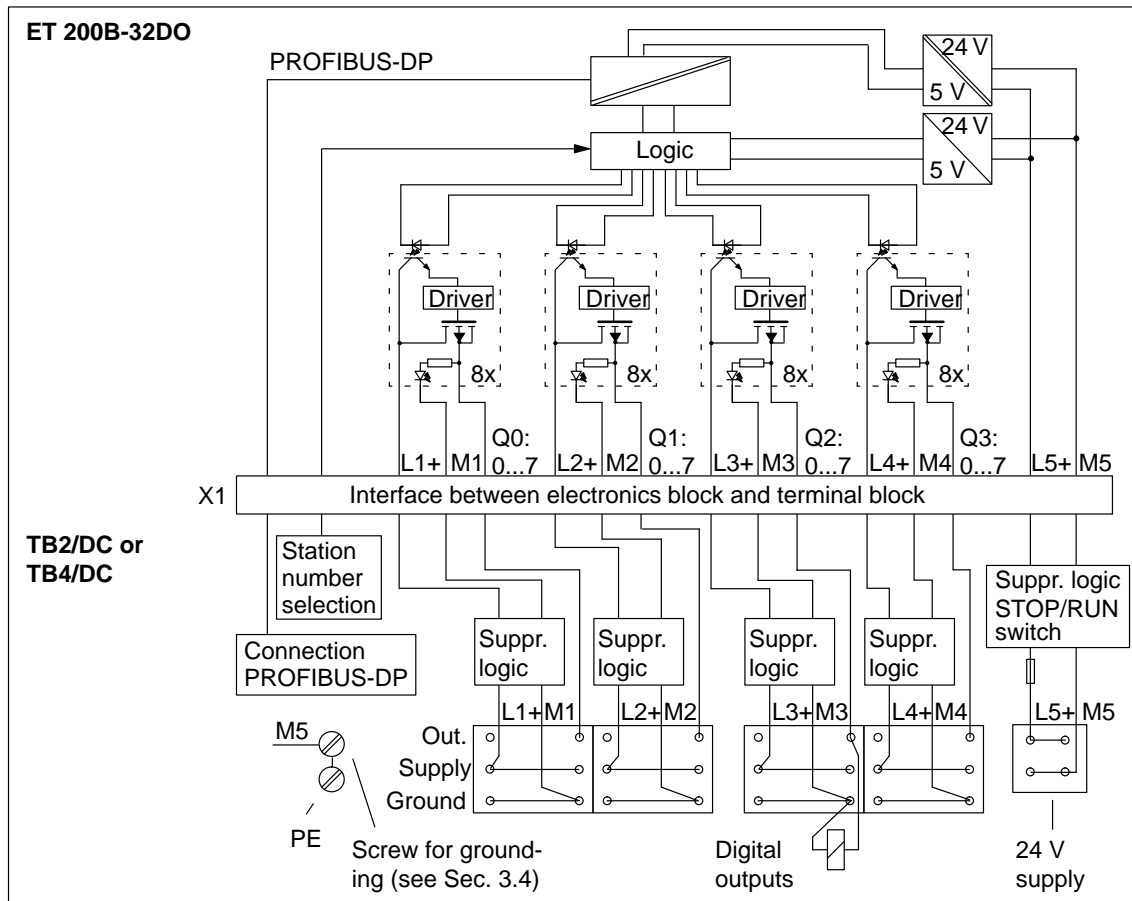

Figure 7-33 Block Diagram: ET 200B-32DO (6ES7 132-0BL01-0XB0) and TB2/DC or TB4/DC

Block Diagram Simplified diagram of the potential for the ET 200B-32DO and TB2-4/DC:

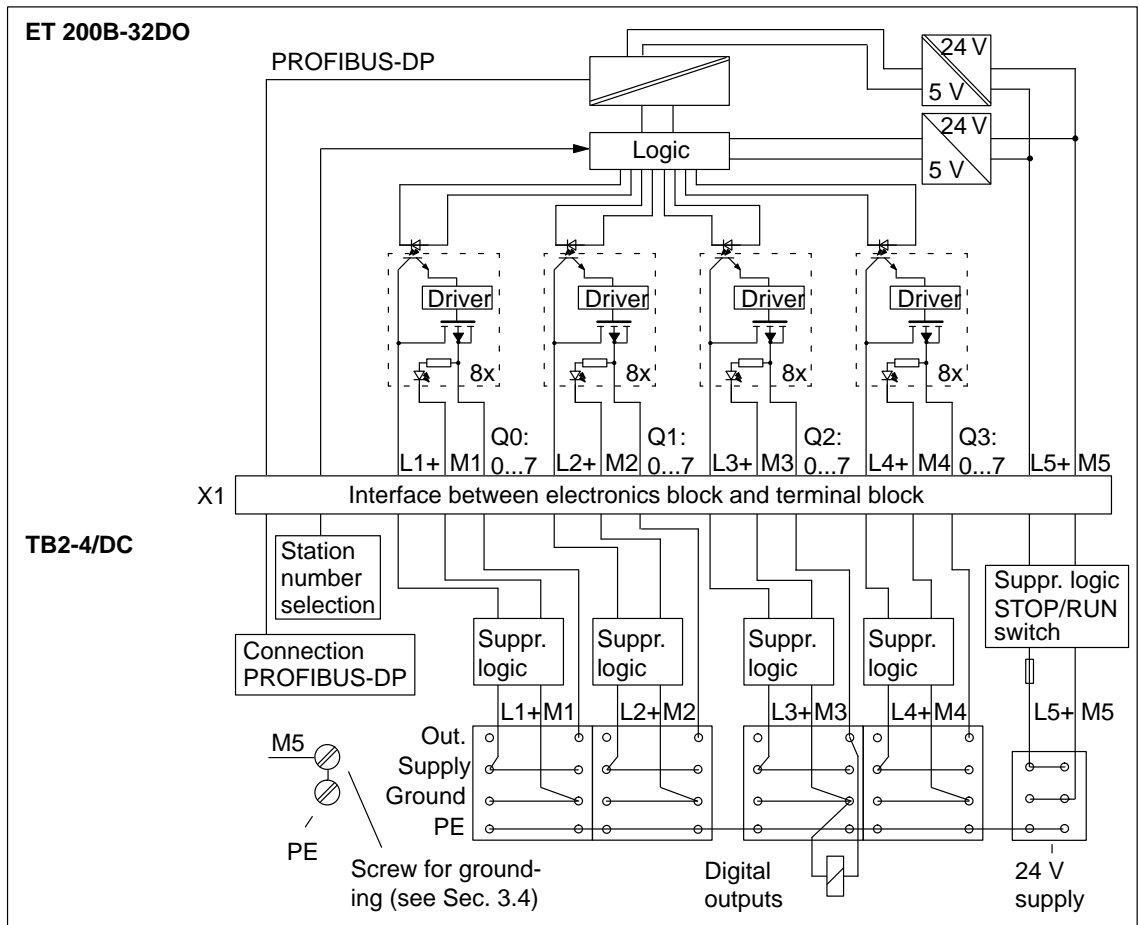

Figure 7-34 Block Diagram: ET 200B-32DO (6ES7 132-0BL01-0XB0) and TB2-4/DC

Pin Assignment

The table below shows the pin assignment of the terminal blocks for ET 200B-32DO. For the sake of clarity, the table also shows the terminal numbering of the terminal blocks, taking the TB2-4/DC by way of example.

Table 7-7 Pin Assignment of Terminal Blocks TB2/DC, TB2-4/DC, TB4/DC and TB4M/DC for ET 200B-32DO (6ES7 132-0BL01-0XB0)

Terminal numbering TB2-4/DC																																																																																																																																																				
1	2	3	4	5	6	7	8	9	10	11	12	13	14	15	16	17	18	19	20	21	22	23	24	25	26	27	28	29	30	31	32																																																																																																																					
33	34	35	36	37	38	39	40	41	42	43	44	45	46	47	48	49	50	51	52	53	54	55	56	57	58	59	60	61	62	63	64	L5+	L5+																																																																																																																			
65	66	67	68	69	70	71	72	73	74	75	76	77	78	79	80	81	82	83	84	85	86	87	88	89	90	91	92	93	94	95	96	M5	M5																																																																																																																			
<table border="1"> <thead> <tr> <th>Terminal tier 1</th> <th>Terminal tier 2</th> <th>Terminal tier 3</th> <th>Terminal tier 4¹</th> </tr> </thead> <tbody> <tr> <td>1</td><td>Q0: Output .0</td><td>33</td><td rowspan="8">Voltage supply L1+ for channel group Q0: .0 to .7 (internally jumpered)</td> <td>65</td><td rowspan="8">Ground M1 for channel group Q0: .0 to .7 (internally jumpered)</td> <td>⊕</td><td rowspan="8">PE (internally jumpered, but not connected to PE screw)</td> </tr> <tr> <td>2</td><td>Q0: Output .1</td><td>34</td> <td>66</td> <td>⊕</td> </tr> <tr> <td>3</td><td>Q0: Output .2</td><td>35</td> <td>67</td> <td>⊕</td> </tr> <tr> <td>4</td><td>Q0: Output .3</td><td>36</td> <td>68</td> <td>⊕</td> </tr> <tr> <td>5</td><td>Q0: Output .4</td><td>37</td> <td>69</td> <td>⊕</td> </tr> <tr> <td>6</td><td>Q0: Output .5</td><td>38</td> <td>70</td> <td>⊕</td> </tr> <tr> <td>7</td><td>Q0: Output .6</td><td>39</td> <td>71</td> <td>⊕</td> </tr> <tr> <td>8</td><td>Q0: Output .7</td><td>40</td> <td>72</td> <td>⊕</td> </tr> <tr> <td>9</td><td>Q1: Output .0</td><td>41</td><td rowspan="8">Voltage supply L2+ for channel group Q1: .4 to .7 (internally jumpered)</td> <td>73</td><td rowspan="8">Ground M2 for channel group Q01: .0 to .7 (internally jumpered)</td> <td>⊕</td> <td rowspan="8"></td> </tr> <tr> <td>10</td><td>Q1: Output .1</td><td>42</td> <td>74</td> <td>⊕</td> </tr> <tr> <td>11</td><td>Q1: Output .2</td><td>43</td> <td>75</td> <td>⊕</td> </tr> <tr> <td>12</td><td>Q1: Output .3</td><td>44</td> <td>76</td> <td>⊕</td> </tr> <tr> <td>13</td><td>Q1: Output .4</td><td>45</td> <td>77</td> <td>⊕</td> </tr> <tr> <td>14</td><td>Q1: Output .5</td><td>46</td> <td>78</td> <td>⊕</td> </tr> <tr> <td>15</td><td>Q1: Output .6</td><td>47</td> <td>79</td> <td>⊕</td> </tr> <tr> <td>16</td><td>Q1: Output .7</td><td>48</td> <td>80</td> <td>⊕</td> </tr> <tr> <td>17</td><td>Q2: Output .0</td><td>49</td><td rowspan="8">Voltage supply L3+ for channel group Q2: .0 to .7 (internally jumpered)</td> <td>81</td><td rowspan="8">Ground M3 for channel group Q2: .0 to .7 (internally jumpered)</td> <td>⊕</td> <td rowspan="8"></td> </tr> <tr> <td>18</td><td>Q2: Output .1</td><td>50</td> <td>82</td> <td>⊕</td> </tr> <tr> <td>19</td><td>Q2: Output .2</td><td>51</td> <td>83</td> <td>⊕</td> </tr> <tr> <td>20</td><td>Q2: Output .3</td><td>52</td> <td>84</td> <td>⊕</td> </tr> <tr> <td>21</td><td>Q2: Output .4</td><td>53</td> <td>85</td> <td>⊕</td> </tr> <tr> <td>22</td><td>Q2: Output .5</td><td>54</td> <td>86</td> <td>⊕</td> </tr> <tr> <td>23</td><td>Q2: Output .6</td><td>55</td> <td>87</td> <td>⊕</td> </tr> <tr> <td>24</td><td>Q2: Output .7</td><td>56</td> <td>88</td> <td>⊕</td> </tr> </tbody> </table>																Terminal tier 1	Terminal tier 2	Terminal tier 3	Terminal tier 4 ¹	1	Q0: Output .0	33	Voltage supply L1+ for channel group Q0: .0 to .7 (internally jumpered)	65	Ground M1 for channel group Q0: .0 to .7 (internally jumpered)	⊕	PE (internally jumpered, but not connected to PE screw)	2	Q0: Output .1	34	66	⊕	3	Q0: Output .2	35	67	⊕	4	Q0: Output .3	36	68	⊕	5	Q0: Output .4	37	69	⊕	6	Q0: Output .5	38	70	⊕	7	Q0: Output .6	39	71	⊕	8	Q0: Output .7	40	72	⊕	9	Q1: Output .0	41	Voltage supply L2+ for channel group Q1: .4 to .7 (internally jumpered)	73	Ground M2 for channel group Q01: .0 to .7 (internally jumpered)	⊕		10	Q1: Output .1	42	74	⊕	11	Q1: Output .2	43	75	⊕	12	Q1: Output .3	44	76	⊕	13	Q1: Output .4	45	77	⊕	14	Q1: Output .5	46	78	⊕	15	Q1: Output .6	47	79	⊕	16	Q1: Output .7	48	80	⊕	17	Q2: Output .0	49	Voltage supply L3+ for channel group Q2: .0 to .7 (internally jumpered)	81	Ground M3 for channel group Q2: .0 to .7 (internally jumpered)	⊕		18	Q2: Output .1	50	82	⊕	19	Q2: Output .2	51	83	⊕	20	Q2: Output .3	52	84	⊕	21	Q2: Output .4	53	85	⊕	22	Q2: Output .5	54	86	⊕	23	Q2: Output .6	55	87	⊕	24	Q2: Output .7	56	88	⊕
Terminal tier 1	Terminal tier 2	Terminal tier 3	Terminal tier 4 ¹																																																																																																																																																	
1	Q0: Output .0	33	Voltage supply L1+ for channel group Q0: .0 to .7 (internally jumpered)	65	Ground M1 for channel group Q0: .0 to .7 (internally jumpered)	⊕	PE (internally jumpered, but not connected to PE screw)																																																																																																																																													
2	Q0: Output .1	34		66		⊕																																																																																																																																														
3	Q0: Output .2	35		67		⊕																																																																																																																																														
4	Q0: Output .3	36		68		⊕																																																																																																																																														
5	Q0: Output .4	37		69		⊕																																																																																																																																														
6	Q0: Output .5	38		70		⊕																																																																																																																																														
7	Q0: Output .6	39		71		⊕																																																																																																																																														
8	Q0: Output .7	40		72		⊕																																																																																																																																														
9	Q1: Output .0	41	Voltage supply L2+ for channel group Q1: .4 to .7 (internally jumpered)	73	Ground M2 for channel group Q01: .0 to .7 (internally jumpered)	⊕																																																																																																																																														
10	Q1: Output .1	42		74		⊕																																																																																																																																														
11	Q1: Output .2	43		75		⊕																																																																																																																																														
12	Q1: Output .3	44		76		⊕																																																																																																																																														
13	Q1: Output .4	45		77		⊕																																																																																																																																														
14	Q1: Output .5	46		78		⊕																																																																																																																																														
15	Q1: Output .6	47		79		⊕																																																																																																																																														
16	Q1: Output .7	48		80		⊕																																																																																																																																														
17	Q2: Output .0	49	Voltage supply L3+ for channel group Q2: .0 to .7 (internally jumpered)	81	Ground M3 for channel group Q2: .0 to .7 (internally jumpered)	⊕																																																																																																																																														
18	Q2: Output .1	50		82		⊕																																																																																																																																														
19	Q2: Output .2	51		83		⊕																																																																																																																																														
20	Q2: Output .3	52		84		⊕																																																																																																																																														
21	Q2: Output .4	53		85		⊕																																																																																																																																														
22	Q2: Output .5	54		86		⊕																																																																																																																																														
23	Q2: Output .6	55		87		⊕																																																																																																																																														
24	Q2: Output .7	56		88		⊕																																																																																																																																														

Table 7-7 Pin Assignment of Terminal Blocks TB2/DC, TB2-4/DC, TB4/DC and TB4M/DC for ET 200B-32DO (6ES7 132-0BL01-0XB0), continued

Terminal tier 1		Terminal tier 2		Terminal tier 3		Terminal tier 4 ¹	
25	Q3: Output .0	57	Voltage supply L4+ for channel group Q3: .0 to .7 (internally jumpered)	89	Ground M4 for channel group Q3: .0 to .7 (internally jumpered)	⊕	PE (internally jumpered, but not connected to PE screw)
26	Q3: Output .1	58		90		⊕	
27	Q3: Output .2	59		91		⊕	
28	Q3: Output .3	60		92		⊕	
29	Q3: Output .4	61		93		⊕	
30	Q3: Output .5	62		94		⊕	
31	Q3: Output .6	63		95		⊕	
32	Q3: Output .7	64		96		⊕	
–		L5+	Voltage supply, internal logic	M5	Ground connection, internal logic	⊕	PE (internally jumpered, but not connected to PE screw)
–		L5+	Voltage supply, internal logic	M5	Ground connection, internal logic	⊕	

¹ TB2-4/DC only; in the TB4M/DC tier 4 is available for additional ground connections (see Section 7.2.7)

Important Note on Wiring

The following notes are important as regards the wiring of the ET 200B-32DO:

- The terminals for PE on the 4-tier terminal block are not connected to the PE connection of terminal block TB2-4/DC.
- If all actuators are connected by two-wire cables to the TB2/DC, TB4/DC or TB2-4/DC, connect the ground of an actuator and the supply for the reference potential per group by means of a DIN 46231 cable cleat.
- L1+ ... L5+ and M1 ... M5 are **not** internally interconnected.
- The two L5+ terminals are internally interconnected.

Technical Data

The technical data of electronics block ET 200B-32DO is listed in the tables below.

Technical specifications		Outputs	
Baud rates*	9.6/19.2/93.75/187.5/500/ 1500/3000/6000/ 12000 kbaud	Number of outputs	32
Bus protocol	PROFIBUS-DP	Galvanic isolation	Yes
SYNC capability	Yes	• In groups of	8
Galvanic isolation to SI- NEC L2-DP bus	Yes	Output voltage	
Power losses	Max. 7.9 W	• For "0" signal	Max. 2 V (idle)
Weight (EB and TB)	Approx. 800 g (28 oz.)	• For "1" signal	Min. (supply voltage – 3 V)
Dimensions (EB and TB: W x H x D)	235 x 130 x 60 mm (9.17 x 5.07 x 2.34 in.)	Output current	
Diagnostics functions		• For "0" signal	Max. 1 mA
Voltage monitoring	Green "RUN" LED	• For "1" signal	Max. 0.5 A
Bus monitoring SINEC L2-DP	Red "BF" LED	Delay of outputs	
Group diagnostics for short-circuit, load voltage failure	Red "DIA" LED	• From "0" to "1"	Approx. 20 µs
Load voltage monitoring	Green "L1+/L2+", "L3+/L4+" LEDs	• From "1" to "0"	Max. 0.5 ms
Status of outputs	Green LEDs	Switching frequency	
Supply voltage for outputs, load voltage supply and internal logic		• Resistive load	Max. 1000 Hz
Supply voltage (L1+,L2+,L3+,L4+,L5+)		• Inductive load	Max. 0.5 Hz
• Rated value	24 V DC	• Lamp load	Max. 8 Hz
• Permissible range	18.5 to 30.2 V	Short-circuit protection	Yes
• Value for $t < 0.5$ s	35 V	Load current per group	
I^2t (for inrush current)	≤ 0.05 A ² s	• Total current	Max. 2 A
Current consumption from L5+		Lamp load	Max. 5 W
• Logic	Typ. 75 mA	Setting a digital input	Possible
		Limitation of voltage in- duced on current interrup- tion	Typ. (L1+ ... L4+) – 55 V
		Cable length	Max. 100 m (328 ft.)

* In operation with the IM 308-B, the maximum baud rate is 1500 kbaud.

7.3.6 Electronics block ET 200B-8RO (6ES7 132-0GF00-0XB0)

Characteristics

The ET 200B-8RO electronics block has the following characteristics:

- 8 relay outputs, floating in groups of 1
- Switching voltage: 24 to 60 V DC
- Possible terminal blocks: TB1/DC, TB1-4/DC or TB3/DC

Dimensional Drawing

See Figure 7-18 for the precise dimensions.

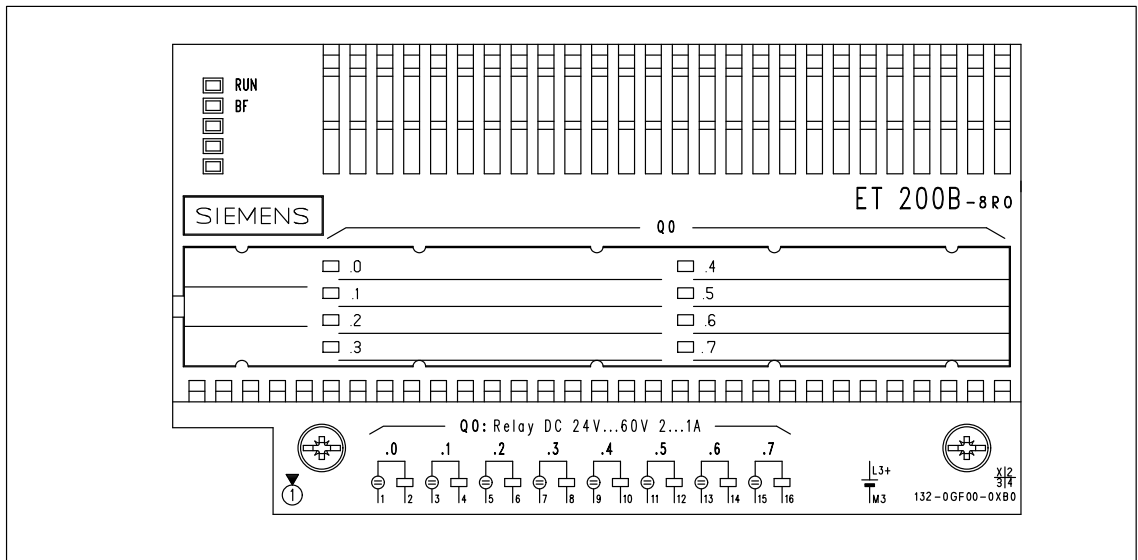

Figure 7-35 Front Elevation: ET 200B-8RO (6ES7 132-0GF00-0XB0)

Block Diagram

Simplified diagram of the potential for the ET 200B-8RO and TB1/DC or TB3/DC:

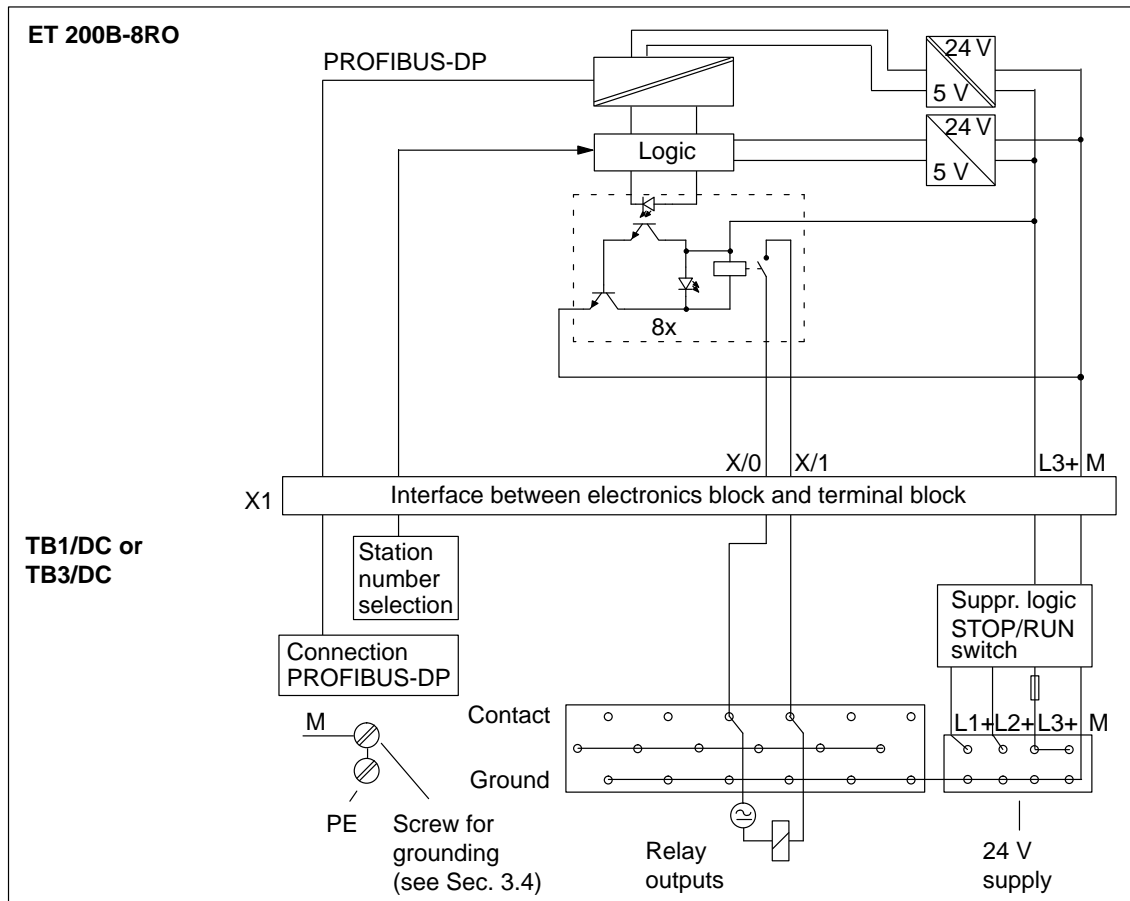

Figure 7-36 Block Diagram: ET 200B-8RO (6ES7 132-0GF00-0XB0) and TB1/DC or TB3/DC

Block Diagram Simplified diagram of the potential for the ET 200B-8RO and TB1-4/DC:

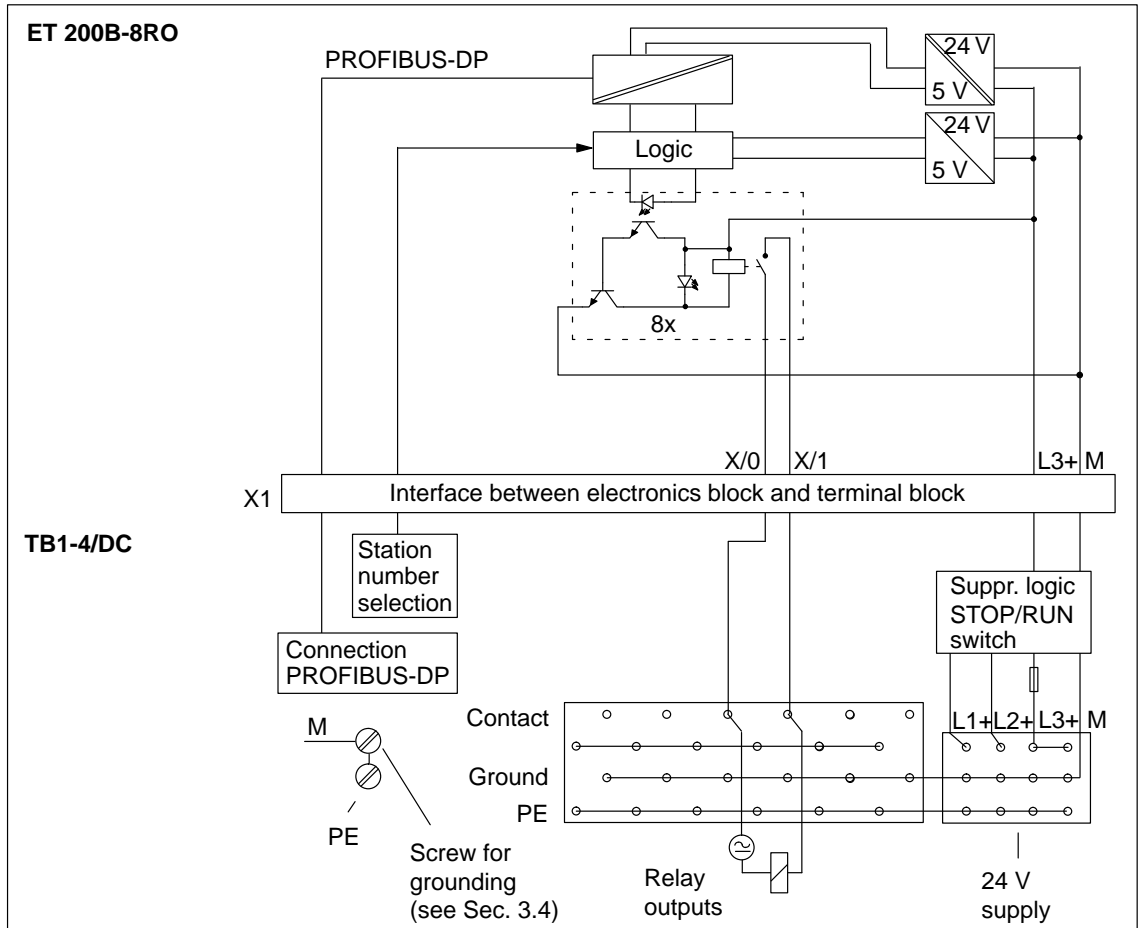
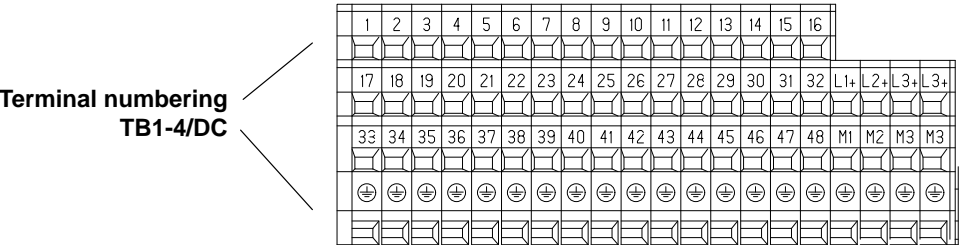

Figure 7-37 Block Diagram: ET 200B-8RO (6ES7 132-0GF00-0XB0) and TB1-4/DC

Pin Assignment

The table below shows the pin assignment of the terminal blocks for ET 200B-8RO. For the sake of clarity, the table also shows the terminal numbering of the terminal blocks, taking the TB1-4/DC by way of example.

Table 7-8 Pin Assignment of Terminal Blocks TB1/DC; TB1-4/DC and TB3/DC for ET 200B-8RO (6ES7 132-0GF00-0XB0)



Terminal tier 1		Terminal tier 2		Terminal tier 3		Terminal tier 4 ¹	
1	Q0: Connection 0/0	17	not used (internally jumpered)	33	Ground (internally jumpered, connected to M1, M2, M3)	⊕	PE (internally jumpered, but not connected to PE screw)
2	Q0: Connection 0/1	18		34		⊕	
3	Q0: Connection 1/0	19		35		⊕	
4	Q0: Connection 1/1	20		36		⊕	
5	Q0: Connection 2/0	21		37		⊕	
6	Q0: Connection 2/1	22		38		⊕	
7	Q0: Connection 3/0	23		39		⊕	
8	Q0: Connection 3/1	24		40		⊕	
9	Q0: Connection 4/0	25		41		⊕	
10	Q0: Connection 4/1	26		42		⊕	
11	Q0: Connection 5/0	27		43		⊕	
12	Q0: Connection 5/1	28		44		⊕	
13	Q0: Connection 6/0	29		45		⊕	
14	Q0: Connection 6/1	30		46		⊕	
15	Q0: Connection 7/0	31		47		⊕	
16	Q0: Connection 7/1	32		48		⊕	
-		L1+	not used	M1	not used	⊕	PE (internally jumpered, but not connected to PE screw)
-		L2+	not used	M2	not used	⊕	
-		L3+	Voltage supply, internal logic	M3	Ground connection, internal logic	⊕	
-		L3+	Voltage supply, internal logic	M3	Ground connection, internal logic	⊕	

¹ TB1-4/DC only

Important Note on Wiring

The following notes are important as regards the wiring of the ET 200B-8RO:

- The terminals for PE on the 4-tier terminal block are not connected to the PE connection of terminal block TB1-4/DC.
- M1, M2, M3 and terminals 33 ... 48 are interconnected.
- The two L3+ terminals are internally interconnected.

Technical Data

The technical data of electronics block ET 200B-8RO is listed in the tables below.

Technical specifications		Relay outputs	
Baud rates*	9.6/19.2/93.75/187.5/500/1500/3000/6000/12000 kbaud	Number of outputs	8
Bus protocol	PROFIBUS-DP	Galvanic isolation	Yes
SYNC capability	Yes	• In groups of	1
Galvanic isolation to the SINEC L2-DP bus	Yes	Short-circuit protection	No
Power losses	Typ. 2 W	Continuous current I _{th}	Max. 5 A
Weight (EB and TB)	Approx. 650 g (22.75 oz.)	Relay type	Dold OW 5699
Dimensions (EB and TB: W x H x D)	160 x 130 x 60 mm (6.24 x 5.07 x 2.34 in.)	Cycling capacity of contacts	
Diagnostics functions		• Resistive load	Max. 2 A at 24 V DC Max. 1.5 A at 48 V DC Max. 1 A at 60 V DC
Voltage monitoring	Green "RUN" LED	• Inductive load	Max. 0.5 A at 30 V DC
Bus monitoring SINEC L2-DP	Red "BF" LED	Mechanical service life	> 10 ⁸ switching operations
Status of outputs	Green LEDs	Switching rate	Max. 20/s
Supply voltage for relay outputs and internal logic		Cable length	
Supply voltage (L3+)		• Unshielded	Max. 100 m (328 ft.)
• Rated value	24 V DC	Setting of a digital input	Possible
• Permissible range	18.5 to 30.2 V		
• Value for t < 0.5 s	35 V		
Current consumption from L3+			
• Logic	Typ. 130 mA		
I ² t (for inrush current)	≤ 0.05 A ² s		

* In operation with the IM 308-B, the maximum baud rate is 1500 kbaud.

7.3.7 Electronics Block ET 200B-8DI/8DO (6ES7 133-0BH01-0XB0)

Characteristics The ET 200B-8DI/8DO electronics block has the following characteristics:

- 8 inputs, non-floating
- 8 outputs, non-floating
- Input voltage: 24 V DC
- Input delay: 3 ms
- Load voltage: 24 V DC
- Possible terminal blocks: TB1/DC, TB1-4/DC or TB3/DC

Dimensional Drawing See Figure 7-18 for the precise dimensions.

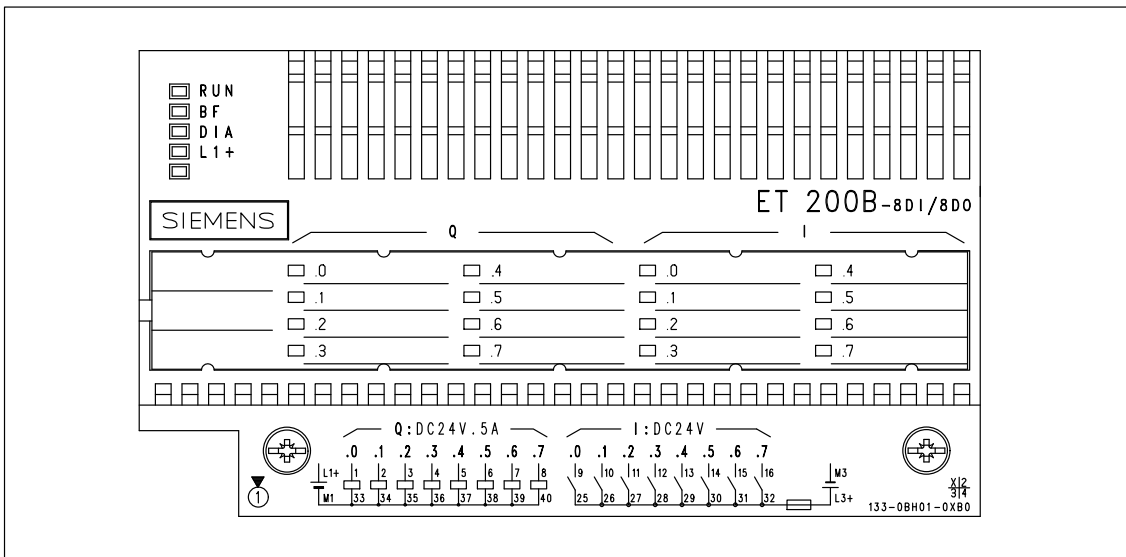

Figure 7-38 Front Elevation: ET 200B-8DI/8DO (6ES7 133-0BH01-0XB0)

Block Diagram

Simplified diagram of potential for the ET 200B-8DI/8DO and TB1/DC or TB3/DC:

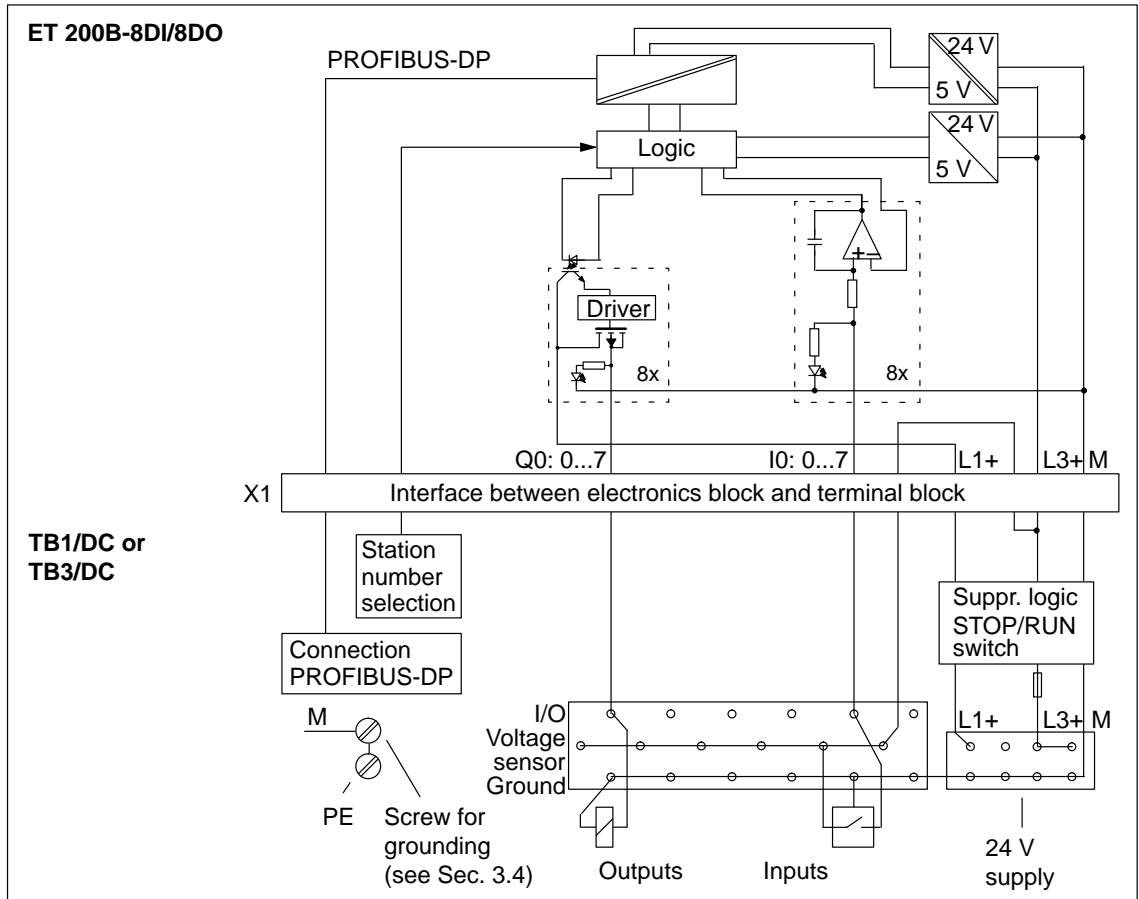

Figure 7-39 Block Diagram: ET 200B-8DI/8DO (6ES7 133-0BH01-0XB0) and TB1/DC or TB3/DC

Block Diagram

Simplified diagram of the potential for the ET 200B-8DI/8DO and TB1-4/DC:

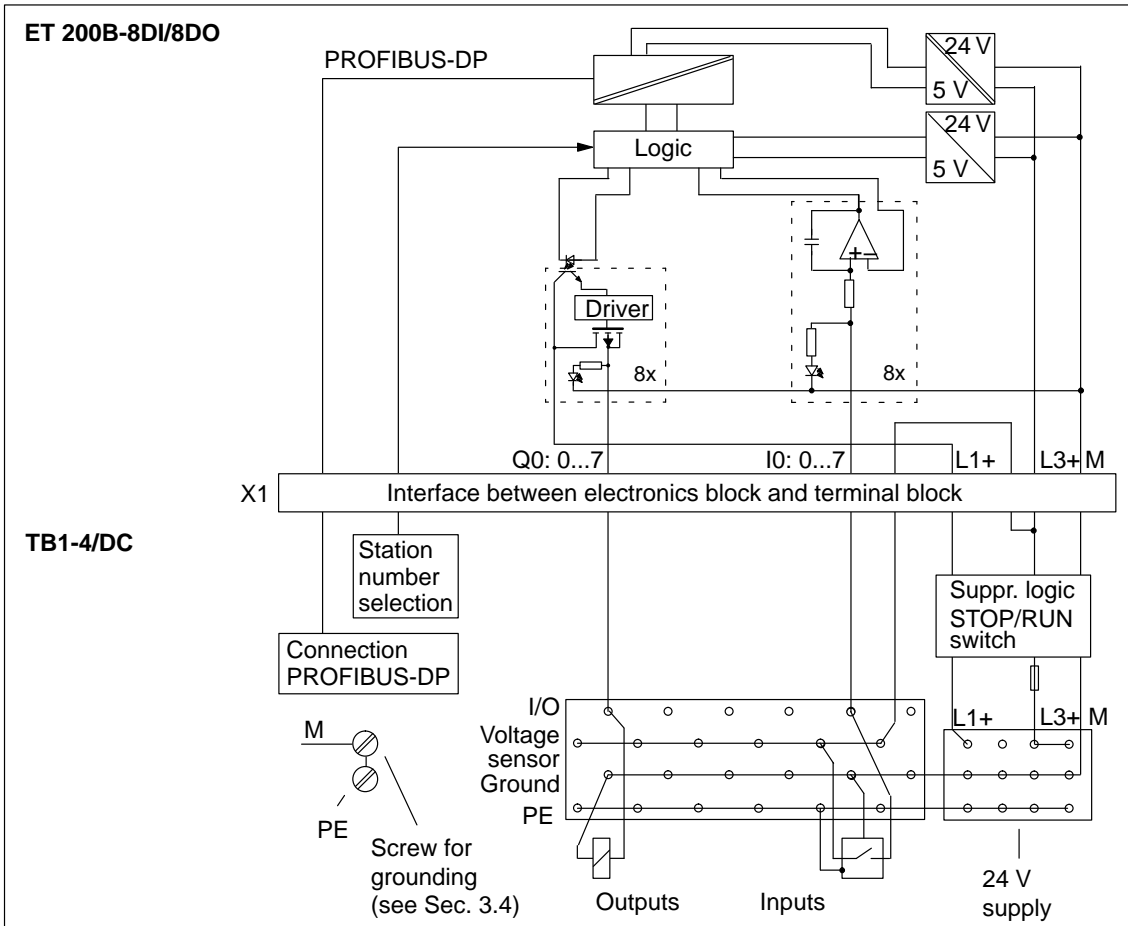

Figure 7-40 Block Diagram: ET 200B-8DI/8DO (6ES7 133-0BH01-0XB0) and TB1-4/DC

Pin Assignment

The table below shows the pin assignment of the terminal blocks for ET 200B-8DI/8DO. For the sake of clarity, the table also shows the terminal numbering of the terminal blocks, taking the TB1-4/DC by way of example.

Table 7-9 Pin Assignment of Terminal Blocks TB1/DC; TB1-4/DC and TB3/DC for ET 200B-8DI/8DO (6ES7 133-0BH01-0XB0)

Terminal tier 1	Terminal tier 2	Terminal tier 3	Terminal tier 4 ¹
1 Q0: Output .0	17 24 V (sensor voltage, internally jumpered, connected to L3+)	33 Ground (outputs) (internally jumpered, connected to M1, M2, M3)	⊕ PE (internally jumpered, but not connected to PE screw)
2 Q0: Output .1	18	34	⊕
3 Q0: Output .2	19	35	⊕
4 Q0: Output .3	20	36	⊕
5 Q0: Output .4	21	37	⊕
6 Q0: Output .5	22	38	⊕
7 Q0: Output .6	23	39	⊕
8 Q0: Output .7	24	40	⊕
9 I0: Input .0	25	41 Ground (sensor voltage) (internally jumpered, connected to M1, M2, M3)	⊕
10 I0: Input .1	26	42	⊕
11 I0: Input .2	27	43	⊕
12 I0: Input .3	28	44	⊕
13 I0: Input .4	29	45	⊕
14 I0: Input .5	30	46	⊕
15 I0: Input .6	31	47	⊕
16 I0: Input .7	32	48	⊕
-	L1+ Voltage supply L1+ for channel group Q0: .0 to .7	M1 Ground supply M1 for channel group Q0: .0 to .7	⊕ PE (internally jumpered, but not connected to PE screw)
-	L2+ not used	M2 not used	⊕
-	L3+ Voltage supply, internal logic and sensor voltage 24 V	M3 Ground connection, internal logic and sensor voltage	⊕
-	L3+ Voltage supply, internal logic and sensor voltage 24 V	M3 Ground connection, internal logic and sensor voltage	⊕

¹ TB1-4/DC only

Important Note on Wiring

The following notes are important as regards the wiring of the ET 200B-8DI/8DO:

- The terminals for PE on the 4-tier terminal block are not connected to the PE connection of terminal block TB1-4/DC.
- L1+ and L3+ are **not** internally interconnected.
- L3+ and terminals 25 ... 32 are interconnected, as are M1, M2, M3 and terminals 33 ... 48.
- The two L3+ terminals are also interconnected.

Fuse

The 24 V sensor supply is protected by fuse F1 (1.6 A) in the terminal blocks. Nevertheless, make sure that the current does not exceed the specifications in the technical data for the electronics block.

Technical Data

The technical data of electronics block ET 200B-8DI/8DO is listed in the tables below.

Technical specifications		Inputs, continued	
Baud rates*	9.6/19.2/93.75/187.5/500/ 1500/3000/6000/ 12000 kbaud	Input current for "1" signal	Typ. 4 mA at 24 V Min. 2 mA
Bus protocol	PROFIBUS-DP	Delay of inputs	3 ms
FREEZE and SYNC capability	Yes	Connection of 2-wire BERO	Possible
Galvanic isolation to SI-NEC L2-DP bus	Yes	• Quiescent current	≤ 1.5 mA
Power losses	Max. 3.8 W	Connection of mechanical switches	Possible
Weight (EB and TB)	Approx. 650 g (22.75 oz.)	Cable length of sensors	
Dimensions (EB and TB: W x H x D)	160 x 130 x 60 mm (6.24 x 5.07 x 2.34 in.)	• Unshielded	Max. 100 m (328 ft.)
Diagnostics functions		Outputs	
Voltage monitoring	Green "RUN" LED	Number of outputs	8
Bus monitoring SINEC L2-DP	Red "BF" LED	Galvanic isolation	No
Group diagnostics for short-circuit, load voltage failure	Red "DIA" LED	• In groups of	8
Load voltage monitoring	Green "L1+" LED	Output voltage	
Status of inputs and outputs	Green LEDs	• For "0" signal	Max. 2 V (idle)
		• For "1" signal	Min. (supply voltage – 3 V)
		Output current	
		• For "0" signal	Max. 1 mA
		• For "1" signal	Max. 0.5 A
		Delay of outputs	
		• From "0" to "1"	Approx. 20 μs
		• From "1" to "0"	Max. 0.5 ms
		Switching frequency	
		• Resistive load	Max. 100 Hz
		• Inductive load	Max. 0.5 Hz
		• Lamp load	Max. 8 Hz
		Short-circuit protection	Yes
		Load current	
		• Total current	Max. 2 A
		Lamp load	Max. 5 W
		Setting a digital input	Possible
		Limit of inductive cutoff voltage	Typ. (L1+) – 55 V
		Cable length	Max. 100 m (328 ft.)
Supply voltage for sensor supply, load voltage supply and internal logic			
Supply voltage (L1+,L3+)			
• Rated value	24 V DC		
• Permissible range	18.5 to 30.2 V		
• Value for t < 0.5 s	35 V		
Current consumption from L3+			
• Logic	Typ. 70 mA		
• Sensors	Max. 500 mA		
I ² t (for inrush current)	≤ 0.05 A ² s		
Inputs			
Number of inputs	8		
Galvanic isolation to internal electronic circuits	No		
Input voltage			
• Rated value	24 V DC		
• For "0" signal	– 30 V to 5 V		
• For "1" signal	13 V to 30 V		

* In operation with the IM 308-B, the maximum baud rate is 1500 kbaud.

7.3.8 Electronics Block ET 200B-8DI/8DO HWA (6ES7 133-0BH10-0XB0)

characteristics The ET 200B-8DI/8DO HWA electronics block has the following characteristics:

- 8 inputs, non-floating
- 8 outputs, non-floating
- The outputs can be deactivated by a programmed deactivation level applied to the input.
- Input voltage: 24 V DC
- Input delay: 3 ms
- Load voltage: 24 V DC
- Possible terminal blocks: TB1/DC, TB1-4/DC or TB3/DC

Dimensional Drawing See Figure 7-18 for the precise dimensions.

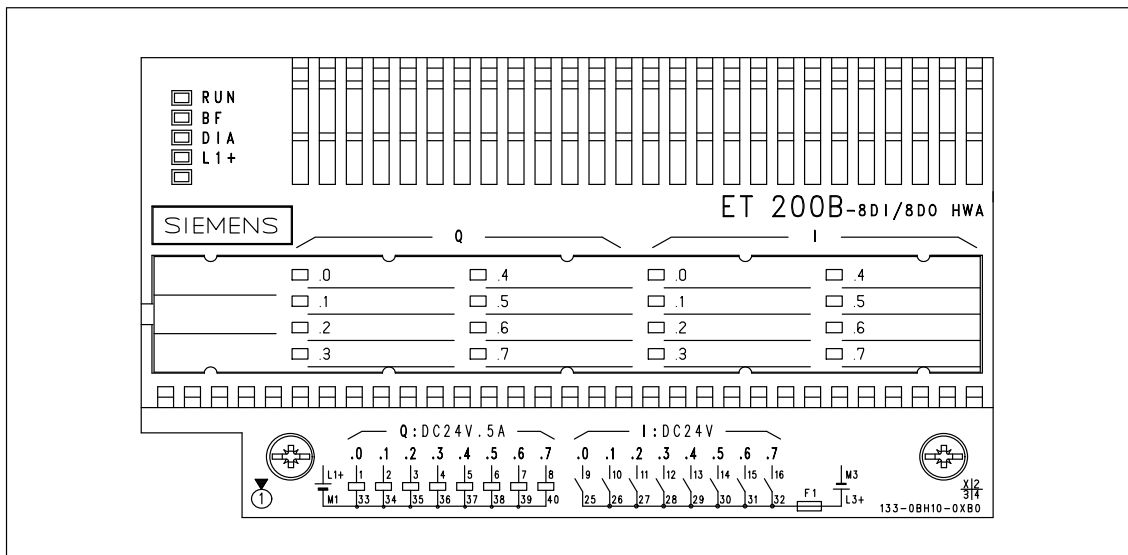

Figure 7-41 Front Elevation: ET 200B-8DI/8DO HWA (6ES7 133-0BH10-0XB0)

Block Diagram

Simplified diagram of potential for the ET 200B-8DI/8DO HWA and TB1/DC or TB3/DC:

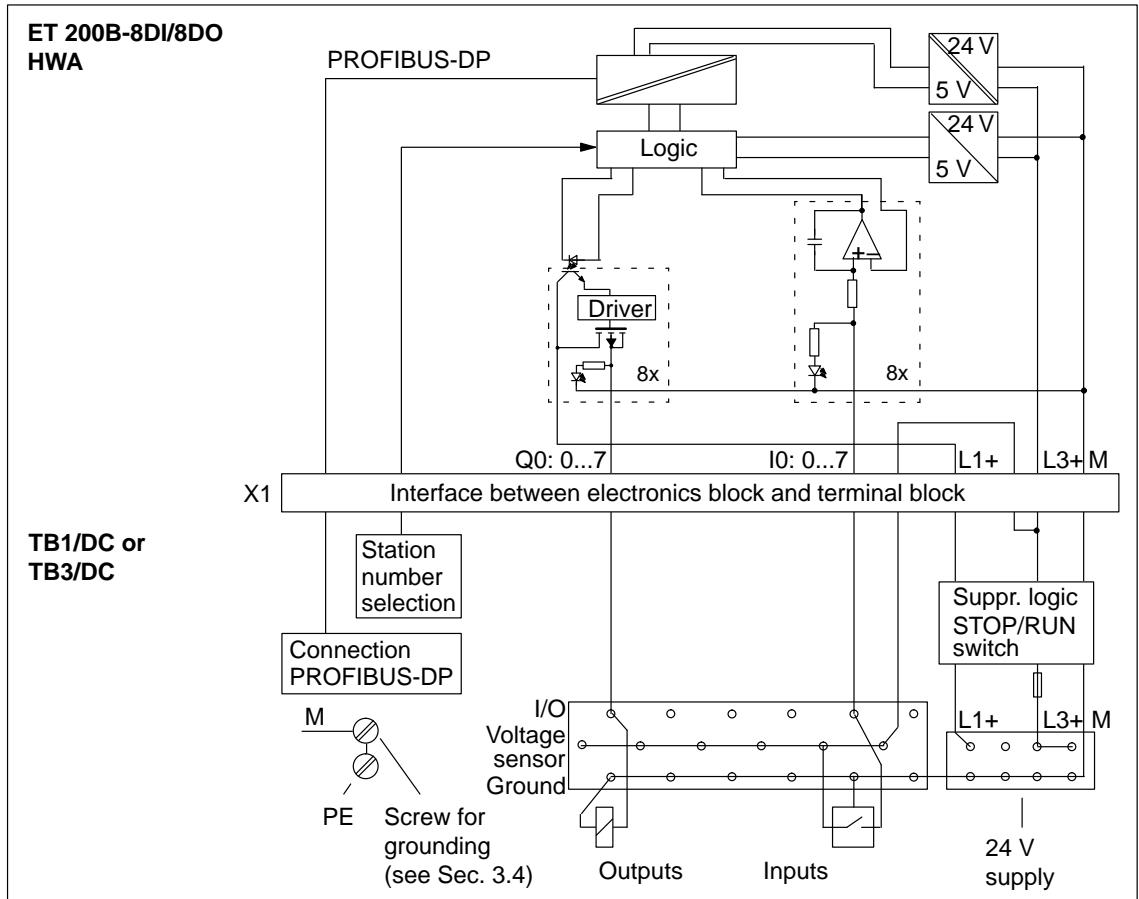

Figure 7-42 Block Diagram: ET 200B-8DI/8DO HWA (6ES7 133-0BH10-0XB0) and TB1/DC or TB3/DC

Block Diagram

Simplified diagram of potential for the ET 200B-8DI/8DO HWA and TB1-4/DC:

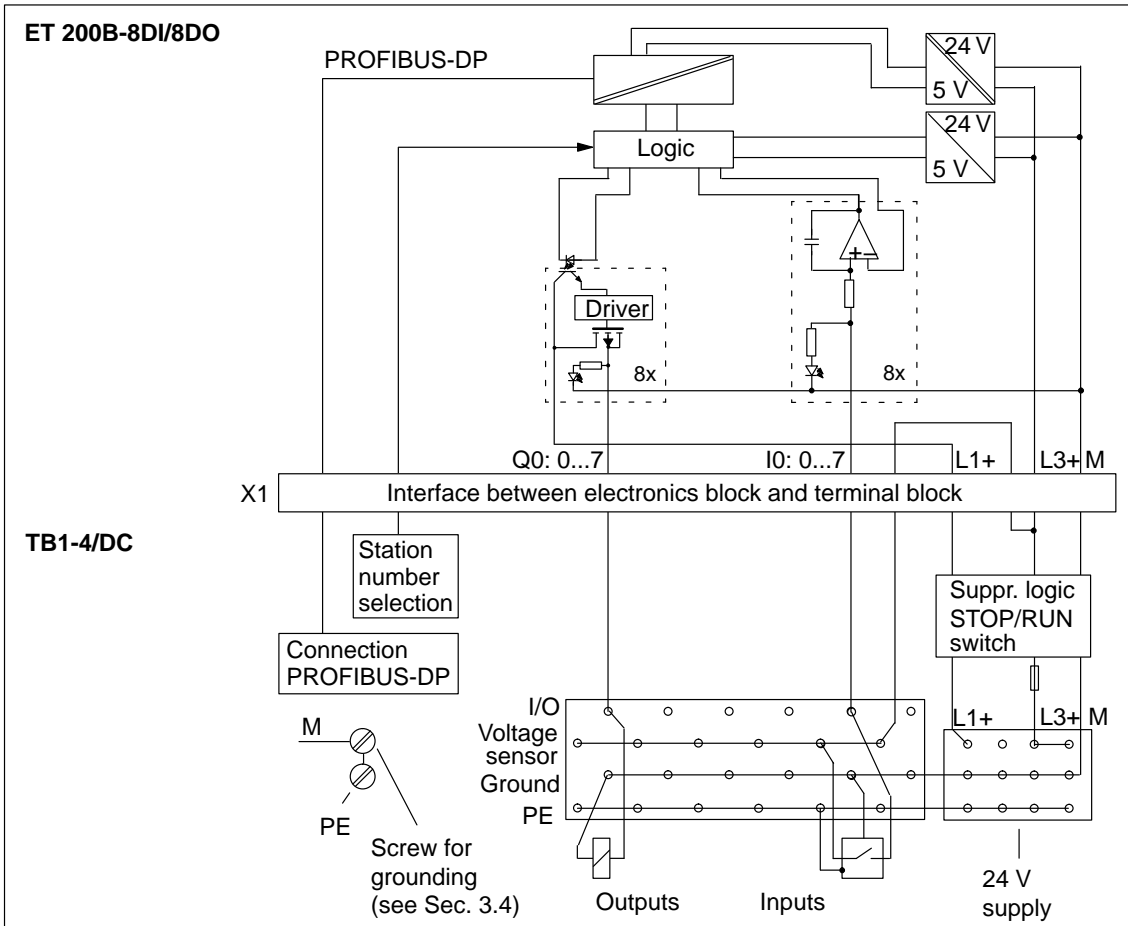
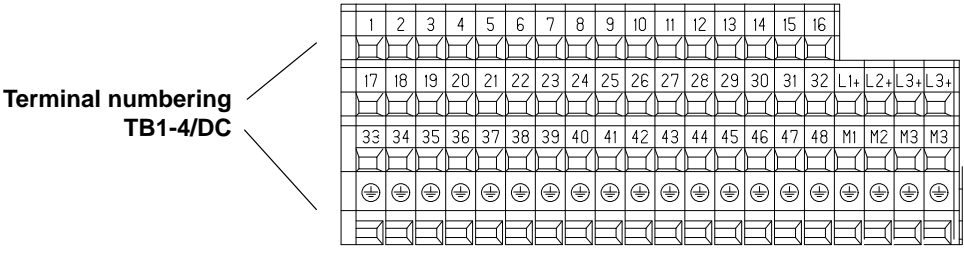

Figure 7-43 Block Diagram: ET 200B-8DI/8DO HWA (6ES7 133-0BH10-0XB0) and TB1-4/DC

Pin Assignment

The table below shows the pin assignment of the terminal blocks for ET 200B-8DI/8DO HWA. For the sake of clarity, the table also shows the terminal numbering of the terminal blocks, taking the TB1-4/DC by way of example.

Table 7-10 Pin Assignment of Terminal Blocks TB1/DC; TB1-4/DC and TB3/DC for ET 200B-8DI/8DO HWA (6ES7 133-0BH10-0XB0)



Terminal tier 1	Terminal tier 2	Terminal tier 3	Terminal tier 4 ¹	
1 Q0: Output .0	24 V (sensor voltage, internally jumpered, connected to L3+)	33	Ground (outputs) (internally jumpered, connected to M1, M2, M3)	
2 Q0: Output .1		34		
3 Q0: Output .2		35		
4 Q0: Output .3		36		
5 Q0: Output .4		37		
6 Q0: Output .5		38		
7 Q0: Output .6		39		
8 Q0: Output .7		40		
9 I0: Input .0		41		Ground (sensor voltage) (internally jumpered, connected to M1, M2, M3)
10 I0: Input .1		42		
11 I0: Input .2		43		
12 I0: Input .3		44		
13 I0: Input .4		45		
14 I0: Input .5		46		
15 I0: Input .6		47		
16 I0: Input .7		48		
–	L1+ Voltage supply L1+ for channel group Q0: .0 to .7	M1	Ground supply M1 for channel group Q0: .0 to .7	
–	L2+ not used	M2		not used
–	L3+ Voltage supply, internal logic and sensor voltage 24 V	M3		Ground connection, internal logic and sensor voltage
–	L3+ Voltage supply, internal logic and sensor voltage 24 V	M3		
			PE (internally jumpered, but not connected to PE screw)	

¹ TB1-4/DC only

HW Cutoff

Outputs .0 to .7 are deactivated as soon as the programmed cutoff level is applied to the corresponding input .0 to .7. The relationship between inputs and outputs is permanent (I .0 → O .0, I .1 → O .1, ...).

Address assignment:

EB x	Inputs .0 to .7	} 2 consecutive bytes in the address space of the CPU
AB y	Outputs .0 to .7	
AB y + 1	Cutoff level .0 to .7 (negated)	

Bit Assignment in the "Cutoff Level" Byte

The "cutoff level" byte defaults to "0", i.e. output y.n is deactivated (set to "0"), if signal "1" is present at input x.n.

- 0: Output is deactivated by signal "1" at corresponding input.
- 1: Output is deactivated by signal "1" at corresponding input

Table 7-11 Truth Table for Hardware Cutoff of ET 200B-8DI/8DO HWA

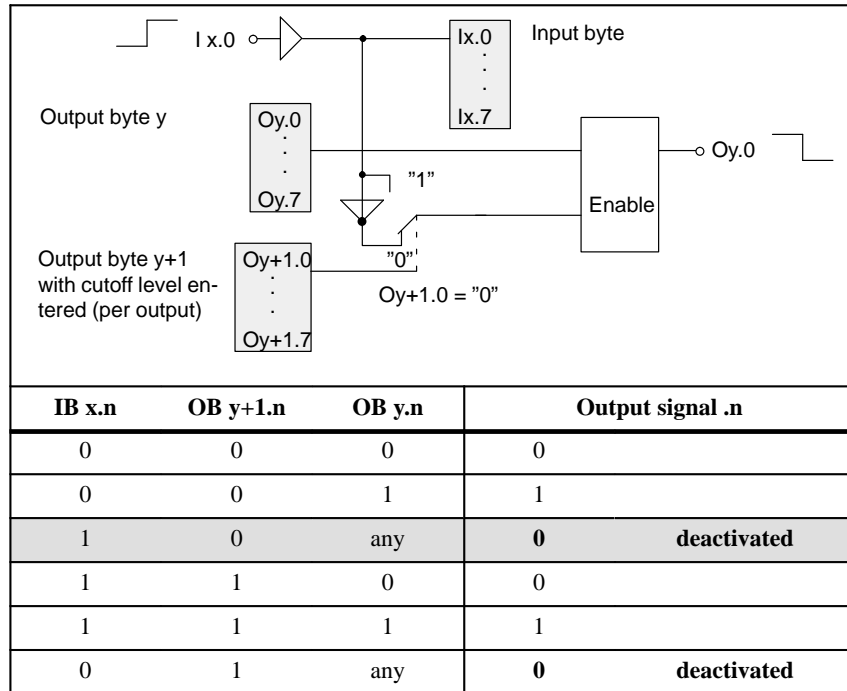

Note

The following notes are important as regards the wiring and hardware cutoff of ET 200B-8DI/8DO HWA:

- The terminals for PE on the 4-tier terminal block are not connected to the PE connection of terminal block TB1-4/DC.
- L1+ and L3+ are **not** internally interconnected.
- L3+ and terminals 17 ... 32 are interconnected, as are M1, M2, M3 and terminals 33 ... 48.
- The two L3+ terminals are also interconnected.
- Outputs can switch through temporarily:



Warning

The configuration described below is such that POWER OFF, STOP or transient voltage collapse at the terminal block cause the outputs of the ET 200B-8DI/8DO HWA to switch through briefly.

Case 3 in Table 7-11 "Truth Table" (gray background):
"cutoff level" byte OB y+1" programmed to "0", outputs set to "1" by S5/S7 application program. → signal "1" at input I x.n activates the hardware cut-off.

Cause: POWER OFF, STOP or transient voltage collapse shuts off the sensor voltage, but the logic continues to function for at least another 20 ms (bridging power failure). The lack of the sensor voltage means that signal "0" is detected at the inputs and the outputs are enabled if the configuration is as described above.

Fuse

The 24 V sensor supply is protected by fuse F1 (1.6 A) in the terminal blocks. Nevertheless, make sure that the current does not exceed the specifications in the technical data for the electronics block.

Technical Data

The technical data of electronics block ET 200B-8DI/8DO HWA is listed in the tables below.

Technical Data		Inputs (continued)	
Baud rates*	9.6/19.2/93.75/187.5/500/ 1500/3000/6000/ 12000 kbaud	Input current for "1" signal	Typ. 4 mA at 24 V Min. 2 mA
Bus protocol	PROFIBUS-DP	Delay of inputs	3 ms
FREEZE and SYNC capability	Yes	Connection of 2-wire BERO	Possible
Galvanic isolation to SI- NEC L2-DP bus	Yes	• Quiescent current	≤ 1.5 mA
Power losses	Max. 3.8 W	Connection of mechanical switches	Possible
Weight (EB and TB)	Approx. 650 g	Cable length of sensors	
Dimensions (EB and TB: W x H x D)	160 x 130 x 60	• Unshielded	Max. 100 m (328 ft.)
Diagnostics functions		Outputs	
Voltage monitoring	Green "RUN" LED	Number of outputs	8
Bus monitoring SINEC L2-DP	Red "BF" LED	Galvanic isolation	No
Group diagnostics for short-circuit, load voltage failure	Red "DIA" LED	• In groups of	8
Load voltage monitoring	Green "L1+" LED	Output voltage	
Status of inputs and out- puts	Green LEDs	• For "0" signal	Max. 2 V (idle)
		• For "1" signal	Min. (supply voltage – 3 V)
Supply voltage for sensor supply, load voltage supply and internal logic		Output current	
Supply voltage (L1+,L3+)		• For "0" signal	Max. 1 mA
• Rated value	24 V DC	• For "1" signal	Max. 0.5 A
• Permissible range	18.5 ... 30.2 V	Delay of outputs	
• Value for t < 0.5 s	35 V	• From "0" to "1"	Typ. 50 µs
Current consumption from L3+		• From "1" to "0"	Typ. 100 µs
• Logic	Typ. 70 mA	• By hardware cutoff	3 ms
• Sensors	Max. 500 mA	Switching frequency	
I ² t (for the inrush current)	≤ 0.05 A ² s	• Resistive load	Max. 100 Hz
		• Inductive load	Max. 0.5 Hz
		• Lamp load	Max. 8 Hz
		Short-circuit protection	Yes
		Load current	
		• Total current	Max. 2 A
		Lamp load	Max. 5 W
		Setting a digital input	Possible
		Limit of inductive cutoff voltage	Typ. (L1+) – 55 V
		Cable length	Max. 100 m (328 ft.)
Inputs			
Number of inputs	8		
Galvanic isolation to inter- nal electronic circuits	No		
Input voltage			
• Rated value	24 V DC		
• For "0" signal	– 30 V ... 5 V		
• For "1" signal	13 V ... 30 V		

* In operation with the IM 308-B, the maximum baud rate is 1500 kbaud.

7.3.9 Electronics Block ET 200B-16DI/16DO (6ES7 133 0BL00-0XB0)

Characteristics

The ET 200B-16DI/16DO has the following characteristics:

- 16 inputs, non-floating
- 16 outputs, floating in groups of 8
- Input voltage: 24 V DC
- Input delay: 3 ms
- Load voltage: 24 V DC
- Possible terminal blocks: TB2/DC, TB2-4/DC, TB4/DC, TB4M/DC

Dimensional Drawing

See Figure 7-22 for the precise dimensions.

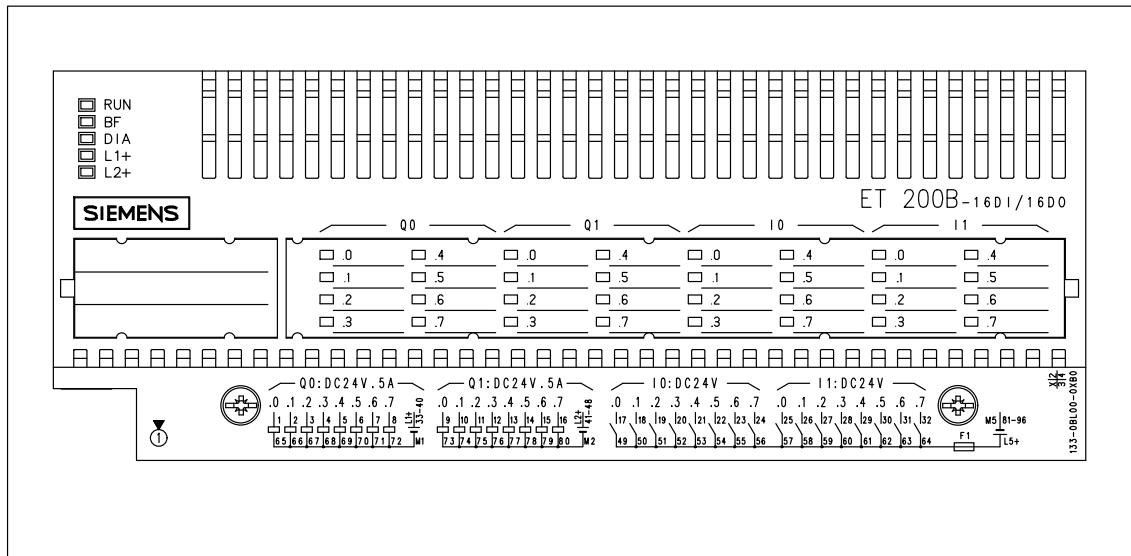

Figure 7-44 Front Elevation: ET 200B-16DI/16DO (6ES7 133-0BL00-0XB0)

Block Diagram

Simplified diagram of the potential for the ET 200B-16DI/16DO and TB2/DC or TB4/DC:

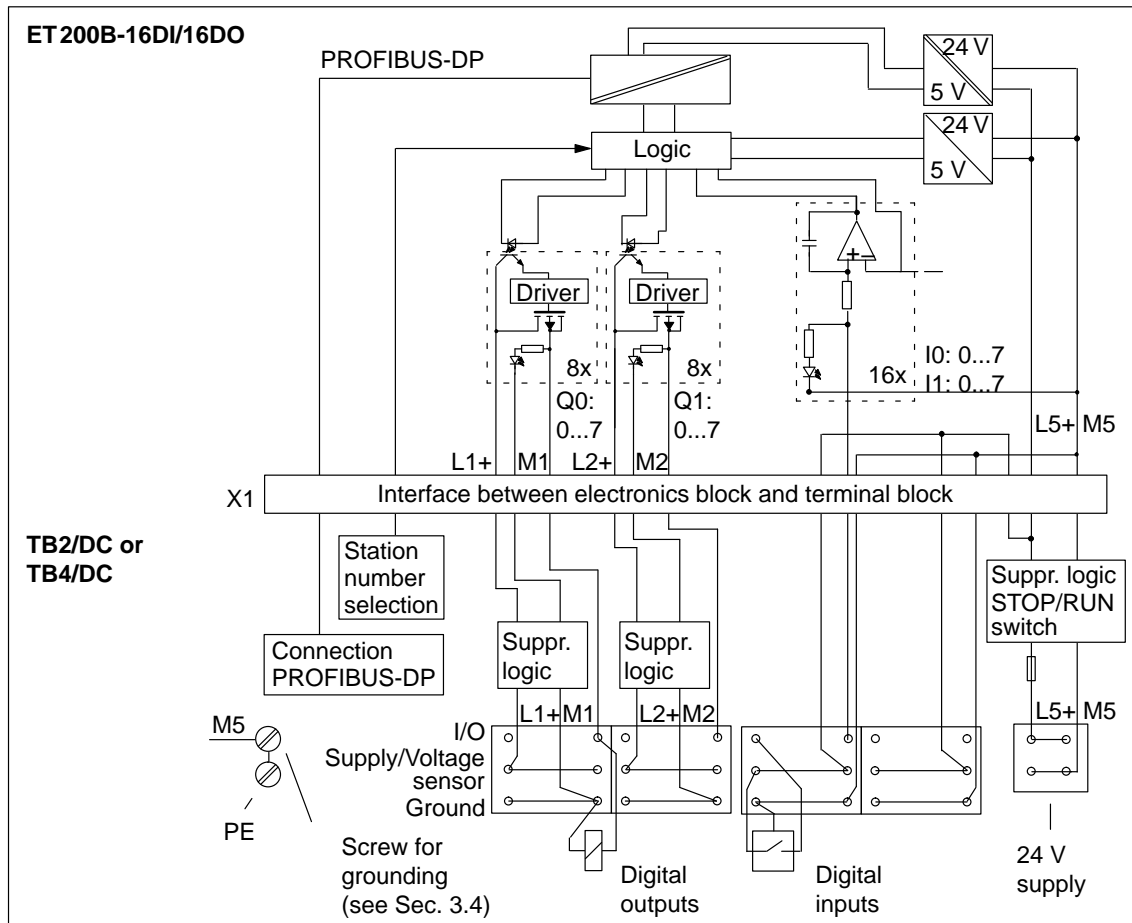

Figure 7-45 Block Diagram: ET 200B-16DI/16DO (6ES7 133-0BL00-0XB0) and TB2/DC or TB4/DC

Block Diagram

Simplified diagram of the potential for the ET 200B-16DI/16DO and TB2-4/DC:

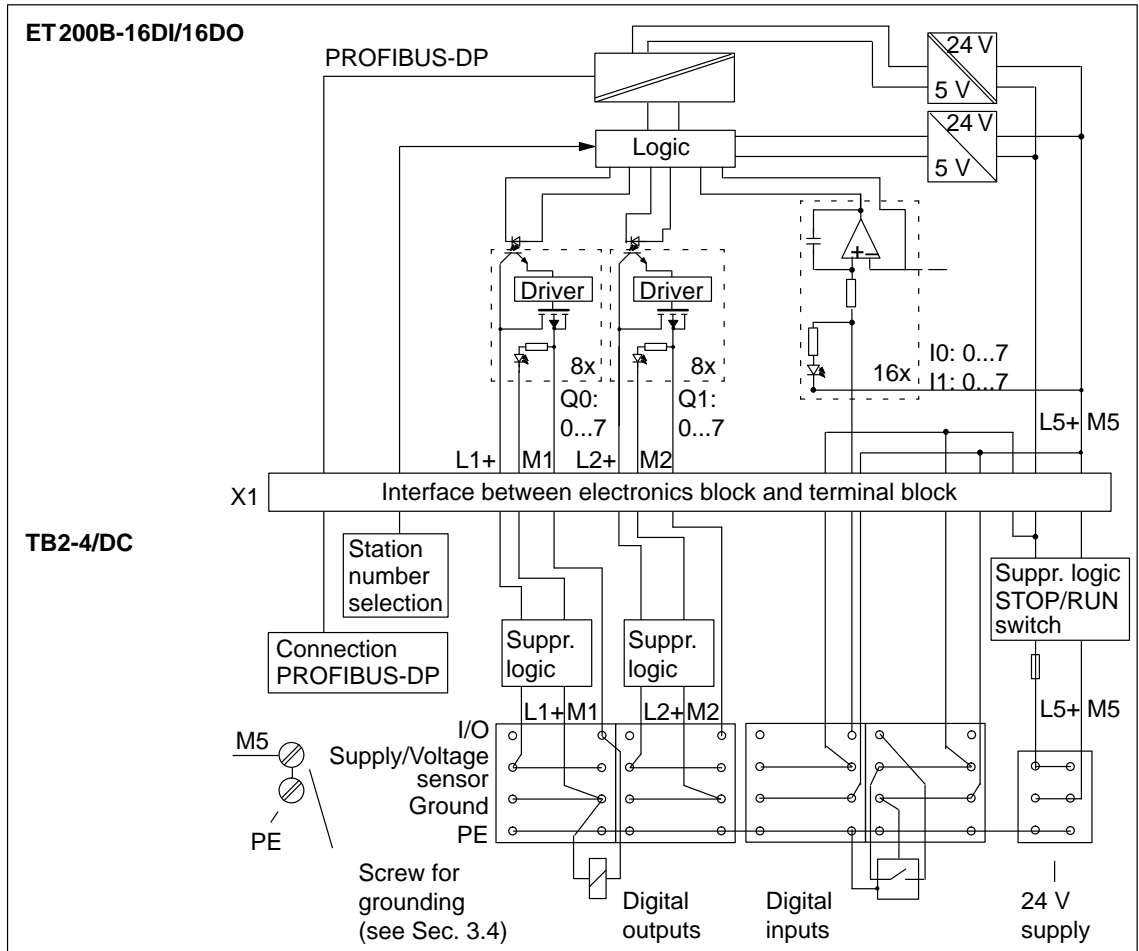

Figure 7-46 Block Diagram: ET 200B-16DI/16DO (6ES7 133-0BL00-0XB0) and TB2-4/DC

Pin Assignment

The table below shows the pin assignment of the terminal blocks for ET 200B-16DI/16DO. For the sake of clarity, the table also shows the terminal numbering of the terminal blocks, taking the TB2-4/DC by way of example.

Table 7-12 Pin Assignment of Terminal Blocks TB2/DC, TB2-4/DC, TB4/DC and TB4M/DC for ET 200B-16DI/16DO (6ES7 133-0BL00-0XB0)

Terminal numbering TB2-4/DC																																																																																																																																															
1	2	3	4	5	6	7	8	9	10	11	12	13	14	15	16	17	18	19	20	21	22	23	24	25	26	27	28	29	30	31	32																																																																																																																
33	34	35	36	37	38	39	40	41	42	43	44	45	46	47	48	49	50	51	52	53	54	55	56	57	58	59	60	61	62	63	64	L5+	L5+																																																																																																														
65	66	67	68	69	70	71	72	73	74	75	76	77	78	79	80	81	82	83	84	85	86	87	88	89	90	91	92	93	94	95	96	M5	M5																																																																																																														
<table border="1"> <thead> <tr> <th>Terminal tier 1</th> <th>Terminal tier 1</th> <th>Terminal tier 3</th> <th>Terminal tier 4¹</th> </tr> </thead> <tbody> <tr> <td>1 Q0: Output .0</td> <td>33</td> <td rowspan="8">Voltage supply L1+ for channel group Q0: .0 to .7</td> <td>65</td> <td rowspan="8">Ground supply M1 for channel group Q0: .0 to .7</td> <td>⊕</td> <td rowspan="8">PE (internally jumpered, but not connected to PE screw)</td> </tr> <tr> <td>2 Q0: Output .1</td> <td>34</td> <td>66</td> <td>⊕</td> </tr> <tr> <td>3 Q0: Output .2</td> <td>35</td> <td>67</td> <td>⊕</td> </tr> <tr> <td>4 Q0: Output .3</td> <td>36</td> <td>68</td> <td>⊕</td> </tr> <tr> <td>5 Q0: Output .4</td> <td>37</td> <td>69</td> <td>⊕</td> </tr> <tr> <td>6 Q0: Output .5</td> <td>38</td> <td>70</td> <td>⊕</td> </tr> <tr> <td>7 Q0: Output .6</td> <td>39</td> <td>71</td> <td>⊕</td> </tr> <tr> <td>8 Q0: Output .7</td> <td>40</td> <td>72</td> <td>⊕</td> </tr> <tr> <td>9 Q1: Output .0</td> <td>41</td> <td rowspan="8">Voltage supply L2+ for channel group Q1: .0 to .7</td> <td>73</td> <td rowspan="8">Ground supply M2 for channel group Q0: .0 to .7</td> <td>⊕</td> <td rowspan="8"></td> </tr> <tr> <td>10 Q1: Output .1</td> <td>42</td> <td>74</td> <td>⊕</td> </tr> <tr> <td>11 Q1: Output .2</td> <td>43</td> <td>75</td> <td>⊕</td> </tr> <tr> <td>12 Q1: Output .3</td> <td>44</td> <td>76</td> <td>⊕</td> </tr> <tr> <td>13 Q1: Output .4</td> <td>45</td> <td>77</td> <td>⊕</td> </tr> <tr> <td>14 Q1: Output .5</td> <td>46</td> <td>78</td> <td>⊕</td> </tr> <tr> <td>15 Q1: Output .6</td> <td>47</td> <td>79</td> <td>⊕</td> </tr> <tr> <td>16 Q1: Output .7</td> <td>48</td> <td>80</td> <td>⊕</td> </tr> <tr> <td>17 I0: Input .0</td> <td>49</td> <td rowspan="8">24 V (sensor voltage) (internally jumpered, connected to L5+)</td> <td>81</td> <td rowspan="8">Ground (sensor voltage) (internally jumpered, connected to M5)</td> <td>⊕</td> <td rowspan="8"></td> </tr> <tr> <td>18 I0: Input .1</td> <td>50</td> <td>82</td> <td>⊕</td> </tr> <tr> <td>19 I0: Input .2</td> <td>51</td> <td>83</td> <td>⊕</td> </tr> <tr> <td>20 I0: Input .3</td> <td>52</td> <td>84</td> <td>⊕</td> </tr> <tr> <td>21 I0: Input .4</td> <td>53</td> <td>85</td> <td>⊕</td> </tr> <tr> <td>22 I0: Input .5</td> <td>54</td> <td>86</td> <td>⊕</td> </tr> <tr> <td>23 I0: Input .6</td> <td>55</td> <td>87</td> <td>⊕</td> </tr> <tr> <td>24 I0: Input .7</td> <td>56</td> <td>88</td> <td>⊕</td> </tr> <tr> <td>25 I1: Input .0</td> <td>57</td> <td rowspan="4"></td> <td>89</td> <td rowspan="4"></td> <td>⊕</td> <td rowspan="4"></td> </tr> <tr> <td>26 I1: Input .1</td> <td>58</td> <td>90</td> <td>⊕</td> </tr> <tr> <td>27 I1: Input .2</td> <td>59</td> <td>91</td> <td>⊕</td> </tr> <tr> <td>28 I1: Input .3</td> <td>60</td> <td>92</td> <td>⊕</td> </tr> </tbody> </table>																Terminal tier 1	Terminal tier 1	Terminal tier 3	Terminal tier 4 ¹	1 Q0: Output .0	33	Voltage supply L1+ for channel group Q0: .0 to .7	65	Ground supply M1 for channel group Q0: .0 to .7	⊕	PE (internally jumpered, but not connected to PE screw)	2 Q0: Output .1	34	66	⊕	3 Q0: Output .2	35	67	⊕	4 Q0: Output .3	36	68	⊕	5 Q0: Output .4	37	69	⊕	6 Q0: Output .5	38	70	⊕	7 Q0: Output .6	39	71	⊕	8 Q0: Output .7	40	72	⊕	9 Q1: Output .0	41	Voltage supply L2+ for channel group Q1: .0 to .7	73	Ground supply M2 for channel group Q0: .0 to .7	⊕		10 Q1: Output .1	42	74	⊕	11 Q1: Output .2	43	75	⊕	12 Q1: Output .3	44	76	⊕	13 Q1: Output .4	45	77	⊕	14 Q1: Output .5	46	78	⊕	15 Q1: Output .6	47	79	⊕	16 Q1: Output .7	48	80	⊕	17 I0: Input .0	49	24 V (sensor voltage) (internally jumpered, connected to L5+)	81	Ground (sensor voltage) (internally jumpered, connected to M5)	⊕		18 I0: Input .1	50	82	⊕	19 I0: Input .2	51	83	⊕	20 I0: Input .3	52	84	⊕	21 I0: Input .4	53	85	⊕	22 I0: Input .5	54	86	⊕	23 I0: Input .6	55	87	⊕	24 I0: Input .7	56	88	⊕	25 I1: Input .0	57		89		⊕		26 I1: Input .1	58	90	⊕	27 I1: Input .2	59	91	⊕	28 I1: Input .3	60	92	⊕
Terminal tier 1	Terminal tier 1	Terminal tier 3	Terminal tier 4 ¹																																																																																																																																												
1 Q0: Output .0	33	Voltage supply L1+ for channel group Q0: .0 to .7	65	Ground supply M1 for channel group Q0: .0 to .7	⊕	PE (internally jumpered, but not connected to PE screw)																																																																																																																																									
2 Q0: Output .1	34		66		⊕																																																																																																																																										
3 Q0: Output .2	35		67		⊕																																																																																																																																										
4 Q0: Output .3	36		68		⊕																																																																																																																																										
5 Q0: Output .4	37		69		⊕																																																																																																																																										
6 Q0: Output .5	38		70		⊕																																																																																																																																										
7 Q0: Output .6	39		71		⊕																																																																																																																																										
8 Q0: Output .7	40		72		⊕																																																																																																																																										
9 Q1: Output .0	41	Voltage supply L2+ for channel group Q1: .0 to .7	73	Ground supply M2 for channel group Q0: .0 to .7	⊕																																																																																																																																										
10 Q1: Output .1	42		74		⊕																																																																																																																																										
11 Q1: Output .2	43		75		⊕																																																																																																																																										
12 Q1: Output .3	44		76		⊕																																																																																																																																										
13 Q1: Output .4	45		77		⊕																																																																																																																																										
14 Q1: Output .5	46		78		⊕																																																																																																																																										
15 Q1: Output .6	47		79		⊕																																																																																																																																										
16 Q1: Output .7	48		80		⊕																																																																																																																																										
17 I0: Input .0	49	24 V (sensor voltage) (internally jumpered, connected to L5+)	81	Ground (sensor voltage) (internally jumpered, connected to M5)	⊕																																																																																																																																										
18 I0: Input .1	50		82		⊕																																																																																																																																										
19 I0: Input .2	51		83		⊕																																																																																																																																										
20 I0: Input .3	52		84		⊕																																																																																																																																										
21 I0: Input .4	53		85		⊕																																																																																																																																										
22 I0: Input .5	54		86		⊕																																																																																																																																										
23 I0: Input .6	55		87		⊕																																																																																																																																										
24 I0: Input .7	56		88		⊕																																																																																																																																										
25 I1: Input .0	57		89		⊕																																																																																																																																										
26 I1: Input .1	58		90		⊕																																																																																																																																										
27 I1: Input .2	59		91		⊕																																																																																																																																										
28 I1: Input .3	60		92		⊕																																																																																																																																										

Table 7-12 Pin Assignment of Terminal Blocks TB2/DC, TB2-4/DC, TB4/DC and TB4M/DC for ET 200B-16DI/16DO (6ES7 133-0BL00-0XB0), continued

Terminal tier 1		Terminal tier 1		Terminal tier 3		Terminal tier 4 ¹	
29	II: Input .4	61	24 V (sensor voltage) (internally jumpered, connected to L5+)	93	Ground (sensor voltage) (internally jumpered, connected to M5)	⊕	PE (internally jumpered, but not connected to PE screw)
30	II: Input .5	62		94		⊕	
31	II: Input .6	63		95		⊕	
32	II: Input .7	64		96		⊕	
-		L5+	Voltage supply, internal logic and sensor voltage 24 V	M5	Ground connection, internal logic and sensor voltage	⊕	PE (internally jumpered, but not connected to PE screw)
-		L5+	Voltage supply, internal logic and sensor voltage 24 V	M5	Ground connection, internal logic and sensor voltage	⊕	

¹ TB2-4/DC only; in the TB4M/DC tier 4 is available for additional ground connections (see Section 7.2.7)

Important Note on Wiring

The following notes are important as regards the wiring of the ET 200B-16DI/16DO:

- The terminals for PE on the 4-tier terminal block are not connected to the PE connection of terminal block TB2-4/DC.
- If all actuators are connected by two-wire cables to the TB2/DC, TB4/DC or TB2-4/DC, connect the ground of an actuator and the supply for the reference potential per group by means of a DIN 46231 cable cleat.
- L1+, L2+ and L5+ or M1, M2 and M5 are **not** interconnected.
- L5+ and terminals 49 ... 64 are interconnected, as are M5 and terminals 81 ... 96.
- The two L5+ terminals are also internally interconnected.

Fuse

The 24 V sensor supply is protected by fuse F1 (2.5 A) in the terminal blocks. Nevertheless, make sure that the current does not exceed the specifications in the technical data for the electronics block.

Technical Data

The technical data of electronics block ET 200B-16DI/16DO is listed in the tables below.

Technical Data		Inputs (continued)	
Baud rates*	9.6/19.2/93.75/187.5/500/ 1500/3000/6000/ 12000 kbaud	Input current For "1" signal	Typ. 4 mA at 24 V Min. 2 mA
Bus protocol	PROFIBUS-DP	Delay of inputs	3 ms
FREEZE and SYNC capability	Yes	Connection of 2-wire BERO	Possible
Galvanic isolation to SI- NEC L2-DP bus	Yes	• Quiescent current	≤ 1.5 mA
Power losses	Max. 5.5 W	Connection of mechanical switches	Possible
Weight (EB and TB)	Approx. 800 g (28 oz.)	Cable length of sensors	
Dimensions (EB and TB: W x H x D)	235 x 130 x 60	• Unshielded	Max. 100 m (328 ft.)
Diagnostics functions		Outputs	
Voltage monitoring	Green "RUN" LED	Number of outputs	16
Bus monitoring SINEC L2-DP	Red "BF" LED	Galvanic isolation	Yes
Group diagnostics for short-circuit, load voltage failure	Red "DIA" LED	• In groups of	8
Load voltage monitoring	Green "L1+/L2+" LEDs	Output voltage	
Status of inputs and out- puts	Green LEDs	• For "0" signal	Max. 2 V (idle)
		• For "1" signal	Min. (supply voltage – 3 V)
		Output current	
		• For "0" signal	Max. 1 mA
		• For "1" signal	Max. 0.5 A
		Delay of outputs	
		• From "0" to "1"	Approx. 20 μs
		• From "1" to "0"	Max. 0.5 ms
		Switching frequency	
		• Resistive load	Max. 1000 Hz
		• Inductive load	Max. 0.5 Hz
		• Lamp load	Max. 8 Hz
		Short-circuit protection	Yes
		Load current per group	
		• Total current	Max. 2 A
		Lamp load	Max. 5 W
		Setting a digital input	Possible
		Limit of inductive cutoff voltage	Typ. (L1+/L2+) – 55 V
		Cable length	Max. 100 m (328 ft.)
Supply voltage for outputs, load voltage supply and internal logic		* In operation with the IM 308-B, the maximum baud rate is 1500 kbaud.	
Supply voltages (L1+, L2+, L5+)			
• Rated value	24 V DC		
• Permissible range	18.5 ... 30.2 V		
• Value for t < 0.5 s	35 V		
Current consumption from L5+			
• Logic	Typ. 85 mA		
• Sensors	Max. 1 A		
I ² t (for inrush current)	≤ 0.05 A ² s		
Inputs			
Number of inputs	16		
Galvanic isolation to inter- nal electronic circuits	No		
Input voltage			
• Rated value	24 V DC		
• For "0" signal	– 30 V ... 5 V		
• For "1" signal	13 V ... 30 V		

7.3.10 Electronics Blocks ET 200B-24DI/8DO (6ES7 133-0BN01-0XB0) and ET 200B-24DI/8DO 0.2ms (6ES7 133-0BN11-0XB0)

Characteristics

The ET 200B-24DI/8DO and ET 200B-24DI/8DO 0.2ms electronics blocks have the following characteristics:

- 24 inputs, non-floating
- 8 outputs, floating in groups of 8
- Input voltage: 24 V DC
- Input delay:
 - 6ES7 133-0BN01-0XB0 → 3 ms
 - 6ES7 133-0BN11-0XB0 → 0.2 ms
- Load voltage: 24 V DC
- Possible terminal blocks: TB2/DC, TB2-4/DC, TB4/DC, TB4M/DC

Dimensional Drawing

See Figure 7-22 for the precise dimensions.

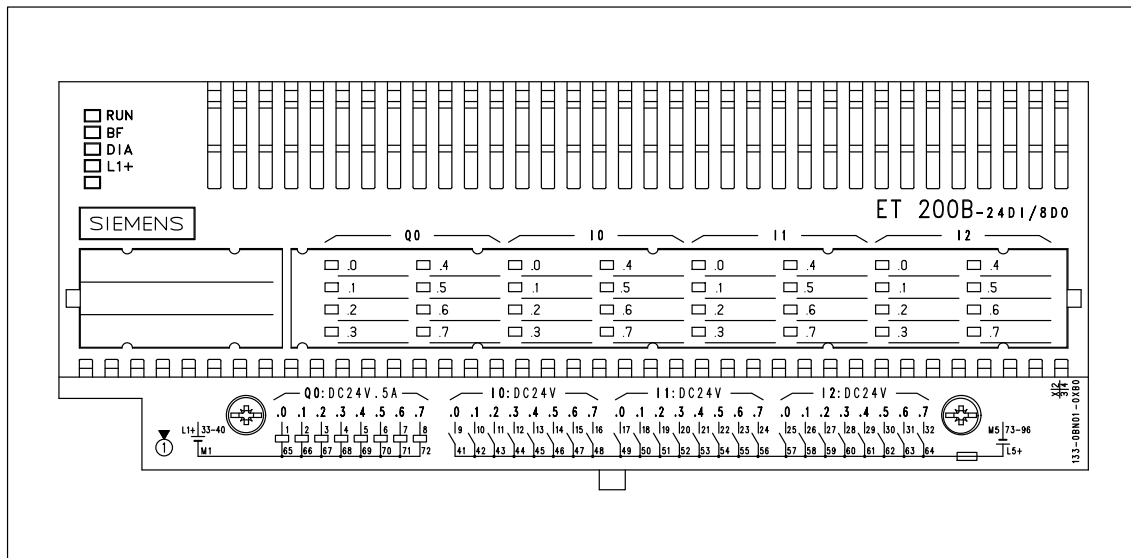

Figure 7-47 Front Elevation: ET 200B-24DI/8DO (6ES7 133-0BN01-0XB0) and ET 200B-24DI/8DO 0.2ms (6ES7 133-0BN11-0XB0)

Block Diagram

Simplified diagram of the potential for the ET 200B-24DI/8DO or ET 200B-24DI/8DO 0.2 ms and TB2/DC or TB4/DC:

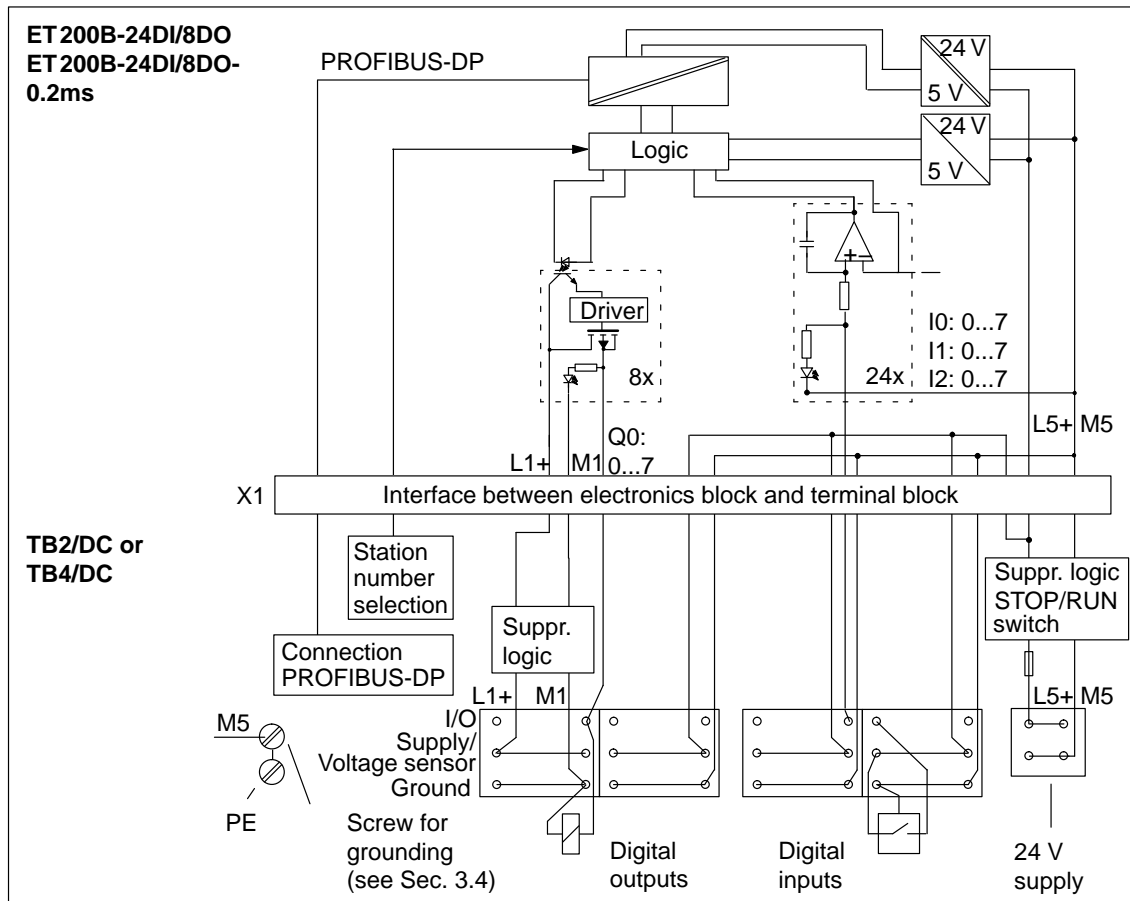

Figure 7-48 Block Diagram: ET 200B-24DI/8DO (6ES7 133-0BN01-0XB0) or ET 200B-24DI/8DO 0.2ms (6ES7 133-0BN11-0XB0) and TB2/DC or TB4/DC

Block Diagram

Simplified diagram of the potential for the ET 200B-24DI/8DO or ET 200B-24DI/8DO 0.2 ms and TB2-4/DC:

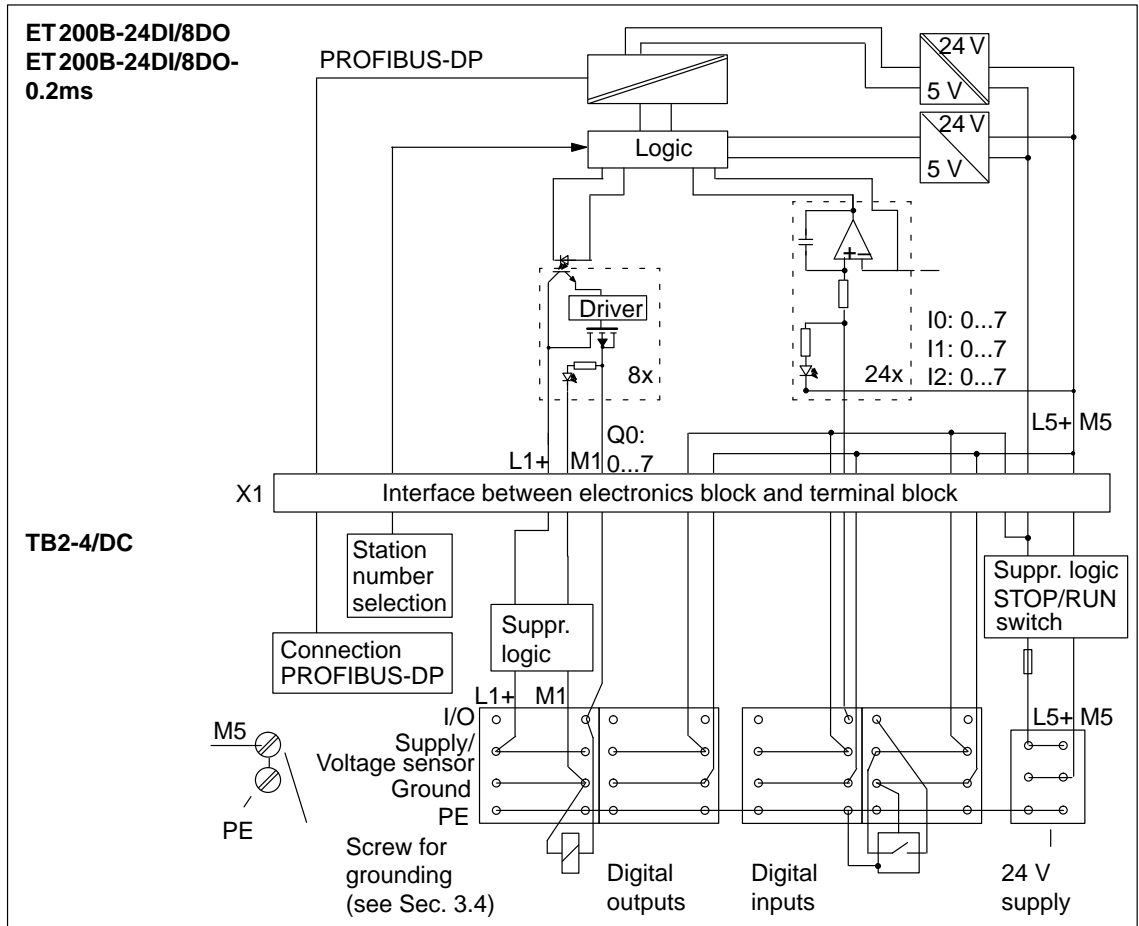

Figure 7-49 Block Diagram: ET 200B-24DI/8DO (6ES7 133-0BN01-0XB0) or ET 200B-24DI/8DO 0.2ms (6ES7 133-0BN11-0XB0) and TB2-4/DC

Pin Assignment

The table below shows the pin assignment of the terminal blocks for ET 200B-24DI/8DO and ET 200B-24DI/8DO 0.2 ms. For the sake of clarity, the table also shows the terminal numbering of the terminal blocks, taking the TB2-4/DC by way of example.

Table 7-13 Pin Assignment of Terminal Blocks TB2/DC; TB2-4/DC and TB4/DC for ET 200B-24DI/8DO (6ES7 133-0BN01-0XB0) and ET 200B-24DI/8DO 0.2ms (6ES7 133-0BN11-0XB0)

Terminal numbering TB2-4/DC																																																																																																																																																																							
1	2	3	4	5	6	7	8	9	10	11	12	13	14	15	16	17	18	19	20	21	22	23	24	25	26	27	28	29	30	31	32																																																																																																																																								
33	34	35	36	37	38	39	40	41	42	43	44	45	46	47	48	49	50	51	52	53	54	55	56	57	58	59	60	61	62	63	64	L5+	L5+																																																																																																																																						
65	66	67	68	69	70	71	72	73	74	75	76	77	78	79	80	81	82	83	84	85	86	87	88	89	90	91	92	93	94	95	96	M5	M5																																																																																																																																						
<table border="1"> <thead> <tr> <th>Terminal tier 1</th> <th>Terminal tier 2</th> <th>Terminal tier 3</th> <th>Terminal tier 4¹</th> </tr> </thead> <tbody> <tr> <td>1</td> <td>Q0: Output .0</td> <td>33</td> <td rowspan="8">Voltage supply L1+ for channel group Q0: .0 to .7</td> <td>65</td> <td rowspan="8">Ground M1 for channel group Q0: .0 to .7</td> <td>⊕</td> <td rowspan="8">PE (internally jump-ered, but not connected to PE screw)</td> </tr> <tr> <td>2</td> <td>Q0: Output .1</td> <td>34</td> <td>66</td> <td>⊕</td> </tr> <tr> <td>3</td> <td>Q0: Output .2</td> <td>35</td> <td>67</td> <td>⊕</td> </tr> <tr> <td>4</td> <td>Q0: Output .3</td> <td>36</td> <td>68</td> <td>⊕</td> </tr> <tr> <td>5</td> <td>Q0: Output .4</td> <td>37</td> <td>69</td> <td>⊕</td> </tr> <tr> <td>6</td> <td>Q0: Output .5</td> <td>38</td> <td>70</td> <td>⊕</td> </tr> <tr> <td>7</td> <td>Q0: Output .6</td> <td>39</td> <td>71</td> <td>⊕</td> </tr> <tr> <td>8</td> <td>Q0: Output .7</td> <td>40</td> <td>72</td> <td>⊕</td> </tr> <tr> <td>9</td> <td>I0: Input .0</td> <td>41</td> <td rowspan="8">24 V (sensor voltage, connected to L5+)</td> <td>73</td> <td rowspan="8">Ground (sensor voltage, connected to M5)</td> <td>⊕</td> <td rowspan="8"></td> </tr> <tr> <td>10</td> <td>I0: Input .1</td> <td>42</td> <td>74</td> <td>⊕</td> </tr> <tr> <td>11</td> <td>I0: Input .2</td> <td>43</td> <td>75</td> <td>⊕</td> </tr> <tr> <td>12</td> <td>I0: Input .3</td> <td>44</td> <td>76</td> <td>⊕</td> </tr> <tr> <td>13</td> <td>I0: Input .4</td> <td>45</td> <td>77</td> <td>⊕</td> </tr> <tr> <td>14</td> <td>I0: Input .5</td> <td>46</td> <td>78</td> <td>⊕</td> </tr> <tr> <td>15</td> <td>I0: Input .6</td> <td>47</td> <td>79</td> <td>⊕</td> </tr> <tr> <td>16</td> <td>I0: Input .7</td> <td>48</td> <td>80</td> <td>⊕</td> </tr> <tr> <td>17</td> <td>I1: Input .0</td> <td>49</td> <td></td> <td>81</td> <td>⊕</td> <td rowspan="7"></td> </tr> <tr> <td>18</td> <td>I1: Input .1</td> <td>50</td> <td></td> <td>82</td> <td>⊕</td> </tr> <tr> <td>19</td> <td>I1: Input .2</td> <td>51</td> <td></td> <td>83</td> <td>⊕</td> </tr> <tr> <td>20</td> <td>I1: Input .3</td> <td>52</td> <td></td> <td>84</td> <td>⊕</td> </tr> <tr> <td>21</td> <td>I1: Input .4</td> <td>53</td> <td></td> <td>85</td> <td>⊕</td> </tr> <tr> <td>22</td> <td>I1: Input .5</td> <td>54</td> <td></td> <td>86</td> <td>⊕</td> </tr> <tr> <td>23</td> <td>I1: Input .6</td> <td>55</td> <td></td> <td>87</td> <td>⊕</td> </tr> <tr> <td>24</td> <td>I1: Input .7</td> <td>56</td> <td></td> <td>88</td> <td>⊕</td> </tr> <tr> <td>25</td> <td>I2: Input .0</td> <td>57</td> <td></td> <td>89</td> <td>⊕</td> <td rowspan="2"></td> </tr> <tr> <td>26</td> <td>I2: Input .1</td> <td>58</td> <td></td> <td>90</td> <td>⊕</td> </tr> </tbody> </table>																Terminal tier 1	Terminal tier 2	Terminal tier 3	Terminal tier 4 ¹	1	Q0: Output .0	33	Voltage supply L1+ for channel group Q0: .0 to .7	65	Ground M1 for channel group Q0: .0 to .7	⊕	PE (internally jump-ered, but not connected to PE screw)	2	Q0: Output .1	34	66	⊕	3	Q0: Output .2	35	67	⊕	4	Q0: Output .3	36	68	⊕	5	Q0: Output .4	37	69	⊕	6	Q0: Output .5	38	70	⊕	7	Q0: Output .6	39	71	⊕	8	Q0: Output .7	40	72	⊕	9	I0: Input .0	41	24 V (sensor voltage, connected to L5+)	73	Ground (sensor voltage, connected to M5)	⊕		10	I0: Input .1	42	74	⊕	11	I0: Input .2	43	75	⊕	12	I0: Input .3	44	76	⊕	13	I0: Input .4	45	77	⊕	14	I0: Input .5	46	78	⊕	15	I0: Input .6	47	79	⊕	16	I0: Input .7	48	80	⊕	17	I1: Input .0	49		81	⊕		18	I1: Input .1	50		82	⊕	19	I1: Input .2	51		83	⊕	20	I1: Input .3	52		84	⊕	21	I1: Input .4	53		85	⊕	22	I1: Input .5	54		86	⊕	23	I1: Input .6	55		87	⊕	24	I1: Input .7	56		88	⊕	25	I2: Input .0	57		89	⊕		26	I2: Input .1	58		90	⊕
Terminal tier 1	Terminal tier 2	Terminal tier 3	Terminal tier 4 ¹																																																																																																																																																																				
1	Q0: Output .0	33	Voltage supply L1+ for channel group Q0: .0 to .7	65	Ground M1 for channel group Q0: .0 to .7	⊕	PE (internally jump-ered, but not connected to PE screw)																																																																																																																																																																
2	Q0: Output .1	34		66		⊕																																																																																																																																																																	
3	Q0: Output .2	35		67		⊕																																																																																																																																																																	
4	Q0: Output .3	36		68		⊕																																																																																																																																																																	
5	Q0: Output .4	37		69		⊕																																																																																																																																																																	
6	Q0: Output .5	38		70		⊕																																																																																																																																																																	
7	Q0: Output .6	39		71		⊕																																																																																																																																																																	
8	Q0: Output .7	40		72		⊕																																																																																																																																																																	
9	I0: Input .0	41	24 V (sensor voltage, connected to L5+)	73	Ground (sensor voltage, connected to M5)	⊕																																																																																																																																																																	
10	I0: Input .1	42		74		⊕																																																																																																																																																																	
11	I0: Input .2	43		75		⊕																																																																																																																																																																	
12	I0: Input .3	44		76		⊕																																																																																																																																																																	
13	I0: Input .4	45		77		⊕																																																																																																																																																																	
14	I0: Input .5	46		78		⊕																																																																																																																																																																	
15	I0: Input .6	47		79		⊕																																																																																																																																																																	
16	I0: Input .7	48		80		⊕																																																																																																																																																																	
17	I1: Input .0	49		81	⊕																																																																																																																																																																		
18	I1: Input .1	50		82	⊕																																																																																																																																																																		
19	I1: Input .2	51		83	⊕																																																																																																																																																																		
20	I1: Input .3	52		84	⊕																																																																																																																																																																		
21	I1: Input .4	53		85	⊕																																																																																																																																																																		
22	I1: Input .5	54		86	⊕																																																																																																																																																																		
23	I1: Input .6	55		87	⊕																																																																																																																																																																		
24	I1: Input .7	56		88	⊕																																																																																																																																																																		
25	I2: Input .0	57		89	⊕																																																																																																																																																																		
26	I2: Input .1	58		90	⊕																																																																																																																																																																		

Table 7-13 Pin Assignment of Terminal Blocks TB2/DC; TB2-4/DC and TB4/DC for ET 200B-24DI/8DO (6ES7 133-0BN01-0XB0) and ET 200B-24DI/8DO 0.2ms (6ES7 133-0BN11-0XB0), continued

Terminal tier 1		Terminal tier 2		Terminal tier 3		Terminal tier 4 ¹	
27	I2: Input .2	59	24 V (sensor voltage, connected to L5+)	91	Ground (sensor voltage, connected to M5)	⊕	PE (internally jumpered, but not connected to PE screw)
28	I2: Input .3	60		92		⊕	
29	I2: Input .4	61		93		⊕	
30	I2: Input .5	62		94		⊕	
31	I2: Input .6	63		95		⊕	
32	I2: Input .7	64		96		⊕	
–		L5+	Voltage supply, internal logic and sensor voltage 24 V	M5	Ground connection, internal logic and sensor voltage	⊕	PE (internally jumpered, but not connected to PE screw)
–		L5+	Voltage supply, internal logic and sensor voltage 24 V	M5	Ground connection, internal logic and sensor voltage	⊕	

¹ TB2-4/DC only; in the TB4M/DC tier 4 is available for additional ground connections (see Section 7.2.7)

Important Note on Wiring

The following notes are important as regards the wiring of the ET 200B-24DI/8DO and ET 200B-24DI/8DO 0.2 ms:

- The terminals for PE on the 4-tier terminal block are not connected to the PE connection of terminal block TB2-4/DC.
- If all actuators are connected by two-wire cables to the TB2/DC, TB4/DC or TB2-4/DC, connect the ground of an actuator and the supply for the reference potential per group by means of a DIN 46231 cable cleat.
- L1+ and L5+ and M1 and M5 are **not** interconnected.
- L5+ and terminals 41 ... 64 are interconnected, as are M5 and terminals 73 ... 96.
- The two L5+ terminals are also interconnected.

Fuse

The 24 V sensor supply is protected by fuse F1 (2.5 A) in the terminal blocks. Nevertheless, make sure that the current does not exceed the specifications in the technical data for the electronics block.

Technical Data

The technical data of electronics blocks ET 200B-24DI/8DO and ET 200B-24DI/8DO 0.2 ms is listed in the tables below.

Technical specifications		Inputs, continued	
Baud rates*	9.6/19.2/93.75/187.5/500/ 1500/3000/6000/ 12000 kbaud	Delay of inputs for 6ES7 133-0BN00-0XB0	3 ms
Bus protocol	PROFIBUS-DP	Delay of inputs for 6ES7 133-0BN10-0XB0	0.2 ms
FREEZE and SYNC capability	Yes*	Connection of 2-wire BERO	Possible
Galvanic isolation to SINEC L2-DP bus	Yes	• Quiescent current	≤ 1.5 mA
Power losses	Max. 5.5 W	Connection of mechanical switches	Possible
Weight (EB and TB)	Approx. 800 g (28 oz.)	Cable length of sensors	
Dimensions (EB and TB: W x H x D)	235 x 130 x 60 mm (9.17 x 5.07 x 2.34 in.)	• Unshielded	Max. 100 m (328 ft.)
Diagnostics functions		Outputs	
Voltage monitoring	Green "RUN" LED	Number of outputs	8
Bus monitoring SINEC L2-DP	Red "BF" LED	Galvanic isolation	Yes
Group diagnostics for short-circuit, load voltage failure	Red "DIA" LED	• In groups of	8
Load voltage monitoring	Green "L1+" LED	Output voltage	
Status of inputs and out- puts	Green LEDs	• For "0" signal	Max. 2 V (idle)
		• For "1" signal	Min. (supply voltage – 3 V)
Supply voltage for sensor supply, load voltage supply and internal logic		Output current	
Supply voltage (L1+,L5+)		• For "0" signal	Max. 1 mA
• Rated value	24 V DC	• For "1" signal	Max. 0.5 A
• Permissible range	18.5 to 30.2 V	Delay of outputs	
• Value for t < 0.5 s	35 V	• From "0" to "1"	Approx. 20 μs
Current consumption from L5+		• From "1" to "0"	Max. 0.5 ms
• Logic	Typ. 85 mA	Switching frequency	
• Sensors	Max. 1 A	• Resistive load	Max. 1000 Hz
I ² t (for the inrush current)	≤ 0.05 A ² s	• Inductive load	Max. 0.5 Hz
		• Lamp load	Max. 8 Hz
Inputs		Short-circuit protection	Yes
Number of inputs	24	Load current	
Galvanic isolation to inter- nal electronic circuits	No	• Total current	Max. 2 A
Input voltage		Lamp load	Max. 5 W
• Rated value	24 V DC	Setting a digital input	Possible
• For "0" signal	– 30 V to 5 V	Limitation of voltage in- duced on current interrup- tion	Typ. (L5+) – 55 V
• For "1" signal	13 V to 30 V	Cable length	Max. 100 m (328 ft.)
Input current for "1" signal	Typ. 4 mA at 24 V Min. 2 mA		

* In operation with the IM 308-B, the maximum baud rate is 1500 kbaud.

7.3.11 Electronics Block ET 200B-16DI-AC (6ES7 131-0HF00-0XB0)

Characteristics The ET 200B-16DI-AC electronics block has the following characteristics:

- 16 inputs, floating in groups of 4
- Input voltage: 120/230 V AC
- Suitable for switches and 2-wire proximity switches acc. to IEC 1131, type 1
- Possible terminal block: TB6/AC

Dimensional Drawing See Figure 7-22 for the precise dimensions.

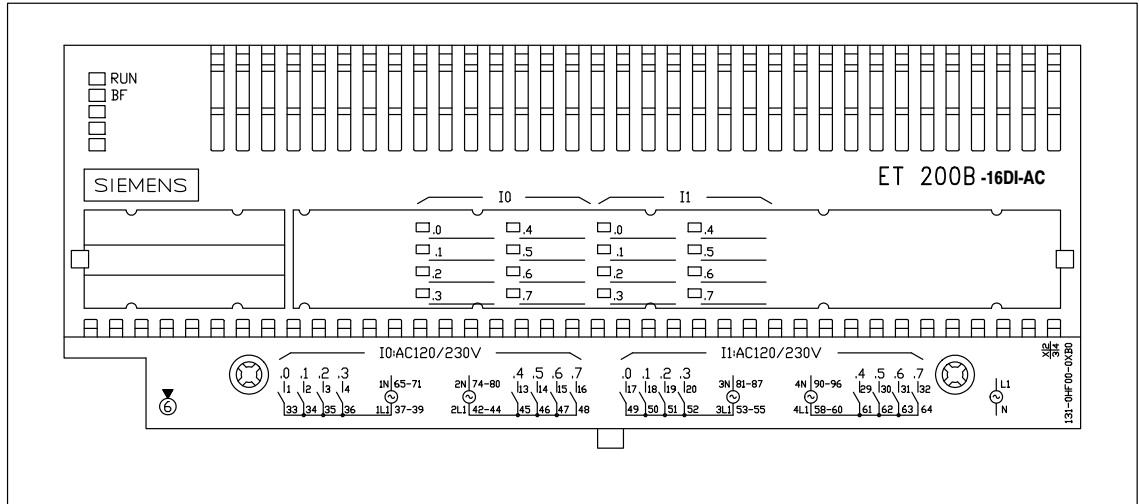

Figure 7-50 Front Elevation: ET 200B-16DI-AC (6ES7 131-0HF00-0XB0)

Block Diagram

Simplified diagram of the potential for the ET 200B-16DI-AC and TB6/AC:

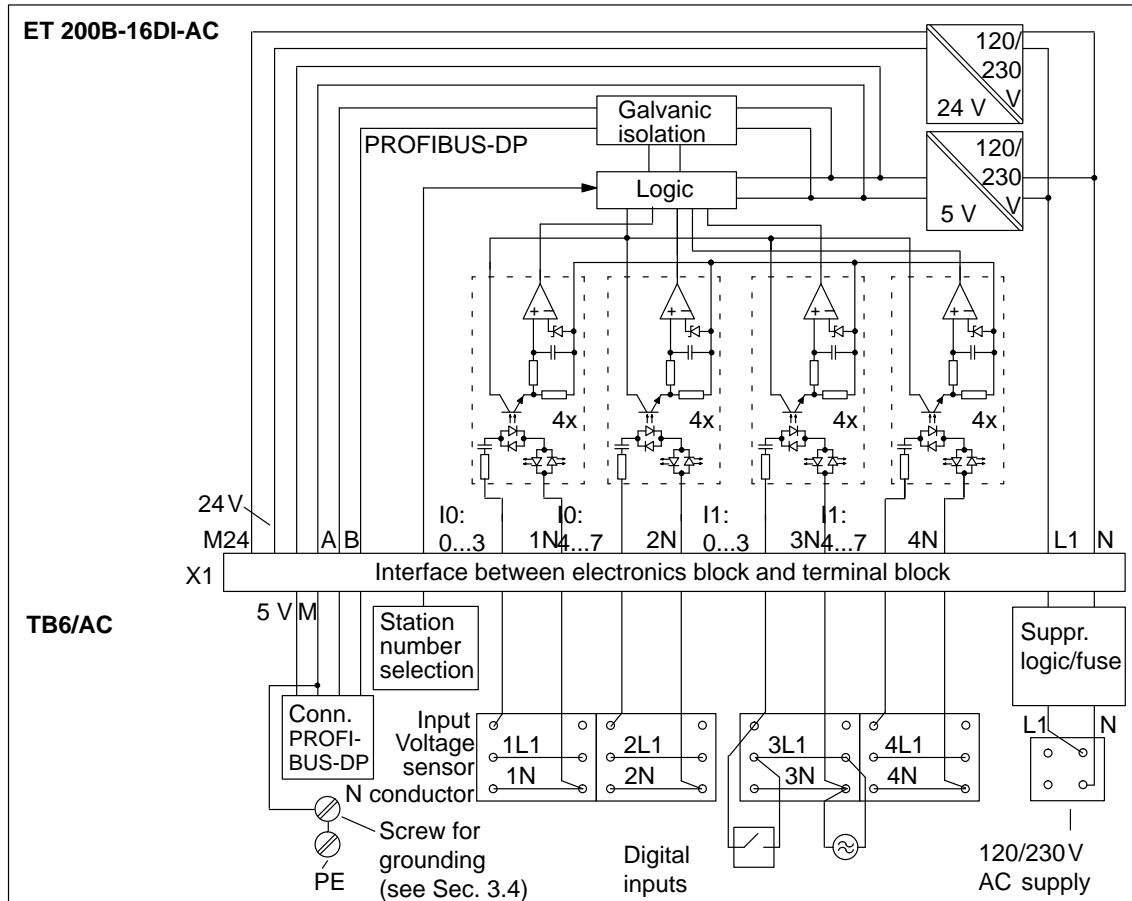

Figure 7-51 Block Diagram: ET 200B-16DI-AC (6ES7 131-0HF00-0XB0) and TB6/AC

Pin Assignment

The table below shows the pin assignment of the terminal blocks for ET 200B-16DI-AC. For the sake of clarity, the table also shows the terminal numbering of the terminal block, taking the TB6/AC by way of example.

Table 7-14 Pin Assignment of Terminal Block TB6/AC for ET 200B-16DI-AC (6ES7 131-0HF00-0XB0)

Terminal numbering TB6/AC																																	
1	2	3	4	5	6	7	8	9	10	11	12	13	14	15	16	17	18	19	20	21	22	23	24	25	26	27	28	29	30	31	32		
33	34	35	36	37	38	39	40	41	42	43	44	45	46	47	48	49	50	51	52	53	54	55	56	57	58	59	60	61	62	63	64	L1	L1
65	66	67	68	69	70	71	72	73	74	75	76	77	78	79	80	81	82	83	84	85	86	87	88	89	90	91	92	93	94	95	96	N	N

Terminal tier 1		Terminal tier 2		Terminal tier 3	
1	I0: Input .0	33	Sensor voltage 1L1 for channel I0: .0 to .3	65	Sensor voltage 1N for channel I0: .0 to .3
2	I0: Input .1	34		66	
3	I0: Input .2	35		67	
4	I0: Input .3	36		68	
5	not used	37		69	
6	not used	38		70	
7	not used	39		71	
8	not used	40	not used	72	not used
9	not used	41	not used	73	not used
10	not used	42	Sensor voltage 2L1 for channel I0: .4 to .7	74	Sensor voltage 2N for channel I0: .4 to .7
11	not used	43		75	
12	not used	44		76	
13	I0: Input .4	45		77	
14	I0: Input .5	46		78	
15	I0: Input .6	47		79	
16	I0: Input .7	48		80	
17	I1: Input .0	49	Sensor voltage 3L1 for channel I1: .0 to .3	81	Sensor voltage 3N for channel I1: .0 to .3
18	I1: Input .1	50		82	
19	I1: Input .2	51		83	
20	I1: Input .3	52		84	
21	not used	53		85	
22	not used	54		86	
23	not used	55		87	
24	not used	56	not used	88	not used
25	not used	57	not used	89	not used
26	not used	58	Sensor voltage 4L1 for channel I1: .4 to .7	90	Sensor voltage 4N for channel I1: .4 to .7

Table 7-14 Pin Assignment of Terminal Block TB6/AC for ET 200B-16DI-AC (6ES7 131-0HF00-0XB0), continued

Terminal tier 1		Terminal tier 2		Terminal tier 3	
27	not used	59	Sensor voltage 4L1 for channel I1: .4 to .7	91	Sensor voltage 4N for channel I1: .4 to .7
28	not used	60		92	
29	I1: Input .4	61		93	
30	I1: Input .5	62		94	
31	I1: Input .6	63		95	
32	I1: Input .7	64		96	
-		L1	Voltage supply, internal logic	N	Voltage supply, internal logic
-		L1	Voltage supply, internal logic	N	Voltage supply, internal logic

Important Note on Wiring

The following notes are important as regards the wiring of the ET 200B-16DI-AC:

- If installed in an 230 V AC system, the following must always be connected to the same outer conductor (same phase):
 - 1L1/1N and 2L1/2N (same phase)
 - 3L1/3N and 4L1/4N (same phase)
- If installed in an 230 V AC system with ambient temperatures in excess of 40 °C only 12 inputs can be used and rated input current must not exceed 240 V AC.

Technical Data

The technical data of electronics block ET 200B-16DI-AC is listed in the tables below.

Technical specifications		Inputs	
Baud rates*	9.6/19.2/93.75/187.5/500/ 1500/3000/6000/ 12000 kbaud	Number of inputs	16
Bus protocol	PROFIBUS-DP	Galvanic isolation	Yes (optocouplers)
Galvanic isolation to SINEC L2-DP	Yes, 500 V DC to logic, 1500 V AC to connection terminals	• In groups of	4
Power losses		Input voltage	
• at 230 V	Typ. 6 W	• Rated value	120/230 V AC
• at 120 V	Typ. 4.5 W	• For "0" signal	0 to 40 V AC
Weight (EB and TB)	811 g (29 oz.)	• For "1" signal	79 to 264 V AC
Dimensions (EB and TB: W x H x D)	235 x 130 x 60 mm (9.17 x 5.07 x 2.34 in.)	Input current for "1" signal	3 to 16 mA
Diagnostics functions		• At 120 V, 60 Hz	Typ. 6.5 mA
Voltage monitoring	Green "RUN" LED	• At 230 V, 50 Hz	Typ. 10.5 mA
Bus monitoring SINEC L2-DP	Red "BF" LED	Type of input acc. to IEC 1131	Type 1
Status of inputs	Green LEDs	Delay of inputs	0 to 25 ms
Supply voltage for internal logic		Connection of 2-wire BERO	No
Supply voltage L1		• Permissible quiescent current	2 mA
• Rated value	120/230 V AC	Connection of mechanical switches	Yes
• Permissible range	85 to 264 V AC	Cable length	Max. 600 m (1968 ft)
• Frequency	47 to 63 Hz		
• Current consumption from L1	Typ. 60 mA		

* In operation with the IM 308-B, the maximum baud rate is 1500 kbaud.

7.3.12 Electronics Block ET 200B-16DO-AC (6ES7 132-0HF00-0XB0)

Characteristics The ET 200B-16DO-AC electronics block has the following characteristics:

- 16 outputs, floating in groups of 4
- Output current: 0.5 A
- Load voltage: 120/230 V AC
- Possible terminal block: TB6/AC

Dimensional Drawing See Figure 7-22 for the precise dimensions.

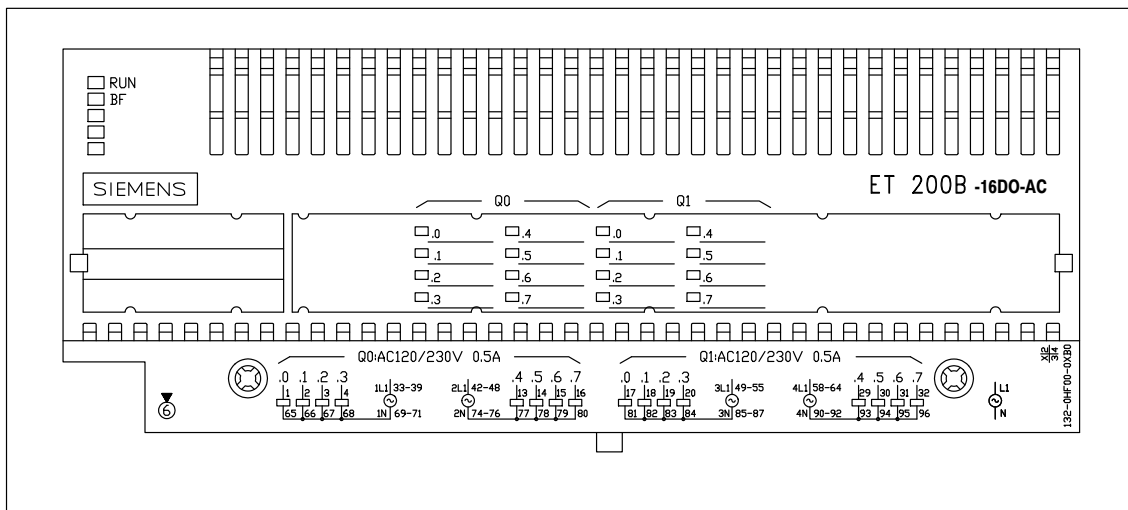

Figure 7-52 Front Elevation: ET 200B-16DO-AC (6ES7 132-0HF00-0XB0)

Block Diagram Simplified diagram of the potential for the ET 200B-16DO-AC and TB6/AC:

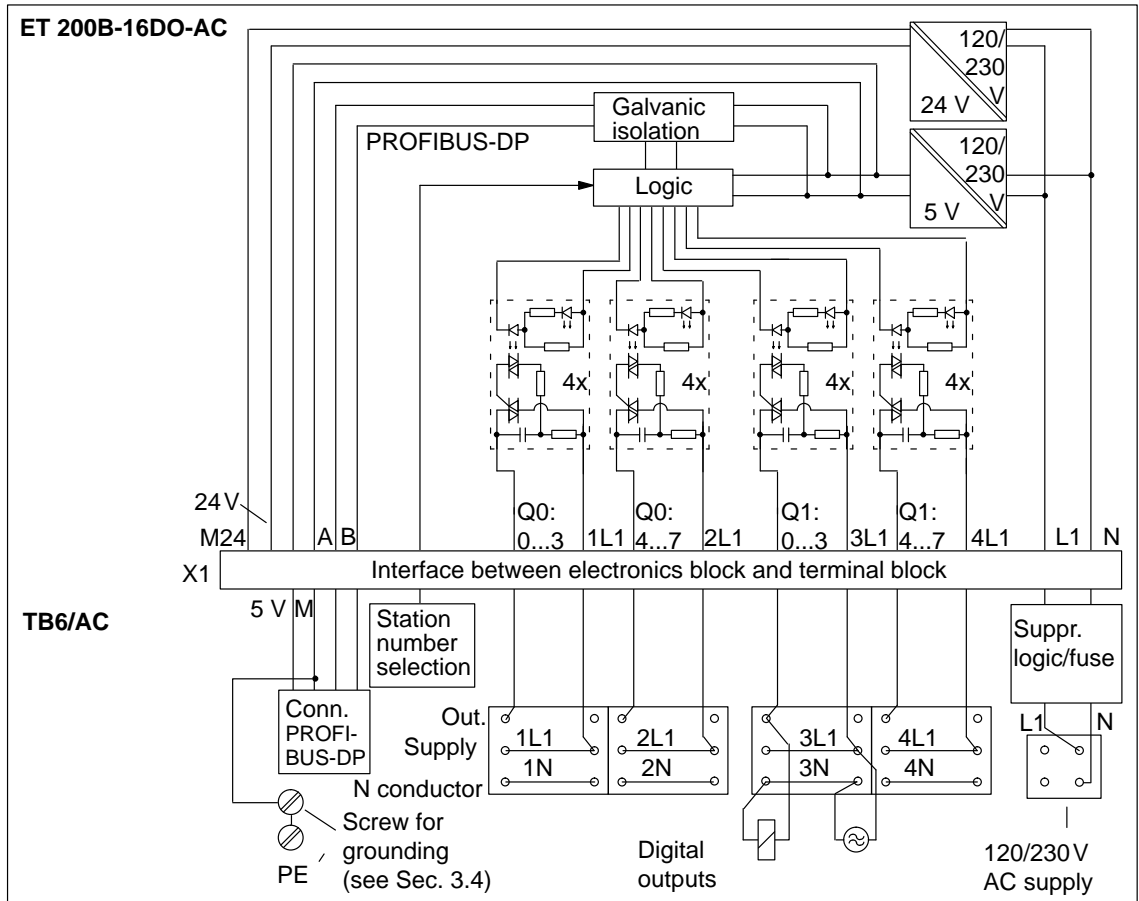

Figure 7-53 Block Diagram: ET 200B-16DO-AC (6ES7 132-0HF00-0XB0) and TB6/AC

Pin Assignment

The table below shows the pin assignment of the terminal blocks for ET 200B-16DO-AC. For the sake of clarity, the table also shows the terminal numbering of the terminal blocks, taking the TB6/AC by way of example.

Table 7-15 Pin Assignment of Terminal Block TB6/AC for ET 200B-16DO-AC (6ES7 132-0HF00-0XB0)

Terminal numbering TB6/AC																																	
1	2	3	4	5	6	7	8	9	10	11	12	13	14	15	16	17	18	19	20	21	22	23	24	25	26	27	28	29	30	31	32		
33	34	35	36	37	38	39	40	41	42	43	44	45	46	47	48	49	50	51	52	53	54	55	56	57	58	59	60	61	62	63	64	L1	L1
65	66	67	68	69	70	71	72	73	74	75	76	77	78	79	80	81	82	83	84	85	86	87	88	89	90	91	92	93	94	95	96	N	N

Terminal tier 1		Terminal tier 2		Terminal tier 3	
1	Q0: Output .0	33	Voltage supply 1L1 for channel Q0: .0 to .3	65	Voltage supply 1N for channel Q0: .0 to .3
2	Q0: Output .1	34		66	
3	Q0: Output .2	35		67	
4	Q0: Output .3	36		68	
5	not used	37		69	
6	not used	38		70	
7	not used	39		71	
8	not used	40	not used	72	not used
9	not used	41	not used	73	not used
10	not used	42	Voltage supply 2L1 for channel Q0: .4 to .7	74	Voltage supply 2N for channel Q0: .4 to .7
11	not used	43		75	
12	not used	44		76	
13	Q0: Output .4	45		77	
14	Q0: Output .5	46		78	
15	Q0: Output .6	47		79	
16	Q0: Output .7	48		80	
17	Q1: Output .0	49	Voltage supply 3L1 for channel Q1: .0 to .3	81	Voltage supply 3N for channel Q1: .0 to .3
18	Q1: Output .1	50		82	
19	Q1: Output .2	51		83	
20	Q1: Output .3	52		84	
21	not used	53		85	
22	not used	54		86	
23	not used	55		87	
24	not used	56	not used	88	not used
25	not used	57	not used	89	not used
26	not used	58	Voltage supply 4L1 for channel Q1: .4 to .7	90	Voltage supply 4N for channel Q1: .4 to .7

Table 7-15 Pin Assignment of Terminal Block TB6/AC for ET 200B-16DO-AC (6ES7 132-0HF00-0XB0), continued

Terminal tier 1		Terminal tier 2		Terminal tier 3	
27	not used	59	Voltage supply 4L1 for channel Q1: .4 to .7	91	Voltage supply 4N for channel Q1: .4 to .7
28	not used	60		92	
29	Q1: Output .4	61		93	
30	Q1: Output .5	62		94	
31	Q1: Output .6	63		95	
32	Q1: Output .7	64		96	
-		L1	Voltage supply, internal logic	N	Voltage supply, internal logic
-		L1	Voltage supply, internal logic	N	Voltage supply, internal logic

Important Note on Wiring

The following notes are important as regards the wiring of the ET 200B-16DO-AC:

- If installed in an AC 230 V system, the following must always be connected to the same outer conductor (same phase):
 - 1L1/1N and 2L1/2N (same phase)
 - 3L1/3N and 4L1/4N (same phase)

Technical Data

The technical data of electronics block ET 200B-16DO-AC is listed in the tables below.

Technical specifications		Outputs	
Baud rates*	9.6/19.2/93.75/187.5/500/ 1500/3000/6000/ 12000 kbaud	Number of outputs	16
Bus protocol	PROFIBUS-DP	Galvanic isolation	Yes (optocouplers)
Galvanic isolation to SI- NEC L2-DP bus	Yes, 500 V DC to logic, 1500 V AC to connection terminals	• In groups of	4
Power losses	Max. 11 W	• Signal voltage	79 to 264 V AC
Weight (EB and TB)	Approx. 805 g (29 oz)	Output voltage	
Dimensions (EB and TB: W x H x D)	235 x 130 x 60 mm (9.17 x 5.07 x 2.34 in.)	• For "1" signal (≥ 50 mA)	Max. L1 – 1.5 V
		• For "1" signal (≤ 50 mA)	Max. L1 – 8.5 V
		Output current	
		• For "0" signal	Max. 1.3 mA
		Delay of outputs	Max. 20 ms
		Short-circuit protection	No
		Switching frequency	
		• Resistive load	10 Hz
		• Inductive load	0.5 Hz
		• Lamp load	1 Hz
		Load current per output in preferred mounting position	
		• 0 °C to 40 °C (32 ° F to 104 ° F)	0.5 A
		• 40 °C to 60 °C (32 ° F to 140 ° F)	0.35 A
		Load current per output in other mounting positions	
		• 0 °C to 40 °C (32 ° F to 104 ° F)	0.35 A
		Lamp load	Max. 25 W
		Size of motor starter	Max. size 3 acc. to NEMA
		Parallel connection of 2 outputs	Possible (though not in order to increase power)
		Setting a digital input	Possible
		Cable length	Max. 600 m (1968 ft)
Diagnostics functions			
Voltage monitoring	Green "RUN" LED		
Bus monitoring SINEC L2-DP	Red "BF" LED		
Group diagnostics for short-circuit, load voltage failure	No		
Load voltage monitoring	No		
Status of outputs	Green LEDs		
Supply voltage for internal logic			
Supply voltage L1			
• Rated value	120/230 V AC		
• Permissible range	85 to 264 V AC		
• Frequency	47 to 63 Hz		
• Current consumption from L1	Typ. 150 mA		

* In operation with the IM 308-B, the maximum baud rate is 1500 kbaud.

7.3.13 Electronics Block ET 200B-16RO-AC (6ES7 132-0HH00-0XB0)

Characteristics The ET 200B-16RO-AC electronics block has the following characteristics:

- 16 relay outputs, floating in groups of 1
- Load voltage: 120 V AC
24 ... 150 V DC
- Output current: 4A for outputs 0.0, 0.7, 1.0 and 1.7
12 A for outputs 0.1 to 0.6 and 1.1 to 1.6
- Suitable for AC/DC solenoid valves, switches, motor starters, small-power motors, motors and lamps.
- Possible terminal block: TB6/AC

Dimensional Drawing See Figure 7-22 for the precise dimensions.

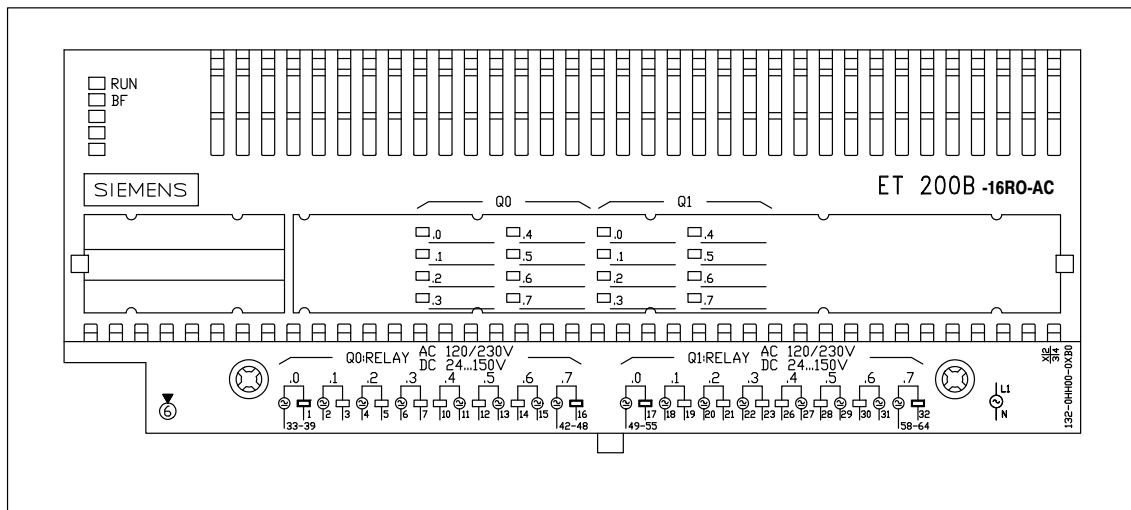

Figure 7-54 Front Elevation: ET 200B-16RO-AC (6ES7 132-0HH00-0XB0)

Block Diagram

Simplified diagram of the potential for the ET 200B-16RO-AC and TB6/DC:

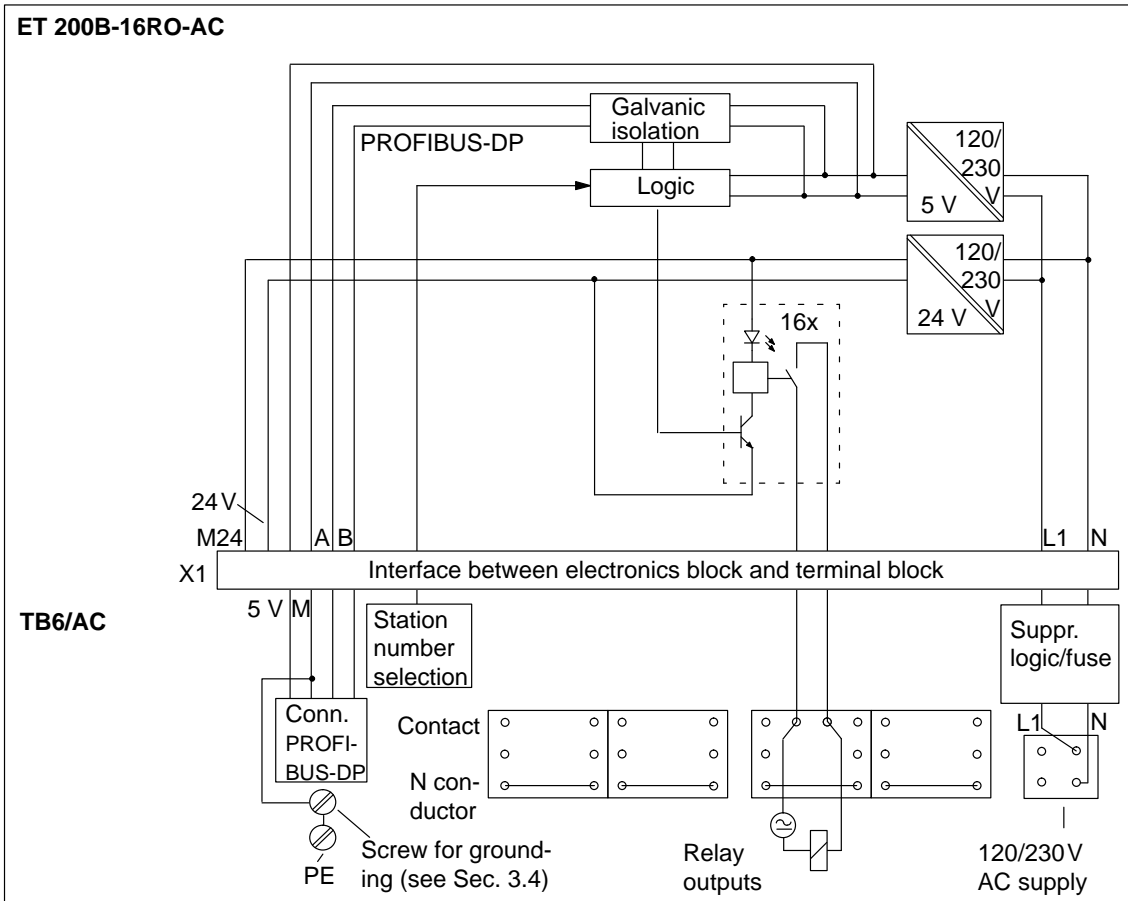

Figure 7-55 Block Diagram: ET 200B-16RO-AC (6ES7 132-0HH00-0XB0) and TB6/AC

Pin Assignment

The table below shows the pin assignment of the terminal blocks for ET 200B-16RO-AC. For the sake of clarity, the table also shows the terminal numbering of the terminal blocks, taking the TB6/AC by way of example.

Table 7-16 Pin Assignment of Terminal Block TB6/AC for ET 200B-16RO-AC (6ES7 132-0HH00-0XB0)

Terminal numbering TB6/AC																																																																																																			
1	2	3	4	5	6	7	8	9	10	11	12	13	14	15	16	17	18	19	20	21	22	23	24	25	26	27	28	29	30	31	32	33	34	35	36	37	38	39	40	41	42	43	44	45	46	47	48	49	50	51	52	53	54	55	56	57	58	59	60	61	62	63	64	L1	L1	65	66	67	68	69	70	71	72	73	74	75	76	77	78	79	80	81	82	83	84	85	86	87	88	89	90	91	92	93	94	95	96	N	N
Terminal tier 1			Terminal tier 2				Terminal tier 3																																																																																												
1	Q0: Connection 0/1	33	Q0: Connection 0/0				65	not used																																																																																											
2	Q0: Connection 1/0	34					66	not used																																																																																											
3	Q0: Connection 1/1	35					67	not used																																																																																											
4	Q0: Connection 2/0	36					68	not used																																																																																											
5	Q0: Connection 2/1	37					69	not used																																																																																											
6	Q0: Connection 3/0	38					70	not used																																																																																											
7	Q0: Connection 3/1	39					71	not used																																																																																											
8	not used	40	not used				71	not used																																																																																											
9	not used	41	not used				73	not used																																																																																											
10	Q0: Connection 4/1	42	Q0: Connection 7/0				74	not used																																																																																											
11	Q0: Connection 4/0	43					75	not used																																																																																											
12	Q0: Connection 5/1	44					76	not used																																																																																											
13	Q0: Connection 5/0	45					77	not used																																																																																											
14	Q0: Connection 6/1	46					78	not used																																																																																											
15	Q0: Connection 6/0	47					79	not used																																																																																											
16	Q0: Connection 7/1	48					80	not used																																																																																											
17	Q1: Connection 0/0	49	Q1: Connection 0/0				81	not used																																																																																											
18	Q1: Connection 1/0	50					82	not used																																																																																											
19	Q1: Connection 1/1	51					83	not used																																																																																											
20	Q1: Connection 2/0	52					84	not used																																																																																											
21	Q1: Connection 2/1	53					85	not used																																																																																											
22	Q1: Connection 3/0	54					86	not used																																																																																											
23	Q1: Connection 3/1	55					87	not used																																																																																											
24	not used	56	not used				88	not used																																																																																											
25	not used	57	not used				89	not used																																																																																											
26	Q1: Connection 4/1	58	Q1: Connection 7/0				90	not used																																																																																											

Table 7-16 Pin Assignment of Terminal Block TB6/AC for ET 200B-16RO-AC
(6ES7 132-0HH00-0XB0), continued

Terminal tier 1		Terminal tier 2		Terminal tier 3	
27	Q1: Connection 4/0	59	Q1: Connection 7/0	91	not used
28	Q1: Connection 5/1	60		92	not used
29	Q1: Connection 5/0	61		93	not used
30	Q1: Connection 6/1	62		94	not used
31	Q1: Connection 6/0	63		95	not used
32	Q1: Connection 7/1	64		96	not used
-		L1	Voltage supply, internal logic	N	Voltage supply, internal logic
-		L1	Voltage supply, internal logic	N	Voltage supply, internal logic

Important Note on Wiring

The following notes are important as regards the wiring of the ET 200B-16RO-AC:

- Protect the module against inductive voltage surges at the relay contacts. Suitable surge protectors are RC elements or varistors connected across the relay contact or across the load. The size and ratings of the protective elements must be dimensioned to suit the size and type of load.
- Voltage surge protectors of this kind extend the service life of the relay contacts.

Technical Data

The technical data of electronics block ET 200B-16RO-AC is listed in the tables below.

Technical specifications		Relay outputs	
Baud rates*	9.6/19.2/93.75/187.5/500/ 1500/3000/6000/ 12000 kbaud	Number of outputs	
Bus protocol	PROFIBUS-DP	• High current	4 (0.0, 0.7, 1.0 and 1.7)
Galvanic isolation to SI- NEC L2-DP bus	Yes, 500 V DC to logic, 1500 V AC to connection terminals	• Low current	12 (0.1 to 0.6, 1.1 to 1.6)
Power losses	20 W	Galvanic isolation	Yes (relays)
Weight (EB and TB)	814 g (29 oz)	• In groups of	1
Dimensions (EB and TB: W x H x D)	235 x 130 x 60 mm (9.17 x 5.09 x 2.34 in.)	Short-circuit protection	No
Diagnostics functions		Relay type	Takamisawa NY 24 W-K
Voltage monitoring	Green "RUN" LED	Output voltage	
Bus monitoring SINEC L2-DP	Red "BF" LED	• Rated value	24 to 150 V DC 120 V AC
Group diagnostics for short-circuit, load voltage failure	No	• Permissible range	0,1 to 150 V DC 79 to 150 V AC
Load voltage monitoring	No	Continuous current I _{th}	Max. 4 A (for high current points) Max. 2 A (for low current points)
Status of outputs	Green LEDs	Switching capacity of con- tacts	
Supply voltage for internal logic		• High current points	
Supply voltage L1		Resistive load	0 to 40 °C 60 °C (32 to 104 ° F) (140° F)
• Rated value	120/230 V AC	24 V DC/120 V AC	4 A 2 A
• Permissible range	85 to 264 V AC	120 V DC	0.2 A 0.2 A
• Frequency	47 to 63 Hz	Inductive load	
• Current consumption from L1	Typ. 210 mA	24 V DC/120 V AC	2 A 2 A
		120 V DC	0.2 A 0.2 A
		• Low current points	
		Resistive and inductive loads	0 to 40 °C 60 °C (32 to 104 ° F) (140° F)
		24 V DC/120 V AC	2 A 1 A
		120 V DC	0.2 A 0.2 A
		Switching cycles of con- tacts acc. to VDE 0660, Part 200	
		• DC-11	> 100 x 10 ⁶
		• AC-15	> 300 x 10 ⁵
		Switching frequency	
		• Resistive load	Max. 10 Hz
		• Inductive load	Max. 2 Hz
		Cable length	Max. 600 m (1968 ft.)
		Setting a digital input	Possible

* In operation with the IM 308-B, the maximum baud rate is 1500 kbaud.

7.3.14 Electronics Block ET 200B-8DI/8RO-AC (6ES7 133-0HH00-0XB0)

- Characteristics** The ET 200B-8DI/8RO-AC electronics block has the following characteristics:
- 8 inputs, floating in groups of 4
 - 8 relay outputs, floating in groups of 1
 - Input voltage: 120/230 V AC
 - Inputs suitable for switches and 2-wire proximity switches acc. to IEC 1131, type 1
 - 8 relay outputs, floating in groups of 1
 - Output load voltage: 120 V AC
24 ... 150 V DC
 - Output current: 4 A for outputs 0.0 and 0.7
2 A for outputs 0.1 to 0.6
 - Outputs suitable for AC/DC solenoid valves, switches, motor starters, small-power motors, motors and lamps.
 - Possible terminal block: TB6/AC

Dimensional Drawing See Figure 7-22 for the precise dimensions.

7

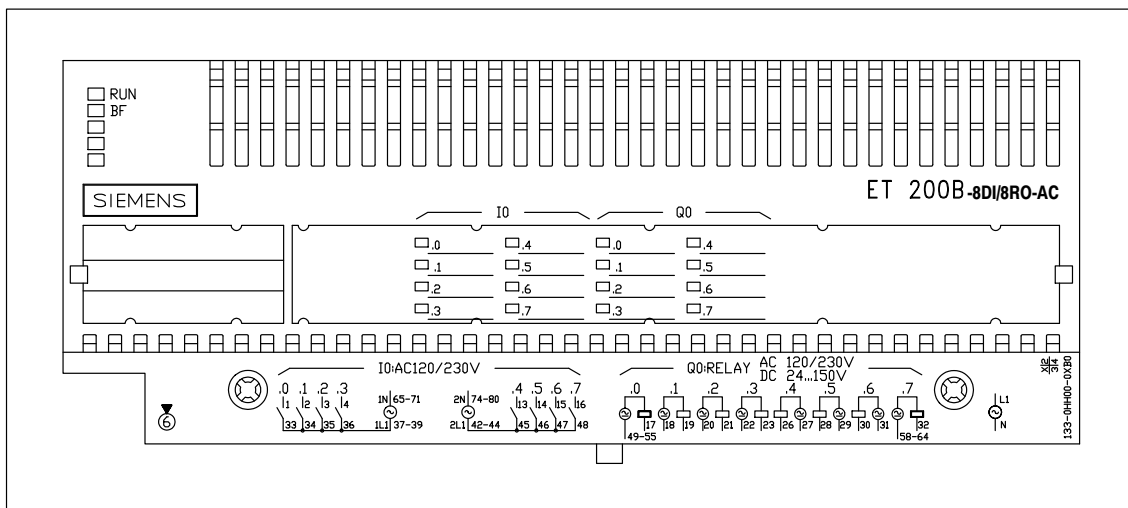

Figure 7-56 Front Elevation: ET 200B-8DI/8RO-AC (6ES7 133-0HH00-0XB0)

Block Diagram Simplified diagram of the potential for the ET 200B-8DI/8RO-AC and TB6/DC:

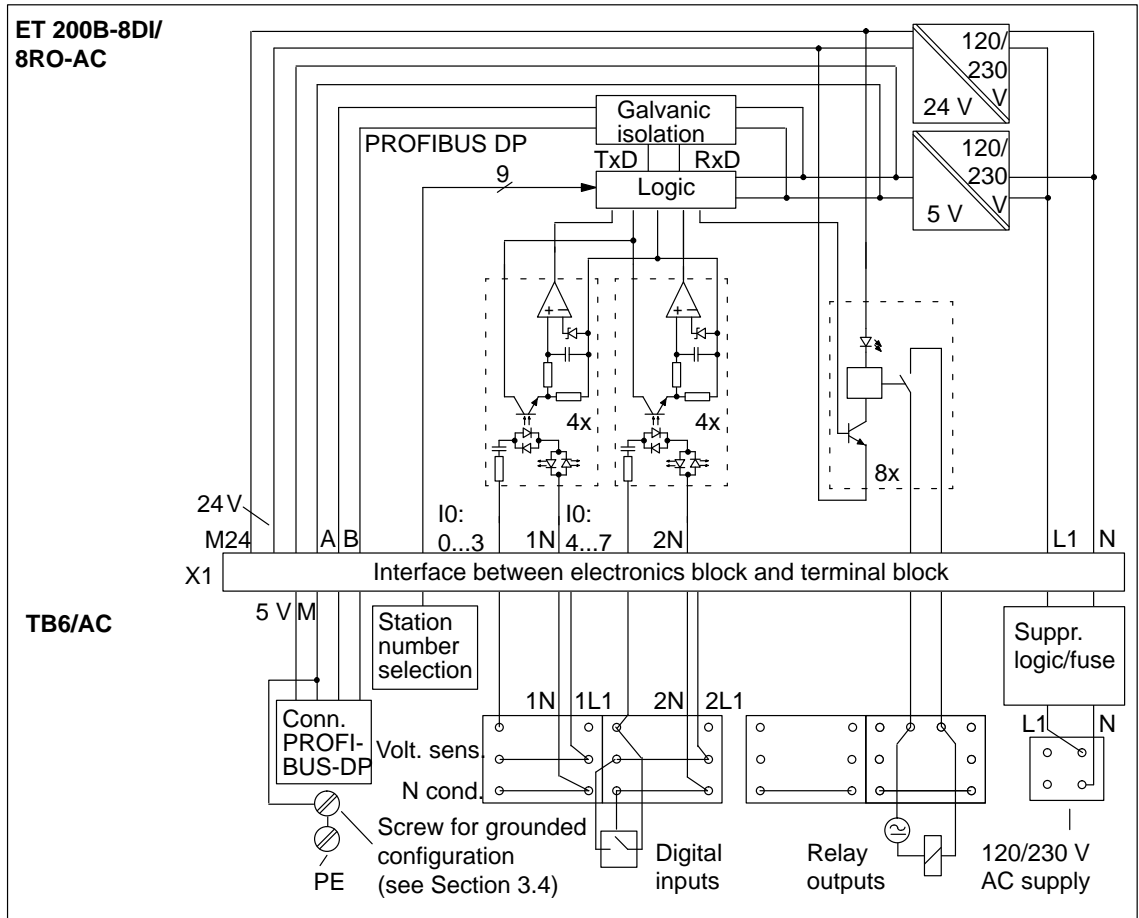

Figure 7-57 Block Diagram: ET 200B-8DI/8RO-AC (6ES7 133-0HH00-0XB0) and TB6/AC

Pin Assignment

The table below shows the pin assignment of the terminal blocks for ET 200B-8DI/8RO-AC. For the sake of clarity, the table also shows the terminal numbering of the terminal blocks, taking the TB6/AC by way of example.

Table 7-17 Pin Assignment of Terminal Block TB6/AC for ET 200B-8DI/8RO-AC (6ES7 133-0HH00-0XB0)

Terminal numbering TB6/AC																																	
1	2	3	4	5	6	7	8	9	10	11	12	13	14	15	16	17	18	19	20	21	22	23	24	25	26	27	28	29	30	31	32		
33	34	35	36	37	38	39	40	41	42	43	44	45	46	47	48	49	50	51	52	53	54	55	56	57	58	59	60	61	62	63	64	L1	L1
65	66	67	68	69	70	71	72	73	74	75	76	77	78	79	80	81	82	83	84	85	86	87	88	89	90	91	92	93	94	95	96	N	N

Terminal tier 1		Terminal tier 2		Terminal tier 3	
1	I0: Input .0	33	Sensor voltage 1L1 for channel I0: .0 to .3	65	Sensor voltage 1N for channel I0: .0 to .3
2	I0: Input .1	34		66	
3	I0: Input .2	35		67	
4	I0: Input .3	36		68	
5	not used	37		69	
6	not used	38		70	
7	not used	39		71	
8	not used	40	not used	72	not used
9	not used	41	not used	73	not used
10	not used	42	Sensor voltage 2L1 for channel I0: .4 to .7	74	Sensor voltage 2N for channel I0: .4 to .7
11	not used	43		75	
12	not used	44		76	
13	I0: Input .4	45		77	
14	I0: Input .5	46		78	
15	I0: Input .6	47		79	
16	I0: Input .7	48		80	
17	Q0: Output 0/1	49	Q0: Output 0/0	81	not used
18	Q0: Output 1/0	50		82	not used
19	Q0: Output 1/1	51		83	not used
20	Q0: Output 2/0	52		84	not used
21	Q0: Output 2/1	53		85	not used
22	Q0: Output 3/0	54		86	not used
23	Q0: Output 3/1	55		87	not used
24	not used	56	not used	88	not used
25	not used	57	not used	89	not used

Table 7-17 Pin Assignment of Terminal Block TB6/AC for ET 200B-8DI/8RO-AC (6ES7 133-0HH00-0XB0), continued

Terminal tier 1		Terminal tier 2		Terminal tier 3	
26	Q0: Output 4/1	58	Q0: Output 7/0	90	not used
27	Q0: Output 4/0	59		91	not used
28	Q0: Output 5/1	60		92	not used
29	Q0: Output 5/0	61		93	not used
30	Q0: Output 6/1	62		94	not used
31	Q0: Output 6/0	63		95	not used
32	Q0: Output 7/1	64		96	not used
-		L1	Voltage supply, internal logic	N	Voltage supply, internal logic
-		L1	Voltage supply, internal logic	N	Voltage supply, internal logic

Important Note on Wiring

The following notes are important as regards the wiring of the ET 200B-8DI/8RO-AC:

- If installed in an 230 V AC system with ambient temperatures in excess of 40 °C only 6 inputs can be used and rated input current must not exceed AC 240 V.
- If installed in an 230 V AC system, the following must always be connected to the same outer conductor (same phase):
 - 1L1/1N and 2L1/2N (same phase)
 - 3L1/3N and 4L1/4N (same phase)
- Protect the module against inductive voltage surges at the relay contacts. Suitable surge protectors are RC elements or varistors connected across the relay contact or across the load. The size and ratings of the protective elements must be dimensioned to suit the size and type of load.
- Voltage surge protectors of this kind extend the service life of the relay contacts.

Technical Data

The technical data of electronics block ET 200B-8DI/8RO-AC is listed in the tables below.

Technical specifications		Inputs	
Baud rates*	9.6/19.2/93.75/187.5/500/ 1500/3000/6000/ 12000 kbaud	Number of inputs	8
Bus protocol	PROFIBUS-DP	Galvanic isolation	Yes (optocouplers)
Galvanic isolation to SI- NEC L2-DP bus	Yes, 500 V DC to logic, 1500 V AC to connection terminals	• In groups of	4
Power losses	13 W	Input voltage	
Weight (EB and TB)	811 g (29 oz)	• Rated value	120/230 V AC
Dimensions (EB and TB: W x H x D)	235 x 130 x 60 mm (9.17 x 5.07 x 2.34 in.)	• For "0" signal	0 to 40 V AC
Diagnostics functions		• For "1" signal	79 to 264 V AC
Voltage monitoring	Green LED "RUN"	Input current for "1" sig- nal	3 to 16 mA
Bus monitoring SINEC L2-DP	Red LED "BF"	• at 120, 60 Hz	Typ. 6.5 mA
Group diagnostics for short-circuit, load voltage failure	No	• at 230 V, 50 Hz	Typ. 10.5 mA
Load voltage monitoring	No	Type of input acc. to IEC 1131	Type 1
Status of outputs	Green LEDs	Delay of inputs	0 to 25 ms
Supply voltage for internal logic		Connection of 2-wire BERO	No
Supply voltage L1		• Permissible quiescent current	2 mA
• Rated value	120/230 V AC,	Connection of mechanical switches	Yes
• Permissible range	85 to 264 V AC	Cable length of sensors	
• Frequency	47 to 63 Hz	Cable length	Max. 600 m (1968 ft.)
• Current consumption from L1	Typ. 165 mA	Relay outputs	
* In operation with the IM 308-B, the maximum baud rate is 1500 kbaud.		Number of outputs	
		• High current	2 (0.0, 0.7)
		• Low current	6 (0.1 to 0.6)
		Galvanic isolation	Yes (relays)
		• In groups of	1
		Short-circuit protection	No
		Relay type	Takamisawa NY 24W-K
		Output voltage	
		• Rated value	24 to 150 V DC 120 V AC
		• Permissible range	0.1 to 150 V DC 79 to 150 V AC
		Continuous current I_{th}	Max. 4 A (for high current points) Max. 2 A (for low current points)

Relay outputs, continued		
Switching capacity of contacts		
• High current points		
Resistive load	0 to 40 °C (32 to 104 ° F)	60 °C (140° F)
24 V DC/ 120/230 V AC	4 A	2 A
120 V DC	0.2 A	0.2 A
Inductive load		
24 V DC/ 120/230 V AC	2A	2A
120 V DC	0.2 A	0.2 A
• Low current points		
Resistive and inductive loads	0 to 40 °C (32 to 104 ° F)	60 °C (140° F)
24 V DC/ 120/230 V AC	2A	1 A
120 V DC	0.2 A	0.2 A
Switching cycles of contacts acc. to VDE 0660, Part 200		
• DC-11	> 100 x 10 ⁶	
• AC-15	> 300 x 10 ⁵	
Switching frequency		
• Resistive load	Max. 10 Hz	
• Inductive load	Max. 2 Hz	
Cable length	Max. 600 m (1968 ft.)	
Setting a digital input	Possible	

Analog Modules

8

Introduction

There are a number of analog modules for connecting measured-value sensors and loads/actuators.

In this Chapter

This chapter contains the technical data for the analog modules.

The technical data for each analog module is accompanied by

- details of the measured-value sensors and loads that can be connected,
- information on analog-value display for operation with SIMATIC S5 and S7,
- a list of permissible address IDs, and
- the parameters of the analog modules.

In Section	you will find	on Page
8.1	Analog modules	8-2
8.2	Terminal block TB8 (6ES7 193-0CD40-0XA0)	8-3
8.3	Terminal block TB8 and bus connector	8-4
8.4	Electronics block ET 200B-4/8AI (6ES7 134-0KH01-0XB0)	8-5
8.5	Electronics block ET 200B-4AI (6ES7 134-0HF01-0XB0)	8-51
8.6	Electronics block ET 200B-4AO (6ES7 135-0HF01-0XB0)	8-76

8.1 Analog Modules

Introduction The tables below give an overview of the ET 200B analog modules.

List of Electronics Blocks The following types of electronics block are available:

Table 8-1 Analog Electronics Blocks of ET 200B

Electronics block	Description
ET 200B-4/8AI	8 analog differential inputs or 8 × thermocouples, 4 × resistance measurement, 4 × resistance thermometer (PT 100, Ni 100) (measuring principle: integrating)
ET 200B-4AI	4 analog differential inputs (measuring principle: successive approximation)
ET 200B-4AO	4 analog outputs

List of Terminal Blocks A single terminal block is available for all analog electronics blocks:

Table 8-2 Analog Terminal Block of ET 200B

Terminal block	Description
TB8	4/8-channel, spring-latch terminals

8.2 Terminal Block TB8 (6ES7 193-0CD40-0XA0)

Dimensional Drawing, TB8 Dimensional drawing: terminal block TB8 (spring-latch terminals)

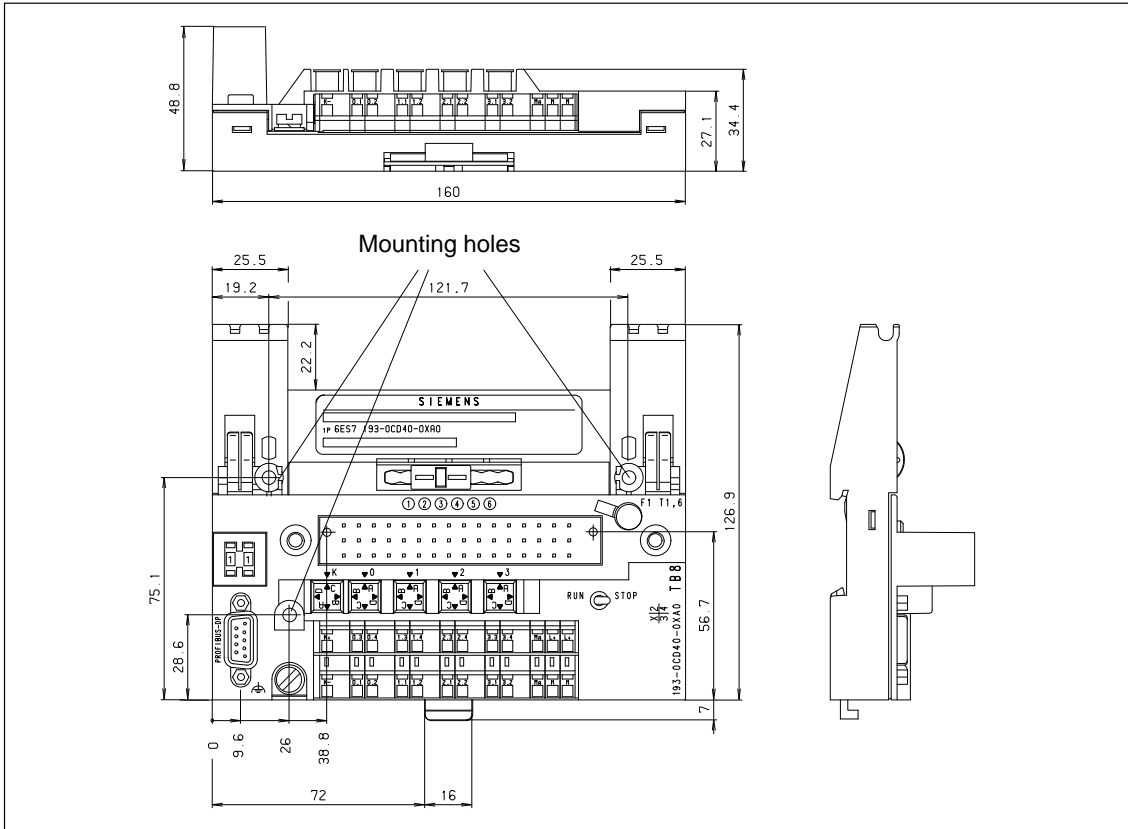

Figure 8-1 Dimensional Drawing: Terminal Block TB8 (Spring-Latch Terminals)

Terminal Numbering Figure 8-2 is an enlargement of the terminal numbering printed on the TB8 (spring-latch terminals).

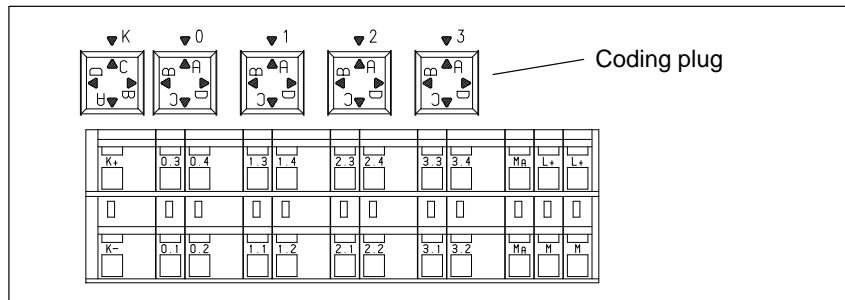

Figure 8-2 Terminal Numbering: Terminal Block TB8 (Spring-Latch Terminals)

8.3 Terminal Block TB8 and Bus Connector

Dimensional Drawing

Figure 8-3 contains the dimensional drawings (side elevation) of the terminal block TB8 with electronics block installed and two different bus connectors.

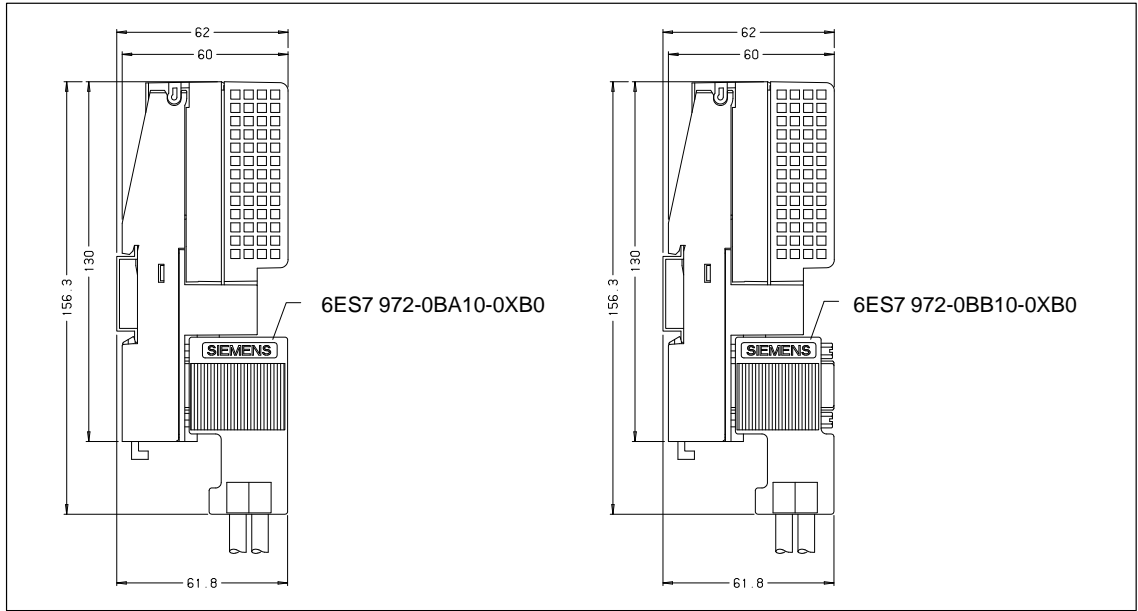

Figure 8-3 Dimensional Drawing: Side Elevation with Bus Connectors (6ES7 972-0BA10-0XA0 and 6ES7 972-0BB10-0XA0)

8.4 Electronics Block ET 200B-4/8AI (6ES7 134-0KH01-0XB0)

Characteristics

The ET 200B-4/8AI electronics block has the following characteristics:

- 8 inputs in 4 channel groups, galvanically isolated from voltage supply to the internal logic
- Transducers supported:
 - Thermocouples: types E, J, K, L, N, T, U
 - Resistance thermometers: Pt 100, Ni 100
 - Resistors: 48 Ω , 150 Ω , 300 Ω , 600 Ω
 - Voltage sensors: ± 80 mV, ± 250 mV, ± 500 mV, ± 1000 mV (2-wire connection)
- Measuring principle: integrating
- Integration times: 2.5 ms, 16.7 ms, 20 ms, 100 ms
- Supply voltage: 24 V DC
- Measured-value range selection via COM ET 200 or STEP 7 or directly via parameterization telegram (see Chapter 4)

Dimensional Drawing

Dimensional drawing of the ET 200B-4/8AI:

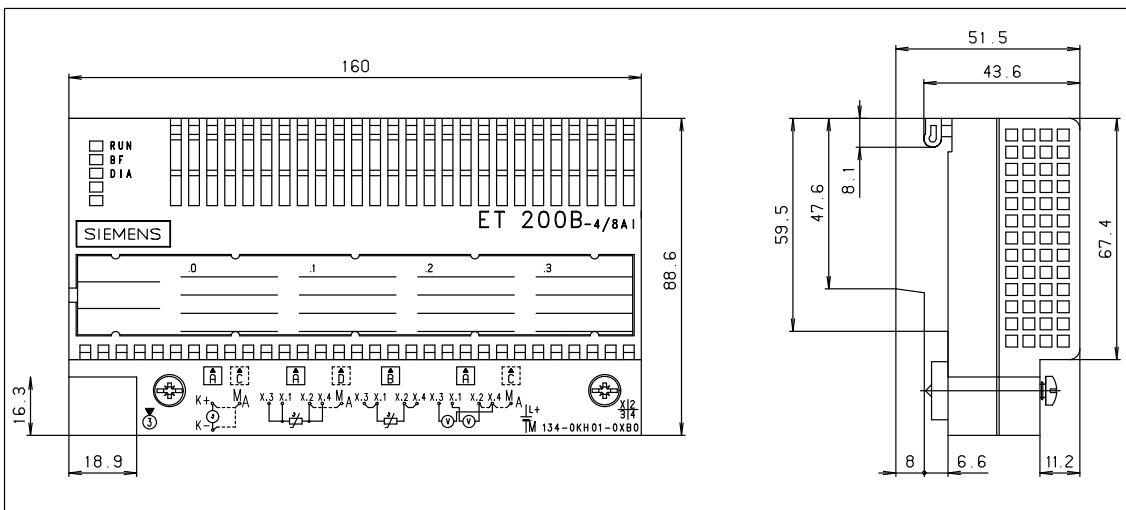

Figure 8-4 Dimensional Drawing: ET 200B-4/8AI (6ES7 134-0KH01-0XB0)

Terminal Numbering

Figure 8-5 is an enlargement of the terminal numbering printed on the ET 200B-4/8AI.

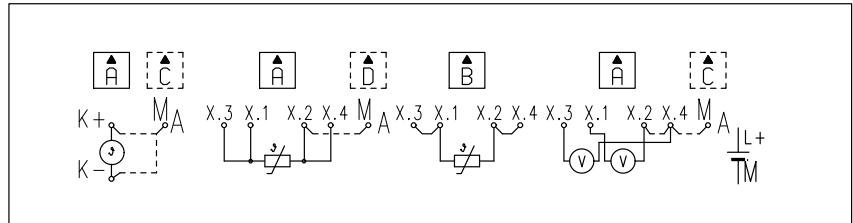

Figure 8-5 Connection Diagram: ET 200B-4/8AI (6ES7 134-0KH01-0XB0)

List of Subsections

The following aspects of the ET 200B-4/8AI are described below:

In Section	you will find	on Page
8.4.1	Connecting transducers	8-7
8.4.2	Configuration options	8-20
8.4.3	Setting the operating mode	8-23
8.4.4	Analog-value representation, operation with SIMATIC S5	8-26
8.4.5	Analog-value representation, operation with SIMATIC S7	8-39
8.4.6	Schematic circuit diagram, terminal assignment and technical data	8-47

8.4.1 Connecting Transducers

Possible Connections

You can connect the following to the ET 200B-4/8AI electronics block:

- Up to 8 thermocouples with compensating box
- Up to 4 resistance thermometers in 2-wire or 4-wire connection
- Up to 4 resistors in 2-wire or 4-wire connection
- Up to 8 voltage sensors (2-wire connection)

Mixed configurations with different types of sensor are possible.

Channel Group

A channel group consists of two channels set with the parameterization software COM ET 200 or STEP 7 (diagnostics enable, measurement type, measuring range, etc.) and with the coding plug on the TB8 (input circuit).

The settings of a channel group apply to all the channels in the group in question.

Input Circuit

There are two ways of measuring analog signals from thermocouples, resistance thermometers, resistors and voltage transducers:

- Floating-ground measurement
- Ground-referenced measurement

You set the input circuit for floating-ground or ground-referenced measurement by means of the coding plugs on the TB8 (one coding plug per channel group)

Floating-Ground Measurement

In the case of floating-ground measurement (differential measurement), each signal line has its own signal reference conductor.

Differential measurement is required in the following cases:

- If the sensors are connected to different potentials and
- If the different signal sources are physically apart.

Note

The maximum permissible common mode voltage (V_{CM}) of the differential inputs to analog ground (M_A) is $\pm 1V$.

The maximum permissible voltage difference between M_A and PE must not exceed 75 V DC/60 V AC.

Avoid ground loops!

Ground-Referenced Measurement

In the case of ground-referenced measurement, all signal reference conductors in the TB8 are connected to a common reference point (analog ground M_A).

To avoid ground loops, galvanically isolated and ungrounded signal sources (thermocouples, Pt 100, voltage sources) are required.

Note

Connect M_A to PE () to enhance noise immunity in the case of ground-referenced measurement.

Connecting Thermocouples with Compensating Boxes

The ET 200B-4/8AI does not have an internal compensating box. The influence of temperature on the reference junction can be countered with a compensating box.

Please note the following rules when connecting a compensating box:

- In a configuration with external compensation you need only one compensating box for all the thermocouples of a single type (E, J, K, L, N, T, U) in a module.

Connect the compensating box to terminals K+ and K- (see for example Figure 8-6).

- In a configuration with external compensation you can connect a maximum of 4 different thermocouples (a different type of thermocouple for each channel group) if you use a separate compensating box for each connection.

In this case the unused K+ and K- terminals must be connected to M_A . (see Figure 8-7)

- In a configuration with external compensation and one compensating box per channel the same thermocouple type must be used per channel group.
- The compensating box requires a floating power supply. The power supply unit of the compensating box must have a grounded braided shield.

Figures 8-6 to 8-8 illustrate the connection options for thermocouples. A maximum of 8 thermocouples can be connected.

Valid Compensating Boxes

We recommend the following compensating boxes for connection to the ET 200B-4/8AI:

- Compensating box type U with current stabilizer.
- Reference junction with built-in power supply unit.

Order Numbers

The order numbers of the compensating boxes and the associated components can be found in the tables below.

Table 8-3 Compensating Box Type U with Current Stabilizer.

Accessories	Weight	Order Number
Type U compensating box Reference temp. 20 °C (68 °F)→ 0 mV 0 °C (32 °F)→ 0 mV	0.22 kg (7.7 oz.) 0.22 kg (7.7 oz.)	C70153-A502-A1 C70153-A502-A5
Insert for type U compensating box (as spare part and for installation in distribution boxes or similar) Reference temp. 20 °C (68 °F)→ 0 mV 0 °C (32 °F)→ 0 mV	0.09 kg (3.15 oz.) 0.09 kg (3.15 oz.)	C70153-A502-B7 C70153-A502-B9
Current stabilizer for feeding a compensating box for thermocouple Fe/Cu Ni, Ni Cr/Ni Reference temp. 20 °C (68 °F)→ 0 mV 0 °C (32 °F)→ 0 mV	0.25 kg (8.75 oz.) 0.25 kg (8.75 oz.)	M55232-A1 M55232-A2

Table 8-4 Reference Junction with Built-in Power Supply Unit

Accessories	Order Number
Reference junction with built-in power supply unit for busbar installation	M72166-□□□□□
Auxiliary energy 220 V AC 110 V AC 24 V AC 24 V DC	B1 B2 B3 B4
Connection to thermocouple Fe-CuNi Type L Fe/Cu Ni Type J Ni Cr/Ni Type K Cu-CuNi Type U Cu/Cu Ni Type T	1 2 3 6 7
Reference temperature 0 °C 20 °C	00 20

On the Following Pages

The following pages contain a connection example for every connection possibility and measuring principle. Please note the following rules.

Rules

Please note the following rules when connecting measured-value sensors to the ET 200B-4/8AI:

- The permissible potential difference at the differential input (x.1 ↔ x.2 or x.3 ↔ x.4, x = 0 to 3) must not exceed ± 1 V.
- The maximum permissible common mode voltage (V_{CM}) between the differential inputs (x.1 ↔ x.2, x.3 ↔ x.4, x = 0 to 3) and analog ground M_A is ± 1 V.
- The maximum permissible isolation voltage between analog ground (M_A) and PE () or between the reference potential of the supply voltage (M) is 75 V DC/60 V AC.
- You must short-circuit the connection terminals of unused voltage inputs and connect them to M_A .

If the coding plug is in the C position, the connection to M_A is not required (already jumpered internally).

- If you connect only one voltage sensor (2-wire connection) to one channel, you must also short-circuit the remaining free differential input of the channel group and connect it to M_A .

If the coding plug is in the C position, the connection to M_A is not required (already jumpered internally).

- If you connect a compensating box, you must short-circuit terminals “K+” and “K-”. For this purpose, set the coding plug to the “C” position.

Note

Please note the explanation of shielding of analog lines in Sections 3.1 and 3.5.

Floating-Ground Measurement

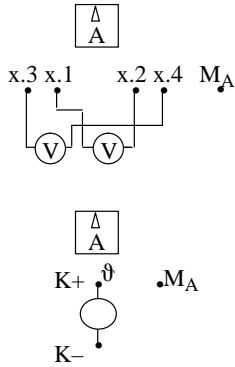

The figure below illustrates the connection of thermocouples of the same type with **one** compensating box **for the entire module** (floating-ground measurement):

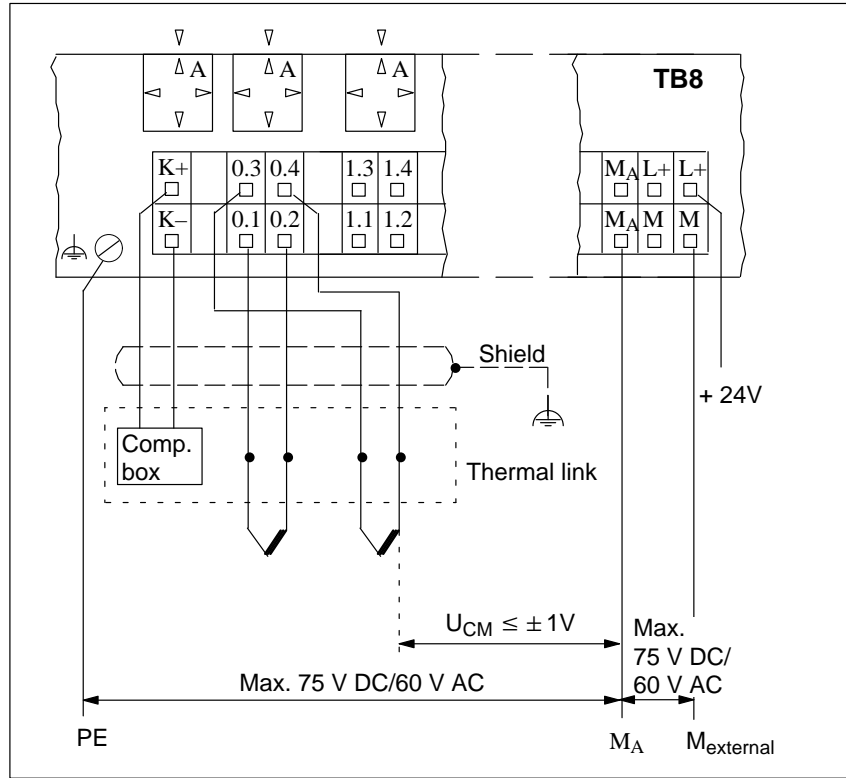
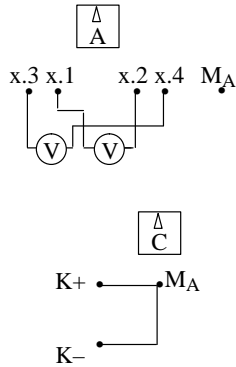

Figure 8-6 Connection of Thermocouples with one Compensating Box (Floating-Ground Measurement)

Note

The maximum permissible common mode voltage ($V_{CM} \leq \pm 1V$) must not be exceeded at any of the differential inputs with reference to M_A .

Floating-Ground Measurement



The figure below illustrates the connection of thermocouples of different types with **one** compensating box **per channel** (floating-ground measurement):

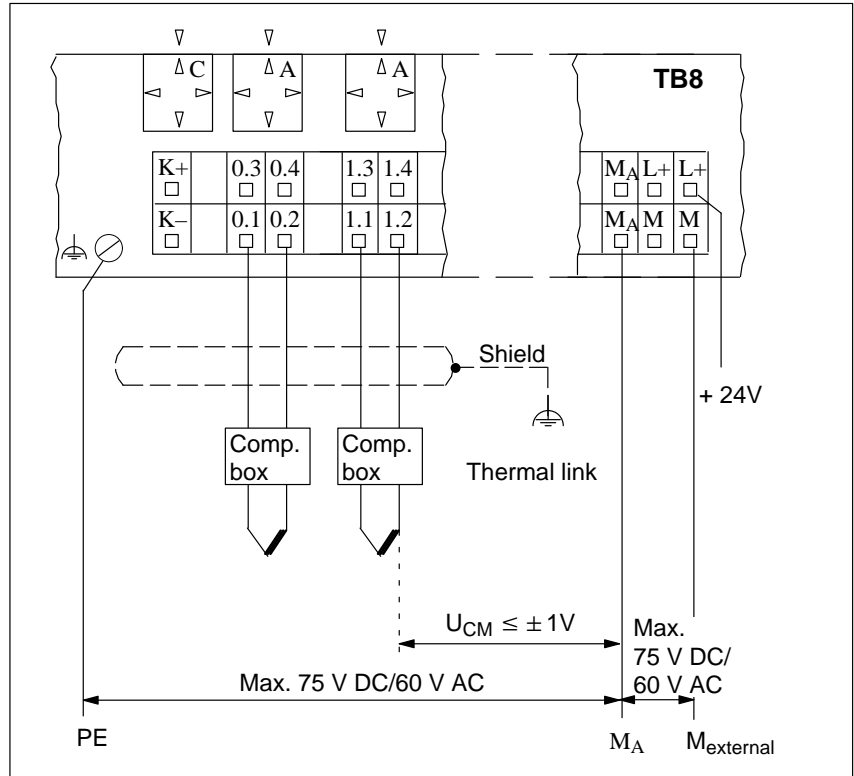

Figure 8-7 Connection of Thermocouples with one Compensating Box per Channel (Floating-Ground Measurement)

Note

The maximum permissible common mode voltage ($V_{CM} \leq \pm 1V$) must not be exceeded at any of the differential inputs with reference to M_A

Ground-Referenced Measurement

The figure below illustrates the connection of thermocouples of the same type with **one** compensating box **for the entire module** (ground-referenced measurement):

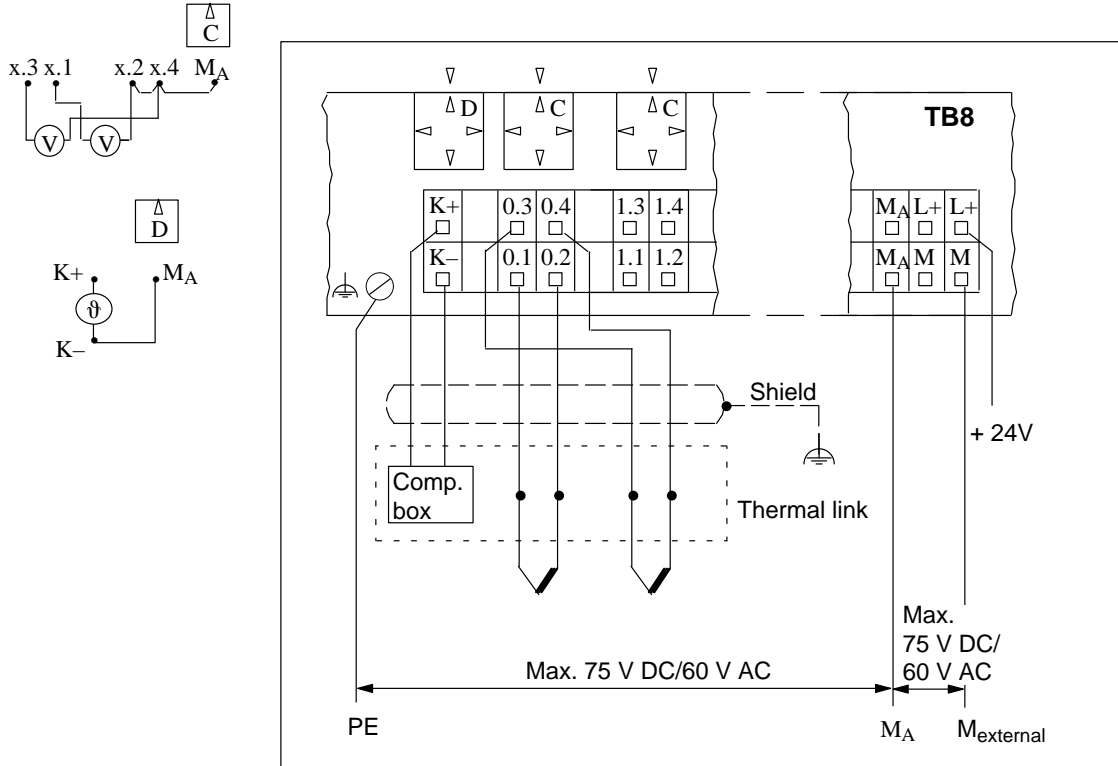

Figure 8-8 Connection of Thermocouples with one Compensating Box (Ground-Referenced Measurement)

Connection of Resistance Thermometers/Resistors (2-Wire Connection)

If resistance thermometers or resistors are connected, resistance can be measured by means of a 2-wire connection.

The resistance thermometer/resistor receives a constant current supply via terminals x.1 and x.2. Voltage drops on the measuring lines may falsify the results. This type of measurement is useful if the measuring lines are short and thick or when the requirements for measuring accuracy are low.

Figures 8-9 and 8-10 show the two methods of connecting resistance thermometers and resistors in a 2-wire connection, taking a Pt 100 by way of example. A maximum of 4 resistance thermometers (Pt 100, Ni 100) or resistors can be connected.

Floating-Ground Measurement

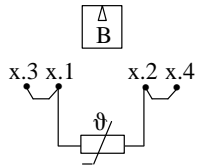

The connection of resistance thermometers (Pt 100) with 2-wire connections (floating-ground measurement) is shown below:

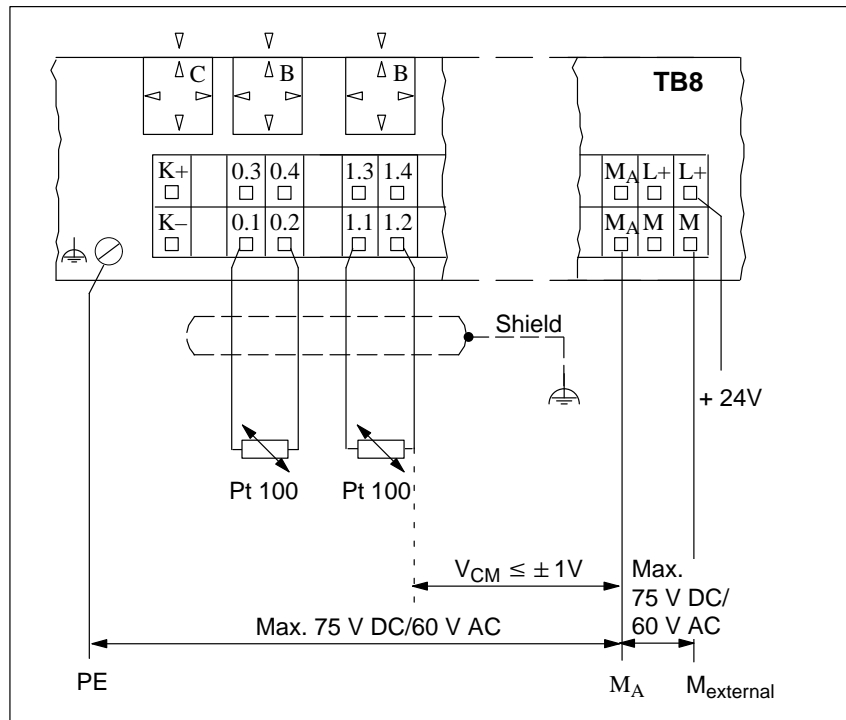
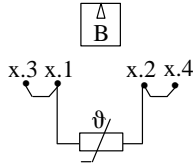

Figure 8-9 Connection of Resistance Thermometers (Pt 100) with 2-Wire Connections (Floating-Ground Measurement)

Note

The maximum permissible common mode voltage ($V_{CM} \leq \pm 1V$) must not be exceeded at any of the differential inputs with reference to M_A .

Ground-Referenced Measurement



In the case of ground-referenced measurement, you must connect terminal x.4 externally with analog ground (M_A).

The connection of resistance thermometers (Pt 100) with 2-wire connections (ground-referenced measurement) is shown below:

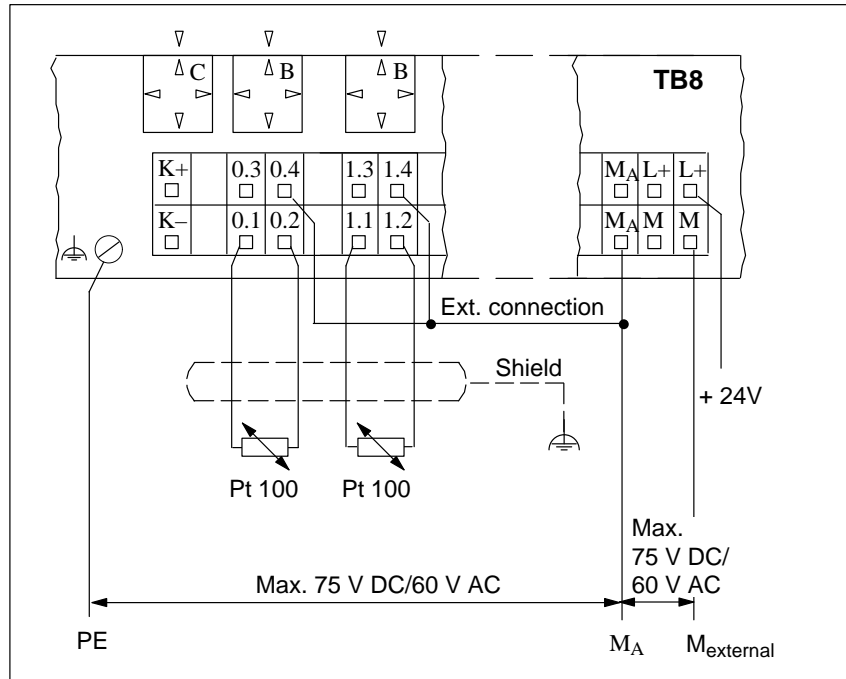

Figure 8-10 Connection of Resistance Thermometers (Pt 100) with 2-Wire Connections (Ground-Referenced Measurement)

Connection of Resistance Thermometers (4-Wire Connection)

If resistance thermometers or resistors are connected, resistance can be measured by means of a 4-wire connection.

A constant current I_c is fed to the resistance thermometer via terminals x.1 and x.2. The voltage generated at the resistance thermometer is measured via x.3/x.4. This means that voltage drops on the “constant current lines” do not corrupt the result of the measurement. The measurement inputs have a high resistance so that only a negligible voltage drop occurs on the measuring lines.

Figures 8-11 and 8-12 show the two methods of connecting resistance thermometers and resistors in a 4-wire connection, taking a Pt 100 by way of example.

Floating-Ground Measurement

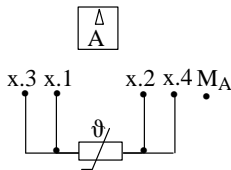

The connection of resistance thermometers (Pt 100) with 4-wire connections (floating-ground measurement) is shown below:

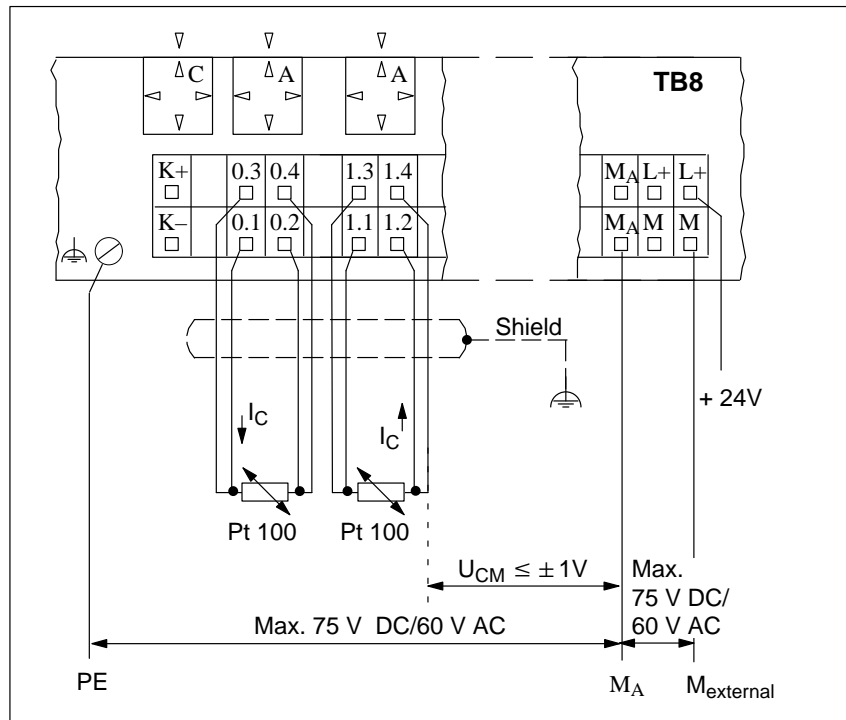

Figure 8-11 Connection of Resistance Thermometers (Pt 100) with 4-Wire Connections (Floating-Ground Measurement)

Note

The maximum permissible common mode voltage ($V_{CM} \leq \pm 1V$) must not be exceeded at any of the differential inputs with reference to M_A .

Ground-Referenced Measurement

The connection of resistance thermometers (Pt 100) with 4-wire connections (ground-referenced measurement) is shown below:

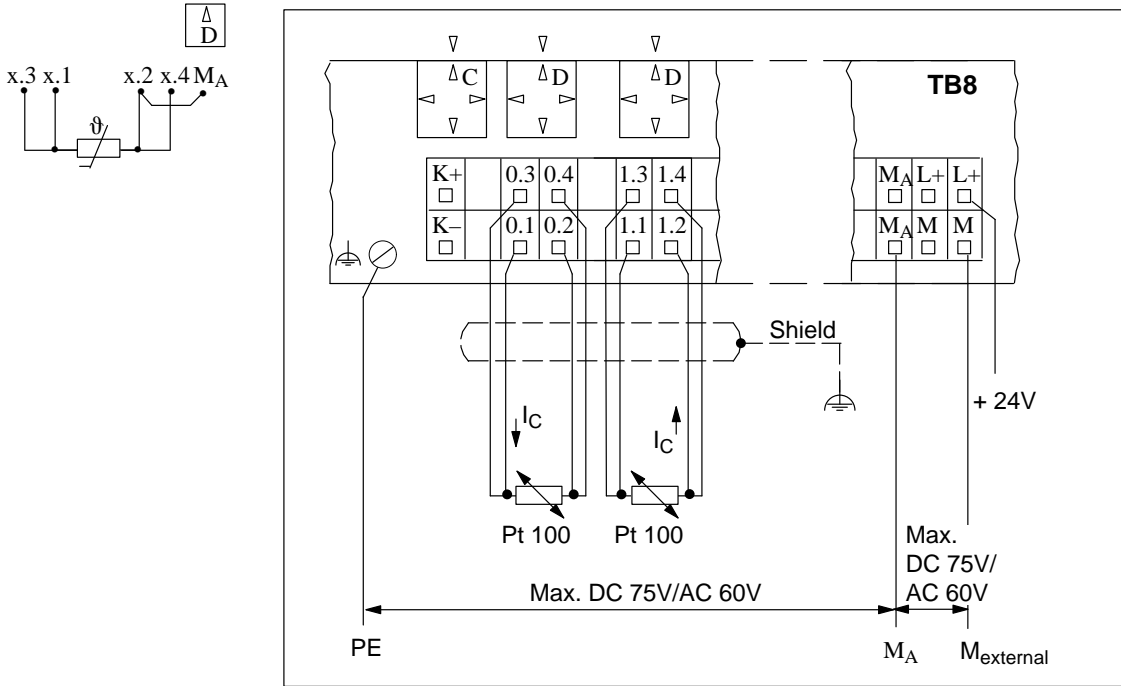

Figure 8-12 Connection of Resistance Thermometers (Pt 100) with 4-Wire Connections (Ground-Referenced Measurement)

Connection of Voltage Sensors

The channels can also be used to connect voltage sensors (± 80 mV, ± 250 mV, ± 500 mV, ± 1000 mV).

Two voltage sensors per channel group can be connected.

Figures 8-13 and 8-14 show the two methods of connecting voltage sensors.

Floating-Ground Measurement

Two-wire connection of voltage sensors (floating-ground measurement) is shown below:

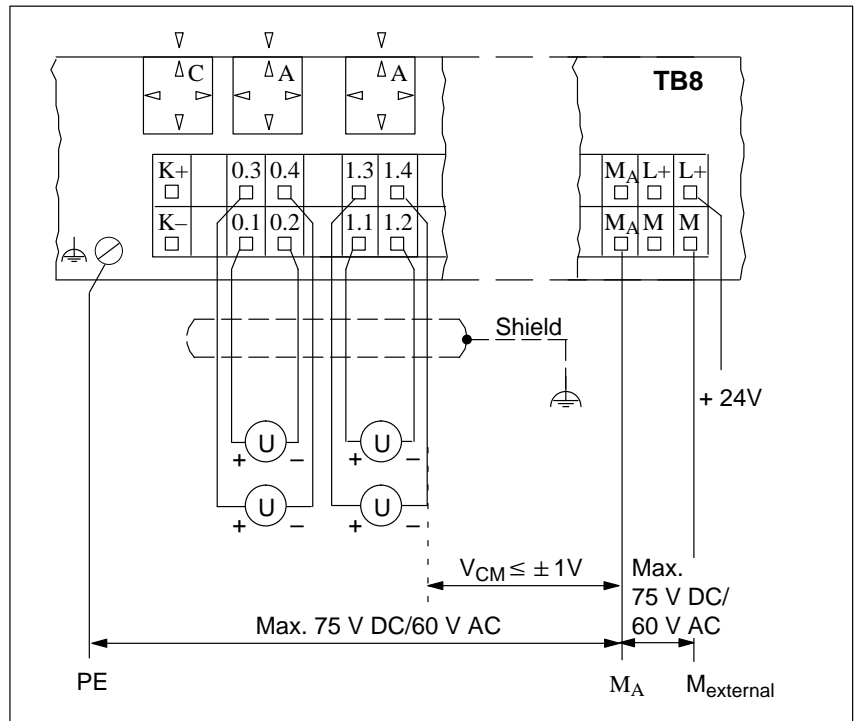
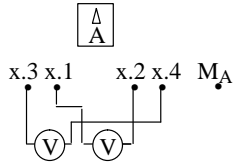

Figure 8-13 2-Wire Connection of Voltage Sensors to ET 200B-4/8AI (Floating-Ground Measurement)

Note

The maximum permissible common mode voltage ($V_{CM} \leq \pm 1V$) must not be exceeded at any of the differential inputs with reference to M_A .

Ground-Referenced Measurement

Two-wire connection of voltage sensors (ground-referenced measurement) is shown below:

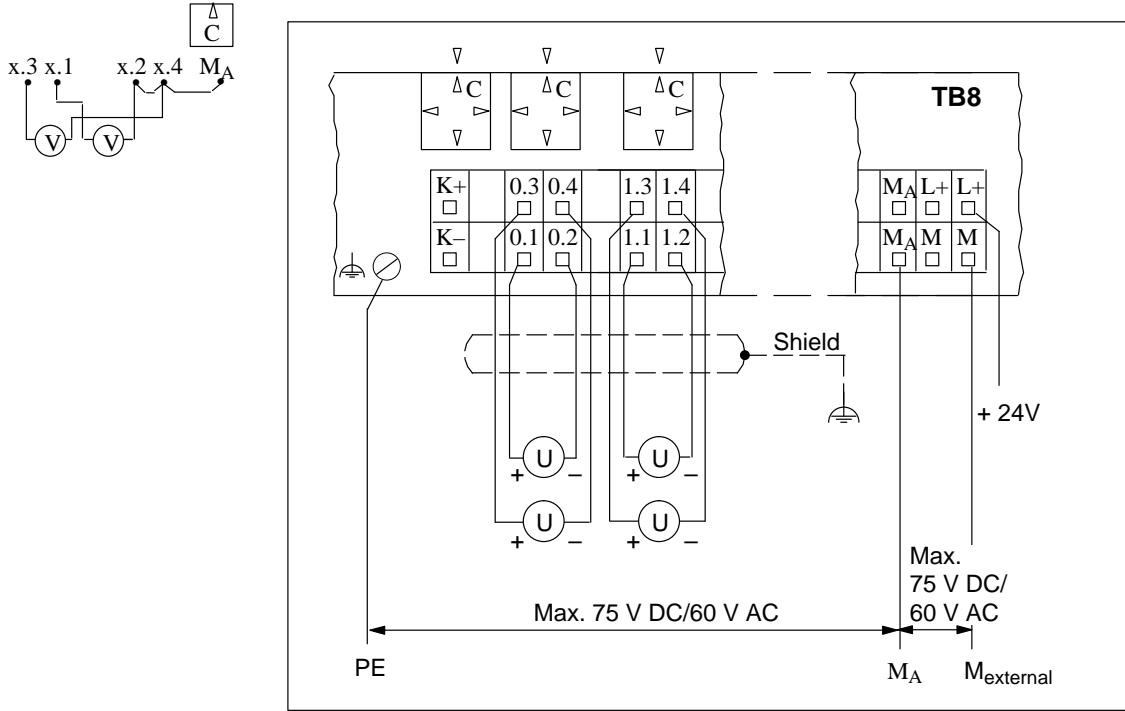

Figure 8-14 2-Wire Connection of Voltage Sensors to ET 200B-4/8AI (Ground-Referenced Measurement)

8.4.2 Configuration Options

Type File

The information in this section applies to the type file **SI801ABE.200**.

The type file contains the possible configurations. The configuration you choose depends on the wiring of the module.

Configuration for Voltage Sensors, Thermocouples

Table 8-5 shows the possible configurations of the ET 200B-4/8AI with COM ET 200 Windows or STEP 7 for connecting voltage sensors and thermocouples.

Table 8-5 lists only the slots for configuring the input areas (slots 4 to 11). Slots 1 to 3 have the default value "004".

Table 8-5 Possible Configurations for the Input Areas of ET 200B-4/8AI, with only Voltage Sensors and Thermocouples Connected

Configuration	Terminals used								Length ¹ (in words)	Meaning
	Channel group 0		Channel group 1		Channel group 2		Channel group 3			
	Channel 0	Channel 1	Channel 2	Channel 3	Channel 4	Channel 5	Channel 6	Channel 7		
	0.1/0.2	0.3/0.4	1.1/1.2	1.3/1.4	2.1/2.2	2.3/2.4	3.0/3.1	3.3/3.4		
8AI	×	×	×	×	×	×	×	×	8	A start address is assigned for the entire module, addresses for 8 words are reserved. (= module addressing)
8 x 1AI	×	×	×	×	×	×	×	×	8	
7 x 1AI	×	×	×	×	×	×	×		7	
6 x 1AI	×	×	×	×	×	×			6	
5 x 1AI	×	×	×	×	×				5	
4 x 1AI	×	×	×	×					4	
3 x 1AI	×	×	×						3	
2 x 1AI	×	×							2	
1 x 1AI	×								1	

¹ Length of user data; × = Connection of measuring lines

Note

If you connect voltage sensors/thermocouples and resistors/thermal resistors to the same module, you have a mixed configuration as shown in Tables 8-5 and 8-6 (see example below).

Configuration for Resistors/Thermal Resistors

Table 8-6 shows the possible configurations of the ET 200B-4/8AI with COM ET 200 Windows or STEP 7 for connecting thermal resistors and for resistance measurement.

Table 8-6 lists only the slots for configuring the input areas (slots 4 to 7). Slots 1 to 3 have the default value "004".

Table 8-6 Possible IDs for Configuring the Input Areas of ET 200B-4/8AI, with only Thermal resistors and Resistors Connected

Config-uration	Terminals used								Length ¹ (in words)	Meaning
	Channel group 0		Channel group 1		Channel group 2		Channel group 3			
	Chan-nel 0	Chan-nel 1	Chan-nel 2	Chan-nel 3	Chan-nel 4	Chan-nel 5	Chan-nel 6	Chan-nel 7		
	0.1/0.2	0.3/0.4	1.1/1.2	1.3/1.4	2.1/2.2	2.3/2.4	3.0/3.1	3.3/3.4		
8AI	o	×	o	×	o	×	o	×	8	A start address is assigned for the entire module, addresses for 8 words are reserved. Input data only in the words for channels 0, 2, 4 and 6. (= module addressing)
5 to 8 x 1AI										This configuration is rejected as errored.
	Channel group 0		Channel group 1		Channel group 2		Channel group 3			
	Channel 0		Channel 1		Channel 2		Channel 3			
	0.1/0.2	0.3/0.4	1.1/1.2	1.3/1.4	2.1/2.2	2.3/2.4	3.0/3.1	3.3/3.4		
4 x 1AI	o	×	o	×	o	×	o	×	4	A separate start address can be assigned for each channel. Addresses are reserved for a maximum of 4 words. (= single-channel addressing)
3 x 1AI	o	×	o	×	o	×			3	
2 x 1AI	o	×	o	×					2	
1 x 1AI	o	×							1	

¹ Length of user data
 × = Connection of measuring lines
 o = Connection of constant-current lines

Example In this example voltage sensors and thermal resistors (Pt 100) are connected.

Table 8-7 Example for Configuring the Input Areas of ET 200B-4/8AI

Config-uration	Terminals used								Length ¹ (in words)	Meaning
	Chan. group 0		Chan. group 1		Chan. group 2		Chan. group 3			
	Chan-nel 0	Chan-nel 1	Channel 2		Chan-nel 3	Chan-nel 4	Chan-nel 5	Chan-nel 6		
0.1/ 0.2	0.3/ 0.4	1.1/ 1.2	1.3/ 1.4	2.1/ 2.2	2.3/ 2.4	3.0/ 3.1	3.3/ 3.4			
	U mea- sure- ment	U mea- sure- ment	Pt 100		U mea- sure- ment	U mea- sure- ment	U mea- sure- ment	U mea- sure- ment		6 voltage sensors and one Pt 100 thermal resistor
7 × 1AI	×	×	o	×	×	×	×	×	7	
	Chan. group 0		Chan. group 1		Chan. group 2		Chan. group 3			
	Channel 0		Ch. 1	Ch. 2	Channel 3		Ch. 4	Ch. 5		
	0.1/ 0.2	0.3/ 0.4	1.1/ 1.2	1.3/ 1.4	2.1/ 2.2	2.3/ 2.4	3.0/ 3.1	3.3/ 3.4		
	Pt 100		U mea- sure- ment	U mea- sure- ment	Pt 100					2 voltage sensors and two Pt 100 thermal resistors
4 × 1AI	o	×	×	×	o	×			4	

¹ Length of user data

× = Connection of measuring lines

o = Connection of constant-current lines

**Notes on Configur-
ing**

Bear the following in mind when configuring the modules:

- If you connect resistance thermometers/resistors, the assignment defined in the configuration and the parameterization must match.
- If you connect 4 resistance thermometers/resistors, the only possible configuration options are 8AI or 4 × 1AI.
- If you use single-channel addressing and configure more channels than is possible for parameterization with resistance thermometers/resistors, an error message is displayed for the module.
- If you connect resistance thermometers/resistors and configure with the 8AI ID, the channels not used by the resistance inputs you configure (channels 1, 3, 5 and 7) are also transmitted to the DP master. In the input area addresses that cannot be used for these channels are assigned.
- If you connect resistance thermometers/resistors and use single-channel addressing, addresses are assigned only for the resistance inputs.
- Diagnostics messages and diagnostics data (slave diagnostics) are returned only for the configured channels.

8.4.3 Setting the Operating Mode

Setting the Operating Mode

You set the operating mode of the ET 200B-4/8AI electronics block

- by means of the coding plugs on the TB8 terminal block and
- by means of the COM ET 200 or STEP7 parameterization software.

Coding Plugs

The coding plugs of the TB8 enable you to set the input circuit of the TB8 for analog value measurement of each individual channel group of the ET 200B-4/8AI in accordance with the measured-value sensor connected and the desired mode of measurement.

The possible settings of the coding plugs are: "A", "B", "C" and "D".

For details of the relationships between the settings of the coding plugs and the mode of measurement and the measured-value sensors, see Section 8.4.1. Section 3.1 describes how to change the settings of the coding plugs.

Channel Group

Some parameters of the ET 200B-4/8AI listed on the following pages apply only to individual channel groups. Table 8-8 lists the assignment of TB8 terminals to channel groups.

Table 8-8 Assignment of Terminals to Channel Groups

Channel Group	Terminals
Channel group 0	Terminals 0.1/0.2
	Terminals 0.3/0.4
Channel group 1	Terminals 1.1/1.2
	Terminals 1.3/1.4
Channel group 2	Terminals 2.1/2.2
	Terminals 2.3/2.4
Channel group 3	Terminals 3.1/3.2
	Terminals 3.3/3.4

Parameters

Table 8-9 shows all the parameters for parameterizing the ET 200B-4/8AI with COM ET 200 Windows or STEP 7.

You can set these parameters for the ET 200B-4/8AI if you use the type file **SI801ABE.200**.

Table 8-9 Parameters for ET 200B-4/8AI (6ES7 134-0KH01-0XB0)

Parameter	Explanation	Value Range
Diagnostics alarm	Diagnostics-alarm enable for module	Disable Enable
End-of-cycle alarm	End-of-cycle alarm enable for module	Disable Enable
Limit-value alarm	Limit-value alarm enable for module	Disable Enable
Diagnostics enable for channel group 0	Diagnostics messages enabled separately for each channel group	Disable Enable
Diagnostics enable for channel group 1		
Diagnostics enable for channel group 2		
Diagnostics enable for channel group 3		
Wire break monitoring enable for channel group 0	Wire break monitoring enabled separately for each channel group: only for resistance thermometers (Pt 100, Ni 100), thermocouples, resistors and voltage sensors ± 80 mV	Disable Enable
Wire break monitoring enable for channel group 1		
Wire break monitoring enable for channel group 2		
Wire break monitoring enable for channel group 3		
Integration time for channel group 0	Enter an optimum integration time for the A/D converter to help suppress noise voltage.	2.5 ms 16.7 ms 20 ms 100 ms
Integration time for channel group 1		
Integration time for channel group 2		
Integration time for channel group 3		

Table 8-9 Parameters for ET 200B-4/8AI (6ES7 134-0KH01-0XB0), continued

Parameter	Explanation	Value Range
Measurement type and range for channel group 0	You can set the measurement type and range separately for each channel group For voltage measurement: For resistance thermometer with linearization: For thermocouple with external reference junction: For resistance measurement:	Channel not activated
Measurement type and range for channel group 1		$\pm 1\text{ V}$ $\pm 0.5\text{ V}$ $\pm 0.25\text{ V}$ $\pm 80\text{ mV}$
Measurement type and range for channel group 2		Pt 100 standard range Ni 100 standard range
Measurement type and range for channel group 3		Type N with linearization Type E with linearization Type J with linearization Type L with linearization Type T with linearization Type K with linearization Type U with linearization
Representation of measured values	Sets representation of the measured values for module	SIMATIC S5 SIMATIC S7
Measured value representation: S5	Sets data format for analog value representation, SIMATIC S5	Complement of twos Amount with sign
Upper limit value for channel 0	Upper and lower limit values for each channel	0 - 32768 ... 32767
Lower limit value for channel 0		0 - 32768 ... 32767
Upper limit value for channel 2 (channel 1*)		0 - 32768 ... 32767
Lower limit value for channel 2 (channel 1*)		0 - 32768 ... 32767

■ : Default

- * For the ET 200B-4/8AI, only the combination of single channel addressing **and** parameterization of channel group 0 for resistance measurement (Pt 100, Ni 100, R) requires parameterization of the "Upper/lower limit values" for channel 1. In all other cases (i.e. module addressing and single channel addressing **and** parameterization of channel group 0 for other than resistance measurement (Pt 100, Ni 100, R), you parameterize "Upper/lower limit values" for channel 2.

8.4.4 Analog Value Representation, Operation with SIMATIC S5

Analog Value Representation, SIMATIC S7

If you operate the ET 200B-4/8AI with SIMATIC S5, you can utilize the analog value representation of SIMATIC S7 (higher measured-value resolution: max. 14 bits + sign). See Section 8.4.5 for the measured-value tables for analog value representation in SIMATIC S7.

Analog Value Representation, SIMATIC S5

Analog values can be represented in two data formats with the ET 200B-4/8AI for SIMATIC S5:

- 12-bit complement of twos representation (range: -2048 to +2047 units)
- 11-bit amount and 1-bit sign (range: -2048 to +2047 units)

The Table below shows the analog value representation of the ET 200B-4AI:

Table 8-10 Representation of an Analog Input Value as a Bit Pattern (6ES7 134-0KH01-0XB0)

	High Byte								Low Byte							
Bit number	15	14	13	12	11	10	9	8	7	6	5	4	3	2	1	0
Analog value representation	SI	2 ¹¹	2 ¹⁰	2 ⁹	2 ⁸	2 ⁷	2 ⁶	2 ⁵	2 ⁴	2 ³	2 ²	2 ¹	2 ⁰	X	F	s

Bits 0 to 2 and bit 15 have no significance for the amount of the measured value. See Table 8-11 for a detailed description of these bits.

Supplementary Bits

Bits 0 to 2 and bit 15 have the following meaning in the bit pattern of the analog input value:

Table 8-11 Description of the Bits (6ES7 134-0KH01-0XB0)

Bit	Meaning	Signal Status	Meaning of the Signal Status
OV	Overflow bit	1	Overrange ¹
F	Fault bit	1	Wire break; the measured value read in is not valid ²
SI	Sign	0	“+” sign
		1	“-” sign
X	Irrelevant	–	–

¹ In the event of an overflow at one measuring point, the overflow bits of the other channels remain unaffected; this means that the values of the other channels are correct and can be evaluated.

² When the ET 200B-4/8AI signals a wire break (fault bit F = 1), the overflow bit OV is also set.

Voltage Measuring Ranges The two tables below show the assignments of analog to digitized measured values for the measuring ranges: ± 80 mV, ± 250 mV, ± 500 mV and ± 1000 mV.

Table 8-12 Representation of Digitized Measured Values of the ET 200B-4/8AI (6ES7 134-0KH01-0XB0; Measuring Ranges: ± 80 mV, ± 250 mV, ± 500 mV and ± 1000 mV; Complement of Twos)

Units	Measured Value in mV				Digitized Measured Value															X	F	O	V	Range
	± 80 mV	± 250 mV	± 500 mV	± 1000 mV	15	14	13	12	11	10	9	8	7	6	5	4	3	2	1					
> 2409	94.10	294.07	588.13	1176.26	0	1	0	0	1	0	1	1	0	1	0	0	1	0	0	1	Overflow			
2408	94.06	293.95	587.89	1175.78	0	1	0	0	1	0	1	1	0	1	0	0	0	0	0	0	Overrange			
:	:	:	:	:	:																			
2049	80.04	250.12	500.24	1000.48	0	1	0	0	0	0	0	0	0	0	0	0	1	0	0	0				
2048	80.00	250.0	500.0	1000.0	0	1	0	0	0	0	0	0	0	0	0	0	0	0	0	0	Nominal range			
1024	40.00	125.00	250.00	500.00	0	0	1	0	0	0	0	0	0	0	0	0	0	0	0	0				
1	0.039	0.12	0.24	0.48	0	0	0	0	0	0	0	0	0	0	0	1	0	0	0					
0	0.00	0.00	0.00	0.00	0	0	0	0	0	0	0	0	0	0	0	0	0	0	0	0				
-1	-0.039	-0.12	-0.24	-0.48	1	1	1	1	1	1	1	1	1	1	1	1	1	0	0	0				
-1024	-40.00	-125.00	-250.00	-500.00	1	1	1	0	0	0	0	0	0	0	0	0	0	0	0	0				
-2048	-80.00	-250.0	-500.0	-1000.0	1	1	0	0	0	0	0	0	0	0	0	0	0	0	0	0				
-2049	-80.04	-250.12	-500.24	-1000.48	1	0	1	1	1	1	1	1	1	1	1	1	1	0	0	0	Overrange			
:	:	:	:	:	:																			
-2408	-94.06	-293.95	587.89	-1175.78	1	0	1	1	0	1	0	0	1	1	0	0	0	0	0	0				
< -2409	-94.10	-294.07	-588.13	-1176.26	1	0	1	1	0	1	0	0	1	0	1	1	1	0	0	1	Overflow			

Table 8-13 Representation of Digitized Measured Values of the ET 200B-4/8AI (6ES7 134-0KH01-0XB0; Measuring Ranges: ± 80 mV, ± 250 mV, ± 500 mV and ± 1000 mV; **Amount and Sign**)

Units	Measured Value in mV				SI	Digitized Measured Value										X	F	OV	Range		
	± 80 mV	± 250 mV	± 500 mV	± 1000 mV		15	14	13	12	11	10	9	8	7	6					5	4
> 2409	94.10	294.07	588.13	1176.26	0	1	0	0	1	0	1	1	0	1	0	0	1	0	0	1	Overflow
2408	94.06	293.95	587.89	1175.78	0	1	0	0	1	0	1	1	0	1	0	0	0	0	0	0	Over-range
:	:	:	:	:								:									
2049	80.04	250.12	500.24	1000.48	0	1	0	0	0	0	0	0	0	0	0	0	0	1	0	0	
2048	80.00	250.0	500.0	1000.0	0	1	0	0	0	0	0	0	0	0	0	0	0	0	0	0	Nominal range
1024	40.00	125.00	250.00	500.00	0	0	1	0	0	0	0	0	0	0	0	0	0	0	0	0	
1	0.039	0.12	0.24	0.48	0	0	0	0	0	0	0	0	0	0	0	0	0	1	0	0	
0	0.00	0.00	0.00	0.00	0	0	0	0	0	0	0	0	0	0	0	0	0	0	0	0	
-1	-0.039	-0.12	-0.24	-0.48	1	0	0	0	0	0	0	0	0	0	0	0	0	1	0	0	
-1024	-40.00	-125.00	-250.00	-500.00	1	0	1	0	0	0	0	0	0	0	0	0	0	0	0	0	
-2048	-80.00	-250.0	-500.0	-1000.0	1	1	0	0	0	0	0	0	0	0	0	0	0	0	0	0	
-2049	-80.04	-250.12	-500.24	-1000.48	1	1	0	0	0	0	0	0	0	0	0	0	1	0	0	0	Over-range
:	:	:	:	:								:									
-2408	-94.06	-293.95	587.89	-1175.78	1	1	0	0	1	0	1	1	0	1	0	0	0	0	0	0	
< -2409	-94.10	-294.07	-588.13	-1176.26	1	1	0	0	1	0	1	1	0	1	0	0	1	0	0	1	Overflow

Note

Bit 15 of the digitized measured value indicates the sign.

The following applies: SI = 0 \rightarrow positive value; SI = 1 \rightarrow negative value.

Measuring Ranges: Resistance Measurement

The table below shows the assignments of analog to digitized measured values for the resistance measuring ranges: 48 Ω, 150 Ω, 300 Ω and 600 Ω.

Table 8-14 Representation of Digitized Measured Values of the ET 200B-4/8AI for Resistance Measurement (Complement of Twos)

Units	Resistance in Ω				Digitized Measured Value													X	F	OV	Range
	48	150	300	600	15	14	13	12	11	10	9	8	7	6	5	4	3				
≥ 2409	56.46	176.44	352.88	705.76	0	1	0	0	1	0	1	1	0	1	0	0	1	0	0	1	Overflow
2408	56.44	176.37	352.73	705.47	0	1	0	0	1	0	1	1	0	1	0	0	0	0	0	0	Over-range
:	:	:	:	:	:																
2049	48.02	150.07	300.14	600.29	0	1	0	0	0	0	0	0	0	0	0	0	1	0	0	0	
2048	48	150	300	600	0	1	0	0	0	0	0	0	0	0	0	0	0	0	0	0	Nominal range
1536	36	112.5	225	450	0	0	1	1	0	0	0	0	0	0	0	0	0	0	0	0	
1024	24	75	150	300	0	0	1	0	0	0	0	0	0	0	0	0	0	0	0	0	
512	12	37.5	75	150	0	0	0	1	0	0	0	0	0	0	0	0	0	0	0	0	
1	0.023	0.072	0.144	0.288	0	0	0	0	0	0	0	0	0	0	0	0	1	0	0	0	
0					0	0	0	0	0	0	0	0	0	0	0	0	0	0	0	1	Overflow
:	(Negative values physically impossible)				:																
X					X	X	X	X	X	X	X	X	X	X	X	X	X	0	1	0	Wire break

**Measuring Range,
Pt 100 Resistance
Thermometers**

The table below shows the assignments of analog to digitized measured values for resistance thermometers (Pt 100):

Table 8-15 Representation of Digitized Measured Values of the ET 200B-4/8AI for Resistance Thermometers (Complement of Twos)

Units	Resistance in Ω	Temperature in $^{\circ}\text{C}$	Digitized Measured Value											X	F	OV	Range		
			15	14	13	12	11	10	9	8	7	6	5					4	3
> 1766	> 400	> 883	0	0	1	1	0	1	1	1	0	0	1	1	0	0	0	1	Overflow
1766		883	0	0	1	1	0	1	1	1	0	0	1	1	0	0	0	1	Overrange ¹
:		:							:										
1702		851	0	0	1	1	0	1	0	1	0	0	1	1	0	0	0	1	
1700	390.26	850	0	0	1	1	0	1	0	1	0	0	1	0	0	0	0	0	Nominal range
1400	345.13	700	0	0	1	0	1	0	1	1	1	1	0	0	0	0	0	0	
1000	280.90	500	0	0	0	1	1	1	1	1	0	1	0	0	0	0	0	0	
600	212.02	300	0	0	0	1	0	0	1	0	1	1	0	0	0	0	0	0	
300	157.31	150	0	0	0	0	1	0	0	1	0	1	1	0	0	0	0	0	
200	138.50	100	0	0	0	0	0	1	1	0	0	1	0	0	0	0	0	0	
2	100.39	1	0	0	0	0	0	0	0	0	0	0	0	1	0	0	0	0	
-0	100.00	0	0	0	0	0	0	0	0	0	0	0	0	0	0	0	0	0	
-40	92.16	-20	1	1	1	1	1	1	1	0	1	1	0	0	0	0	0	0	
-80	84.27	-40	1	1	1	1	1	1	0	1	1	0	0	0	0	0	0	0	
-200	60.25	-100	1	1	1	1	1	0	0	1	1	1	0	0	0	0	0	0	
-202		-101	1	1	1	1	1	0	0	1	1	0	1	1	0	0	0	1	Overrange ¹
:		:							:										
-494		-247	1	1	1	1	0	0	0	0	1	0	0	1	0	0	0	1	
< -494		< -247	1	1	1	1	0	0	0	0	1	0	0	1	0	0	0	1	Overflow

¹ In the overrange, any rise in the characteristic curve is retained when the linearized nominal range is exited.

**Measuring Range,
Ni 100 Resistance
Sensors**

The table below shows the assignments of analog to digitized measured values for resistance sensors (Ni 100):

Table 8-16 Representation of Digitized Measured Values of the ET 200B-4/8AI for Ni 100 Resistance Sensors (Complement of Twos)

Units	Resistance in Ω	Temperature in °C	Digitized Measured Value											X	F	OV	Range		
			15	14	13	12	11	10	9	8	7	6	5					4	3
> 590		> 295	0	0	0	1	0	0	1	0	0	1	1	1	0	0	0	1	Overflow
590		295	0	0	0	1	0	0	1	0	0	1	1	1	0	0	0	1	Overrange ¹
:		:							:										
502		251	0	0	0	0	1	1	1	1	1	0	1	1	0	0	0	1	
500	289.2	250	0	0	0	0	1	1	1	1	1	0	1	0	0	0	0	0	Nominal range
498	288.1	249	0	0	0	0	1	1	1	1	1	0	0	1	0	0	0	0	
400	240.7	200	0	0	0	0	1	1	0	0	1	0	0	0	0	0	0	0	
200	161.8	100	0	0	0	0	0	1	1	0	0	1	0	0	0	0	0	0	
2	100.5	1	0	0	0	0	0	0	0	0	0	0	0	1	0	0	0	0	
0	100	0	0	0	0	0	0	0	0	0	0	0	0	0	0	0	0	0	
-2	99.5	-1	1	1	1	1	1	1	1	1	1	1	1	1	0	0	0	0	
-20	94.6	-10	1	1	1	1	1	1	1	1	0	1	1	0	0	0	0	0	
-80	79.1	-40	1	1	1	1	1	1	0	1	1	0	0	0	0	0	0	0	
-118	70	-59	1	1	1	1	1	1	0	0	0	1	0	1	0	0	0	0	
-120	69.5	-60	1	1	1	1	1	1	0	0	0	1	0	0	0	0	0	0	
-122		-61	1	1	1	1	1	1	0	0	0	0	1	1	0	0	0	1	Overrange ¹
:		:							:										
-210		-105	1	1	1	1	1	0	0	1	0	1	1	1	0	0	0	1	
< -210		< -105	1	1	1	1	1	0	0	1	0	1	1	1	0	0	0	1	Overflow
X		X	X	X	X	X	X	X	X	X	X	X	X	X	X	0	1	0	Wire break

¹ In the overrange, any rise in the characteristic curve is retained when the linearized nominal range is exited.

**Measuring Range,
Type E Thermo-
couples**

The table below shows the assignments of analog to digitized measured values for Type E thermocouples.

Table 8-17 Representation of Digitized Measured Values of the ET 200B-4/8AI with Linearization; Type E Thermocouples (Nickel-Chrome/Copper-Nickel, to IEC 548, Part 1; **Complement of Twos**)

Units	Thermal e. m. f. in mV ¹	Temperature in °C	Digitized Measured Value												X	F	OV	Range	
			15	14	13	12	11	10	9	8	7	6	5	4					2
> 1200			0	0	1	0	0	1	0	1	1	0	0	0	0	0	0	1	Overflow
1001		1001	0	0	0	1	1	1	1	1	0	1	0	0	1	0	0	1	Overrange ²
1000	76.358	1000	0	0	0	1	1	1	1	1	0	1	0	0	0	0	0	0	Nominal range
800	61.022	800	0	0	0	1	1	0	0	1	0	0	0	0	0	0	0	0	
400	28.943	400	0	0	0	0	1	1	0	0	1	0	0	0	0	0	0	0	
100	6.317	100	0	0	0	0	0	0	1	1	0	0	1	0	0	0	0	0	
1	0.059	1	0	0	0	0	0	0	0	0	0	0	0	0	1	0	0	0	
0	0	0	0	0	0	0	0	0	0	0	0	0	0	0	0	0	0	0	
-1	-0.059	-1	1	1	1	1	1	1	1	1	1	1	1	1	1	0	0	0	
-100	-5.237	-100	1	1	1	1	1	1	0	0	1	1	1	0	0	0	0	0	
-200	-8.824	-200	1	1	1	1	1	0	0	1	1	1	0	0	0	0	0	0	
-269	-9.833	-269	1	1	1	1	0	1	1	1	1	0	0	1	1	0	0	0	
-270	-9.835	-270	1	1	1	1	0	1	1	1	1	0	0	1	0	0	0	0	
-271		-271	1	1	1	1	0	1	1	1	1	0	0	0	1	0	0	1	Overrange ²
-273			1	1	1	1	0	1	1	1	0	1	1	1	1	0	0	1	Overflow
X		X	X	X	X	X	X	X	X	X	X	X	X	X	X	0	1	0	Wire break

¹ for a reference temperature 0 °C

² In the overrange, any rise in the characteristic curve is retained when the linearized nominal range is exited.

Measuring Range, Type J Thermocouples

The table below shows the assignments of analog to digitized measured values for Type J thermocouples.

Table 8-18 Representation of Digitized Measured Values of the ET 200B-4/8AI with Linearization: Type J Thermocouple (Iron/Copper-Nickel (Constantan), to IEC 584) (**Complement of Twos**)

Units	Thermal e. m. f. in mV ¹	Temperature in °C	Digitized Measured Value											X	F	OV	Range		
			15	14	13	12	11	10	9	8	7	6	5					4	3
1485			0	0	1	0	1	1	1	0	0	1	1	0	1	0	0	1	Overflow
1201		1201	0	0	1	0	0	1	0	1	1	0	0	0	1	0	0	1	Overrange ²
1200	69.536	1200	0	0	1	0	0	1	0	1	1	0	0	0	0	0	0	0	Nominal range
1000	57.942	1000	0	0	0	1	1	1	1	1	0	1	0	0	0	0	0	0	
500	27.388	500	0	0	0	0	1	1	1	1	1	0	1	0	0	0	0	0	
100	5.268	100	0	0	0	0	0	0	1	1	0	0	1	0	0	0	0	0	
1	0.05	1	0	0	0	0	0	0	0	0	0	0	0	0	1	0	0	0	
0	0	0	0	0	0	0	0	0	0	0	0	0	0	0	0	0	0	0	
-1	-0.05	-1	1	1	1	1	1	1	1	1	1	1	1	1	1	0	0	0	
-100	-4.632	-100	1	1	1	1	1	1	0	0	1	1	1	0	0	0	0	0	
-150	-6.499	-150	1	1	1	1	1	0	1	1	0	1	0	1	0	0	0	0	
-199	-7.868	-199	1	1	1	1	1	0	0	1	1	1	0	0	1	0	0	0	
-200	-7.890	-200	1	1	1	1	1	0	0	1	1	1	0	0	0	0	0	0	
-201		-201	1	1	1	1	1	0	0	1	1	0	1	1	1	0	0	1	Overrange ²
-273			1	1	1	1	0	1	1	1	0	1	1	1	1	0	0	1	Overflow
X		X	X	X	X	X	X	X	X	X	X	X	X	X	X	0	1	0	Wire break

¹ For a reference temperature of 0 °C (32 °F)

² In the overrange, any rise in the characteristic curve is retained when the linearized nominal range is exited.

Measuring Range, Type K Thermocouples

The table below shows the assignments of analog to digitized measured values for Type K thermocouples.

Table 8-19 Representation of Digitized Measured Values of the ET 200B-4/8AI with Linearization: Type K Thermocouples (Nickel-Chrome/Nickel-Aluminum, to IEC 584) (**Complement of Twos**)

Units	Thermal e. m. f. in mV ¹	Temperature in °C	Digitized Measured Value											X	F	OV	Range			
			15	14	13	12	11	10	9	8	7	6	5					4	3	2
> 2359			0	1	0	0	1	0	0	1	1	0	1	1	1	0	0	1	Overflow	
1370		1370	0	0	1	0	1	0	1	0	1	1	0	1	0	0	0	1	Overrange ²	
1369	54.773	1369	0	0	1	0	1	0	1	0	1	1	0	0	1	0	0	0	Nominal range	
1000	41.269	1000	0	0	0	1	1	1	1	1	1	0	1	0	0	0	0	0		0
500	20.640	500	0	0	0	0	1	1	1	1	1	0	1	0	0	0	0	0		
150	6.137	150	0	0	0	0	0	1	0	0	1	0	1	1	0	0	0	0		
100	4.095	100	0	0	0	0	0	0	1	1	0	0	1	0	0	0	0	0		
1	0.039	1	0	0	0	0	0	0	0	0	0	0	0	0	1	0	0	0		
0	0	0	0	0	0	0	0	0	0	0	0	0	0	0	0	0	0	0		
-1	-0.039	-1	1	1	1	1	1	1	1	1	1	1	1	1	1	0	0	0		
-100	-3.553	-100	1	1	1	1	1	1	0	0	1	1	1	0	0	0	0	0	Accuracy ≤ 2 K	
-101	-3.584	-101	1	1	1	1	1	1	0	0	1	1	0	1	1	0	0	0		
-150	-4.912	-150	1	1	1	1	1	0	1	1	0	1	0	1	0	0	0	0		
-200	-5.891	-200	1	1	1	1	1	0	0	1	1	1	0	0	0	0	0	0		
-201		-201	1	1	1	1	1	0	0	1	1	0	1	1	1	0	0	1	Overrange ²	
-273			1	1	1	1	0	1	1	1	0	1	1	1	1	0	0	1	Overflow	
X		X	X	X	X	X	X	X	X	X	X	X	X	X	X	0	1	0	Wire break	

¹ For a reference temperature of 0 °C (32 °F)

² In the overrange, any rise in the characteristic curve is retained when the linearized nominal range is exited.

**Measuring Range,
Type L Thermo-
couples**

The table below shows the assignments of analog to digitized measured values for Type L thermocouples.

Table 8-20 Representation of Digitized Measured Values of the ET 200B-4/8AI with Linearization: Type L Thermocouples (Iron/Copper-Nickel (Constantan), to DIN 43710) (**Complement of Twos**)

Units	Thermal e. m. f. in mV ¹	Temperature in °C	Digitized Measured Value										X	F	OV	Range			
			15	14	13	12	11	10	9	8	7	6					5	4	3
1361			0	0	1	0	1	0	1	0	1	0	0	0	1	0	0	1	Overflow
901		901	0	0	0	1	1	1	0	0	0	0	1	0	1	0	0	1	Overrange ²
900	53.14	900	0	0	0	1	1	1	0	0	0	0	1	0	0	0	0	0	Nominal range
500	27.85	500	0	0	0	0	1	1	1	1	1	0	1	0	0	0	0	0	
250	13.75	250	0	0	0	0	0	1	1	1	1	1	0	1	0	0	0	0	
100	+5.37	100	0	0	0	0	0	0	1	1	0	0	1	0	0	0	0	0	
1	0.05	1	0	0	0	0	0	0	0	0	0	0	0	0	1	0	0	0	
0	0	0	0	0	0	0	0	0	0	0	0	0	0	0	0	0	0	0	
-1	-0.05	-1	1	1	1	1	1	1	1	1	1	1	1	1	1	0	0	0	
-100	-4.75	-100	1	1	1	1	1	1	0	0	1	1	1	0	0	0	0	0	
-150	-6.60	-150	1	1	1	1	1	0	1	1	0	1	0	1	0	0	0	0	
-190	-7.86	-190	1	1	1	1	1	0	1	0	0	0	0	1	0	0	0	0	
-199	-8.12	-199	1	1	1	1	1	0	0	1	1	1	0	0	1	0	0	0	
-200		-200	1	1	1	1	1	0	0	1	1	1	0	0	0	0	0	1	Overrange ²
-273			1	1	1	1	0	1	1	1	0	1	1	1	1	0	0	1	Overflow
X		X	X	X	X	X	X	X	X	X	X	X	X	X	X	0	1	0	Wire break

¹ For a reference temperature of 0 °C (32 °F)

² In the overrange, any rise in the characteristic curve is retained when the linearized nominal range is exited.

**Measuring Range,
Type N Thermo-
couples**

The table below shows the assignments of analog to digitized measured values for Type N thermocouples.

Table 8-21 Representation of Digitized Measured Values of the ET 200B-4/8AI with Linearization; Type N Thermocouples (Nickel-Chrome-Silicium/Nickel-Silicium, to IEC 548-1; **Complement of Twos**)

Units	Thermal e. m. f. in mV ¹	Temperature in °C	Digitized Measured Value												X	F	OV	Range	
			15	14	13	12	11	10	9	8	7	6	5	4					
> 1550			0	0	1	1	0	0	0	0	0	1	1	1	0	0	0	1	Overflow
1301		1301	0	0	1	0	1	0	0	0	1	0	1	0	1	0	0	1	Overrange ²
1300	47.502	1300	0	0	1	0	1	0	0	0	1	0	1	0	0	0	0	0	Nominal range
1000	36.248	1000	0	0	0	1	1	1	1	1	0	1	0	0	0	0	0	0	
500	16.744	500	0	0	0	0	1	1	1	1	1	0	1	0	0	0	0	0	
100	2.774	100	0	0	0	0	0	0	1	1	0	0	1	0	0	0	0	0	
1	0.026	1	0	0	0	0	0	0	0	0	0	0	0	0	1	0	0	0	
0	0	0	0	0	0	0	0	0	0	0	0	0	0	0	0	0	0	0	
-1	-0.026	-1	1	1	1	1	1	1	1	1	1	1	1	1	0	0	0	0	
-100	-2.407	-100	1	1	1	1	1	1	0	0	1	1	1	0	0	0	0	0	
-250	-4.313	-250	1	1	1	1	1	0	0	0	0	0	1	1	0	0	0	0	
-269	-4.345	-269	1	1	1	1	0	1	1	1	1	0	0	1	1	0	0	0	
-270	-4.345	-270	1	1	1	1	0	1	1	1	1	0	0	1	0	0	0	0	
-271		-271	1	1	1	1	0	1	1	1	1	0	0	0	1	0	0	1	Overrange ²
-273			1	1	1	1	0	1	1	1	0	1	1	1	1	0	0	1	Overflow
X		X	X	X	X	X	X	X	X	X	X	X	X	X	X	0	1	0	Wire break

¹ for a reference temperature 0 °C

² In the overrange, any rise in the characteristic curve is retained when the linearized nominal range is exited.

Measuring Range, Type T Thermocouples

The table below shows the assignments of analog to digitized measured values for Type T thermocouples.

Table 8-22 Representation of Digitized Measured Values of the ET 200B-4/8AI with Linearization; Type T Thermocouples (Copper/Copper-Nickel, to IEC 548, Part 1; **Complement of Twos**)

Units	Thermal e. m. f. in mV ¹	Temperature in °C	Digitized Measured Value											X	F	OV	Range		
			15	14	13	12	11	10	9	8	7	6	5					4	3
> 540			0	0	0	1	0	0	0	0	1	1	1	0	0	0	0	1	Overflow
401		401	0	0	0	0	1	1	0	0	1	0	0	0	1	0	0	1	Overrange ²
400	20.869	400	0	0	0	0	1	1	0	0	1	0	0	0	0	0	0	0	Nominal range
399	20.807	399	0	0	0	0	1	1	0	0	0	1	1	1	1	0	0	0	
200	9.286	200	0	0	0	0	0	1	1	0	0	1	0	0	0	0	0	0	
100	4.277	100	0	0	0	0	0	0	1	1	0	0	1	0	0	0	0	0	
1	0.039	1	0	0	0	0	0	0	0	0	0	0	0	0	1	0	0	0	
0	0	0	0	0	0	0	0	0	0	0	0	0	0	0	0	0	0	0	
-1	-0.039	-1	1	1	1	1	1	1	1	1	1	1	1	1	1	0	0	0	
-100	-3.378	-100	1	1	1	1	1	1	0	0	1	1	1	0	0	0	0	0	
-200	-5.603	-200	1	1	1	1	1	0	0	1	1	1	0	0	0	0	0	0	
-269	-6.256	-269	1	1	1	1	0	1	1	1	1	0	0	1	1	0	0	0	
-270	-6.258	-270	1	1	1	1	0	1	1	1	1	0	0	1	0	0	0	0	
-271		-271	1	1	1	1	0	1	1	1	1	0	0	0	1	0	0	1	Overrange ²
-273			1	1	1	1	0	1	1	1	0	1	1	1	1	0	0	1	Overflow
X		X	X	X	X	X	X	X	X	X	X	X	X	X	X	0	1	0	Wire break

¹ for a reference temperature 0 °C

² In the overrange, any rise in the characteristic curve is retained when the linearized nominal range is exited.

**Measuring Range,
Type U Thermo-
couples**

The table below shows the assignments of analog to digitized measured values for Type U thermocouples.

Table 8-23 Representation of Digitized Measured Values of the ET 200B-4/8AI with Linearization; Type U Thermocouples (Copper/Copper-Nickel, to DIN 43710; **Complement of Twos**)

Units	Thermal e. m. f. in mV ¹	Temperature in °C	Digitized Measured Value												X	F	OV	Range	
			15	14	13	12	11	10	9	8	7	6	5	4					
> 850			0	0	0	1	1	0	1	0	1	0	0	1	0	0	0	1	Overflow
601		601	0	0	0	1	0	0	1	0	1	1	0	0	1	0	0	1	Overrange ²
600	34.31	600	0	0	0	1	0	0	1	0	1	1	0	0	0	0	0	0	Nominal range
599	34.24	599	0	0	0	1	0	0	1	0	1	0	1	1	1	0	0	0	
300	14.90	300	0	0	0	0	1	0	0	1	0	1	1	0	0	0	0	0	
100	4.25	100	0	0	0	0	0	0	1	1	0	0	1	0	0	0	0	0	
1	0.04	1	0	0	0	0	0	0	0	0	0	0	0	0	1	0	0	0	
0	0	0	0	0	0	0	0	0	0	0	0	0	0	0	0	0	0	0	
-1	-0.04	-1	1	1	1	1	1	1	1	1	1	1	1	1	1	0	0	0	
-100	-3.4	-100	1	1	1	1	1	1	0	0	1	1	1	0	0	0	0	0	
-150	-4.69	-150	1	1	1	1	1	0	1	1	0	1	0	1	0	0	0	0	
-199	-5.68	-199	1	1	1	1	1	0	0	1	1	1	0	0	1	0	0	0	
-200	-5.70	-200	1	1	1	1	1	0	0	1	1	1	0	0	0	0	0	0	
-201		-201	1	1	1	1	1	0	0	1	1	0	1	1	1	0	0	1	Overrange ²
-273			1	1	1	1	0	1	1	1	0	1	1	1	1	0	0	1	Overflow
X		X	X	X	X	X	X	X	X	X	X	X	X	X	X	0	1	0	Wire break

¹ for a reference temperature 0 °C

² In the overrange, any rise in the characteristic curve is retained when the linearized nominal range is exited.

8.4.5 Analog Value Representation, Operation with SIMATIC S7

Analog Value Representation, SIMATIC S7

If you operate the ET 200B-4/8AI with SIMATIC S7 the analog values are represented in complements of twos.

The table below shows the analog value representation of the ET 200B-4/8AI:

Table 8-24 Representation of an Analog Input Value as a Bit Pattern for SIMATIC S7 and ET 200B-4/8AI

	High Byte								Low Byte							
Bit Number	15	14	13	12	11	10	9	8	7	6	5	4	3	2	1	0
Analog Value Representation	SI	2 ¹⁴	2 ¹³	2 ¹²	2 ¹¹	2 ¹⁰	2 ⁹	2 ⁸	2 ⁷	2 ⁶	2 ⁵	2 ⁴	2 ³	2 ²	2 ¹	2 ⁰

Bit 15 has no significance for the amount of the measured value. It merely represents the sign.

Resolution

The resolution for the measured value depends directly on the integration time selected for the ET 200B-4/8A. In other words, the longer the integration time for an analog input channel, the higher is the resolution of the measured value.

If the resolution of an analog module is less than 15 bits, the analog value entry is left-aligned. The unused lower-value places are padded with "0".

Table 8-25 lists the possible resolutions of the ET 200B-4/8AI as a function of integration time. The "x" characters indicate the bits that are of no significance for the measured value.

Table 8-25 Possible Resolutions of Analog Values: ET 200B-4/8AI

Integration Time	Resolution in Bits	Analog Value															
		High Byte								Low Byte							
2.5 ms	9 (+SI)	SI	0	0	0	0	0	0	0	0	1	x	x	x	x	x	x
16.7 ms, 20 ms	12 (+SI)	SI	0	0	0	0	0	0	0	0	0	0	0	1	x	x	x
100 ms	14 (+SI)	SI	0	0	0	0	0	0	0	0	0	0	0	0	0	1	x

Voltage Measuring Ranges

The table below shows the representation of the digitized measuring values of the ET 200B-4/8AI for the measuring ranges: ± 80 mV, ± 250 mV, ± 500 mV and ± 1000 mV.

Table 8-26 Representation of Digitized Measured Values of the ET 200B-4/8AI (Measuring Ranges: ± 80 mV, ± 250 mV, ± 500 mV and ± 1000 mV)

Measuring Range ± 80 mV	Measuring Range ± 250 mV	Measuring Range ± 500 mV	Measuring Range ± 1 V	Units		Range
				Decimal	Hexadecimal	
≥ 94.074	≥ 293.98	≥ 587.96	≥ 1.17592	32767	7FFF _H	Overflow
94.071	293.97	587.94	1.17588	32511	7EFF _H	Overrange
:	:	:	:	:	:	
80.003	250.01	500.02	1.00004	27649	6C01 _H	Nominal range
80.000	250.00	500.00	1.000	27648	6C00 _H	
60.000	187.50	375.00	0.750	20736	5100 _H	Nominal range
:	:	:	:	:	:	
- 60.000	- 187.50	- 375.00	- 0.750	-20736	AF00 _H	Nominal range
- 80.000	- 250.00	- 500.00	-1.000	-27648	9400 _H	
- 80.003	- 250.01	- 500.02	- 1.00004	-27649	93FF _H	Underrange
:	:	:	:	:	:	
- 94.074	- 293.98	- 587.96	- 1.17592	-32512	8100 _H	Underrange
$\leq - 94.077$	$\leq - 293.99$	$\leq - 587.98$	$\leq - 1.17596$	-32768	8000 _H	

Measuring Range, Resistance Measurement

The table below shows the assignments of analog to digitized measured values for the resistance measuring ranges: 48 Ω, 150 Ω, 300 Ω and 600 Ω.

Table 8-27 Representation of Digitized Measured Values of the ET 200B-4/8AI for Resistance Measurement

Measuring Range 48 Ω	Measuring Range 150 Ω	Measuring Range 300 Ω	Measuring Range 600 Ω	Units		Range
				Decimal	Hexadecimal	
> 56.4427	> 176.3835	> 352.767	> 705.5339	32767	7FFF _H	Overflow
56.4427	176.3835	352.767	705.5339	32511	7EFF _H	Overrange
:	:	:	:	:	:	
48.0174	150.0054	300.0109	600.0217	27649	6C01 _H	Nominal range
48.000	150.000	300.000	600.000	27648	6C00 _H	
36.000	112.500	225.000	450.000	20736	5100 _H	Nominal range
:	:	:	:	:	:	
0.000	0.000	0.000	0.000	0	0 _H	Underrun
(Negative values physically impossible)				-32768	8000 _H	

**Measuring Range,
Pt 100 Resistance
Sensors**

The table below shows the assignments of analog to digitized measured values for resistance sensors (Pt 100).

Table 8-28 Representation of Digitized Measured Values of the ET 200B-4/8AI for Pt 100 Resistance Sensors

Temperature Range Standard Pt 100 850 °C	Decimal	Hexadecimal	Range
≥ 1000.1	32767	7FFF _H	Overflow
1000.0 : 850.1	10000 : 8501	2710 _H : 2135 _H	Overrange
850.0 : -200.0	8500 : -2000	2134 _H : F830 _H	Nominal range
-200.1 : -243.0	-2001 : -2430	F82F _H : F682 _H	Underrange
≤ - 243.1	-32768	8000 _H	Underrun

**Measuring Range,
Ni 100 Resistance
Sensors**

The table below shows the assignments of analog to digitized measured values for resistance sensors (Ni 100).

Table 8-29 Representation of Digitized Measured Values of the ET 200B-4/8AI for Ni 100 Resistance Sensors

Temperature Range Standard Ni 100 250 °C	Decimal	Hexadecimal	Range
≥ 295.1	32767	7FFF _H	Overflow
295.0 : 250.1	2950 : 2501	0B86 _H : 09C5 _H	Overrange
250.0 : -60.0	2500 : -600	09C4 _H : FDA8 _H	Nominal range
-60.1 : -105.0	-601 : -1050	FDA7 _H : FBE6 _H	Underrange
≤ - 105.1	-32768	8000 _H	Underrun

Measuring Range, Type E Thermo- couples

The table below shows the assignments of analog to digitized measured values for Type E thermocouples.

Table 8-30 Representation of Digitized Measured Values of the ET 200B-4/8AI with Linearization; Type E Thermocouples

Temperature Range in °C Type E	Decimal	Hexadecimal	Range
≥ 1200.1	32767	7FFF _H	Overflow
1200.0 : 1000.1	12000 : 10001	2EE0 _H : 2711 _H	Overrange
1000.0 : -270.0	10000 : -2700	2710 _H : F574 _H	Nominal range
≤ -270.1	-2701	F573 _H	Underrange

If wiring is incorrect or a sensor error in the negative range occurs, the analog-input module signals underrun when F0C4_H is undershot and outputs 8000_H.

Measuring Range, Type J Thermo- couples

The table below shows the assignments of analog to digitized measured values for Type J thermocouples.

Table 8-31 Representation of Digitized Measured Values of the ET 200B-4/8AI with Linearization; Type J Thermocouples

Temperature Range in °C Type J	Decimal	Hexadecimal	Range
≥ 1450.1	32767	7FFF _H	Overflow
1450.0 : 1200.1	14500 : 12001	38A4 _H : 2EE1 _H	Overrange
1200.0 : -210.0	12000 : -2100	2EE0 _H : F7CC _H	Nominal range
≤ -210.1	-2101	F7CB _H	Underrange

If wiring is incorrect or a sensor error in the negative range occurs, the analog-input module signals underrun when F3C1_H is undershot and outputs 8000_H.

**Measuring Range,
Type K Thermo-
couples**

The table below shows the assignments of analog to digitized measured values for Type K thermocouples.

Table 8-32 Representation of Digitized Measured Values of the ET 200B-4/8AI with Linearization; Type K Thermocouples

Temperature Range in °C Type K	Decimal	Hexadecimal	Range
≥ 1622.1	32767	7FFF _H	Overflow
1622.0 : 1372.1	16220 : 13721	3F5C _H : 3599 _H	Overrange
1372.0 : -270.0	13720 : -2700	3598 _H : F574 _H	Nominal range
≤ -270.1	-2701	F573 _H	Underrange
If wiring is incorrect or a sensor error in the negative range occurs, the analog-input module signals underrun when F0C4 _H is undershot and outputs 8000 _H .			

**Measuring Range,
Type L Thermo-
couples**

The table below shows the assignments of analog to digitized measured values for Type L thermocouples.

Table 8-33 Representation of Digitized Measured Values of the ET 200B-4/8AI with Linearization; Type L Thermocouples

Temperature Range in °C Type L	Decimal	Hexadecimal	Range
≥ 1150.1	32767	7FFF _H	Overflow
1150.0 : 900.1	11500 : 9001	2CEC _H : 2329 _H	Overrange
900.0 : -200.0	9000 : -2000	2328 _H : F830 _H	Nominal range
≤ -200.1	-2001	F82F _H	Underrange
If wiring is incorrect or a sensor error in the negative range occurs, the analog-input module signals underrun when F380 _H is undershot and outputs 8000 _H .			

**Measuring Range,
Type N Thermo-
couples**

The table below shows the assignments of analog to digitized measured values for Type N thermocouples.

Table 8-34 Representation of Digitized Measured Values of the ET 200B-4/8AI with Linearization; Type N Thermocouples

Temperature Range in °C Type N	Decimal	Hexadecimal	Range
≥ 1550.1	32767	7FFF _H	Overflow
1550.0 : 1300.1	15500 : 13001	3C8C _H : 32C9 _H	Overrange
1300.0 : -270.0	13000 : -2700	32C8 _H : F574 _H	Nominal range
≤ -270.1	-2701	F573 _H	Underrange

If wiring is incorrect or a sensor error in the negative range occurs, the analog-input module signals underrun when F0C4_H is undershot and outputs 8000_H.

**Measuring Range,
Type T Thermo-
couples**

The table below shows the assignments of analog to digitized measured values for Type T thermocouples.

Table 8-35 Representation of Digitized Measured Values of the ET 200B-4/8AI with Linearization; Type T Thermocouples

Temperature Range in °C Type T	Decimal	Hexadecimal	Range
≥ 540.1	32767	7FFF _H	Overflow
540.0 : 400.1	5400 : 4001	1518 _H : 0FA1 _H	Overrange
400.0 : 270.0	4000 : -2700	0FA0 _H : F574 _H	Nominal range
≤ -270.1	-2701	F573 _H	Underrange

If wiring is incorrect or a sensor error in the negative range occurs, the analog-input module signals underrun when F0C4_H is undershot and outputs 8000_H.

**Measuring Range,
Type U Thermo-
couples**

The table below shows the assignments of analog to digitized measured values for Type U thermocouples.

Table 8-36 Representation of Digitized Measured Values of the ET 200B-4/8AI with Linearization; Type U Thermocouples

Temperature Range in °C Type U	Decimal	Hexadecimal	Range
≥ 850.1	32767	7FFF _H	Overflow
850.0 : 600.1	8500 : 6001	2134 _H : 1771 _H	Overrange
600.0 : 200.0	6000 : -2000	1770 _H : F830 _H	Nominal range
≤ -200.1	-2001	F82F _H	Underrange
If wiring is incorrect or a sensor error in the negative range occurs, the analog-input module signals underrun when F380 _H is undershot and outputs 8000 _H .			

8.4.6 Block Diagram, Terminal Assignment and Technical Data

Block Diagram Simplified representation of potential for the ET 200B-4/8AI and TB8:

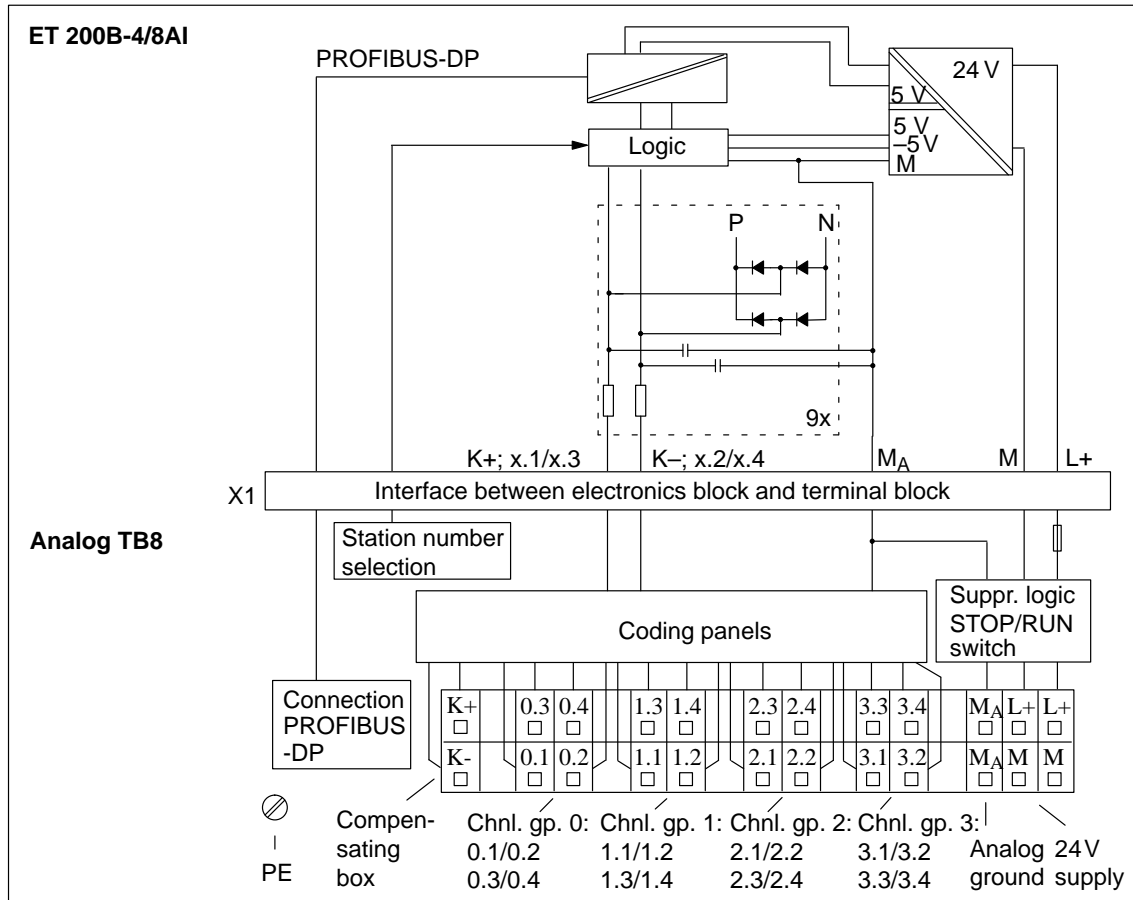

Figure 8-15 Block Diagram: ET 200B-4/8AI (6ES7 134-0KH01-0XB0) and TB8

Terminal Assignment

The table below contains the terminal assignments of the TB8 for ET 200B-4/8AI, depending on the sensor connected.

Table 8-37 Terminal Assignment of the TB8 for ET 200B-4/8AI (6ES7 134-0KH01-0XB0)

Terminal	Assignment When the Following are Connected		
	Thermocouple	Resistance Thermometer	Voltage Sensor
K+	Compensating box	Unassigned	Unassigned
K-	Compensating box	Unassigned	Unassigned
x.1	Measuring line (+)	Constant current line I _{C+}	Measuring line (+)
x.2	Measuring line (-)	Constant current line I _{C-}	Measuring line (-)
x.3	Measuring line (+)	Measuring line (+)	Measuring line (+)
x.4	Measuring line (-)	Measuring line (-)	Measuring line (-)
M _A	Analog ground (M _A)		
M _A	Analog ground (M _A)		
L+	Voltage supply, internal logic		
L+	Voltage supply, internal logic		
M	Voltage supply, internal logic		
M	Voltage supply, internal logic		

x = 0, 1, 2, 3

Note

Certain additional settings must be made for the input circuit by means of the coding plugs of the TB8. The settings of the coding plugs are illustrated in Figures 8-6 to 8-14.

Technical Data

The technical data of the ET200B-4/8AI electronics block are listed in the table below.

Technical specifications		Inputs	
Baud rates*	9.6/19.2/93.75/187.5/500/1500/3000/6000/12000 kbaud	Number of inputs	8 voltage inputs or 4 inputs for resistance thermometers and resistors or 8 inputs for thermocouples
Bus protocol	PROFIBUS-DP	Galvanic isolation to internal electronics	No
Galvanic isolation to the SINEC L2-DP bus	Yes	Galvanic isolation to voltage supply of internal logic	Yes
Power losses	Typically 2 W	Measured value ranges	
Weight (EB and TB)	Approx. 550 g (19.25 oz.)	• Thermocouples	Types E, J, K, L, N, T, U
Dimensions (EB and TB: W x H x D)	160 x 130 x 60	• Resistors	48 Ω 150 Ω 300 Ω 600 Ω
Diagnostics functions, alarms		• Resistance thermometers	Pt 100, Ni 100
Voltage monitoring	Green "RUN" LED	• Voltage	± 80 mV ± 250 mV ± 500 mV ± 1000 mV
Bus monitoring, SINEC L2-DP	Red "BF" LED	Permissible input voltage for voltage input (destruction limit)	32 V
Group diagnostics	Red "DIA" LED, parameterizable	Characteristic-curve linearization	
Alarms		• for thermocouples	Types E, J, K, L, N, T, U
• Limit-value alarm	Yes, parameterizable channels 0 and 2	• for thermal resistors	Pt 100 (standard range) Ni 100 (standard range)
• Diagnostics alarm	Yes, parameterizable	Linearization accuracy in nominal range for thermocouples	± 1°C
• End-of-cycle alarm	Yes, parameterizable	Connection of signal sensors	
Supply voltage for inputs and internal logic		• For voltage measurement	Possible
Supply voltage (L+)		• For resistance measurement:	
• Rated value	24 V DC	2-wire connection	Possible
• Permissible range	18.5 ... 30.2 V	4-wire connection	Possible
• Value for t < 0.5 s	35 V	Input resistance	≥ 10 MΩ
Current consumption from L+		Measured value representation	
• Logic	80 mA	• SIMATIC S5	12-bit complement of twos or 11-bit amount with sign (selectable)
* In operation with the IM 308-B, the maximum possible baud rate is 1500 kbaud.		• SIMATIC S7	Max. 14-bit complement of twos (depends on integration time)
		Overrange	Approx. 17.5 %

Inputs (continued)					Inputs (continued)	
Measuring principle	Integrating				Crosstalk between inputs	
Integration/conversion time/ resolution (per channel)					• At 50 Hz	50 dB
• Parameterizable	Yes				• At 60 Hz	50 dB
• Integration time in ms	2.5	16.7	20	100	Working error limit (over entire temperature range, in relation to input range)	
• Basic conversion time incl. integration time and offset measuring time in ms or	8	35	42	200	• 80 mV	± 1 %
Additional conversion time for wire-break monitoring in ms	10	10	10	10	• From 250 to 1000 mV	± 0.6 %
• Resolution in bits (incl. overrange)	9+	12+	12+	14+	• Thermocouples	± 10 K
	SI	SI	SI	SI	• Thermal resistors	± 5 K
• Noise suppression for interference frequency f1 in Hz	400	60	50	10	• Resistors	± 1 %
Permissible potential difference					Basic error limit (working error limit at 25 °C, in relation to input range)	
• Across inputs	Max. ± 1 V				• 80 mV	± 0.6 %
• Inputs to M _A (U _{CM})	Max. ± 1 V				• From 250 to 1000 mV	± 0.4 %
• M _A to PE or M	Max. 75 V DC/60 V AC				• Thermocouples	± 7 K
Error message in the event of					• Thermal resistors	± 3 K
• Range overshoot (overrange)	Yes				• Resistors	± 0.6 %
• Wire break of signal-sensor lines	Yes, for Pt 100, Ni 100, R, ± 80 mV, Type E, J, K, L, N, T, U thermocouples (parameterizable)				Temperature error (in relation to input range)	
Noise suppression for f = n × (f1 ± 1 %), (f1 = interference frequency)					± 0.005 %/K	
• Common-mode interference (U _{SS} < 3 V)	> 70 dB				Linearity error (in relation to input range)	
• Series-mode interference (peak value of interference < rated value of input range)	> 40 dB				± 0.05 %	
					Repeatability (in steady-state condition at 25 °C, in relation to input range)	
					± 0.05 %	
					Cable length	
					• Shielded	Max. 100 m

8.5 Electronics Block ET 200B-4AI (6ES7 134-0HF01-0XB0)

Characteristics

The ET 200B-4AI electronics block has the following characteristics:

- 4 inputs, floating to the supply voltage of the internal logic
- Measuring ranges:
 - Voltage: $\pm 1.25\text{ V}$, $\pm 2.5\text{ V}$, $\pm 5\text{ V}$, $\pm 10\text{ V}$,
 - Current: 0 to 20 mA, 4 to 20 mA, $\pm 20\text{ mA}$
- Measuring principle: successive approximation
- Supply voltage: 24 V DC
- Connectable sensors
 - Voltage sensors (2-wire connection)
 - Current sensors (2-wire connection)
- Measured-value range selection via COM ET 200 or STEP 7 or directly via parameterization telegram (see Chapter 4)

Dimensional Drawing

See Figure 8-4 for the precise dimensions.

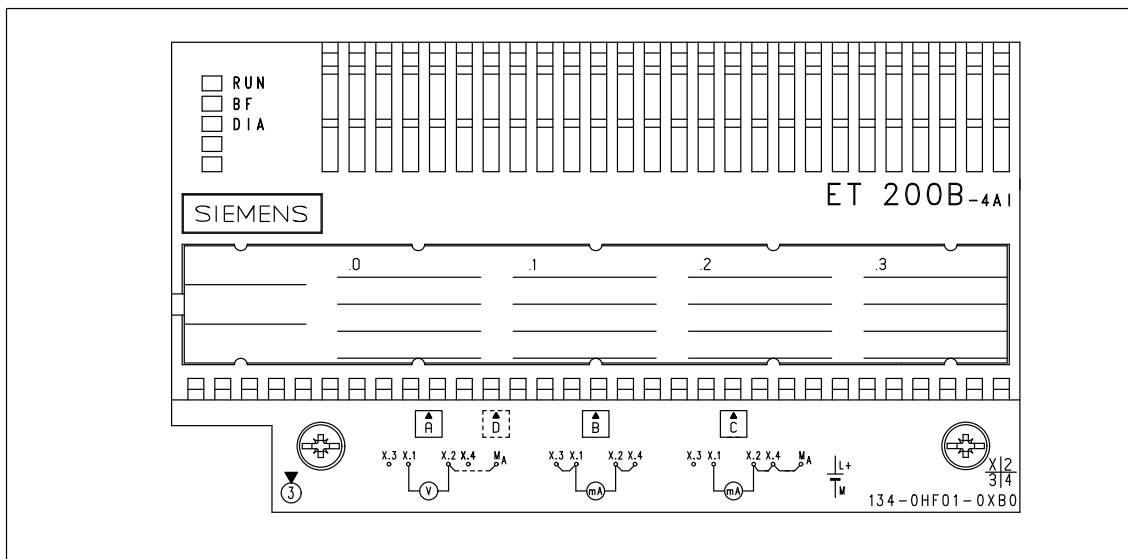

Figure 8-16 Front Elevation: ET 200B-4AI (6ES7 134-0HF01-0XB0)

List of Subsections

The following aspects of the ET 200B-4AI are described below:

In Section	you will find	on Page
8.5.1	Connecting transducers	8-53
8.5.2	Configuration options	8-61
8.5.3	Setting the operating mode	8-62
8.5.4	Analog-value representation, operation with SIMATIC S5	8-65
8.5.5	Analog-value representation, operation with SIMATIC S7	8-70
8.5.6	Schematic circuit diagram, terminal assignment and technical data	8-72

8.5.1 Connecting Transducers

Possible Connections

You can connect the following to the ET 200B-4AI:

- Up to 4 voltage sensors (2-wire connection)
- Up to 4 current sensors (2-wire connection)

Mixed configurations with different types of sensor are possible.

2-wire measuring transducers and 4-wire measuring transducers require a separate voltage supply (see Figures 8-21 and 8-22).

Input Circuit

There are two ways of measuring analog signals from current/voltage sensors:

- Floating-ground measurement
- Ground-referenced measurement

You set the input circuit for floating-ground or ground-referenced measurement by means of the coding plugs on the TB8 (one coding plug per channel).

Floating-Ground Measurement

In the case of floating-ground measurement (differential measurement), each signal line has its own signal reference conductor.

Differential measurement is required in the following cases:

- If the sensors are connected to different potentials and
- If the different signal sources are physically apart.

Note

The maximum permissible common mode voltage (V_{CM}) of the differential inputs to analog ground (M_A) is ± 1 V.

The maximum permissible voltage difference between M_A and PE must not exceed 75 V DC/60 V AC.

Avoid ground loops!

Ground-Referenced Measurement

In the case of ground-referenced measurement, all signal reference conductors in the TB8 are connected to a common reference point (analog ground M_A).

To avoid ground loops, galvanically isolated and ungrounded signal sources (thermocouples, voltage sources) are required.

Note

Connect M_A to PE() to enhance noise immunity in the case of ground-referenced measurement.

On the Following Pages

The following pages contain a connection example for every connection possibility and measuring principle. Please note the following rules.

Rules

Please note the following rules when connecting measured-value sensors to the ET 200B-4AI:

- The permissible potential difference at the differential input ($x.1 \leftrightarrow x.2$, $x = 0$ to 3) must not exceed ± 10 V.
- The maximum permissible common mode voltage (V_{CM}) between the differential inputs ($x.1 \leftrightarrow x.2$, $x=0$ to 3) and analog ground M_A is ± 1 V.
- The maximum permissible isolation voltage between analog ground (M_A) and PE () or between the reference potential of the supply voltage (M) is 75 V DC/60 V AC.
- You must short-circuit the connection terminals of unused voltage inputs and connect them to M_A (coding plug at position “D” for voltage sensors; position “C” implements the connection to M_A for current sensors).
- You must short-circuit terminals “K+” and “K-”. For this purpose, set the coding plug to the “C” position.

Note

Please note the explanation of shielding of analog lines in Sections 3.1 and 3.5.

Connecting Voltage Sensors

Voltage sensors for the following measured value ranges can be connected:
 $\pm 1.25\text{ V}$, $\pm 2.5\text{ V}$, $\pm 5\text{ V}$, $\pm 10\text{ V}$

Figures 8-17 and 8-18 show the two methods of connecting voltage sensors.

Floating-Ground Measurement

Figure 8-17 shows the 2-wire connection of voltage sensors (floating-ground measurement):

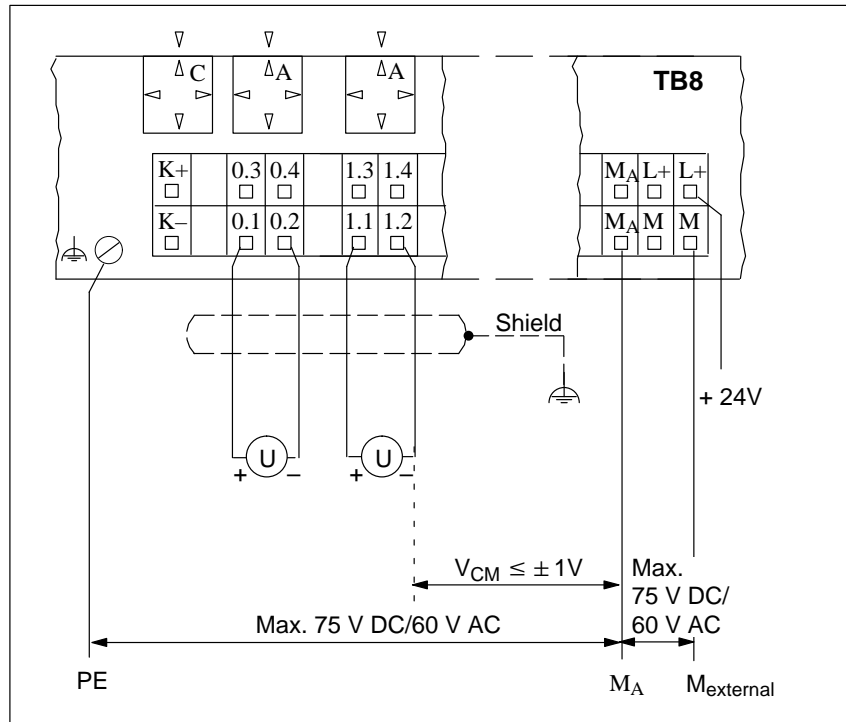
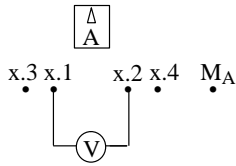
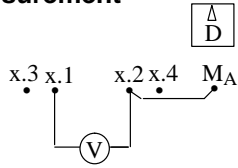

Figure 8-17 Two-Wire Connection of Voltage Sensors to ET 200B-4AI (Floating-Ground Measurement)

Note

The maximum permissible common mode voltage ($V_{CM} \leq \pm 1\text{ V}$) must not be exceeded at any of the differential inputs with reference to M_A .

Ground-Referenced Measurement



The 2-wire connection of voltage sensors (ground-referenced measurement) is shown below:

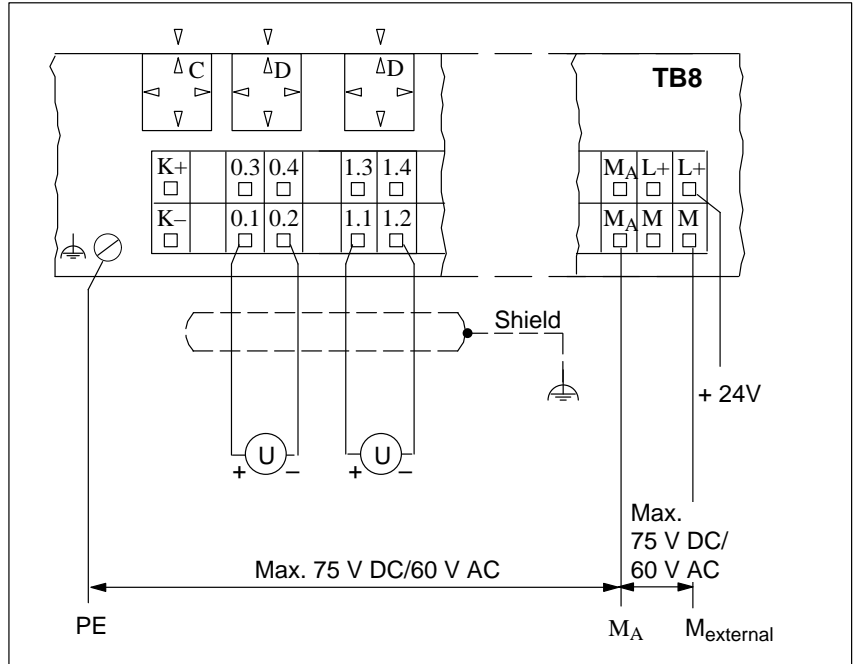

Figure 8-18 Two-Wire Connection of Voltage Sensors to ET 200B-4AI (Ground-Referenced Measurement)

Connecting Current Sensors

Current sensors for the following measured value ranges can be connected:
0 to 20 mA, 4 to 20 mA, ± 20 mA

Figures 8-19 and 8-20 show the two methods of connecting current sensors.

Floating-Ground Measurement

The 2-wire connection of current sensors (floating-ground measurement) is shown below:

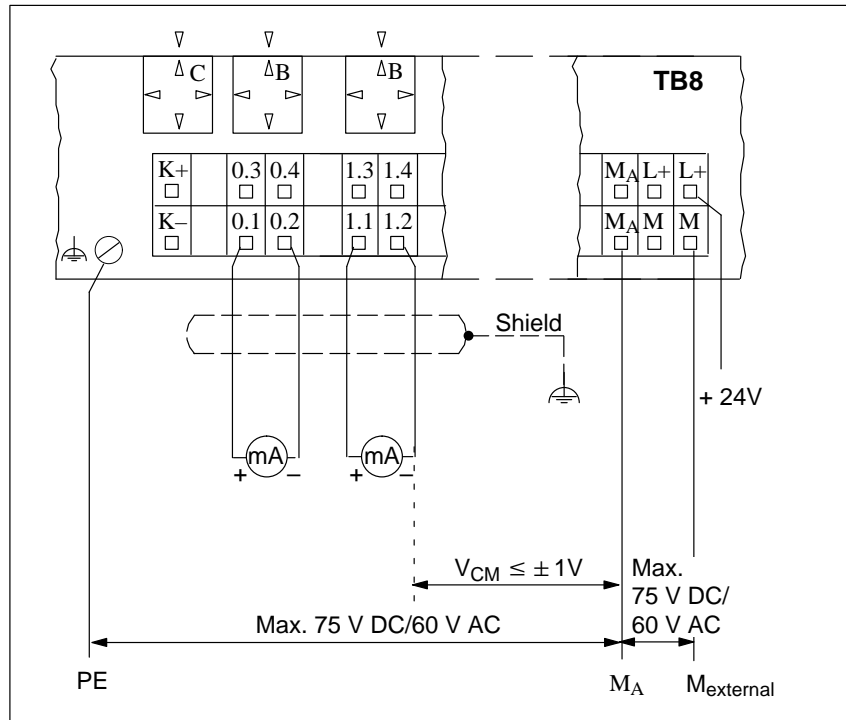
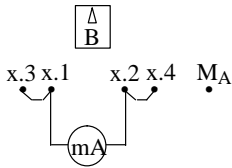
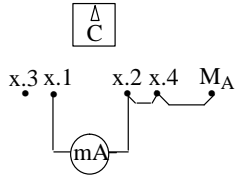

Figure 8-19 Two-Wire Connection of Current Sensors (Floating-Ground Measurement)

Note

The maximum permissible common mode voltage ($V_{CM} \leq \pm 1$ V) must not be exceeded at any of the differential inputs with reference to M_A .

Ground-Referenced Measurement



The 2-wire connection of current sensors (ground-referenced measurement) is shown below:

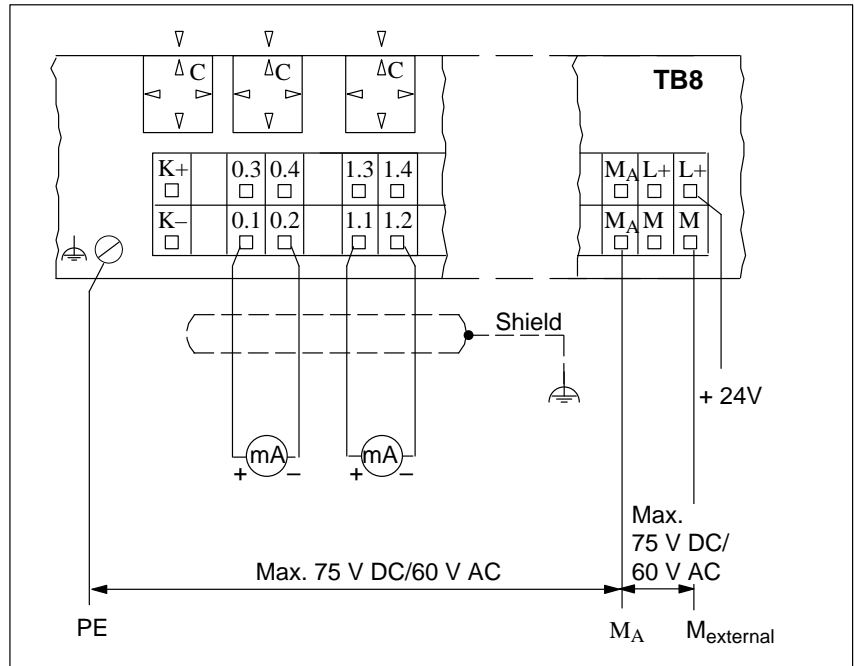

Figure 8-20 Two-Wire Connection of Current Sensors (Ground-Referenced Measurement)

Connecting 2-Wire and 4-Wire Measuring Transducers

The 2-wire and 4-wire measuring transducers receive a separate supply voltage.

2-wire measuring transducer converts the incoming measured variable into a current. 4-wire measuring transducers can be used to measure current and voltage.

2-Wire Measuring Transducers

The figure below shows how to connect the 2-wire measuring transducer as a current sensor:

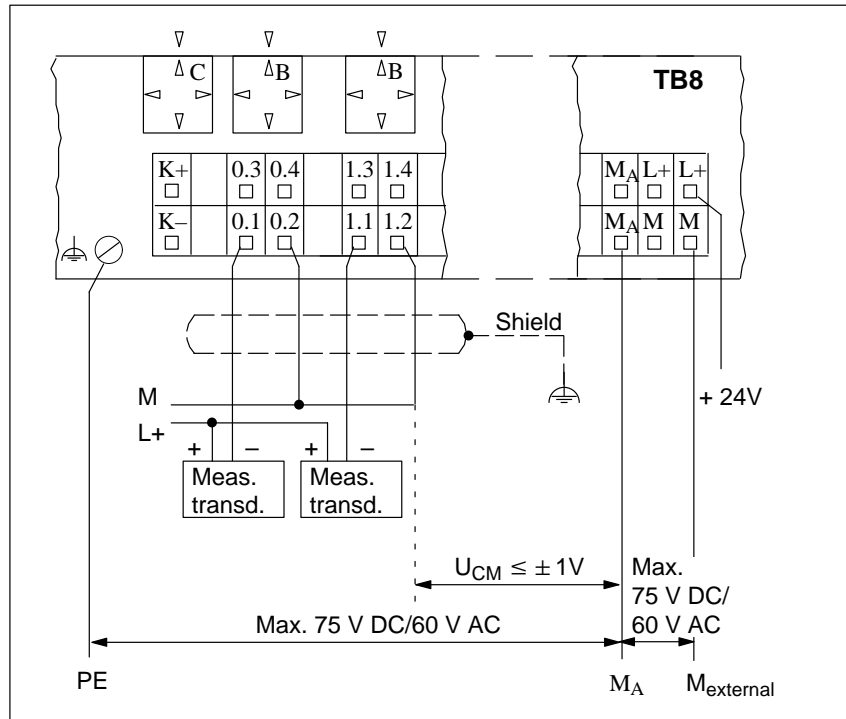
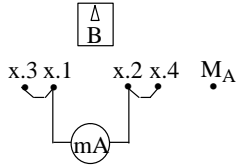

Figure 8-21 Connection of 2-Wire Measuring Transducer as Current Sensor

Note

The maximum permissible common mode voltage of the differential inputs to analog ground M_A is ($U_{CM} \leq \pm 1V$).

Avoid ground loops!

4-Wire Measuring Transducer

The figure below shows how to connect the 4-wire measuring transducer as a current sensor or voltage sensor:

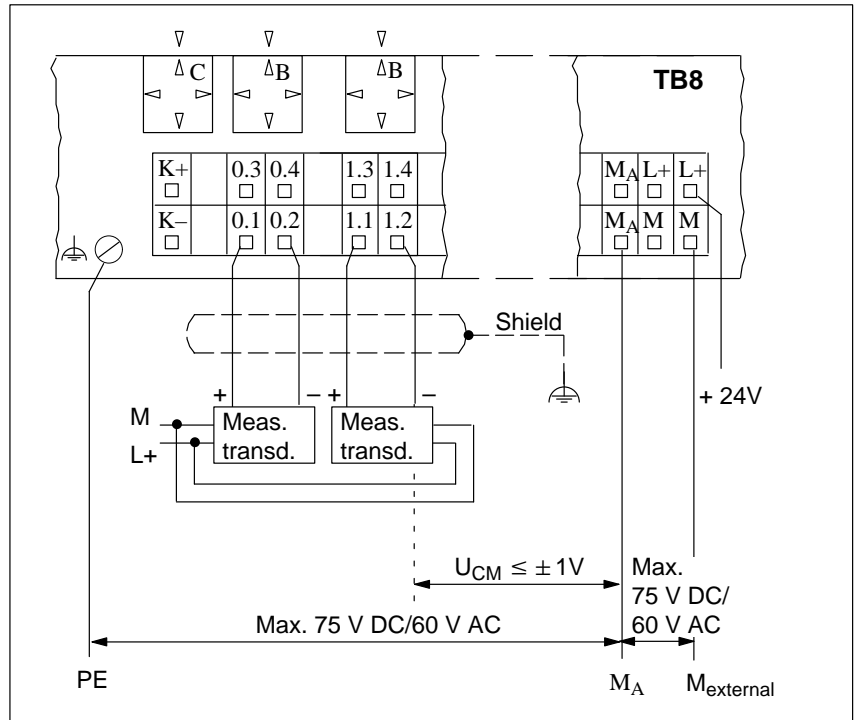
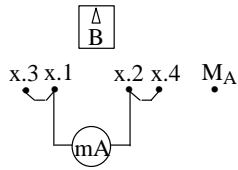

Figure 8-22 Connection of 4-Wire Measuring Transducer as Current Sensor or Voltage Sensor

Note

The maximum permissible common mode voltage of the differential inputs to analog ground M_A is ($U_{CM} \leq \pm 1V$).

8.5.2 Configuration Options

Type File The information in this section applies to the type file **SI8019BE.200**.
The type file contains the possible configurations. The configuration you choose depends on the wiring of the module.

Configuration Table 8-38 shows the possible configurations of the ET 200B-4AI with COM ET 200 Windows or STEP 7.

Table 8-38 lists only the slots for configuring the Input areas (slots 4 to 7). Slots 1 to 4 have the default value "004".

Table 8-38 Possible Configurations for the Input Areas of ET 200B-4AI

Config-uration	Terminals used				Length ¹ (in words)	Meaning
	Channel 0	Channel 1	Channel 2	Channel 3		
	0.1/0.2	1.1/1.2	2.1/2.2	3.0/3.1		
4AI	×	×	×	×	4	A start address is assigned for the entire module, addresses for 4 words are reserved. (= module addressing)
4 x 1AI	×	×	×	×	4	A separate start address can be assigned for each channel. (= single-channel addressing)
3 x 1AI	×	×	×		3	
2 x 1AI	×	×			2	
1 x 1AI	×				1	

¹ Length of user data

× = Connection of measuring lines

Diagnostics Diagnostics messages and diagnostics data (slave diagnostics) are returned only for the configured channels.

8.5.3 Setting the Operating Mode

Setting the Operating Mode

You set the operating mode of the ET 200B-4AI electronics block

- by means of the coding plugs on the TB8 terminal block and
- by means of the COM ET 200 or STEP7 parameterization software.

Coding Plugs

The coding plugs of the TB8 enable you to set the input circuit of the TB8 for analog value measurement of each individual channel of the ET 200B-4AI in accordance with the measured-value sensor connected and the desired mode of measurement.

The possible settings of the coding plugs are: "A", "B", "C" and "D".

For details of the relationships between the settings of the coding plugs and the mode of measurement and the measured-value sensors, see Section 8.5.1. Section 3.1 describes how to change the settings of the coding plugs.

Channel

Some parameters of the ET 200B-4AI listed on the following pages apply only to individual channels. Table 8-39 lists the assignment of TB8 terminals to channels.

Table 8-39 Assignment of Terminals to Channels

Channel	Terminals
Channel 0	Terminals 0.1/0.2
Channel 1	Terminals 1.1/1.2
Channel 2	Terminals 2.1/2.2
Channel 3	Terminals 3.1/3.2

Parameters

Table 8-40 shows all the parameters for parameterizing the ET 200B-4AI with COM ET 200 Windows or STEP 7.

You can set these parameters for the ET 200B-4AI if you use the type file **SI8019BE.200**.

Table 8-40 Parameters for ET 200B-4AI (6ES7 134-0HF01-0XB0)

Parameter	Explanation	Value Range
Diagnostics alarm	Diagnostics alarm enable for module	Disable Enable
Limit-value alarm	Limit-value alarm enable for module	Disable Enable
Diagnostics enable for channel 0	Diagnostics messages enabled separately for each channel	Disable Enable
Diagnostics enable for channel 1		
Diagnostics enable for channel 2		
Diagnostics enable for channel 3		
Wire break monitoring enable for channel 0	Wire break monitoring enabled separately for each channel group for measuring range 4 ... 20 mA	Disable Enable
Wire break monitoring enable for channel 1		
Wire break monitoring enable for channel 2		
Wire break monitoring enable for channel 3		
Measurement type and range for channel 0	You can set the measurement type and range separately for each channel For voltage measurement: For current measurement:	Channel not activated ± 10 V ± 5 V ± 2.5 V ± 1.25 V ± 20 mA 0 ... 20 mA 4 ... 20 mA
Measuring type and range for channel 1		
Measuring type and range for channel 2		
Measuring type and range for channel 3		
Representation of measured values	Sets representation of the analog measured values for module	SIMATIC S5 SIMATIC S7
Measured value representation: S5	Sets data format for analog value representation, SIMATIC S5	Complement of twos Amount with sign Binary

Table 8-40 Parameters for ET 200B-4AI (6ES7 134-0HF01-0XB0), continued

Parameter	Explanation	Value Range
Upper limit value for channel 0	Upper and lower limit values for each channel	0 – 32768 ... 32767
Lower limit value for channel 0		0 – 32768 ... 32767
Upper limit value for channel 2		0 – 32768 ... 32767
Lower limit value for channel 2		0 – 32768 ... 32767

■ : Default

8.5.4 Analog Value Representation, Operation with SIMATIC S5

Analog Value Representation, SIMATIC S7

If you operate the ET 200B-4AI with SIMATIC S5, you can utilize the analog value representation of SIMATIC S7 (higher measured-value resolution: max. 14 bits + sign). See Section 8.5.5 for the measured-value tables for analog value representation in SIMATIC S7.

Analog Value Representation, SIMATIC S5

Analog values can be represented in three data formats with the ET 200B-4AI:

- 12-bit complement of twos representation (range: –2048 to +2047 units)
- 11-bit amount and 1-bit sign (range: –2048 to +2047 units)
- 12-bit binary number (range: 0 to 4095 units)

The table below shows the analog value representation of the ET 200B-4AI:

Table 8-41 Representation of an Analog Input Value as a Bit Pattern (6ES7 134-0HF01-0XB0)

Bit number	High Byte								Low Byte							
	15	14	13	12	11	10	9	8	7	6	5	4	3	2	1	0
Analog value representation	SI	2 ¹¹	2 ¹⁰	2 ⁹	2 ⁸	2 ⁷	2 ⁶	2 ⁵	2 ⁴	2 ³	2 ²	2 ¹	2 ⁰	X	X	OV

Bits 0 to 2 and bit 15 have no significance for the amount of the measured value. See Table 8-42 for a detailed description of these bits.

Supplementary Bits

Bits 0 to 2 and bit 15 have the following meaning in the bit pattern of the analog input value:

Table 8-42 Description of the Bits (6ES7 134-0HF01-0XB0)

Bit	Meaning	Signal Status	Meaning of the Signal Status
OV	Overflow bit	1	Overrange ¹
SI	Sign	0	“+” sign
		1	“–” sign
X	Irrelevant	–	–

¹ In the event of overflow at one measuring point, the overflow bits of the other channels remain unaffected; this means the values of the other channels are correct and can be evaluated.

Voltage Measuring Ranges

The tables below show the assignments of analog to digitized measured values for the measuring ranges: $\pm 1.25\text{ V}$, $\pm 2.5\text{ V}$, $\pm 5\text{ V}$, $\pm 10\text{ V}$.

The ET 200B-4AI module (6ES7 134-0HF01-0XB0) does not have an over-range.

Table 8-43 Representation of Digitized Measured Values of the ET 200B-4AI (6ES7 134-0HF01-0XB0); Measuring Ranges: $\pm 1.25\text{ V}$, $\pm 2.5\text{ V}$, $\pm 5\text{ V}$, $\pm 10\text{ V}$; **Complement of Twos**

Units	Measured Value in V				Digitized Measured Value															X	X	OV	Range
	$\pm 1.25\text{V}$	$\pm 2.5\text{V}$	$\pm 5\text{V}$	$\pm 10\text{V}$	15	14	13	12	11	10	9	8	7	6	5	4	3	2	1				
2047	1.2494	2.4988	4.9976	9.9951	0	0	1	1	1	1	1	1	1	1	1	1	1	0	0	1	Nominal range		
2046	1.2488	2.4975	4.9951	9.9902	0	0	1	1	1	1	1	1	1	1	1	1	0	0	0				
:	:	:	:	:	:																		
1	0.0006	0.0012	0.0024	0.0049	0	0	0	0	0	0	0	0	0	0	0	0	1	0	0	0			
0	0.0000	0.0000	0.0000	0.0000	0	0	0	0	0	0	0	0	0	0	0	0	0	0	0	0			
-1	-0.0006	-0.0012	-0.0024	-0.0049	1	1	1	1	1	1	1	1	1	1	1	1	1	0	0	0			
:	:	:	:	:	:																		
-2047	-1.2494	-2.4988	-4.9976	-9.9951	1	1	0	0	0	0	0	0	0	0	0	0	1	0	0	0			
-2048	-1.2500	-2.5000	-5.0000	-10.000	1	1	0	0	0	0	0	0	0	0	0	0	0	0	0	1			

Table 8-44 Representation of Digitized Measured Values of the ET 200B-4AI (6ES7 134-0HF01-0XB0); Measuring Ranges: $\pm 1.25\text{ V}$, $\pm 2.5\text{ V}$, $\pm 5\text{ V}$, $\pm 10\text{ V}$; **Amount and Sign**

Units	Measured Value in V				SI	Digitized Measured Value															X	X	OV	Range
	$\pm 1.25\text{V}$	$\pm 2.5\text{V}$	$\pm 5\text{V}$	$\pm 10\text{V}$		15	14	13	12	11	10	9	8	7	6	5	4	3	2	1				
2047	1.2494	2.4988	4.9976	9.9951	0	0	1	1	1	1	1	1	1	1	1	1	1	0	0	1	Nominal range			
2046	1.2488	2.4975	4.9951	9.9902	0	0	1	1	1	1	1	1	1	1	1	1	0	0	0					
:	:	:	:	:	:																			
1	0.0006	0.0012	0.0024	0.0049	0	0	0	0	0	0	0	0	0	0	0	0	1	0	0	0				
0	0.0000	0.0000	0.0000	0.0000	0	0	0	0	0	0	0	0	0	0	0	0	0	0	0	0				
-1	-0.0006	-0.0012	-0.0024	-0.0049	1	0	0	0	0	0	0	0	0	0	0	0	1	0	0	0				
:	:	:	:	:	:																			
-2047	-1.2494	-2.4988	-4.9976	-9.9951	1	0	1	1	1	1	1	1	1	1	1	1	1	0	0	0				
-2048	-1.2500	-2.5000	-5.0000	-10.000	1	1	0	0	0	0	0	0	0	0	0	0	0	0	0	1				

Table 8-45 Representation of Digitized Measured Values of the ET 200B-4AI (6ES7 134-0HF01-0XB0; Measuring Ranges: $\pm 1.25\text{ V}$, $\pm 2.5\text{ V}$, $\pm 5\text{ V}$, $\pm 10\text{ V}$; **Binary**)

Units	Measured Value in V				Digitized Measured Value										X	X	OV	Range			
	$\pm 1.25\text{V}$	$\pm 2.5\text{V}$	$\pm 5\text{V}$	$\pm 10\text{V}$	15	14	13	12	11	10	9	8	7	6					5	4	3
4095	1.2494	2.4988	4.9976	9.9951	0	1	1	1	1	1	1	1	1	1	1	1	1	0	0	1	Nominal range
4094	1.2488	2.4975	4.9951	9.9902	0	1	1	1	1	1	1	1	1	1	1	1	0	0	0		
:	:	:	:	:	:										:	:	:				
2049	0.0006	0.0012	0.0024	0.0049	0	1	0	0	0	0	0	0	0	0	0	0	1	0	0	0	
2048	0.0000	0.0000	0.0000	0.0000	0	1	0	0	0	0	0	0	0	0	0	0	0	0	0	0	
2047	-0.0006	-0.0012	-0.0024	-0.0049	0	0	1	1	1	1	1	1	1	1	1	1	1	0	0	0	
:	:	:	:	:	:										:	:	:				
1	-1.2494	-2.4988	-4.9976	-9.9951	0	0	0	0	0	0	0	0	0	0	0	0	1	0	0	0	
0	-1.2500	-2.5000	-5.0000	-10.000	0	0	0	0	0	0	0	0	0	0	0	0	0	0	0	1	

Current Measuring Ranges

The tables below show the assignments of analog to digitized measured values for the measuring ranges: 0 ... 20 mA, 4 ... 20 mA, $\pm 20\text{ mA}$.

The ET 200B-4AI module (6ES7 134-0HF01-0XB0) does not have an over-range.

Table 8-46 Representation of Digitized Measured Values of the ET 200B-4AI (6ES7 134-0HF01-0XB0; Measuring Range: $\pm 20\text{ mA}$; **Complement of Twos**)

Units	Measured Value in mA	Digitized Measured Value										X	X	OV	Range										
		$\pm 20\text{ mA}$														15	14	13	12	11	10	9	8	7	6
2047	19.9902	0	0	1	1	1	1	1	1	1	1	1	1	1	1	1	1	0	0	1	Nominal range				
2046	19.9804	0	0	1	1	1	1	1	1	1	1	1	1	1	1	0	0	0	0						
:	:	:										:	:	:											
1	0.00976	0	0	0	0	0	0	0	0	0	0	0	0	0	1	0	0	0	0						
0	0.0000	0	0	0	0	0	0	0	0	0	0	0	0	0	0	0	0	0	0						
-1	-0.00976	1	1	1	1	1	1	1	1	1	1	1	1	1	1	1	0	0	0						
:	:	:										:	:	:											
-2047	-19.9902	1	1	0	0	0	0	0	0	0	0	0	0	0	1	0	0	0	0						
-2048	-20.0000	1	1	0	0	0	0	0	0	0	0	0	0	0	0	0	0	0	1						

Table 8-47 Representation of Digitized Measured Values of the ET 200B-4AI (6ES7 134-0HF01-0XB0; Measuring Range: ± 20 mA; Amount and Sign)

Units	Mea- sured Value in mA	SI	Digitized Measured Value											X	X	OV	Range			
			15	14	13	12	11	10	9	8	7	6	5					4	3	2
2047	19.9902	0	0	1	1	1	1	1	1	1	1	1	1	1	1	1	0	0	1	No- minal range
2046	19.9804	0	0	1	1	1	1	1	1	1	1	1	1	1	0	0	0	0		
:	:																			
1	0.00976	0	0	0	0	0	0	0	0	0	0	0	0	0	1	0	0	0		
0	0.0000	0	0	0	0	0	0	0	0	0	0	0	0	0	0	0	0	0		
-1	-0.00976	1	0	0	0	0	0	0	0	0	0	0	0	0	1	0	0	0		
:	:																			
-2047	-19.9902	1	0	1	1	1	1	1	1	1	1	1	1	1	1	0	0	0		
-2048	-20.0000	1	1	0	0	0	0	0	0	0	0	0	0	0	0	0	0	1		

Table 8-48 Representation of Digitized Measured Values of the ET 200B-4AI (6ES7 134-0HF01-0XB0; Measuring Range: ± 20 mA; Binary)

Units	Mea- sured Value in mA	SI	Digitized Measured Value											X	X	OV	Range		
			15	14	13	12	11	10	9	8	7	6	5					4	3
4095	19.9902	0	1	1	1	1	1	1	1	1	1	1	1	1	1	0	0	1	Nomina l range
4094	19.9804	0	1	1	1	1	1	1	1	1	1	1	1	0	0	0	0		
:	:																		
2049	0.00976	0	1	0	0	0	0	0	0	0	0	0	0	1	0	0	0		
2048	0.0000	0	1	0	0	0	0	0	0	0	0	0	0	0	0	0	0		
2047	-0.00976	0	0	1	1	1	1	1	1	1	1	1	1	1	0	0	0		
:	:																		
1	-19.9902	0	0	0	0	0	0	0	0	0	0	0	0	1	0	0	0		
0	-20.0000	0	0	0	0	0	0	0	0	0	0	0	0	0	0	0	1		

Table 8-49 Representation of Digitized Measured Values of the ET 200B-4AI (6ES7 134-0HF01-0XB0; Measuring Range: 0 ... 20 mA)

Units	Measured Value in mA	Digitized Measured Value ¹											X	X	OV	Range	
		15	14	13	12	11	10	9	8	7	6	5					4
	0 to 20 mA														2	1	0
4095	19.9951	0	1	1	1	1	1	1	1	1	1	1	1	1	0	0	1
4094	19.9902	0	1	1	1	1	1	1	1	1	1	1	1	0	0	0	0
:	:																
1	0.00488	0	0	0	0	0	0	0	0	0	0	0	0	1	0	0	0
0	0.00000	0	0	0	0	0	0	0	0	0	0	0	0	0	0	0	1

¹ Same representation for two's complement, amount and sign, and binary

Table 8-50 Representation of Digitized Measured Values of the ET 200B-4AI (6ES7 134-0HF01-0XB0; Measuring Range: 4 ... 20 mA)

Units	Measured Value in mA	Digitized Measured Value ¹											X	X	OV	Range	
		15	14	13	12	11	10	9	8	7	6	5					4
	4 to 20 mA														2	1	0
2559	19.992	0	1	0	0	1	1	1	1	1	1	1	1	1	0	0	1
2048	16.000	0	1	0	0	0	0	0	0	0	0	0	0	0	0	0	0
512	4.000	0	0	0	1	0	0	0	0	0	0	0	0	0	0	0	0
511	3.992	0	0	0	0	1	1	1	1	1	1	1	1	1	0	0	0
384	3.000	0	0	0	0	1	1	0	0	0	0	0	0	0	0	0	0
383	2.992	0	0	0	0	1	0	1	1	1	1	1	1	1	0	0	0
0	0.000	0	0	0	0	0	0	0	0	0	0	0	0	0	0	0	1

¹ Same representation for two's complement, amount and sign, and binary

Note

The measuring range 4 to 20 mA is resolved to 2048 units in the interval 512 to 2560. For a representation in the range 0 to 2048 units, 512 units must be subtracted per software.

8.5.5 Analog Value Representation, Operation with SIMATIC S7

Analog Value Representation, SIMATIC S7

If you operate the ET 200B-4AI with SIMATIC S7 the analog values are represented in complements of twos.

The table below shows the analog value representation of the ET 200B-4AI:

Table 8-51 Representation of an Analog Input Value as a Bit Pattern for SIMATIC S7 and ET 200B-4AI

	High Byte								Low Byte							
Bit Number	15	14	13	12	11	10	9	8	7	6	5	4	3	2	1	0
Analog Value Representation	SI	2 ¹⁴	2 ¹³	2 ¹²	2 ¹¹	2 ¹⁰	2 ⁹	2 ⁸	2 ⁷	2 ⁶	2 ⁵	2 ⁴	2 ³	2 ²	2 ¹	2 ⁰

Bit 15 has no significance for the amount of the measured value. It merely represents the sign.

Voltage Measuring Ranges

The table below shows the representation of the digitized measuring values of the ET 200B-4AI for the measuring ranges: ± 1.25 V, ± 2.5 V, ± 5 V and ± 10 V.

Table 8-52 Representation of Digitized Measured Values of the ET 200B-4AI (Measuring Ranges: ± 1.25 V, ± 2.5 V, ± 5 V and ± 10 V)

Measuring Range ± 1.25 V	Measuring Range ± 2.5V	Measuring Range ± 5 V	Measuring Range ± 10 V	Units		Range
				Decimal	Hexadecimal	
≥ 1.4699	≥ 2.9398	≥ 5.8796	≥ 11.759	32767	7FFF _H	Overflow
1.46986	2.9397	5.8794	11.7589	32511	7EFF _H	Overrange
: 1.25005	: 2.5001	: 5.0002	: 10.0004	: 27649	: 6C01 _H	
1.25	2.50	5.00	10.00	27648	6C00 _H	Nominal range
0.9375	1.875	3.75	7.50	20736	5100 _H	
: - 0.9375	: - 1.875	: - 3.75	: - 7.50	: -20736	: AF00 _H	
- 1.25	- 2.50	- 5.00	- 10.00	-27648	9400 _H	
- 1.25005	- 2.5001	- 5.0002	- 10.0004	-27649	93FF _H	Underrange
: - 1.4699	: - 2.9398	: - 5.8796	: - 11.759	: -32512	: 8100 _H	
≤ - 1.47	≤ - 2.94	≤ - 5.88	≤ - 11.76	-32768	8000 _H	Underrun

Current Measuring Ranges

The two tables below show the representation of the digitized measuring values of the ET 200B-4AI for the measuring ranges: ± 20 mA, 0 ... 20 mA and 4 ... 20 mA.

Table 8-53 Representation of Digitized Measured Values of the ET 200B-4AI (Measuring Range: ± 20 mA)

Measuring Range ± 20 mA	Units		Range
	Decimal	Hexadecimal	
≥ 23.5185	32767	7FFF _H	Overflow
23.518	32511	7EFF _H	Overrange
:	:	:	
20.0007	27649	6C01 _H	
20.000	27648	6C00 _H	Nominal range
15.000	20736	5100 _H	
:	:	:	
- 15.000	-20736	AF00 _H	
- 20.000	-27648	9400 _H	
- 20.0007	-27649	93FF _H	Underrange
:	:	:	
- 23.5185	-32512	8100 _H	
$\leq - 23.519$	-32768	8000 _H	Underrun

Table 8-54 Representation of Digitized Measured Values of the ET 200B-4AI (Measuring Ranges: 0 to 20 mA and 4 to 20 mA)

Measuring Range From 0 to 20 mA	Measuring Range From 4 to 20 mA	Units		Range
		Decimal	Hexadecimal	
≥ 23.5185	≥ 22.815	32767	7FFF _H	Overflow
23.518	22.814	32511	7EFF _H	Overrange
:	:	:	:	
20.0007	20.0006	27649	6C01 _H	
20.000	20.000	27648	6C00 _H	Nominal range
15.000	16.000	20736	5100 _H	
:	:	:	:	
0.000	4.000	0	0 _H	
-0.0007	3.9995	-1	FFFF _H	
:	:	:	:	Underrange
-3.5185	1.1852	-4864	ED00 _H	
≤ -3.5192	≤ 1.1846	-32768	8000 _H	Underrun

8.5.6 Block Diagram, Terminal Assignment and Technical Data

Schematic Circuit Diagram Simplified representation of potential for the ET 200B-4AI and TB8:

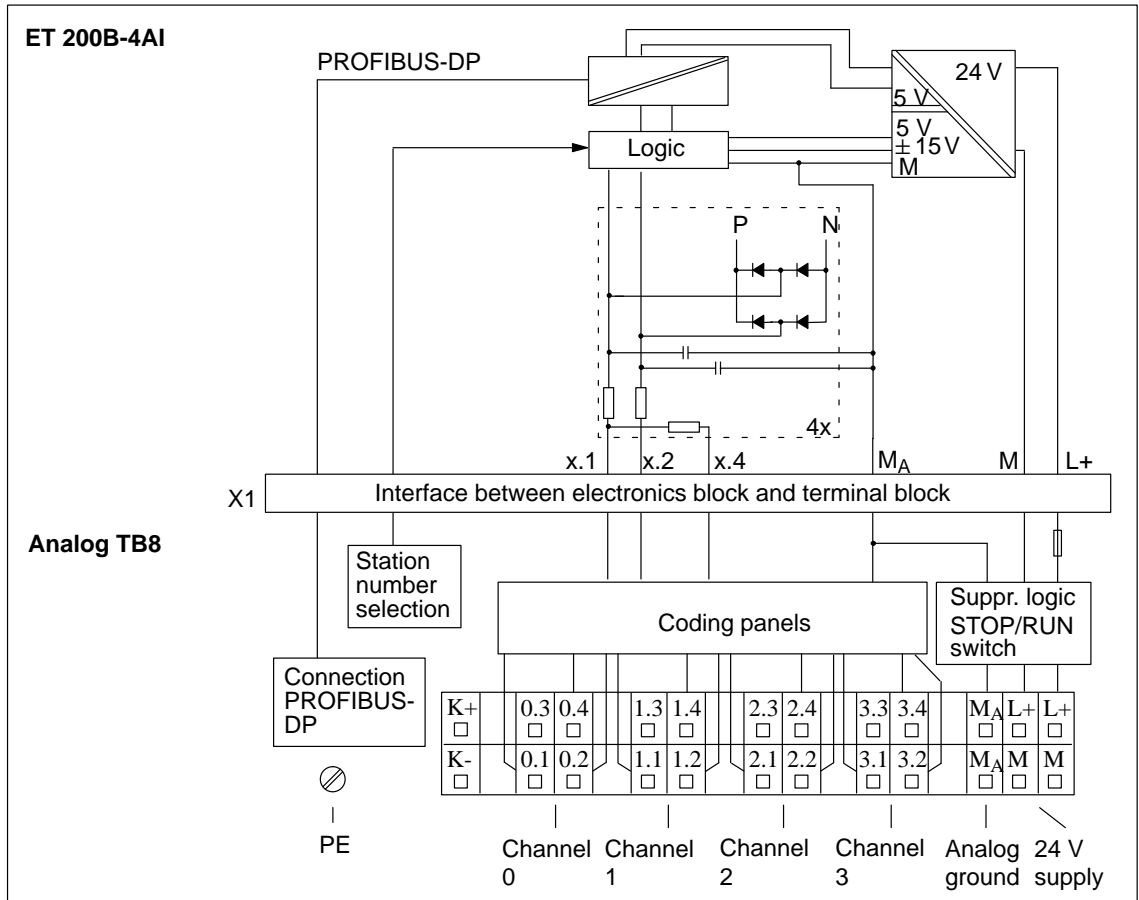

Figure 8-23 Block Diagram: ET 200B-4AI (6ES7 134-0HF10-0XB0) and TB8

Terminal Assignment

The table below contains the terminal assignments of the TB8 for ET 200B-4AI:

Table 8-55 Terminal Assignment of the TB8 for ET 200B-4AI (6ES7 134-0HF01-0XB0)

Terminal	Assignment
K+	Unassigned
K-	Unassigned
x.1	Measuring line (+)
x.2	Measuring line (-)
x.3	Unassigned
x.4	Connection, resistance measurement
M _A	Analog ground (M _A)
M _A	Analog ground (M _A)
L+	Voltage supply, internal logic
L+	Voltage supply, internal logic
M	Voltage supply, internal logic
M	Voltage supply, internal logic

x = 0, 1, 2, 3

Note

Certain additional settings must be made for the input circuit by means of the coding plugs of the TB8. The settings of the coding plugs are illustrated in Figures 8-17 to 8-22.

Technical Data

The technical data of the ET200B-4AI electronics block are listed in the table below.

Technical specifications		Inputs	
Baud rates*	9.6/19.2/93.75/187.5/500/ 1500/3000/6000/ 12000 kbaud	Number of inputs	4
Bus protocol	PROFIBUS-DP	Galvanic isolation to inter- nal electronics	No
Galvanic isolation to the SINEC L2-DP bus	Yes	Galvanic isolation to volt- age supply of internal logic	Yes
Power losses	Typically 1.8 W	Measured value ranges	
Weight (EB and TB)	Approx. 550 g (19.25 oz.)	• Voltage sensors	± 1.25 V ± 2.5 V ± 5 V ± 10 V
Dimensions (EB and TB: W x H x D)	160 x 130 x 60	• Current sensors	0 ... 20 mA 4 ... 20 mA ± 20 mA
Diagnostics functions, alarms		Connection of signal sensors	
Voltage monitoring	Green "RUN" LED	• For voltage measure- ment	Possible (2-wire connection)
Bus monitoring, SINEC L2-DP	Red "BF" LED	• For current measure- ment	Possible (2-wire connection)
Group diagnostics	Red "DIA" LED, parame- terizable	• For measuring trans- ducer	Possible, 2-wire- and 4-wire measuring trans- ducers
Alarms		Input resistance	
• Limit-value alarm	Yes, parameterizable channels 0 and 2	• Voltage measurement	≥ 100 KΩ
• Diagnostics alarm	Yes, parameterizable	• Current measurement	125 Ω
Supply voltage for inputs and internal logic		Measured value represen- tation	
Supply voltage (L+)		• SIMATIC S5	12-bit complement of twos or 11-bit amount with sign or 12-bit binary (select- able)
• Rated value	24 V DC	• SIMATIC S7	Max. 14-bit complement of twos (depends on in- tegration time)
• Permissible range	18.5 ... 30.2 V	Measuring principle	Successive approximation
• Value for t < 0.5 s	35 V	Conversion time	Max. 100 μs
Current consumption from L+		Cycle time of module	Approx. 5 ms
• Logic	70 mA	Permissible potential dif- ference	
* In operation with the IM 308-B, the maximum possible baud rate is 1500 kbaud.		• Across inputs of a channel	Max. ± 10 V
		• Inputs to M _A (U _{CM})	Max. ± 1 V
		• M _A to PE or M	Max. 75 V DC/60 V AC
		Error message in the event of	
		• Range overshoot (nominal range)	Yes
		• Wire break of signal- sensor lines	Only for measuring range 4 ... 20 mA

Inputs (continued)	
Noise suppression for $f = n$ x (50/60 Hz \pm 1%) n = 1, 2, ...	
• Common-mode interference ($U_{SS} < 1$ V)	min. 70 dB
Basic error limit	
• Voltage ranges	0.15 %
• Current range	0.20 %
Working error limit (0 ... 60 °C)	
• Voltage ranges	0.32 %
• Current range	0.41 %
Permissible input voltage (destruction limit)	Max. \pm 30 V (static) or \pm 75 V (pulse for max. 1ms and 1:20 sampling)
Permissible input current (destruction limit)	Max. 24 mA
Cable length	
• Shielded	Max. 100 m

8.6 Electronics Block ET 200B-4AO (6ES7 135-0HF01-0XB0)

Characteristics

The ET 200B-4AO electronics block has the following characteristics:

- 4 inputs, floating to the supply voltage of the internal logic
- Output ranges:
 - Voltage output: $\pm 10\text{ V}$, 0 ... 10 V
 - Current output: $\pm 20\text{ mA}$, 0 ... 20 mA, 4 ... 20 mA
- Supply voltage: 24 V DC
- Loads connectable in
 - 4-wire connection
 - 2-wire connection
- Output range selection via COM ET 200 or STEP 7 or directly via parameterization telegram (see Chapter 4)

Dimensional Drawing

See Figure 8-4 for the precise dimensions.

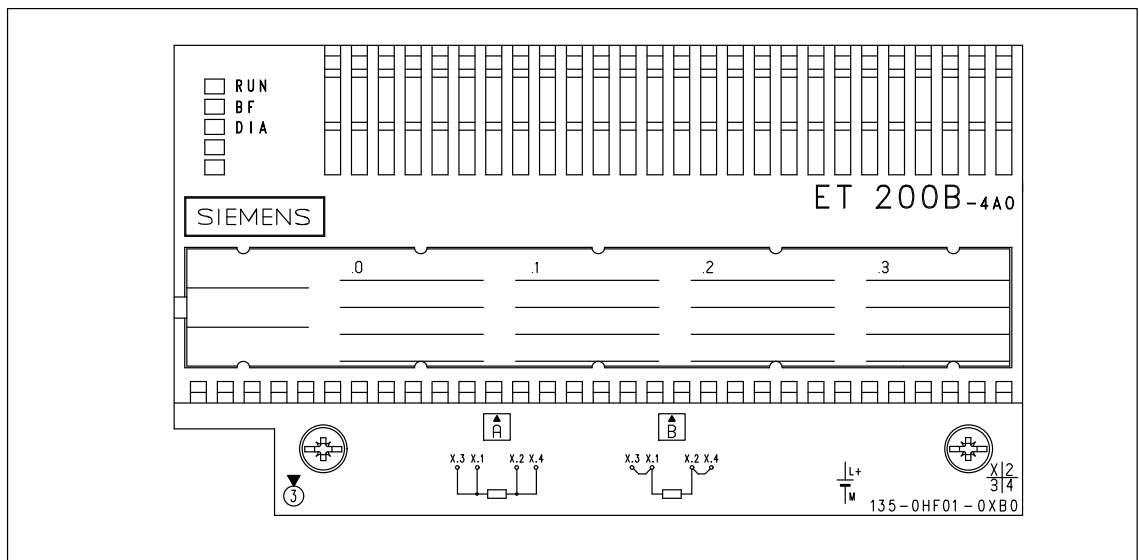

Figure 8-24 Front Elevation: ET 200B-4AO (6ES7 135-0HF01-0XB0)

List of Subsections

The following aspects of the ET 200B-4AO are described below:

In Section	you will find	on Page
8.6.1	Connecting loads	8-78
8.6.2	Configuration options	8-82
8.6.3	Setting the operating mode	8-83
8.6.4	Analog-value representation, operation with SIMATIC S5	8-85
8.6.5	Analog-value representation, operation with SIMATIC S7	8-87
8.6.6	Block diagram, pin assignment and technical data	8-89

8.6.1 Connecting Loads

Possible Connections

There are two methods of connecting loads to the ET 200B-4AO:

- 4-wire connection of loads
- 2-wire connection of loads

On the Following Pages

The following pages contain a connection example for every connection possibility. Please note the following rules.

Rules

Please note the following rules when connecting loads to the ET 200B-4AO:

- The output terminals $x.2$ ($x = 0$ to 3) have a fixed connection to analog ground (M_A).
If non-floating loads are connected to a common reference potential, please ensure minimum potential differences. Failure to do so can lead to undesired transient currents across the output module.
- You are recommended to connect floating-ground loads which are floating with reference to each other. In such cases, connect analog ground (M_A) with PE (\perp) to enhance noise immunity.
- The connection terminals of unused outputs are left open.
- You must short-circuit terminals “K+” and “K-”. For this purpose, set the coding plug to the “C” position.



Caution

If the supply voltage is below the lower tolerance limit, the output analog values can deviate from the specified values.

Note

Please note the explanation of shielding of analog lines in Sections 3.1 and 3.5.

4-Wire Connection of Loads (Voltage Output)

The voltage on the load is re-adjusted via two high-resistance sensor lines per channel (S+, S- at terminals x.3 and x.4). In this way, voltage drops of up to 3 V per line can be re-adjusted.

Please ensure that the sensor lines are connected directly to the load.

4-wire connection of loads for voltage output is shown below:

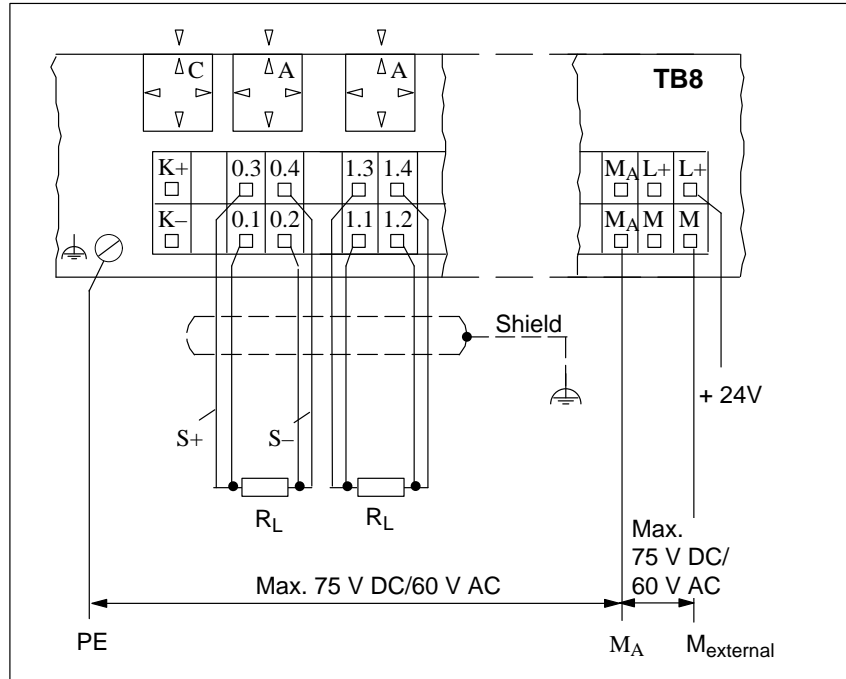
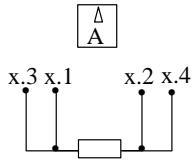

Figure 8-25 4-Wire Connection of Loads for Voltage Output

2-Wire Connection of Loads (Voltage Output)

The sensor lines are not required for 2-wire connection. Two-wire connection is possible for voltage output if the line resistance of the signal lines is negligible compared to the load resistance.

2-wire connection of loads for voltage output is shown below:

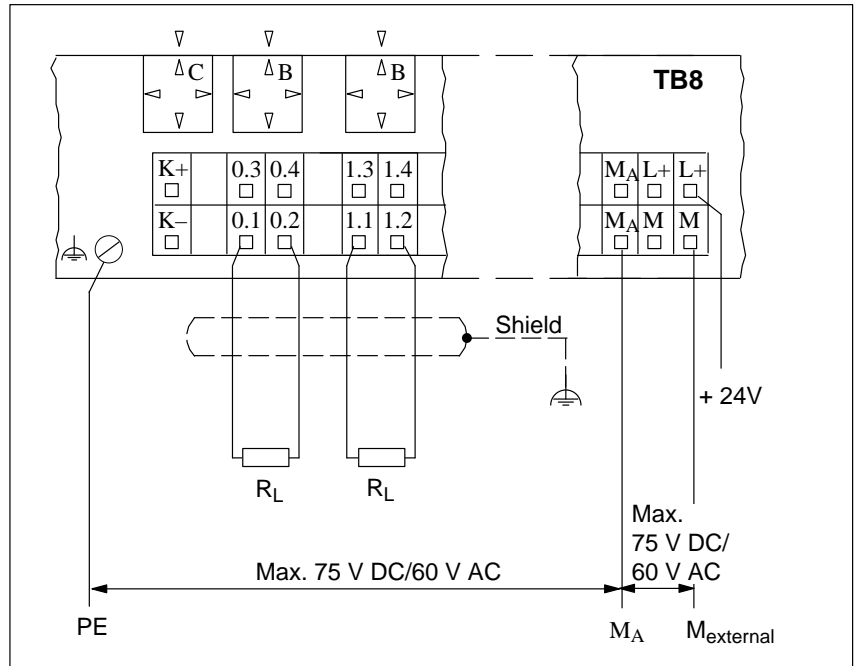
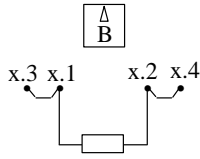

Figure 8-26 2-Wire Connection of Loads for Voltage Output

Two-Wire Connection of Loads (Current Output)

Two-wire connection of loads for current output is shown below:

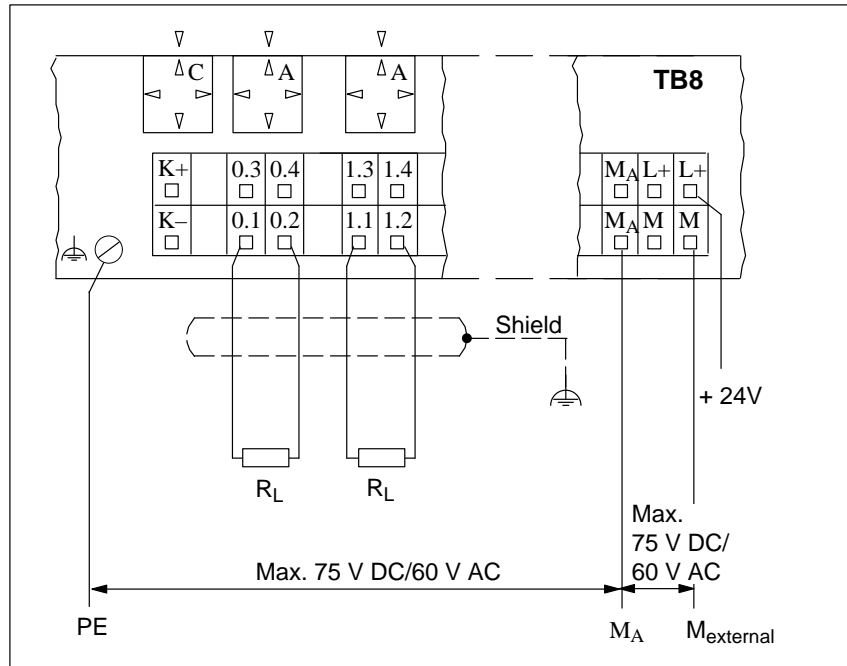
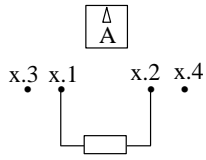

Figure 8-27 2-Wire Connection of Loads for Current Output

8.6.2 Configuration Options

Type File The information in this section applies to the type file **SI8018BE.200**.
The type file contains the possible configurations. The configuration you choose depends on the wiring of the module.

Configuration Table 8-56 shows the possible configurations of the ET 200B-4AO with COM ET 200 Windows or STEP 7.
Table 8-56 lists only the slots for configuring the output areas (slots 4 to 7). Slots 1 to 3 have the default value "004".

Table 8-56 Possible Configurations for the Output Areas of ET 200B-4AO

Config- uration	Terminals used								Length ¹ (in words)	Meaning
	Channel 0		Channel 1		Channel 2		Channel 3			
	0.1/ 0.2	0.3/ 0.4	1.1/ 1.2	1.3/ 1.4	2.1/ 2.2	2.3/ 2.4	3.0/ 3.1	3.3/ 3.4		
4AO	×	o	×	o	×	o	×	o	4	A start address is assigned for the entire module, addresses for 4 are reserved. (= module addressing)
4 x 1AO	×	o	×	o	×	o	×	o	4	
3 x 1AO	×	o	×	o	×	o			3	
2 x 1AO	×	o	×	o					2	
1 x 1AO	×	o							1	

¹ Length of user data
 × = Connection of load
 o = Connection of sensor lines for voltage measurement

Diagnostics Diagnostics messages and diagnostics data (slave diagnostics) are returned only for the configured channels.

8.6.3 Setting the Operating Mode

Setting the Operating Mode

You set the operating mode of the ET 200B-4AO electronics block

- by means of the coding plugs on the TB8 terminal block and
- by means of the COM ET 200 or STEP7 parameterization software.

Coding Plugs

The coding plugs of the TB8 enable you to set the output circuit for analog value output of each individual channel of the ET 200B-4AO.

The possible settings of the coding plugs are: "A", "B", "C" and "D".

For details of the relationships between the settings of the coding plugs and the output mode or load, see Section 8.6.1. Section 3.1 describes how to change the settings of the coding plugs.

Channel

Some parameters of the ET 200B-4AO listed on the following pages apply only to individual channels. Table 8-57 lists the assignment of TB8 terminals to channels.

Table 8-57 Assignment of Terminals to Channels

Channel	Terminals
Channel 0	Terminals 0.1/0.2
Channel 1	Terminals 1.1/1.2
Channel 3	Terminals 2.1/2.2
Channel 4	Terminals 3.1/3.2

Parameters

Table 8-58 shows all the parameters for parameterizing the ET 200B-4AO with COM ET 200 Windows or STEP 7.

You can set these parameters for the ET 200B-4AO if you use the type file **SI8018BE.200**.

Table 8-58 Parameters for ET 200B-4AO (6ES7 135-0HF01-0XB0)

Parameter	Explanation	Explanation
Diagnostics alarm	Diagnostics alarm enable for module	Disable Enable
Diagnostics enable for channel 0	Diagnostics messages enabled separately for each channel	Disable Enable
Diagnostics enable for channel 1		
Diagnostics enable for channel 2		
Diagnostics enable for channel 3		
Output value and range for channel 0	Type and range of output defined separately for each channel	± 10 V 0 ... 10 V ± 20 mA 0 ... 20 mA 4 ... 20 mA
Output value and range for channel 1	For voltage output:	
Output value and range for channel 2	For current output:	
Output value and range for channel 3		
Representation of output values	Sets representation of the analog values for module	SIMATIC S5 SIMATIC S7
Type of dummy value for channel 0	Defines the dummy value output for each channel in the event of communication interruption	Parameterizable Last value
Type of dummy value for channel 1		
Type of dummy value for channel 2		
Type of dummy value for channel 3		
Dummy value for channel 0	Sets dummy value for each channel	0 - 32786 ... 32767
Dummy value for channel 1		
Dummy value for channel 2		
Dummy value for channel 3		

■ : Default

8.6.4 Analog Value Representation, Operation with SIMATIC S5

Analog Value Representation, SIMATIC S7

If you operate the ET 200B-4AO with SIMATIC S5, you can utilize the analog value representation of SIMATIC S7. See Section 8.6.5 for the measured-value tables for analog value representation in SIMATIC S7.

Analog Value Representation, SIMATIC S5

Analog values are represented in complements of twos with the ET 200B-4AO.

The table below shows the analog value representation of the ET 200B-4AO:

Table 8-59 Representation of an Analog Output Value as a Bit Pattern (6ES7 135-0HF01-0XB0)

	High Byte								Low Byte							
Bit number	15	14	13	12	11	10	9	8	7	6	5	4	3	2	1	0
Analog value representation	SI	2 ¹⁰	2 ⁹	2 ⁸	2 ⁷	2 ⁶	2 ⁵	2 ⁴	2 ³	2 ²	2 ¹	2 ⁰	X	X	X	X

Bits 0 ... 3 and 15 have no significance for the amount of the measured value. See Table 8-60 for a detailed description of these bits.

Supplementary Bits

Bits 0 ... 3 and 15 have the following meaning in the bit pattern of the analog output value:

Table 8-60 Description of the Bits (6ES7 135-0HF01-0XB0)

Bit	Meaning	Signal Status	Meaning of the Signal Status
SI	Sign	0	“+” sign
		1	“-” sign
X	Irrelevant	–	–

Voltage and Current Output Ranges

The table below shows the assignments of analog to digitized output signals for the value ranges: ± 10 V, 0 ... 10 V, ± 20 mA, 0 ... 20 mA, 4 ... 20 mA.

Table 8-61 Analog Output Signals of the ET 200B-4AO (Value Ranges: ± 10 V, 0 ... 10 V, ± 20 mA, 0 ... 20 mA, 4 ... 20 mA; **Complement of Twos**)

Units	Output Value in mV					Digitized Output Value								Range				
	0 ... 20 mA	4 ... 20 mA	± 20 mA	0 ... 10 V	± 10 V	15	14	13	12	11	10	9	8		7	6	5	4
1249		23.52				0	1	0	0	1	1	1	0	0	0	0	1	Over-range
1204	23.52	:	23.52	11.758	11.758	0	1	0	0	1	0	1	1	0	1	0	0	
:	:	:	:	:	:							:						
1025	20.0195	20.016	20.2	10.0098	10.0098	0	1	0	0	0	0	0	0	0	0	0	1	
1024	20.0	20.0	20.0	10.00	10.00	0	1	0	0	0	0	0	0	0	0	0	0	Nominal range
1023	19.98	19.98	19.98	9.99	9.990	0	0	1	1	1	1	1	1	1	1	1	1	
512	10.0	12.0	10.0	5.00	5.000	0	0	1	0	0	0	0	0	0	0	0	0	
256	5.0	8.00	5.0	2.50	2.500	0	0	0	1	0	0	0	0	0	0	0	0	
1	0.0195	4.015	0.02	0.0098	0.0098	0	0	0	0	0	0	0	0	0	0	0	0	
0	0.0	4.0	0.0	0.0	0.000	0	0	0	0	0	0	0	0	0	0	0	0	
-1	0.0	3.984	-0.02	0.0	-0.0098	1	1	1	1	1	1	1	1	1	1	1	1	
-256	0.0	0.0	-05.0	0.0	-2.500	1	1	1	1	0	0	0	0	0	0	0	0	
-512	0.0	0.0	-10.0	0.0	-5.000	1	1	1	0	0	0	0	0	0	0	0	0	
-1024	0.0	0.0	-20.00	0.0	-10.000	1	1	0	0	0	0	0	0	0	0	0	0	
-1025	0.0	0.0	-20.02	0.0	-10.009	1	0	1	1	1	1	1	1	1	1	1	1	Over-range
:	:	:	:	:	:							:						
-1204	0.0	0.0	-23.52	0.0	-11.758	1	0	1	1	0	1	0	0	1	1	0	0	

8.6.5 Analog Value Representation, Operation with SIMATIC S7

Analog Value Representation, SIMATIC S7

Analog values are represented in complements of twos with the ET 200B-4AO for SIMATIC S7.

The table below shows the analog value representation ET 200B-4AO:

Table 8-62 Representation of an Analog Output Value as a Bit Pattern for SIMATIC S7 and ET 200B-4AO

	High Byte								Low Byte							
Bit number	15	14	13	12	11	10	9	8	7	6	5	4	3	2	1	0
Analog value representation	SI	2 ¹⁴	2 ¹³	2 ¹²	2 ¹¹	2 ¹⁰	2 ⁹	2 ⁸	2 ⁷	2 ⁶	2 ⁵	2 ⁴	2 ³	2 ²	2 ¹	2 ⁰

Bit 15 has no significance for the amount of the output value. It merely represents the sign.

Voltage Output Ranges

The table below shows the assignments of analog to digitized output signals for the value ranges: ± 10 V, 0 ... 10 V.

Table 8-63 Representation of Digitized Measured Values of the ET 200B-4AO (Output Ranges: 0 to 10 V and ± 10 V)

Output Range 0 to 10 V	Output Range ± 10 V	Units		Range
		Decimal	Hexa- decimal	
0	0	≥ 32512	≥ 7F00 _H	Overflow
11.7589	11.7589	32511	7EFF _H	Overrange
:	:	:	:	
10.0004	10.0004	27649	6C01 _H	
10.0000	10.0000	27648	6C00 _H	Nominal range
:	:	:	:	
0	0	0	0 _H	
0	:	:	:	
	:	- 6912	E500 _H	
	:	- 6913	E4FF _H	
	:	:	:	
	- 10.0000	- 27648	9400 _H	
	10.0004	- 27649	93FF _H	Underrange
	:	:	:	
	- 11.7593	- 32512	8100 _H	
	0	≤ - 32513	≤ 80FF _H	Underrun

Current Output Ranges

The table below shows the assignments of analog to digitized output signals for the value ranges: ± 20 mA, 0 ... 20 mA, 4 ... 20 mA.

Table 8-64 Representation of Digitized Measured Values of the ET 200B-4AO (Output Ranges: ± 20 mA, 0 to 20 mA and 4 to 20 mA)

Output Range ± 20 mA	Output Range 0 to 20 mA	Output Range 4 to 20 mA	Units		Range
			Decimal	Hexadecimal	
0	0	0	≥ 32512	$\geq 7F00_H$	Overflow
23.518	23.518	22.81	32511	7EFF _H	Overrange
:	:	:	:	:	
20.0007	20.0007	20.006	27649	6C01 _H	
20.000	20.000	20.000	27648	6C00 _H	Nominal range
0	:	:	:	:	
:	0	4.000	0	0 _H	
	0	:	:	:	
		0	- 6912	E500 _H	
		0	- 6913	E4FF _H	
- 20.000			:	:	
			- 27648	9400 _H	
			- 27649	93FF _H	Underrange
:			:	:	
- 23.519			- 32512	8100 _H	
0			$\leq - 32513$	$\leq 80FF_H$	Underrun

8.6.6 Block Diagram, Terminal Assignment and Technical Data

Block Diagram Simplified representation of potential for the ET 200B-4AO and TB8:

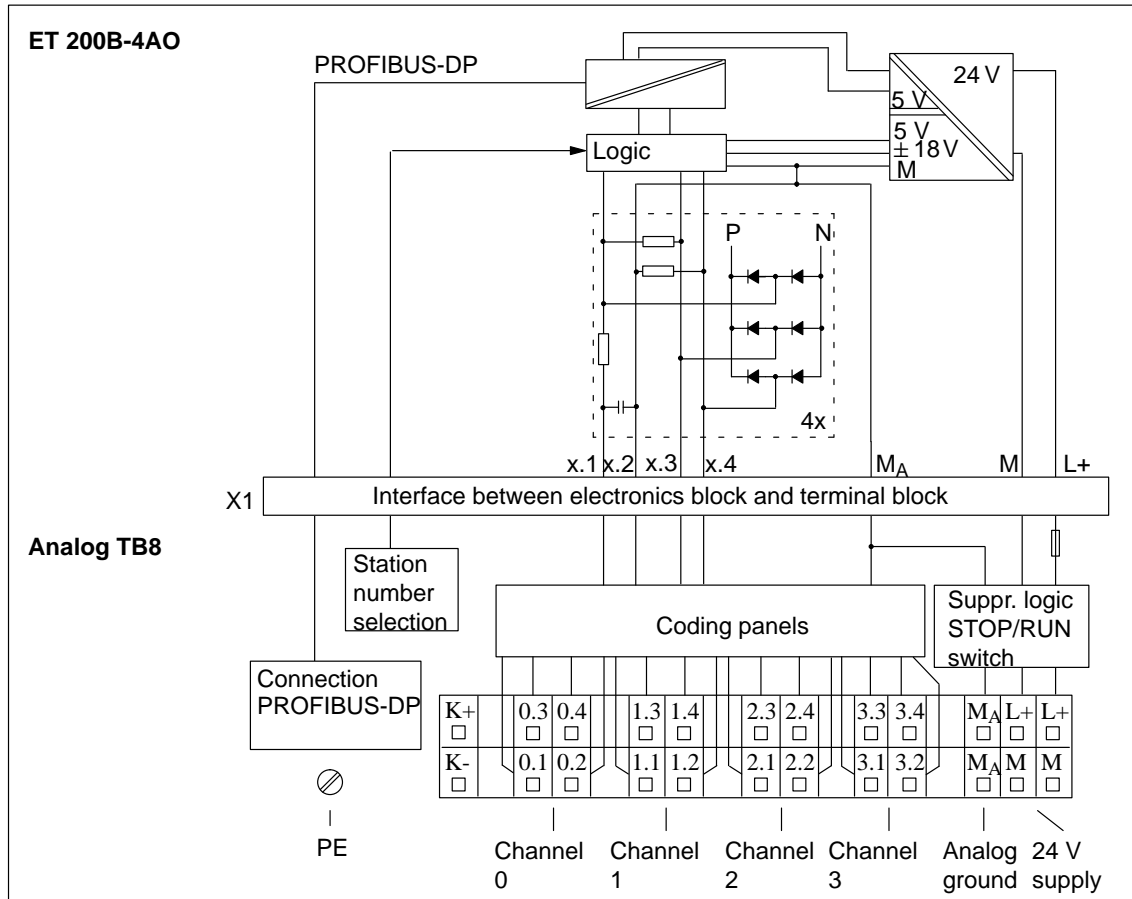

Figure 8-28 Block Diagram: ET 200B-4AO (6ES7 135-0HF01-0XB0) and TB8

Terminal Assignment

The table below contains the terminal assignments of the TB8 for ET 200B-4AO, depending on the circuit type used.

Table 8-65 Terminal Assignment of the TB8 for ET 200B-4AO (6ES7 135-0HF01-0XB0)

Terminal numbering TB8

Terminal	4-Wire Connection	2-Wire Connection
K+	Unassigned	
K-	Unassigned	
x.1	Analog output “voltage” (+)	Analog output “current or voltage” (+)
x.2	Analog output “voltage” (-)	Analog output “current or voltage” (-)
x.3	Sensor line (S+)	connected to x.1
x.4	Sensor line (S-)	connected to x.2
MA	Analog ground (MA)	
MA	Analog ground (MA)	
L+	Voltage supply for internal logic	
L+	Voltage supply for internal logic	
M	Voltage supply for internal logic	
M	Voltage supply for internal logic	

x = 0, 1, 2, 3

Note

You must make additional settings for the input circuits of the TB8 via coding plugs. See Figures 8-25 and 8-27 for the necessary settings of the coding plugs.

Technical Data

The technical data of the ET200B-4AO electronics block are listed in the table below.

Technical specifications		Outputs, continued	
Baud rates*	9.6/19.2/93.75/187.5/500/ 1500/3000/6000/ 12000 kbaud	Data input format	11-bit complement of twos
Bus protocol	PROFIBUS-DP	Overrange	Approx. 17.5 %
Galvanic isolation to SI- NEC L2-DP bus	Yes	Conversion time	Approx. 1 ms
Power losses	Typically 2.4 W	Settling time	
Weight (EB and TB)	Approx. 550 g (19.25 oz.)	<ul style="list-style-type: none"> For resistive load For capacitive load For inductive load 	0.1 ms 3.3 ms 0.5 ms
Dimensions (EB and TB: W x H x D)	160 x 130 x 60 mm (6.24 x 5.07 x 2.34 in.)	Permissible potential dif- ference	
Diagnostics functions, alarms		<ul style="list-style-type: none"> M_A to PE or M 	Max. 75 V DC/60 V AC
Voltage monitoring	Green "RUN" LED	Crosstalk between outputs	40 dB
Bus monitoring SINEC L2-DP	Red "BF" LED	Working error limit (over entire temperature range in relation to output range)	
Group diagnostics	Red "DIA" LED, parame- terizable	<ul style="list-style-type: none"> Voltage Current 	± 0.5 % ± 1 %
Diagnostics alarm	Yes, parameterizable	Basic error limit (working error limit at 25°C (77 °F) in relation to output range)	
Supply voltage for outputs and internal logic		<ul style="list-style-type: none"> Voltage Current 	± 0.2 % ± 0.3 %
Supply voltage (L+)		Temperature error (in rela- tion to output range)	± 0.02 %/K
<ul style="list-style-type: none"> Rated value Permissible range Value for $t < 0.5s$ 	24 V DC 18.5 to 30.2 V 35 V	Linearity error (in relation to output range)	± 0.05 %
Current consumption from L+		Repeatability (in steady- state condition at 25°C (77 °F), in relation to output range)	± 0.05 %
<ul style="list-style-type: none"> Logic 	Max. 200 mA	Output ripple (in relation to output range)	± 0.05 %
Outputs		Voltage output	
Number of outputs	4	<ul style="list-style-type: none"> Short-circuit protec- tion Short-circuit current 	Yes, max. 1 output simul- taneously Max. 25 mA
Galvanic isolation to inter- nal electronic circuits	No	Current output	
Galvanic isolation to volt- age supply of internal logic	Yes	<ul style="list-style-type: none"> Idle voltage 	Max. 18 V
Output ranges		Cable length	
<ul style="list-style-type: none"> Voltage range Current ranges 	± 10 V, 0 to 10 V ± 20 mA, 0 to 20 mA, 4 to 20 mA	<ul style="list-style-type: none"> Shielded 	Max. 100 m (328 ft.)
Connection type	2- or 4-wire connection		
Load resistance			
<ul style="list-style-type: none"> Voltage output Load impedance for current output Capacitive load Inductive load 	Min. 3.3 k Ω Max. 300 Ω Max. 1 μ F Max. 1 mH		

* In operation with the IM 308-B, the maximum possible baud rate is 1500 kbaud.

Type Files and GSD Files

A

In this Chapter

In order to operate an ET 200B module you require

- a type file for operation with COM ET 200 V4.x, COM ET 200 Windows or STEP 7
- or
- a GSD file for operation with PROFIBUS-DP masters from Siemens or other vendors.

Section	Describes	Page
A.1	Type files of the ET 200B modules	A-2
A.2	GSD files of the ET 200B modules	A-4

A.1 Type Files of the ET 200B Modules

Type File COM ET 200 V4.x, COM ET 200 Windows and STEP 7 require a type file for each ET 200B module (DP slave). The type file contains the definitions of all the module's characteristics.

Before you start working with the software, make sure that the type file of the ET 200B module is installed in a type-file directory recognized by the software.

Provision of Type Files All the type files needed to start ET 200B with COM ET 200 V4.x, COM ET 200 Windows and STEP 7 are available in the Interface Center. The modem number to dial is: +49 (0911) 737972

Digital Modules The designations of the type files for the digital ET 200B modules are as follows:

Table A-1 Designations of Type Files for Digital Modules

Station Type	Type File for COM ET 200 V4.x	Type File for COM ET 200 Windows and STEP 7 ¹
B-16DI DP	SI0001TE.200	SI0001AX.200
B-32DI DP	SI0004TE.200	SI0004AX.200
B-32DI.2 DP	SI000CTE.200	SI000CAX.200
B-16DO DP	SI0002TE.200	SI0002AE.200
B-16DO/2A DP	SI0005TE.200	SI0005AE.200
B-32DO DP	SI000DTE.200	SI000DAE.200
B-8DI/8DO DP	SI000BTE.200	SI000BAE.200
B-8DI/8DO HWA DP	SI0010TE.200	SI0010AE.200
B-16DI/16DO DP	SI000ATE.200	SI000AAE.200
B-24DI/8DO DP	SI000FTE.200	SI000FAE.200
B-24DI/8DO.2 DP	SI000ETE.200	SI000EAE.200
B-16DI-AC DP	SI0019TE.200	SI0019TX.200
B-16DO-AC DP	SI001ATE.200	SI001ATX.200
B-16RO-AC DP	SI001CTE.200	SI001CTX.200
B-8DI/8RO-AC DP	SI001DTE.200	SI001DTX.200
B-8RO DP	SI0003TE.200	SI0003AX.200

¹ These type files are valid for the digital modules described in this manual (order numbers are listed in Appendix F), even if the type files contain some order numbers of fully compatible predecessor modules.

Analog Modules

The designations of the type files for the analog ET 200B modules are as follows:

Table A-2 Designations of Type Files for Analog Modules

Station Type (in COM ET 200)		Type File for COM ET 200 V4.x	Type File for COM ET 200 Windows and STEP 7
B-4/8AI	DP	SI801ATE.200	SI801AAE.200
B-4AI	DP	SI8019TE.200	SI8019AE.200
B-4AO	DP	SI8018TE.200	SI8018AE.200
B-4/8AI-2	DP	–	SI801ABE.200
B-4AI-2	DP	–	SI8019BE.200
B-4AO-2	DP	–	SI8018BE.200

SIxxxxBE.200

There are two type-file version for configuring analog modules with COM ET 200 Windows (SIxxxxAE.200 and SIxxxxBE.200).

You can use either version. The SIxxxxBE.200 version supports additional functions for analog modules (alarms, dummy-value output for 4AO) and additional measuring ranges.

The SIxxxxBE.200 version now also supports single-channel addressing.

Installation

The manuals on the software contain notes on installation.

Note

The type files listed in Tables A-1 and A-2 are valid for the modules described in this manual (order numbers are listed in Appendix F), even if the type files contain the order numbers of predecessor modules!

A.2 GSD Files of the ET 200B Modules

GSD File	You need a device master data file, or GSD file to EN 50170, Part 3 to connect ET 200B modules to DP masters which cannot process the type files (e.g. DP masters from other vendors. The GSD file contains the definitions of all slave-specific characteristics.
Provision of GSD Files	<p>All GSD files for ET 200B are available on a diskette which you can order, quoting the following order number:</p> <p>Diskette with GSD files: 6ES7 190-1AA00-0AA0</p> <p>You can also fetch the GSD files by modem from the Interface Center: the modem number to dial is:</p> <p>Tel.: +49 (0911) 737972</p>
Major Characteristics	In case the GSD file is not available, the major characteristics of the ET 200B modules are listed in the tables below. This information will suffice to start ET 200B with a CP 5431, for example.

**16DI, 32DI, 16DO
and 16DO/2A**

The table below lists the master data of the ET 200B modules: 16DI, 32DI, 32DI 0.2 ms, 16DO and 16DO/2A.

Table A-3 Characteristics according to EN 50170, Part 3 for ET 200B-16DI, ET 200B-32DI, ET 200B-32DI 0.2ms, ET 200B-16DO, ET 200B-16DO/2A

Characteristic	DP Keyword to EN 50170, Part 3	16DI	32DI	32DI 0.2ms	16DO	16DO/2A
Manufacturer ID	Ident_Number	0001 _H	0004 _H	000C _H	0002 _H	0005 _H
Supports 9.6 kbaud	9.6_supp	Yes				
Supports 19.2 kbaud	19.2_supp	Yes				
Supports 93.75 kbaud	93.75_supp	Yes				
Supports 187.5 kbaud	187.5_supp	Yes				
Supports 500 kbaud	500_supp	Yes				
Supports 1.5 Mbaud	1.5M_supp	Yes				
Supports 3 Mbaud	3M_supp	Yes				
Supports 6 Mbaud	6M_supp	Yes				
Supports 12 Mbaud	12M_supp	Yes				
Supports FREEZE control command	Freeze_Mode_supp	Yes	Yes	Yes	–	–
Supports SYNC control command	Sync_Mode_supp	–	–	–	Yes	Yes
Supports autobaud search	Auto_Baud_supp	Yes				
Software-settable station number	Set_Slave_Add_supp	No				
Length of user-specific data (parameterization telegram)	User_Prm_Data_Len	5 Byte				
User-specific data (parameterization telegram)	User_Prm_Data	00 _H , 00 _H , 00 _H , 00 _H , 00 _H				
Modular station	Modular_Station	No				

A

**32DO, 8RO,
8DI/8DO and
8DI/8DO HWA**

The table below lists the master data of the ET 200B modules: 32DO, 8RO, 8DI/8DO and 8DI/8DO HWA.

Table A-4 Characteristics according to EN 50170, Part 3 for ET 200B-32DO, ET 200B-8RO, ET 200B-8DI/8DO, ET 200B-8DI/8DO HWA

Characteristic	DP Keyword to EN 50170, Part 3	32DO	8RO	8DI/8DO	8DI/8DO HWA
Manufacturer ID	Ident_Number	000D _H	0003 _H	000B _H	0010 _H
Supports 9.6 kbaud	9.6_supp	Yes			
Supports 19.2 kbaud	19.2_supp	Yes			
Supports 93.75 kbaud	93.75_supp	Yes			
Supports 187.5 kbaud	187.5_supp	Yes			
Supports 500 kbaud	500_supp	Yes			
Supports 1.5 Mbaud	1.5M_supp	Yes			
Supports 3 Mbaud	3M_supp	Yes			
Supports 6 Mbaud	6M_supp	Yes			
Supports 12 Mbaud	12M_supp	Yes			
Supports FREEZE control command	Freeze_Mode_supp	–	–	Yes	Yes
Supports SYNC control command	Sync_Mode_supp	Yes	Yes	Yes	Yes
Supports autobaud search	Auto_Baud_supp	Yes			
Software-settable station number	Set_Slave_Add_supp	No			
Length of user-specific data (parameterization telegram)	User_Prm_Data_Len	5 Byte			
User-specific data (parameterization telegram)	User_Prm_Data	00 _H , 00 _H , 00 _H , 00 _H , 00 _H			
Modular station	Modular_Station	No			

**16DI/16DO,
24DI/8DO and
24DI/8DO 0.2ms**

The table below lists the master data of the ET 200B modules: 16DI/16DO, 24DI/8DO and 24DI/8DO 0.2 ms.

Table A-5 Characteristics according to EN 50170, Part 3 for ET 200B-16DI/16DO, ET 200B-24DI/8DO, ET 200B-24DI/8DO 0.2ms

Characteristic	DP Keyword to EN 50170, Part 3	16DI/16DO	24DI/8DO	24DI/8DO 0.2ms
Manufacturer ID	Ident_Number	000A _H	000F _H	000E _H
Supports 9.6 kbaud	9.6_supp	Yes		
Supports 19.2 kbaud	19.2_supp	Yes		
Supports 93.75 kbaud	93.75_supp	Yes		
Supports 187.5 kbaud	187.5_supp	Yes		
Supports 500 kbaud	500_supp	Yes		
Supports 1.5 Mbaud	1.5M_supp	Yes		
Supports 3 Mbaud	3M_supp	Yes		
Supports 6 Mbaud	6M_supp	Yes		
Supports 12 Mbaud	12M_supp	Yes		
Supports FREEZE control command	Freeze_Mode_supp	Yes	Yes	Yes
Supports SYNC control command	Sync_Mode_supp	Yes	Yes	Yes
Supports autobaud search	Auto_Baud_supp	Yes		
Software-settable station number	Set_Slave_Add_supp	No		
Length of user-specific data (parameterization telegram)	User_Prm_Data_Len	5 Byte		
User-specific data (parameterization telegram)	User_Prm_Data	00 _H , 00 _H , 00 _H , 00 _H , 00 _H		
Modular station	Modular_Station	No		

A

16DI-AC, 16DO-AC, 16RO-AC and 8DI/8RO-AC The table below lists the master data of the ET 200B modules: 16DI-AC, 16DO-AC, 16RO-AC and 8DI/8RO-AC.

Table A-6 Characteristics according to EN 50170, Part 3 for ET 200B-16DI-AC, ET 200B-16DO-AC, ET 200B-16RO-AC, ET 200B-8DI/8RO-AC

Characteristic	DP Keyword to EN 50170, Part 3	16DI-AC	16DO-AC	16RO-AC	8DI/8RO-AC
Manufacturer ID	Ident_Number	0019 _H	001A _H	001C _H	001D _H
Supports 9.6 kbaud	9.6_supp	Yes			
Supports 19.2 kbaud	19.2_supp	Yes			
Supports 93.75 kbaud	93.75_supp	Yes			
Supports 187.5 kbaud	187.5_supp	Yes			
Supports 500 kbaud	500_supp	Yes			
Supports 1.5 Mbaud	1.5M_supp	Yes			
Supports 3 Mbaud	3M_supp	Yes			
Supports 6 Mbaud	6M_supp	Yes			
Supports 12 Mbaud	12M_supp	Yes			
Supports FREEZE control command	Freeze_Mode_supp	Yes	–	–	Yes
Supports SYNC control command	Sync_Mode_supp	–	Yes	Yes	Yes
Supports autobaud search	Auto_Baud_supp	Yes			
Software-settable station number	Set_Slave_Add_supp	No			
Length of user-specific data (parameterization telegram)	User_Prm_Data_Len	5 Byte			
User-specific data (parameterization telegram)	User_Prm_Data	00 _H , 00 _H , 00 _H , 00 _H , 00 _H			
Modular station	Modular_Station	No			

4/8AI, 4AI and 4AO The table below lists the master data of the ET 200B modules: 4/8AI, 4AI and 4AO.

Table A-7 Characteristics according to EN 50170, Part 3 for ET 200B-4/8AI, ET 200B-4AI, ET 200B-4AO

Characteristic	DP Keyword to EN 50170, Part 3	4/8AI	4AI	4AO
Manufacturer ID	Ident_Number	801A _H	8019 _H	8018 _H
Supports 9.6 kbaud	9.6_supp	Yes		
Supports 19.2 kbaud	19.2_supp	Yes		
Supports 93.75 kbaud	93.75_supp	Yes		
Supports 187.5 kbaud	187.5_supp	Yes		
Supports 500 kbaud	500_supp	Yes		
Supports 1.5 Mbaud	1.5M_supp	Yes		
Supports 3 Mbaud	3M_supp	Yes		
Supports 6 Mbaud	6M_supp	Yes		
Supports 12 Mbaud	12M_supp	Yes		
Supports FREEZE control command	Freeze_Mode_supp	Yes	Yes	–
Supports SYNC control command	Sync_Mode_supp	–	–	Yes
Supports autobaud search	Auto_Baud_supp	Yes		
Software-settable station number	Set_Slave_Add_supp	No		
Length of user-specific data (parameterization telegram)	User_Prm_Data_Len	see Appendix C		
User-specific data (parameterization telegram)	User_Prm_Data	see Appendix C		
Modular station	Modular_Station	No		

Configuration Telegram

B

Applicability

If you use configuration software such as COM ET 200 or STEP 7, you can ignore this chapter.

In this Chapter

If you address ET 200B modules via a configuration telegram for example with CP 5431 as DP master, you can consult this chapter for details of how to structure the configuration telegram for the various types of ET 200B module.

Structure for Digital Modules

The configuration telegram for digital modules consists of 2 bytes.

The structure of the configuration telegram for digital ET 200B modules is as follows:

Table B-1 Structure of the Configuration Telegram for Digital ET 200B Modules

Slot	Byte n
Slot 1 - Output area of the digital module (byte 0)	See Table B-2
Slot 2 - Input area of the digital module (byte 1)	

IDs for Digital ET 200B

Table B-2 contains all IDs (hexadecimal) for the digital ET 200B modules.

Table B-2 IDs for Digital ET 200B Modules

Digital Module	Order Number	ID		Consistency	Address Scope (Bytes)		Address Area
		Byte 0 Slot 0	Byte 1 Slot 1		O	I	
ET 200B-16DI	6ES7 131-0BH00-0XB0	00	11	Byte	-	2	digital
ET 200B-32DI	6ES7 131-0BL00-0XB0	00	13	Byte	-	4	digital
ET 200B-32DI 0.2ms	6ES7 131-0BL10-0XB0						
ET 200B-16DO	6ES7 132-0BH00-0XB0	21	00	Byte	2	-	digital
ET 200B-16DO/2A	6ES7 132-0BH10-0XB0	21	00	Byte	2	-	digital
ET 200B-32DO	6ES7 132-0BL00-0XB0	23	00	Byte	4	-	digital
ET 200B-8DI/8DO	6ES7 133-0BH00-0XB0	20	10	Byte	1	1	digital
ET 200B-8DI/8DO HWA	6ES7 133-0BH10-0XB0	21	10	Byte	2	1	digital
ET 200B-16DI/16DO	6ES7 133-0BL00-0XB0	21	11	Byte	2	2	digital
ET 200B-24DI/8DO	6ES7 133-0BN00-0XB0	20	12	Byte	1	3	digital
ET 200B-24DI/8DO 0.2ms	6ES7 133-0BN10-0XB0						
ET 200B-8RO	6ES7 132-0GF00-0XB0	20	00	Byte	1	-	digital
ET 200B-16DI-AC	6ES7 131-0HF00-0XB0	00	11	Byte	-	2	digital
ET 200B-16DO-AC	6ES7 132-0HF00-0XB0	21	00	Byte	2	-	digital
ET 200B-16RO-AC	6ES7 132-0HH00-0XB0	21	00	Byte	2	-	digital
ET 200B-8DI/8RO-AC	6ES7 133-0HH00-0XB0	20	10	Byte	1	1	digital

Structure for Analog Modules

The length of the configuration telegram for analog modules depends on the type of configuration.

The structure of the configuration telegrams for analog ET 200B modules is as follows:

Table B-3 Structure of the Configuration Telegram for Analog ET 200B Modules

Slot	Byte				
	n	n + 1	n + 2	n + 3	n + 4
Slot 1 (virtual only) (n = 0)	04	00	00	AD	C4
Slot 2 (virtual only) (n = 5)	04	00	00	9B	40
Slot 3 (virtual only) (n = 10)	04	00	00	8F	C0
Slots 4 to 11 – input and output areas of the analog module (n = 15, n = 20, ... n = 50)	See Table B-4				

IDs for Analog ET 200B

Table B-4 contains all IDs (hexadecimal) for the analog ET 200B modules

Table B-4 IDs for Analog ET 200B Modules

Analog Module (Order No.: 6ES7 ...)	Slot	Byte ¹				
		n	n + 1	n + 2	n + 3	n + 4
ET 200B-4/8AI	Configuration for entire module (8AI):					
	4	43	47	00	15	C5
	Configuration by channels (1 × AI to 8 × AI):					
	4	43	40	00	15	C2
ET 200B-4AI	5 to 11	43	40	00	95	C2
	Configuration for entire module (4AI):					
	4	43	43	00	15	C4
	Configuration by channels (1 × AI to 4 × AI):					
ET 200B-4AO	4	43	40	00	15	C2
	5 to 7	43	40	00	95	C2
	Configuration for entire module (4AO):					
	4	83	43	00	25	D0
ET 200B-4AO	Configuration by channels (1 × AO to 4 × AO):					
	4	83	40	00	25	D0
	5 to 7	83	40	00	A5	D0

¹ n = 15: slot 4 ... n = 50: slot 11

B

Example of a Configuration Telegram

You want to configure an ET 200B-4AO with two output channels (channels 0 and 1).

The configuration telegram consists of 25 bytes, as follows:

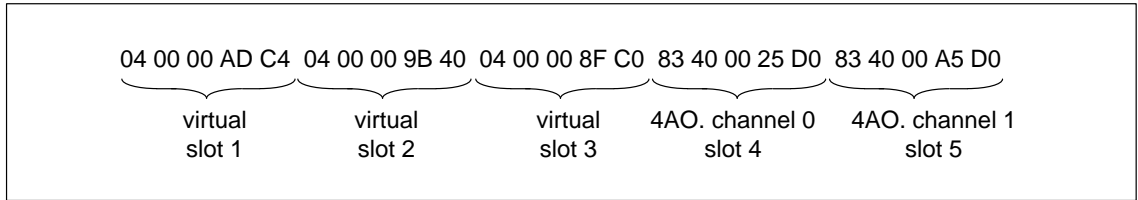

Parameterization Telegram

C

Applicability

If you use configuration software such as COM ET 200 or STEP 7, you can ignore this chapter.

In this Chapter

If you parameterize ET 200B modules via a parameterization telegram for example with CP 5431 as DP master, you can consult this chapter for details of how to structure the parameterization telegram for the various types of ET 200B module.

Section	Describes	Page
C.1	Structure of the parameterization telegram	C-2
C.2	Standard part of the parameterization telegram	C-3
C.3	Parameters for status	C-4
C.4	Parameters for analog input modules	C-5
C.5	Parameters for analog output module	C-10

C.1 Structure of the Parameterization Telegram

Definition: Parameterization Telegram

All the parameterizable values of the ET 200B are stored in the parameterization telegram.

Structure for Digital Modules

No settings can be made for digital ET 200B modules via the parameterization telegram. 5 bytes must contain "00_H" by default.

The structure of the parameterization telegrams for digital ET 200B modules is as follows:

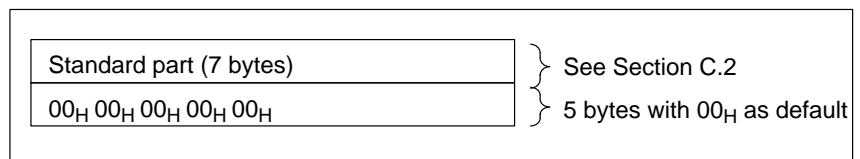

Figure C-1 Structure of the Parameterization Telegram for Digital ET 200B modules

Structure for Analog Modules

In the case of analog ET 200B modules, you can use the parameterization telegram to define diagnostics response and set the defaults for analog value measurement or analog value output, as applicable.

Structure of the parameterization telegram for analog ET 200B modules is as follows:

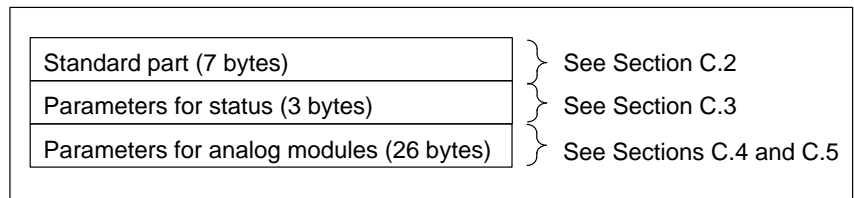

Figure C-2 Structure of the Parameterization Telegram for Analog ET 200B Modules

C.2 Standard Part of the Parameterization Telegram

Standard Part

The first 7 bytes of the parameterization telegram are standardized to EN 50170, Part 3, and their contents could be as follows:

Byte 0	08 _H	Station status
Byte 1	01 _H	Watchdog factor 1
Byte 2	06 _H	Watchdog factor 2
Byte 3	0B _H	Response delay T _{RDY}
Byte 4	80 _H	Manufacturer ID, high byte;
Byte 5	1D _H	Manufacturer ID, low byte
Byte 6	00 _H	Group ID

Figure C-3 Standard Part of the Parameterization Telegram

C.3 Parameters for Status

Parameters for Status

The next 3 bytes contain the status bytes. The meanings of the parameters are described in Figure C-4.

The defaults for these three bytes are:

- 00_H 60_H 0D_H: for 4/8AI and 4AI
- 00_H 20_H 0D_H: for 4AO

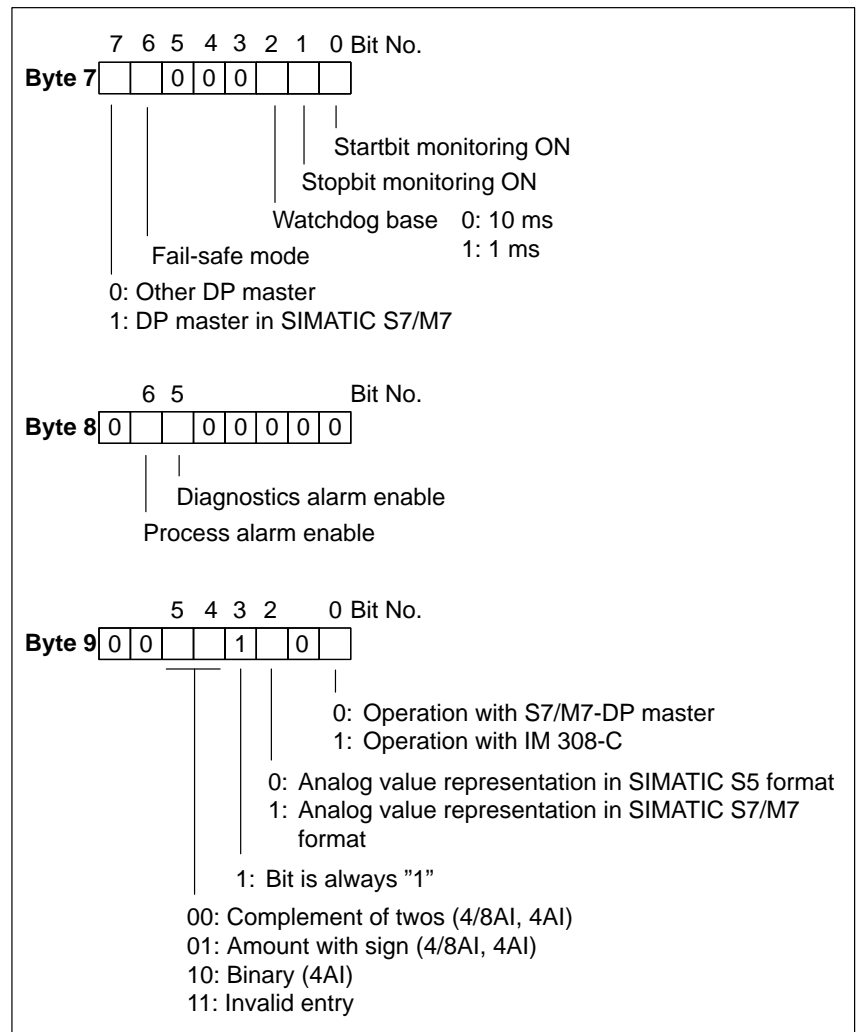

Figure C-4 Parameters for Status

C.4 Parameters for Analog Input Modules

Parameters for 4/8AI and 4AI

The next bytes (bytes 10 to 35) contain the following parameters for ET 200B-4/8AI and ET 200B-4AI:

Byte 10	07 _H	Block length	} For bytes 15, 16
Byte 11	5F _H	S7 constant	
Byte 12	04 _H	Slot	
Byte 13	00 _H	Data record number	
Byte 14	02 _H	Data record length	
Byte 15		Diagnostics enable	} See Figure C-6
Byte 16		Wire break monitor enable	
Byte 17	13 _H	Block length	} For bytes 22 to 35
Byte 18	5F _H	S7 constant	
Byte 19	04 _H	Slot	
Byte 20	01 _H	Data record number	
Byte 21	0E _H	Data record length	
Bytes 22 to 35		Parameters for analog value measurement	} See Figure C-7

Figure C-5 Parameters for Analog Input Modules 4/8AI, 4AI

Channel (Group)

The parameters listed on the following pages refer to channel groups for ET 200B-4/8AI and to channels for ET 200B-4AI. Table C-1 shows the assignment of terminals to channels and channel groups.

Table C-1 Assignment of Terminals to Channel (Groups)

Channel (Group) n	4/8AI	4AI
Channel (group) 0	Channel group 0 (terminals 0.1/0.2, 0.3/0.4)	Channel 0 (terminals 0.1/0.2)
Channel (group) 1	Channel group 1 (terminals 1.1/1.2, 1.3/1.4)	Channel 1 (terminals 1.1/1.2)
Channel (group) 2	Channel group 2 (terminals 2.1/2.2, 2.3/2.4)	Channel 2 (terminals 2.1/2.2)
Channel (group) 3	Channel group 3 (terminals 3.1/3.2, 3.3/3.4)	Channel 3 (terminals 3.1/3.2)

C

Bytes 15, 16

Figure C-6 shows the contents of bytes 15 and 16. You activate a parameter by setting the corresponding bit to "1".

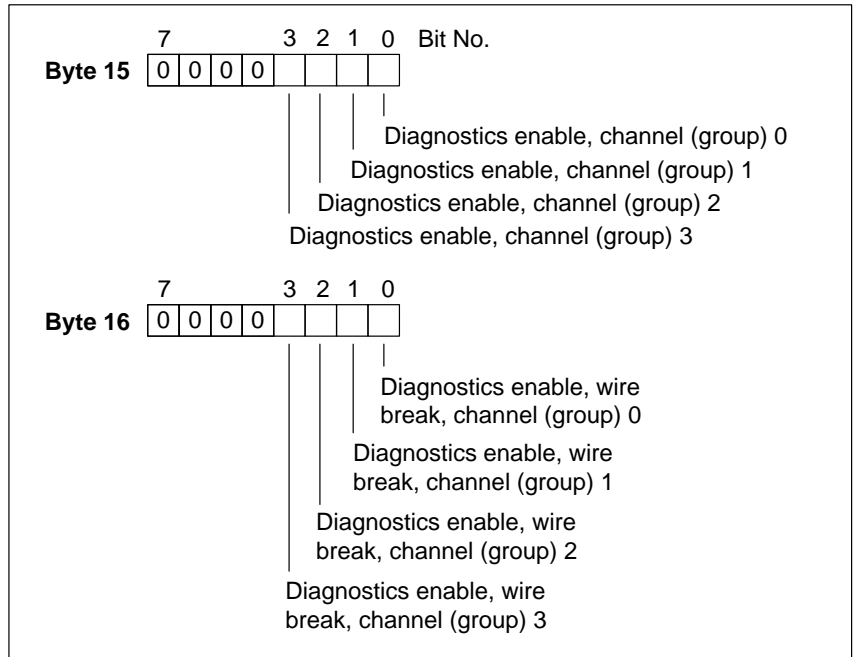

Figure C-6 Bytes 15 and 16 for Analog Input Modules 4/8AI, 4AI

Bytes 22 to 35

Figure C-7 shows the structure of bytes 22 to 35. You activate a parameter by setting the corresponding bit to "1".

Note

Representation of the limit values corresponds to analog value representation. Always bear the limit ranges in mind when setting the limit values.

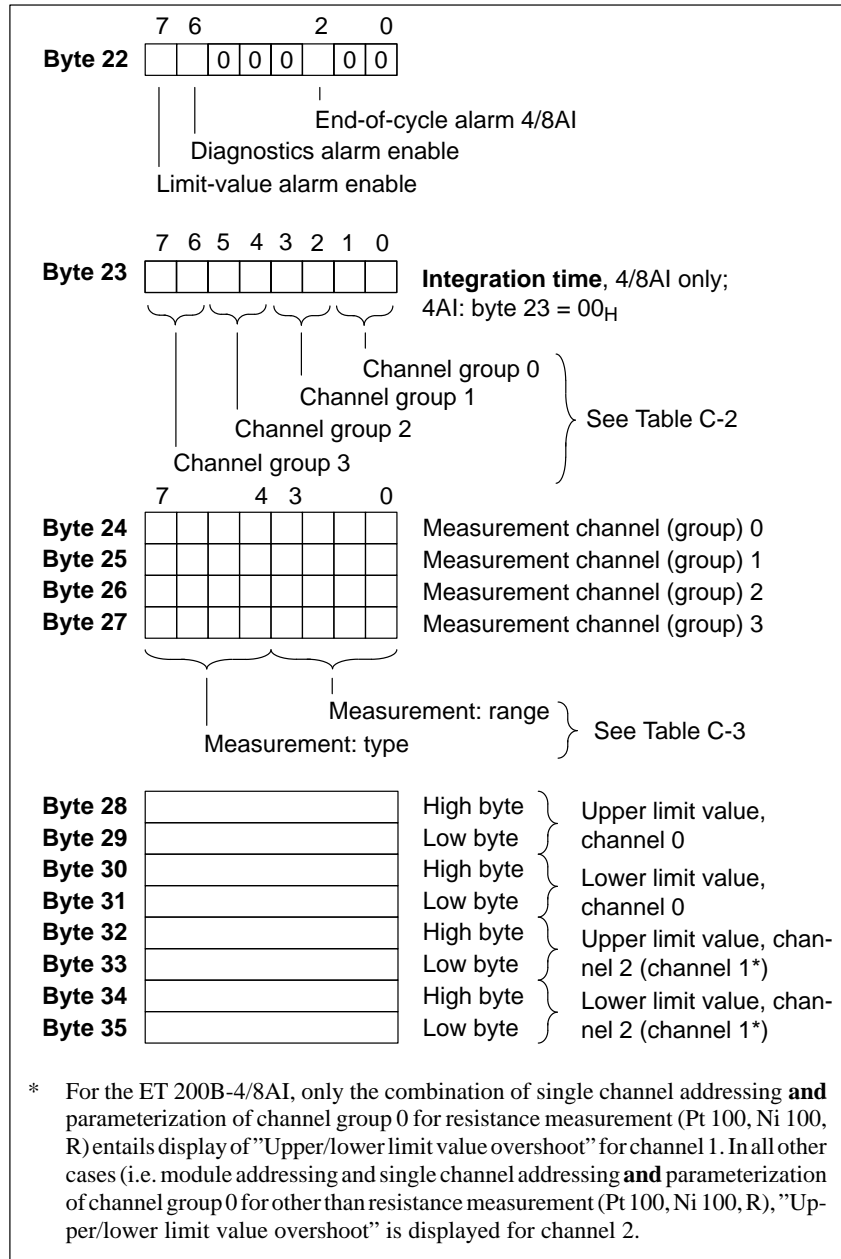

Figure C-7 Bytes 22 and 35 for Analog Input Modules 4/8AI, 4AI



Integration Time

Table C-2 contains the codings for the various integration times that you can set per channel group in byte 23 for the 4/8AI (see Figure C-7).

Table C-2 Codings for the Integration Times of the 4/8AI

Integration Time	Coding
2.5 ms	2#00
16.7 ms	2#01
20 ms	2#10
100 ms	2#11

Type of Measurement and Measuring Ranges

Table C-3 lists all measuring ranges of the analog input modules. The table shows the codings for the type of measurement plus the codings for the corresponding measuring ranges. You must enter the codings for the desired measuring range in bytes 24 to 27 (see Figure C-7).

Table C-3 Codings for the Measuring Ranges of the Analog Input Modules

Measurement: Type	Coding (Bits 4 to 7)	Measuring Range ¹	Coding (Bits 0 to 3)
Deactivated	2#0000	Deactivated	2#0000
Voltage	2#0001	± 80 mV (4/8AI)	2#0001
		± 250 mV (4/8AI)	2#0010
		± 500 mV (4/8AI)	2#0011
		± 1 V (4/8AI)	2#0100
		± 2.5 V (4AI)	2#0101
		± 5 V (4AI)	2#0110
		± 1.25 V (4AI)	2#0100
		± 10 V (4AI)	2#1001
Current	2#0010	0 ... 20 mA (4AI)	2#0010
		4 ... 20 mA (4AI)	2#0011
		± 20 mA (4AI)	2#0100
Resistance	2#0100	48 Ω (4/8AI)	2#0001
		150 Ω (4/8AI)	2#0010
		300 Ω (4/8AI)	2#0100
		600 Ω (4/8AI)	2#0110
Thermal resistance + linearization	2#1000	Pt 100 standard range (4/8AI)	2#0010
		Ni 100 standard range (4/8AI)	2#0011

Table C-3 Codings for the Measuring Ranges of the Analog Input Modules, continued

Measurement: Type	Coding (Bits 4 to 7)	Measuring Range ¹	Coding (Bits 0 to 3)
Thermal elements with linearization	2#1110	Type N [NiCrSi – NiSi] (4/8AI)	2#0001
		Type E [NiCr – CuNi] (4/8AI)	2#0010
		Type J [Fe – CuNi IEC] (4/8AI)	2#0101
		Type L [Fe – CuNi DIN] (4/8AI)	2#0110
		Type T [Cu – CuNi IEC] (4/8AI)	2#0111
		Type K [NiCr – Ni] (4/8AI)	2#1000
		Type U [Cu – CuNi DIN] (4/8AI)	2#1001

¹ The measuring ranges apply only to the modules in parentheses.

C.5 Parameters for Analog Output Module

Parameters for 4AO

The next bytes (bytes 10 to 35) contain the following parameters for ET 200B-4AO:

Byte 10	07 _H	Block length	} For bytes 15, 16
Byte 11	5F _H	S7 constant	
Byte 12	04 _H	Slot	
Byte 13	00 _H	Data record number	
Byte 14	02 _H	Data record length	
Byte 15		Diagnostics enable	} See Figure C-9
Byte 16		Reserved	
Byte 17	13 _H	Block length	} For bytes 22 to 35
Byte 18	5F _H	S7 constant	
Byte 19	04 _H	Slot	
Byte 20	01 _H	Data record number	
Byte 21	0E _H	Data record length	
Byte 22 to 35	⋮	Parameters for analog value output	} See Figure C-10

Figure C-8 Parameters for Analog Output Module 4AO

Channel

In the tables on the next pages, the parameters for ET 200B-4AO apply to channels. Table C-4 shows the assignment of terminals to channels

Table C-4 Assignment of Terminals to Channels

Channel n	Terminals on 4AO
Channel 0	Terminals 0.1/0.2
Channel 1	Terminals 1.1/1.2
Channel 2	Terminals 2.1/2.2
Channel 3	Terminals 3.1/3.2

Bytes 22 to 35

Figure C-10 shows the structure of bytes 22 to 35. You activate a parameter by setting the corresponding bit to "1".

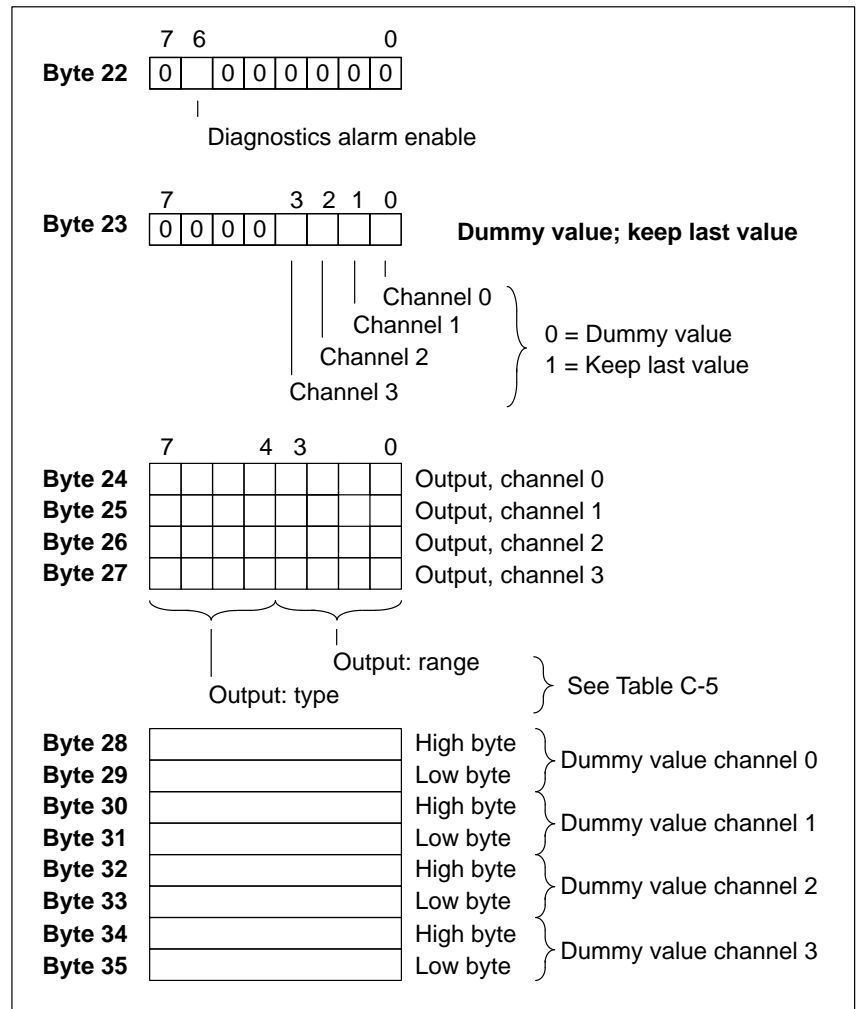

Figure C-10 Bytes 22 to 35 for Analog Output Module 4AO

Note

Representation of the dummy values corresponds to analog value representation. Bear the applicable range limits in mind when setting the dummy values.

Type of Output and Output Ranges

Table C-5 lists all output ranges of the analog output module. The table shows the codings for the type of output plus the codings for the corresponding output ranges. You must enter the codings for the desired output range in bytes 24 to 27 (see Figure C-10).

Table C-5 Codings for Output Ranges of the Analog Output Module

Output: Type	Coding (Bits 4 to 7)	Output Range	Coding (Bits 0 to 3)
Deactivated	2#0000	Deactivated	2#0000
Voltage	2#0001	0 to 10 V \pm 10 V	2#1000 2#1001
Current	2#0010	0 to 20 mA 4 to 20 mA \pm 20 mA	2#0010 2#0011 2#0100

Configuring with COM ET 200 V4.x

D

Introduction

You do not need the information in this chapter unless you want to replace old ET 200B modules that you configured with **COM ET 200 V4.x** with the new ET 200B modules (order numbers: see Appendix F) described in this manual.

Compatibility

You can easily replace old ET 200B modules with the new ET 200B modules without having to reconfigure and parameterize the modules.

You can also configure the new ET 200B modules with the type files under COM ET 200 V4.x.

When used in conjunction with the IM 308-B and COM ET 200 V 4.x, the new modules behave like the old ET 200B modules they replace with regard to configuration and diagnostics.

Type Files

The names of the type files needed for COM ET 200 V4.x are listed in Appendix A.1. (see also Table 4-1)

In this Chapter

In case you do not have access to the previous edition of this manual, the most important information for configuring with COM ET 200 V 4.x is summarized below.

In Section	you will find	on Page
D.1	Status and error indication by LEDs	D-2
D.2	Slave diagnostics	D-3
D.3	Configuration options	D-11
D.4	Setting the operating mode with COM ET 200 V4.x	D-12

If information on these topics would be redundant, you will find a reference to the corresponding section of the manual on COM ET 200 Windows.

Additional Information

The manual *ET 200 Distributed I/O System* (Order No.: 6ES5 998-3ES.1) contains detailed information on how to use COM ET 200 V4.x.

D.1 Status and Error Indication by LEDs

Error Indication, Digital ET 200B See Table 5-1, Section 5.2.

Error Indication, Analog ET 200B The table below explains the meanings of the signals provided by the LEDs on analog ET 200B modules for configuration with COM ET 200 V4.x.

Table D-1 LEDs on Analog ET 200B Modules and their Meanings

LED RUN	LED BF	LED DIA	Meaning	Remedy
Off	Off	Off	Voltage not applied to module.	<ul style="list-style-type: none"> Check the power supply. Check that the electronics block is correctly mounted on the terminal block.
Lit (green)	Off	Off	Module is on the PROFIBUS-DP and is exchanging data.	-
Lit (green)	Lit (red) or off	Lit (red)	An error has occurred on the module (e.g. parameterization incorrect, wire break, measuring range overshoot)	<ul style="list-style-type: none"> Read the diagnostics buffer to identify the error, see Sections 5.3 and D.2 If there is no diagnostics information in the buffer, check parameterization to ascertain whether the diagnostics alarm and corresponding channel diagnostics have been enabled.
Lit (green)	Flashing (red)	Off	Either <ul style="list-style-type: none"> Module has not received a parameterization telegram, or telegram is incorrect. or <ul style="list-style-type: none"> Incorrect bus protocol or <ul style="list-style-type: none"> Module has received incorrect configuration data. 	<ul style="list-style-type: none"> Check the configuration in the DP master (station number, station type). Check the configuration.
Lit (green)	Flashing (red)	Lit (red)	Module has received incorrect parameterization or configuration telegram.	Check parameterization and configuration.
Lit (green)	Flashes once (red)	Off	Module is powering up.	-
Lit (green)	Lit (red)	No significance	Baud rate matching in progress.	<ul style="list-style-type: none"> Check the PROFIBUS-DP connection. Check the DP master.

D.2 Slave Diagnostics

In this Section

This section contains information on slave diagnostics of ET 200B in operation with IM 308-B.

Section	Describes	Page
D.2.1	General information on slave diagnostics, operation with IM 308-B	D-4
D.2.2	Structure of slave diagnostics	D-6
D.2.3	Structure of device-related diagnostics (analog ET 200B)	D-8

D.2.1 General Information on Slave Diagnostics, Operation with IM 308-B

Requesting Slave Diagnostics

Diagnostics are loaded word by word in the STEP5 application program and transferred to the diagnostics word. (The load and transfer operations always refer in the following to the default diagnostics address 252).

In the case of page addressing, the diagnostics word is on the "basic page". Before requesting diagnostics in the case of page addressing, you must first "switch" to the basic page.

Basic Structure of the STEP 5 Listing for Diagnostics:

STL	Explanation
L KB (basic page number)	Page selection
T PY 255	(basic page number: nx16, n=0,1,..)
L KY (station number),(code)	Load diagnostics (station number: 3...99, code: → Table D-2 and D-3) and transfer to the diagnostics word (diagnostics word: here PW 252).
T PW 252	
L PW 252	Evaluate diagnostics word (hex-code: → Section D.2.2)
L KH (hex-code: no error)	Error?
!=F	
BEC	
JC FBx	Evaluate error in FBx.

More Information

Handling a request for slave diagnostics corresponds to general access to diagnostics data for the IM 308-B and is described in detail in the manual *ET 200 Distributed I/O System* (Order No. 6ES5 998-3ES.1).

The following is an example of how to request slave diagnostics with the STEP5 application program and place the data in the diagnostics word.

Example: Requesting Diagnostics

This example shows how to request station status 1 and 2.
Program the following in STEP 5:

STL	Explanation
L KY n,0 T PW 252	Store in the "Diagnostics address" byte the number of the slave station (n = station number) from which the station status is to be requested; store the code for "station status 1 and station status 2" (code = 0) in the "Diagnostics address +1" byte.
L PW 252 L KH 000C !=F BEC JC FBx	Load the diagnostics word Response monitoring activated No error? Evaluate error in FBx.

D.2.2 Structure of Slave Diagnostics

Introduction 16 bytes per slave are reserved for slave diagnostics. These 16 bytes are organized in 8 words.

The 2 diagnostics bytes of the diagnostics word are referred to below as the "Diagnostics address" and "Diagnostics address +1".

Digital ET 200B The table below shows the structure of slave diagnostics for digital ET 200B modules:

Table D-2 Structure of Slave Diagnostics for Digital ET 200B, Operation with IM 308-B

Code	Diagnostics address	Diagnostics address +1
0	Station status 1 (byte 0)	Station status 2 (byte 1)
1	Station status 3 (byte 2)	Master station number (byte 3)
2	Manufacturer ID (high) (byte 4)	Manufacturer ID (low) (byte 5)
3	Header (byte 6) (device-related diagnostics)	Device-related diagnostics (byte 7) (group diagnostics)
4	Free	Free
5	Free	Free
6	Free	Free
7	Free	Free

More Information, Digital ET 200B You will find the information you need on slave diagnostics for digital ET 200B modules in the following sections.

You will find	on Section
General information on slave diagnostics, operation with IM 308-B	D.2.1
Structure of station status 1 to 3	5.3.4
Structure of the master station number and manufacturer ID	5.3.5
Structure of device-related diagnostics (digital ET 200B)	5.3.6

Analog ET 200B

The table below shows the structure of slave diagnostics for analog ET 200B modules:

Table D-3 Structure of Slave Diagnostics for Analog ET 200B, Operation with IM 308-B

Code	Diagnostics address	Diagnostics address +1
0	Station status 1 (byte 0)	Station status 2 (byte 1)
1	Station status 3 (byte 2)	Master station number (byte 3)
2	Manufacturer ID (high) (byte 4)	Manufacturer ID (low) (byte 5)
3	Header (byte 6) (device-related diagnostics)	Device-related diagnostics (byte 7) (reserved)
4	Device-related diagnostics (byte 8) (reserved)	Device-related diagnostics (byte 9) (type of error)
5	Device-related diagnostics (byte 10) (always: 15 _H)	Device-related diagnostics (byte 11) (wrong station type)
6	Device-related diagnostics (byte 12) (EPROM or ADC/DAC error)	Device-related diagnostics (byte 13) (channel type)
7	Device-related diagnostics (byte 14) (always: 08 _H)	Device-related diagnostics (byte 15) (number of channels)

**More Information,
Analog ET 200B**

You will find the information you need on slave diagnostics for analog ET 200B modules in the following sections.

you will find	in Section
General information on slave diagnostics, operation with IM 308-B	D.2.1
Structure of station status 1 to 3	5.3.4
Structure of the master station number and manufacturer ID	5.3.5
Structure of device-related diagnostics (analog ET 200B)	D.2.3

D.2.3 Structure of Device-Related Diagnostics (Analog ET 200B)

Introduction

The structure of device-related diagnostics for configuring the analog modules with COM ET 200 V4.x is described below.

In essence, this section is comparable with Section 5.3.8 of this manual.

No ID-related diagnostics are displayed in operation with COM ET 200 V4.x.

Diagnostics Alarm, Process Alarm

Analog modules configured with COM ET 200 V4.x do not support alarms (diagnostics alarm, process alarm).

Device-Related Diagnostics

The device-related diagnostics for an analog ET 200B shows you the error reported by the ET 200B. The header indicates the length of device-related diagnostics.

Note

Chapter 8 contains a discussion of "Supplementary Bits" in the section dealing with analog value representation: these bits contain additional diagnostics information.

Header (Byte 6)

The analog ET 200B modules contain the following information in the "Header (device-related diagnostics)" byte.

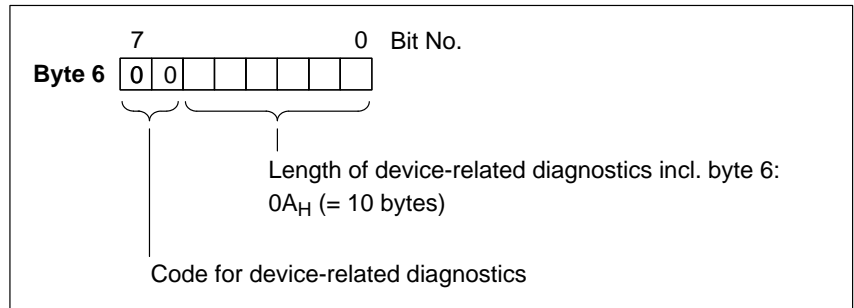

Figure D-1 Structure of the Header (Device-Related Diagnostics) for Analog ET200B

Device-Related Diagnostics

Device-related diagnostics of the analog ET 200B modules comprises 9 bytes:

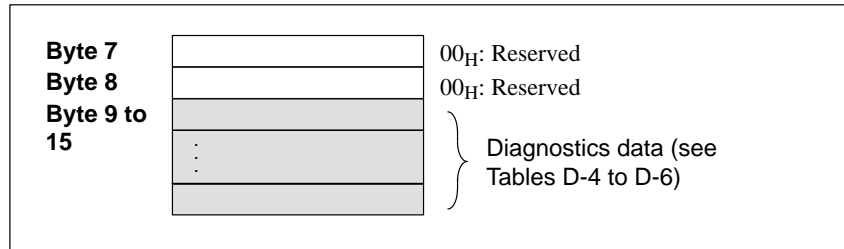

Figure D-2 Structure of Device-Related Diagnostics for Analog ET 200B (Bytes 7 to 15)

Bytes 9 to 12

Table D-4 shows the structure and contents of bytes 9 to 12.

Table D-4 Diagnostics Data, Bytes 9 to 12

Byte	Bit	Meaning		Byte	Bit	Meaning
9 (→ Tab. D-5)	0	Diagnostics message waiting		11	0	Wrong ET 200B station type
	1	Internal error			1	Reserved
	2	External error, e.g. wire break			2	Reserved
	3	Channel error			3	Reserved
	4	Reserved			4	Reserved
	5	Reserved			5	Reserved
	6	Reserved			6	Reserved
	7	Incorrect parameters in module			7	Reserved
10	0 to 3	Module class	0101 Analog module	12	0	Reserved
	4	Channel information waiting			1	Reserved
	5	Reserved			2	EPROM error (4AI)
	6	Reserved			3	Reserved
	7	Reserved			4	ADC/DAC error (4AO)
					5	Reserved
					6	Reserved
					7	Reserved

Possible Values, Byte 9 The possible values for byte 9 are as follows:

Table D-5 Possible Values for Byte 9

Value	Bit 3	Bit 2	Bit 1	Bit 0	Meaning
00 _H	0	0	0	0	No error
03 _H (83 _H)	0	0	1	1	Internal error, no channel error; (incorrect parameters in the module)
0B _H (8B _H)	1	0	1	1	Internal error, channel error; (incorrect parameters in the module)
0D _H	1	1	0	1	External error, channel error
0F _H (8F _H)	1	1	1	1	Summation error of all the above errors; (incorrect parameters in the module)

Bytes 13 to 15 Table D-6 shows the structure and contents of bytes 13 to 15.

Table D-6 Diagnostics Data, Bytes 13 to 15

Byte	Bit	Meaning	Remark	
13	0 to 7	Channel type	71 _H 73 _H	4/8AI, 4AI 4AO
14	0 to 7	Number of diagnostics bits output per channel by a module.	08 _H	4/8AI, 4AI, 4AO
15	0 to 7	Number of channels of a module.	04 _H 08 _H	4AI, 4AO 4/8AI

D.3 Configuration Options

IDs Table D-7 shows the possible IDs for configuring the ET 200B modules with COM ET 200 V4.x. The following address IDs are possible for ET 200B:

Table D-7 IDs for ET 200B

Module	Order Number	Address ID		Consistency	Address Scope (Bytes)		Address Area
		Slot 0	Slot 1		O	I	
ET 200B-16DI	6ES7 131-0BH00-0XB0	000	017	Byte	–	2	digital
ET 200B-32DI	6ES7 131-0BL00-0XB0	000	019	Byte	–	4	digital
ET 200B-32DI 0.2ms	6ES7 131-0BL10-0XB0						
ET 200B-16DO	6ES7 132-0BH01-0XB0	033	000	Byte	2	–	digital
ET 200B-16DO/2A	6ES7 132-0BH11-0XB0	033	000	Byte	2	–	digital
ET 200B-32DO	6ES7 132-0BL01-0XB0	035	000	Byte	4	–	digital
ET 200B-8DI/8DO	6ES7 133-0BH01-0XB0	8DA or 032	8DE or 016	Byte	1	1	digital
ET 200B-8DI/8DO HWA	6ES7 133-0BH10-0XB0	033	8DE or 016	Byte	1	1	digital
ET 200B-16DI/16DO	6ES7 132-0BL00-0XB0	033	017	Byte	2	–	digital
ET 200B-24DI/8DO	6ES7 133-0BN01-0XB0	8DA or 032	018	Byte	1	3	digital
ET 200B-24DI/8DO 0.2ms	6ES7 133-0BN11-0XB0						
ET 200B-8RO	6ES7 132-0GF00-0XB0	032	000	Byte	1	–	digital
ET 200B-16DI-AC	6ES7 131-0HF00-0XB0	000	017	Byte	–	2	digital
ET 200B-16DO-AC	6ES7 132-0HF00-0XB0	033	000	Byte	2	–	digital
ET 200B-16RO-AC	6ES7 132-0HH00-0XB0	033	000	Byte	2	–	digital
ET 200B-8DI/8RO-AC	6ES7 133-0HH00-0XB0	8DA or 032	8DE or 016	Byte	1	1	digital
ET 200B-4/8AI	6ES7 134-0KH01-0XB0	087	–	Word	–	16	analog
ET 200B-4AI	6ES7 134-0HF01-0XB0	4AE or 083	–	Word	–	8	analog
ET 200B-4AO	6ES7 135-0HF01-0XB0	099	–	Word	8	–	analog

D.4 Setting the Operating Mode with COM ET 200 V4.x

Introduction

The structure of the parameterization telegram for configuring with COM ET 200 V4.x is described below.

Structure for Digital Modules

In the case of digital ET 200B modules, no settings can be made by means of the parameterization telegram. When you open the "DP Slave Parameterization Telegram" dialog box, 5 bytes are assigned "00_H" by default.

Note

In the case of digital ET 200B modules, **do not** overwrite the 5 bytes which default to "00_H" in the parameterization telegram.

Structure for Analog Modules

In the case of analog ET 200B modules, you can use the parameterization telegram to define diagnostics response and set the defaults for analog value measurement or analog value output, as applicable.

When parameterizing with COM ET 200 V4.x you enter only the user-specific part of the parameterization telegram (without standard part) in the KH format ("DP Slave Parameterization Telegram" dialog box).

Defaults and Structure of the Parameterization Telegram

When you open the "DP Slave Parameterization Telegram" dialog box for the first time, the parameterization telegram is structured and contains certain defaults, as shown below.

- For ET 200B-4/8AI:

DP SLAVE PARAMETERIZATION TELEGRAM										
Byte	(input in KH format)									
0	13	00	00	00	00	00	AA	14	14	14
10	14	00	00	00	00	00	00	00	00	06
20	FF	00	00	00	00					

- For ET 200B-4AI:

DP SLAVE PARAMETERIZATION TELEGRAM										
Byte	(input in KH format)									
0	13	00	00	00	00	00	00	19	19	19
10	19	00	00	00	00	00	00	00	00	06
20	FF	00	00	00	00					

- For ET 200B-4AO:

DP SLAVE PARAMETERIZATION TELEGRAM										
Byte (input in KH format)										
0	13	00	00	00	00	00	00	19	19	19
10	19	00	00	00	00	00	00	00	00	06
20	FF	00	00	00	00					

Note

As regards parameterization of the functions of the analog modules, only the bytes with borders "□" in the Figures are of relevance.

All other bytes contain "00_H" or COM ET 200 V4.x-specific codes that you **must** leave unchanged.

Parameters for Analog Modules

The meanings of the bytes with borders "□" in the figures above are as follows:

Table D-8 Content and Meanings of the Bytes in the Parameterization Telegram

Byte	Breakdown	Code	
3	Diagnostics message enable per channel (group).		
	Bit 0 = channel (group) 0 Bit 1 = channel (group) 1 Bit 2 = channel (group) 2 Bit 3 = channel (group) 3	Bit is "1": Diagnostics message enabled Bit is "0": Diagnostics message disabled (default)	
4	Wire break monitor enable, only ET 200B-4/8AI with selected value range Pt 100, thermocouple or voltage sensor ± 80 mV		
	Bit 0 = channel group 0 Bit 1 = channel group 1 Bit 2 = channel group 2 Bit 3 = channel group 3	Bit is "1": Diagnostics message enabled Bit is "0": Diagnostics message disabled (default) (If wire break occurs, the overflow bit is also set.)	4/8AI
6	Setting for integration time, ET 200B-4/8AI only		
		AA _H 55 _H	Integration time 20 ms for 50 Hz supply (default) Integration time 16.7 ms for 60 Hz supply



Table D-8 Content and Meanings of the Bytes in the Parameterization Telegram, continued

Byte	Breakdown	Code		
7, 8, 9, 10	Setting for analog value range			
	Byte 7 = channel (group) 0	19 _H	± 10 V (default)	4AI, 4AO
	Byte 8 = channel (group) 1	18 _H	0 ... 10 V	4AO
	Byte 9 = channel (group) 2	16 _H	± 5 V	4AI
	Byte 10 = channel (group) 3	15 _H	± 2.5 V	4AI
		14 _H	± 1.25 V, for ET 200B-4AI	4AI
		14 _H	± 1 V, for ET 200B-4/8AI (default)	4/8AI
		13 _H	± 0.5 V	4/8AI
		12 _H	± 0.25 V	4/8AI
		11 _H	± 80 mV	4/8AI
		24 _H	± 20 mA	4AI, 4AO
	22 _H	0 ... 20 mA	4AI, 4AO	
	23 _H	4 ... 20 mA	4AI, 4AO	
82 _H	Pt 100 Standard	4/8AI		
E5 _H	Thermocouple Type J with linearization	4/8AI		
E8 _H	Thermocouple Type K with linearization	4/8AI		
E6 _H	Thermocouple Type L with linearization	4/8AI		
23	Selection for measured-value representation (ET 200B-4AI and ET 200B-4/8AI only)			
		00 _H	Complement of twos	4AI, 4/8AI
		01 _H	Amount and sign	4AI, 4/8AI
		02 _H	Binary	4AI

Analog Modules and Old Type Files

Introduction

You do not need the information in this chapter unless you want to replace old analog modules that you configured with the type file **SIxxxxAE.200** under COM ET 200 Windows with the new analog modules (order numbers: see Appendix F) described in this manual.

If you use the type file **SIxxxxBE.200** for configuring under COM ET 200 Windows, you can ignore this chapter (see also Table 4-1).

Compatibility

You can easily replace old analog modules with the new analog modules without having to reconfigure and parameterize the modules.

You can also configure the new analog modules with the type file **SIxxxxAE.200** under COM ET 200 Windows.

When configured with **SIxxxxAE.200**, the new modules behave like the old analog modules they replace with regard to configuration and diagnostics.

Type Files

The names of the type files needed for COM ET 200 Windows are listed in Appendix A.1.

In this Chapter

The two type-file versions **SIxxxxAE.200** and **SIxxxxBE.200** evince differences with regard to configuration, parameterization and diagnostics information.

In case you do not have access to the previous edition of this manual, the points in which the newer version of the type file differs from the **SIxxxxAE.200** are described below.

In Section	you will find	on Page
E.1	Status and error indication by LEDs	E-2
E.2	Structure of device-related diagnostics (analog ET 200B)	E-3
E.3	Configuration options	E-7
E.4	Parameters for the analog modules	E-8

E.1 Status and Error Indication by LEDs

Introduction The table below explains the error indications for analog ET 200B modules for configuration with the type file **SIxxxxAE.200**.

Error Indication, Analog ET 200B The table below explains the meanings of the signals provided by the LEDs on analog ET 200B modules.

Table E-1 LEDs on Analog ET 200B Modules and their Meanings

LED RUN	LED BF	LED DIA	Meaning	Remedy
Off	Off	Off	Voltage not applied to module.	<ul style="list-style-type: none"> Check the power supply. Check that the electronics block is correctly mounted on the terminal block.
Lit (green)	Off	Off	Module is on the PROFIBUS-DP and is exchanging data.	-
Lit (green)	Lit (red) or off	Lit (red)	An error has occurred on the module (e.g. wire break, measuring range overshoot)	<ul style="list-style-type: none"> Read the diagnostics buffer to identify the error, see Sections 5.3 and E.2 If there is no diagnostics information in the buffer, check parameterization to ascertain whether the diagnostics alarm and corresponding channel diagnostics have been enabled.
Lit (green)	Flashing (red)	Off	Either <ul style="list-style-type: none"> Module has not received a parameterization telegram, or telegram is incorrect. or <ul style="list-style-type: none"> Incorrect bus protocol or <ul style="list-style-type: none"> Module has received incorrect configuration data. 	<ul style="list-style-type: none"> Check the configuration in the DP master (station number, station type). Check the configuration.
Lit (green)	Flashing (red)	Lit (red)	Module has received incorrect parameterization or configuration data.	Check parameterization and configuration
Lit (green)	Flashes once (red)	Off	Module is powering up.	-
Lit (green)	Lit (red)	No significance	Baud rate matching in progress.	<ul style="list-style-type: none"> Check the PROFIBUS-DP connection. Check the DP master.

E.2 Structure of Device-Related Diagnostics (Analog ET 200B)

Introduction

The structure of device-related diagnostics for configuring the analog modules with the type file **SIxxxxAE.200** is described below.

In essence, this section is comparable with Section 5.3.8 of this manual. All other information on slave diagnostics with the IM 308-C applies as described in Section 5 above.

No ID-related diagnostics are displayed for configuration with SIxxxxAE.200.

Diagnostics Alarm, Process Alarm

Analog modules configured with SIxxxxAE.200 do not support alarms (diagnostics alarm, process alarm).

Device-Related Diagnostics

The device-related diagnostics for an analog ET 200B shows you the error reported by the ET 200B. The header indicates the length of device-related diagnostics. (see Figure 5-2)

Note

Chapter 8 contains a discussion of "Supplementary Bits" in the section dealing with analog value representation: these bits contain additional diagnostics information.

Header (Byte 6)

The analog ET 200B modules contain the following information in the "Header (device-related diagnostics)" byte.

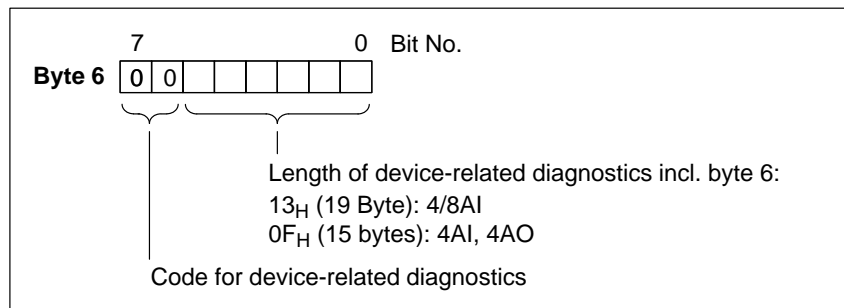

Figure E-1 Structure of the Header (Device-Related Diagnostics) for Analog ET200B

Device-Related Diagnostics

Device-related diagnostics of the analog ET 200B modules comprises a maximum of 18 bytes:

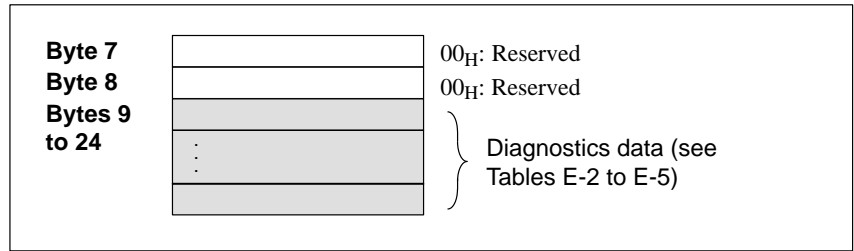

Figure E-2 Structure of Device-Related Diagnostics for Analog ET 200B (Bytes 7 to 24)

Bytes 9 to 12

Table E-2 shows the structure and contents of bytes 9 to 12.

Table E-2 Diagnostics Data, Bytes 9 to 12

Byte	Bit	Meaning		Byte	Bit	Meaning
9 (→ Tab. E-3)	0	Diagnostics message waiting		11	0	Wrong ET 200B station type
	1	Internal error			1	Reserved
	2	External error, e.g. wire break			2	Reserved
	3	Channel error			3	Reserved
	4	Reserved			4	Reserved
	5	Reserved			5	Reserved
	6	Reserved			6	Reserved
	7	Incorrect parameters in module			7	Reserved
10	0 to 3	Module class	0101 Analog module	12	0	Reserved
	4	Channel information waiting			1	Reserved
	5	Reserved			2	EPROM error (4AI)
	6	Reserved			3	Reserved
	7	Reserved			4	ADC/DAC error (4AO)
		Reserved			5	Reserved
		Reserved			6	Reserved
		Reserved			7	Reserved

Possible Values, Byte 9 The possible values for byte 9 are as follows:

Table E-3 Possible Values for Byte 9

Value	Bit 3	Bit 2	Bit 1	Bit 0	Meaning
00 _H	0	0	0	0	No error
03 _H (83 _H)	0	0	1	1	Internal error, no channel error; (incorrect parameters in the module)
0B _H (8B _H)	1	0	1	1	Internal error, channel error; (incorrect parameters in the module)
0D _H	1	1	0	1	External error, channel error
0F _H (8F _H)	1	1	1	1	Summation error of all the above errors; (incorrect parameters in the module)

Bytes 13 to 16 Table E-4 shows the structure and contents of bytes 13 to 16.

Table E-4 Bytes 13 to 16 for Diagnostics Alarm

Byte	Bit	Meaning	Remark	
13	0 to 7	Channel type	71 _H 73 _H	4/8AI, 4AI 4AO
14	0 to 7	Number of diagnostics bits output per channel by a module.	08 _H	4/8AI, 4AI, 4AO
15	0 to 7	Number of channels of a module.	04 _H 08 _H	4AI, 4AO 4/8AI
16	Channel error vector:			
	0	Channel error, channel 0	4/8AI, 4AI, 4AO	
	1	Channel error, channel 1	4/8AI, 4AI, 4AO	
	2	Channel error, channel 2	4/8AI, 4AI, 4AO	
	3	Channel error, channel 3	4/8AI, 4AI, 4AO	
	4	Channel error, channel 4	4/8AI	
	5	Channel error, channel 5	4/8AI	
	6	Channel error, channel 6	4/8AI	
7	Channel error, channel 7	4/8AI		
17 to 24 ¹	-	Channel-specific errors	see Table E-5	

¹ The number of bytes depends on the number of channels in the module.

Analog Channel

Table E-5 shows the assignment of the diagnostics byte for an analog input or analog output channel.

Table E-5 Diagnostics Byte for an Analog Input/Analog Output Channel

Byte	Bit	Analog Input Channel (4/8AI, 4AI)	Analog Output Channel (4AO)
as of 17	0	Configuration/parameterization error	
	1	Common-mode error (4/8AI only)	"0" (Reserved)
	2	"0" (Reserved)	
	3	"0" (Reserved)	Ground short-circuit
	4	Wire-break/feed-current monitoring: measuring transducer/Pt 100 ¹	
	5	"0" (Reserved)	"0" (Reserved)
	6	Measuring range undershoot	"0" (Reserved)
	7	Measuring range overshoot	"0" (Reserved)

¹ In the case of the ET 200B-4/8AI, a "wire break" error is superimposed on common-mode and measuring-range errors occurring at the same time (common-mode and measuring-range errors are not signaled).

E.3 Configuration Options

Type File The information in this section applies to the type file **SIxxxxAE.200**.

IDs Table E-6 shows the possible IDs for configuring analog modules with COM ET 200 Windows.

Single channel addressing is not possible with the type file SIxxxxAE.200.

Table E-6 Possible IDs for Configuring Input and Output and Areas

Module	Order Number	Slot 0	Length	Format	Meaning
ET 200B-4/8AI	6ES7 134-0KH01-0XB0	8AI	8	Word	All channels are transferred. ¹
ET 200B-4AI	6ES7 134-0HF01-0XB0	4AI	4	Word	All channels are transferred. ¹
ET 200B-4AO	6ES7 135-0HF01-0XB0	4AO	4	Word	All channels are transferred. ¹

¹ The address assigned is the start address for the entire module

E.4 Parameters for Analog Modules

Parameters for ET 200B-4/8AI

Table 8-9 shows all the parameters for parameterizing the ET 200B-4/8AI with COM ET 200 Windows.

You can set these parameters for the ET 200B-4/8AI if you use the type file **SI801AAE.200**.

Table E-7 Parameters for ET 200B-4/8AI (6ES7 134-0KH01-0XB0)

Parameter	Explanation	Value Range
Diagnostics enable for channel group 0 (channels 0, 1)	Diagnostics messages enabled separately for each channel group: only for thermocouples, resistance thermometers (Pt 100, Ni 100) and voltage sensors ± 80 mV	Disable
Diagnostics enable for channel group 1 (channels 2, 3)		Enable
Diagnostics enable for channel group 2 (channels 4, 5)		
Diagnostics enable for channel group 3 (channels 6, 7)		
Wire break monitoring enable for channel group 0 (channels 0, 1)	Wire break monitoring enabled separately for each channel group	Disable
Wire break monitoring enable for channel group 1 (channels 2, 3)		Enable
Wire break monitoring enable for channel group 2 (channels 4, 5)		
Wire break monitoring enable for channel group 3 (channels 6, 7)		
Integration time for module	Enter an optimum integration time for the A/D converter to help suppress noise voltage.	16.7 ms 20 ms
Measurement type and range for channel group 0 (channels 0, 1)	You can set the measurement type and range separately for each channel group For voltage measurement: For resistance thermometer with linearization: For thermocouple with external reference junction:	± 1 V
Measurement type and range for channel group 1 (channels 2, 3)		± 0.5 V
Measurement type and range for channel group 2 (channels 4, 5)		± 0.25 V
Measurement type and range for channel group 3 (channels 6, 7)		± 80 mV
		Pt 100 standard range
		Type J with linearization Type L with linearization Type K with linearization
Representation of measured values	Sets representation of the measured values for module	SIMATIC S5 SIMATIC S7
Measured value representation	Sets data format for analog value representation, SIMATIC S5	Complement of twos Amount with sign

■ : Default

Parameters for ET 200B-4AI

Table 8-40 shows all the parameters for parameterizing the ET 200B-4AI with COM ET 200 Windows.

You can set these parameters for the ET 200B-4AI if you use the type file **SI8019AE.200**.

Table E-8 Parameters for ET 200B-4AI (6ES7 134-0HF01-0XB0)

Parameter	Explanation	Value Range
Diagnosics enable for channel 0	Diagnosics messages enabled separately for each channel	Disable
Diagnosics enable for channel 1		Enable
Diagnosics enable for channel 2		
Diagnosics enable for channel 3		
Wire break monitoring enable for channel 0	Wire break monitoring enabled separately for each channel for measuring range 4 ... 20 mA	Disable
Wire break monitoring enable for channel 1		Enable
Wire break monitoring enable for channel 2		
Wire break monitoring enable for channel 3		
Measurement type and range for channel 0	You can set the measurement type and range separately for each channel For voltage measurement: For current measurement:	Channel not activated
Measurement type and range for channel 1		± 10 V ± 5 V ± 2.5 V ± 1.25 V
Measurement type and range for channel 2		
Measurement type and range for channel 3		± 20 mA 0 ... 20 mA 4 ... 20 mA
Representation of measured values	Sets representation of the analog measured values for module	SIMATIC S5 SIMATIC S7
Measured value representation	Sets data format for analog value representation, SIMATIC S5	Complement of twos Amount with sign Binary

■ : Default

Parameters for ET 200B-4AO

Table 8-58 shows all the parameters for parameterizing the ET 200B-4AO with COM ET 200 Windows.

You can set these parameters for the ET 200B-4AO if you use the type file **SI8018AE.200**.

Table E-9 Parameters for ET 200B-4AO (6ES7 135-0HF01-0XB0)

Parameter	Explanation	Explanation
Diagnostics enable for channel 0	Diagnostics messages enabled separately for each channel	Disable
Diagnostics enable for channel 1		Enable
Diagnostics enable for channel 2		
Diagnostics enable for channel 3		
Output type and range for channel 0	Type and range of output defined separately for each channel	± 10 V 0 ... 10 V ± 20 mA 0 ... 20 mA 4 ... 20 mA
Output type and range for channel 1	For voltage output:	
Output type and range for channel 2	For current output:	
Output type and range for channel 3		
Representation of output values	Sets representation of the analog values for module	SIMATIC S5 SIMATIC S7

■ : Default

F

Order Numbers

Introduction

If you require additional components for your ET 200B system or want to expand your PROFIBUS-DP, you will find the order numbers of the components you need in this chapter.

In this Chapter

The components are listed in two groups:

- ET 200B components
- Accessories for PROFIBUS-DP; the entries are accompanied by references to the various manuals for the PROFIBUS-DP master and configuration software.

Section	Describes	Page
F.1	Order numbers for ET 200B components	F-2
F.2	Order numbers for PROFIBUS-DP accessories	F-4

F.1 Order Numbers for ET 200B Components

Electronic Blocks The following types of electronics block are available:

Table F-1 Order Numbers, Electronics Blocks for ET 200B

Electronics Block	Order Number	Description
ET 200B-16DI	6ES7 131-0BH00-0XB0	Inputs: 16 × DC 24 V (3 ms)
ET 200B-32DI	6ES7 131-0BL00-0XB0	Inputs: 32 × DC 24 V (3 ms)
ET 200B-32DI 0.2ms	6ES7 131-0BL10-0XB0	Inputs: 32 × DC 24 V (0.2 ms)
ET 200B-16DO	6ES7 132-0BH01-0XB0	Outputs: 16 × DC 24 V (0.5 A/2 A)
ET 200B-16DO/2A	6ES7 132-0BH11-0XB0	Outputs: 16 × DC 24 V (2 A)
ET 200B-32DO	6ES7 132-0BL01-0XB0	Outputs: 32 × DC 24 V (0.5 A)
ET 200B-8DI/8DO	6ES7 133-0BH01-0XB0	Inputs: 8 × DC 24 V (3 ms) Outputs: 8 × DC 24 V (0.5 A)
ET 200B-8DI/8DO HWA	6ES7 133-0BH10-0XB0	Inputs: 8 × DC 24 V (3 ms) Outputs: 8 × DC 24 V (0.5 A)/hardware shut-down
ET 200B-16DI/16DO	6ES7 133-0BL00-0XB0	Inputs: 16 × DC 24 V (3 ms) Outputs: 16 × DC 24 V (0.5 A)
ET 200B-24DI/8DO	6ES7 133-0BN01-0XB0	Inputs: 24 × DC 24 V (3 ms) Outputs: 8 × DC 24 V (0.5 A)
ET 200B-24DI/8DO 0.2ms	6ES7 133-0BN11-0XB0	Inputs: 24 × DC 24 V (0.2 ms) Outputs: 8 × DC 24 V (0.5 A)
ET 200B-8RO	6ES7 132-0GF00-0XB0	Outputs: 8 × REL. DC 24 ... 60 V
ET 200B-16DI-AC	6ES7 131-0HF00-0XB0	Inputs: 16 × AC 120/230 V
ET 200B-16DO-AC	6ES7 132-0HF00-0XB0	Outputs: 16 × AC 120/230 V (0.5 A)
ET 200B-16RO-AC	6ES7 132-0HH00-0XB0	Outputs: 16 × REL. AC 120 V/DC 24 ... 150 V
ET 200B-8DI/8RO-AC	6ES7 133-0HH00-0XB0	Inputs: 8 × AC 120/230 V Outputs: 8 × REL. AC 120 V/DC 24 ... 150 V
ET 200B-4/8AI	6ES7 134-0KH01-0XB0	8 analog differential inputs or 4 x Pt 100 (measuring principle: integrating)
ET 200B-4AI	6ES7 134-0HF01-0XB0	4 analog differential inputs (Measuring principle: successive approximation)
ET 200B-4AO	6ES7 135-0HF01-0XB0	4 analog outputs

Terminal Blocks The following types of terminal block are available:

Table F-2 Order Numbers, Terminal Blocks for ET 200B

Terminal Block	Order Number	Description
TB1/DC	6ES7 193-0CA10-0XA0	16 channels, screw terminals, 3 tiers
TB1-4/DC	6ES7 193-0CA20-0XA0	16 channels, screw terminals, 4 tiers
TB2/DC	6ES7 193-0CB10-0XA0	32 channels, screw terminals, 3 tiers
TB2-4/DC	6ES7 193-0CB20-0XA0	32 channels, screw terminals, 4 tiers
TB3/DC	6ES7 193-0CA30-0XA0	16 channels, spring-latching terminals
TB4/DC	6ES7 193-0CB30-0XA0	32 channels, spring-latching terminals
TB4M/DC	6ES7 193-0CE30-0XA0	32 channels, spring-latching terminals with 4th terminal tier for extra ground connections
TB6/AC	6ES7 193-0CC10-0XA0	16 channels, screw terminals, 3 tiers
TB8-analog	6ES7 193-0CD40-0XA0	4-/8 channels, spring-latching terminals

Labeling Strips You can order additional sets of labeling strips under the following order numbers:

Table F-3 Order Numbers, Labeling Strips

Labeling Strips for	Set of	Order Number
16DI, 16DO, 8DI/8DO, 8DI/8DO HWA	10	6ES7 193-0BB00-0XA0
32DI, 32DI 0.2ms 32DO, 16DI/16DO, 24DI/8DO, 24DI/8DO 0.2ms	7	6ES7 193-0BD00-0XA0
8RO	10	6ES7 193-0BA00-0XA0
16DO/2A	7	6ES7 193-0BC00-0XA0
16DI-AC, 16DO-AC, 16RO-AC, 8DI/8RO	7	6ES7 193-0BF00-0XA0
4/8AI, 4AI, 4AO	10	6ES7 193-0BE00-0XA0

F.2 Order Numbers for PROFIBUS-DP Accessories

Introduction

This section contains a list of the order numbers for the PROFIBUS-DP accessories you need for ET 200B.

It also contains lists of the various manuals that you may need, depending on the PROFIBUS-DP master in use.

Network Components for ET 200

Table F-4 shows all the network components for the ET 200 distributed I/O system that you may need in conjunction with ET 200B.

Table F-4 Accessories for the ET 200 Distributed I/O System

Accessory	Order Number
RS 485 repeater, PROFIBUS-DP, IP 20	6ES7 972-0AA00-0XA0
Bus connectors	
• without programmer adapter (max. 12 MB)	6ES7 972-0BA10-0XA0
• with programmer adapter (max. 12 MB)	6ES7 972-0BB10-0XA0
• without programmer adapter, without terminating resistor (max. 1.5 MB)	6ES7 972-0BA30-0XA0
Bus cables	
• Normal	6XV1 830-0AH10
• Drum	6XV1 830-3BH10
• Underground	6XV1 830-3AH10
Repeater adapters	6GK1 510-1AA00
Optical link modules for fiber-optic waveguides	6GK1 502-3AB00 6GK1 502-4AB00
PROFIBUS-DP dropline	6ES7 901-4BD00-0XA0

Manuals for ET 200 in SIMATIC S5 In order to program and start up an ET 200B with COM ET 200, you will need one of the manuals listed in Table F-5.

Table F-5 Manuals for ET 200 in SIMATIC S5

Manual	Contents
ET 200 Distributed I/O System (6ES5 988-3ES.1)	<ul style="list-style-type: none"> • Description of the IM 308-B master interface for S5-115U, S5-135U and S5-155U • Use of COM ET 200 V4.x
ET 200 Distributed I/O System (6ES5 988-3ES.2)	<ul style="list-style-type: none"> • Description of the IM 308-C master interface for S5-115U, S5-135U and S5-155U • Description of the S5-95U with PROFIBUS-DP master interface • Use of COM ET 200 Windows • Working with the FB IM308C

Manuals for STEP 7 and SIMATIC S7 In order to program and start up an ET 200B with STEP 7, you require the manuals listed in Table F-6.

To order manuals with 6ES7 order numbers: see Catalog ST 70

Table F-6 Manuals for STEP 7 and SIMATIC S7

Manual	Contents
S7-300 Programmable Controller Hardware and Installation	Topics including <ul style="list-style-type: none"> • Description of the PROFIBUS-DP interface of the CPU 315-2 DP • Structuring the PROFIBUS-DP network • Bus connectors and RS 485 repeaters
M7-300 Programmable Controller Hardware and Installation	Topics including <ul style="list-style-type: none"> • Description of the PROFIBUS-DP interfaces in M7-300 • Structuring the PROFIBUS-DP network • Bus connectors and RS 485 repeaters
S7-400, M7-400 Programmable Controllers Module Specification	Topics including <ul style="list-style-type: none"> • Description of the PROFIBUS-DP interfaces in S7-400 and M7-400 • Structuring a PROFIBUS-DP network • Bus connectors and RS 485 repeaters
System Software for S7-300 and S7-400 Program Design Programming Manual	Topics including description of addressing and diagnostics in SIMATIC S7
System Software for S7-300 and S7-400 System and Standard Functions Reference Manual	Description of the SFCs in STEP 7

Glossary

B

Baud rate Data transmission rate; specifies the number of bits transferred per second (baud rate = bit rate).

ET 200 supports baud rates from 9.6 kbaud to 12 Mbaud.

Bus Common transmission path connecting all stations; has two defined ends.
In ET 200 the bus is a two-wire cable or a waveguide.

Bus connector Physical connection between bus station and bus cable.
ET 200 has bus connectors with and without adapter for programming device/PC and having IP 20 and IP 65 protection ratings.

Bus segment → Segment

Bus station Device which can send or receive data via the bus or amplify this data, e.g. DP master, DP slave, RS 485 repeater, active star coupler.

C

Chassis ground The entire range of interconnected inactive parts of a device that are not subject to any dangerous touch voltages even in the event of a fault.

Coding plug You set the input/output circuit of analog modules by means of the coding plugs.

Coding slide switch The setting of the coding slide switch on the → terminal block determines which → electronics block can be connected.

Configuring	Assigning addresses for the inputs/outputs of a slave station.
Control command	<p>A DP master can send commands simultaneously to a group of slaves to synchronize the slave stations.</p> <p>Event-driven synchronization of slave stations is possible using the control commands → FREEZE and → SYNC.</p>
CP 5410 S5-DOS/ST	Programming device interface for connection to SINEC L2 and to SINEC L2-DP. The CP 5410 S5-DOS/ST can be plugged into only the PG 730, 740, 750 and 770 programming devices.
D	
Device-related diagnostics	The highest level of slave-specific diagnostics. Device-related diagnostics refers to the entire slave.
Diagnostics	<p>The detection, pinpointing, classification and further evaluation of errors, faults, malfunctions and signals.</p> <p>Diagnostics provides monitoring functions which run automatically while the system is in operation. This enhances plant availability by reducing setup times and outages.</p> <p>ET 200 supports a number of diagnostics options ranging from an overview of the DO slaves which have reported diagnostics down to monitoring of individual channels.</p>
Diagnostics alarm	<p>Modules having diagnostics capability report systems to the central CPU by means of diagnostics alarms.</p> <p>In SIMATIC S7/M7: When an error is detected or disappears (e.g. wire break), the module triggers a diagnostics alarm if alarms are enabled. The CPU interrupts processing of the application program or lower priority classes and processes the diagnostics alarm block (OB 82).</p> <p>In SIMATIC S5: The diagnostics alarm is mapped within device-related diagnostics. Errors such as wire break, etc. are detected by regularly querying the diagnostics bits of device-related diagnostics.</p>

Distributed I/O station	<p>An input/output device used not in the central device but installed at a considerable distance from the CPU. Distributed I/O stations include:</p> <ul style="list-style-type: none"> • ET 200M, ET 200B, ET 200C, ET 200U • DP/AS-I Link • S5-95U with PROFIBUS-DP slave interface • Other DP slaves from Siemens or other vendors <p>The distributed I/O stations connect to the DP master via the PROFIBUS-DP bus.</p>
DP master	<p>A → master which behaves in accordance with standard EN 50170, Part 3 is known as a DP master.</p>
DP slave	<p>A → slave which operates on the PROFIBUS with the PROFIBUS-DP protocol and which behaves in accordance with standard EN 50170, Part 3, is a DP slave.</p>
E	
Electronics block	<p>Upper section of the ET 200B distributed I/O station. The electronics block contains the logic and plugs into the → terminal block.</p>
ET 200	<p>The ET 200 distributed I/O system with the PROFIBUS-DP protocol is a bus for connecting distributed I/O to a CPU or an adequate DP master. ET 200 is characterized by fast reaction times since only small amounts of data (bytes) are transferred on the bus.</p> <p>ET 200 is based on the PROFIBUS standard EN 50170, Part 1, and the PROFIBUS-DP standard, EN 50170, Part 3.</p> <p>ET 200 operates on the master/slave principle. DP masters can be, for example, the IM 308-C master interface module or the CPU 315-2 DP.</p> <p>DP slaves can be the ET 200B, ET 200C, ET 200M, ET 200U distributed I/O stations or Siemens DP slaves or other-vendor devices.</p>
F	
Floating	<p>The reference potentials of control and load circuits are galvanically isolated in the case of floating I/O modules; this is achieved, for example, by means of optocouplers, relay contacts or line transformers. Input and output circuits may be grouped.</p>

Floating-ground measurement

Each signal line has its own signal reference line.

Floating-ground measurement is required,

- if the sensors are connected to different potentials and
- if different signal sources are physically apart.

FREEZE

A →control command issued by the DP master to a group of DP slaves.

When it receives the FREEZE control command, the DP slave freezes the current status of the **inputs** and transmits this information cyclically to the DP master.

Every time it receives a FREEZE control command, the DP slave re-freezes the status of its **inputs**.

The input data is not again cyclically transmitted by the DP slave to the DP master until the DP master sends the UNFREEZE control command.

G

Ground-referenced measurement

All signal reference lines are run to a common → reference potential.

GSD file

Device master data file; file in which the slave-specific characteristics such as number of inputs or outputs, number of diagnostics bits, SYNC-capability, etc. are defined. There is a GSD file for every Siemens DP standard slave.

You need this file only if you want to connect a DP standard slave to a DP master that is not a Siemens product. If you are using a Siemens DP master you do not need a GSD file. The device master data for Siemens DP masters is defined in the → type file (COM ET 200-specific format).

I

IP 20

Degree of protection to DIN 40050: protection against touch with the fingers and ingress of foreign bodies having a diameter larger than 12mm.

M

Master

When in possession of the token, the master can send data to other stations and request data from other stations (= active stations).

→ DP masters include, for example the CPU 315-2 DP and the IM 308-C.

Master interface module Module for distributed configuration. The distributed I/O "connects" to the PLC via the IM 308-C master interface module.

Master/slave method Bus access method in which only one station is the → DP master and all other stations are → DP slaves.

N

Non-floating The reference potentials of control and load circuits are electrically connected in the case of non-floating I/O modules.

P

Parameterization master Each DP slave has **one** parameterization master. On startup, the parameterization master downloads the parameterization data to the DP slave. The parameterization master has read and write access to the DP slave and can change the configuration of a DP slave.

Process alarm A process alarm is triggered by S7 modules with interrupt capability in response to certain events in the process. The process alarm is reported to the central CPU. The appropriate organization block is then processed, in accordance with the priority of the interrupt.

In SIMATIC S7/M7: An operating range is defined, for example by parameterizing an upper and lower limit value. If the process signal (e.g. temperature) of an analog input module exists this range, the module triggers a process alarm if alarms are enabled. The CPU interrupts processing of the application program or lower priority classes and processes the process alarm block (OB 40).

In SIMATIC S5: The process alarm is mapped within device-related diagnostics. Errors such as upper limit-value overshoot, etc. are detected by regularly querying the diagnostics bits of device-related diagnostics.

PROFIBUS PROcess FieLd BUS, German process and field-bus standard, defined by the PROFIBUS standard (EN 50170). It specifies the functional, electrical and mechanical characteristics for a bit-serial field bus system.

PROFIBUS is a bus system which networks PROFIBUS-compatible automation systems and field devices on the cell and field levels. PROFIBUS versions support the protocols DP (= Dezentrale Peripherie, distributed I/O), FMS (= Fieldbus Message Specification) or TF (= Technological Functions).

PROFIBUS-DP PROFIBUS system supporting the DP protocol. DP stands for "dezentrale Peripherie", or distributed I/O. The ET 200 distributed I/O system is based on the PROFIBUS-DP standard (EN 50170, Part 3).

Siemens also uses the designation "SINEC L2-DP" for PROFIBUS-DP.

Protective ground conductor A conductor required as a protective measure against electric shock currents. The symbol for the protective ground conductor is PE.

R

Reference potential Potential in relation to which the voltages of the circuits concerned are considered and/or measured.

Response monitoring time A slave parameter in COM ET 200. If a slave station is not addressed within the response monitoring time, it automatically goes to the safe state, i.e. all outputs are set to "0".

S

Segment The bus cable between two terminating resistors forms a segment. A segment contains 0 ... 32 → bus stations. Segments can be linked by → repeaters.

Short-circuit A conductive connection, caused by a fault, between conductors that are live in normal operation if no load resistance is inserted in the faulty circuit.

Station number Each ET 200 bus station must be assigned a station number. The programming device is addressed at station number "0".
Masters and slaves are assigned station numbers in the range 3 ... 125. Exception: ET 200B is assigned a station number in the range 3 ... 99.

STEP 7 Programming language for generating application programs for SIMATIC S7 controllers.

SYNC A → control command issued by the master to a slave.
Using this control command, the master can freeze the outputs at the instantaneous value. The output data for the subsequent frames is stored, but the statuses of the outputs remain unchanged. The outputs are not updated until the master sends the UNSYNC control command.

SYNC

A → control command issued by the DP master to a group of DP slaves.

Using this control command, the DP master instructs the DP slave to freeze the **outputs** at the instantaneous value. In subsequent frames the slave stores the output data, but the statuses of the outputs remain unchanged.

Every time it receives a SYNC control command, the DP slave sets the outputs it had stored as output data.

The outputs are not again cyclically updated until the DP master sends the UNSYNC control command.

T**Terminal block**

The terminal block carries the hard wiring. The → electronics block plugs into the terminal block.

Terminating resistor

Resistor for matching the impedance of bus cables; terminating resistors are always required at the ends of cables or segments.

In ET 200 the terminating resistors are activated/deactivated in → bus connectors.

Type file

File required by COM ET 200 for configuring a slave station. The type file contains the definitions of the slave-specific characteristics, for example number of inputs or outputs, number of diagnostics bytes, SYNC capability, etc.

Each ET 200B station type has its own type file, which is generated by Siemens, forms a component part of COM ET 200 (version 4.1 and later) or is supplied with the manual.

W**Wire break**

A break in the lines to a sensor or a fault in the sensor itself.

Index

A

- accessories, order numbers, F-4
- ADC/DAC error, 5-20
- analog value representation SIMATIC S7
 - ET 200B-4/8AI, 8-26, 8-39
 - ET 200B-4AO, 8-87
 - ET 200B-4AI, 8-70
- analog value representation, SIMATIC S5
 - ET 200B-4/8AI, 8-26
 - ET 200B-4AO, 8-85
 - ET 200B-4AI, 8-65

B

- bus cable, order number, F-4
- bus connector, 3-26, 7-13
- bus interface, wiring, 3-26

C

- CE, certification, 6-3
- certification
 - CE, 6-3
 - FM, 6-3
 - UL/CSA, 6-3
- channel error, 5-19, 5-21
- channel information, 5-20
- channel type, 5-21
- coding plugs, 3-9, 8-23, 8-62, 8-83
- coding slide switch, 3-9
- COM ET 200 V4.x, D-1
- common-mode error, analog output module, 5-21
- conductor cross sections, 3-23
- configuration
 - grounded, 3-17
 - ungrounded, 3-20
- configuration error, analog output module, 5-21
- configuration telegram
 - analog ET 200B, B-3
 - digital ET 200B, B-2
- configuring, 4-1

- connecting loads, ET 200B-4AO, 8-78
- connecting transducers
 - ET 200B-4/8AI, 8-7
 - ET 200B-4AI, 8-53

D

- device-related diagnostics
 - analog ET 200B, 5-18
 - digital ET 200B, 5-14
- diagnostics
 - operation with IM 308-C, 5-6
 - operation with S7/M7 DP masters or other PROFIBUS-DP masters, 5-8
 - device-related diagnostics, analog, 5-18
 - device-related diagnostics, digital, 5-14
 - ID-related diagnostics, analog, 5-16
 - manufacturer ID, 5-13
 - master station number, 5-13
 - operation with IM 308-B, D-4
 - slave diagnostics, 5-5
 - station status 1 to 3, 5-11
- dismantling, 3-14

E

- electronics block, **1-3**
 - characteristics, 1-6
 - definition, 1-6
 - design, 2-4
 - installing, 3-12
- EPROM error, 5-20
- error
 - ADC/DAC, 5-20
 - EPROM, 5-20
- error diagnostics
 - by LEDs, 5-3
 - slave diagnostics, 5-5
- ET 200B, 1-3

- ET 200B-16DI
 - block diagram, 7-16
 - characteristics, 7-15
 - pin assignment, 7-18
 - technical data, 7-19
- ET 200B-16DI-AC
 - block diagram, 7-75
 - characteristics, 7-74
 - pin assignment, 7-76
 - technical data, 7-78
- ET 200B-16DI/16DO
 - block diagram, 7-63, 7-64
 - characteristics, 7-62
 - pin assignment, 7-65
 - technical data, 7-67
- ET 200B-16DO
 - block diagram, 7-27, 7-28
 - characteristics, 7-26
 - pin assignment, 7-29
 - technical data, 7-31
- ET 200B-16DO-AC
 - block diagram, 7-80
 - characteristics, 7-79
 - pin assignment, 7-81
 - technical data, 7-83
- ET 200B-16DO/2A
 - block diagram, 7-33, 7-34
 - characteristics, 7-32
 - pin assignment, 7-35
 - technical data, 7-37
- ET 200B-16RO-AC
 - block diagram, 7-85
 - characteristics, 7-84
 - pin assignment, 7-86
 - technical data, 7-88
- ET 200B-24DI/8DO, ET 200B-24DI/8DO 0.2ms
 - block diagram, 7-69, 7-70
 - characteristics, 7-68
 - pin assignment, 7-71
 - technical data, 7-73
- ET 200B-32DI, ET 200B-32DI 0.2ms
 - block diagram, 7-21, 7-22
 - characteristics, 7-20
 - pin assignment, 7-23
 - technical data, 7-25
- ET 200B-32DO
 - block diagram, 7-39, 7-40
 - characteristics, 7-38
 - pin assignment, 7-41
 - technical data, 7-43
- ET 200B-4/8AI
 - analog value representation SIMATIC S5, 8-26
 - analog value representation SIMATIC S7, 8-39
 - characteristics, 8-5
 - connecting transducers, 8-7
 - parameters, 8-24
 - possible IDs, 8-20
 - schematic circuit diagram, 8-47
 - technical data, 8-49
 - terminal assignment, 8-48
- ET 200B-4AI
 - analog value representation SIMATIC S7, 8-70
 - analog value representation, SIMATIC S5, 8-65
 - block diagram, 8-72
 - characteristics, 8-51
 - connecting transducers, 8-53
 - parameters, 8-63
 - possible IDs, 8-61
 - technical data, 8-74
 - terminal assignment, 8-73
- ET 200B-4AO
 - analog value representation SIMATIC S7, 8-87
 - analog value representation, SIMATIC S5, 8-85
 - block diagram, 8-89
 - characteristics, 8-76
 - connecting loads, 8-78
 - parameters, 8-84
 - possible IDs, 8-82
 - technical data, 8-91
 - terminal assignment, 8-90
- ET 200B-8DI/8DO
 - block diagram, 7-50, 7-51
 - characteristics, 7-49
 - pin assignment, 7-52
 - technical data, 7-54
- ET 200B-8DI/8RO-AC
 - block diagram, 7-90
 - characteristics, 7-89
 - pin assignment, 7-91
 - technical data, 7-93
- ET 200B-8RO
 - block diagram, 7-45, 7-46
 - characteristics, 7-44
 - pin assignment, 7-47
 - technical data, 7-48

ET 200B-8DI/8DO HWA
 block diagram, 7-56, 7-57
 characteristics, 7-55
 HW cutoff, 7-59
 pin assignment, 7-58
 technical data, 7-61
 external error, 5-19

F

feed-current monitoring, analog output module,
 5-21
 FM, certification, 6-3
 fuse, 3-11
 approved, 3-11
 changing, 3-11
 order numbers, 3-11

G

grounded configuration, 3-17
 GSD file, A-4

I

ID
 ET 200B-4/8AI, 8-20
 ET 200B-4AI, 8-61
 ET 200B-4AO, 8-82
 ID-related diagnostics, analog ET 200B, 5-16
 IDs, configuration telegram, B-2, B-3
 IM 308-B, D-1
 installing
 electronics block, 3-12
 terminal block, 3-2
 internal error, 5-19

L

LEDs, 2-4, 5-3
 LEDs for diagnostics, 5-3

M

M-short-circuit, analog output module, 5-21
 manufacturer ID, 5-13
 master station number, 5-13
 module class, 5-20
 module defect, 5-19

mounting
 on a standard section rail, 3-6
 with shield connecting element, 3-7, 3-8

O

order numbers, F-2

P

parameterization error, analog output module,
 5-21
 parameterization missing, 5-19
 parameterization telegram, C-2
 analog ET 200B, C-2
 digital ET 200B, C-2
 parameterizing, 4-1
 parameters
 ET 200B-4AO, 8-84
 ET 200B-4/8AI, 8-24
 ET 200B-4AI, 8-63
 incorrect in module, 5-19
 parameterization telegram, C-2
 process alarm lost, 5-20
 PROFIBUS-DP interface, 3-26
 PROFIBUS-DP dropline, order number, F-4

S

S7-slave, 1-4
 shield connecting element, 3-2, 3-5, 3-25
 shielding, 3-25
 SINEC L2-DP, 1-2
See also PROFIBUS-DP
 slave diagnostics, D-3
 operation with IM 308-B, D-4
 slave diagnostics
 operation with IM 308-C, 5-6
 operation with S7/M7 DP masters or other
 PROFIBUS-DP masters, 5-8
 definition, 5-5
 device-related diagnostics, analog, 5-18
 device-related diagnostics, digital, 5-14
 ID-related diagnostics, analog, 5-16
 manufacturer ID, 5-13
 master station number, 5-13
 requesting, 5-10
 station status 1 to 3, 5-11
 To Next, 5-5
 station number, 1-5, 3-9

station status, structure, 5-11

T

technical specifications

- ET 200B-16DI, 7-19
- ET 200B-24DI/8DO, ET 200B-24DI/8DO
0.2ms, 7-73
- ET 200B-32DI, ET 200B-32DI 0.2ms, 7-25
- ET 200B-32DO, 7-43
- ET 200B-4/8AI, 8-49
- ET 200B-4AI, 8-74
- ET 200B-4AO, 8-91
- ET 200B-8DI/8DO, 7-54
- ET 200B-16DI/16DO, 7-67
- ET 200B-16DI-AC, 7-78
- ET 200B-16DO, 7-31
- ET 200B-16DO/2A, 7-37
- ET 200B-16DO-AC, 7-83
- ET 200B-16RO-AC, 7-88
- ET 200B-8DI/8DO HWA, 7-61
- ET 200B-8DI/8RO-AC, 7-93
- ET 200B-8RO, 7-48

general, 6-1

terminal block, 1-3

- characteristics, 1-5
- definition, 1-5
- design, 2-2
- installing, 3-2
- TB1-4/DC, 7-6
- TB1/DC, 7-5
- TB2-4/DC, 7-9
- TB2/DC, 7-8
- TB3/DC, 7-7
- TB4/DC, 7-10
- TB4M/DC, 7-11
- TB6/AC, 7-12
- TB8-analog, 8-3
- wiring, 3-22

type file, A-2

- applications, 4-4
- designation, 4-4, A-2
- old type files, E-1
- provision, A-2

U

- UL/CSA, certification, 6-3
- ungrounded configuration, 3-20

W

- wire break, analog output module, 5-21
- wiring
 - bus interface, 3-26
 - terminal block, 3-22

Siemens AG
AUT E 148
Postfach 1963

D-92209 Amberg
Federal Republic of Germany

From:

Your Name: _ _ _ _ _

Your Title: _ _ _ _ _

Company Name: _ _ _ _ _

Street: _ _ _ _ _

City, Zip Code: _ _ _ _ _

Country: _ _ _ _ _

Phone: _ _ _ _ _

Please check any industry that applies to you:

- | | |
|--|--|
| <input type="checkbox"/> Automotive | <input type="checkbox"/> Pharmaceutical |
| <input type="checkbox"/> Chemical | <input type="checkbox"/> Plastic |
| <input type="checkbox"/> Electrical Machinery | <input type="checkbox"/> Pulp and Paper |
| <input type="checkbox"/> Food | <input type="checkbox"/> Textiles |
| <input type="checkbox"/> Instrument and Control | <input type="checkbox"/> Transportation |
| <input type="checkbox"/> Nonelectrical Machinery | <input type="checkbox"/> Other _ _ _ _ _ |
| <input type="checkbox"/> Petrochemical | |



