

Documentation

Synchronous Servomotor AM3000 and AM3500

Version: 1.5
Date: 2015-03-10

BECKHOFF

Documented motors

AM3tuv-wxyz	Standstill torque	Standstill current	Rated speed at rated supply voltage			Rotor moment of inertia		Weight	Weight
			230 V AC	400 V AC	480 V AC	without brake	with brake	without brake	with brake
AM3011-wB00	0.18Nm	1.16 A	8000 min ⁻¹	-	-	0,017 kg cm ²	0,021 kg cm ²	0,35 kg	0,55 kg
AM3012-wC00	0.31Nm	1.51 A	8000 min ⁻¹	-	-	0,031 kg cm ²	0,035 kg cm ²	0,49 kg	0,69 kg
AM3013-wC00	0.41Nm	1.48 A	8000 min ⁻¹	-	-	0,045 kg cm ²	0,049 kg cm ²	0,63 kg	0,83 kg
AM3021-wCyz	0.48 Nm	1.58 A	8000 min ⁻¹	-	-	0.107 kg cm ²	0.118 kg cm ²	0.82 kg	1.09 kg
AM3022-WCyz	0.84 Nm	1.39 A	3500 min ⁻¹	8000 min ⁻¹	8000 min ⁻¹	0.161 kg cm ²	0.172 kg cm ²	1.10 kg	1.37 kg
AM3023-wCyz	1.13Nm	1.41 A	2500 min ⁻¹	5500 min ⁻¹	7000 min ⁻¹	0.216 kg cm ²	0.227 kg cm ²	1.38 kg	1.65 kg
AM3024-wCyz	1.38Nm	1.42 A	2000 min ⁻¹	4500 min ⁻¹	5500 min ⁻¹	0.270 kg cm ²	0.281 kg cm ²	1.66 kg	1.93 kg
AM3024-wDyz	1.41 Nm	2.21 A	4000 min ⁻¹	8000 min ⁻¹	8000 min ⁻¹	0.270 kg cm ²	0.281 kg cm ²	1.66 kg	1.93 kg
AM3031-wCyz	1.15 Nm	1.37 A	2500 min ⁻¹	5000 min ⁻¹	6000 min ⁻¹	0.330 kg cm ²	0.341 kg cm ²	1.55 kg	1.90 kg
AM3031-wEyz	1.20 Nm	2.99 A	6000 min ⁻¹	-	-	0.330 kg cm ²	0.341 kg cm ²	1.55 kg	1.90 kg
AM3032-wCyz	2.00 Nm	1.44 A	1500 min ⁻¹	3000 min ⁻¹	3500 min ⁻¹	0.590 kg cm ²	0.601 kg cm ²	2.23 kg	2.58 kg
AM3032-wDyz	2.04 Nm	2.23 A	2500 min ⁻¹	5500 min ⁻¹	6000 min ⁻¹	0.590 kg cm ²	0.601 kg cm ²	2.23 kg	2.58 kg
AM3033-wCyz	2.71 Nm	1.47 A	1000 min ⁻¹	2000 min ⁻¹	2500 min ⁻¹	0.850 kg cm ²	0.861 kg cm ²	2.90 kg	3.25 kg
AM3033.wEyz	2.79 Nm	2.58 A	2000 min ⁻¹	4500 min ⁻¹	5000 min ⁻¹	0.850 kg cm ²	0.861 kg cm ²	2.90 kg	3.25 kg
AM3041-wCyz	1.95 Nm	1.46 A	1200 min ⁻¹	3000 min ⁻¹	3500 min ⁻¹	0.810 kg cm ²	0.878 kg cm ²	2.44 kg	3.07 kg
AM3041-wEyz	2.02 Nm	2.85 A	3000 min ⁻¹	6000 min ⁻¹	6000 min ⁻¹	0.810 kg cm ²	0.878 kg cm ²	2.44 kg	3.07 kg
AM3042-wEyz	3.42 Nm	2.74 A	1800 min ⁻¹	3500 min ⁻¹	4000 min ⁻¹	1.450 kg cm ²	1.518 kg cm ²	3.39 kg	4.02 kg
AM3042-wGyz	3.53 Nm	4.80 A	3500 min ⁻¹	6000 min ⁻¹	6000 min ⁻¹	1.450 kg cm ²	1.518 kg cm ²	3.39 kg	4.02 kg
AM3043-wEyz	4.70 Nm	2.76 A	1500 min ⁻¹	2500 min ⁻¹	3000 min ⁻¹	2.090 kg cm ²	2.158 kg cm ²	4.35 kg	4.98 kg
AM3043-wGyz	4.80 Nm	4.87 A	2500 min ⁻¹	5000 min ⁻¹	6000 min ⁻¹	2.090 kg cm ²	2.158 kg cm ²	4.35 kg	4.98 kg
AM3043-wHyz	4.82 Nm	5.4 A	3000 min ⁻¹	6000 min ⁻¹	-	2.090 kg cm ²	2.158 kg cm ²	4.35 kg	4.98 kg
AM3044-wEyz	5.76 Nm	2.90 A	1200 min ⁻¹	2500 min ⁻¹	2500 min ⁻¹	2.730 kg cm ²	2.798 kg cm ²	5.30 kg	5.93 kg
AM3044-wGyz	5.88 Nm	5.00 A	2000 min ⁻¹	4000 min ⁻¹	5000 min ⁻¹	2.730 kg cm ²	2.798 kg cm ²	5.30 kg	5.93 kg
AM3044-wHyz	5.89 Nm	5.6 A	2500 min ⁻¹	5000 min ⁻¹	6000 min ⁻¹	2.730 kg cm ²	2.798 kg cm ²	5.30 kg	5.93 kg
AM3044-wJyz	6.00 Nm	8.80 A	4000 min ⁻¹	6000 min ⁻¹	6000 min ⁻¹	2.730 kg cm ²	2.798 kg cm ²	5.30 kg	5.93 kg
AM3051-wEyz	4.70 Nm	2.75 A	1200 min ⁻¹	2500 min ⁻¹	3000 min ⁻¹	3.420 kg cm ²	3.593 kg cm ²	4.20 kg	5.30 kg
AM3051-wGyz	4.75 Nm	4.84 A	2500 min ⁻¹	5000 min ⁻¹	6000 min ⁻¹	3.420 kg cm ²	3.593 kg cm ²	4.20 kg	5.30 kg
AM3051-wHyz	4.79 Nm	6.00 A	3000 min ⁻¹	6000 min ⁻¹	6000 min ⁻¹	3.420 kg cm ²	3.593 kg cm ²	4.20 kg	5.30 kg
AM3052-wGyz	8.43 Nm	4.72 A	1500 min ⁻¹	2500 min ⁻¹	3000 min ⁻¹	6.220 kg cm ²	6.393 kg cm ²	5.80 kg	6.90 kg
AM3052-wHyz	8.48 Nm	5.9 A	1800 min ⁻¹	3500 min ⁻¹	4000 min ⁻¹	6.220 kg cm ²	6.393 kg cm ²	5.80 kg	6.90 kg
AM3052-wKyz	8.60 Nm	9.30 A	3000 min ⁻¹	5500 min ⁻¹	6000 min ⁻¹	6.220 kg cm ²	6.393 kg cm ²	5.80 kg	6.90 kg
AM3053-wGyz	11.37Nm	4.77 A	1000 min ⁻¹	2000 min ⁻¹	2400 min ⁻¹	9.120 kg cm ²	9.293 kg cm ²	7.40 kg	8.50 kg
Am3053-wHyz	11.51 Nm	6.60 A	-	3000 min ⁻¹	3500 min ⁻¹	9.120 kg cm ²	9.293 kg cm ²	7.40 kg	8.50 kg
AM3053-wKyz	11.60 Nm	9.40 A	2000 min ⁻¹	4000 min ⁻¹	4500 min ⁻¹	9.120 kg cm ²	9.293 kg cm ²	7.40 kg	8.50 kg
AM3054-wHyz	14.90 Nm	5.50 A	1000 min ⁻¹	1800 min ⁻¹	2000 min ⁻¹	12.92 kg cm ²	12.093 kg cm ²	9.00 kg	10.10 kg

AM3tuv-wxyz	Standstill torque	Standstill current	Rated speed at rated supply voltage			Rotor moment of inertia		Weight	Weight
			230 V AC	400 V AC	480 V AC	without brake	with brake	without brake	with brake
AM3054-wKyz	14.40 Nm	9.70 A	1800 min ⁻¹	3500 min ⁻¹	4000 min ⁻¹	11.92 kg cm ²	12.093 kg cm ²	9.00 kg	10.10 kg
AM3062-wHyz	11.90 Nm	5.40 A	1000 min ⁻¹	2000 min ⁻¹	2400 min ⁻¹	16.90 kg cm ²	17.51 kg cm ²	8.90 kg	10.90 kg
AM3062-wKyz	12.20 Nm	9.60 A	2000 min ⁻¹	3500 min ⁻¹	4500 min ⁻¹	16.90 kg cm ²	17.51 kg cm ²	8.90 kg	10.90 kg
AM3062-wMyz	12.20 Nm	13.40 A	3000 min ⁻¹	6000 min ⁻¹	6000 min ⁻¹	16.90 kg cm ²	17.51 kg cm ²	8.90 kg	10.90 kg
AM3063-wKyz	16.80Nm	9.90 A	1500 min ⁻¹	3000 min ⁻¹	3500 min ⁻¹	24.20 kg cm ²	24.81 kg cm ²	11.10 kg	13.10 kg
AM3063-wMyz	17.00 Nm	13.80 A	2000 min ⁻¹	4000 min ⁻¹	4500 min ⁻¹	24.20 kg cm ²	24.81 kg cm ²	11.10 kg	13.10 kg
AM3063-wNyz	17.00 Nm	17.40 A	3000 min ⁻¹	5000 min ⁻¹	6000 min ⁻¹	24.20 kg cm ²	24.81 kg cm ²	11.10 kg	13.10 kg
AM3064-wHyz	16.60 Nm	5.60 A	-	1500 min ⁻¹	1800 min ⁻¹	31.60 kg cm ²	32.21 kg cm ²	13.30 kg	15.30 kg
AM3064-wKyz	20.80 Nm	9.20 A	1200 min ⁻¹	2000 min ⁻¹	2500 min ⁻¹	31.60 kg cm ²	32.21 kg cm ²	13.30 kg	15.30 kg
AM3064-wLyz	21.00 Nm	12.80A	1500 min ⁻¹	3000 min ⁻¹	3500 min ⁻¹	31.60 kg cm ²	32.21 kg cm ²	13.30 kg	15.30 kg
AM3064-wPyz	20.40 Nm	18.60 A	2500 min ⁻¹	4500 min ⁻¹	5500 min ⁻¹	31.60 kg cm ²	32.21 kg cm ²	13.30 kg	15.30 kg
AM3065-wKyz	24.80 Nm	9.80 A	1000 min ⁻¹	2000 min ⁻¹	2200 min ⁻¹	40.00 kg cm ²	40.61 kg cm ²	15.40 kg	17.40 kg
AM3065-wMyz	25.00 Nm	13.60 A	1500 min ⁻¹	2500 min ⁻¹	3000 min ⁻¹	40.00 kg cm ²	40.61 kg cm ²	15.40 kg	17.40 kg
AM3065-wNyz	24.30 Nm	17.80 A	2000 min ⁻¹	3500 min ⁻¹	4000 min ⁻¹	40.00 kg cm ²	40.61 kg cm ²	15.40 kg	17.40 kg
AM3065-wPyz	24.50 Nm	19.80 A	3000 min ⁻¹	4000 min ⁻¹	5000 min ⁻¹	40.00 kg cm ²	40.61 kg cm ²	15.40 kg	17.40 kg
AM3072-wKyz	27.70 Nm	9.30 A	-	1500 min ⁻¹	1800 min ⁻¹	64.50 kg cm ²	66.14 kg cm ²	19.70 kg	21.80 kg
AM3072.wMyz	30.00 Nm	13.00 A	-	2000 min ⁻¹	2500 min ⁻¹	64.50 kg cm ²	66.14 kg cm ²	19.70 kg	21.80 kg
AM3072-wPyz	29.40 Nm	18.70 A	1800 min ⁻¹	3000 min ⁻¹	3500 min ⁻¹	64.50 kg cm ²	66.14 kg cm ²	19.70 kg	21.80 kg
AM3072-wQyz	29.70 Nm	20.90 A	-	3500 min ⁻¹	4000 min ⁻¹	64.50 kg cm ²	66.14 kg cm ²	19.70 kg	21.80 kg
AM3073-wMyz	42.00 Nm	13.60 A	-	1500 min ⁻¹	1800 min ⁻¹	92.10 kg cm ²	93.74 kg cm ²	26.70 kg	28.80 kg
AM3073-wMyz	41.60 Nm	19.50 A	1300 min ⁻¹	2400 min ⁻¹	2800 min ⁻¹	92.10 kg cm ²	93.74 kg cm ²	26.70 kg	28.80 kg
AM3073-wQyz	41.60 Nm	24.60 A	-	2500 min ⁻¹	3000 min ⁻¹	92.10 kg cm ²	93.74 kg cm ²	26.70 kg	28.80 kg
AM3074-wLyz	53.00 Nm	12.90 A	-	1200 min ⁻¹	1400 min ⁻¹	119.70 kg cm ²	121.64 kg cm ²	33.60 kg	35.70 kg
AM3074-wPyz	52.50 Nm	18.50 A	-	1800 min ⁻¹	2000 min ⁻¹	119.70 kg cm ²	121.64 kg cm ²	33.60 kg	35.70 kg
AM3074-wQyz	51.90 Nm	26.20 A	-	2500 min ⁻¹	3000 min ⁻¹	119.70 kg cm ²	121.64 kg cm ²	33.60 kg	35.70 kg
AM3082-wTyz	75.00 Nm	48.00 A	-	2500 min ⁻¹	3000	172 kg cm ²	177.53	65 kg	73
AM3083-wTyz	130.00 Nm	62.00 A	-	2200 min ⁻¹	2500	334 kg cm ²	339.53	85 kg	93
AM3084-wTyz	180.00 Nm	67.00 A	-	1800 min ⁻¹	2000	495 kg cm ²	500.53	105 kg	113
AM3541-w0yz	1.9 Nm	1.7 A	-	3000 min ⁻¹	-	2.0 kg cm ²	2.2 kg cm ²	2.4 kg	3.0 kg
AM3541-w1yz	1.9 Nm	2.8 A	-	6000 min ⁻¹	-	2.0 kg cm ²	2.2 kg cm ²	2.4 kg	3.0 kg
AM3542-w0yz	3.3 Nm	2.4 A	-	3000 min ⁻¹	-	4.0 kg cm ²	4.2 kg cm ²	3.8 kg	4.4 kg
AM3542-w1yz	3.3 Nm	4.5 A	-	6000 min ⁻¹	-	4.0 kg cm ²	4.2 kg cm ²	3.8 kg	4.4 kg
AM3543-w0yz	4.2 Nm	3.0 A	-	3000 min ⁻¹	-	8.0 kg cm ²	8.2 kg cm ²	5.35 kg	5.9 kg
AM3543-w1yz	4.2 Nm	5.2 A	-	6000 min ⁻¹	-	8.0 kg cm ²	8.2 kg cm ²	5.35 kg	5.9 kg
AM3551-w0yz	4.1 Nm	3.4 A	-	3000 min ⁻¹	-	15.0 kg cm ²	15.6 kg cm ²	5.8 kg	6.6 kg
AM3551-w1yz	4.1 Nm	6.1 A	-	6000 min ⁻¹	-	15.0 kg cm ²	15.6 kg cm ²	5.8 kg	6.6 kg
AM3552-w0yz	6.3 Nm	4.8 A	-	3000 min ⁻¹	-	19.0 kg cm ²	19.6 kg cm ²	7.0 kg	7.8 kg

AM3tuv-wxyz	Standstill torque	Standstill current	Rated speed at rated supply voltage			Rotor moment of inertia		Weight	
			230 V AC	400 V AC	480 V AC	without brake	with brake	without brake	with brake
AM3553-w0yz	8.6 Nm	6.4 A	-	3000 min ⁻¹	-	20.0 kg cm ²	20.6 kg cm ²	8.9 kg	9.7 kg
AM3562-w0yz	11.6 Nm	10.3 A	-	3000 min ⁻¹	-	40.0 kg cm ²	42.0 kg cm ²	10.7 kg	11.8 kg
AM3563-w0yz	14.9 Nm	12.5 A	-	3000 min ⁻¹	-	60.0 kg cm ²	62.0 kg cm ²	13.6 kg	14.7 kg

Chapter	Page
Table of contents – AM3000 and AM3500	
Documented motors	2
Table of contents – AM3000 and AM3500	5
1 Foreword	7
1.1 Notes on the documentation	7
1.2 Disclaimer	7
1.3 Brands	7
1.4 Patents	7
1.5 Copyright	7
1.6 Documentation issue status	7
1.7 Appropriate use	8
2 Guidelines and Standards	9
2.1 EC declaration of conformity	9
3 Safety	10
3.1 General safety instructions	10
3.1.1 Personnel qualification	10
3.1.2 Description of safety symbols	10
3.2 Special safety instructions for AM3000 and AM3500	11
4 Handling	12
4.1 Transport	12
4.2 Packaging	12
4.3 Storage	12
4.4 Maintenance / Cleaning	12
4.5 Disposal	13
5 Product identification	14
5.1 AM3000, scope of supply	14
5.2 AM3000 nameplate	14
5.3 AM3000 type key	14
5.4 AM3500, scope of supply	15
5.5 AM3500 nameplate	15
5.6 AM3500 type key	15
6 Technical description	16
6.1 Design of the motors	16
6.2 General technical data	16
6.3 Standard features	17
6.3.1 Style	17
6.3.2 Shaft end, A-side	17
6.3.3 Flange	17
6.3.4 Protection class	17
6.3.5 Overtemperature protection	17
6.3.6 Insulation material class	17
6.3.7 Vibration class	18
6.3.8 Connection technology	18
6.3.9 Feedback unit	18
6.3.10 Holding brake	18
6.3.11 Pole numbers	19
6.4 Options	19
6.5 Selection criteria	19
7 Mechanical installation	20
7.1 Important notes	20
8 Electrical installation	21
8.1 Important notes	21
8.2 Connection of motors with pre-assembled cables	22
8.2.1 AX5000	22
8.2.2 AX2000 and AX2500	26
8.3 AX5000 connection diagram for motors with EnDAT / BiSS encoder	29

8.4	AX5000 connection diagram for motors with resolver	30
8.5	AX5000 connection diagram for motors with resolver and yTec-Plug	31
8.6	AX2000 connection diagram for motors with EnDAT / BiSS encoder	32
8.7	AX2000 connection diagram for motors with resolver	33
9	Commissioning	34
9.1	Important notes	34
9.2	Guide for commissioning.....	34
9.3	Troubleshooting	34
10	Technical data	36
10.1	Term definitions.....	36
10.2	AM301x	37
10.2.1A	Dimensional drawing.....	38
10.2.1B	Dimensional drawing.....	38
10.2.2	Radial / axial forces at the shaft end	39
10.2.3	Characteristic torque / speed curves	39
10.3	AM302x	40
10.3.1	Dimensional drawing.....	41
10.3.2	Radial / axial forces at the shaft end	41
10.3.3	Characteristic torque / speed curves	41
10.4	AM303x	42
10.4.1	Dimensional drawing.....	43
10.4.2	Radial / axial forces at the shaft end	43
10.4.3	Characteristic torque / speed curves	43
10.5	AM304x	44
10.5.1	Dimensional drawing.....	45
10.5.2	Radial / axial forces at the shaft end	45
10.5.3	Characteristic torque / speed curves	45
10.6A	AM305x (AM3051; AM3052).....	46
10.6B	AM305x(AM3053 and AM3054).....	47
10.6.1	Dimensional drawing.....	48
10.6.2	Radial / axial forces at the shaft end	48
10.6.3	Characteristic torque / speed curves	48
10.7	AM306x	49
10.7.1	Dimensional drawing.....	50
10.7.2	Radial / axial forces at the shaft end	50
10.7.3	Characteristic torque / speed curves	50
10.8	AM307x	51
10.8.1	Dimensional drawing.....	52
10.8.2	Radial / axial forces at the shaft end	52
10.8.3	Characteristic torque / speed curves	52
10.9	AM308x	53
10.9.1	Dimensional drawing.....	54
10.9.2	Radial / axial forces at the shaft end	55
10.9.3	Characteristic torque / speed curves	55
10.10	AM354x	56
10.10.1	Dimensional drawing.....	57
10.10.2	Characteristic torque / speed curves	58
10.11	AM355x	59
10.11.1	Dimensional drawing.....	60
10.11.2	Characteristic torque / speed curves	61
10.12	AM356x	62
10.12.1	Dimensional drawing.....	63
10.12.2	Characteristic torque / speed curves	64
11	Appendix	65
11.1	Support and Service.....	65
11.1.1	Beckhoff Support.....	65
11.1.2	Beckhoff Service	65
11.2	Beckhoff headquarters	65

1 Foreword

1.1 Notes on the documentation

This description is only intended for trained specialists in control, automation and drive engineering who are familiar with the applicable national standards. It is essential that the following notes and explanations are followed when installing and commissioning these components. The "General safety instructions" and "Special safety instructions for AM3000 and AM3500" sections are also essential.

The responsible staff must ensure that the application or use of the products described satisfy all the requirements for safety, including all the relevant laws, regulations, guidelines and standards.

 CAUTION	<p>Danger for persons, the environment or equipment</p> <p>The motors are operated in the drive system in conjunction with Beckhoff servo drives. Please observe the entire documentation which consists of:</p> <ul style="list-style-type: none"> – AM3000 and AM3500 documentation (this manual) – Complete documentation (online and paper) for Beckhoff servo drives available at www.beckhoff.com. – Complete machine documentation (provided by the machine manufacturer)
---	--

1.2 Disclaimer

This documentation has been prepared with care. The products described are, however, constantly under development.

For this reason, the documentation may not always have been fully checked for consistency with the performance data, standards or other characteristics described.

If it should contain technical or editorial errors, we reserve the right to make changes at any time and without notice.

No claims for the modification of products that have already been supplied may be made on the basis of the data, diagrams and descriptions in this documentation.

1.3 Brands

Beckhoff®, TwinCAT®, EtherCAT®, Safety over EtherCAT®, TwinSAFE® and XFC® are registered and licensed brand names of Beckhoff Automation GmbH.

The use by third parties of other brand names or trademarks contained in this documentation may lead to an infringement of the rights of the respective trademark owner.

1.4 Patents

The TwinCAT technology is patent protected, in particular by the following applications and patents: EP0851348, US6167425 with the corresponding applications and registrations in various other countries.

1.5 Copyright

© Beckhoff Automation GmbH & Co. KG.

The copying, distribution and utilisation of this document as well as the communication of its contents to others without express authorisation is prohibited.

Offenders shall be held liable for damages. All rights conferred by patent grant or registration of a utility model or registered design are reserved.

1.6 Documentation issue status

Issue	Comment
1.5	<p>Chapter update: 8.4; 8.5; 8.6; 8.7; 10.2; 10.9.1</p> <p>New chapter: 10.2.1B</p>
1.4	<p>Chapter update: Documented motors; 5.3; 6.3.2; 6.3.6; 8.2.1; 8.2.2; 10.2; 10.3; 10.4; 10.5; 10.5.1; 10.6; 10.7; 10.8; 10.9; 10.9.1; 10.10; 10.10.1; 10.11; 10.12; 10.12.1</p>
1.3	<p>Chapter update: 6.3.10</p>

Issue	Comment
1.2	Chapter update: Documented motors; 10.2; 10.3; 10.4; 10.5; 10.6; 10.7; 10.8; 10.9
1.1	Chapter update: Documented motors; 5.3; 10.2; 10.3; 10.4; 10.5; 10.6; 10.7; 10.8; 10.9; 10.10; 10.11; 10.12 New chapter: 8.5
1.0	First issue (description of the AM3000 and AM3500 motors consolidated in one document and amended)

1.7 Appropriate use

Synchronous servomotors of the AM3000 and AM3500 series are designed as drives for handling equipment, textile machines, machine tools, packaging machines and similar machines with demanding requirements in terms of dynamics. The motors of the AM3000 and AM3500 series are **exclusively** intended for speed- and/or torque-controlled operation via digital servo drives from Beckhoff.

The thermal protection contact incorporated in the motor windings must be analysed and monitored.

 WARNING	Caution – Risk of injury! Electronic equipment is not fail-safe. The machine manufacturer is responsible for ensuring that the connected motors and the machine are brought into a safe state in the event of a fault in the drive system.
---	--

The servomotors from the AM3000 and AM3500 series are exclusively designed for installation as components in electrical systems or machines and may only be operated as integrated components of the system or machine.

The motors may **only** be operated under the ambient conditions defined in this documentation.

2 Guidelines and Standards

 CAUTION	<p>Danger for persons, the environment or equipment</p> <p>Servomotors of the AM3000 and AM3500 series are not classified as products within the meaning of the EC Machinery Directive. Operation of the servomotors in machines or systems is only permitted once the machine or system manufacturers has provided evidence of CE conformity of the complete machine or system.</p>
---	--

2.1 EC declaration of conformity

We,

Beckhoff Automation GmbH & Co. KG
 Hülshorstweg 20
 33415 Verl
 Germany

hereby declare, under our sole responsibility, that the product range

motor series AM3000
 (types **AM301x, AM302x, AM303x, AM304x, AM305x, AM306x, AM307x, AM308x**)

motor series AM3500
 (types **AM354x, AM355x, AM 356x**)

complies with following relevant regulations:

- EC Directive 2004/108/EC
 Electromagnetic compatibility
 Applied harmonised standard EN 61800-3
- EC Directive 2006/95/EC
 Electrical equipment designed for use within certain voltage limits
 Applied harmonised standard EN 61800-5-1

Attachment of the CE marking: 2007

Issued by: Management

H. Beckhoff

Verl, 25.05.2007

3 Safety







3.1 General safety instructions

3.1.1 Personnel qualification

This description is only intended for trained specialists in control, automation and drive engineering who are familiar with the applicable national standards.

3.1.2 Description of safety symbols

The following safety symbols and associated safety instructions are used in this document. These safety instructions must be read and followed.

 DANGER	<p>Serious risk of injury! Failure to follow the safety instructions associated with this symbol directly endangers the life and health of persons.</p>
 WARNING	<p>Caution – Risk of injury! Failure to follow the safety instructions associated with this symbol endangers the life and health of persons.</p>
 CAUTION	<p>Personal injuries! Failure to follow the safety instructions associated with this symbol can lead to injuries to persons.</p>
 Attention	<p>Damage to the environment or devices! Failure to follow the safety instructions associated with this symbol can lead to damage to the environment or equipment.</p>
 Note	<p>Tip or pointer This symbol indicates information that contributes to better understanding.</p>
	<p>UL note This symbol indicates important information regarding UL certification.</p>

3.2 Special safety instructions for AM3000 and AM3500

The safety instructions are designed to avert danger and must be followed during installation, commissioning, production, troubleshooting, maintenance and trial or test assemblies. The servomotors of the AM3000 and AM3500 series are not designed for stand-alone operation and are always installed in a machine or system. After installation the additional documentation and safety instructions provided by the machine manufacturer must be read and followed.

 WARNING	<p>Serious risk of injury through high electrical voltage!</p> <ul style="list-style-type: none"> • Never open the servomotor when it is live. The measured voltage between terminals U, V and W must have dropped below 50 V. Opening the device would invalidate any warranty and liability claims against Beckhoff Automation GmbH & Co. KG. • Negligent, improper handling of the servomotor and bypassing of the safety devices can lead to personal injury or death through electric shock. • Ensure that the protective conductor is connected properly. • The machine manufacturer must prepare a hazard analysis for the machine, and must take appropriate measures to ensure that unexpected movements can not lead to injury to persons or to material damage. • Power leads may be live, even if the motor is not running. Never undo the electrical connections to the motor when it is live. Under unfavourable conditions arcing may occur, resulting in injury and damage to contacts. • Disconnect the servomotor from the servo drive and secure it against reconnection before working on electrical parts with a voltage > 50 V. • The DC link voltage of the servo drive may exceed 890 V. Wait until the DC link capacitors are discharged before touching live terminals. The measured voltage between terminals DC+ and DC- (X02) must have dropped below 50 V.
---	---

 WARNING	<p>Serious risk of injury through hot surfaces!</p> <ul style="list-style-type: none"> • The surface temperature may exceed 50 °C, resulting in a risk of burns. • Avoid touching the housing during or shortly after operation. • Leave the servomotor to cool down for at least 15 minutes after it is switched off. • Use a thermometer to check whether the surface has cooled down sufficiently.
---	--

 Attention	<p>Danger for persons, the environment or equipment</p> <ul style="list-style-type: none"> • Carefully read this manual before using the servomotor thoroughly, paying particular attention to the safety instructions. In the event of any uncertainties please notify your sales office immediately and refrain from working on the servomotor. • Only well trained, qualified electricians with sound knowledge of drive equipment may work on the device. • During installation it is essential to ensure that the specified ventilation clearances and climatic conditions are adhered to. Further information can be found in the "Technical data" and "Mechanical installation" sections. • If a servomotor is installed in a machine it must not be commissioned until proof of compliance of the machine with the latest version of the EC Machinery Directive has been provided. This includes all relevant harmonised standards and regulations required for implementation of this Directive in national legislation.
---	--

4 Handling

4.1 Transport

- Climate category: 2K3 according to EN 50178
- Transport temperature: -25 °C - +70 °C, max. fluctuation 20 K/hour
- Transport humidity: relative humidity 5% - 95%, non-condensing
- The servomotor may only be transported by qualified personnel and in the manufacturer's original recyclable packaging.
- Avoid hard impacts, particularly at the shaft end.
- If the packaging is damaged, check the motor for visible damage. Inform the transport company and, if necessary, the manufacturer.

4.2 Packaging

- Cardboard packaging with Instapak[®] foam cushion.
- You can return the plastic portion to the supplier (see Disposal)

Motor type	Carton	Max. stacking height
AM301x	X	10
AM302x	X	10
AM303x	X	6
AM304x	X	6
AM305x	X	5
AM306x	X	1
AM307x	X	1
AM308x	X	1

4.3 Storage

- Climate category 1K4 according to EN50178
- Storage temperature: -25 °C - +55 °C, max. fluctuation 20 K/hour
- Air humidity: relative humidity 5% - 95%, non-condensing
- Max. stacking height: see table Packaging
- Storage time: without limitation
- Store only in the manufacturer's original recyclable packaging

4.4 Maintenance / Cleaning

- Maintenance and cleaning only by qualified personnel.
- The ball bearings have a grease filling with a service life of 20,000 hours under normal operating conditions. The bearings should be replaced after 20,000 hours of operation under rated conditions.
- Check the motor for bearing noise every 2,500 operating hours or once per year. If any noises are heard, stop the operation of the motor. The bearings must be replaced.
- Opening the motor invalidates the warranty.
- Clean the housing with isopropanol or similar.



Attention

Destruction of the servomotor

Never immerse or spray the servomotor.

4.5 Disposal

- In accordance with the WEEE 2002/96/EC Directives we take old devices and accessories back for professional disposal, provided the transport costs are taken over by the sender. Please send the devices to:

Beckhoff Automation GmbH & Co. KG

Eiserstrasse 5

33415 Verl

Germany

5 Product identification

5.1 AM3000, scope of supply

Please check that the delivery includes the following items:

- Motor from the AM3000 series
- Motor package leaflet (short info)

5.2 AM3000 nameplate

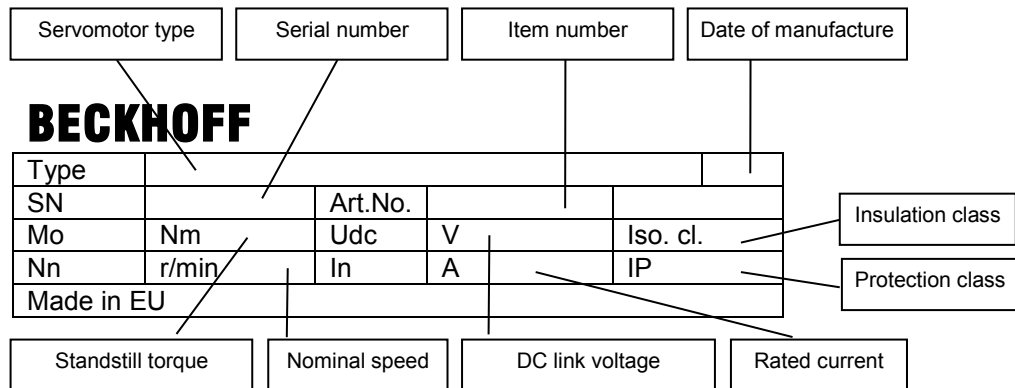

5.3 AM3000 type key

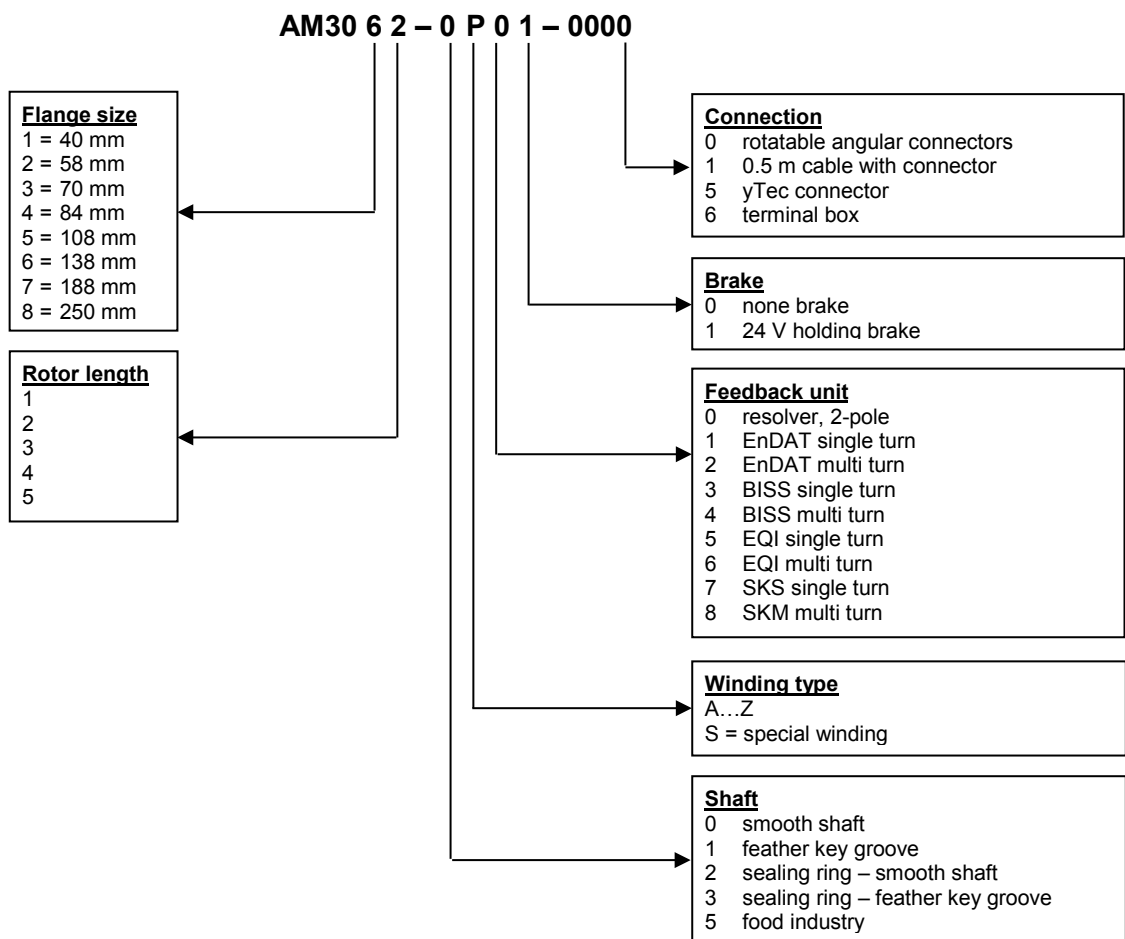

5.4 AM3500, scope of supply

Please check that the delivery includes the following items:

- Motor from the AM3500 series
- Motor package leaflet (short info)

5.5 AM3500 nameplate

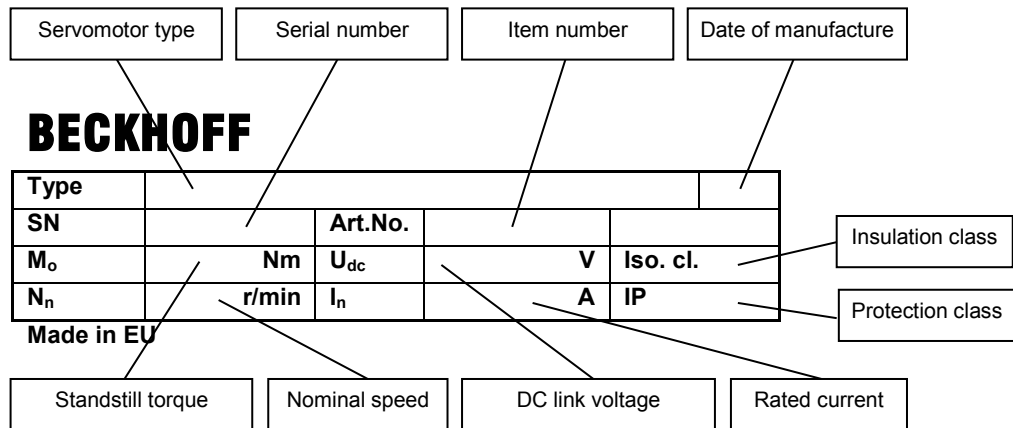

5.6 AM3500 type key

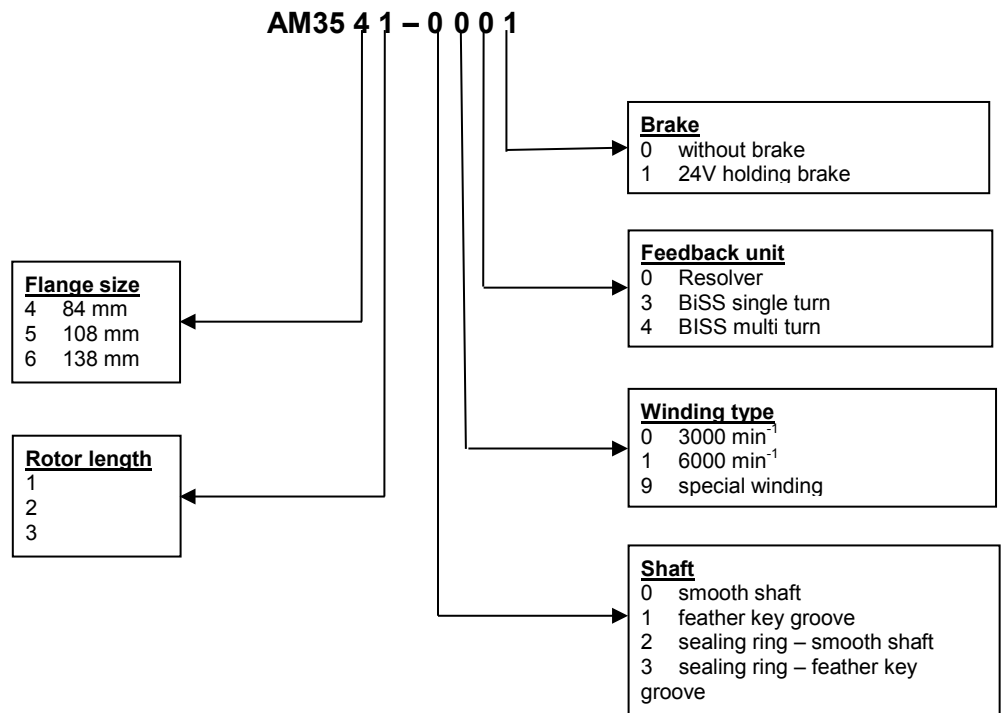

6 Technical description

6.1 Design of the motors

The synchronous servomotors of the AM3000 and AM3500 series are brushless three-phase motors for demanding servo-applications. In conjunction with our digital servo drives they are particularly suitable for positioning tasks in industrial robots, machine tools, transfer lines etc. with demanding requirements in terms of dynamics and stability.

The servomotors are equipped with permanent magnets in the rotor. This advanced neodymium magnetic material makes a significant contribution to the motors' exceptional dynamic properties. A three-phase winding is housed in the stator, and this is powered by the servo drive. The motor has no brushes, the commutation being implemented electronically in the servo drive.

The temperature of the winding is monitored by temperature sensors in the stator windings and is signalled via an electrically isolated thermistor (PTC, $\approx 550 \Omega$ / $\approx 1330 \Omega$).

The motors normally have an integrated resolver to provide feedback. Beckhoff servo drives analyse the resolver position of the rotor and supply the motors with sine currents. The optional feedback systems may require modification of the motor length and cannot be retrofitted.

The motors are available with or without built-in holding brake. The brake cannot be retrofitted.

The motors have a matt black coating (RAL 9005). The finish is not resistant against solvents (e.g. trichlorethylene, thinners or similar). The "Washdown"-model is white coated and FDA (Food and Drug Administration) conform.

6.2 General technical data

Climate category	3K3 according to EN 50178
Ambient temperature (at rated values)	+5 - +40 °C for site altitudes up to 1000 m amsl It is vital to consult our applications department for ambient temperatures above 40 °C and encapsulated installation of the motors.
Permissible humidity (at rated values)	95% relative humidity, non-condensing
Power derating (currents and torques)	For site altitudes above 1000 m amsl and 40 °C 6% at 2000 m amsl 17% at 3000m amsl 30% at 4000m amsl 55% at 5000m amsl No derating for site altitudes above 1000 m amsl with temperature reduction of 10K / 1000m
Ball bearing service life	\approx 20,000 operating hours
Technical data	→ see Section 10
Storage and transport data	→ see Section 4

6.3 Standard features

6.3.1 Style

The basic style for the AM3000 and AM3500 synchronous servomotors is IM B5 according to DIN EN 60034-7.

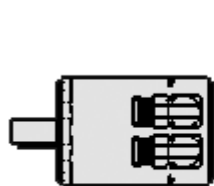

IM B 5 (B5)



IM V 3 (V3)



IM V 1 (V)

The permitted mounting positions are specified in the technical data.

6.3.2 Shaft end, A-side

Power transmission is made through the cylindrical shaft end A, fit k6 (AKM1: h7) according to EN 50347, with a locking thread or optionally with a **feather key groove**. The bearings are designed for a service life of 20,000 hours.

Radial force

If the motors drive via pinions or toothed belts, then high radial forces will occur. The permissible values at the shaft end, depending on the speed, may be read from the diagrams in the Section 10. The permissible maximum values can be found in the technical data. Power take-off from the middle of the free end of the shaft allows a 10% increase in FR.

Axial force

Axial forces arise when assembling pinions or pulleys on the shaft and using angular gearheads, for example. The permissible maximum values can be found in the technical data.

Coupling

Double-coned collets, possibly in association with metal bellows couplings, have proven themselves as excellent, zero backlash coupling elements.

6.3.3 Flange

Flange dimensions according to IEC standard, fit j6 (AM301x: h7), accuracy according to DIN 42955
Tolerance class: **N**

6.3.4 Protection class

Standard version	IP65
Standard shaft bushing	IP54
Shaft bushing with shaft sealing ring	IP67

6.3.5 Overtemperature protection

The standard version of each motor is fitted with an electrically isolated PTC with a rated temperature of 155 °C ± 5%. The PTC does **not** provide any protection against short, heavy overloading.

Provided that our preassembled cable is used, the PTC is integrated into the monitoring system of the digital servo drives.

6.3.6 Insulation material class

The motors conform to insulation material class F according to IEC 60085 (UL 1446 class F).

6.3.7 Vibration class

The motors are made to vibration class A according to DIN EN 60034-14. For a speed range of 600-3600 rpm and a shaft centre height between 56-132 mm, this means that the actual value of the permitted vibration severity is 1.6 mm/s.

Speed [rpm]	Max. rel. vibration displacement [μm]	Max. run-out [μm]
≤ 1800	90	23
> 1800	65	16

6.3.8 Connection technology

The motors are fitted with angular connectors (AM301x: straight connectors at the cable ends) for the power supply and the feedback signals.

The mating connectors are not included in the scope of supply. We can supply preassembled feedback and power cables. Information regarding the cable materials can be found in Section 8.2.

6.3.9 Feedback unit

Standard	Resolver	Two-pole, hollow shaft
Option	EnDAT Encoder, Singleturn	AM302x-AM304x: ECN 1113, AM305x-AM307x: EQN 1325
Option	EnDAT Encoder, Multiturn	AM302x-AM304x: EQN 1125 AM305x-AM307x: EQN 1325
Option	BiSS Encoder, Single- / Multiturn	AM302x-AM304x: AD36 AM305x-AM307x: AD58
Option	BiSS Encoder, Single- / Multiturn	AM35xx: AD34



Note

Motor length

The motor length depends on the built-in feedback unit, among other factors. Retrofitting is not possible.

6.3.10 Holding brake



WARNING

Serious risk of injury!

The holding brake is not personal safety. If the brake is released then the rotor can be moved without a remanent torque!

The AM302x-AM308x and AM35xx motors are optionally available with an in-built holding brake. The AM3000 model features a spring-actuated brake (24 V DC), the AM3500 features a permanent-magnet brake (24 V DC). When the brake is de-energised it blocks the rotor. **The holding brakes are designed as standstill brakes** and are not suited for repeated operational braking.

The holding brakes can be controlled directly by the servo drive (no personal safety!), in which case the brake winding is suppressed in the servo drive. Additional circuitry is not required.

If the holding brake is not controlled directly by the servo drive, additional circuitry (e.g. varistor) is required. Consult our applications department beforehand.



Note

Motor length

The motor length depends on the built-in holding brake, among other factors. It is not possible to fit one at a later date.

6.3.11 Pole numbers

Motor	Poles	Motor	Poles	Motor	Poles	Motor	Poles
AM301x	6	AM304x	10	AM307x	10	AM354x	10
AM302x	6	AM305x	10	AM308x	10	AM355x	10
AM303x	8	AM306x	10			AM356x	10

6.4 Options

Holding brake

The holding brake is integrated in the motor. It increases the motor length.

Radial shaft-sealing ring

Radial shaft-sealing ring (Teflon) for sealing against oil mist and oil spray. This increases the protection class of the shaft bushing to IP67.

Feather key

The motors are available with feather key groove and fitted feather key according to DIN6885. The rotor is balanced with half a feather key.

EnDat (only AM30xx), BiSS

This model features a different feedback system in place of the resolver, which may result in an increase of the motor length.



Note

Installation options and reduction of rated values

With the exception of the sealing ring, the options cannot be retrofitted.

Options such as sealing ring, holding brake, EnDAT or BiSS can lead to a reduction of the rated data.

6.5 Selection criteria

The three-phase servomotors are designed for operation with servo drives. Both units together form a speed or torque control loop.

The main selection criteria are:

- | | |
|---------------------------------------|-------------------|
| — Standstill torque | M0 [Nm] |
| — Rated speed at rated supply voltage | nn [min-1] |
| — Moment of inertia of motor and load | J [kgcm²] |
| — Effective torque (calculated) | Mrms [Nm] |

The static load **and** the dynamic load (acceleration/braking) must be taken into account in the calculation of the required motors and servo drives. Formulas and calculation example are available from our applications department on request.

7 Mechanical installation

7.1 Important notes



Attention

Destruction of the motors



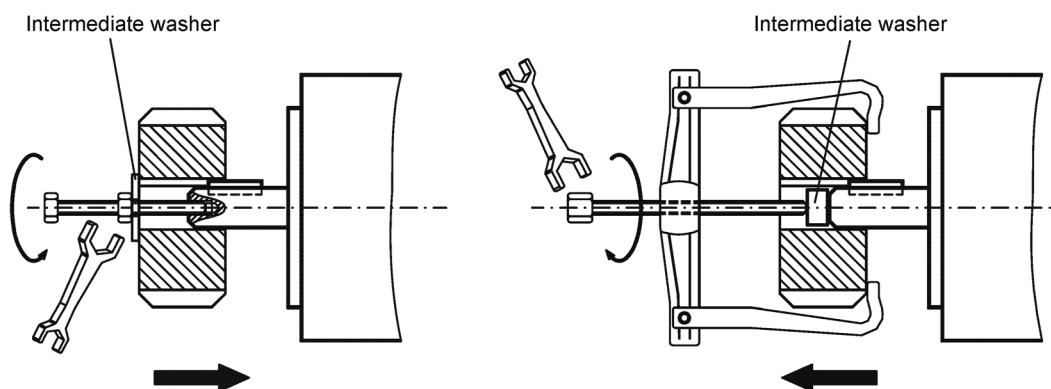

- Protect the motors from unacceptable stresses. Take care, especially during transport and handling, that components are not bent and that insulation clearances are not altered.
- The site must be free of conductive and aggressive material. For V3-mounting (shaft end upwards), make sure that no liquids can enter the bearings. If an encapsulated assembly is required, please consult our applications department beforehand.
- Ensure unhindered ventilation of the motors and observe the permissible ambient and flange temperatures. For ambient temperatures above 40 °C please consult our applications department beforehand.
- Servomotors are precision devices. The flange and shaft are especially vulnerable during storage and assembly. It is important to use the locking thread which is provided to tighten up couplings, gear wheels or pulleys and warm up the drive components, where possible. Blows or the use of force will lead to damage to the ball bearings and the shaft.



- Wherever possible, use only backlash-free, frictionally-locking collets or couplings. Ensure correct alignment of the couplings. A displacement will cause unacceptable vibration and the destruction of the ball bearings and the coupling.
- For toothed belts, it is vital to observe the permissible radial forces. An excessive radial load on the shaft will significantly shorten the life of the motor.
- Avoid axial loads on the motor shaft, as far as possible. Axial loading significantly shortens the life of the motor.
- In any case, avoid creating a mechanically constrained motor shaft mounting by using a rigid coupling with additional external bearings (e.g. in a gearbox).
- Take note of the no. of motor poles and the no. of resolver poles and ensure that the correct setting is made in the used servo drives. An incorrect setting can lead to the destruction of the motor, especially with small motors.
- Check compliance the permitted radial and axial loads F_R and F_A . When using a toothed belt drive, the **minimum** permitted diameter of the pinion follows from the equation: $d_{\min} \geq \frac{M_0}{F_R} \times 2$

8 Electrical installation

8.1 Important notes

 DANGER	<p>Serious risk of injury through electric shock!</p> <ul style="list-style-type: none"> • Only staff qualified and trained in electrical engineering are allowed to wire up the motor. • Check the assignment of the servo drive and the motor. Compare the rated voltage and the rated current of the devices. • Always make sure that the motors are de-energised during assembly and wiring, i.e. no voltage may be switched on for any piece of equipment which is to be connected. Ensure that the control cabinet remains turned off (barrier, warning signs etc.). The individual voltages will only be turned on again during commissioning. • Never undo the electrical connections to the motor when it is live. A dangerous voltage, resulting from residual charge, can be still present on the capacitors up to 5 minutes after switch-off of the mains supply. Measure the DC link voltage and wait until it has fallen below 40 V. Control and power leads may be live, even if the motor is not running.
 Attention	<p>Smooth operation</p> <ul style="list-style-type: none"> • Ensure that there the servo drive and the motor are earthed properly. See below for further information regarding EMC shielding and earthing. Earth the mounting plate and motor housing. Further details of connection types can be found in Section 8.2 • Route the power and control cables as separately as possible from one another (separation > 20 cm). This will improve the immunity of the system to electromagnetic interference. If a motor power cable is used which includes integral brake control leads, then these brake control leads must be shielded. The shielding must be connected at both ends (see below). • Install all cables carrying a heavy current with an adequate cross-section, as per EN 60204. The recommended cross-section can be found in the technical data. • Wiring: <ul style="list-style-type: none"> Connect the resolver or encoder Connect the motor cables Connect shields to shield terminals or EMC connectors at both ends Connect the temperature contact Connect the motor holding brake
 Attention	<p>HF interference</p> <ul style="list-style-type: none"> • The ground symbol , which you will find in the wiring diagrams, indicates that you must provide an electrical connection, with as large a surface area as possible, between the unit indicated and the mounting plate in the control cabinet. This connection is to suppress HF interference and must not be confused with the PE (protective earth) symbol (protective measure according to EN 60204). Follow the instructions in the circuit diagrams in Sections 8.3 to 8.6
 Note	<p>Long motor cables</p> <ul style="list-style-type: none"> • In case of long motor cables (>25m) a motor choke must be provided between the motor and the servo drive. AX2000 / AX2500: Connect up all shielding via a wide surface-area contact (low impedance) and metallised connector housings or EMC cable glands. Install the motor choke close to the servo drive. AX5000: The motor choke is supplied with a connection cable. Do not alter the configuration (cable length, cross-section etc.).

8.2 Connection of motors with pre-assembled cables

Beckhoff offers preassembled motor and feedback cables for safe, faster and flawless installation of the motors. Beckhoff cables have been tested with regard to the materials, shielding and connectors used. They ensure proper functioning and compliance with statutory regulations such as EMC, UL etc. The use of other cables may lead to unexpected interference and invalidate the warranty.

- Carry out the wiring in accordance with the valid standards and regulations.
- Only use our preassembled shielded cables for the power and feedback connections.
- Connect up the shielding according to the wiring diagrams in sections 8.3 to 8.6. Incorrectly installed shielding inevitably leads to EMC interference.

All available cable types are listed below. Should you require additional information please contact our support.

8.2.1 AX5000

All cables are UL-listed.

8.2.1.1 Cables for fixed installation

Motor cable with signal line

Specification	4 x 1.5 mm ² + 2 x (2 x 0.75 mm ²)
General data	
Weight	kg / km
Min. bending radius	203 mm
Overall diameter	11.3 mm +/- 4%
Max. velocity	180 m/min
Max. acceleration	5 m/s ²
Max. no. of cycles	50.000
Max. tensile load	20 N/mm ²
Operating temperature	-10 to 80 °C
Standards and features	
UL AWM listed	80 °C – 1000 V
CSA AWM listed	75 °C – 1000 V
VDE (U ₀ / U)	0.6/1 kV
Flame resistance	DIN EN 50265-2-1
Oil resistance	UL 1581
Silicone-free	yes
CFC-free	yes
Halogen-free	no
Sheath	
Material	PVC according to UL AWM & CSA AWM
Shielding	tinned copper braid, optical cover ≥ 85%
Separator	Polyester strap
Colour	RAL 2003 (orange)
Power leads	4 x 1.5 mm ²
Conductor material	blank copper cl.5 (DIN EN 60228; VDE 0295; IEC 60228)
Insulation	TEO Flexene ® polymer compound, compliant with UL AWM & CSA AWM
Colour code	black (1 -3) + green/yellow
Signal leads	2 x (2 x 0.75 mm ²)
Conductor material	blank copper cl. 5 (DIN EN 60228; VDE 0295; IEC 60228)
Insulation	TEO Flexene ® polymer compound, compliant with UL AWM & CSA AWM
Structure	pair-wise twisted
Shielding per pair	tinned copper sheath, optical cover ≥ 85%
Separator	fleece tape
Colour code for signal pairs	2 pairs

1 st pair	black and black (5-6)
2 nd pair	black and black (7-8)
Electrical specifications	
Test conditions	20 °C
Test voltage for power leads (conductor/conductor - conductor/shielding)	4 kV eff. 5 min.
Test voltage for signal leads (conductor/conductor - conductor/shielding)	2 kV eff. 1 min.
Requirement	undamaged insulation
Operating voltage	≤1000 V
Conductor resistance	IEC 60228 Cl.5
Insulation resistance	≥2500 MOhm x km
<u>Capacitance:</u>	
Power	max. 150 pF / m
Signals	max. 100 pF / m

Encoder cable

Specification	Encoder cable 7x(2x0.14mm ²)+1x(2x0.5mm ²)	Reserved
General data		
Weight	kg / km	
Min. bending radius	137 mm	
Overall diameter	7.6 mm +/- 0.3 mm	
Max. velocity	180 m / min	
Max. acceleration	5 m / s ²	
Max. no. of cycles	50.000	
Max. tensile load	20 N / mm ²	
Operating temperature	-10 to 80 °C	
Standards and features		
UL AWM listed	80 °C – 30 V	
CSA AWM listed	75 °C – 30 V	
Flame resistance	DIN EN 50265-2-1	
Oil resistance	UL 1581	
Silicone-free	yes	
CFC-free	yes	
Halogen-free	no	
Sheath		
Material	PVC according to UL AWM & CSA AWM	
Shielding	tinned copper braid, optical cover ≥ 85%	
Separator	Polyester strap	
Colour	RAL 6018 (green)	
Signal leads	7 x (2 x 0.14 mm ²)	
Conductor material	tinned copper 7x0.16 mm	
Conductor resistance	≤140 Ohm / km	
Insulation	polypropylene compliant with UL AWM & CSA AWM	
Structure	pair-wise twisted	
Colour code for signal pairs	8 pairs	
1 st pair	brown and white	
2 nd pair	green and yellow	
3 rd pair	grey and pink	
4 th pair	red and blue	
5 th pair	black and violet	

6 th pair	grey/pink and red/blue	
7 th pair	white/green and brown/green	
8 th pair	white/yellow and yellow/brown	
Electrical specifications		
Test conditions	20 °C	
Test voltage (conductor/conductor - conductor/shielding) Requirement	1500 VDC undamaged insulation	
Operating voltage	≤ 30 V	
Conductor material	2 x 0.5 mm ² , tinned copper 19 x 0.18 mm	
Conductor resistance	0.5 mm ² ≤ 40 Ohm / km	
Insulation resistance	min. 2500 MOhm x km	
<u>Capacitance:</u>		
Power	max. 100 pF / m	
Signals	max. 120 pF / m	

8.2.1.2 Cables for flexible installation / highly dynamic operation

Motor cable with signal line

Specification	4 x 1.5 mm ² + 2 x (2 x 0.75 mm ²)
General data	
Weight	kg / km
Min. bending radius	85 mm
Overall diameter	12.2 mm ± 4mm
Max. velocity	240 m / min
Max. acceleration	30 m / s ²
Max. no. of cycles	10 million
max. horizontal length	20 m
max. vertical length	5 m
Max. tensile load	20 N / mm ²
Operating temperature	-10 to 80 °C
Standards and features	
UL AWM listed	80 °C – 1000 V
CSA AWM listed	75 °C – 1000 V
VDE (U ₀ / U)	0.6 / 1 kV
Flame resistance	DIN EN 50265-2-1
Oil resistance	UL 1581
Silicone-free	yes
CFC-free	yes
Halogen-free	yes
Sheath	
Material	TMPU, halogen-free, compliant with UL AWM & CSA AWM
Shielding	tinned copper braid, optical cover ≥ 85%
Separator	Polyester strap
Colour	RAL 2003 (orange)
Power leads	4 x 1.5 mm ²
Conductor material	blank copper cl.5 (DIN EN 60228; VDE 0295; IEC 60228)
Insulation	TEO Flexene ® polymer compound, compliant with UL AWM & CSA AWM
Colour code	black (1 -3) + green/yellow
Signal leads	2 x (2 x 0.75 mm ²)
Conductor material	blank copper cl. 5 (DIN EN 60228; VDE 0295; IEC 60228)
Insulation	TEO Flexene ® polymer compound, compliant with UL AWM & CSA AWM

Structure	pair-wise twisted
Shielding per pair	tinned copper sheath, optical cover $\geq 85\%$
Separator	fleece tape
Colour code for signal pairs	2 pairs
1 st pair	black and black (5-6)
2 nd pair	black and black (7-8)
Electrical specifications	
Test conditions	20 °C
Test voltage for power leads (conductor/conductor - conductor/shielding) Test voltage for signal leads (conductor/conductor - conductor/shielding) Requirement	4 kV eff. 5 min. 2 kV eff. 1 min. undamaged insulation
Operating voltage	≤ 1000 V
Conductor resistance	IEC 60228 Cl.5
Insulation resistance	≥ 2500 MOhm x km
<u>Capacitance:</u> Power Signals	max. 150 pF / m max. 100 pF / m

Encoder cable

Specification	Encoder cable 7x(2x0.14mm ²)+1x(2x0.5mm ²)	Reserved
General data		
Weight	kg / km	
Min. bending radius	53 mm	
Overall diameter	7.6 mm \pm 0.3 mm	
Max. velocity	240 m / min	
Max. acceleration	30 m / s ²	
Max. no. of cycles	10 million	
max. horizontal length	20 m	
max. vertical length	5 m	
Max. tensile load	20 N/mm ²	
Operating temperature	-10 to 80 °C	
Standards and features		
UL AWM listed	80 °C – 30 V	
CSA AWM listed	75 °C – 30 V	
Flame resistance	DIN EN 50265-2-1	
Oil resistance	UL 1581	
Silicone-free	yes	
CFC-free	yes	
Halogen-free	yes	
Sheath		
Material	TMPU, halogen-free, compliant with UL AWM & CSA AWM	
Shielding	tinned copper braid, optical cover $\geq 85\%$	
Separator	Polyester strap	
Colour	RAL 6018 (green)	
Signal leads	7 x (2 x 0.14 mm ²)	
Conductor material	tinned copper 7 x 0.16 mm	
Conductor resistance	≤ 140 Ohm / km	
Insulation	polypropylene compliant with UL AWM & CSA AWM	
Structure	pair-wise twisted	

Colour code for signal pairs	8 pairs	
1 st pair	brown and white	
2 nd pair	green and yellow	
3 rd pair	grey and pink	
4 th pair	red and blue	
5 th pair	black and violet	
6 th pair	grey/pink and red/blue	
7 th pair	white/green and brown/green	
8 th pair	white/yellow and yellow/brown	
Electrical specifications		
Test conditions	20 °C	
Test voltage (conductor/conductor - conductor/shielding) Requirement	1500 VDC undamaged insulation	
Operating voltage	≤ 30 V	
Conductor material	2 x 0.5 mm ² , tinned copper	19 x 0.18 mm
Conductor resistance	≤ 40 Ohm / km	
Insulation resistance	min. 2500 MOhm x km	
Capacitance:		
Power	max. 100 pF / m	
Signals	max. 120 pF / m	

8.2.2 AX2000 and AX2500

All cables are specified for flexible routing. They enable highly dynamic operation and are UL-listed.

Motor cable with signal line

Specification	AX2000 4 x 1.5 mm ² + 2 x 1 mm ²	AX2500 4 x 1 mm ² + 2 x 1 mm ²
General data		
Min. bending radius	118 mm	115 mm
Weight	185 kg / km	155 kg / km
Overall diameter	10.6 mm ± 4 %	10 mm ± 4 %
Max. velocity	120 m / min	
Max. acceleration	4 m / s ²	
Max. no. of cycles	10 million	
Max. tensile load static / dynamic	50 / 20 N / mm ²	
Operating temperature	0 to 80 °C	
Oil resistance	"VDE 0472 Part 803 B"; "VDE 0282 Part 10"; "UL 1581"	
Sheath		
Material	PUR according to the UL standard	
Shielding	tinned copper braid, optical cover ≥ 85%	
Colour	RAL 2003 (orange)	
Power leads	4 x 1.5 mm ²	4 x 1 mm ²
Conductor material	blank copper (DIN EN 60228; VDE 0295; IEC 60228)	
Insulation	polyolefin polymer according to the UL standard	
Signal leads	2 x 1 mm ²	
Conductor material	blank copper (DIN EN 60228; VDE 0295; IEC 60228)	
Insulation	polyolefin polymer according to the UL standard	
Shielding	tinned copper sheath, optical cover ≥ 85%	
Electrical specifications		

Test conditions	20 °C
Test voltage for power leads (conductor/conductor - conductor/shielding)	3 kV eff.
Test voltage for signal leads (conductor/conductor - conductor/shielding)	1.5 kV 5 min. undamaged insulation
Test period	
Requirement	
Operating voltage	≤ 1000 V
Conductor resistance	
Signal leads	20.5 Ohm / km
Shielding resistance	
Signal leads	50 Ohm / km
Insulation resistance	
Power leads	min. 5000 MOhm x km
Signal leads	min. 20 MOhm x km
Capacitance	
Power leads	max. 120 pF / m
Signal leads	max. 150 pF / m

Encoder and resolver cable

Specification	Encoder cable 8 x 2 x 0.14 mm ²	Resolver cable 4 x 2 x 0.25 mm ²
General data		
Weight	69 kg / km	80 kg / km
Min. bending radius	75 mm	
Overall diameter	7.5 mm +/- 4%	
Max. velocity	120 m / min	
Max. acceleration	4 m / s ²	
Max. no. of cycles	10 million	
Max. tensile load static / dynamic	50 / 20 N / mm ²	
Operating temperature	0 to 80 °C	
Oil resistance	"VDE 0472 Part 803 B"; "VDE 0282 Part 10"; "UL 1581"	
Sheath		
Material	PUR according to the UL standard	
Shielding	tinned copper braid, optical cover ≥ 85%	
Colour	RAL 6018 (green)	
Signal leads	8 x 2 x 0.14 mm ²	4 x 2 x 0.25 mm ²
Conductor material	blank copper (DIN EN 60228; VDE 0295; IEC 60228)	
Insulation	polyolefin polymer according to the UL standard	
Structure	pair-wise twisted	
Colour code for signal pairs	8 pairs	4 pairs
1 st pair	brown and white	
2 nd pair	green and yellow	
3 rd pair	grey and pink	
4 th pair	red and blue	
5 th pair	black and violet	---
6 th pair	grey/pink and red/blue	---
7 th pair	white/green and brown/green	---
8 th pair	white/yellow and yellow/brown	---
Electrical specifications		
Test conditions	20 °C	

Test voltage for signal leads (conductor/conductor - conductor/shielding) Test period Requirement	1.5 kV eff. 5 min. undamaged insulation
Operating voltage	300 V
Insulation resistance Signal leads	min. 5000 MOhm x km
Capacitance	max. 120 pF / m

8.3 AX5000 connection diagram for motors with EnDAT / BiSS encoder

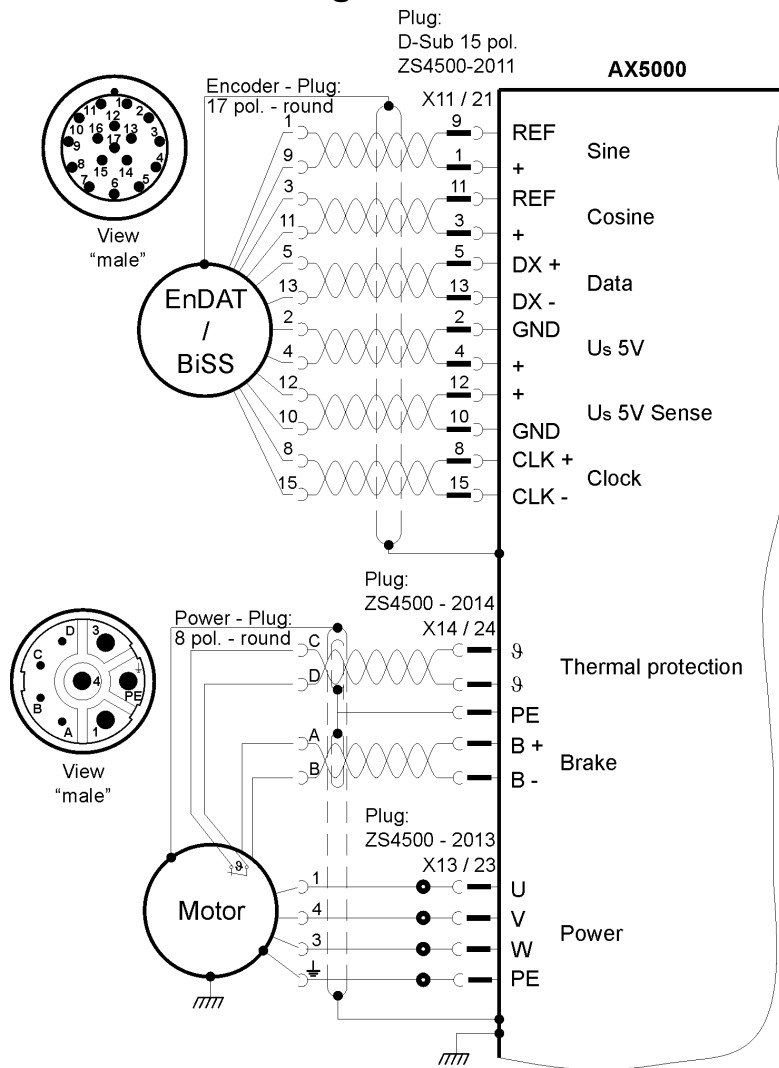

Thermal protection contact and brake

Power connector
8-poles, round

Motor cable
ZK4500-xxxx-xxxx



Power

Encoder connector
17-poles, round

Encoder cable
ZK4510-xxxx-xxxx

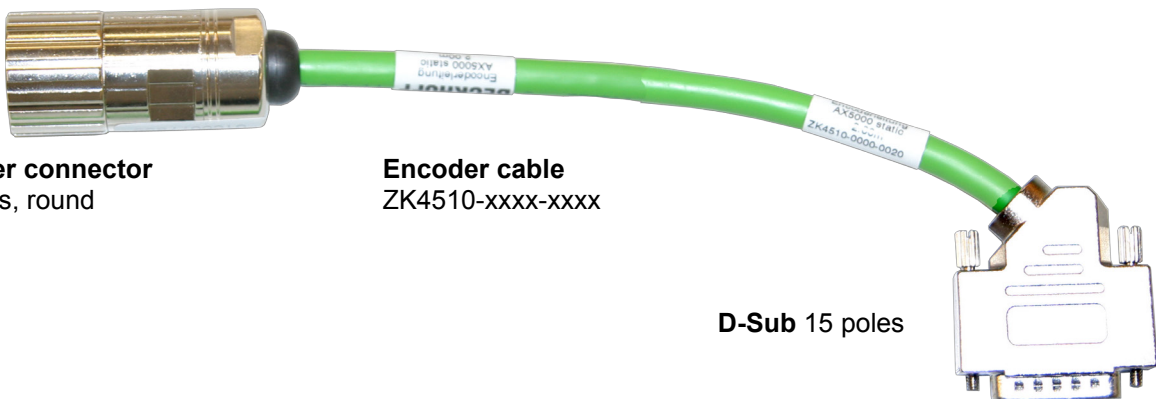

D-Sub 15 poles

8.4 AX5000 connection diagram for motors with resolver

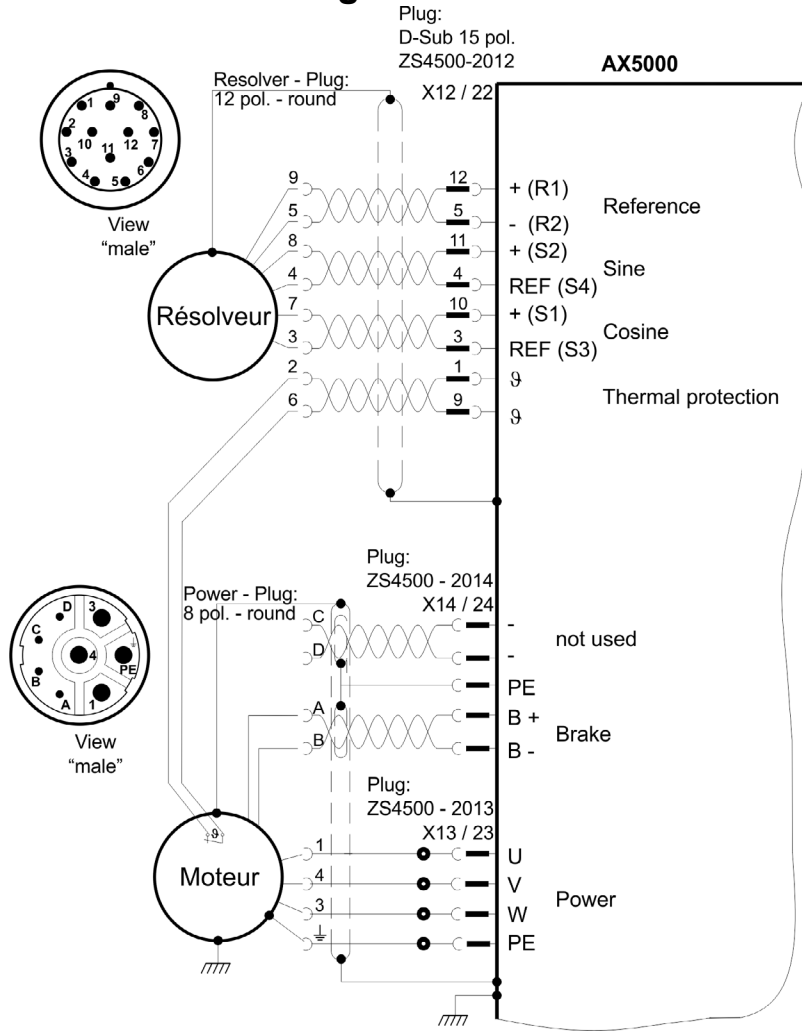

Thermal protection contact and brake

Power connector
8-poles, round

Motor cable
ZK4500-xxxx-xxxx



Power

Resolver connector
12-poles, round

Resolver cable
ZK4530-xxxx-xxxx

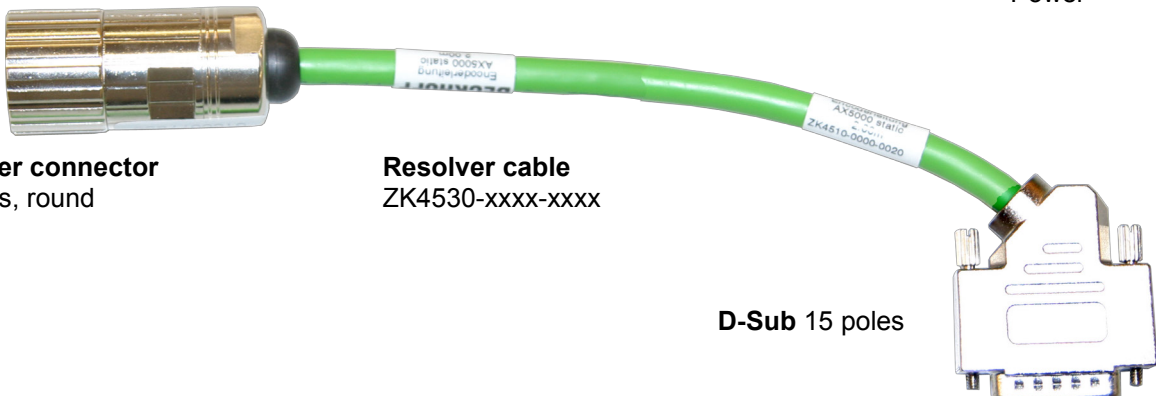

D-Sub 15 poles

8.5 AX5000 connection diagram for motors with resolver and yTec-Plug

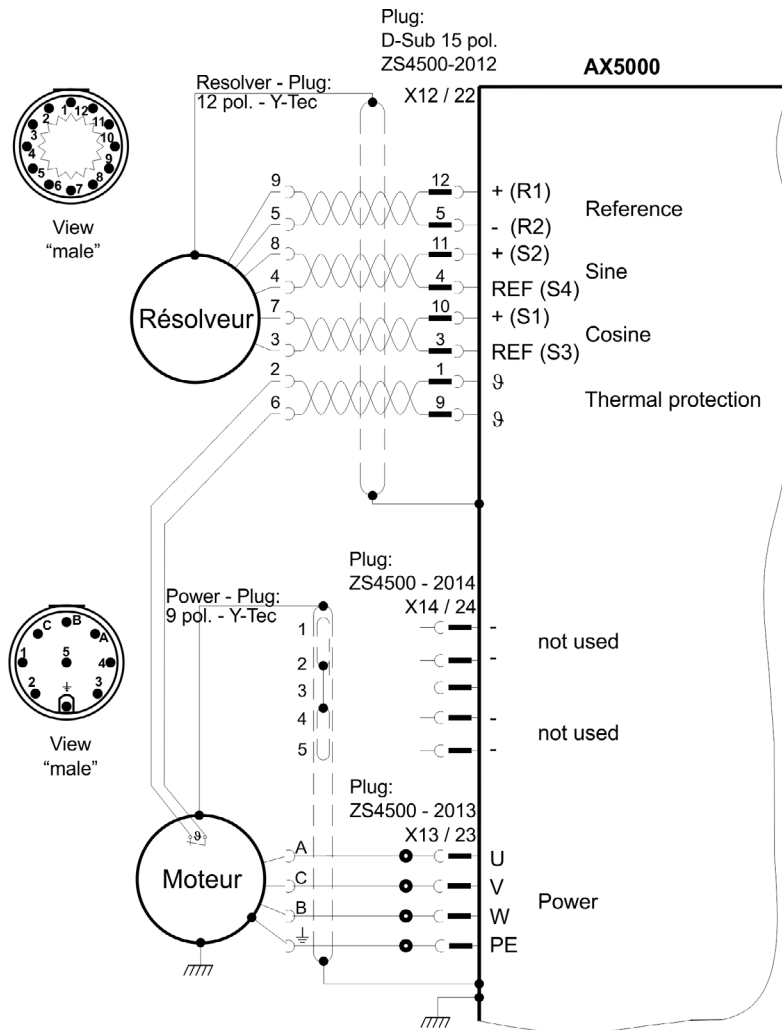

Power connector
9 pol. - yTec

Motor cable
ZK4500-0211-xxxx



Resolver connector
12 pol. - yTec

Resolver cable
ZK4530-xxxx-xxxx

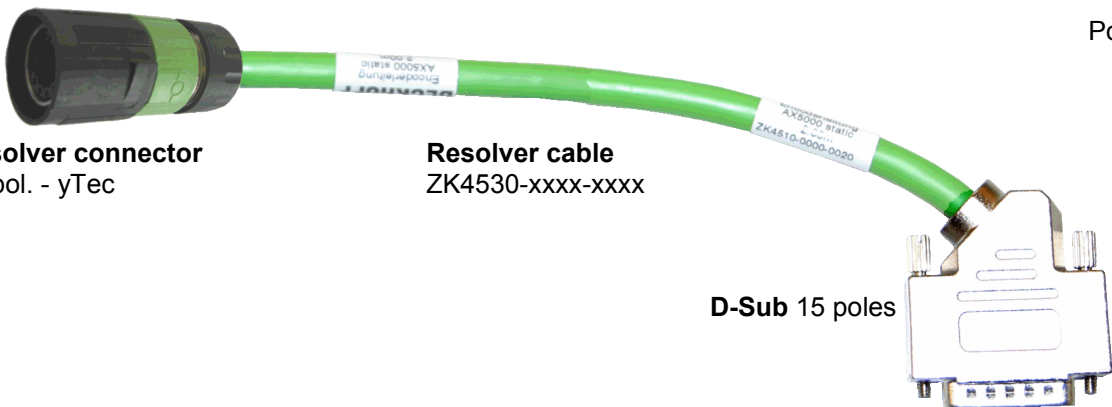

D-Sub 15 poles

8.6 AX2000 connection diagram for motors with EnDAT / BiSS encoder

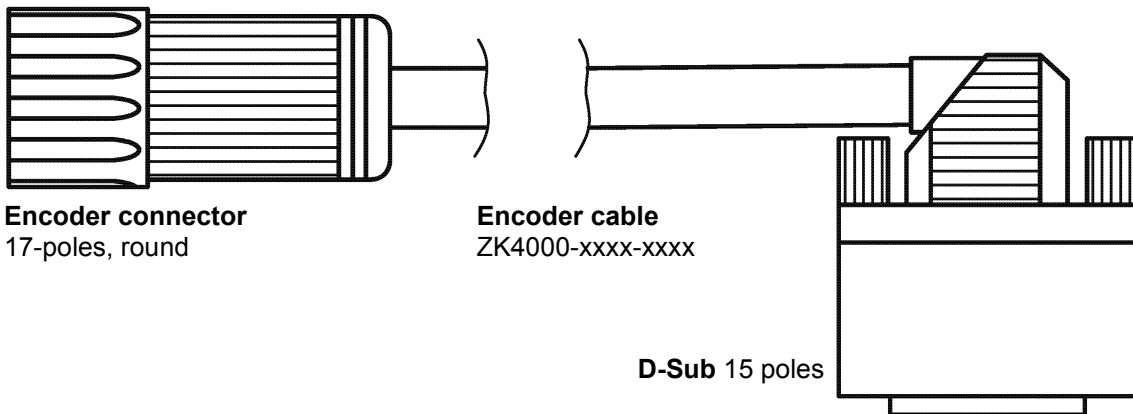
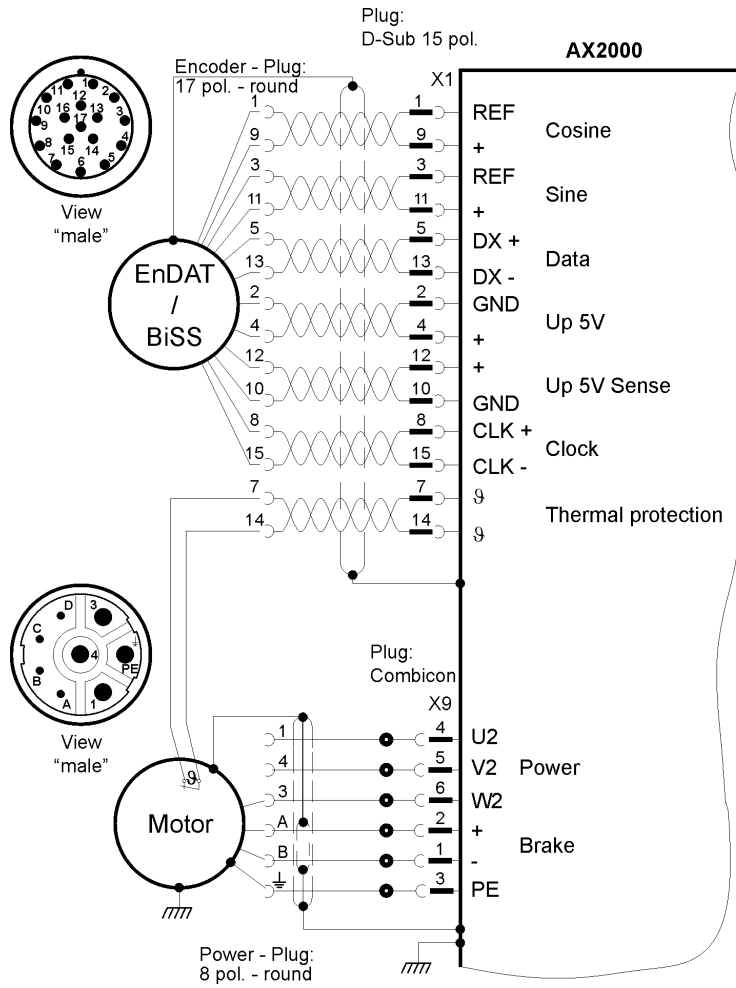

8.7 AX2000 connection diagram for motors with resolver

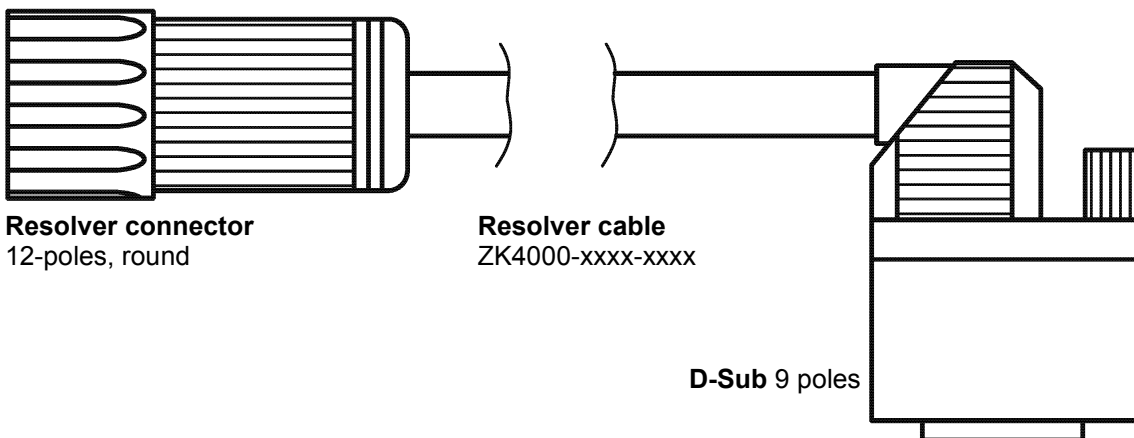
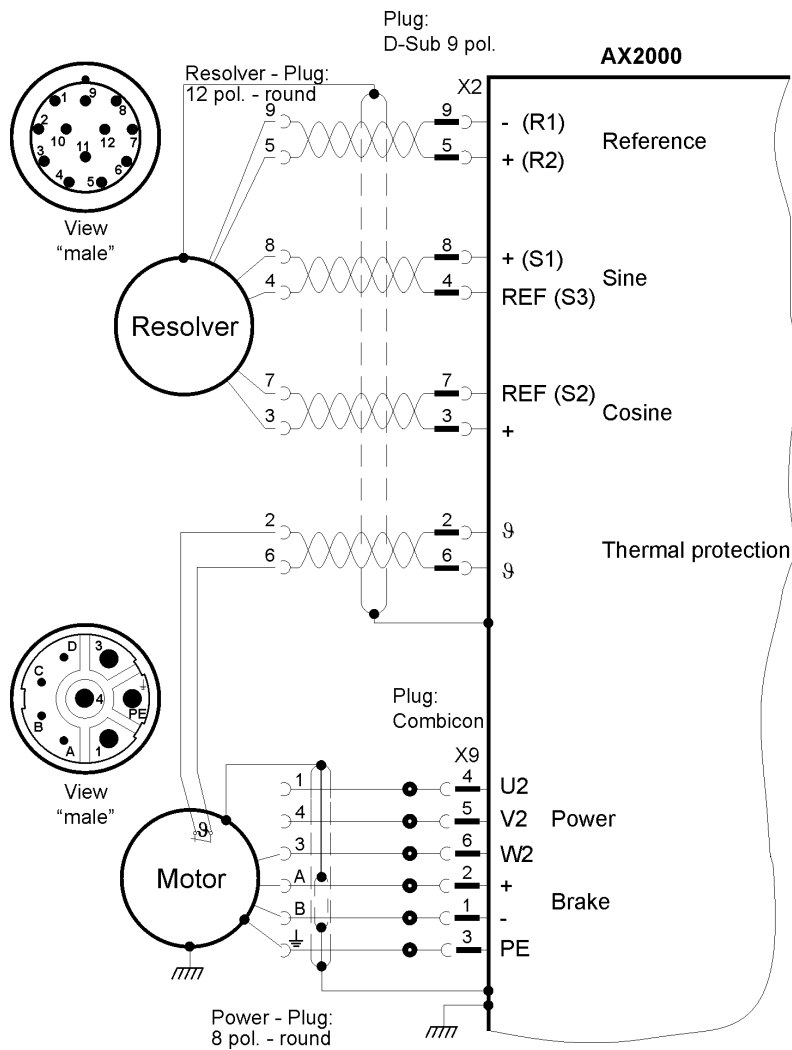

9 Commissioning

9.1 Important notes

 DANGER	<p>Serious risk of injury!</p> <ul style="list-style-type: none"> • Only specialist personnel with extensive knowledge in the areas of electrical engineering / drive technology are allowed to install and commission the equipment. • Check that all live connection points are protected against accidental contact. Dangerous voltages can occur, up to 900 V. • Never undo the electrical connections to the motor when it is live. The residual charge in the capacitors of the servo drives can produce dangerous voltages up to 5 minutes after the mains supply has been switched off. • The surface temperature of the motor can exceed 100 °C in operation. Check (measure) the temperature of the motor. Wait until the motor has cooled down below 40 °C before touching it. • Make sure that, even if the drive starts to move unintentionally, no danger can result for personnel or machinery.
--	--

9.2 Guide for commissioning

The procedure for commissioning is described as an example.

A different method may be appropriate or necessary, depending on the application of the equipment.

- Check the assembly and orientation of the motor.
- Check the drive components (coupling, gear unit, pulley) for the correct seating and setting (observe the permissible radial and axial forces).
- Check the wiring and connections to the motor and the servo drive. Check that the earthing is correct.
- Test the function of the holding brake, if used. (apply 24 V, the brake must be released).
- Check whether the rotor of the motor revolves freely (release the brake, if necessary). Listen out for grinding noises.
- Check that all the required measures against accidental contact with live and moving parts have been carried out.
- Carry out any further tests which are specifically required for your system.
- Now commission the drive according to the commissioning instructions for the servo drive.
- In multi-axis systems, individually commission each drive unit (servo drive/motor(s)).

9.3 Troubleshooting

The following table is to be seen as a “First Aid” box. There can be a large number of different reasons for a fault, depending on the particular conditions in your system. The fault causes described below are mostly those which directly influence the motor. Peculiarities which show up in the control behaviour can usually be traced back to an error in the parameterisation of the servo drive. The documentation for the servo drive and the commissioning software provides information on these matters.

For multi-axis systems there may be further hidden reasons for faults.

Our applications department can give you further help with your problems.

Fault	Possible cause	Measures to remove the cause of the fault
Motor doesn't rotate	<ul style="list-style-type: none"> • Servo drive not enabled • Break in setpoint lead • Motor phases in wrong sequence • Brake not released • Drive is mechanically blocked 	<ul style="list-style-type: none"> • Supply ENABLE signal • Check setpoint lead • Correct the phase sequence • Check brake control • Check mechanism
Motor runs away	<ul style="list-style-type: none"> • Motor phases in wrong sequence 	<ul style="list-style-type: none"> • Correct the phase sequence
Motor oscillates	<ul style="list-style-type: none"> • Break in the shielding of the feedback cable • Amplification to high 	<ul style="list-style-type: none"> • Replace feedback cable • Use motor default values
Error message: brake	<ul style="list-style-type: none"> • Short-circuit in the supply voltage lead to the motor holding brake • Faulty motor holding brake 	<ul style="list-style-type: none"> • Remove the short circuit • Replace motor
Error message: output stage fault	<ul style="list-style-type: none"> • Motor cable has short circuit or earth leakage • Motor has short circuit or earth leakage 	<ul style="list-style-type: none"> • Replace motor cable • Replace motor
Error message: feedback	<ul style="list-style-type: none"> • Connector is not properly plugged in • Break in cable, cable crushed or similar 	<ul style="list-style-type: none"> • Check connector • Check cables
Error message: motor temperature	<ul style="list-style-type: none"> • Motor thermostat has switched • Loose connector or break in cable 	<ul style="list-style-type: none"> • Wait until the motor has cooled down. Then investigate why the motor becomes so hot. • Check connector, replace cable if necessary
Brake does not grip	<ul style="list-style-type: none"> • Required holding torque too high • Brake faulty 	<ul style="list-style-type: none"> • Check the dimensioning • Replace motor

10 Technical data

All data valid for 40 °C ambient temperature and 100 K overtemperature of the winding.
The data can have a tolerance of +/- 10%.

10.1 Term definitions

Standstill torque M_0 [Nm]

The standstill torque can be maintained indefinitely at a speed $n < 100$ rpm and rated ambient conditions.

Rated torque M_n [Nm]

The rated torque is produced when the motor is drawing the rated current at the rated speed.
The rated torque can be produced indefinitely at the rated speed in continuous operation (S1).

Standstill current I_{0rms} [A]

The standstill current is the effective sinusoidal current which the motor draws at $n < 100$ rpm to produce the standstill torque.

Peak current (pulse current) I_{0max} [A]

The peak current (effective sinusoidal value) is approximately equivalent to 4-times the rated standstill current.
The peak current of the servo drive used must be smaller.

Torque constant K_{Trms} [Nm/A]

The torque constant defines how much torque in Nm is produced by the motor with 1A r.m.s. current. The relationship is $M = I \times K_T$ (up to $I = 2 \times I_0$)

Voltage constant K_{Erms} [mVmin]

The voltage constant defines the induced motor EMF, as an effective sinusoidal value between two terminals, per 1000 rpm.

Rotor moment of inertia J [kgcm²]

The constant J is a measure of the acceleration capability of the motor. For instance, at I_0 the acceleration time t_b from 0 to 3000 rpm is given as:

$$t_b [S] = \frac{3000 \times 2\pi}{M_0 \times 60s} \times \frac{m^2}{10^4 \text{ cm}^2} \times J \quad \text{with } M_0 \text{ in Nm and } J \text{ in kgcm}^2$$

Thermal time constant t_{TH} [min]

The constant t_{TH} defines the time for the cold motor, under a load of I_0 to heat up to an overtemperature of 0.63 x 100 Kelvin.

This temperature rise happens in a much shorter time when the motor is loaded with the peak current.

Release delay time t_{BRH} [ms] / Application delay time t_{BRL} [ms] of the brake

These constants define the response times of the holding brake when operated with the rated voltage from the servo drive.

10.2 AM301x

Technical data		Symbol [Unit]	AM30xx						
			11B	11C	11E	12C	12E	13C	13D
Electrical data									
	Standstill torque *	M_0 [Nm]	0.18	0.18	0.18	0.31	0.31	0.41	0.40
	Standstill current	I_{orms} [A]	1.16	1.45	2.91	1.51	2.72	1.48	2.40
	Max. mechanical speed	N_{max} [min ⁻¹]	8000						
	Max. rated mains voltage	U_N [VAC]	230VAC						
$U = 115V$	Rated speed	N_n [min ⁻¹]	4000	6000	-	4000	8000	3000	7000
	Rated torque *	M_n [Nm]	0.18	0.18	-	0.30	0.28	0.41	0.36
	Rated output	P_n [kW]	0.08	0.11	-	0.13	0.23	0.13	0.27
$U_N = 230V$	Rated speed	N_n [min ⁻¹]	8000	-	-	8000	-	8000	-
	Rated torque *	M_n [Nm]	0.17	-	-	0.28	-	0.36	-
	Rated output	P_n [kW]	0.14	-	-	0.23	-	0.30	-
$U_N = 400V$	Rated speed	N_n [min ⁻¹]	-	-	-	-	-	-	-
	Rated torque *	M_n [Nm]	-	-	-	-	-	-	-
	Rated output	P_n [kW]	-	-	-	-	-	-	-
$U_N = 480V$	Rated speed	N_n [min ⁻¹]	-	-	-	-	-	-	-
	Rated torque *	M_n [Nm]	-	-	-	-	-	-	-
	Rated output	P_n [kW]	-	-	-	-	-	-	-
	Peak current	I_{0max} [A]	5.8	7.3	14.6	7.6	13.6	7.4	12.0
	Peak torque	M_{0max} [Nm]	0.708	0.718	0.712	1.27	1.24	1.73	1.72
	Torque constant	K_{Trms} [Nm/A]	0.16	0.13	0.06	0.21	0.11	0.28	0.17
	Voltage constant	$K_{E rms}$ [mV/min]	10.2	8.3	4.1	13.3	7.2	17.9	10.9
	Winding resistance Ph-PH	R_{25} [Ω]	18.2	12.1	3.1	12.4	3.9	13.5	5.4
	Winding inductance Ph-Ph	L [mH]	12.5	8.3	2.0	9.1	2.7	10.3	3.8

Mechanical data		AM3011	AM3012	AM3013
Rotor moment of inertia	J [kgcm ²]	0.017	0.031	0.045
Pole number		6	6	6
Static friction torque	M_R [Nm]	0.0011	0.0021	0.0031
Thermal time constant	t_{TH} [min]	4	6	7
Weight, standard	G [kg]	0.35	0.49	0.63
Permitted radial force at shaft end	F_R [N]	30		
Permitted axial force	F_A [N]	12		

* reference flange aluminium 254mm x 254mm x 6.35mm

Options such as sealing ring, holding brake, EnDAT or BiSS lead to a reduction of the rated data.

Data for optional brake

Data	Symbol [Unit]	Value
Holding torque at 120 °C	M_{BR} [Nm]	0.41
Supply voltage	U_{BR} [VDC]	24 ± 10 %
Electrical power	P_{BR} [W]	6.4
Release delay time	t_{BRH} [ms]	60
Application delay time	t_{BRL} [ms]	30
Weight of the brake	G_{BR} [kg]	0.20
Moment of inertia	J_{BR} [kgcm ²]	0.004
Typical backlash	[° mech.]	0.53

10.2.1A Dimensional drawing

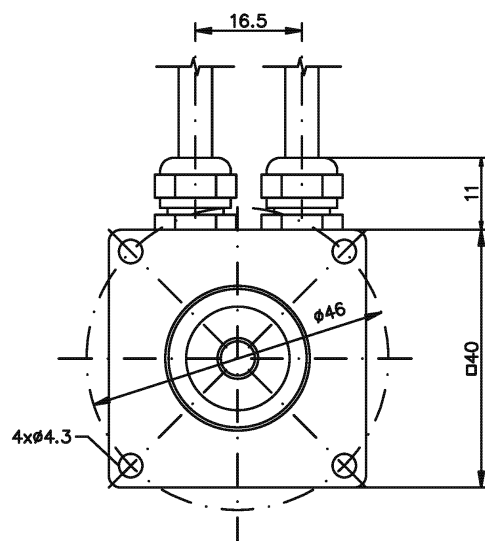
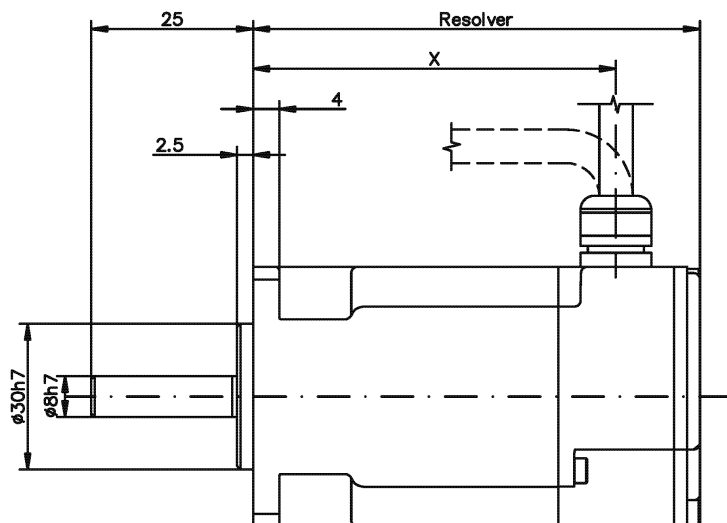

Motor type	X	Resolver
AM3011	56.1	69.6
AM3012	75.1	88.6
AM3013	94.1	107.6

Optional: Feather key

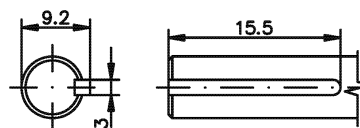

10.2.1B Dimensional drawing

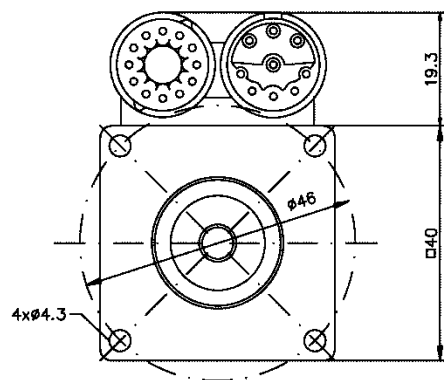
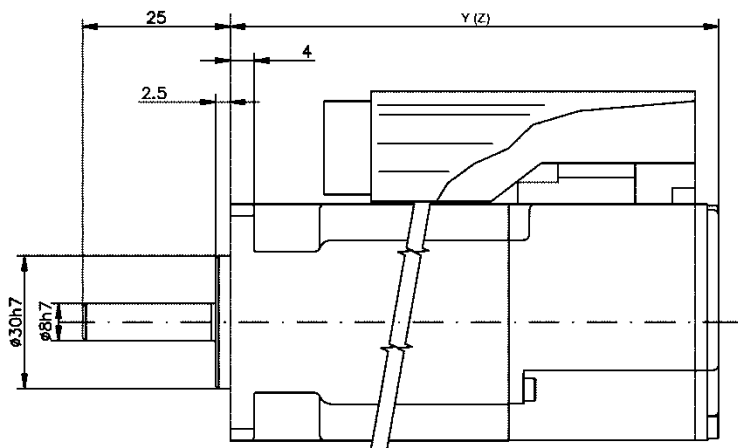

Motor type	Resolver		Encoder	
	Y	Z (Brake)	Y	Z (Brake)
AM3011	79	116	88,5	125,5
AM3012	98	135	107,5	144,5
AM3013	117	154	126,5	163,5

Optional: Feather key

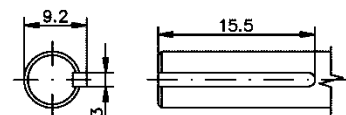

10.2.2 Radial / axial forces at the shaft end

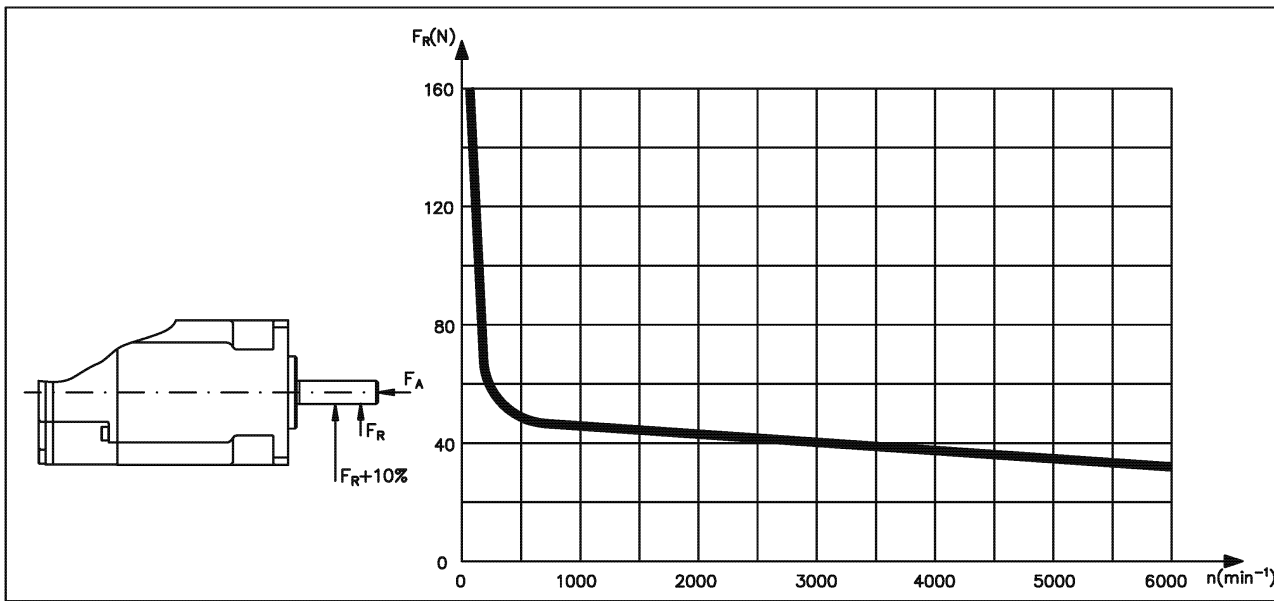

10.2.3 Characteristic torque / speed curves

Characteristic torque / speed curves can be found on the Beckhoff-website under [Drive Technology](#).

10.3 AM302x

Technical data		Symbol [Unit]	AM30xx											
			21C	21E	21G	22C	22E	22G	23C	23D	23F	24C	24D	24F
Electrical data														
	Standstill torque *	M_0 [Nm]	0.48	0.50	0.50	0.84	0.87	0.88	1.13	1.16	1.18	1.38	1.41	1.42
	Standstill current	I_{0rms} [A]	1.58	3.11	4.87	1.39	2.73	4.82	1.41	2.19	4.31	1.42	2.21	3.89
	Max. mechanical speed	N_{max} [min ⁻¹]	8000											
	Max. rated mains voltage	U_N [VAC]	480											
U = 115V	Rated speed	N_n [min⁻¹]	2500	7000	-	1000	3500	7000	1000	1500	4500	-	1500	3000
	Rated torque *	M_n [Nm]	0.46	0.41	-	0.83	0.81	0.74	1.11	1.12	1.07	-	1.36	1.33
	Rated output	P_n [kW]	0.12	0.30	-	0.09	0.30	0.54	0.12	0.18	0.50	-	0.21	0.42
U_N = 230V	Rated speed	N_n [min⁻¹]	8000	-	-	3500	8000	-	2500	5000	8000	2000	4000	8000
	Rated torque *	M_n [Nm]	0.39	-	-	0.78	0.70	-	1.08	1.03	0.94	1.32	1.29	1.12
	Rated output	P_n [kW]	0.32	-	-	0.29	0.59	-	0.28	0.54	0.79	0.28	0.54	0.94
U_N = 400V	Rated speed	N_n [min⁻¹]	-	-	-	8000	-	-	5500	8000	-	4500	8000	-
	Rated torque *	M_n [Nm]	-	-	-	0.68	-	-	0.99	0.92	-	1.25	1.11	-
	Rated output	P_n [kW]	-	-	-	0.57	-	-	0.57	0.77	-	0.59	0.93	-
U_N = 480V	Rated speed	N_n [min⁻¹]	-	-	-	8000	-	-	7000	8000	-	5500	8000	-
	Rated torque *	M_n [Nm]	-	-	-	0.68	-	-	0.95	0.92	-	1.22	1.11	-
	Rated output	P_n [kW]	-	-	-	0.57	-	-	0.70	0.77	-	0.70	0.93	-
	Peak current	I_{0max} [A]	7.9	15.6	24.4	7.0	13.7	24.1	7.1	11.0	21.6	7.1	11.1	19.5
	Peak torque	M_{0max} [Nm]	1.65	1.67	1.68	3.11	3.15	3.17	4.40	4.43	4.49	5.51	5.58	5.61
	Torque constant	K_{Trms} [Nm/A]	0.30	0.16	0.10	0.61	0.32	0.18	0.80	0.52	0.27	0.97	0.63	0.36
	Voltage constant	K_{Ems} [mV/min]	19.5	10.2	6.6	39	20.4	11.7	51.8	33.8	17.6	62.4	40.8	23.4
	Winding resistance Ph-PH	R_{25} [Ω]	13.0	3.42	1.44	20	5.22	1.69	21.2	8.77	2.34	20.4	9.02	2.77
	Winding inductance Ph-PH	L [mH]	19	5.2	2.18	35.5	9.7	3.19	40.7	17.3	4.68	43.8	18.7	6.16

* reference flange aluminium 254mm x 254mm x 6.35mm
Options such as sealing ring, holding brake, EnDAT or BiSS lead to a reduction of the rated data.

Mechanical data		AM3021	AM3022	AM3023	AM3024
Rotor moment of inertia	J [kgcm ²]	0.11	0.16	0.22	0.27
Pole number		6	6	6	6
Static friction torque	M_R [Nm]	0.002	0.005	0.007	0.01
Thermal time constant	t_{TH} [min]	8	9	10	11
Weight, standard	G [kg]	0.82	1.1	1.38	1.66
Permitted radial force at shaft end	F_R [N]	145			
Permitted axial force	F_A [N]	60			

Data for optional brake

Data	Symbol [Unit]	Value
Holding torque at 120 °C	M_{BR} [Nm]	1.42
Supply voltage	U_{BR} [VDC]	24 ± 10 %
Electrical power	P_{BR} [W]	8.4
Current	I_{on} [A]	0.35
Release delay time	t_{BRH} [ms]	20
Application delay time	t_{BRL} [ms]	18
Weight of the brake	G_{BR} [kg]	0.27
Moment of inertia	J_{BR} [kgcm ²]	0.011
Typical backlash	[° mech.]	0.46

10.3.1 Dimensional drawing

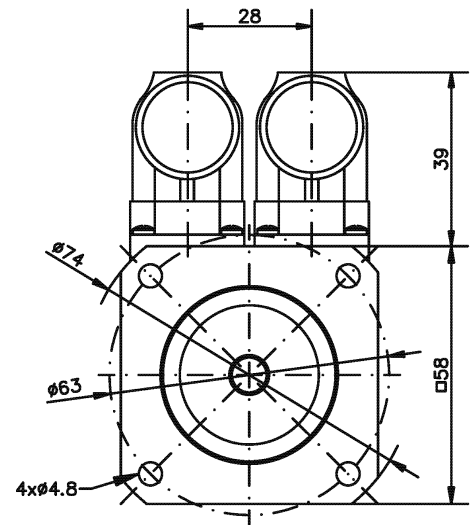
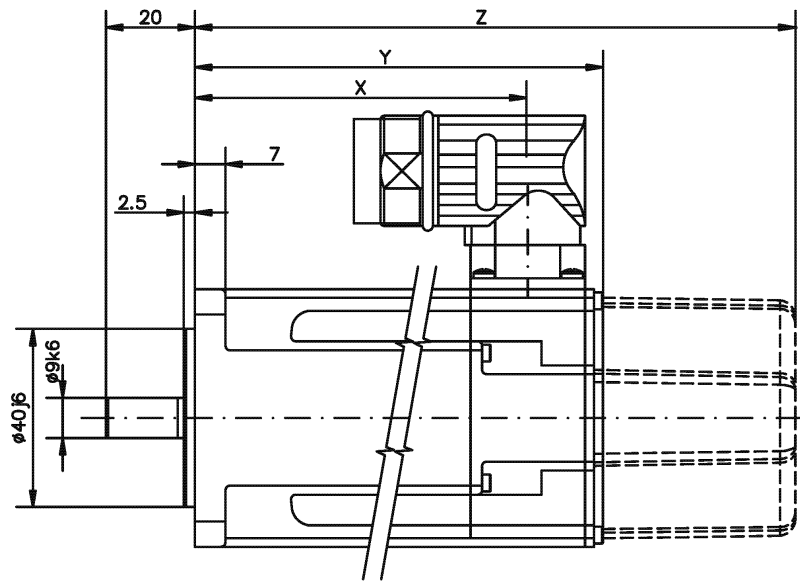

Motor type	X	Y	Z (brake)
AM3021	76.1	95.4	129.5
AM3022	95.1	114.4	148.5
AM3023	114.1	133.4	167.5
AM3024	133.1	152.4	186.5

Optional: Feather key

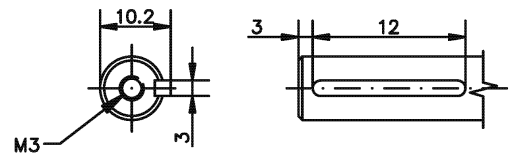

10.3.2 Radial / axial forces at the shaft end

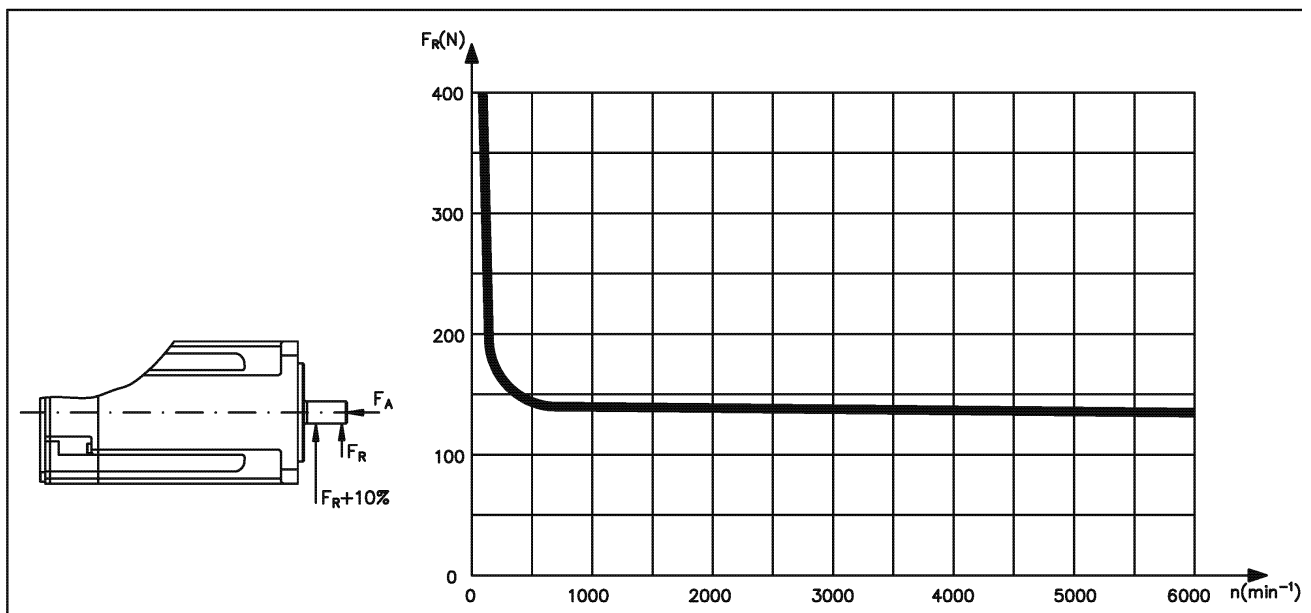

10.3.3 Characteristic torque / speed curves

Characteristic torque / speed curves can be found on the Beckhoff-website under [Drive Technology](#).

10.4 AM303x

Technical data		Symbol [Unit]	AM30xx								
			31C	31E	31H	32C	32D	32H	33C	33E	33H
Electrical data											
	Standstill torque *	M_0 [Nm]	1.15	1.20	1.23	2.00	2.04	2.10	2.71	2.79	2.88
	Standstill current	I_{orms} [A]	1.37	2.99	5.85	1.44	2.23	5.50	1.47	2.58	5.62
	Max. mechanical speed	N_{max} [min ⁻¹]	8000								
	Max. rated mains voltage	U_N [VAC]	480								
U = 115V	Rated speed	N_n [min⁻¹]	-	2500	6000	-	1000	3000	-	-	2500
	Rated torque *	M_n [Nm]	-	1.17	0.97	-	2.00	1.96	-	-	2.66
	Rated output	P_n [kW]	-	0.31	0.61	-	0.21	0.62	-	-	0.70
U_N = 230V	Rated speed	N_n [min⁻¹]	2500	6000	-	1500	2500	7000	1000	2000	5500
	Rated torque *	M_n [Nm]	1.12	0.95	-	1.95	1.93	1.45	2.64	2.62	2.27
	Rated output	P_n [kW]	0.29	0.60	-	0.31	0.51	1.06	0.28	0.55	1.31
U_N = 400V	Rated speed	N_n [min⁻¹]	5000	-	-	3000	5500	-	2000	4500	-
	Rated torque *	M_n [Nm]	1.00	-	-	1.86	1.65	-	2.54	2.34	-
	Rated output	P_n [kW]	0.52	-	-	0.58	0.95	-	0.53	1.10	-
U_N = 480V	Rated speed	N_n [min⁻¹]	6000	-	-	3500	6000	-	2500	5000	-
	Rated torque *	M_n [Nm]	0.91	-	-	1.83	1.58	-	2.5	2.27	-
	Rated output	P_n [kW]	0.57	-	-	0.67	0.99	-	0.65	1.19	-
	Peak current	I_{0max} [A]	6.9	15.0	29.3	7.2	11.2	27.5	7.4	12.9	28.1
	Peak torque	M_{0max} [Nm]	4.49	4.60	4.67	8.18	8.30	8.47	11.55	11.76	12.0
	Torque constant	K_{Trms} [Nm/A]	0.85	0.41	0.21	1.40	0.92	0.39	1.86	1.10	0.52
	Voltage constant	K_{Ems} [mV/min]	54.5	26.1	13.7	89.8	59.0	24.8	120	70.6	33.4
	Winding resistance Ph-PH	R_{25} [Ω]	21.4	4.74	1.29	23.8	10.3	1.69	26.6	9.01	1.96
	Winding inductance Ph-PH	L [mH]	37.5	8.6	2.4	46.5	20.1	3.55	53.6	18.5	4.1

* reference flange aluminium 254mm x 254mm x 6.35mm

Options such as sealing ring, holding brake, EnDAT or BiSS lead to a reduction of the rated data.

Mechanical data		AM3031	AM3032	AM3033
Rotor moment of inertia	J [kgcm ²]	0.33	0.59	0.85
Pole number		8	8	8
Static friction torque	M_R [Nm]	0.014	0.02	0.026
Thermal time constant	t_{TH} [min]	14	17	20
Weight, standard	G [kg]	1.55	2.23	2.9
Permitted radial force at shaft end	F_R [N]	195		
Permitted axial force	F_A [N]	65		

Data for optional brake

Data	Symbol [Unit]	Value
Holding torque at 120 °C	M_{BR} [Nm]	2.5
Supply voltage	U_{BR} [VDC]	24 ± 10 %
Electrical power	P_{BR} [W]	10.1
Current	I_{on} [A]	0.42
Release delay time	t_{BRH} [ms]	25
Application delay time	t_{BRL} [ms]	10
Moment of inertia	J_{BR} [kgcm ²]	0.011
Weight of the brake	G_{BR} [kg]	0.35
Typical backlash	[° mech.]	0.46

10.4.1 Dimensional drawing

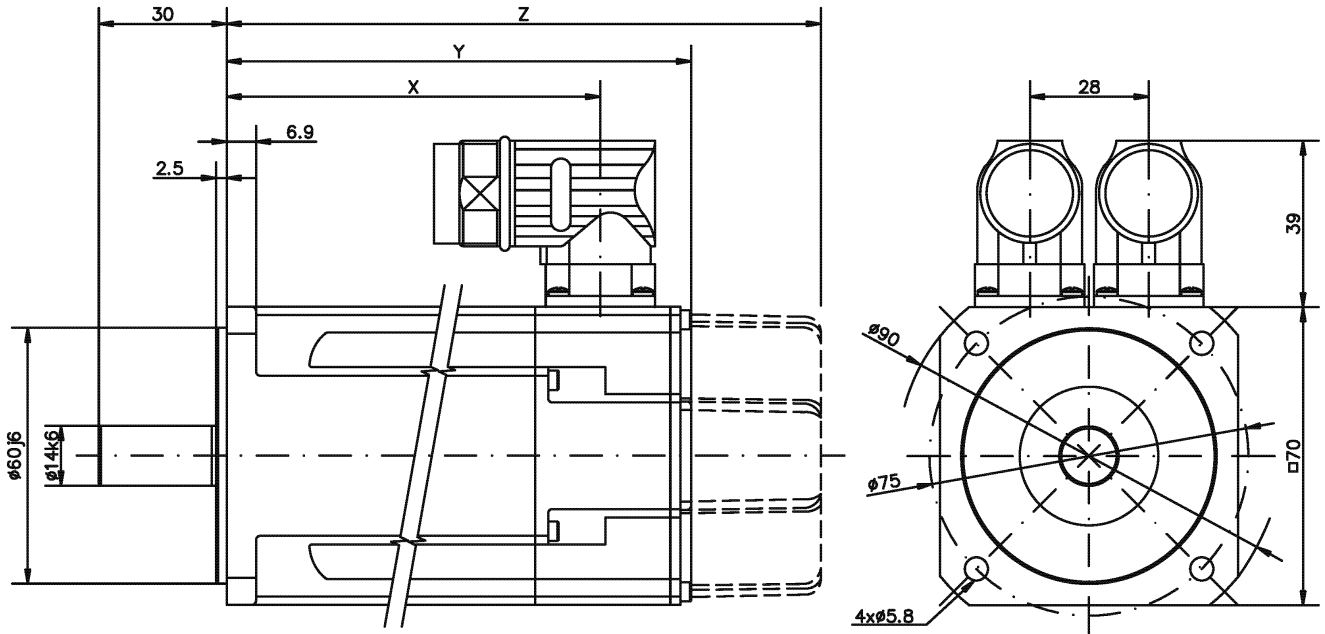

Motor type	X	Y	Z (brake)
AM3031	87,9	109,8	141,3
AM3032	118,9	140,8	172,3
AM3033	149,9	171,8	203,3

Optional: Feather key

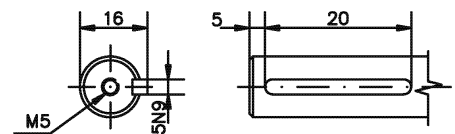

10.4.2 Radial / axial forces at the shaft end

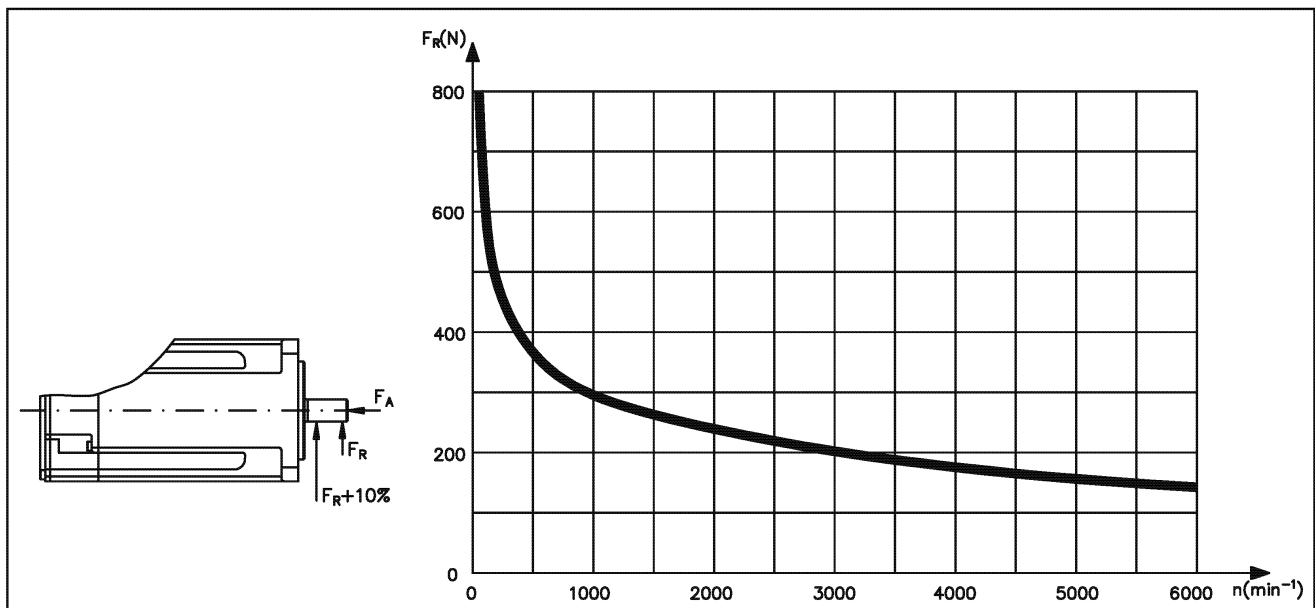

10.4.3 Characteristic torque / speed curves

Characteristic torque / speed curves can be found on the Beckhoff-website under [Drive Technology](#).

10.5 AM304x

Technical data		Symbol [Unit]	AM30xx														
			41C	41E	41H	42C	42E	42G	42J	43E	43G	43H	43K	44E	44G	44H	44J
Electrical data																	
	Standstill torque *	M ₀ [Nm]	1.95	2.02	2.06	3.35	3.42	3.53	3.56	4.70	4.80	4.82	4.90	5.76	5.88	5.89	6.00
	Standstill current	I _{orms} [A]	1.46	2.85	5.60	1.40	2.74	4.80	8.40	2.76	4.87	5.4	9.60	2.90	5.00	5.6	8.80
	Max. mechanical speed	N _{max} [min ⁻¹]	6000														
	Max. rated mains voltage	U _N [VAC]	480														
U = 115V	Rated speed	N _n [min ⁻¹]	-	1200	3000	-	-	-	3000	-	-	-	2500	-	-	-	-
	Rated torque *	M _n [Nm]	-	1.94	1.86	-	-	-	3.03	-	-	-	4.08	-	-	-	-
	Rated output	P _n [kW]	-	0.24	0.58	-	-	-	0.95	-	-	-	1.07	-	-	-	-
U _N = 230V	Rated speed	N _n [min ⁻¹]	1200	3000	6000	-	1800	3500	6000	1500	2500	3000	6000	1200	2000	2500	4000
	Rated torque *	M _n [Nm]	1.88	1.82	1.62	-	3.12	2.90	2.38	4.24	4.0	3.86	2.62	5.22	4.90	4.66	3.84
	Rated output	P _n [kW]	0.24	0.57	1.02	-	0.59	1.06	1.50	0.67	1.05	1.21	1.65	0.66	1.03	1.22	1.61
U _N = 400V	Rated speed	N _n [min ⁻¹]	3000	6000	-	1500	3500	6000	-	2500	5000	6000	-	2000	4000	5000	6000
	Rated torque *	M _n [Nm]	1.77	1.58	-	3.10	2.81	2.35	-	3.92	3.01	2.58	-	4.80	3.76	3.19	2.75
	Rated output	P _n [kW]	0.56	0.99	-	0.49	1.03	1.48	-	1.03	1.58	1.62	-	1.01	1.57	1.67	1.73
U _N = 480V	Rated speed	N _n [min ⁻¹]	3500	6000	-	2000	4000	6000	-	3000	6000	-	-	2500	5000	6000	6000
	Rated torque *	M _n [Nm]	1.74	1.58	-	3.02	2.72	2.35	-	3.76	2.57	-	-	4.56	3.19	2.7	2.75
	Rated output	P _n [kW]	0.64	0.99	-	0.63	1.14	1.48	-	1.18	1.61	-	-	1.19	1.67	1.67	1.73
	Peak current	I _{0max} [A]	7.3	14.3	28.0	7.0	13.7	24.0	42.0	13.8	24.4	27.2	48.0	14.5	25.0	28.1	44.0
	Peak torque	M _{0max} [Nm]	7.02	7.15	7.20	12.81	13.0	13.24	13.33	18.5	18.8	18.9	19.0	23.7	23.7	23.7	24.0
	Torque constant	K _{Trms} [Nm/A]	1.34	0.71	0.37	2.40	1.26	0.74	0.43	1.72	0.99	0.89	0.52	2.04	1.19	1.06	0.69
	Voltage constant	K _{Ems} [mV/min]	86.3	45.6	23.7	154	80.9	47.5	27.5	111	63.9	57.4	33.2	132	76.6	68.0	44.2
	Winding resistance Ph-PH	R ₂₅ [Ω]	21.3	6.02	1.56	27.5	7.78	2.51	0.80	8.61	2.61	2.1	0.74	8.08	2.80	2.23	0.94
	Winding inductance Ph-PH	L [mH]	66.1	18.4	5.0	97.4	26.8	9.2	3.1	32.6	10.8	8.8	2.9	33.9	11.5	9.1	3.8

* reference flange aluminium 254mm x 254mm x 6.35mm
Options such as sealing ring, holding brake, EnDAT or BiSS lead to a reduction of the rated data.

Mechanical data		AM3041	AM3042	AM3043	AM3044
Rotor moment of inertia	J [kgcm ²]	0.81	1.5	2.1	2.7
Pole number		10	10	10	10
Static friction torque	M _R [Nm]	0.014	0.026	0.038	0.05
Thermal time constant	t _{TH} [min]	13	17	20	24
Weight, standard	G [kg]	2.44	3.39	4.35	5.3
Permitted radial force at shaft end	F _R [N]	450			
Permitted axial force	F _A [N]	180			

Data for optional brake

Data	Symbol [Unit]	Value
Holding torque at 120 °C	M _{BR} [Nm]	6
Supply voltage	U _{BR} [VDC]	24 ± 10 %
Electrical power	P _{BR} [W]	12.8
Current	I _{on} [A]	0.53
Release delay time	t _{BRH} [ms]	35
Application delay time	t _{BRL} [ms]	15
Moment of inertia	J _{BR} [kgcm ²]	0.068
Weight of the brake	G _{BR} [kg]	0.63
Typical backlash	[°mech.]	0.37

10.5.1 Dimensional drawing

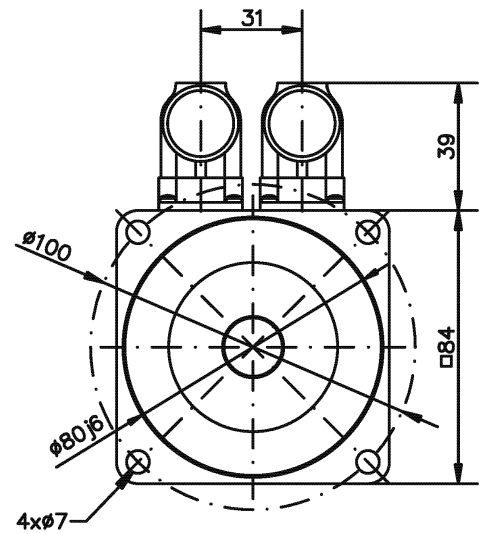
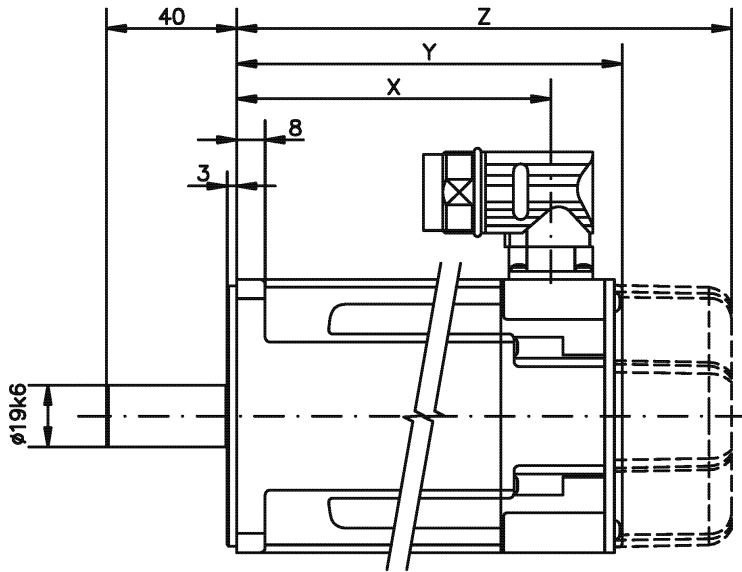

Motor type	X	Y	Z (brake)
AM3041	96,4	118,8	152,3
AM3042	125,5	147,8	181,3
AM3043	154,4	176,8	210,3
AM3044	183,4	205,8	239,3

Optional: Feather key

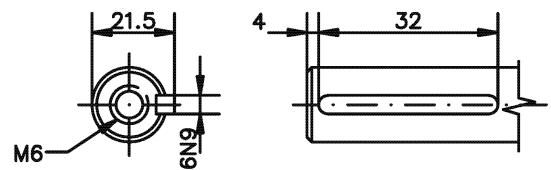

10.5.2 Radial / axial forces at the shaft end

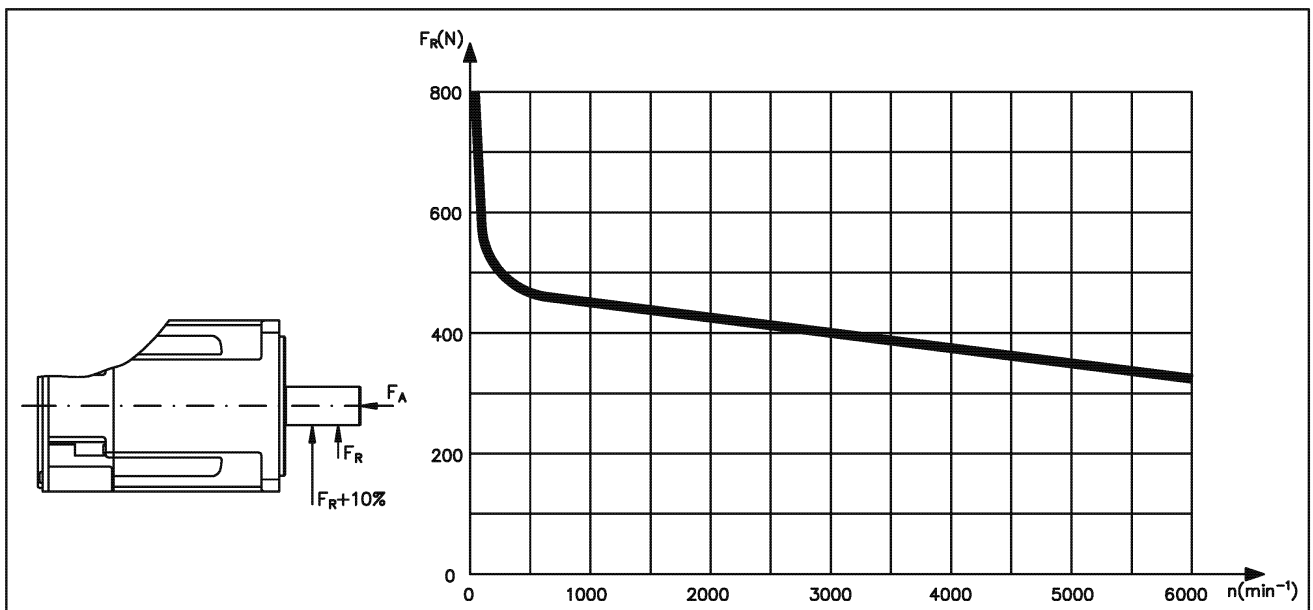

10.5.3 Characteristic torque / speed curves

Characteristic torque / speed curves can be found on the Beckhoff-website under [Drive Technology](#).

10.6A AM305x (AM3051; AM3052)

Technical data		Symbol [Unit]	AM30xx								
			51E	51G	51H	51K	52E	52G	52H	52K	52M
Electrical data											
	Standstill torque *	M_0 [Nm]	4.70	4.75	4.79	4.90	8.34	8.43	8.48	8.60	8.60
	Standstill current	I_{oms} [A]	2.75	4.84	6.0	9.4	2.99	4.72	5.9	9.3	13.1
	Max. mechanical speed	N_{max} [min^{-1}]	6000								
	Max. rated mains voltage	U_N [VAC]	480								
U = 115V	Rated speed	N_n [min^{-1}]	-	-	-	2500	-	-	-	-	-
	Rated torque *	M_n [Nm]	-	-	-	4.15	-	-	-	-	-
	Rated output	P_n [kW]	-	-	-	1.09	-	-	-	-	-
U_n = 230V	Rated speed	N_n [min^{-1}]	1200	2500	3000	5500	-	1500	1800	3000	4500
	Rated torque *	M_n [Nm]	4.41	4.02	3.87	2.35	-	7.69	7.53	6.80	5.20
	Rated output	P_n [kW]	0.55	1.05	1.22	1.35	-	1.21	1.42	2.14	2.45
U_n = 400V	Rated speed	N_n [min^{-1}]	2500	5000	6000	-	1500	2500	3500	5500	-
	Rated torque *	M_n [Nm]	3.98	2.62	1.95	-	7.61	7.06	6.26	3.90	-
	Rated output	P_n [kW]	1.04	1.37	1.23	-	1.20	1.85	2.3	2.25	-
U_n = 480V	Rated speed	N_n [min^{-1}]	3000	6000	6000	-	2000	3000	4000	6000	-
	Rated torque *	M_n [Nm]	3.80	1.94	1.95	-	7.28	6.66	5.77	3.25	-
	Rated output	P_n [kW]	1.19	1.22	1.23	-	1.52	2.09	2.42	2.04	-
	Peak current	I_{0max} [A]	13.8	24.2	30.0	47	15.0	23.6	29.5	46.5	65.5
	Peak torque	M_{0max} [Nm]	15.6	15.6	15.6	15.8	29.5	29.7	29.7	30.0	30.0
	Torque constant	K_{Tms} [Nm/A]	1.72	0.99	0.80	0.52	2.79	1.79	1.44	0.93	0.66
	Voltage constant	K_{Ems} [mV/min]	110	63.6	51.3	33.5	179	115	92.7	60.1	42.4
	Winding resistance Ph-PH	R_{25} [Ω]	8.98	2.75	1.97	0.75	8.96	3.70	2.35	0.96	0.49
	Winding inductance Ph-PH	L [mH]	36.6	12.1	7.9	3.40	44.7	18.5	11.9	5.00	2.50

* reference flange aluminium 305mm x 305mm x 12.7mm

Options such as sealing ring, holding brake, EnDAT or BiSS lead to a reduction of the rated data.

Mechanical data		AM3051	AM3052
Rotor moment of inertia	J [$kgcm^2$]	3.4	6.2
Pole number		10	10
Static friction torque	M_R [Nm]	0.022	0.04
Thermal time constant	t_{TH} [min]	20	24
Weight, standard	G [kg]	4.2	5.8
Permitted radial force at shaft end	F_R [N]	450	
Permitted axial force	F_A [N]	180	

Data for optional brake

Data	Symbol [Unit]	Value
Holding torque at 120 °C	M_{BR} [Nm]	14.5
Supply voltage	U_{BR} [VDC]	24 ± 10 %
Electrical power	P_{BR} [W]	19.5
Current	I_{on} [A]	0.81
Release delay time	t_{BRH} [ms]	80
Application delay time	t_{BRL} [ms]	15
Moment of inertia	J_{BR} [$kgcm^2$]	0.173
Weight of the brake	G_{BR} [kg]	1.1
Typical backlash	[° mech.]	0.31

10.6B AM305x(AM3053 and AM3054)

Technical data		Symbol [Unit]	AM30xx									
			53G	53H	53K	53M	53P	54G	54H	54K	54L	54N
Electrical data												
	Standstill torque *	M_0 [Nm]	11.4	11.51	11.6	11.4	11.4	14.3	14.9	14.4	14.1	14.1
	Standstill current	I_{0rms} [A]	4.77	6.6	9.4	13.4	19.1	5.0	5.5	9.7	12.5	17.8
	Max. mechanical speed	N_{max} [min ⁻¹]	6000									
	Max. rated mains voltage	U_N [VAC]	480									
U = 115V	Rated speed	N_n [min⁻¹]	-	-	-	-	-	-	-	-	-	-
	Rated torque *	M_n [Nm]	-	-	-	-	-	-	-	-	-	-
	Rated output	P_n [kW]	-	-	-	-	-	-	-	-	-	-
U_n = 230V	Rated speed	N_n [min⁻¹]	1000	-	2000	3000	5000	-	1000	1800	2500	3500
	Rated torque *	M_n [Nm]	10.7	-	10.1	8.72	5.88	-	13.35	12.7	11.5	9.85
	Rated output	P_n [kW]	1.12	-	2.12	2.74	3.08	-	1.4	2.39	3.00	3.61
U_n = 400V	Rated speed	N_n [min⁻¹]	2000	3000	4000	-	-	1500	1800	3500	4500	-
	Rated torque *	M_n [Nm]	9.85	8.83	7.65	-	-	12.9	12.6	10.0	8.13	-
	Rated output	P_n [kW]	2.06	2.77	3.20	-	-	2.03	2.38	3.68	3.83	-
U_n = 480V	Rated speed	N_n [min⁻¹]	2400	3500	4500	-	-	2000	2000	4000	-	-
	Rated torque *	M_n [Nm]	9.50	8.23	6.85	-	-	12.3	12.22	9.25	-	-
	Rated output	P_n [kW]	2.39	3.02	3.23	-	-	2.57	2.56	3.87	-	-
	Peak current	I_{0max} [A]	23.9	33.0	47.0	67.0	95.5	25.0	27.5	48.5	62.5	89.0
	Peak torque	M_{0max} [Nm]	42.2	42.4	42.6	42.1	42.1	54.4	53.9	54.8	53.9	54.0
	Torque constant	K_{Tms} [Nm/A]	2.39	1.75	1.24	0.85	0.60	2.88	2.57	1.50	1.13	0.80
	Voltage constant	K_{Erms} [mV/min]	154	112.4	79.8	54.7	38.4	185	165.6	96.6	72.9	51.3
	Winding resistance Ph-PH	R_{25} [Ω]	3.97	2.1	1.06	0.51	0.28	4.08	3.2	1.08	0.65	0.33
	Winding inductance Ph-PH	L [mH]	21.3	11.4	5.70	2.70	1.30	22.9	18.3	6.20	3.50	1.80

* reference flange aluminium 305mm x 305mm x 12.7mm

Options such as sealing ring, holding brake, EnDAT or BiSS lead to a reduction of the rated data.

Mechanical data		AM3053		AM3054	
Rotor moment of inertia	J [kgcm ²]	9.1		12	
Pole number		10		10	
Static friction torque	M_R [Nm]	0.058		0.077	
Thermal time constant	t_{TH} [min]	28		31	
Weight, standard	G [kg]	7.4		9	
Permitted radial force at shaft end	F_R [N]	450			
Permitted axial force	F_A [N]	180			

Data for optional brake

Data	Symbol [Unit]	Value
Holding torque at 120 °C	M_{BR} [Nm]	14.5
Supply voltage	U_{BR} [VDC]	24 ± 10 %
Electrical power	P_{BR} [W]	19.5
Current	I_{on} [A]	0.81
Release delay time	t_{BRH} [ms]	80
Application delay time	t_{BRL} [ms]	15
Moment of inertia	J_{BR} [kgcm ²]	0.173
Weight of the brake	G_{BR} [kg]	1.1
Typical backlash	[° mech.]	0.31

10.6.1 Dimensional drawing

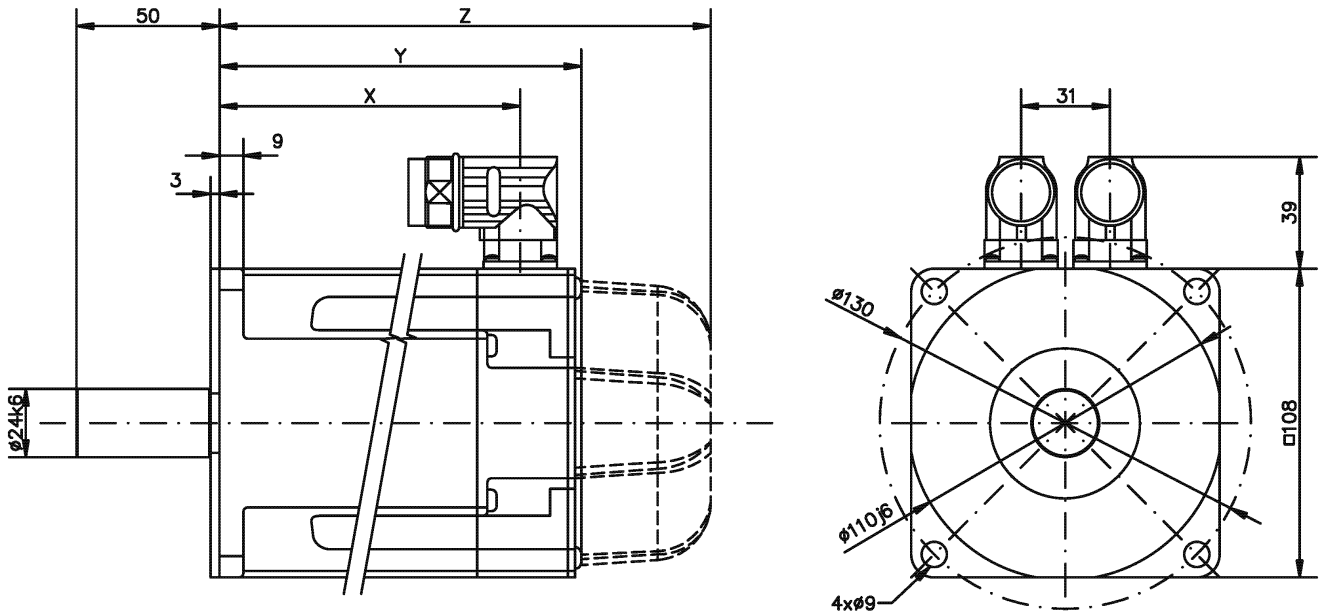

Motor type	X	Resolver		Encoder	
		Y	Z (brake)		
AM3051	105,3	127,5	172,5	146,0	189,0
AM3052	136,3	158,5	203,5	177,0	220,0
AM3053	167,3	189,5	234,5	208,0	251,0
AM3054	198,3	220,5	265,5	239,0	282,0

Optional: Feather key

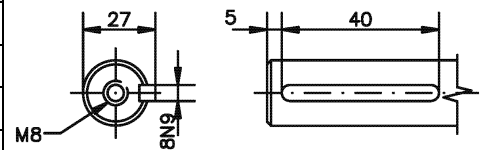

10.6.2 Radial / axial forces at the shaft end

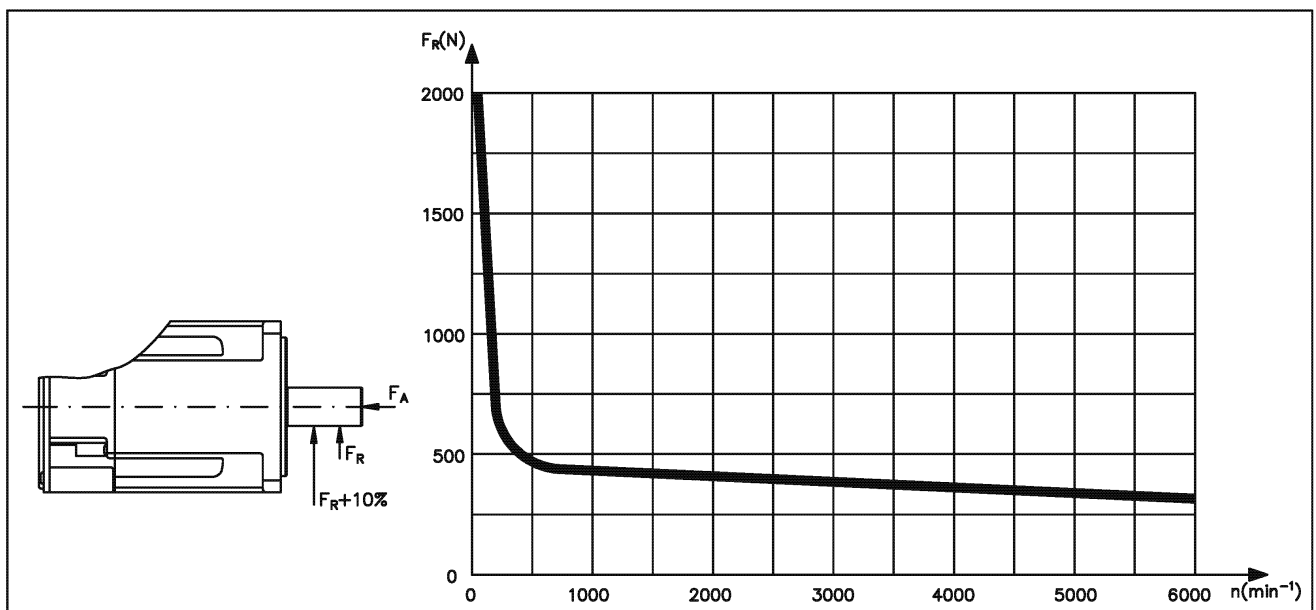

10.6.3 Characteristic torque / speed curves

Characteristic torque / speed curves can be found on the Beckhoff-website under [Drive Technology](#).

10.7 AM306x

Technical data		Symbol [Unit]	AM30xx															
			62G	62H	62K	62M	62P	63H	63K	63M	63N	64K	64L	64P	65K	65M	65N	65P
Electrical data																		
	Standstill torque *	M_0 [Nm]	11.9	11.9	12.2	12.2	12.3	16.6	16.8	17.0	17.0	20.8	21.0	20.4	24.8	25.0	24.3	24,5
	Standstill current	I_{orms} [A]	4.9	5.4	9.6	13.4	18.8	5.6	9.9	13.8	17.4	9.2	12.8	18.6	9.8	13.6	17.8	19,8
	Max. mechanical speed	N_{max} [min ⁻¹]	6000															
	Max. rated mains voltage	U_N [VAC]	480															
$U = 115V$	Rated speed	N_n [min ⁻¹]	-	-	-	-	-	-	-	-	-	-	-	-	-	-	-	-
	Rated torque *	M_n [Nm]	-	-	-	-	-	-	-	-	-	-	-	-	-	-	-	-
	Rated output	P_n [kW]	-	-	-	-	-	-	-	-	-	-	-	-	-	-	-	-
$U_N = 230V$	Rated speed	N_n [min ⁻¹]	-	1000	2000	3000	4500	-	1500	2000	3000	1200	1500	2500	1000	1500	2000	2400
	Rated torque *	M_n [Nm]	-	11.2	10.4	9.50	8.10	-	14.9	14.3	13.0	18.8	18.4	16.0	22.8	21.9	19.8	19,1
	Rated output	P_n [kW]	-	1.17	2.18	2.98	3.82	-	2.34	2.99	4.08	2.36	2.89	4.19	2.39	3.44	4.15	4,8
$U_N = 400V$	Rated speed	N_n [min ⁻¹]	1800	2000	3500	6000	-	1500	3000	4000	5000	2000	3000	4500	2000	2500	3500	4000
	Rated torque *	M_n [Nm]	10.4	10.2	9.00	5.70	-	15.3	12.9	11.3	9.60	17.2	15.6	11.9	20.2	19.2	16.0	14,9
	Rated output	P_n [kW]	1.96	2.14	3.30	3.58	-	2.34	4.05	4.73	5.03	3.60	4.90	5.61	4.23	5.03	5.86	6,24
$U_N = 480V$	Rated speed	N_n [min ⁻¹]	2000	2400	4500	6000	-	1800	3500	4500	6000	2500	3500	5500	2200	3000	4000	5000
	Rated torque *	M_n [Nm]	10.2	9.9	8.0	5.70	-	14.2	12.0	10.5	7.00	16.3	14.4	9.00	19.7	18.1	14.7	11,6
	Rated output	P_n [kW]	2.14	2.49	3.77	3.58	-	2.68	4.40	4.95	4.40	4.27	5.28	5.18	4.54	5.69	6.16	6,08
	Peak current	I_{0max} [A]	24.5	27.1	48.0	67.0	94.5	28.0	49.5	69.0	87.0	46.0	64.0	93.0	49.0	68.0	89.0	98,9
	Peak torque	M_{0max} [Nm]	40.9	40.8	41.2	41.2	41.4	58.9	59.4	59.8	59.8	76.1	76.6	75.2	92.4	93.0	91.6	92,0
	Torque constant	K_{Trms} [Nm/A]	2.47	2.2	1.28	0.91	0.66	3.0	1.71	1.24	0.98	2.28	1.66	1.10	2.54	1.85	1.38	1,3
	Voltage constant	$K_{E rms}$ [mV/min]	159	142.1	82.1	58.8	42.2	191.5	110	79.9	63.3	147	107	71.0	164	119	88.8	80,5
	Winding resistance Ph-PH	R_{25} [Ω]	4.13	3.3	1.08	0.57	0.30	3.43	1.14	0.61	0.39	1.41	0.75	0.36	1.35	0.73	0.43	0,37
	Winding inductance Ph-PH	L [mH]	37.7	25.4	8.5	4.4	2.2	28.1	9.3	4.9	3.1	11.8	6.2	2.8	11.4	6.1	3.4	2,8

* reference flange aluminium 457mm x 457mm x 12.7mm

Options such as sealing ring, holding brake, EnDAT or BiSS lead to a reduction of the rated data.

Mechanical data		AM3062	AM3063	AM3064	AM3065
Rotor moment of inertia	J [kgcm ²]	17	24	32	40
Pole number		10	10	10	10
Static friction torque	M_R [Nm]	0.05	0.1	0.15	0.2
Thermal time constant	t_{TH} [min]	20	25	30	35
Weight, standard	G [kg]	8.9	11.1	13.3	15.4
Permitted radial force at shaft end	F_R [N]	770			
Permitted axial force	F_A [N]	280			

Data for optional brake

Data	Symbol [Unit]	Value
Holding torque at 120 °C	M_{BR} [Nm]	25
Supply voltage	U_{BR} [VDC]	24 ± 10 %
Electrical power	P_{BR} [W]	25.7
Current	I_{on} [A]	1.07
Release delay time	t_{BRH} [ms]	105
Application delay time	t_{BRL} [ms]	20
Moment of inertia	J_{BR} [kgcm ²]	0.61
Weight of the brake	G_{BR} [kg]	2
Typical backlash	[°mech.]	0.24

10.7.1 Dimensional drawing

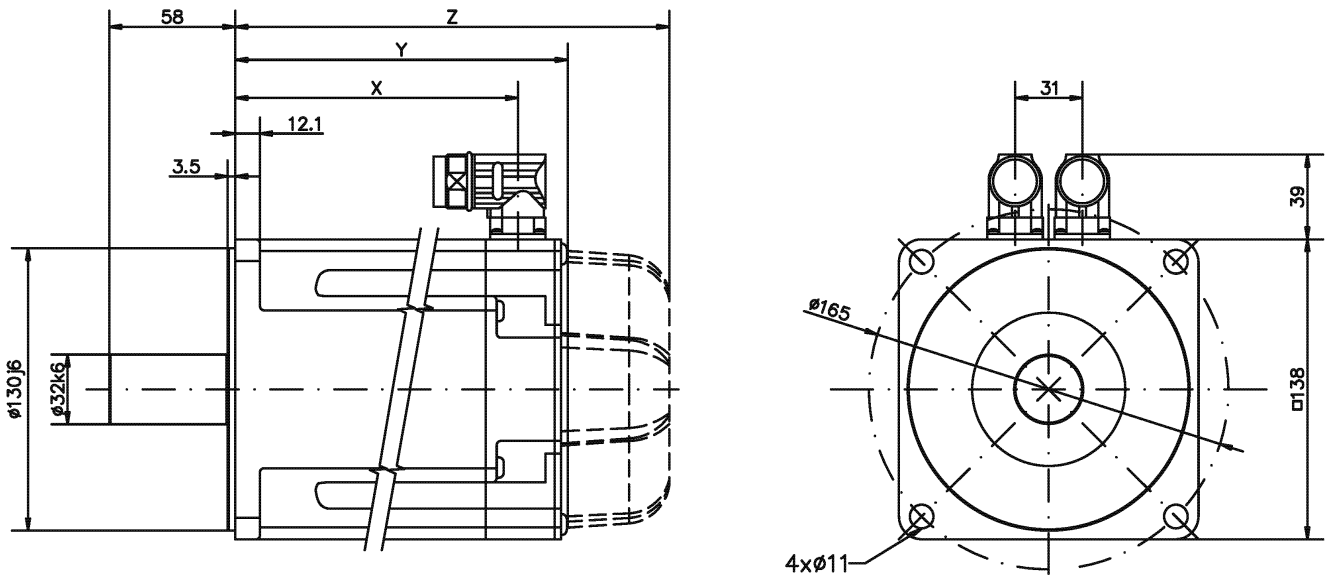

Motor type	X	Resolver		Encoder	
		Y	Z (brake)		
AM3062	130,5	153,7	200,7	172,2	219,7
AM3063	155,5	178,7	225,7	197,2	244,7
AM3064	180,5	203,7	250,7	222,2	269,7
AM3065	205,5	228,7	275,7	247,2	294,7

Optional: Feather key

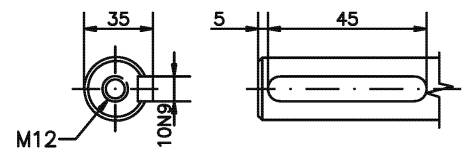

10.7.2 Radial / axial forces at the shaft end

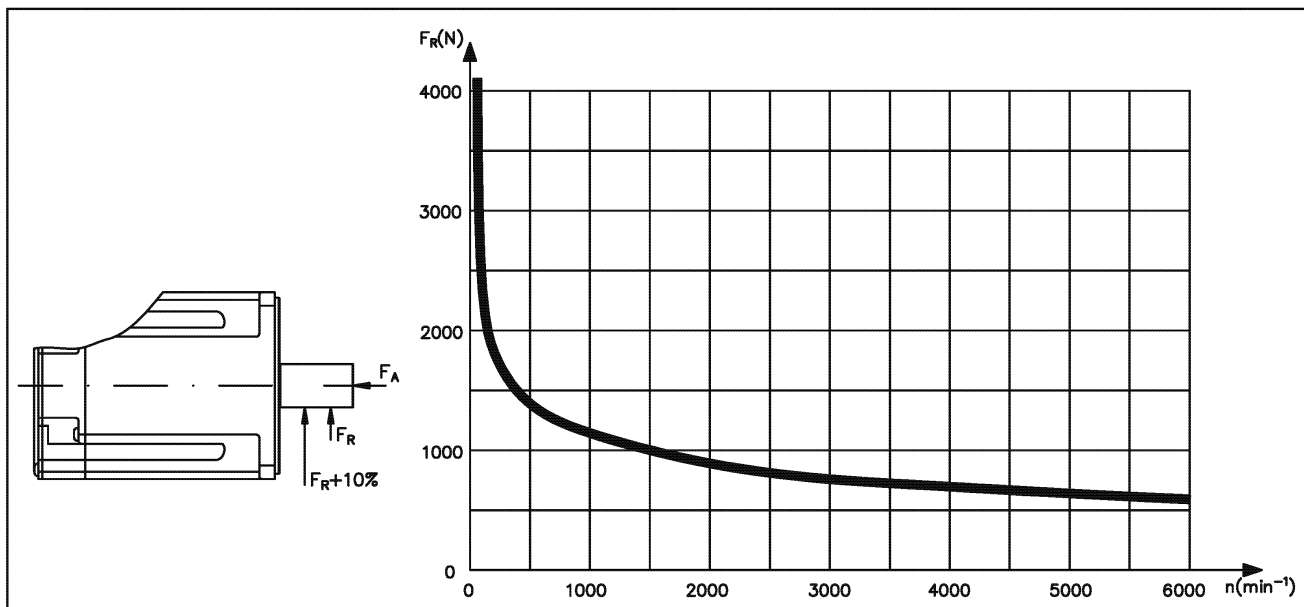

10.7.3 Characteristic torque / speed curves

Characteristic torque / speed curves can be found on the Beckhoff-website under [Drive Technology](#).

10.8 AM307x

Technical data		Symbol [Unit]	AM30xx									
			72K	72M	72P	72Q	73M	73P	73Q	74L	74P	74Q
Electrical data												
	Standstill torque *	M_0 [Nm]	29.7	30.0	29.4	29.7	42.0	41.6	41.6	53.0	52.5	51.9
	Standstill current	I_{orms} [A]	9.3	13.0	18.7	20.9	13.6	19.5	24.6	12.9	18.5	26.2
	Max. mechanical speed	N_{max} [min ⁻¹]	6000									
	Max. rated mains voltage	U_N [VAC]	480									
U = 115V	Rated speed	N_n [min ⁻¹]	-	-	-	-	-	-	-	-	-	-
	Rated torque *	M_n [Nm]	-	-	-	-	-	-	-	-	-	-
	Rated output	P_n [kW]	-	-	-	-	-	-	-	-	-	-
U _N = 230V	Rated speed	N_n [min ⁻¹]	-	-	1800	-	-	1300	-	-	-	-
	Rated torque *	M_n [Nm]	-	-	23.8	-	-	34.7	-	-	-	-
	Rated output	P_n [kW]	-	-	4.49	-	-	4.72	-	-	-	-
U _N = 400V	Rated speed	N_n [min ⁻¹]	1500	2000	3000	3500	1500	2400	3000	1200	1800	2500
	Rated torque *	M_n [Nm]	25.1	23.6	20.1	18.41	33.8	28.5	25.2	43.5	39.6	31.4
	Rated output	P_n [kW]	3.94	4.94	6.31	6.75	5.31	7.16	7.92	5.47	7.46	8.22
U _N = 480V	Rated speed	N_n [min ⁻¹]	1800	2500	3500	4000	1800	2800	3500	1400	2000	3000
	Rated torque *	M_n [Nm]	24.0	22.1	18.2	16.4	32.1	26.3	22	41.5	35.9	27.1
	Rated output	P_n [kW]	4.52	5.79	6.67	6.87	6.05	7.71	8.06	6.08	7.52	8.51
	Peak current	I_{0max} [A]	46.5	65.0	93.5	117.5	68.0	97.5	122.6	64.5	92.5	130.5
	Peak torque	M_{0max} [Nm]	118.8	119.3	117.6	117.5	169.8	168.0	168.0	217.6	215.3	214.3
	Torque constant	K_{Trms} [Nm/A]	3.23	2.33	1.58	1.42	3.10	2.13	1.69	4.14	2.84	1.98
	Voltage constant	K_{Ems} [mV/min]	208	150	102	91.6	200	137	109.2	266	183	129
	Winding resistance Ph-PH	R_{25} [Ω]	1.36	0.69	0.35	0.321	0.76	0.38	0.24	0.93	0.47	0.264
	Winding inductance Ph-PH	L [mH]	20.7	10.8	5.0	4.0	12.4	5.9	3.7	16.4	7.7	3.8

* reference flange aluminium 457mm x 457mm x 12.7mm

Options such as sealing ring, holding brake, EnDAT or BiSS lead to a reduction of the rated data.

Mechanical data		AM3072	AM3073	AM3074
Rotor moment of inertia	J [kgcm ²]	65	92	120
Pole number		10	10	10
Static friction torque	M_R [Nm]	0.16	0.24	0.33
Thermal time constant	t_{TH} [min]	46	53	60
Weight, standard	G [kg]	19.7	26.7	33.6
Permitted radial force at shaft end	F_R [N]	1300		
Permitted axial force	F_A [N]	500		

Data for optional brake

Data	Symbol [Unit]	Value
Holding torque at 120 °C	M_{BR} [Nm]	53
Supply voltage	U_{BR} [VDC]	24 ± 10 %
Electrical power	P_{BR} [W]	35.6
Current	I_{on} [A]	1.48
Release delay time	t_{BRH} [ms]	110
Application delay time	t_{BRL} [ms]	35
Moment of inertia	J_{BR} [kgcm ²]	1.64
Weight of the brake	G_{BR} [kg]	2.1
Typical backlash	[°mech.]	0.2

10.8.1 Dimensional drawing

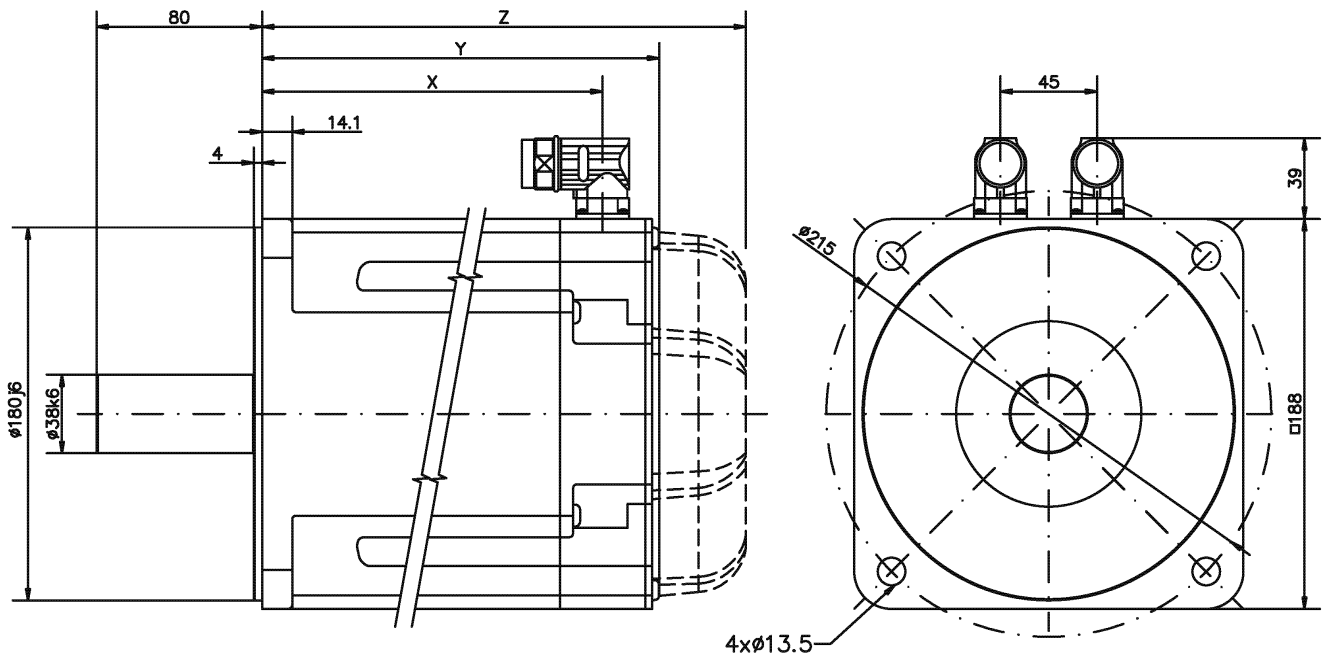

Motor type	X	Resolver		Encoder	
		Y	Z (brake)		
AM3072	164,5	192,5	234,5	201,7	253,3
AM3073	198,5	226,5	268,5	235,7	287,3
AM3074	232,5	260,5	302,5	269,7	321,3

Optional: Feather key

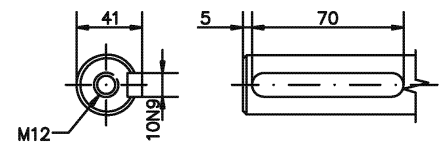

10.8.2 Radial / axial forces at the shaft end

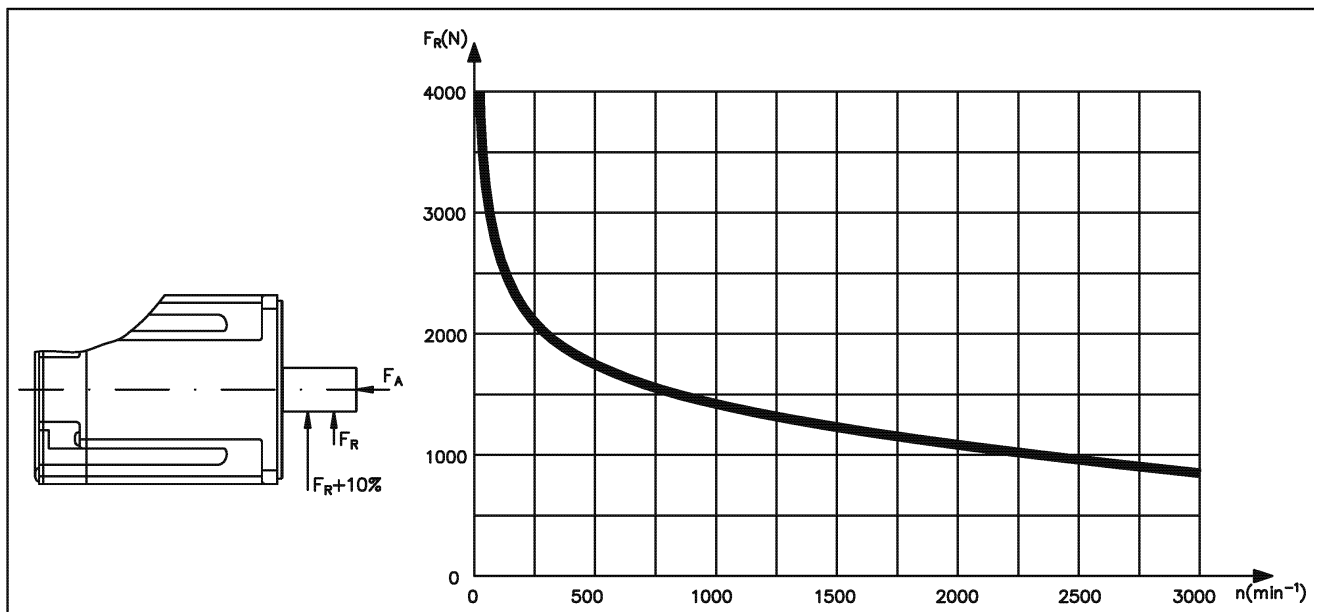

10.8.3 Characteristic torque / speed curves

Characteristic torque / speed curves can be found on the Beckhoff-website under [Drive Technology](#).

10.9 AM308x

Technical data		Symbol [Unit]	AM30xx			
			82T	83T	84T	
	Standstill torque *	M_0 [Nm]	75	130	180	
	Standstill current	I_{oms} [A]	48	62	67	
	Max. mechanical speed	N_{max} [min^{-1}]	4500			
	Max. rated mains voltage	U_N [VAC]	480			
U = 115V	Rated speed	N_n [min^{-1}]	-	-	-	
	Rated torque*	M_n [Nm]	-	-	-	
	Rated output	P_n [kW]	-	-	-	
U _N = 230V	Rated speed	N_n [min^{-1}]	-	-	-	
	Rated torque *	M_n [Nm]	-	-	-	
	Rated output	P_n [kW]	-	-	-	
U _N = 400V	Rated speed	N_n [min^{-1}]	2500	2200	1800	
	Rated torque *	M_n [Nm]	47.5	70	105	
	Rated output	P_n [kW]	12.4	16.1	19.8	
U _N = 480V	Rated speed	N_n [min^{-1}]	3000	2500	2000	
	Rated torque *	M_n [Nm]	38	60	93	
	Rated output	P_n [kW]	11.9	15.7	19.5	
	Peak current	I_{0max} [A]	240	310	335	
	Peak torque	M_{0max} [Nm]	210	456	668	
	Torque constant	K_{Trms} [Nm/A]	1.6	2.1	2.7	
	Voltage constant	$K_{E rms}$ [mV/min]	108	140	177	
	Winding resistance Ph-PH	R_{25} [Ω]	0.092	0.061	0.058	
	Winding inductance Ph-PH	L [mH]	2.73	2.36	2.5	

* reference flange aluminium mm x mm x mm

Options such as sealing ring, holding brake, EnDAT or BiSS lead to a reduction of the rated data.

Mechanical data		AM3082	AM3083	AM3084
Rotor moment of inertia	J [$kgcm^2$]	172	334	495
Pole number		10	10	10
Static friction torque	M_R [Nm]	1.7	1.83	2.34
Thermal time constant	t_{TH} [min]	71	94	116
Weight, standard	G [kg]	65	85	105
Permitted radial force at shaft end	F_R [N]	see chapter 10.9.2		
Permitted axial force	F_A [N]	see chapter 10.9.2		

Data for optional brake

Data	Symbol [Unit]	Value
Holding torque at 120 °C	M_{BR} [Nm]	150
Supply voltage	U_{BR} [VDC]	24 ± 10%
Electrical power	P_{BR} [W]	49
Moment of inertia	J_{BR} [$kgcm^2$]	5.53
Release delay time	t_{BRH} [ms]	300
Application delay time	t_{BRL} [ms]	500
Weight of the brake	G_{BR} [kg]	8
Typical backlash	[°mech.]	0.2

10.9.1 Dimensional drawing

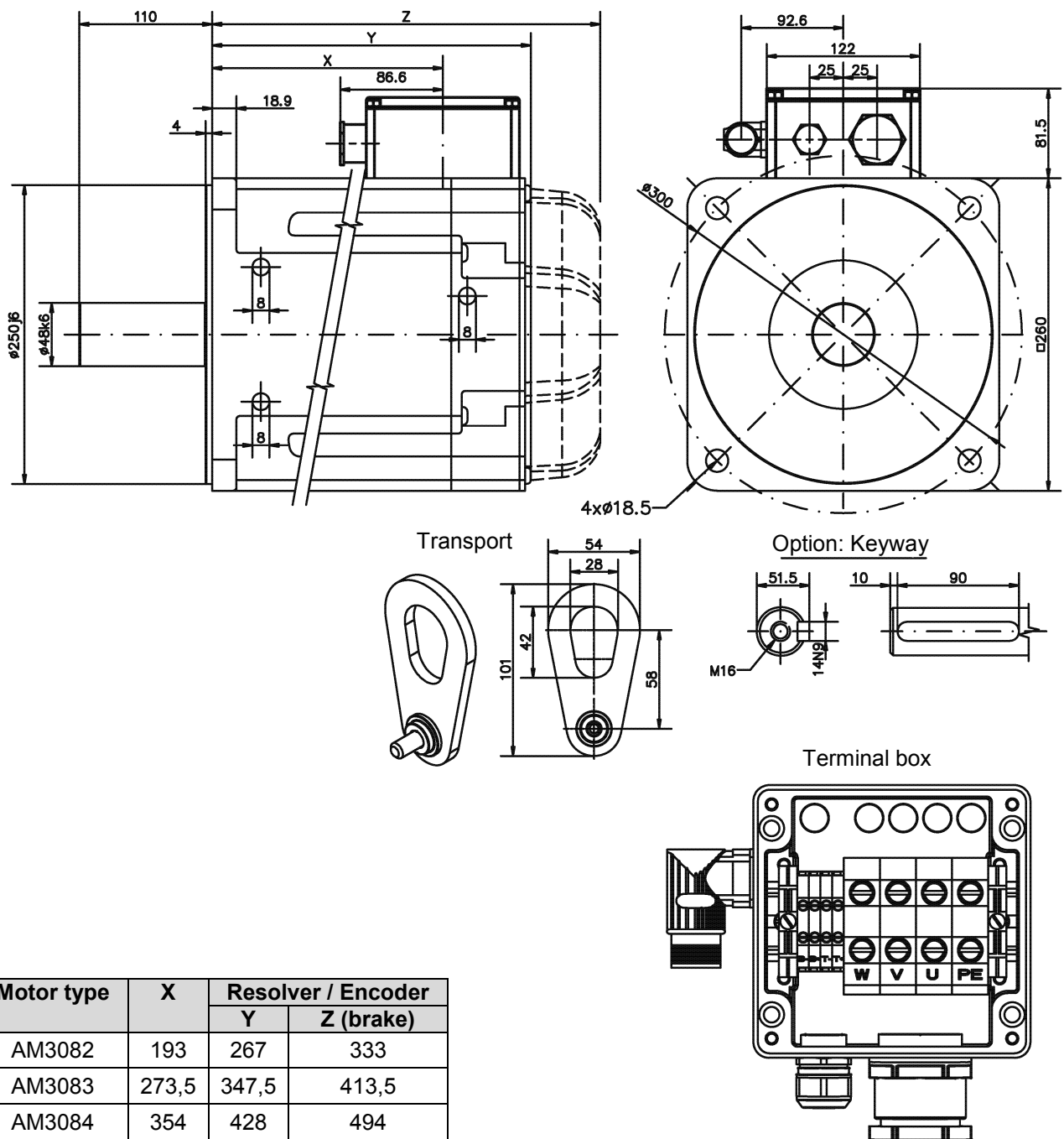

10.9.2 Radial / axial forces at the shaft end

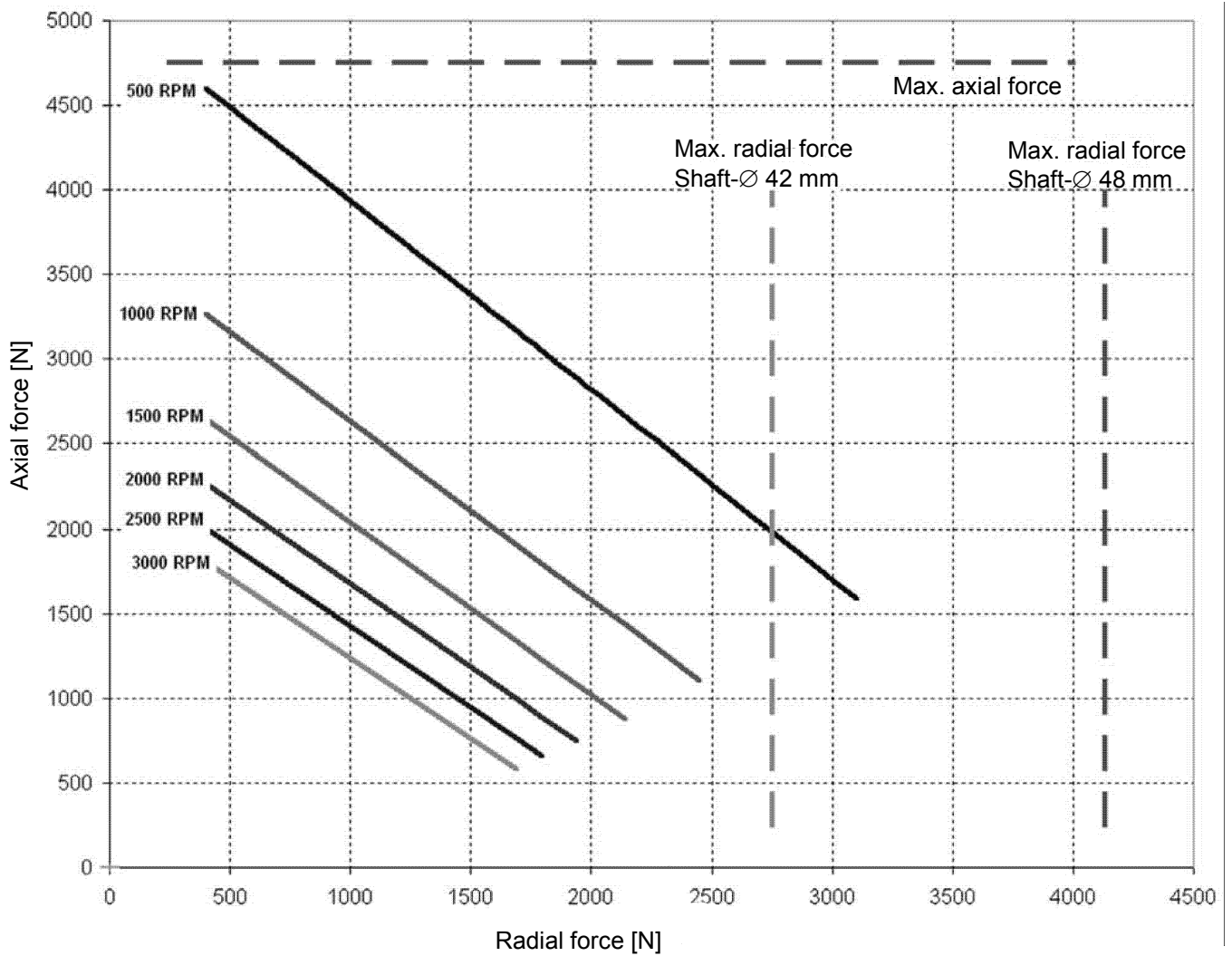

10.9.3 Characteristic torque / speed curves

Characteristic torque / speed curves can be found on the Beckhoff-website under [Drive Technology](#).

10.10 AM354x

Technical data	Symbol [Unit]	AM3541		AM3542		AM3543	
		3000	6000	3000	6000	3000	6000
Electrical data							
Standstill torque *	M_0 [Nm]	1.9		3.3		4.2	
Standstill current	I_{0rms} [A]	1.7	2.8	2.4	4.5	3	5.2
Max. rated mains voltage	U_N [VAC]	480					
Rated speed **	N_n [min ⁻¹]	3000	6000	3000	6000	3000	6000
Rated torque	M_n [Nm]	1.6	1.2	2.9	2.1	3.0	1.9
Rated current	I_n [A]	1.46	1.92	2.3	3.1	2.3	2.7
Peak current	I_{0max} [A]	6.7	11.2	10.6	19.5	12.9	23
Peak torque	M_{0max} [Nm]	5.2	5.2	9.5	9.5	12.3	12.3
Torque constant	K_{Trms} [Nm/A]	1.14	0.68	1.34	0.73	1.42	0.8
Voltage constant	$K_{E rms}$ [mV/min]	69	41	81	44	86	48.5
Winding resistance Ph-PH	R_{25} [Ω]	11.6	3.9	6.5	2	4.6	1.48
Winding inductance Ph-PH	L [mH]	42.3	14.9	30.6	9.1	26.1	8.4

*) reference flange aluminium 210 mm x 210 mm x 10 mm

Options such as sealing ring, holding brake, EnDAT or BiSS lead to a reduction of the rated data.

**) at 400 V supply voltage

Mechanical data		3541		3542		3543	
Rotor moment of inertia	J [kgcm ²]	2		4		8	
Pole number		10					
Thermal time constant	t_{TH} [min]	30	30	33	33	36	36
Weight, standard	G [kg]	2.38	2.38	3.8	3.8	5.35	5.35
Permitted radial load at shaft end	F_R [N]	368	-	406	-	427	-
Permitted axial load at shaft end	F_A [N]	70	-	77	-	81	-

Data for optional brake

Data	Symbol [Unit]	Value
Holding torque at 100 °C	M_{BR} [Nm]	4.5
Supply Voltage	U_{BR} [VDC]	24
Electrical power	P_{BR} [W]	12
Current	I_{on} [A]	0.5
Release delay time	t_{BRH} [ms]	35
Application delay time	t_{BRL} [ms]	7
Moment of inertia	J_{BR} [kgcm ²]	0.2
Weight of the brake	G_{BR} [kg]	0.6
Typical backlash	°mech	0

Tolerances for all data ±10%

10.10.1 Dimensional drawing

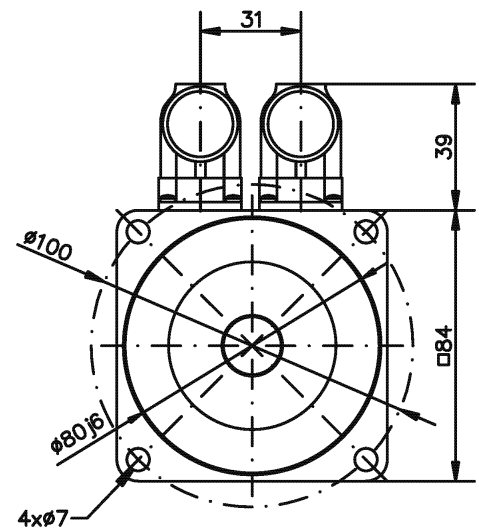
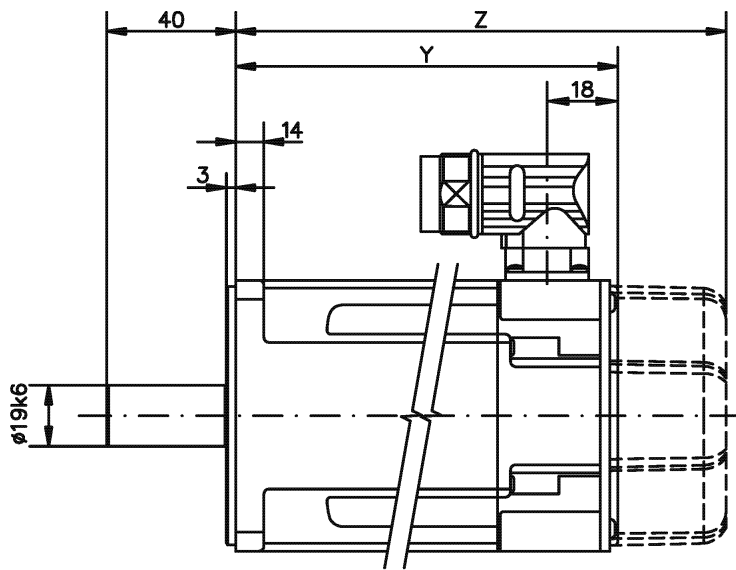

Motor type	Resolver		BiSS	
	Y	Z (brake)		Y
AM3541	159	181	189	211
AM3542	195	233	225	263
AM3543	231	309	261	339

Optional: Feather key

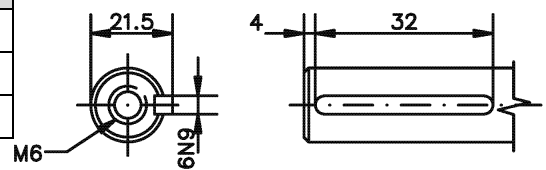

10.10.2 Characteristic torque / speed curves

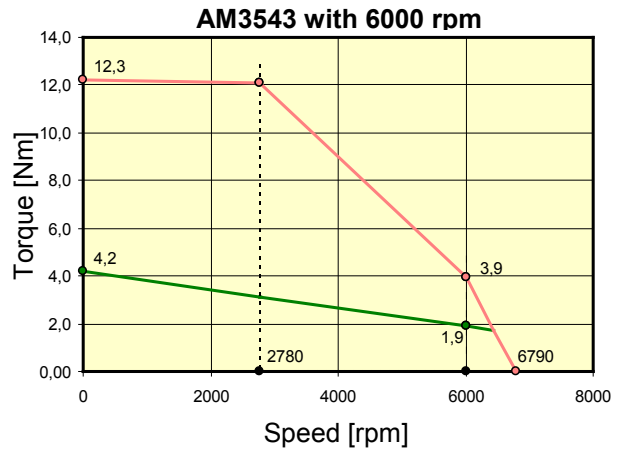
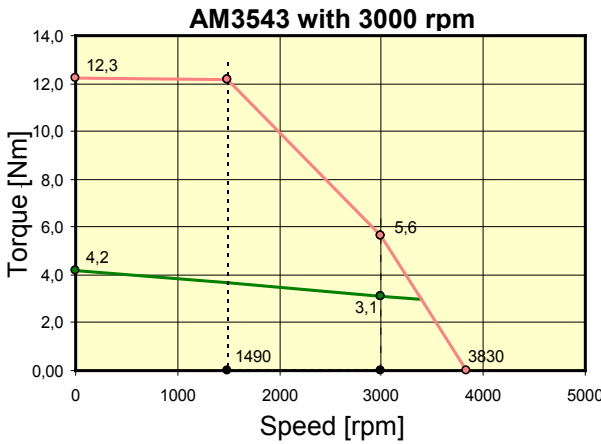
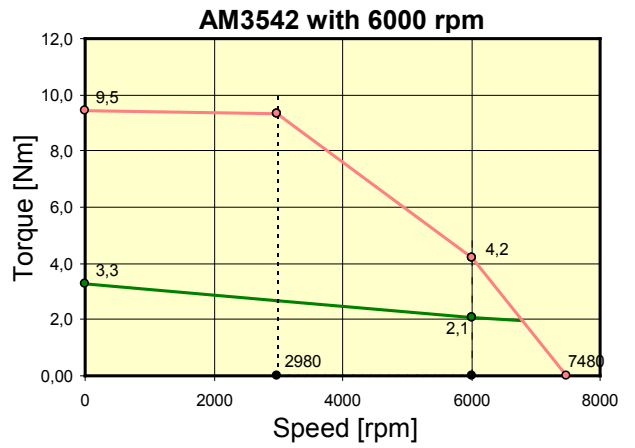
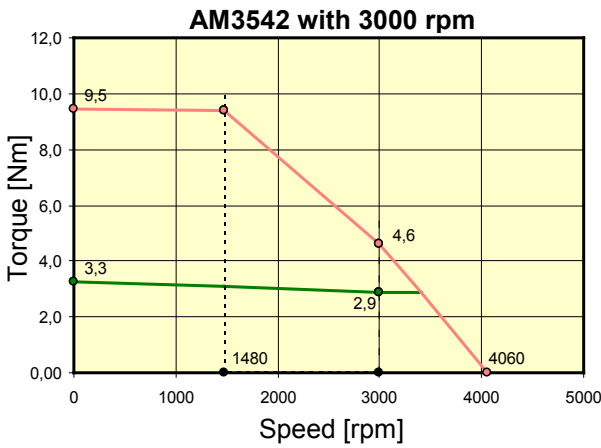
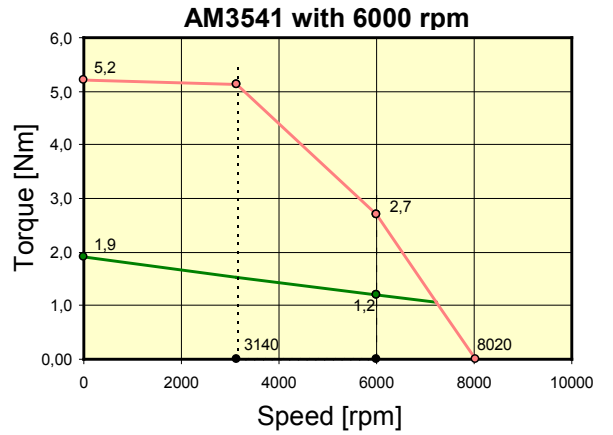
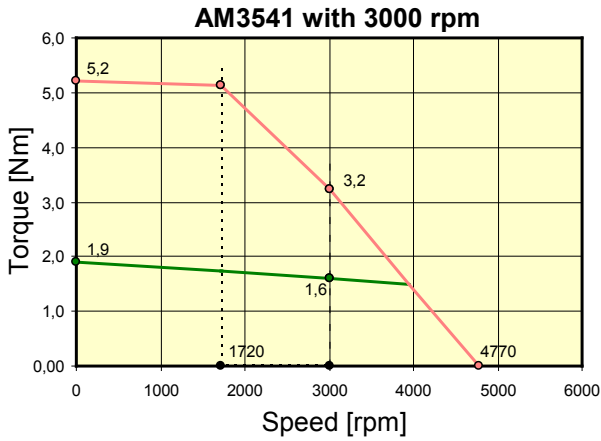

10.11 AM355x

Data	Symbol [Unit]	AM3551		AM3552	AM3553
		3000	6000	3000	3000
Electrical data					
Standstill torque *	M_0 [Nm]	4.1		6.3	8.6
Standstill current	I_{orms} [A]	3.4	6.1	4.8	6.4
Max. rated mains voltage	U_N [VAC]	480			
Rated speed **	N_n [min ⁻¹]	3000	6000	3000	3000
Rated torque	M_n [Nm]	3.2	1.7	4.6	6.1
Rated current	I_n [A]	2.8	2.9	3.6	4.8
Peak current	I_{0max} [A]	13.6	24	21	31
Peak torque	M_{0max} [Nm]	11.1	11.1	18.5	27
Torque constant	K_{Trms} [Nm/A]	1.19	0.66	1.32	1.34
Voltage constant	K_{Erms} [mVmin]	72	40	80	81
Winding resistance Ph-PH	R_{25} [Ω]	4	1.23	2.7	1.81
Winding inductance Ph-PH	L [mH]	34	10.4	25.5	18.6

*) reference flange aluminium 270 mm x 270 mm x 10 mm

Options such as sealing ring, holding brake, EnDAT or BiSS lead to a reduction of the rated data.

***) at 400 V supply voltage

Mechanical data		AM3551	AM3552	AM3553
Rotor moment of inertia	J [kgcm ²]	15	19	20
Pole number		10		
Thermal time constant	t_{TH} [min]	29	31	33
Weight, standard	G [kg]	5.8	7.0	8.9
Permitted radial load at shaft end	F_R [N]	594	648	682
Permitted axial load at shaft end	F_A [N]	113	123	130

Data for optional brake

Data	Symbol [Unit]	Value
Holding torque at 100 °C	M_{BR} [Nm]	9
Supply Voltage	U_{BR} [VDC]	24
Electrical power	P_{BR} [W]	18
Current	I_{on} [A]	0.75
Release delay time	t_{BRH} [ms]	40
Application delay time	t_{BRL} [ms]	7
Moment of inertia	J_{BR} [kgcm ²]	0.6
Weight of the brake	G_{BR} [kg]	0.82
Typical backlash	$^{\circ}mech$	0

Tolerances for all data $\pm 10\%$

10.11.1 Dimensional drawing

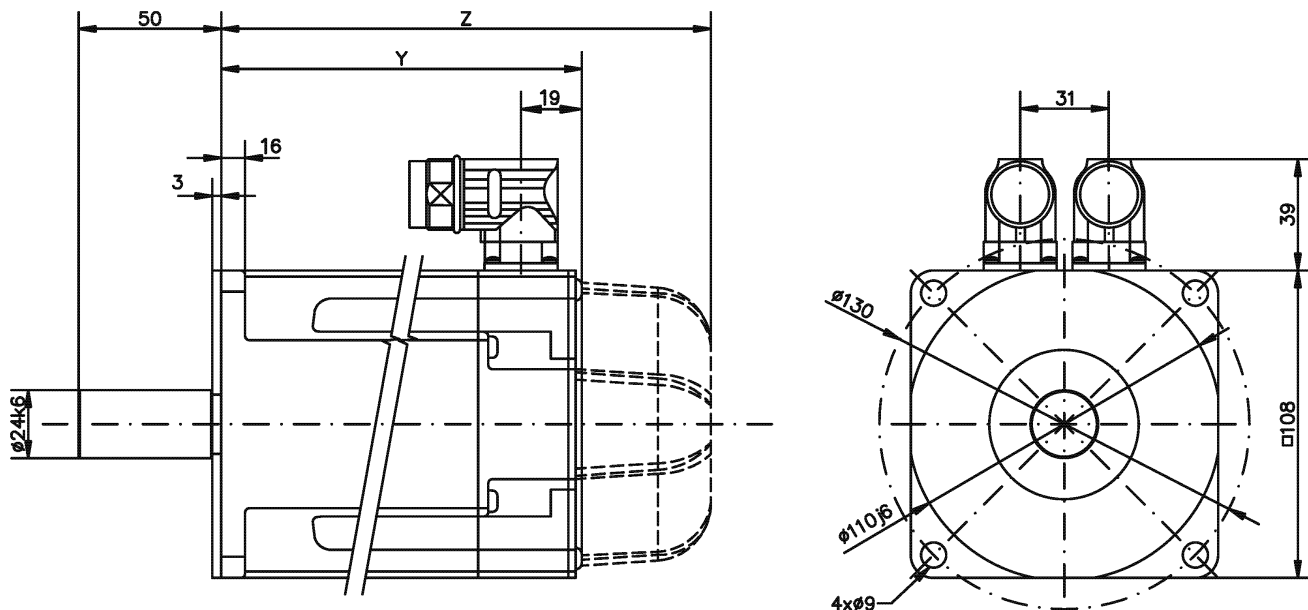

Motor type	Resolver		BiSS	
	Y	Z (brake)		Y
AM3551	172	223	202	253
AM3552	202	262	232	292
AM3553	232	292	262	322

Optional: Feather key

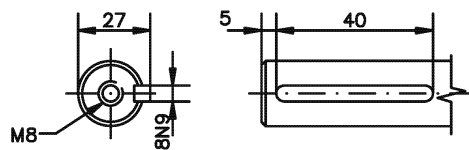

10.11.2 Characteristic torque / speed curves

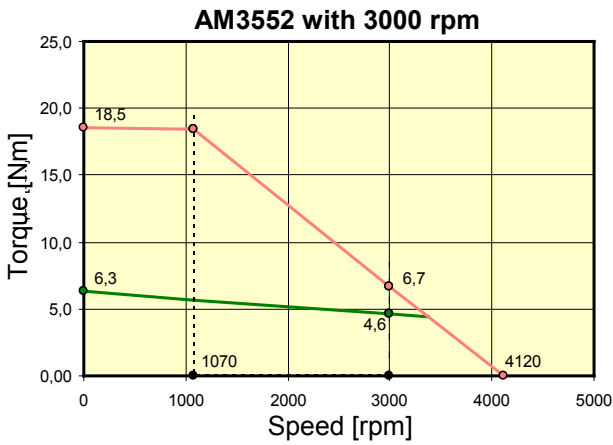
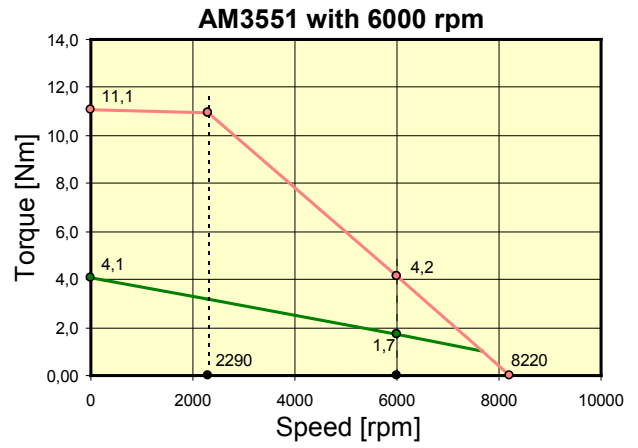
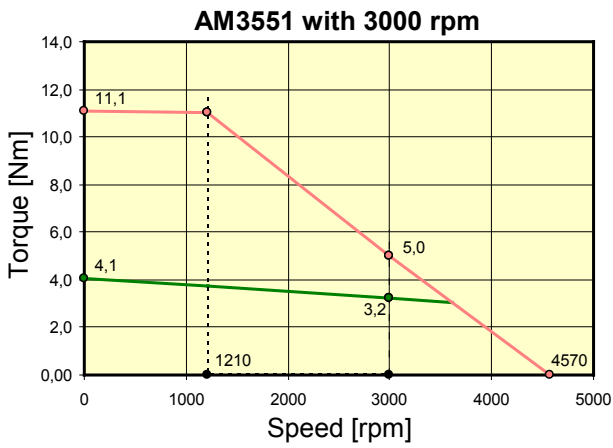

Currently not available

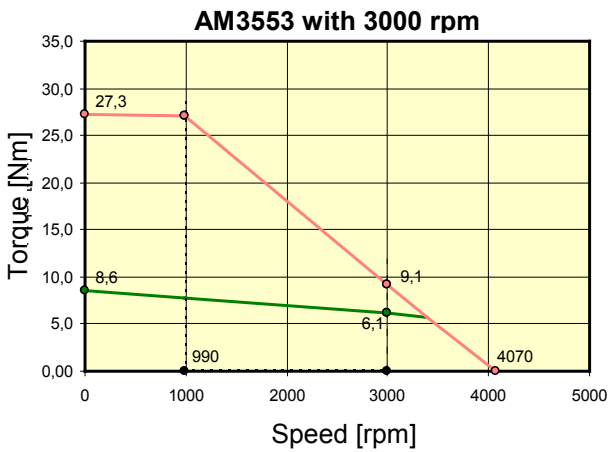

AM3553 with 3000 rpm

Currently not available

10.12 AM356x

Data	Symbol [Unit]	AM3562	AM3563
		3000	3000
Electrical data			
Standstill torque *	M_0 [Nm]	11.6	14.9
Standstill current	I_{0rms} [A]	10.3	12.5
Max. rated mains voltage	U_N [VAC]	480	
Rated speed **	N_n [min ⁻¹]	3000	3000
Rated torque	M_n [Nm]	8.4	10.9
Rated current	I_n [A]	7.9	9.6
Peak current	I_{0max} [A]	49	49
Peak torque	M_{0max} [Nm]	32	41
Torque constant	K_{Trms} [Nm/A]	1.12	1.19
Voltage constant	K_{Erms} [mVmin]	68	72
Winding resistance Ph-PH	R_{25} [Ω]	0.71	0.48
Winding inductance Ph-PH	L [mH]	11.4	8.5

*) reference flange aluminium 345 mm x 345 mm x 10 mm

Options such as sealing ring, holding brake, EnDAT or BiSS lead to a reduction of the rated data.

***) at 400 V supply voltage

Mechanical data		3562	3563
Rotor moment of inertia	J [kgcm ²]	40	60
Pole number		10	
Thermal time constant	t_{TH} [min]	50	55
Weight, standard	G [kg]	10.7	13.6
Permitted radial load at shaft end	F_R [N]	672	713
Permitted axial load at shaft end	F_A [N]	128	135

Data for optional brake

Data	Symbol [Unit]	Value
Holding torque at 100 °C	M_{BR} [Nm]	16
Supply Voltage	U_{BR} [VDC]	24
Electrical power	P_{BR} [W]	24
Current	I_{on} [A]	1
Release delay time	t_{BRH} [ms]	50
Application delay time	t_{BRL} [ms]	10
Moment of inertia	J_{BR} [kgcm ²]	2
Weight of the brake	G_{BR} [kg]	1.1
Typical backlash	$^{\circ}mech$	0

Tolerances for all data $\pm 10\%$

10.12.1 Dimensional drawing

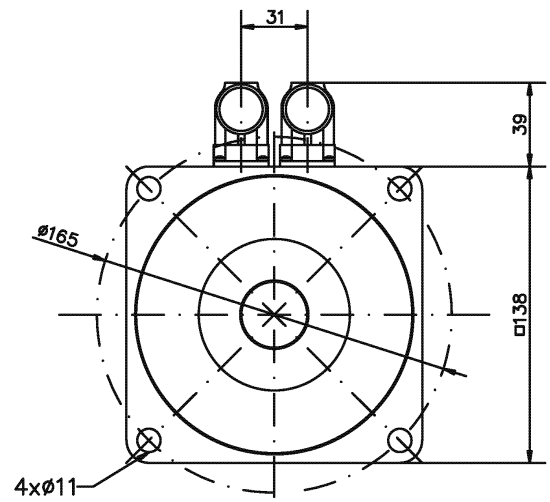
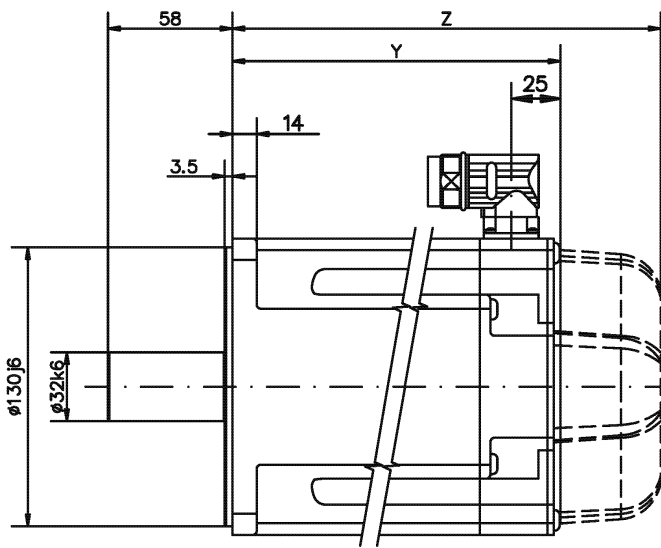

Motor type	Resolver		BiSS	
	Y	Z (brake)	Y	Y
AM3562	223	262	233	289
AM3563	251	304	261	317

Optional: Feather key

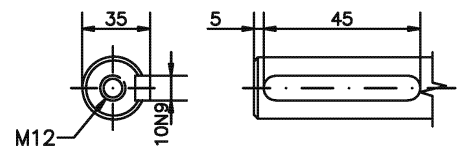

10.12.2 Characteristic torque / speed curves

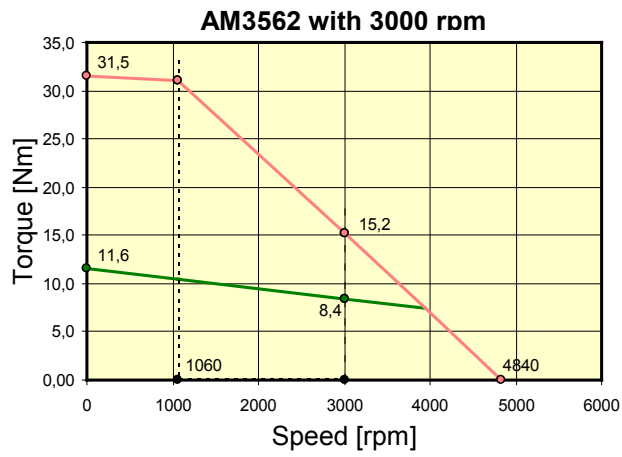

AM3562 with 6000 rpm

Currently not available

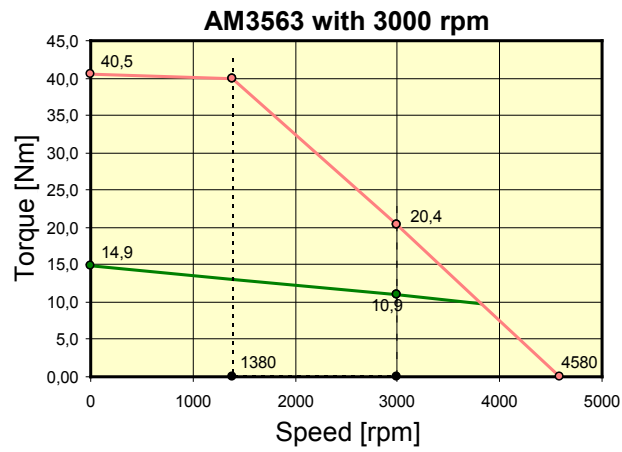

AM3563 with 6000 rpm

Currently not available

11 Appendix

11.1 Support and Service

Beckhoff and their partners around the world offer comprehensive support and service, making available fast and competent assistance with all questions related to Beckhoff products and system solutions.

11.1.1 Beckhoff Support

Beckhoff offers comprehensive technical support that deals not only with the application of individual Beckhoff products, but offers extensive additional services:

- support
- design, programming and commissioning of complex automation systems
- extensive training program for Beckhoff system components

Hotline : +49(0)5246/963-157

Fax : +49(0)5246/963-9157

e-mail : support@beckhoff.com

11.1.2 Beckhoff Service

The Beckhoff Service Center supports you in all matters of after-sales service:

- local service
- repair service
- spare parts service

Hotline : +49(0)5246/963-460

Fax : +49(0)5246/963-479

e-mail: : service@beckhoff.com

11.2 Beckhoff headquarters

Beckhoff Automation GmbH & Co. KG
Hülshorstweg 20
33415 Verl
Germany

Phone: +49(0)5246/963-0

Fax: +49(0)5246/963-198

e-mail: info@beckhoff.com

The addresses of the worldwide Beckhoff branch offices and representatives can be found on our website at www.beckhoff.com You will also find further [documentation](#) for Beckhoff components there.