

# SIEMENS

## SIMATIC

### Distributed I/O ET 200eco PN

#### Operating Instructions

Preface	
Product overview	1
Installing	2
Wiring	3
Configuring	4
Commissioning	5
Maintenance	6
Interrupt, error, and system messages	7
General technical data	8
I/O device digital inputs/digital outputs	9
I/O device analog input/analog output	10
IO-Link Master	11
Terminal block and voltage distributor	12
Signal names	A
Article numbers	B
Dimensional drawings	C
Connection examples	D
I/O address space	E
Response times for analog input device and output device	F
Fail-safe shutdown of ET 200eco PN standard modules	G
Open Source Software	H

## Legal information

### Warning notice system

This manual contains notices you have to observe in order to ensure your personal safety, as well as to prevent damage to property. The notices referring to your personal safety are highlighted in the manual by a safety alert symbol, notices referring only to property damage have no safety alert symbol. These notices shown below are graded according to the degree of danger.

#### **DANGER**

indicates that death or severe personal injury **will** result if proper precautions are not taken.

#### **WARNING**

indicates that death or severe personal injury **may** result if proper precautions are not taken.

#### **CAUTION**

indicates that minor personal injury can result if proper precautions are not taken.

#### **NOTICE**

indicates that property damage can result if proper precautions are not taken.

If more than one degree of danger is present, the warning notice representing the highest degree of danger will be used. A notice warning of injury to persons with a safety alert symbol may also include a warning relating to property damage.

### Qualified Personnel

The product/system described in this documentation may be operated only by **personnel qualified** for the specific task in accordance with the relevant documentation, in particular its warning notices and safety instructions. Qualified personnel are those who, based on their training and experience, are capable of identifying risks and avoiding potential hazards when working with these products/systems.

### Proper use of Siemens products

Note the following:

#### **WARNING**

Siemens products may only be used for the applications described in the catalog and in the relevant technical documentation. If products and components from other manufacturers are used, these must be recommended or approved by Siemens. Proper transport, storage, installation, assembly, commissioning, operation and maintenance are required to ensure that the products operate safely and without any problems. The permissible ambient conditions must be complied with. The information in the relevant documentation must be observed.

### Trademarks

All names identified by ® are registered trademarks of Siemens AG. The remaining trademarks in this publication may be trademarks whose use by third parties for their own purposes could violate the rights of the owner.

### Disclaimer of Liability

We have reviewed the contents of this publication to ensure consistency with the hardware and software described. Since variance cannot be precluded entirely, we cannot guarantee full consistency. However, the information in this publication is reviewed regularly and any necessary corrections are included in subsequent editions.

# Preface

## Purpose of the manual

The information in this manual enables you to run the ET 200eco PN distributed I/O device on PROFINET IO as IO device.

## Basic knowledge required

This manual presumes a general knowledge in the field of automation engineering.

The manual describes the components based on the data valid at the time of its release. SIEMENS reserves the right of including a product information for each new component, and for each component of a later version.

## Scope of this manual

This manual applies to the ET 200eco PN distributed I/O device.

## Changes compared to the previous version

Compared with the previous version, this manual includes the following changes/additions:

- Updates in section Standards and certifications (Page 100)

## Standards and certifications

You can find information on the standards and approvals that are fulfilled by the ET 200eco PN distributed I/O device in the section Standards and certifications (Page 100).

## Scope of information

In addition to this manual, you need:

- The manual for the IO Controller you are using
- The PROFINET System Description (<https://support.industry.siemens.com/cs/ww/en/view/19292127>) system manual,
- The From PROFIBUS DP to PROFINET IO (<https://support.industry.siemens.com/cs/ww/en/view/19289930>) programming manual.
- The IO-Link System (<https://support.industry.siemens.com/cs/ww/en/view/65949252>) function manual.

## Guide

This manual describes the hardware of the ET 200eco PN distributed I/O device. It consists of instructive sections and reference sections (specifications).

Topics covered in this manual include

- Installation and wiring of the ET 200eco PN distributed I/O device
- Commissioning and diagnostics of the ET 200eco PN distributed I/O device
- Components of the ET 200eco PN distributed I/O system
- Article numbers
- Important terms are explained in the glossary.
- The index helps you to quickly find all texts relevant to your keyword.

## Recycling and disposal

For ecologically compatible recycling and disposal of your old device, contact a certificated waste disposal service for electronic scrap. Dispose of the equipment according to the applicable regulations in your country.

## Training Centers

Siemens offers corresponding courses to get you started with your ET 200eco PN distributed I/O device and the SIMATIC S7 automation system. Please contact your local training center.

Additional information can be found on the Internet ([http://www.sitrain.com/index\\_en.html](http://www.sitrain.com/index_en.html)).

## Technical Support

Expert advice on technical questions with a wide range of demand-optimized services for all our products and systems.

You can find Technical Support at the following address on the Internet (<https://support.industry.siemens.com/cs/ww/en/sc/2090>).

## Additional support

If you have any further questions about the use of products described in this manual, and do not find the right answers there, contact your local Siemens representative:

You can find your representative on the Internet (<http://www.automation.siemens.com/partner/guiwelcome.asp?lang=en>).

A guide to the technical documentation for the various SIMATIC products and systems is available on the Internet (<https://support.industry.siemens.com>).

The online catalog and ordering systems are available on the Internet (<http://mall.industry.siemens.com>).

## See also

Back-up oriented shutdown of ET 200eco PN standard modules (Page 276)

General rules and regulations for operating an ET 200eco PN (Page 29)

I/O device analog input (Page 163)

## Security information

Siemens provides products and solutions with industrial security functions that support the secure operation of plants, systems, machines and networks.

In order to protect plants, systems, machines and networks against cyber threats, it is necessary to implement – and continuously maintain – a holistic, state-of-the-art industrial security concept. Siemens' products and solutions constitute one element of such a concept.

Customers are responsible for preventing unauthorized access to their plants, systems, machines and networks. Such systems, machines and components should only be connected to an enterprise network or the internet if and to the extent such a connection is necessary and only when appropriate security measures (e.g. firewalls and/or network segmentation) are in place.

For additional information on industrial security measures that may be implemented, please visit (<https://www.siemens.com/industrialsecurity>).

Siemens' products and solutions undergo continuous development to make them more secure. Siemens strongly recommends that product updates are applied as soon as they are available and that the latest product versions are used. Use of product versions that are no longer supported, and failure to apply the latest updates may increase customers' exposure to cyber threats.

To stay informed about product updates, subscribe to the Siemens Industrial Security RSS Feed visit (<https://www.siemens.com/industrialsecurity>).

# Table of contents

	<b>Preface</b> .....	<b>3</b>
<b>1</b>	<b>Product overview</b> .....	<b>10</b>
1.1	Distributed I/O device – Overview .....	10
1.2	ET 200eco PN Distributed I/O Device .....	12
<b>2</b>	<b>Installing</b> .....	<b>20</b>
2.1	Installation without mounting rail .....	20
2.2	Installation with mounting rail .....	24
2.3	Mounting position, mounting dimensions .....	24
2.4	Installing the terminal block.....	25
2.5	Replacing labels .....	27
2.6	Removing ET 200eco PN .....	28
<b>3</b>	<b>Wiring</b> .....	<b>29</b>
3.1	General rules and regulations for operating an ET 200eco PN .....	29
3.2	Operating ET 200eco PN on grounded mains.....	30
3.3	Electrical configuration of ET 200eco PN .....	33
3.4	Technical specifications of the cables .....	34
3.5	Wiring the ET 200eco PN.....	35
3.5.1	Wiring the ET 200eco PN to functional earth (FE) .....	35
3.5.2	Wiring I/O devices .....	37
3.6	Pin assignment of connectors .....	40
3.6.1	Pin assignment of the PROFINET connector .....	40
3.6.2	Pin assignment for feeding and looping the voltage .....	41
3.6.3	Pin assignment of digital inputs .....	42
3.6.4	Pin assignment of digital outputs .....	45
3.6.5	Pin assignment for parameterizable digital input/digital output.....	49
3.6.6	Pin assignment for IO-Link Masters.....	50
3.6.7	Pin assignment for analog inputs .....	53
3.6.8	Pin assignment M12 compensation connector for thermocouples .....	58
3.6.9	Pin assignment for analog output .....	59
3.7	Wiring the terminal block.....	60
3.8	Wiring the voltage distributor.....	64
3.9	Looping PROFINET and the supply voltage.....	67

<b>4</b>	<b>Configuring</b> .....	<b>68</b>
4.1	Configuring ET 200eco PN .....	68
4.2	Configuring an IO-Link master.....	69
4.2.1	Configuring the IO-Link Master 6ES7148-6JA00-0AB0 .....	69
4.2.2	Configuring the IO-Link Master 6ES7148-6JD00-0AB0 .....	71
4.3	Device names for ET 200eco PN .....	72
4.4	Ports of ET 200eco PN .....	73
4.5	Isochronous real-time communication .....	74
4.6	Prioritized startup .....	75
4.7	Device replacement without programming device.....	75
4.8	Media redundancy .....	76
4.9	Reset to factory settings (PROFINET).....	76
4.10	SNMP .....	77
<b>5</b>	<b>Commissioning</b> .....	<b>78</b>
5.1	Commissioning ET 200eco PN .....	78
<b>6</b>	<b>Maintenance</b> .....	<b>80</b>
6.1	Replacing the fuse .....	80
6.2	Online firmware update by means of STEP 7 Manager .....	81
6.3	Acyclic data exchange with the IO-Link library .....	83
6.4	Exchange object .....	83
6.5	Maintenance and repair .....	84
6.6	Cleaning the I/O device .....	84
<b>7</b>	<b>Interrupt, error, and system messages</b> .....	<b>85</b>
7.1	Interrupts of ET 200eco PN.....	85
7.2	Maintenance interrupts.....	86
7.3	Diagnostics by means of LED display .....	87
7.3.1	Diagnostics using the LED display on the I/O devices.....	87
7.3.2	Diagnostics using LED display on the IO-Link masters .....	89
7.3.3	Diagnostics using the LED display at the voltage distributor .....	92
7.4	Diagnostics messages of the I/O devices .....	93
7.5	Diagnostics with STEP 7 .....	93
7.5.1	Reading diagnostics data .....	93
7.5.2	Channel diagnostics.....	94
7.5.3	Error classes for I/O devices .....	95
7.5.4	STOP of the IO Controller and recovery of the IO Device.....	99

<b>8</b>	<b>General technical data .....</b>	<b>100</b>
8.1	Standards and certifications .....	100
8.2	EMC compatibility, shipping and storage conditions .....	106
8.3	Mechanical and climatic environmental conditions.....	108
8.4	Specification of dielectric tests, protection class, degree of protection, and rated voltage of ET 200eco PN .....	111
8.5	Safety-relevant symbols for the ET 200eco PN distributed I/O system .....	112
8.6	Use of the ET 200eco PN in zone 2/zone 22 hazardous areas .....	113
<b>9</b>	<b>I/O device digital inputs/digital outputs .....</b>	<b>115</b>
9.1	I/O device digital inputs.....	115
9.1.1	I/O device 8 DI DC 24 V 4xM12 .....	115
9.1.2	I/O device 8 DI DC 24 V 8xM12 .....	120
9.1.3	I/O device 16 DI DC 24 V 8xM12 .....	125
9.1.4	Parameter overview digital inputs .....	130
9.2	I/O device digital outputs .....	131
9.2.1	I/O device 8 DO DC 24 V/1.3A 4xM12 .....	131
9.2.2	I/O device 8 DO DC 24 V/0.5A 4xM12 .....	135
9.2.3	I/O device 8 DO DC 24 V/1.3A 8xM12 .....	139
9.2.4	I/O device 8 DO DC 24V/2.0A 8xM12 .....	144
9.2.5	I/O device 16 DO DC 24 V/1.3A 8xM12 .....	149
9.2.6	Parameter overview digital outputs .....	154
9.3	I/O device digital inputs/digital outputs.....	156
9.3.1	I/O device 8 DIO DC 24V/1.3A 8xM12 .....	156
9.3.2	Parameter overview digital inputs/digital outputs .....	162
<b>10</b>	<b>I/O device analog input/analog output.....</b>	<b>163</b>
10.1	I/O device analog input .....	163
10.1.1	I/O device 8 AI 4 U/I + 4 RTD/TC 8xM12 .....	163
10.1.2	8 AI RTD/TC 8xM12 I/O device .....	172
10.1.3	Parameter overview analog input.....	180
10.1.4	Parameter description analog input.....	186
10.1.5	Analog value representation for measuring ranges with SIMATIC S7 .....	192
10.1.6	Measuring ranges of the analog input device in S7 format.....	193
10.1.7	Dynamic reference temperature with module 8 AI RTD/TC 8xM12.....	200
10.2	I/O device analog output.....	205
10.2.1	I/O device 4 AO U/I 4xM12 .....	206
10.2.2	Parameter overview analog output .....	212
10.2.3	Parameter description analog output .....	213
10.2.4	Output ranges of analog output device .....	215
10.3	Influence of the range of values.....	216



<b>11</b>	<b>IO-Link Master</b> .....	<b>218</b>
11.1	IO-Link Master (6ES7148-6JA00-0AB0).....	218
11.1.1	Parameters for IO-Link Master .....	226
11.1.2	Functions .....	228
11.2	IO-Link Master (6ES7148-6JD00-0AB0).....	229
11.2.1	Configuration .....	233
11.2.2	Parameter.....	234
11.2.3	Explanation of the parameters .....	235
11.2.4	Functions .....	237
11.2.5	Interrupts .....	239
11.2.5.1	Triggering of a diagnostic interrupt .....	240
11.2.5.2	Triggering a hardware interrupt .....	240
11.2.5.3	Triggering of a pull/plug interrupt .....	240
11.2.6	Maintenance events.....	241
<b>12</b>	<b>Terminal block and voltage distributor</b> .....	<b>242</b>
12.1	Terminal block .....	242
12.2	Voltage distributor .....	244
<b>A</b>	<b>Signal names</b> .....	<b>247</b>
A.1	Signal names .....	247
<b>B</b>	<b>Article numbers</b> .....	<b>248</b>
<b>C</b>	<b>Dimensional drawings</b> .....	<b>254</b>
C.1	Dimensional drawings .....	254
<b>D</b>	<b>Connection examples</b> .....	<b>261</b>
D.1	Connection of resistance thermometers to the analog inputs.....	261
D.2	Connection of thermocouples to the analog inputs.....	262
<b>E</b>	<b>I/O address space</b> .....	<b>265</b>
<b>F</b>	<b>Response times for analog input device and output device</b> .....	<b>273</b>
F.1	Response times for analog input device.....	273
F.2	Response times for analog output device .....	274
<b>G</b>	<b>Fail-safe shutdown of ET 200eco PN standard modules</b> .....	<b>276</b>
G.1	Back-up oriented shutdown of ET 200eco PN standard modules .....	276
<b>H</b>	<b>Open Source Software</b> .....	<b>279</b>
	<b>Glossary</b> .....	<b>281</b>
	<b>Index</b> .....	<b>289</b>

# Product overview

## 1.1 Distributed I/O device – Overview

### Distributed I/O systems – application area

A plant configuration quite often features a process I/O configuration in a central automation system.

The wiring of process I/O components installed at a grated distance away from an automation system may soon become highly complex and susceptible for electromagnetic interference.

Distributed I/O systems are the perfect solution for such configurations.

- The controller CPU is located in a central rack.
- The I/O systems (inputs and outputs) are operated locally in a distributed configuration.

### What is PROFINET IO?

PROFINET IO is an open transmission system with real-time functionality defined in accordance with the PROFINET standard. This standard defines a manufacturer-independent communication, automation and engineering model.

Industrial-strength connections are available for wiring the PROFINET components.

- PROFINET discards the hierarchical PROFIBUS master/slave concept. and deploys a provider/consumer principle instead. The IO Devices that will be subscribed to by an IO Controller are defined within the planning phase.
- The quantity structures are extended in accordance with the available quantities for PROFINET IO. Parameter limits are not exceeded during configuration.
- The transmission rate is 100 Mbps.
- The configuration interface for users is generally the same as that for PROFIBUS DP (the system is configured in **STEP 7 > HW Config**).

### Structure of a PROFINET IO network

The figure below illustrates a typical PROFINET IO network structure. Existing PROFIBUS slaves can be integrated using an IE/PB Link.

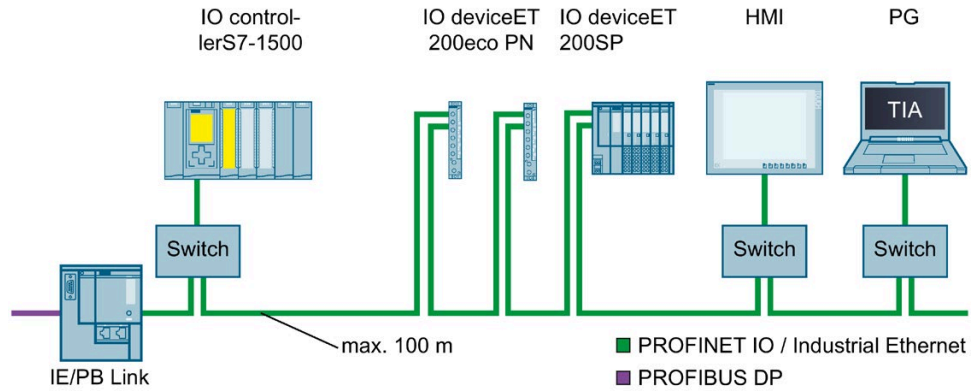

Figure 1-1 Typical structure of PROFINET IO

## 1.2 ET 200eco PN Distributed I/O Device

### Definition

The ET 200eco PN distributed I/O device is a compact PROFINET IO device in degree of protection IP65/66 or IP67 and UL Enclosure Type 4x, Indoor use only.

### Field of application

The fields of application of the ET 200eco PN are derived from its special properties.

- A robust design and degree of protection IP65/66 or IP67 make the ET 200eco PN distributed I/O device suitable in particular for use in rugged industrial environments.
- The compact design of the ET 200eco PN is particularly favorable for applications in confined areas.
- The easy handling of ET 200eco PN facilitates efficient commissioning and maintenance.

### Properties

The ET 200eco PN has the following properties:

- Integrated switch with 2 ports
- Supported Ethernet services:
  - ping
  - arp
  - Network diagnostics (SNMP)
  - LLDP
  - DCP
- Interrupts
  - Diagnostics interrupts
  - Maintenance interrupts
  - Hardware interrupts
- Port diagnostics
- Isochronous real-time communication
- Prioritized startup
- Device replacement without programming device
- Media redundancy

## Components of ET 200eco PN

The tables below provide an overview of the most important components of ET 200eco PN:

Table 1- 1 Components of ET 200eco PN (30 mm)

Component	Function	Figure
I/O device	<p>You connect the sensors and actuators to the I/O device. The I/O device is available in the following variants:</p> <ul style="list-style-type: none"> <li>• 8 DI DC 24V 4×M12</li> <li>• 8 DO DC 24V/1,3A 4×M12</li> <li>• 8 DO DC 24V/0,5A 4×M12</li> </ul>	

① SF/MT LED

② BF LED

③ ON LED

④ DC 24V LED (for digital output device only)

⑤ P1 LK LED

⑥ P2 LK LED

⑦ Channel status/channel fault

⑧ X03: Voltage infeed

⑨ X02: Loop through of the voltage

⑩ Input/output signal

⑪ MAC address

⑫ X01 P2 R LAN: PROFINET IO connection

⑬ X01 P1 R LAN: PROFINET IO connection

Table 1-2 Components of ET 200eco PN (60 mm)

Component	Function	Figure
I/O device	<p>You connect the sensors and actuators to the I/O device. The I/O device is available in the following variants:</p> <ul style="list-style-type: none"> <li>• 8 DI DC 24V 8×M12</li> <li>• 16 DI DC 24V 8×M12</li> <li>• 8 DO DC 24V/1,3A 8×M12</li> <li>• 8 DO DC 24V/2,0A 8×M12</li> <li>• 16 DO DC 24V/1,3A 8×M12</li> <li>• 8 AI 4 U/I + 4 RTD/TC 8×M12</li> <li>• 8 AI RTD/TC 8×M12</li> <li>• 8 DIO DC 24V/1,3A 8×M12</li> </ul>	

- |   |  |
|---|--|
| ① SF/MT LED                                   | ⑧ X03: Voltage infeed                  |
| ② BF LED                                      | ⑨ X02: Loop through of the voltage     |
| ③ ON LED                                      | ⑩ Input/output signal                  |
| ④ DC 24V LED (for digital output device only) | ⑪ MAC address                          |
| ⑤ P1 LK LED                                   | ⑫ X01 P2 R LAN: PROFINET IO connection |
| ⑥ P2 LK LED                                   | ⑬ X01 P1 R LAN: PROFINET IO connection |
| ⑦ Channel status/channel fault                |  |

Table 1- 3 Components of ET 200eco PN (60 mm)

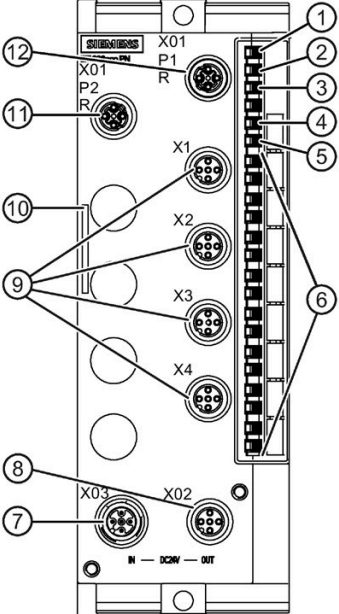
Component	Function	Figure
I/O device	You connect the sensors and actuators to the I/O device. The I/O device is available in the following variants: <ul style="list-style-type: none"> <li>• 4 AO U/I 4×M12</li> </ul>	

- |                                |  |
|--------------------------------|--|
| ① SF/MT LED                    | ⑦ X03: Voltage infeed                  |
| ② BF LED                       | ⑧ X02: Loop through of the voltage     |
| ③ ON LED                       | ⑨ Input/output signal                  |
| ④ P1 LK LED                    | ⑩ MAC address                          |
| ⑤ P2 LK LED                    | ⑪ X01 P2 R LAN: PROFINET IO connection |
| ⑥ Channel status/channel fault | ⑫ X01 P1 R LAN: PROFINET IO connection |

### What is an IO-Link Master?

IO-Link is a point-to-point connection to conventional and intelligent sensors/actuators via unshielded standard cable in proven 3- or 5-conductor technology. IO-Link Masters are backwards compatible with all DI standard sensors. Switching state and data channel designed in proven 24 VDC technology.

Supports mixed operation of sensors/actuators in the IO-Link, digital input and digital output operating modes on all four ports of the IO-Link Master.

Table 1-4 IO-Link Master (6ES7148-6JA00-0AB0)

Component	Function	Figure
IO-Link master	Connect the following to I/O device: <ul style="list-style-type: none"> <li>X1 to X4: IO-Link Devices or sensors/actuators</li> <li>X5, X6: Sensors</li> <li>X7, X8: Actuators</li> </ul>	

- ① SF/MT LED
- ② BF LED
- ③ ON LED
- ④ DC 24V LED
- ⑤ P1 LK LED
- ⑥ P2 LK LED
- ⑦ Status display / Communication
- ⑧ Digital input: Channel status/channel fault
- ⑨ Digital output: Channel status/channel fault
- ⑩ X03: Voltage infeed
- ⑪ X02: Loop through of the voltage
- ⑫ X7/X8: Output signal
- ⑬ X5/X6: Input signal
- ⑭ MAC address
- ⑮ X1 to X4: IO-Link ports/input signal
- ⑯ X01 P2 R LAN: PROFINET IO connection
- ⑰ X01 P1 R LAN: PROFINET IO connection



Table 1- 5 IO-Link Master (6ES7148-6JD00-0AB0)

Component	Function	Figure
IO-Link master	Connect IO-Link devices or encoders/actuators to the I/O device.	

- |   |   |
|---|---|
| ① SF/MT LED                                 | ⑧ IO-L1 ... IO-L4: Channel status/channel fault IO-Link communication |
| ② BF LED                                    | ⑨ X03: Voltage infeed   |
| ③ ON LED                                    | ⑩ X02: Loop through of the voltage                                    |
| ④ DC 24V LED                                | ⑪ X1 to X4: IO-Link ports   |
| ⑤ P1 LK LED                                 | ⑫ MAC address   |
| ⑥ P2 LK LED                                 | ⑬ X01 P2 R LAN: PROFINET IO connection                                |
| ⑦ Q1 ... Q4: Channel status in the SIO mode | ⑭ X01 P1 R LAN: PROFINET IO connection                                |

## LEDs

For information on the meaning of the LED displays, see section Diagnostics by means of LED display (Page 87).

Further components of ET 200eco PN

Table 1- 6 Further components of ET 200eco PN

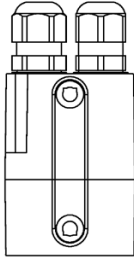
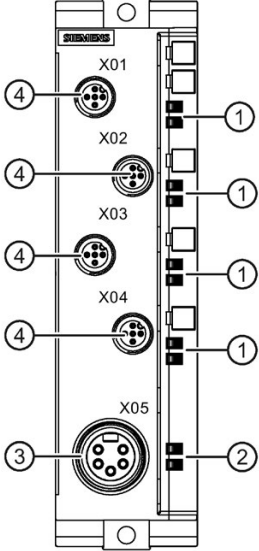
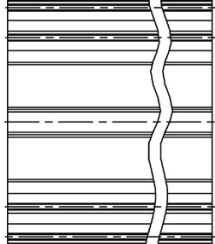
Component	Function	Figure
Terminal block	You can connect up to 10 A per voltage to the terminal block for distribution to the I/O devices. A maximum of 4 A per voltage is available short-circuit protected for each I/O device.	
Voltage distributor	You can supply up to 8 A per voltage at the PD DC 24V 1×7/8" 4×M12 and distribute up to 4 A per voltage and connector short-circuit-protected through 4 connectors.	 <p data-bbox="991 1300 1422 1427">                     ① LEDs for forwarding 1L/2L                      ② LEDs for forwarding 1L/2L                      ③ X05: Status of voltage supply                      ④ X01 ... X04: Loop through of the voltage                 </p>
Mounting rail	You can install several I/O devices on the mounting rail.	

## IO Controller

The ET 200eco PN can communicate with all IO controllers that conform to IEC 61158.

At least STEP 7 V5.4, SP4 is required to configure a ET 200eco PN.

The ET 200eco PN can be configured starting from a CPU with extended diagnostics, see FAQ (<https://support.automation.siemens.com/WW/view/en/23678970>).

For information on the individual PROFINET properties that are available for the respective versions of the ET 200eco PN, refer to theFAQ (<https://support.automation.siemens.com/WW/view/en/44383954>).

# Installing

## Two installation variants

There are two installation variants:

- With mounting rail
- Without mounting rail

For corresponding conditions, refer to the next chapters.

## 2.1 Installation without mounting rail

### Simple installation

The ET 200eco PN distributed I/O device is designed for easy installation.

- The I/O device must be mounted on a solid base
- and can be prewired.

### Requirements

Screw type	Explanation
Cylinder head screw M5 to ISO 1207/ISO 1580 (DIN 84/DIN85)	The minimum screw length amounts to 35 mm. Any washers you might need should conform to DIN 125.
Hexagon socket head cap screws M5 to DIN EN ISO 4762	

### Tools required

Medium-sized screwdriver or 4 mm hex socket driver.

## Procedure

1. Screw the I/O device onto a level surface.

Screw the I/O device onto the panel at both mounting fixtures on the top and bottom of the front or side (torque: 3 N/m).

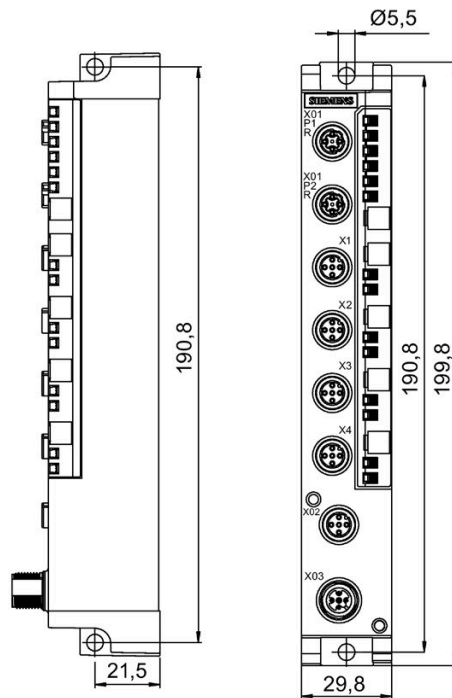

Figure 2-1 Mounting the I/O device on a panel (30 mm)

2.1 Installation without mounting rail

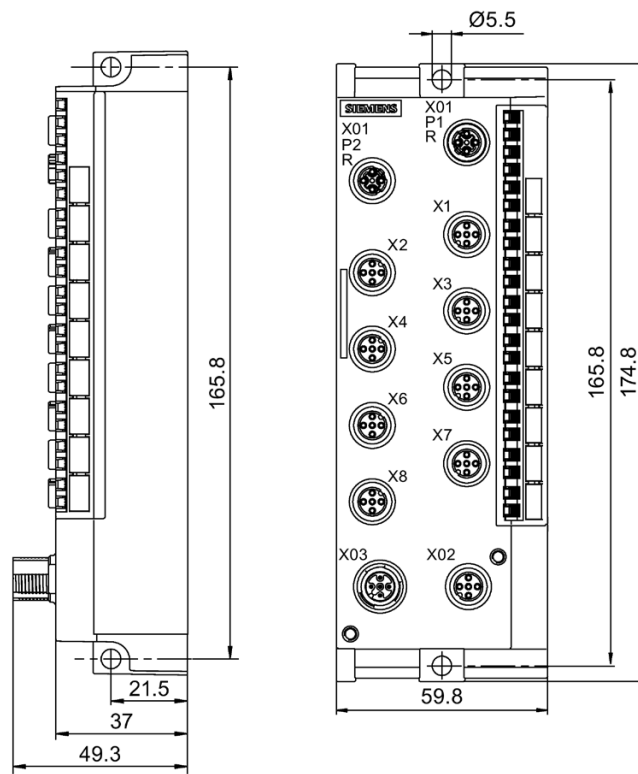

Figure 2-2 Mounting the I/O device on a panel (60 mm), for example 16 DO DC 24V/1,3A 8×M12

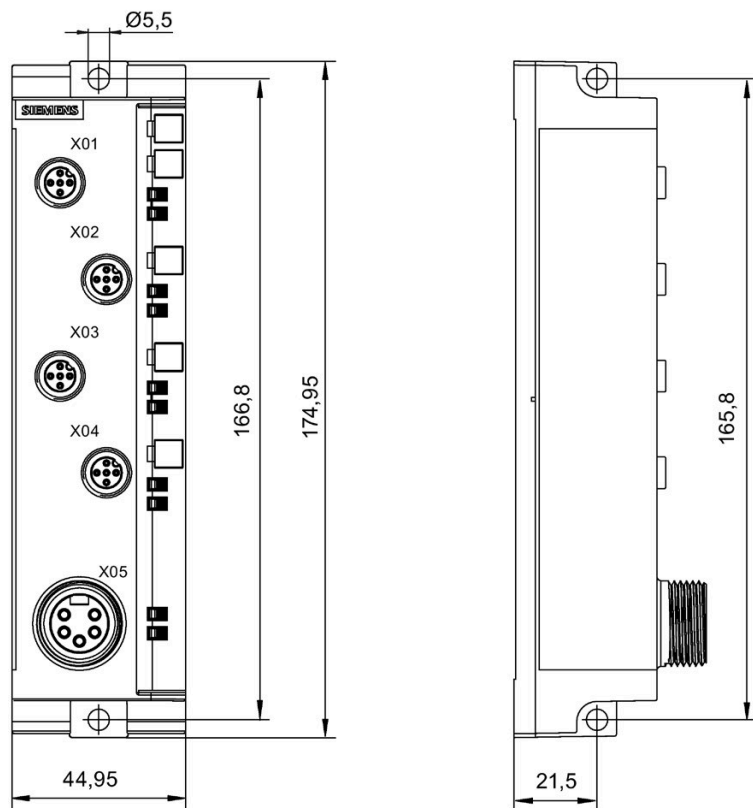

Figure 2-3 Mounting the PD DC 24V 1×7/8" 4×M12 on a panel (45 mm)

## 2.2 Installation with mounting rail

### Version

The mounting rail is available with a length of 500 mm.

### Installing the mounting rail

Cut the 500-mm rail to suit your requirements and drill mounting holes for the M8 screws. You should distribute the mounting holes evenly at a pitch of 182 mm on the rail, starting at a distance of 12 mm from the edge.

Use the rack screw to bolt the I/O devices onto the mounting rail.

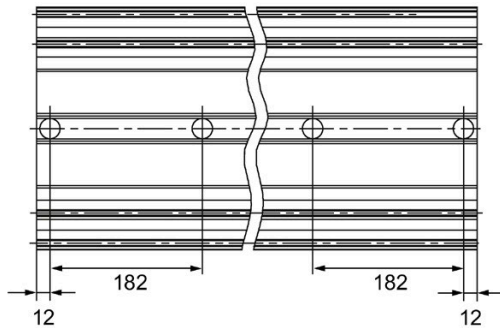

Figure 2-4 Installing the mounting rail

## 2.3 Mounting position, mounting dimensions

### Mounting position

The ET 200eco PN can be mounted in any position.

### Mounting and clearance dimensions

Table 2-1 Mounting dimensions

	Dimensions	
	single width	double width
Mounting width	30 mm	60 mm
Mounting height	200 mm	175 mm
Mounting depth	49 mm	49 mm



## 2.4 Installing the terminal block

### Properties

The terminal block connects the ET 200eco PN and supplies the I/O device with power.

The terminal block

- can be installed separately,
- or be screwed on to each I/O device.

### Requirements

Note that you must wire the terminal block before you install it.

### Tools required

Recessed head screwdriver, medium size

### Installing the terminal block separately

You install the terminal block separately.

Remove the screws and then screw them in again at the bottom of the housing.

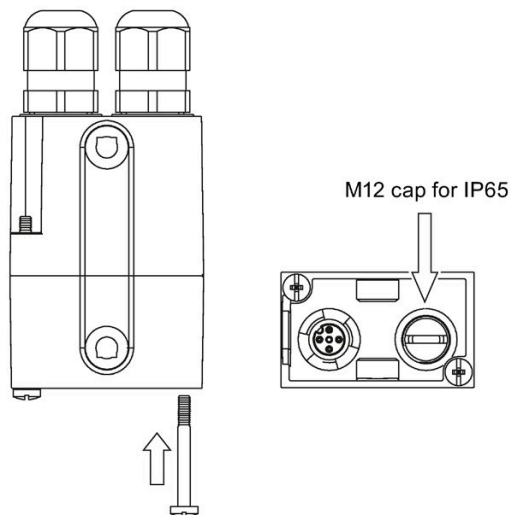

Figure 2-5 Installing the terminal block separately

### Installing the terminal block on an I/O device

Install the terminal block vertically on a housing of 30 mm width, or horizontally on a housing of 60 mm width.

An M12 cap is attached to the bottom of the terminal block to implement the corresponding degree of protection. Make sure that the M12 cap is not attached to the terminal block connector and that it is mounted onto connector X02 of the I/O device. Bolt the terminal block onto the I/O device by tightening the screws.

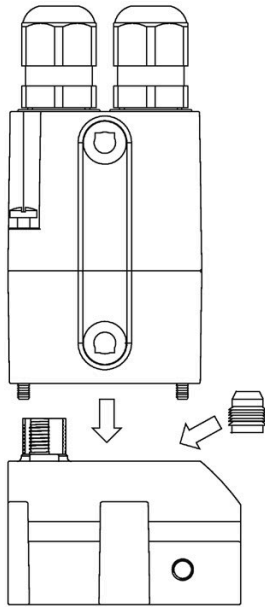

Figure 2-6 Installing the terminal block on an I/O device of 60 mm width

### See also

Wiring the terminal block (Page 60)

Terminal block and voltage distributor (Page 242)

## 2.5 Replacing labels

### Properties

You can identify the I/O device and the I/O connectors using the labels. The module is supplied with the labels already clipped into the holder.

- 1 for the I/O device
- 4 or 8 for the I/O connectors

### Requirements

You can order replacement labels.

### Tools required

2.5 to 4 mm slotted screwdriver

### Replacing labels

1. Push the screwdriver into the small opening of the label at an angle and then lever it out.

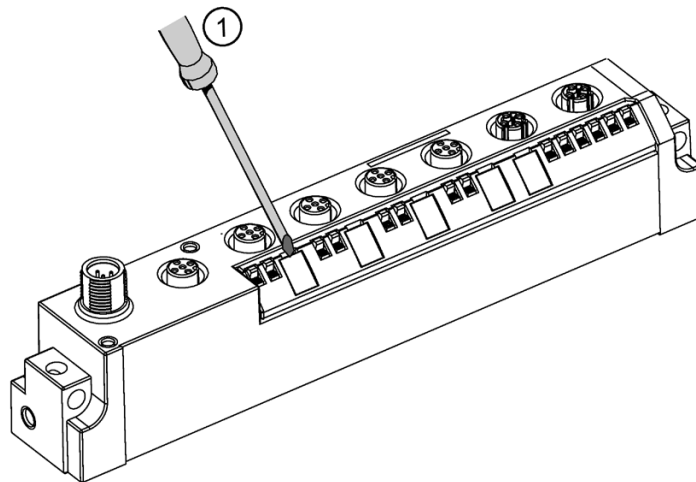

Figure 2-7 Removing labels

2. Push the new label into the holder on the device.

## 2.6 Removing ET 200eco PN

### Procedure

The ET 200eco PN is wired up and operating.

1. Switch off the supply voltage to the ET 200eco PN.
2. Disconnect the wiring from the I/O device.
3. Remove the fixing screws from the I/O device.

---

### Note

Observe the information in chapter Looping PROFINET and the supply voltage (Page 67) when replacing the I/O device.

---

# Wiring

## 3.1 General rules and regulations for operating an ET 200eco PN

### Introduction

When installing the ET 200eco PN distributed I/O device as part of a plant or system, special rules and regulations need to be adhered to depending on the area of application.

This section provides an overview of the most important rules you have to observe when integrating the ET 200eco PN distributed I/O device in a plant or system.

### EMERGENCY-STOP devices

EMERGENCY-STOP devices in accordance with IEC 204 (corresponds to DIN VDE 113) must remain effective in all operating modes of the plant or system.

### System startup after certain events

The table below identifies situations you must pay attention to when the system starts up after the occurrence of certain events.

If ...	then ...
Startup follows a power dip / failure The ET 200eco PN is started up after bus communication has been interrupted	Dangerous states must not result. If necessary, EMERGENCY-STOP must be enforced!
Start-up follows unlocking of the emergency stop device	An uncontrolled or undefined start up must not occur.

### External fuses/switches

External fuses and switches must be installed so that they meet the standards for cable and device protection applicable to your application.

### 24 V DC supply

The following table identifies requirements you must observe for the 24 V DC supply.

With ...	You must take into account...	
Buildings	External lightning protection	Take lightning protection measures (for example, lightning protection elements)
24 V DC supply lines, signal lines	Internal lightning protection	
24 V DC supply	Safe (electrical) isolation of the extra-low voltage (SELV/PELV)	
Looping-through of the supply voltage	Voltage drop in the case of loop-through (see Chapter Looping PROFINET and the supply voltage (Page 67))	

### Protection against external electrical influences

The table below identifies to what you must pay attention when protecting against electrical influences or faults.

With ...	You must take into account...
all plants or systems in which the ET 200eco PN is installed	The plant or system is EMC-compatible and properly grounded for the discharge of electromagnetic interference.
Supply, signal and bus lines	The wiring arrangement and installation must be correct.
Signal and bus lines	A cable or wire break must not lead to undefined states of the plant or of the system.

## 3.2 Operating ET 200eco PN on grounded mains

### Introduction

This section provides information about the overall configuration of an ET 200eco PN distributed I/O device with a grounded power system (TN-S system). The topics covered in this section are in particular: Disconnecting devices, short-circuit and overload protection in accordance with DIN VDE 0100 and DIN EN 60204-1.

### Supply voltages of the ET 200eco PN

There are 2 voltage supplies:

- 1L+: Non-switched supply voltage (electronics/encoder/load voltage supply)
- 2L+: Switched voltage supply (load voltage supply)

### Definition: Grounded power supply

For grounded power supplies the neutral conductor of the supply system is grounded. A short-circuit to ground of a live conductor, or of a grounded part of the system, trips the protective devices.

### Safe electrical separation (SELV in accordance with IEC 61131-2 or IEC 61010-2-201)

Load power supplies/power supply modules with 24 V DC output voltage require safe electrical separation and voltage limiting (extra low voltage). Load power supplies/power supply modules with 24 V DC output voltage are not connected to the protective conductor. According to IEC 61131-2 and IEC 61010-2-201, this protection is referred to as SELV (Safety Extra Low Voltage).

The wiring of SELV circuits must be safely separated from the wiring of other circuits that are not SELV, or the insulation of all conductors must be dimensioned for the higher voltage.

### Grounded extra-low voltage (PELV in accordance with IEC 61131-2 or IEC 61010-2-201)

Load power supplies/power supply modules with grounded 24 V DC output voltage require safe connection to the protective conductor and voltage limiting (extra low voltage).

According to IEC 61131-2 and IEC 61010-2-201, this protection is referred to as PELV (Protective Extra Low Voltage).

Either the wiring of PELV circuits must be safely isolated from the wiring of other circuits that are not PELV, or the insulation of all wires must be dimensioned for the higher voltage.

### Components and protective measures

A number of components and protective measures are prescribed for plant installations. The type of components and the degree to which the protective measures are mandatory depend on which DIN VDE regulation applies to your system configuration. The following table refers to the figure below.

Comparison ...	Reference to figure	DIN VDE 0100	DIN EN 60204
Disconnecting device for controller, sensors, and actuators	(1) "Grounding concept for ET 200eco PN"	... Part 460: Main switch	... Part 1: Disconnecter
Short-circuit / overload protection	(2) "Grounding concept for ET 200eco PN"	... Part 725: Single-pole protection of circuits	... Part 1: With grounded secondary circuit: <b>Single-pole</b> protection
Circuit breaker		... Part 430: Protection of cables and wires against overcurrent	-

### Configuring ET 200eco PN with grounded reference potential

In the configuration of the ET 200eco PN with grounded reference potential, any interference currents that occur are discharged to functional ground. The terminals must be connected externally (see the figure "Grounding concept for ET 200eco PN": Connection between 1M and FE).

### Configuring ET 200eco PN with ungrounded reference potential

In the configuration of the ET 200eco PN with ungrounded reference potential, any interference currents that occur are discharged to functional ground via an internal RC network (see in the figure "Grounding concept for ET 200eco PN": **No** connection between 1M and FE).

**Insulation monitoring**

Insulation monitoring must be provided in the following cases:

- When setting up the ET 200eco PN distributed I/O devices with non-grounded reference potential
- If dangerous system states occur due to error

**ET 200eco PN in its overall configuration**

The figure below shows the overall configuration of the ET 200eco PN distributed I/O device (load voltage supply and grounding concept) with supply from a TN-S system.

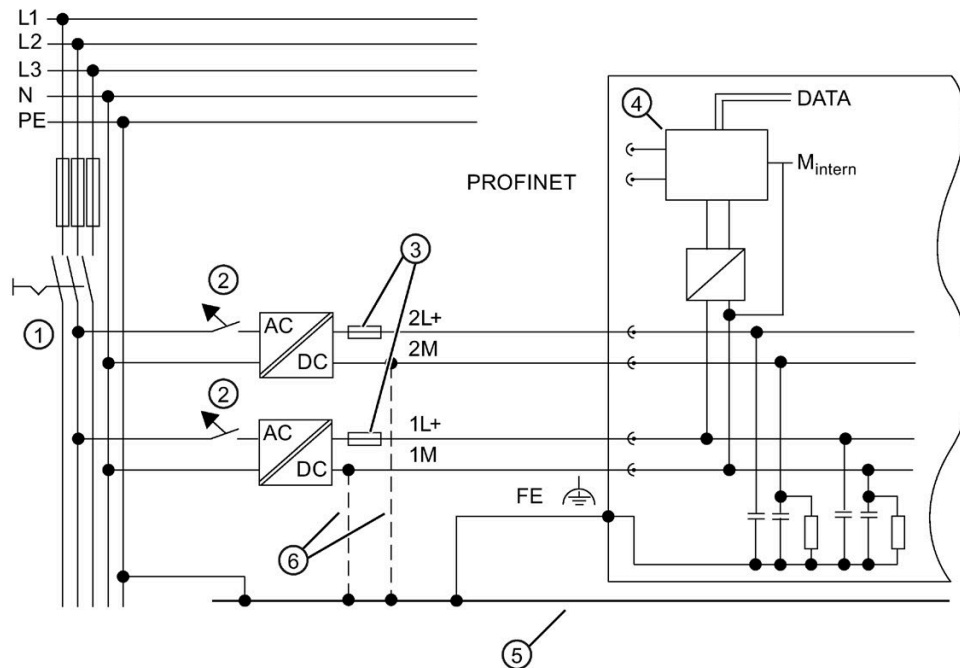

- ① Disconnecting device for controller, sensors, and actuators
- ② Short-circuit / overload protection
- ③ Fuses for line protection
- ④ Microprocessor and switch
- ⑤ Ground bus
- ⑥ When the ET 200eco PN is configured with ungrounded reference potential, the connection between 1M and FE and 2M and FE is not required



### 3.3 Electrical configuration of ET 200eco PN

#### Electrical isolation

The ET 200eco PN electrical configuration features electrical isolation between:

- 1L+ Non-switched supply voltage (electronic/sensor/load supply)  
Electrically isolated from PROFINET IO and 2L+ (load voltage supply)
- 2L+: Switched supply voltage (load voltage supply):  
Electrically isolated from all other circuit components.  
Can be shut down with influencing the 1L+.
- PROFINET IO interface:  
Electrically isolated from all other circuit components.

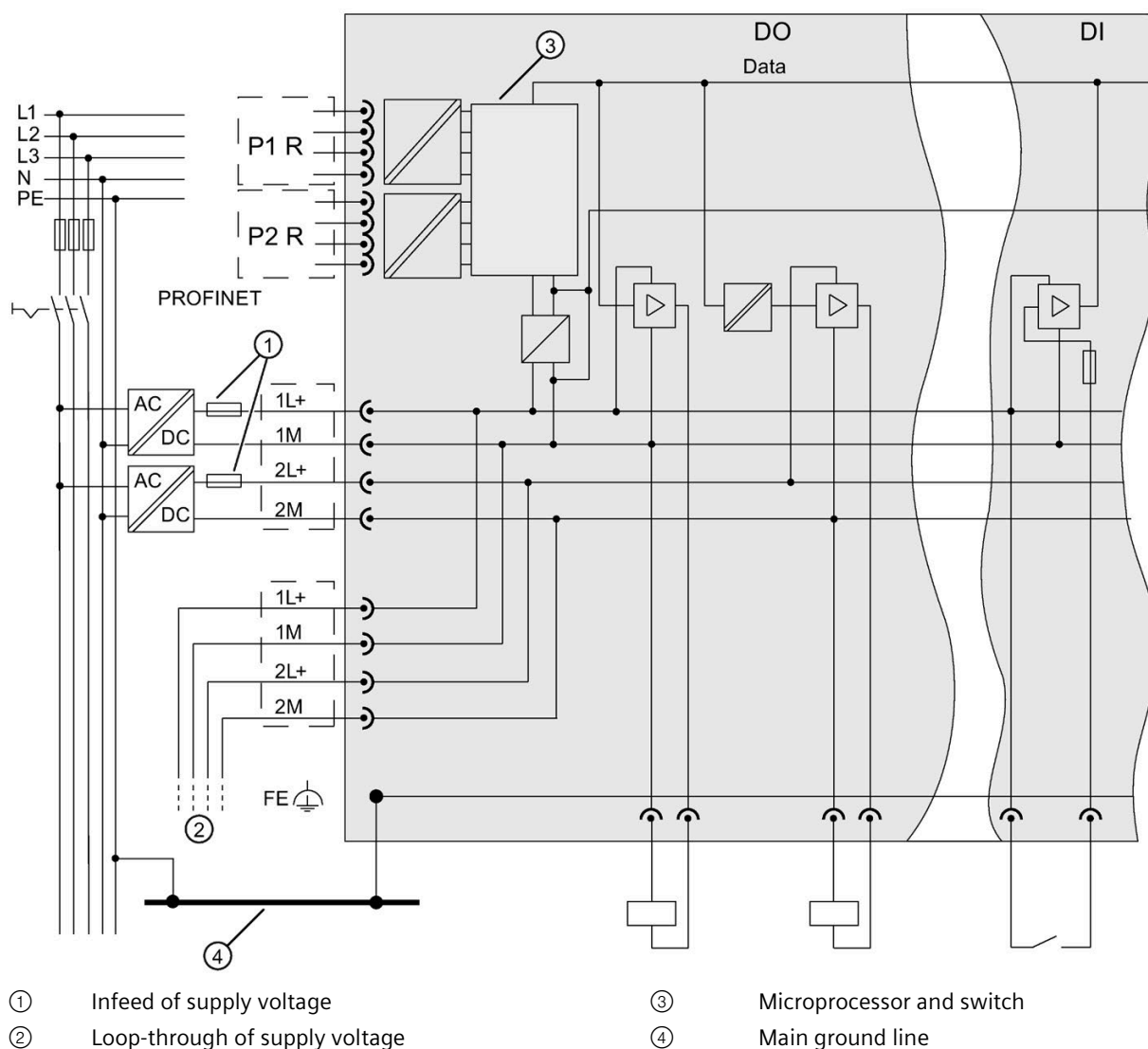

### Connection of a digital output to a digital input

 **WARNING**

When a digital output is connected to a digital output, the respective potential groups have to be observed. Depending on the configuration, 1M and 2M may then be connected, resulting in elimination of the galvanic isolation between 1L+ and 2L+.

### Line protection

Line protection is required in accordance with DIN VDE 0100, i.e., you must always provide external fusing.

The power supplies of the I/O device must be fused using a 24 V DC/4 A miniature circuit breaker with tripping characteristic type B or C.

The power supplies of the terminal block must be fused using a 24 V DC/10 A miniature circuit breaker with tripping characteristic type B or C.

The power supplies of the voltage distributor must be fused using a 24 VDC / 8 A miniature circuit breaker with tripping characteristic type B or C.

## 3.4 Technical specifications of the cables

### Impact of the cable length on the supply voltage

- When you wire your configuration, you must take into account the impact of the cable length on the supply voltage of the ET 200eco PN.

**Example**

When using a 10 m cable with  $\varnothing 0.75 \text{ mm}^2$ , the resistance is  $0.5 \Omega$ ; this is equivalent to a 2 V voltage drop at 4 A.

**Note**

If you do not maintain the maximum feed current and the appropriate cable cross-sections, you will risk overheating of the cable insulation and contacts, and damage to the device.

## 3.5 Wiring the ET 200eco PN

### 3.5.1 Wiring the ET 200eco PN to functional earth (FE)

#### Introduction

You must connect the ET 200eco PN with the functional earth (FE).

#### What is functional ground?

All ET 200eco PN I/O devices have a functional earth connection. This connection is used to suppress interference but not for protective purposes. You establish a direction electrical connection to a point in your plant or a shield using the functional earth connection. EMC interference is discharged directly to earth through this connection. The interference immunity of the entire I/O device is increased by the discharge of the EMC interference.

#### Install ET 200eco PN I/O devices on conductive base

##### Requirements

Conductive base for installation of the I/O device.

##### Procedure

The procedure and further information about the required tools and accessories are described in the Section Installation without mounting rail (Page 20).

---

##### Note

##### Grounding with conductive base

When you fasten an I/O device of ET 200eco PN to a conductive, grounded base, the two module fixing screws create a conductive connection to the ground potential. Make sure there is a low-impedance connection between the peripheral device and the conductive substrate and between the conductive substrate and the functional ground.

---

### Install ET 200eco PN I/O devices on non-conductive base

#### Requirements

Non-conductive base for installation of the I/O device.

#### Tools required

You need the following tools to connect to the functional ground:

- Stripping tool
- Crimp tool
- Screwdriver

#### Required accessories

You need the following accessories to connect to the functional ground:

- M5 x 8 fixing screw and washers
- Grounding cable (copper braid cable) with a minimum cross-section of 4 mm<sup>2</sup>
- Cable lug suitable for M5 screws

#### Installation

To connect ET 200eco PN I/O devices to functional earth with non-conductive base, follow these steps:

- Drill 2 fixing holes.
- Strip the grounding conductor and crimp on the cable lug.
- Screw the cable lug onto the I/O device and voltage distributor (M5 fixing screw) with a torque of 1.5 Nm.

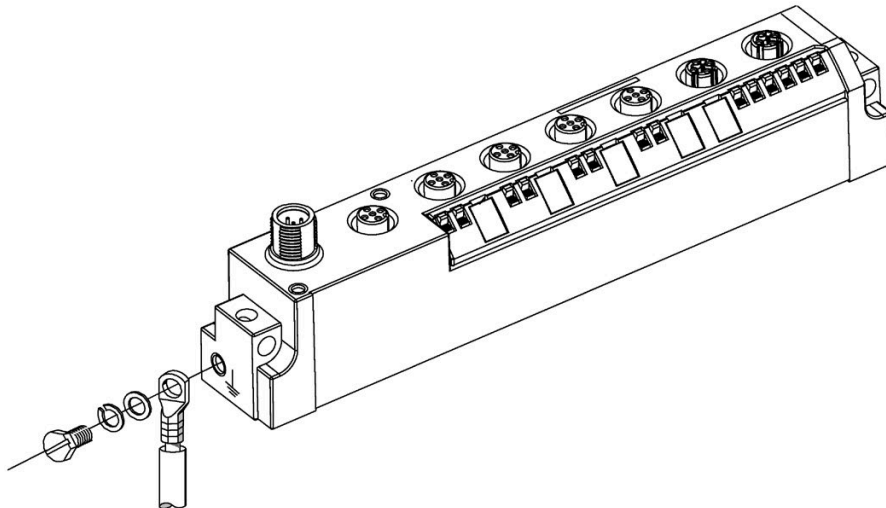

Figure 3-1 Wiring the I/O device to functional earth

#### Reference

For additional information on installing I/O devices, refer to the section Installing (Page 20).

## 3.5.2 Wiring I/O devices

### Properties

Connect the sensors and actuators to the 5-pin M12 circular sockets (X1 to X4, or X1 to X8) on the front panel of the I/O device.

### Requirements

Shut off the supply voltage before you wire the I/O devices.

### Tools required

Stripping tool and screwdriver for wiring the M12 cable connector, if you do not use prefabricated cables.

### Required accessories

- Prefabricated cable with 5-pin M12 cable connector
- or 3-, 4- or 5-wire copper cable, flexible and 5-pin M12 connector (see tables below)
- or a Y cable
- M12 sealing caps

You can find the article numbers in the appendixArticle numbers (Page 248).

### Connecting the M12 connector

1. Plug the connector into the relevant circular socket connector on the I/O block. Make sure the connectors and sockets are properly interlocked (matched joint).
2. Secure the connector by tightening the knurled ring nut with a torque of 1.5 Nm.

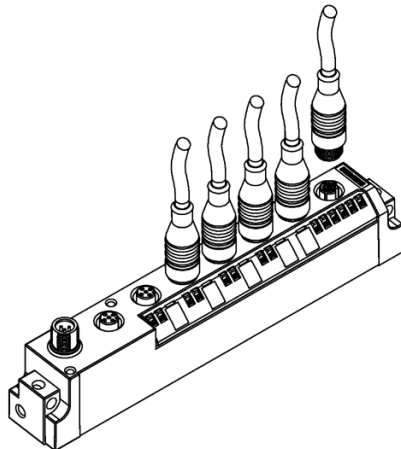

Figure 3-2 Connecting the M12 connector

### Y cable

The Y cable allows you to connect two actuators or sensors to the inputs or outputs of the ET 200eco PN.

The use of the Y cable is particularly recommended when two channels are occupied for each socket of an I/O device. The Y cable distributes the channels to two circular connectors (see figure below for pin assignment).

The wiring of the Y cable is shown below.

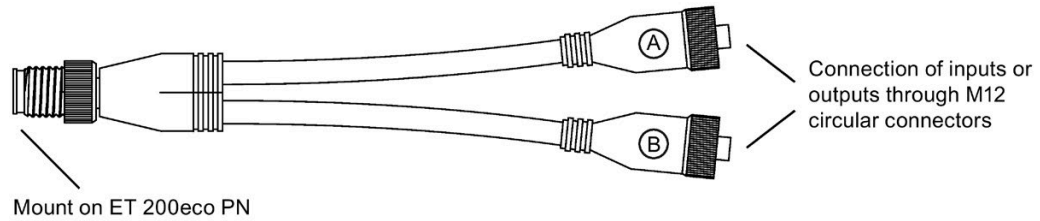
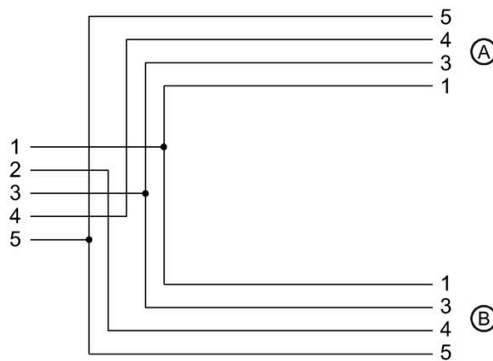

Figure 3-3 Y cable



### Wiring jacks (DI/DQ) for Y cable

To connect digital inputs via a Y cable, you will need:

- A Y cable
- 2 M12 jacks
- A flexible 3-wire or 4-wire copper cable

The assignment of Pin 4 depends on which socket of the ET 200eco PN the Y cable is screwed to.

### Pin assignment of the sockets for inputs/outputs

The pin assignment of the sockets for inputs/outputs can be found in the data for the individual I/O devices starting in section Pin assignment of digital inputs (Page 42).

## Wiring M12 jacks for analog inputs and analog outputs

For the connection of analog inputs and outputs, you will need:

- one 4-pin or 5-pin M12 jack
- a shielded 4-wire copper cable with a wire cross-section of  $\leq 0.75 \text{ mm}^2$

Wire the jack according to the pin assignment of the sockets on the I/O device. You can find the pin assignment in the data for the individual I/O devices starting in Chapter Pin assignment for analog inputs (Page 53).

---

### Note

#### Coupler plug for RTD measurement

For RTD measurements, use a coupler plug with gold-plated contacts. Other materials can create contact resistance that can result in incorrect measured values.

---

## Sealing round sockets not in use

Always seal all unused round sockets using M12 sealing caps to achieve degree of protection IP65, IP66 or IP67.

You can find the article numbers in the appendixArticle numbers (Page 248).

## Pin assignment

The pin assignment of the I/O devices is specified in the following chapters.

### 3.6 Pin assignment of connectors

#### 3.6.1 Pin assignment of the PROFINET connector

##### PROFINET connector, X01 connector, port 1 and port 2

The tables below list the pin assignment for the PROFINET connectors.

Table 3- 1 Pin assignment of the M12 cable connector for PROFINET connector, ports 1 and 2

Pin	Assignment	View of the cable connector (PROFINET), port 1 and port 2
	<b>Assignment X01 P1 R</b>	
1	TXP	
2	RXP	
3	TXN	
4	RXN	
Thread	Functional earth FE	
	<b>Assignment X01 P2 R</b>	
1	RXP	
2	TXP	
3	RXN	
4	TXN	
Thread	Functional earth FE	

**Note**

When you deactivate the "Autonegotiation" function in *STEP 7* , you must observe the different assignment of the pins at X01 P1 R and X01 P2 R.



### 3.6.2 Pin assignment for feeding and looping the voltage

#### Cable connector for supply voltage infeed, X03 connector

The table below lists the pin assignment for the supply voltage infeed.

Table 3- 2 Pin assignment of the M12 cable connector for the supply voltage infeed

Pin	Assignment	View of the cable connector (wiring side)
1	Supply voltage 1L+ (non-switched)	
2	Ground 2M (switched)	
3	Ground 1M (non-switched)	
4	Supply voltage 2L+ (switched)	
5	Reserved	

#### Cable connector for loop-through of the supply voltage, X02 socket

The following table lists the supply voltage for loop-through of the supply voltage.

Table 3- 3 Pin assignment of the M12 cable connector for loop-through of the voltage

Pin	Assignment	View of the cable connector (wiring side)
1	Supply voltage 1L+ (non-switched)	
2	Ground 2M (switched)	
3	Ground 1M (non-switched)	
4	Supply voltage 2L+ (switched)	
5	Reserved	

**Note**

The M12 sockets for the supply and I/O have the same coding.  
 Make sure that you wire the supply and the I/O correctly.

 <b>CAUTION</b>
<b>PROFINET IO</b> Modules with PROFINET interfaces may only be operated when all connected nodes are supplied with SELV/PELV voltages.

### 3.6.3 Pin assignment of digital inputs

#### I/O device 8 DI DC 24V 4×M12 (6ES7141-6BF00-0AB0)

You will find the pin assignment for the 8 DI DC 24V 4×M12 I/O device in the table below.

Table 3- 4 Pin assignment of the M12 cable connector for the 8 DI DC 24V 4×M12 I/O device

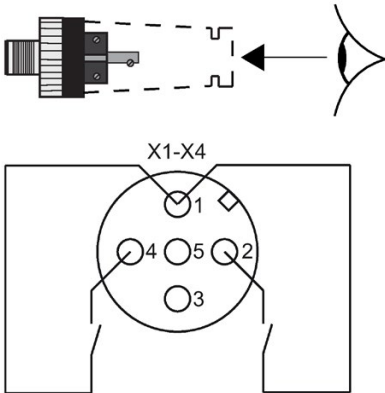
Pin	Assignment of X1 to X4	View of the cable connector (wiring side)
1	24 V sensor supply 1Us (derived from 1L+ non-switched)	
2	Input signal DI4: Connector X1 Input signal DI5: Connector X2 Input signal DI6: Connector X3 Input signal DI7: Connector X4	
3	Sensor supply ground 1M	
4	Input signal DI0: Connector X1 Input signal DI1: Connector X2 Input signal DI2: Connector X3 Input signal DI3: Connector X4	
5	Functional earth FE	

When using the Y cable, pin 2 and pin 4 are assigned to pin 4 (A) and pin 4 (B).

**I/O device 8 DI DC 24V 8xM12 (6ES7141-6BG00-0AB0)**

You will find the pin assignment for the 8 DI DC 24V 8xM12 I/O device in the table below.

Table 3- 5 Pin assignment of the M12 cable connector for the 8 DI DC 24V 8xM12 I/O device

Pin	Assignment of X1 to X8	View of the cable connector (wiring side)
1	24 V sensor supply 1Us (derived from 1L+ non-switched)	
2	Not used	
3	Sensor supply ground 1M	
4	Input signal DI0: Connector X1 Input signal DI1: Connector X2 Input signal DI2: Connector X3 Input signal DI3: Connector X4 Input signal DI4: Connector X5 Input signal DI5: Connector X6 Input signal DI6: Connector X7 Input signal DI7: Connector X8	
5	Functional earth FE	

**I/O device 16 DI DC 24V 8xM12 (6ES7141-6BH00-0BA0)**

You will find the pin assignment for the 16 DI DC 24V 8xM12 I/O device in the table below.

Table 3- 6 Pin assignment of the M12 cable connector for the 16 DI DC 24V 8xM12 I/O device

Pin	Assignment of X1 to X8	View of the cable connector (wiring side)
1	24 V sensor supply 1Us (derived from 1L+ non-switched)	
2	Input signal DI8: Connector X1 Input signal DI9: Connector X2 Input signal DI10: Connector X3 Input signal DI11: Connector X4 Input signal DI12: Connector X5 Input signal DI13: Connector X6 Input signal DI14: Connector X7 Input signal DI15: Connector X8	
3	Sensor supply ground 1M	
4	Input signal DI0: Connector X1 Input signal DI1: Connector X2 Input signal DI2: Connector X3 Input signal DI3: Connector X4 Input signal DI4: Connector X5 Input signal DI5: Connector X6 Input signal DI6: Connector X7 Input signal DI7: Connector X8	
5	Functional earth FE	

### 3.6 Pin assignment of connectors

When using the Y cable, pin 2 and pin 4 are assigned to pin 4 (A) and pin 4 (B).

---

**Note**

The M12 sockets for the supply and I/O have the same coding.

Make sure that you wire the supply and the I/O correctly.

---

### 3.6.4 Pin assignment of digital outputs

#### I/O device 8 DO DC 24V/1,3A 4xM12 (6ES7142-6BF00-0AB0)

You will find the pin assignment for the 8 DO DC 24V/1,3A 4xM12 I/O device in the table below.

Table 3-7 Pin assignment of the M12 cable connector for the 8 DO DC 24V/1,3A 4xM12 I/O device

Pin	Assignment	View of the cable connector (wiring side)
	<b>Assignment X1 and X2 (1L+ non-switched)</b>	
1	Not used	
2	Output signal DQ4: Connector X1 Output signal DQ5: Connector X2	
3	Supply ground 1M	
4	Output signal DQ0: Connector X1 Output signal DQ1: Connector X2	
5	Functional earth FE	
	<b>Assignment X3 and X4 (2L+ switched)</b>	
1	Not used	
2	Output signal DQ6: Connector X3 Output signal DQ7: Connector X4	
3	Supply ground 2M	
4	Output signal DQ2: Connector X3 Output signal DQ3: Connector X4	
5	Functional earth FE	

When using the Y cable, pin 2 and pin 4 are assigned to pin 4 (B) and pin 4 (A).

3.6 Pin assignment of connectors

**I/O device 8 DO DC 24V/0,5A 4×M12 (6ES7142-6BF50-0AB0)**

You will find the pin assignment for the 8 DO DC 24V/0,5A 4×M12 I/O device in the table below.

Table 3- 8 Pin assignment of the M12 cable connector for the 8 DO DC 24V/0,5A 4×M12 I/O device

Pin	Assignment X1 to X4 (2L+ switched)	View of the cable connector (wiring side)
1	Not used	<p>X1 - X4</p>
2	Output signal DQ4: Connector X1 Output signal DQ5: Connector X2 Output signal DQ6: Connector X3 Output signal DQ7: Connector X4	
3	Supply ground 2M	
4	Output signal DQ0: Connector X1 Output signal DQ1: Connector X2 Output signal DQ2: Connector X3 Output signal DQ3: Connector X4	
5	Not used	

When using the Y cable, pins 2 and 4 are assigned to pin 4 (B) and pin 4 (A).

**I/O device 8 DO DC 24V/1,3A 8×M12 (6ES7142-6BG00-0AB0) and 8 DO DC 24V/2,0A 8×M12 (6ES7142-6BR00-0AB0)**

The table below shows the pin assignments for I/O devices 8 DO DC 24V/1,3A 8×M12 and 8 DO DC 24V/2,0A 8×M12.

Table 3-9 Pin assignment of the M12 cable connector for I/O device 8 DO DC 24V/1,3A 8×M12 and 8 DO DC 24V/2,0A 8×M12

Pin	Assignment	View of the cable connector (wiring side)
	<b>Assignment X1 to X4 (1L+ non-switched)</b>	
1	Unassigned	
2	Not used	
3	Supply ground 1M	
4	Output signal DQ0: Connector X1 Output signal DQ1: Connector X2 Output signal DQ2: Connector X3 Output signal DQ3: Connector X4	
5	Functional earth FE	
	<b>Assignment X5 to X8 (2L+ switched)</b>	
1	Not used	
2	Not used	
3	Supply ground 2M	
4	Output signal DQ4: Connector X5 Output signal DQ5: Connector X6 Output signal DQ6: Connector X7 Output signal DQ7: Connector X8	
5	Functional earth FE	

3.6 Pin assignment of connectors

**I/O device 16 DO DC 24V/1,3A 8×M12 (6ES7142-6BH00-0AB0)**

You will find the pin assignment for the 16 DO DC 24V/1,3A 8×M12 I/O device in the table below.

Table 3- 10 Pin assignment of the M12 cable connector for the 16 DO DC 24V/1,3A 8×M12 I/O device

Pin	Assignment	View of the cable connector (wiring side)
	<b>Assignment X1 to X4 (1L+ non-switched)</b>	
1	Not used	
2	Output signal DQ <sub>8</sub> : Connector X1 Output signal DQ <sub>9</sub> : Connector X2 Output signal DQ <sub>10</sub> : Connector X3 Output signal DQ <sub>11</sub> : Connector X4	
3	Supply ground 1M	
4	Output signal DQ <sub>0</sub> : Connector X1 Output signal DQ <sub>1</sub> : Connector X2 Output signal DQ <sub>2</sub> : Connector X3 Output signal DQ <sub>3</sub> : Connector X4	
5	Functional earth FE	
	<b>Assignment X5 to X8 (2L+ switched)</b>	
1	Not used	
2	Output signal DQ <sub>12</sub> : Connector X5 Output signal DQ <sub>13</sub> : Connector X6 Output signal DQ <sub>14</sub> : Connector X7 Output signal DQ <sub>15</sub> : Connector X8	
3	Supply ground 2M	
4	Output signal DQ <sub>4</sub> : Connector X5 Output signal DQ <sub>5</sub> : Connector X6 Output signal DQ <sub>6</sub> : Connector X7 Output signal DQ <sub>7</sub> : Connector X8	
5	Functional earth FE	



When using the Y cable, pin 2 and pin 4 are assigned to pin 4 (B) and pin 4 (A).

#### Note

The M12 sockets for the supply and I/O have the same coding.

Make sure that you wire the supply and the I/O correctly.

### 3.6.5 Pin assignment for parameterizable digital input/digital output

#### I/O device 8 DIO DC 24V/1,3A 8×M12 (6ES7147-6BG00-0AB0)

You will find the pin assignment for the 8 DIO DC 24V/1,3A 8×M12 I/O device in the table below.

Table 3- 11 Pin assignment of the M12 cable connector for the 8 DIO DC 24V/1,3A 8×M12 I/O device

Pin	Assignment	View of the cable connector (wiring side)
	<b>Assignment X1 to X4 (1L+ non-switched)</b>	
1*	24 V sensor supply 1Us (derived from 1L+ non-switched)	
2	Not used	
3	Supply ground 1M	
4	Input / output signal DIQ <sub>0</sub> : Connector X1 Input/output signal DIQ <sub>1</sub> : Connector X2 Input/output signal DIQ <sub>2</sub> : Connector X3 Input/output signal DIQ <sub>3</sub> : Connector X4	
5	Functional earth FE	
	<b>Assignment X5 to X8 (2L+ switched)</b>	
1	24 V sensor supply 2Us (derived from 2L+ switched)	
2	Not used	
3	Supply ground 2M	
4	Input / output signal DIQ <sub>4</sub> : Connector X5 Input/output signal DIQ <sub>5</sub> : Connector X6 Input/output signal DIQ <sub>6</sub> : Connector X7 Input/output signal DIQ <sub>7</sub> : Connector X8	
5	Functional earth FE	

\* The sensor supply is only available when the corresponding channel is parameterized as an "Input".

### 3.6.6 Pin assignment for IO-Link Masters

#### IO-Link Master 4 IO-L + 8 DI + 4 DO DC 24V/1,3A 8×M12 (6ES7148-6JA00-0AB0)

The following tables contain the pin assignments for the IO-Link Master  
4 IO-L + 8 DI + 4 DO DC 24V/1,3A 8×M12.

Table 3- 12 Pin assignment for IO-Link Master and digital inputs

Pin	Assignment of X1 to X4	View of the cable connector (wiring side)
1	24 V sensor supply 1Us (derived from 1L+ non-switched)	
2	Input signal DI0: Connector X1 Input signal DI1: Connector X2 Input signal DI2: Connector X3 Input signal DI3: Connector X4	
3	Sensor supply ground 1M	
4	IO-Link Master Port 1 (C/Q): Connector X1 Port 2 (C/Q): Connector X2 Port 3 (C/Q): Connector X3 Port 4 (C/Q): Connector X4	
5	Not used	

Table 3- 13 Pin assignment for digital inputs

Pin	Assignment of X5 and X6	View of the cable connector (wiring side)
1	24 V sensor supply 1Us (derived from 1L+ non-switched)	
2	Input signal DI5: Connector X5 Input signal DI7: Connector X6	
3	Sensor supply ground 1M	
4	Input signal DI4: Connector X5 Input signal DI6: Connector X6	
5	Functional earth FE	

Table 3- 14 Pin assignment for digital outputs

Pin	Assignment X7 and X8 (2L+ switched)	View of the cable connector (wiring side)
1	Not used	
2	Output signal DQ <sub>1</sub> : Connector X7 Output signal DQ <sub>3</sub> : Connector X8	
3	Supply ground 2M	
4	Output signal DQ <sub>0</sub> : Connector X7 Output signal DQ <sub>2</sub> : Connector X8	
5	Functional earth FE	

### IO-Link Master 4 IO-L 4xM12 (6ES7148-6JD00-0AB0)

The following tables contain the pin assignments for the IO-Link Master 4 IO-L 4xM12.

Table 3- 15 Pin assignment for IO-Link Master

Pin	Assignment of X1 to X4	View of the cable connector (wiring side)
1	24 V sensor supply 1Us (derived from 1L+ non-switched)	
2	24 V actuator supply 2U <sub>A</sub>	
3	Sensor supply ground 1M	
4	IO-Link master Port 1 (C/Q): Connector X1 Port 2 (C/Q): Connector X2 Port 3 (C/Q): Connector X3 Port 4 (C/Q): Connector X4	
5	Actuator supply ground 2M	

\* If you use the sockets for IO-Link devices with Port Class A, do not place any signals on pins 2 and 5.

### 3.6 Pin assignment of connectors

The M12 connectors are designed as Port Class B according to IO-Link specification. Pins 2 and 5 contain an additional power supply.

A non-interacting connection of devices of various port types (class A and class B) is possible using a 3-wire connecting cable (assignment of pins 1, 3 and 4).

<b>NOTICE</b>
<b>24 V encoder supply 1Us</b>
Only use the 24 V encoder supply 1Us supplied by the IO-Link master to supply the devices.

### 3.6.7 Pin assignment for analog inputs

#### I/O device 8 AI 4 U/I + 4 RTD/TC 8×M12 (6ES7144-6KD00-0AB0)

You will find the pin assignment for the 8 AI 4 U/I + 4 RTD/TC 8×M12 I/O device in the table below.

Table 3- 16 Pin assignment for voltage and current for the 8 AI 4 U/I + 4 RTD/TC 8×M12 I/O device

Pin	Assignment of X1, X3, X5, X7	View of the cable connector (wiring side)
1	24 V sensor supply 1Us (derived from 1L+ non-switched)	<p>Voltage</p> <p>X1, X3, X5, X7</p> <p>Current</p> <p>4-wire transducer</p> <p>X1, X3, X5, X7</p> <p>2-wire transducer</p> <p>X1, X3, X5, X7</p>
2	Connector X1: Input signal M <sub>0+</sub> Connector X3: Input signal M <sub>1+</sub> Connector X5: Input signal M <sub>2+</sub> Connector X7: Input signal M <sub>3+</sub>	
3	Sensor supply ground 1M	
4	Connector X1: Input signal M <sub>0-</sub> Connector X3: Input signal M <sub>1-</sub> Connector X5: Input signal M <sub>2-</sub> Connector X7: Input signal M <sub>3-</sub>	
5	Functional earth FE	
		<p>① 4- or 5-core shielded copper cable</p> <p>② 3-, 4-, or 5-core shielded copper cable</p>

3.6 Pin assignment of connectors

Table 3- 17 Pin assignment for RTD for the 8 AI 4 U/I + 4 RTD/TC 8xM12 I/O device

Pin	Assignment of X2, X4, X6, X8 (for RTD)	View of the cable connector (wiring side)
	Connector X2: Input signal 4 Connector X4: Input signal 5 Connector X6: Input signal 6 Connector X8: Input signal 7	
<b>4-conductor</b>		X2, X4, X6, X8 <sup>①</sup> 
1	Constant current line positive $I_{Cn+}$	
2	Measurement cable positive $M_{n+}$	
3	Constant current line negative $I_{Cn-}$	
4	Measurement cable negative $M_{n-}$	
5	Functional earth FE	
<b>3-conductor</b>		X2, X4, X6, X8 <sup>②</sup> 
1	Constant current line positive $I_{Cn+}$	
2	Measurement cable positive $M_{n+}$	
3	Measurement cable negative $M_{n-}$ and constant current line negative $I_{Cn-}$	
5	Functional earth FE	
<b>2-conductor</b>		X2, X4, X6, X8 <sup>②</sup> 
1	Measurement cable positive $M_{n+}$ and constant current line positive $I_{Cn+}$	
3	Measurement cable negative $M_{n-}$ and constant current line negative $I_{Cn-}$	
5	Functional earth FE	
<sup>①</sup> 4- or 5-core shielded copper cable <sup>②</sup> 3-, 4-, or 5-core shielded copper cable		

Table 3- 18 Pin assignment for thermocouple for the 8 AI 4 U/I + 4 RTD/TC 8xM12 I/O device

Pin	Assignment X2, X4, X6, X8 (for thermocouples and $\pm 80$ mV)	View of the cable connector (wiring side)
1	Not used	
2	Connector X2: Input signal M4+ Connector X4: Input signal M5+ Connector X6: Input signal M6+ Connector X8: Input signal M7+	
3	Not used	
4	Connector X2: Input signal M4- Connector X4: Input signal M5- Connector X6: Input signal M6- Connector X8: Input signal M7-	
5	Functional earth FE	

① 3-, 4-, or 5-core shielded copper cable

**I/O device 8 AI RTD/TC 8×M12 (6ES7144-6KD50-0AB0)**

You will find the pin assignment for the 8 AI RTD/TC 8×M12 I/O device in the table below.

Table 3- 19 Pin assignment for RTD for the 8 AI RTD/TC 8×M12 I/O device

Pin	Assignment X1 to X8 (for RTD)	View of the cable connector (wiring side)
	Connector X1: Input signal 0 Connector X2: Input signal 4 Connector X3: Input signal 1 Connector X4: Input signal 6 Connector X5: Input signal 2 Connector X7: Input signal 6 Connector X7: Input signal 3 Connector X8: Input signal 7	
<b>4-conductor</b>		
1	Constant current line positive $I_{Cn+}$	
2	Measurement cable positive $M_{n+}$	
3	Constant current line negative $I_{Cn-}$	
4	Measurement cable negative $M_{n-}$	
5	Functional earth FE	
<b>3-conductor</b>		
1	Constant current line positive $I_{Cn+}$	
2	Measurement cable positive $M_{n+}$	
3	Measurement cable negative $M_{n-}$ and constant current line negative $I_{Cn-}$	
5	Functional earth FE	
<b>2-conductor</b>		
1	Measurement cable positive $M_{n+}$ and constant current line positive $I_{Cn+}$	
3	Measurement cable negative $M_{n-}$ and constant current line negative $I_{Cn-}$	
5	Functional earth FE	
① 4- or 5-core shielded copper cable ② 3-, 4-, or 5-core shielded copper cable		



Table 3- 20 Pin assignment for thermocouple for the 8 AI RTD/TC 8×M12 I/O device

Pin	Assignment of X1 to X8 (for thermocouples and ±80 mV)	View of the cable connector (wiring side)
1	Not used	
2	Connector X1: Input signal M <sub>0+</sub> Connector X2: Input signal M <sub>4+</sub> Connector X3: Input signal M <sub>1+</sub> Connector X4: Input signal M <sub>5+</sub> Connector X5: Input signal M <sub>2+</sub> Connector X6: Input signal M <sub>6+</sub> Connector X7: Input signal M <sub>3+</sub> Connector X8: Input signal M <sub>7+</sub>	
3	Not used	
4	Connector X1: Input signal M <sub>0-</sub> Connector X2: Input signal M <sub>4-</sub> Connector X3: Input signal M <sub>1-</sub> Connector X4: Input signal M <sub>5-</sub> Connector X5: Input signal M <sub>2-</sub> Connector X6: Input signal M <sub>6-</sub> Connector X7: Input signal M <sub>3-</sub> Connector X8: Input signal M <sub>7-</sub>	
5	Functional earth FE	
① 3-, 4-, or 5-core shielded copper cable		

### 3.6.8 Pin assignment M12 compensation connector for thermocouples

#### M12 compensation connectors (6ES7194-4AB00-0AA0)

You will find the pin assignment for the M12 compensation connector in the table below.

Table 3- 21 Pin assignment of the M12 compensation connector

Pin	Assignment X1	View of the M12 compensation connector
1	Measurement cable 1M+ assigned with internal Pt1000	
2	Input signal M0+	
3	Measurement cable 1M- assigned with internal Pt1000	
4	Input signal M0-	
5	Functional earth FE	
		① Cable with cores made of thermocouple materials ② Integrated resistance thermometer Pt1000 ③ M12 compensation connector

See also

Installing (Page 20)

### 3.6.9 Pin assignment for analog output

#### I/O device 4 AO U/I 4xM12 (6ES7145-6HD00-0AB0)

You will find the pin assignment for the 4 AO U/I 4xM12 I/O device in the table below.

Table 3- 22 Pin assignment for voltage and current for the 4 AO U/I 4xM12 I/O device

Pin	Assignment of X1 to X4	View of the cable connector (wiring side)
1	24 V actuator supply 1Ua (derived from 1L+ non-switched)	
2	Output signal Q0+: Connector X1 Output signal Q1+: Connector X2 Output signal Q2+: Connector X3 Output signal Q3+: Connector X4	
3	Actuator supply ground 1M	
4	Output signal Q0-: Connector X1 Output signal Q1-: Connector X2 Output signal Q2-: Connector X3 Output signal Q3-: Connector X4	
5	Functional earth FE	

① 3-, 4-, or 5-core shielded copper cable

## 3.7 Wiring the terminal block

### Tools required

You need a Phillips screwdriver of medium size to attach the terminal block and a slotted screwdriver to connect the wires.

Use the following cables to this purpose:

- Wires: Cables with core cross-section of 0.25 to 1.5 mm<sup>2</sup>
- Cable gland: Cables with external diameters of 4.5 to 10 mm

### Wiring the connectors

Prepare the wires for connection to the terminal block.

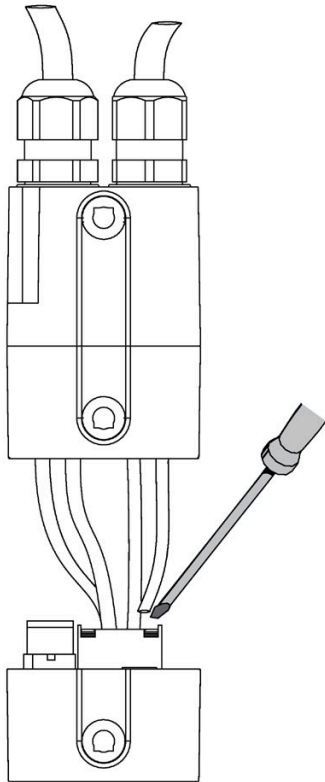

Figure 3-4 Wiring the terminal block

We'll show you an example of the separate installation of the terminal block and how to wire it to several I/O devices.

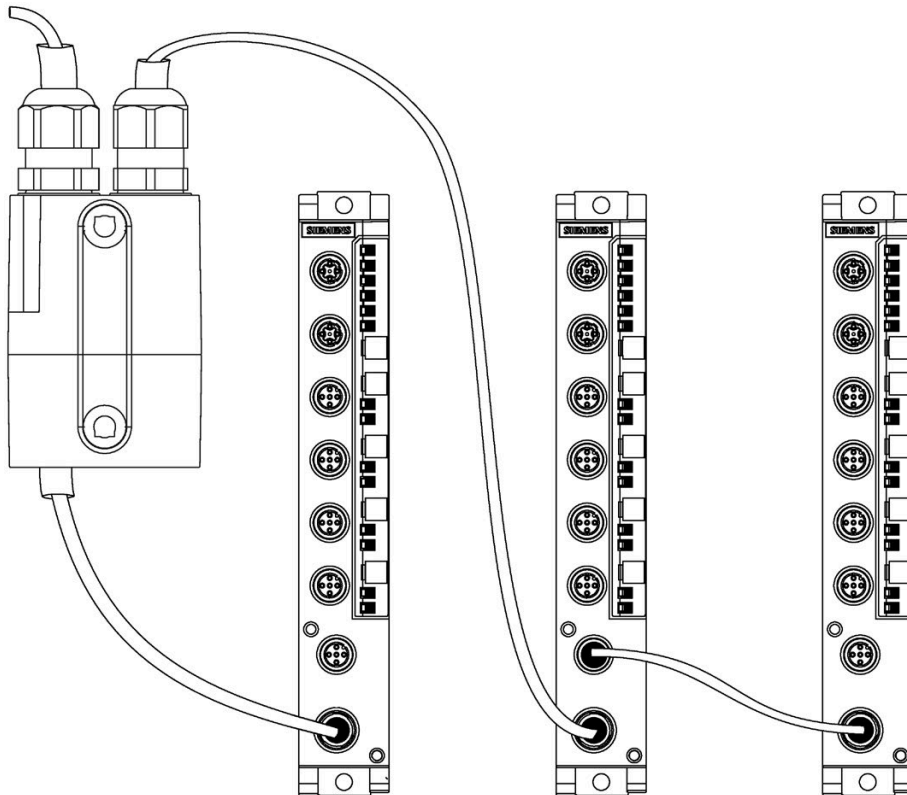

Figure 3-5 Wiring of the terminal block and of several I/O devices

3.7 Wiring the terminal block

You can tap a maximum load of 4 A from each supply voltage of the I/O device. You can loop-through the rest.

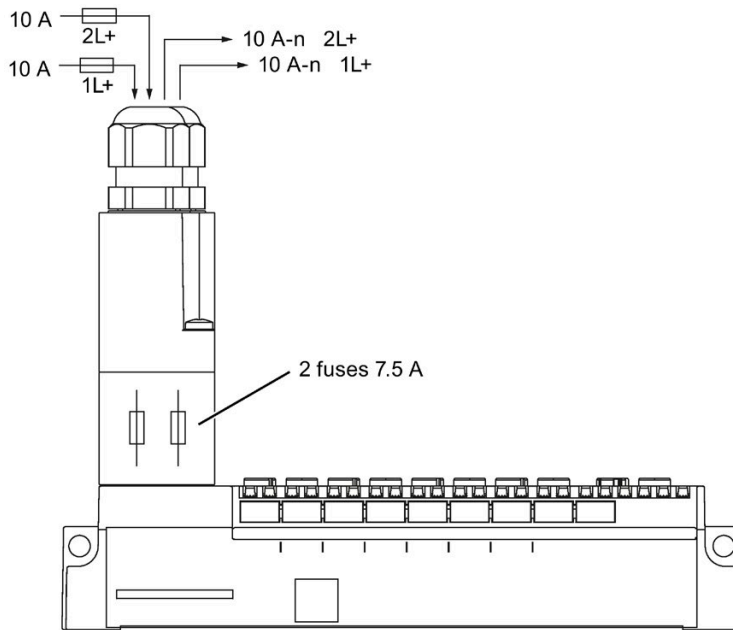

Figure 3-6 Principle of current distribution at the terminal block

Pin assignment

The tables below show the pin assignments.

Table 3- 23 Pin assignment of the insulation displacement terminal block.

Pin	Assignment	View of the insulation displacement terminal block:
1	24 V (1L+ non-switched)	
2	Ground 1M (non-switched)	
3	24 V (2L+ switched)	
4	Ground 2M (switched)	

Table 3- 24 Pin assignment of the M12 connector

Pin	Assignment	View of the cable connector
1	24 V (1L+ non-switched)	
2	Ground 2M (switched)	
3	Ground 1M (non-switched)	
4	24 V (2L+ switched)	

### Information on wiring

- If you are wiring your configuration, you must take into account the impact of cable length on the supply voltage to the ET 200eco PN (permitted tolerance).
- The maximum infeed current of the terminal block is 10 A for 1L+ non-switched and 10 A for 2L+ switched.

Do not exceed these values.

#### CAUTION

##### Adhering to the maximum infeed currents and cable cross-sections

If you do not adhere to the maximum infeed currents and the cable cross-sections required for these currents, you will risk overheating the cable insulation and contacts resulting in damage to the device.

### See also

Installing the terminal block (Page 25)

### 3.8 Wiring the voltage distributor

#### Wiring the connectors

We use an example to show the configuration of the PD DC 24V 1×7/8" 4×M12 voltage distributor with connected I/O devices.

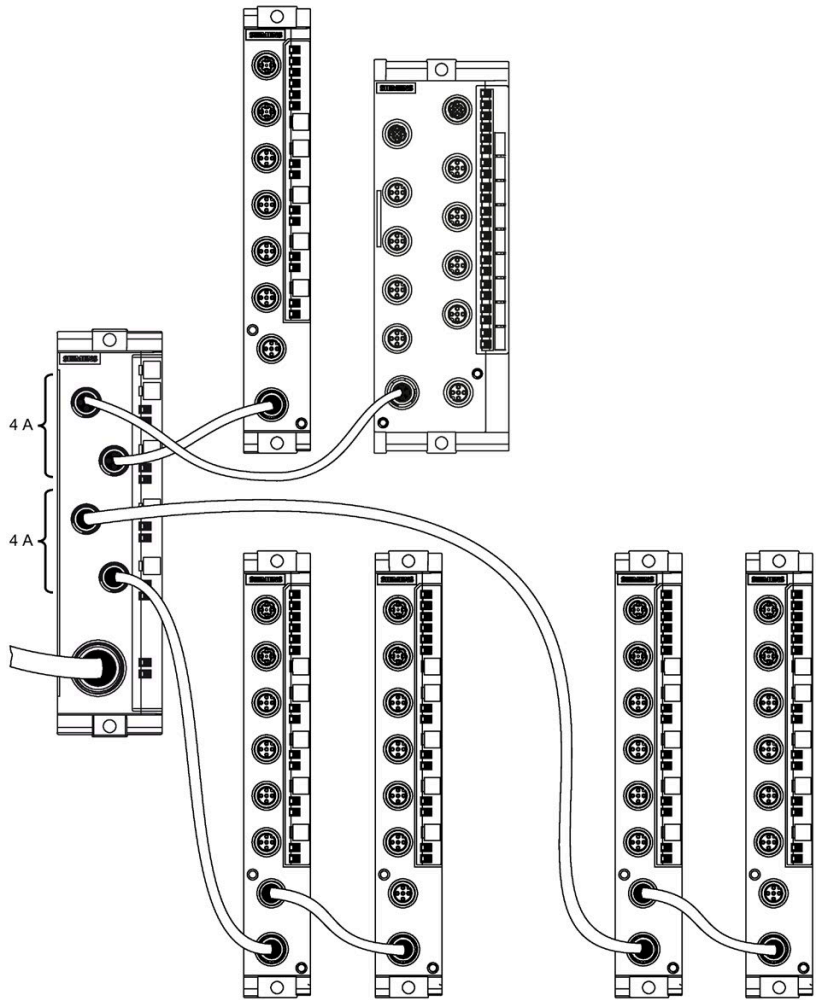

Figure 3-7 Wiring the voltage distributor



### Pin assignment

The tables below show the pin assignments.

Table 3- 25 Pin assignment of the 7/8" connector at the current input of the voltage distributor

Pin	Assignment of X05	View of the 7/8" cable connector (24 V connection)
1	Ground 2M (switched)	<p>X05</p>
2	Ground 1M (non-switched)	
3	Functional earth FE	
4	24 V (1L+ non-switched)	
5	24 V (2L+ switched)	

Table 3- 26 Pin assignment of the M12 cable connector at the current output

Pin	Assignment of X01 to X04	View of the M12 cable connector
1	24 V (1L+ non-switched)	<p>X01 - X04</p>
2	Ground 2M (switched)	
3	Ground 1M (non-switched)	
4	24 V (2L+ switched)	
5	Not used	

### Information on wiring

- If you are wiring your configuration, you must take into account the impact of cable length on the supply voltage to the ET 200eco PN (permitted tolerance).
- The maximum input current of the voltage distributor is 8 A for 1L+ non-switched and 2L+ switched.

Do not exceed these values.



#### **CAUTION**

#### **Adhering to the maximum infeed currents and cable cross-sections**

If you do not adhere to the maximum infeed currents and the cable cross-sections required for these currents, you will risk overheating the cable insulation and contacts resulting in damage to the device.

## 3.9 Looping PROFINET and the supply voltage

### Properties

The I/O device is equipped with one connector for the infeed and one socket for loop-through of the supply voltage. The feed connector and the socket for loop-through are interconnected internally.

Two sockets for PROFINET IO are available on the I/O device. One socket for the infeed and one socket for loop-through of the PROFINET IO.

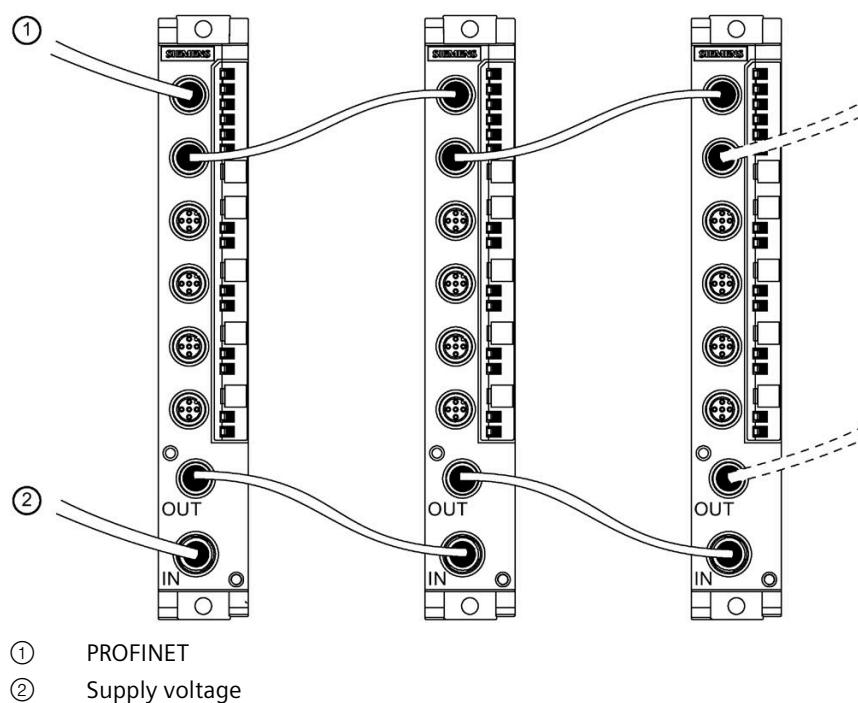

Figure 3-8 PROFINET and loop-through of supply voltage for ET 200eco PN

### Information on wiring

- Always make allowances for the influence of the cable length on the supply voltage at your ET 200eco PN (permitted tolerance) when you wire your configuration.
- The maximum infeed current of the I/O module is 4 A each for 1L+ non-switched and 2L+ switched.

These values may not be exceeded.

#### **! CAUTION**

##### **Adhering to the maximum infeed currents and cable cross-sections**

If you do not maintain the maximum infeed currents and the appropriate cable cross-sections, you will risk overheating of the cable insulation and contacts, and damage to the device.

# Configuring

## 4.1 Configuring ET 200eco PN

### Requirements

You need STEP 7 as of version V5.4, SP4 and possibly HSP.

### Introduction

ET 200eco PN is included in the hardware catalog of *HW Config* after the start of STEP 7.

### Procedure

1. Start SIMATIC Manager.
2. Create a new project.
3. Configure the ET 200eco PN with *HW Config*.
4. Double-click on the technology module at slot 1 of the ET 200eco PN in the configuration table and set the parameters.
5. Save the configuration, or download it to the IO Controller.

### Prerequisite for the GSD file

You will need a GSD file, available for download from the Internet (<http://support.automation.siemens.com/WW/view/en/19698639/133100>).

ET 200eco PN family:  
gsdml-v2.2-siemens-et200eco"date format yyyyymmdd".xml

### Configuring ET 200eco PN on PROFINET IO using STEP 7

1. Start STEP 7 and call up the **Options > Install New GSD File** menu command in *HW Config*.
2. In the next dialog box, select the GSD file to install, and confirm with "OK". Result: ET 200eco PN is displayed in the hardware catalog, PROFINET IO folder.
3. The rest of the procedure is as described in the Programming with STEP 7 (<http://support.automation.siemens.com/WW/view/en/18652056>) manual.

### See also

For further information, refer to the STEP 7 online help.

## 4.2 Configuring an IO-Link master

### 4.2.1 Configuring the IO-Link Master 6ES7148-6JA00-0AB0

#### Requirements

Configuration of the IO-Link Master takes place in two steps:

1. You need STEP 7 as of version V5.4 + SP5 + HSP188 for the IO-Link Master.
2. Configure the connected IO-Link Devices, encoders, and actuators with the Port Configurator tool (S7-PCT).

#### Configuring the IO-Link Master with HW Config

1. Start the SIMATIC Manager and configure the project as described in the STEP 7 online help.
2. Drag the IO-Link Master from the HW catalog **PROFINET IO > ET 200eco PN > IO Link > 4 IO-L + 8 DI + 4 DO DC24V/1.3A 8xM12 V6.1**.

You can freely choose the address space in the **Properties > Addresses** field for each slot of the IO-Link Master. Additional information on possible configurations is available in the chapter I/O address space (Page 265).

3. Assign the IO-Link Master parameters. You can assign the parameters separately for each functional unit:
  - The PROFINET IO parameters are accessed by double-clicking Slot 0.
  - The IO-Link parameters are accessed by double-clicking Slot 1.
  - The 8 digital input and 4 digital output parameters are accessed by double-clicking Slot 2.

#### Configuring the IO-Link Devices using "Configure IO-Link"

1. Select Slot 1 "4 IO-L" from the configuration table of the I/O device IO-Link Master.
2. Right-click and select "Configure IO-Link" in the following shortcut menu.  
Result: S7-PCT is started.
3. Now start with the parameter assignment of the IO-Link Devices, sensors, and actuators.  
You can find additional information in the S7-PCT online help.

### Configuring the IO-Link Master with GSD file

1. Install the GSD file in HW Config. The GSD file is available on the Internet (<https://support.industry.siemens.com/cs/ww/en/view/33291771>).
2. Select the IO-Link Master I/O device in the hardware catalog of HW Config.
3. You can freely choose the address space in the **Properties > Addresses** field for each slot of the IO-Link Master. In contrast to HSP configuration, the address space on Slot 1 "4 IO-L" is set permanently to 32 byte inputs and outputs. Additional information on possible configurations is available in the chapter I/O address space (Page 265).
4. Assign the IO-Link Master parameters. You can assign the parameters separately for each functional unit:
  - The PROFINET IO parameters are accessed by double-clicking Slot 0.
  - The IO-Link parameters are accessed by double-clicking Slot 1.
  - The 8 digital input and 4 digital output parameters are accessed by double-clicking Slot 2.

### Configuring the IO-Link device via S7-PCT

1. Select Slot 1 "4 IO-L" from the configuration table of the I/O device IO-Link Master.
2. Right-click and select "Start Device Tool" in the following shortcut menu.  
Result: S7-PCT is started.
3. Now start with the parameter assignment of the IO-Link Devices, sensors, and actuators.  
You can find additional information in the S7-PCT online help.

### Response of the IO-Link Master in unparameterized state and after "Resetting the IO-Link settings" via S7-PCT

- All ports of the IO-Link Master are deactivated.
- All user data are equal to 0.
- All bits of the value status are set to "invalid."
- The maintenance data 1 to 3 are deleted.

## 4.2.2 Configuring the IO-Link Master 6ES7148-6JD00-0AB0

### Introduction

The IO-Link Master 6ES7148-6JD00-0AB0 is configured and parameters are assigned in the user interface of the selected configuration software.

"**Configuring**" is understood to mean arranging, setting and networking of devices and modules.

"**Assigning parameters**" is understood to mean setting the properties of the components used. The parameters of the hardware and the settings for the data exchange are assigned in the process.

### Configuring the submodule of the IO-Link master

#### Requirements

- You have configured your automation system.
- In the device configuration of the 6ES7148-6JD00-0AB0 IO-Link Master, you have selected the IO-Link port that you want to configure.

#### Procedure

1. You configure the operating mode of the submodule. An overview of possible operating modes is available in the chapter Configuration (Page 233).
2. When you have configured the submodule and thus defined the operating mode, make the additional settings:
  - Enable the Autostart parameter (without S7-PCT)

---

#### Note

##### Changes to the port configuration

If you have assigned the parameters for the IO-Link device via Autostart (without S7-PCT), or have configured the port as digital input, digital output or disabled, you can no longer change the port configuration via S7-PCT.

---

- Enabling the diagnostics (only in IO-Link mode)
- Enable the parameter assignment for the hardware interrupts (only in IO-Link mode)

### Response after "Resetting the IO-Link settings" via S7-PCT

- Deleting the IO-Link device data in the backup memory or the IO-Link Master
- Resetting the parameters to factory state:
  - Resetting the inspection severity and the backup behavior

---

#### Note

#### Effects on the device configuration

If you have reset the IO-Link settings via S7-PCT, you have to reload the device configuration via S7-PCT.

---

## 4.3 Device names for ET 200eco PN

### Introduction

Every PROFINET IO device is assigned a unique device ID (MAC address) before it leaves the factory.

Each ET 200eco PN IO Device is addressed based on its device name during configuration and in the user program.

You will find detailed information on addressing in PROFINET IO in the the SIMATIC PROFINET system description (<http://support.automation.siemens.com/WW/view/en/19292127>) System Manual.

### Requirements

- An online PROFINET connection from the programming device to the IO Device is required for assigning the device name to the IO Device.
- The IO device is configured and an IP address assigned in *HW Config*.

### Assigning device names

1. Switch on the supply voltages for the ET 200eco PN.
2. Open the "Properties - ET 200eco PN" window in *HW Config*. Enter the device name for the IO Device and confirm your entry with "OK".
3. Select **PLC > Ethernet > Assign Device Name** in *HW Config*.
4. Click on "Assign Name" in the "Assign Device Name" window.

### Result

The device name is saved internally in the ET 200eco PN.



## Node flash test

The "Assign device name" dialog box displays all IO Devices used. Compare the MAC address of the device with the MAC address displayed and then select the correct IO Device.

The identification of IO Devices in a plant is facilitated by a node flash test. The flash test is activated as follows:

1. Select one of the displayed IO Devices from the "Assign device name" dialog box.
2. Select the flashing period.
3. Click the "Flash on" button.

The LINK LEDs flash on the selected IO Device.

## Detailed information

For additional information, refer to the *STEP 7* Online Help and the SIMATIC PROFINET system description (<http://support.automation.siemens.com/WW/view/en/19292127>) System Manual.

# 4.4 Ports of ET 200eco PN

## Introduction

The ET 200eco PN can diagnose two ports: X01 P1 R and X01 P2 R:

## Requirement

- The ports must be configured in *HW Config*.
- The port diagnostics must be enabled.

## Configuring the ports in *HW Config*

In *HW Config*, configure the two ports in the "Properties of the ET 200eco PN" dialog:

- "Addresses" tab: Diagnostic address of the respective port.
- "Topology" tab
- "Options" tab:

To enable the port diagnostics, select the following for "Connection" under "Transmission medium / Duplex": "(Monitor) automatic settings".

## See also

See the *STEP 7* online help.

## 4.5 Isochronous real-time communication

### Isochronous real-time communication

Synchronized communication protocol for cyclic exchange of IRT data between PROFINET devices. A reserved bandwidth is available within the send cycle for IRT IO data. The reserved bandwidth ensures that the IRT data are transmitted at reserved, synchronized intervals while remaining uninfluenced by another greater network load (for example, TCP/IP communication or additional realtime communication).

- "High performance" IRT option (not for 6ES7148-6JA00-0AB0 IO-Link Master):  
Topological configuration is required (STEP 7 V5.5 or higher).

---

**Note**

**When using the IO controller as a Sync-Master for IRT communication with the "high performance" IRT option, the following must be observed:**

Operate the IO controller as a Sync-Master if you configure the IRT communication with the "high performance" option.

Otherwise, IRT and RT configured IO devices may fail if the sync master fails.

---

**Note**

**Using redundant Sync-Master**

When using redundant Sync-Masters, a short-term failure of the 6ES7148-6JD00-0AB0 IO-Link Master can occur during the switching of the Sync-Master.

---

### Detailed information

For additional information, refer to the SIMATIC PROFINET system description (<http://support.automation.siemens.com/WW/view/en/19292127>) System Manual and the Migration from PROFIBUS DP to PROFINET IO (<http://support.automation.siemens.com/WW/view/en/19289930>) Programming Manual.

## 4.6 Prioritized startup

### Prioritized startup

Prioritized startup denotes PROFINET functionality for accelerating the startup of IO Devices for RT and IRT communication within a PROFINET IO system.

The function reduces the time that the correspondingly configured IO Devices require to recover the cyclic exchange of user data in the following situations:

- After power has returned
- After station recovery
- After activation of IO Devices

### Detailed information

For further information, see the SIMATIC PROFINET system description (<http://support.automation.siemens.com/WW/view/en/19292127>) System Manual and the Migration from PROFIBUS DP to PROFINET IO (<http://support.automation.siemens.com/WW/view/en/19289930>) Programming Manual.

## 4.7 Device replacement without programming device

### Device replacement without programming device

IO Devices having this function can be replaced easily:

- The device name does not have to be assigned using the programming device.

Instead of the programming device, the IO Controller now assigns the device name to the replacement IO Device. The IO Controller uses the configured topology and the correlations derived from the IO Devices. The configured target topology must agree with the actual topology.

IO Devices that have already been in operation must be reset to factory settings before being put back into operation.

### Detailed information

For further information, see the SIMATIC PROFINET system description (<http://support.automation.siemens.com/WW/view/en/19292127>) System Manual and the Migration from PROFIBUS DP to PROFINET IO (<http://support.automation.siemens.com/WW/view/en/19289930>) Programming Manual.

## 4.8 Media redundancy

### Media redundancy

Function for ensuring the network and system availability. Redundant transmission links (ring topology) ensures that an alternative communication path is made available if a transmission link fails (starting with STEP 7 V5.5) (not for 6ES7148-6JA00-0AB0 IO-Link Master up to firmware version 6.x).

For additional information, refer to the STEP 7 online help and the SIMATIC PROFINET system description (<http://support.automation.siemens.com/WW/view/en/19292127>) manual.

## 4.9 Reset to factory settings (PROFINET)

### Reset to factory settings (PROFINET)

---

**Note**

The stations of a bus segment can fail during the reset to factory settings.

---

"Reset to factory settings" is only possible if the IO Device is not exchanging data with a controller.

SNMP parameters in non-volatile memory are reset to factory settings (*STEP 7 V5.3 SP 3* and higher) in the *HW Config* dialog **PLC > Ethernet > Edit Ethernet Nodes**, "Reset" button under "Reset to factory settings".

The following retentive data are retained during the reset:

- The MAC address,

---

**Note****Deleting the device name**

The device name is deleted by means of the "Reset to factory settings" function.

---

- The I&MO data,
- The settings configured with S7-PCT,
- The outputs take up the configured substitute value behavior.

## 4.10 SNMP

### SNMP

The interface module supports the SNMP Ethernet service. MIB-2 (RFC1213) is supported. R/W objects can be edited using SNMP tools and are saved to module memory.

Following replacement with a brand new module, the R/W objects of the interface module are set to factory settings.

### See also

SIMATIC PROFINET system description  
(<http://support.automation.siemens.com/WW/view/en/19292127>)

# Commissioning

## 5.1 Commissioning ET 200eco PN

### Introduction

Your automation system is commissioned depending on the current plant configuration. The section below describes the procedure for commissioning the ET 200eco PN on an IO Controller.

### Requirements for commissioning the ET 200eco PN on the PROFINET IO

Actions	Reference
ET 200eco PN installed	Chapter Installing (Page 20)
ET 200eco PN wired	Chapter Wiring (Page 29)
The IO Device was assigned a device name	Chapter Configuring (Page 68)
ET 200eco PN configured	Chapter Configuring (Page 68)
Supply voltage for the IO Controller is switched on	IO Controller manual
IO Controller switched to RUN	IO Controller manual

### Commissioning ET 200eco PN

1. Switch on the voltage supply 1L+ non-switched for the ET 200eco PN.
2. Switch on the supply voltage(s) 2L+ switched as required.

## Startup of the ET 200eco PN on the PROFINET IO

The schematic diagram below illustrates the startup of the ET 200eco PN on the PROFINET IO:

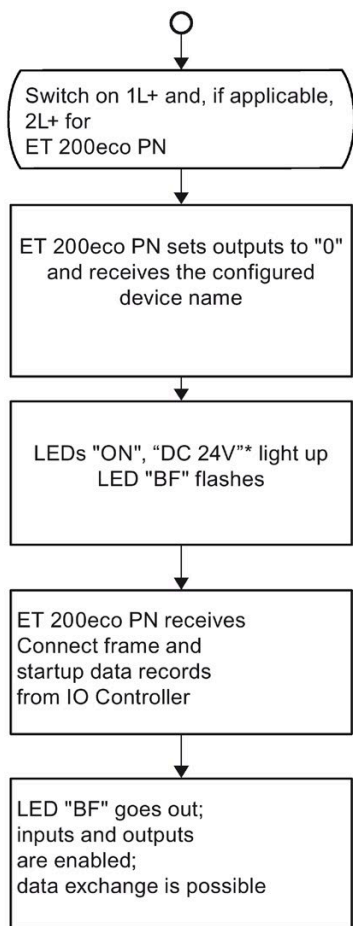

\* "DC 24V" only for digital output and if 2L+ is connected

Figure 5-1 Startup of the ET 200eco PN on the PROFINET IO

# Maintenance

## 6.1 Replacing the fuse

### Introduction

The terminal block is equipped with replaceable fuses.  
The figure below shows the fuses in the terminal block.

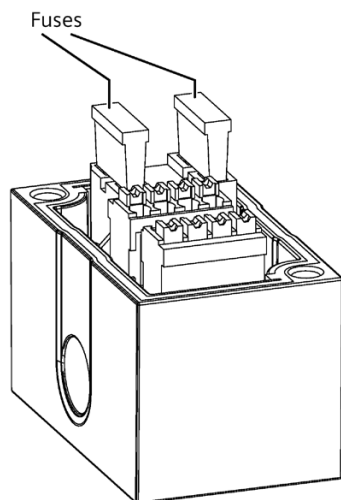

Figure 6-1 Fuses in the terminal block

### Requirements

Switch off the supply voltage before you replace any fuses. Result: CPU stop of the ET 200eco PN.

### Replacing a fuse of the terminal block

1. Remove the screws from the front panel of the terminal block using a crosstip screwdriver.
2. Remove the top section.
3. Remove the faulty fuse.
4. Press the new fuse (miniature copper flat fuse, type FK1, 7.5 A, fast-blow) into the fuse holder. The fuse is available as accessory.
5. Connect the terminal block and tighten the screws.
6. Switch on the supply voltage again.



## 6.2 Online firmware update by means of STEP 7 Manager

### Introduction

To update the firmware of the ET 200eco PN including its I/O devices, you require the \*.UPD files containing the current firmware version.

### Requirements

- An online firmware update can be performed as of STEP 7 V5.4 + SP2.
- The I/O device of the station whose firmware is to be updated must be accessible online. The network card used must be set to "TCP/IP (Auto)" in the SIMATIC Manager under **Options > Set PG/PC Interface**.
- The files containing the current firmware versions must be available in the file system of your programming device or PC. A folder must contain the files of one firmware version only.

---

#### Note

The I/O device must be reset to the factory setting before the firmware update is carried out when special port parameter assignments have been carried out.

---

### Performing a firmware update

1. Start STEP 7.
2. In the SIMATIC Manager select **PLC > Available stations**.
3. Select the I/O device.
4. Select the menu command **PLC > Update Firmware**. I/O devices without NameOfStation (NoS) are displayed with their MAC address.

As of STEP 7 V5.4 SP5, Slot 0 must also be specified for the I/O devices. In previous versions of STEP 7 this setting is specified implicitly.

With the ET 200eco PN, you can use the IO-Link Master 6ES7148-6JA00-0AB0 to perform the update of functional units:

- Slot 0: PROFINET functional unit
  - Slot 1: IO-Link functional unit
  - Slot 2: 8 DI + 4 DQ functional unit
5. In the **Update Firmware** dialog, select the path to the firmware update files (\*.UPD) using the "Browse" button.

## 6.2 Online firmware update by means of STEP 7 Manager

6. After you have selected a file, the information in the bottom boxes of the "Update Firmware" dialog box indicates the I/O device for which the file is suitable and from which firmware version.  
If the firmware is to be loaded immediately after successful installation, select the check box "Activate firmware after download". If the check box is not selected, the firmware becomes active after the next Power Off/On.
7. Click "Run". The I/O device then automatically updates the firmware.

## Result

You have updated your ET 200eco PN device online with a new firmware version.

Starting with version V6.0.0, if the ET 200eco PN I/O device was reset to the factory settings before the firmware update, the port parameter assignments are transmitted and activated again as a result of the neighborhood detection after the first connection is established between the controller and the ET 200eco PN I/O device. In previous versions, the device name had to be reassigned by selecting **PLC > Edit Ethernet Nodes ...** .

---

### Note

You can also update the firmware using *HW Config*. You can find additional information in the STEP 7 online help.

---

## 6.3 Acyclic data exchange with the IO-Link library

### Function blocks "LIOLink\_Master" and "LIOLink\_Device"

For acyclic data exchange, you can use the function blocks "LIOLink\_Master" and "LIOLink\_Device" for controllers of the S7-300, S7-400, S7-1200 and S7-1500 product lines.

The function blocks support the following tasks:

- Parameterization of an IO-Link device during operation
- Executing IO-Link port functions
- Diagnostics of IO-Link devices
- Backing up/restoring IO-Link device parameters

---

#### Note

#### Function blocks "LIOLink\_Master" and "LIOLink\_Device"

The function blocks "LIOLink\_Master" and "LIOLink\_Device" replace the functions of the previously available block "IOL\_CALL".

The "LIOLink\_Master" function block is used for all functions and accesses to the IO-Link master, and the "LIOLink\_Device" function block is used for all accesses to the IO-Link devices.

Ensure for the IO-Link master 6ES7148-6JD00-0AB0 that the "LIOLink\_Device" function block is only used for the configured submodules.

---

### Reference

For an exact description of the procedure, refer to the IO-Link System functional manual on the Internet (<https://support.industry.siemens.com/cs/ww/en/view/65949252>).

The IO-Link block library is available for download on the Internet (<https://support.industry.siemens.com/cs/ww/en/view/82981502>).

You can find additional application examples for IO-Link block library on the Internet (<https://support.industry.siemens.com/cs/ww/en/view/90529409>).

## 6.4 Exchange object

### Exchange object

With *HW Config*, the I/O devices are exchanged, for example, an 8-channel I/O device is replaced by a 16-channel I/O device. The following takes place:

With the "Exchange object" function, the device name, IP-address, etc. are taken over. The module/channel parameters are set to the "default" values.

## 6.5 Maintenance and repair

The components of the SIMATIC ET 200eco PN system are maintenance-free.

---

### **Note**

Repairs to an ET 200eco PN I/O device may only be carried out by the manufacturer.

---

## 6.6 Cleaning the I/O device

When wired, ET 200eco PN I/O devices comply with degree of protection IP65/IP67 and do not require any cleaning. If you do have to clean the I/O device, then use a dry or damp cloth. Take care to comply with the conditions of degree of protection IP65/67 when cleaning with liquids.

# Interrupt, error, and system messages

## 7.1 Interrupts of ET 200eco PN

### Introduction

The IO Device generates interrupts as a reaction to specific error events. Interrupts are evaluated depending on the IO Controller used.

### Evaluating interrupts using an IO Controller

The ET 200eco PN supports the following interrupts:

- Diagnostics interrupts
- Maintenance interrupts

In the event of an interrupt, interrupt OBs are executed automatically in the CPU of the IO Controller (refer to the System Software for S7-300/400 System and Standard Functions (<http://support.automation.siemens.com/WW/view/en/1214574>) Manual, chapter "Program design").

Information on the cause and class of the error is already available based on the OB number and start information.

You can obtain detailed information on the error event in the error OB by calling SFB 54 RALRM (read supplementary interrupt information).

### Triggering diagnostics interrupts

After having detected an incoming or outgoing event (e.g., wire break), the device triggers a diagnostic interrupt for "Group diagnostics", if enabled, and for "Diagnostics for the relevant channel".

The CPU interrupts the processing of the user program and processes the diagnostics block OB 82. The event which led to the triggering of the interrupt is entered in the start information of OB 82.

## 7.2 Maintenance interrupts

### Introduction

The PROFINET interfaces of the ET 200eco PN support the diagnostics concept and maintenance concept in PROFINET as defined in IEC 61158-6-10. The objective is early detection and elimination of potential disturbances.

### Maintenance interrupts

The following maintenance interrupts are available for the ET 200eco PN:

- Sync mismatch (no synchronization)
- Jitter out of Boundary (jitter too high)
- Frame dropped (frames are discarded)
- I/O error (with IO-Link devices)

### System alarms in *STEP 7*

The maintenance information is generated in *STEP 7* with the following system alarms:

- Maintenance required, identified by a yellow wrench icon at the relevant port.

### See also

For additional information, refer to the SIMATIC PROFINET system description (<http://support.automation.siemens.com/WW/view/en/19292127>) System Manual and the Migration from PROFIBUS DP to PROFINET IO (<http://support.automation.siemens.com/WW/view/en/19289930>) Programming Manual.

## 7.3 Diagnostics by means of LED display

### 7.3.1 Diagnostics using the LED display on the I/O devices

#### LED display

The figure below shows the position and arrangement of the LED display on the ET 200eco PN I/O devices:

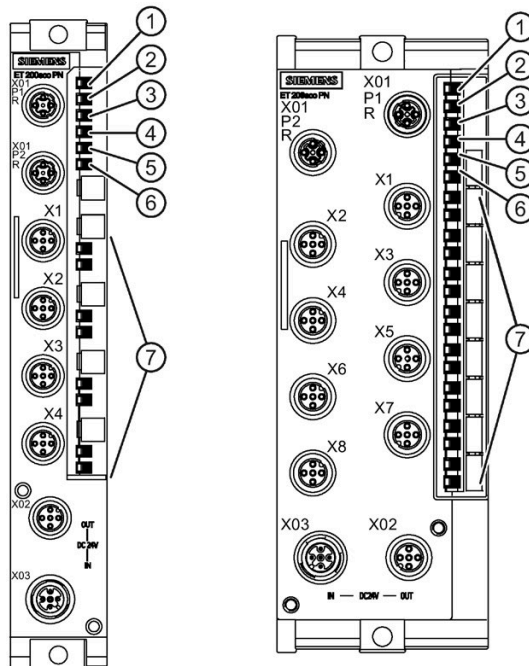

- ① SF/MT: Group fault/Maintenance (red/yellow LED)
- ② BF: Bus monitoring (red LED)
- ③ ON: Electronics/sensor/load voltage supply 1L+ non-switched (green LED)
- ④ DC 24V: Load voltage supply 2L+ switched (green LED); only for digital output device
- ⑤ P1 LK: Port1 Link (green LED)
- ⑥ P2 LK: Port2 Link (green LED)
- ⑦ Channel status, channel fault (green/red LED)

## Status and error displays SF/MT, BF, ON

Table 7- 1 Status and error displays of the ET 200eco PN

LEDs			Meaning	Remedy
SF/MT	BF	ON		
Off	Off	On	IO Device is currently exchanging data with the IO Controller without errors. The IO Device is supplied with power (electronic/sensor supply).	---
Off	Off	Off	Electronic/sensor voltage missing or too low at the I/O device.	Switch on the electronic/sensor/load supply for the IO Device.
			Hardware fault.	Replace the I/O device.
*	Flash- ing	On	Faulty or no connect message frame - no data exchange between the IO Controller and the distributed device (IO Device), although the device is physically connected to the switch. Causes: <ul style="list-style-type: none"> <li>• Incorrect device name</li> <li>• Error in configuration</li> <li>• Parameterization errors</li> </ul>	<ul style="list-style-type: none"> <li>• Check the I/O device.</li> <li>• Check the configuration and parameter settings.</li> <li>• Check the device name.</li> <li>• Check the IO Controller.</li> </ul>
*	On	On	<ul style="list-style-type: none"> <li>• The IO Device is not connected to a switch.</li> </ul>	<ul style="list-style-type: none"> <li>• Connect to the IO Controller.</li> <li>• Assign a valid device name to the I/O device.</li> <li>• Check the bus installation.</li> <li>• Check whether the M12 cable connectors are properly installed.</li> <li>• Check whether the bus cable to the IO Controller is interrupted.</li> </ul>
On (red)	*	On	Fault in peripheral circuit. Incoming diagnostics	Evaluate the diagnostics interrupt.
On (yellow)	*	*	Maintenance alarm	Analyze the maintenance alarm.
* irrelevant				

## Status display of the port LEDs

Table 7- 2 Status display of the port LEDs

LED		Meaning	Remedy
P1 LK	P2 LK		
Off	Off	No connection to the switch/IO Controller.	Check the IE cable.
On	On	Connection to switch/IO Controller.	-



### Status display DC 24V (only on I/O devices with digital outputs)

The DC 24V LED is lit in green color to indicate that you have connected the 2L+ switched load voltage supply. If the LED is not lit, check whether power is switched, or whether the fuse is okay.

## 7.3.2 Diagnostics using LED display on the IO-Link masters

### LED display IO-Link Master 4 IO-L + 8 DI + 4 DO DC 24V/1,3A 8×M12 (6ES7148-6JA00-0AB0)

The figure below shows the position and arrangement of the LED display on the IO-Link Master 4 IO-L + 8 DI + 4 DO DC 24V/1,3A 8×M12.

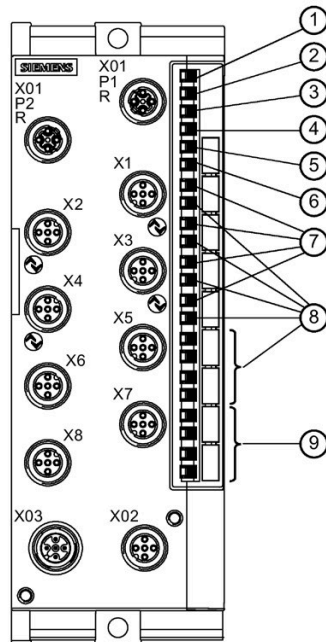

- ① SF/MT: Group fault/Maintenance (red/yellow LED)
- ② BF: Bus monitoring (red LED)
- ③ ON: Electronics/sensor/load voltage supply 1L+ non-switched (green LED)
- ④ DC 24V: Load voltage supply 2L+ switched (green LED); digital output
- ⑤ P1 LK: Port1 Link (green LED)
- ⑥ P2 LK: Port2 Link (green LED)
- ⑦ IO-L: Status display / Communications OK (green LED)
- ⑧ Input: Channel status, channel fault (green/red LED)
- ⑨ Output: Channel status, channel fault (green/red LED)

### Status display of the IO-L LEDs

The following table displays the possible status displays of the IO-L LEDs.

Table 7- 3 Status display of the IO-L LEDs

LED	Meaning
IO-L	
On	<ul style="list-style-type: none"> <li>DI/DQ operating mode: Status when input or output is activated</li> <li>IO-Link operating mode: When communication is running.</li> </ul>
flashes at 2 Hz	<ul style="list-style-type: none"> <li>during startup or continuously if no operational IO-Link device as found.</li> </ul>

### LED display IO-Link Master 4 IO-L 4xM12 (6ES7148-6JD00-0AB0)

The figure below shows the position and arrangement of the LED display on the IO-Link Master 4 IO-L 4xM12.

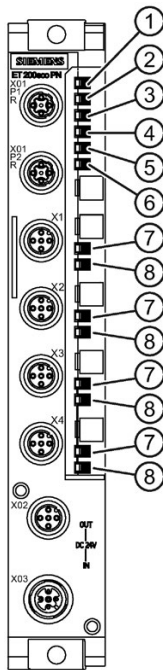

- ① SF/MT: Group fault/Maintenance (red/yellow LED)
- ② BF: Bus monitoring (red LED)
- ③ ON: Electronics/sensor/load voltage supply 1L+ non-switched (green LED)
- ④ DC 24V: Load voltage supply 2L+ switched (green LED)
- ⑤ P1 LK: Port1 Link (green LED)
- ⑥ P2 LK: Port2 Link (green LED)
- ⑦ Q 1-4: Status indicator SIO mode (Green LED)
- ⑧ IO-L 1-4: Status display IO-Link communication / channel error (green/red LED)

## LEDs Q1 to Q4

Valid for an IO-Link port that is in SIO mode.

Table 7- 4 Status displays of LEDs Q1 to Q4

LEDs	Meaning	Remedy
Q1 to Q4		
On	Input or output value is 1.	---
Off	Input or output value is 0 or port is deactivated.	---

## LEDs IO-L 1 to IO-L 4

Valid for an IO-Link port that is in IO-Link mode.

Table 7- 5 Status displays of LEDs IO-L 1 to IO-L 4

LEDs		Meaning	Remedy
SF	IO-L 1 to IO-L 4		
Off	Flashes (green)	Flashes device	Check the IO-Link device used.
On	Flashes (green)	No IO-Link communication (for example, when you have activated the port but no available IO-Link device can be found.)	Check the wiring.
Off	On (green)	IO-Link communication established, <b>no</b> pending device error.	---
On	On (red)	IO-Link communication established, pending device or channel error.	Check the IO-Link device used.
Off	Off	Port deactivated	---

## Reference

For status and error displays see section Diagnostics using the LED display on the I/O devices (Page 87).

### 7.3.3 Diagnostics using the LED display at the voltage distributor

#### LED display

The figure below shows the position and arrangement of the LED display on the voltage distributor.

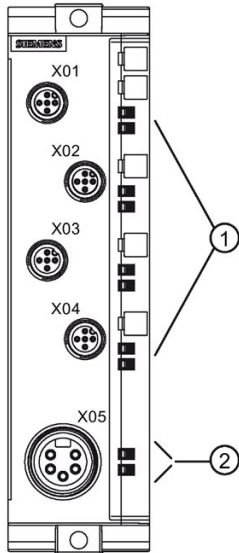

- ① Loop-through 1L/2L (green LED)
- ② Infeed voltage (green LED)

Figure 7-1 LED display at voltage distributor

Table 7- 6 Status displays on the voltage distributor

LED	Meaning
<b>1L/2L</b>	
Loop-through	
On	Voltage applied
Flashing	Overload
Off	Short-circuit
Infeed voltage	
On	Voltage applied
Off	Voltage not applied

## 7.4 Diagnostics messages of the I/O devices

### Actions after a diagnostics message

Every diagnostics message triggers the following actions:

- The SF LED (red) of the I/O device lights up.
- Several simultaneous diagnostics messages are possible.
- Diagnostics data are reported as diagnostics interrupts and can be read from data records.
- Diagnostics messages are saved to the diagnostics buffer of the I/O controller.
- OB 82 is called. If there is no OB 82, the IO Controller goes to STOP.
- Acknowledgment of the diagnostics interrupt to enable new interrupts.

## 7.5 Diagnostics with STEP 7

### 7.5.1 Reading diagnostics data

#### Options for reading the diagnostics data

Table 7-7 Reading diagnostics data in STEP 7

Automation system with IO Controller	Block or register in STEP 7	Application	See ...
SIMATIC S7	For example in <i>HW Config</i> by selecting <b>Station &gt; Open Online</b>	Device diagnostics in plain text on the STEP 7 interface (in the Quick View, Diagnostics View or Module Status windows)	"Hardware diagnostics" in the STEP 7 online help
	SFB 52 "RDREC"	Reading data records from the IO Device	SFB, see STEP 7 online help (System functions/System function blocks)
	SFB 54 "RALRM"	Receiving interrupts from the IO Device	SFB, see STEP 7 online help (System functions/System function blocks)

## 7.5.2 Channel diagnostics

### Additional information regarding the data records for PROFINET IO

For information on the structure of diagnostics data records, including programming examples, refer to the Migration from PROFIBUS DP to PROFINET IO (<http://support.automation.siemens.com/WW/view/en/19289930>) Programming Manual.

### Structure of the manufacturer-specific diagnostics data records

The structure of the diagnostics data records is differentiated based on the BlockVersion. The following block versions apply to the ET 200eco PN:

ET 200eco PN	Article number	BlockVersion
8 DI DC 24V 4×M12	6ES7141-6BF00-0AB0	W#16#0101
8 DI DC 24V 8×M12	6ES7141-6BG00-0AB0	W#16#0101
16 DI DC 24V 8×M12	6ES7141-6BH00-0AB0	W#16#0101
8 DO DC 24V/1,3A 4×M12	6ES7142-6BF00-0AB0	W#16#0101
8 DO DC 24V/0,5A 4×M12	6ES7142-6BF50-0AB0	W#16#0101
8 DO DC 24V/1,3A 8×M12	6ES7142-6BG00-0AB0	W#16#0101
8 DO DC 24V/2,0A 8×M12	6ES7142-6BR00-0AB0	W#16#0101
16 DO DC 24V/1,3A 8×M12	6ES7142-6BH00-0AB0	W#16#0101
8 DIO DC 24V/1,3A 8×M12	6ES7147-6BG00-0AB0	W#16#0101
4 IO-L + 8 DI + 4 DO DC 24V/1,3A 8×M12	6ES7148-6JA00-0AB0	W#16#0101
4 IO-L 4×M12	6ES7148-6JD00-0AB0	W#16#0101
8 AI 4 U/I + 4 RTD/TC 8×M12	6ES7144-6KD00-0AB0	W#16#0101
8 AI RTD/TC 8×M12	6ES7144-6KD50-0AB0	W#16#0101
4 AO U/I 4×M12	6ES7145-6HD00-0AB0	W#16#0101

### Manufacturer-specific diagnostics in the User Structure Identifier (USI)

- W#16#8000 channel diagnostics
- W#16#8002 extended channel diagnostics

### 7.5.3 Error classes for I/O devices

#### Error classes and remedies

The following tables show the error types for the I/O devices.

#### Error type for I/O devices, digital inputs/outputs, analog inputs/outputs

Table 7- 8 Overview Error types

Error class		Error text	Meaning	Remedy
00001 <sub>B</sub>	1 <sub>D</sub>	Short-circuit	<ul style="list-style-type: none"> <li>Short-circuit to M at the sensor supply line</li> <li>Short-circuit at the output line</li> <li>Load impedance too low</li> </ul>	<ul style="list-style-type: none"> <li>Correct the process wiring</li> <li>Check the sensor or actuator</li> </ul>
00100 <sub>B</sub>	4 <sub>D</sub>	Thermal over-load	<ul style="list-style-type: none"> <li>I/O device is overheating</li> </ul>	<ul style="list-style-type: none"> <li>Check the process wiring</li> <li>Check the ambient temperature</li> </ul>
00110 <sub>B</sub>	6 <sub>D</sub>	Wire break	<ul style="list-style-type: none"> <li>Signal line to a sensor or actuator interrupted</li> <li>Sensor or actuator failure</li> <li>Load impedance too high</li> </ul>	<ul style="list-style-type: none"> <li>Correct the process wiring</li> <li>Replace the sensor or actuator</li> <li>Use a sensor with lower impedance</li> <li>Use an actuator with lower load impedance</li> </ul>
00111 <sub>B</sub>	7 <sub>D</sub>	Violation of upper limit	<ul style="list-style-type: none"> <li>The value is above the overrange</li> </ul>	<ul style="list-style-type: none"> <li>Correct the I/O device to sensor tuning</li> <li>Modify measuring range by means of parameter assignment</li> </ul>
01000 <sub>B</sub>	8 <sub>D</sub>	Violation of lower limit	<ul style="list-style-type: none"> <li>Value is below the underrange</li> </ul>	<ul style="list-style-type: none"> <li>Correct the I/O device to sensor tuning</li> <li>Modify measuring range by means of parameter assignment</li> </ul>
01001 <sub>B</sub>	9 <sub>D</sub>	Error	<ul style="list-style-type: none"> <li>Internal I/O device error has occurred (diagnostic message on channel 0 applies to the whole I/O device).</li> </ul>	<ul style="list-style-type: none"> <li>Replacement of I/O device</li> </ul>
10000 <sub>B</sub>	16 <sub>D</sub>	Parameter assignment errors	<ul style="list-style-type: none"> <li>I/O device is incorrectly parameterized</li> </ul>	<ul style="list-style-type: none"> <li>Correct the parameter assignment</li> </ul>
10001 <sub>B</sub>	17 <sub>D</sub>	1L+ or 2L+ is missing	<ul style="list-style-type: none"> <li>Supply voltages missing or too low</li> <li>Load voltage supply missing or too low</li> </ul>	<ul style="list-style-type: none"> <li>Check the supply voltages</li> <li>Check the load voltage supply</li> <li>Correct the process wiring</li> </ul>
10101 <sub>B</sub>	21 <sub>D</sub>	Reference channel fault	<ul style="list-style-type: none"> <li>Measurement cable for compensation interrupted</li> <li>Data record DS2 incorrect</li> <li>Timeout for "Dynamic ref. Temp."</li> </ul>	<ul style="list-style-type: none"> <li>Correct the process wiring</li> <li>Check the data record DS2.</li> <li>Send DS2</li> </ul>

## Error classes for IO-Link Master (6ES7148-6JA00-0AB0), Slot 1

Table 7- 9 Overview Error types Slot 1

Error class		Error text	Meaning	IO-Link Master	IO-Link Device
00001 <sub>B</sub>	1 <sub>D</sub>	Short-circuit	Short circuit at the process cables of the IO-Link device (0x5151)		X
00010 <sub>B</sub>	2 <sub>D</sub>	Undervoltage	Supply voltage too low (0x5110 to 0x5119)		X
00100 <sub>B</sub>	4 <sub>D</sub>	Overload	Overload of the output stage of the IO-Link Devices (0x5410)		X
00101 <sub>B</sub>	5 <sub>D</sub>	Overtemperature	<ul style="list-style-type: none"> <li>Ambient temperature too high (0x4110)</li> <li>IO-Link Device too hot (0x4210)</li> <li>IO temperature exceeded (0x4310)</li> </ul>		X
00110 <sub>B</sub>	6 <sub>D</sub>	Wire break	<ul style="list-style-type: none"> <li>No IO-Link Device connected</li> <li>Incorrect IO-Link Device connected</li> <li>Signal cable to IO-Link Device interrupted</li> <li>Signal cable to IO-Link Device short-circuited</li> <li>Short-circuit of supply voltage at sensor</li> <li>IO-Link Device addressed with too short communication cycle time</li> <li>IO-Link Device cannot communicate due to another error (0xFF10)</li> </ul>	X	
00111 <sub>B</sub>	7 <sub>D</sub>	Overflow	<ul style="list-style-type: none"> <li>Process variable range exceeded (0x8C10)</li> <li>Measuring range exceeded (0x8C20)</li> </ul>		X
01000 <sub>B</sub>	8 <sub>D</sub>	Underflow	Process variable range too small (0x8C30)		X
01001 <sub>B</sub>	9 <sub>D</sub>	Error	All the IO-Link error codes not listed here will be mapped to this PROFINET IO error.		X
			Hardware error at IO-Link Master detected	X	
10000 <sub>B</sub>	16 <sub>D</sub>	Parameter assignment errors	IO-Link Master could not be parameterized	X	
			Event code of the IO-Link Device (0x6230 to 0x6340)		X
10010 <sub>B</sub>	18 <sub>D</sub>	Fuse defective	Event code of the IO-Link Device (0x5450 to 0x5459)		X
11010 <sub>B</sub>	26 <sub>D</sub>	External error	IO-Link Device cannot be set to desired mode	X	



## Errors types IO-Link Master (6ES7148-6JD00-0AB0)

### IO-Link devices diagnostics

The IO-Link master generates PROFINET channel diagnostics (CET, ECET) from the IO-Link events of an IO-Link devices according to the following mapping rules:

The IO-Link event codes of the area 0x0000 – 0x7FFF<sub>H</sub> are displayed directly in the "IO-Link Device Diagnostics - Page 1" (CET 0x9500<sub>H</sub>):

ECET<sub>H</sub> = IO-Link Event Code<sub>H</sub>

The IO-Link event codes of the area 0x8000 – 0xFFFF<sub>H</sub> are displayed directly in the "IO-Link Device Diagnostics - Page 2" (CET 0x9501<sub>H</sub>) via the following rule:

ECET<sub>H</sub> = (IO-Link Event Code<sub>H</sub> – 0x8000<sub>H</sub>)

Table 7- 10 Overview Error types IO-Link Device Diagnostics

IO-Link Event Code	Error type (CET)	Expanded error type (ECET)	Error text	Meaning
0x0000 - 0x7FFF <sub>H</sub>	0x9500 <sub>H</sub> (38144 <sub>D</sub> )	0x0000 - 0x7FFF <sub>H</sub> (0 - 32767 <sub>D</sub> )	Error / Warning	See manual of the IO-Link devices or IODD file used.
0x8000 - 0xFFFF <sub>H</sub>	0x9501 <sub>H</sub> (38134 <sub>D</sub> )	0x0000 - 0x7FFF <sub>H</sub> (0 - 32767 <sub>D</sub> )	Error / Warning	See manual of the IO-Link devices or IODD file used.

### Example of Display of IO-Link Event Codes:

An IO-Link device supports the event codes 0x4000<sub>H</sub> and 0x8CA0<sub>H</sub>.

The channel diagnostics result from the event codes:

- CET: 0x9500<sub>H</sub>, ECET: 0x4000<sub>H</sub>  
Diagnostic alarm "IO-Link Device Diagnostics - Page 1, Temperature fault - Overload", generates Event Code 0x4000<sub>H</sub> from the IO-Link.
- CET: 0x9501<sub>H</sub>, ECET: 0xCA0<sub>H</sub>  
Diagnostic alarm "IO-Link Device Diagnostics - Page 2, Ambient light interference, generates Event Code 0x8CA0<sub>H</sub> from the IO-Link.

### IO-Link Port Diagnostics

The IO-Link master generates channel diagnostics for each port. The port-specific channel diagnostics are display in the port diagnostics (CET 0x9502<sub>H</sub>).

The following table provides an overview of the possible diagnostics events and their meaning.

Table 7- 11 Overview Error types IO-Link Port Diagnostics

Error type (CET)	Expanded error type (ECET)	Error text	Meaning
0x9502H (38136D)	0x1883H (6275D)	S7-PCT configuration errors	Wrong or inconsistent parameter assignment
	0x1888H (6280D)	Module defective	Replace module
	0x7F22H (32546D)	Device not available	Communication aborted
	0x1801H (6145D)	Parameter assignment error during startup	Check the parameterization
	0x1802H (6146D)	Wrong device	Check device
	0x1803H (6147D)	Nonconformance of process data	Check submodule configuration
	0x1804H (6148D)	Short circuit at C/Q	Check port connection
	0x1805H (6149D)	IO-Link PHY overtemperature	
	0x1806H (6150D)	Short circuit at L+	Check port connection
	0x1807H (6151D)	Undervoltage at L+	Check port connection
	0x1808H (6152D)	Event overflow at device	
	0x1809H (6153D)	Backup failed	Memory outside of the area 2k
	0x180AH (6154D)	Backup inconsistent	Data storage index not available
	0x180BH (6155D)	Backup invalid	Length of the data storage index is invalid
	0x7F23H (32547D)	Backup invalid	Nonconformance in identification of data storage
	0x7F25H (32549D)	Backup invalid	Access to data storage denied
	0x180EH (6158D)	No P24 (Class B) or undervoltage	Check power supply (for example, 2L+)
	0x180FH (6159D)	Short circuit at P24 (Class B)	Check port connection
	0x6000H (24576D)	Invalid cycle time	Check cycle time
	0x6001H (24577D)	Revision error	Incomplete protocol version
	0x6002H (24578D)	Implausible device	

**See also**

For more information please refer to the STEP 7 online help and to the programming manual Migration from PROFIBUS DP to PROFINET IO (<http://support.automation.siemens.com/WW/view/en/19289930>).

## **7.5.4 STOP of the IO Controller and recovery of the IO Device**

### **Diagnostics events triggered after a STOP of the IO Controller**

Diagnostics frames received from the IO Device while the IO Controller is in STOP do not trigger the start of corresponding OBs after the restart of the IO Controller. You must explicitly read the diagnostics data from OB 100 to obtain an overview of the device state.

### **Diagnostics after recovery of the IO Device**

You must explicitly read data record E00CH by calling SFB 52 after recovery of an IO Device. This record contains all diagnostics data for the device slots assigned to an IO Controller

# General technical data

## 8.1 Standards and certifications

### Introduction

The ET 200eco PN distributed I/O system satisfies the requirements and criteria of IEC 61131-2.

---

#### Note

##### Information on the nameplate

You will find the currently valid labels and approvals on the type plate of the respective product.

---

### PROFINET IO

PROFINET IO is an open transmission protocol with real-time functionality defined in PROFINET.

### CE marking



Our products fulfill the requirements and safety objectives of the following EU Directives and comply with the harmonized European standards (EN) published for programmable logic controllers in the official journals of the European Union:

- 2014/30/EU "Electromagnetic compatibility" (EMC Guidelines)
- 2014/34/EU "Equipment and protective systems for use in hazardous areas" (Explosion protection directive)
- EU Directive 2011/65/EU "Restriction of the use of certain hazardous substances in electrical and electronic devices" (RoHS Directive)

The EU Declarations of Conformity are available to the relevant authorities at the following address:

Siemens AG  
 Digital Industries  
 Factory Automation  
 DI FA TI COS TT  
 P.O. Box 1963  
 D-92209 Amberg

These files are also available for download on the Customer Support Internet pages, under "Declaration of Conformity".

## UKCA mark



The ET 200eco PN distributed I/O system complies with the designated British standards (BS) for programmable logic controllers published in the official consolidated list of the British Government. The ET 200eco PN distributed I/O system meets the requirements and protection targets of the following regulations and related amendments:

- Electromagnetic Compatibility Regulations 2016 (EMC)
- Equipment and Protective Systems Intended for use in Potentially Explosive Atmospheres Regulations 2016 (Explosion Protection)
- The Restriction of the Use of Certain Hazardous Substances in Electrical and Electronic Equipment Regulations 2012 (RoHS).

UK declarations of conformity for the respective authorities are available from:

Siemens AG  
 Digital Industries  
 Factory Automation  
 DI FA TI COS TT  
 P.O. Box 1963  
 D-92209 Amberg

The UK declarations of conformity are also available for download from the Siemens Industry Online Support website, under the keyword "Declaration of Conformity".

## ATEX approval



According to EN 60079-15 (Electrical apparatus for potentially explosive atmospheres - Part 15: Type of protection "n"), EN 60079-0 (Electrical apparatus for potentially explosive gas atmospheres - Part 0: General Requirements) and EN 60079-31 (Equipment dust ignition protection by enclosure "t").

II 3 G Ex nA IIC T4 Gc  
 II 3 D Ex tc IIIC T90°C Dc  
 DEKRA 12ATEX0220 X

**OR**

According to EN IEC 60079-7 (Electrical apparatus for potentially explosive atmospheres - Part 7: Increased safety "e"), EN IEC 60079-0 (Electrical apparatus for potentially explosive gas atmospheres - Part 0: General Requirements) and EN 60079-31 (Electrical apparatus for potentially explosive atmospheres – Part 31: dust ignition protection by enclosure "t").

II 3 G Ex ec IIC T4 Gc  
 II 3 D Ex tc IIIC T90°C Dc  
 DEKRA 20ATEX0119 X

**Special conditions in hazardous areas:**

Install the device so that there is a minimal risk of mechanical danger.

To prevent electrostatic charging, wipe the housing surface only with a wet cloth.

Use the device only in an environment that is protected from UV light.

## 8.1 Standards and certifications

The following additional conditions apply when using the devices in an area that requires EPL Gc:

- Only use the device in an area with a degree of pollution 2 according to EN 60664-1.
- Provisions must be taken to prevent the rated voltage from being exceeded by transient disturbance voltages of more than 119 V.

### UKEX approval



According to EN IEC 60079-7 (Electrical apparatus for potentially explosive atmospheres - Part 7: Increased safety "e"), EN IEC 60079-0 (Electrical apparatus for potentially explosive gas atmospheres - Part 0: General Requirements) and EN 60079-31 (Electrical apparatus for potentially explosive atmospheres – Part 31: dust ignition protection by enclosure "t").

II 3 G Ex ec IIC T4 Gc

II 3 D Ex tc IIIC T90°C Dc

DEKRA 21UKEX0015 X

#### Special conditions in hazardous areas:

Install the device so that there is a minimal risk of mechanical danger.

To prevent electrostatic charging, wipe the housing surface only with a wet cloth.

Use the device only in an environment that is protected from UV light.

The following additional conditions apply when using the devices in an area that requires EPL Gc:

- Only use the device in an area with a degree of pollution 2 according to EN 60664-1.
- Provisions must be taken to prevent the rated voltage from being exceeded by transient disturbance voltages of more than 119 V.

**IECEx approval**

According to IEC 60079-7 (Electrical apparatus for potentially explosive atmospheres - Part 7: Increased safety "e"), IEC 60079-0 (Electrical apparatus for potentially explosive gas atmospheres - Part 0: General Requirements) and IEC 60079-31 (Electrical apparatus for potentially explosive atmospheres – Part 31: dust ignition protection by enclosure "t").

II 3 G Ex ec IIC T4 Gc  
 II 3 D Ex tc IIIC T90°C Dc  
 IECEx DEK 20.0070 X

**Special conditions in hazardous areas:**

Install the device so that there is a minimal risk of mechanical danger.

To prevent electrostatic charging, wipe the housing surface only with a wet cloth.

Use the device only in an environment that is protected from UV light.

When using the devices in an area that requires devices with EPL Gc:

- Only use the device in an area with a degree of pollution 2 according to IEC 60664-1.
- Provisions must be taken to prevent the rated voltage from being exceeded by transient disturbance voltages of more than 119 V.

**CCCEX approval**

According to GB 3836.8 (Explosive atmospheres - Part 8: Equipment protection by type of protection "n")

GB 3836.1 (Explosive atmospheres - Part 1: Equipment - General requirements)

GB 12476.1 (Electrical apparatus for use in the presence of combustible dust - Part 1: General requirements)

GB 12476.5 (Electrical apparatus for use in the presence of combustible dust - Part 5: Protection by enclosure "t")

Ex nA IIC T4 Gc

Ex tD A22 IP67 T90°C

**Special conditions in hazardous areas:**

Install the device so that there is a minimal risk of mechanical danger.

To prevent electrostatic charging, wipe the housing surface only with a wet cloth.

Use the device only in an environment that is protected from UV light.

When using the devices in an area that requires devices with EPL Gc:

- Only use the device in an area with a degree of pollution 2 according to GB/T 16935.1.
- Provisions must be taken to prevent the rated voltage from being exceeded by transient disturbance voltages of more than 119 V.

## 8.1 Standards and certifications

### RCM (C-Tick) Declaration of conformity for Australia/New Zealand



The ET 200eco PN distributed I/O system fulfills the requirements of the standard EN 61000-6-4 Generic standards - Emission standard for industrial environments.

### Korea Certificate KCC-REM-S49-ET200



Note that this device corresponds to limit class A in terms of the emission of radio frequency interference. This device can be used in all areas, except residential areas.

이 기기는 업무용(A급) 전자파 적합기기로서 판매자 또는 사용자는 이 점을 주의하시기 바라며 가정 외의 지역에서 사용하는 것을 목적으로 합니다.

### Marking for the Eurasian Customs Union



EAC (Eurasian Conformity)

Customs Union of Russia, Belarus and Kazakhstan

Declaration of conformity with the technical requirements of the Customs Union (TR CU).

### cULus approval



Underwriters Laboratories Inc. in accordance with

- UL 508 (Industrial Control Equipment)
- UL50 Enclosure Type 4X, indoor use only, watertight
- CAN/CSA C22.2 No. 142 (Process Control Equipment)

---

#### Note

#### Class 2 power supply unit

The components must be supplied with a class 2 power supply unit.

---



## Industrial applications

The ET 200eco PN distributed I/O system is designed for operation in industrial environments. It conforms to the following standards:

- Requirements for emissions EN 61000-6-4: 2007 + A1: 2011
- Requirements for immunity EN 61000-6-2: 2005

### Usage in mixed-use zone

Under certain circumstances, you can use the ET 200eco PN distributed I/O system in a mixed-use zone. A mixed-use zone is used for housing and commercial operations that do not have a significant impact on residents.

When you use the ET 200eco PN distributed I/O system in a mixed-use zone, you must ensure that the limits of the generic standard EN 61000-6-3 regarding emission of radio frequency interference are observed. Suitable measures for achieving these limits for use in a mixed-use zone include:

- Installation of the ET 200eco PN distributed I/O system in grounded control cabinets / boxes.
- Use of noise filters in the supply lines

Individual acceptance is required.

### Usage in residential area

---

#### Note

#### **ET 200eco PN distributed I/O system not intended for use in residential area**

The ET 200eco PN distributed I/O system is not intended for use in residential areas. Operation of the ET 200eco PN distributed I/O system in residential areas can have a negative influence on radio or TV reception.

---

## Marine approval

Classification authorities:

- ABS (American Bureau of Shipping)
- BV (Bureau Veritas)
- CCS (China Classification Society)
- DNVGL (Det Norske Veritas / Germanischer Lloyd)
- KR (Korean Register of Shipping)
- LRS (Lloyds Register of Shipping)
- Class NK (Nippon Kaiji Kyokai)

## See also

PI explosion protection use ecoPN  
(<https://support.industry.siemens.com/cs/ww/en/view/80484830>)

## 8.2 EMC compatibility, shipping and storage conditions

### Definition

Electromagnetic compatibility is the ability of an electrical device to function in its electromagnetic environment in a satisfactory manner without affecting this environment.

The ET 200eco PN distributed I/O device also meets the requirements of the EMC law of the European Single Market. Prerequisite is compliance of the electrical configuration of the ET 200eco PN distributed I/O device with specifications and directives.

### Pulse-shaped disturbances

The table below shows the electromagnetic compatibility of the ET 200eco PN distributed I/O device with respect to pulse-shaped disturbances.

Pulse-shaped disturbance	Test voltage	corresponds with degree of severity
Electrostatic discharge to IEC 61000-4-2	8 kV 6 kV	3 (air discharge) 3 (contact discharge)
Burst pulses (high-speed transient disturbances) according to IEC 61000-4-4.	2 kV (power supply line) 2 kV (signal line)	3 4
High-energy single pulse (surge) according to IEC 61000-4-5 *		
<ul style="list-style-type: none"> <li>• Asymmetric coupling</li> <li>• Symmetric coupling</li> </ul>	2 kV (power supply line) 2 kV (signal / data line) 1 kV (power supply line) 1 kV (signal / data line)	3
* On DC 24 V supply only with protective element		

### Sinusoidal disturbance variables

The table below shows the electromagnetic compatibility of the ET 200eco PN distributed I/O device with respect to sinusoidal disturbances.

HF radiation according to IEC 61000-4-3 Electromagnetic HF field	HF coupling according to IEC 61000-4-6
<b>Amplitude modulated</b>	
80 to 1000 MHz; 1.4 to 2 GHz	0.15 MHz to 80 MHz
10 V/m 80% AM (1 kHz)	10 V <sub>rms</sub> unmodulated
2 to 2.7 GHz	80 % AM (1 kHz)
1 V/m at 80 % AM (1 kHz)	150 Ω source impedance

### Emission of radio interference

Interference emission of electromagnetic fields in accordance with EN 61000-4-6: (measured at a distance of 10 m).

Frequency	Noise emission
30 MHz to 230 MHz	< 40 dB ( $\mu\text{V/m}$ )Q
230 MHz to 1000 MHz	<47 dB ( $\mu\text{V/m}$ ) Q

### Shipping and storage conditions

The ET 200eco PN distributed I/O device surpasses the requirements according to IEC 61131-2 for transport and storage conditions. The following information applies to modules transported or stored in their original packaging.

Type of condition	Permissible range
Free fall	$\leq 0.3$ m
Temperature	from $-40$ °C to $+70$ °C
Temperature change	20 K/h
Air pressure	From 1140 hPa to 660 hPa (corresponds with an altitude of -1000 m to 3500 m)
Relative humidity	From 5% to 95%, without condensation

## 8.3 Mechanical and climatic environmental conditions

### Climatic environmental conditions

Applicable climatic environmental conditions:

Environmental conditions	Fields of application	Remarks
Temperature	from 0 °C to 55 °C	All mounting positions
Temperature change	10 K/h	-
Relative humidity	5 % to max. 100 %	With condensation
Air pressure	From 1140 hPa to 795 hPa	Corresponds to an altitude of -1000 m to 2000 m
Pollutant concentration	ANSI/ISA-71.04 severity level G1; G2; G3	-

### Operating temperature range for the devices

The following devices can be used in different temperature ranges (indoor use only):

Designation	Article number	Fields of application			From product version
		-25 °C to 55 °C	-25 °C to 60 °C	-40 °C to 60 °C	
8 DI DC 24V 4×M12	6ES7141-6BF00-0AB0	X	X		1
		X	X	X	4
8 DI DC 24V 8×M12	6ES7141-6BG00-0AB0	X	X		1
		X	X	X	4
16 DI DC 24V 8×M12	6ES7141-6BH00-0AB0	X	X		1
		X	X	X	4
8 DO DC 24V/1,3A 4×M12	6ES7142-6BF00-0AB0	X	X		1
		X	X	X	4
8 DO DC 24V/0,5A 4×M12	6ES7142-6BF50-0AB0	X	X		1
		X	X	X	4
8 DO DC 24V/1,3A 8×M12	6ES7142-6BG00-0AB0	X	X		1
		X	X	X	4
8 DO DC 24V/2,0A 8×M12	6ES7142-6BR00-0AB0	X	X		1
		X	X	X	4
16 DO DC 24V/1,3A 8×M12	6ES7142-6BH00-0AB0	X	X		1
		X	X	X	4
8 DIO DC 24 V/1,3A 8×M12	6ES7147-6BG00-0AB0	X	X		1
		X	X	X	4
8 AI 4 U/I + 4 RTD/TC 8×M12	6ES7144-6KD00-0AB0	X	X		1
		X	X	X	4
8 AI RTD/TC 8×M12	6ES7144-6KD50-0AB0	X	X	X	1
4 AO U/I 4×M12	6ES7145-6HD00-0AB0	X	X		1
		X	X	X	4

Designation	Article number	Fields of application			From prod-
4 IO-L + 8 DI + 4 DO DC 24V/1,3A 8×M12	6ES7148-6JA00-0AB0	X	X		1
4 IO-L 4×M12	6ES7148-6JD00-0AB0	X	X	X	1
PD DC 24V 1×7/8" 4×M12	6ES7148-6CB00-0AA0	X			1
Terminal block	6ES7194-6CA00-0AA0	X			1
Mounting rail	6ES7194-6GA00-0AA0	X	X	X	1

### Mechanical environmental conditions

The table below shows the mechanical environmental conditions in the form of sinusoidal oscillation.

Devices	Frequency band	Continuous	Tested at ...
Without mounting rail	$10 \leq f \leq 58$ Hz	1.5 mm amplitude	3 mm amplitude
	$58 \leq f \leq 150$ Hz	20 g constant acceleration	40 g constant acceleration
With mounting rail	$5 \leq f \leq 8$ Hz	15 mm amplitude	-
	$8 \leq f \leq 150$ Hz	5 g constant acceleration	10 g constant acceleration

### Compatibility test, mechanical environmental conditions

The table below provides information about the type and scope of the tests of mechanical environmental conditions.

Test ...	Test standard	Terminal and I/O devices	
Vibration	Vibration test according to IEC 60068-2-6	Without mounting rail With mounting rail	Type of vibration: Frequency sweeps at a rate of change of 1 octave/minute. 10 Hz $\leq$ f $\leq$ 58 Hz, constant amplitude 3 mm 58 Hz $\leq$ f $\leq$ 150 Hz, constant acceleration 40 g 5 Hz $\leq$ f $\leq$ 12 Hz, constant amplitude 15 mm 12 Hz $\leq$ f $\leq$ 150 Hz, constant acceleration 10 g Duration of vibration: 10 frequency sweeps per axis in each of three perpendicular axes
Shock	Shock, tested in accordance with IEC 60068-2-27	Type of shock: Half-sine Shock intensity: 30 g peak value, 18 ms duration Direction of shock: 3 shocks in each +/- direction at each of the three vertically aligned axes	
Continuous shock		Type of shock: Half-sine Shock intensity: 25 g peak value, 6 ms duration Direction of shock: 1000 shocks in each +/- direction at each of the three vertically aligned axes	

8.3 Mechanical and climatic environmental conditions

**Extended environmental conditions for outdoor use**

The table below provides information about the type and scope of the tests for extended environmental conditions for outdoor use.

Test ...	Test standard	Conditions/Comments
Salt spray	IEC 60068-2-52	Severity level 1 for products used at sea or close to the ocean: 4 cycles each with: <ul style="list-style-type: none"> <li>• 2 h with 5 % NaCl at 35 °C</li> <li>• 7 days at 40 °C/93 % rel. humidity</li> </ul>
UV resistance		Chamber with glass: Sun test CPS plus Fa. Atlas Duration: 12 weeks <ul style="list-style-type: none"> <li>• Irradiance (E): 550 W/m<sup>2</sup></li> <li>• Black standard temperature (BST): 55 °C</li> </ul>
Condensation changing climate	DIN EN ISO 6270-2	Condensation climate with alternating humidity and air temperature (AHT): 84 cycles each with: <ul style="list-style-type: none"> <li>• 8 h at 40 °C +3 °C with 100% relative humidity (condensation)</li> <li>• 16 h at 18 °C to 28 °C with 100% relative humidity</li> </ul>
Thermal shock test	IEC 60068-2-14 Na	Temperature: -40 °C/+125 °C Duration: 500 cycles (500 h) Device is switched off
Hot storage	IEC 60068-2-2 Bb	Temperature: 100 °C Duration: 1 year

**Devices for operating range of extended environmental conditions in outdoor use**

The following devices can be used for extended environmental conditions in outdoor use:

Designation	Article number	From product version
8 DI DC 24V 4×M12	6ES7141-6BF00-0AB0	4
8 DI DC 24V 8×M12	6ES7141-6BG00-0AB0	4
16 DI DC 24V 8×M12	6ES7141-6BH00-0AB0	4
8 DO DC 24V/1,3A 4×M12	6ES7142-6BF00-0AB0	4
8 DO DC 24V/0,5A 4×M12	6ES7142-6BF50-0AB0	4
8 DO DC 24V/1,3A 8×M12	6ES7142-6BG00-0AB0	4
8 DO DC 24V/2,0A 8×M12	6ES7142-6BR00-0AB0	4
16 DO DC 24V/1,3A 8×M12	6ES7142-6BH00-0AB0	4
8 DIO DC 24 V/1,3A 8×M12	6ES7147-6BG00-0AB0	4
8 AI 4 U/I + 4 RTD/TC 8×M12	6ES7144-6KD00-0AB0	4
8 AI RTD/TC 8×M12	6ES5144-6KD50-0AB0	1
4 AO U/I 4×M12	6ES7145-6HD00-0AB0	4

## 8.4 Specification of dielectric tests, protection class, degree of protection, and rated voltage of ET 200eco PN

### Insulation

The insulation is designed in accordance with the requirements of EN 61131-2: 2007.

---

#### Note

In the case of modules with supply voltage 24 V DC (SELV/PELV) electrical isolation with DC 707 V (type test) are tested.

---

### Severity for voltage interruption

The distributed I/O devices of the ET 200eco PN meet the severity class PS1 for voltage interruptions (1 ms).

### Degree of protection IP65

Degree of protection according to IEC 60529:

- Protection against the ingress of dust and full touch protection
- Water projected by a nozzle against the enclosure from any direction shall have no harmful effect.

### Degree of protection IP66 and IP67

Degree of protection according to IEC 60529:

- Protection against the ingress of dust and full touch protection
- IP66: Protection against water from heavy seas or water projected in powerful jets (water must not enter the enclosure in harmful quantities)
- IP67: Protection against water when enclosure is immersed at specified pressures over a specified time period (water must not enter the enclosure in any harmful amount)









### Rated voltage for operation

The ET 200eco PN distributed I/O device operates at the following rated voltage and corresponding tolerances.

Rated voltage	Tolerance range
DC 24 V	20.4 to 28.8 V DC

## 8.5 Safety-relevant symbols for the ET 200eco PN distributed I/O system

The following table contains a declaration of the systems than can be located on the modules of the ET 200ecoPN distributed I/O system, on their packaging or on the accompanying documentation.

Symbol	Meaning
	General warning sign <b>Caution/Notice</b> You must read the product documentation. The product documentation contains information about the type of potential hazard and enables you to recognize risks and implement countermeasures.
	The assigned safety symbols apply to devices <b>with Ex approval</b> . You must read the product documentation. The product documentation contains information about the type of potential hazard and enables you to recognize risks and implement countermeasures.
	Read the information provided by the product documentation. ISO 7010 M002
	Ensure the device is only installed by an electrically skilled person. IEC 60417 No. 6182
 CABLE SPEC.	Note that connected mains lines must be designed according to the expected minimum and maximum ambient temperature.
 EMC	Note that the device must be constructed and connected in accordance with EMC regulations.
 230V MODULES	Note that a 230 V device can be exposed to electrical voltages which can be dangerous. ANSI Z535.2
 24V MODULES	Note that a device of Protection Class III must only be supplied with a protective low voltage according to the standard SELV/PELV. IEC 60417-1-5180 "Class III equipment"
 INDOOR USE ONLY INDUSTRIAL USE ONLY	If you use the ET 200ecoPN in accordance with the UL standard, take into account that the device is only approved for industrial field and only for the interior.



## 8.6 Use of the ET 200eco PN in zone 2/zone 22 hazardous areas

### Approved ET 200eco PN distributed I/O devices

You can find the EC type examination certificate with the approved ET 200eco PN I/O devices on the Internet at the following link: Type test  
(<http://support.automation.siemens.com/WW/view/de/71748103>)

### Approval

The approval is available in the section Standards and certifications (Page 100).

 <b>WARNING</b>
<b>Risk of personal injury and damage to property.</b> In hazardous areas, personal injury or damage to property may occur if you disconnect any plug connections during operation of an ET 200eco PN. In hazardous areas, always switch off the power to the ET 200eco PN when disconnecting plug connections.

### Special conditions

1. The I/O devices should be set up in such a way that the risk of mechanical danger is low.
2. The technical specifications of the I/O devices specified in the EC type examination certification must be adhered to:
  - Supply voltage of ET 200eco PN
  - Input and output currents
  - Ambient temperatures
3. M12 connectors (for PROFINET, supply voltage, encoders and actuators) must never be connected or disconnected with the power on.
4. Use the following cables with even connector outlets to wire the different M12 interfaces:
  - PROFINET: SIEMENS, order number 6XV1 870-8A or 6XV1 871-5T
  - Supply voltage: SIEMENS, order number 6XV1 801-5D
  - Encoders and actuators: SIEMENS, Y-cable, order number 6ES7194-6KA00-0XA0; PHOENIX CONTACT \*, product designation SAC-3P-M12MS

8.6 Use of the ET 200eco PN in zone 2/zone 22 hazardous areas

5. All M12 connectors must be protected against unauthorized opening, for example with safety clips. Suitable safety clips are available with PHOENIX CONTACT \*, product designation SAC-M12-EXCLIP-F or SAC-M12-EXCLIP-M.



6. All unoccupied M12 circular sockets should be closed using sealing caps in such a way that the caps cannot be loosened by hand (torque: 0.6 Nm). Suitable sealing caps are available from: Binder GmbH + Co. \*\*, item no. 08 2769 000 000.



\* PHOENIX CONTACT GmbH & Co. KG, Flachsmarktstr. 8, D-32825 D-Blomberg,  
<http://www.phoenixcontact.com> (<http://www.phoenixcontact.com>)

\*\* Fa. Binder GmbH & Co., Elektrische Bauelemente KG, Rötelstr. 7, D-74148 Neckarlsulm,  
<http://www.binder-connector.com> (<http://www.binder-connector.com>)

## I/O device digital inputs/digital outputs

### 9.1 I/O device digital inputs

#### 9.1.1 I/O device 8 DI DC 24 V 4xM12

##### Article number

6ES7141-6BF00-0AB0

##### Properties

The 8 DI DC 24V 4xM12 I/O device has the following properties:

- 8 digital inputs
- Dimensions 30 x 200 mm, dual assignment of the sockets
- Rated input voltage DC 24 V
- Suitable for switches and proximity switches
- Diagnostics
  - "Missing 1L+" for the I/O device
  - "Short-circuit to M at sensor supply", per channel group
  - "Wire break", per channel
- Prioritized startup
- Media redundancy

9.1 I/O device digital inputs

**Pin assignment of the DI sockets**

The table below shows the pin assignment of the four sockets for connecting the digital inputs

Table 9- 1 Pin assignment of the digital input sockets X1 to X4

Pin	Assignment				View of socket (front view)
	Socket X1	Socket X2	Socket X3	Socket X4	
1	24 V sensor supply 1Us(derived from 1L+ non-switched)				
2	Input signal				
	DI4	DI5	DI6	DI7	
3	Sensor supply ground 1M				
4	Input signal				
	DI0	DI1	DI2	DI3	
5	Functional earth FE				

**Block diagram**

The block diagram below shows the 8 DI DC 24V 4xM12 I/O device.

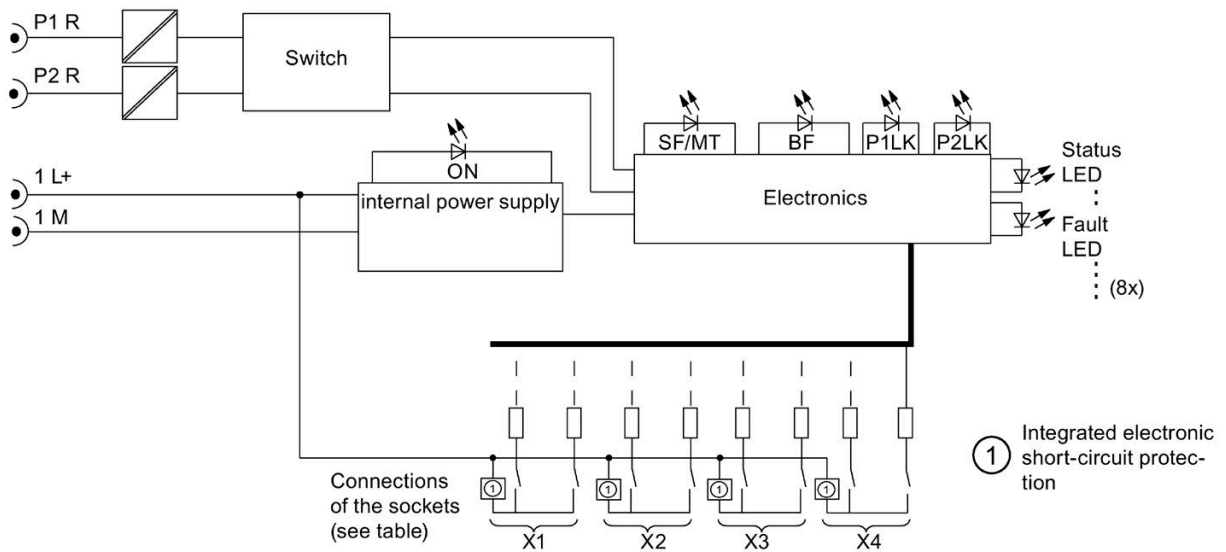

Figure 9-1 Block diagram of the 8 DI DC 24V 4xM12 I/O device

## Technical data of the 8 DI DC 24V 4xM12 I/O device

Technical data	
<b>Dimensions and weight</b>	
Dimensions W x H x D (mm)	30 x 200 x 49
Weight	Approx. 550 g
<b>Module-specific data</b>	
Transmission rate	100 Mbps full duplex
Transmission mode	100BASE-TX
Autonegotiation	Yes
Bus protocol	PROFINET IO <ul style="list-style-type: none"> <li>• IRT with the option "high flexibility"</li> <li>• IRT with the option "high performance"</li> </ul>
Supported Ethernet services	PROFINET IO (Device) <ul style="list-style-type: none"> <li>• ping</li> <li>• arp</li> <li>• LLDP</li> <li>• Network diagnostics (SNMP)</li> <li>• DCP</li> <li>• Prioritized startup</li> <li>• Media redundancy</li> </ul>
<b>PROFINET interface</b>	
• Connection socket	2 x M12 d-coded
• Switch function	Yes, internal
• Auto-crossover	Yes, if autonegotiation is enabled
Manufacturer ID (Vendor ID)	002A <sub>H</sub>
Device ID (DeviceID)	0306 <sub>H</sub>
<b>Voltages and currents</b>	
Supply voltage 1L+	DC 24 V
• Reverse polarity protection	Yes; against destruction
• Infeed current 1L+	Max. 4 A
Supply voltage 2L+	DC 24 V
• Infeed current 2L+	Max. 4 A
<b>Current consumption</b>	
From supply voltage (1L+)	Typ. 100 mA
Power loss of the device	Typ. 5.5 W
<b>Digital inputs</b>	
Number of inputs	8
Number of inputs that can be controlled simultaneously	8, in all mounting positions

<b>Technical data</b>	
<b>Insulation</b>	
Insulation test voltage	
• Ethernet interface	1500 V <sub>rms</sub> (IEEE802.3, Type Test)
• All other circuit elements	707 V DC (type test)
<b>Electrical isolation</b>	
• Between 1L+ and 2L+	Yes
• Between 1L+, channels and all other circuit elements	No
• Between channels	No
• Between Ethernet and all other circuit elements	Yes
<b>Status, interrupts, diagnostics</b>	
Interrupts	Yes
Diagnostics function	Yes
• Group error/maintenance	Red/yellow "SF/MT" LED
• Bus monitoring PROFINET IO	Red "BF" LED
• Monitoring of supply voltage 1L+	Green "ON" LED
• Existing connection to network	Green "P1 LK" and "P2 LK" LED; LED for PROFINET IO infeed and loop-through
• Digital input	Green LED
• Fault at digital input	Red LED
• Diagnostic information can be read	Yes
Monitoring for	
• Short-circuit	Yes, per channel group
• Wire break	Input current < 0.3 mA, per channel
• Missing sensor supply	Yes
<b>Sensor supply</b>	
Number of sensor supplies	4
Load current	100 mA per output
Short-circuit protection	Yes, electronic
<b>Sensor selection data</b>	
Cable length, shielded	Max. 30 m
Cable length, unshielded	Max. 30 m
Input voltage	
• Nominal value	DC 24 V
• For signal "1"	11 to 30 V
• For signal "0"	-3 to +5 V
Input current	
• At signal "1"	Typ. 7 mA

9.1 I/O device digital inputs

Technical data	
Input delay	
• At "0" to "1"	Typ. 3 ms
• At "1" to "0"	Typ. 3 ms
Input characteristic	According to IEC 61131, Type 3
Connection of 2-wire proximity switches	Supported
• Permitted quiescent current	Max. 1.5 mA

9.1.2 I/O device 8 DI DC 24 V 8xM12

Article number

6ES7141-6BG00-0AB0

Properties

The 8 DI DC 24V 8xM12 I/O device has the following properties:

- 8 digital inputs
- Dimensions 60 x 175 mm, single assignment of the sockets
- Rated input voltage DC 24 V
- Suitable for switches and proximity switches
- Diagnostics
  - "Missing 1L+" for the I/O device
  - "Short-circuit to M at sensor supply" per channel
  - "Wire break", per channel
- Prioritized startup
- Media redundancy



## Pin assignment of the sockets

The table below shows the pin assignment of the eight sockets for connecting the digital inputs.

Table 9- 2 Pin assignment of sockets X1 to X8 for digital inputs

Pin	Assignment								View of socket (front view)
	Socket X1	Socket X2	Socket X3	Socket X4	Socket X5	Socket X6	Socket X7	Socket X8	
1	24 V sensor supply 1Us(derived from 1L+ non-switched)								
2	Not used								
3	Sensor supply ground 1M								
4	Input signal								
	DI <sub>0</sub>	DI <sub>1</sub>	DI <sub>2</sub>	DI <sub>3</sub>	DI <sub>4</sub>	DI <sub>5</sub>	DI <sub>6</sub>	DI <sub>7</sub>	
5	Functional earth FE								

### Block diagram

The block diagram below shows the 8 DI DC 24V 8xM12 I/O device.

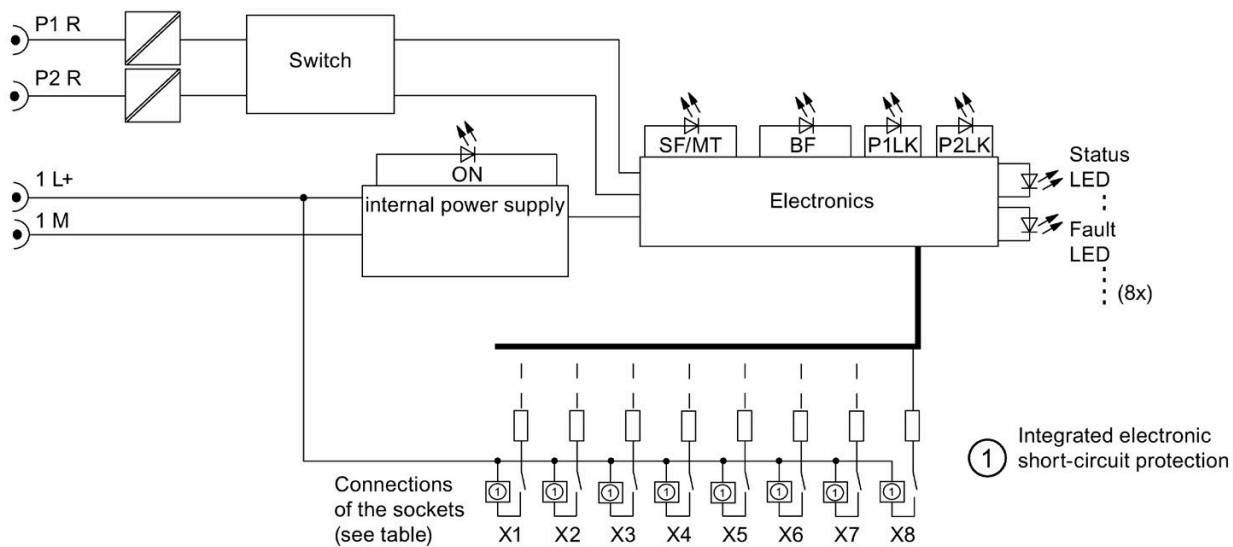

Figure 9-2 Block diagram of the 8 DI DC 24V 8xM12 I/O device

## Technical data of the 8 DI DC 24V 8xM12 I/O device

<b>Technical data</b>	
<b>Dimensions and weight</b>	
Dimensions W x H x D (mm)	60 x 175 x 49
Weight	Approx. 910 g
<b>Module-specific data</b>	
Transmission rate	100 Mbps full duplex
Transmission mode	100BASE-TX
Autonegotiation	Yes
Bus protocol	PROFINET IO <ul style="list-style-type: none"> <li>• IRT with the option "high flexibility"</li> <li>• IRT with the option "high performance"</li> </ul>
Supported Ethernet services	PROFINET IO (Device) <ul style="list-style-type: none"> <li>• ping</li> <li>• arp</li> <li>• LLDP</li> <li>• Network diagnostics (SNMP)</li> <li>• DCP</li> <li>• Prioritized startup</li> <li>• Media redundancy</li> </ul>
<b>PROFINET interface</b>	
• Connection socket	2 x M12 d-coded
• Switch function	Yes, internal
• Auto-crossover	Yes, if autonegotiation is enabled
Manufacturer ID (Vendor ID)	002A <sub>H</sub>
Device ID (DeviceID)	0306 <sub>H</sub>
<b>Voltages and currents</b>	
Supply voltage 1L+	DC 24 V
• Reverse polarity protection	Yes; against destruction
• Infeed current 1L+	Max. 4 A
Supply voltage 2L+	DC 24 V
• Infeed current 2L+	Max. 4 A
<b>Current consumption</b>	
From supply voltage (1L+)	Typ. 100 mA
From supply voltage (2L+)	0 mA
Power loss of the device	4.5 W, typical
<b>Digital inputs</b>	
Number of inputs	8
Number of inputs that can be controlled simultaneously	8, in all mounting positions
<b>Insulation</b>	
Insulation test voltage	

<b>Technical data</b>	
• Ethernet interface	1500 V <sub>rms</sub> (IEEE802.3, Type Test)
• All other circuit elements	707 V DC (type test)
<b>Electrical isolation</b>	
• Between 1L+ and 2L+	Yes
• Between 1L+, channels and all other circuit elements	No
• Between channels	No
• Between Ethernet and all other circuit elements	Yes
<b>Status, interrupts, diagnostics</b>	
Interrupts	Yes
Diagnostics function	Yes
• Group error/maintenance	Red/yellow "SF/MT" LED
• Bus monitoring PROFINET IO	Red "BF" LED
• Monitoring of supply voltage 1L+	Green "ON" LED
• Existing connection to network	Green "P1 LK" and "P2 LK" LED; LED for PROFINET IO infeed and loop-through
• Digital input	Green LED
• Fault at digital input	Red LED
• Diagnostic information can be read	Yes
<b>Monitoring for</b>	
• Short-circuit	Yes, per channel
• Wire break	Input current < 0.3 mA, per channel
• Missing sensor supply	Yes
<b>Sensor supply</b>	
Number of sensor supplies	8
Load current	100 mA per output
Short-circuit protection	Yes, electronic
<b>Sensor selection data</b>	
Cable length, shielded	Max. 30 m
Cable length, unshielded	Max. 30 m
<b>Input voltage</b>	
• Nominal value	DC 24 V
• For signal "1"	11 to 30 V
• For signal "0"	-3 to +5 V
<b>Input current</b>	
• At signal "1"	Typ. 7 mA
<b>Input delay</b>	

Technical data	
• At "0" to "1"	Typ. 3 ms
• At "1" to "0"	Typ. 3 ms
Input characteristic	According to IEC 61131, Type 3
Connection of 2-wire proximity switches	Supported
• Permitted quiescent current	Max. 1.5 mA

### 9.1.3 I/O device 16 DI DC 24 V 8xM12

#### Article number

6ES7141-6BH00-0AB0

#### Properties

The 16 DI DC 24V 8xM12 I/O device has the following properties:

- 16 digital inputs
- Dimensions 60 x 175 mm, dual assignment of the sockets
- Rated input voltage DC 24 V
- Suitable for switches and proximity switches
- Diagnostics
  - "Missing 1L+" for the I/O device
  - "Short-circuit to M at sensor supply", per channel group
  - "Wire break", per channel
- Prioritized startup
- Media redundancy

9.1 I/O device digital inputs

**Pin assignment of the sockets**

The table below shows the pin assignment of the eight sockets for connecting the digital inputs.

Table 9- 3 Pin assignment of sockets X1 to X8 for digital inputs

Pin	Assignment								View of socket (front view)
	Socket X1	Socket X2	Socket X3	Socket X4	Socket X5	Socket X6	Socket X7	Socket X8	
1	24 V sensor supply 1Us(derived from 1L+ non-switched)								
2	Input signal								
	DI8	DI9	DI10	DI11	DI12	DI13	DI14	DI15	
3	Sensor supply ground 1M								
4	Input signal								
	DI0	DI1	DI2	DI3	DI4	DI5	DI6	DI7	
5	Functional earth FE								

**Block diagram**

The block diagram below shows the 16 DI DC 24V 8×M12 I/O device.

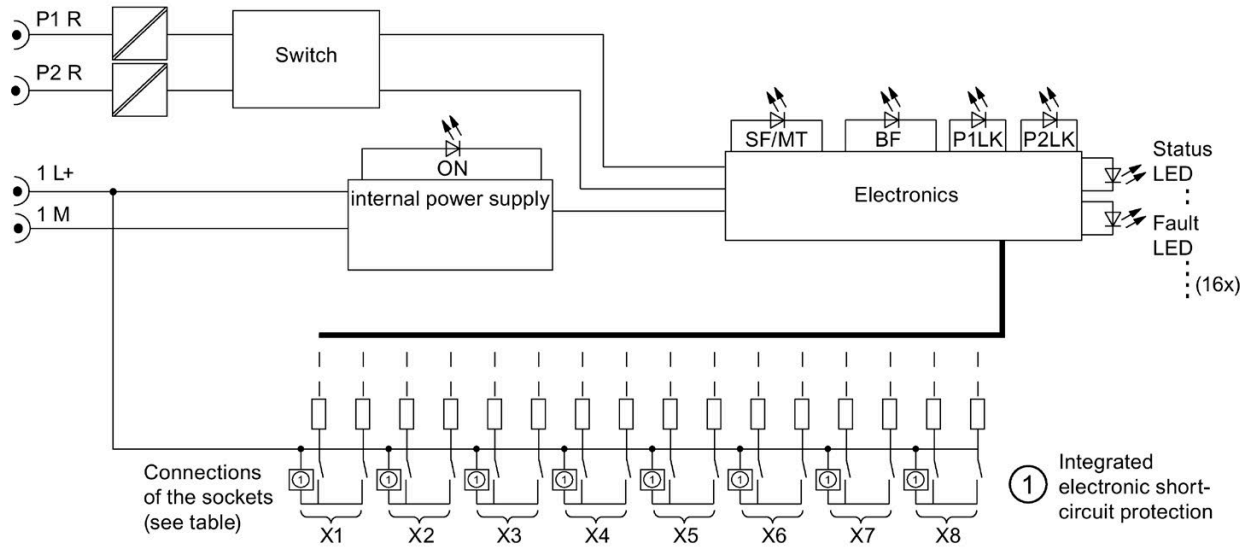

Figure 9-3 Block diagram of the 16 DI DC 24V 8×M12 I/O device

## Technical data of the 16 DI DC 24V 8xM12 I/O device

Technical data	
<b>Dimensions and weight</b>	
Dimensions W x H x D (mm)	60 x 175 x 49
Weight	Approx. 910 g
<b>Module-specific data</b>	
Transmission rate	100 Mbps full duplex
Transmission mode	100BASE-TX
Autonegotiation	Yes
Bus protocol	PROFINET IO <ul style="list-style-type: none"> <li>• IRT with the option "high flexibility"</li> <li>• IRT with the option "high performance"</li> </ul>
Supported Ethernet services	PROFINET IO (Device) <ul style="list-style-type: none"> <li>• ping</li> <li>• arp</li> <li>• LLDP</li> <li>• Network diagnostics (SNMP)</li> <li>• DCP</li> <li>• Prioritized startup</li> <li>• Media redundancy</li> </ul>
<b>PROFINET interface</b>	
• Connection socket	2 x M12 d-coded
• Switch function	Yes, internal
• Auto-crossover	Yes, if autonegotiation is enabled
Manufacturer ID (Vendor ID)	002A <sub>H</sub>
Device ID (DeviceID)	0306 <sub>H</sub>
<b>Voltages and currents</b>	
Supply voltage 1L+	DC 24 V
• Reverse polarity protection	Yes; against destruction
• Infeed current 1L+	Max. 4 A
Supply voltage 2L+	DC 24 V
• Infeed current 2L+	Max. 4 A
<b>Current consumption</b>	
From supply voltage (1L+)	Typ. 100 mA
From supply voltage (2L+)	0 mA
Power loss of the device	6.5 W, typical
<b>Digital inputs</b>	
Number of inputs	16
Number of inputs that can be controlled simultaneously	16 at all mounting positions



<b>Technical data</b>	
<b>Insulation</b>	
Insulation test voltage	
• Ethernet interface	1500 V <sub>rms</sub> (IEEE802.3, Type Test)
• All other circuit elements	707 V DC (type test)
<b>Electrical isolation</b>	
• Between 1L+ and 2L+	Yes
• Between 1L+, channels and all other circuit elements	No
• Between channels	No
• Between Ethernet and all other circuit elements	Yes
<b>Status, interrupts, diagnostics</b>	
Interrupts	Yes
Diagnostics function	Yes
• Group error/maintenance	Red/yellow "SF/MT" LED
• Bus monitoring PROFINET IO	Red "BF" LED
• Monitoring of supply voltage 1L+	Green "ON" LED
• Existing connection to network	Green "P1 LK" and "P2 LK" LED; LED for PROFINET IO infeed and loop-through
• Digital input	Green LED
• Fault at digital input	Red LED
• Diagnostic information can be read	Yes
Monitoring for	
• Short-circuit	Yes, per channel group
• Wire break	Input current < 0.3 mA, per channel
• Missing sensor supply	Yes
<b>Sensor supply</b>	
Number of sensor supplies	8
Load current	100 mA per output
Short-circuit protection	Yes, electronic
<b>Sensor selection data</b>	
Cable length, shielded	Max. 30 m
Cable length, unshielded	Max. 30 m
Input voltage	
• Nominal value	DC 24 V
• For signal "1"	11 to 30 V
• For signal "0"	-3 to +5 V
Input current	
• At signal "1"	Typ. 7 mA

## 9.1 I/O device digital inputs

Technical data	
Input delay	
• At "0" to "1"	Typ. 3 ms
• At "1" to "0"	Typ. 3 ms
Input characteristic	According to IEC 61131, Type 3
Connection of 2-wire proximity switches	Supported
• Permitted quiescent current	Max. 1.5 mA

## 9.1.4 Parameter overview digital inputs

## Parameters for 8 DI DC 24V 4×M12 (6ES7141-6BF00-0AB0) and for 8 DI DC 24V 8×M12 (6ES7141-6BG00-0AB0)

Parameter	Range of values	Default setting	Range of effectiveness
Group diagnostics	<ul style="list-style-type: none"> <li>• Disable</li> <li>• Enable</li> </ul>	Disable	Device
Diagnostics: Missing 1L+	<ul style="list-style-type: none"> <li>• Disable</li> <li>• Enable</li> </ul>	Disable	Device
Diagnostics: Wire break at inputs 0 to 7 (channels 0 to 7)	<ul style="list-style-type: none"> <li>• Disable</li> <li>• Enable</li> </ul>	Disable	Channel
Diagnostics: Short-circuit to M, inputs 0,4/1,5/2,6/3,7 (channels 0,4/1,5/2,6/3,7)	<ul style="list-style-type: none"> <li>• Disable</li> <li>• Enable</li> </ul>	Disable	Channel group

## Parameters for 16 DI DC 24V 8×M12 (6ES7141-6BH00-0AB0)

Parameter	Range of values	Default setting	Range of effectiveness
Group diagnostics	<ul style="list-style-type: none"> <li>• Disable</li> <li>• Enable</li> </ul>	Disable	Device
Diagnostics: Missing 1L+	<ul style="list-style-type: none"> <li>• Disable</li> <li>• Enable</li> </ul>	Disable	Device
Diagnostics: Wire break at inputs 0 to 15 (channels 0 to 15)	<ul style="list-style-type: none"> <li>• Disable</li> <li>• Enable</li> </ul>	Disable	Channel
Diagnostics: Short-circuit to M, inputs 0,8/1,9/2,10/3,11/4,12/5,13/6,14/7,15 (channels 0,8/1,9/2,10/3,11/4,12/5,13/6,14/7,15)	<ul style="list-style-type: none"> <li>• Disable</li> <li>• Enable</li> </ul>	Disable	Channel group

## 9.2 I/O device digital outputs

### 9.2.1 I/O device 8 DO DC 24 V/1.3A 4xM12

#### Article number

6ES7142-6BF00-0AB0

#### Properties

The 8 DO DC 24V/1,3A 4xM12 I/O device has the following properties:

- 8 digital outputs
- Dimensions 30 x 200 mm and duplicate assignment of the sockets
- Output current: 1.3 A per output
- Rated load voltage DC 24 V
- Suitable for solenoid valves, DC contactors, and indicator lights
- Diagnostics
  - "Missing 1L+ or 2L+" for the I/O device
  - "Wire break at outputs" per channel
  - "Short-circuit to M at outputs" per channel
- Parameterizable response to CPU/Master STOP
- Prioritized startup
- Media redundancy

#### Pin assignment of the sockets for digital outputs

The table below shows the pin assignment of the four sockets for connecting digital outputs.

Table 9- 4 Pin assignment of sockets X1 to X4 for digital outputs

Pin	Assignment				View of socket (front view)
	Socket X1	Socket X2	Socket X3	Socket X4	
	24 V (1L+ non-switched)		24 V (2L+ switched)		
1	Not used				
2	Output signal				
	DQ <sub>4</sub>	DQ <sub>5</sub>	DQ <sub>6</sub>	DQ <sub>7</sub>	
3	Ground 1M		Ground 2M		
4	Output signal				
	DQ <sub>0</sub>	DQ <sub>1</sub>	DQ <sub>2</sub>	DQ <sub>3</sub>	
5	Functional earth FE				

**Block diagram**

The block diagram below shows the 8 DO DC 24V/1,3A 4xM12 I/O device.

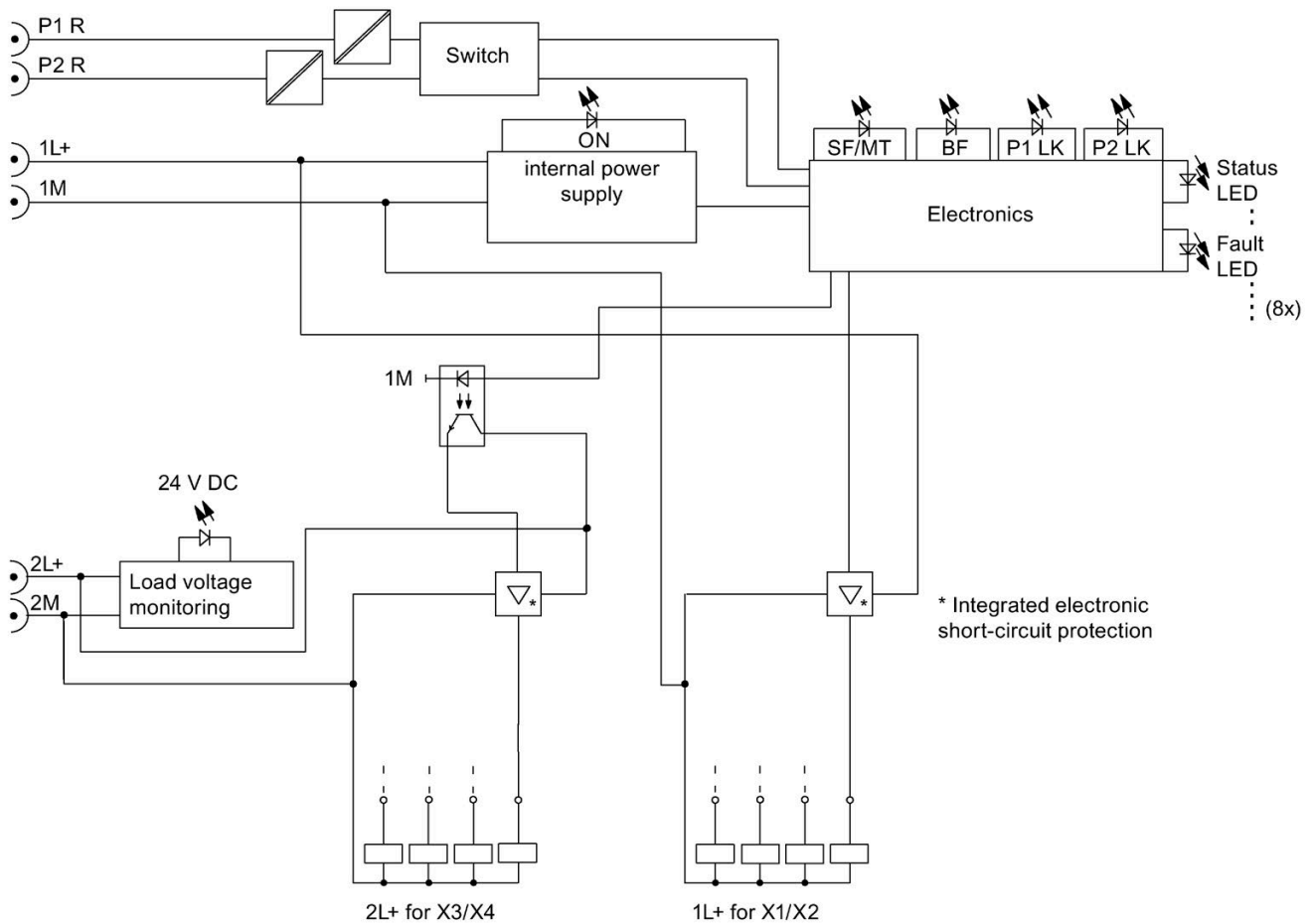

Figure 9-4 Block diagram of the 8 DO DC 24V/1,3A 4xM12 I/O device

## Technical specifications of the 8 DO DC 24V/1,3A 4×M12 I/O device

Technical specifications	
<b>Dimensions and weight</b>	
Dimensions W x H x D (mm)	30 x 200 x 49
Weight	Approx. 550 g
<b>Module-specific data</b>	
Transmission rate	100 Mbps full duplex
Transmission mode	100BASE-TX
Autonegotiation	Yes
Bus protocol	PROFINET IO <ul style="list-style-type: none"> <li>• IRT with the option "high flexibility"</li> <li>• IRT with the option "high performance"</li> </ul>
Supported Ethernet services	PROFINET IO (Device) <ul style="list-style-type: none"> <li>• ping</li> <li>• arp</li> <li>• LLDP</li> <li>• Network diagnostics (SNMP)</li> <li>• DCP</li> <li>• Prioritized startup</li> <li>• Media redundancy</li> </ul>
<b>PROFINET interface</b>	
• Connection socket	2 x M12 d-coded
• Switch function	Yes, internal
• Auto-crossover	Yes, if autonegotiation is enabled
Manufacturer ID (Vendor ID)	002A <sub>H</sub>
Device ID (DeviceID)	0306 <sub>H</sub>
<b>Voltages and currents</b>	
Supply voltage 1L+	DC 24 V
• Reverse polarity protection	Yes, against destruction, loads are activated
• Infeed current 1L+	Max. 4 A
Supply voltage 2L+	DC 24 V
• Reverse polarity protection	Yes, against destruction, loads are activated
• Infeed current 2L+	Max. 4 A
Total current of the outputs *	
• All mounting positions to 55°C	3.9 A per 1L+ and 2L+
• All mounting positions to 60°C	2.6 A per 1L+ and 2L+
<b>Current consumption</b>	
From supply voltage (1L+)	Typ. 100 mA
Power loss of the device	Typ. 5.5 W
<b>Digital outputs</b>	
Number of outputs	8

<b>Technical specifications</b>	
<b>Insulation</b>	
Insulation test voltage	
• Ethernet interface	1500 V <sub>rms</sub> (IEEE802.3, Type Test)
• All other circuit elements	707 V DC (type test)
<b>Electrical isolation</b>	
• Between 1L+ and 2L+	Yes
• Between 1L+, channels and all other circuit elements	No
• Between channels	No
• Between Ethernet and all other circuit elements	Yes
<b>Status, interrupts, diagnostics</b>	
Interrupts	Yes
Diagnostics function	Yes
• Group error/maintenance	Red/yellow "SF/MT" LED
• Bus monitoring PROFINET IO	Red "BF" LED
• Monitoring of supply voltage 1L+	Green "ON" LED
• Monitoring of supply voltage 2L+	Green "DC24V" LED
• Existing connection to network	Green "P1 LK" and "P2 LK" LED; LED for PROFINET IO infeed and loop-through
• Digital output	Green LED
• Fault at digital output	Red LED
• Diagnostic information can be read	Yes
Monitoring for	
• Short-circuit	Yes
• Wire break	Yes, in the off state, per channel
• Failure of 1L+ and 2L+	Yes
<b>Actuator selection data</b>	
Cable length, shielded	Max. 30 m
Cable length, unshielded	Max. 30 m
Output voltage	
• Nominal value	DC 24 V
• For signal "1"	Min. 1L+/2L+ (-0.8 V)
Output current	
• At signal "1"	Max. 1.3 A
• For "0" signal (residual current)	Max. 1.5 mA
Load resistance range	22 Ω to 3.3 kΩ
Lamp load	Max. 5 W

Technical specifications	
Parallel wiring of two outputs	
• To increase performance	No
• For redundant control of a load	Supported
Controlling of a digital input	
	Yes
Switching frequency	
• With resistive load	Max. 100 Hz
• With inductive load	Max. 0.5 Hz
• With lamp load	Max. 1 Hz
Limiting of the inductive shutdown voltage to lamp load	
	Typ. 1L+/2L+ (-47 V)
Short-circuit protection of the output	
	Yes, electronic
• Response threshold	Typ. 1.8 A (per channel)
* Make allowances for the maximum total current when configuring the module.	

## 9.2.2 I/O device 8 DO DC 24 V/0.5A 4xM12

### Article number

6ES7142-6BF50-0AB0

### Properties

The 8 DO DC 24V/0,5A 4xM12 I/O device has the following properties:

- 8 digital outputs
- Dimensions 30 x 200 mm, dual assignment of the sockets
- Output current: 0.5 A per output
- Rated load voltage DC 24 V
- Suitable for solenoid valves, DC contactors, and indicator lights
- Diagnostics
  - "Missing 1L+ or 2L+" for the I/O device
  - "Wire break at outputs" per channel
  - "Short-circuit to M at outputs" per channel
- Parameterizable response to CPU/Master STOP
- Prioritized startup
- Media redundancy

### Pin assignment of the sockets

The table below shows the pin assignment of the four sockets for connecting digital outputs.

Table 9- 5 Pin assignment of sockets X1 to X4 for digital outputs

Pin	Assignment				View of socket (front view)
	Socket X1	Socket X2	Socket X3	Socket X4	
1	Not used				
2	Output signal				
	DQ4	DQ5	DQ6	DQ7	
3	Ground 2M				
4	Output signal				
	DQ0	DQ1	DQ2	DQ3	
5	Functional earth FE				

### Block diagram

The block diagram below shows the 8 DO DC 24V/0,5A 4xM12 I/O device.

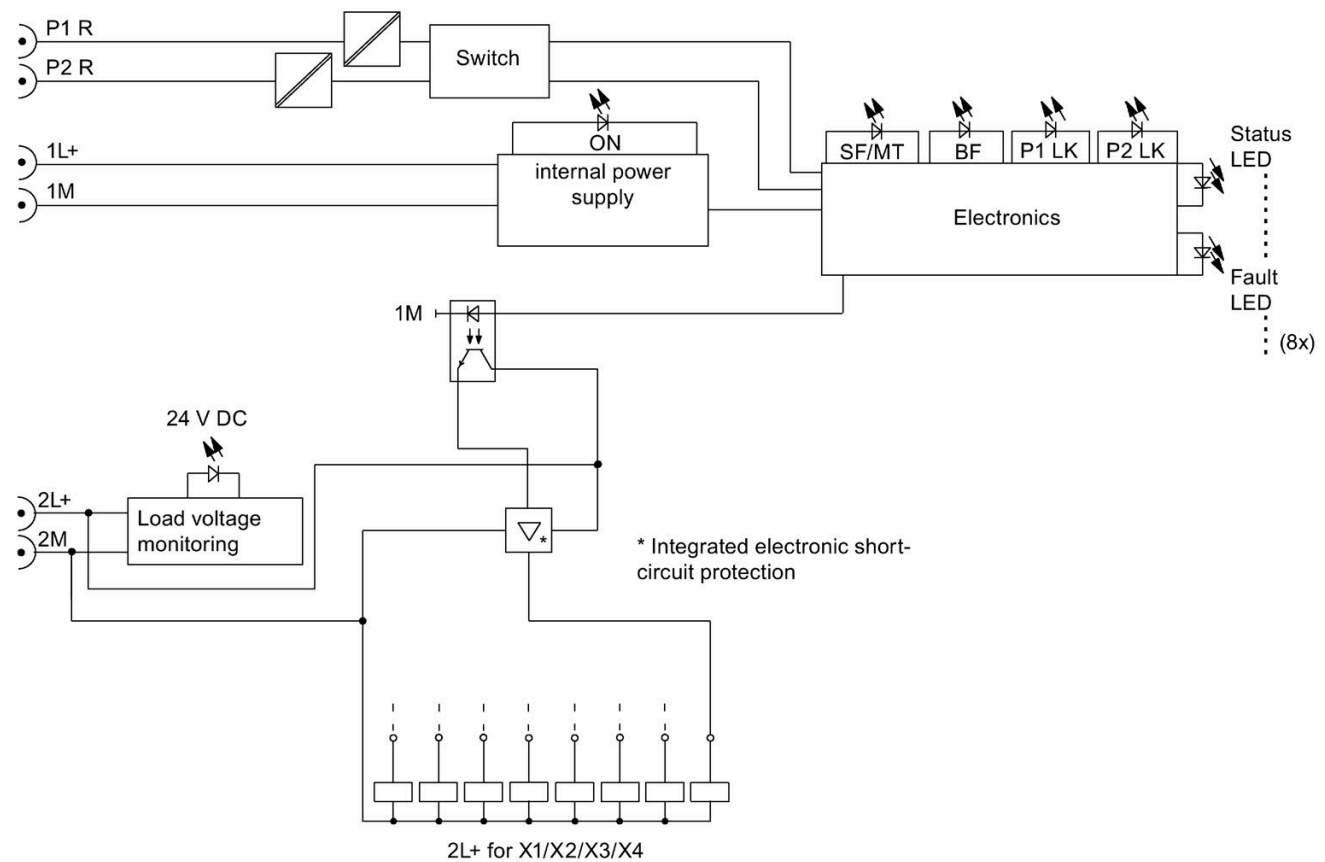

Figure 9-5 Block diagram of the 8 DO DC 24V/0,5 A 4xM12 I/O device



### Technical data of the 8 DO DC 24V/0,5A 4×M12 I/O device

Technical data	
<b>Dimensions and weight</b>	
Dimensions W x H x D (mm)	30 x 200 x 49
Weight	Approx. 550 g
<b>Module-specific data</b>	
Transmission rate	100 Mbps full duplex
Transmission mode	100BASE-TX
Autonegotiation	Yes
Bus protocol	PROFINET IO <ul style="list-style-type: none"> <li>• IRT with the option "high flexibility"</li> <li>• IRT with the option "high performance"</li> </ul>
Supported Ethernet services	PROFINET IO (Device) <ul style="list-style-type: none"> <li>• ping</li> <li>• arp</li> <li>• LLDP</li> <li>• Network diagnostics (SNMP)</li> <li>• DCP</li> <li>• Prioritized startup</li> <li>• Media redundancy</li> </ul>
<b>PROFINET interface</b>	
• Connection socket	2 x M12
• Switch function	Yes, internal
• Auto-crossover	Yes, if autonegotiation is enabled
Manufacturer ID (Vendor ID)	002A <sub>H</sub>
Device ID (DeviceID)	0306 <sub>H</sub>
<b>Voltages and currents</b>	
Supply voltage 1L+	DC 24 V
• Reverse polarity protection	Yes, against destruction, loads are activated
• Infeed current 1L+	Max. 4 A
Supply voltage 2L+	DC 24 V
• Reverse polarity protection	Yes, against destruction, loads are activated
• Infeed current 2L+	Max. 4 A
<b>Total current of the outputs</b>	
• All mounting positions to 60°C	Max. 4 A (only 2L+)

<b>Technical data</b>	
<b>Electrical isolation</b>	
• Between 1L+ and 2L+	Yes
• Between 1L+, channels and all other circuit elements	No
• Between channels	No
• Between Ethernet and all other circuit elements	Yes
<b>Insulation</b>	
Insulation test voltage	
• Ethernet interface	1500 V <sub>rms</sub> (IEEE802.3, Type Test)
• All other circuit elements	707 V DC (type test)
<b>Current consumption</b>	
• From supply voltage (1L+)	Typ. 100 mA
• From supply voltage (2L+)	Typ. 5 mA
Power loss of the device	Typ. 3 W
<b>Digital outputs</b>	
Number of outputs	8
<b>Status, interrupts, diagnostics</b>	
Interrupts	Yes
Diagnostics function	Yes
• Group error/maintenance	Red/yellow "SF/MT" LED
• Bus monitoring PROFINET IO	Red "BF" LED
• Monitoring of supply voltage 1L+	Green "ON" LED
• Monitoring of supply voltage 2L+	Green "DC24V" LED
• Existing connection to network	Green LED "P1 LK" and "P2 LK";
• Digital output	Green LED
• Fault at digital output	Red LED
• Diagnostic information can be read	Yes
Monitoring for	
• Failures of 2L+	Yes
• Short-circuit	Yes
• Wire break	Yes, in the off state, per channel
<b>Actuator selection data</b>	
Cable length, shielded	Max. 30 m
Cable length, unshielded	Max. 30 m
Output voltage	
• Nominal value	DC 24 V
• For signal "1"	Min. 1L+/2L+ (-0.8 V)

Technical data	
Output current	
• At signal "1"	0.5 A
• For "0" signal (residual current)	Max. 1.5 mA
Load resistance range	48 $\Omega$ to 3.3 k $\Omega$
Lamp load	Max. 5 W
Parallel wiring of two outputs	
• To increase performance	No
• For redundant control of a load	Supported
Control of a digital input	Yes
Switching frequency	
• With resistive load	Max. 100 Hz
• With inductive load	Max. 0.5 Hz
• With lamp load	Max. 1 Hz
Limiting of the inductive shutdown voltage to lamp load	Typ. 1L+/2L+ (-47 V)
Short-circuit protection of the output	Yes, electronic
• Response threshold	Typ. 0.7 A (per channel)

### 9.2.3 I/O device 8 DO DC 24 V/1.3A 8xM12

#### Article number

6ES7142-6BG00-0AB0

#### Properties

The 8 DO DC 24V/1,3A 8xM12 I/O device has the following properties:

- 8 digital outputs
- Dimensions 60 x 175 mm, single assignment of the sockets
- Output current: 1.3 A per output
- Rated load voltage DC 24 V
- Suitable for solenoid valves, DC contactors, and indicator lights
- Diagnostics
  - "Missing 1L+ or 2L+" for the I/O device
  - "Wire break at outputs" per channel
  - "Short-circuit to M at outputs" per channel
- Parameterizable response to CPU/Master STOP
- Prioritized startup
- Media redundancy

**Pin assignment of the sockets**

The table below shows the pin assignment of the eight sockets for connecting digital outputs.

Table 9- 6 Pin assignment of sockets X1 to X8 for digital outputs

Pin	Assignment								View of socket (front view)
	Socket X1	Socket X2	Socket X3	Socket X4	Socket X5	Socket X6	Socket X7	Socket X8	
	24 V (1L+ non-switched)				24 V (2L+ switched)				
1	Not used								
2	Not used								
3	Ground 1M				Ground 2M				
4	Output signal								
	DQ <sub>0</sub>	DQ <sub>1</sub>	DQ <sub>2</sub>	DQ <sub>3</sub>	DQ <sub>4</sub>	DQ <sub>5</sub>	DQ <sub>6</sub>	DQ <sub>7</sub>	
5	Functional earth FE								

**Block diagram**

The block diagram below shows the 8 DO DC 24V/1,3A 8×M12 I/O device.

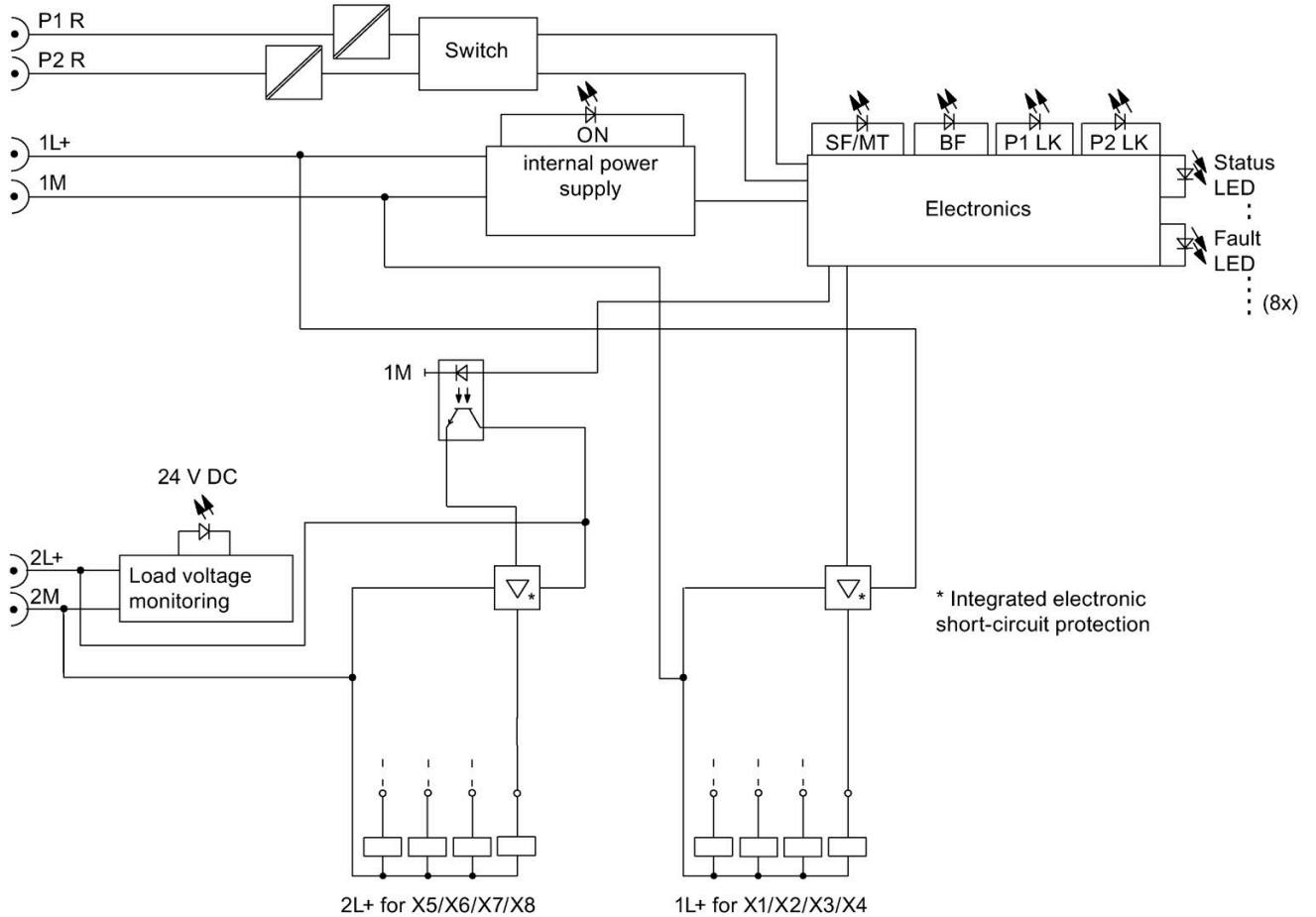

Figure 9-6 Block diagram of the 8 DO DC 24V/1,3A 8×M12 I/O device

## Technical data of the 8 DO DC 24V/1,3A 8×M12 I/O device

Technical data	
<b>Dimensions and weight</b>	
Dimensions W x H x D (mm)	60 x 175 x 49
Weight	Approx. 910 g
<b>Module-specific data</b>	
Transmission rate	100 Mbps full duplex
Transmission mode	100BASE-TX
Autonegotiation	Yes
Bus protocol	PROFINET IO <ul style="list-style-type: none"> <li>• IRT with the option "high flexibility"</li> <li>• IRT with the option "high performance"</li> </ul>
Supported Ethernet services	PROFINET IO (Device) <ul style="list-style-type: none"> <li>• ping</li> <li>• arp</li> <li>• LLDP</li> <li>• Network diagnostics (SNMP)</li> <li>• DCP</li> <li>• Prioritized startup</li> <li>• Media redundancy</li> </ul>
<b>PROFINET interface</b>	
• Connection socket	2 x M12 d-coded
• Switch function	Yes, internal
• Auto-crossover	Yes, if autonegotiation is enabled
Manufacturer ID (Vendor ID)	002A <sub>H</sub>
Device ID (DeviceID)	0306 <sub>H</sub>
<b>Voltages and currents</b>	
Supply voltage 1L+	DC 24 V
• Reverse polarity protection	Yes, against destruction, loads are activated
• Infeed current 1L+	Max. 4 A
Supply voltage 2L+	DC 24 V
• Reverse polarity protection	Yes, against destruction, loads are activated
• Infeed current 2L+	Max. 4 A
Total current of the outputs *	
• All mounting positions to 60°C	Max. 3.9 A per 1L+ and 2L+
<b>Current consumption</b>	
From supply voltage (1L+)	Typ. 100 mA
From supply voltage (2L+)	Typ. 5 mA
Power loss of the device	Typ. 5.5 W
<b>Digital outputs</b>	
Number of outputs	8

<b>Technical data</b>	
<b>Insulation</b>	
Insulation test voltage	
• Ethernet interface	1500 V <sub>rms</sub> (IEEE802.3, Type Test)
• All other circuit elements	707 V DC (type test)
<b>Electrical isolation</b>	
• Between 1L+ and 2L+	Yes
• Between 1L+, channels and all other circuit elements	No
• Between channels	No
• Between Ethernet and all other circuit elements	Yes
<b>Status, interrupts, diagnostics</b>	
Interrupts	Yes
Diagnostics function	Yes
• Group error/maintenance	Red/yellow "SF/MT" LED
• Bus monitoring PROFINET IO	Red "BF" LED
• Monitoring of supply voltage 1L+	Green "ON" LED
• Monitoring of supply voltage 2L+	Green "DC24V" LED
• Existing connection to network	Green "P1 LK" and "P2 LK" LED; LED for PROFINET IO infeed and loop-through
• Digital output	Green LED
• Fault at digital output	Red LED
• Diagnostic information can be read	Yes
Monitoring for	
• Failure of 1L+ and 2L+	Yes
• Short-circuit	Yes, per channel
• Wire break	Yes, in the off state, per channel
<b>Actuator selection data</b>	
Cable length, shielded	Max. 30 m
Cable length, unshielded	Max. 30 m
Output voltage	
• Nominal value	DC 24 V
• For signal "1"	Min. 1L+/2L+ (-0.8 V)
Output current	
• At signal "1"	Max. 1.3 A
• For "0" signal (residual current)	Max. 1.5 mA
Load resistance range	22 Ω to 3.3 kΩ
Lamp load	Max. 5 W

Technical data	
Parallel wiring of two outputs	
• To increase performance	No
• For redundant control of a load	Supported
Control of a digital input	Yes
Switching frequency	
• With resistive load	Max. 100 Hz
• With inductive load	Max. 0.5 Hz
• With lamp load	Max. 1 Hz
Limiting of the inductive shutdown voltage to lamp load	Typ. 1L+/2L+ (-47 V)
Short-circuit protection of the output	Yes, electronic
• Response threshold	Typ. 1.8 A (per channel)
* Make allowances for the maximum total current when configuring the module.	

#### 9.2.4 I/O device 8 DO DC 24V/2.0A 8xM12

##### Article number

6ES7142-6BR00-0AB0

##### Properties

The 8 DO DC 24V/2,0A 8xM12 I/O device has the following properties:

- 8 digital outputs
- Dimensions 60 x 175 mm, single assignment of the sockets
- Output current: 2.0 A per output
- Rated load voltage DC 24 V
- Suitable for solenoid valves, DC contactors, and indicator lights
- Diagnostics
  - "Missing 1L+ or 2L+" for the I/O device
  - "Wire break at outputs" per channel
  - "Short-circuit to M at outputs" per channel
- Parameterizable response to CPU/Master STOP
- Prioritized startup
- Media redundancy



## Pin assignment of the sockets

The table below shows the pin assignment of the eight sockets for connecting digital outputs.

Table 9- 7 Pin assignment of sockets X1 to X8 for digital outputs

Pin	Assignment								View of socket (front view)
	Socket X1	Socket X2	Socket X3	Socket X4	Socket X5	Socket X6	Socket X7	Socket X8	
	24 V (1L+ non-switched)				24 V (2L+ switched)				
1	Not used								
2	Not used								
3	Ground 1M				Ground 2M				
4	Output signal								
	DQ <sub>0</sub>	DQ <sub>1</sub>	DQ <sub>2</sub>	DQ <sub>3</sub>	DQ <sub>4</sub>	DQ <sub>5</sub>	DQ <sub>6</sub>	DQ <sub>7</sub>	
5	Functional earth FE								

**Block diagram**

The block diagram below shows the 8 DO DC 24V/2,0A 8xM12 I/O device.

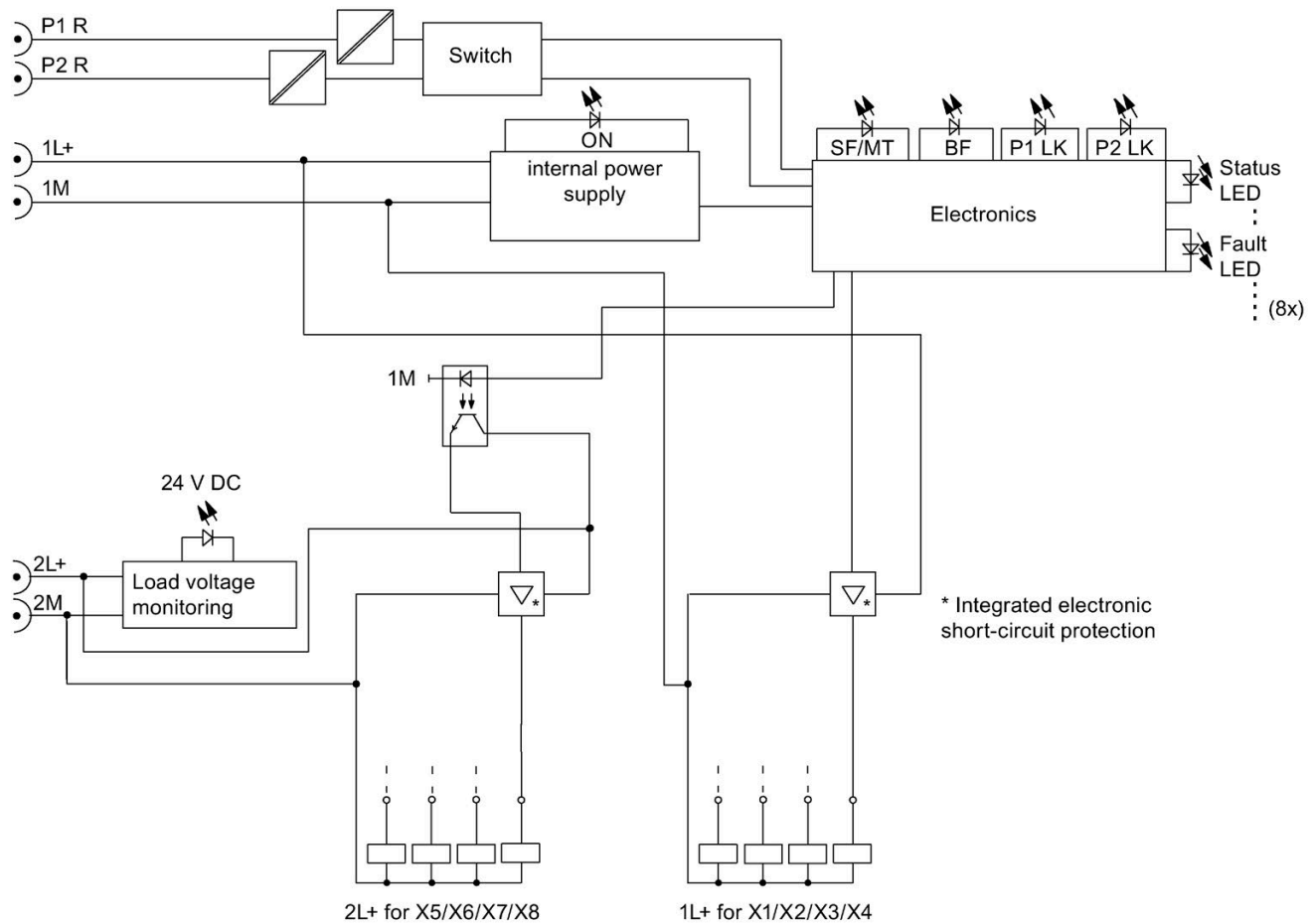

Figure 9-7 Block diagram of the 8 DO DC 24V/2,0A 8xM12 I/O device

## Technical data of the 8 DO DC 24V/2,0A 8×M12 I/O device

<b>Technical data</b>	
<b>Dimensions and weight</b>	
Dimensions W x H x D (mm)	60 x 175 x 49
Weight	Approx. 910 g
<b>Module-specific data</b>	
Transmission rate	100 Mbps full duplex
Transmission mode	100BASE-TX
Autonegotiation	Yes
Bus protocol	PROFINET IO <ul style="list-style-type: none"> <li>• IRT with the option "high flexibility"</li> <li>• IRT with the option "high performance"</li> </ul>
Supported Ethernet services	PROFINET IO (Device) <ul style="list-style-type: none"> <li>• ping</li> <li>• arp</li> <li>• LLDP</li> <li>• Network diagnostics (SNMP)</li> <li>• DCP</li> <li>• Prioritized startup</li> <li>• Media redundancy</li> </ul>
<b>PROFINET interface</b>	
• Connection socket	2 x M12 d-coded
• Switch function	Yes, internal
• Auto-crossover	Yes, if autonegotiation is enabled
Manufacturer ID (Vendor ID)	002A <sub>H</sub>
Device ID (DeviceID)	0306 <sub>H</sub>
<b>Voltages and currents</b>	
Supply voltage 1L+	DC 24 V
• Reverse polarity protection	Yes, against destruction, loads are activated
• Infeed current 1L+	Max. 4 A
Supply voltage 2L+	DC 24 V
• Reverse polarity protection	Yes, against destruction, loads are activated
• Infeed current 2L+	Max. 4 A
Total current of the outputs *	
• All mounting positions to 60°C	Max. 3.9 A 1L+ and max. 4 A 2L+
<b>Current consumption</b>	
From supply voltage (1L+)	Typ. 100 mA
From supply voltage (2L+)	Typ. 5 mA
Power loss of the device	Typ. 5 W
<b>Digital outputs</b>	
Number of outputs	8

<b>Technical data</b>	
<b>Insulation</b>	
Insulation test voltage	
• Ethernet interface	1500 V <sub>rms</sub> (IEEE802.3, Type Test)
• All other circuit elements	707 V DC (type test)
<b>Electrical isolation</b>	
• Between 1L+ and 2L+	Yes
• Between 1L+, channels and all other circuit elements	No
• Between channels	No
• Between Ethernet and all other circuit elements	Yes
<b>Status, interrupts, diagnostics</b>	
Interrupts	Yes
Diagnostics function	Yes
• Group error/maintenance	Red/yellow "SF/MT" LED
• Bus monitoring PROFINET IO	Red "BF" LED
• Monitoring of supply voltage 1L+	Green "ON" LED
• Monitoring of supply voltage 2L+	Green "DC24V" LED
• Existing connection to network	Green "P1 LK" and "P2 LK" LED; LED for PROFINET IO infeed and loop-through
• Digital output	Green LED
• Fault at digital output	Red LED
• Diagnostic information can be read	Yes
Monitoring for	
• Failure of 1L+ and 2L+	Yes
• Short-circuit	Yes, per channel
• Wire break	Yes, in the off state, per channel
<b>Actuator selection data</b>	
Cable length, shielded	Max. 30 m
Cable length, unshielded	Max. 30 m
Output voltage	
• Nominal value	DC 24 V
• For signal "1"	Min. 1L+/2L+ (-0.8 V)
Output current	
• At signal "1"	2.0 A
• For "0" signal (residual current)	Max. 1.5 mA
Load resistance range	12 Ω to 3.3 kΩ
Lamp load	Max. 10 W

Technical data	
Parallel wiring of two outputs	
• To increase performance	No
• For redundant control of a load	Supported
Control of a digital input	Yes
Switching frequency	
• With resistive load	Max. 100 Hz
• With inductive load	Max. 0.5 Hz
• With lamp load	Max. 1 Hz
Limiting of the inductive shutdown voltage to lamp load	Typ. 1L+/2L+ (-47 V)
Short-circuit protection of the output	Yes, electronic
• Response threshold	Typ. 2.8 A (per channel)
* Make allowances for the maximum total current when configuring the module.	

## 9.2.5 I/O device 16 DO DC 24 V/1.3A 8xM12

### Article number

6ES7142-6BH00-0AB0

### Properties

The 16 DO DC 24V/1,3A 8xM12 I/O device has the following properties:

- 16 digital outputs
- Dimensions 60 x 175 mm, dual assignment of the sockets
- Output current: 1.3 A per output
- Rated load voltage DC 24 V
- Suitable for solenoid valves, DC contactors, and indicator lights
- Diagnostics
  - "Missing 1L+ and 2L+" for the I/O device
  - "Wire break at outputs" per channel
  - "Short-circuit to M at outputs" per channel
- Parameterizable response to CPU/Master STOP
- Prioritized startup
- Media redundancy

### Pin assignment of the sockets

The table below shows the pin assignment of the eight sockets for connecting digital outputs.

Table 9- 8 Pin assignment of sockets X1 to X8 for digital outputs

Pin	Assignment								View of socket (front view)
	Socket X1	Socket X2	Socket X3	Socket X4	Socket X5	Socket X6	Socket X7	Socket X8	
	24 V (1L+ non-switched)				24 V (2L+ switched)				
1	Not used								
2	Output signal								
	DQ <sub>8</sub>	DQ <sub>9</sub>	DQ <sub>10</sub>	DQ <sub>11</sub>	DQ <sub>12</sub>	DQ <sub>13</sub>	DQ <sub>14</sub>	DQ <sub>15</sub>	
3	Ground 1M				Ground 2M				
4	Output signal								
	DQ <sub>0</sub>	DQ <sub>1</sub>	DQ <sub>2</sub>	DQ <sub>3</sub>	DQ <sub>4</sub>	DQ <sub>5</sub>	DQ <sub>6</sub>	DQ <sub>7</sub>	
5	Functional earth FE								

**Block diagram**

The block diagram below shows the 16 DO DC 24V/1,3A 8xM12 I/O device.

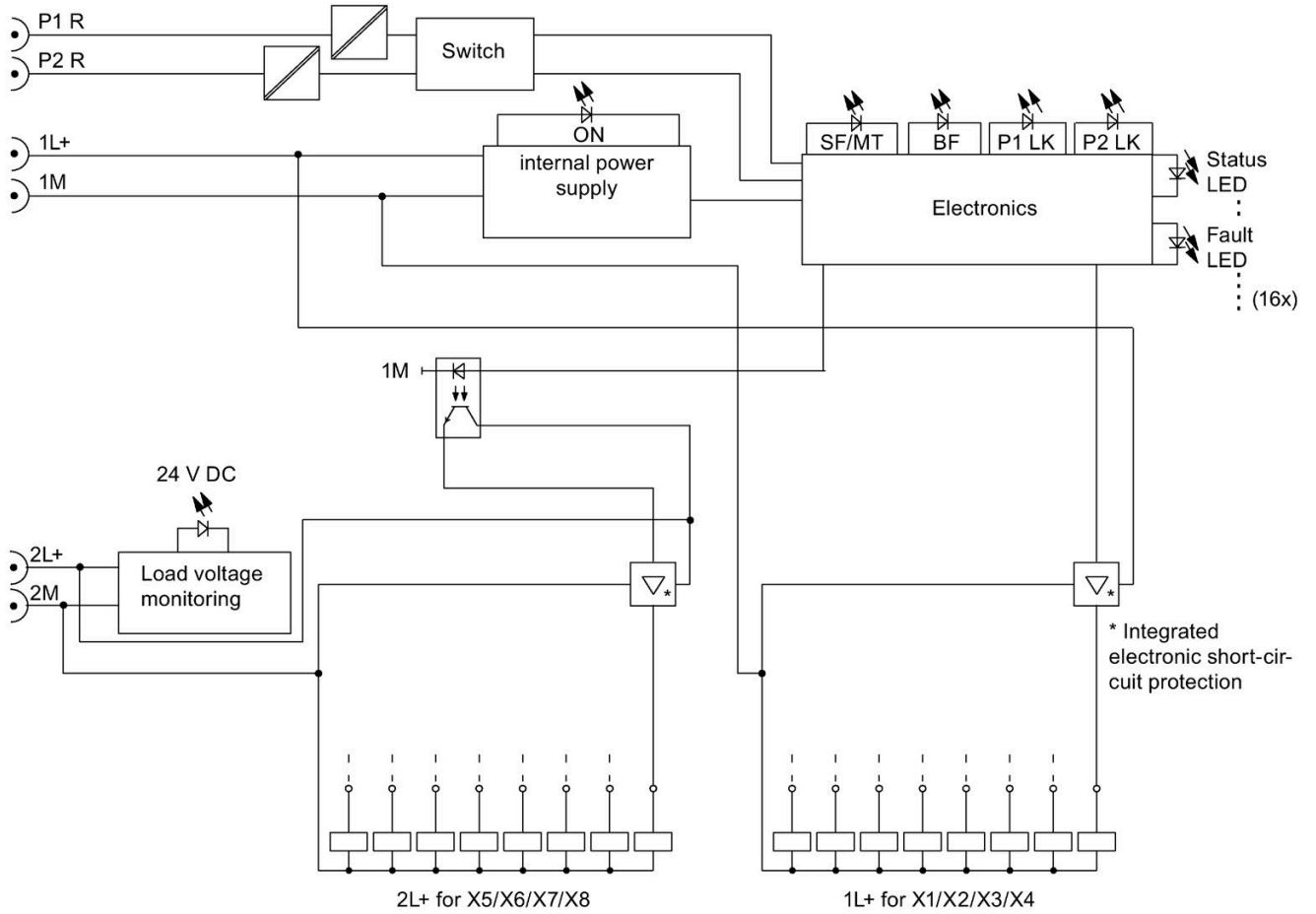

Figure 9-8 Block diagram of the 16 DO DC 24V/1,3A 8xM12 I/O device

## Technical data of the 16 DO DC 24V/1,3A 8×M12 I/O device

Technical data	
<b>Dimensions and weight</b>	
Dimensions W x H x D (mm)	60 x 175 x 49
Weight	Approx. 910 g
<b>Module-specific data</b>	
Transmission rate	100 Mbps full duplex
Transmission mode	100BASE-TX
Autonegotiation	Yes
Bus protocol	PROFINET IO <ul style="list-style-type: none"> <li>• IRT with the option "high flexibility"</li> <li>• IRT with the option "high performance"</li> </ul>
Supported Ethernet services	PROFINET IO (Device) <ul style="list-style-type: none"> <li>• ping</li> <li>• arp</li> <li>• LLDP</li> <li>• Network diagnostics (SNMP)</li> <li>• DCP</li> <li>• Prioritized startup</li> <li>• Media redundancy</li> </ul>
<b>PROFINET interface</b>	
• Connection socket	2 x M12 d-coded
• Switch function	Yes, internal
• Auto-crossover	Yes, if autonegotiation is enabled
Manufacturer ID (Vendor ID)	002A <sub>H</sub>
Device ID (DeviceID)	0306 <sub>H</sub>
<b>Voltages and currents</b>	
Supply voltage 1L+	DC 24 V
• Reverse polarity protection	Yes, against destruction, loads are activated
• Infeed current 1L+	Max. 4 A
Supply voltage 2L+	DC 24 V
• Reverse polarity protection	Yes, against destruction, loads are activated
• Infeed current 2L+	Max. 4 A
Total current of the outputs *	
• All mounting positions to 60°C	Max. 3.9 A per 1L+ and 2L+
<b>Current consumption</b>	
From supply voltage (1L+)	Typ. 100 mA
From supply voltage (2L+)	Typ. 5 mA
Power loss of the device	Typ. 5.5 W
<b>Digital outputs</b>	
Number of outputs	16



<b>Technical data</b>	
<b>Insulation</b>	
Insulation test voltage	
• Ethernet interface	1500 V <sub>rms</sub> (IEEE802.3, Type Test)
• All other circuit elements	707 V DC (type test)
<b>Electrical isolation</b>	
• Between 1L+ and 2L+	Yes
• Between 1L+, channels and all other circuit elements	No
• Between channels	No
• Between Ethernet and all other circuit elements	Yes
<b>Status, interrupts, diagnostics</b>	
Interrupts	Yes
Diagnostics function	Yes
• Group error/maintenance	Red/yellow "SF/MT" LED
• Bus monitoring PROFINET IO	Red "BF" LED
• Monitoring of supply voltage 1L+	Green "ON" LED
• Monitoring of supply voltage 2L+	Green "DC24V" LED
• Existing connection to network	Green "P1 LK" and "P2 LK" LED; LED for PROFINET IO infeed and loop-through
• Digital output	Green LED
• Fault at digital output	Red LED
• Diagnostic information can be read	Yes
Monitoring for	
• Failure of 1L+ and 2L+	Yes
• Short-circuit	Yes, per channel
• Wire break	Yes, in the off state, per channel
<b>Actuator selection data</b>	
Cable length, shielded	Max. 30 m
Cable length, unshielded	Max. 30 m
Output voltage	
• Nominal value	DC 24 V
• For signal "1"	Min. 1L+/2L+ (-0.8 V)
Output current	
• At signal "1"	Max. 1.3 A
• For "0" signal (residual current)	Max. 1.5 mA
Load resistance range	22 Ω to 3.3 kΩ
Lamp load	Max. 5 W

Technical data	
Parallel wiring of two outputs	
• To increase performance	No
• For redundant control of a load	Supported
Control of a digital input	Yes
Switching frequency	
• With resistive load	Max. 100 Hz
• With inductive load	Max. 0.5 Hz
• With lamp load	Max. 1 Hz
Limiting of the inductive shutdown voltage to lamp load	Typ. 1L+/2L+ (-47 V)
Short-circuit protection of the output	Yes, electronic
• Response threshold	Typ. 1.8 A (per channel)
* Make allowances for the maximum total current when configuring the module.	

## 9.2.6 Parameter overview digital outputs

### Parameters for

- 8 DO DC 24V/1,3A 4×M12 (6ES7142-6BF00-0AB0)
- 8 DO DC 24V/1,3A 8×M12 (6ES7142-6BG00-0AB0)
- 8 DO DC 24V/2,0A 8×M12 (6ES7142-6BR00-0AB0)

Parameter	Range of values	Default setting	Range of effectiveness
Group diagnostics	<ul style="list-style-type: none"> <li>• Disable</li> <li>• Enable</li> </ul>	Disable	Device
Diagnostics: Missing 1L+ or 2L+	<ul style="list-style-type: none"> <li>• Disable</li> <li>• Enable</li> </ul>	Disable	Channel group
Response to CPU/Master STOP	<ul style="list-style-type: none"> <li>• Shut down</li> <li>• Retain last value</li> </ul>	Shut down	Device
Diagnostics: Wire break at outputs 0 to 7 (channels 0 to 7)	<ul style="list-style-type: none"> <li>• Disable</li> <li>• Enable</li> </ul>	Disable	Channel
Diagnostics: Short circuit to M, outputs 0 to 7 (channels 0 to 7)	<ul style="list-style-type: none"> <li>• Disable</li> <li>• Enable</li> </ul>	Disable	Channel

**Parameters for 8 DO DC 24V/0,5A 4×M12 (6ES7142-6BF50-0AB0)**

Parameter	Range of values	Default setting	Range of effectiveness
Group diagnostics	<ul style="list-style-type: none"> <li>• Disable</li> <li>• Enable</li> </ul>	Disable	Device
Diagnostics: Missing 2L+	<ul style="list-style-type: none"> <li>• Disable</li> <li>• Enable</li> </ul>	Disable	Device
Response to CPU/Master STOP	<ul style="list-style-type: none"> <li>• Shut down</li> <li>• Retain last value</li> </ul>	Shut down	Device
Diagnostics: Wire break at outputs 0 to 7 (channels 0 to 7)	<ul style="list-style-type: none"> <li>• Disable</li> <li>• Enable</li> </ul>	Disable	Channel
Diagnostics: Short circuit to M, outputs 0 to 7 (channels 0 to 7)	<ul style="list-style-type: none"> <li>• Disable</li> <li>• Enable</li> </ul>	Disable	Channel

**Parameters for 16 DO DC 24V/1,3A 8×M12 (6ES7142-6BH00-0AB0)**

Parameter	Range of values	Default setting	Range of effectiveness
Group diagnostics	<ul style="list-style-type: none"> <li>• Disable</li> <li>• Enable</li> </ul>	Disable	Device
Diagnostics: Missing 1L+ or 2L+	<ul style="list-style-type: none"> <li>• Disable</li> <li>• Enable</li> </ul>	Disable	Channel group
Response to CPU/Master STOP	<ul style="list-style-type: none"> <li>• Shut down</li> <li>• Retain last value</li> </ul>	Shut down	Device
Diagnostics: Wire break at outputs 0 to 15 (channels 0 to 15)	<ul style="list-style-type: none"> <li>• Disable</li> <li>• Enable</li> </ul>	Disable	Channel
Diagnostics: Short circuit to M, outputs 0 to 15 (channels 0 to 15)	<ul style="list-style-type: none"> <li>• Disable</li> <li>• Enable</li> </ul>	Disable	Channel

## 9.3 I/O device digital inputs/digital outputs

### 9.3.1 I/O device 8 DIO DC 24V/1.3A 8xM12

#### Article number

6ES7147-6BG00-0AB0

#### Properties

The 8 DIO DC 24V/1,3A 8xM12 I/O device has the following properties:

- 8 freely parameterizable digital inputs/outputs
- Prioritized startup
- Media redundancy
- Dimensions 60 x 175 mm, single assignment of the sockets
- Digital inputs
  - Rated input voltage DC 24 V
  - Suitable for switches and proximity switches
  - Diagnostics
    - "Missing 1L+ or 2L+" for the I/O device
    - "Short-circuit to M at sensor supply", per channel group
    - "Wire break", per channel
- Digital outputs
  - Rated load voltage DC 24 V
  - Output current: 1.3 A per output
  - Suitable for solenoid valves, DC contactors, and indicator lights
  - Diagnostics
    - "Missing 1L+ or 2L+" for the I/O device
    - "Wire break at outputs" per channel
    - "Short-circuit to M at outputs" per channel
  - Parameterizable response to CPU/Master STOP for I/O device

### Pin assignment of the DIO sockets

The table below shows the pin assignment of the eight sockets for connecting digital inputs and digital outputs.

Table 9-9 Pin assignment of sockets X1 to X8 for digital inputs/digital outputs

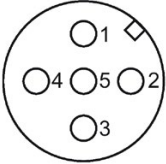
Pin	Assignment								View of socket (front view)
	Socket X1	Socket X2	Socket X3	Socket X4	Socket X5	Socket X6	Socket X7	Socket X8	
1	24 V sensor supply 1Us (derived from 1L+ non-switched)				24 V sensor supply 2Us (derived from 2L+ switched)				X01 - X04 
2	Not used								
3	Supply ground 1M				Supply ground 2M				
4	Input/output signal								
	DIQ <sub>0</sub>	DIQ <sub>1</sub>	DIQ <sub>2</sub>	DIQ <sub>3</sub>	DIQ <sub>4</sub>	DIQ <sub>5</sub>	DIQ <sub>6</sub>	DIQ <sub>7</sub>	
5	Functional earth FE								

**Block diagram**

The block diagram below shows the 8 DIO DC 24V/1,3A 8xM12 I/O device.

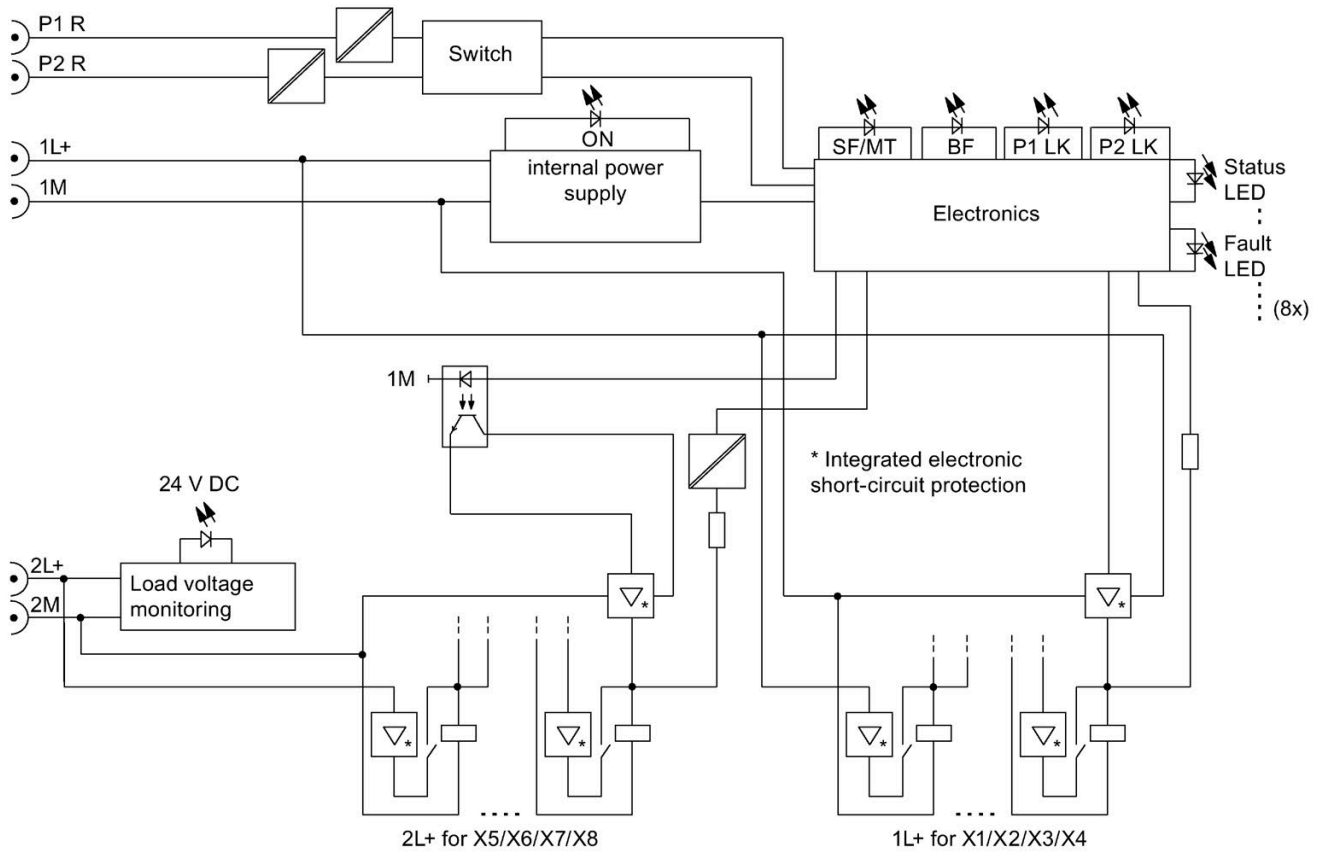

Figure 9-9 Block diagram of the 8 DIO DC 24V/1,3A 8xM12 I/O device

## Technical data of the 8 DIO DC 24V/1,3A 8×M12 I/O device

<b>Technical data</b>	
<b>Dimensions and weight</b>	
Dimensions W x H x D (mm)	60 x 175 x 49
Weight	Approx. 910 g
<b>Module-specific data</b>	
Transmission rate	100 Mbps full duplex
Transmission mode	100BASE-TX
Autonegotiation	Yes
Bus protocol	PROFINET IO <ul style="list-style-type: none"> <li>• IRT with the option "high flexibility"</li> <li>• IRT with the option "high performance"</li> </ul>
Supported Ethernet services	PROFINET IO (Device) <ul style="list-style-type: none"> <li>• ping</li> <li>• arp</li> <li>• LLDP</li> <li>• Network diagnostics (SNMP)</li> <li>• DCP</li> <li>• Prioritized startup</li> <li>• Media redundancy</li> </ul>
<b>PROFINET interface</b>	
• Connection socket	2 x M12 d-coded
• Switch function	Yes, internal
• Auto-crossover	Yes, if autonegotiation is enabled
Manufacturer ID (Vendor ID)	002A <sub>H</sub>
Device ID (DeviceID)	0306 <sub>H</sub>
<b>Voltages and currents</b>	
Supply voltage 1L+	DC 24 V
• Reverse polarity protection	Yes, against destruction, loads are activated
• Infeed current 1L+	Max. 4 A
Supply voltage 2L+	DC 24 V
• Reverse polarity protection	Yes, against destruction, loads are activated
• Infeed current 2L+	Max. 4 A
<b>Current consumption</b>	
From supply voltage (1L+)	Typ. 100 mA (no digital output activated)
From supply voltage (2L+)	Typ. 5 mA (no digital output activated)
Power loss of the device	type 4.5 W (if all channels are set as digital input) type 6.5 W (if all channels are set as digital output)
<b>Total current of the outputs</b>	
• All mounting positions to 60°C	Max. 3.9 A per 1L+ and 2L+

<b>Technical data</b>	
<b>Digital inputs/digital outputs</b>	
Number of configurable inputs/outputs	8
Number of inputs that can be controlled simultaneously	8, in all mounting positions
<b>Insulation</b>	
Insulation test voltage	
• Ethernet interface	1500 V <sub>rms</sub> (IEEE802.3, Type Test)
• All other circuit elements	707 V DC (type test)
<b>Electrical isolation</b>	
• Between 1L+ and 2L+	Yes
• Between 1L+, channels and all other circuit elements	No
• Between channels	No
• Between Ethernet and all other circuit elements	Yes
<b>Status, interrupts, diagnostics</b>	
Interrupts	Yes
Diagnostics function	Yes
• Group error/maintenance	Red/yellow "SF/MT" LED
• Bus monitoring PROFINET IO	Red "BF" LED
• Monitoring of supply voltage 1L+	Green "ON" LED
• Existing connection to network	Green "P1 LK" and "P2 LK" LED; LED for PROFINET IO infeed and loop-through
• Digital input	Green LED
• Fault at digital input	Red LED
• Digital output	Green LED
• Fault at digital output	Red LED
• Diagnostic information can be read	Yes
<b>Monitoring for</b>	
• Failure of 1L+ and 2L+	Yes
• Sensor supply short-circuit	Yes, per channel
• Digital output short-circuit	Yes, per channel
• Digital input wire break	Yes, input current < 0.3 mA, per channel
• Digital output wire break	Yes, in the off state, per channel



<b>Technical data</b>	
<b>Sensor supply</b>	
Number of sensor supplies	8, 4×1L+ and 4×2L+ Note: The sensor supply is only available when the corresponding channel is parameterized as an "Input".
Load current	100 mA per output
Short-circuit protection	Yes, electronic
<b>Sensor selection data</b>	
Cable length, shielded	Max. 30 m
Cable length, unshielded	Max. 30 m
Input voltage	
• Nominal value	24 V DC
• For signal "1"	11 to 30 V
• For signal "0"	-3 to +5 V
Input current	
• At signal "1"	Typ. 7 mA
Input delay	
• At "0" to "1"	Typ. 3 ms
• At "1" to "0"	Typ. 3 ms
Input characteristic	According to IEC 61131, Type 3
Connection of 2-wire proximity switches	
• Permitted quiescent current	Max. 1.5 mA
<b>Actuator selection data</b>	
Cable length, shielded	Max. 30 m
Cable length, unshielded	Max. 30 m
Output voltage	
• Nominal value	24 V DC
• For signal "1"	Min. 1L+/2L+ (-0.8 V)
Output current	
• At signal "1"	Max. 1.3 A
• For "0" signal (residual current)	Max. 1.5 mA
Load resistance range	22 Ω to 3.3 kΩ
Lamp load	Max. 5 W
Parallel wiring of two outputs	
• To increase performance	No
• For redundant control of a load	Supported
Control of a digital input	Yes

Technical data	
Switching frequency	
• With resistive load	Max. 100 Hz
• With inductive load	Max. 0.5 Hz
• With lamp load	Max. 1 Hz
Limiting of the inductive shutdown voltage to lamp load	Typ. 1L+/2L+ (-47 V)
Short-circuit protection of the output	Yes, electronic
• Response threshold	Typ. 1.8 A (per channel)

### 9.3.2 Parameter overview digital inputs/digital outputs

#### Parameters for 8 DIO DC 24V/1,3A 8×M12 (6ES7147-6BG00-0AB0)

Parameters	Range of values	Default setting	Range of effectiveness
Group diagnostics	<ul style="list-style-type: none"> <li>Disable</li> <li>Enable</li> </ul>	Disable	Device
Diagnostics: Missing 1L+ or 2L+	<ul style="list-style-type: none"> <li>Disable</li> <li>Enable</li> </ul>	Disable	Channel group
Diagnostics: Wire break at inputs 0 to 7 (channels 0 to 7)	<ul style="list-style-type: none"> <li>Disable</li> <li>Enable</li> </ul>	Disable	Channel
Diagnostics: Short-circuit to M, inputs 0 to 7	<ul style="list-style-type: none"> <li>Disable</li> <li>Enable</li> </ul>	Disable	Channel
Response to CPU/Master STOP	<ul style="list-style-type: none"> <li>Shut down</li> <li>Retain last value</li> </ul>	Shut down	Device
Diagnostics: Wire break outputs 0 to 7	<ul style="list-style-type: none"> <li>Disable</li> <li>Enable</li> </ul>	Disable	Channel
Diagnostics: Short-circuit to M, outputs 0 to 7	<ul style="list-style-type: none"> <li>Disable</li> <li>Enable</li> </ul>	Disable	Channel
Freely parameterizable	<ul style="list-style-type: none"> <li>Digital input</li> <li>Digital output</li> </ul>	Digital input	Channel

## I/O device analog input/analog output

### 10.1 I/O device analog input

#### 10.1.1 I/O device 8 AI 4 U/I + 4 RTD/TC 8xM12

##### Article number

6ES7144-6KD00-0AB0

##### Properties

- 4 inputs for voltage and current measurement (2-wire and 4-wire transducers)
- 4 inputs for resistance (2-/3-/4-wire transducer), thermal resistor (2-/3-/4-conductor connection system), thermocouple or  $\pm 80$  mV
- Input ranges:
  - $\pm 10$  V, resolution 15 bits + sign
  - $\pm 80$  mV, resolution 15 bps + sign
  - 0 to 10 V, resolution 15 bits
  - 1 to 5 V, resolution 15 bits
  - $\pm 20$  mA, resolution 15 bits + sign
  - 0 to 20 mA, resolution 15 bps + sign
  - 4 to 20 mA, resolution 15 bits
  - 150, 300, 600, 3000  $\Omega$ , resolution 15 bps
  - Ni100, Ni1000, Ni120, Ni200, Ni500, Pt100, Pt1000, Pt200, Pt500, resolution 15 bps + sign
  - E, J, K, N, resolution 15 bps + sign
- Dimensions 60 x 175 mm
- Diagnostics
  - "No 1L+" supply voltage
  - "Sensor supply short-circuit"
  - "Wire break"
  - "Underflow"
  - "Overflow"

10.1 I/O device analog input

- Permitted common-mode voltage AC 10V<sub>PP</sub>
- Prioritized startup
- Media redundancy

**Note**

**During startup**

As long as no parameters are assigned for the I/O device, the I/O device supplies the process values 0x7FFF.

**Pin assignment**

The tables below show the pin assignment for the 8 AI 4 U/I + 4 RTD/TC 8xM12 I/O device.

Table 10- 1 Pin assignment for voltage and current for the 8 AI 4 U/I + 4 RTD/TC 8xM12 I/O device

Pin	Assignment for U/I				View of socket (front view)
	Socket X1 (Channel 0)	Socket X3 (Channel 1)	Socket X5 (Channel 2)	Socket X7 (Channel 3)	
1	24 V sensor supply 1Us(derived from 1L+ non-switched)				
2	Input signal				
	M <sub>0+</sub>	M <sub>1+</sub>	M <sub>2+</sub>	M <sub>3+</sub>	
3	Sensor supply ground 1M				
4	Input signal				
	M <sub>0-</sub>	M <sub>1-</sub>	M <sub>2-</sub>	M <sub>3-</sub>	
5	Functional earth FE				

Table 10- 2 Pin assignment for RTD for the 8 AI 4 U/I + 4 RTD/TC 8×M12 I/O device

Pin	Assignment for RTD				View of socket (front view)	
	Socket X2 (Channel 4)	Socket X4 (Channel 5)	Socket X6 (Channel 6)	Socket X8 (Channel 7)		
<b>4-conductor</b>						
1	Constant current line					
	Ic4+	Ic5+	Ic6+	Ic7+		
2	Measurement cable					
	M4+	M5+	M6+	M7+		
3	Constant current line					
	Ic4-	Ic5-	Ic6-	Ic7-		
4	Measurement cable					
	M4-	M5-	M6-	M7-		
5	Functional earth FE					
<b>3-conductor</b>						
1	Constant current line					
	Ic4+	Ic5+	Ic6+	Ic7+		
2	Measurement cable					
	M4+	M5+	M6+	M7+		
3	Constant current line and measurement cable					
	Ic4-, M4-	Ic5-, M5-	Ic6-, M6-	Ic7-, M7-		
4	Not used					
5	Functional earth FE					
<b>2-conductor</b>						
1	Constant current line and measurement cable					
	Ic4+, M4+	Ic5+, M5+	Ic6+, M6+	Ic7+, M7+		
2	Not used					
3	Constant current line and measurement cable					
	Ic4-, M4-	Ic5-, M5-	Ic6-, M6-	Ic7-, M7-		
4	Not used					
5	Functional earth FE					

Table 10- 3 Pin assignment for thermocouple and voltage  $\pm 80$  mV for 8 AI 4 U/I + 4 RTD/TC 8×M12 I/O device

Pin	Assignment for thermocouples and $\pm 80$ mV				View of socket (front view)
	Socket X2 (Channel 4)	Socket X4 (Channel 5)	Socket X6 (Channel 6)	Socket X8 (Channel 7)	
1	Not used				
2	Input signal				
	M4+	M5+	M6+	M7+	
3	Not used				
4	Input signal				
	M4-	M5-	M6-	M7-	
5	Functional earth FE				

**Block diagram**

The block diagram below shows the 8 AI 4 U/I + 4 RTD/TC 8×M12.

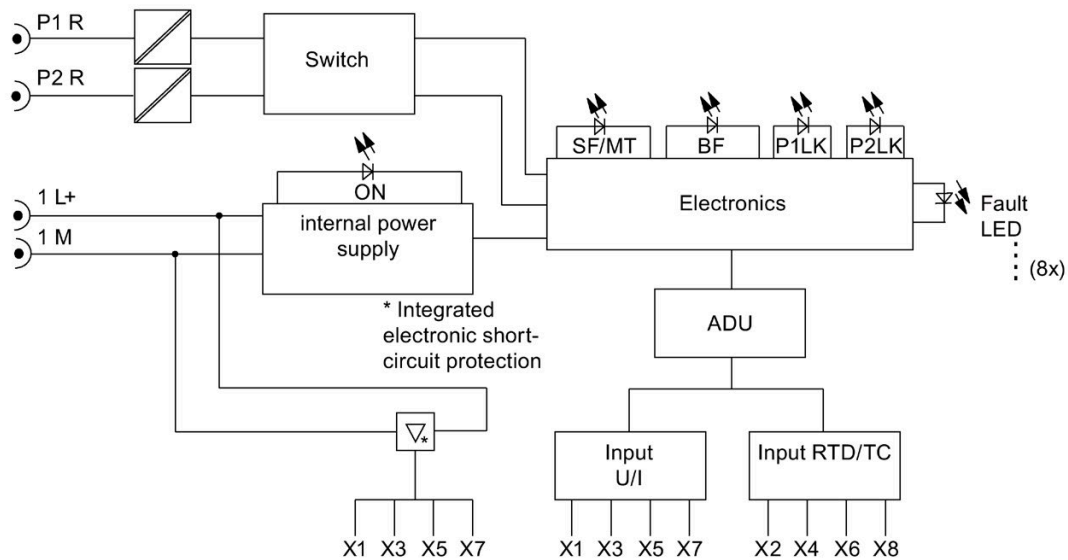

Figure 10-1 Block diagram 8 AI 4 U/I + 4 RTD/TC 8×M12

## Technical specifications

<b>Technical specifications</b>	
<b>Dimensions and weight</b>	
Dimensions W x H x D (mm)	60 x 175 x 49
Weight	Approx. 930 g
<b>Module-specific data</b>	
Transmission rate	100 Mbps full duplex
Transmission mode	100BASE-TX
Autonegotiation	Yes
Bus protocol	PROFINET IO <ul style="list-style-type: none"> <li>• IRT with the option "high flexibility"</li> <li>• IRT with the option "high performance"</li> </ul>
Supported Ethernet services	PROFINET IO (Device) <ul style="list-style-type: none"> <li>• ping</li> <li>• arp</li> <li>• LLDP</li> <li>• Network diagnostics (SNMP)</li> <li>• DCP</li> <li>• Prioritized startup</li> <li>• Media redundancy</li> </ul>
<b>PROFINET interface</b>	
• Connection socket	2 x M12 d-coded
• Switch function	Yes, internal
• Auto-crossover	Yes; if autonegotiation is enabled
Manufacturer ID (Vendor ID)	002A <sub>H</sub>
Device ID (DeviceID)	0306 <sub>H</sub>
<b>Voltages and currents</b>	
Supply voltage 1L+	DC 24 V
Reverse polarity protection	Yes; against destruction
• Infeed current 1L+	Max. 4 A
Supply voltage 2L+	DC 24 V
• Infeed current 2L+	Max. 4 A
<b>Current consumption</b>	
• From supply voltage 1L+	Typ. 110 mA
• From supply voltage 2L+	0 mA
Power loss of the device	Typ. 2.8 W, without sensor current
<b>Analog inputs</b>	
Number of inputs	8 (4 for U or I, 4 for RTD or thermocouple)
Cable length, shielded	Max. 30 m
<b>Sensor supply</b>	
Number of sensor supplies	4

<b>Technical specifications</b>	
Total current	Max. 1 A
Short-circuit protection	Yes; electronic, for each module, to ground
• Response threshold	Min. 1.4 A
<b>Sensor selection data</b>	
Input ranges (Rated value)/input resistance or input voltage	
• Voltage	±80 mV/10 MΩ ±10 V/100 kΩ 0 to 10 V/100 kΩ 1 to 5 V/100 kΩ
• Current	±20 mA/17 V for 2-wire transducer, 3.5 V for 4-wire transducer 0 to 20 mA/17 V for 2-wire transducer, 3.5 V for 4-wire transducer 4 to 20 mA/17 V for 2-wire transducer, 3.5 V for 4-wire transducer
• Resistor and thermal resistor	150 Ω/10 MΩ 300 Ω/10 MΩ 600 Ω/10 MΩ 3000 Ω/10 MΩ Ni100/10 MΩ Ni1000/10 MΩ Ni120/10 MΩ Ni200/10 MΩ Ni500/10 MΩ Pt100/10 MΩ Pt1000/10 MΩ Pt200/10 MΩ Pt500/10 MΩ
• Thermocouple	Types E, J, K, N
Permitted input voltage for voltage input (destruction limit)	28.8 V continuous, 35 V for max. duration of 500 ms
Connection of sensors for voltage measurement	Yes
Connection of sensors for current measurement	Yes (as 2-wire/4-wire transducer)
Connection of sensors for RTD	Yes (with 2-/3-/4-conductor connection)
Connection of sensors for thermocouples	Yes
Temperature compensation for thermocouples <sup>1</sup>	
• Internal temperature compensation	Yes, parameterizable
• External temperature compensation	Yes, parameterizable
Technical unit for temperature measurement	°C, °F, K



Technical specifications					
<b>Formation of analog values</b>					
Measuring principle		Integrating			
Integration time and conversion time/resolution (per channel)					
• Integration time parameterizable		Yes			
• Interference frequency suppression in Hz		500/60/50/10			
• Integration time in ms		2.0/16.667/20/100			
• Conversion time in ms (per channel) <sup>2</sup>		4/19/22/102			
• Resolution for voltage (including overrange)		±80 mV/15 bps + sign ±10 V/15 bps + sign 0 to 10 V/15 bps 1 to 5 V/15 bps			
• Resolution for current (including overrange)		±20 mA/15 bps + sign 0 to 20 mA/15 bps 4 to 20 mA/15 bps			
• Resolution for RTD (including overrange)		150 Ω, 300 Ω, 600 Ω, 3000 Ω/15 bps, Ni100, Ni1000, Ni120, Ni200; Ni500, Pt100, Pt1000, Pt200, Pt500/15 bps + sign			
• Resolution for thermocouples (including overrange)		Types E, J, K, N/15 bps + sign			
Measured value smoothing		Yes, parameterizable in 4 levels			
	<b>Level</b> None Weak Medium Strong	<b>Time constant</b> 1 x cycle time 4 x cycle time 16 x cycle time 64 x cycle time			
<b>Interference suppression, error limits</b>					
Interference suppression for $f = n \times (f_1 \pm 0.5\%)$ , ( $f_1 =$ interference frequency)		46 dB			
• Common-mode interference (interference voltage < 5 V)		70 dB			
• Series-mode interference (peak value of interference < Rated value of input range)		46 dB			
Crosstalk between inputs		< -85 dB			
Operational limit (across temperature range, relative to input range)		Ambient temperature			
			positive	negative (0 °C to -25 °C)	negative (-25 °C to -40 °C)
		U	0.15%	0.2%	0.35%
		I	0.2%	0.25%	0.4%
		R, RTD	0.1%	0.15%	0.3%
Basic error limit (operational limit at 25 °C, relative to input range) <sup>3</sup>		TC		0.4%	
		U		0.1%	
		I		0.1%	
		R, RTD		0.05%	
		TC		0.1%	

<b>Technical specifications</b>		
Temperature error (relative to input range)		Ambient temperature
		positive
		negative
	U	0.0035%/K
	I	0.006%/K
	R, RTD	0.0005%/K
	TC	0.0035%/K
Linearity error (relative to input range)	±0.01%	
Repeat accuracy (in steady-state condition at 25°C, relative to input range)	±0.008%	
Operational limit for internal temperature sensor	±3 °C	
Basic error limit for internal temperature sensor	±2 °C	
<b>Status, interrupts, diagnostics</b>		
Interrupts	Yes	
Diagnostics functions		
• Group error/maintenance	Red/yellow "SF/MT" LED	
• Bus monitoring PROFINET IO	Red "BF" LED	
• Monitoring of supply voltage 1L+	Green "ON" LED	
• Existing connection to bus	Green "P1 LK" and "P2 LK" LED; LED for PROFINET IO infeed and loop-through	
• Analog input error	Red LED	
• Diagnostic information can be read	Yes	
Monitoring for		
• Sensor supply short-circuit	Yes, only if channel is enabled	
• Wire break	4 to 20 mA, 1 to 5 V, resistors and thermoresistors	
• Underflow and overflow	Yes	
• Supply voltage 1L+	Yes	
<b>Insulation</b>		
Insulation test voltage		
• Ethernet interface	1500 V <sub>rms</sub> (IEEE802.3, Type Test)	
• All other circuit elements	707 V DC (type test)	
<b>Standards, approvals, certificates</b>		
Suitable for applications according to AMS 2750	Yes; Declaration of Conformity, see online support entry 109757262	
Suitable for applications according to CQI-9	Yes; based on AMS 2750 E	

Technical specifications	
<b>Electrical isolation</b>	
• Between 1L+ and 2L+	Yes
• Between 1L+, channels and all other circuit elements	No
• Between channels	No
• Between Ethernet and all other circuit elements	Yes
<sup>1</sup> "No temperature compensation" is always run when using the measuring type $\pm 80$ mV regardless of the configured temperature compensation. <sup>2</sup> With 3-wire resistance measurement (and thermal resistor) the measuring resistances and the line resistances are updated in alternating cycles. Rapid changes in the measuring resistance therefore impair the accuracy. <sup>3</sup> For thermocouples, the information refers to the temperature range from -100 °C to nominal value	

**Note**

The accuracy information is valid for static thermal states and changes in ambient temperature  $< 1$  K/h.

The I/O device achieves the highest accuracy with the 4-wire connection system (see technical specifications above).

Although the 3-wire connection system compensates for the missing wire, the accuracy is impaired. With the 2-wire connection system, the line resistances considerably impair the accuracy.

In the last two cases this impairment is not determinable.

**Note**

With the 3-wire connection system, the compensation of the missing cable is only ensured if all three cores in the cable have the same length and cross-section.

**See also**

Response times for analog input device and output device (Page 273)

## 10.1.2 8 AI RTD/TC 8×M12 I/O device

### Article number

6ES7144-6KD50-0AB0

### Properties

The electronic module 8 AI RTD/TC 8×M12 has the properties listed below:

- 8 freely parameterizable inputs:
  - Resistance (2-/3-/4-wire transmitter)
  - Thermoresistor (2-/3-/4-conductor connection system)
  - Thermocouple or  $\pm 80$  mV
- Input ranges:
  - Voltage measurement:  $\pm 80$  mV; resolution 15 bit + sign
  - Resistance measurement: 150  $\Omega$ , 300  $\Omega$ , 600  $\Omega$ , 3000  $\Omega$ ; resolution 15 bits
  - Resistance thermometer: Pt100, Ni100, Ni120, Pt200, Ni200, Pt500, Ni500, Pt1000, Ni1000; resolution 15 bits + sign
  - Thermocouple elements: E, J, K, N; resolution 15 bits + sign
- Dimensions 60 x 175 mm
- Diagnostics
  - "No 1L+" supply voltage
  - "Wire break"
  - "Underflow"
  - "Overflow"
- Permitted common-mode voltage AC 10V<sub>PP</sub>
- Prioritized startup
- Media redundancy

---

#### Note

##### During startup

As long as no parameters are assigned for the I/O device, the I/O device supplies the process values 7FFF<sub>H</sub>.

---

## Pin assignment

The tables below show the pin assignment for the 8 AI RTD/TC 8xM12 electronic module.

Table 10- 4 Pin assignment for RTD for the 8 AI RTD/TC 8xM12 electronic module

Pin	Assignment for RTD								View of socket (front view)
	Socket X1 (Channel 0)	Socket X2 (Channel 4)	Socket X3 (Channel 1)	Socket X4 (Channel 5)	Socket X5 (Channel 2)	Socket X6 (Channel 6)	Socket X7 (Channel 3)	Socket X8 (Channel 7)	
<b>4-conductor</b>									
1	Constant current line								
	Ic0+	Ic4+	Ic1+	Ic5+	Ic2+	Ic6+	Ic3+	Ic7+	
2	Measurement cable								
	M0+	M4+	M1+	M5+	M2+	M6+	M3+	M7+	
3	Constant current line								
	Ic0-	Ic4-	Ic1-	Ic5-	Ic2-	Ic6-	Ic3-	Ic7-	
4	Measurement cable								
	M0-	M4-	M1-	M5-	M2-	M6-	M3-	M7-	
5	Functional earth FE								
<b>3-conductor</b>									
1	Constant current line								
	Ic0+	Ic4+	Ic1+	Ic5+	Ic2+	Ic6+	Ic3+	Ic7+	
2	Measurement cable								
	M0+	M4+	M1+	M5+	M2+	M6+	M3+	M7+	
3	Constant current line and measurement cable								
	Ic0-, M0-	Ic4-, M4-	Ic1-, M1-	Ic5-, M5-	Ic2-, M2-	Ic6-, M6-	Ic3-, M3-	Ic7-, M7-	
4	Not used								
5	Functional earth FE								
<b>2-conductor</b>									
1	Constant current line and measurement cable								
	Ic0+, M0+	Ic4+, M4+	Ic1+, M1+	Ic5+, M5+	Ic2+, M2+	Ic6+, M6+	Ic3+, M3+	Ic7+, M7+	
2	Not used								
3	Constant current line and measurement cable								
	Ic0-, M0-	Ic4-, M4-	Ic1-, M1-	Ic5-, M5-	Ic2-, M2-	Ic6-, M6-	Ic3-, M3-	Ic7-, M7-	
4	Not used								
5	Functional earth FE								

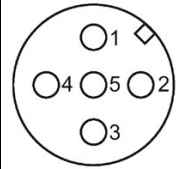

10.1 I/O device analog input

Table 10- 5 Pin assignment for thermocouples with 8 AI RTD/TC 8xM12 electronic module

Pin	Assignment for thermocouples and $\pm 80$ mV								View of socket (front view)
	Socket X1 (Channel 0)	Socket X2 (Channel 4)	Socket X3 (Channel 1)	Socket X4 (Channel 5)	Socket X5 (Channel 2)	Socket X6 (Channel 6)	Socket X7 (Channel 3)	Socket X8 (Channel 7)	
1	Not used								
2	Input signal								
	M <sub>0+</sub>	M <sub>4+</sub>	M <sub>1+</sub>	M <sub>5+</sub>	M <sub>2+</sub>	M <sub>6+</sub>	M <sub>3+</sub>	M <sub>7+</sub>	
3	Not used								
4	Input signal								
	M <sub>0-</sub>	M <sub>4-</sub>	M <sub>1-</sub>	M <sub>5-</sub>	M <sub>2-</sub>	M <sub>6-</sub>	M <sub>3-</sub>	M <sub>7-</sub>	
5	Functional earth FE								

**Block diagram**

The figure below shows the block diagram of the 8 AI RTD/TC 8xM12 electronic module.

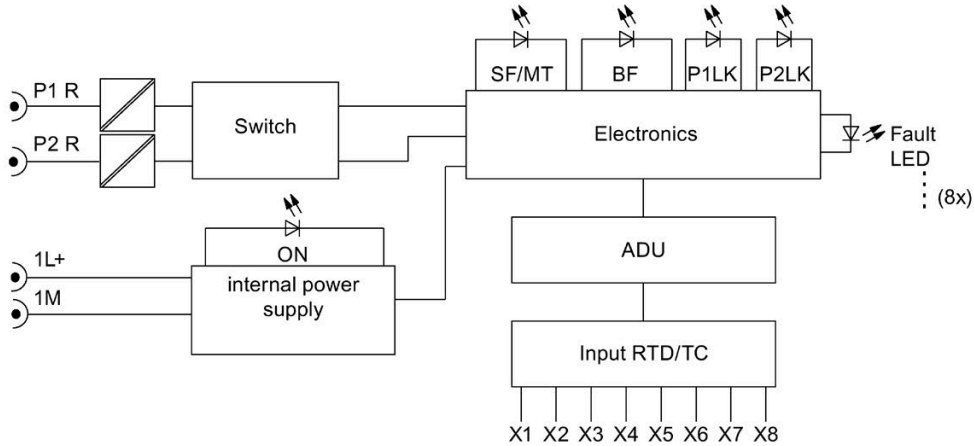

Figure 10-2 Block diagram 8 AI RTD/TC 8xM12

## Technical specifications

Technical specifications	
<b>Dimensions and weight</b>	
Dimensions W x H x D (mm)	60 x 175 x 49
Weight	Approx. 930 g
<b>Module-specific data</b>	
Transmission rate	100 Mbps full duplex
Transmission mode	100 BASE-TX
Autonegotiation	Yes
Bus protocol	PROFINET IO <ul style="list-style-type: none"> <li>• IRT with the option "high flexibility"</li> <li>• IRT with the option "high performance"</li> </ul>
Supported Ethernet services	PROFINET IO (Device) <ul style="list-style-type: none"> <li>• ping</li> <li>• arp</li> <li>• LLDP</li> <li>• Network diagnostics (SNMP)</li> <li>• DCP</li> <li>• Prioritized startup</li> <li>• Media redundancy</li> </ul>
<b>PROFINET interface</b>	
• Connection socket	2 x M12 d-coded
• Switch function	Yes, internal
• Auto-crossover	Yes; if autonegotiation is enabled
Manufacturer ID (Vendor ID)	002A <sub>H</sub>
Device ID (DeviceID)	0306 <sub>H</sub>
<b>Voltages and currents</b>	
Supply voltage 1L+	DC 24 V
Reverse polarity protection	Yes; against destruction
• Infeed current 1L+	Max. 4 A
Supply voltage 2L+	DC 24 V
• Infeed current 2L+	Max. 4 A
<b>Current consumption</b>	
• From supply voltage 1L+	Typ. 110 mA
• From supply voltage 2L+	0 mA
Power loss of the device	Typ. 2.8 W, without sensor current
<b>Analog inputs</b>	
Number of inputs	8, for RTD or thermocouple
Cable length, shielded	Max. 30 m



<b>Technical specifications</b>	
<b>Sensor selection data</b>	
Input ranges (Rated value)/input resistance or input voltage	
• Voltage	±80 mV
• Resistance	150 Ω/10 MΩ 300 Ω/10 MΩ 600 Ω/10 MΩ 3000 Ω/10 MΩ
• Thermoresistor	Pt100/10 MΩ Pt200/10 MΩ Pt500/10 MΩ Pt1000/10 MΩ Ni100/10 MΩ Ni120/10 MΩ Ni200/10 MΩ Ni500/10 MΩ Ni1000/10 MΩ
• Thermocouple	Types N, E, J, K
Permitted input voltage for voltage input (destruction limit)	28.8 V continuous, 35 V for max. duration of 500 ms
Connection of sensors for RTD	Yes (with 2-/3-/4-conductor connection)
Connection of sensors for thermocouples	Yes
Temperature compensation <sup>1</sup>	
• None	Yes, parameterizable
• Internal	Yes, parameterizable
• RTD (0)	Yes, parameterizable
• Dynamic reference temperature	Yes, parameterizable
• Fixed reference temperature	Yes, parameterizable
Technical unit for temperature measurement	°C, °F, K
<b>Formation of analog values</b>	
Measuring principle	Integrating
Integration time and conversion time/resolution (per channel)	
• Integration time parameterizable	Yes
• Interference frequency suppression in Hz	500/60/50/10
• Integration time in ms	2.0/16.667/20/100
• Conversion time in ms (per channel) <sup>2</sup>	4/19/22/102
• Resolution for RTD (including overrange)	150 Ω, 300 Ω, 600 Ω, 3000 Ω/15 bits Pt100, Pt200, Pt500, Pt1000, Ni100, Ni120, Ni200, Ni500, Ni1000/15 bits + sign
• Resolution for thermocouples (including overrange)	Types N, E, J, K/15 bits + sign

<b>Technical specifications</b>					
Measured value smoothing		Yes, parameterizable in 4 levels			
	<b>Level</b> None Weak Medium Strong	<b>Time constant</b> 1 x cycle time 4 x cycle time 16 x cycle time 64 x cycle time			
<b>Interference suppression, error limits</b>					
Interference suppression for $f = n \times (f_1 \pm 0.5\%)$ , ( $f_1 =$ interference frequency)		46 dB			
<ul style="list-style-type: none"> <li>Common-mode interference (interference voltage &lt; 5 V)</li> </ul>		70 dB			
<ul style="list-style-type: none"> <li>Series-mode interference (peak value of interference &lt; Rated value of input range)</li> </ul>		46 dB			
Crosstalk between inputs		< -85 dB			
Operational limit (across temperature range, relative to input range)		Ambient temperature			
		positive	negative (0 °C to -25 °C)	negative (-25 °C to -40 °C)	
		R, RTD	0.1%	0.15%	0.3%
		TC	0.2%	0.25%	0.4%
Basic error limit (operational limit at 25 °C, relative to input range) <sup>3</sup>		R, RTD	0.05%		
		TC	0.1%		
Temperature error (relative to input range)		Ambient temperature			
		positive	negative		
		R, RTD	0.0005%/K	0.001%/K	
		TC	0.0035%/K	0.007%/K	
Linearity error (relative to input range)		±0.01%			
Repeat accuracy (in steady-state condition at 25°C, relative to input range)		±0.008%			
Operational limits (relative to internal temperature sensor)		±3 °C			
Basic error limits (relative to internal temperature sensor)		±2 °C			
<b>Status, interrupts, diagnostics</b>					
Interrupts		Yes			
Diagnostics functions					
<ul style="list-style-type: none"> <li>Group error/maintenance</li> </ul>		Red/yellow "SF/MT" LED			
<ul style="list-style-type: none"> <li>Bus monitoring PROFINET IO</li> </ul>		Red "BF" LED			
<ul style="list-style-type: none"> <li>Monitoring of supply voltage 1L+</li> </ul>		Green "ON" LED			
<ul style="list-style-type: none"> <li>Existing connection to bus</li> </ul>		Green "P1 LK" and "P2 LK" LED; LED for PROFINET IO infeed and loop-through			
<ul style="list-style-type: none"> <li>Analog input error</li> </ul>		Red LED			
<ul style="list-style-type: none"> <li>Diagnostic information can be read</li> </ul>		Yes			

<b>Technical specifications</b>	
Monitoring for	
• Wire break	Resistors and thermoresistors
• Underflow and overflow	Yes
• Supply voltage 1L+	Yes
<b>Insulation</b>	
Insulation test voltage	
• Ethernet interface	1500 V <sub>rms</sub> (IEEE802.3, Type Test)
• All other circuit elements	707 V DC (type test)
<b>Standards, approvals, certificates</b>	
Suitable for applications according to AMS 2750	Yes; Declaration of Conformity, see online support entry 109757262
Suitable for applications according to CQI-9	Yes; based on AMS 2750 E
<b>Electrical isolation</b>	
• Between 1L+ and 2L+	Yes
• Between 1L+, channels and all other circuit elements	No
• Between channels	No
• Between Ethernet and all other circuit elements	Yes
<sup>1</sup> "No temperature compensation" is always run when using the measuring type $\pm 80$ mV regardless of the configured temperature compensation. <sup>2</sup> With 3-wire resistance measurement (and thermal resistor) the measuring resistances and the line resistances are updated in alternating cycles. Rapid changes in the measuring resistance therefore impair the accuracy. <sup>3</sup> For thermocouples, the information refers to the temperature range from -100 °C to nominal value.	

**Note**

The accuracy information is valid for static thermal states and changes in ambient temperature  $< 1$  K/h.

The I/O device achieves the highest accuracy with the 4-wire connection system (see technical specifications above).

Although the 3-wire connection system compensates for the missing wire, the accuracy is impaired. With the 2-wire connection system, the line resistances considerably impair the accuracy.

In the last two cases this impairment is not determinable.

**Note**

With the 3-wire connection system, the compensation of the missing cable is only ensured if all three cores in the cable have the same length and cross-section.

### 10.1.3 Parameter overview analog input

#### Parameters for analog input 8 AI 4 U/I + 4 RTD/TC 8xM12 (6ES7144-6KD00-0AB0)

Parameters	Range of values	Default setting	Range of effectiveness
Group diagnostics	<ul style="list-style-type: none"> <li>Disable</li> <li>Enable</li> </ul>	Disable	Device
Diagnostics, missing 1L+	<ul style="list-style-type: none"> <li>Disable</li> <li>Enable</li> </ul>	Disable	Device
Diagnostics, sensor supply short-circuit	<ul style="list-style-type: none"> <li>Disable</li> <li>Enable</li> </ul>	Disable	Device
Interference frequency suppression	<ul style="list-style-type: none"> <li>Off (Fast Mode)</li> <li>60 Hz</li> <li>50 Hz</li> <li>10 Hz</li> </ul>	50 Hz	Device
Temperature unit	<ul style="list-style-type: none"> <li>Celsius</li> <li>Fahrenheit</li> <li>Kelvin</li> </ul>	Celsius	Channel groups 4 to 7
Reference temperature for TC	<ul style="list-style-type: none"> <li>-145.0 to 155.0 (Celsius)</li> <li>-229.0 to 311.0 (Fahrenheit)</li> <li>128.2 to 428.2 (Kelvin)</li> </ul>	0.0	Device
Measurement type, channels 0 to 3	<ul style="list-style-type: none"> <li>Disabled</li> <li>Voltage</li> <li>Current (4-wire transducer)</li> <li>Current (2-wire transducer)</li> </ul>	Voltage	Channel
Measurement type, channels 4 to 7	<ul style="list-style-type: none"> <li>Disabled</li> <li>Resistance (4-wire connection)</li> <li>Resistance (3-wire connection)</li> <li>Resistance (2-wire connection)</li> <li>Thermoresistor (linear, 4-conductor connection)</li> <li>Thermoresistor (linear, 3-conductor connection)</li> <li>Thermoresistor (linear, 2-conductor connection)</li> <li>Thermocouple elements</li> <li>Voltage +/-80 mV</li> </ul>	Thermoresistor Pt100 (4-conductor connection)	Channel

Parameters	Range of values	Default setting	Range of effectiveness
Measurement range, channels 0 to 3	<ul style="list-style-type: none"> <li>• 1 to 5 V</li> <li>• 0 to 10 V</li> <li>• +/-10 V</li> <li>• 0 to 20 mA</li> <li>• 4 to 20 mA</li> <li>• ±20 mA</li> </ul>	±10 V	Channel
Measuring range, channels 4 to 7	<ul style="list-style-type: none"> <li>• +/-80 mV</li> <li>• 150 Ω</li> <li>• 300 Ω</li> <li>• 600 Ω</li> <li>• 3000 Ω</li> <li>• Pt100 Climatic range</li> <li>• Pt100 Standard range</li> <li>• Pt200 Climatic range</li> <li>• Pt200 Standard range</li> <li>• Pt500 Climatic range</li> <li>• Pt500 Standard range</li> <li>• Pt1000 Climatic range</li> <li>• Pt1000 Standard range</li> <li>• Ni100 Climatic range</li> <li>• Ni100 Standard range</li> <li>• Ni120 Climatic range</li> <li>• Ni120 Standard range</li> <li>• Ni200 Climatic range</li> <li>• Ni200 Standard range</li> <li>• Ni500 Climatic range</li> <li>• Ni500 Standard range</li> <li>• Ni1000 Climatic range</li> <li>• Ni1000 Standard range</li> <li>• TC_EL Typ_N_[NiCrSi_NiSi]</li> <li>• TC_EL Typ_E_[NiCr_CuNi]</li> <li>• TC_EL Typ_J_[Fe_CuNi]</li> <li>• TC_EL Typ_K_[NiCr_Ni]</li> </ul>	Pt100 Standard range	Channel
Reference junction for thermoresistor (TC)	<ul style="list-style-type: none"> <li>• Internal</li> <li>• External</li> </ul>	Internal	Channel

Parameters	Range of values	Default setting	Range of effectiveness
Temperature coefficient	<ul style="list-style-type: none"> <li>• Pt 0.003916</li> <li>• Pt 0.003902</li> <li>• Pt 0.00392</li> <li>• Pt 0.003851<sup>1</sup></li> <li>• Ni 0.00618</li> <li>• Ni 0.00672</li> <li>• Ni 0.005000</li> </ul>	Pt 0.003851 <sup>1</sup>	Channel
Smoothing	<ul style="list-style-type: none"> <li>• None</li> <li>• Weak</li> <li>• Medium</li> <li>• Strong</li> </ul>	None	Channel
Diagnostics, wire break	<ul style="list-style-type: none"> <li>• Disable</li> <li>• Enable</li> </ul>	Disable	Channel
Diagnostics, underflow	<ul style="list-style-type: none"> <li>• Disable</li> <li>• Enable</li> </ul>	Disable	Channel
Diagnostics, overflow	<ul style="list-style-type: none"> <li>• Disable</li> <li>• Enable</li> </ul>	Disable	Channel
<sup>1</sup> This value can also be shown as $\alpha = 0.00385055$ in the parameter assignment.			

**Parameters for analog input 8 AI RTD/TC 8xM12 (6ES7144-6KD50-0AB0)**

Parameters	Range of values	Default setting	Range of effectiveness
Group diagnostics	<ul style="list-style-type: none"> <li>• Disable</li> <li>• Enable</li> </ul>	Disable	Device
Diagnostics, missing 1L+	<ul style="list-style-type: none"> <li>• Disable</li> <li>• Enable</li> </ul>	Disable	Device
Interference frequency suppression	<ul style="list-style-type: none"> <li>• Off (Fast Mode)</li> <li>• 60 Hz</li> <li>• 50 Hz</li> <li>• 10 Hz</li> </ul>	50 Hz	Device
Temperature unit	<ul style="list-style-type: none"> <li>• Celsius</li> <li>• Fahrenheit</li> <li>• Kelvin</li> </ul>	Celsius	Device
Reference temperature for TC	<ul style="list-style-type: none"> <li>• -145.0 to 155.0 (Celsius)</li> <li>• -229.0 to 311.0 (Fahrenheit)</li> <li>• 128.2 to 428.2 (Kelvin)</li> </ul>	0.0	Device
Measurement type, channels 0 to 7	<ul style="list-style-type: none"> <li>• Disabled</li> <li>• Voltage +/-80 mV</li> <li>• Resistance (4-wire connection)</li> <li>• Resistance (3-wire connection)</li> <li>• Resistance (2-wire connection)</li> <li>• Thermoresistor (linear, 4-conductor connection)</li> <li>• Thermoresistor (linear, 3-conductor connection)</li> <li>• Thermoresistor (linear, 2-conductor connection)</li> <li>• Thermocouple elements</li> </ul>	Thermoresistor Pt100 (4-conductor connection)	Channel

## 10.1 I/O device analog input

Parameters	Range of values	Default setting	Range of effectiveness
Measuring range, channels 0 to 7	<ul style="list-style-type: none"> <li>• +/-80 mV</li> <li>• 150 Ω</li> <li>• 300 Ω</li> <li>• 600 Ω</li> <li>• 3000 Ω</li> <li>• Pt100 Climatic range</li> <li>• Pt100 Standard range</li> <li>• Pt200 Climatic range</li> <li>• Pt200 Standard range</li> <li>• Pt500 Climatic range</li> <li>• Pt500 Standard range</li> <li>• Pt1000 Climatic range</li> <li>• Pt1000 Standard range</li> <li>• Ni100 Climatic range</li> <li>• Ni100 Standard range</li> <li>• Ni120 Climatic range</li> <li>• Ni120 Standard range</li> <li>• Ni200 Climatic range</li> <li>• Ni200 Standard range</li> <li>• Ni500 Climatic range</li> <li>• Ni500 Standard range</li> <li>• Ni1000 Climatic range</li> <li>• Ni1000 Standard range</li> <li>• TC_EL Typ_N_[NiCrSi_NiSi]</li> <li>• TC_EL Typ_E_[NiCr_CuNi]</li> <li>• TC_EL Typ_J_[Fe_CuNi]</li> <li>• TC_EL Typ_K_[NiCr_Ni]</li> </ul>	Pt100 Standard range	Channel
Reference junction for thermoresistor (TC)	<ul style="list-style-type: none"> <li>• None</li> <li>• Internal</li> <li>• RTD (0)</li> <li>• Dynamic Ref. Temp.</li> <li>• Fixed Ref. Temp.</li> </ul>	Internal	Channel
Temperature coefficient	<ul style="list-style-type: none"> <li>• Pt 0.003916</li> <li>• Pt 0.003902</li> <li>• Pt 0.00392</li> <li>• Pt 0.003851<sup>1</sup></li> <li>• Ni 0.00618</li> <li>• Ni 0.00672</li> <li>• Ni 0.005000</li> </ul>	Pt 0.003851 <sup>1</sup>	Channel



Parameters	Range of values	Default setting	Range of effectiveness
Smoothing	<ul style="list-style-type: none"> <li>• None</li> <li>• Weak</li> <li>• Medium</li> <li>• Strong</li> </ul>	None	Channel
Diagnostics, wire break	<ul style="list-style-type: none"> <li>• Disable</li> <li>• Enable</li> </ul>	Disable	Channel
Diagnostics, underflow	<ul style="list-style-type: none"> <li>• Disable</li> <li>• Enable</li> </ul>	Disable	Channel
Diagnostics, overflow	<ul style="list-style-type: none"> <li>• Disable</li> <li>• Enable</li> </ul>	Disable	Channel

<sup>1</sup>This value can also be shown as  $\alpha = 0.00385055$  in the parameter assignment.

### Measuring type with 8 AI RTD

The following table lists the temperature coefficients and measuring ranges you can assign for each measurement type:

Measurement type	Temperature coefficient	Measuring range
Thermoresistor 4-conductor Thermoresistor 3-conductor Thermoresistor 2-conductor	Pt 0.003851 <sup>1, 2)</sup> Pt 0.003916/ Pt 0.003902/ Pt 0.003920	Pt100 Climatic range / Pt100 Standard range / Pt200 Climatic range / Pt200 Standard range / Pt500 Climatic range / Pt500 Standard range / Pt1000 Climatic range / Pt1000 Standard range
	Ni 0.006180 <sup>1)</sup> Ni 0.006720/ Ni 0.005 <sup>3)</sup>	Ni100 Climatic range / Ni100 Standard range / Ni120 Climatic range / Ni120 Standard range / Ni200 Climatic range / Ni200 Standard range / Ni500 Climatic range / Ni500 Standard range / Ni1000 Climatic range / Ni1000 Standard range

<sup>1</sup> The default settings for the temperature coefficients apply according to the standard EN60751.

<sup>2</sup>This value can also be shown as  $\alpha = 0.00385055$  in the parameter assignment.

<sup>3</sup> The thermoresistor LG-Ni1000 corresponds to the thermoresistor Ni1000 with the temperature coefficient 0.005

#### Note

For a thermoresistor, the climatic type is only possible with temperature units Celsius (°C) and Fahrenheit (°F).

## 10.1.4 Parameter description analog input

### Group diagnostics

You can generally enable and disable the diagnostics function of the device with this parameter.

The "Fault" and "Parameter assignment error" diagnostics functions are always independent of the group diagnostics.

### Diagnostics: Missing 1L+

If you enable this parameter, the check for missing supply voltage is enabled.

### Diagnostics: Short-circuit sensor supply

If you enable this parameter, a diagnostics event is generated if a short-circuit of the sensor supply to ground is detected and the channel is enabled. The sensor supply is monitored for connectors X1, X3, X5, and X7. No differentiation is made as to the connector where the sensor short-circuit occurred.

### Interference frequency suppression

With this parameter, you set the integration time of the device, based on the selected interference frequency. Select the frequency of the supply voltage used. Interference frequency suppression "Off (Fast Mode)" means 500 Hz, which corresponds to an integration time of 2 ms for a measurement channel.

### Temperature unit

This parameter is used to select the unit in which the temperature is detected.

### Reference temperature for TC

The reference temperature applies to all channels at which "Fix Ref. Temp." was selected at "Reference junction". Information about the value range of the reference temperature is available in the table Reference temperature for TC (Page 203).

### Measurement type (channel-wise)

Click the field to have the available measurement types displayed and select them.

Possible measurement types:

- Voltage  $\pm 80$  mV
- Resistor (4-wire connection)
- Resistor (3-wire connection)
- Resistor (2-wire connection)
- Thermal resistor (linear, 4-wire connection)
- Thermal resistor (linear, 3-wire connection)
- Thermal resistor (linear, 2-wire connection)
- Thermocouple

This parameter is used to set the measuring method, for example voltage. For any unused channels, you must select the **disabled** setting. For a disabled channel, the conversion time and integration time of the channel = 0 s, and the overall cycle time of the device is reduced.

### Measuring range

With this parameter, you set the measuring range of the selected measurement type.

### Temperature coefficient (for RTD, thermoresistor)

The correction factor for the temperature coefficient ( $\alpha$ -value) specifies the extent to which the resistance of a certain material changes when the temperature is raised by 1 °C.

The  $\alpha$ -values conform to EN 60751, GOST 6651, JIS C 1604, and ASTM E-1137.

The temperature coefficient depends on the chemical composition of the material.

## Smoothing

Smoothing of the analog values produces a stable analog signal for further processing. The smoothing of analog values is useful when handling wanted signals (measured values) with a slow rate of change, for example, temperature measurements.

The measured values are smoothed by digital filtering. To achieve smoothing, the device generates a mean value from a specified number of converted (digitized) analog values.

You assign a maximum of four levels for the smoothing (none, weak, medium, strong). The level determines the number of module cycles, from which the mean value is generated.

The stronger the smoothing, the more precisely the smoothed analog value reaches the setpoint value. The time interval until the smoothed analog value is applied after a signal change is also prolonged.

The figure below shows the number of cycles a module requires to apply the smoothed analog value at almost 100% after a step response, based on the smoothing function settings. The figure applies to all signal changes at the analog input. The smoothing value defines the number of cycles a module requires to reach 63% of the end value of the changed signal.

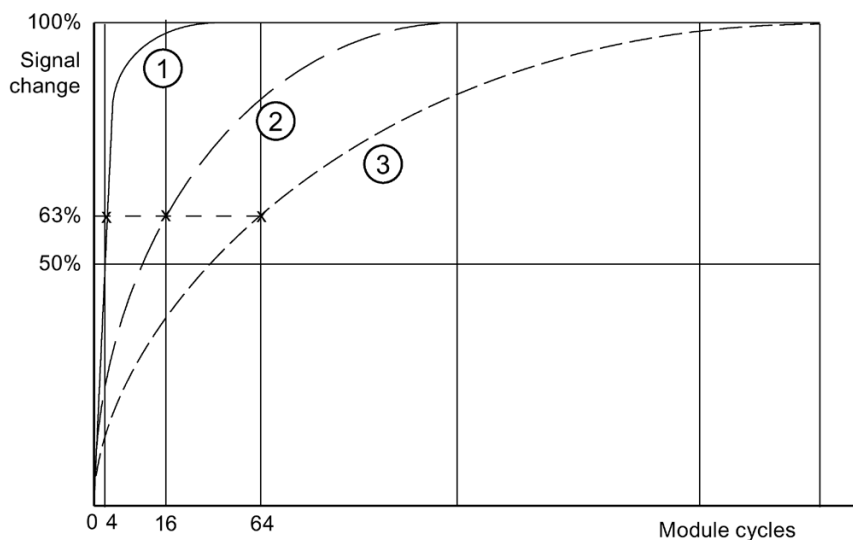

- ① Smoothing, weak
- ② Smoothing, medium
- ③ Smoothing, strong

## Diagnostics: Wire break

When this parameter is enabled, the **Wire break** diagnostics event is generated when a wire break is detected.

Observe the rules outlined below to handle a wire break in the 1 V to 5 V and 4 mA to 20 mA measuring ranges:

Parameters	Event	Measured value	Explanation
Enable wire break <sup>1</sup>	Wire break	7FFF <sub>H</sub>	Diagnostics, <b>wire break</b>
Wire break disabled <sup>1</sup> Underflow enabled	Wire break	8000 <sub>H</sub>	Measured value after leaving the under-shoot range Diagnostic message <b>Lower limit value undershot</b>
Wire break disabled <sup>1</sup> Underflow disabled	Wire break	8000 <sub>H</sub>	Measured value after leaving the under-shoot range
<sup>1</sup> Measuring range limits for wire break detection and measuring range undershoot detection: <ul style="list-style-type: none"> <li>• 1 V to 5 V: At 0.296 V</li> <li>• 4 mA to 20 mA: At 1.185 mA</li> </ul>			

## Diagnostics at 8AI RTD/TC

Take the following diagnostics into account:

Diagnostics, wire break	Diagnostics, overflow	Diagnostics, underflow	Event	Process data	Diagnostic message per channel:
Activated	Deactivated	Deactivated	Wire break	0x7FFF	Wire break
Deactivated	Deactivated	Activated	Wire break	0x8000	Low limit violated
Deactivated	Activated	Deactivated	Wire break	0x7FFF	High limit violated
Deactivated	Activated	Activated	Wire break	0x8000	Low limit violated
Deactivated	Deactivated	Deactivated	Wire break	0x7FFF	

## Diagnostics: Underflow

If the measured value reaches the underflow range and you enable this parameter, the **Underflow** diagnostics event is generated.

## Diagnostics: Overflow

If the measured value reaches the overflow range and you enable this parameter, the **Overflow** diagnostics event is generated.

## Reference junction for thermoresistor (TC)

A difference in temperature between the measuring point and the free ends of the thermocouple (terminal point) generates a voltage between the free ends, namely the thermoelectric voltage. The value of this thermoelectric voltage is determined by the temperature difference between the measuring point and the free ends, and by the type of material combination of the thermocouple. Since a thermocouple always measures a temperature difference, the free ends at the reference junction must be maintained at a known temperature in order to determine the temperature of the measuring point.

In the case of the I/O device 8 AI 4 U/I + 4 RTD/TC 8×M12 and 8 AI RTD/TC 8×M12, the following compensation settings are possible:

- No / external compensation: The reference junction temperature is measured outside the module, e.g., via a compensation slot.

With this compensation type, the reference junction temperature of the thermocouples is measured outside the two I/O devices. For this purpose you can, for example, connect a compensation slot to the thermocouple.

With this compensation type, the temperature of the reference junction is specified at 0 °C .

The temperature of 0 °C is reached when a compensation slot is used. One compensation slot is required per thermocouple.

- Internal: The temperature of the measuring point is measured in the housing of the I/O device.

With this type of compensation the reference junction temperature is determined with an internal temperature sensor. One temperature sensor is integrated into each I/O device.

The reference junction temperature is detected by an internal temperature sensor.

The same reference junction temperature is assigned to all the channels of the I/O devices that you selected for this type of compensation.

With the I/O device 8 AI RTD/TC 8xM12, the following compensation settings are also possible :

- RTD (0): The reference junction temperature is determined by means of a thermal resistor (Pt1000).

With this compensation the reference junction temperature is determined by measuring the resistance value of a Pt1000 at the terminal point of the M12 compensation connector. The resistance measurement may only be carried out on the round socket X1 (Channel 0).

The reference junction temperature is determined by the resistance value Pt1000.

The same reference junction temperature is assigned to all the channels of the I/O device 8 AI RTD/TC 8xM12 that you selected for this type of compensation.

The cycle time increases by 1 x the conversion time.

If the compensation RTD (0) is selected on a channel of the I/O device 8 AI RTD/TC 8xM12, the measurement type for Channel 0 (X1) is limited; that is, only the measurement types "Thermocouple" or " $\pm 80$  mV" are possible.

A wire break at Pt1000 cannot be detected and is reported with the diagnosis "Reference channel error".

- The M12 compensation connector is provided for the temperature compensation "RTD (0)" (prerequisite: "Reference junction" parameter set to "RTD (0)". For all other temperature compensations, no M12 compensation connector is required.

The M12 compensation connector has an integrated resistance thermometer Pt1000 (with  $\alpha = 0.003851$ ) for compensating the reference junction temperature of the thermocouples. The  $\alpha$  value conforms to the standards EN 60751, GOST 6651, JIS C 1604 and ASTM E-1137.

The M12 compensation connector is delivered unassembled. You can connect a thermocouple by using terminals 2 and 4 of the M12 compensation connector.

The M12 compensation connector is bolted to the round socket X1 on the connection module CM IO 4 x M12 (torque: 1.5 Nm). The procedure is identical to the M12 connector (see section Mounting (Page 20)).

---

#### Note

The M12 compensation connector is only designed for the electronic module 8 AI RTD/TC 8xM12. Operation without a cable is not permitted in order to comply with degree of protection IP67.

---

- **Dynamic Ref. Temp.:** The reference junction temperature is measured via a module on a different station.

With this type of compensation the reference junction temperature (compensation voltage) is measured by means of an external module on another station.

The reference junction temperature is transferred from the CPU to the I/O device 8 AI RTD/TC 8xM12 by means of the data record DS2 using the SFB 53.

An separate reference junction temperature can be assigned by means of the the user program to each channel for which you select this type of compensation.

- **Fixed Ref. Temp.:** The reference temperature is specified permanently.

With this type of compensation, the reference junction temperature is stored as a parameter.

The reference junction temperature is specified in the parameter "Reference temperature for TC".

The possible value range is listed in the table Reference temperature for TC (Page 203).

The parameterized reference junction temperature is valid for all the channels of the I/O device for which you have selected this type of compensation.

## 10.1.5 Analog value representation for measuring ranges with SIMATIC S7

### Representation of analog values

With the same nominal range, the digitized analog value is the same for input and output values. Analog values are represented in two's complement.

The following table shows the representation of analog values of the analog input.

Table 10- 6 Representation of analog values (SIMATIC S7 format)

Resolution	Analog value															
Bit number	15	14	13	12	11	10	9	8	7	6	5	4	3	2	1	0
Significance of the bits	Sign	$2^{14}$	$2^{13}$	$2^{12}$	$2^{11}$	$2^{10}$	$2^9$	$2^8$	$2^7$	$2^6$	$2^5$	$2^4$	$2^3$	$2^2$	$2^1$	$2^0$

### Sign

The sign (S) of the analog value is always in bit number 15:

- "0" → +
- "1" → -



## 10.1.6 Measuring ranges of the analog input device in S7 format

### Voltage measuring ranges: Measuring range 1 to 5 V

Measuring range 1 to 5 V	Units		Range
	Decimal	Hexadecimal	
> 5.704 V	32767	7FFF <sub>H</sub>	Overflow
5.704 V	32511	7EFF <sub>H</sub>	Overrange
	27649	6C01 <sub>H</sub>	
5 V	27648	6C00 <sub>H</sub>	Nominal range
4 V	20736	5100 <sub>H</sub>	
1 V + 144.7 μV	1	0001 <sub>H</sub>	
1 V	0	0000 <sub>H</sub>	
	-1	FFFF <sub>H</sub>	Underrange
0.296 V	-4864	ED00 <sub>H</sub>	Wire break
< 0.296 V	32767	7FFF <sub>H</sub>	
	- 32768	8000 <sub>H</sub>	Underflow

### Voltage measuring ranges: Measuring range 0 to 10 V

Measuring range 0 to 10 V	Units		Range
	Decimal	Hexadecimal	
> 11.759 V	32767	7FFF <sub>H</sub>	Overflow
11.759 V	32511	7EFF <sub>H</sub>	Overrange
	27649	6C01 <sub>H</sub>	
10 V	27648	6C00 <sub>H</sub>	Nominal range
7.5 V	20736	5100 <sub>H</sub>	
0 V + 361.7 μV	1	0001 <sub>H</sub>	
0 V	0	0000 <sub>H</sub>	
	-1	FFFF <sub>H</sub>	Underrange
-1.759 V	-4864	ED00 <sub>H</sub>	Underflow
< -1.759 V	- 32768	8000 <sub>H</sub>	

Measuring ranges for voltage:  $\pm 10$  mV

Measuring range $\pm 10$ V	Units		Range
	Decimal	Hexadecimal	
> 11.759 V	32767	7FFF <sub>H</sub>	Overflow
11.759 V	32511	7EFF <sub>H</sub>	Overrange
	27649	6C01 <sub>H</sub>	
10 V	27648	6C00 <sub>H</sub>	Nominal range
7.5 V	20736	5100 <sub>H</sub>	
361.7 $\mu$ V	1	0001 <sub>H</sub>	
0 V	0	0000 <sub>H</sub>	
	-1	FFFF <sub>H</sub>	
-7.5 V	-20736	AF00 <sub>H</sub>	
-10 V	-27648	9400 <sub>H</sub>	
	-27649	93FF <sub>H</sub>	
-11.759 V	-32512	8100 <sub>H</sub>	Underrange
< -11.759 V	-32768	8000 <sub>H</sub>	Underflow

## Current measuring range: 0 to 20 mA

Measuring range 0 to 20 mA	Units		Range
	Decimal	Hexadecimal	
> 23.52 mA	32767	7FFF <sub>H</sub>	Overflow
23.52 mA	32511	7EFF <sub>H</sub>	Overrange
	27649	6C01 <sub>H</sub>	
20 mA	27648	6C00 <sub>H</sub>	Nominal range
15 mA	20736	5100 <sub>H</sub>	
723.4 nA	1	0001 <sub>H</sub>	
0 mA	0	0000 <sub>H</sub>	
	1	FFFF <sub>H</sub>	
-3.52 mA	-4864	ED00 <sub>H</sub>	Underrange
< -3.52 mA	32768	8000 <sub>H</sub>	Underflow

**Current measuring range: 4 to 20 mA**

Measuring range 4 to 20 mA	Units		Range
	Decimal	Hexadecimal	
> 22.81 mA	32767	7FFF <sub>H</sub>	Overflow
22.81 mA	32511	7EFF <sub>H</sub>	Overrange
	27649	6C01 <sub>H</sub>	
20 mA	27648	6C00 <sub>H</sub>	Nominal range
16 mA	20736	5100 <sub>H</sub>	
4 mA + 578.7 nA	1	0001 <sub>H</sub>	
4 mA	0	0000 <sub>H</sub>	
	1	FFFF <sub>H</sub>	Underrange
1.185 mA	-4864	ED00 <sub>H</sub>	Wire break
< 1.185 mA	32767	7FFF <sub>H</sub>	
	-32768	8000 <sub>H</sub>	Underflow

**Measuring range for current: ±20 mA**

Measuring range ±20 mA	Units		Range
	Decimal	Hexadecimal	
> 23.52 mA	32767	7FFF <sub>H</sub>	Overflow
23.52 mA	32511	7EFF <sub>H</sub>	Overrange
	27649	6C01 <sub>H</sub>	
20 mA	27648	6C00 <sub>H</sub>	Nominal range
15 mA	20736	5100 <sub>H</sub>	
723.4 nA	1	0001 <sub>H</sub>	
0 mA	0	0000 <sub>H</sub>	
	-1	FFFF <sub>H</sub>	Underrange
-15 mA	-20736	AF00 <sub>H</sub>	
-20 mA	-27648	9400 <sub>H</sub>	
	-27649	93FF <sub>H</sub>	
-23.52 mA	-32512	8100 <sub>H</sub>	Underflow
< -23.52 mA	-32768	8000 <sub>H</sub>	

**Measuring range for voltage:  $\pm 80$  mV**

Measuring range $\pm 80$ mV	Units		Range
	Decimal	Hexadecimal	
> 94.1 mV	32767	7FFF <sub>H</sub>	Overflow
94.1 mV	32511	7EFF <sub>H</sub>	Overrange
	27649	6C01 <sub>H</sub>	
80 mV	27648	6C00 <sub>H</sub>	Nominal range
60 mV	20736	5100 <sub>H</sub>	
2.89 $\mu$ V	1	0001 <sub>H</sub>	
0 mV	0	0000 <sub>H</sub>	
	-1	FFFF <sub>H</sub>	
-60 mV	-20736	AF00 <sub>H</sub>	
-80 mV	-27648	9400 <sub>H</sub>	
	-27649	93FF <sub>H</sub>	Underrange
-94.1 mV	-32512	8100 <sub>H</sub>	Underflow
< -94.1 mV	-32768	8000 <sub>H</sub>	

**Measuring ranges for resistance-based sensor: 150  $\Omega$ , 300  $\Omega$ , 600  $\Omega$ , 3000  $\Omega$** 

Measuring range				Units		Range
				Decimal	Hexadecimal	
150 $\Omega$	300 $\Omega$	600 $\Omega$	3 k $\Omega$			
> 176.38 $\Omega$	> 352.77 $\Omega$	> 705.53 $\Omega$	> 3.53 k $\Omega$	32767	7FFF <sub>H</sub>	Overflow
176.38 $\Omega$	352.77 $\Omega$	705.53 $\Omega$	3.53 k $\Omega$	32511	7EFF <sub>H</sub>	Overrange
				27649	6C01 <sub>H</sub>	
150 $\Omega$	300 $\Omega$	600 $\Omega$	3 k $\Omega$	27648	6C00 <sub>H</sub>	Nominal range
112.5 $\Omega$	225 $\Omega$	450 $\Omega$	2.25 k $\Omega$	20736	5100 <sub>H</sub>	
5.43 m $\Omega$	10.85 m $\Omega$	21.70 m $\Omega$	108.05 m $\Omega$	1	0001 <sub>H</sub>	
0 $\Omega$	0 $\Omega$	0 $\Omega$	0 $\Omega$	0	0000 <sub>H</sub>	

Negative values are physically impossible

## Measuring ranges for Pt x00 standard thermal resistor

Pt x00 Standard in °C (1 digit = 0.1°C)	Units		Pt x00 Standard in °F (1 digit = 0.1°F)	Units		Pt x00 Standard in K (1 digit = 0.1 K)	Units		Range
	Decimal	Hexadec- imal		Decimal	Hexadec- imal		Decimal	Hexadec- imal	
> 1000.0	32767	7FFF <sub>H</sub>	> 1832.0	32767	7FFF <sub>H</sub>	> 1273.2	32767	7FFF <sub>H</sub>	Overflow
1000.0	10000	2710 <sub>H</sub>	1832.0	18320	4790 <sub>H</sub>	1273.2	12732	31BC <sub>H</sub>	Overrange
:	:	:	:	:	:	:	:	:	
850.1	8501	2135 <sub>H</sub>	1562.1	15621	3D05 <sub>H</sub>	1123.3	11233	2BE1 <sub>H</sub>	
850.0	8500	2134 <sub>H</sub>	1562.0	15620	3D04 <sub>H</sub>	1123.2	11232	2BE0 <sub>H</sub>	Nominal range
:	:	:	:	:	:	:	:	:	
-200.0	-2000	F830 <sub>H</sub>	-328.0	-3280	F330 <sub>H</sub>	73.2	732	2DC <sub>H</sub>	
-200.1	-2001	F82F <sub>H</sub>	-328.1	-3281	F32F <sub>H</sub>	73.1	731	2DB <sub>H</sub>	Underrange
:	:	:	:	:	:	:	:	:	
-243.0	-2430	F682 <sub>H</sub>	-405.4	-4054	F02A <sub>H</sub>	30.2	302	12E <sub>H</sub>	
< -243.0	-32768	8000 <sub>H</sub>	< -405.4	-32768	8000 <sub>H</sub>	< 30.2	32768	8000 <sub>H</sub>	Underflow

## Measuring ranges for Pt x00 climatic thermal resistor

Pt x00 Climatic in °C (1 digit = 0.01 °C)	Units		Pt x00 Climatic in °F (1 digit = 0.01 °F)	Units		Range
	Decimal	Hexadecimal		Decimal	Hexadecimal	
> 155.00	32767	7FFF <sub>H</sub>	> 311.00	32767	7FFF <sub>H</sub>	Overflow
155.00	15500	3C8C <sub>H</sub>	311.00	31100	797C <sub>H</sub>	Overrange
:	:	:	:	:	:	
130.01	13001	32C9 <sub>H</sub>	266.01	26601	67E9 <sub>H</sub>	
130.00	13000	32C8 <sub>H</sub>	266.00	26600	67E8 <sub>H</sub>	Nominal range
:	:	:	:	:	:	
-120.00	-12000	D120 <sub>H</sub>	-184.00	-18400	B820 <sub>H</sub>	
-120.01	-12001	D11F <sub>H</sub>	-184.01	-18401	B81F <sub>H</sub>	Underrange
:	:	:	:	:	:	
-145.00	-14500	C75C <sub>H</sub>	-229.00	-22900	A68C <sub>H</sub>	
< -145.00	-32768	8000 <sub>H</sub>	< -229.00	-32768	8000 <sub>H</sub>	Underflow

## Measuring ranges for Ni x00 Standard thermal resistor

Ni x00 Standard in °C (1 digit = 0.1°C)	Units		Ni x00 Standard in °F (1 digit = 0.1°F)	Units		Ni x00 Standard in K (1 digit = 0.1 K)	Units		Range
	Decimal	Hexadecimal		Decimal	Hexadecimal		Decimal	Hexadecimal	
> 295.0	32767	7FFF <sub>H</sub>	> 563.0	32767	7FFF <sub>H</sub>	> 568.2	32767	7FFF <sub>H</sub>	Overflow
295.0	2950	B86 <sub>H</sub>	563.0	5630	15FE <sub>H</sub>	568.2	5682	1632 <sub>H</sub>	Overrange
:	:	:	:	:	:	:	:	:	
250.1	2501	9C5 <sub>H</sub>	482.1	4821	12D5 <sub>H</sub>	523.3	5233	1471 <sub>H</sub>	Nominal range
250.0	2500	9C4 <sub>H</sub>	482.0	4820	12D4 <sub>H</sub>	523.2	5232	1470 <sub>H</sub>	
:	:	:	:	:	:	:	:	:	Underrange
-60.0	-600	FDA8 <sub>H</sub>	-76.0	-760	FD08 <sub>H</sub>	213.2	2132	854 <sub>H</sub>	
-60.1	-601	FDA7 <sub>H</sub>	-76.1	-761	FD07 <sub>H</sub>	213.1	2131	853 <sub>H</sub>	Underflow
:	:	:	:	:	:	:	:	:	
-105.0	-1050	FBE6 <sub>H</sub>	-157.0	-1570	F9DE <sub>H</sub>	168.2	1682	692 <sub>H</sub>	
< -105.0	-32768	8000 <sub>H</sub>	< -157.0	-32768	8000 <sub>H</sub>	< 168.2	32768	8000 <sub>H</sub>	

## Measuring ranges for Ni x00 climatic thermal resistor

Ni x00 Climatic in °C (1 digit = 0.01 °C)	Units		Ni x00 Climatic in °F (1 digit = 0.01 °F)	Units		Range
	Decimal	Hexadecimal		Decimal	Hexadecimal	
> 155.00	32767	7FFF <sub>H</sub>	> 311.00	32767	7FFF <sub>H</sub>	Overflow
155.00	15500	3C8C <sub>H</sub>	311.00	31100	797C <sub>H</sub>	Overrange
:	:	:	:	:	:	
130.01	13001	32C9 <sub>H</sub>	266.01	26601	67E9 <sub>H</sub>	Nominal range
130.00	13000	32C8 <sub>H</sub>	266.00	26600	67E8 <sub>H</sub>	
:	:	:	:	:	:	Underrange
-60.00	-6000	E890 <sub>H</sub>	-76.00	-7600	E250 <sub>H</sub>	
-60.01	-6001	E88F <sub>H</sub>	-76.01	-7601	E24F <sub>H</sub>	Underflow
:	:	:	:	:	:	
-105.00	-10500	D6FC <sub>H</sub>	-157.00	-15700	C2AC <sub>H</sub>	
< -105.00	-32768	8000 <sub>H</sub>	< -157.00	-32768	8000 <sub>H</sub>	

**Representation of analog values for thermocouple type E**

Type E in °C	Units		Type E in °F	Units		Type E in K	Units		Range
	Decimal	Hexadec- imal		Decimal	Hexadec- imal		Decimal	Hexadec- imal	
> 1200.0	32767	7FFF <sub>H</sub>	> 2192.0	32767	7FFF <sub>H</sub>	> 1473.2	32767	7FFF <sub>H</sub>	Overflow
1200.0	12000	2EE0 <sub>H</sub>	2192.0	21920	55A0 <sub>H</sub>	1473.2	14732	398C <sub>H</sub>	Overrange
:	:	:	:	:	:	:	:	:	
1000.1	10001	2711 <sub>H</sub>	1832.1	18321	4791 <sub>H</sub>	1273.3	12733	31BD <sub>H</sub>	
1000.0	10000	2710 <sub>H</sub>	1832.0	18320	4790 <sub>H</sub>	1273.2	12732	31BC <sub>H</sub>	Nominal range
:	:	:	:	:	:	:	:	:	
-270.0	-2700	F574 <sub>H</sub>	-454.0	-4540	EE44 <sub>H</sub>	3.2	32	0020 <sub>H</sub>	
< -270.0	-32768	8000 <sub>H</sub>	< -454.0	-32768	8000 <sub>H</sub>	< 3.2	-32768	8000 <sub>H</sub>	Underflow

**Measuring ranges for thermocouple Type N**

Type N in °C	Units		Type N in °F	Units		Type N in K	Units		Range
	Decimal	Hexadec- imal		Decimal	Hexadec- imal		Decimal	Hexadec- imal	
> 1550.0	32767	7FFF <sub>H</sub>	> 2822.0	32767	7FFF <sub>H</sub>	> 1823.2	32767	7FFF <sub>H</sub>	Overflow
1550.0	15500	3C8C <sub>H</sub>	2822.0	28220	6E3C <sub>H</sub>	1823.2	18232	4738 <sub>H</sub>	Overrange
:	:	:	:	:	:	:	:	:	
1300.1	13001	32C9 <sub>H</sub>	2372.1	23721	5CA9 <sub>H</sub>	1573.3	15733	3D75 <sub>H</sub>	
1300.0	13000	32C8 <sub>H</sub>	2372.0	23720	5CA8 <sub>H</sub>	1573.2	15732	3D74 <sub>H</sub>	Nominal range
:	:	:	:	:	:	:	:	:	
-270.0	-2700	F574 <sub>H</sub>	-454.0	-4540	EE44 <sub>H</sub>	3.2	32	0020 <sub>H</sub>	
< -270.0	-32768	8000 <sub>H</sub>	< -454.0	-32768	8000 <sub>H</sub>	< 3.2	-32768	8000 <sub>H</sub>	Underflow

**Representation of analog values for thermocouple type J**

Type J in °C	Units		Type J in °F	Units		Type J in K	Units		Range
	Decimal	Hexadec- imal		Decimal	Hexadec- imal		Decimal	Hexadec- imal	
> 1450.0	32767	7FFF <sub>H</sub>	> 2642.0	32767	7FFF <sub>H</sub>	> 1723.2	32767	7FFF <sub>H</sub>	Overflow
1450.0	14500	38A4 <sub>H</sub>	2642.0	26420	6734 <sub>H</sub>	1723.2	17232	4350 <sub>H</sub>	Overrange
:	:	:	:	:	:	:	:	:	
1200.1	12001	2EE1 <sub>H</sub>	2192.1	21921	55A1 <sub>H</sub>	1473.3	14733	398D <sub>H</sub>	
1200.0	12000	2EE0 <sub>H</sub>	2192.0	21920	55A0 <sub>H</sub>	1473.2	14732	398C <sub>H</sub>	Nominal range
:	:	:	:	:	:	:	:	:	
-210.0	-2100	F7CC <sub>H</sub>	-346.0	-3460	F27C <sub>H</sub>	63.2	632	0278 <sub>H</sub>	
< -210.0	-32768	<8000 <sub>H</sub>	< -346.0	-32768	8000 <sub>H</sub>	< 63.2	-32768	8000 <sub>H</sub>	Underflow

## Representation of analog values for thermocouple type K

Type K in °C	Units		Type K in °F	Units		Type K in K	Units		Range
	Decimal	Hexadec- imal		Decimal	Hexadec- imal		Decimal	Hexadec- imal	
> 1622.0	32767	7FFF <sub>H</sub>	> 2951.6	32767	7FFF <sub>H</sub>	> 1895.2	32767	7FFF <sub>H</sub>	Overflow
1622.0	16220	3F5C <sub>H</sub>	2951.6	29516	734C <sub>H</sub>	1895.2	18952	4A08 <sub>H</sub>	Overrange
:	:	:	:	:	:	:	:	:	
1372.1	13721	3599 <sub>H</sub>	2501.7	25017	61B9 <sub>H</sub>	1645.3	16453	4045 <sub>H</sub>	Nominal range
1372.0	13720	3598 <sub>H</sub>	2501.6	25016	61B8 <sub>H</sub>	1645.2	16452	4044 <sub>H</sub>	
:	:	:	:	:	:	:	:	:	
-270.0	-2700	F574 <sub>H</sub>	-454.0	-4540	EE44 <sub>H</sub>	3.2	32	0000 <sub>H</sub>	Underflow
< -270.0	-32768	8000 <sub>H</sub>	< -454.0	-32768	8000 <sub>H</sub>	< 3.2	-32768	8000 <sub>H</sub>	

## 10.1.7 Dynamic reference temperature with module 8 AI RTD/TC 8xM12

## Properties

You can measure the reference junction temperature of the measuring point by using the I/O device 8 AI RTD/TC 8xM12 or an external module from another station when you use the compensation type "Dynamic reference temperature". To do so, the reference temperature is transmitted with SFB 53 "WRREC" using the data record DS2 to the I/O device 8 AI RTD/TC 8xM12.

## Requirements

- Standard function block SFB 53 "WRREC"
- User program



## Programming

Observe the following notes on the user program:

- The permitted value range of the reference junction temperature in standard resolution corresponds to the temperature range Pt100 Climatic for platinum RTDs.
- If a reference junction temperature is received in data record DS2 that is outside the permitted value range, a diagnostic interrupt "Reference channel fault" is signaled if the "Group diagnostics" parameter has been enabled.
- All inputs signal overflow (32767) when you start the I/O device 8 AI RTD/TC 8xM12. After receiving a compensation value by means of the data record DS2, the I/O device starts reading the TC inputs and signals correct data.
- The I/O device 8 AI RTD/TC 8xM12 has a watchdog set to 5 minutes that is reset after a new compensation value was received by means of DS2. If the I/O device in standard operation does not receive DS2 data within the 5-minute interval of the watchdog, a diagnostic interrupt "Reference channel fault" is signaled if the "Group diagnostics" parameter has been enabled.
- When you use ET 200eco PN modules or other modules for measuring the reference junction temperature, the RTD module parameters/module parameters for the output structure and measuring accuracy must be represented in the DS2 by bytes 0 and 1. The figure below "Structure of data record DS2" illustrates this setting.



Table 10- 7 Reference temperature for TC

Temperature unit	Decimal	Hexadecimal
<b>Standard temperature unit</b>		
Celsius	-1450 to 1550	FA56 <sub>H</sub> to 60E <sub>H</sub>
Fahrenheit	-2290 to 3110	F70E <sub>H</sub> to C26 <sub>H</sub>
Kelvin	1282 to 4282	502 <sub>H</sub> to 10BA <sub>H</sub>
<b>Climatic temperature unit</b>		
Celsius	-14500 to 15500	C75C <sub>H</sub> to 3C8C <sub>H</sub>
Fahrenheit	-22900 to 31100	A68C <sub>H</sub> to 797C <sub>H</sub>
Kelvin	12815 to 32760	320F <sub>H</sub> to 7FF8 <sub>H</sub>

**Note**

You can use a separate reference junction for each channel due to the flexible structure of the data record DS2. You can also combine channels with the user program so that they use the same reference junction. All channels that operate with the same reference junction temperature must have the same temperature value in the DS2.

## User program

The following user program shows an example for the compensation type "Dynamic reference temperature" of channels 0 to 7 of the I/O device 8 AI RTD/TC 8xM12 of an RTD module. The reference junction temperature of the RTD module applies to all channels of the I/O device 8 AI RTD/TC 8xM12.

Requirements:

- Input address of the I/O device 8 AI RTD/TC 8xM12: 120 (module address)
- Input address of the RTD module: 136 (channel address)
- Request bit for SFB "WRREC": M 20.0
- Busy bit for SFB "WRREC": M 20.1
- Memory for data transmission: MW 0 to MW 16

STL	Explanation
UN M 20.0	Checking the request: New Dynamic Ref. Temp.
UN M 20.1	Checking if WRREC is "Busy"
SPB END	skip if no transmission is required
U M 20.1	Checking if WRREC is "Busy"
SPB WRT	
// Create memory for data transmission	
L B#16#1	Transmit temperature in hundredths of a degree (Pt100 Climatic)
T MB 0	
L B#16#0	Transmit temperature in Celsius
T MB 1	
L PIW 136	Read in reference junction temperature of an RTD module in the plant
T MW 2	for channel 0 of the 4 AI RTD/TC
T MW 4	for channel 1 of the 4 AI RTD/TC
T MW 6	for channel 2 of the 4 AI RTD/TC
T MW 8	for channel 3 of the 4 AI RTD/TC
T MW 10	for channel 4 of the 4 AI RTD/TC
T MW 12	for channel 5 of the 4 AI RTD/TC
T MW 14	for channel 6 of the 4 AI RTD/TC
T MW 16	for channel 7 of the 4 AI RTD/TC
// Transmit the reference junction temperature to the RTD/TC	
WRT :CALL "WRREC", DB53	
REQ :=M20.0	Request bit for data transmission
ID :=DW#16#78	Input address 120 of the 8 AI RTD/TC
INDEX :=2	Data record number must be set to 2
LEN :=18	Length 18 bytes
DONE :=	
BUSY :=M20.1	Busy bit from SFB "WRREC"
ERROR :=	
STATUS :=MD24	
RECORD :=P#M0.0 BYTE 18	Pointer to memory for data transmission, length 18 bytes

<b>STL</b>	<b>Explanation</b>
U M 20.1	Checking if WRREC is "Busy"
SPB END	
CLR	
= M 20.0	Reset request for Dynamic Ref. Temp.
END :NOP 0	

This is only an example. The logic and memory assignment have to be adapted to the structure of the used PLC program.

Addition information on SFB 53 "WRREC" is available in the System Software for S7-300/400 System and Standard Functions manual.

## 10.2 I/O device analog output

### 10.2.1 I/O device 4 AO U/I 4xM12

#### Article number

6ES7145-6HD00-0AB0

#### Properties

- 4 outputs for voltage or current output
- Output ranges:
  - $\pm 10$  V, resolution 15 bits + sign
  - 1 to 5 V, resolution 15 bits
  - 0 to 10 V, resolution 15 bits
  - $\pm 20$  mA, resolution 15 bits + sign
  - 4 to 20 mA, resolution 15 bits
  - 0 to 20 mA, resolution 15 bits
- Supply voltage DC 24 V
- Dimensions 60 x 175 mm
- Diagnostics
  - "Missing 1L+" supply voltage
  - "Sensor supply short-circuit"
  - "Wire break"
  - "Short-circuit"
  - "Overload"
- Parameterizable response to CPU/Master STOP
- Prioritized startup
- Media redundancy

---

#### Note

Incorrect intermediate values at the output are possible when supply voltage 1L+ is switched on and off.

---

#### Note

The outputs are in voltage mode and supply a signal 0 V until the parameter assignment becomes effective after switching on.

---

**Pin assignment**

You will find the pin assignment for the 4 AO U/I 4xM12 I/O device in the table below.

Table 10- 8 Pin assignment for voltage and current for the 4 AO U/I 4xM12 I/O device

Pin	Assignment for U/I				View of socket (front view)
	Socket X1	Socket X2	Socket X3	Socket X4	
1	24 V actuator supply 1U <sub>A</sub> (derived from 1L+ non-switched)				
2	Output signal				
	Q <sub>0+</sub>	Q <sub>1+</sub>	Q <sub>2+</sub>	Q <sub>3+</sub>	
3	Actuator supply ground 1M				
4	Output signal				
	Q <sub>0-</sub>	Q <sub>1-</sub>	Q <sub>2-</sub>	Q <sub>3-</sub>	
5	Functional earth FE				

**Block diagram**

The block diagram below shows the 4 AO U/I 4xM12.

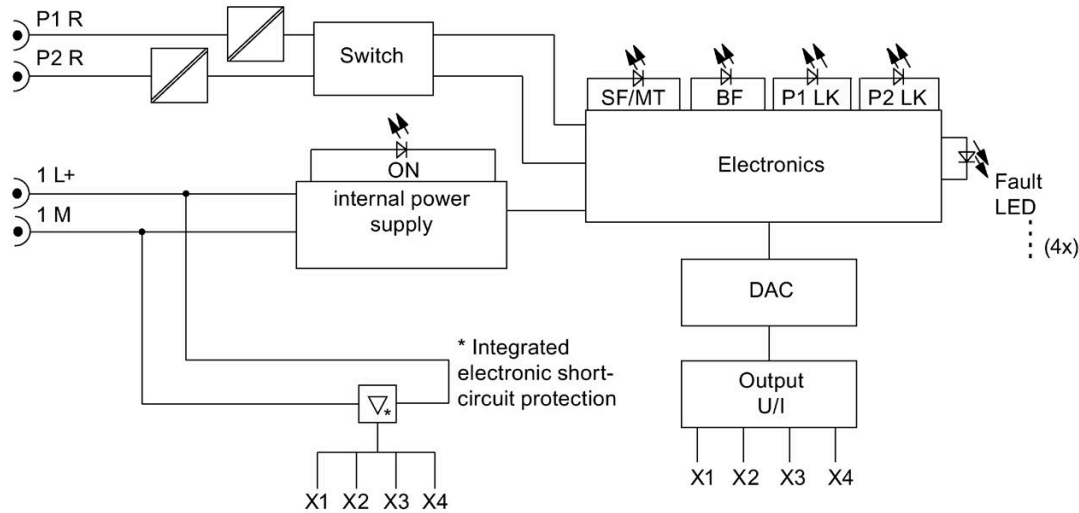

Figure 10-4 Block diagram 4 AO U/I 4xM12

## Technical specifications

Technical specifications	
<b>Dimensions and weight</b>	
Dimensions W x H x D (mm)	60 x 175 x 49
Weight	Approx. 930 g
<b>Module-specific data</b>	
Transmission rate	100 Mbps full duplex
Transmission mode	100BASE-TX
Autonegotiation	Yes
Bus protocol	PROFINET IO <ul style="list-style-type: none"> <li>• IRT with the option "high flexibility"</li> <li>• IRT with the option "high performance"</li> </ul>
Supported Ethernet services	PROFINET IO (Device) <ul style="list-style-type: none"> <li>• ping</li> <li>• arp</li> <li>• LLDP</li> <li>• Network diagnostics (SNMP)</li> <li>• DCP</li> <li>• Prioritized startup</li> <li>• Media redundancy</li> </ul>
<b>PROFINET interface</b>	
• Connection socket	2 x M12 d-coded
• Switch function	Yes, internal
• Auto-crossover	Yes, if autonegotiation is enabled
Manufacturer ID (Vendor ID)	002A <sub>H</sub>
Device ID (DeviceID)	0306 <sub>H</sub>
<b>Voltages and currents</b>	
Supply voltage 1L+	DC 24 V
• Reverse polarity protection	Yes; against destruction
• Infeed current 1L+	Max. 4 A
Supply voltage 2L+	DC 24 V
• Infeed current 2L+	Max. 4 A
<b>Current consumption</b>	
• From supply voltage (1L+)	Typ. 280 mA
• From supply voltage (2L+)	0 A
Power loss of the device	Typ. 5.5 W



<b>Technical specifications</b>	
<b>Analog outputs</b>	
Number of outputs	4
Cable length, shielded	Max. 30 m
Voltage	
• Short-circuit protection	Yes, electronic, to ground
• Short-circuit current	Max. 30 mA
Current	
• No-load voltage	Max. 20 V
<b>Actuator supplies</b>	
Number of actuator supplies	4
Total current	Max. 1 A
Short-circuit protection	Yes, electronic
• Response threshold	Min. 1.4 A
<b>Actuator selection data</b>	
Output ranges (Rated value)	
Voltage	±10 V 1 V to 5 V 0 V to 10 V
Current	±20 mA 4 to 20 mA 0 to 20 mA
Load resistance (in the Rated range of the output)	
• For voltage outputs	Min. 1 kΩ
• For voltage outputs, capacitive load	Max. 1 μF
• For current outputs	Max. 0.6 kΩ
• For current outputs, inductive load	Max. 1 mH
Permissible input voltage at the output (destruction limit)	28.8 V continuous, 35 V for 500 ms
Connection of actuators	
• For voltage output, 2-wire connection	Yes
• For current output, 2-wire connection	Yes
<b>Formation of analog values</b>	
Conversion principle	Resistor network
• Conversion time per channel, in ms	1 ms
• Voltage resolution (including overrange)	±10 V/15 bits + sign 1 to 5 V/15 bits 0 to 10 V/15 bits
• Current resolution (including overrange)	±20 mA/15 bits + sign 4 to 20 mA/15 bits 0 to 20 mA/15 bits

<b>Technical specifications</b>				
Settling time	U	I		
• For resistive load	1.3 ms	2 ms		
• For capacitive load	1.8 ms	-		
• For inductive load	-	2 ms		
Ability to switch to substitute values	Yes			
<b>Interference suppression, error limits</b>				
Crosstalk between outputs	Min. 70 dB			
Operational limit (across the temperature range, relative to output range)	Ambient temperature			
		positive	negative (0 °C to -25 °C)	negative (-25 °C to -40 °C)
	U	0.1%	0.15%	0.3%
	I	0.15%	0.25%	0.4%
Basic error limit (operational limit at 25°C, relative to output range)	U	0.08%		
	I	0.1%		
Temperature error (relative to output range)	Ambient temperature			
		positive	negative	
	U	0.001%/K	0.003%/K	
	I	0.0025%/K	0.005%/K	
Linearity error (relative to output range)	± 0.02%			
Repeat accuracy (in steady-state condition at 25°C, relative to output range)	±0.008%			
Output ripple (relative to output range, bandwidth 0 to 50 kHz)	U	±0.6 mVrms		
	I	±0.4 nArms		
<b>Status, interrupts, diagnostics</b>				
Interrupts	Yes			
Diagnostics functions				
• Group error/maintenance	Red/yellow "SF/MT" LED			
• Bus monitoring PROFINET IO	Red "BF" LED			
• Monitoring of supply voltage 1L+	Green "ON" LED			
• Existing connection to network	Green "P1 LK" and "P2 LK" LED; LED for PROFINET IO infeed and loop-through			
• Fault at analog output	Red LED			
• Diagnostic information can be read	Yes			
Monitoring for				
• Supply voltage 1L+	Yes			
• Sensor supply short-circuit	Yes			
• Short-circuit	Yes; channel (voltage)			
• Wire break	Yes; channel (current)			
• Thermal overload at output	Yes; channel			

<b>Technical specifications</b>	
<b>Insulation</b>	
Insulation test voltage	
• Ethernet interface	1500 V <sub>rms</sub> (IEEE802.3, Type Test)
• All other circuit elements	707 V DC (type test)
<b>Electrical isolation</b>	
• Between 1L+ and 2L+	Yes
• Between 1L+, channels and all other circuit elements	No
• Between channels	No
• Between Ethernet and all other circuit elements	Yes

**See also**

Response times for analog input device and output device (Page 273)

## 10.2.2 Parameter overview analog output

### Parameters for analog output 4 AO U/I 4xM12 (6ES7145-6HD00-0AB0)

Parameters	Range of values	Default setting	Range of effectiveness
Group diagnostics	<ul style="list-style-type: none"> <li>• Disable</li> <li>• Enable</li> </ul>	Disable	Device
Diagnostics, missing 1L+	<ul style="list-style-type: none"> <li>• Disable</li> <li>• Enable</li> </ul>	Disable	Device
Diagnostics, sensor supply short-circuit	<ul style="list-style-type: none"> <li>• Disable</li> <li>• Enable</li> </ul>	Disable	Device
Response to CPU/Master STOP	<ul style="list-style-type: none"> <li>• Output has no current or voltage</li> <li>• Retain last value</li> <li>• Switch to substitute values</li> </ul>	Output has no current or voltage	Device
Type of output	<ul style="list-style-type: none"> <li>• Disabled</li> <li>• Voltage</li> <li>• Current</li> </ul>	Voltage	Channel
Output range	<ul style="list-style-type: none"> <li>• 1 to 5 V</li> <li>• 0 to 10 V</li> <li>• <math>\pm 10</math> V</li> <li>• 0 to 20 mA</li> <li>• 4 to 20 mA</li> <li>• <math>\pm 20</math> mA</li> </ul>	$\pm 10$ V	Channel
Diagnostics, wire break at outputs	<ul style="list-style-type: none"> <li>• Disable</li> <li>• Enable</li> </ul>	Disable	Channel
Diagnostics, short-circuit at outputs	<ul style="list-style-type: none"> <li>• Disable</li> <li>• Enable</li> </ul>	Disable	Channel
Diagnostics, overload	<ul style="list-style-type: none"> <li>• Disable</li> <li>• Enable</li> </ul>	Disable	Channel
Substitute value	Each value in the nominal range, overrange, and underrange	0	Channel

Output range	Permitted substitute value
1 to 5 V	0.000 V to 5.704 V
0 to 10 V	0.000 V to 11.759 V
±10 V	-11.759 V to 11.759 V
0 to 20 mA	0.000 mA to 23.518 mA
4 to 20 mA	0.000 mA to 22.814 mA
±20 mA	-23.519 mA to 23.518 mA

### 10.2.3 Parameter description analog output

#### Group diagnostics

You can generally enable and disable the diagnostics function of the device with this parameter.

The "Fault" and "Parameter assignment error" diagnostics functions are always independent of the group diagnostics.

#### Diagnostics, missing 1L+

If you enable this parameter, the check for missing supply voltage is enabled.

#### Diagnostics, sensor supply short circuit

When this parameter is enabled, the system generates a diagnostics event if it detects a short-circuit of the sensor supply to ground. This diagnostics function is activated when the group diagnostics function is enabled.

#### Response to CPU/Master STOP

Select how the module's outputs will respond to a CPU STOP:

- Shut down  
The I/O device goes to the safe state. The process image output is deleted (=0).
- Keep last value  
The I/O device retains the last value to be output before STOP.
- Substitute value  
The I/O device outputs the value for the channel set beforehand.

---

#### Note

Make sure that the plant is always in a safe state if "Keep last value" is selected.

---

### Type of output

With this parameter, you set the output type, for example, voltage. For any unused channels, select the **disabled** setting. For a disabled channel, the conversion time and integration time of the channel = 0 s, and the cycle time is optimized.

### Output range

With this parameter, you set the output range of the selected output type.

### Diagnostics, wire break (in current mode)

When this parameter is enabled, the **Wire break** diagnostics event is generated when a wire break is detected. This diagnostics event cannot be detected in the zero range.

### Diagnostics, short circuit (in voltage mode)

If you enable this parameter, a diagnostics event is generated in the event of a short circuit in the output line. This diagnostics event cannot be detected in the zero range.

### Diagnostics, overload

If you enable this parameter, the diagnostics event is generated in the event of an overload.

### Substitute values

With this parameter, you enter a substitute value that the module is to output in CPU-STOP mode. The substitute value must be in the nominal range, overrange, or underrange.

## 10.2.4 Output ranges of analog output device

### Output ranges for voltage and current: $\pm 10$ V; $\pm 20$ mA

Output range $\pm 10$ V	Output range $\pm 20$ mA	Units		Range
		Decimal	Hexadecimal	
0.00 V	0.00 mA	32767	7FFF <sub>H</sub>	Overflow
		32512	7F00 <sub>H</sub>	
11.76 V	23.52 mA	32511	7EFF <sub>H</sub>	Overrange
		27649	6C01 <sub>H</sub>	
10 V	20 mA	27648	6C00 <sub>H</sub>	Nominal range
7.5 V	15 mA	20736	5100 <sub>H</sub>	
361.7 $\mu$ V	723.4 nA	1	0001 <sub>H</sub>	
0 V	0 mA	0	0000 <sub>H</sub>	
-361.7 $\mu$ V	-723.4 nA	-1	FFFF <sub>H</sub>	
-7.5 V	-15 mA	-20736	AF00 <sub>H</sub>	
-10 V	-20 mA	-27648	9400 <sub>H</sub>	
		-27649	93FF <sub>H</sub>	
-11.76 V	-23.52 mA	-32512	8100 <sub>H</sub>	Underrange
		-32513	80FF <sub>H</sub>	
0.00 V	0.00 mA	-32768	8000 <sub>H</sub>	Underflow

### Output ranges for voltage and current: 1 to 5 V; 4 to 20 mA

Output range 1 to 5 V	Output range 4 to 20 mA	Units		Range
		Decimal	Hexadecimal	
0.00 V	0.00 mA	32767	7FFF <sub>H</sub>	Overflow
		32512	7F00 <sub>H</sub>	
5.70 V	22.81 mA	32511	7EFF <sub>H</sub>	Overrange
		27649	6C01 <sub>H</sub>	
5 V	20 mA	27648	6C00 <sub>H</sub>	Nominal range
4 V	16 mA	20736	5100 <sub>H</sub>	
1 V + 144.7 $\mu$ V	4 mA + 578.7 nA	1	0001 <sub>H</sub>	
1 V	4 mA	0	0000 <sub>H</sub>	
		-1	FFFF <sub>H</sub>	
0 V	0 mA	-6912	E500 <sub>H</sub>	
		-6913	E4FF <sub>H</sub>	Underflow
0.00 V	0.00 mA	-32768	8000 <sub>H</sub>	

## Output ranges for voltage and current: 0 to 10 V; 0 to 20 mA

Output range 0 to 10 V	Output range 0 to 20 mA	Units		Range
		Decimal	Hexadecimal	
0.00 V	0.00 mA	32767	7FFF <sub>H</sub>	Overflow
		32512	7F00 <sub>H</sub>	
11.76 V	23.52 mA	32511	7EFF <sub>H</sub>	Overrange
		27649	6C01 <sub>H</sub>	
10 V	20 mA	27648	6C00 <sub>H</sub>	Nominal range
7.5 V	15 mA	20736	5100 <sub>H</sub>	
361.7 µV	723.4 nA	1	0001 <sub>H</sub>	
0 V	0 mA	0	0000 <sub>H</sub>	
		-1	FFFF <sub>H</sub>	Underflow
0.00 V	0.00 mA	-32768	8000 <sub>H</sub>	

## 10.3 Influence of the range of values

### Influence of analog signal on input value

The response of the I/O devices with analog inputs depends on the position of the input values within the range of values. The table below shows this dependency.

The measured value lies	Result	SF LED	Diagnostics data range of device	Interrupt
Within the nominal range	Measured value	-	-	-
Within the overrange/underrange	Measured value	-	-	-
Within the overflow	7FFF <sub>H</sub>	On	Entry <sup>1</sup>	Diagnostic interrupt <sup>1</sup>
Within the underflow	8000 <sub>H</sub>	On	Entry <sup>1</sup>	Diagnostic interrupt <sup>1</sup>
Before parameter assignment	7FFF <sub>H</sub>	-	-	-
Within an incorrect parameter assignment <sup>2</sup>	Measured value	On	Entry	Diagnostic interrupt
Within an incorrect initial parameter assignment	7FFF <sub>H</sub>	On	Entry	Diagnostic interrupt

<sup>1</sup> If the the **group diagnostics** and **measuring range** parameters are enabled for the input device.

<sup>2</sup> If a channel was previously parameterized correctly, it continues running with the last parameters.



### Influence of output value on analog output

The response of I/O devices with analog outputs depends on the position of the input values within the range of values. The table below shows this dependency.

The output value lies	Result	SF LED	Diagnostics data range of device	Interrupt
Within the nominal range	Value from the IO Controller	-	-	-
Within the overrange/underrange	Value from the IO Controller	-	-	-
Within the overflow	0 signal	-	-	-
Within the underflow	0 signal	-	-	-
Before parameter assignment	0 signal	-	-	-
Within an incorrect parameter assignment <sup>1</sup>	Value from the IO Controller	On	Entry	Diagnostic interrupt
Within an incorrect initial parameter assignment	0 signal	On	Entry	Diagnostic interrupt

<sup>1</sup> If a channel was previously parameterized correctly, it continues running with the last parameters.

## IO-Link Master

### 11.1 IO-Link Master (6ES7148-6JA00-0AB0)

#### Article number

6ES7148-6JA00-0AB0

#### Properties

The IO-Link Master 4 IO-L + 8 DI + 4 DO DC 24V/1,3A 8xM12 has the following technical specifications:

- IO-Link Master according to IO-Link specification V1.0
- Dimensions 60 x 175 mm
- Double assignment of the sockets
- 4 IO-Link ports (Port Class A)
- IO-Link ports can be used optionally as:
  - 4 IO-Link devices as 3-conductor connection
  - 4 standard actuators/encoders (SIO mode)
- 8 digital inputs and 4 digital outputs
- Digital inputs
  - Rated input voltage DC 24 V
  - Suitable for switches and proximity switches
  - Diagnostics
    - "Missing 2L+" for the I/O device
    - "Short-circuit to M at sensor supply", per channel group
    - "Wire break", per channel
  - Channels 4 to 7 are diagnostics-capable, Channels 0 to 3 do not have diagnostics.

- Digital outputs
  - Rated load voltage DC 24 V
  - Output current: 1.3 A per output
  - Suitable for solenoid valves, DC contactors, and indicator lights
  - Diagnostics
    - "Missing 2L+" for the I/O device
    - "Wire break at outputs" per channel
    - "Short-circuit to M at outputs" per channel
  - Parameterizable response to CPU/Master STOP
- Data transfer rates COM1 (4.8 kBaud), COM2 (38.4 kBaud)

The module supports the following functions:

- Prioritized startup
- Media redundancy (as of firmware V7.0)

## General pin assignment

Table 11- 1 Pin assignment of sockets X1 to X4 for IO-Link Master and digital inputs

Pin	Assignment				View of socket (front view)
	Socket X1	Socket X2	Socket X3	Socket X4	
1	24 V sensor supply 1Us(derived from 1L+ non-switched)				
2	Input signal				
	DI0	DI1	DI2	DI3	
3	Sensor supply ground 1M				
4	IO-Link port 1	IO-Link port 2	IO-Link port 3	IO-Link port 4	
5	Not used				

Table 11- 2 Pin assignment of the sockets X5 to X6 for digital inputs

Pin	Assignment		View of socket (front view)
	Socket X5	Socket X6	
1	24 V sensor supply 1Us(derived from 1L+ non-switched)		
2	Input signal		
	DI5	DI7	
3	Sensor supply ground 1M		
4	Input signal		
	DI4	DI6	
5	Functional earth FE		

Table 11- 3 Pin assignment of sockets X7 and X8 for digital outputs

Pin	Assignment		View of socket (front view)
	Socket X7 (2L+ switched)	Socket X8 (2L+ switched)	
1	Not used		
2	Output signal		
	DQ <sub>1</sub>	DQ <sub>3</sub>	
3	Supply ground 2M		
4	Output signal		
	DQ <sub>0</sub>	DQ <sub>2</sub>	
5	Functional earth FE		

## Block diagram

The figure below shows the block diagram of the IO-Link Master  
4 IO-L + 8 DI + 4 DO DC 24V/1,3A 8×M12.

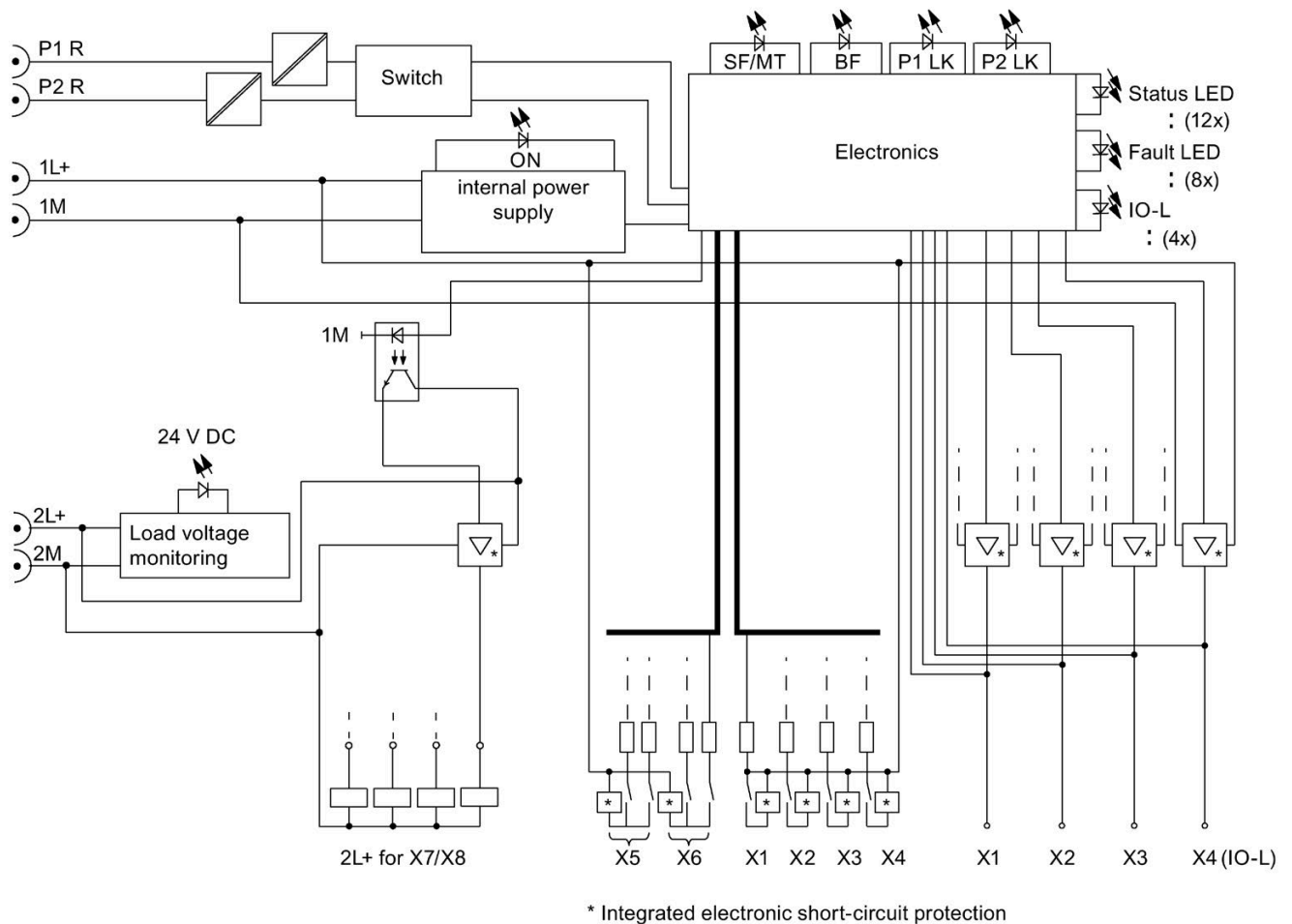

Figure 11-1 Block diagram of the IO-Link Master 4 IO-L + 8 DI + 4 DO DC 24V/1,3A 8×M12

## Technical data of the IO-Link Master

Technical data	
<b>Dimensions and weight</b>	
Dimensions W x H x D (mm)	60 x 175 x 49
Weight	Approx. 910 g
<b>Module-specific data</b>	
Transmission rate	100 Mbps full duplex
Transmission mode	100BASE-TX
Autonegotiation	Yes
Bus protocol	PROFINET IO <ul style="list-style-type: none"> <li>• IRT with the option "high flexibility"</li> </ul>
Supported Ethernet services	PROFINET IO (Device) <ul style="list-style-type: none"> <li>• ping</li> <li>• arp</li> <li>• LLDP</li> <li>• Network diagnostics (SNMP)</li> <li>• DCP</li> <li>• Prioritized startup</li> <li>• Media redundancy (as of firmware V7.0)</li> </ul>
<b>PROFINET interface</b>	
• Connection socket	2 × M12 d-coded
• Switch function	Yes, internal
• Auto-crossover	Yes; if autonegotiation is enabled
Manufacturer ID (Vendor ID)	002A <sub>H</sub>
Device ID (DeviceID)	0306 <sub>H</sub>
<b>Voltages and currents</b>	
Supply voltage 1L+	DC 24 V
• Reverse polarity protection	Yes; against destruction
• Infeed current 1L+	Max. 4 A
Supply voltage 2L+	DC 24 V
• Reverse polarity protection	Yes, against destruction, loads are activated
• Infeed current 2L+	Max. 4 A
<b>Total current of the outputs</b>	
• All mounting positions to 60°C	3.9 A
<b>Current consumption</b>	
From supply voltage (1L+)	Typ. 200 mA
From supply voltage (2L+)	Typ. 5 mA
Power loss of the device	Typ. 8 W

<b>Technical data</b>	
<b>Insulation</b>	
Insulation test voltage	
• Ethernet interface	1500 V <sub>rms</sub> (IEEE802.3, Type Test)
• All other circuit elements	707 V DC (type test)
<b>Electrical isolation</b>	
• Between 1L+ and 2L+	Yes
• Between 1L+, channels and all other circuit elements	No
• Between channels	No
• Between Ethernet and all other circuit elements	Yes
<b>Status, interrupts, diagnostics</b>	
Interrupts	Yes
Diagnostics function	Yes
• Group error/maintenance	Red LED / yellow LED "SF/MT"
• Bus monitoring PROFINET IO	Red "BF" LED
• Monitoring of supply voltage 1L+	Green "ON" LED
• Monitoring of supply voltage 2L+	Green "24 V DC" LED
• Existing connection to network	Green "P1 LK" and "P2 LK" LED; LED for PROFINET IO infeed and loop-through
• IO-Link port	Green LED "IO-L"
• Digital input/digital output	Green LED
• Fault at digital input/digital output	Red LED
• Diagnostic information can be read	Yes
<b>Monitoring for</b>	
• Missing 2L+	Yes
• Short-circuit of the sensor supply to M	Yes, for Channels 4 to 7, per channel group
• Short-circuit at output (Channel 0 to 3)	Yes, per channel
• Wire break at input	Input current < 0.3 mA per channel
• Wire break at output (Channel 0 to 3)	Yes, in the off state, per channel
<b>Sensor supply</b>	
Number of sensor supplies	6 (X1-X4 (IO-LINK/DI) and X5-X6 (DI))
Load current	200 mA per output to X1-X4 (IO-LINK/DI) 100 mA per output to X5-X6 (DI)
Short-circuit protection	Yes, electronic

<b>Technical data</b>	
<b>IO-Link port</b>	
Number of ports	4
Number of ports that can be controlled simultaneously	4, in all mounting positions
IO-Link protocol 1.0	Yes
IO-Link protocol 1.1	No
Transmission rate	4.8 kBaud (COM1), 38.4 kBaud (COM2)
Size of the process data, input per port	32 bytes
Size of the process data, input per module	32 bytes
Size of the process data, output per port	32 bytes
Size of the process data, output per module	32 bytes
<b>Digital inputs</b>	
Number of inputs	8
Number of inputs that can be controlled simultaneously	8, in all mounting positions
<b>Digital outputs</b>	
Number of outputs	4
<b>IO-Link Device selection data (Port 1 to 4)</b>	
Cable length, unshielded	Max. 20 m
<b>Connection of IO-Link devices</b>	
Port type A	Yes; with 3-wire cable
<b>Operating modes</b>	
IO-Link	Yes
DI	Yes
DQ	Yes
<b>Sensor selection data (input signals 0 to 7 only)</b>	
Cable length, shielded	Max. 30 m
Cable length, unshielded	Max. 30 m
Input voltage	
• Nominal value	DC 24 V
• For signal "1"	11 to 30 V
• For signal "0"	-3 to 5 V
Input current	
• At signal "1"	Typ. 7 mA
Input delay	
• At "0" to "1"	Typ. 3 ms
• At "1" to "0"	Typ. 3 ms
Input characteristic	According to IEC 61131, Type 3
Connection of 2-wire proximity switches	
• Permitted quiescent current	Max. 1.5 mA



<b>Technical data</b>	
<b>Actuator selection data (output signals 0 to 3 only)</b>	
Cable length, shielded	Max. 30 m
Cable length, unshielded	Max. 30 m
Output voltage	
• Nominal value	DC 24 V
• For signal "1"	Min. 1L+/2L+ (-0.8 V)
Output current	
• At signal "1"	Max. 1.3 A
• For "0" signal (residual current)	Max. 1.5 mA
Load resistance range	22 Ω to 3.3 kΩ
Lamp load	Max. 5 W
Parallel wiring of two outputs	
• To increase performance	No
• For redundant control of a load	Supported
Controlling of a digital input	Yes
Switching frequency	
• With resistive load	Max. 100 Hz
• With inductive load	Max. 0.5 Hz
• With lamp load	Max. 1 Hz
Limiting of the inductive shutdown voltage to lamp load	Typ. 1L+/2L+ (-47 V)
Short-circuit protection of the output	Yes, electronic
• Response threshold	Typ. 1.8 A (per channel)

### 11.1.1 Parameters for IO-Link Master

#### Parameters for the IO-Link Master 4 IO-L + 8 DI + 4 DO DC 24V/1,3A 8×M12

Parameters	Range of values	Default setting	Range of effectiveness	
<b>Slot 1 "4 IO-L"</b>				
Group diagnostics	<ul style="list-style-type: none"> <li>• Disable</li> <li>• Enable</li> </ul>	Disable	Slot 1	
Diagnostics enable for Ports 1	<ul style="list-style-type: none"> <li>• Disable</li> <li>• Enable</li> </ul>	Disable	Channel	
Diagnostics enable for Port 2	<ul style="list-style-type: none"> <li>• Disable</li> <li>• Enable</li> </ul>	Disable	Channel	
Diagnostics enable for Port 3	<ul style="list-style-type: none"> <li>• Disable</li> <li>• Enable</li> </ul>	Disable	Channel	
Diagnostics enable for Port 4	<ul style="list-style-type: none"> <li>• Disable</li> <li>• Enable</li> </ul>	Disable	Channel	
<b>Slot 2 "8 DI + 4 DO DC 24V/1,3A 8×M12"</b>				
Group diagnostics	<ul style="list-style-type: none"> <li>• Disable</li> <li>• Enable</li> </ul>	Disable	Slot 2	
Diagnostics: Missing 2L+	<ul style="list-style-type: none"> <li>• Disable</li> <li>• Enable</li> </ul>	Disable	Channel group	
Response to CPU/Master STOP	<ul style="list-style-type: none"> <li>• Shut down</li> <li>• Retain last value</li> </ul>	Shut down	Slot 2	
<b>Inputs</b>				
Channel 4	Diagnostics: Short-circuit of the sensor supply to M	<ul style="list-style-type: none"> <li>• Disable</li> <li>• Enable</li> </ul>	Disable	Channel group*
	Diagnostics: Wire break	<ul style="list-style-type: none"> <li>• Disable</li> <li>• Enable</li> </ul>	Disable	Channel
Channel 5	Diagnostics: Short-circuit of the sensor supply to M	<ul style="list-style-type: none"> <li>• Disable</li> <li>• Enable</li> </ul>	Disable	Channel group*
	Diagnostics: Wire break	<ul style="list-style-type: none"> <li>• Disable</li> <li>• Enable</li> </ul>	Disable	Channel
Channel 6	Diagnostics: Short-circuit of the sensor supply to M	<ul style="list-style-type: none"> <li>• Disable</li> <li>• Enable</li> </ul>	Disable	Channel group*
	Diagnostics: Wire break	<ul style="list-style-type: none"> <li>• Disable</li> <li>• Enable</li> </ul>	Disable	Channel

Parameters		Range of values	Default setting	Range of effectiveness
Channel 7	Diagnostics: Short-circuit of the sensor supply to M	<ul style="list-style-type: none"> <li>• Disable</li> <li>• Enable</li> </ul>	Disable	Channel group*
	Diagnostics: Wire break	<ul style="list-style-type: none"> <li>• Disable</li> <li>• Enable</li> </ul>	Disable	Channel
<b>Outputs</b>				
Channel 0	Diagnostics: Short-circuit of outputs to M	<ul style="list-style-type: none"> <li>• Disable</li> <li>• Enable</li> </ul>	Disable	Channel
	Diagnostics: Wire break	<ul style="list-style-type: none"> <li>• Disable</li> <li>• Enable</li> </ul>	Disable	Channel
Channel 1	Diagnostics: Short-circuit of outputs to M	<ul style="list-style-type: none"> <li>• Disable</li> <li>• Enable</li> </ul>	Disable	Channel
	Diagnostics: Wire break	<ul style="list-style-type: none"> <li>• Disable</li> <li>• Enable</li> </ul>	Disable	Channel
Channel 2	Diagnostics: Short-circuit of outputs to M	<ul style="list-style-type: none"> <li>• Disable</li> <li>• Enable</li> </ul>	Disable	Channel
	Diagnostics: Wire break	<ul style="list-style-type: none"> <li>• Disable</li> <li>• Enable</li> </ul>	Disable	Channel
Channel 3	Diagnostics: Short-circuit of outputs to M	<ul style="list-style-type: none"> <li>• Disable</li> <li>• Enable</li> </ul>	Disable	Channel
	Diagnostics: Wire break	<ul style="list-style-type: none"> <li>• Disable</li> <li>• Enable</li> </ul>	Disable	Channel

\* Channel group is defined by the digital inputs of the M12 socket. Example:

- Channel 4 and Channel 5 form the channel group of connection socket X5.
- Channel 6 and Channel 7 form the channel group of connection socket X7.

Generally short-circuit monitoring of the M12 digital input socket is only carried once via Pin 1 (1L+) and Pin 3 (1M). The short-circuit parameterization can be used to select which channel of the M12 socket reports the short-circuit or whether both channels report the short-circuit.

## 11.1.2 Functions

### Introduction

You can select one of the following operating modes for each of the four ports of the IO-Link Master:

- IO-Link
- DI
- DQ
- Disabled

You make the selection in the Port Configurator tool during parameterization. If no parameters have been assigned, the ports will be disabled.

---

#### Note

##### Value status

The value status (PortQualifier) is relevant in IO-Link mode only.

---

### Value status

Each port has a value status display (PortQualifier) per device. The value status shows if the process data is valid or invalid.

By default, the value status (PortQualifier) is disabled.

### IO-Link

In IO-Link mode, the port is in IO-Link communication. There are two data transmission rates in this operating mode. COM1 with 4.8 kBaud; COM2 with 38.4 kBaud. The data transmission rate depends on the IO-Link Device used. The IO-Link Master and the IO-Link Device used automatically negotiate the maximum data transmission rate at startup.

### DI

In DI mode, a port of the IO-Link Master behaves like a standard DI.

### DQ

In DQ mode, a port of the IO-Link Master behaves like a standard DQ.

### Disabled

The respective port of the IO-Link Master is disabled in Disabled mode. The ports are disabled if the IO-Link Master has not yet been parameterized with *S7-PCT* (default setting).

## Consistency width of 8 byte

The IO-Link Master has a consistency width of 8 byte. In addition to the upper limit of 32 byte input and 32 byte output for the entire IO-Link Master, there are other upper limits of 8 byte input and 8 byte output per IO-Link Device (per port).

## 11.2 IO-Link Master (6ES7148-6JD00-0AB0)

### Article number

6ES7148-6JD00-0AB0

### Properties

The IO-Link Master 4 IO-L 4×M12 has the following technical specifications:

- IO-Link Master according to IO-Link specification V1.1
- Dimensions 30 x 200 mm
- 4 IO-Link ports (Port Class B)
- IO-Link ports can be used optionally as:
  - 4 IO-Link devices (Port Class A oder Class B) with variable address area up to 32 byte inputs/32 byte outputs per port
  - 4 standard actuators/encoders (SIO mode)
- Data transfer rates COM1 (4.8 kBaud), COM2 (38.4 kBaud), COM3 (230.4 kBaud)
- Identification and maintenance data I&M0 to I&M3
- Media redundancy
- Configurable diagnostics can be set per port (in IO-Link mode)
- Hardware interrupts (in IO-Link mode)

The module supports the following functions:

Table 11- 4 Version dependencies of the functions of the module

Function	Firmware version of the module
Master backup with function block "LIOLink_Master"	As of V1.0
Port Qualifier Information (PQI)	As of V1.0
IO-Link port configuration with S7-PCT (as of V3.4)	As of V1.0
IO-Link port configuration without S7-PCT	
<ul style="list-style-type: none"> <li>• IO-Link auto start</li> <li>• IO-Link manual</li> </ul>	As of V1.0 As of V1.1

### General pin assignment

Table 11-5 Pin assignment of sockets X1 to X4 for IO-Link master

Pin	Assignment				View of socket (front view)
	Socket X1	Socket X2	Socket X3	Socket X4	
1	24 V sensor supply 1Us (derived from 1L+ non-switched)				
2	24 V actuator supply 2Ua (derived from 2L+ switched)				
3	Sensor supply ground 1M				
4	IO-Link port 1	IO-Link port 2	IO-Link port 3	IO-Link port 4	
5	Actuator supply ground 2M				

Additional information on pin assignment including wiring examples for the 3- and 5-conductor connection (Port Class A or Class B) is available in the chapter Pin assignment for IO-Link Masters (Page 50).

### Block diagram

The figure below shows the block diagram of the IO-Link master 4 IO-L 4xM12.

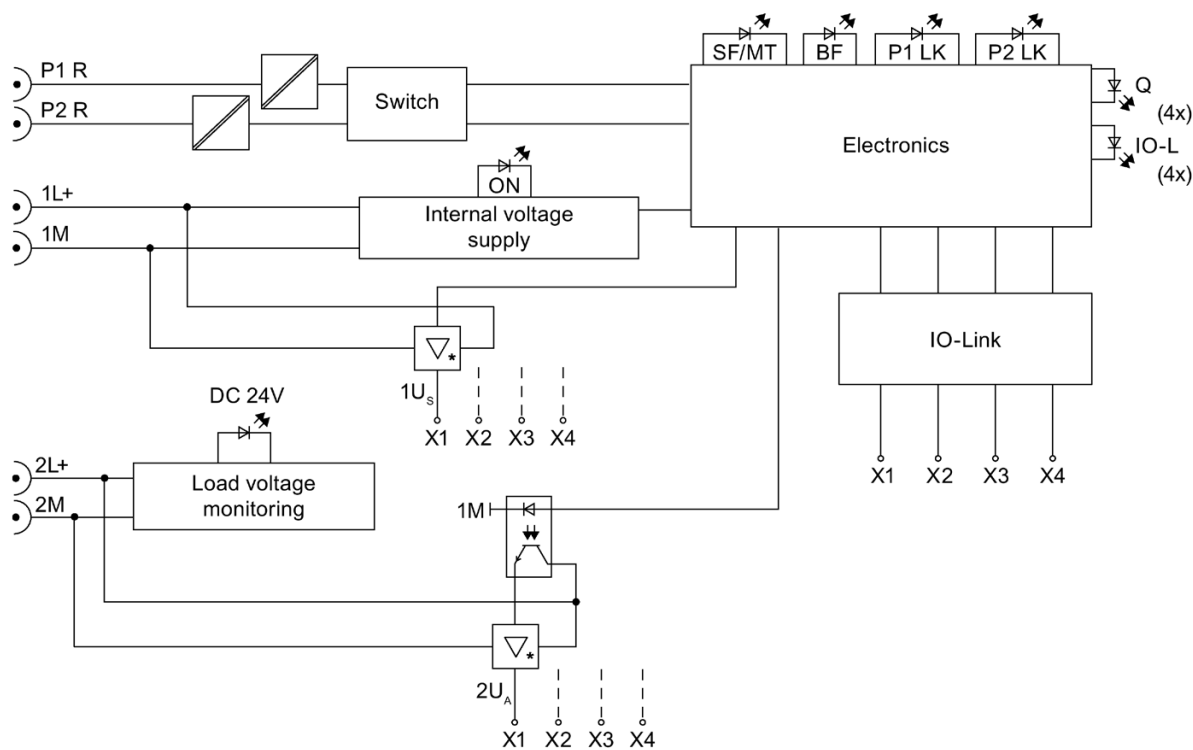

\* Integrated electronic short-circuit protection

Figure 11-2 Block diagram of the IO-Link Master 4 IO-L 4xM12

## Technical specifications of the IO-Link Master

<b>Technical specifications</b>	
<b>Dimensions and weight</b>	
Dimensions W x H x D (mm)	30 x 200 x 49
Weight	Approx. 550 g
<b>Module-specific data</b>	
Transmission rate	100 Mbps full duplex
Transmission mode	100BASE-TX
Autonegotiation	Yes
Bus protocol	PROFINET IO <ul style="list-style-type: none"> <li>• IRT</li> </ul>
Supported Ethernet services	PROFINET IO (Device) <ul style="list-style-type: none"> <li>• ping</li> <li>• arp</li> <li>• LLDP</li> <li>• Network diagnostics (SNMP)</li> <li>• DCP</li> <li>• Media redundancy</li> </ul>
<b>PROFINET interface</b>	
• Connection socket	2 x M12 d-coded
• Switch function	Yes, internal
• Autocrossing	Yes; if autonegotiation is enabled
Manufacturer ID (Vendor ID)	002A <sub>H</sub>
Device ID (DeviceID)	0306 <sub>H</sub>
<b>Voltages and currents</b>	
Supply voltage 1L+	DC 24 V
• Reverse polarity protection	Yes
• Infeed current 1L+	Max. 4 A
Load voltage 2L+	DC 24 V
• Reverse polarity protection	Yes, against destruction, loads are activated
• Infeed current 2L+	Max. 4 A
<b>Current consumption</b>	
From supply voltage (1L+)	Typ. 100 mA
From supply voltage (2L+)	Typ. 15 mA
Power loss of the device	Typ. 4.8 W
<b>Insulation</b>	
Insulation test voltage	
• Ethernet interface	1500 V <sub>rms</sub> (IEEE802.3, Type Test)
• All other circuit elements	707 V DC (type test)

<b>Technical specifications</b>	
<b>Electrical isolation</b>	
• between 1L+ and 2L+	Yes
• between 1L+, channels and all other switching parts	No
• Between channels	No
• between Ethernet and all other switching parts	Yes
<b>Status, interrupts, diagnostics</b>	
Interrupts	Yes
• Hardware interrupt (device notification)	Yes
Diagnostics function	Yes
• Group error/maintenance	Yes; red/yellow LED "SF/MT"
• Bus monitoring PROFINET IO	Red "BF" LED
• Monitoring of supply voltage 1L+	Green "ON" LED
• Monitoring of supply voltage 2L+	Green "24 V DC" LED
• Existing connection to network	Green "P1 LK" and "P2 LK" LED for PROFINET IO infeed and loop-through
• IO-Link port – Port in IO-Link mode – Port in SIO mode	green/red LED "IO-L" Green LED "Q"
• Diagnostic information can be read	Yes
Monitoring for	
• Missing 2L+	Yes
• Sensor supply short-circuit	Yes; device supply to ground
<b>Sensor supply</b>	
Number of outputs	4
Load current	500 mA per output
Short-circuit protection	Yes, electronic
<b>IO-Link port</b>	
Number of ports	4
Number of ports that can be controlled simultaneously	4, in all mounting positions
IO-Link protocol 1.0	Yes
IO-Link protocol 1.1	Yes
Transmission rate	4.8 kBaud (COM1), 38.4 kBaud (COM2), 230.4 kBaud (COM3)
Size of the process data, input per port	32 bytes + 1 byte PQI
Size of the process data, input per module	128 bytes + 4 bytes PQI
Size of the process data, output per port	32 bytes
Size of the process data, output per module	128 bytes
Memory size for device parameters	2 Kbytes; for each port



Technical specifications	
Master backup	possible; with function block LIOLink_Master
Configuration without S7-PCT	supported; autostart function
Data for selection of an IO-Link device	
Cable length, unshielded	Max. 20 m
Connection of IO-Link devices	
Port type A	Yes; with 3-wire cable
Port type B	Yes; additional device supply: Max. 2 A per Port, max. 4 A per module
Operating modes	
IO-Link	Yes
DI	Yes
DQ	Yes; max. 100 mA

## 11.2.1 Configuration

### Introduction

The IO-Link Master 4 IO-L 4×M12 has four ports. Each port is represented by a submodule.

### Configuration of the IO-Link port of the IO-Link Master 4 IO-L 4×M12

You specify the various operating modes of each IO-Link port by configuring a relevant submodule:

- as digital input by configuring a digital input submodule,
- as digital output by configuring a digital output submodule,
- as IO-Link device by configuring an IO-Link submodule.
- Port deactivated:
  - In STEP 7 V5.5 and higher and with GSD: By deleting the submodule,
  - in STEP 7 (TIA Portal): By deactivating the port enable.

The IO-Link ports are preconfigured as 2I + PQI.

When configuring IO-Link submodules, you can select address spaces for I/O data in the following byte scales:

- 1 I/1 O + PQI
- 2 I + PQI
- 2 I/2 O + PQI
- 4 I/4 O + PQI
- 8 I/8 O + PQI
- 16 I/16 O + PQI
- 32 I/32 O + PQI

**Note****Port Qualifier Information (PQI)**

The Port Qualifier Information (PQI) with the size of 1 byte is always transferred together with the input data of the IO-Link device. The PQI cannot be deactivated. Additional information on the structure of the PQI byte is available in the appendix I/O address space (Page 265).

Various parameters are available depending on the operating mode.

More information on the parameters is available in the chapter Parameter (Page 234).

## 11.2.2 Parameter

### Port parameters for the IO-Link Master 4 IO-L 4×M12

The following tables show the parameters that you can set for each submodule (each port) of the 4 IO-L 4×M12 IO-Link Master.

Table 11- 6 Diagnostics

Parameters	Range of values	Default setting
Diag: Missing 2L+	<ul style="list-style-type: none"> <li>• Disable</li> <li>• Enable</li> </ul>	Disable
Diag: Port	<ul style="list-style-type: none"> <li>• Disable</li> <li>• Enable</li> </ul>	Disable
Hardware interrupt (device notification)	<ul style="list-style-type: none"> <li>• Disable</li> <li>• Enable</li> </ul>	Disable

The following table shows the port parameters for 4 IO-L 4×M12 the IO-Link Master with firmware as of V1.1.

Table 11- 7 Port parameter

Parameter	Range of values	Default setting
Port configuration without S7-PCT	<ul style="list-style-type: none"> <li>• Disable</li> <li>• Enable</li> </ul>	Disable
Operating mode	<ul style="list-style-type: none"> <li>• IO-Link auto start</li> <li>• IO-Link manual</li> </ul>	IO-Link auto start
VendorID*	Manufacturer ID of the connected IO-Link device	0
DeviceID*	Device ID of the connected IO-Link device	0
Test accuracy / data backup*	<ul style="list-style-type: none"> <li>• Same type (V1.0) without backup &amp; restore</li> <li>• Type compatible (V1.1) without backup &amp; restore</li> <li>• Type compatible (V1.1) with backup &amp; restore</li> <li>• Type compatible (V1.1) with restore</li> </ul>	Type compatible (V1.1) with backup & restore

\* Only effective if you use the port mode "IO-Link Manual".

### 11.2.3 Explanation of the parameters

#### Diag: Missing 2L+

Enabling of diagnostics in the case of missing or insufficient load voltage 2L+.

#### Diag: Port

Enabling of the diagnostics for the selected port.  
A distinction is made between error and maintenance interrupts during the diagnostics. The possible diagnostics depend IO-Link device used. More information on the diagnostic interrupts is available in the description of the IO-Link device that is used.

### Hardware interrupt (device notification)

Enabling of hardware interrupts for the selected port.

The possible hardware interrupts depend on the IO-Link device that is used. More information on the hardware interrupts is available in the description of the IO-Link device that is used.

---

**Note****Configuration as digital input or output**

Please note that you cannot activate any port parameters or diagnostic alarms in SIO mode.

---

### Port configuration without S7-PCT

This parameter enables the port configuration without S7-PCT for the module.

---

**Note****Changes to the port configuration**

If you have assigned the parameters for the IO-Link device via port configuration without S7-PCT, or have configured the port as digital input, digital output or disabled, you can no longer change the port configuration via S7-PCT.

---

### Operating mode

This parameter specifies the mode in which the selected port is to be operated.

The following options are available for selection:

- IO-Link auto start
- IO-Link manual

**IO-Link auto start**

The connected IO-Link device starts automatically (Plug & Play functionality). The IO-Link device is operational and immediately available to you.

**IO-Link manual**

The connected IO-Link Device is **not** started automatically.

You have to store the VendorID and DeviceID of the connected IO-Link Device in STEP 7.

In addition, you can select the test accuracy for data storage:

- Same type (V1.0) without backup & restore
- Type compatible (V1.1) without backup & restore
- Type compatible (V1.1) with backup & restore
- Type compatible (V1.1) with restore

You can find the VendorID and DeviceID on the Internet

(<https://support.industry.siemens.com/cs/ww/en/view/109748852>).

### See also

I/O address space (Page 265)

## 11.2.4 Functions

### Introduction

A brief overview of the functions of the 4 IO-L 4×M12 IO-Link Master is presented below.

### Master backup

The "LIOLink\_Master" function block is used to read all relevant IO-Link device and IO-Link master parameters. These can be stored retentively at a central location, for example, in a data block in the IO controller.

The status of the IO-Link devices or IO-Link ports stored in the IO-Link master can be restored with the "LIOLink\_Master" function block.

As a result, the IO-Link ports and the IO-Link master are configured with the values stored in the master backup.

A typical use case is restoring the parameters after the exchange of the IO-Link master.

---

#### Note

##### Availability

Note that the Master Backup function is only available for IO-Link devices that are specified for the IO-Link standard as of V1.1.

---

More information on the use of the function blocks for the master backup and master restore is available in the chapter Acyclic data exchange with the IO-Link library (Page 83).

More information on Master Backup and Master Restore is available in the Master Backup section of the Integration in the Automation System chapter of the IO-Link System (<https://support.industry.siemens.com/cs/ww/en/view/65949252>) function manual.

### Identification and maintenance data

The identification and maintenance data (I&M data) is information that is saved as read-only (I data) or read/write (M data) on the module.

**Identification data (I&M0):** Manufacturer information on the module to which you only have read access and some of which may be printed on the module housing, for example, article number and serial number.

**Maintenance data (I&M1, 2, 3):** Plant dependent information, such as installation location.

The identification data I&M support you in the following tasks:

- Checking the plant configuration
- Locating hardware modifications in a plant
- Correcting errors in a plant

Modules are uniquely identifiable online with the I&M identification data.

In addition, you can read the identification data contained in the IO-Link device as I&M0 via the associated submodule.

## Port Qualifier Information (PQI)

Each port has a PortQualifierInformation (PQI). This PQI provides information on the port and IO-Link device status. The PQI is transferred cyclically with the process data. The PQI cannot be deactivated.

The structure of the PQI byte is available in the appendix I/O address space (Page 265).

## Port configuration

With a 4 IO-L 4xM12 IO-Link Master as of firmware version V1.1 you can commission the IO-Link submodules (ports) of the IO-Link Masters or the connected IO-Link Devices in two different ways:

- Port configuration without S7-PCT
- Port configuration with S7-PCT

### Port configuration without S7-PCT

#### Requirement

You have activated the "Port configuration with S7-PCT" check box at the configuration of the IO-Link Master submodules in STEP 7.

#### Procedure

You carry out the configuration of the IO-Link Master submodules directly in STEP 7:

- Activating diagnostics
- Port mode:
  - Operation in "IO-Link auto start" mode (pre-selected)
  - Operation in "IO-Link manual" mode

---

#### Note

#### Changing settings of IO-Link devices

If in the further course of the project you want to carry out settings at the connected IO-Link Devices with S7-PCT, you require S7-PCT as of V3.5 with Hotfix 1.

---

### Port configuration with S7-PCT

#### Requirement

You have **deactivated** (default) the "Port configuration without S7-PCT" check box for the configuration of all the IO-Link Master submodules in STEP 7.

#### Procedure

You carry out the port configuration of the IO-Link Master via the Port Configuration Tool S7-PCT as of V3.2.

You can find more detailed information on the submodule configuration in the section "Configuration (Page 233)".

## 11.2.5 Interrupts

### Introduction

According to IEC 61131-9, IO-Link devices are able to generate events of the types error, warning and notification. These events are mapped directly to the interrupts of the assigned submodule.

### Evaluating interrupts with IO controller

The IO-Link Master 4 IO-L 4×M12 supports the following interrupts:

- Diagnostic interrupts (at IO-Link Master / at submodule port)
- Hardware interrupts (at submodule port)
- Pull/plug interrupts (at submodule port)
- Maintenance events (at submodule port)

In the case of an interrupt, the CPU of the IO controller automatically calls the interrupt OBs. The OB number and the start information provide you with information about the cause and class of the error.

You can obtain detailed information on the error event in the error OB with the "RALRM" instruction (read supplementary interrupt information).

### System diagnostics

In STEP 7 (TIA Portal), the innovated system diagnostics is available for the devices of the S7-1500 automation system (IO controller CPU S7-1500) and ET 200eco PN (IO device). Alarms are made available on the display of the S7-1500 CPU, the CPU Web server and the HMI device.

More information on system diagnostics is available in the Diagnostics function manual on the Internet (<https://support.industry.siemens.com/cs/ww/en/view/59192926>).

### 11.2.5.1 Triggering of a diagnostic interrupt

#### Introduction

All IO-Link events of the type error, which the IO-Link Device generates, as well as problems and errors at the IO-Link port (for example Diag: Missing 2L+), are mapped to the diagnostic interrupts for the assigned submodule.

#### Triggering of a diagnostic interrupt

If you have assigned the parameters for the IO-Link master accordingly, this triggers a diagnostic interrupt for an incoming or outgoing event of the IO-Link device.

The CPU interrupts the processing of the user program and processes the diagnostic interrupt OB (OB 82). The event that led to the triggering of the interrupt is entered in the start information of the diagnostic interrupt OB.

### 11.2.5.2 Triggering a hardware interrupt

#### Introduction

All IO-Link events of the type notification which the IO-Link device generates are mapped to the hardware interrupts of the assigned submodule.

#### Triggering a hardware interrupt

In the event of a hardware interrupt the CPU interrupts the processing of the user program and processes the hardware interrupt OB (for example, OB 40). The event that led to the triggering of the interrupt is entered in the start information of the hardware interrupt OB.

### 11.2.5.3 Triggering of a pull/plug interrupt

#### Introduction

If you remove an IO-Link device or interrupt communication, a pull interrupt is generated by the assigned submodule.

A plug interrupt is triggered as soon as the IO-Link device is plugged in again or IO-Link communication re-established.

#### Triggering of a pull/plug interrupt

In the case of a pull/plug interrupt, the CPU interrupts the processing of the user program and process the pull/plug OB (OB 83). The event that led to the triggering of the interrupt is entered in the start information of the pull/plug OB.



## 11.2.6 Maintenance events

### Introduction

All IO-Link events of the type warning which the IO-Link device generates are mapped to the maintenance interrupts of the assigned submodule. The objective is early detection and elimination of potential disturbances.

With the IO-Link master, maintenance events indicate to the user when a check or an exchange of network components is required.

The CPU interrupts processing of the user program and processes the diagnostics block OB82. The event which led to the triggering of the maintenance event is entered in the start information of the OB82.

### System alarms in STEP 7 (TIA Portal)

The maintenance information is generated in STEP 7 (TIA Portal) with the following system alarms:

- Maintenance demanded - symbolized for each port by a wrench (on a yellow background)  in the device view or in the hardware configuration.

You can find additional information in the STEP 7 online help.

## Terminal block and voltage distributor

### 12.1 Terminal block

#### Article number

6ES7194-6CA00-0AA0

#### Properties

The terminal block has the following properties:

- The terminal block can be inserted and screw-mounted on any I/O device
- It can also be used separately.
- It distributes 10 A per supply voltage 1L+ and 2L+ to the I/O devices. You can tap a maximum load of 4 A from each supply voltage of the I/O device. The voltages are protected with two 7.5 A fuses.

#### Pin assignment

The tables below show the pin assignments.

Table 12- 1 Pin assignment of the terminal block

Pin	Assignment	View of the insulation displacement terminal block:
1	24 V (1L+ non-switched)	
2	Ground 1M (non-switched)	
3	24 V (2L+ switched)	
4	Ground 2M (switched)	

Table 12- 2 Pin assignment of the M12 connector

Pin	Assignment	View of the cable connector
1	24 V (1L+ non-switched)	
2	Ground 2M (switched)	
3	Ground 1M (non-switched)	
4	24 V (2L+ switched)	

## Block diagram

The block diagram below shows the terminal block.

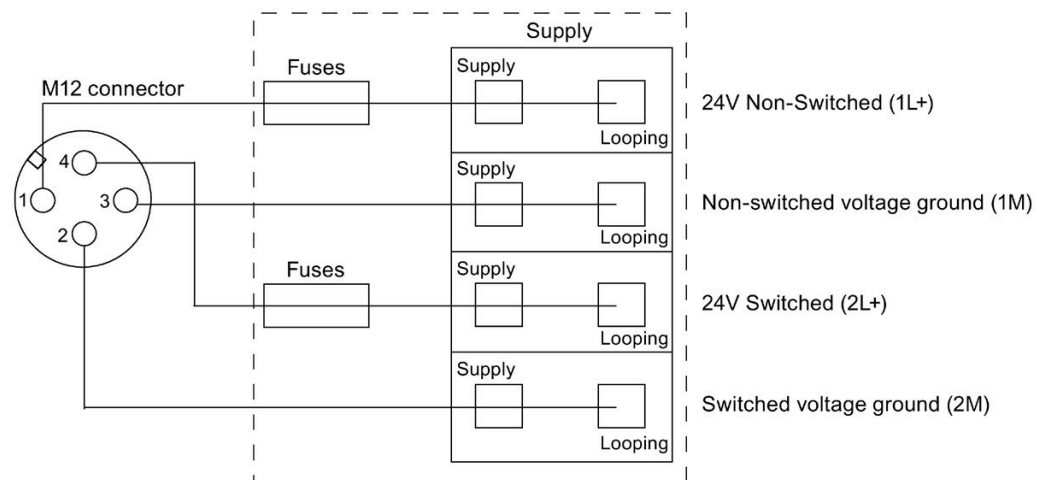

Figure 12-1 Block diagram of the terminal block

## Technical specifications

Dimensions and Weight	
Dimensions W x H x D (mm)	30 x 50 x 98
Weight	Approx. 90 g
Current	
Infeed current 1L+ and 2L+	Max. 10 A per 1L+ and 2L+
Output current via the M12 connector	Max. 4 A per 1L+ and 2L+
Power loss	
Power loss of the terminal block	1 W, typical

## See also

Installing the terminal block (Page 25)

## 12.2 Voltage distributor

### Article number

6ES7148-6CB00-0AA0

### Properties

The voltage distributor PD DC 24V 1×7/8" 4×M12 has the following properties:

- It distributes the centrally fed supply voltage (7/8") to 4 connectors (M12).
- Integrated electronic short-circuit protection
- Direct connection of up to 4 I/O devices
- Distribution of 1L+ and 2L+

### Pin assignment

The tables below show the pin assignments.

Table 12- 3 Pin assignment of the 7/8" connector as current input

Pin	Assignment	View of the 7/8" cable connector, 24 V connection
1	Ground 2M (switched)	
2	Ground 1M (non-switched)	
3	Functional earth FE	
4	24 V (1L+ non-switched)	
5	24 V (2L+ switched)	

Table 12- 4 Pin assignment of the M12 connector as current output

Pin	Assignment	View of the M12 connection plug (front view)
1	24 V (1L+ non-switched)	
2	Ground 2M (switched)	
3	Ground 1M (non-switched)	
4	24 V (2L+ switched)	
5	Not used	

**Block diagram**

The figure below shows the block diagram of the voltage distributor PD DC 24V 1×7/8" 4×M12.

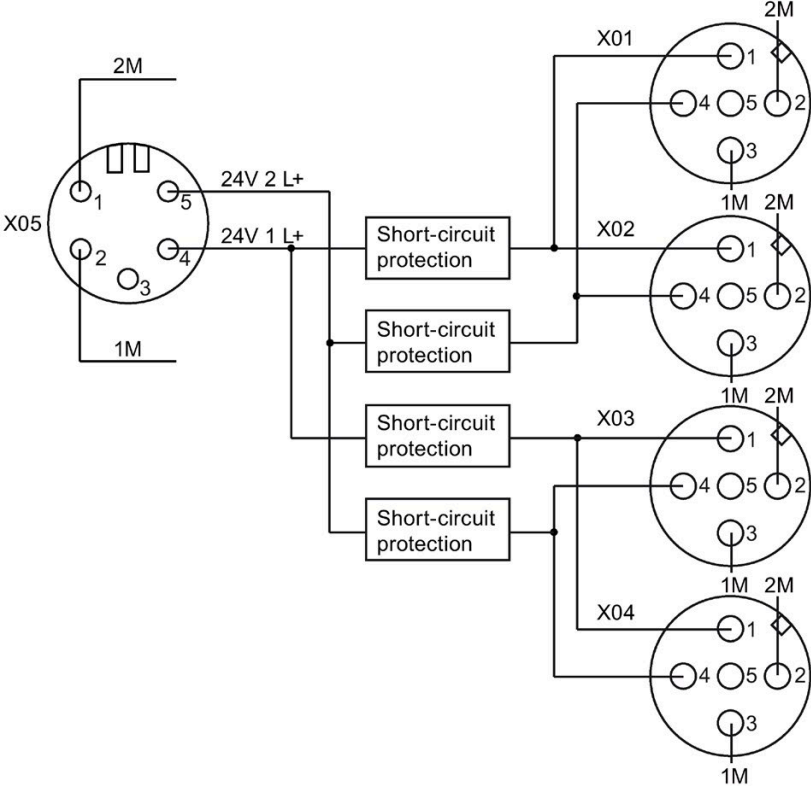

Figure 12-2 Block diagram of the voltage distributor PD DC 24V 1×7/8" 4×M12

## Technical specifications

<b>Dimensions and Weight</b>	
Dimensions W x H x D (mm)	45 x 175 x 49
Weight	Approx. 590 g
<b>Voltages and currents</b>	
Supply voltage 1L+	DC 24 V
• Reverse polarity protection	Yes; against destruction (continuously without load)
• Infeed current 1L+	8 A
Supply voltage 2L+	DC 24 V
• Reverse polarity protection	Yes; against destruction (continuously without load)
• Infeed current 2L+	8 A
<b>Total current of the outputs</b>	
• All mounting positions to 45 °C	for X1 and X2 in total max. 4 A for 1L+ for X1 and X2 in total max. 4 A for 2L+ for X3 and X4 in total max. 4 A for 1L+ for X3 and X4 in total max. 4 A for 2L+
• All mounting positions to 55 °C	for X1 and X2 in total max. 3 A for 1L+ for X1 and X2 in total max. 3 A for 2L+ for X3 and X4 in total max. 3 A for 1L+ for X3 and X4 in total max. 3 A for 2L+
• Number of outputs	4, with 1L+ and 2L+ each
Input voltage/loop-through	Green LED "1L+" and "2L+"
• Nominal value	DC 24 V
Short-circuit protection of the output	Yes, electronic
• Response threshold	Typ. 4.5 A
Power loss of the voltage distributor	Typ. 3.5 W
<b>Insulation</b>	
Insulation test voltage	
• Ethernet interface	1500 V <sub>rms</sub> (IEEE802.3, Type Test)
• All other circuit elements	707 V DC (type test)
<b>Electrical isolation</b>	
• Between 1L+ and 2L+	Yes
<b>Status, interrupts, diagnostics</b>	
Diagnostics functions	
• Input/output voltage	Green LED "1L" and "2L"

# Signal names

## A.1 Signal names

### Signal names of the I/O devices

Table A- 1 Signal names of the digital inputs and digital outputs (DI/DQ)

Signal name	Meaning
xL+	Input external auxiliary voltage DC (x: load group)
xM	Ground external auxiliary voltage DC (x: load group)
DI <sub>xUs</sub>	Digital input (x: load group)
DQ <sub>xUs</sub>	Digital output (x: load group)
DIQ <sub>xUs</sub>	Digital input/digital output (x: load group)
U <sub>Sn</sub>	Sensor supply voltage, channel n
1Us	24 V sensor supply 1Us(derived from 1L+ non-switched)

Table A- 2 Signal names of the analog inputs (AI)

Signal name	Meaning
xL+	Input external auxiliary voltage (x: load group)
xM	Ground external auxiliary voltage (x: load group)
M <sub>n+</sub>	Measuring input channel n (voltage, current, RTD, TC, etc.)
M <sub>n-</sub>	Measuring input channel n (voltage, current, RTD, TC, etc.)
I <sub>cn+</sub>	Power output power supply RTD channel n
I <sub>cn-</sub>	Power output power supply RTD channel n
U <sub>Vn+</sub>	Infeed voltage for 2DMU
U <sub>Sn</sub>	Sensor supply voltage, channel n
1Us	24 V sensor supply 1Us(derived from 1L+ non-switched)

Table A- 3 Signal names of the analog outputs (AQ)

Signal name	Meaning
xL+	Input external auxiliary voltage (x: load group)
xM	Ground external auxiliary voltage (x: load group)
Q <sub>n+</sub>	Output channel n (current or voltage)
Q <sub>n-</sub>	Output channel n (current or voltage)
U <sub>An</sub>	Actuator supply voltage, channel n

## Article numbers

### I/O devices

Table B- 1 I/O devices: Article numbers

Designation	Article number
<b>Digital input devices</b>	
8 DI DC 24V 4×M12	6ES7141-6BF00-0AB0
8 DI DC 24V 8×M12	6ES7141-6BG00-0AB0
16 DI DC 24V 8×M12	6ES7141-6BH00-0AB0
<b>Digital output devices</b>	
8 DO DC 24V/1,3A 4×M12	6ES7142-6BF00-0AB0
8 DO DC 24V/0,5A 4×M12	6ES7142-6BF50-0AB0
8 DO DC 24V/1,3A 8×M12	6ES7142-6BG00-0AB0
8 DO DC 24V/2,0A 8×M12	6ES7142-6BR00-0AB0
16 DO DC 24V/1,3A 8×M12	6ES7142-6BH00-0AB0
<b>Digital input/digital output device</b>	
8 DIO DC 24V/1,3A 8×M12	6ES7147-6BG00-0AB0
<b>Analog input device</b>	
8 AI 4 U/I + 4 RTD/TC 8×M12	6ES7144-6KD00-0AB0
8 AI RTD/TC 8×M12	6ES7144-6KD50-0AB0
<b>Analog output device</b>	
4 AO U/I 4×M12	6ES7145-6HD00-0AB0
<b>IO-Link master</b>	
4 IO-L + 8 DI + 4 DO DC 24V/1,3A 8×M12	6ES7148-6JA00-0AB0
4 IO-L 4×M12	6ES7148-6JD00-0AB0



## Accessories for I/O devices

Table B- 2 Accessories for I/O devices: Article numbers

Designation		Article number
<b>Accessories</b>		
Voltage distributor PD DC 24V 1x7/8" 4xM12		6ES7148-6CB00-0AA0
Terminal block		6ES7194-6CA00-0AA0
Mounting rail, 500 mm		6ES7194-6GA00-0AA0
Profile screws, 50 items		6ES7194-6MA00-0AA0
M12 cover caps 10 items/package, 10 items		3RX9802-0AA00
M12 cover caps AS-Interface 10 items/package, 10 items		3RK1901-1KA00
Labels 10 x 7 mm, pale turquoise, 816 items per pack		3RT1900-1SB10
<b>Accessories for the interface "PROFINET M12 connector X1 P1 R or X1 P2 R LAN"</b>		
<b>Raw cables and connectors</b>		
PROFINET M12 connector d coded with FastConnect connection system, 180°	1 item per pack	6GK1901-0DB10-6AA0
	8 items per pack	6GK1901-0DB10-6AA8
PROFINET M12 connector d-coded with FastConnect connection system, 180°	1 item per pack	6GK1901-0DB20-6AA0
	8 items per pack	6GK1901-0DB20-6AA8
PROFINET M12 connector d-coded, angled		3RK1902-2DA00
PROFINET FC cable		
• FC TP Standard Cable		6XV1840-2AH10
• FC TP Trailing Cable		6XV1840-3AH10
• FC TP Trailing Cable GP		6XV1870-2D
• FC TP Marine Cable		6XV1840-4AH10
• FC TP Torsion Cable		6XV1870-2F
• FC TP Flexible Cable GP		6XV1870-2B
• FC TP FRNC Cable		6XV1871-2F
• FC TP Food Cable		6XV1871-2L
• FC TP Festoon Cable GP		6XV1871-2S

Designation	Article number	
<b>Preassembled cable</b>		
PROFINET M12 connecting cable Trailable cable <ul style="list-style-type: none"> <li>Preassembled with M12 connectors 180°, fixed lengths, 1 unit</li> </ul>	0.3 m	6XV1870-8AE30
	0.5 m	6XV1870-8AE50
	1.0 m	6XV1870-8AH10
	1.5 m	6XV1870-8AH15
	2.0 m	6XV1870-8AH20
	3.0 m	6XV1870-8AH30
	5.0 m	6XV1870-8AH50
	10.0 m	6XV1870-8AN10
	15.0 m	6XV1870-8AN15
PROFINET M12 connecting cable Trailable cable <ul style="list-style-type: none"> <li>Preassembled with M12 connectors, angled, fixed lengths, 1 unit</li> </ul>	0.3 m	6XV1870-8GE30
	0.5 m	6XV1870-8GE50
	1.0 m	6XV1870-8GH10
	1.5 m	6XV1870-8GH15
	2.0 m	6XV1870-8GH20
	3.0 m	6XV1870-8GH30
	5.0 m	6XV1870-8GH50
	10.0 m	6XV1870-8GN10
	15.0 m	6XV1870-8GN15
PROFINET M12 connecting cable Trailable cable <ul style="list-style-type: none"> <li>Preassembled with M12 connector at one end (one end with pin, one end open), fixed lengths, 1 item:</li> </ul>	3.0 m	3RK1902-2HB30
	3.0 m	3RK1902-2HB50
	10.0 m	3RK1902-2HC10
PROFINET M12 connecting cable Trailable cable <ul style="list-style-type: none"> <li>Preassembled at one end with M12 connector 180° (pin), other side with RJ45 plug 145°, fixed lengths, 1 item</li> </ul>	2.0 m	6XV1871-5TH20
	3.0 m	6XV1871-5TH30
	5.0 m	6XV1871-5TH50
	10.0 m	6XV1871-5TN10
	15.0 m	6XV1871-5TN15
IE FC Robust Food Cable GP 2x2 <ul style="list-style-type: none"> <li>Preassembled at both ends with M12 connectors (d-coded), 1 unit</li> </ul>	1.0 m	6XV1881-5AH10
	2.0 m	6XV1881-5AH20
	3.0 m	6XV1881-5AH30
	5.0 m	6XV1881-5AH50
Y-cable for connection of two I/Os, 5-pole M12, 200 mm		6ES7194-6KA00-0XA0
<b>Accessory for the interface "M12-socket X1 to X4/X8"</b>		
<b>Non-converted connector</b>		
M12 connector, 5-pole, screw-type terminal, max. 0.75 mm <sup>2</sup> , A-coded, max. 4 A, 1 unit	3RK1902-4BA00-5AA0	
M12 connector angled, 5-pole, screw-type terminal, max. 0.75 mm <sup>2</sup> , A-coded, max. 4 A, 1 unit	3RK1902-4DA00-5AA0	
M12 plug-in cables, shielded, for connecting digital and analog sensors and actuators	(on request)	

Designation	Article number	
<b>Preassembled cables and connectors</b>		
Connecting cable M12-M12, 3-pin, PUR cable, 3 × 0.34 mm <sup>2</sup> , Type E, L, IP67, NO, straight female connector M12 to straight male connector M12	1.5 m	3RK19024PB15-3AA0
M12 connecting cables (PUR sheath), A-coded, max. 4 A • Preassembled at both ends, 3 x 0.34 mm <sup>2</sup> , fixed lengths, 1 item	1.5 m	3RK1902-4PB15-3AA0
	5.0 m	6GT2891-4MH50
	10.0 m	6GT2891-4MH10
M12 connecting cables (PUR sheath), A-coded, max. 4 A • Preassembled with M12 connector at one end, angled (one end with socket, one end open), 5 x 0.35 mm <sup>2</sup> , fixed lengths, 1 item	1.5 m	3RK1902-4HB15-5AA0
	5 m	3RK1902-4HB50-5AA0
	10 m	3RK1902-4HC01-5AA0
M12 compensation connector for thermocouples	6ES7194-4AB00-0AA0	
<b>Accessories for the interface "DC 24 V IN/OUT M12 (X02/X03)"</b>		
<b>Raw cables and connectors</b>		
IE Power M12 Cable Connector PRO, plug-in connector for connection to PS791-1PRO power supply for 24 V DC supply voltage with mounting instructions, 4-pin, A-coded, 3 units	6GK1907-0DB10-6AA3	
IE Power M12 Cable Connector Pro, connection socket for connecting SCALANCE W-700/X208PRO for 24 V DC supply voltage with mounting instructions, 4-pin, A-coded, 3 items	6GK1907-0DC10-6AA3	
Power M12 connector angled, 4-pole, screw-type terminal, max. 0.75 mm <sup>2</sup> , A-coded, max. 4 A, 1 unit	3RK1902-4CA00-4AA0	
Power M12 connector angled, 5-pole, screw-type terminal, max. 0.75 mm <sup>2</sup> , A-coded, max. 4 A, 1 unit	3RK1902-4DA00-5AA0	
<b>Preassembled cables and connectors</b>		
Power Connecting Cable M12-180/M12-180 for power supply of the ET 200, preassembled cable with M12 connector and M12 socket, A-coded, 5-pin	0.3 m	6XV1801-5DE30
	0.5 m	6XV1801-5DE50
	1.0 m	6XV1801-5DH10
	1.5 m	6XV1801-5DH15
	2.0 m	6XV1801-5DH20
	3.0 m	6XV1801-5DH30
	5.0 m	6XV1801-5DH50
	10.0 m	6XV1801-5DN10
Power Connecting Cable M12-90/M12-90 for power supply of the ET 200, preassembled cable with M12 connector and M12 socket, A-coded, 5-pin	0.3 m	6XV1801-5GE30
	0.5 m	6XV1801-5GE50
	1.0 m	6XV1801-5GH10
	1.5 m	6XV1801-5GH15
	2.0 m	6XV1801-5GH20
	3.0 m	6XV1801-5GH30
	5.0 m	6XV1801-5GH50
	10.0 m	6XV1801-5GN10
Robust Power Connecting Cable M12-180/M12-180 for power supply of the ET 200, preassembled cable with M12 connector and M12 socket, A-coded, 5-pin	1.0 m	6XV1801-5AH10
	2.0 m	6XV1801-5AH20
	3.0 m	6XV1801-5AH30
	5.0 m	6XV1801-5AH50

## Accessories for voltage distributors

Table B- 3 Accessories for voltage distributors: Article numbers

Designation	Article number	
<b>Accessories for the interface "DC 24V IN 7/8" (X05)"</b>		
<b>Raw cables and connectors</b>		
7/8" connector with axial cable exit for field assembly ET 200, socket insert	6KG1905-0FB00	
7/8" connector (screw mechanism), angled, socket insert, 5 items/package	3RK1902-3DA00	
Energy Cable Trailable power cable, 5 x 1.5 mm <sup>2</sup> Sold by meter, min. ordering quantity 20 m, Delivery unit max. 1000 m, 1 m	6XV1830-8AH10	
<b>Preassembled cables and connectors</b>		
Power Connecting Cable M12-180/M12-180 for power supply of the ET 200, preassembled cable with M12 connector and M12 socket, A-coded, 5-pin	0.3 m	6XV1801-5DE30
	0.5 m	6XV1801-5DE50
	1.0 m	6XV1801-5DH10
	1.5 m	6XV1801-5DH15
	2.0 m	6XV1801-5DH20
	3.0 m	6XV1801-5DH30
	5.0 m	6XV1801-5DH50
	10.0 m	6XV1801-5DN10
	15.0 m	6XV1801-5DN15
Power Connecting Cable M12-90/M12-90 for power supply of the ET 200, preassembled cable with M12 connector and M12 socket, A-coded, 5-pin	0.3 m	6XV1801-5GE30
	0.5 m	6XV1801-5GE50
	1.0 m	6XV1801-5GH10
	1.5 m	6XV1801-5GH15
	2.0 m	6XV1801-5GH20
	3.0 m	6XV1801-5GH30
	5.0 m	6XV1801-5GH50
	10.0 m	6XV1801-5GN10
	15.0 m	6XV1801-5GN15
Robust Power Connecting Cable M12-180/M12-180 for power supply of the ET 200, preassembled cable with M12 connector and M12 socket, A-coded, 5-pin	1.0 m	6XV1801-5AH10
	2.0 m	6XV1801-5AH20
	3.0 m	6XV1801-5AH30
	5.0 m	6XV1801-5AH50
7/8" connecting cable for power supply of the ET 200, preassembled cable with 7/8" connectors 180° at both sides (one side female connector, one side male connector), 5-pole	0.3 m	6XV1822-5BE30
	0.5 m	6XV1822-5BE50
	1.0 m	6XV1822-5BH10
	1.5 m	6XV1822-5BH15
	2.0 m	6XV1822-5BH20
	3.0 m	6XV1822-5BH30
	5.0 m	6XV1822-5BH50
	10.0 m	6XV1822-5BN10
	15.0 m	6XV1822-5BN15

Designation		Article number
7/8" connecting cable for power supply of the ET 200, preassembled cable with 7/8" connectors angled at both sides (one side female connector, one side male connector), 5-pole	1.5 m	6XV1822-5BH15-OSB0*
	2.0 m	6XV1822-5BH20-OSB0*
	3.0 m	3RK1902-3NB30
	5.0 m	3RK1902-3NB50
	10.0 m	3RK1902-3NC10
	15.0 m	6XV1822-5BN15-OSB0*
7/8" connecting cable for power supply of the ET 200, preassembled at one side with 7/8" connector angled (one side female connector, one side male connector), 5-pole	3.0 m	3RK1902-3GB30
	5.0 m	3RK1902-3GB50
	10.0 m	3RK1902-3GC10

\* Order via Org-ID 10001539

## Spare parts

Table B- 4 Spare parts: Article numbers

Designation	Article number
Spare fuses for terminal block (Miniature copper flat fuse, type FK1, 7.5 A, fast-blow), 10 pieces	6ES7194-6HB00-0AA0

## PROFINET IO

Technical book	Contents	Article number
Automating with PROFINET - Industrial Communication based on Industrial Ethernet	This book provides an introduction to the new PROFINET technology	Commercial book number: ISBN 3-89578-244-0

## SIMATIC Manual Collection

Designation	Contents	Article number
SIMATIC Manual Collection	Contains all SIMATIC manuals in electronic format	6ES7998-8XC01-8YE0

## Technical Product Data - CD ROM

Designation	Contents	Article number
Technical Product Data for CAx Applications	Contains the following technical product data for CAD/CAE systems: <ul style="list-style-type: none"> <li>• Technical specifications according to ECAD component standard V1.2</li> <li>• Graphical data (drawings)</li> <li>• Circuit-diagram macros</li> </ul>	6ES7991-0CC00-0YX0

## Dimensional drawings

### C.1 Dimensional drawings

#### Dimensional drawing of the I/O devices of 30 mm width

The figure shows the dimensional drawing of the I/O devices:

- 8 DI DC 24V 4×M12
- 8 DO DC 24V/1,3A 4×M12
- 8 DO DC 24V/0,5A 4×M12
- 4 IO-L 4×M12

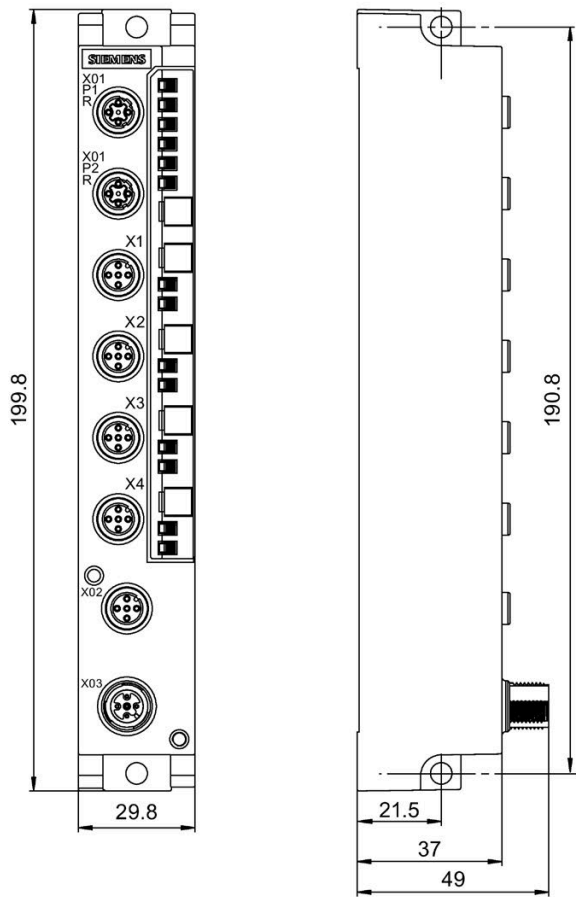

### Dimensional drawing of the I/O devices of 60 mm width

The figure shows the dimensional drawing of the I/O devices:

- 8 DI DC 24V 8×M12 (current figure)
- 16 DI DC 24V 8×M12
- 8 DO DC 24V/1,3A 8×M12
- 8 DO DC 24V/2,0A 8×M12
- 16 DO DC 24V/1,3A 8×M12
- 8 DIO DC 24V/1,3A 8×M12
- 8 AI 4 U/I + 4 RTD/TC 8×M12
- 8 AI RTD/TC 8×M12
- 4 IO-L + 8 DI + 4 DO DC 24V/1,3A 8×M12

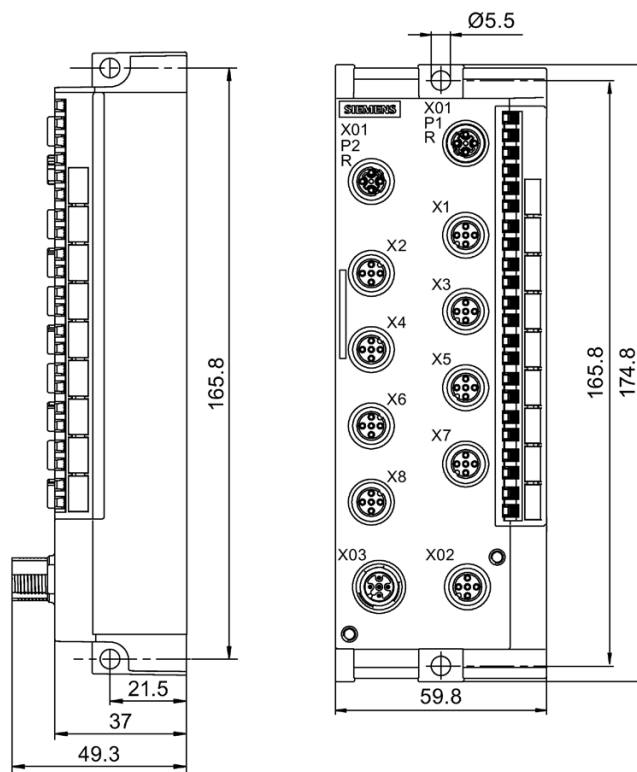



### Dimensional drawing of the I/O devices of 60 mm width (with 4 I/O connectors)

The figure shows the dimensional drawing of the I/O devices:

- 4 AO U/I 4xM12

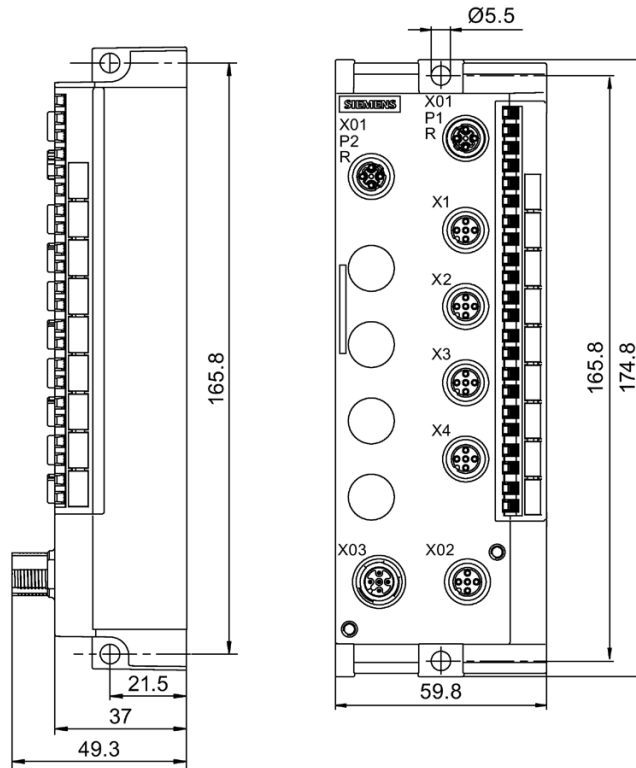

### Dimensional drawing of the voltage distributor

The figure shows the dimensional drawing of the voltage distributor  
PD DC 24V 1×7/8" 4×M12

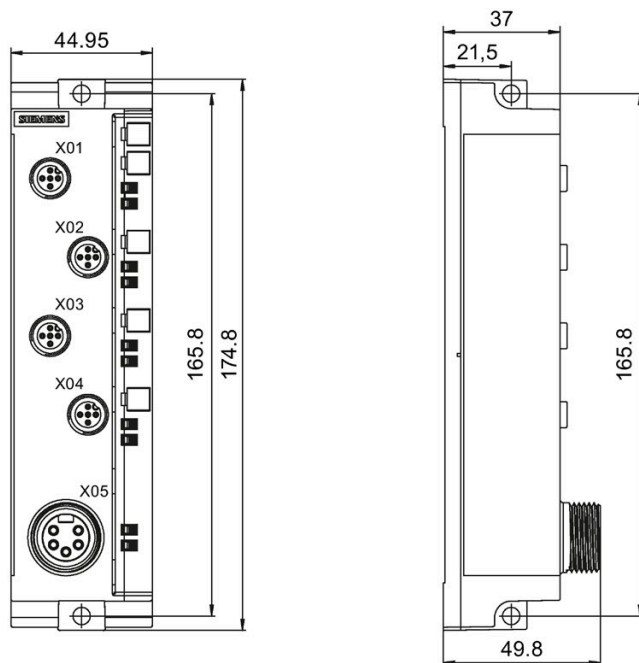

### Dimensional drawing of the terminal block

The figure shows the dimensional drawing of the terminal block:

- Separately
- Installed on an I/O device

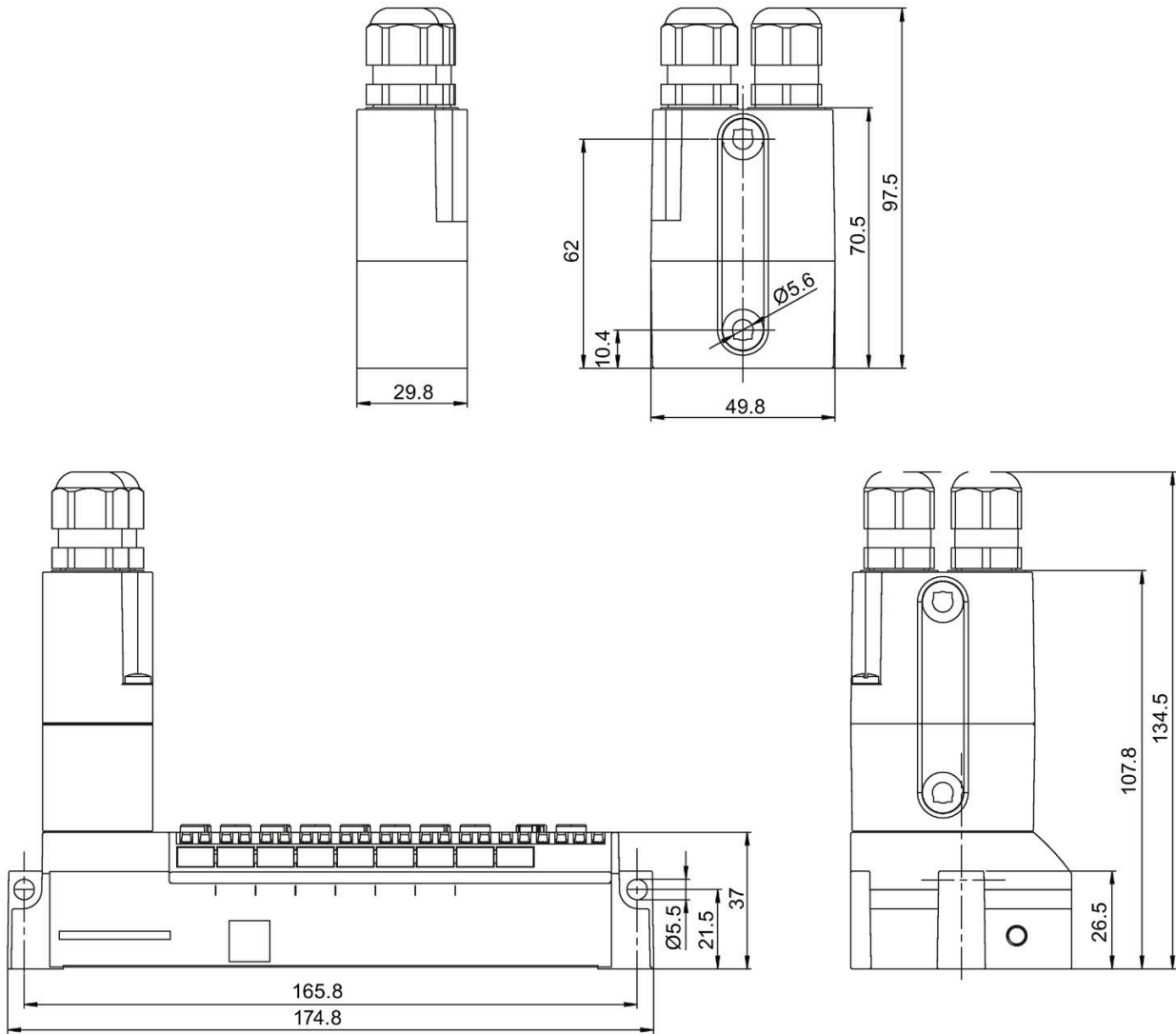

### Dimensional drawing of the mounting rail

The figure shows the dimensional drawing of the mounting rail:

- Separately
- with an I/O device of 30 mm width
- with an I/O device of 60 mm width

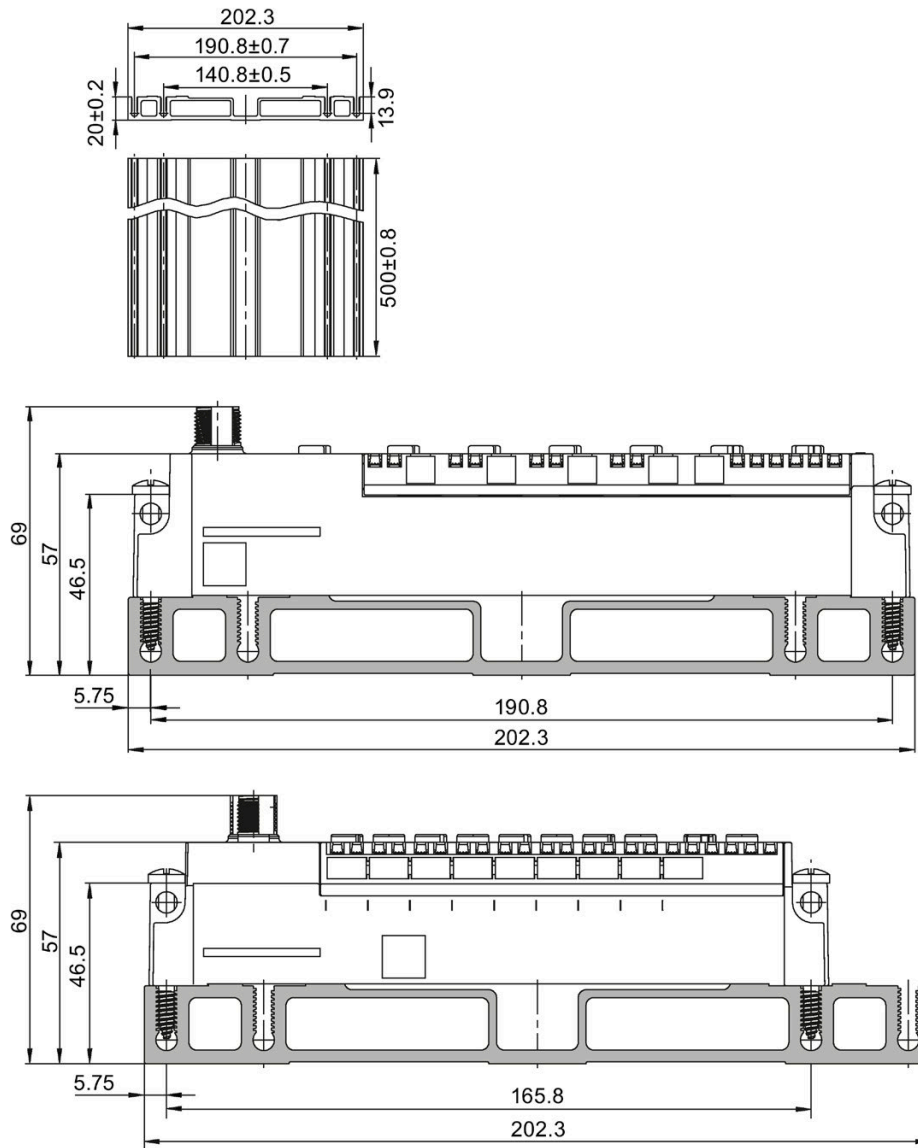

## Connection examples

### D.1 Connection of resistance thermometers to the analog inputs

#### Connection example 8 AI RTD/TC 8xM12

The figure below shows connection examples for 2-, 3- and 4-conductor connections.

2-conductor

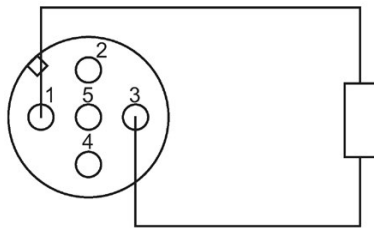

3-conductor

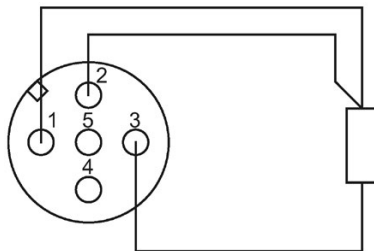

4-conductor

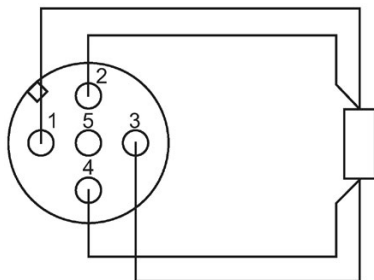

Figure D-1 Connection examples: 2-, 3- and 4-conductor

## D.2 Connection of thermocouples to the analog inputs

### Introduction

Different options are available for the analog I/O device 8 AI RTD/TC 8xM12 for compensation of the reference junction temperature. The corresponding connection examples are shown below. In practice, different connection variants may be possible due to the conditions on site.

### Connection example "No" compensation as reference junction

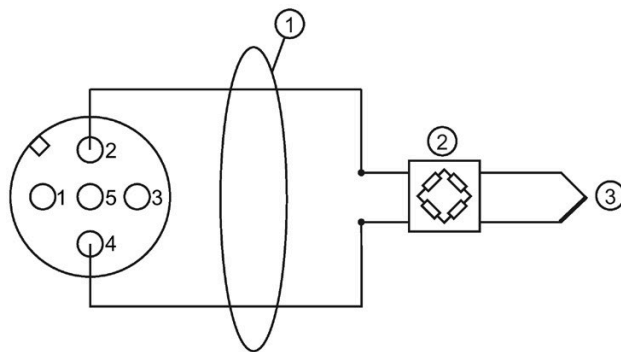

- ① Copper cables
- ② e. g. compensating box (per channel); thermocouple type B does not need a compensating box
- ③ Thermocouple

Figure D-2 Connection example "No" compensation as reference junction

### Connection example "Internal" compensation or "Fixed reference temperature" as reference junction

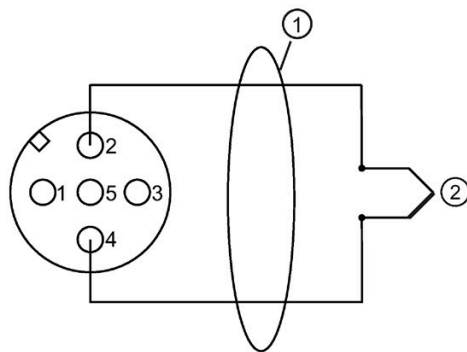

- ① Direct connection of the thermocouple or with compensating lines
- ② Thermocouple

Figure D-3 Connection example "Internal" compensation or "Fixed reference temperature" as reference junction

### Connection example "RTD (0)" as reference junction

- With M12 compensation connector (integrated resistance thermometer Pt1000)

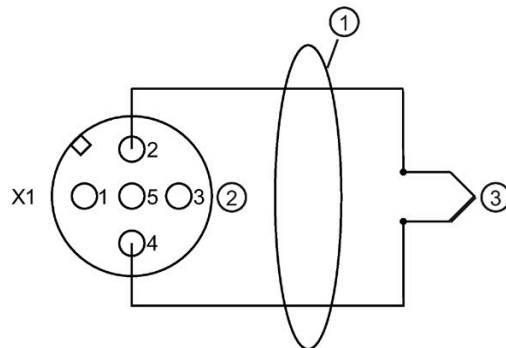

- ① Direct connection of the thermocouple or with compensating lines
- ② M12 compensation connector (terminals 1 and 3 assigned with internal Pt1000) only on round socket X1. The comparison value of the M12 compensation connector at round socket X1 also applies to thermocouples at X2, X3, X4, X5, X6, X7 and X8.
- ③ Thermocouple

Figure D-4 Connection example "RTD (0)" as reference junction in M12 compensation connector

- With external resistance thermometer Pt1000

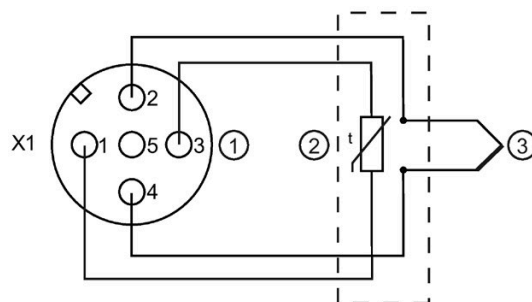

- ① M12 connector only on round socket X1
- ② External Pt1000 ( $\alpha = 0.003851$ ) in the area of the reference junction with copper cables at terminals 1 and 3. The comparison value of the external Pt1000 at round socket X1 also applies to thermocouples at X2, X3, X4, X5, X6, X7 and X8.
- ③ Thermocouple

Figure D-5 Connection example "RTD (0)" as reference junction with external Pt1000

Connection example "Dynamic reference temperature" as reference junction

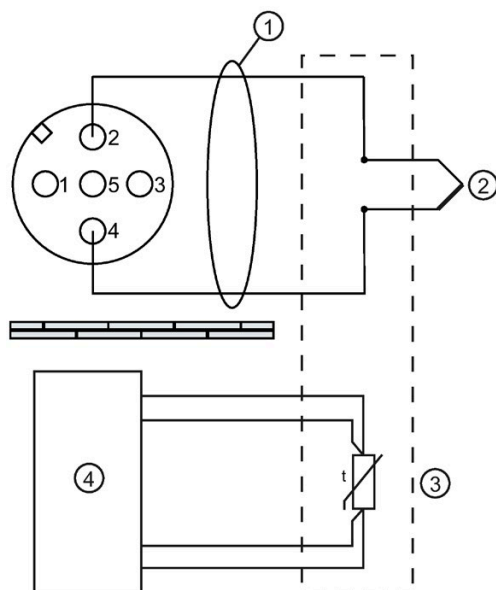

- ① Copper cables
- ② Thermocouple at 8 AI RTD/TC 8xM12
- ③ e. g. Pt100 in the area of the reference junction
- ④ RTD module of another station

Figure D-6 Connection example "Dynamic reference temperature" as reference junction



## I/O address space

### I/O device 8 DI DC 24V 4xM12

Assignment in the process image inputs per device:

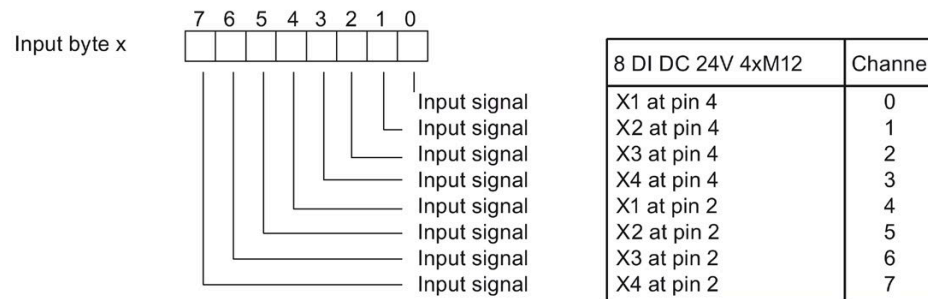

Figure E-1 Address space of 8 DI DC 24V 4xM12 I/O device

### I/O device 8 DI DC 24V 8xM12

Assignment in the process image inputs per device:

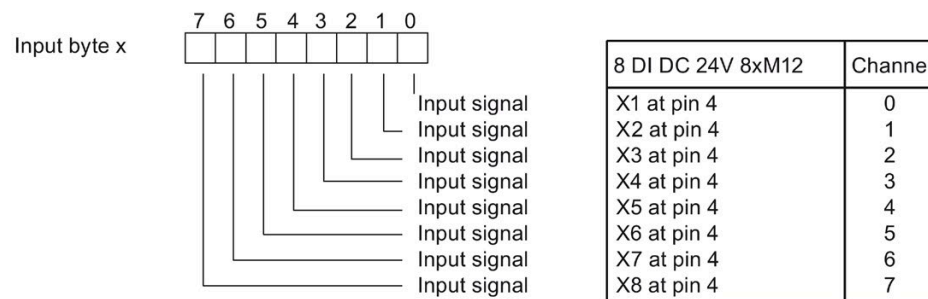

Figure E-2 Address space of 8 DI DC 24V 8xM12 I/O device

### I/O device 16 DI DC 24V 8xM12

Assignment in the process image inputs per device:

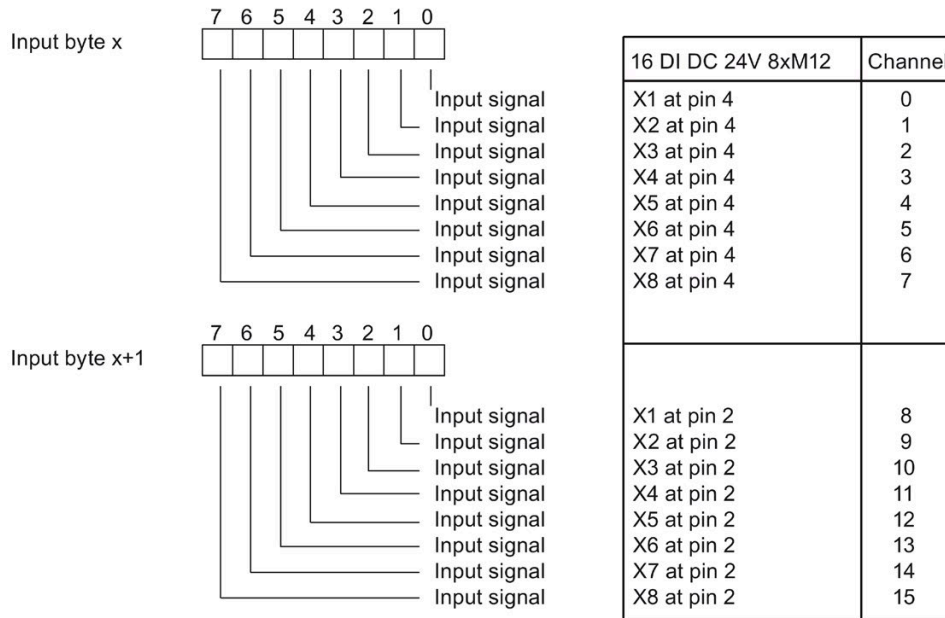

Figure E-3 Address space of 16 DI DC 24V 8xM12 I/O device

### I/O device 8 DO DC 24V/1,3A 4xM12

Assignment in the process image output per device:

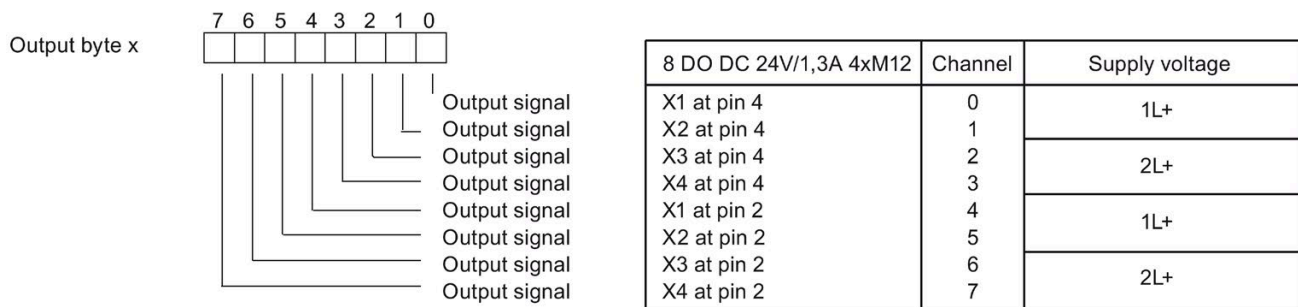

Figure E-4 Address space of 8 DO DC 24V/1,3A 4xM12 I/O device

**I/O device 8 DO DC 24V/0,5A 4xM12**

Assignment in the process image output per device:

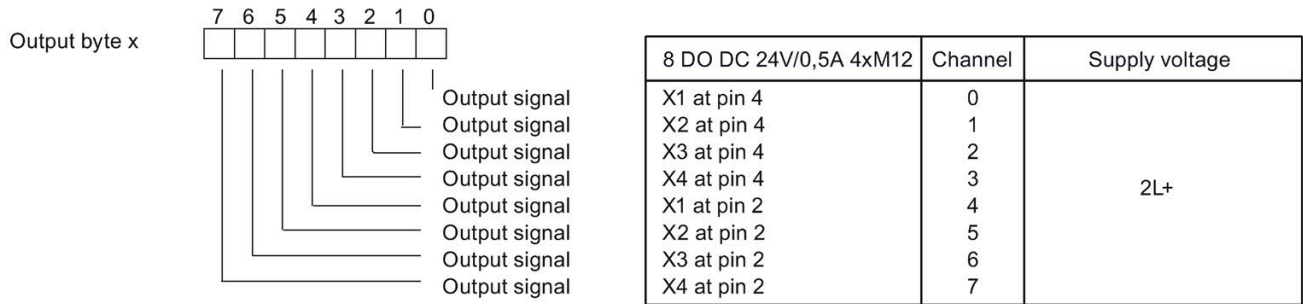

Figure E-5 Address space of 8 DO DC 24V/0,5A 4xM12 I/O device

**I/O device 8 DO DC 24V/1,3A 8xM12 and 8 DO DC 24V/2,0A 8xM12**

Assignment in the process image output per device:

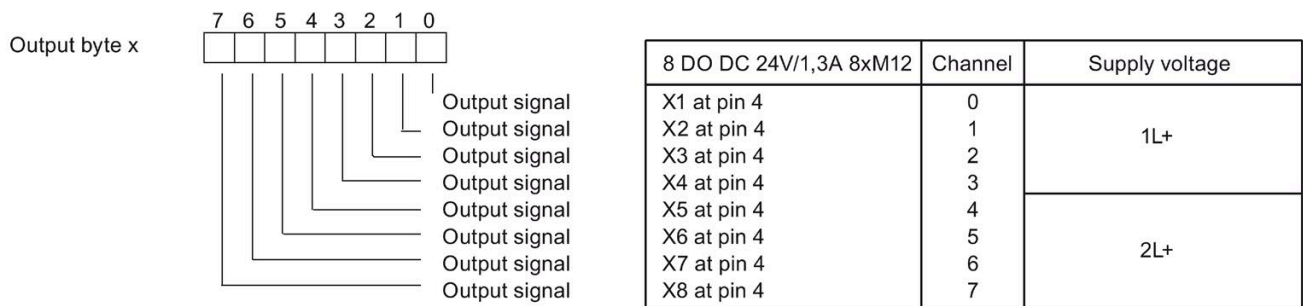

Figure E-6 Address space of I/O device 8 DO DC 24V/1,3A 8xM12 and 8 DO DC 24V/2,0A 8xM12

### I/O device 16 DO DC 24V/1,3A 8xM12

Assignment in the process image output per device:

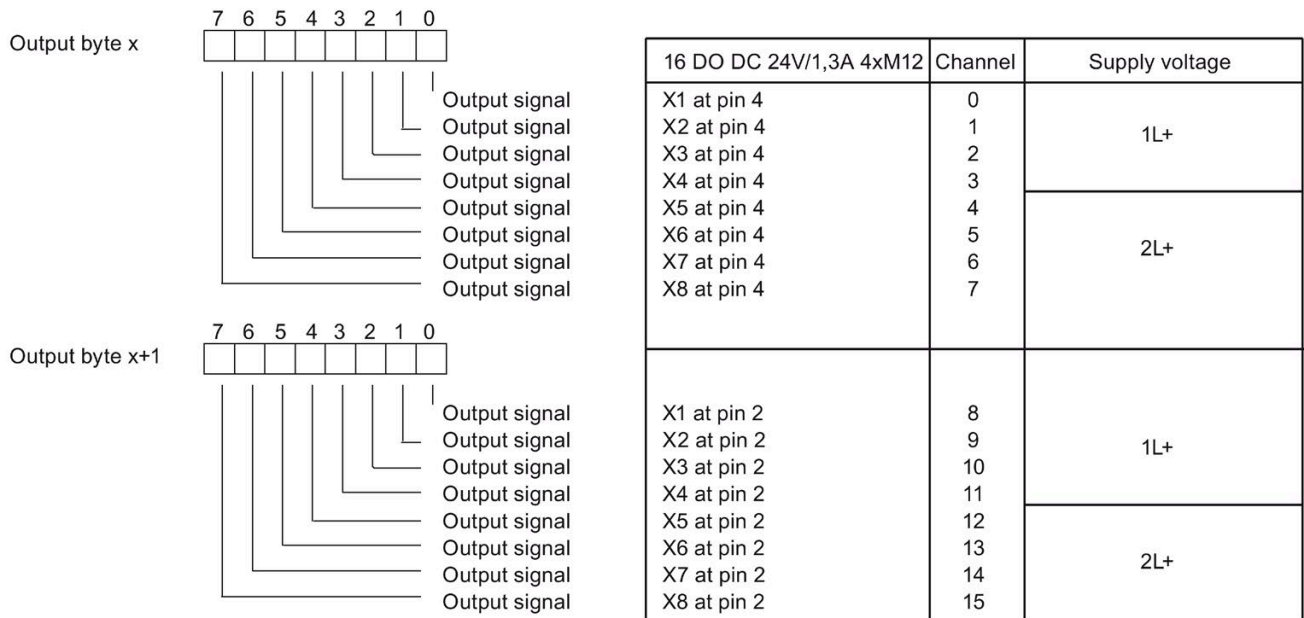

Figure E-7 Address space of 16 DO DC 24V/1,3A 8xM12 I/O device

### I/O device 8 DIO DC 24V/1,3A 8xM12

Assignment in the process image inputs per device:

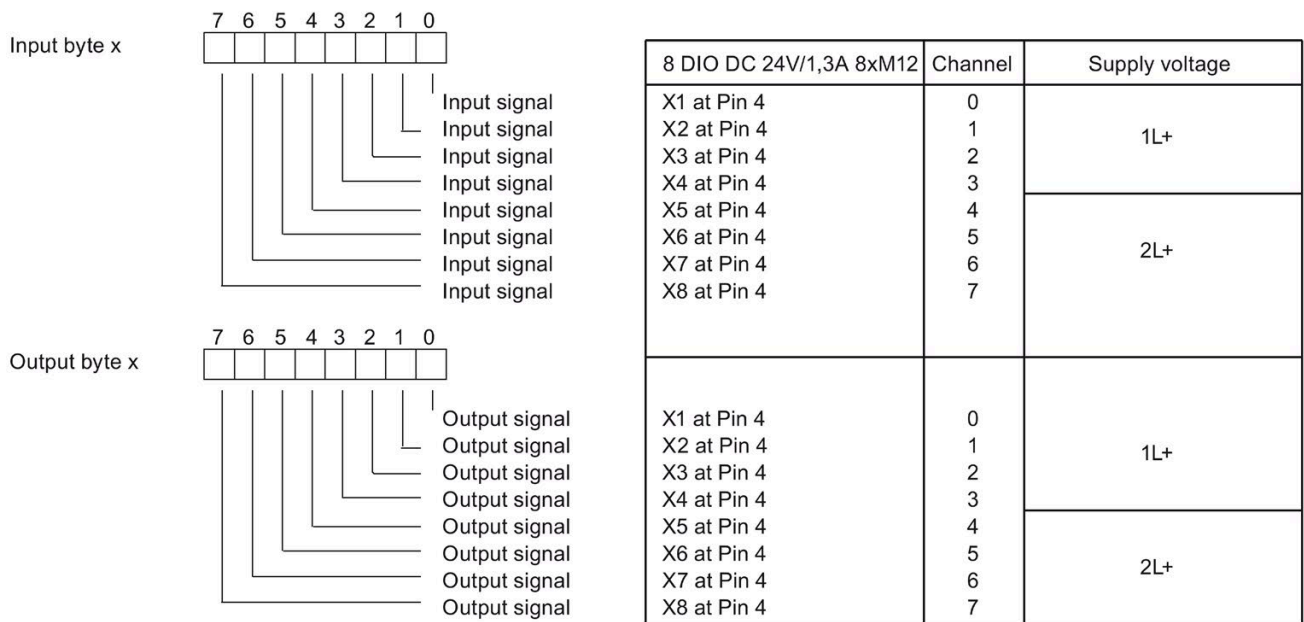

Figure E-8 Address space of 8 DIO DC 24V/1,3A 8xM12 I/O device

**I/O device 8 AI 4 U/I + 4 RTD/TC 8×M12**

Assignment in the process image inputs per device:

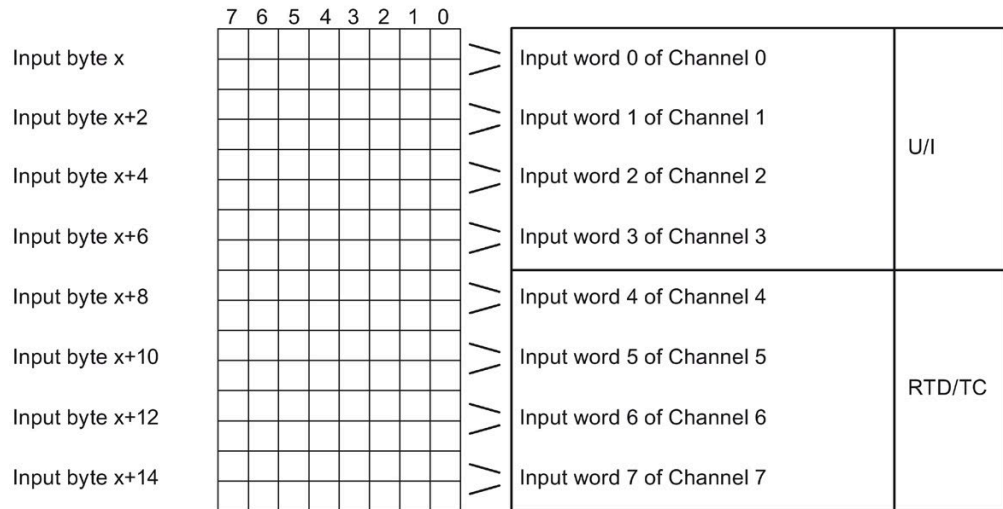

Figure E-9 Address space of 8 AI 4 U/I + 4 RTD/TC 8×M12 I/O device

**I/O device 8 AI RTD/TC 8×M12**

Assignment in the process image inputs per device:

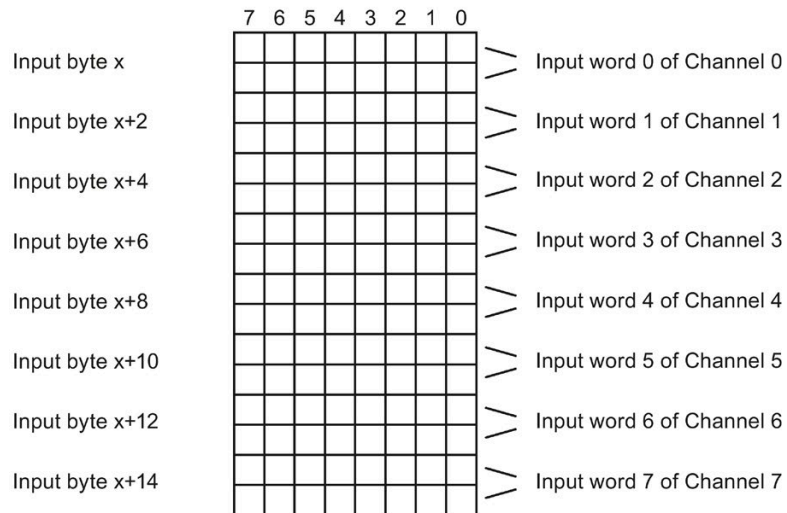

Figure E-10 Address space of 8 AI RTD/TC 8×M12 I/O device

### I/O device 4 AO UI 4xM12

Assignment in the process image output per device:

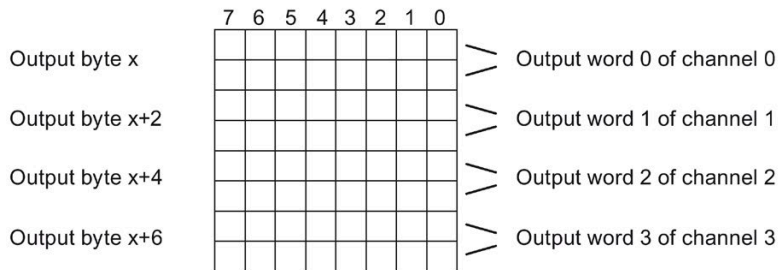

Figure E-11 Address space of 4 AO UI 4xM12 I/O device

### IO-Link Master 4 IO-L + 8 DI + 4 DO DC 24V/1,3A 8xM12

During the STEP 7 configuration, you can select the address space according to use.

During GSD configuration, Slot 1 "4 IO-L" has fixed 32 bytes input and 32 bytes output. Addressing of the input and output data can be selected freely using *S7-PCT*.

**Note**

**Value status (PortQualifier)**

The value status (PortQualifier) is disabled by default. An active value status (PortQualifier) is generally at byte x, bit 0 to bit 3. It can also be placed freely within the address space (byte x to x+32).

Assignment of the inputs and IO-Link channels as an example:

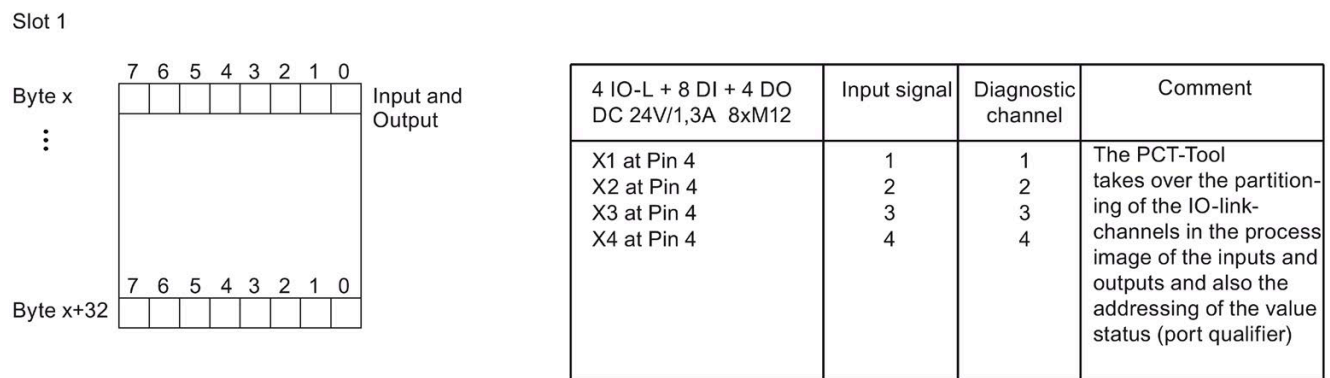

Figure E-12 Address space of the IO-Link channels of the IO-Link Master 4 IO-L + 8 DI + 4 DO DC 24V/1,3A 8xM12

Slot "8 DI + 4DO" has its own address space. The scope amounts to one byte inputs and one byte outputs.

Slot 2

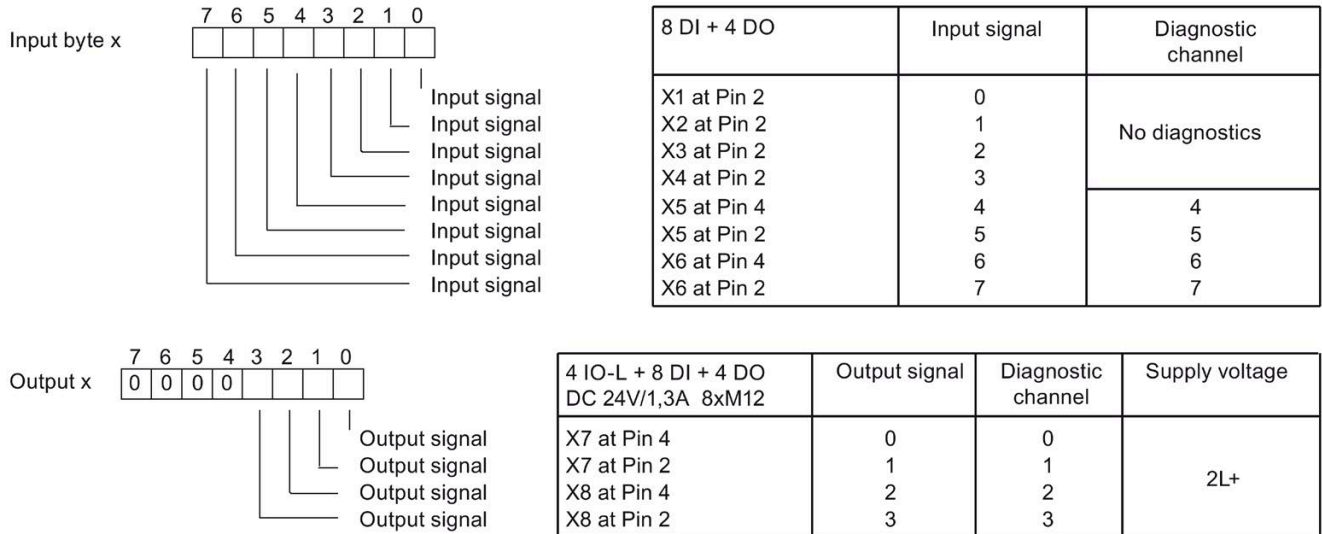

Figure E-13 Address space of the inputs and outputs of the IO-Link Master 4 IO-L + 8 DI + 4 DO DC 24V/1,3A 8xM12

## IO-Link Master 4 IO-L 4xM12

During the configuration, you can select the address space according to use.

### SIO mode

The following figures show the assignment of the address spaces of a submodule/port with the IO-Link Master 4 IO-L 4xM12, if you have configured the port as digital input or digital output in SIO mode.

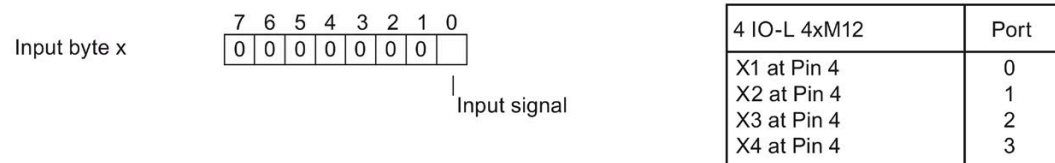

Figure E-14 Address space of the inputs of the IO-Link Master 4 IO-L 4xM12 in SIO mode

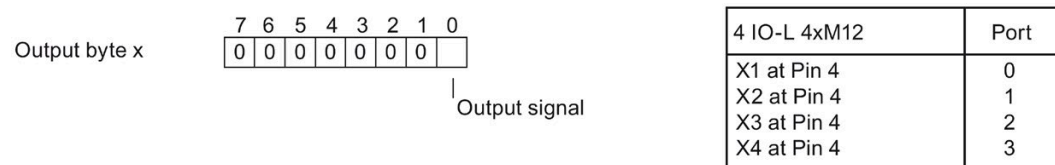
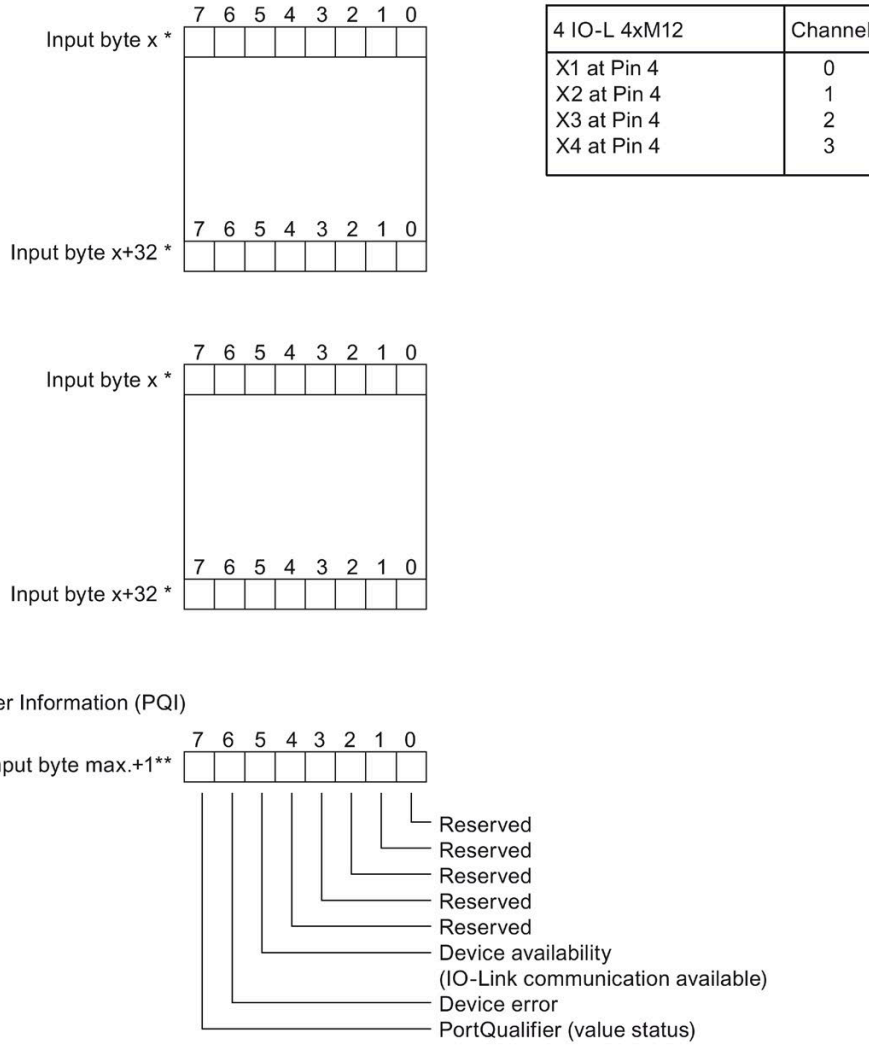

Figure E-15 Address space of the outputs of the IO-Link Master 4 IO-L 4xM12 in the SIO mode

### IO-Link mode

The following figure shows the assignment of the address spaces of a submodule/port with the IO-Link Master 4 IO-L 4xM12, if you have configured the port in IO-Link mode.



\* Detailed information on the assignment of the input and output bytes is available in the description of the IO-Link devices that are used.

\*\* The PQI byte is always located behind the last input byte of the port. Depending on the configuration, the PQI byte is thus at byte 2, 3, 5, 9, 17 or 33 in the process input image.

Figure E-16 Address space of the inputs and outputs and of the PQI byte of the IO-Link Master 4 IO-L 4xM12 in IO-Link mode



# Response times for analog input device and output device

# F

## F.1 Response times for analog input device

### Conversion time

The basic conversion time depends directly on the conversion method of the analog input channel (integrating method, instantaneous value conversion). For the integrating conversion method, the integration time is included directly in the conversion time. The integration time depends on the interference frequency suppression.

For information on the basic conversion times and additional processing times of the individual analog devices, refer to the technical data of the corresponding analog I/O device.

### Cycle time

The analog-digital conversion and the transfer of the digitized measured values to memory or to the backplane bus take place sequentially. In other words, the analog input channels are converted one after the other. The cycle time, that is, the time until an analog input value is converted again, is the sum of the conversion times of all the activated analog input channels of the analog input devices. You should deactivate unused analog input channels during parameter assignment in order to reduce the cycle time. The conversion and integration time for a deactivated channel is 0.

The figure below provides an overview of the cycle time elements of an n-channel analog input device.

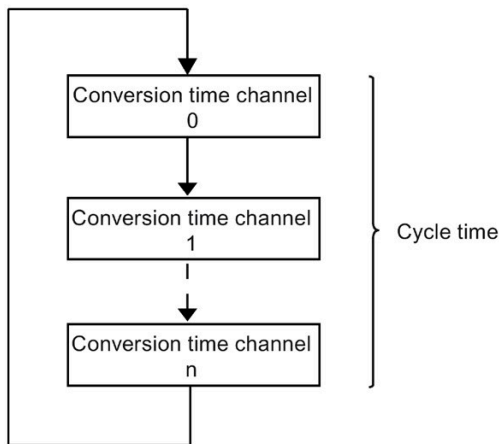

Figure F-1 Cycle time for analog input devices

### Settling time

See *Smoothing*.

## F.2 Response times for analog output device

### Conversion time

The conversion time of the analog output channels includes the transfer of digitized output values from internal memory, and their digital-to-analog conversion.

### Cycle time

The analog output channels are converted for the device with an execution time plus the sequential conversion time for channels 0, 1, 2, and 3.

The cycle time, i.e., the time until an analog output value is converted again, is the sum of the conversion times of all the activated analog output channels and of the processing time of the analog output device. You should deactivate unused analog output channels during parameter assignment in order to reduce the cycle time. The conversion time for a deactivated channel is 0 ms.

The following figure provides you with an overview of the cycle time elements for an analog output device.

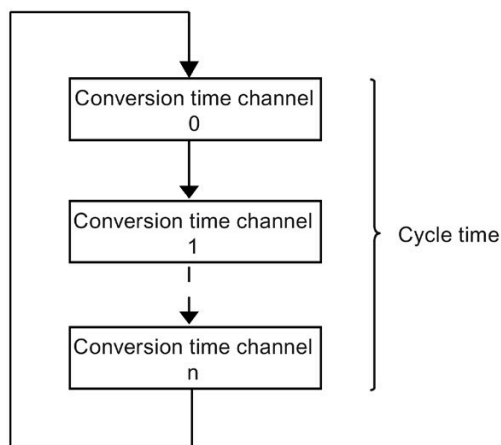

Figure F-2 Cycle time of analog output modules

### Settling time

The settling time ( $t_2$  to  $t_3$ )—that is, the time from the application of the converted value until the specified value is reached at the analog output—depends on the load. We therefore distinguish between resistive, capacitive, and inductive loads.

## Response time

The response time ( $t_1$  to  $t_3$ )—that is, the time from the application of the digital output values in internal memory until the specified value is reached at the analog output—is, in the most unfavorable case, the sum of the cycle time and the settling time. The worst case scenario is when the analog channel has been converted immediately before a new output value is transferred and is not converted again until all other channels have been converted (cycle time).

This figure shows the response time of an analog output channel:

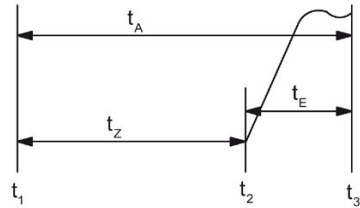

- $t_A$  Response time
- $t_z$  Cycle time, corresponding to the processing time of the device and the conversion time of the channel
- $t_E$  Settling time
- $t_1$  New digital output value applied
- $t_2$  Output value transferred and converted
- $t_3$  Specified output value obtained

Figure F-3 Response time of an analog output channel

# Fail-safe shutdown of ET 200eco PN standard modules



## G.1 Back-up oriented shutdown of ET 200eco PN standard modules

### Introduction

The following structure describes how to perform a fail-safe shutdown of ET 200eco PN standard modules.

In the configuration shown in the diagram below (e.g. with the safety shutdown device 3SK1), all digital outputs that are connected to the 2L+ and 2M supply (24 V switched) of the ET 200eco PN standard modules are switched to the safe OFF state. This step achieves the safety class SIL2/category 3/PL d.

### Principle of operation

The higher-level safety shutdown device (e.g. 3SK1) disconnects the supply 2L+ and 2M switched. The digital outputs of the ET 200eco PN standard modules operated at the 2L+ and 2M (24 V switched) supply are switched to the safe state. The digital outputs connected to the supply 1L+ and 1M (24 V non-switched) are not intended for switching under normal operating conditions and cannot be safely shutdown.

There is no opposite influence of the outputs.

 **WARNING**

**Pay attention to the potential groups**

When a digital output is connected to a digital input, pay attention to the respective potential groups. Depending on the configuration, 1M and 2M can then be connected, resulting in elimination of the electrical isolation between 1L+ and 2L+. In this case, a safety-oriented shutdown is not possible.

Block diagram

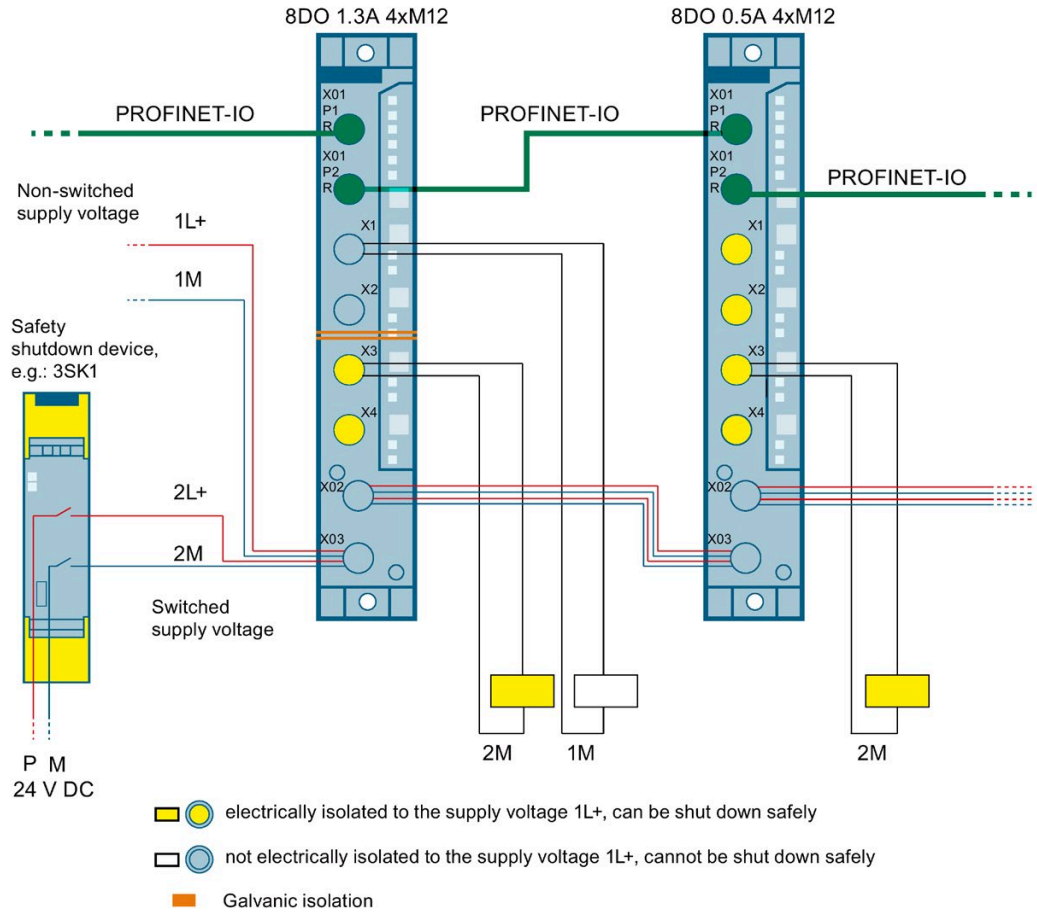

Figure G-1 Higher-level safety shutdown of the outputs

**⚠ WARNING**

When you use a pp-switching safety shutdown device, the power supply cable for connection of the ET 200eco PN modules must be routed cross-circuit proof. Note the requirements of the standard EN 60204-1, "Cross-circuit proof routing".

**Note**

Maintain safe electrical isolation for voltages higher than SELV/PELV.

## Limits of the higher-level safety circuit

The ET 200eco PN standard modules do not fulfill any safety functions. Safety functions are performed by the safety relay or the F-switch to bring the system into a safe state. Adjust the operation inspection interval of the safety relay with relay output according to the safety class.

Take the following measures if energy that is not provided by the higher-level safety circuit is used to control the safety function.

Cover critical errors in the safety function that are not detected by the higher-level safety circuit (e.g. 3SK1, F-switch etc.) with suitable safety measures. The "diagnostics" must be performed indirectly via the controlled process.

Specifications for safety-relevant process data:

- Functionally safe
- Read via fail-safe inputs (e.g. F-DI)
- Fail-safe processing unit (e.g. F-CPU) for issuing commands
- Output through fail-safe outputs (e.g. F-DQ) to control the safety function

## Requirements on the power supply

Operation requires a SELV/PELV power supply to limit overvoltages to L+ and M (24 V). This measure prevents possible errors from the power supply side at the same time.

Select the power supply according to the requirements of the respective operating instructions for the shutdown device or for the ET 200eco PN system.

You can find more information on safe SELV/PELV in the data sheets of the power supplies used.

## FAQ

Read the latest information on safety-related shutdown in the FAQ (<https://support.industry.siemens.com/cs/ww/en/view/39198632>).

In this FAQ, you will find the SIMATIC standard modules that are suitable for safety-related shutdown.

## Request German Technical Inspectorate report (Report no. SN95432T)

You can request copies of the German Technical Inspectorate report at the following address:

SIEMENS AG  
Digital Industries  
DI FA SEA SYS DE AMB  
Postfach 1963  
D-92209 Amberg



# Open Source Software

**For Resellers: In order to avoid infringements of the license conditions by the reseller or the buyer, these notes and conditions and accompanying data carrier – if applicable - have to be forwarded to the buyers.**

**Please note:**

This software is protected under Copyright Laws. Unauthorized usage of this software or parts of it may result in claims for damages and will be prosecuted according to criminal as well as civil law.

This software may only be used by authorized users who have a valid license to use this software. Such a license can have been acquired by entering into a license agreement with a Siemens company or an authorized third party supplier. Please read the license terms and conditions contained in your license agreement carefully before installing and using this software.

The license agreement together with a receipt, invoice or other purchase documentation will serve as proof that you have a valid license to use this software. Please keep such proof of your valid license in order to be able to present it in case of doubt. Any use without such license or outside of the granted scope is explicitly prohibited. If you do not have a valid license, please stop using the software immediately and contact your Siemens Company or your local supplier in order to avoid claims for damages against you or your company.

**License Conditions and Disclaimers for Open Source Software and other Licensed Software**

In the product "ET 200eco PN IO-Link Master 4xM12 - V1.0", Copyright Siemens AG, 2016 (hereinafter "Product"), the following Open Source Software is used either unchanged or in a form that we have modified, and additionally the other License Software noted below:

**Liability for Open Source Software**

Open Source Software is provided free of charge. We are liable for the Product including Open Source Software contained in accordance with the license conditions applicable to the Product. Any liability for use of Open Source Software beyond the program flow intended for the Product is explicitly excluded. Furthermore, any liability for defects resulting from modifications to the Open Source Software by you or third parties is excluded.

We do not provide any technical support for the Product if it has been modified.

**Please note the following license conditions and copyright notices applicable to Open Source Software and other License Software:**

Component	Open Source Software [Yes/No]	Acknowledgements	Copyright Information / File
OpenRTOS - 8.2	No		LICENSE AND COPYRIGHT INFORMATION FOR COMPONENT OPENRTOS - 8.2
TPS-1 FW-Stack - 1.3	No		LICENSE AND COPYRIGHT INFORMATION FOR COMPONENT TPS-1 FW-STACK - 1.3

LICENSE CONDITIONS AND COPYRIGHT NOTICES

Commercial Software: OpenRTOS - 8.2

Enclosed you'll find license conditions and copyright notices applicable for Commercial Software OpenRTOS - 8.2

License conditions:  
- (N/A)

Copyrights:

Copyright (C) 1989, 1991 Free Software Foundation, Inc. 59 Temple Place, Suite 330, Boston, MA 02111-1307 USA  
Copyright (C) 2015 Real Time Engineers Ltd. All rights reserved

LICENSE CONDITIONS AND COPYRIGHT NOTICES

Commercial Software: TPS-1 FW-Stack - 1.3

Enclosed you'll find license conditions and copyright notices applicable for Commercial Software TPS-1 FW-Stack - 1.3

License conditions:

Warranty Disclaimer \*/

/\* \*/  
/\* Because the Product(s) is licensed free of charge, there is no warranty \*/  
/\* of any kind whatsoever and expressly disclaimed and excluded by NEC, \*/  
/\* \*/  
/\* either expressed or implied, including but not limited to those for \*/  
/\* non-infringement of intellectual property, merchantability and/or \*/  
/\* fitness for the particular purpose. \*/  
/\* \*/  
/\* NEC shall not have any obligation to maintain, service or provide bug \*/  
/\* fixes for the supplied Product(s) and/or the Application. \*/  
/\* \*/  
/\* Each User is solely responsible for determining the appropriateness of \*/  
/\* using the Product(s) and assumes all risks associated with its exercise \*/  
/\* of rights under this Agreement, including, but not limited to the risks \*/  
/\* and costs of program errors, compliance with applicable laws, damage to \*/  
/\* or loss of data, programs or equipment, and unavailability or \*/  
/\* interruption of operations. \*/  
/\* \*/  
/\* Limitation of Liability \*/  
/\* \*/  
/\* In no event shall NEC be liable to the User for any incidental, \*/  
/\* consequential, indirect, or punitive damage (including but not limited \*/  
/\* to lost profits) regardless of whether such liability is based on breach \*/  
/\* of contract, tort, strict liability, breach of warranties, failure of \*/  
/\* essential purpose or otherwise and even if advised of the possibility of \*/  
/\* such damages. NEC shall not be liable for any services or products \*/  
/\* provided by third party vendors, developers or consultants identified or \*/  
/\* referred to the User by NEC in connection with the Product(s) and/or the \*/  
/\* \*/  
/\* Application.

Copyrights:

(C) 1996-2006 SEGGER Microcontroller Systeme GmbH Internet: www.segger.com  
(c) 1995 - 2007 SEGGER Microcontroller Systeme www.segger.com  
(c) 1995 - 2008 SEGGER Microcontroller GmbH & Co www.segger.com  
(c) 1995 - 2012 SEGGER Microcontroller GmbH & Co KG www.segger.com  
Copyright (C) ARM Limited, 2001. All rights reserved.

Copyright (C) NEC Corporation 2004 NEC CONFIDENTIAL AND PROPRIETARY All rights reserved by NEC Corporation.

Copyright (C) NEC Corporation 2004

Copyright (c) 2002 - ARM Ltd

Copyright (c) 2003 Altera Corporation, San Jose, California, USA. All rights reserved.

Copyright (c) 2003 Altera Corporation, San Jose, California, USA. All rights reserved.

Copyright (c) 2003, 2007 Altera Corporation, San Jose, California, USA. All rights reserved.

Copyright (c) 2003-2007 Altera Corporation, San Jose, California, USA. All rights reserved.

Copyright (c) 2003-2004 Altera Corporation, San Jose, California, USA. All rights reserved.

Copyright (c) 2003-2004 Altera Corporation, San Jose, California, USA. All rights reserved.

Copyright (c) 2003-2005 Altera Corporation, San Jose, California, USA. All rights reserved.

Copyright (c) 2003-2008 Altera Corporation, San Jose, California, USA. All rights reserved.

Copyright (c) 2003-2010 Altera Corporation, San Jose, California, USA. All rights reserved.

Copyright (c) 2004 Altera Corporation, San Jose, California, USA. All rights reserved.

Copyright (c) 2004-2005 Altera Corporation, San Jose, California, USA. All rights reserved.

Copyright (c) 2005 Altera Corporation, San Jose, California, USA. All rights reserved.

Copyright (c) 2006 Altera Corporation, San Jose, California, USA. All rights reserved.

Copyright (c) 2007 Altera Corporation, San Jose, California, USA. All rights reserved.

Copyright (c) 2007 Altera Corporation, San Jose, California, USA. All rights reserved.

Copyright (c) 2008 Altera Corporation, San Jose, California, USA. All rights reserved.

Copyright (c) 2008 Altera Corporation, San Jose, California, USA. All rights reserved.

Copyright (c) 2008 Altera Corporation, San Jose, California, USA. All rights reserved.

Copyright (c) 2008 by NEC Electronics (Europe) GmbH, a company of the NEC Electronics Corporation

Copyright (c) 2008 by NEC Electronics (Europe) GmbH, a company of the NEC Electronics Corporation

Copyright (c) 2009 Altera Corporation, San Jose, California, USA. All rights reserved.

Copyright (c) 2009 Altera Corporation, San Jose, California, USA. All rights reserved.

Copyright (c) 2009 Altera Corporation, San Jose, California, USA. All rights reserved.

Copyright 2001-2008 SEGGER Microcontroller GmbH & Co. KG. All rights reserved.

Copyright 2015 by Phoenix Contact Software GmbH

Copyright ARM Ltd 2001. All rights reserved.



# Glossary

## Automation system

Programmable logic controller for the open-loop and closed-loop control of process sequences of the process engineering industry and manufacturing technology. The automation system consists of different components and integrated system functions depending on the automation task.

## Autonegotiation

Configuration protocol in the Fast Ethernet. Before the actual data transmission, the devices on the network agree a transfer mode that each participating device can master (100 Mbps or 10 Mbps, full-duplex or half-duplex).

## Baud rate

The speed at which data is transferred, which indicates the number of bits per second (baud rate = bit rate).

## Bus

Data transfer bus to which all nodes are connected. It has two defined ends.

## Bus connector

Physical connection between the bus node and the bus cable.

## Chassis ground

Chassis ground includes all the interconnected inactive parts of equipment that must not carry a hazardous voltage even in the event of a fault.

## Configuration

Systematic arrangement of the individual modules.

## Configuration control

Function that enables a flexible adjustment of the actual configuration based on a configured maximum configuration via the user program. Input, output and diagnostics addresses remain unchanged.

## CPU

The CPU supplies the electronics of the used modules via the backplane bus by means of the integrated system power supply. The CPU contains the operating system and executes the user program. The user program can be found on the SIMATIC Memory Card and is edited in the work memory of the CPU. The PROFINET interfaces available at the CPU establishes a connection to the Industrial Ethernet. The CPUs of the ET 200SP support the operation as an IO controller, I device and as a standalone CPU.

## Device name

Because a fixed IP address is assigned to the device name, an IO Device must have a device name in order to be addressed by an IO Controller. With PROFINET, this procedure is used because names are easier to handle than complex IP addresses.

The assignment of a device name for a specific IO Device can be compared with the setting of the PROFIBUS address for a DP slave.

In the state of delivery a IO Device has no device name. The IO Device can only be addressed for an IO Controller after the device has been assigned a device name with the IO Supervisor/PC, for the transfer of configuration data (IP address and other data) during startup or for the exchange of user data in cyclic operation, for example.

## Device replacement without removable media/programming device

IO Devices having this function can be replaced easily:

- A removable medium (such as SIMATIC Memory Card) on which the device name is stored is not required.
- The device name does not have to be assigned using the programming device.

Instead of being assigned a device name from the removable medium or programming device, the IO Device is now assigned a device name by the IO Controller.

The IO Controller uses the configured topology and the correlations derived from the IO Devices. The configured target topology must agree with the actual topology.

## Diagnostics

The detection, localization, classification, visualization and further evaluation of errors, disturbances and messages.

Provides monitoring functions which are executed automatically when the system is in RUN. Increases plant availability by reducing commissioning times and down times.

## Distributed I/O systems

Systems with input and output modules that are configured on a distributed basis at greater distance from the controlling CPU are, for example:

- ET 200AL, ET 200eco PN, ET 200M, ET 200MP, ET 200pro, ET 200S, ET 200 SP
- DP/AS-I Link, etc.

**Electrically isolated**

The reference potentials of the control and load circuit of isolated I/O modules are electrically isolated, for example, by means of optocoupler, relay or transformer. I/O circuits can be connected to the same potential.

**Equipotential bonding**

Electrical connection (equipotential bonding conductor) that keeps electrical equipment and extraneous conductive objects to the same or almost the same potential in order to prevent disturbing or dangerous voltages between those objects.

**External lightning protection**

External plant components at which galvanic coupling of lightning surges can occur. Corresponds with lightning protection zone 0<sub>A</sub> and 0<sub>B</sub>.

**Fast Ethernet**

Fast Ethernet describes the standard for transferring data with 100 Mbps. This transfer technology used the 100 Base-T standard for this.

**Firmware update**

Updating the firmware of modules, for example, after functional enhancements to the latest firmware version (update).

**Functional ground**

Functional ground is a low-impedance current path between electric circuits and ground. It is not designed as a protective measure but instead, for example, as a measure to improve interference immunity.

**Grounding**

Refers to the bonding of conductive elements to ground via a grounding system.

**GSD file**

As a Generic Station Description, this file contains all properties of a PROFINET or PROFIBUS device that are necessary for its configuration in XML format.

**Identification data**

Information which is stored in modules and supports the user in checking the plant configuration and finding the hardware changes.

## Industrial Ethernet

Industrial Ethernet is a configuration technology that enables data to be transferred interference-free in an industrial environment.

Standard Ethernet components can be used since PROFINET is an open system. However, we recommend setting up PROFINET as Industrial Ethernet.

## Interface module

Module in the distributed IO system. The interface module connects the distributed I/O system via a fieldbus with the CPU (IO controller) and prepares the data for or from the I/O modules.

## Internal lightning protection

Shielding of buildings, rooms or devices Corresponds with lightning protection zone 1, 2 or 3.

## IO-Link

IO-Link is a point-to-point connection to conventional and intelligent sensors/actuators via unshielded standard cable in proven 3-conductor technology. IO-Link is backwards compatible with all DI/DQ sensors/actuators. Circuit state channel and data channel designed in 24 VDC technology.

## Isochronous real-time communication

Synchronized transmission method for the cyclic exchange of IRT data between PROFINET devices

A reserved bandwidth is available within the send cycle for IRT IO data. The reserved bandwidth guarantees that IRT data can also be transmitted at reserved, synchronized intervals while other, higher network loads are active (for example, TCP/IP communication or additional real-time communication).

## MAC address

Every PROFINET device is assigned a worldwide unique device identification before it leaves the factory. This six-byte device identification is the MAC address.

The MAC address is divided into:

- Three-byte manufacturer identification and
- three-byte device identification (consecutive number)

The MAC address is generally shown on the front of the device, for example:  
08-00-06-6B-80-C0

## Non-isolated

The reference potentials of the control and load circuit of non-isolated I/O modules are electrically interconnected.

## Parameter assignment

Parameter assignment is the transfer of parameters from the IO controller/DP master to the IO device/DP slave.

## PELV

Protective Extra Low Voltage = grounded protective extra-low voltage

## Prioritized startup

Prioritized startup (FSU) denotes PROFINET functionality for accelerating the startup of IO Devices for RT and IRT communication within a PROFINET IO system.

The function reduces the time that the correspondingly configured IO devices require to return to the cyclic user data exchange in the following cases:

- After power has returned
- After station recovery
- After activation of IO Devices

## Process image (I/O)

The CPU transfers the values from the input and output modules to this memory area. At the beginning of the cyclic program, the signal states of the input modules are transferred to the process input image. At the end of the cyclic program the process image of the outputs is transferred as a signal state to the output modules.

## PROFIBUS

PROcess Field BUS, process- and fieldbus standard, which is defined in the standard IEC 61158 Type 3. It specifies functional, electrical and mechanical properties for a bit-serial fieldbus system.

PROFIBUS is available with the protocols DP (= Distributed Peripherals), FMS (= Fieldbus Message Specification), PA (= Process Automation), or TF (= Technological Functions).

## PROFIBUS International

Technical committee dedicated to the definition and development of the PROFIBUS and PROFINET standard.

Also known as the PROFIBUS Trade Organization (PTO).

Homepage: [www.profibus.com](http://www.profibus.com)

## PROFINET

Within the framework of Totally Integrated Automation (TIA), PROFINET represents a consequent enhancement of:

- PROFIBUS DP, the established field bus, and
- Industrial Ethernet, the communication bus for the cell level.

Experience gained from both systems was and is being integrated into PROFINET.

PROFINET is an Ethernet-based automation standard of PROFIBUS International (previously PROFIBUS Trade Organization) and defines a multi-vendor communication, automation and engineering model. Since 2003, PROFINET has been part of IEC 61158.

See PROFIBUS International

## PROFINET component

A PROFINET component encompasses the entire data of the hardware configuration, the parameters of the modules, and the corresponding user program. The PROFINET component is composed of:

- Technological function

The (optional) technological (software) function includes the interface to other PROFINET components in the form of interconnectable inputs and outputs.

- Device

The device is the representation of the physical automation device or field device including the IO devices, sensors, actuators, mechanics, and device firmware.

## PROFINET Device

All PROFINET devices are equipped with at least one Industrial Ethernet port. A PROFINET device can also have a PROFIBUS connection (master with proxy functionality).

## PROFINET device model

A PROFINET device can have a modular and compact structure. A modular PROFINET device consists of slots into which the modules are inserted. The modules have channels which are used to read and output process signals. A compact device has the same design. However, it cannot be physically expanded, this means that no modules/submodules can be inserted. A module can be made up of multiple submodules.

## **PROFINET IO**

Within the framework of PROFINET, PROFINET IO represents a communication concept for the implementation of modular, distributed applications.

PROFINET IO allows you to create automation solutions, which are familiar to you from PROFIBUS.

Implementation of PROFINET IO is effected on the one hand by means of the PROFINET standard for automation devices and on the other by means of the STEP 7 engineering tool. This means you have the same application view in STEP 7 regardless of whether you are configuring PROFINET devices or PROFIBUS devices. Programming your user program is essentially the same for PROFINET IO and PROFIBUS DP if you use the extended blocks and system status lists for PROFINET IO.

## **PROFINET IO Controller**

Device used to address connected IO Devices. That means: the IO Controller exchanges input and output signals with assigned field devices. The IO Controller is usually the controller running the automation program.

## **PROFINET IO Device**

Distributed field device which is assigned to one of the IO Controllers (remote IO, valve blocks, frequency converters, switches).

## **Reference potential**

Reference potential for the evaluation / measuring of the voltages of participating circuits.

## **RoHS**

EU Directive 2011/65/EU on the restriction of the use of certain hazardous substances in electrical and electronic devices regulates the use of hazardous substances in devices and components. It, together with the respective implementation in national legislation, is designated as a whole with the abbreviation RoHS (English: Restriction of the use of certain hazardous substances; German: "Use of certain hazardous substances in electrical and electronic devices").

## **SELV**

Safety Extra Low Voltage = potential-free safety extra-low voltage

## SNMP

SNMP (Simple Network Management Protocol) is the standardized protocol for diagnostics and parameter assignment of the Ethernet network infrastructure.

In the office area and in automation technology, devices support a wide range of manufacturers on the Ethernet SNMP.

SNMP-based applications can be operated parallel to applications with PROFINET on the same network.

The scope of the supported functions varies depending on the device type. A switch, for example, has more functions than a CP 1616.

## Switch

PROFIBUS is based on a line topology. Communication nodes are interconnected by means of a passive line, namely the bus.

By contrast, the Industrial Ethernet consists of point-to-point connections: Each communication node is interconnected directly with one other communication node.

If a communication node is to be interconnected with several other communication nodes, this communication node is connected to the port of an active network component, i.e., the switch. Other communication nodes (including switches) can then be connected to the other ports of the switch. The connection between a communication node and the switch remains a point-to-point connection.

The task of a switch is thus to regenerate and distribute received signals. The switch "learns" the Ethernet address(es) of a connected PROFINET device or of other switches and passes only the signals intended for the connected PROFINET device or switch.

A switch has a certain number of ports. Connect a maximum of one PROFINET device or one additional switch to each port.

## TIA Portal

Totally Integrated Automation Portal

The TIA Portal is the key to the full performance capability of Totally Integrated Automation. The software optimizes all plant, machine and process sequences.

## Total current

Total current of all output channels of a digital output module.



# Index

"

Standards and Approvals"  
Standards and Approvals"  
Standards and Approvals"  
Standards and Approvals"

## 1

16 DI DC 24V 8×M12  
Block diagram, 127  
Parameters, 130  
Pin assignment, 126  
Properties, 125  
Technical data, 128  
16 DO DC 24V/1,3A 8×M12  
Parameters, 155  
16 DO DC 24V/1.3A 8×M12  
Block diagram, 151  
Pin assignment, 150  
Properties, 149  
Technical data, 152

## 2

24 V DC supply, 29

## 4

4 AO U/I 4×M12  
Block diagram, 207  
Pin assignment, 207  
Properties, 206  
Technical specifications, 208  
4 AO U/I 4×M12  
Parameters, 212  
4 IO-L + 8 DI + 4 DO DC 24V/1,3A 8×M12  
Parameter, 226  
4 IO-L 4×M12  
Configuration, 233  
Diagnostic interrupt, 240  
Functions, 237  
Hardware interrupt, 240  
Interrupts, 239  
Master backup, 237

Parameter, 234  
Port Qualifier Information, 238  
PQI, 238  
Pull/plug interrupt, 240  
System diagnostics, 239

## 8

8 AI 4 U/I + 4 RTD/TC 8×M12  
Block diagram, 166  
Pin assignment, 164  
Properties, 163  
Technical specifications, 167  
8 AI 4 U/I + 4 RTD/TC 8×M12  
Parameter, 180  
8 AI RTD/TC 8×M12  
Block diagram, 175  
Parameter, 183  
Pin assignment, 173  
Properties, 172  
Technical specifications, 176  
8 DI DC 24V 4×M12  
Block diagram, 117  
Parameters, 130  
Pin assignment, 116  
Properties, 115  
Technical data, 118  
8 DI DC 24V 8×M12  
Block diagram, 122  
Parameters, 130  
Pin assignment, 121  
Properties, 120  
Technical data, 123  
8 DIO DC 24V/1,3A 8×M12  
Parameters, 162  
8 DIO DC 24V/1.3A 8×M12  
Block diagram, 158  
Pin assignment, 157  
Properties, 156  
Technical data, 159  
8 DO DC 24V/0,5A 4×M12  
Parameters, 155  
8 DO DC 24V/0.5A 4×M12  
Block diagram, 136  
Pin assignment, 136  
Properties, 135  
Technical data, 137  
8 DO DC 24V/1,3A 4×M12

- Parameters, 154
- 8 DO DC 24V/1,3A 8×M12
  - Parameters, 154
- 8 DO DC 24V/1.3A 4×M12
  - Block diagram, 132
  - Pin assignment, 131
  - Properties, 131
  - Technical specifications, 133
- 8 DO DC 24V/1.3A 8×M12
  - Block diagram, 141
  - Pin assignment, 140
  - Properties, 139
  - Technical data, 142
- 8 DO DC 24V/2,0A 8×M12
  - Parameters, 154
- 8 DO DC 24V/2.0A 8×M12
  - Block diagram, 146
  - Pin assignment, 145
  - Properties, 144
  - Technical data, 147

## A

- Additional support, 4
- Address space
  - 16 DI DC 24V 8×M12, 266
  - 16 DO DC 24V/1.3 A 8×M12, 268
  - 4 AO U/I 4×M12, 270
  - 4 IO-L + 8 DI + 4 DO DC 24V/1,3A 8×M12, 270
  - 4 IO-L 4×M12, 271
  - 8 AI 4 U/I + 4 RTD/TC 8×M12, 269
  - 8 AI RTD/TC 8×M12, 269
  - 8 DI DC 24V 4×M12, 265
  - 8 DI DC 24V 8×M12, 265
  - 8 DIO DC 24V/1.3 A 8×M12, 268
  - 8 DO DC 24V/0.5 A 4×M12, 267
  - 8 DO DC 24V/1.3 A 4×M12, 266
  - 8 DO DC 24V/1.3 A 8×M12, 267
  - 8 DO DC 24V/2.0 A 8×M12, 267
- Analog value, 192
- Article numbers, 248

## B

- Basic conversion time, 273
- Basic knowledge, 3
- Burst pulses, 106

## C

- Climatic environmental conditions, 108

- Commissioning
  - ET 200eco PN, 78
- Components and protective measures, 31
- Components of ET 200eco PN, 13
- Configuring, 71
  - ET 200eco PN, 68
  - IO-Link master, 69, (HW Config), (GSD), (S7-PCT), 71
- Continuous shock, 109, 109
- Conversion time, 273, 274
- Cycle time, 273, 274

## D

- Definition
  - Electromagnetic compatibility, 106
- Degree of protection IP65, 111
- Degree of protection IP66, 111
- Degree of protection IP67, 111
- Device identification, 72
- Device replacement without programming device, 75
- Diagnostics, 93
  - After IO Controller STOP, 99
  - After recovery of the IO Device, 99
- Diagnostics messages
  - PROFINET IO, 93
- Dimensional drawing, 254
- Disposal, 4
- Distributed I/O systems – application area, 10

## E

- Electrical isolation
  - between..., 33
- Electromagnetic compatibility, 106
- Electrostatic discharge, 106
- EMC, 106
- EMERGENCY-STOP devices, 29
- Emission of radio interference, 107
- Error types I/O devices, 95
- ET 200eco PN
  - Commissioning, 78
  - Components, 13
  - LED display, 87
  - Operation with grounded power supply, 30
- ET 200eco PN distributed I/O device
  - Definition, 12
  - Field of application, 12
  - IO Controller, 19
- ET 200eco PN standard modules
  - Fail-safe shutdown, 276
- Evaluating interrupts using an IO Controller, 85

Exchange object, 83

## F

Firmware update

Online, 81

Flash test, 73

Function block

LIOLink\_Device, 83

LIOLink\_Master, 83

Functional earth (FE), 35

Fuse, 29

## G

General rules

For operation of an ET 200eco PN, 29

German Technical Inspectorate report, 278

Grounded extra-low-voltage, 31

Grounded power supply, 30

GSDML file (PROFINET IO), 68

Guide, 4

## H

HW Config, 68, 73

## I

I/O device

Wiring, 37

Identification and maintenance data, 237

IEC 204, 29

Installing, 20

Insulation test, 111

IO controller

ET 200eco PN distributed I/O device, 19

IO Controller STOP

Diagnostics events triggered, 99

IO Device, 72

IO-Link Master

Functions, 228

IO-Link Master 4 IO-L + 8 DI + 4 DO DC 24V/1.3A 8×M12

Block diagram, 221

Pin assignment, 219

Properties, 218

Technical data, 222

IO-Link Master 4 IO-L 4×M12

Block diagram, 230

Pin assignment, 230

Properties, 229

Technical specifications, 231

IP address, 72

Isochronous real-time communication, 74

## L

Labels, 27

LED display

ET 200eco PN, 87

IO-Link Master 4 IO-L + 8 DI + 4 DO DC 24V/1.3A

8×M12, 89

IO-Link Master 4 IO-L 4×M12, 90

Status, 90

Voltage distributor, 92

Loop through

of PROFINET, 67

of supply voltage, 67

## M

M12 connector

connection, 37

Maintenance interrupts, 86

Manual

Purpose, 3

Measuring range

Current, 194, 195

Voltage, 193, 193, 215

Measuring ranges with SIMATIC S7, 192

Mechanical environmental conditions, 109

Media redundancy, 76

Mounting dimensions, 24

Mounting position, 24

## O

Outdoors, 110

Overall configuration on TN-S system, 32

## P

Parameter, 154, 226

Parameter assignment, 71

Parameters, 130, 162, 180, 183, 212

16 DI DC 24V 8×M12, 130

16 DO DC 24V/1,3A 8×M12, 155

4 AO U/I 4×M12, 212

4 IO-L + 8 DI + 4 DO DC 24V/1,3A 8×M12, 226

4 IO-L 4×M12, 234

- 8 AI 4 U/I + 4 RTD/TC 8xM12, 180
- 8 AI RTD/TC 8xM12, 183
- 8 DI DC 24V 4xM12, 130
- 8 DI DC 24V 8xM12, 130
- 8 DIO DC 24V/1,3A 8xM12, 162
- 8 DO DC 24V/0,5A 4xM12, 155
- 8 DO DC 24V/1,3A 4xM12, 154
- 8 DO DC 24V/1,3A 8xM12, 154
- PD DC 24V 1x7/8" 4xM12
  - Block diagram, 245
  - Pin assignment, 244
  - Properties, 244
  - Technical specifications, 246
- PELV
  - Grounded extra-low-voltage, 31
- Pin assignment
  - 16 DI DC 24V 8xM12, 43
  - 16 DO DC 24V/1.3A 8xM12, 48
  - 4 AO U/I 4xM12, 59
  - 4 IO-L + 8 DI + 4 DO DC 24V/1,3A 8xM12, 50
  - 4 IO-L 4xM12, 51
  - 8 AI 4 U/I + 4 RTD/TC 8xM12, 53
  - 8 AI RTD/TC 8xM12, 56
  - 8 DI DC 24V 4xM12, 42
  - 8 DI DC 24V 8xM12, 43
  - 8 DIO DC 24V/1,3A 8xM12, 49
  - 8 DO DC 24V/0.5A 4xM12, 46
  - 8 DO DC 24V/1.3A 4xM12, 45
  - 8 DO DC 24V/1.3A 8xM12, 47
  - 8 DO DC 24V/2.0A 8xM12, 47
  - For loop-through of the supply voltage, 41
  - For supply voltage infeed, 41
  - Of the terminal block, 62
  - PROFINET connector, 40
  - Voltage distributor PD DC 24V 1x7/8, 65
- Port, 73
- Prioritized startup, 75
- PROFINET IO, 10
  - Network topology, 11
- PROFINET IO Device, 72
- PROFINET IO standard, 100
- Protection against external electrical influences, 30
- Protection class, 111
- Pulse-shaped disturbances, 106

## R

- Radio interference, 105
- Rated voltage, 111
- Readers of this manual, 4
- Reading diagnostics data, 93
- Recovery of the IO Device

- Diagnostics events triggered, 99
- Recycling, 4
- Regulations
  - For operation of an ET 200eco PN, 29
- Removing, 28
- Replacing the fuse
  - Terminal block, 80
- Representation of analog values, 197, 197, 198, 198
- Reset to factory settings (PROFINET), 76
- Response time, 275

## S

- Safe electrical separation, 30
- Safety shutdown device, 276
- Scope of information, 3
- Scope of this manual, 3
- SELV
  - Safe electrical isolation, 30
- Settling time, 274
- Shipping conditions, 106
- Shock, 109
- Signal names, 247
- SIMATIC Manual Collection, 253
- Sinusoidal disturbance variables, 106
- Smoothing, 188
- SNMP, 77
- Standards and approvals
  - ATEX approval, 101
  - CCCEX approval, 103
  - IECEX approval, 103
  - UKCA mark, 101
  - UKEX approval, 102
- Standards and certifications, 100
  - IEC 61131, 100
- Status display 24 V DC, 89
- STEP 7, 93
- Storage conditions, 106
- Switch, 29
- System startup after certain events, 29

## T

- Technical data
  - I/O device 16 DI DC 24V 8xM12, 128
  - I/O device 16 DO DC 24V/1,3A 8xM12, 152
  - I/O device 8 DI DC 24V 4xM12, 118
  - I/O device 8 DI DC 24V 8xM12, 123
  - I/O device 8 DIO DC 24V/1,3A 8xM12, 159
  - I/O device 8 DO DC 24V/0,5A 4xM12, 137
  - I/O device 8 DO DC 24V/1,3A 8xM12, 142

---

- I/O device 8 DO DC 24V/2,0A 8×M12, 147
- Technical specifications
  - Climatic environmental conditions, 108
  - Electromagnetic compatibility, 106
  - I/O device 8 DO DC 24V/1,3A 4×M12, 133
  - Shipping and storage conditions, 106
- Technical Support, 4
- Temperature, 107
- Temperature coefficient, 187
- Terminal block
  - Block diagram, 243
  - Pin assignment, 242
  - Properties, 242
  - Technical specifications, 243
- Test voltage, 111
- TN-S system, 32

## U

### Usage

- In mixed-use zone, 105
- In residential area, 105
- Industrial, 105

## V

- Vibration, 109

## W

### Wiring

- For operation of an ET 200eco PN, 29

## Y

- Y cable, 38