

SIMATIC NET

DP/RS 232C Link

User Description

Date 02/12/1999



User Description

Gateway

DP/RS 232C Link

Version: 1.4

Date: 02/12/1999

Disclaimer of liability

Although we have checked the contents of this publication for agreement with the actual hardware and software, responsibility for complete agreement cannot be accepted. The information in this document is reviewed at regular intervals and necessary corrections included in later releases. Your suggestions are welcome.

Copyright

Copyright (C) Siemens AG 1999. All rights reserved
Passing on of this document, duplication, utilization and revelation of its contents is prohibited unless express permission is granted. Violations will be subject to damages. All rights reserved, particularly in the event a patent is granted or a utility model is registered.

Subject to change without prior notice

Content

1 NOTES ON CE SEAL OF THE INTERFACE	7
2 INTRODUCTION	9
3 THE SYSTEM	10
3.1 Data Communication	10
3.2 Possible Data Lengths	12
3.3 Booting Phase	12
4 THE TRIGGERBYTE	13
5 ADJUSTING THE LENGTH OF THE SEND DATA	13
6 THE 3964R DRIVER	14
6.1 Procedure Specifications	14
6.2 Data Communication	14
6.2.1 Introduction of Data Communication by the Low-Priority Station	14
6.2.2 Conflicts	15
6.2.3 Introduction of Data Communication by the High-Priority Station	15
7 START-END DELIMITER PROTOCOL	16
8 CHARACTER DELAY MODE	16
9 NUMBER OF CHARACTER-PROTOCOL	16
10 HARDWARE CONNECTION, SWITCHES AND LED	17
10.1 Address Setting	18
10.2 Plug Connector	18
10.2.1 Plug Connector to External Device	18
10.2.2 PROFIBUS-DP Plug Connector	18
10.2.3 Power Supply	19
10.2.4 Shield Termination	19
10.3 Setup Guidelines	19
10.3.1 Mounting the Interface Module	19
10.3.2 Wiring	20
10.3.3 Cabling, Shielding and Measures against Interference Voltage	25

11 REPRESENTATION OF THE DATA ON PROFIBUS-DP	28
11.1 Parameterization	28
11.1.1 Layout of the Parameterization Telegram (from Octet 8)	29
11.2 Configuration Telegram	32
11.3 Diagnosis	33
11.4 Data Exchange	34
12 TECHNICAL DATA	35
12.1.1 Device Data	35
12.1.2 Interface Data	37
13 COMMISSIONING GUIDELINES	38
14 LIST OF RELATED LITERATURE	39

1 Notes on CE Seal of the Interface

EU guidelines on EMC 89/336/EEC

The following information applies to the interface described in this manual.

Products bearing the CE seal meet the requirements of EU guidelines 89/336/EEC on electromagnetic compatibility and the harmonized European standards contained therein.

The EU declarations of conformity are available at the following address for viewing by responsible authorities in accordance with article 10 of the above stated EU guidelines.

Siemens Aktiengesellschaft
 Bereich Antriebs-, Schalt- und Installationstechnik
 ASI 2
 Postfach 1954
 D-92220 Amberg

Application area

The interface modules are designed for use in industrial applications and meet the following requirements.

Application Area	Requirements on	
	Interference Emission	Interference Immunity
Industry	EN 50081-2 : 1993	EN 50082-2 : 1995

When individual approval is granted, the interface module can also be used in residential areas (e.g., residential, business and commercial zones and small businesses).

Application Area	Requirements on	
	Interference Emission	Interference Immunity
Residential areas	Individual approval	EN 50082-1 : 1992

Individual approval must be obtained from an appropriate authority or inspection office. In Germany, this document can be obtained from the Bundesamt für Post und Telekommunikation and its branches.

Adherence to setup guidelines

The interface module complies with the requirements when the following guidelines are adhered to.

1. Setup guidelines for installation and operating contained in the operating instructions
2. The following rules covering the installation of the device and work on switching cabinets

Installation

Interface modules must be installed in electrical equipment rooms or in closed housings (e.g., control boxes of metal or plastic). In addition, the device and the metal control box or at least the top hat rail (plastic box) snapped onto the interface must be grounded.

Work on switching cabinets

To protect the modules from discharge of static electricity, personnel must discharge themselves electrostatically before opening the switching cabinets or control boxes.

Notes for the Manufacturer of Machines

Introduction

Since the DP/RS232 interface is not a machine in the sense of the EU guidelines, it does not require a declaration of conformity in accordance with EU guideline 89/392/EEC on machines.

EU guidelines on machines 89/392/EEC

EU guideline 89/392/EEC on machines covers the requirements for machines. A machine is defined as an entity of connected parts or devices. See also paragraph 3.1 of EN 292-1.

Since the interface is part of the electrical equipment of a machine, the manufacturer of the machine must include it in the declaration of conformity procedure.

2 Introduction

The DP/RS232 interface is used to adapt a serial interface on PROFIBUS-DP in accordance with EN 50 170. In this application, it is used as a gateway and operates as a PROFIBUS-DP slave. It can be operated by any standard master. Two transmission procedures are supported by the serial interface.

- The 3964R procedure widely used by Siemens devices
- A free ASCII protocol with control over Character delay time, Start / End delimiter or constant data length

These two procedures cover the great majority of applications.

The interface consists of the following primary hardware components.

- Floating RS 485 interface to PROFIBUS DP
- SPC3 PROFIBUS ASIC
- 80 C 32 micro-processor
- RAM and EPROM
- Serial interface to the externally connected device

**PROFIBUS
maste**

Configuring with COM PROFIBUS

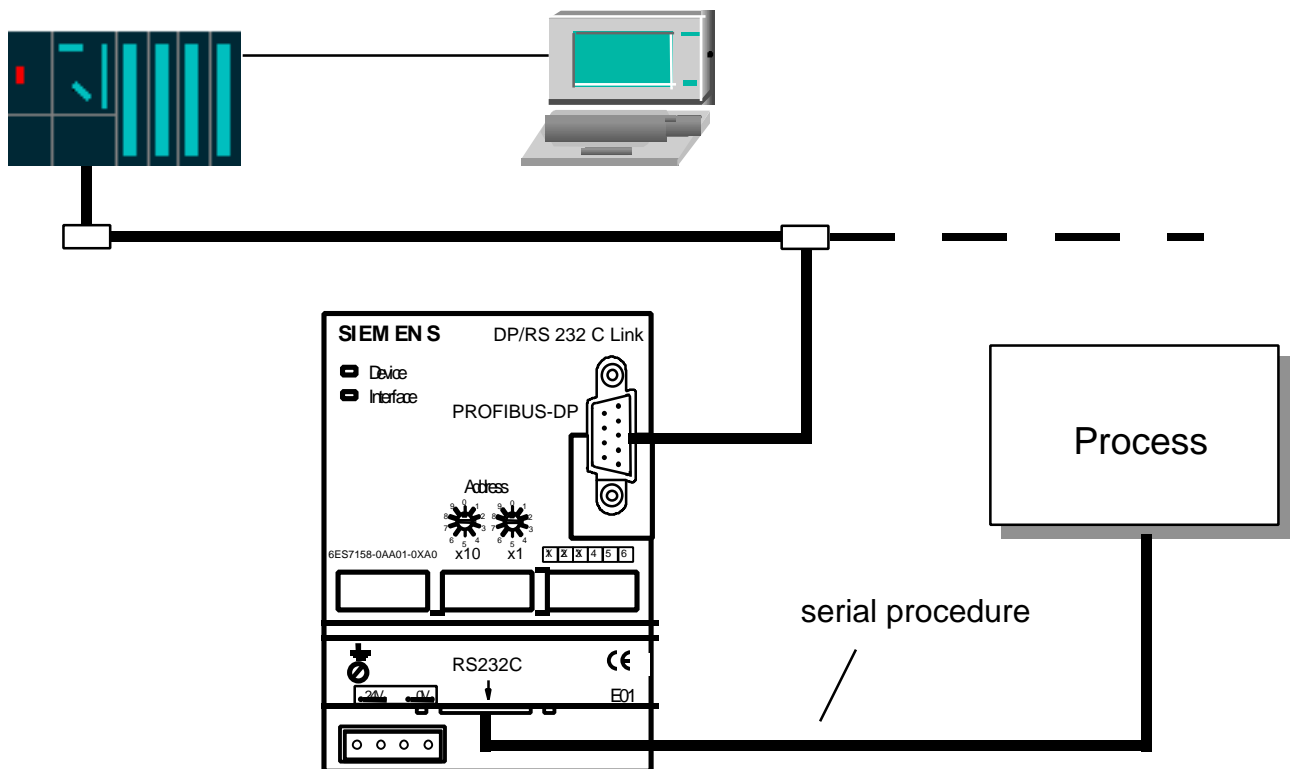

Figure 1: Overview

3 The System

3.1 Data Communication

The PROFIBUS master sends the output data cyclically to the gateway. The gateway compares the data received from the master with the previous telegram. When changes are detected, the gateway sends the data to the external device in accordance with the selected procedure. When no changes are detected, the telegram is not sent to the external device (i.e., each telegram is only sent once to the external device). The external device responds in accordance with procedure conventions. The gateway always sends the data received from the external device to the master without changes.

The gateway writes the data received from the external device in the internal RAM of the SPC3. The updated data are transferred during the next polling cycle with the gateway.

All data are transferred in both directions by the gateway with consistency. The maximum length of consistent data must be adhered to during data communication between the master and the CPU. This is usually dependent on the master interface and CPU being used.

Construction of data:

<i>Triggerbyte</i>	<i>Byte</i>
<i>Number of characters</i>	<i>Byte</i>
Userdata	Bytes

Triggerbyte and Number of characters are only present when the corresponding flag is set.

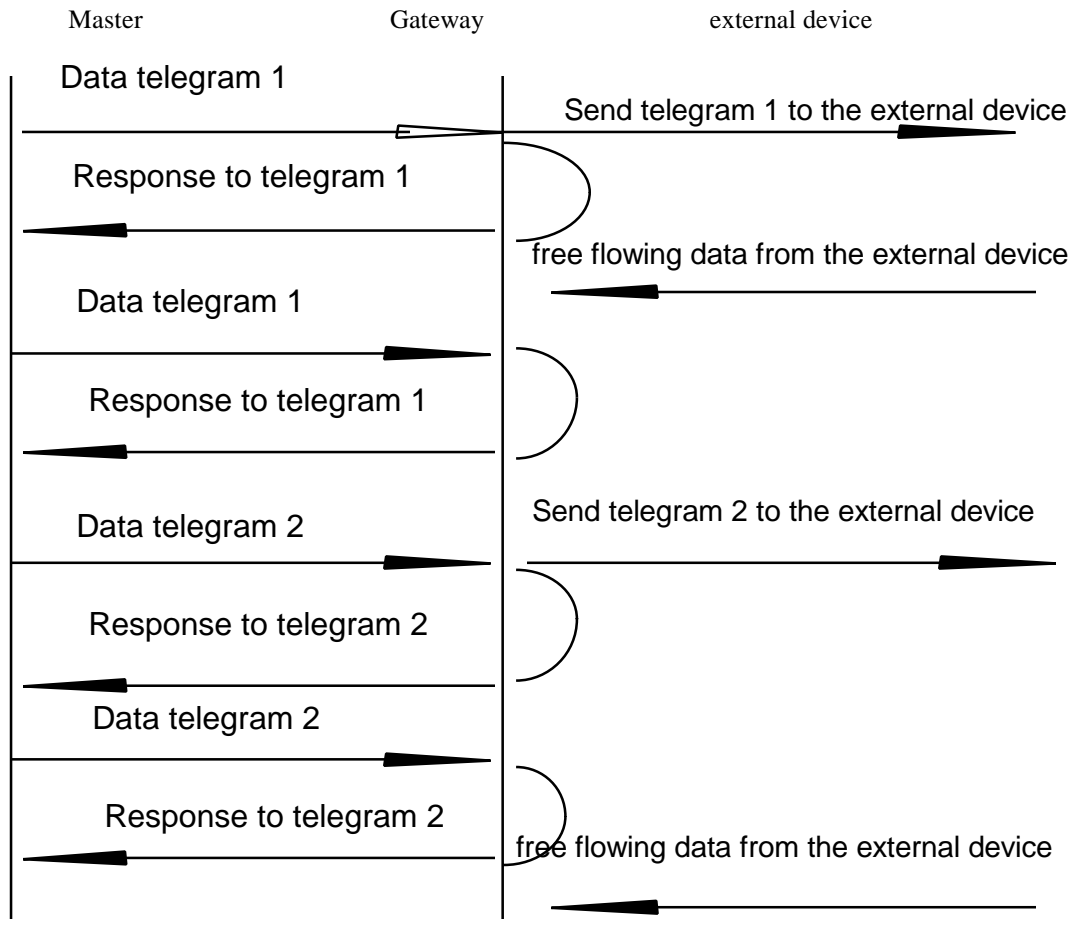

Figure 2: Data communication

3.2 Possible Data Lengths

The following table shows the maximum data which can be transferred. To transfer the data with consistency, one or more buffers have been set up on the SPC3 for each service. The number of buffers required by the SPC3 for this service is indicated in parentheses.

Input data (3)	224 bytes x 3 = 672	3 buffers for consistent data transmission	Varies: Maximum value is given here.
Output data (3)	224 bytes x = 672	3 buffers for consistent data transmission	Varies: Maximum value is given here.
Parameter (1)	9 bytes x 1 = 9	7 bytes are required by the system.	Permanently specified here
Configuration data (2)	8 bytes x 2 = 16	The I/O configuration can be written with 4 bytes.	Permanently specified
Diagnosis (2)	8 bytes x 2 = 16	7 bytes of standard diagnosis without user diagnosis	Permanently specified
Auxiliary buffer (2)	9 bytes x 2 = 18	Select to accommodate the longest telegram from configuration, parameterization and Set Slave Address	Permanently specified
Total data	1403		
Reserved	1416		

The sum of all buffers on the SPC3 may not exceed 1472 bytes modulo 8 since each buffer starts at an 8-byte boundary.

3.3 Booting Phase

During the booting phase, the master parameterizes and configures the gateway. Data communication with the external device is not started until the booting phase has been concluded successfully.

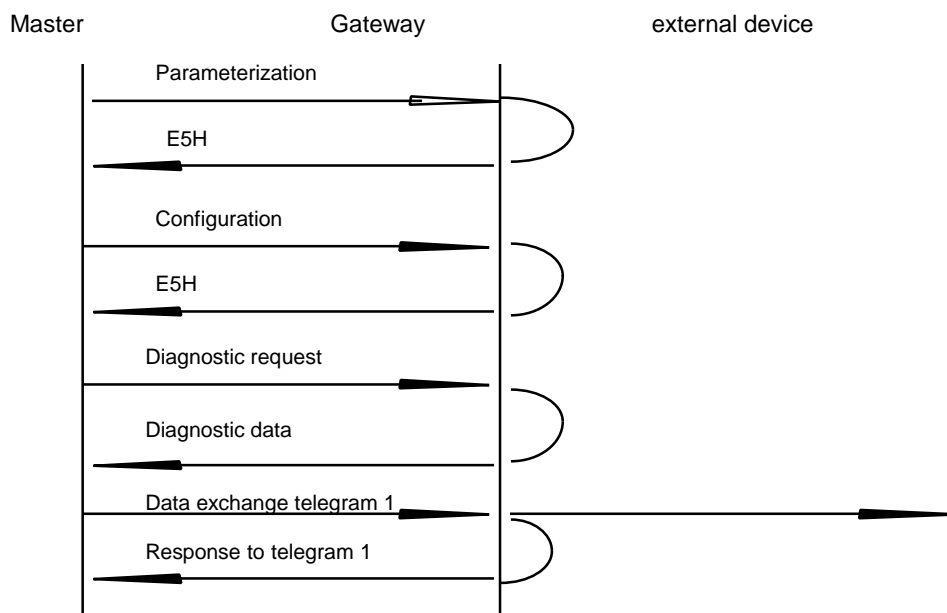

Figure 3: Booting phase

4 The Triggerbyte

As the data transmission on PROFIBUS is done cyclically the gateway has to recognize when new data should be transferred via the serial interface. Normally this is done by comparing the internal data with the new received data from PROFIBUS. In some cases this procedure doesn't work, f.e. when the same data should be send twice or more. The user can influence this behaviour by adjusting the triggerbyte..In this mode the data is only send when the triggerbyte changes.

In the normal mode the program in the gateway cannot detect whether the gateway has received several same telegrams. But when the trigger byte mode is switched on the gateway increments the triggerbyte at anytime it has received a new telegram. When the trigger byte mode is switched on it is always the first byte in the data unit.

If the Send-Ready-Trigger is used, the lower 7 bits of the Triggerbytes in the input-data is used like described above However the MSB toggles each time a send-telegram has finished.

5 Adjusting the Length of the Send Data

The meaning of one bit in the flags register is to tell the fuser programm in the gateway whether the length of the data to be send is included in the data unit. The gateway will only send as much data as it is defined. This mode only makes sense in combination with the trigger byte. In the receive direction the gateway stores the number of received characters in this byte.

6 The 3964R Driver

The 3964 driver package is used to transfer data between 2 serial devices. To resolve initialization conflicts, one partner must have high priority and the other low priority.

The interface consists of 3 parts.

- The initialization part
- The cyclical part
- The functions in the interrupt handlers

6.1 Procedure Specifications

The telegram format is described below.

- STX, data, DLE, ETX, BCC (1 start bit, 8 data bits, 1 stop bit, even parity)
- The received user data are transferred in both directions without changes (i.e., transparent).
- Data blocking is not provided.
- The user data length is restricted to 224 bytes per telegram.
- Communication is always performed between high and low-priority communication partners.

6.2 Data Communication

6.2.1 Introduction of Data Communication by the Low-Priority Station

When the low-priority station receives an STX in response to an STX, it interrupts its request to send, assumes receiving mode, and acknowledges the received STX with DLE.

High-Priority Station

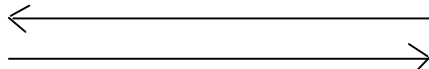
STX 

High-priority station wants to send too.

STX

Data, DLE, ETX, BCC

Low-Priority Station

STX

Station assumes receiving mode.

DLE

DLE positive acknowledgment or
NAK negative acknowledgment

A DLE in the data string is doubled and included in the checksum. BCC is calculated from the XOR linking of all characters.

6.2.2 Conflicts

6.2.2.1 Monitoring Times

tq = Acknowledgment monitoring time (2 sec)

The acknowledgment monitoring time is started after the STX control character is sent. When a positive acknowledgment is not received during the acknowledgment monitoring time, the job is repeated a maximum of 2 times. When the job could not be concluded positively despite 2 retries, the high-priority device attempts to contact the low-priority station by sending the STX control character. The cycle corresponds to tq.

tz = Character monitoring time (200 msec)

When the 3964R driver receives data, it monitors the arrival of the individual characters during time tz. When no character is received during the monitoring time, the procedure concludes the transmission. An acknowledgment is not sent to the other station.

6.2.2.2 Retries

When acknowledgment is negative or the time is exceeded, a telegram sent by the high-priority station is repeated twice.

6.2.3 Introduction of Data Communication by the High-Priority Station

High-Priority Station

STX

Data DLE ETX BCC

Low-Priority Station

DLE

DLE positive acknowledgment or
NAK negative acknowledgment

When acknowledgment is negative or the time is exceeded, a telegram sent by the external device is repeated twice.

7 Start-End Delimiter Protocol

Protocol: (< Start delimiter>), Net data, < End delimiter> (< 2nd End delimiter>)

The character in brackets are optional.

The Start-End delimiter are transmitted transparently that means they have to be stored in the send buffer by the user.

Receive direction:

When the start delimiter is switched on the gateway synchronises the gateway with this character. If not the gateway stores the next received character in the receive buffer. The telegram ends when the end delimiter is recognized.

send direction:

When the flag 'length byte' is set the required length is transmitted. If not the data is transmitted until the end delimiter is detected. The maximum data that can be transmitted always corresponds to the adjusted length in the configuration telegram.

Attention:

In this mode the timeout detection is active and aborts a receive-telegram if the delay time is expired. This can be inhibited by switching off the timeout monitoring.

8 Character Delay Mode

no protocol

Receive direction:

The received data are stored in the send buffer until the character delay time has run out. This time monitoring is adjusted in the parameterization telegram.

send direction:

The data is transmitted transparently.

Attention:

In this mode the timeout monitoring must not be switched off!

9 Number of Character-Protocol

The data are transferred transparently without time monitoring. The user specifies the data for the master. When changes are detected, these data are sent to the external device without monitoring. A response from the external device is also sent to the master unchanged. Any desired security mechanisms for user data must be provided by the user.

10 Hardware Connection, Switches and LED

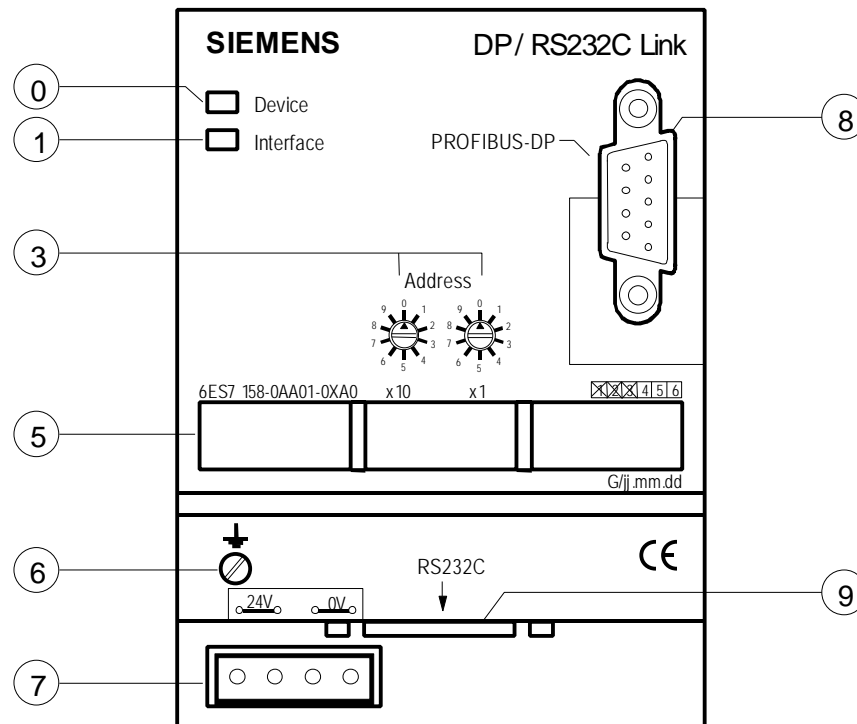

- ① Device-LED:
- green → Device is ready for operation
 - red → Device malfunction. No function possible
 - off → Device is not turned on
- ① Interface-LED:
- green → both Interfaces ok
 - yellow → Interface 1 unclear (PROFIBUS-DP)
 - off → Interface 2 unclear (RS232C)
 - red → both interfaces unclear
- Address-switch für PROFIBUS-DP (Address 0 ... 99)
- Labels
- Earth terminal for shield
- Power supply
- Interface 1: → PROFIBUS-DP (9-pin SUB-D female)
- Interface 2: → RS232C (9-pin SUB-D-male)

10.1 Address Setting

The PROFIBUS address must be set with the two rotary type switches accessible on the front plate. The tens digit of the address is set with rotary switch x10. The ones digit is set with rotary switch x1.

Caution

The address 99 is reserved for test purposes.

The black dot indicates the respective switch position. The slit on the switch is vertical to the dot.

10.2 Plug Connector

10.2.1 Plug Connector to External Device

The connection cable to the external device must be plugged into the plug connector accessible on the front plate.

Pin assignment (9-pin sub D male connector)

Pin No.	Name	Function
1		--
2	RxD	Asynchronous serial transmit data RS232
3	TxD	Asynchronous serial receive data RS232
4		
5	GND	Reference potential of control electronics
6		
7	RTS	Request to Send (not used)
8	CTS	Clear to Send (not used)
9		

10.2.2 PROFIBUS-DP Plug Connector

The plug connector (labeled PROFIBUS-DP) for connection to PROFIBUS is located on the underside of the device.

Pin assignment (9-pin sub D female connector)

Pin No.	Name	Function
1	Shield	
2		
3	B	Non-inverting input/output signal of PROFIBUS
4		
5	M5	DGND - data reference potential
6	P5	5 V supply voltage
7		
8	A	Inverting input/output signal of PROFIBUS
9		

10.2.3 Power Supply

The device must be supplied with 24 V via a 4-pin, plug-in, screw-type terminal. The 24 V supply can be looped through.

Pin No.	Name	Function
1	P24	24 V supply voltage
2	P24	24 V supply voltage
3	M24	0 V supply voltage
4	M24	0 V supply voltage

10.2.4 Shield Termination

The shield signal for the electronic circuit is connected to the top hat rail with the shield plate. For reasons of interference immunity, the shield signal for the cable shield is not connected to the shield signal of the electronic circuit. It must be applied to the screw terminal on the front plate.

10.3 Setup Guidelines

10.3.1 Mounting the Interface Module

Since the interface module has been developed for use in switching cabinets (IP20), it can only be secured on a standard rail (i.e., low top hat rail in accordance with EN 50022).

Mounting

- Hang the module in the top hat rail from the top.
- Swing it down until the sliding switch on the module snaps in.
- Other modules may be installed to the left and right of the interface module.
- At least 5 cm of free space must be provided for heat dissipation above and below the module.
- The standard rail must be connected with the equipotential bonding rail of the switching cabinet. The connection wire must have a cross section of at least **10 mm²**.
- A grounding terminal must be placed next to the interface so that the shield connection to the device with a flexible wire (**1.5 mm²**) can be kept as short as possible.

Demounting

- Disconnect the power and signal lines first.
- Then push down the sliding switch on the module with a screwdriver.
- Swing out the interface from the top hot rail.

Figure 1: Mounting and demounting

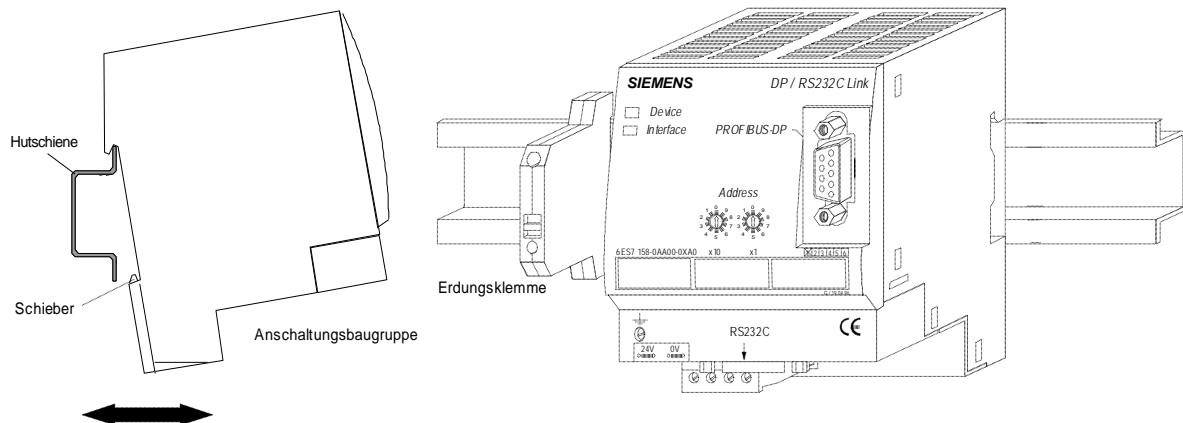

Vertical installation

The standard rail can also be mounted vertically so that the interface module is mounted at an angle of 90°. Since heat dissipation through convection is less when this type of mounting is used, the permissible ambient temperature is reduced to a maximum of 40° C.

10.3.2 Wiring

10.3.2.1 Connection Techniques

The following connection techniques must/can be used to wire the interface module.

- Standard screw-type connection (Grounding terminal)
- Plug-in terminals (Connection terminals for the power supply)
- 9-pin sub D plug-in connector (PROFIBUS-DP and 3WN6 connection)

a) One line can be connected per terminal point for the standard screw-type terminals. A screwdriver with a blade width of 3.5 mm is recommended to tighten the screws.

Permissible cross sections of the line:

- Flexible line with core end bushing: 1 x 0.25 to 1.5 mm²
- Solid line: 1 x 0.25 to 1.5 mm²

Turning moment: 0.5 to 0.8 Nm

b) The plug-in terminal strips are a combination of the standard screw-type connection and the plug-in connector. The plug-in connection portion is coded so that it cannot be inserted incorrectly.

c) The 9-pin sub D plug-in connectors are secured with two "4-40-UNC" thread screws. A screwdriver with a blade width of 3.5 mm is recommended to tighten the screws.

Turning moment: 0.2 to 0.4 Nm

10.3.2.2 RS 232C Communication Interface

This interface is equipped with a 9-pin sub D pin strip on the interface.

- Connect the connector of your RS 232C line to the 9-pin sub D pin strip labeled "**RS232C**".

- Connect the other connector of the RS 232C connection line to the appropriate communication plug-in connector on your communication partner.
- Tighten the screws on the plug connectors with the screwdriver.

Figure 2: "RS 232C" communication interface

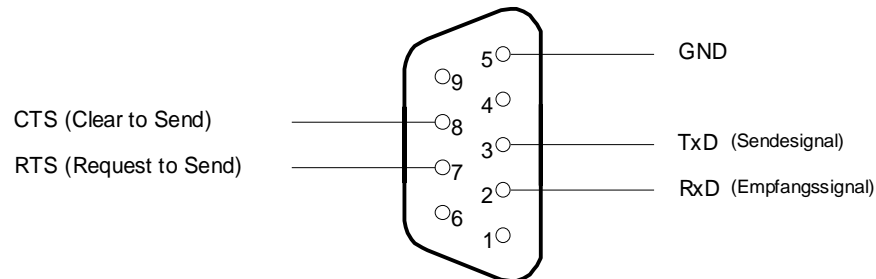

Remember	CTS and RTS
!	The CTS and RTS control signal is not supported.

10.3.2.3 PROFIBUS-DP Communication Interface

Bus line with copper cable

This interface is located on the interface module in the form of a 9-pin sub D socket on the front of the housing.

- Connect the PROFIBUS connection plug (6ES5... or 6ES7972-...) to the sub D socket labeled "**PROFIBUS-DP**". Remember that the "6ES5..." connection plugs are only suitable for baud rates up to 1.5 Mbit/sec.
- Tighten the screws of the connection plug with a screwdriver.
- If the interface module is located at the beginning or the end of the PROFIBUS line, you must also circuit the bus terminating resistor integrated in the connection plug. To do this, slide the sliding switch on the back of the connection plug to the position labeled "**on**".

If the module is not located at the beginning or the end of the PROFIBUS line, the sliding switch must be in the position labeled "**off**".

Figure 3: "PROFIBUS-DP" communication interface

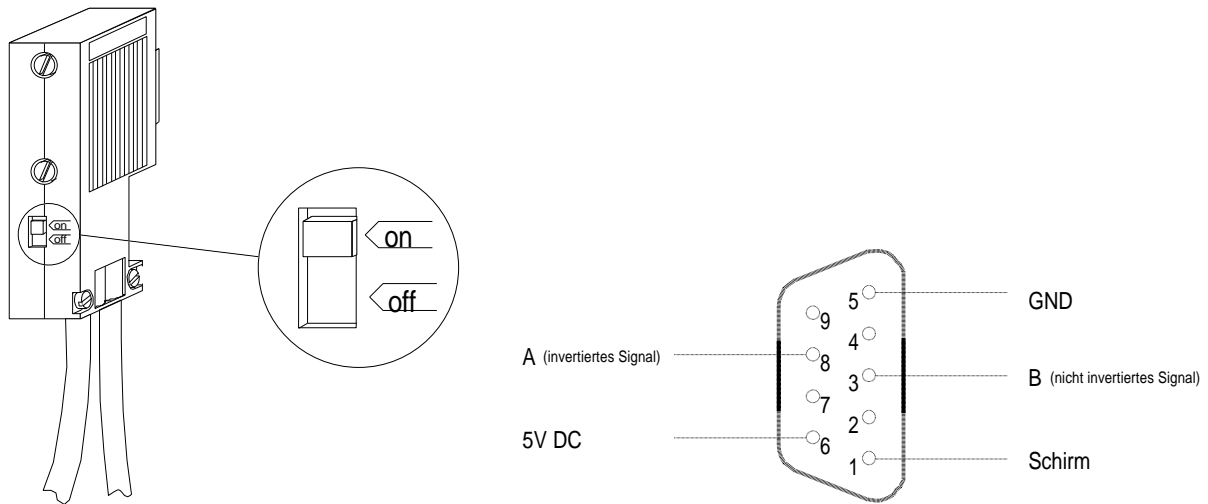

Bus with LWL

The PROFIBUS-DP interface can also be used for an LWL connection with the aid of an OLP (Optical Link Plug) (i.e., the interface provides the maximum current of 80 mA required for the OLP).

- The OLP is available under the following order number: 6GK1502-1AA00.
- Connect the OLP to the interface labeled "**PROFIBUS-DP**".
- Tighten the screw of the OLP with a screwdriver.
- Connect the two LWL connections to the sockets provided on the OLP.
- Set the desired baud rate on the OLP as explained in the description of the OLP.
- A bus terminating resistor is not required for the LWL.

Remember	<i>Limited baud rate with the OLP</i>
!	If you use an OLP, you cannot utilize all the baud rates offered by the interface (9.6 kbit/sec to 12 Mbit/sec). Only the baud rates 93.75/187.5/500 or 1500 kbit/sec can be used.

10.3.2.4 Power Supply

The device must be powered with 24 V DC via a 4-pin, plug-in, screw-type terminal. The 24 V DC voltage of the power pack may fluctuate between 20.4 V and 28.8 V in accordance with the DIN 19240 standard. Using the 4-pin plug-in, screw-type terminal, the 24 V power can be looped to an additional device. However, remember that the supply voltage is looped via the device (i.e., the looped-through supply voltage is interrupted when the screw-type terminal is disconnected).

- Connect the supply voltage to the 4-pin, screw-type terminal in accordance with the labeling on the front plate of the device.

Figure 4: Connection of the power supply

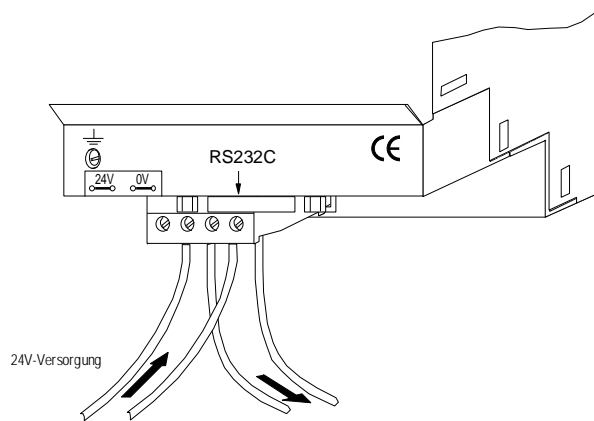

10.3.2.5 Shield Connection

The interface module is equipped with two contact points for the shield connection. These two shields are galvanically isolated inside the device, and are connected to the equipotential bonding rail outside the module. This increases the interference immunity of the module since the "cable shield current" which can amount to several amperes due to potential differences between two bus stations does not flow over the device.

The **first** shield connection (i.e., shield for internal filter connections) is located on the floor plate of the interface and is connected **automatically** when the module is placed on the top hat rail.

Remember	<i>High strain</i>
!	<p>If the device is subjected to high physical or chemical stress, use of a tin-plated top hat rail is recommended since it provides better shield connection contact.</p> <p>Order no: 6ES5 710-8MA11 ---> Length of 483 mm for 19-inch cabinets 6ES5 710-8MA21 ---> Length of 530 mm for 600-mm cabinets 6ES5 710-8MA31 ---> Length of 830 mm for 830-mm cabinets 6ES5 710-8MA41 ---> Length of 2 m</p>

Figure 5: Shield contact to the top hat rail

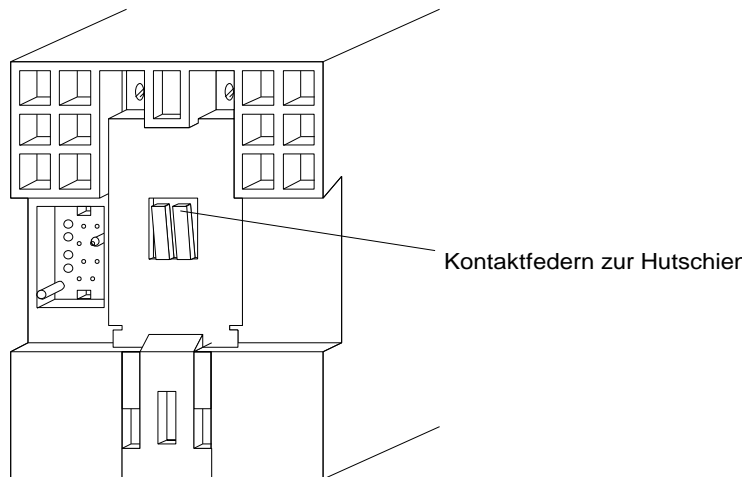

The **second** shield connection (i.e., cable shields) is located on the front of the module in the form of screw-type terminal. This screw-type terminal is used to ground the cable shields of the bus lines.

- Place a grounding terminal (example of an order no: *8WA1001-1PF00*) on the top hat rail directly next to the module. The grounding terminal automatically establishes a galvanic connection to the top hat rail.
- Connect the shield connection terminal to the grounding terminal using a flexible wire with a diameter of **1.5 mm²** and as short a length as possible.
- Connect the top hat rail to the equipotential bonding rail as low ohmic as possible. Use a flexible grounding wire with a cross section of at least **10 mm²** .
(--> **Chapter 0**)

Figure 6: Completely installed interface

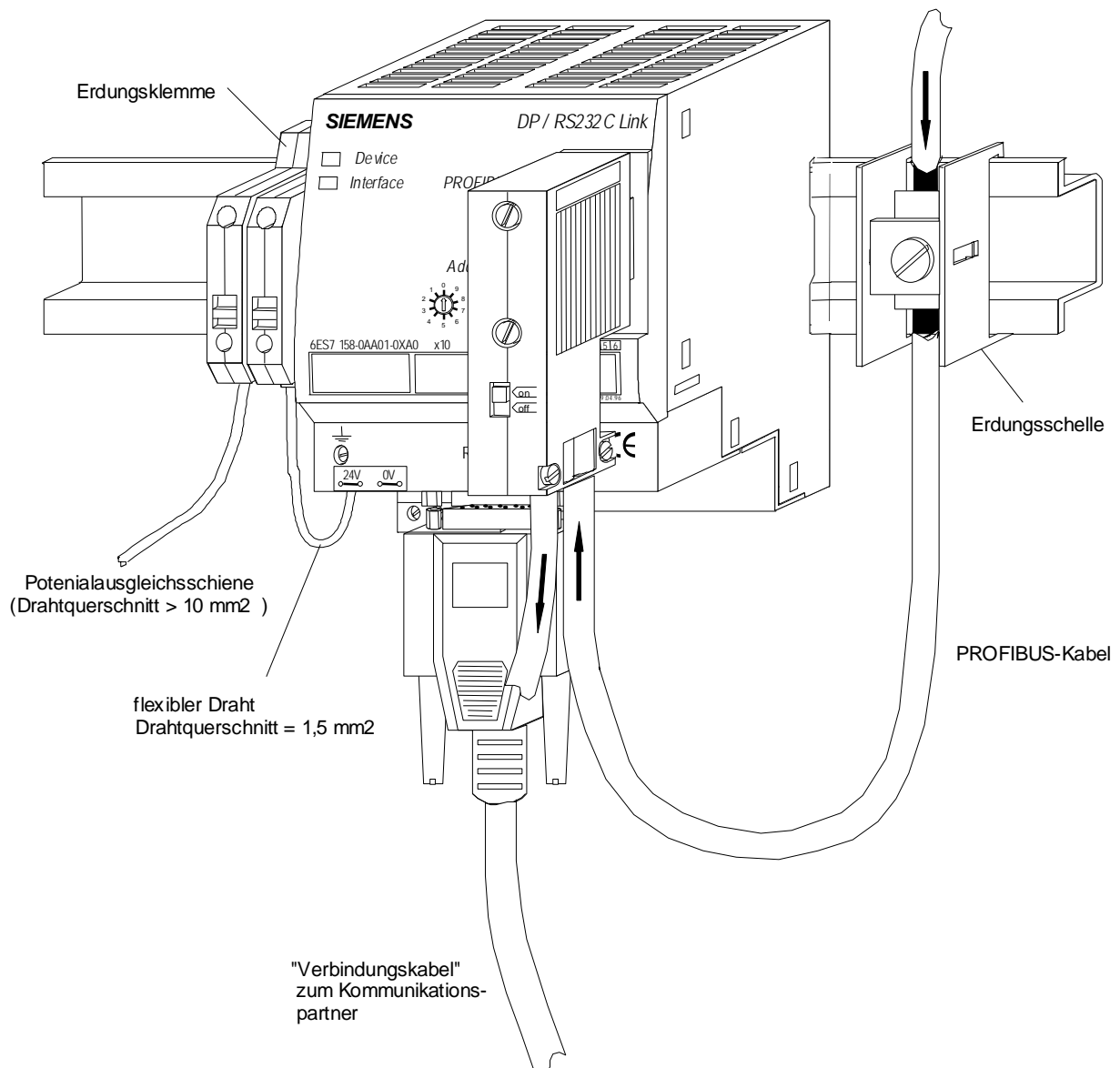

10.3.3 Cabling, Shielding and Measures against Interference Voltage

This chapter describes how to arrange the bus, signal and power cables so that your system will conform to EMC requirements.

10.3.3.1 General Information on Cabling

a) Inside and Outside Cabinets

To meet EMC requirements, we recommend dividing the cables into the following groups and installing these groups separately from each other.

- ⇒ Group A: • Shielded bus and data lines (e.g., for PROFIBUS-DP, 3WN6, printer and so on)
 - Shielded analog lines
 - Unshielded lines for direct current ≤ 60 V
 - Unshielded lines for alternating current ≤ 25 V
 - Coaxial lines for monitors
- ⇒ Group B: • Unshielded lines for direct current ≥ 60 V and ≤ 400 V
 - Unshielded lines for alternating current ≥ 24 V and ≤ 400 V
- ⇒ Group C: • Unshielded lines for direct current > 400 V
- ⇒ Group D: • Lines for SINEC H1 (Ethernet)

Using the following table, you can determine the requirements for installing the cable groups by combining the individual groups.

Table 1: Cable installation regulations based on the combination of cable groups

	Group A	Group B	Group C	Group D
Group A	①			
Group B		①		
Group C			①	
Group D				①

- ① Cables can be installed in common bundles or cable ducts.
 Cables must be installed in separate bundles or cable ducts (within a minimum distance).
 Inside cabinets, cables must be installed in separate bundles or cable ducts. Outside cabinets but inside buildings, cables must be installed in separate cable racks at a minimum distance of 10 cm.
 Cables must be installed in separate bundles or cable ducts at a minimum distance of 50 cm.

b) Outside Buildings

If possible, install cables located outside buildings on metal cable supports. Provide galvanically isolated connection of the joining points of the cable supports, and ground the cable supports. When cables are installed outside buildings, you must also provide required lightning protection and grounding measures.

Applicable in general:

- **Lightning protection:** ⇒ If cables and lines for the interface are to be installed outside buildings, measures for internal and external lightning protection must be provided.
 - ⇒ Outside buildings, install the cables in one of the following.
 - Metal pipes grounded on both sides
 - Concrete cable ducts with armouring connected throughout
 - ⇒ Use one of the following methods to protect signal lines from overvoltages.
 - Varistors
 - Overvoltage diverter filled with inert gas ("ÜsAg")

⇒ Install these protective elements where the cable enters the building.

- **Equipotential bonding:** ⇒ Provide sufficient equipotential bonding between the connected devices.

10.3.3.2 Equipotential Bonding

Differences in potential between separate system parts can occur under one of the following conditions.

- Programmable controllers and I/O devices are connected via non-floating couplings.
- Cable shields are applied on both sides and grounded on different system parts.

Differences in potential can be caused by differing power supplies, for example. These differences must be reduced by using equipotential bonding lines so that the electronic components will function correctly.

The following points apply to equipotential bonding.

- The effectiveness of equipotential bonding increases the lower the impedance of the equipotential bonding line is.
- If shielded signal lines which are connected on both sides with ground/protective conductor are installed between the affected system parts, the impedance of the additional equipotential bonding line may not exceed 10% of the shield impedance.
- The cross section of the equipotential bonding line must be dimensioned for the maximum equalizing current. The following cross sections have proved effective in actual practice.
 - 16 mm² Cu for equipotential bonding lines up to 200 m in length
 - 25 mm² Cu for equipotential bonding lines over 200 m in length
- Use equipotential bonding conductors of copper (Cu) or galvanized steel. Equipotential bonding conductors must be connected over a large surface to ground/protective conductor and protected against corrosion.
- The equipotential bonding conductor should be installed so that very small surfaces between equipotential bonding conductor and signal lines are included.

10.3.3.3 Cable Shielding

Shielding is intended to reduce (i.e., attenuate) magnetic, electrical or electromagnetic fields of interference.

Interference currents on cable shields are diverted to ground via the shield rail which is conductively connected to the housing. A low-impedance connection to the protective conductor is particularly important so that these interference currents do not become a source of interference themselves.

If possible, use only cables with shield braiding. The covering density of the shield should be more than 80%. Avoid using foil shields since pulling and pressure at the mounting points can damage the foil very easily and thus reduce the effectiveness of the shield.

Cable shields should usually be applied on both sides. Two-sided shield connection is the only way to achieve good interference suppression in high-frequency areas.

Only under exceptional conditions may the shield be applied on only one side. However, this only attenuates the lower frequencies. A one-sided shield connection may be better under the following conditions.

- Installation of an equipotential bonding line is impossible.
- Analog signals (several mV or mA) are being transmitted.
- Foil shields (i.e., static shields) are being used.

Always use metallic or metallized plug connectors for data lines for serial couplings. Secure the shield of the data line to the plug's housing. Do **not** apply the shield to PIN1 of the plug connector strip.

Remember	<i>Potential differences</i>
!	If there are potential differences between the grounding points, an equalizing current can flow over the shield which is connected on both sides. If this is the case, install an additional equipotential bonding line.

Remember the following points when working with shields.

- Use metal cable clamps to secure the shield's braiding. The clamps must surround the shield over a large surface and provide good contact.
- Apply the shield on a shield rail directly where the line enters the cabinet. Continue the shield up to the module, but do **not** apply it again there.

Figure 7: Possible implementations of a cable shield

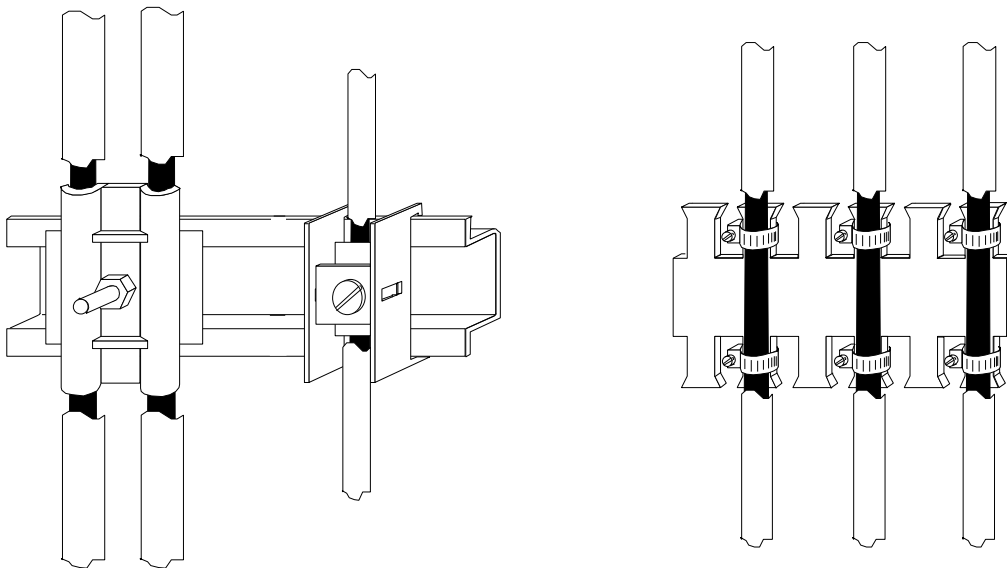

Shielded data lines and unshielded power supply lines (< 60 V DC) are led to the interface module and connected. All cable shields must be grounded on both sides so that the interface module meets all required EMC limit values.

- The PROFIBUS-DP cable shield must be applied to the equipotential bonding rail where it enters the cabinet.
- The shielded RS 232C connection cable must be grounded via the shield terminal on the interface module. Use a flexible wire with a cross section of at least **1.5 mm²** and as short a length as possible.
- The other side of the cable shield of the RS 232C connection cable must also be grounded.

See also chapter 0 10.3.2.5 Shield Connection.

11 Representation of the Data on PROFIBUS-DP

All standard PROFIBUS-DP masters can exchange data with the gateway. The data structure permits very simple master interfaces to be used.

11.1 Parameterization

The master uses the parameterization telegram to identify itself to the slave and specify the mode which the slave is to use.

The following parameterization capabilities are standard.

- The slave operates with/without the watchdog. This is required for security reasons to determine whether a master is still active.
- Specification of the TSDR (i.e., minimum time before which a slave cannot respond after adherence to the bus quiet time)
- Freeze/sync mode (e.g., for drives and counters)
- DP slave is/is not enabled for other masters.
- Specification of a group allocation for global control telegrams. Each bit stands for one group.
- Master address for clear identification
- User-related parameters (e.g., reaction when master assumes clear state)

11.1.1 Layout of the Parameterization Telegram (from Octet 8)

In most cases the user constructs the parameterization telegram by using a commissioning tool (for example COM PROFIBUS)

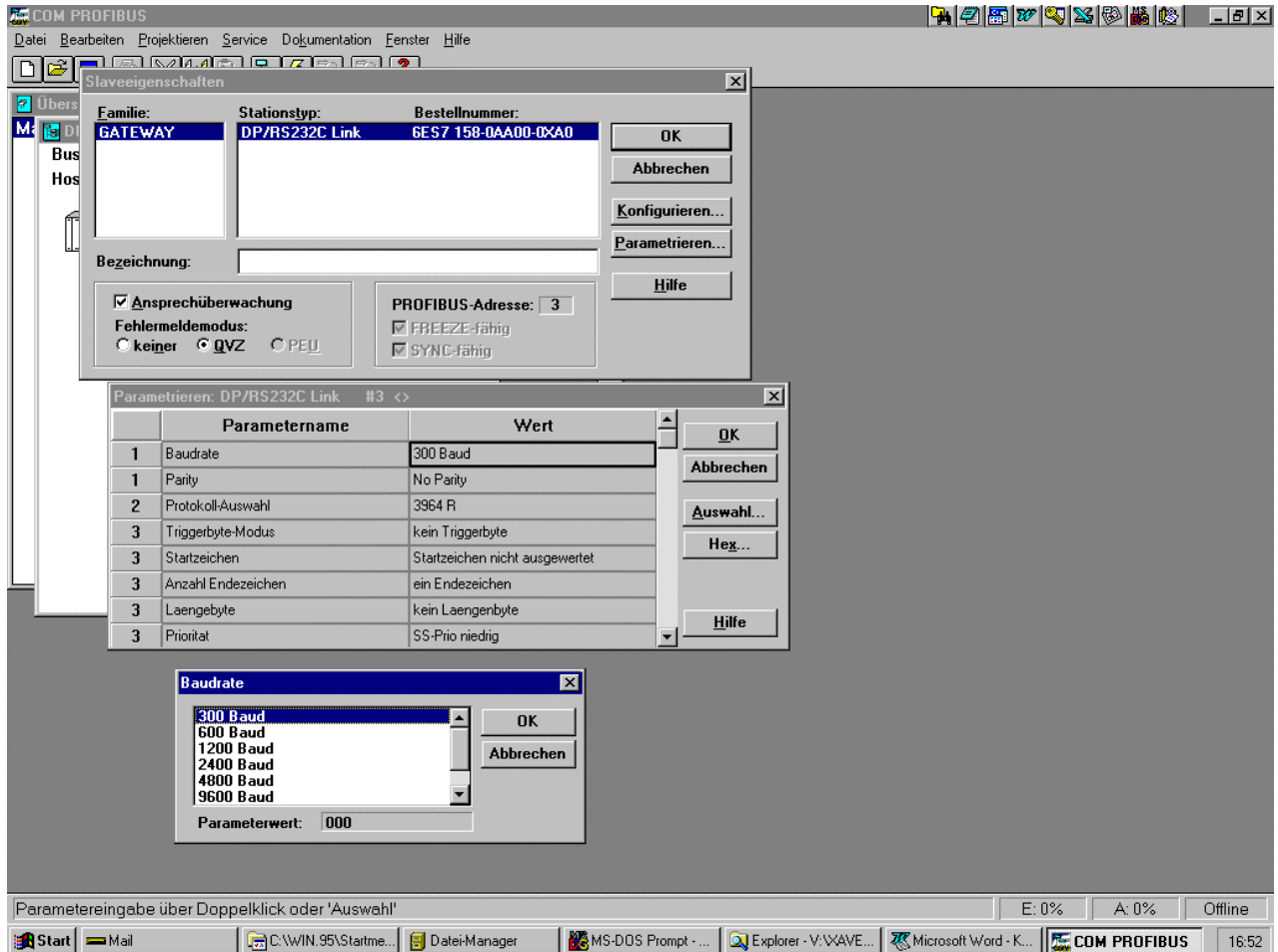

If this method is not possible the user data of the parameterization telegram is shown here.

Octet	Bitposition								Designation
	7	6	5	4	3	2	1	0	
8	0	0	0	0	0	WD_Base	Dis_Stop	Dis_Start	Spec_User_Prm_Byte_1
9	reserved		Parity		reserved	Baudrate			Spec_User_Prm_Byte_2
10	Protocol (default: 3964R)								Spec_User_Prm_Byte_3
11	Flags (default: alle 0)								Spec_User_Prm_Byte_4
12	Character delay time (TZ) (default: 200ms)								Spec_User_Prm_Byte_5
13	End delimiter								Spec_User_Prm_Byte_6
14	2nd. End delimiter								Spec_User_Prm_Byte_7
14	Start delimiter								Spec_User_Prm_Byte_8

Byte 8: Spec_User_Prm_Byte_1			
Bit	Name	Meaning	Default Status
0	Dis_Startbit	This bit is used to disable start bit monitoring on the receiver.	Dis_Startbit = 1 (i.e., start bit monitoring is disabled)
1	Dis_Stopbit	This bit is used to disable stop bit monitoring on the receiver.	Dis_Stopbit = 0 (i.e., stop bit monitoring is not disabled)
2	WD_Base	This bit specifies which time base is to be used to pulse the watchdog. WD_Base = 0: Time base of 10 msec WD_Base = 1: Time base of 1 msec	WD_Base= 0 (i.e., time base is 10 msec)
3-7	res	Must be 0	0
Byte 9: Spec_User_Prm_Byte_2			
Bit	Name	Meaning	Default Status
0,1	Parity	Setting of the parity	0= no parity, 1= even parity, 2= ODD Parity
2	Prio	Setting of the priority of the gateway	0= SS priority of gateway low 1= SS priority of gateway high For 3964R procedure only
3	Mode	Setting of the protocol	0= 3964R protocol 1= Free ASCII protocol
4 - 6	Baud	Setting of the transmission speed	0 = 300 baud 1 = 600 baud 2 = 1200 baud 3 = 2400 baud 4 = 4800 baud 5 = 9600 baud 6 = 19200 baud 7 = 38400 baud
7	Flags	3964R is to operate without timeout monitoring for test purposes.	0=Disable timeout 1= Enable timeout

Byte 10: Protocol selection	
Protocol	Value
3964R	0
Character delay time	1
Start-/End delimiter	2
Number of Characters	3
reserved	4-255

Byte 11: Flags			
Bit	Name	meaning	state
0	Trigger-Byte	Using Triggerbyte-Mode	0=no Triggerbyte 1= using Triggerbytes
1	Start character	Using Start delimiter (only Start-/End character mode)	0=switch off Start delimiter 1=switch on Start delimiter
2	2nd End delimiter	Number of end delimiters	0=one end delimiter 1=two end delimiters
3	Lengthbyte	Using the length byte	0= no length byte 1= lengthbyte is used
4	Priority	Priority during initialisation conflict (only 3964R)	0= Interface Priority is low 1= Interface Priority is high
5	Disable TO	switch off Timeout-Monitoring for test purposes	0=Timeout monitoring on 1= Timeout monitoring off
6	Send-Done-Detection	The MSB of the triggerbytes toggles each time a send-telegram has been finished . Requires Triggerbyte!	0=Send-Done-Detection off 1=Send-Done-Detection on
7	Ext_Diag disable	When communication to external device is not ok, do:	0 = set Ext_Diag 1 = do not set Ext_Diag

Byte 12: Character delay time

Character delay time 10 ms. valid range: 2 - 255 (20ms up to 2,55s)

Byte 13: End delimiter

1. character of the end delimiter

Byte 14: 2nd . End delimiter

2. character of the end delimiter

Byte 15: Start delimiter

character of the start delimiter

The response of a slave to a parameterization telegram is E5H (i.e., short acknowledge). The slave does not indicate an erroneous parameterization until the master sends a diagnostic request later. In this case, the gateway does not begin data communication.

*) The time base for the watchdog time is specified as 10 msec in octets 2 and 3. One octet should at least contain the value 2 as the time base, and the other octet should at least contain the value 1 to ensure that the watchdog time does not immediately expire. Due to 12 Mbaud technology, a time base of 1 msec is specified for some ASICs in the user parameters.

11.2 Configuration Telegram

After parameterization, the master must send a configuration telegram to the appropriate slave. After receiving the configuration telegram, the slave compares the sent configuration with the stored configuration. Up to 16 bytes or words can be written in an octet of the data unit (i.e., DU). Inputs and outputs with the same format can be combined in one octet. Otherwise, use as many octets as you have bytes/words which cannot be combined in one octet.

The acknowledgment of a configuration telegram is E5H. If the slave detects differences from the entries in the GSD file, it reports the incorrect configuration to the master when a diagnosis is requested later. In this case, the slave is not ready for user data communication.

Configuration telegram

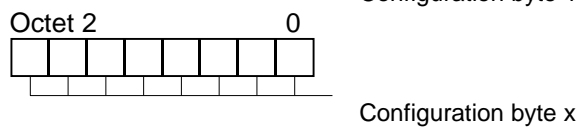
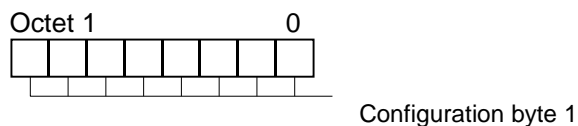

Layout of an octet in the configuration telegram:

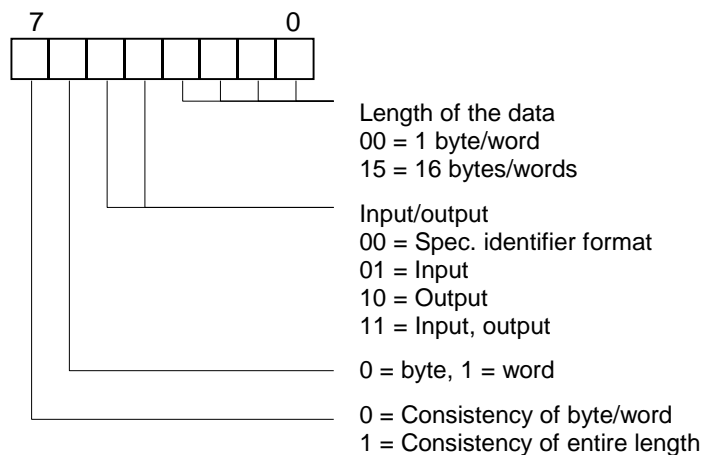

When the current configuration is unknown to a class-2 master, the master can read the configuration of the slave with "Get_Cfg" and then send it to the slave for checking. This service is particularly useful for modular systems.

11.3 Diagnosis

Diagnostic data are high-priority data. The gateway generates an external diagnosis when the connection to the external device is faulty. Additionally the Bit Ext_Diag is set if not inhibited.

Representation of the messages in the external diagnostic byte:

The diagnostic information of a DP slave consists of 6 bytes of diagnostic information and any user-related diagnostic information.

Telegram for request for diagnosis:

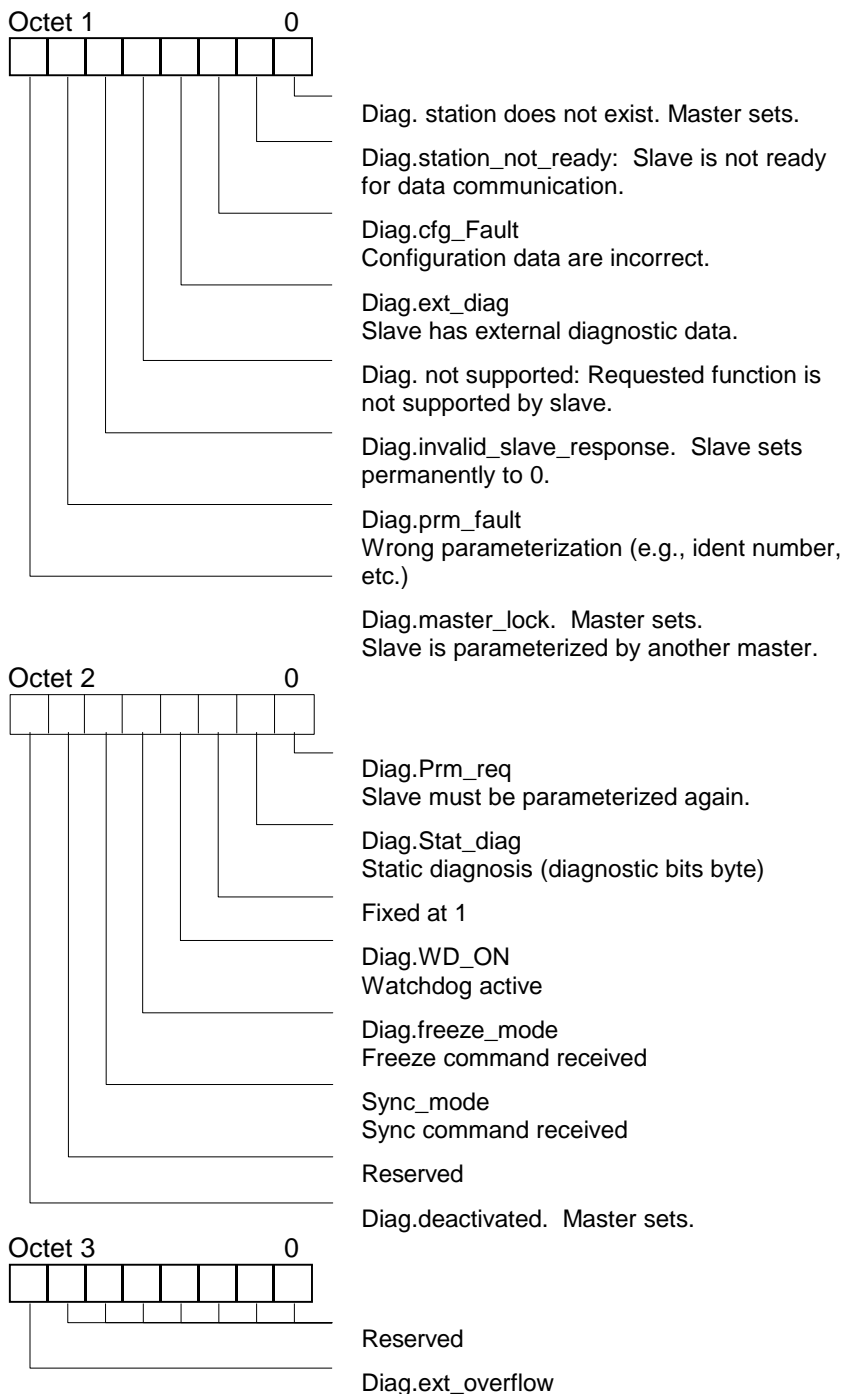

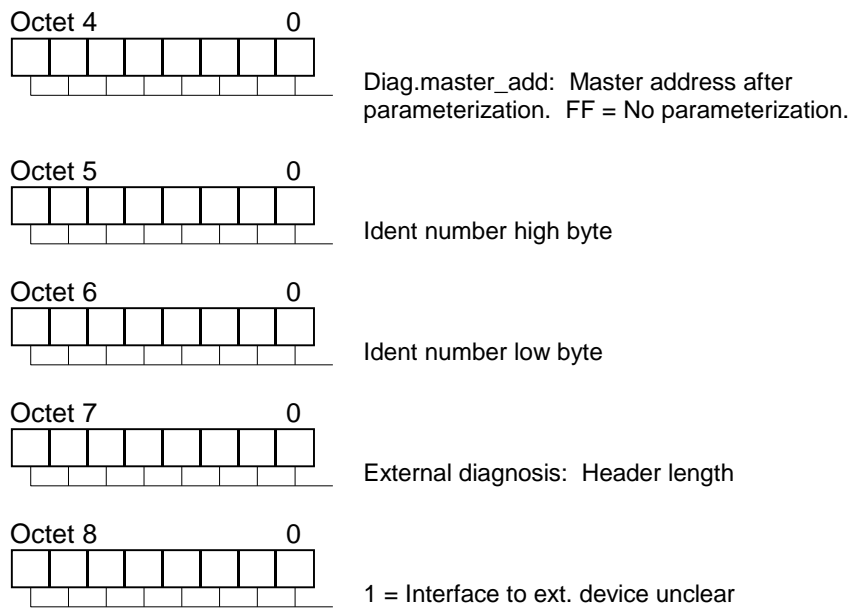

11.4 Data Exchange

After the master recognized the state for data exchange the master only sends telegrams for data exchange. The received input and output data is either stored in the dedicated area in the master or the user program has to handle the data by using Function blocks.

12 Technical Data

12.1.1 Device Data

The following table provides the technical data of the interface module.

Table 2: Technical data of the interface

No.	Parameter	Data	Explanation
1	Location of use	Switching cabinet	⇒ Mounting on top hat rail
2	Protection rating	IP20	⇒ Foreign bodies and water in acc. w. IEC 529 (DIN 40050)
3	Protection class	3	⇒ IEC 536 (VDE 0106-1) ⇒ Supplied w. low safety voltage
4	Cooling	Convection	Additional cooling not required
5	Lifespan	10 years	
6	Housing dimensions	95 mm x 70 mm x 86 mm	H x W x D
	Mounting position	Vertical Can be mounted in rows	⇒ Other mounting positions possible under reduced max. permissible operating temperature
7	Weight	0.3 kg	
8	Operating temperature	0° C ... + 60° C 0° C ... + 40° C	⇒ Vertical position is preferred. ⇒ Horizontal mounting
9	Storage/transportation temperature	- 40° C ... + 70° C	
10	Air pressure Operation Transportation	795 hPa to 1080 hPa 660 hPa to 1080 hPa	
11	Installation height	2000 m 4000 m	⇒ No restrictions ⇒ With restrictions: - Ambient temperature ≤ 40° C
12	Relative humidity	5% to 95%	⇒ SN 31205 (IEC 68-2-30) ⇒ No condensation
13	Pollutant concentration	⇒ SO ₂ < 0.5 ppm; relative humidity < 60% ⇒ H ₂ S < 0.1 ppm; relative humidity < 60%	⇒ SN 31205 (IEC 68-2-60) (= class of use : 3C3 / 1C2) ⇒ No condensation
14	Particles/dirt	⇒ Sand and dust may not penetrate the device.	
15	External supply voltage	20.4 V DC to 28.8 V DC	⇒ Standard power pack in acc. w. DIN 19240
16	Current consumption at 24 V DC	150 mA (typ.), 180 mA (max.)	
17	Powering on the PROFIBUS interface	5 V DC/ 80 mA (max.)	⇒ Suitable for connection of an OLP (Optical Link Plug)
18	Protection against polarity reversal	Yes	⇒ Device will not function anyway.
19	Short circuit protection	Yes	
20	Overload protection	Multi-fuse 0.5A	⇒ Self-restoring fuse ⇒ Reset with power OFF
21	Undervoltage recognition (UPS)	≤ 14 V DC	⇒ Min. of 50 msec until RESET
22	Power failure backup	≥ 20 msec	⇒ UPS is already triggered before at U _e < 14 V. ⇒ Device is fully functional.
23	Isolation voltage	500 V DC	⇒ IEC 1131-2

The following table lists all tests, standards and regulations to which the interface module was subjected.

Table 3: Tests, standards and regulations

No.	Parameter	Data	Explanation
1	Oscillation test	<ul style="list-style-type: none"> • $5 \text{ Hz} \leq f \leq 26 \text{ Hz}$, amplitude = 0.75 mm • $26 \text{ Hz} \leq f \leq 500 \text{ Hz}$, acceleration. = 20 m/sec² → Frequency pass: 1 octave/min → 10 frequency passes in x, y, z	⇒ SN 31205 (IEC 68-2-6-Fc sine) (= class of use : 3M6/1M4)
2	Shock test	<ul style="list-style-type: none"> • Shock form = half-sine • Acceleration = 15 g (150 m/sec²) • Shock duration = 11 msec → 3 shocks in +/- direction in x, y, z	⇒ SN 31205 (IEC 68-2-27-Ea) (= class of use : 3M6/1M4)
3	Fall test	1 m height	⇒ SN 18013
4	Bending and extraction test	<ul style="list-style-type: none"> • Screw size : M3 --> Turning moment : 0.5 to 0.8 Nm • Wire cross section : 0.75 / 1.5 / 2.5 mm² AWG : 18 / 16 / 14 • Wire form : rigid, flexible 	⇒ IEC 947-1 (screw connections)
5	Climate test: - Cold - Dry heat - Temperature change - Humidity, heat	<ul style="list-style-type: none"> • 0° C / 16 h • 60° C / 16 h • -25° C to 55° C / 1° C/min / 2 cycles • 55° C / 90 to 95% / 12+12 h / 2 cycles 	⇒ SN 31205 (IEC 68-2- 1-Ad, IEC 68-2- 2-Bd, IEC 68-2-14-Nb, IEC 68-2-30-Db) (= class of use : 3K6/1K6)
6	Pollutant concentrations	<ul style="list-style-type: none"> • SO₂ < 0.5 ppm; relative humidity < 60% • H₂S < 0.1 ppm; relative humidity < 60% 	⇒ SN 31205 (IEC 68-2-60) (= class of use : 3C3 / 1C2) ⇒ No condensation
7	ESD	8 kV Air discharge 6 kV Contact discharge	IEC 1000-4-2 Accuracy 3
8	Electromagnetic fields	10 V/m	IEC 1000-4-3 Accuracy 3
9	BURST	2 kV / 5 kHz supply voltage 2 kV / 5 kHz data lines	IEC 1000-4-4 Accuracy 3
10	Interference emission	Limit value class A	EN 55011
11	Certifications	<ul style="list-style-type: none"> • UL • CSA • CE seal • PROFIBUS certification 	⇒ Underwriters Laboratories ⇒ Canadian Standards Association ⇒ Certification of conformity ⇒ PROFIBUS User Organization
12	Standards, regulations	<ul style="list-style-type: none"> • DIN 40050 ; IEC 529 • VDE 0106, protection rating 3 • VDE 0160, to extent applicable • VDE 0110 - Insulation group IIIa, IIIb - Degree of soil 3 • IEC 68 • IEC 721-3-1 / -3 • IEC 1131-2 • IEC 1000-4-2 / -3/ -4/ -5/ -6 • EN 55011 , DIN VDE 0875-11 • EN 50022 • EN 61131-2 • UL 508 • CSA 22.2-14 	⇒ IP protection ratings ⇒ Protection against touch, intrinsic isolation ⇒ High-voltage plants ⇒ Insulation coordination ⇒ Envir. cond.: Measuring procedures ⇒ Envir. cond.: Definitions ⇒ PLC interface standard ⇒ EMC requirements ⇒ EMC emission ⇒ Standard rail (top hat rail) ⇒ PLC I/O devices ⇒ UL for industrial controllers ⇒ CSA for industrial devices
13	Siemens standards	<ul style="list-style-type: none"> • SN 18013 • SN 18012 • SN 36350 • SN 31205 	⇒ Packaging and fall test ⇒ Labeling of the packages ⇒ Recycling regulations ⇒ Environmental conditions

12.1.2 Interface Data

The following table lists the technical data of the interfaces on the device. The data have been obtained from the applicable standards.

Table 4: Technical data of the interfaces on the device

No	Interface Designation	PROFIBUS-DP	RS 232C
	Physical Interface	RS 485	RS 232-C
1	Standard	EIA standard	DIN 66020
2	Type of transmission	Symmetric Asynchronous Serial Semi-duplex ⇒ Differential signal	Asymmetric Asynchronous Serial Full-duplex ⇒ Level
3	Transmission procedures	Master/slave	Master/slave
4	Number of stations : - Senders - Receivers	32 32	1 1
5	Cable length: - Maximum - Depends on baud rate	1200 m 93.75 kBd → 1200 m 187.5 kBd → 1000 m 500 kBd → 400 m 1.5 MBd → 200 m >1.5 MBd → 100 m	15 m No
6	Bus topology	Line	Point-to-point
7	Transmission speed: - Maximum - Standard values	12 Mbit/sec 9.6 kbit/sec 19.2 kbit/sec 93.75 kbit/sec 187.5 kbit/sec 500 kbit/sec 1.5 Mbit/sec 3 Mbit/sec 6 Mbit/sec 12 Mbit/sec	20 kbit/sec 9.6 kbit/sec 19.2 kbit/sec
8	Sender: - Load - Max. voltage - Signal without load - Signal with load	54 Ω -7 V to 12 V ± 5 V ± 1.5 V	3 to 7 kΩ ± 25 V ± 15 V ± 5 V
9	Receiver: - Input resistance - Max. input signal - Sensitivity	12 kΩ -7 V to 12 V ± 0.2 V	3 to 7 kΩ ± 15 V ± 3 V
10	Sending oper. (SPACE): - Voltage level - Logic level	-0.2 to +0.2 V 0	+3 to +15 V 0
11	Sending pause (MARK): - Voltage level - Logic level	+1.5 to +5 V 1	-3 to -15 V 1

13 Commissioning Guidelines

Caution



The DP/RS232C interface (MLFB: **6ES7 158-0AA01-0XA0**) may only be commissioned by trained personnel under observance of safety regulations.

Components

The following components are required to commission the DP/RS232C Link interface.

- DP/RS232C Link interface
- Connection cable from the DP/ RS232C Link interface to the process
- Connection plug for connection of PROFIBUS to the interface
- PROFIBUS cable. (This cable has usually already been installed on site.)
- 24 V DC voltage supply (DIN 19240)
- Floppy disk with type or GSD file and operating instructions (enclosed with the interface)
- Configuration tool for the PROFIBUS master (COM PROFIBUS for Siemens master)

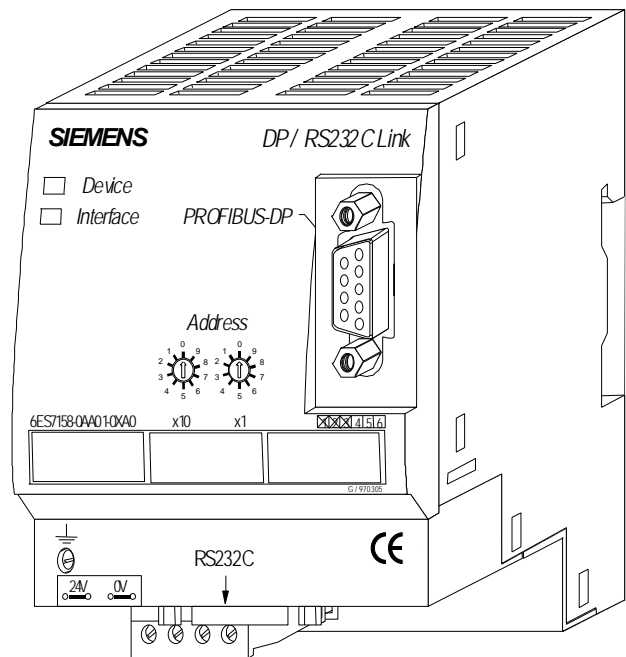

Mounting

The DP/RS232C Link interface has a protection rating of IP20 and can be installed in the switching cabinet. The device is designed to be snapped onto a 35-mm top hat rail.

Commissioning

To ensure correct operation of the interface, performance of the following commissioning steps is mandatory.

- Set PROFIBUS address
 - ⇒ Use the two rotary-type switches labeled "**Address**" on the front of the interface to set the PROFIBUS address. Use the rotary switch labeled "**x10**" to set the tens position and the rotary switch labeled "**x1**" to set the ones position.

Caution



The PROFIBUS address set with the rotary switches must match the address configured with COM PROFIBUS.

- PROFIBUS connection
 - ⇒ Connect the device to the PROFIBUS on the interface labeled "**PROFIBUS-DP**".
- Process device connection
 - ⇒ Connect the process device to the interface labeled "**RS232C**".
 - ⇒ Read the operating instructions for commissioning the process device.
- Supply voltage connection
 - ⇒ Connect the 24 V direct current to the terminals provided for this purpose.
- Shield connection
 - ⇒ Connect the protective conductor to the terminals provided for this purpose.
 - ⇒ Ground the top hat rail on which the interface was snapped on.
- Configuration with COM PROFIBUS
 - ⇒ To configure, use COM PROFIBUS (for Siemens devices) or another configuration tool suitable for the PROFIBUS master you are using. The required GSD file has already been defined.
 - ⇒ If the required GSD file was not included with your configuration tool, copy this file from the included floppy disk or download it from mailbox no. ++ 49 911 73 79 72.

14 List of Related Literature

For a quick and intensive introduction to the subject of PROFIBUS-DP and how the available ASICs operate, we recommend "The Rapid Way to PROFIBUS-DP" by Manfred Popp. The book is available from the PROFIBUS User Organization under order no. 4.071.

Address:

PROFIBUS Nutzerorganisation e.V.
Haid-und-Neu-Str. 7
76131 Karlsruhe
Tel: 0721 9658 590

