

SIEMENS

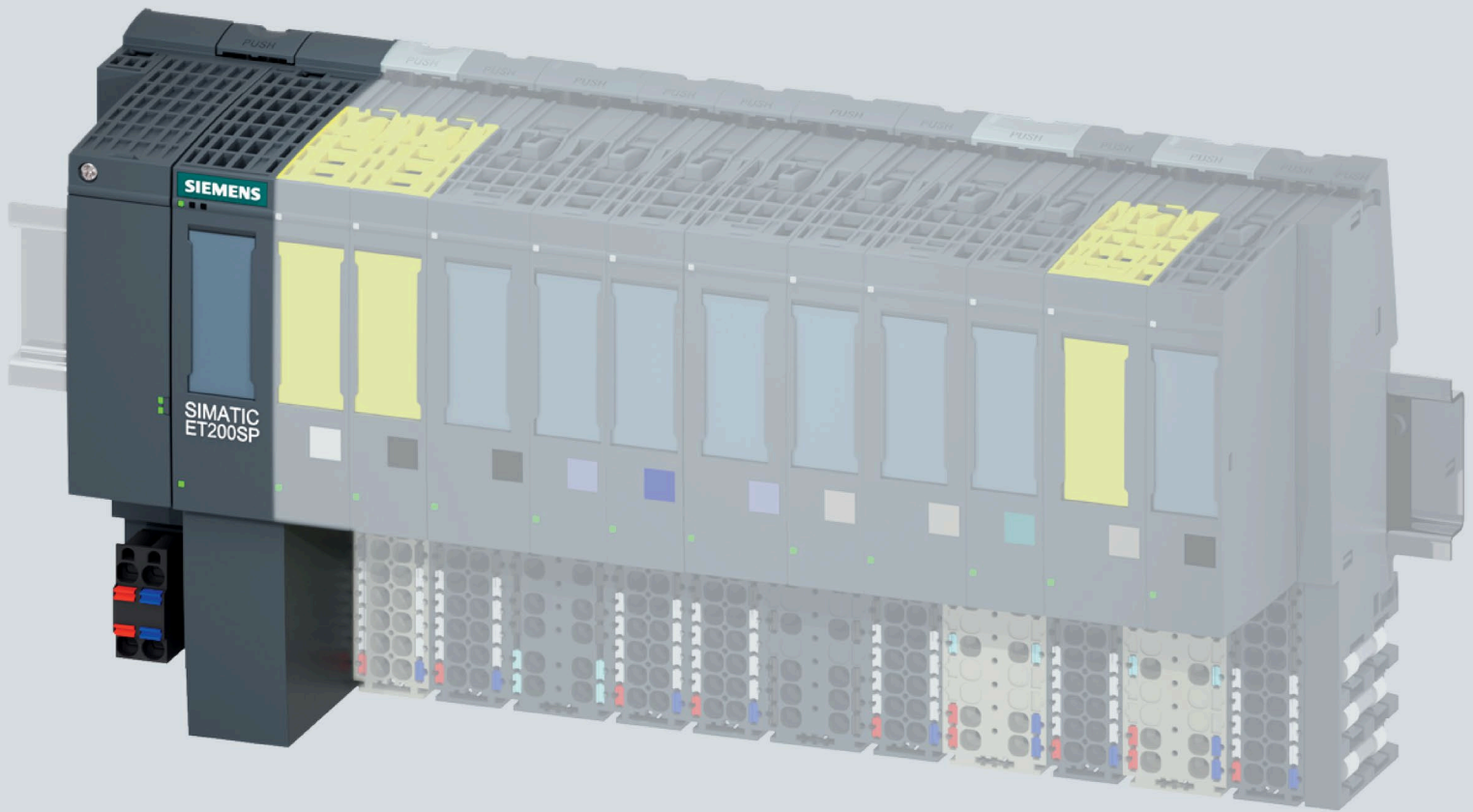

Manual

SIMATIC

ET 200SP

IM 155-6 PN ST interface module
(6ES7155-6AU01-0BNO)

Edition

10/2020

support.industry.siemens.com

SIEMENS

SIMATIC

ET 200SP IM 155-6 PN ST interface module (6ES7155-6AU01-0BN0)

Equipment Manual

Preface	
Guide	1
Product overview	2
Wiring	3
Parameters/address space	4
Interrupts, diagnostics, error, and system messages	5
Compatibility	6
Technical specifications	7
Dimension drawing	A

Legal information

Warning notice system

This manual contains notices you have to observe in order to ensure your personal safety, as well as to prevent damage to property. The notices referring to your personal safety are highlighted in the manual by a safety alert symbol, notices referring only to property damage have no safety alert symbol. These notices shown below are graded according to the degree of danger.

 DANGER
indicates that death or severe personal injury will result if proper precautions are not taken.

 WARNING
indicates that death or severe personal injury may result if proper precautions are not taken.

 CAUTION
indicates that minor personal injury can result if proper precautions are not taken.

NOTICE
indicates that property damage can result if proper precautions are not taken.

If more than one degree of danger is present, the warning notice representing the highest degree of danger will be used. A notice warning of injury to persons with a safety alert symbol may also include a warning relating to property damage.

Qualified Personnel

The product/system described in this documentation may be operated only by **personnel qualified** for the specific task in accordance with the relevant documentation, in particular its warning notices and safety instructions. Qualified personnel are those who, based on their training and experience, are capable of identifying risks and avoiding potential hazards when working with these products/systems.

Proper use of Siemens products

Note the following:

 WARNING
Siemens products may only be used for the applications described in the catalog and in the relevant technical documentation. If products and components from other manufacturers are used, these must be recommended or approved by Siemens. Proper transport, storage, installation, assembly, commissioning, operation and maintenance are required to ensure that the products operate safely and without any problems. The permissible ambient conditions must be complied with. The information in the relevant documentation must be observed.

Trademarks

All names identified by ® are registered trademarks of Siemens AG. The remaining trademarks in this publication may be trademarks whose use by third parties for their own purposes could violate the rights of the owner.

Disclaimer of Liability

We have reviewed the contents of this publication to ensure consistency with the hardware and software described. Since variance cannot be precluded entirely, we cannot guarantee full consistency. However, the information in this publication is reviewed regularly and any necessary corrections are included in subsequent editions.

Preface

Purpose of the documentation

This manual supplements the ET 200SP distributed I/O system (<http://support.automation.siemens.com/WW/view/en/58649293>) system manual.

Functions that generally relate to the system are described in this manual.

The information provided in this manual and in the system/function manuals supports you in commissioning the ET 200SP distributed I/O system.

Conventions

Please also observe notes marked as follows:

Note

A note contains important information on the product described in the documentation, on the handling of the product or on the section of the documentation to which particular attention should be paid.

Security information

Siemens provides products and solutions with industrial security functions that support the secure operation of plants, systems, machines and networks.

In order to protect plants, systems, machines and networks against cyber threats, it is necessary to implement – and continuously maintain – a holistic, state-of-the-art industrial security concept. Siemens' products and solutions constitute one element of such a concept.

Customers are responsible for preventing unauthorized access to their plants, systems, machines and networks. Such systems, machines and components should only be connected to an enterprise network or the internet if and to the extent such a connection is necessary and only when appropriate security measures (e.g. firewalls and/or network segmentation) are in place.

For additional information on industrial security measures that may be implemented, please visit (<http://www.siemens.com/industrialsecurity>).

Siemens' products and solutions undergo continuous development to make them more secure. Siemens strongly recommends that product updates are applied as soon as they are available and that the latest product versions are used. Use of product versions that are no longer supported, and failure to apply the latest updates may increase customers' exposure to cyber threats.

To stay informed about product updates, subscribe to the Siemens Industrial Security RSS Feed visit (<http://www.siemens.com/industrialsecurity>).

Table of contents

	Preface	3
1	Guide	5
2	Product overview	9
	2.1 Properties	9
	2.2 Functions	12
	2.2.1 PROFlenergy	19
	2.2.2 Use of fail-safe modules	19
	2.2.3 Use of technology modules	19
	2.2.4 Configuration control (option handling)	20
3	Wiring	21
	3.1 Pin assignment	21
	3.2 Schematic circuit diagram	22
4	Parameters/address space	23
	4.1 Parameters	23
	4.2 Explanation of parameters	23
	4.2.1 Configuration control	23
	4.3 Substitute value behavior	24
	4.4 Status of the supply voltage L+ of the I/O modules	25
5	Interrupts, diagnostics, error, and system messages	26
	5.1 Status and error displays	26
	5.2 Interrupts	30
	5.2.1 Triggering of a diagnostics interrupt	30
	5.2.2 Triggering a hardware interrupt	31
	5.2.3 Triggering a swapping interrupt	31
	5.3 Alarms	31
	5.3.1 Diagnostics alarms	31
	5.3.2 Maintenance events	32
	5.3.3 Channel diagnostics	33
	5.3.4 Invalid configuration states of the ET 200SP on PROFINET IO	37
	5.3.5 Failure of supply voltage L+ at BaseUnit BU...D	37
	5.3.6 STOP of the IO controller and recovery of the IO device	38
6	Compatibility	39
7	Technical specifications	41
A	Dimension drawing	45

The documentation for the SIMATIC ET 200SP distributed I/O system is arranged into three areas.

This arrangement enables you to access the specific content you require.

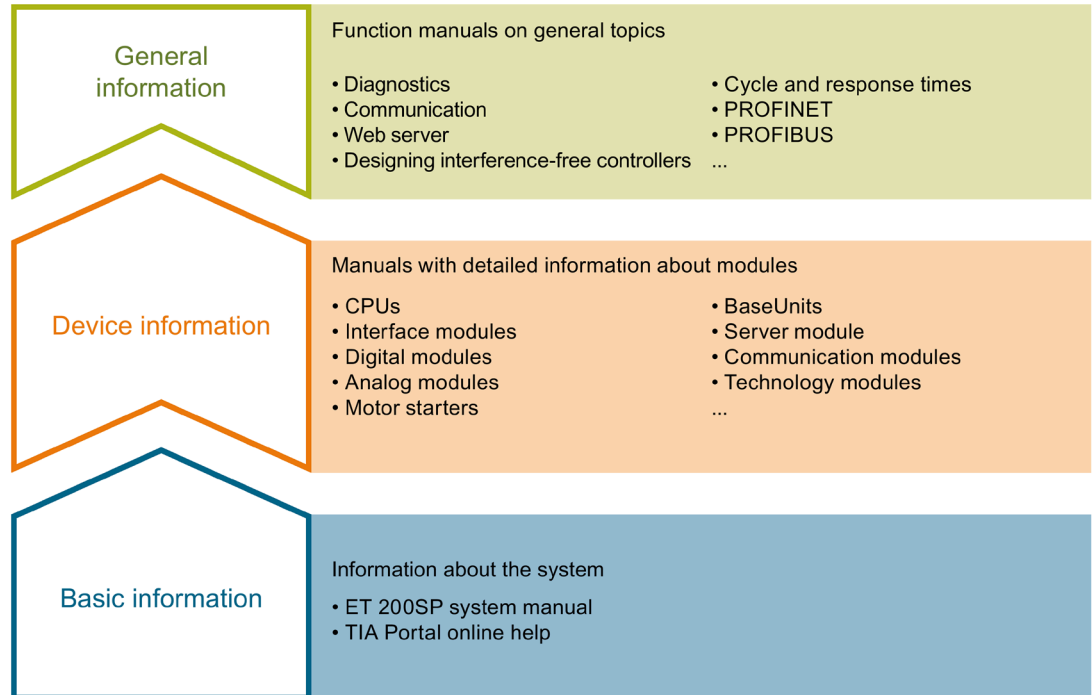

Basic information

The System Manual and Getting Started describe in detail the configuration, installation, wiring and commissioning of the SIMATIC ET 200SP distributed I/O system. The STEP 7 online help supports you in the configuration and programming.

Device information

Product manuals contain a compact description of the module-specific information, such as properties, wiring diagrams, characteristics and technical specifications.

General information

The function manuals contain detailed descriptions on general topics regarding the SIMATIC ET 200SP distributed I/O system, e.g. diagnostics, communication, Web server, motion control and OPC UA.

You can download the documentation free of charge from the Internet (<http://w3.siemens.com/mcms/industrial-automation-systems-simatic/en/manual-overview/tech-doc-et200/Pages/Default.aspx>).

Changes and supplements to the manuals are documented in a Product Information.

You can download the product information free of charge from the Internet (<https://support.industry.siemens.com/cs/us/en/view/73021864>).

Manual Collection ET 200SP

The Manual Collection contains the complete documentation on the SIMATIC ET 200SP distributed I/O system gathered together in one file.

You can find the Manual Collection on the Internet (<http://support.automation.siemens.com/WW/view/en/84133942>).

"mySupport"

With "mySupport", your personal workspace, you make the best out of your Industry Online Support.

In "mySupport", you can save filters, favorites and tags, request CAx data and compile your personal library in the Documentation area. In addition, your data is already filled out in support requests and you can get an overview of your current requests at any time.

You must register once to use the full functionality of "mySupport".

You can find "mySupport" on the Internet (<https://support.industry.siemens.com/My/ww/en>).

"mySupport" - Documentation

With "mySupport", your personal workspace, you make the best out of your Industry Online Support.

In "mySupport", you can save filters, favorites and tags, request CAx data and compile your personal library in the Documentation area. In addition, your data is already filled out in support requests and you can get an overview of your current requests at any time.

You must register once to use the full functionality of "mySupport".

You can find "mySupport" on the Internet.

"mySupport" - CAx data

In the CAx data area of "mySupport", you can access the latest product data for your CAx or CAe system.

You configure your own download package with a few clicks.

In doing so you can select:

- Product images, 2D dimension drawings, 3D models, internal circuit diagrams, EPLAN macro files
- Manuals, characteristics, operating manuals, certificates
- Product master data

You can find "mySupport" - CAx data on the Internet (<http://support.industry.siemens.com/my/ww/en/CAxOnline>).

Application examples

The application examples support you with various tools and examples for solving your automation tasks. Solutions are shown in interplay with multiple components in the system - separated from the focus on individual products.

You will find the application examples on the Internet (<https://support.industry.siemens.com/sc/ww/en/sc/2054>).

TIA Selection Tool

With the TIA Selection Tool, you can select, configure and order devices for Totally Integrated Automation (TIA).

This tool is the successor of the SIMATIC Selection Tool and combines the known configurators for automation technology into one tool.

With the TIA Selection Tool, you can generate a complete order list from your product selection or product configuration.

You can find the TIA Selection Tool on the Internet (<http://w3.siemens.com/mcms/topics/en/simatic/tia-selection-tool>).

SIMATIC Automation Tool

You can use the SIMATIC Automation Tool to perform commissioning and maintenance activities simultaneously on various SIMATIC S7 stations as a bulk operation independent of TIA Portal.

The SIMATIC Automation Tool provides a multitude of functions:

- Scanning of a PROFINET/Ethernet system network and identification of all connected CPUs
- Address assignment (IP, subnet, gateway) and station name (PROFINET device) to a CPU
- Transfer of the date and the programming device/PC time converted to UTC time to the module
- Program download to CPU
- RUN/STOP mode switchover
- CPU localization by means of LED flashing
- Reading out of CPU error information
- Reading of the CPU diagnostics buffer
- Reset to factory settings
- Firmware update of the CPU and connected modules

You can find the SIMATIC Automation Tool on the Internet (<https://support.industry.siemens.com/cs/ww/en/view/98161300>).

PRONETA

SIEMENS PRONETA (PROFINET network analysis) allows you to analyze the plant network during commissioning. PRONETA features two core functions:

- The topology overview automatically scans the PROFINET and all connected components.
- The IO check is a fast test of the wiring and the module configuration of a plant.

You can find SIEMENS PRONETA on the Internet

(<https://support.industry.siemens.com/cs/ww/en/view/67460624>).

SINETPLAN

SINETPLAN, the Siemens Network Planner, supports you in planning automation systems and networks based on PROFINET. The tool facilitates professional and predictive dimensioning of your PROFINET installation as early as in the planning stage. In addition, SINETPLAN supports you during network optimization and helps you to exploit network resources optimally and to plan reserves. This helps to prevent problems in commissioning or failures during productive operation even in advance of a planned operation. This increases the availability of the production plant and helps improve operational safety.

The advantages at a glance

- Network optimization thanks to port-specific calculation of the network load
- Increased production availability thanks to online scan and verification of existing systems
- Transparency before commissioning through importing and simulation of existing STEP 7 projects
- Efficiency through securing existing investments in the long term and the optimal use of resources

You can find SINETPLAN on the Internet.

See also

My Documentation Manager

(<http://support.industry.siemens.com/My/ww/en/documentation>)

Product overview

2.1 Properties

Article number

6ES7155-6AU01-0BN0 (IM 155-6 PN ST interface module and server module)

6ES7155-6AA01-0BN0 (IM 155-6 PN ST interface module with BusAdapter BA 2×RJ45 and server module)

View of the module

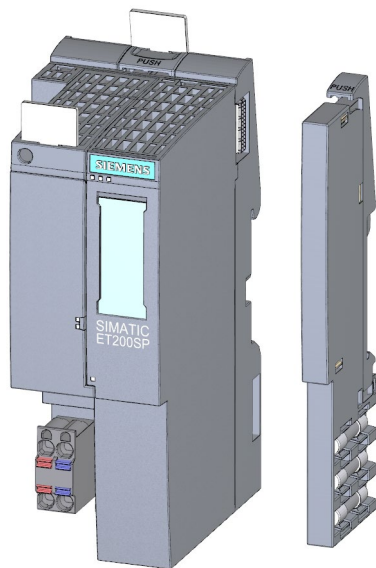

Figure 2-1 View of the IM 155-6 PN ST interface module and the server module

Properties

The module has the following technical properties:

- Connects the ET 200SP distributed I/O system with PROFINET IO
- Power supply 1 L+ 24 V DC (SELV/PELV). The connection plug is included in the scope of delivery of the interface module.
- PROFINET IO connection via selectable BusAdapter for RJ45 bus connector (BA 2×RJ45), for standard M12 connector or push-pull connector (BA 2×M12) or for direct connection of the bus cable (BA 2×FC)
- Use of fail-safe modules
- As of firmware version V 3.0, you can plug a light or a dark BaseUnit into slot 1.

2.1 Properties

The module supports the following functions (Page 12):

Maximum configuration

- 32 I/O modules
- 512 bytes I/O data
- 1 m backplane bus (without interface module)

Accessories

The following accessories can be ordered separately:

- BA 2xRJ45 BusAdapter
- BA 2xFC BusAdapter
- BusAdapter BA 2xM12
- 24 V DC connector
- Labeling strips
- Reference identification label

Note

The interface module is also available as a bundle with the BusAdapter BA 2xRJ45 (and the server module). The article number is 6ES7155-6AA01-0BN0.

A detailed list of the available accessories can be found in the system manual ET 200SP distributed I/O system (<http://support.automation.siemens.com/WW/view/en/58649293>).

Server module

The server module is included in the scope of delivery of the interface module and available separately as an accessory.

The server module has the following properties:

- Terminates the backplane bus of the ET 200SP distributed I/O system
- Features a support for 3 spare fuses (5 × 20 mm)
- Identification data I&M 0 to 3

Note

You need to configure and assign parameters to the server module in the configuration software.

To do this, place the server module in the last configuration slot and enable the parameter Group diagnostics: missing supply voltage L+. When there are 32 I/O modules, the server module is inserted in slot 33.

You can find more information in the Server module (<http://support.automation.siemens.com/WW/view/en/63257531>) manual.

First BaseUnit of an ET 200SP in the configuration (as of V3.0)

Note

First BaseUnit of an ET 200SP in the configuration

When an AC I/O module or AI Energy Meter ST is plugged, the first BaseUnit in an ET 200SP station may be a dark one. Please note the information on limiting the overvoltage and power rating in the AC I/O module manuals.

In order to route the 24 V DC supply voltage via a fuse, a light BaseUnit must be plugged into the slot of the first 24 V DC I/O module.

Pay attention to the type of the BaseUnits during the configuration.

As of firmware V3.x, the interface modules support plugging dark BaseUnits in slot 1. This means that modules without a connection to the integrated voltage buses P1 and P2 can now also be configured starting with slot 1. Currently, this applies to the following modules:

- DI 4x120..230VAC ST (6ES7131-6FD00-0BB1)
- DQ 4x24..230VAC/2A ST (6ES7132-6FD00-0BB1)

Requirement for configuration of these modules in slot 1:

- Configuration via GSD or GSDML
- Configuration as of STEP 7 V5.5 SP4 with
 - HSP0241 V2.0 for IM155-6 PN ST
- Configuration as of STEP 7 V13 SP1

2.2 Functions

Introduction

The interface module supports the following PROFINET IO functions:

- Integrated switch with 2 ports
- Supported Ethernet services: ping, arp, SNMP, LLDP
- Port diagnostics
- Disabling ports
- Isochronous real-time communication
- Minimum update time 1 ms
- Prioritized startup
- Media redundancy (MRP)
- Shared device
- Support of submodules on suitable I/O modules
- Module-internal Shared Input/Shared Output (MSI/MSO)
- Device replacement without PG and without topological configuration
- Reset to factory settings via PROFINET IO
- Firmware update via PROFINET IO
- Station extension via ET-Connection
- The BusAdapter provides the connection system for PROFINET IO. The following versions are available for the IM 155-6 PN ST interface module:
 - For standard RJ45 connector: BA 2×RJ45
 - For direct connection of the bus cable: BA 2×FC
 - For standard M12 connector or push-pull connector BA 2×M12

The interface module supports additional functions:

- Identification data I&M 0 to 3
- PROFINergy
- Use of fail-safe modules
- Configuration control (option handling)
- Value status (quality information, QI) of I/O modules

Note

Docking system

Do **not** use the IM155-6 PN ST interface module as a docking station. The use as a docking unit (function: IO devices changing during operation) in a docking system is supported.

Requirements

The table below shows the software requirements for a configuration with the IM 155-6 PN ST interface module:

Table 2- 1 Version dependencies of other module functions

Function	Product version of the module as of	Firmware version of the module as of	Configuration software		
			Configuration with GSD file (http://support.automation.siemens.com/WW/view/en/19698639/130000)/software from a third-party manufacturer ¹	STEP 7 as of V5.5 SP3 with HSP241	STEP 7 (TIA Portal), as of V11 SP2
Real-time communication	1	V1.0.0	X	X	X
Isochronous real-time communication	1	V1.0.0	X	X	X
Prioritized startup	1	V1.0.0	X	X	X
Device replacement without programming device	1	V1.0.0	X	X	X
Media redundancy (MRP)	1	V1.0.0	X	X	X
Shared device	1	V1.0.0	X	X	X (as of V13 SP1)
PROFenergy	1	V1.0.0	---	X	X
Use of fail-safe modules	1	V1.0.1	X	X	X (as of V13 SP1)
Module-internal Shared Input/Shared Output (MSI/MSO)	1	V3.1.0	X	X	X (as of V13 SP1)
Station extension via ET-Connection	5	V3.1.0	X	X	X (as of V13 SP1)
User data 512 bytes	1	V3.1.0	X	X	X (as of V13 SP1)
Distribution of module channels to multiple submodules	1	V3.3.0	X	X (as of V5.5 SP4, HSP0241 V3)	X (as of V13 SP1, Update 6)
Interface module; article number: 6ES7155-6AU01-0BNO	1	V4.1	X	X (as of V5.5 SP4 HSP241 V4)	X (as of V14 HSP205)
BusAdapter BA 2xMA12	1	V4.2	X	-	X (as of V16 Update 1)

¹ Systems of third-party manufacturers: Depending on the range of functions of the third-party system

Note

BusAdapter BA 2xMA12 and firmware 4.1

When using a BA 2xMA12 BusAdapter and firmware 4.1, note that an update to version V4.2 via another BusAdapter must first be performed to make the IM executable.

Cabling with fixed connection setting

If you set a fixed connection setting of the port in STEP 7, you must also disable "Autonegotiation/Autocrossover".

You can find more information on this topic in the STEP 7 online help and:

- As of STEP 7 V12 in the PROFINET with STEP 7 V13 (<http://support.automation.siemens.com/WW/view/en/49948856>) function manual
- As of STEP 7 V5.5 in the PROFINET System Description (<http://support.automation.siemens.com/WW/view/en/19292127>) system manual

Isochronous real-time communication

Synchronized transmission method for cyclic exchange of IRT data between PROFINET devices. A reserved bandwidth within the send clock is available for IRT data. The reserved bandwidth ensures that the IRT data is also transmitted in time-synchronized intervals, unaffected by other high network loading (e.g. TCP/IP communication or additional real time communication).

A topological configuration is required for IRT.

Note

IO controller as sync master with IRT communication

We recommend operating the IO controller also as a sync master when configuring the IRT communication.

Otherwise, IRT- and RT-configured IO devices may fail if the sync master fails.

You can find more information on the configuration of synchronized PROFINET devices in sync domains in the STEP 7 online help and:

- As of STEP 7 V12 in the PROFINET with STEP 7 V13 (<http://support.automation.siemens.com/WW/view/en/49948856>) function manual
- As of STEP 7 V5.5 in the PROFINET System Description (<http://support.automation.siemens.com/WW/view/en/19292127>) system manual

Prioritized startup

Prioritized startup is a PROFINET IO function in a PROFINET IO system with IRT and RT communication. It reduces the time needed for correspondingly configured IO devices to return to cyclic user data exchange.

This function accelerates the startup of IO devices in the following cases:

- After recovery of supply voltage
- After station recovery
- After activation of IO devices

Note

Dependency of the startup time

The interface module permits startup times from 0.9 s.

The startup time depends on the number and type of modules.

You can find more information on this topic in the STEP 7 online help and:

- As of STEP 7 V12, in the function manual PROFINET with STEP 7 V13 (<http://support.automation.siemens.com/WW/view/en/49948856>)
- As of STEP 7 V5.5 in the PROFINET System Description (<http://support.automation.siemens.com/WW/view/en/19292127>) system manual

Device replacement

Device replacement without topological configuration

The device name is also stored on the BusAdapter in addition to the interface module. A device name saved on the BusAdapter is the requirement for device replacement without topological configuration.

When the interface module is replaced, there is range of scenarios in which the device name is used.

Table 2- 2 Scenarios for using the device name

	Interface module empty	Interface module with device name
BusAdapter empty	No device name available	The device name from the interface module is used and copied to the BusAdapter.
BusAdapter with device name	The device name from the BusAdapter is used and copied to the interface module.	The device name from the BusAdapter is used and copied to the interface module if this has a different device name.

Be aware of the following constraints:

- Resetting to factory settings deletes the device name in both the interface module and the BusAdapter. To prevent the device name from being deleted in the BusAdapter, you can remove the BusAdapter from the interface module before resetting to factory settings.
- When a BusAdapter is replaced, a device name stored in the BusAdapter is applied to the interface module after a POWER ON.
- Do not pull/plug the BusAdapter while under voltage. If you pull/plug the BusAdapter while under voltage, the interface module restarts.

Device replacement with topological configuration

IO devices with this function can be replaced in a simple manner:

- The device name does not have to be assigned with the programming device.

The replacement IO device is assigned the device name by the IO controller and not by the programming device. The IO controller uses the configured topology and the neighboring relationships determined by the IO devices for this purpose. All involved devices must support the LLDP protocol (Link Layer Discovery Protocol). The configured target topology must match the actual topology.

If the IO devices were already used in another configuration, reset them to factory settings before reusing them. You can find information on this in the ET 200SP distributed I/O system (<http://support.automation.siemens.com/WW/view/en/58649293>) system manual.

You can find more information on this topic in the STEP 7 online help and:

- As of STEP 7 V12 in the PROFINET with STEP 7 V13 (<http://support.automation.siemens.com/WW/view/en/49948856>) function manual
- As of STEP 7 V5.5 in the PROFINET System Description (<http://support.automation.siemens.com/WW/view/en/19292127>) system manual

Replacement of an IM 155-6 PN ST

In a replacement scenario, you reset an IO device that is already in operation to the as-delivered state using "Reset to factory settings". You can find more information in the ET 200SP distributed I/O system (<http://support.automation.siemens.com/WW/view/en/58649293>) system manual.

Media redundancy (MRP)

Function for safeguarding communication and plant availability. A ring topology ensures that an alternative communication path is made available if a transmission route fails.

You can find more information on this topic in the STEP 7 online help and:

- As of STEP 7 V12, in the function manual PROFINET with STEP 7 V13 (<http://support.automation.siemens.com/WW/view/en/49948856>)
- As of STEP 7 V5.5 in the PROFINET System Description (<http://support.automation.siemens.com/WW/view/en/19292127>) system manual

Shared device

IO device which makes its data available to multiple IO controllers.

The interface module supports shared device at submodule level.

If **there is no validity check of the shared device projects by the Engineering System**, note the following:

- Make sure the configurations are consistent. Assign each module or submodule to only one IO controller. Multiple assignment causes errors because the module or submodule is only available in the first controller.
- If you reconfigure the shared device configurations without the validity check mentioned above, you must commission ET 200SP again. This means you must download the projects of all involved IO controllers to the respective CPU again after reconfiguration. If necessary, perform a POWER OFF/POWER ON of the interface module.

You can find more information on this topic in the STEP 7 online help and:

- As of STEP 7 V12, in the function manual PROFINET with STEP 7 V13 (<http://support.automation.siemens.com/WW/view/en/49948856>)
- As of STEP 7 V5.5 in the PROFINET System Description (<http://support.automation.siemens.com/WW/view/en/19292127>) system manual

Note

In the case of a shared device application, make sure that all controllers work with the same send clock. If the controller does not have the same send clock, this results in communication relationships not being set up.

If you set up all controllers in one project, the same send clock is ensured. Set the same send clock for engineering in separate projects.

Submodules

The IM 155-6 PN ST interface module supports the division of I/O modules into up to 4 submodules. This allows parts of an I/O module to be separately configured and parameterized.

You can assign each of these submodules to different IO controllers.

The following functions are only executed if you have configured submodule 1 during configuration:

- Firmware update
- Write I&M data
- Calibration
- PROFlenergy

Module-internal Shared Input/Shared Output (MSI/MSO)

The Module-internal Shared Input function allows an input module to make its input data available to up to two IO controllers (for ET 200SP PN ST). Each controller has read access to the same channels.

The Module-internal Shared Output function allows an output module to make its output data available to up to two IO controllers. One IO controller has write access. A second IO controller can have read access to the same channels.

You can find more information on this topic in the STEP 7 online help and:

- As of STEP 7 V12 in the PROFINET with STEP 7 V13 (<http://support.automation.siemens.com/WW/view/en/49948856>) function manual

Value status

The IM 155-6 PN ST interface module supports I/O modules with value status.

Additional information on the value status can be found in the manuals for the I/O modules.

GSD file

An additional GSD file based on the schema version V2.25 is available for the previous PROFINET GSD files. This is only to be used when the engineering tool used does not support GSD files of the current schema version.

These limitations must be taken into account when using the GSD file with the schema version V2.25 compared to the GSD file of the current schema version:

- Only IM 155-6 PN ST with the firmware version V4.2 can be configured with GSD V2.25. Only the IM 155-6 PN ST with firmware V4.2 and compatible successors can be used.
- Functionally, there are the following differences:
 - No support for S2 system redundancy
 - No support of fail-safe modules
 - No assignment of hardware interrupts to organization blocks (OB)
 - IRT including PerformanceUpgrade is not supported
 - PROFIenergy is not supported on module level (can only still be used on IM)
 - No support for MRPD, MRT
 - No hierarchical display in the parameter masks
 - No configuration check with automatic device naming with topological configuration
 - StartupMode: No AdvancedStartup, only the Legacy Mode is supported.

2.2.1 PROFlenergy

Properties

PROFlenergy (for PROFINET) reduces the energy consumption by using PROFlenergy commands during production-free periods.

Reference

You can find more information on PROFlenergy in the:

- Product manual I/O modules (<http://support.automation.siemens.com/WW/view/en/55679691/133300>)
- PROFINET with STEP 7 V13 (<http://support.automation.siemens.com/WW/view/en/49948856>) function manual.
- System manual PROFINET system description (<http://support.automation.siemens.com/WW/view/en/19292127>)
- PROFlenergy (<http://support.automation.siemens.com/WW/view/en/66928686>) product information.
- Internet (<http://www.profibus.com>) under Common Application Profile PROFlenergy; Technical Specification for PROFINET; Version 1.0; January 2010; Order No: 3.802.

2.2.2 Use of fail-safe modules

Properties

The IM 155-6 PN ST interface module as of firmware V1.0.1 supports the use of fail-safe modules.

Reference

You can find more information in the ET 200SP distributed I/O system (<http://support.automation.siemens.com/WW/view/en/58649293>) system manual.

2.2.3 Use of technology modules

Technology modules

As of firmware version V3.1, the interface module IM 155-6 PN ST supports the "Position input for Motion Control" mode of the technology modules TM Count 1x24V (6ES7138-6AA00-0BA0) and TM PosInput 1 (6ES7138-6BA00-0BA0).

2.2.4 Configuration control (option handling)

Properties

Configuration control allows you to prepare your distributed I/O system for future extensions or changes. Configuration control means that you can configure the planned maximum configuration of your distributed I/O system in advance and vary it later in a flexible manner by means of the user program.

Reference

You can find more information on configuration control

- in the ET 200SP distributed I/O system
(<http://support.automation.siemens.com/WW/view/en/58649293>) system manual
- on the Internet under the following link: Application collection
(<http://support.automation.siemens.com/WW/view/en/29430270>)
- in the STEP 7 online help.

Wiring

3.1 Pin assignment

24 V DC supply voltage (X80)

Table 3- 1 Pin assignment 24 V DC supply voltage

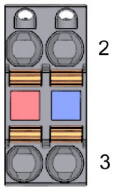
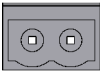
View		Signal name ¹⁾		Description
Connector	IM connection			
		1	1L+	+ 24 V DC of the supply voltage
		2	1M	Ground of the supply voltage
		3	2M	Ground of the supply voltage for loop-through ²⁾
		4	2L+	+ 24 V DC of the supply voltage for loop-through ²⁾

¹⁾ 1L+ and 2L+ as well as 1M and 2M are bridged internally

²⁾ Maximum 10 A permitted

Reference

You can find more information on accessories and how to connect the interface module in the ET 200SP distributed I/O system (<http://support.automation.siemens.com/WW/view/en/58649293>) system manual.

3.2 Schematic circuit diagram

The following figure shows a block diagram of the IM 155-6 PN ST interface module.

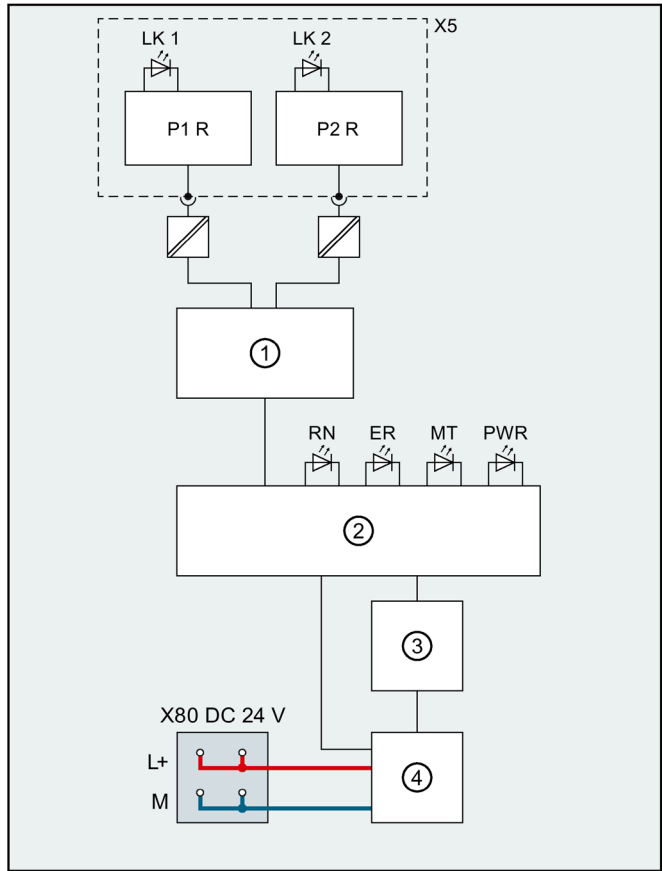

①	Switch	L+	24 V DC supply voltage
②	ET 200SP backplane bus interface and electronics	M	Mass
③	Backplane bus	LK 1,2	TX/RX Link LED
④	Internal power supply	RN	RUN LED (green)
X80 24 V DC	Supply voltage infeed	ER	ERROR LED (red)
X5	BusAdapter	MT	MAINT LED (yellow)
P1 R	PROFINET interface X1 Port 1	PWR	POWER LED (green)
P2 R	PROFINET interface X1 Port 2		

Figure 3-1 Block diagram of the IM 155-6 PN ST interface module

Parameters/address space

4.1 Parameters

Parameters for IM 155-6 PN ST interface module

The following table shows the parameters for the IM 155-6 PN ST interface module.

Table 4- 1 Parameters for interface module IM 155-6 PN ST (GSD file)

Parameters	Value range	Default	Efficiency range
Configuration control	Disable/enable	Disable	ET 200SP

4.2 Explanation of parameters

4.2.1 Configuration control

You can use this parameter to enable the configuration control function in the ET 200SP distributed I/O system.

Note

If you configure the enable, the ET 200SP distributed I/O system requires a control data record 196 from the user program in order for the ET 200SP distributed I/O system to operate the I/O modules.

Reference

You can find more information in the ET 200SP distributed I/O system (<http://support.automation.siemens.com/WW/view/en/58649293>) system manual and in the STEP 7 online help.

4.3 Substitute value behavior

The substitute value behavior in the ET 200SP distributed I/O system is executed by the IO controller for each slot.

The respective output behaves according to its configured substitute value behavior:

- Current-free/voltage-free
- Output substitute value
- Keep last value

The substitute value behavior is triggered in the following cases:

- STOP controller
- Controller failure (connection interrupted)
- Firmware update
- Reset to factory settings
- Station stop, for example, due to:
 - Missing server module
 - Removing more than one I/O module at a time.
 - At least one I/O module installed on an incorrect BaseUnit
- Deactivating the IO device

Note

Reducing a configuration

If you reduce the configuration of the ET 200SP distributed I/O system and download the configuration to the CPU, the modules which are no longer configured but still present retain their original substitute value behavior. This applies until the supply voltage is switched off at the interface module.

The "current-free/voltage-free" behavior takes effect in the following cases:

- Firmware update
- Reset to factory settings
- Configuration control: The IM has not received a valid control data record 196 yet.
- Incorrectly configured module
- Module with incorrect parameter assignment

4.4 Status of the supply voltage L+ of the I/O modules

Introduction

The "Status of the supply voltage L+ of the I/O modules" is configured on the server module as of IM 155-6 PN ST V1.1.x and GSD file 04/2013. The input data can then be read out on the server module. You will find the relevant description in the Server module (<http://support.automation.siemens.com/WW/view/en/63257531>) device manual.

Configurations

You can select two configurations for the IM 155-6 PN ST or the server module of the IM 155-6 PN ST in the configuration software:

- Configuration without input data
- Configuration with input data

Input data

You can read out the status of the supply voltage L+ for each I/O module of the ET 200SP in the input data (byte 0 to 3).

	7	6	5	4	3	2	1	0	
Byte 0	8	7	6	5	4	3	2	1	Slots of the I/O modules
Byte 1	16	15	14	13	12	11	10	9	Bit = 0: Supply voltage L+ missing or I/O module not installed
Byte 2	24	23	22	21	20	19	18	17	Bit = 1: Supply voltage L+ and I/O module available
Byte 3	32	31	30	29	28	27	26	25	

Figure 4-1 Status of the supply voltage L+

Note

An inserted or missing server module always signals "bit = 0" for the slot.

Interrupts, diagnostics, error, and system messages

5

5.1 Status and error displays

LED display

The following diagram shows the LED display on the interface module and the BusAdapter.

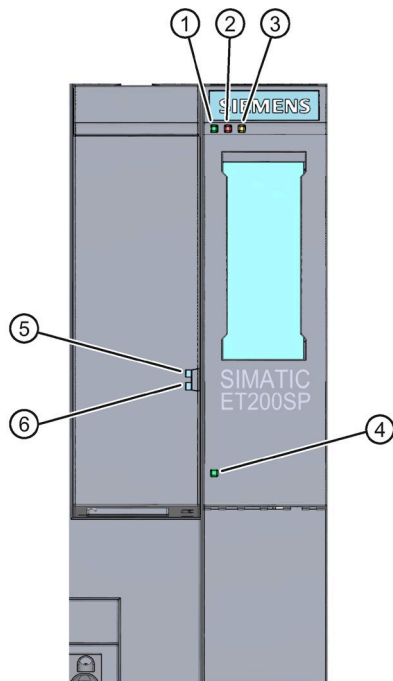

- ① RN (green)
- ② ER (red)
- ③ MT (yellow)
- ④ PWR (green)
- ⑤ LK1 (green)
- ⑥ LK2 (green)

Figure 5-1 LED display on the interface module and BusAdapter

Meaning of the LEDs

The meaning of the status and error messages is described in the following tables.

RN/ER/MT LED on the interface module

Table 5- 1 RN/ER/MT status and error displays

LEDs			Meaning	Remedy
RN (RUN)	ER (ERROR)	MT (MAINT)		
□ Off	□ Off	□ Off	Missing or insufficient supply voltage on interface module.	Check the supply voltage or turn in on at the interface module. *
■ On	■ On	■ On	Test of LEDs during startup: The three LEDs light up simultaneously for approximately 0.25 s.	-
⚡ Flashes	□ Off	□ Off	Interface module is deactivated.	Activate the interface module with the configuration software or the user program.
			Interface module is not configured.	Configure the interface module with the configuration software.
			ET 200SP starts up.	-
			ET 200SP is configured.	-
			ET 200SP is reset to factory settings.	
■ On	Not relevant	Not relevant	ET 200SP is currently exchanging data with the IO controller.	
Not relevant	⚡ Flashes	Not relevant	Group errors and group error channels.	Evaluate the diagnostics data and remedy the error.
			The configured structure does not correspond to the actual structure of the ET 200SP .	Check the structure of the ET 200SP to see whether a module is missing or defective, or whether a non-configured module is plugged.
			Invalid configuration states.	See section Invalid configuration states of the ET 200SP on PROFINET IO (Page 37)
			Parameter error in the I/O module.	Evaluate the display of the module status in STEP 7 and eliminate the error in the respective I/O module.
Not relevant	Not relevant	■ On	Maintenance	See section Maintenance events (Page 32)
⚡ Flashes	⚡ Flashes	⚡ Flashes	The "Node flash test" is run (the LEDs LK1 and LK2 of the PROFINET interface also flash).	-
			Hardware or firmware defective (the LEDs LK1 and LK2 of the PROFINET interface do not flash).	Run a firmware update. If the error persists, contact Siemens Industry Online Support. Replace the interface module.

* PWR LED on (on the interface module): Check the backplane bus for a short circuit.

PWR LED on the interface module

Table 5- 2 PWR status display on the interface module

PWR LED	Meaning	Remedy
□ Off	Supply voltage not present or too small	Check the supply voltage.
■ On	Supply voltage present	-

LK1/LK2 LED on the BusAdapter

Table 5- 3 LK1/LK2status display on the BusAdapter

LEDs LK1/LK2	Meaning	Remedy
□ Off	There is no Ethernet connection between the PROFINET IO interface of your PROFINET device and a communication partner (e.g. IO controller).	Check whether the bus cable to the switch/IO controller is interrupted.
■ On	There is an Ethernet connection between the PROFINET IO interface of your PROFINET device and a communication partner (e.g. IO controller).	-
⚡ Flashes	The "Node flash test" is run (the RN/ER/MT LEDs also flash).	-

LED display of configuration errors

Configuration errors of the ET 200SP distributed I/O system are output on the interface module by the ERROR (red) and MAINT (yellow) LEDs.

The following configuration errors are indicated by the LEDs:

- More than one I/O module pulled
- Missing server module
- Interruptions or short circuit on the backplane bus

Principle of operation

You determine the information for cause of the error with the LED error display. After notification by the flash signal, the error type is displayed followed by the error location/error code.

The LED error display

- is active during POWER ON as well as during operation.
- has priority before all other states displayed by the ERROR and MAINT LED.
- remains turned on until the cause of the error has been corrected.

Table 5- 4 Display of error type and error location

Sequence		Description
1	The ERROR and MAINT LEDs flash 3x at 0.5 Hz	Signaling of error type
2	MAINT LED flashes at 1 Hz	Display of the error type (decimal)
3	The ERROR and MAINT LEDs flash 3x at 2 Hz	Signaling of error location/error code
4	The ERROR LED flashes at 1 Hz	Display of tens digit (decimal) of the error location/error code
5	The MAINT LED flashes at 1 Hz	Display of ones digit (decimal) of the error location/error code
6	Repeat steps 1 to 5 until the cause of the error has been corrected.	

Error display

The following table shows the possible causes of error that can occur.

Table 5- 5 Error display

Error type (MAINT)	Error location (ERROR/MAINT)	Cause of error	Remedy
1	02 to 32*	The number of pulled I/O modules is displayed. The diagnostics data is generated starting with two pulled I/O modules.	Check the configuration of the ET 200SP.
	65*	<ul style="list-style-type: none"> Missing server module Interruptions at the backplane bus Short circuit of communication on the backplane bus 	

* Slot

Note

A short circuit in the backplane bus supply or the bus connection supply is indicated by the following LEDs:

- PWR LED: On
- RN-, ER and MT LED: Off

5.2 Interrupts

Introduction

The I/O device generates interrupts as a reaction to specific error events. Interrupts are evaluated based on the I/O controller used.

Evaluating interrupts with I/O controllers

The ET 200SP distributed I/O system supports the following interrupts:

- Diagnostics interrupts
- Hardware interrupts
- Swapping interrupts
- Maintenance events

In the event of an interrupt, interrupt OBs are automatically called in the CPU of the IO controller.

Information on the cause and class of the error is already available, based on the OB number and start information.

Detailed information on the error event can be obtained in the error OB using the instruction "RALRM" (read additional interrupt information).

System diagnostics

In STEP 7 (TIA Portal), the updated system diagnostics is available for the devices of the S7-1500 automation system (IO controller S7-1500 CPU) and ET 200SP (IO device). Independent of the cyclic user program, messages are made available on the display of the CPU S7-1500, the CPU web server and the HMI device.

You will find more information on system diagnostics in the Diagnostics (<http://support.automation.siemens.com/WW/view/en/59192926>) function manual.

5.2.1 Triggering of a diagnostics interrupt

Triggering of a diagnostics interrupt

For an incoming or outgoing event (e.g. wire break on a channel of an I/O module), the module triggers a diagnostics interrupt if this is configured accordingly.

The CPU interrupts the user program and processes the diagnostics block OB 82. The interrupt triggering event is logged in the start information of OB 82.

5.2.2 Triggering a hardware interrupt

Triggering a hardware interrupt

If there is a process interrupt, the CPU interrupts user program execution and processes the process interrupt block OB 40. The result that triggered the interrupt is added to the start information of the hardware interrupt block.

Note

Diagnostics "Hardware interrupt lost" (from I/O module)

Avoid creating hardware interrupts cyclically.

If the hardware interrupt load is too high, hardware interrupts can get lost depending on the number of I/O modules and the communication load.

5.2.3 Triggering a swapping interrupt

Triggering a swapping interrupt

If there is a swapping interrupt, the CPU interrupts user program execution and processes the process interrupt block OB 83. The result that triggered the interrupt is added to the start information of OB 83.

5.3 Alarms

5.3.1 Diagnostics alarms

Actions after a diagnostics alarm

There can be more than one diagnostic alarm at a given time. Each diagnostics alarm initiates the following actions:

- The ERROR LED of the interface module flashes.
- Diagnostics are reported as diagnostic error interrupts to the CPU of the IO controller and can be read via data records.
- Incoming diagnostics alarms are saved to the diagnostics buffer of the I/O controller.
- OB 82 is called. If OB 82 is not available, the I/O controller goes into STOP mode.

You can find more information in the STEP 7 online help.

Reading the diagnostics

Table 5-6 Reading the diagnostics with STEP 7

Automation system with IO controller	Application	See...
SIMATIC S7	Diagnostics as plain text in STEP 7 using Online and Diagnostics view	STEP 7 online help <ul style="list-style-type: none"> as of STEP 7 V12 function manual PROFINET with STEP 7 V13 (http://support.automation.siemens.com/WW/view/en/49948856) as of STEP 7 V5.5 system manual PROFINET System Description (http://support.automation.siemens.com/WW/view/en/19292127)
	Instruction "RDREC" (SFB 52) Read data records from the IO device	
	Instruction "RALRM" (SFB 54) Receive interrupts from the IO device	

Additional information on the data records for PROFINET IO

The structure of the diagnostic data records and programming examples are available in the programming manual From PROFIBUS DP to PROFINET IO (<http://support.automation.siemens.com/WW/view/en/19289930>) and in Example application (<http://support.automation.siemens.com/WW/view/en/24000238>).

Causes of error and troubleshooting

The causes of error and remedies for the diagnostics alarms are described in the Product Manuals for I/O modules (<http://support.automation.siemens.com/WW/view/en/55679691/133300>) in the section, "Interrupts/diagnostics alarms".

See also

Channel diagnostics (Page 33)

5.3.2 Maintenance events

Triggering of a maintenance event

The PROFINET IO interfaces of the interface module support the diagnostic concept and maintenance concept in PROFINET IO according to the IEC 61158-6-10 standard. The goal is to detect and remove potential problems as soon as possible.

For the interface module, maintenance events signal to the user when a network component must be checked or replaced.

The CPU interrupts user program execution and processes the diagnostic block OB 82. The event that triggered the maintenance event is entered in the start information of the OB 82.

The interface module signals a maintenance event to the higher-level diagnostic system in the case of the following events:

Table 5- 7 Triggering of a maintenance event

Maintenance alarm	Event	Meaning
Maintenance demanded (<i>maintenance demanded</i>) LED MAINT is lit.	Synchronization loss	<ul style="list-style-type: none"> No synchronization frame received No synchronization frame was received by the sync master within the timeout period after parameter assignment or during operation. Successive synchronization frames are located outside permitted limits (jitter)

System events in STEP 7 (TIA Portal)

The maintenance information is generated in STEP 7 with the following system events:

- Maintenance demanded - indicated for each port by a yellow wrench icon  in the device view or in the hardware configuration.

You can find more information in the STEP 7 online help.

5.3.3 Channel diagnostics

Function

Channel-related diagnostics provides information about channel faults in modules.

Channel faults are mapped as channel diagnostics data in IO diagnostics data records.

The data record is read using the instruction "RDREC".

Structure of the diagnostics data records

The data records supported by the ET 200SP distributed I/O system are based on the standard PROFINET IO - Application Layer Service Definition V2.3.

You can purchase the standard from the PROFIBUS User Organization on the Internet (<http://www.profibus.com>).

Coding of the extended channel diagnostics (as of firmware version V3.3.0)

With the IM 155-6 PN ST interface module, the following extended channel diagnostics are reported:

Slot number	ChannelError-Type (CET)	ExtendedChannel-ErrorType (ECET)	Associated value AddValue	Diagnostics
Module slot	0x0602	0x0691	Slot	Station stop - module parameter "Potential group" faulty or incorrect BaseUnit in actual slot (AddValue)
Slot 0	0x0602	0x0693	0x00	Diagnostics with missing server module
	0x0602	0x0698	0x00	Diagnostics backplane bus too long
	0x0602	0x0699	Slot	Diagnostics with incorrect bus configuration
	0x0602	0x069C	0x00	Diagnostics with incorrectly plugged BusAdapter
Server module slot	0x0610	0x06B0	0x00	Group diagnostics: Missing supply voltage L+ for the potential groups Note: The slot in which the light-colored BaseUnit of the respective load module is located is coded in the "ChannelNumber" element.

Structure of the manufacturer-specific diagnostics data records (firmware version < V3.3.0)

The structure of the diagnostics data records is differentiated by the BlockVersion. The following BlockVersion applies to the IM 155-6 PN ST interface modules:

Table 5- 8 Structure of the manufacturer-specific diagnostics data records

IM 155-6 PN ST interface module	BlockVersion
6ES7155-6AU00-0BN0	W#16#0101

Manufacturer-specific diagnostics in the User Structure Identifier (USI)

The following manufacturer-specific diagnostics are signaled in the USI with the IM 155-6 PN ST interface module:

Table 5- 9 Manufacturer-specific diagnostics in the USI

USI no. W#16#...	Diagnostics
0003	Group diagnostics: Missing supply voltage L+ for the potential groups *
0004	Diagnostics with missing server module
0005	Diagnostics when more than one I/O module has been pulled
0006	Diagnostics with incorrect BaseUnit
0007	Diagnostics with incorrect bus configuration

* As of IM 155-6 PN ST V1.1.x and GSD file 04/2013, this diagnostics is only signaled if the "Group diagnostics: Missing supply voltage L+" parameter has been activated.

USI structure = W#16#0003

Table 5- 10 USI structure = W#16#0003

Data block name	Content	Comment	Bytes
USI	W#16#0003	Manufacturer-specific diagnostics with failure of supply voltage L+ as of slot x	2
Followed by the slot as of which the supply voltage L+ has failed.			
Slot	W#16#0001 to W#16#0020	Bit 8 to 15	1
		Bit 0 to 7	1
Followed by 2 reserved bytes:			
	Reserved		1
	Reserved		1

USI structure = W#16#0004

Table 5- 11 USI structure = W#16#0004

Data block name	Content	Comment	Bytes
USI	W#16#0004	Manufacturer-specific diagnostics with missing server module Result: Station stop <ul style="list-style-type: none"> The I/O modules fail → substitute value behavior The interface module continues to exchange data with the IO controller. 	2
Followed by 4 reserved bytes:			
	Reserved		1
	Reserved		1
	Reserved		1
	Reserved		1

USI structure = W#16#0005

Table 5- 12 USI structure = W#16#0005

Data block name	Content	Comment	Bytes
USI	W#16#0005	Manufacturer-specific diagnostics if more than one I/O module has been pulled. The number of pulled I/O modules is displayed. Result: Station stop <ul style="list-style-type: none"> The I/O modules fail → substitute value behavior The interface module continues to exchange data with the IO controller. 	2
The number of pulled I/O modules follows			
Quantity	W#16#0002 to W#16#0020	Bit 8 to 15	1
		Bit 0 to 7	1

5.3 Alarms

Data block name	Content	Comment	Bytes
Followed by 2 reserved bytes:			
	Reserved		1
	Reserved		1

USI structure = W#16#0006

Table 5- 13 USI structure = W#16#0006

Data block name	Content	Comment	Bytes	
USI	W#16#0006	Manufacturer-specific diagnostics if an I/O module is installed on an incorrect BaseUnit. Result: Station stop <ul style="list-style-type: none"> The I/O modules fail → substitute value behavior The interface module continues to exchange data with the IO controller. 	2	
Followed by the slot for the I/O module:				
	Slot	W#16#0001 to W#16#0020	Bit 8 to 15	1
			Bit 0 to 7	1
Followed by 2 reserved bytes:				
	Reserved		1	
	Reserved		1	

USI structure = W#16#0007

Table 5- 14 USI structure = W#16#0007

Data block name	Content	Comment	Bytes	
USI	W#16#0007	Manufacturer-specific diagnostics if operation is not possible with existing bus configuration Result: Station stop <ul style="list-style-type: none"> The I/O modules fail → substitute value behavior The interface module continues to exchange data with the IO controller 	2	
Followed by the slot for the I/O module:				
	Slot	W#16#0001 to W#16#0040	Bit 8 to 15	1
			Bit 0 to 7	1
If slot 0 is specified, check the width of the station configuration (maximum 1 m).				
Followed by 2 reserved bytes:				
	Reserved		1	
	Reserved		1	

5.3.4 Invalid configuration states of the ET 200SP on PROFINET IO

Invalid configuration states

The following invalid configuration states of the ET 200SP distributed I/O system lead to the failure of the IO device or prevent the exchange of user data with the I/O modules.

- Number of modules exceeds maximum configuration
- Faulty backplane bus (e.g. defective BaseUnit). ET 200SP backplane bus interruptions do not trigger an interrupt.
- At least one I/O module is installed in a different BaseUnit than the one configured in the parameters.
- Missing server module
- Invalid or incorrectly configured BusAdapter

Note

If you drag more than one I/O module or the server module the node will stop. All I/O modules of the ET 200SP distributed I/O system fail (substitute value behavior) but the interface module is still exchanging data.

Revoking the station stop (by correcting the invalid configuration state) leads to a brief failure of the ET 200SP distributed I/O system and automatic restart.

See also

Status and error displays (Page 26)

Channel diagnostics (Page 33)

5.3.5 Failure of supply voltage L+ at BaseUnit BU...D

Failure of the supply voltage L+

The I/O modules react as follows to failure of the supply voltage L+ on the BaseUnit BU...D:

- If an I/O module is removed during failure of the supply voltage, a pull alarm is generated.
- If an I/O module is installed during failure of the supply voltage, an insert alarm is generated.

5.3.6 STOP of the IO controller and recovery of the IO device

STOP of the SIMATIC IO controller

Diagnostics frames received from the IO device while the IO controller is in STOP do not initiate a call of any corresponding OBs when the IO controller goes into RUN. You must read the data record E00CH with the "RDREC" instruction in OB 100. This record contains all diagnostics for the slots assigned to an IO controller in an IO device.

Recovery of the SIMATIC IO devices

If you want to read the diagnostics of a station after its return, you have to read the E00CH data record with the "RDREC" instruction in OB 86. This record contains all diagnostics for the slots assigned to an IO controller in an IO device.

Compatibility

Compatibility between the versions of the IM 155-6 PN ST

The table below describes which version you can use in the configuration for which actually plugged version of the IM 155-6 PN ST interface module. The table also describes the functional differences of the versions of the IM 155-6 PN ST interface module.

IM 155-6 PN ST configured	IM 155-6 PN ST plugged					Changes compared to previous version
	V1.0.x	V1.1.x	V3.1.x	V3.3.x	V4.1.x	
V1.0	✓	✓	✓	✓	✓	---
V1.1	---	✓	✓	✓	✓	<ul style="list-style-type: none"> The "Group diagnostics: Missing supply voltage L+" parameter can be set on the server module "Status of supply voltage L+ of the I/O modules" can be configured on the server module
V3.1	---	---	✓	✓	✓	<ul style="list-style-type: none"> User data 512 bytes Station extension via ET-Connection
V3.3	---	---	---	✓	✓	<ul style="list-style-type: none"> Support of submodules
V4.1	---	---	---	---	✓	---

Note

IM 155-6 PN ST (6ES7155-6AU00-0BN0) with firmware version V4.1

You can upgrade the previous version of the IM 155-6 PN ST interface module (6ES7155-6AU00-0BN0) to the firmware version V4.1. In this case configure the module as IM 155-6 PN ST interface module (6ES7155-6AU01-0BN0) with firmware version V4.1.

Status of the supply voltage

Load voltage diagnostics are only valid if the station started up with a valid and complete configuration.

- For modules in the following table without a parameter assignment, the status of the supply voltage is always signaled as "1" regardless of the actual status of the supply voltage.
- If a potential group is exclusively made up of modules without parameter assignment from the table below, no group diagnostics "Missing supply voltage L+" is signaled for this potential group.

Modules	Article number
DI 8x24VDC ST	6ES7131-6BF00-0BA0
DI 16x24VDC ST	6ES7131-6BH00-0BA0
DI 8x24VDC HF	6ES7131-6BF00-0CA0
DQ 4x24VDC/2A ST	6ES7132-6BD20-0BA0
DQ 8x24VDC/0,5A ST	6ES7132-6BF00-0BA0
DQ 16x24VDC/0,5A ST	6ES7132-6BH00-0BA0
DQ 8x24VDC/0,5A HF	6ES7132-6BF00-0CA0

Reaction times for fail-safe modules

The following maximum reaction time of the interface module must be taken into account when calculating the reaction times of fail-safe modules:

maximum reaction time = configured update time + 400 µs (but at least 1.4 ms)

Technical specifications

Technical specifications of the IM 155-6 PN ST

Article number	6ES7155-6AU01-0BNO
General information	
Product type designation	IM 155-6 PN ST
HW functional status	From FS03
Product function	
<ul style="list-style-type: none"> I&M data 	Yes; I&M0 to I&M3
<ul style="list-style-type: none"> Module swapping during operation (hot swapping) 	Yes; Single hot swapping
<ul style="list-style-type: none"> Isochronous mode 	No
Engineering with	
<ul style="list-style-type: none"> STEP 7 TIA Portal configurable/integrated from version 	V14
<ul style="list-style-type: none"> STEP 7 configurable/integrated from version 	V5.5 SP4 and higher
<ul style="list-style-type: none"> PROFINET from GSD version/GSD revision 	V2.3 / -
Configuration control	
via dataset	Yes
Supply voltage	
Rated value (DC)	24 V
permissible range, lower limit (DC)	19.2 V
permissible range, upper limit (DC)	28.8 V
Reverse polarity protection	Yes
Short-circuit protection	Yes
Mains buffering	
<ul style="list-style-type: none"> Mains/voltage failure stored energy time 	10 ms
Input current	
Current consumption (rated value)	450 mA
Current consumption, max.	550 mA
Inrush current, max.	3.7 A
I^2t	0.09 A ² ·s
Power	
Infeed power to the backplane bus	4.5 W
Power loss	
Power loss, typ.	1.9 W
Address area	
Address space per module	

Article number	6ES7155-6AU01-0BN0
<ul style="list-style-type: none"> Address space per module, max. 	256 byte; per input / output
Address space per station	
<ul style="list-style-type: none"> Address space per station, max. 	512 byte; Dependent on configuration
Hardware configuration	
Rack	
<ul style="list-style-type: none"> Quantity of operable ET 200SP modules, max. 	32
<ul style="list-style-type: none"> Quantity of operable ET 200AL modules, max. 	16
Submodules	
<ul style="list-style-type: none"> Number of submodules per station, max. 	256
Interfaces	
Number of PROFINET interfaces	1; 2 ports (switch)
1. Interface	
Interface types	
<ul style="list-style-type: none"> Number of ports 	2
<ul style="list-style-type: none"> integrated switch 	Yes
<ul style="list-style-type: none"> BusAdapter (PROFINET) 	Yes; compatible BusAdapters: BA 2x RJ45, BA 2x FC, BA 2x M12
Protocols	
<ul style="list-style-type: none"> PROFINET IO Device 	Yes
<ul style="list-style-type: none"> Open IE communication 	Yes
<ul style="list-style-type: none"> Media redundancy 	Yes; PROFINET MRP
Interface types	
RJ 45 (Ethernet)	
<ul style="list-style-type: none"> Transmission procedure 	PROFINET with 100 Mbit/s full duplex (100BASE-TX)
<ul style="list-style-type: none"> 10 Mbps 	Yes; for Ethernet services
<ul style="list-style-type: none"> 100 Mbps 	Yes; PROFINET with 100 Mbit/s full duplex (100BASE-TX)
<ul style="list-style-type: none"> Autonegotiation 	Yes
<ul style="list-style-type: none"> Autocrossing 	Yes
Protocols	
PROFINET IO Device Services	
<ul style="list-style-type: none"> IRT 	Yes; with send cycles of between 250 µs and 4 ms in increments of 125 µs
<ul style="list-style-type: none"> PROFInergy 	Yes
<ul style="list-style-type: none"> Prioritized startup 	Yes
<ul style="list-style-type: none"> Shared device 	Yes
<ul style="list-style-type: none"> Number of IO Controllers with shared device, max. 	2

Article number	6ES7155-6AU01-0BNO
Redundancy mode	
<ul style="list-style-type: none"> • PROFINET system redundancy (S2) 	No
Media redundancy	
<ul style="list-style-type: none"> – MRP 	Yes
<ul style="list-style-type: none"> – MRPD 	No
Open IE communication	
<ul style="list-style-type: none"> • TCP/IP 	Yes
<ul style="list-style-type: none"> • SNMP 	Yes
<ul style="list-style-type: none"> • LLDP 	Yes
Interrupts/diagnostics/status information	
Status indicator	Yes
Alarms	Yes
Diagnostics function	Yes
Diagnostics indication LED	
<ul style="list-style-type: none"> • RUN LED 	Yes; green LED
<ul style="list-style-type: none"> • ERROR LED 	Yes; red LED
<ul style="list-style-type: none"> • MAINT LED 	Yes; Yellow LED
<ul style="list-style-type: none"> • Monitoring of the supply voltage (PWR-LED) 	Yes; green PWR LED
<ul style="list-style-type: none"> • Connection display LINK TX/RX 	Yes; 2x green link LEDs on BusAdapter
Potential separation	
between backplane bus and electronics	No
between PROFINET and all other circuits	Yes; 1 500 V AC
between supply and all other circuits	No
Permissible potential difference	
between different circuits	Safety extra low voltage SELV
Isolation	
Isolation tested with	707 V DC (type test)
Standards, approvals, certificates	
Network loading class	2
Security level	According to Security Level 1 Test Cases V1.1.1
Ambient conditions	
Ambient temperature during operation	
<ul style="list-style-type: none"> • horizontal installation, min. 	0 °C
<ul style="list-style-type: none"> • horizontal installation, max. 	60 °C
<ul style="list-style-type: none"> • vertical installation, min. 	0 °C
<ul style="list-style-type: none"> • vertical installation, max. 	50 °C
Altitude during operation relating to sea level	
<ul style="list-style-type: none"> • Installation altitude above sea level, max. 	5 000 m
Connection method	
ET-Connection	
<ul style="list-style-type: none"> • via BU/BA Send 	Yes; + 16 ET 200AL modules

Article number	6ES7155-6AU01-0BN0
Dimensions	
Width	50 mm
Height	117 mm
Depth	74 mm
Weights	
Weight, approx.	147 g; without BusAdapter

Dimension drawing

A

This appendix contains a dimension drawing of the module installed on a mounting rail. Always observe the specified dimensions for installation in cabinets, control rooms, etc.

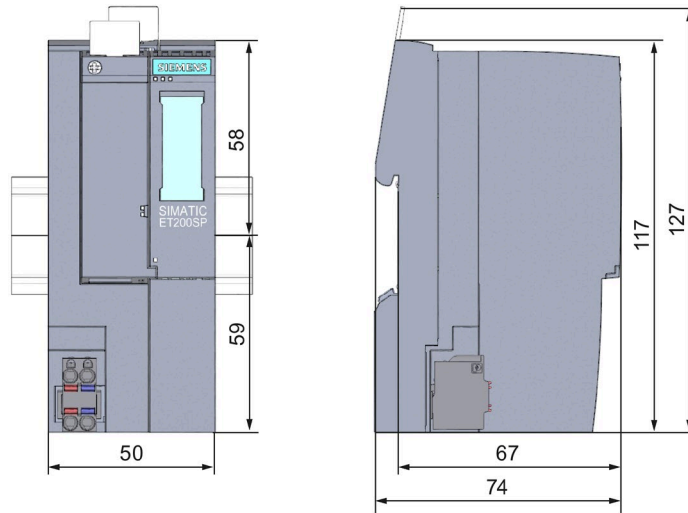

Figure A-1 Dimension drawing of the IM 155-6 PN ST interface module (front and side view)